

# Deriving In-Use PHEV Fuel Economy Predictions from Standardized Test Cycle Results

IEEE Vehicle Power and Propulsion  
Conference

Jeff Gonder  
Aaron Brooker  
Richard Barney Carlson  
John Smart

September 2009

This is a preprint of a paper intended for publication in a journal or proceedings. Since changes may be made before publication, this preprint should not be cited or reproduced without permission of the author. This document was prepared as an account of work sponsored by an agency of the United States Government. Neither the United States Government nor any agency thereof, or any of their employees, makes any warranty, expressed or implied, or assumes any legal liability or responsibility for any third party's use, or the results of such use, of any information, apparatus, product or process disclosed in this report, or represents that its use by such third party would not infringe privately owned rights. The views expressed in this paper are not necessarily those of the United States Government or the sponsoring agency.

The INL is a  
U.S. Department of Energy  
National Laboratory  
operated by  
Battelle Energy Alliance



# Deriving In-Use PHEV Fuel Economy Predictions from Standardized Test Cycle Results

Jeff Gonder and Aaron Brooker

Center for Transportation Technologies and Systems  
National Renewable Energy Laboratory (NREL)  
Golden, CO; USA  
[Jeff.Gonder@nrel.gov](mailto:Jeff.Gonder@nrel.gov); [Aaron.Brooker@nrel.gov](mailto:Aaron.Brooker@nrel.gov)

Richard Barney Carlson\* and John Smart

Advanced Vehicle Test Activity  
Idaho National Laboratory (INL)  
Idaho Falls, ID; USA

[Richard.Carlson@inl.gov](mailto:Richard.Carlson@inl.gov); [John.Smart@inl.gov](mailto:John.Smart@inl.gov)

\* Formerly with Argonne National Laboratory (ANL)

**Abstract**—Plug-in hybrid electric vehicles (PHEVs) have potential to reduce or eliminate the United States’ dependence on foreign oil. Quantifying the amount of petroleum each uses, however, is challenging. To estimate in-use fuel economy for conventional vehicles, the U.S. Environmental Protection Agency (EPA) conducts chassis dynamometer tests on standard historic drive cycles and then adjusts the resulting “raw” fuel economy measurements downward. Various publications, such as the forthcoming update to the SAE J1711 recommended practice for PHEV fuel economy testing, address the challenges of applying standard test procedures to PHEVs. This paper explores the issue of how to apply an adjustment method to such raw PHEV dynamometer test results in order to more closely estimate the in-use fuel and electricity consumption characteristics of these vehicles. The paper discusses two possible adjustment methods, and evaluates one method by applying it to dynamometer data and comparing the result to in-use fleet data (on an aftermarket conversion PHEV). The paper also presents the methodologies used to collect the data needed for this comparison. The predictions using the proposed method are shown to provide close agreement with the in-use observations when the actual fleet charging characteristics are included.

**Keywords**—Plug-in hybrid electric vehicles (PHEVs); vehicle testing; in-use; real-world; fuel economy; adjustment procedures

## I. INTRODUCTION

Plug-in hybrid electric vehicles, or PHEVs, hold promise for reducing U.S. dependence on oil for transportation. They can be externally charged to directly displace petroleum during short trips while operating in a charge-depleting (CD) mode. After depleting the externally charged energy, PHEVs still achieve high fuel economy similar to that of hybrid electric vehicles (HEVs) through regenerative energy recovery during braking, turning the engine off instead of idling, and enabling higher engine efficiency. This operation is referred to as the charge-sustaining (CS) mode. The combination of these two modes provides a large portion of the benefits of a pure electric vehicle (EV) without the range limits, significant additional battery weight, and high battery costs.

The dual operating modes that make PHEVs attractive also make it difficult to estimate their in-use fuel economy. Conventional vehicles have a single mode of operation, so test procedures for these vehicles capture only one mode. PHEVs, on the other hand, deliver vastly different fuel economy

between CD and CS mode, so PHEV test procedures need to capture and appropriately combine both modes together [1,2]. To perform this CD vs. CS mode weighting, PHEV test procedures rely on a utility factor (UF) curve [3]. Based on the distance at which the PHEV transitions from CD to CS operation, the UF curve provides the utility of the vehicle’s CD consumption behavior relative to the CS consumption. Equation (1) expresses this mathematically, where C represents the PHEV consumption characteristics in the designated operating mode, and the UF is calculated as a function of the depletion distance, D.

$$C_{\text{Total}} = C_{\text{CD}} * \text{UF}(D) + C_{\text{CS}} * (1 - \text{UF}(D)) \quad (1)$$

The UF for a vehicle with zero depletion distance capability (i.e., a regular HEV) is zero, which makes the total consumption in (1) simply equal to the CS result. The UF for a vehicle with near limitless depletion capability (i.e., a long-range EV) is one, which makes the total consumption in (1) simply equal to the CD result. For all depletion distances in between, the UF derives from data in the 2001 National Household Travel Survey (NHTS), which provides a representative distribution of the distance U.S. vehicles travel daily [4]. Assuming that PHEVs recharge on average once per day, the national daily driving distance distribution indicates the CD utility based on the depletion distance measured over a given standard test cycle.

Historically, the EPA has used the city test (comprised of the Urban Dynamometer Driving Schedule, or UDDS) and the Highway Fuel Economy Test (HFET) to objectively measure vehicle fuel economy. These cycles alone do not capture several real-world operating characteristics, such as higher actual driving aggressiveness and driving in cold and hot temperatures, and so their raw results tend to over-estimate in-use fuel economy. In order to improve in-use fuel economy predictions, the EPA began using a “5-cycle test procedure” in 2008, which applies different weightings to the fuel use measurements from different portions of the UDDS, HFET, and three additional drive cycles [5]. Such an approach would be difficult to implement for PHEVs, since repeating all five cycles multiple times for CD as well as CS testing would require significant effort. It also does not seem possible to extract the CD fuel and electricity consumption characteristics

for different fractions of cycles out of the CD testing (which uses full and not fractional cycle repetitions).

The EPA has defined a shortcut “MPG-based approach” to approximate the 5-cycle procedure by simply applying adjustments to UDDS and HFET test results. Equations (2) and (3) provide the EPA equations for estimating real world fuel economy (FE) in miles per gallon (MPG) from the two historic test cycle results. Note that the city test equation actually references the Federal Test Procedure (FTP) fuel economy, which consists of one cold start and one hot start UDDS. For simplicity and because of the availability of hot start UDDS and not full FTP test results, the remainder of this paper will use UDDS fuel economy in place of the FTP value (which would be expected to be slightly lower due to the cold start). The shortcut MPG-based adjustments can be similarly applied to raw PHEV UDDS and HFET test results, but the vehicles’ two different operating modes again complicate matters.

$$\text{City MPG} = \frac{1}{\left(0.003259 + \frac{1.1805}{\text{FTP FE}}\right)} \quad (2)$$

$$\text{Highway MPG} = \frac{1}{\left(0.001376 + \frac{1.3466}{\text{HFET FE}}\right)} \quad (3)$$

Fig. 1 shows possible PHEV performance changes in response to increased driving demands (which the adjustment equations are intended to represent). The solid line indicates raw test results, and the blue (darker) lines represent battery state of charge (SOC). During CD operation the blue line slopes downward, and during CS operation (shown on the right side of the same figure), the SOC remains relatively flat. The dashed blue line shows an adjustment option representing an increase in electric power that depletes the battery sooner. Similarly, the orange (lighter) gasoline consumption line can be adjusted left to represent a decrease in CD distance and/or up to represent an increase in fuel consumption. Should the adjustments be made to the electrical energy use, gasoline energy use, or both? The next section will explore these considerations in more detail.

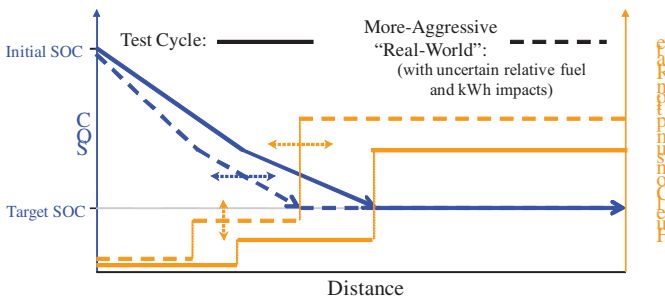

Figure 1. Added power demands can impact PHEV state-of-charge (SOC) depletion rate, distance to reach charge-sustaining operation, and fuel consumption rate.

## II. POTENTIAL ADJUSTMENT APPROACHES

Adjusting raw PHEV dynamometer test results to generate in-use consumption estimates requires making assumptions about changes to fuel and electricity consumption. Figs. 2 and 3 illustrate the assumptions included in two different approaches. The All-Electric Method in Fig. 2 assumes that all additional vehicle power requirements are handled by the electric drive in CD mode and simply result in a higher rate of electric consumption and a shorter CD distance. In CS mode, the gasoline consumption increases the same way that it would for a conventional hybrid vehicle. The disadvantages to this method include: 1) The present MPG-based adjustment equations use units of gasoline fuel, not electricity consumption. More specifically, the approach approximates the additional fuel into the engine required to satisfy the additional energy output. The electric pathway is more efficient, so it may require a smaller adjustment of energy into the motor to achieve the same increase in energy out. 2) The faster electric depletion may be unachievable by vehicle designs with relatively low battery/motor power. Such vehicles will increase the gasoline consumption rather than the electric consumption.

The Blended Method as illustrated in Fig. 3 offers an alternative. It assumes that the increase in gasoline use during CD mode is the same as the increase calculated for CS mode. This works well for blended PHEVs that have lower electric power capabilities for CD mode, and would thus require additional engine power (blended with the electrical power output) for more aggressive driving. The downside of this method is that PHEVs with high electric power capabilities may not need help from the engine and therefore would not use more gasoline in CD mode but would simply deplete their battery energy over a shorter distance. It is also possible that a blended PHEV would actually increase its depletion distance in the event that the vehicle controller commanded the added engine output in CD mode to be high power (to achieve high engine efficiency) and thus prolonged its battery depletion.

Even so, such tradeoffs between CD fuel consumption and depletion distance should somewhat balance out through UF application. For instance, though this Blended Method for applying adjustments may penalize the high electric power PHEV with some excess CD fuel use, the method assumes a longer CD distance than the vehicle actually achieves. This gives it an inflated UF weighting for CD fuel displacement (relative to its CS fuel use). These two factors may roughly balance each other out when calculating the total combined consumption. A similar balance (in the reverse direction) could work out for the longer depletion distance blended PHEV.

The remainder of this paper will test the proposed Blended Method for applying adjustment equations by assessing its ability to adjust raw dynamometer test results on an actual PHEV in order to estimate the vehicle’s in-use fuel and electricity consumption.

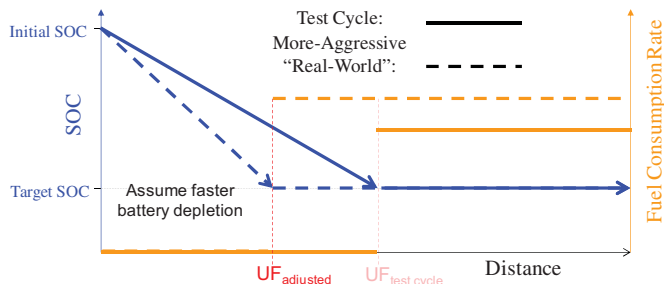

Figure 2. All-Electric Method for applying adjustment equations.

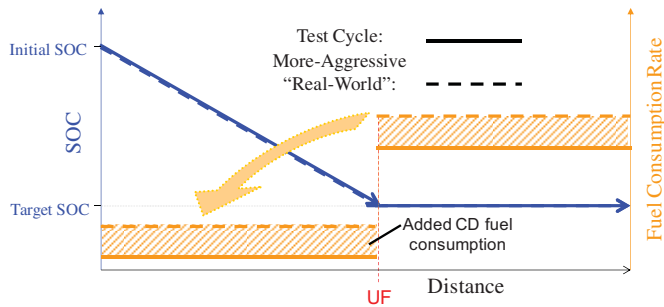

Figure 3. Blended Method for applying adjustment equations.

### III. DATA AVAILABLE FOR METHOD EVALUATION

#### A. PHEV Conversion Dynamometer Testing

The Hymotion Prius PHEV conversion is a production PHEV that is based on the second generation Toyota Prius (see Fig. 4). A supplemental 5 kWh battery system, composed of A123 Li-ion cells, is added into the rear luggage compartment of the Prius to provide additional electrical energy to the powertrain while driving. This Hymotion battery system is connected in parallel with the production Prius NiMH battery through a 10 kW DC to DC converter. An on-board charger is used to recharge the Hymotion battery system from the electric grid while the vehicle is parked. Overall, the additional energy from the Hymotion battery system displaces petroleum consumption with electrical energy consumption, resulting in higher fuel economy. As mentioned previously, the standardized test cycles used for dynamometer testing include the UDDS (urban) and HFET (highway) drive cycles. These two drive cycles were included in the testing program to determine a baseline for comparison with on-road testing of the Hymotion Prius PHEV conversion. The dynamometer testing was conducted at Argonne National Laboratory’s (ANL’s) Advanced Powertrain Research Facility (APRF).

The Hymotion battery system adds approximately 85 kg (187 lbs) to the mass of the Prius. This, along with increased rolling resistance, is taken into account for the dynamometer testing by the road load settings of the dynamometer. Table I shows the dynamometer road load coefficients used for this testing. Results from the dynamometer testing, shown in Table II, demonstrate the effectiveness of the Hymotion PHEV system in significantly reducing fuel consumption during CD as compared with CS operation. This reduction is achieved by decreasing engine on time (more all-electric operation) and by

greater utilization of the electric drive system to reduce the engine’s power output even when it is operating.



Figure 4. Hymotion Prius PHEV during chassis dynamometer testing.

TABLE I. HYMOTION PRIUS DYNAMOMETER TEST COEFFICIENTS

A [kg & (lbs)]	B [kg/kph & (lbs/mph)]	C [kg/kph <sup>2</sup> & (lbs/mph <sup>2</sup> )]	Test Weight [kg & (lbs)]
9.48 (20.9)	0.039 (0.139)	0.003 (0.016)	1547 (3410)

TABLE II. HYMOTION PRIUS RAW PHEV TEST RESULTS

Drive Cycle	Fuel Consumption [L/100 km] & (Fuel Economy [mpg])	AC Electrical Consumption [kWh/100 km & (Wh/mi)]
CD UDDS	1.6 (144)	11.2 (181)
CD HFET	2.4 (98)	8.2 (132)
CS UDDS	3.6 (65)	0 (0)
CS HFET	3.7 (63)	0 (0)

#### B. In-Use Fleet Evaluation of PHEV Conversions

The U.S. Department of Energy’s (DOE’s) Advanced Vehicle Testing Activity (AVTA), a part of DOE’s Vehicle Technologies Program, performs independent testing of advanced technology vehicles to determine their energy efficiency and petroleum consumption reduction potential. AVTA is conducting a comprehensive PHEV evaluation program, including the aforementioned dynamometer testing as well as testing in track and on-road environments. The Idaho National Laboratory conducts on-road testing and fleet demonstrations for AVTA.

AVTA monitors PHEV in-use performance through its fleet demonstration program. In this program, AVTA has collected in-use data from 12 different PHEV conversion models in a fleet of 186 vehicles operated in 23 U.S. states and Canada by over 75 organizations. Over 900,000 km (550,000 mi) have been logged since the program’s onset in late 2007. Vehicles are driven by fleet participants to perform a variety of missions. The majority of vehicles are operated in commercial fleets. Approximately 10% of the driving to date has been logged in vehicles used for private use [6].



The vehicles are equipped with onboard controller area network (CAN) data loggers. These loggers capture time history data to monitor gasoline and electricity consumption and numerous other vehicle, charging, and environmental parameters. AVTA uses automated database routines to analyze these data to quantify energy consumption and characterize driving and charging behavior.

For comparison to dynamometer test results in this paper, a subset of the continuously collected AVTA fleet data was chosen. Data for comparison come from 87 Hymotion Priuses with the V2Green data logger; the vehicles were driven between April 1, 2008 and March 31, 2009. Table III shows basic trip statistics for this fleet subset, including the distribution of driving in CD and CS modes. Table IV shows the fleet subset overall average gasoline fuel economy and electricity consumption by operating mode.

Energy consumption varies widely over time as driving and charging patterns and environmental conditions vary. Fig. 5 shows the distribution of AVTA fleet monthly vehicle fuel use for vehicle months when more than 322 km (200 mi) were driven. The figure illustrates the potential for the Hymotion Prius PHEV conversion to achieve extremely low fuel consumption over sustained distances, but also the wide range of fuel consumption in real-world conditions. Reasons for this distribution include variations in charging frequency and duration, driving speed and aggressiveness, accessory usage, and ambient temperature [7].

TABLE III. HYMOTION PRIUS FLEET DRIVING STATISTICS

Number of vehicles	87
Number of trips	30,540
Total distance driven (km)	482,598
Distance driven in CD mode (km)	174,374
Percent of total distance	36%
Distance driven in CS mode (km)	308,224
Percent of total distance	64%

TABLE IV. FLEET CONSUMPTION BY OPERATING MODE

Operating Mode	Fuel Consumption [L/100 km] & (Fuel Economy [mpg])	AC Electrical Consumption [kWh/100 km & (Wh/mi)]
Overall	4.8 (49)	3.9 (63)
CD	3.9 (61)	10.9 (175)
CS	5.5 (43)	0 (0)

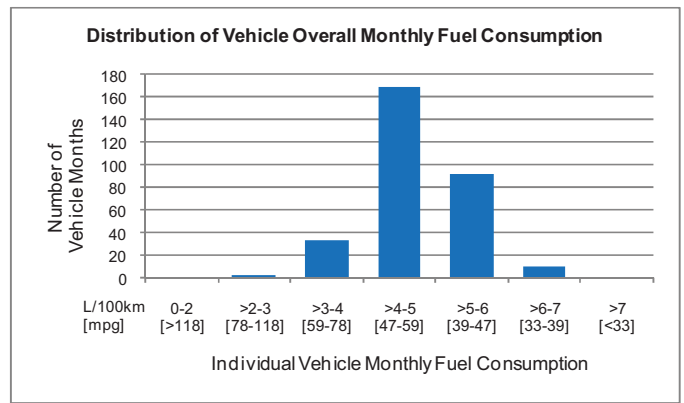

Figure 5. Distribution of fleet performance.

#### IV. RESULTS: COMPARING ADJUSTED DYNAMOMETER RESULTS WITH IN-USE FLEET OBSERVATIONS

The raw CS fuel consumption results in Table II are close to those that the equivalent HEV Prius would obtain over the UDDS and HFET drive cycles. The 5.1 L/100 km (46 mpg) window sticker estimate for the 2008 model year HEV Prius reflects the impact of the aforementioned adjustment equations and agrees exactly with the average fuel consumption reported by over 100 Prius owners [8]. Can adjustments to the dynamometer results for the Hymotion Prius PHEV conversion provide similar agreement with the average fleet testing observations?

Fig. 6 summarizes the steps of the proposed adjustment method and demonstrates its application to the raw dynamometer test results for the Hymotion Prius PHEV conversion. The city MPG-based adjustment equation is first applied to the raw CS UDDS result to obtain the adjusted CS urban fuel consumption (just as would be done for a regular HEV). The resulting fuel consumption increment is then added to each of the four UDDS repetitions that made up this vehicle's CD test to determine the adjusted CD urban consumption. The adjusted CS and CD values are then combined together using the utility factor curve to obtain the adjusted and UF-weighted urban consumption result. The analogous process is then repeated for the raw HFET test results (for which the CD test also spanned four HFET cycle repetitions). Using EPA's historic 55%/45% weighting to combine the adjusted and UF-weighted urban and highway results yields the final composite prediction of 4.2 L/100 km (55 mpg) and 5.5 kWh/100 km (89 Wh/mi).

Note for simplicity that this paper uses lumped application of the single UF curve from the 2001 NHTS data. As an aside, using the city/highway split curves from that data would result in greater spread between the UF-weighted urban and highway results. The final composite predictions vary slightly (1-3% lower for fuel consumption and 5-10% higher for electricity consumption) when using the city/highway split curves and/or fractional UF application [3].

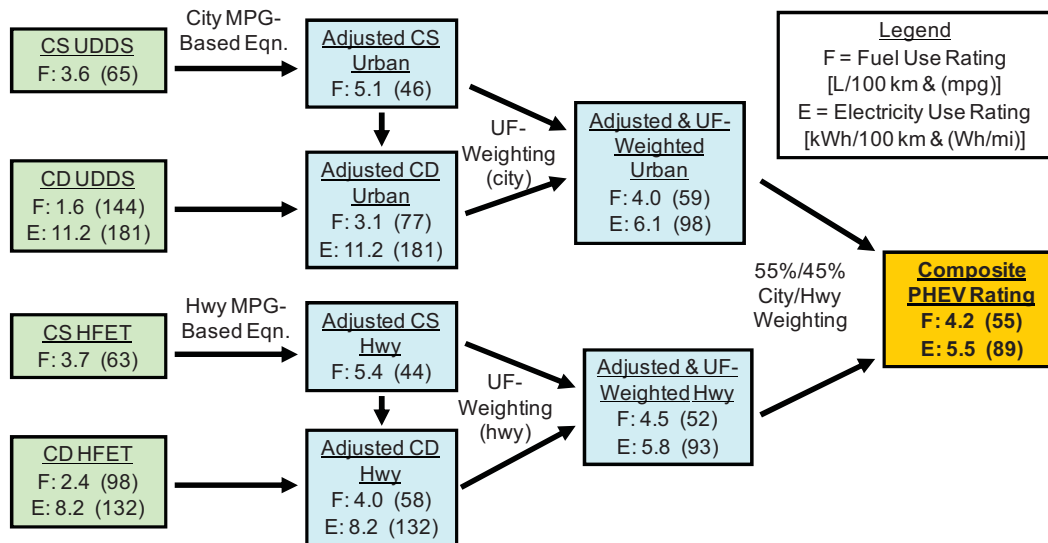

Figure 6. Step-by-step example application of the proposed adjustment method.

Compared to the average fleet results summarized in Table IV, these adjusted dynamometer results represent lower expected fuel consumption and higher electric usage. This could indicate a larger portion of CS operation in the AVTA fleet than is anticipated by the UF curve derived from the 2001 NHTS. Indeed, a comparison of the AVTA fleet distances driven between charging events and the national daily driving distribution from the 2001 NHTS indicates a larger portion of long driving distances (and hence CS operation) in the AVTA data set [9]. Fig. 7 compares the UF as derived from the 2001 NHTS daily distance distribution with that derived from the AVTA data on distance driven between charging events.

Using this fleet-based UF curve instead results in a composite adjusted dynamometer result of 4.5 L/100 km (53 mpg) and 4.3 kWh/100 km (69 Wh/mi), which is closer to the actual fleet results. However, while the known fraction of CD operation in the fleet evaluation is 36%, the fraction predicted by the fleet UF curve (based on the combined CD distance from dynamometer testing) is 44%. This is closer than the 57% CD utility predicted by the 2001 NHTS daily driving distribution, but it is still higher than the known value of 36%. This inconsistency could derive from the fact that the charging events prior to each fleet driving segment may not always bring the PHEV batteries to fully charged, whereas applying the UF implicitly assumes combining fully-charged CD with CS test results. Fixing the UF to a value of 0.36 for combining both city and highway adjusted CS and CD dynamometer results yields a composite prediction of 4.6 L/100 km (51 mpg) and 3.6 kWh/100 km (57 Wh/mi). As mentioned in the introduction, had a full FTP been used for the CS dynamometer test rather than hot start UDDS, the predicted fuel consumption would be slightly higher. In any event, the error bar on the fleet fuel economy measurement has been observed to be less than 5%, and the predicted fuel consumption using the UDDS and HFET test data already falls within this error bar. The predicted electricity consumption falls less than 10% lower than the actual fleet average result. Fig. 8 summarizes the fuel and electricity consumption predicted by the dynamometer data

adjustment approach with different UF weightings, and compares these predictions to the actual in-use fleet averages.

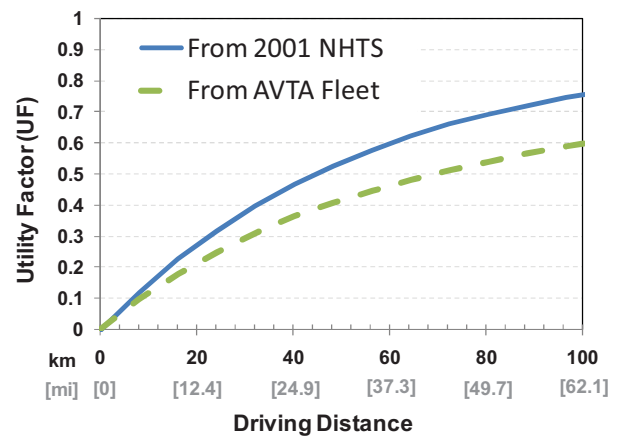

Figure 7. Comparison of UF curves based on the 2001 NHTS daily driving distance vs. the AVTA fleet driving distances between recharging.

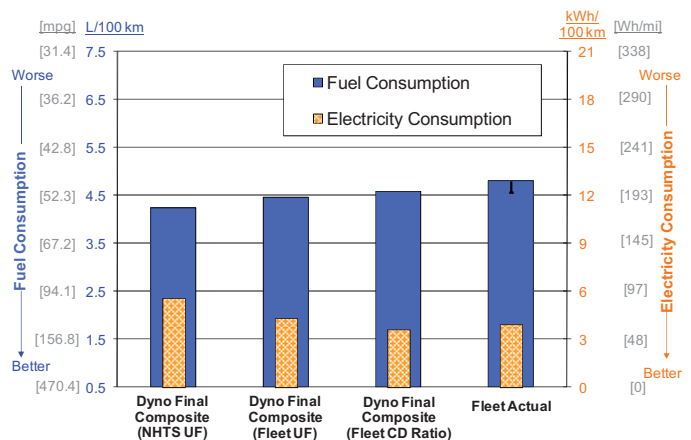

Figure 8. Comparison of adjusted dynamometer results using different UF weightings with the average in-use AVTA fleet consumption.

## V. SUMMARY

The complications surrounding a PHEV's two operating modes make it far from a trivial task to adjust raw dynamometer test results in order to more closely approximate real-world operation. Nevertheless, the significant gap between raw, unadjusted test results and actual in-use observation (for conventional vehicles and HEVs as well as PHEVs) underscores the importance of applying some sort of adjustment. This paper presented two possible adjustment approaches and identified the Blended Method of applying adjustment equations as a promising option for estimating in-use PHEV performance. Applying the method to raw dynamometer test data (and using the actual average fraction of CD vs. CS operation from the fleet data) indeed provided close agreement with the average fleet electricity and fuel consumption.

While this initial comparison is promising, further evaluation of the proposed adjustment method will be required on other vehicles and PHEV platforms. In particular, it will be important to evaluate how well the method predicts in-use performance for non-blended PHEVs that possess high electric power capability. As discussed, the proposed method utilizes a simplifying assumption that the PHEV will deplete its stored battery energy over the same distance in real-world cycles as in the dynamometer tests, which may not be the case in reality [10]. This paper described how the UF application may help offset such differences, but further evaluation will need to confirm how well this works out. Although fleet driving data for PHEVs other than the Hymotion Prius conversion is currently scarce, evaluation on different PHEV platforms could be performed in the near future through vehicle simulation over UDDS, HFET, and a "fleet" of real-world operating profiles [11].

With respect to the proposed method as applied to the Hymotion Prius PHEV conversion, the relatively close match of the prediction to the actual fleet results builds some confidence in the general methodology. Assuming the broader validity of UF-weighting using national driving statistics and a once daily recharge assumption, we turn now to the proposed method's average consumption estimates using the 2001 NHTS UF curve—4.2 L/100 km (55 mpg) and 5.5 kWh/100 km (89 Wh/mi). This represents an average decrease in gasoline fuel consumption of roughly 20% relative to the comparable HEV Prius window sticker value. The average comparison only tells part of the story, though, because PHEVs exhibit an extreme case of "Your Mileage May Vary" (as evidenced by the spread in results on Table II and Fig. 5).

In order to adequately set individual drivers' PHEV performance expectations, both the causes and the magnitudes of variations in fuel and electricity consumption need to be clearly communicated. Demonstrating the positive outcomes of energy-conscious driving and frequent recharging could also go beyond appropriate expectation-setting to encouraging drivers to adopt higher fuel-saving habits. Fig. 9 presents an example summary of such variation in PHEV operation.

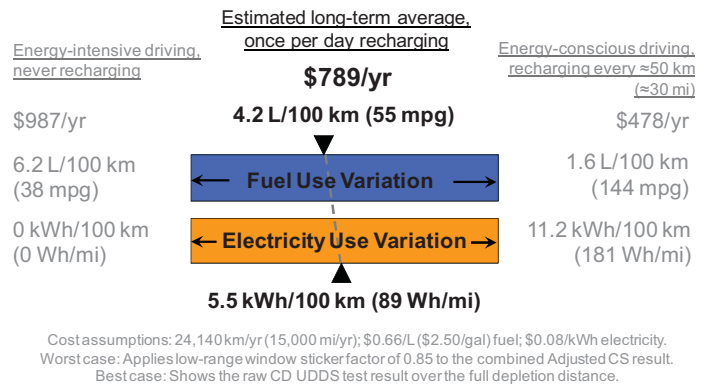

Figure 9. Example representation of the annual energy cost/use for the Hymotion Prius PHEV conversion.

## REFERENCES

- [1] SAE International, Surface Vehicle Recommended Practice SAE J1711—Recommended Practice for Measuring the Exhaust Emissions and Fuel Economy of Hybrid-Electric Vehicles, issued March 1999.
- [2] J. Gonder and A. Simpson, "Measuring and reporting fuel economy of plug-in hybrid electric vehicles," *World Electric Vehicle Association (WEVA) Journal*, vol. 1, May 2007.
- [3] SAE International, Surface Vehicle Information Report SAE J2841—Utility Factor Definitions for Plug-In Hybrid Electric Vehicles Using 2001 U.S. DOT National Household Travel Survey Data, March 2009.
- [4] United States Department of Transportation (U.S. DOT), 2001 National Household Travel Survey (NHTS), [www.bts.gov/programs/national\\_household\\_travel\\_survey/](http://www.bts.gov/programs/national_household_travel_survey/).
- [5] United States Environmental Protection Agency, Fuel Economy Labeling of Motor Vehicles: Revisions to Improve Calculation of Fuel Economy Estimates; Final Rule, 40 CFR Parts 86 and 600, December 27, 2006, <http://www.epa.gov/fedrgstr/EPA-AIR/2006/December/Day-27/a9749.pdf>.
- [6] J. Smart, J. Francfort, D. Karner, M. Kirkpatrick, and S. White, U.S. Department of Energy Advanced Vehicle Testing Activity: Plug-in hybrid electric vehicle testing and demonstration activities, International Electric Vehicle Symposium 24, Stavanger, Norway, 2009.
- [7] H. Iu and J. Smart, Determining PHEV performance potential—User and environmental influences on A123 Systems' Hymotion™ plug-in conversion module for the Toyota Prius, International Electric Vehicle Symposium 24, Stavanger, Norway, 2009.
- [8] Model year 2008 production Prius data from [www.fueleconomy.gov](http://www.fueleconomy.gov), accessed June 29, 2009.
- [9] M. Duoba, R. Carlson, F. Jehlik, J. Smart, and S. White, Correlating dynamometer testing to in-use fleet results of plug-in hybrid electric vehicles, International Electric Vehicle Symposium 24, Stavanger, Norway, 2009.
- [10] R. Carlson, H. Lohse-Busch, M. Duoba, and N. Shidore, Drive Cycle Fuel Consumption Variability of Plug-In Hybrid Electric Vehicles due to Aggressive Driving, SAE Publication No. 2009-01-1335.
- [11] J. Gonder, T. Markel, M. Thornton, and A. Simpson, Using global positioning system travel data to assess real-world energy use of plug-in hybrid electric vehicles, Transportation Research Record (TRR), Journal of the Transportation Research Board (TRB), No. 2017, Dec. 2007.