

Submitted to Physical Review

P. H. Eberhard

XL UCRL-20835
SLAC-PUB-927
Preprint

0.2

RECEIVED
LAWRENCE
RADIATION LABORATORY

JUN 28 1971

LIBRARY AND
DOCUMENTS SECTION

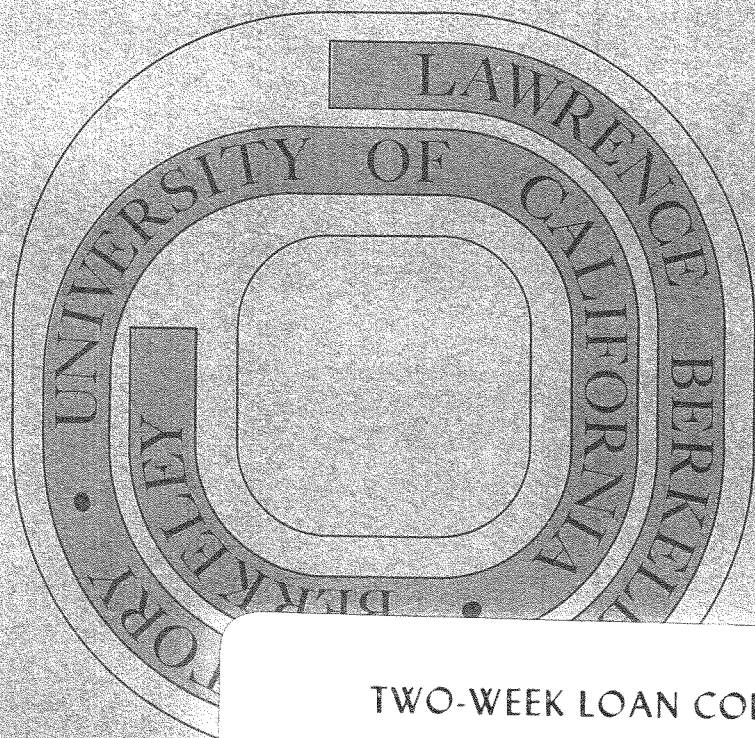

SEARCH FOR MAGNETIC MONOPOLES
IN LUNAR MATERIAL

Philippe H. Eberhard, Ronald R. Ross,
Luis W. Alvarez and Robert D. Watt

June 1971

AEC Contract No. W-7405-eng-48

TWO-WEEK LOAN COPY

This is a Library Circulating Copy
which may be borrowed for two weeks.
For a personal retention copy, call
Tech. Info. Division, Ext. 5545

34

SEARCH FOR MAGNETIC MONOPOLES IN LUNAR MATERIAL*

Philippe H. Eberhard, Ronald R. Ross, and
Luis W. Alvarez

Lawrence Radiation Laboratory
University of California
Berkeley, California 94720

Robert D. Watt

Stanford Linear Accelerator Center
Stanford, California

June 1971

ABSTRACT

A search for magnetic monopoles in lunar material has been performed by the electromagnetic measurement of the magnetic charge of samples. All measurements were found consistent with zero charge for all samples and inconsistent with any other value allowed by the Dirac theory. Upper limits are determined for the monopole flux in cosmic radiation and for the pair-production cross section in proton-nucleon collisions.

I. INTRODUCTION

An electromagnetic monopole detector has been used to measure the magnetic charge of samples of lunar material returned by the Apollo 11 mission. The null result and a preliminary interpretation have been reported.¹ This paper gives a more complete analysis of the experiment.

The discovery of magnetic monopoles would have far-reaching consequences. Their existence has been invoked in the explanation of the phenomenon of electric charge quantization,^{2,3} a phenomenon which has been verified to the limit of experimental accuracy.⁴ According to a recent theory,⁵ the elementary particles would be made of electrically charged monopoles, i. e., particles having both an electric and a magnetic charge.

All searches for monopoles rely on some physical properties attributed to those particles. The failure to discover them in a given experiment calls for careful documentation of the monopole properties that were assumed and for an assessment of their likelihood. A "legalistic" point of view may be appropriate to judge the proofs of absence of monopoles in such an experiment. All the properties assumed in our detection technique stem from long-range interactions, i. e., the only interactions for which reliable predictions can be computed when the coupling constant is as large as the one expected for magnetic monopoles.

In Sec. II we describe the basic properties of the monopole, and in Sec. III we discuss some experimental consequences based on them. In Sec. IV we describe our measurements of the magnetic charge of 28 samples of lunar material. Interpretation of our negative result in terms of limits for the cosmic-ray flux and the production cross

sections depends on the history of the lunar surface, for which reasonable hypotheses are advanced; that history justifies the search for monopoles in the lunar material. These hypotheses cannot be paralleled to the properties assumed for the detection technique. They are described and used to interpret our data in Sec. V, VI, and VII. Some measurements performed on different material with the same equipment and the limit we have obtained for the monopole density in ordinary matter are reported in Sec. VIII. Some remarks about the present experimental situation are given in Secs. IX and X.

II. BASIC PROPERTIES OF MONOPOLES

In classical electrodynamics, a magnetic monopole is a particle that possesses a magnetic charge g , i. e., a source of a flux of magnetic induction \underline{B} ,

$$4\pi g = \oint_S \underline{B} \cdot d\underline{A}, \quad (1)$$

where S is a surface surrounding the monopole and $d\underline{A}$ an element of that surface, and all quantities are measured in Gaussian units. If a monopole is in motion, it generates an electric field \underline{E} around its path in a way similar to that in which an electric charge generates a magnetic field (see Fig. 1),

$$\underline{\nabla} \times \underline{E} = -\frac{1}{c} \frac{\partial \underline{B}}{\partial t} - \frac{4\pi}{c} \underline{j}_m, \quad (2)$$

where \underline{j}_m is the current density of magnetic charges. From Eqs. (1) and (2) one can derive a continuity equation for magnetic current density. Therefore, just as electric charge is conserved, magnetic charge is conserved, so a monopole cannot decay into magnetically neutral particles only. If monopoles exist, there must be at least one kind of them that is stable.

When the general principles of quantum theory are brought into the picture, a study of the scattering of an electron by a magnetically charged particle, even at large distances, shows³ that the magnetic charge must be quantized if the basic principles on which quantum mechanics is founded are to be retained:

$$g = \nu g_0, \quad (3)$$

where ν is an integer and g_0 is the unit of quantization. In the Gaussian system of units

$$g_0 = \frac{e}{2} \frac{\hbar c}{e} = \frac{e}{2} \frac{1}{\alpha}, \quad (4)$$

where $\alpha \approx 1/137$ is the fine-structure constant and e is the electron charge. Therefore, g_0 , in emu, is about 68.5 times the value of e in esu, a condition originally derived by Dirac² and referred to as the Dirac quantization condition.

Other theories^{5,6} have been hypothesized which require that Eq. (3) be valid but that ν in Eq. (3) be a multiple of 2 or 4. References to possible violations of Eq. (3) can be found in the literature,⁷ and searches for such violations have been made.^{8,9} But the demonstration that yields (3) and (4) is the same as the one that quantizes electric charge; therefore, only if monopoles satisfy (3) can they be invoked in the explanation of electric charge quantization we have referred to.

We assume quantization of magnetic charge according to Eqs. (3) and (4) as a basic property of the monopoles we are looking for, except when explicitly mentioned otherwise.

The minimum nonzero magnetic charge is g_0 . Even if a monopole had the minimum charge, its coupling constant to the electromagnetic field would be much stronger than the strong-interaction coupling constant. It follows that computations of short-range interactions will be

at least as unreliable for monopoles as they are for hadrons. However, monopoles have long-range interactions due to the electromagnetic field. For them, the corrections to the $1/r$ Born approximation vary as $1/r^5$ and, for large enough r , should be negligible.¹⁰ For large r the first approximation is reliable, and the properties derived from it are very well established.

III. EXPERIMENTAL CONSEQUENCES

A. Induction in a Coil

Using long-range interactions only, one can deduce the property used in our detection technique. If a monopole travels along the axis of a coil (as in Fig. 2) it will induce an electric field that will contribute to the electromotive force in the coil,¹¹

$$\mathcal{E} = n \frac{4\pi g}{c} \frac{dN}{dt} - \frac{1}{c} \frac{dF}{dt}, \quad (5)$$

where n is the number of turns of the coil and $\frac{dN}{dt}$ is the number of monopoles of charge g passing per unit of time; F is the flux of B the coil.

If the coil is a superconducting coil shorted by a superconducting switch, \mathcal{E} is forced to be zero. The flux F is increased at each pass of the monopole by the value ΔF_1 :¹²

$$\Delta F_1 = n4\pi g. \quad (6)$$

If a sample containing charge g is given a ride of N_p passes along the path of Fig. 2 and the total change, ΔF , is measured, the magnetic charge of the sample can be determined from

$$g = \frac{\Delta F_1}{4\pi n} = \frac{\Delta F}{4\pi n N_p}. \quad (7)$$

B. Binding to Ferromagnetic Crystals

Of course, the above technique detects monopoles that are attached to the sample analyzed, i. e., that are bound to it.

Once a magnetic monopole is in the neighborhood of a ferromagnetic crystal, it will be attracted by its image charge in the crystal. One can show that the binding energy in the ferromagnetic material is greater than ≈ 30 eV by using the classical laws for interaction at distances greater than 1000 \AA . A monopole can escape a magnetic trap formed

of ferromagnetic material only if exposed to a very strong magnetic field.¹³ Of course, it is probable that monopoles would be tightly bound to atoms or to nuclei with a magnetic moment,^{14, 15} but, in ferromagnetic material, the binding is established with more certainty because it depends only on long-range interactions. The presence of ferromagnetic material in a sample would insure trapping of the monopoles that would have been thermalized in it, even if all other binding mechanisms did fail.¹³ That is the case of the lunar sample.¹⁶

C. Energy Loss

Monopoles are bound to lose energy by energy transfer to atoms of the material they traverse. Unless pathological characteristics are attributed to monopoles (like a zero mass, for instance),⁷ they will, because of this energy loss, slow down and be thermalized if there is no magnetic field to accelerate them. However, the rate of energy loss and therefore the range depend on different processes. Some of them, the nuclear interactions for instance, involve short-range interactions and therefore cannot be predicted.

Energy loss by ionization is, however, well understood. When quantum effects are taken into account,¹⁷ one finds that the process involves atoms at distances up to more than 1000 Å from the path of the monopole. Therefore computation of ionization effects may be considered as trustworthy even for large coupling constants. Moreover it can be checked by studying the energy loss of high-Z nuclei. Such computation for monopoles predicts an energy loss rather uniform as a function of energy,¹⁸

$$-\frac{dE}{dx} \approx v^2 10 \text{ GeV cm}^2/\text{g}, \quad (8)$$

where v is the constant appearing in Eq. (3). To take the uncomputable

effects into account, we introduce a new constant N defined by

$$N^2 = \frac{\langle -\frac{dE}{dx} \rangle_{\text{real}}}{10 \text{ GeV cm}^2/\text{g}}. \quad (9)$$

N is defined for a given monopole of a given energy E in such a way that Eq. (9) is satisfied for $\langle -\frac{dE}{dx} \rangle$, the average of the energy loss over the entire range R of the particle. Therefore

$$R(\text{g/cm}^2) = \frac{E(\text{GeV})}{N^2 10}. \quad (10)$$

N is an effective charge, that of a monopole that would have an energy loss by ionization equal to the $\langle -\frac{dE}{dx} \rangle_{\text{real}}$ of the monopole considered. N does not have to be an integer, but the real energy loss must be at least equal to the energy loss by ionization. Therefore

$$N > v. \quad (11)$$

IV. THE MEASUREMENT OF MAGNETIC CHARGE

A. Technique

Our detector has been described elsewhere.¹⁹ It is essentially a superconducting coil shorted by a superconducting switch as shown in Fig. 2. The sample is attached to a cart moving along a closed path that traverses the coil in a tunnel at room temperature, so that the sample need not be cooled below ambient temperature. A superconducting shield protects the coil against induction of current due to changes in the ambient magnetic field.

In order to run the equipment with samples not containing a monopole and still have observable results, a measurable current, i_0 , is stored before the sample is run. This current is generated by feeding a current into an auxiliary coil while the superconducting switch is open, closing the superconducting switch, and then de-energizing the auxiliary coil. Next, the sample is circulated 400 times through the

coil. Finally the switch is opened and the signal resulting from opening the switch is recorded. A magnetically neutral sample gives a standard signal whose amplitude would be exactly the value expected for the current i_0 if it were not for the noise in the electronics. This method of operation provides a test of the apparatus during each measurement even when no monopole is detected.

The magnetic charge of a sample is proportional to the difference between the amplitude of the signal obtained upon opening the switch after running the sample and the standard amplitude. The equipment is calibrated by using a very long solenoid carrying a known flux uniformly along the path of the sample in the coil. The north pole and the south pole of the solenoid protrude out opposite ends of the coil and superconducting shielding in order that the passage of a monopole be properly simulated. The long solenoid is itself calibrated in flux versus current by use of a copper coil of a known number of turns, outside the superconducting shielding.

The current i_0 is equal to the current that a monopole of charge g_0 circulated 1000 times would have produced. Therefore, when circulated 400 times, the minimum charge g_0 would have produced a change of $\pm 40\%$ in the signal recorded on the scope. A bigger charge would have induced an even bigger change.

A study of the noise shows that the standard deviation is roughly equal to the signal produced by a charge g_0 circulated 50 times and was independent of the number of passes N_p actually performed by the sample. When $N_p = 400$ passes, as for most of our measurements, the magnetic charge is measured with an error

$$\delta g = \frac{1}{8} g_0 \quad (12)$$

If, on a measurement, the signal is not consistent with a zero magnetic charge, it is either because the equipment is not functioning correctly or because a nonzero charge has been found. In the latter case, the effect should be found again and again when the measurement is repeated, because the magnetic charge is conserved and because our measurement does not in any way alter the sample analyzed. Whenever g is found not zero by a measurement, the sample is rerun, but just before rerunning, the equipment is tested for malfunctions. In all such cases so far, evidence of malfunction was found.

B. Results

The lunar material analyzed in this experiment was divided into 28 samples of approximately equal weight whose magnetic charges were measured independently. Figure 3 shows the measurement of those charges in a sequence that is approximately chronological. Table I lists the samples by their NASA reference number and by the number as they appear in Fig. 3. Sample 8 was composed of three rocks. Samples 25 and 28 were chips between 1 mm and 1 cm, and samples 22 and 23 were unsieved fines. The remaining samples were sieved fines less than 1 mm from the "Bulk Sample" of material returned, weighing 7.0 kg altogether.

Each of the samples 1 to 11, 13 to 19, and 26 to 28 was run twice, and the value of the magnetic charge reported on Fig. 3 is the average of the two measurements. For the average, the error should be about $0.1 g_0$. During that period, for only one sample (sample 10) did the measured magnetic charge differ from zero by more than 2 standard deviations, but for this sample as well as for all others of this category, the measurement represents still more than 8 standard deviations from $\pm g_0$, the nearest possible value for g .

Sample 12 was run twice, but after the experiment was over, we discovered that the shape of the signal for one of the tests gave clear evidence of switch bouncing; the corresponding measurement ($-0.3 g_0$) was considered unreliable and disregarded. The value corresponding to the other test is plotted in Fig. 3. It is still 7 deviations away from any allowed quantized charge.

When we were running sample 20, and until we ran no. 26, the superconducting switch showed signs of fatigue. The noise on the signal was obviously increased by a factor of about two. To overcome that difficulty, we increased the number of passes from 400 to 800 per run, or performed more than two runs, to make the average more accurate. Later on, we could disregard some of those measurements because we discovered the symptom of switch bouncing in the shapes of their signals. We plotted the average of the remaining measurements on Fig. 3. They are all consistent with a magnetic charge of zero. However, the error is difficult to estimate because the noise did not appear to stay constant and no standard deviation can be given to it reliably. This remark applies to samples 20 to 25 only.

At the time we were running sample 26, a spare switch was adjusted and substituted for the original one. The noise level was again about $1/8$ of g_0 per measurement and constant. For sample 26, Fig. 3 shows only the value of the magnetic charge obtained from the measurement with the good switch.

The measured magnetic charges are all compatible with zero and incompatible with a value $\pm g_0$. If fractional charges were considered as a possibility, then we can state that charges more than $0.3 g_0$ cannot have been present in more than one sample or two.

V. DENSITY OF MONOPOLES IN LUNAR SAMPLE

Once we accept the idea that magnetic charges are all multiples of g_0 , our experiment demonstrates that in all 28 samples, no monopoles were present, or the numbers of north poles and of south poles were equal. We want to use this result to set an upper limit on the total density of monopoles in the lunar sample. We choose to quote the upper limit at 95% confidence, i. e., the density for which the probability of getting our zero-magnetic-charge result is 5%.

If the density of north poles and the density of south poles are not correlated statistically and if the expectation values for both densities are known, the probability that the magnetic charges of N_s equal samples are all zero can be computed. For $N_s \geq 23$, it is less than 5% if the density of north poles and the density of south poles are the same and if the expected sum of both is more than 3.3 for the whole volume explored. Therefore, for the processes that involve statistically independent densities of north and south poles, we state that the expectation value for the density of north and south monopoles in our sample is less than 3.3 with 95% confidence. This number would have been between 3.0 and 3.3 for unequal north and south pole densities and would have been 3.0 if we had not taken into account the possibility of having nonzero equal numbers of south and north poles in the sample.

We consider two main sources of monopoles in the lunar material and treat them separately, since each may have a different density limit due to the different natures of the sources. During all the time the samples have been exposed near the moon's surface at different depths, (a) monopoles of the primary cosmic radiation would have been slowed down and some of them would have ended trapped in the samples, and (b) protons of the cosmic rays could have produced

pairs of monopoles in collisions with nucleons of the lunar sample. For process (a) the densities of north and south poles have obviously been statistically independent. The maximum density due to that source of monopole is obtained by dividing 3.3 by the weight of all samples, 8.3 kg. It is 4×10^{-4} monopoles/g.

For process (b) the creation in pairs causes a potential strong correlation between both densities. However, once the poles of a pair were sufficiently separated, it is unlikely that the mutual attraction between them would have played much of a role, because each of them would rather have been immediately trapped by an atom or a nucleus,^{14, 15} or, in any event, been attracted by its magnetic image in a ferromagnetic crystal¹⁶ closer to it than the other pole is. Each monopole would have been trapped in the grain where it had stopped. If a grain were small, it would have captured only one of the monopoles of the pair and left the other pole to another grain. There is a typical grain size, d , below which a grain would have trapped only one monopole. It is of the order of the distance between the two poles at rest. It depends on the angle between monopoles at production, the range of each of them, etc. It is hard to estimate reliably. However, the contribution to it from multiple scattering can be computed,²⁰ and it represents a minimum for the value of d . It should be of the order of 1 mm in lunar material, for instance, for a pair of monopoles of mass 20 GeV created near threshold.

We consider that the densities of north and of south poles from this process are not correlated statistically if the poles of the pair have been trapped in different grains, because it is believed²¹ that the lunar material has, several times in its existence, been thrown out by meteoritic impact and transported over distances of up to 100 km. In

such displacements the mixing should have been so thorough that neighboring grains would find themselves far apart. There is indeed plenty of evidence that a thorough mixing actually did occur, from analysis of solar wind particles,²² from fossil tracks in dielectric crystals,²³ and from measurement of the neutron exposure.²⁴

To compute the limit for the monopole density due to pair production by incident cosmic-ray protons, we used only the 7.0 kg of material called "sieved fines" and considered the densities of south poles and north poles to be uncorrelated. That selection corresponds to an arbitrary size limit d of less than 1 mm for the particles in the material used; therefore, of the lunar samples run, samples 8, 22, 23, 25, and 28 are disregarded. The maximum density is then 4.7×10^{-4} monopoles/g for a 95% confidence level.

If north and south poles are believed, after production and thermalization, to have been separated by a typical distance d less than 1 mm, only the fraction of material smaller than d mm should be used in this analysis. The curve of Fig. 4 represents the percentage by weight of the fine sample with grain size greater than a given dimension.²⁵ It can be read to find what fraction f of our sample did not meet the requirements, and therefore the fraction $1-f$ by which the above density (and consequently our cross-section limits on Figs. 6 and 8) should be divided.

VI. RADIATION HISTORY OF THE LUNAR SAMPLE

The relations between density and primary monopole cosmic flux on the one hand or between density and pole pair-production cross section on the other hand depend on the history of the samples,²¹ i. e., at what depths they have been over the years. We use the same approximation as do the geologists studying the radiation history of the lunar soil,^{24, 26} i. e., we imagine that its surface has been mixed completely and uniformly down to a depth L during its existence as a solid.

We consider only the time for which the sample has been a solid because--even if monopoles were bound to nuclei¹⁵--there is no insurance that monopoles stopping in a liquid medium would not have drifted and spread into the bulk of the moon. It is safer to count only on the trapping inside solid material. The age of crystallization we use is 3.6×10^9 years.²⁷⁻²⁹

The value of L is estimated by matching the measured exposure age deduced from spallation products. Those products are believed to be produced mostly by high energy cosmic-ray protons of 1 GeV or so. Among all the possible measures of radiation exposure time, spallation products seem the most appropriate for representing exposure of the sample to the high energy primary cosmic-ray flux. Five hundred million years is used as the average of the published ages.³⁰ The corresponding mixing depth L is about 1000 g/cm^2 ,³¹ when cosmic radiation is considered isotropic and not collimated perpendicular to the lunar surface.

The following assumptions are made:

- (a) The collision mean free path is 85.5 g/cm^2 in lunar material.
- (b) The isotropic cosmic-ray flux of protons above an energy E has been constant in time and is given by³²

$$\phi(E) = 1.4 E^{-1.67} \text{ particles/cm}^2\text{-sec-sr}, \quad (13)$$

where E is the kinetic energy in GeV.

(c) At each interaction the incident particle retained 60% of its original energy and continued on in the same direction.³²

(d) The interaction of primary cosmic rays gave rise to a secondary flux capable of producing spallation products. (This flux is normalized to give 0.8 interaction per primary interaction at large depths to match the experimental results for a thick lead target in the atmosphere.³³)

VII. UPPER LIMITS DEDUCED FROM DENSITIES

A. Cosmic Monopole Flux

The efficiency of trapping monopoles depends also on how deeply they penetrated the surface, i. e., on their range R , i. e., on their energy and on the constant N defined by Eq. (9). If north and south monopoles present in the primary cosmic radiation are isotropically distributed and monoenergetic with energy E , the sum of their fluxes per cm^2 per sec per steradian is given by

$$\phi(E) = \frac{(\text{density of monopoles}) \times L}{\pi \times \epsilon(E) \times (T \text{ crystallization})}, \quad (14)$$

where $\epsilon(E)$ corrects for solid-angle effects for large ranges R ;

$$\epsilon(E) = \begin{cases} 1 & \text{for } R < L \\ L^2/R^2 & \text{for } R > L. \end{cases} \quad (15)$$

Using the value³¹ for L and the 95% confidence limit for the density, we get the upper limit for the flux of monopoles in the cosmic rays as a function of E ,

$$\phi(E) < \frac{1.1 \times 10^{-18}}{\epsilon(E)}. \quad (16)$$

In reality, E in Eq. (16) is an average energy of the cosmic monopole, such that $\epsilon(E)$ is the average of the collection efficiencies of the monopoles over their energy spectrum. The result is plotted in Fig. 5 for

different values of N .

B. Pair-Production Cross Section

The limit for the production cross sections, by collision of an incident cosmic-ray proton with a nucleon of the lunar surface, is proportional to the limit for the density of monopoles in the sample, with a factor of proportionality that we derive from a Monte Carlo computation.³⁴ Much of this computation depends on the same parameters as the mixing depth L , in such a way that, because of cancellation effects, much of the error in their determination has little influence on the final result.

In that computation, proton interactions are simulated with the properties listed from (a) to (c) in the preceding section. We neglect monopole production by the secondary flux [condition (d) in the preceding section], therefore we compute an upper limit slightly greater than the real one. In addition, we assume

(a) The cross section σ for each mass M assumed for the monopoles of a pair is constant above threshold and zero below it.

(b) The produced monopoles were emitted in the same direction as the incident proton, with the same velocity as the original nucleon-nucleon system, and with range given by Eq. (10).

The limit for the cross section σ for 95% confidence level is plotted on Fig. 6 as a function of the mass M , for different values of the constant N of Eq. (10). If the distance between two monopoles of a pair is believed to have been typically equal to a value d less than 0.1 cm, then the cross sections should be increased by the factor $1/(1-f)$, where f is the factor read on Fig. 4 for the abscissa equal to d .

Because of our accuracy in the measurement of the magnetic charge, our flux and our cross section limits are valid for any

monopole of charge equal to or larger than g_0 . Those limits are still of the same order of magnitude if the monopole charge is smaller than g_0 but not lower than $0.3 g_0$.

VIII. RESULTS OBTAINED WITH OTHER MATERIALS

Our monopole detector was used also to measure the magnetic charge of other materials. The total mass of materials measured in our detector, including the containers used for lunar material, weighed about 28 kg. Our negative result sets an upper limit of 2×10^{-28} monopoles/nucleon with 95% confidence for the average density of monopoles in all those samples, i. e., for the average density of monopoles in matter.

The nonlunar materials were measured with a number of passes N_p greater than 2000, therefore with an accuracy

$$\delta g < g_0/40. \quad (17)$$

The goal was to detect possible monopoles of charge $g_0/3$, following reports that there could be charges of that magnitude (see Ref. 35, for instance).

Two and four-tenths kg of ocean sediment of the kind analyzed in an earlier experiment³⁵ and an emulsion containing a suspect track, exposed in the same experiment, were available. The ocean sediment was run as eight different samples with $N_p = 2000$, and the emulsion with $N_p = 4000$. All magnetic charges were found consistent with zero and inconsistent with charge $g_0/3$ by more than 10 standard deviations. It should be pointed out, however, that the ocean sediment and the emulsion had been exposed to the very high magnetic fields used in the previous experiment, and our measurement is meaningful only if monopoles are supposed to be bound so strongly to the material that they would have escaped extraction in the strong field.

Portions of various meteorites³⁶ were also available and were run through our detector, with $N_p = 2000$. Again the magnetic charges were found compatible with zero and incompatible with charge $g_0/3$ by more than 10 standard deviations. The total weight analyzed was about 2 kg.

Various materials such as targets exposed to the Brookhaven AGS accelerator and some geological samples were measured with $N_p = 2000$; the same zero results were obtained. A permanent magnet with a north and a south pole of charge 10^3 emu and its keeper were run with $N_p = 100$. The measurement shows that the north and the south pole of that magnet were equal, at least to 1 part in 5×10^{10} .

IX. STATUS OF MONOPOLE SEARCH

Our search has not identified a magnetic monopole, and no other experiment has found one either. All measurements thus give only upper limits for monopole density in various locations. Figure 7 shows some 95% -confidence limits for the sum of the primary fluxes of north and south monopoles in cosmic radiation as a function of the monopole kinetic energy as they are determined by some of the monopole searches.^{35, 37-41} Figure 8 shows some 95% -confidence limits obtained for production cross section in proton-nucleon collisions as a function of the mass of the assumed monopole.^{35, 37-39, 42-45} More results about monopoles have been reported than are shown on Figs. 7 and 8. Some former work can be found in a recent review article.⁴⁶ Limits for pole pair-production cross sections by neutrinos⁴⁷ and γ rays^{9, 37, 38} have been published. Mass- and charge-dependent upper limits for cosmic monopole flux more restrictive than those of Fig. 7 have been estimated from reasonable assumptions concerning the behavior of monopoles in space.⁴¹ Monopoles have been searched for

by studying Cerenkov light emitted by sea-level minimum-ionizing cosmic ray particles.⁴⁸

In different experiments different properties have been assumed for the monopole. They must be believed if the resulting upper limit is to be believed. In order to illustrate the different kinds of experiments that have been done, some of the assumptions involved are listed below. (The list is not claimed to be exhaustive.)

1. Electromagnetic induction and source of magnetic field. The two phenomena are bound together by Lorentz invariance. They constitute a definition of the monopole.
2. Acceleration in magnetic fields. There is a force on the monopole proportional to the value of the magnetic field. That property could be considered as an alternative definition of the monopole.
3. Thermalization. Monopoles are supposed to lose energy in matter by some mechanism such as ionization and be slowed from high velocity down to very low velocities.
4. Migration. After thermalization the monopoles are supposed to move from the point of thermalization through gases or liquids to a collector by some mechanism such as following magnetic field lines.
5. Trapping. After slowing down and perhaps migrating somewhere the monopoles are supposed to be trapped in ferromagnetic or paramagnetic materials by a magnetic binding energy.
6. No binding to atoms or nuclei. Monopoles are supposed not to be bound to atoms or nuclei in nonferromagnetic material.
7. Extraction. Monopoles trapped in a material are supposed to be wrenched out of the material by large magnetic fields.
8. Track signature. Monopoles are supposed to leave characteristic tracks in emulsion or crystals due to their high rate of energy loss.

they would not have been detected unless they produced a very heavy track.

9. Scintillation signature. Large light pulses are required from monopoles traversing scintillators in order for the monopoles to be detected.

10. North pole-south pole separation. North and south poles are supposed to be substantially separated for kinematical reasons after pair production and after slowing down in matter, without the influence of an external magnetic field.

11. Incident cosmic-ray nucleon flux. Whenever pair production by cosmic-ray nucleons is involved, some assumptions have been made on their power spectrum. These assumptions may concern longer or shorter periods of time, depending on the experiment.

12. Interstellar environment. Some consequences rely on assumptions concerning the configuration and the magnitude of the magnetic field in space and the ambient thermal radiation.

13. The asymmetry of magnetic charge. Monopoles are supposed to be mainly of a given sign.

The question of which experiment depends on which property can be answered by reading the original papers. A partial answer is given, to the best of our objectivity, in Tables II to IV--in Table II for some experiments^{35, 37-41} determining limits on the cosmic-ray monopole flux, in Table III for experiments determining pair-production cross-section limits,^{35, 37-39, 42-46} and in Table IV, for experiments^{8, 35, 39, 49} that set limits on density of magnetic monopoles in ordinary matter. The limit obtained per nucleon, with the Dirac charge assumed for the monopole, appears in Table IV. In each table, there is a column corresponding to each experiment (identified by the reference

reporting it). An x in the row corresponding to an assumed property indicates that it was used in that experiment; a v indicates that the assumption concerns only part of the experiment. Also indicated is the range of monopole charge covered (when specified by the authors). The assumptions quoted for each experiment are the ones that have been quoted by the authors themselves.

The main feature of our experiment is that the only properties assumed for the monopoles, aside from their production, stem from their electromagnetic interactions at ranges of 1000 Å or more. The other assumptions necessary for the interpretation concern essentially the radiation history of the moon and are independent of the monopole theory itself.

X. CONCLUSION

Monopoles may not exist. The monopole theory as expressed in Refs. 2, 4, 5, and 7 could actually be disproved experimentally if a small difference were found between the magnitude of the electron and the proton electric charges, because it would require an enormous increase in the unit of magnetic charge quantization according to those theories. Since experiment⁴ limits that difference to less than 10^{-20} times the electron charge, any possible difference would correspond to minimum magnetic charges¹ experiencing forces of more than 3 000 tons in a magnetic field of 1 gauss. If such a difference were ever found, it would certainly be interpreted as a violation of charge quantization and hence as a disproof of the theories referred to above.

However, monopoles may just have been tricky enough to elude all searches to date. According to a recent analysis,⁵⁰ the cross section might be very low for producing pairs of monopoles that would remain separated. It would be necessary to have longer exposure to high energy

particles to be able to isolate a magnetic monopole.

ACKNOWLEDGMENTS

We gratefully acknowledge informative discussions with G. Wasserburg and J. Arnold concerning the history of our lunar samples. We thank H. H. Kolm for providing some of the ocean sediment and an emulsion used in the experiment of Ref. 35, and E. A. King and B. R. Simoneit for supplying our meteorite samples.

For excellent technical support of the experiment we especially thank John Taylor, Maurilio Antuna, Jr., Roscoe Byrns, Glenn Eckman, Leo Foley, Robert Gilmer, Egon Hoyer, and Hans Stellrecht. For support from the Lunar Receiving Laboratory we thank in particular Bryan Erb, Richard Wright, and William Greenwood.

This experiment would not have been possible without the support of J. Naugle, W. N. Hess of NASA, and, of course, of our sample collectors N. Armstrong and B. Aldrin.

FOOTNOTES AND REFERENCES

*Work done under auspices of U. S. Atomic Energy Commission and NASA Contract No. NASA9-8806.

1. L. Alvarez, P. Eberhard, R. Ross, and R. Watt, *Science* 167, 701 (1970) and Supplement I, *Geochim. Cosmochim. Acta* 3, 1953 (1970).
2. P. A. M. Dirac, *Proc. Roy. Soc. (London)* A133, 60 (1931) and *Phys. Rev.* 74, 817 (1948).
3. A. Goldhaber, *Phys. Rev.* 140 B, 1407 (1965).
4. J. G. King, *Phys. Rev. Lett.* 5, 562 (1960); L. J. Fraser, E. R. Carlson, and V. W. Hughes, *Bull. Am. Phys. Soc.* 13, 636 (1968).
5. J. Schwinger, *Phys. Rev.* 173, 1536 (1968) and *Science* 165, 757 (1969).
6. L. W. Alvarez, Lawrence Radiation Laboratory Physics Note 479, 1963 (unpublished); J. Schwinger, *Phys. Rev.* 144, 1087 (1965); D. Zwanziger, *Phys. Rev.* D3, 880 (1971).
7. A. Salam, *Phys. Letters* 22, 683 (1966).
8. L. Vant-Hull, *Phys. Rev.* 173, 1412 (1968).
9. M. I. Blagov, V. A. Murashova, T. I. Syreitshikova, Yu. Ya. Tel'nov, Yu. D. Usachov, and M. N. Yakimenko, Communication to the XVth International Conference on High Energy Physics, Kiev, 1970.
10. R. Omnes (Lawrence Radiation Laboratory), private communication 1964; E. Wichmann (U. C. Berkeley), private communication, 1969.
11. L. W. Alvarez, Lawrence Radiation Laboratory Physics Note 470, 1963 (unpublished).

12. P. Eberhard, Lawrence Radiation Laboratory Physics Note 506, 1964 (unpublished); L. J. Tassie, *Nuovo Cimento* 38, 1935 (1965).
13. E. Goto, *J. Phys. Soc. Japan* 13, 1413 (1958).
14. W. V. R. Malkus, *Phys. Rev.* 83, 899 (1951).
15. D. Sivers, *Phys. Rev.* D2, 2048 (1970).
16. See, for instance, D. W. Strangway, E. E. Larson, and G. W. Pearce, *Science* 167, 691 (1970); G. E. Helsley, *Science* 167, 693 (1970); R. R. Doell, C. S. Gromme, A. N. Thorpe, and F. E. Senftle, *Science* 167, 696 (1970); C. L. Herzenberg and D. L. Riley, *Science* 167, 683 (1970).
17. J. D. Jackson, *Classical Electrodynamics* (John Wiley and Sons, Inc., New York, 1962), p. 438.
18. E. Bauer, *Proc. Cambridge Phil. Soc.* 47, 777 (1951); H. J. D. Cole, *Proc. Cambridge Phil. Soc.* 47, 196 (1951).
19. L. Alvarez, M. Antuna, Jr., R. Byrns, P. Eberhard, R. Gilmer, E. Hoyer, R. Ross, H. Stellrecht, J. Taylor, and R. Watt, *Rev. Sci. Instr.* 42, 326 (1971).
20. P. Eberhard, Lawrence Radiation Laboratory Physics Note 715, 1970 (unpublished).
21. E. M. Shoemaker, M. H. Hait, G. A. Swann, D. L. Schleicher, G. G. Schaber, R. L. Sutton, D. H. Dahlem, E. N. Goddard, and A. C. Waters, Supplement I, *Geochim. Cosmochim. Acta* 3, 2399 (1970).
22. S. H. R. E. L. L. D. A. L. F. F., Supplement I, *Geochim. Cosmochim. Acta* 2, 1503 (1970).
23. R. L. Fleischer, E. L. Haines, H. R. Hart, Jr., R. T. Woods, and G. M. Comstock, Supplement I, *Geochim. Cosmochim. Acta* 3, 2103 (1970).

24. O. Eugster, F. Tera, D. S. Burnett, and G. J. Wasserburg, *Earth Planet. Sci. Letters* 8, 20 (1970); A. L. Albee, D. S. Burnett, A. A. Chodos, O. J. Eugster, J. C. Huneke, D. A. Papanastassiou, F. A. Podosek, G. Price Russ II, H. G. Sanz, F. Tera, and G. J. Wasserburg, *Science* 167, 463 (1970).
25. M. B. Duke, C. C. Woo, G. A. Sellers, M. L. Bird, and R. B. Finkelman, Supplement I, *Geochim. Cosmochim. Acta* 1, 347 (1970).
26. G. J. Wasserburg (California Institute of Technology), private Communication, 1970.
27. The age of crystallization of the Apollo 11 fine materials has been somewhat of a puzzle. Estimates on the basis of U-Pb or Th-Pb decay chains have all given ages between 4.6 and 4.7×10^9 years. (See, for instance, Ref. 28.) However, there are more recent arguments indicating that the age is about 3.6×10^9 years (see Ref. 29).
28. For instance, K. Goplan, S. Kaushal, C. Lee-Hu, and G. W. Wetherill, Supplement I, *Geochim. Cosmochim. Acta* 2, 1195 (1970); M. Tatsumoto, Supplement I, *Geochim. Cosmochim. Acta* 2, 1595 (1970); R. K. Wanless, W. D. Loveridge, and R. D. Stevens, Supplement I, *Geochim. Cosmochim. Acta* 2, 1729 (1970).
29. D. A. Papanastassiou, G. J. Wasserburg, and D. S. Burnett, *Earth Planet. Sci. Letters* 8, 1 (1970); also G. J. Wasserburg (California Institute of Technology), private communication, 1970.
30. P. Eberhardt, J. Geiss, H. Graff, N. Grögler, U. Krähenbühl, H. Schwaller, J. Schwarzmüller, and A. Stettler, Supplement I, *Geochim. Cosmochim. Acta* 2, 1037 (1970); D. Heymann and A. Yaniv, same journal 2, 1247 (1970); C. M. Hohenberg, P. K. Davis, W. A. Kaiser, R. S. Lewis, and J. H. Reynolds, same journal 2, 1283 (1970); T. Kirsten, O. Müller, F. Steinbrunn, and J. Zähringer,

- same journal 2, 1331 (1970); K. Marti, G. W. Lugmair, and H. C. Urey, same journal 2, 1357 (1970).
31. R. Ross, Lawrence Radiation Laboratory Physics Note 730, 1971 (unpublished).
32. We use essentially the approximations of Carithers et al., Ref. 38, p. 1075.
33. M. M. Shapiro, B. Stiller, M. Birnbaum, and F. W. O'Dell, Phys. Rev. 83, 445 (1951).
34. R. Ross, Lawrence Radiation Laboratory Physics Note 733, 1971 (unpublished).
35. Henry H. Kolm, Francesco Villa, and Allen Odian, Phys. Rev. (to be published).
36. The meteorite samples were from the Odessa, M3, Nordheim, Tulia, and Pueblo de Allende Meteorites, Dr. E. A. King Manned Spacecraft Center), private communication, 1969, and Dr. B. R. Simoneit (Space Science Laboratory, U. C. Berkeley), 1969, private communication.
37. E. Goto, H. H. Kolm, and K. W. Ford, Phys. Rev. 132 387 (1963).
38. W. C. Carithers, R. Stefanski, and R. K. Adair, Phys. Rev. 149 1070 (1966).
39. R. L. Fleischer, H. R. Hart, Jr., I. S. Jacobs, P. B. Price, W. M. Schartz, and F. Aumento, Phys. Rev. 184 1393 (1969).
40. R. L. Fleischer, P. B. Price, and R. T. Woods, Phys. Rev. 184, 1398 (1969).
41. W. Z. Osborne, Phys. Rev. Lett. 24, 1441 (1970).
42. E. Amaldi, G. Baroni, A. Manfredini, and H. Bradner, Nuovo Cimento 28 773 (1963).
43. E. M. Purcell, G. B. Collins, T. Fujii, J. Hornbostel, and F. Turkot, Phys. Rev. 129, 2326 (1963).

44. I. I. Gurevich, S. Kh. Khakimov, V. P. Martemianov, A. P. Mishakova, V. V. Ogurtzov, V. G. Tarasenkov, L. M. Barkov, and N. M. Tarakanov, Physics Letters 31B, 394 (1970).
45. V. A. Petukhov and M. N. Yakimenko, Nucl. Phys. 49, 87 (1963). We have used the interpretation according to Ref. 46 of this work in quoting the limit in Fig. 8.
46. E. Amaldi, Search for Dirac Magnetic Poles, in Old and New Problems in Elementary Particles, editor G. Puppi (Academic Press, New York, 1968), pp. 20-61.
47. R. A. Carrigan, Jr., and F. A. Nezrick, Upper Limit for Magnetic Monopole Production by Neutrinos, Phys. Rev. (to be published) (Preprint NAL-44-A, 2022, October 1970).
48. P. J. Green, D. R. Thompkins, and R. E. Williams, Bull. Am. Phys. Soc. 12 190 (1967).
49. K. H. Schatten, Phys. Rev. D1, 2245 (1970).
50. M. A. Ruderman and D. Zwanziger, Phys. Rev. Letters 22, 146 (1969).

Table I. Apollo II samples used in this experiment.

Sample number	NASA number	Weight (g)	Sample number	NASA number	Weight (g)
1	10002,94	298.0	15	10002,107	303.0
2	10002,87	285.0	16	10002,106	296.5
3	10002,86	286.8	17	10002,108	294.0
4	10002,92	293.2	18	10002,109	319.0
5	10002,93	286.2	19	10002,A	301.5
6	10002,89	300.6	20	10002,7A	304.5
7	10002,90	261.5	21	10002,7B	298.5
8	10022,1	213.0	22	10002,4B	318.0
	10023,1		23	10002,4C	297.5
	10024,3		24	10002,5C	356.0
10002,88	10002,4A				
9	10002,88	312.5	25	10002,8B	272.0
10	10002,85	325.8	26	10002,5A	312.0
11	10002,91	300.4	27	10002,5B	316.5
12	10002,96	304.8	28	10002,8A	296.5
13	10002,95	325.8			
14	10002,97	288.8			

Table II. Experiments determining limits for cosmic monopole flux

Assumed property	Reference						This work
	35	37	38	39	40	41	
Electromagnetic induction or source of magnetic flux							X
Acceleration in magnetic field	X	X	X	X		X	
Thermalization	X	X	X	X			X
Migration	X	X	X	X			
Trapping	X	X		X			X
No binding to atoms or nuclei	X						
Extraction	X	X		X			
Track signature		X	V	X	X		
Scintillation signature	X		V				
Interstellar environment							X
Charge range (Dirac units)	0.16 to 27		1 to 3	1 to 30	>2	≥ 1	≥ 0.3

Table III. Experiments determining limits for cross section for pair production by protons.

Assumed property	Reference									This work
	35	37	38	39	42	43	44	45		
Electromagnetic induction or source of magnetic flux										X
Acceleration in magnetic field	X	X	X	X	X	X	X	X		
Thermalization	X	X	X	X		X	X	X		X
Migration	X	X	X	X		X				
Trapping	X	X		X			X	X		X
No binding to atoms or nuclei	X									
Extraction	X	X		X		X	X			
Track signature		X	V	X	X	V	X			
Scintillation signature	X		V			V		X		
North-South separation										X
Cosmic ray flux	X	X	X	X				X		X
Charge range (Dirac units)	0.16 to 27		1 to 3	1 to 30	1 or 2	1				≥ 0.3

Table IV. Experiments determining limits for density in ordinary matter.

Assumed property	Reference				This work
	8	35 ^a	39	49	
Electromagnetic induction or source of magnetic flux	X			X	X
Acceleration in magnetic field		X	X		
No binding to atoms or nuclei		X			
Extraction		X	X		
Track signature			X		
Scintillation signature		X			
Asymmetry of charge				X	
Charge range (Dirac units)	$> 10^{-2}$	0.16 to 27		unlimited	> 0.3
Limit found in monopole/nucleon	10^{-24}	2×10^{-30}	5×10^{-28}	7×10^{-32}	2×10^{-28}

^aFor the value of the density we have used the largest mass mentioned in this paper.

FIGURE CAPTIONS

- Fig. 1. Electric field surrounding the path of a moving monopole.
- Fig. 2. Sample path through the superconducting loop used for magnetic charge measurement.
- Fig. 3. Magnetic charge measurements of samples 1 through 28 of Table I.
- Fig. 4. Submillimeter-fines size distribution according to Ref. 25.
- Fig. 5. Upper limit (95% confidence level) on the flux of cosmic monopoles of a given energy as a function of that energy. The dependence on the parameter N defined by Eq. (9) of the text is illustrated by the curves for $N = 1, 4,$ and 20 .
- Fig. 6. Upper limit (95% confidence level) on monopole pair production cross section in proton-nucleon collisions as a function of assumed monopole mass. The dependence on the parameter N defined by Eq. (9) of the text is illustrated by the curves for $N = 1, 4,$ and 20 .
- Fig. 7. Upper limit (95% confidence level) on the flux of cosmic monopoles as determined in various monopole searches. A from this work; B from Ref. 35; C from Ref. 39; D from Ref. 38; E from Ref. 37; F from Ref. 40. The flux of cosmic ray protons above an energy E as given by Eq. (13) of the text is shown for comparison; for this curve the cosmic-ray kinetic energy E is read on the monopole kinetic energy scale.
- Fig. 8. Upper limit (95% confidence level) on monopole pair production cross section in proton-nucleon collisions as determined in various monopole searches. A from this work; B from Ref. 35; C from Ref. 39; D from Ref. 38; E from Ref. 45; F from Ref. 37; G from Ref. 44; H from Ref. 42; I from Ref. 43.

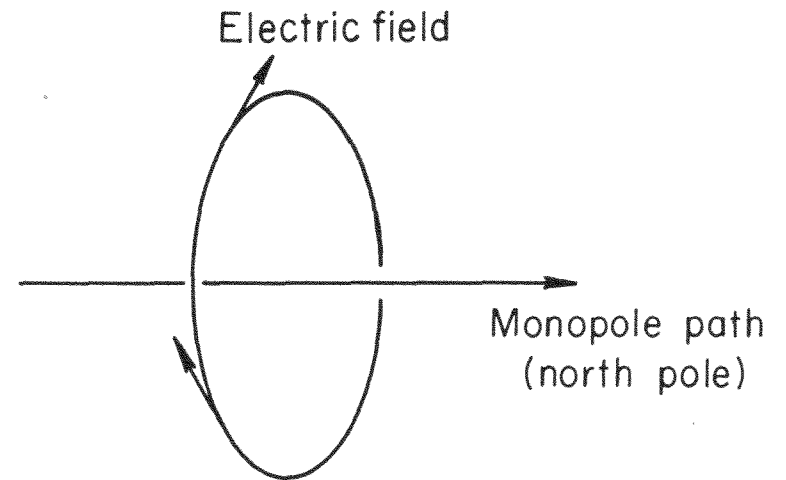

XBL6912-6392

Fig. 1

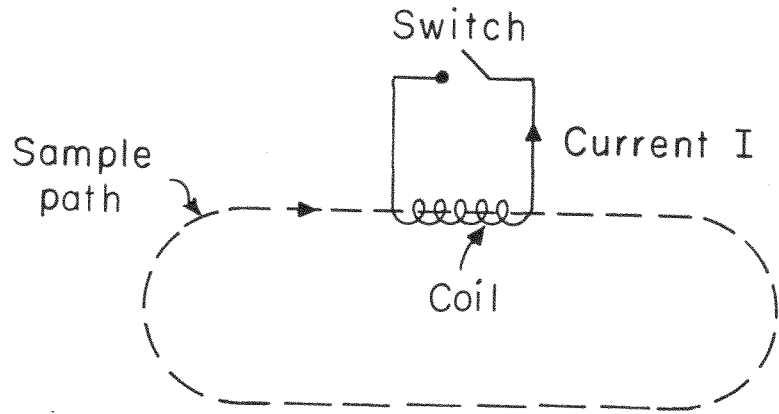

XBL716-3696

Fig. 2

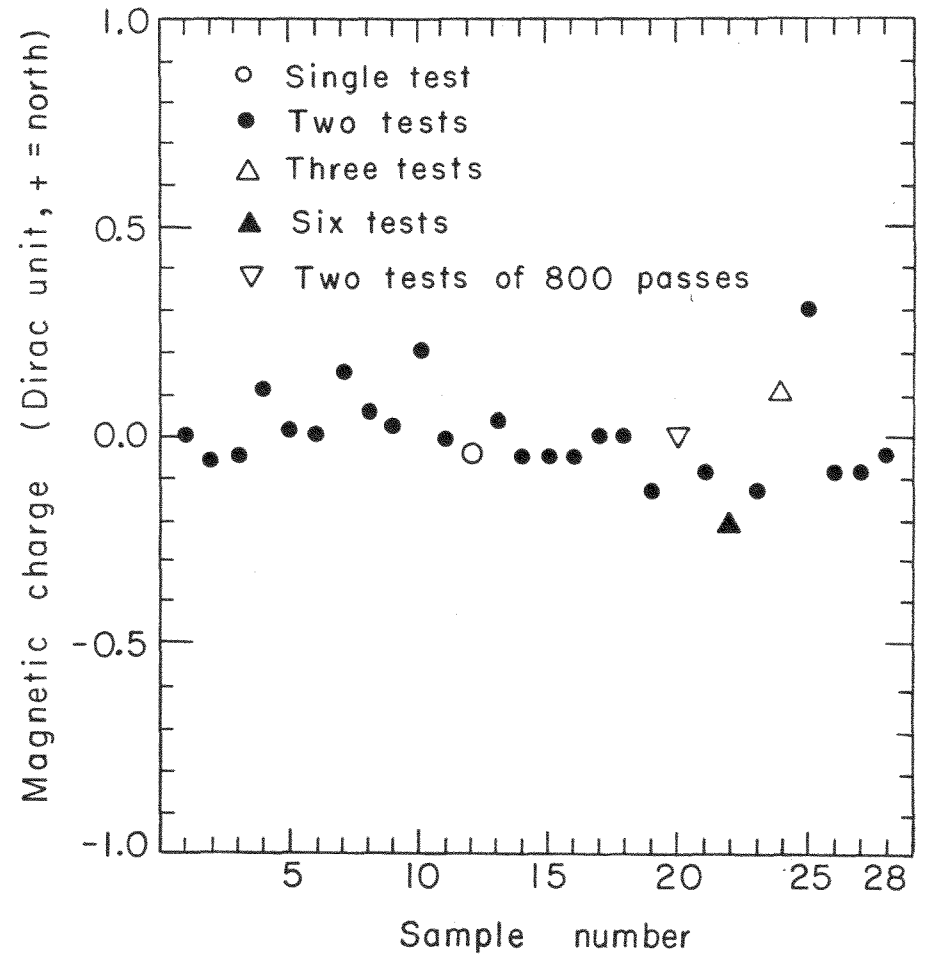

XBL716-3701

Fig. 3

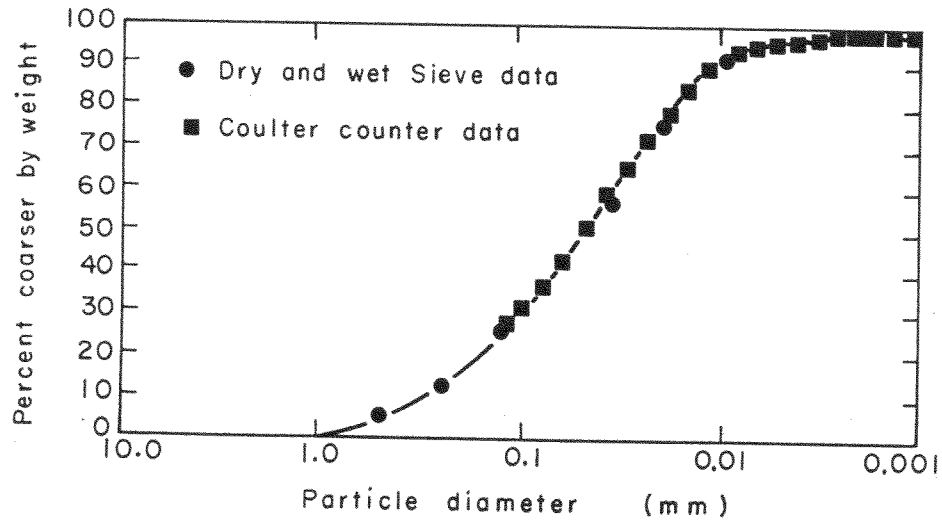

XBL714-614

Fig. 4

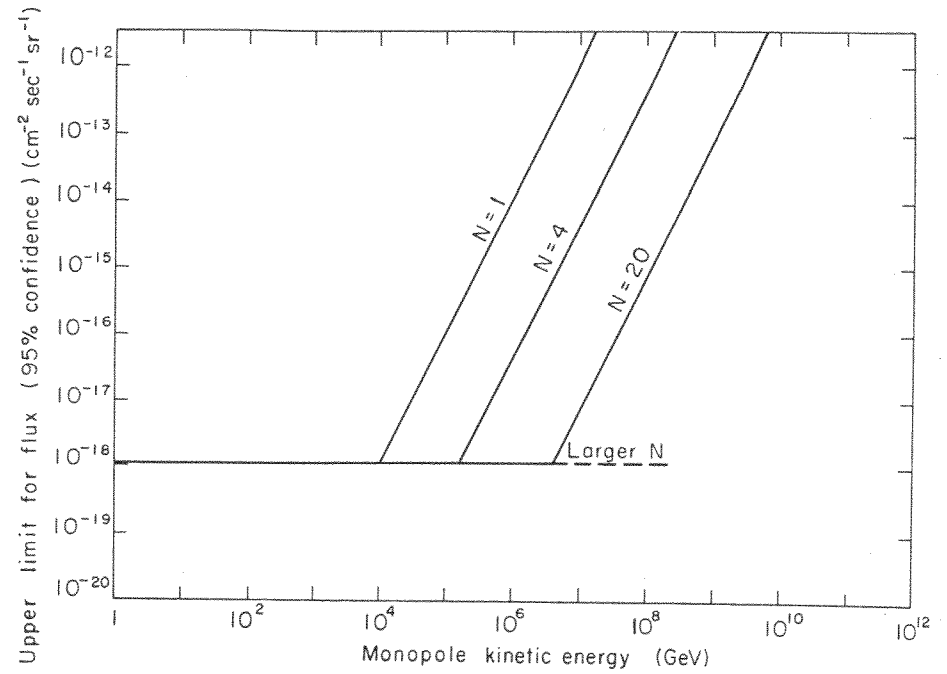

XBL716-3700

Fig. 5

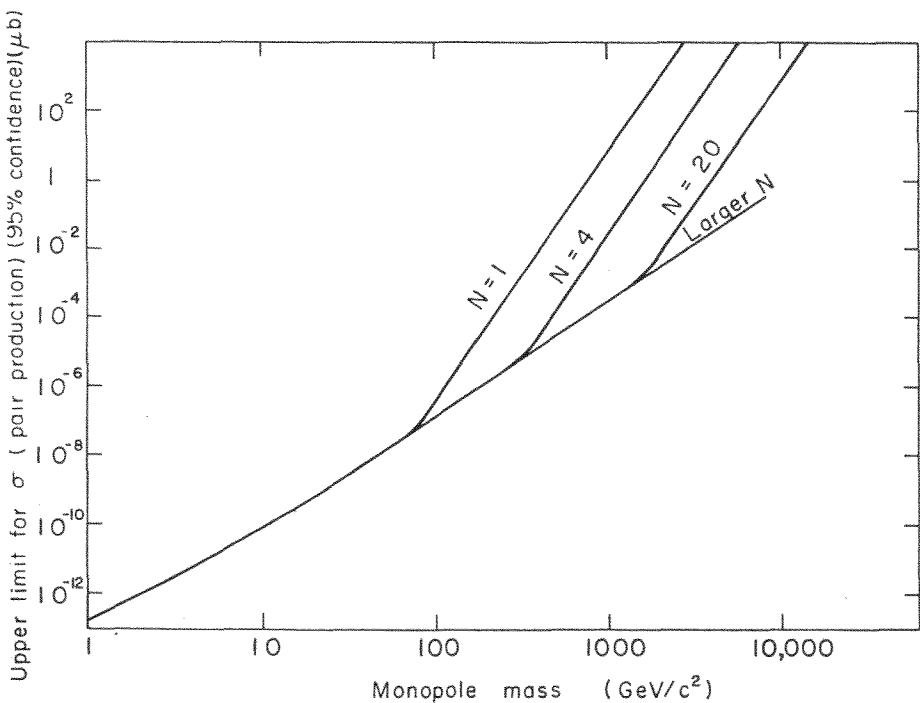

XBL716-3697

Fig. 6

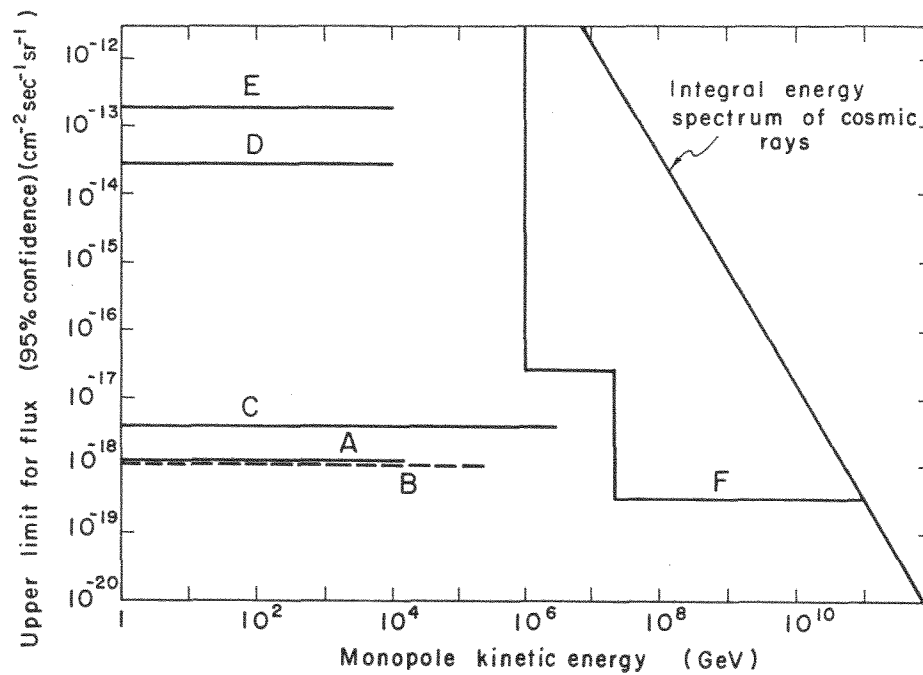

XBL716-3699

Fig. 7

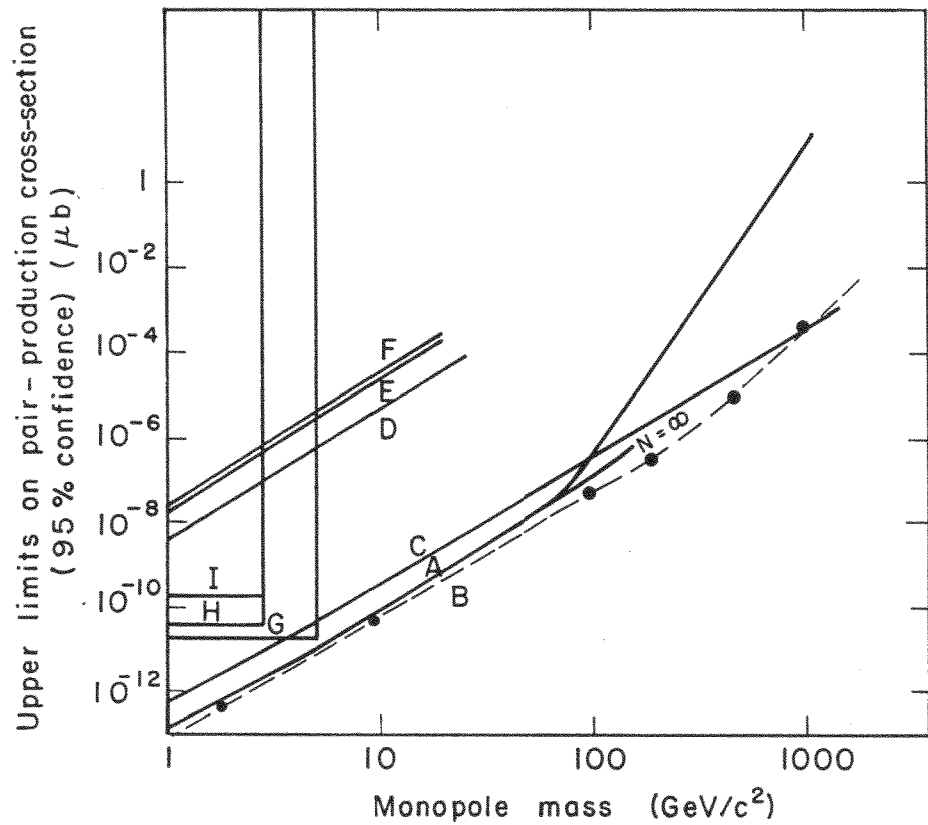

XBL716-3698

Fig. 8

LEGAL NOTICE

This report was prepared as an account of work sponsored by the United States Government. Neither the United States nor the United States Atomic Energy Commission, nor any of their employees, nor any of their contractors, subcontractors, or their employees, makes any warranty, express or implied, or assumes any legal liability or responsibility for the accuracy, completeness or usefulness of any information, apparatus, product or process disclosed, or represents that its use would not infringe privately owned rights.