



ORNL/TM-2005/230

# **POWER ELECTRONICS FOR DISTRIBUTED ENERGY SYSTEMS AND TRANSMISSION AND DISTRIBUTION APPLICATIONS**

L. M. Tolbert  
T. J. King  
B. Ozpineci  
J. B. Campbell  
G. Muralidharan  
D. T. Rizy  
A. S. Sabau  
H. Zhang\*  
W. Zhang\*  
Y. Xu\*  
H. F. Huq\*  
H. Liu\*

December 2005

---

\*The University of Tennessee-Knoxville

**Engineering Science and Technology Division**

**POWER ELECTRONICS FOR  
DISTRIBUTED ENERGY SYSTEMS AND  
TRANSMISSION AND DISTRIBUTION  
APPLICATIONS**

L. M. Tolbert  
T. J. King  
B. Ozpineci  
J. B. Campbell  
G. Muralidharan  
D. T. Rizy  
A. S. Sabau  
H. Zhang  
W. Zhang  
Y. Xu  
H. F. Huq  
H. Liu

Publication Date: December 2005

Prepared by the  
OAK RIDGE NATIONAL LABORATORY  
Oak Ridge, Tennessee 37831  
managed by  
UT-BATTELLE, LLC  
for the  
U.S. DEPARTMENT OF ENERGY  
Under contract DE-AC05-00OR22725

### DOCUMENT AVAILABILITY

Reports produced after January 1, 1996, are generally available free via the U.S. Department of Energy (DOE) Information Bridge.

**Web site** <http://www.osti.gov/bridge>

Not available externally.

Reports are available to DOE employees, DOE contractors, Energy Technology Data Exchange (ETDE) representatives, and International Nuclear Information System (INIS) representatives from the following source.

Office of Scientific and Technical Information  
P.O. Box 62  
Oak Ridge, TN 37831  
**Telephone** 865-576-8401  
**Fax** 865-576-5728  
**E-mail** [reports@adonis.osti.gov](mailto:reports@adonis.osti.gov)  
**Web site** <http://www.osti.gov/contact.html>

This report was prepared as an account of work sponsored by an agency of the United States Government. Neither the United States Government nor any agency thereof, nor any of their employees, makes any warranty, express or implied, or assumes any legal liability or responsibility for the accuracy, completeness, or usefulness of any information, apparatus, product, or process disclosed, or represents that its use would not infringe privately owned rights. Reference herein to any specific commercial product, process, or service by trade name, trademark, manufacturer, or otherwise, does not necessarily constitute or imply its endorsement, recommendation, or favoring by the United States Government or any agency thereof. The views and opinions of authors expressed herein do not necessarily state or reflect those of the United States Government or any agency thereof.

# CONTENTS

	Page
TABLES.....	vii
FIGURES.....	vii
ACRONYMS AND ABBREVIATIONS.....	xi
EXECUTIVE SUMMARY.....	xiv
1. INTRODUCTION.....	1-1
1.1 What is Power Electronics?.....	1-1
1.2 What Are the Applications for Power Electronics Devices?.....	1-1
1.3 Power Electronics Today and Tomorrow.....	1-1
1.4 Power Electronics Benefits to Transmission and Distribution and to Distributed Energy.....	1-3
1.5 Technical Challenges Facing Power Electronics.....	1-4
1.6 Role for Government Support.....	1-5
1.7 DOE Cross-Cut Areas.....	1-5
1.8 Other Agencies Funding Power Electronics.....	1-5
1.9 Organization of Report.....	1-6
2. UTILITY APPLICATIONS OF POWER ELECTRONICS.....	2-1
2.1 Power System Constraints.....	2-1
2.2 FACTS: Building Tomorrow’s Grid within Today’s Footprint?.....	2-1
2.2.1 Comparison of Traditional Solutions and FACTS Solutions.....	2-2
2.2.2 Limitations and Technical Challenges.....	2-5
2.2.3 Investment Costs of FACTS Devices.....	2-6
2.2.4 Organizations Performing Research and Development on FACTS Devices.....	2-8
2.3 High-voltage Direct Current.....	2-9
2.3.1 High-Voltage Direct-Current History.....	2-10
2.3.2 Three Different Categories of High-Voltage Direct-Current Transmissions.....	2-10
2.3.3 Advantages of High-Voltage Direct Current for System Interconnection.....	2-12
2.4 FACTS and High-Voltage Direct Current Systems Benefits Summary.....	2-13
2.4.1 Future Development in FACTS.....	2-14
2.4.2 Future Developments in High-Voltage Direct Current.....	2-15
2.5 Multilevel Inverters.....	2-16
3. POWER ELECTRONICS INTERFACE FOR DISTRIBUTED ENERGY SYSTEMS.....	3-1
3.1 Technical Challenges.....	3-2
3.2 Distribution System Design.....	3-2
3.3 Current Standards.....	3-2
3.4 Economic Challenges.....	3-3
3.5 Analysis Challenges.....	3-3
3.6 DER Systems Reliability.....	3-4
3.7 Dynamic and Local Regulation.....	3-4

3.8	Provision of Ancillary Services .....	3-4
3.9	Recommendations .....	3-5
4.	SILICON POWER ELECTRONIC SEMICONDUCTORS .....	4-1
4.1	Historic Review of Development of Silicon Power Electronic Devices .....	4-2
4.2	Overview of Silicon Power Electronic Devices .....	4-3
4.2.1	Thyristor .....	4-4
4.2.2	GTO and IGCT .....	4-4
4.2.3	MOSFET .....	4-5
4.2.4	IGBT .....	4-6
4.2.5	MOS-Controlled Thyristor .....	4-7
4.2.6	Emitter Turn-Off Thyristor .....	4-7
4.2.7	Other Novel Device Structures .....	4-8
4.3	Power Device Manufacturers .....	4-10
4.4	New Materials Usage .....	4-10
4.5	Innovation in Design of Power Electronics System as a Whole .....	4-12
5.	WIDE BANDGAP POWER ELECTRONICS .....	5-1
5.1	Challenges of Silicon Semiconductor Technology .....	5-1
5.2	New Materials for Power Electronic Devices .....	5-3
5.3	Characteristics of Wide Bandgap Devices .....	5-3
5.3.1	Bandgap vs. Breakdown Voltage .....	5-4
5.3.2	Bandgap, Thermal Conductivity vs. Maximum Operational Temperature .....	5-5
5.3.3	Electric Breakdown Field vs. Drift Region Width .....	5-5
5.3.4	On-Resistance .....	5-5
5.3.5	Drift Velocity vs. Switching Speed .....	5-5
5.3.6	Figures of Merit .....	5-6
5.4	System Benefits of Wide Bandgap Devices and Potential Applications .....	5-6
5.5	Silicon Carbide .....	5-6
5.5.1	SiC-Based Power Electronics .....	5-8
5.5.2	Overview of SiC Wafer Industry .....	5-8
5.5.3	Commercially Available SiC Devices and Research Activities .....	5-10
5.5.4	Challenges for SiC Semiconductor Technology .....	5-15
5.6	GaN Devices .....	5-16
5.6.1	Overview of GaN Semiconductor Technology .....	5-17
5.6.2	Material Technology of GaN .....	5-18
5.6.2.1	GaN wafers .....	5-18
5.6.2.2	GaN substrat .....	5-19
5.6.2.3	GaN material challenges .....	5-19
5.6.3	GaN Power Devices .....	5-20
5.6.4	Comparison between GaN and SiC .....	5-20
5.7	Diamond Devices .....	5-22
5.7.1	Research on Diamond Devices .....	5-22
5.7.3	Critical Technology Concerns .....	5-24
5.8	Summary .....	5-26
5.9	Strategic Research Needs in Wide Bandgap Semiconductors .....	5-26
6.	SUPPORTING TECHNOLOGIES FOR POWER ELECTRONICS .....	6-1
6.1	Thermal Management .....	6-1
6.1.1	Thermal Model .....	6-1
6.1.2	Present R&D Status .....	6-3

6.1.3	Thermal Management Industry .....	6-4
6.1.4	Technical Challenges—Areas of R&D needs .....	6-5
6.2	Packaging of Power Electronics .....	6-7
6.2.1	Requirements of A High-Temperature Package .....	6-8
6.2.2	Elements of A Typical High-Temperature Package.....	6-8
6.2.3	Ongoing Development Efforts .....	6-10
6.2.4	Future Research Needs.....	6-11
7.	RESEARCH NEEDS FOR POWER ELECTRONICS TO IMPACT THE GRID.....	7-1
7.1	Transmission and Distribution Applications .....	7-1
7.2	Wide Bandgap Semiconductors .....	7-3
7.3	Thermal Management.....	7-4
7.4	Packaging .....	7-5
8.	REFERENCES.....	8-1
Appendix A.	GLOSSARY.....	A-1
Appendix B.	PRINCIPLES OF OPERATION FOR FACTS DEVICES AND HVDC.....	B-1
Appendix C.	SILICON POWER SEMICONDUCTOR DEVICES .....	C-1
Appendix D.	SiC POWER ELECTRONIC DEVICES .....	D-1
Appendix E.	INTRODUCTION OF SEMICONDUCTOR MANUFACTURING PROCESS .....	E-1

## TABLES

<b>Table</b>		<b>Page</b>
2.1	Advantages and disadvantages of FACTS devices .....	2-5
2.2	EPRI FACTs research topics.....	2-8
4.1	Available self-commutated power semiconductor devices .....	4-4
4.2	High-power electronics manufacturers and products .....	4-11
5.1	Physical characteristics of Si and the main wide bandgap semiconductors .....	5-3
5.2	Advantages of wide bandgap devices .....	5-4
5.3	Main figures of merit for wide bandgap semiconductors compared with silicon .	5-6
5.4	Commercially available SiC wafers .....	5-9
5.5	Commercially available SiC devices.....	5-10
5.6	Prototypes (future products) developed by manufacturers.....	5-10
5.7	Current research in agencies and universities .....	5-11
5.8	GaN device market.....	5-17
5.9	Breakdown voltage and depletion layer with doping concentration (boron) .....	5-23
6.1	Cooling technologies developed for Si device.....	6-5
6.2	Present programs and active areas of R&D.....	6-5
7.1	Recommendations for DOE to fund power electronics.....	7-1
B.1	Steady state application of FACTS .....	B-2
B.2	Dynamic applications of FACTS .....	B-3
B.3	SVC installation list in the U.S. ....	B-5
B.4	STATCOM installations sample (in the U.S.).....	B-8
B.5	CSC configurations and MVA ratings .....	B-17
B.6	CSC general specifications summary.....	B-18
D.1	SiC power rectifiers that have been demonstrated experimentally .....	D-2
D.2	Prototype SiC power transistors that have been demonstrated experimentally.....	D-5
D.3	SiC thyristors that have been demonstrated experimentally .....	D-7
D.4	GTO/diodes converter specification.....	D-7
D.5	Simulation results for Si/SiC/hybrid converter efficiency from paper.....	D-8
D.6	System savings of different converters (per year).....	D-8

# FIGURES

Figure		Page
1.1	Block diagram of a power electronic system .....	1-1
1.2	Voltage and current rating for different power electronics application areas. ..	1-2
1.3	Various cost-benefit studies showing annual savings from increased reliability and reduced transmission congestion.....	1-4
1.4	Power electronics systems.....	1-7
2.1	Example of transmission bottlenecks .....	2-2
2.2	Development and relationship of conventional and FACTS devices.....	2-3
2.3	Illustration of how FACTS can increase transmission capability by raising the damping limits and transient stability limits.....	2-4
2.4	Solutions for enhancing power system control .....	2-5
2.5	Breakdown of costs for a thyristor-based and a converter-based FACTS installation.....	2-6
2.6	Typical investment costs for SVC/STATCOM.....	2-7
2.7	Typical investment cost for series compensation (SC), thyristor-controlled series compensation (TCSC), and UPFC .....	2-7
2.8	EPRI-sponsored FACTS installations in the United States.....	2-9
2.9	Worldwide installed capacity of HVDC links.....	2-9
2.10	Monopolar HVDC.....	2-10
2.11	Bipolar HVDC.....	2-11
2.12	Back-to-back HVDC .....	2-11
2.13	Multiterminal HVDC .....	2-12
2.14	HVDC lines in North America.....	2-12
2.15	Single-phase structure of a multilevel cascaded H-bridge inverter (a) Circuit diagram (b) Waveforms and switching method of the 11-level cascade inverter .....	2-17
4.1	Power semiconductors focus areas.....	4-1
4.2	Realm of power electronics technologies.....	4-2
4.3	Today's device capabilities and application needs (a) Comparison of today's devices application fields and regions of operation and (b) Voltage and current requirements for devices per region of operation.....	4-3
4.4	4500 V/800 A and 4500 V/1500 A thyristors .....	4-5
4.5	4500 V/800 A and 4500 V/1500 A GTOs.....	4-5
4.6	6500-V/1500-A symmetrical GCT.....	4-5
4.7	Silicon MOSFET with ratings of 150 V/600 A.....	4-6
4.8	1700-V/1200-A and 3300 V/1200 A IGBT modules .....	4-7
4.9	A cross sectional structure of a p-type MCT with its circuit scheme.....	4-8
4.10	4000 A/4500 V ETO with the integrated gate driver .....	4-8
4.11	Market share of semiconductor devices (University of Florida, Gainesville ....	4-9
4.12	Future MOS devices with silicon technologies (University of Florida, Gainesville) .....	4-9
4.13	Device structure of MOSFETs.....	4-10
5.1	The advance in power handling capacity of IGBT switches between 1983 and 1998 (a) and improvements in GTO thyristors over the past decade (b) .....	5-2



5.2	Maximum breakdown voltage of a power device at the same doping density normalized to Si .....	5-4
5.3	Maximum operational temperature assuming that it is 150°C for Si .....	5-4
5.4	Width of the drift region for each material at different breakdown voltages ....	5-4
5.5	Resistance of the drift region for each material at different breakdown voltages.....	5-4
5.6	Comparison of wide bandgap and SiC power electronics for power applications.....	5-7
5.7	Power network of the future. SiC may be used where yellow inverters are highlighted.....	5-7
5.8	Typical cost breakdown for SiC devices .....	5-15
5.9	Electronic properties of GaN-based devices .....	5-17
5.10	Commercial opportunities for GaN .....	5-18
5.11	Reverse recovery performance .....	5-21
5.12	Diagram of power diode structure: (a) Medal semiconductor structure and (b) Medal insulated semiconductor structure .....	5-23
6.1	Schematic of thermal management systems.....	6-2
6.2	A simplified thermal management system with finned heat sink.....	6-2
6.3	System-level simulation model of the heat sink system in Fig. 6.2 .....	6-2
6.4	Thermacore heat pipe technology for (a) a capacitor, (b) Fins are stacked on the heat pipes to provide adequate surface area for heat dissipation to the air.	6-3
6.5	The powdered metal cold plate heat transfer matrix .....	6-4
6.6	Maximum heat flux removed (working fluids and technologies) .....	6-4
6.7	A modern thermal management design algorithm .....	6-7
6.8	Schematic of a typical state-of-the-art package used for packaging an SiC die for high-temperature use .....	6-9
6.9	Summary of anticipated R&D needs for packaging of wide bandgap devices .	6-11
A.1	Semiconductor band structure .....	A-1
A.2	The typical current flow and voltage response of a diode.....	A-2
B.1	Circuit for a static var compensator (SVC) .....	B-4
B.2	V-I characteristics of a SVC.....	B-4
B.3	STATCOM operation principle.....	B-7
B.4	V-I characteristics of a STATCOM .....	B-7
B.5	VELCO Essex S/S –41/+133Mvar, 115kV STATCOM System .....	B-10
B.6	SDG&E Talega –100/+100 Mvar, 138 kV STATCOM/BTB System .....	B-11
B.7	Circuit for a TCSC .....	B-12
B.8	Circuit for SSSC.....	B-13
B.9	Basic circuit for a unified power flow controller (UPFC).....	B-13
B.10	Control modes of the series compensator.....	B-14
B.11	Interline power flow controller comprising $n$ converters .....	B-15
B.12	Phase angle regulator.....	B-16
B.13	Simplified schematic of the convertible static compensator .....	B-16
B.14	American Superconductor’s SuperVAR dynamic synchronous condenser .....	B-20
B.15	Layout of a typical HVDC converter station.....	B-21
D.1	SiC power electronics components .....	D-1
D.2	Structures of SiC power rectifiers .....	D-2
D.3	Basic structure of SiC MOSFETs .....	D-3

D.4	Basic structures of SiC JFET.....	D-3
D.5	Two normally-off structures of SiC JFET.....	D-4
D.6	Structures of SiC BJTs.....	D-5
D.7	Equivalent circuits for proposed SiC devices.....	D-5
D.8	Cross-section of asymmetrical SiC GTO.....	D-7
D.9	Absolute on-current vs. blocking voltage for SiC power devices reported as of 2004.....	D-7
E.1	The basic steps of device manufacturing process (Infrastructure).....	E-1
E.2	The basic steps of Si manufacturing process.....	E-2
E.3	The basic steps of SiC manufacturing process.....	E-3
E.4	The principle of SiC CVD.....	E-3
E.5	Fabrication concept for high-power SiC devices.....	E-4
E.6	The basic steps of GaN manufacturing process.....	E-4
E.7	GaN-on-sapphire: Conventional growth process (TDI).....	E-5
E.8	The basic steps of Diamond manufacturing process.....	E-5
E.9	Diamond Synthesis (CVD Process).....	E-6
E.10	Diamond Synthesis.....	E-6
E.11	CVD synthesis (the Apollo way).....	E-7

## ACRONYMS AND ABBREVIATIONS

ABB	ASEA Brown Bover
AC	alternating current
AEPS	Advanced Electrical Power Systems
AFRL	Air Force Research Laboratory
AMSC	American Superconductor Corporation
ASD	adjustable speed drives
BES	battery energy storage
BESS	battery energy storage system
BJT	bipolar junction transistors
BTB	back to back
CAES	compressed air energy storage
CES	capacitor energy storage
CPES	Center for Power Electronics Systems
CSTBT	carrier-stored trench bipolar transistor
CSC	convertible static compensator
CSC	current source converter
CSPA	Center for Space Power and Advanced Electronics
CSWS	Central and South West Services
CVD	chemical vapor deposition
DARPA	Defense Advanced Research Projects Agency
DBC	direct bonded copper
DC	direct current
DCCSS	Dow Corning Compound Semiconductor Solutions
DE	distributed energy
DER	distributed energy resources
DG	distributed generation
DI	diffusion isolation
DMOSFET	double-diffused MOSFET
DoD	Department of Defense
D-SMES	distributed SMES
D-STATCOM	distribution-STATCOM
D-Var	dynamic var
EMI	electromagnetic interference
EPRI	Electric Power Research Institute
EST	emitter-switched thyristor
ETO	emitter turn-off thyristor
FACTS	flexible ac transmission systems
FC	fuel cell
FCT	field-controlled transistor
FCTh	field-controlled thyristor
FET	field-effect transistor
FERC	Federal Energy Regulatory Commission
FES	flywheel energy storage
FOM	figures of merit
FRED	fast recovery diode
GaN	gallium nitride
GCT	gate commutated turn-off thyristor
GDP	gross domestic product

GTO	gate turn-off thyristor
HBT	heterojunction bipolar transistor
HEMTS	high electron mobility transistors
HFETs	heterojunction field-effect transistor
HPE	high-power electronics
HPHE	heat-pipe heat exchangers
HPHS	heat-pipe heat sinks
HPS	heat-pipe spreaders
HV	high voltage
HVDC	high-voltage direct current
HV-HF	high voltage, high frequency
HVPE	hydride vapor-phase epitaxy
IC	integrated circuits
IEGT	injection-enhanced (insulated) gate transistor
IGBT	insulated-gate bipolar transistor
IGCT	integrated-gate commutated thyristor
IGT	insulated-gate thyristor
IGTT	insulated gate turn-off thyristor
IPFC	interline power flow controller
IR	International Rectifier
JBS	junction barrier Schottky
JFET	junction field effect transistor
LED	light-emitting diodes
LV	low voltage
MCT	MOS-controlled thyristor
MGT	MOS-gated transistor
MHP	mini/micro heat pipes
MMC	metal matrix composite
MOS	metal oxide semiconductor
MOSFET	metal oxide semiconductor field effect transistor
MPS	merged pin/Schottky
MTO	Microsystems Technology Office
MTO	MOS turn-off thyristor
MW	megawatts
NASA	National Aeronautics and Space Administration
NSF	National Science Foundation
NIST	National Institute for Standards and Technology
NU	Northeast Utilities
OEDER	Office of Electricity Delivery and Energy Reliability
ONR	Office of Naval Research
PMCP	powdered metal cold plate
PCS	power conversion system
PEBB	power electronics building block
PECVD	plasma-enhanced chemical vapor deposition
PF	power factor
PSS	power system stabilizer
PVT	physical vapor transport
PWM	pulse width modulation
RB-IGBT	reverse blocking IGBT
RBSOA	reverse biased safe operation area
RC-IGBT	reverse conducting IGBT

RF	radiofrequency
RIPE	robust integrated power electronics
RMS	root mean square
RPI	Rensselaer Polytechnic Institute
RTO	regional transmission organization
SBD	Schottky barrier diode
SC	series compensation
SCCL	superconducting current limiter
SDG&E	San Diego Gas and Electric
SEJFET	static expansion channel JFET
Si	silicon
SiC	silicon carbide
SIT	static induction transistor
SITh	static induction thyristor
SJ	super-junction
SMES	superconducting magnetic energy storage
SOA	safe operating area
SOP	system-on-package
SSG	static synchronous generator
SSR	sub-synchronous resonance
SSSC	static synchronous series compensator
STATCOM	static synchronous compensator
STS	static transfer switch
SVC	static var compensator
SVS	synchronous voltage sources
TCPAR	thyristor-controlled phase-angle regulator
TCPST	thyristor-controlled phase-shifting transformer
TCSC	thyristor-controlled series compensation
TCVL	thyristor-controlled voltage limiter
T&D	transmission and distribution
TI	trench isolation
TIM	thermal interface material
TMBS	trench MOS barrier Schottky
TSBS	trench Schottky barrier Schottky
TSC	thyristor switched capacitor
TSR	thyristor switched reactor
TSSC	thyristor-switched series capacitor
TVA	Tennessee Valley Authority
UCL	University College, London
UMOSFET	u-shape MOSFETs
UPFC	unified power flow controllers
VJFET	vertical junction field effect transistor
VSC	voltage source converter
WAPA	Western Area Power Administration
WBG	wide bandgap

## EXECUTIVE SUMMARY

Power electronics can provide utilities the ability to more effectively deliver power to their customers while providing increased reliability to the bulk power system. In general, power electronics is the process of using semiconductor switching devices to control and convert electrical power flow from one form to another to meet a specific need. These conversion techniques have revolutionized modern life by streamlining manufacturing processes, increasing product efficiencies, and increasing the quality of life by enhancing many modern conveniences such as computers, and they can help to improve the delivery of reliable power from utilities. This report summarizes the technical challenges associated with utilizing power electronics devices across the entire spectrum from applications to manufacturing and materials development, and it provides recommendations for research and development (R&D) needs for power electronics systems in which the U.S. Department of Energy (DOE) could make a substantial impact toward improving the reliability of the bulk power system.

### Overview of Power Electronic Devices

Power electronics can be found in many forms within the power system. These forms range from high-voltage direct current (HVDC) converter stations to the flexible ac transmission system (FACTS) devices that are used to control and regulate ac power grids, variable-speed drives for motors, interfaces with storage devices of several types, interfacing of distributed energy resources with the grid, the electric drive in transportation systems, fault current-limiting devices, the solid-state distribution transformer, and transfer switches.

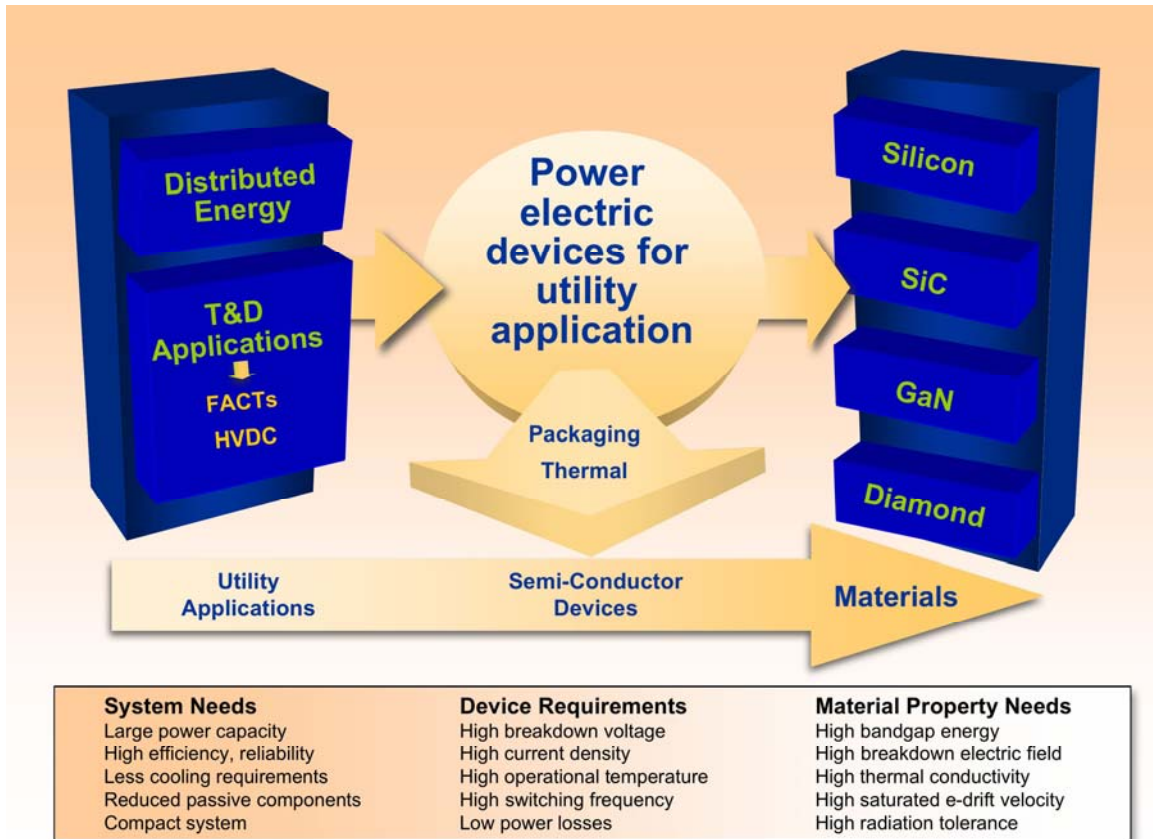
Power electronics can play a pivotal role in improving the reliability and security of the nation's electric grid. Although it is very difficult to quantify reliability benefits, studies show the estimated present value of aggregated attributes of a reliable, modernized grid to be \$638–802 billion over a 20-year horizon, with annualized values of between \$51 and 64 billion/year. With that said, power electronics are not considered ideal systems. Some of the important issues that power electronics encounter include cost, reliability, component packaging and thermal management, cooling methods, efficiency, and control. Many players in the power electronics field are striving to overcome these deficiencies. DOE could impact the power electronics industry as a whole by leveraging the research presently funded and identifying research needs that are unfunded.

### Utility Applications of Power Electronics

High-power electronic devices will play an important role in improving grid reliability, including use in energy storage systems, FACTS applications, distributed energy (DE), and HVDC. This report breaks down the applications into two main sections:

- Transmission and distribution applications of FACTS
- Distributed energy interfaces

The U.S. transmission system continues to incur a growing number of constraints. Growth in electricity demand and new generation, lack of investment in new transmission facilities, and the incomplete transition to fully efficient and competitive wholesale markets have allowed transmission bottlenecks to emerge. Deregulation has enabled power delivery within and between regions and facilitates access to interconnected competitive generation. However, the existing system is not designed for open-access power delivery, creating inefficiencies in power delivery.



Additionally, there are few or no market-based incentives for transmission investment, which has contributed to system capacity deficiencies.

A recent Federal Energy Regulatory Commission (FERC) study identified 16 major transmission bottlenecks in the United States for 2004 summer flow conditions. These bottlenecks cost consumers more than \$1 billion over the past two summers, and it is estimated that \$12.6 billion is needed to correct the identified bottlenecks. Obviously, upgrading and enhancing an infrastructure that is aging and not designed to carry out the transactions being demanded of it in today's world will require a great deal of financial support.

The challenge facing the power system engineer today is to use existing transmission facilities to greater effect. Improved utilization of the existing power system is provided through the application of advanced control technologies in power electronics-based equipment, or FACTS. FACTS provide proven technical solutions to address new operating challenges being presented today. With that said, FACTS are much too expensive to purchase, install, and maintain in the current utility systems. The cost of FACTS devices has been a major hurdle for commercialization in the United States. For example, the cost of a static Var compensator is twice that of a capacitor bank with the same rating, and the cost of static synchronous compensators is three times that of traditional technologies. Utilities are waiting for reductions of the costs of FACTS devices.

Distributed generation (DG) applications today are primarily for niche markets where additional power quality is desired or local onsite generation is desired. In some cases, the distributed energy resource (DER) is designated for backup and peak power shaving conditions. Frequently, these generators are in an inoperative state for long periods until the needs of the load or the local utility require additional generation. Thus DG is costly to install, maintain, and operate for most commercial customers. Many DER systems are costly to install because there is

no standard installation process and because additional overcurrent and overvoltage protection hardware is required by the utility. The capital cost of many of the new technologies such as microturbines, which use clean natural gas, is double the cost of conventional diesel power generator sets. DE is cost-effective in some niche markets where the electricity cost is extremely high, such as Hawaii and the Northeast, or where outage costs are costly. Two directions for achieving cost-effectiveness for DER are reducing the capital and installation costs of the systems and taking advantage of additional ancillary services that DE is capable of providing. A market for unbundled services (ancillary services) would promote installation of DG where costs could not be justified based purely on real power generation.

Power electronics currently are used to interface certain DER such as fuel cells, solar cells, and microturbines to the electric power grid. Power electronics are used to convert high-frequency ac or dc voltage supplied by the DE source to the required 60-Hz ac voltage of the grid. However, power electronics also offer significant potential to improve the local voltage regulation of the grid that will benefit both the utility and the customer-owned DE source. Basically, power electronics for DER are in their infancy. Power electronics offer the conversion of real power to match the system voltage and frequency, but this interface could do much more. For example, the power electronics could be designed to produce reactive power by varying the phase shift in the voltage and current waveforms from the power electronics. Also, various controls could be built into the power electronics so the DE can respond to special events or coordinate its operation with other DE sources on the distribution system.

## **Silicon Power Electronic Semiconductors**

The development of advanced power electronic devices has been accelerated as a result of the emergence of changes and breakthroughs achieved in the areas of power semiconductor device physics and process technology. The fundamental building block of power electronic devices is the power semiconductor. Power semiconductors are essential components of most electronic devices and systems. Silicon is by far the most widely used semiconductor material.

Power semiconductors primarily consist of self-commutated or “controllable switched” devices. Self-commutated power semiconductor devices can be classified into one of two categories: thyristors or transistors. Thyristors are switches composed of a regenerative pair of transistors. Once the regenerative action is initiated (or interrupted), the thyristor switches very rapidly from “off” to “on”; and the gate unit exercises little, if any, control over the speed at which this occurs. Transistors are amplifiers that can allow large collector currents to be varied by a small controlling base current in conventional bipolar transistors or, in the more sophisticated insulated gate bipolar transistors (IGBTs) or metal oxide semiconductor field effect transistors (MOSFETs), by a gate voltage requiring very little current and hence little control power. The gate control circuit can vary the speed at which switching on or off occurs. The devices in the high-power application fields under serious consideration for the present are thyristors, IGBTs, GTOs, and integrated gate-commutated transistors (IGCTs).

Power semiconductor devices belong to a separate segment of the mass semiconductor application market and are mainly sold as discrete devices or modules in the marketplace, differing both in production technology and in end-user applications. These devices are aimed to receive, process, and switch from a few watts to megawatts as quickly and efficiently as possible. The power semiconductor industry has changed significantly in the past decade.

Today, approximately 80 power semiconductor manufacturers are serving the North American market. Their products consist mainly of thyristors, transistors, rectifiers, and power integrated circuit devices. The power electronic devices with voltage and current ratings of more than 1000 V/100 A that are available from power semiconductor device manufacturers are listed in Chapter 4.



Major advances in the next generation of power electronic device technologies will depend mainly on finding solutions to multidisciplinary issues in materials, circuits, system integration, packaging, manufacturing, marketing and applications.

## Wide Bandgap Power Electronics

Having the most advanced and mature technology for power electronics devices, silicon (Si) power devices can be processed with practically no material defects. However, Si technology has difficulty meeting the demand for some high-power utility applications as a result of limitations in its intrinsic material properties. The primary limitation of Si devices is voltage blocking capacity because of Si's relatively narrow bandgap (1.1 eV), which limits the voltage blocking capacity of most Si devices to less than 10 kV. For high-voltage applications, stacking packaged devices in series is required. Series stacking is expensive from a packaging standpoint, and it requires complicated triggering to maintain voltage-sharing between devices in the stack. Hence there is a strong incentive to develop devices having greater voltage blocking capacity in the same or a smaller device package. Such devices could be used in a variety of utility switching applications, from distribution levels (tens of kV) to transmission levels (>100 kV). Many of these applications are aimed at improving power quality and reliability and fall in the category of FACTS or HVDC.

Low thermal conductivity limits the operational temperature of Si devices. The normal operational temperature limit is less than 150°C, and a significant thermal management effort is required to maintain the junction temperature of these devices below that limit. There are three standard options for cooling power devices—natural air, forced air, or water-cooled heat sinks. Manufacturing power electronic devices that can withstand higher temperatures is one way of decreasing the cooling requirements, size, and cost of the converter.

Wide bandgap semiconductor materials have superior electrical characteristic compared with Si. Power electronic devices based on wide bandgap semiconductor materials will likely result in substantial improvements in the performance of power electronics systems in terms of higher blocking voltages, efficiency, and reliability, as well as reduced thermal requirements.

The superior properties of SiC material result in a series of superior performances of power electronics made of SiC. Consequently, systems based on SiC devices show substantial improvements in efficiency, reliability, size, and weight, even in harsh environments. Therefore, they are especially attractive for high-voltage, high-temperature, high-efficiency, or high-radiation uses, such as military, aerospace, and energy utility applications.

Cree dominates SiC wafer production with about 85% of the market share. Around 94% of SiC wafer production is in the United States, 4% is in Asia, and 2% is in Europe. Presently, 4-in. SiC wafers and 2-in. semi-insulating wafers are available. Micropipe density is the main limitation on the size of the SiC wafer. The best-quality commercially available wafer has a micropipe density of less than 5 cm<sup>-2</sup>. This allows an active area of about 20 mm<sup>2</sup>. However, a micropipe density of less than 1 cm<sup>-2</sup> is required to realize devices with current ratings larger than 100 A. Currently, all industrial-standard wafers are produced by an approach called physical vapor transport, but this technology is far from mature.

High-temperature, high-power-density packaging techniques are required to take full advantage of SiC capabilities. The currently available packaging techniques are for applications of Si devices, which generally have a power density limit of 200 W/cm<sup>2</sup> and/or a use temperature of less than 125°C, while an SiC device may require a power density of 1,000 W/cm<sup>2</sup> and /or a use temperature of 250°C or more.

While so far gallium nitride (GaN) has been explored for optoelectronic and radio frequency applications, it also offers significant advantages for power-switching devices because of the availability of band engineering in III-nitride materials. In fact, the ongoing development of GaN-based devices for optoelectronic and RF applications allows the natural extension of this

technology into the power electronics field. In comparison with SiC, the availability of band engineering for III-nitride materials allows device operation at higher speed and at much higher current density.

GaN wafers generally come in two forms: GaN on SiC or GaN on sapphire. The former is suitable for power device applications and the latter for light-emitting diodes and other optical applications. Recently, a company claimed to have produced the first true bulk GaN, but no commercial products are available yet. A direct comparison of an experimental GaN PiN and Schottky diodes fabricated on the same GaN wafer showed higher reverse breakdown voltage for the former, but lower forward turn-on voltages for the latter. The fabricated GaN device showed a negative temperature coefficient for reverse breakdown voltage, which is a disadvantage for elevated-temperature operation. Additional disadvantages in GaN compared with SiC power devices include lack of a native oxide layer to produce MOS devices, GaN boules are difficult to grow, thermal conductivity of GaN is only one-fourth that of SiC, and high-voltage bipolar devices are not promising for GaN power devices because of GaN's direct band structure and short carrier lifetimes.

Diamond is intrinsically suited for high-speed, high-power, and high-temperature (up to 1000°C) operation. It is viewed as the ultimate semiconductor. However, diamond faces significant processing hurdles that must be overcome before it can be commercially used for power electronic devices. Diamond advantages include 5 to 10 times higher current density than present devices, high reverse blocking voltage, low conduction losses and fast switching speed, higher-temperature operation and superior heat dissipation, and larger power flow and voltage control devices.

The research group at Vanderbilt University has designed, fabricated, characterized, and analyzed diamond-based Schottky diodes fabricated by plasma-enhanced chemical vapor deposition for high-power electronics applications. A 500-V breakdown voltage device and a 100-A/cm<sup>2</sup> current density device optimized for different applications have been obtained. However, these devices still do not have significant current carrying capability; the highest demonstrated currents have been less than 1 A. Diamond is the ultimate material for power devices in utility applications. However, diamond power devices are not expected to be abundant for another 20–50 years.

## **Supporting Technologies for Power Electronics**

After power devices are built in Si, SiC, or any other material, they have to be packaged so that they can be used in power converters. When these power converters are operated, the heat generated because of the losses in the switches has to be dissipated using a thermal management system. Therefore, packaging and thermal management are two important supporting aspects of power electronics. Chapter 6 discusses the present technology and the research needs for thermal management and packaging of power electronics. The reliability of power electronics is directly related to the ability to keep the devices well within their safe operating level; and generally the cooler that a device can be kept, the less likely it is to fail.

The major source of heat affecting the power electronics is the heat generated by the power semiconductors themselves. These power devices have losses associated with conducting and switching high currents. Typically, a high-power converter would have efficiencies well above 95%. Assuming a 1-MW power converter with 99% efficiency, 10 kW of loss is dissipated as heat. These enormous amounts of losses imply that either more efficient and high-temperature power devices are needed, or effective thermal management systems are required, or some combination of both. Since the present power devices can handle only maximum junction temperatures of 150°C, an appropriate cooling system is needed to be able to dissipate the heat generated by power converters and keep the junction temperatures of power devices well below the limit.

Most of the industry uses old packaging technology. The availability of more reliable cooling systems for much higher power dissipation would require novel cooling technologies. How much the prototype technologies can be scaled up for utility applications has yet to be demonstrated. Areas of R&D in thermal management for utility applications include development of new cooling technologies, coolant materials research, cooling passive components, high-temperature components, thermo-mechanical effects in packaging and converter design, thermoelectric effects, nondestructive diagnostics or process monitoring equipment/sensors, and new packaging materials.

Packaging technology for Si power devices is more or less a mature technology. The main concern is the reliability of packaging at high temperatures. This reliability is more of an issue for packaging SiC-based power devices that can run at much higher junction temperatures of (theoretically) up to 600°C, compared with the 150°C operating temperature of Si power devices.

Based on the analysis of issues relevant to high-temperature packaging, combined with the assessment of on-going R&D activities, four areas have been identified as critical to the further development of packaging technologies for wide bandgap devices for use at high temperatures and high voltages: (1) identification and/or development of alternate materials for use in existing packaging concepts, (2) new concepts for high-temperature package designs, (3) design and development of alternative processes/process parameters for packaging and assembly, and (4) methodologies for high-temperature electrical properties testing and reliability testing.

## **Research Needs for Power Electronics Research & Development**

A summary of prioritized (high, medium, and low) recommendations for R&D in power electronics has been developed based on information collected from researchers, utility representatives and industry experts. DOE should consider R&D in the high-priority areas, noted below, to improve the utilization of power electronics systems and for the cost-effective implementation of DER to improve the reliability of the transmission and distribution system.

### **Applications**

- Reduce the costs of advanced materials needed to increase voltage and current ratings.
- Develop a power electronics test facility that provides a full spectrum of events that a device or system may see over the course of its life.
- Reduce the size of power electronics equipment to create smaller footprints and expand applications in urban areas. Emphasis is needed on thermal management systems and higher voltage and current ratings on semiconductor devices.
- Conduct DER research in the areas of development of low-cost power electronics, development of software tools for dynamic DER capabilities, standardized control and communications, and development of standardized interconnection of single and multiple DER systems.

### **Semiconductor Devices**

- Develop high-voltage, high-current SiC devices for utility applications.
- Develop low-cost SiC IGBT devices to elevate the capabilities of power electronics in utility applications by replacing GTOs.

### **Wide Bandgap Materials**

- Conduct system-level impact studies to evaluate the impact of wide bandgap semiconductors on the utility grid.
- Develop high-temperature packaging to take advantage of the capabilities of SiC devices.
- Develop innovative wide bandgap materials processes to create low cost, defect free wafers.

Additional recommendations for public-private partnerships are suggested in Chapter 7

# 1. INTRODUCTION

## 1.1 What Is Power Electronics?

Generally, **power electronics** is the process of using semiconductor switching devices to control and convert electrical power flow from one form to another to meet a specific need. In other words, power electronics enables the control of the power flow as well as its form (ac or dc and the magnitude of currents and voltages). Figure 1.1 illustrates a block diagram of a power electronic system. The hardware that performs the power processing is called a “converter.” Converters can perform the function of rectifying (ac to dc), inverting (dc to ac), “bucking” or “boosting” (dc to dc), and frequency conversion (ac to ac).

The conversion process requires some essential hardware: a control system, semiconductor switches, passive components (such as capacitors, inductors, and transformers), thermal management systems, packaging, protection devices, dc and ac disconnects, and enclosures. This hardware is referred to collectively as a power conversion system (PCS).

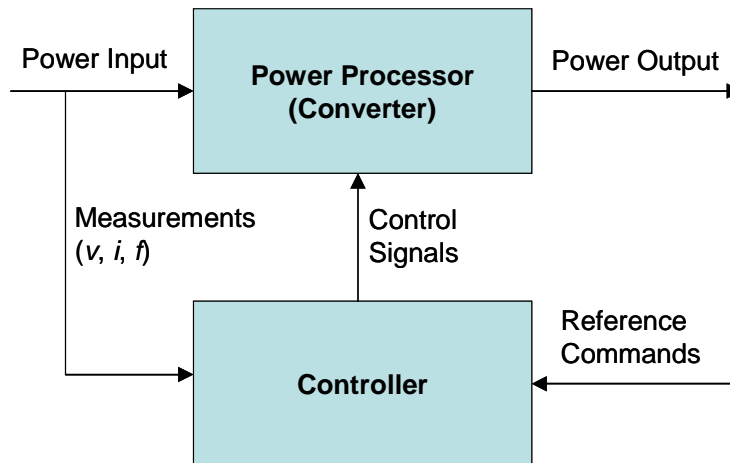


Fig. 1.1. Block diagram of a power electronic system.

## 1.2 What Are the Applications for Power Electronics Devices?

The applications of PCSs are found in many forms within the power system. These range from high-voltage direct current (HVDC) converter stations to the flexible ac transmission system (FACTS) devices that are used to control and regulate ac power grids, to variable-speed drives for motors, interfaces with storage devices of several types, interfacing of distributed energy resources (DER) with the grid, electric drives in transportation systems, fault current-limiting devices, solid-state distribution transformers, and transfer switches.

## 1.3 Power Electronics Today and Tomorrow

Presently, approximately 30% of all electric power generated utilizes power electronics somewhere between the point of generation and its end use. Most power electronics uses today are for improved control of loads such as variable-speed drives for motors that drive fans, pumps, and compressors or in switching power supplies found throughout most consumer products. By 2030, it is expected that perhaps as much as 80% of all electric power will use power electronics somewhere between generation and consumption, with the greatest gains being made in variable-

speed drives for medium-voltage (4.16 to 15 kV) motors, utility applications such as FACTS or high-voltage HVDC converter stations, or in the interface required between utilities and DER such as microturbines, fuel cells, wind, solar cells, or energy storage devices.

Electric power production in the 21<sup>st</sup> century will see dramatic changes in both the physical infrastructure and the control and information architecture. A shift will take place from a relatively few large, concentrated generation centers and the transmission of electricity over mostly a high-voltage ac grid to a more diverse and dispersed generation infrastructure. The advent of high-power electronic modules will continue to encourage the use of more dc transmission and make the prospects for interfacing dc power sources such as fuel cells and photovoltaics more easily achievable.

Figure 1.2 illustrates the required voltage and current rating of power electronic devices for several different application areas. The light blue shading indicates individual power electronics devices that exist at these ratings. Significant improvements in the voltage- and current-handling capabilities and the switching speeds of power semiconductors in the last several years have enabled these devices to be used in more and more applications. However, *the yellow shading in Figure 1.2 indicates that the combined voltage and current ratings exceed those of today's power electronics technology and that several devices must be combined in series or parallel in order to achieve the required application rating for many high- power utility applications.* Also, the switching speeds of the highest-power-rated devices such as thyristors and gate turn-off thristors (GTOs) is limited to 2 kHz. This requires significant filtering requirements, resulting in large custom-built inductors, capacitors, and transformers that can add significant cost to converter installations. It is desirable for high-power electronics to have switching speeds in excess of 20 kHz so that the filtering requirements are much more manageable in terms of size and cost. See Chapter 4 for more discussion of power electronics switch ratings.

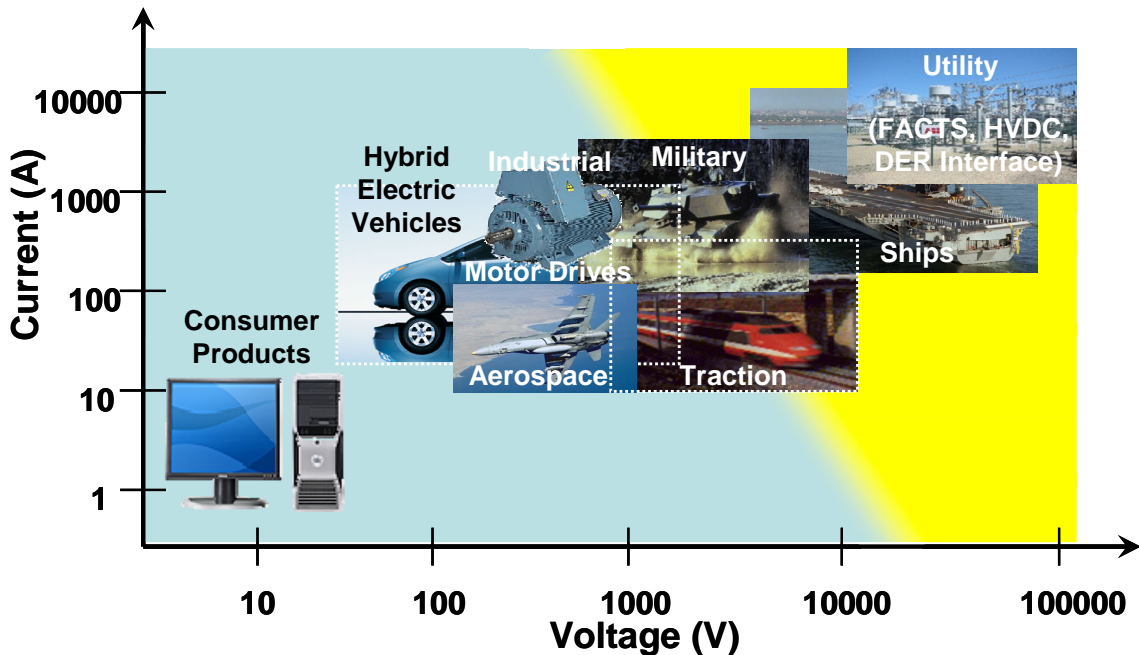


Fig. 1.2. Voltage and current rating for different power electronics application areas.

## 1.4 Power Electronics Benefits to Transmission and Distribution and to Distributed Energy

Power electronics can play a pivotal role in improving the reliability and security of the nation's electric grid. Through the deployment of power electronics, the following benefits can be realized:

- Increased loading and more effective use of transmission corridors
- Added power flow control
- Improved power system stability
- Increased system security
- Increased system reliability
- Added flexibility in siting new generation facilities
- Elimination or deferral of the need for new transmission lines

Although it is very difficult to quantify reliability benefits, there are several reports that attempt to estimate the benefits of deploying advanced technologies, as seen in Fig. 1.3. A recent study\* shows the estimated present value of aggregated attributes of a reliable, modernized grid to be \$638–802 billion over a 20-year horizon with annualized values of between \$51 and 64 billion/year. The study considers eight attributes:

- Cost of delivered energy
- Security
- Reliability or availability
- Safety
- Capacity credits
- Quality
- Environmental
- Quality of life or accessibility

The greatest share of the benefits result from improved reliability (~ 49% of the total) and security (~ 17%). The net impact on the nation's productivity resulting from decreased electricity prices is measured by the increase in the gross domestic product (GDP). It is estimated that a 10% effective reduction in electricity costs would increase GDP by \$23.4 billion for the 2002 GDP base. In order for these benefits to be achieved, applications depend on reliable power electronics technology.

Variable compensation solutions, specifically power electronics-based systems, offer several technical advantages over existing systems, including reliability and improved power quality. Analysts state that while reliability and power quality issues drive the variable compensation market, fixed compensation solutions are still a choice of many customers on account of their low cost and easy maintainability. However, this could change with developments in the semiconductor industry, which are expected to bring down the prices of power electronics-based compensation solutions, while the costs of fixed-compensation equipment are expected to remain at current levels.

Variable-compensation solutions can ensure quality power without voltage and power swings and are expected to be increasingly employed for precision control of system parameters. Further, compensation solutions are a hassle-free, cost-effective alternative to new transmission lines, which, apart from huge investments, require statutory clearances. For example, FACTS technology generally enhances the ability of ac power systems to transmit power in a more controlled manner. The general rule of thumb is that two FACTS (or compensated) lines can transfer the same power as three conventional uncompensated lines. What FACTS buys is greater control and flexibility than conventional compensation.

---

\* *Value of the Power Delivery System of the Future*, EPRI-PEAC.

Source	Type	Log(Benefit)	Benefit (\$ million/yr)
FERC	Congestion - reduced 10%	1.18	15
FERC	Congestion - reduced 10%	1.95	90
Lee et al.	Congestion - reduced 10%	2.00	100
Lee et al.	Congestion - reduced 10%	2.30	200
U.S. DOE	Congestion - reduced 10%	1.20	16
U.S. DOE	Congestion - reduced 10%	1.65	45
EPRI PEAC	Congestion reduction	3.60	4,000
Eyer	Congestion reduction - CA	1.36	23
McConnell	Core Losses & Load Losses	2.08	120
EPRI PEAC	Environmental	2.04	110
Hartikainen et al.	Environmental - EU GHG	2.60	400
EPRI PEAC	GDP	2.11	130
EPRI PEAC	O&M, Capital, Admin Costs	3.00	1,000
Eyer	O&M, Capital, Admin Costs - CA	2.22	165
EPRI PEAC	Power Quality	3.70	5,000
LaCommare and Eto	Power Quality	3.79	6,100
Eyer	Power Quality - CA	2.46	290
EPRI PEAC	Quality of life	3.72	5,200
EPRI PEAC	Reliability/outages	4.49	31,000
Eyer	Reliability/outages - CA	2.15	140
EPRI/Primen	Reliability/outages - reduced 10%	4.08	11,900
LaCommare and Eto	Reliability/outages - reduced 10%	3.38	2,400
EPRI PEAC	Safety	2.95	900
EPRI PEAC	Security	3.82	6,600

**Fig. 1.3. Various cost-benefit studies showing annual savings from increased reliability and reduced transmission congestion.**

## 1.5 Technical Challenges Facing Power Electronics

As previously stated, power electronics play a more and more important role in the utilization of electric power. Consequently, the requirements are also continuously being raised. Some of the important issues that power electronics encounter are as follows:

- *Costs.* Costs of power electronics dominate the total cost of a system. Lower device costs should be the main priority. This requires higher power and faster switching devices. At the same time, it is necessary to improve standardization and modularity of devices in order to reduce the costs of equipment and maintenance.
- *Reliability.* Reliability, including both active and passive components, is an important issue, especially for operations that involve the transmission and distribution (T&D) network.
- *Component Packaging and Thermal Management.* As requirements of applications improve, high-power, high-temperature, and high-speed devices are desirable.



- *Cooling methods.* Advanced cooling methods need to be considered in order to reduce the footprint of power electronics systems.
- *Efficiency.* Efficiency needs to be as high as possible in order to save energy, lower cooling requirements, and improve device performance.
- *Control.* Advanced hardware and control strategies are needed to take full advantage of power electronics.

## 1.6 Role for Government Support

Tremendous advances have been made in power electronics technologies in the last few years, providing new approaches to energy generation and use. However, even as better devices, packaging, and manufacturing processes come along, the potential benefits of power electronics systems have not been attained for reliability, performance, and cost. For example, the PCS hardware costs in many systems will range from 25 to 50% of the total costs. Because of perceived limited markets for PCS applications, manufacturers have been reluctant to expand or scale up the production facilities and invest in improving hardware reliability. If a significant reduction of hardware component costs, improved reliability, multi-use PCS topology, and higher quality components could be achieved via government-led research and development (R&D) or incentive programs, the cycle might be broken; and the benefits of power electronics could be fully realized.

## 1.7 Department of Energy Cross-Cut Areas

Advances in power electronics have been realized through years of R&D within industry. Over the past decade, federal funding has also substantially contributed to the technical progress of high-power electronics systems. Within the U.S. Department of Energy (DOE) portfolio, there are multiple program areas and projects that either involve power electronics or are potentially interested in applying it, such as Energy Storage, Wind, Solar, Transportation, T&D Systems, Superconductivity, Industrial Energy Systems and Combined Heating and Power. While the end applications are different, the underlying PCS components and architecture are similar. Most improvements and technology advances in power electronics for a particular application will also directly or indirectly benefit other application areas. However, these applications have focused on lower power levels with very limited funding to support high power electronics.

## 1.8 Other Agencies Funding Power Electronics

There are several government programs that fund power electronics research. One of the largest funding organizations for high-power electronics is the Defense Advanced Research Projects Agency (DARPA). DARPA's mission is to maintain the technological superiority of the United States by supporting revolutionary, high-payoff research that bridges the gap between fundamental discovery and military applications. As part of its Microsystems Technology Office, DARPA has established the Wide-Bandgap Semiconductor Technology High-Power Electronics (WBG-HPE) program to revolutionize high-power electronics by establishing a new class of solid state power switching transistors employing wide band gap semiconductor materials, such as SiC modules with 15-kV, 110-A, 20-kHz capability. Specific goals include the following:

1. Phase I: demonstration of (a) 75-mm-diameter conducting, low-defect ( $<1.0$  per  $\text{cm}^2$ ) SiC substrates; (b) thick epitaxy (150  $\mu\text{m}$ ) lightly doped layer with  $< 5\%$  variation and low-defect ( $<1.5$  per  $\text{cm}^2$ ), low on-state resistance
2. Phase II (commenced in FY 2004): R&D in device optimization, integrated control,  $>100$  kHz power circuits and packaging and integration. Demonstration of (a) 5-kV and 50-A

- power uni-polar switches; (b) 15-KV and 50-A power bipolar switches; (c) 150-kHz high-power switching and prototype circuits
3. Phase III: demonstrations of (a) an integrated power control, and (b) high-voltage/power packaging with  $>1 \text{ kW/cm}^2$  thermal dissipation capability.

The emergence of high-voltage, high-frequency (HV-HF) devices is expected to revolutionize utility and military power distribution and conversion by extending the use of pulse width modulation (PWM) technology, with its superior efficiency and control capability, to high-voltage applications. Program funding levels for the WBG-HPE program have been approximately \$12–15 million since 2002. DARPA also has a program to develop robust integrated power electronics (RIPE). New semiconductor material systems may enable development of more compact, more efficient, more robust power electronics. The RIPE program intends to pursue R&D of the most promising devices and circuits in these material systems and to explore the integration of those new technologies with other electronics and components to provide significant overall enhancements in power electronics or electronics for harsh environments such as high temperatures. This program started in FY 2004 with funding levels of around \$11 million. This is part of the Materials and Electronics Applied Research that totals almost \$500 million of R&D.

The Air Force Office of Scientific Research funds research in power electronics for use in future military aircraft and directed energy and pulse power weapons. Research includes funding of wide bandgap semiconductor devices in two main areas: power device development (MOSFETs and vertical junction FETs) and applications engineering efforts (e.g., drives, converters). Reliability is an essential factor in the application of military aircraft, but inherent in that is the thermal and packaging aspects of device failure. Most switch module failures are thermally activated or accelerated; thus thermal management and packaging are fundamental to reliability. Aircraft applications demand greater levels of electrical power and at the same time require more power-dense packages with an increase in the rated temperature range. These requirements tend to be extreme, but increasing the ratings for hybrid electric vehicle applications will place stringent requirements on coefficient of thermal expansion matching, metallic and impurity interdiffusion, dielectric standoff integrity, and reliability. Funding levels are around \$3–4 million per year.

The U.S. Navy, through the Office of Naval Research (ONR), is the primary sponsor of the Advanced Electrical Power Systems (AEPS) program, previously known as the Power Electronic Building Blocks (PEBB) program. PEBBs are at the heart of what some in the power electronics community are calling a second electronic revolution—one that will do for power what the microchip did for computers and will bring the advantages of modularization and standardization to power electronics. The PEBB program goals aim to standardize low-cost, affordable components and drive development of commercial mass markets that will sustain PEBB production. Commercialization of PEBBs requires creation of both a supplier base and a user market for intelligent power modules. To reach these goals, a PEBB standard must be created that satisfies both commercial and military users. Therefore, the Navy's goal is to have similar, if not identical, commercial and military requirements. To meet the PEBB affordability goal, there must exist a large commercial market for PEBBs. Hence, an ancillary goal of the PEBB program will be to create commercial-off-the-shelf products that will meet Navy requirements.

The Army Research Laboratory (ARL) has been working on matrix (direct ac-ac converters), switch technologies such as wide bandgap devices, and control algorithm development such as hard switching, soft switching, and hybrid switching methodologies. These technologies will enable future military applications such as hybrid electric vehicles, mobile electric-power generator sets, and robotics, as well as other programs. ARL is pursuing high-temperature inverter demonstrations for bipolar junction transistor, MOSFET, and static induction transistor devices, presently in the 10-kW power level.

The National Science Foundation (NSF) established the Center for Power Electronics Systems (CPES) at Virginia Tech in August 1998. In order to realize the CPES mission, a consortium of five universities has been established with industry partnerships. Each university possesses areas of expertise that combine to form a strong multidisciplinary approach to integrated system programs. The following are the five universities: Virginia Tech, University of Wisconsin–Madison, Rensselaer Polytechnic Institute, North Carolina A&T State University, and University of Puerto Rico–Mayaguez. Much of the research work by CPES focuses on low-power dc-dc converters, motor drives and control, and power electronics semiconductor materials. Funding from industrial partners totals almost \$1 million per year and leverages approximately \$10 million of research in electronics per year.

The National Institute of Standards and Technology (NIST) funds power electronics research through its Semiconductor Electronics Division. Research on power electronics includes developing models for SiC power electronics devices. The goals of the project are to (1) develop electrical and thermal measurement methods and equipment in support of the development and application of advanced power semiconductor devices and (2) develop advanced thermal measurements for characterizing integrated circuits and devices.

The National Aeronautics and Space Administration (NASA) is funding wide bandgap semiconductors for three different applications:

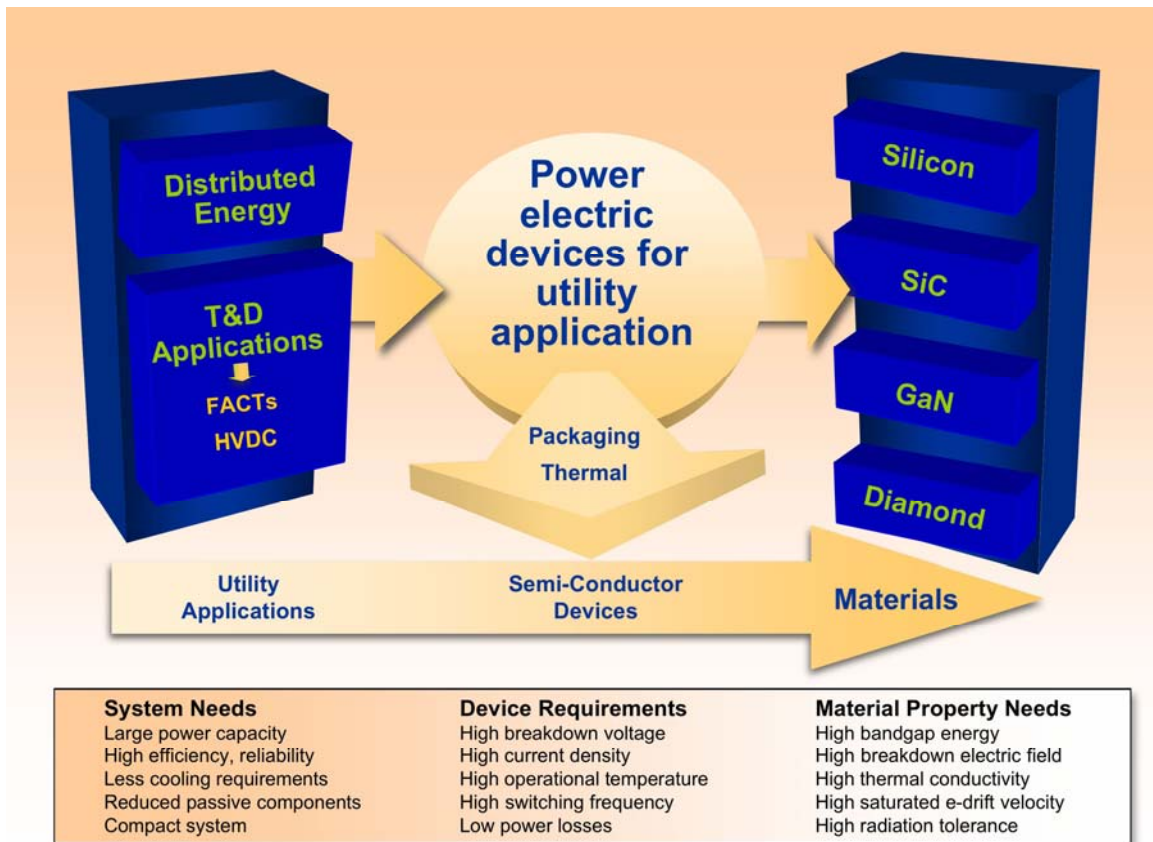
1. Solar system exploration spacecraft—SiC electronics will enable missions in both the inner and outer solar system through significant reductions in spacecraft shielding and heat dissipation hardware.
2. Increased satellite functionality at lower launch cost—Because SiC electronics can operate at much higher temperatures than silicon or GaN, their use could greatly reduce the size and weight of radiators on a spacecraft or even eliminate the need for them. This would enable substantial weight savings on a satellite, or at least allow greater functionality (i.e., more transponders in a communications satellite) by utilizing the space and weight formerly occupied by the thermal management system
3. Advanced launch vehicle sensor and control electronics—SiC electronics and sensors that could function mounted in hot engine and aerosurface areas of advanced launch vehicles would enable weight savings, increased engine performance, and increased reliability.

To support these applications, NASA is focusing on three key areas of high-power electronics—electronic materials, electronics devices, and micro-electronic and mechanical devices. Total funding for all of these areas is about \$3–4 million per year.

The Electric Power Research Institute (EPRI) also identified the benefits of HV-HF semiconductor technology, which include advanced distribution automation using solid-state distribution transformers with significant new functional capabilities and power quality enhancements. In addition, HV-HF power devices are an enabling technology for alternative energy sources and storage systems. EPRI has been collaborating with DARPA on DARPA's WBD-HPE program.

## **1.9 Organization of Report**

This report looks at technical issues across power electronics systems from materials to applications (Fig. 1.4.) and attempts to capture key R&D being performed. This information will be used to provide recommendations on power electronics for utility applications for the Department of Energy's Office of Electricity Delivery and Energy Reliability (OEDER) and Distributed Energy (DE) offices.



**Fig. 1.4. Power electronics systems.**

This report is organized as follows:

Chapter 1 gives an overview of the status of power electronics for utility applications, such as for the interconnection with DE resources, use in HVDCs, or as part of FACTS.

Chapter 2 discusses the state of the art in utility applications of power electronics and what additional needs exist for these devices to be more reliable and cost-effective in FACTS and HVDC applications.

Chapter 3 describes the impact that power electronics have on DE resources and where the greatest needs are for further R&D in this area.

Chapter 4 describes some of the most common power electronics devices and the state of the art in silicon device development.

Chapter 5 has information on wide bandgap semiconductors such as SiC, gallium nitride (GaN), and chemical vapor deposition (CVD) diamond. The advantages that these materials have over today's silicon-based devices are detailed, as well as the challenges involved in fabricating cost-effective devices from these materials.

Chapter 6 describes the thermal management of power electronics and the challenges that exist in maintaining the temperature of these devices within their safe operating area (SOA). This chapter also contains information on the packaging of power electronics and issues involved with the various materials that are needed.

Chapter 7 provides a discussion on where DOE should focus its R&D so that power electronics technology is best utilized for improving the reliability of T&D and for the cost-effective implementation of DE resources.

The appendices at the end of the report provide the following additional information:

Appendix A contains a glossary of some commonly used terms for power electronics devices, packaging, and application.

Appendix B contains information on the different FACTS topologies and a basic description of the purpose of each and how they work.

Appendix C summarizes the capabilities of silicon power semiconductor device capabilities and manufacturers of high-power devices.

Appendix D lists information on SiC power electronics devices.

Appendix E shows the manufacturing process for the various types of materials being considered for power electronics including silicon, SiC, GaN, and diamond.

## 2. UTILITY APPLICATIONS OF POWER ELECTRONICS

High-power electronic devices will play an important role in improving grid reliability, including use in energy storage systems, FACTS applications, distributed energy (DE), and HVDC. This report breaks down the applications into two main sections:

- Transmission and distribution applications of FACTS and HVDC (Chapter 2)
- DE interfaces (Chapter 3)

Because power electronics devices are the building blocks for all applications, Chapters 4 and 5 will focus on their development.

### 2.1 Power System Constraints

The U.S. transmission system continues to incur a growing number of constraints. Growth in electricity demand and new generation, lack of investment in new transmission facilities, and the incomplete transition to fully efficient and competitive wholesale markets have allowed transmission bottlenecks to emerge. Deregulation has enabled power delivery within and between regions and facilitates access to interconnected competitive generation. However, the existing system is not designed for open-access power delivery, creating inefficiencies in power delivery. Additionally, there are few or no market-based incentives for transmission investment, which has contributed to system capacity deficiencies. New transmission line permitting, siting, and construction are difficult, expensive, time-consuming, and typically politically charged, reducing the likelihood that installation of new lines alone will resolve the problem.

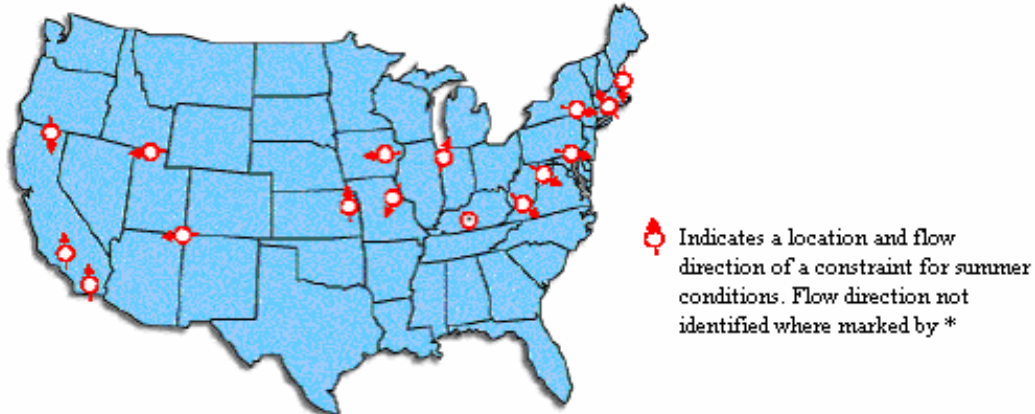
The demands being placed on the transmission system can result in several operating limits being reached, thus creating serious reliability concerns. These characteristics include (terms are defined in the glossary in Appendix A):

- Steady-state power transfer limit
- Contingency limit
- Voltage stability limit
- Dynamic voltage limit
- Transient stability limit
- Power system oscillation damping limit
- Inadvertent loop flow limit
- Thermal limit
- Short-circuit current limit

A recent Federal Energy Regulatory Commission (FERC) study identified 16 major transmission bottlenecks in the United States for 2004 summer flow conditions, as shown in Fig. 2.1 [1]. These bottlenecks cost consumers more than \$1 billion over the past two summers, and it is estimated that \$12.6 billion is needed to fix the identified bottlenecks. Obviously, upgrading and enhancing an aging infrastructure that is not designed to carry out the transactions demanded in today's world will require a great deal of capital investment.

### 2.2 FACTS: Building Tomorrow's Grid Within Today's Footprint

Now, more than ever, advanced technologies are paramount for the reliable and secure operation of power systems. Yet to achieve both operational reliability and financial profitability, it has become clear that more efficient utilization and control of the existing transmission system



**Fig. 2.1. Example of transmission bottlenecks [1].**

infrastructure are required. The challenge facing the power system engineer today is to use existing transmission facilities more effectively. Certainly great difficulty is encountered when seeking permission to construct new transmission lines. Equally certain, the loading required on the system is likely to increase as demand increases. Improved utilization of the existing power system is provided through the application of advanced control technologies. Power electronics–based equipment, or FACTS, can provide technical solutions to address operating challenges being presented today.

A FACTS uses a power electronic–based device for the control of voltages and/or currents in ac transmission systems to enhance controllability and increase power transfer capability. It is an engineered system of advanced power semiconductor-based converters, information and control technologies (software), and interconnecting conventional equipment that builds intelligence into the grid by providing enhanced-power system performance, optimization, and control [2]. Compared with the construction of new transmission lines, FACTS require minimal infrastructure investment, environmental impact, and implementation time. Appendix B contains a description of several different types of FACTS technologies.

### **2.2.1 Comparison of Traditional Solutions and FACTS Solutions**

Traditional solutions to upgrade the electrical transmission system infrastructure have been primarily in the form of new transmission lines, substations, and associated equipment. However, as experiences have proved over the past decade or more, the process to permit, site, and construct new transmission lines has become extremely difficult, expensive, time-consuming, and controversial. FACTS technologies provide advanced solutions as alternatives to new transmission line construction.

The following is a brief summary of the advantages and disadvantages of the different device techniques used to control the voltage or power flow in a T&D system:

#### **Conventional Devices**

- Slow-to-medium response speed (cycles to seconds)
- Limited switching cycles, stepped output
- Less expensive

### Thyristor (line-commutated)–based FACTS

- Fast response speed (cycle)
- Unlimited switching, continuous smooth output
- More expensive

### Voltage Source Converter–based FACTS

- Ultrafast response speed (sub-cycle)
- Unlimited switching, continuous smooth output
- Even more expensive

The development and relationship of conventional and FACTS devices is shown in Fig. 2.2 [3]. Existing mechanical-based technology can handle steady state conditions (normal operations), but under increasing demands placed on the grid, it is more difficult for present technologies to handle dynamic and transient events. Thyristor-switched converters can react to dynamic events (<1 second), while voltage-source converters that incorporate transistors such as insulated-gate bipolar transistors (IGBTs) can react to transient events (<10 msec). This makes these types of converters more valuable to the grid, but generally these converters will cost more than thyristor-based converters.

Figure 2.3 [4] shows how FACTS can increase certain limiting factors in T&D systems so that ultimately only the thermal limit of the conductors limits the power flow in the system. This allows the system to carry more power over existing lines.

Figure 2.4 shows the various types of traditional solutions, conventional FACTS solutions, and advanced FACTS solutions. *Often, traditional system solutions can only partially reduce a transmission bottleneck; thus, other means are required.* Many times the advanced solution will allow the converter to respond to transient conditions and help improve the stability of the system in a way that a conventional FACTS converter cannot; the incremental cost for the additional flexibility and controllability may then be well justified.

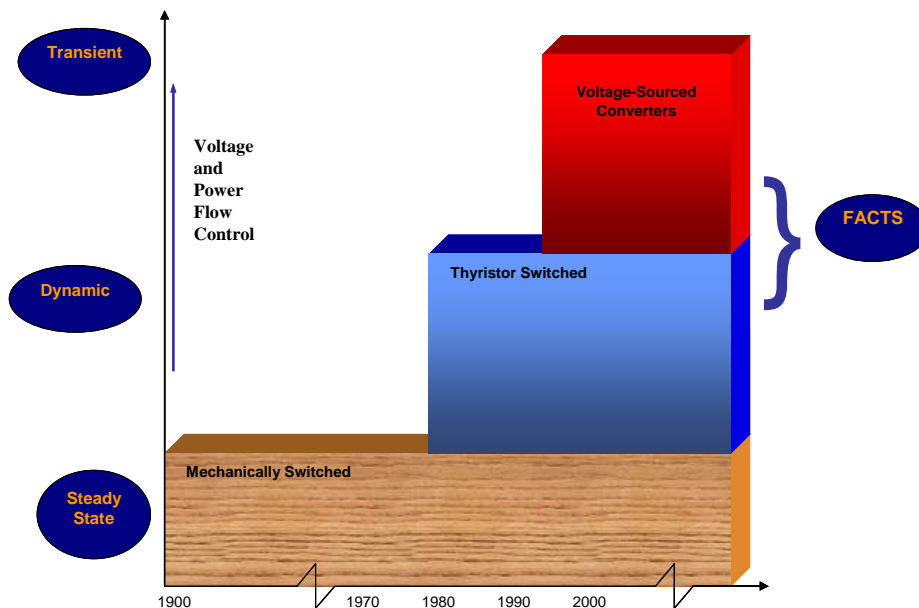


Fig. 2.2. Development and relationship of conventional and FACTS devices [3].



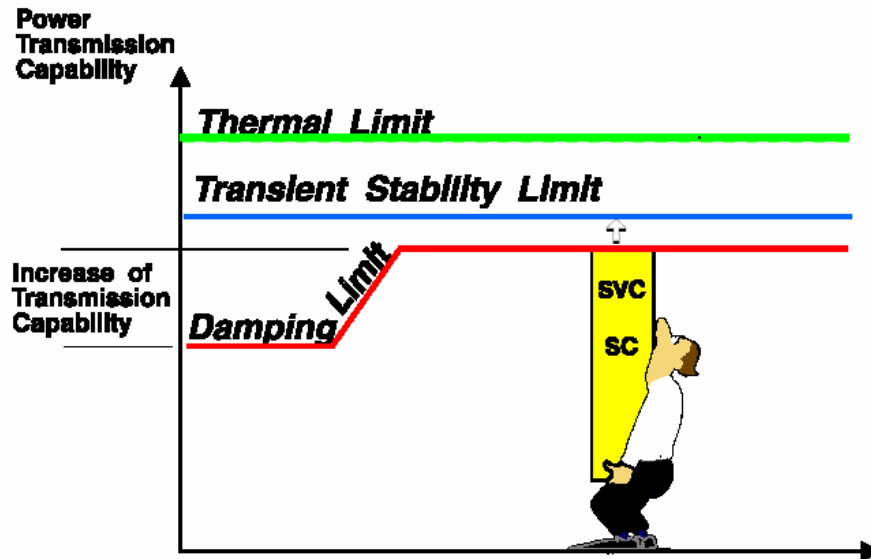


Fig. 2.3. Illustration of how FACTS can increase transmission capability by raising the damping limits and transient stability limits [4].

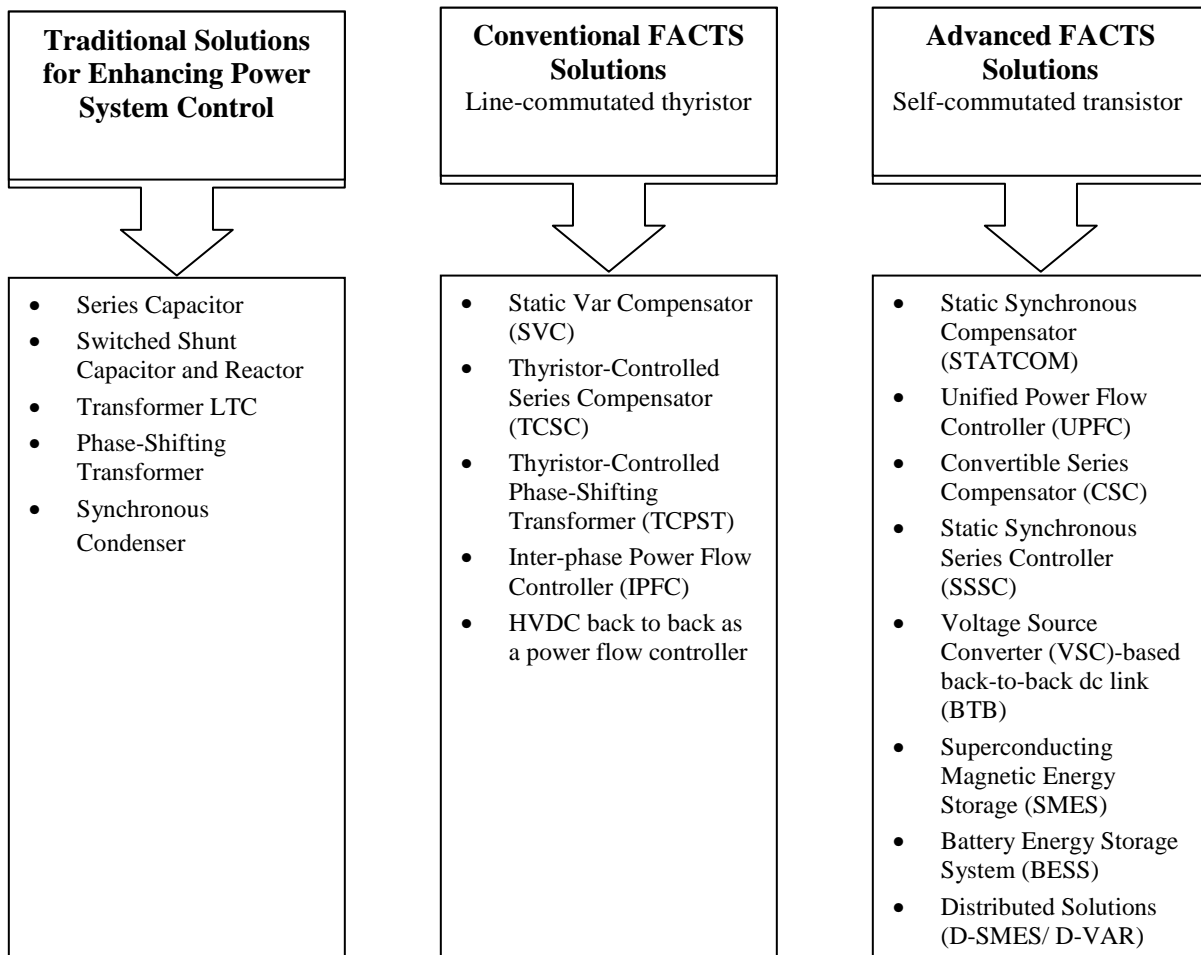


Fig. 2.4. Solutions for enhancing power system control.

## 2.2.2 Limitations and Technical Challenges

While there are benefits to be gained with each of these potential uses for FACTS devices, there are also limitations. In many cases, the use is specific to a certain operating condition. Therefore, the high cost of a FACTS device may not be justified if that is the only purpose for installing the device. Table 2.1 is a summary of potential advantages and disadvantages involved with the use of a FACTS device [5].

**Table 2.1. Advantages and disadvantages of FACTS devices [5]**

Example	Advantages	Disadvantages
Prevention of loop flows	–Easy to stop a given loop flow	–Specific to a given operating condition; may not stop all loop flows
Electronic fence (utility boundary protection)	–Protects property rights –Controls wheeling of power	–Effectiveness limited for highly interconnected utility –May need multiple devices
Increased power transfer capability	–More economical use of generation –Integrates new generation into the system	–May need cooperation of another utility to wheel power
Unloading a selected line	–Adjusts line loading to prevent overload –Unloads a specific line	–Specific to a given operating condition –Unloading another line may not be possible
Directing flow between regions	–Allows a utility to sell power without affecting neighbors	–May result in increased losses

Although application of power electronics is gaining momentum, the revolutionary potential in power systems has yet to be realized. Power electronics-based technologies will not appeal to system planners and operators until they are absolutely certain that this equipment can perform properly and reliably, and other matters such as maintenance, training, and quality management are also covered. It can be easily appreciated that dependability and reliability are of utmost importance for the electric power industry. As of now, only HVDC and static var compensators (SVCs) are considered proven power electronic technologies by system planners [6]. However, even these systems are still expensive.

Two FACTS examples in Tennessee Valley Authority's (TVA) utility grid includes a  $\pm 100$  MVA static synchronous compensator (STATCOM) at Sullivan Substation and  $\pm 12$  MVA D-STATCOM at a 161 kV substation. The  $\pm 100$  MVA STATCOM is a GTO-based inverter built in 1993 by Westinghouse. The purpose for locating the STATCOM at the Sullivan Substation is voltage support. Initial problems with the STATCOM lead to the replacement of diodes, but a chronic problem has been the cooling system. The cooling system is a water-cooled system in which the pumps require replacement every 6 to 8 months. Recent problems with harmonic blockers are caused by pests making their way into them and ultimately shorting the conductors, requiring maintenance. Availability of the STATCOM is estimated to be 50% where 90% is required, thus labeling this STATCOM unreliable. The D-STATCOM is an IGBT-based inverter built by American Superconductors for local voltage control. This system is air-cooled, and TVA has labeled it as very reliable at 98% availability.

Other factors that directly influence the adoption of new power electronics equipment are its economic viability and the environmental impact. Also, the type of control strategy (centralized or decentralized) in a system network influences whether this technology is widely adopted.

The volume of business can also affect the commercial development of power electronic devices by manufacturers. Sizes of the devices, their power-handling capacities, and the characteristics of devices have undergone major changes during the last three decades. For example, the power-handling capability of thyristors used in HVDC applications has increased by a factor of more than 30. Losses in semiconductor devices, which consist of on-state, off-state, and switching losses, also depend on the type of control strategy adopted or the particular transmission system application. An increase in device voltage and current rating, an increase in di/dt capability at turn-on, and a reduced reverse recovery charge can help reduce losses.

### 2.2.3 Investment Costs of FACTS Devices [7]

A major limitation in FACTS device implementation is cost. Figure 2.5 shows the cost breakdown for a typical FACTS installation comparing thyristor-based with converter-based systems. We can see that for a converter-based installation, the cost of the devices makes up as much as 50% of the total installed costs. Because of the benefits from converter-based FACTS, R&D is needed in the reduction of costs of solid state devices such as IGBTs, IGCTs, etc. Driving these costs down will help alleviate the burden of initial capital investment during installation. Chapters 4 and 5 of this report will discuss power semiconductor switches in detail and some of the alternatives, such as wide bandgap semiconductors, for a more reliable switch solution that will yield lower-cost converters compared with today's silicon-based converters.

The investment costs of FACTS devices can be broken down into two categories: (1) the devices' equipment costs and (2) the necessary infrastructure costs.

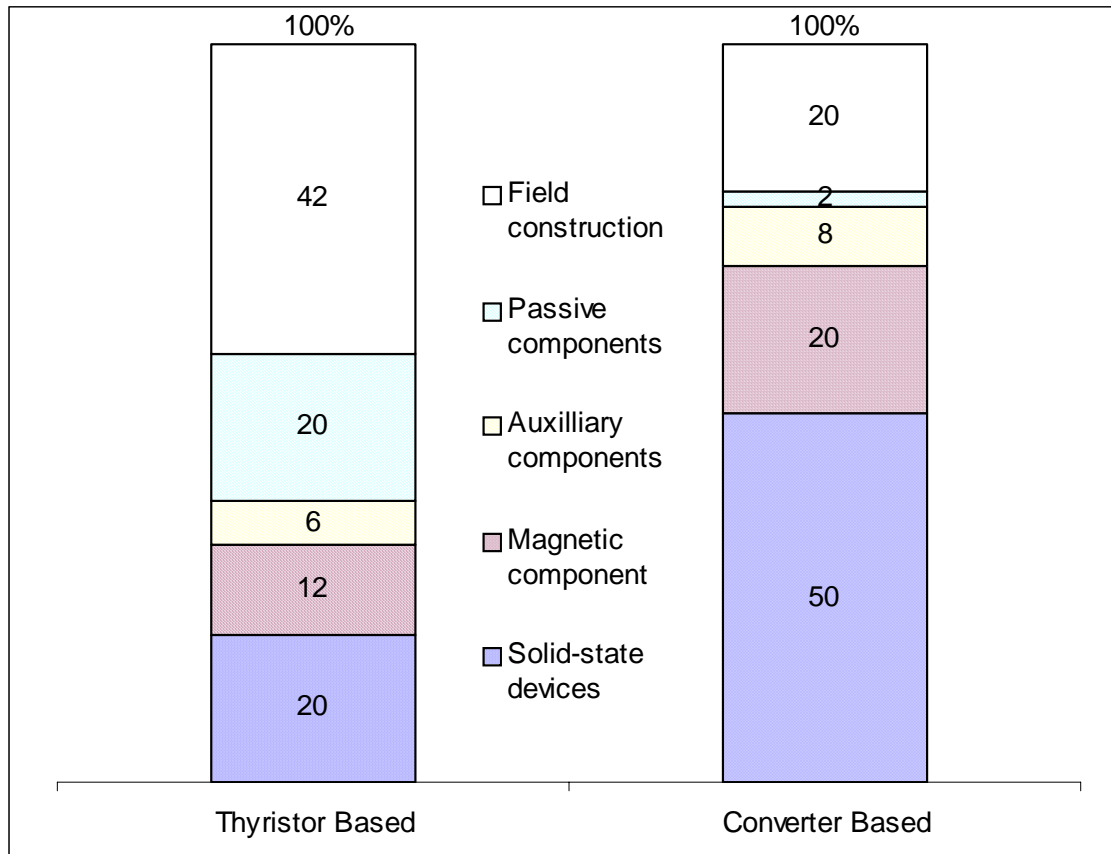


Fig. 2.5. Breakdown of costs for a thyristor-based and a converter-based FACTS installation.

## Equipment Costs

Equipment costs depend not only upon the installation rating but also upon special requirements such as the following:

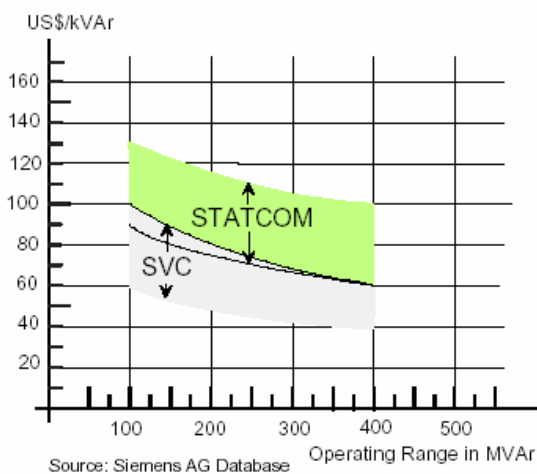
- Redundancy of the control and protection system or even main components such as reactors, capacitors, or transformers
- Seismic conditions
- Ambient conditions (e.g., temperature, pollution level)
- Communication with the substation control system or the regional control center

## Infrastructure Costs

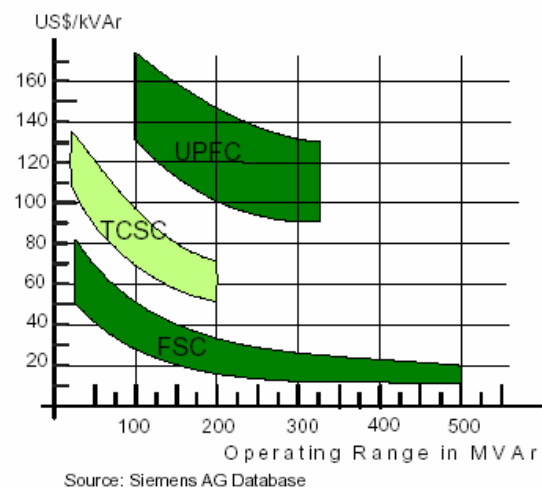
Infrastructure costs depend on the substation location, or in other words, where the FACTS device should be installed. These costs include the following

- Land acquisition, if there is insufficient space in an existing substation
- Modifications in the existing substation (e.g., if new high-voltage (HV) switchgear is required)
- Construction of a building for the indoor equipment (control, protection, thyristor valves, auxiliaries)
- Yard civil works (e.g., grading, drainage, foundations)
- Connection to the existing communication systems

For typical device ratings, the lower limits of the cost, as shown in Figs. 2.6 and 2.7, indicate the equipment costs; and the upper limit indicates the total investment costs, including the infrastructure costs. For very low ratings, costs can be higher; and for very high power ratings, costs can be lower than indicated. The total investment costs shown, which are exclusive of taxes and duties, may vary because of the previously described factors by  $-10\%$  to  $+30\%$ . Including taxes and duties, which differ significantly among different countries, the total investment costs for FACTS devices may vary even more.



**Fig. 2.6.** Typical investment costs for SVC/STATCOM [7].



**Fig. 2.7.** Typical investment cost for series compensation (SC), thyristor-controlled series compensation (TCSC), and UPFC [7].

## 2.2.4 Organizations Performing Research and Development on FACTS Devices

EPRI is one of the few research organizations that is actively doing work in R&D of FACTS devices. Table 2.4 describes seven key FACTS research topics. Figure 2.8 illustrates some EPRI-sponsored FACTS installations in the United States [2]. Several companies are manufacturing devices; many of these installations are going in overseas. Companies that make FACTS and HVDC products are listed in Appendix B.

**Table 2.4. EPRI FACTS research topics**

	Project	Description
1	<b>Intelligent Universal Transformer (IUT)</b>	The IUT is an advanced power-electronic system replacement for conventional distribution transformers, which will provide numerous system operating benefits and added functionality relative to conventional transformers.
2	<b>Increase Transmission Asset Utilization through Application of Power Electronics-Based Controllers</b>	<ul style="list-style-type: none"> <li>• Planning, modeling, and economics of power electronics based controllers</li> <li>• Technology development and field demonstration of power electronics based controllers, innovative concepts, and new power semiconductor switching devices</li> <li>• Diagnostics and operation and maintenance of power electronics-based controllers</li> <li>• Education, information, and knowledge-sharing about power electronics based controllers, in-service installations, installations under development, new concepts, and future research and developments.</li> </ul>
3	<b>Solid State Substation</b>	A solid-state substation would represent a quantum leap forward in substation design. The concept of the solid-state substation effectively draws together a number of parallel developments on discrete solid-state components.
4	<b>Solid State Fault Current Limiter / Circuit Breaker Development</b>	This project is developing a solid-state circuit module that can be operated in series with identical modules to achieve any voltage rating needed. The module will use conventional thyristors combined with a commutating circuit to interrupt the current flow in the main circuit and divert the flow into a path with resistance.
5	<b>Power Electronics-Based Controllers: Developments and Field Demonstrations</b>	<ul style="list-style-type: none"> <li>• Implementation and field demonstration of power electronics-based controllers using emerging power semiconductor switches</li> <li>• Introduction of innovative design concepts</li> <li>• Enhanced versatility, reliability, and functionality of existing power electronics-based controllers</li> </ul>
6	<b>Power Electronics Based Controllers: Computing and Utilization Architectures</b>	The long-term benefits of the project are to create computing and utilization architectures that facilitate effective and efficient planning, modeling, and procurement, and to increase effective utilization and maximization of capital investment through deploying power electronics-based controllers.
7	<b>Power Electronics-Based Controllers: Information and Knowledge Sharing</b>	<ul style="list-style-type: none"> <li>• Holding an annual user group meeting for sharing knowledge and information about field experiences, reliability, availability, lessons learned, and the latest in research and development activities in the area of power electronics-based controllers</li> <li>• Establishing a web site, EPRIFACTS.COM, accessible for on-time information</li> <li>• Developing a reference handbook on power electronics-based controllers</li> </ul>

## 2.3 High-Voltage Direct Current Transmission Systems

Another utility application area of power electronics is in the converter stations for HVDC transmission systems. This was the first application of power electronics in power transmission.

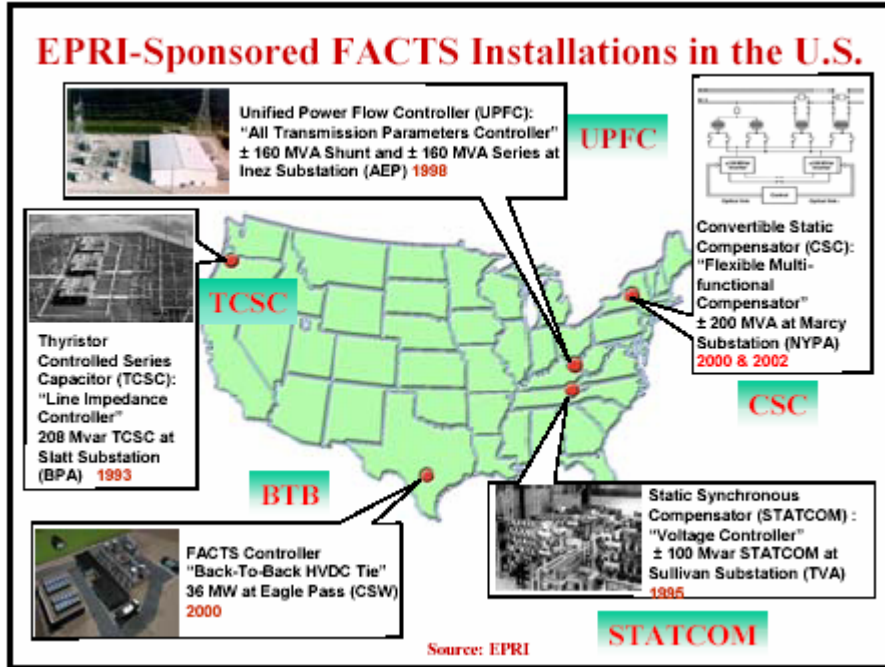


Fig. 2.8. EPRI-sponsored FACTS installations in the United States [2].

Almost 55 GW of HVDC transmission capacity has been installed worldwide, as seen in Fig. 2.9 [8].

HVDC technology is used to transmit electricity over long distances by overhead transmission lines or submarine cables. It is also used to interconnect separate power systems where traditional ac cannot be used. Typically, an HVDC transmission has a rated power of more than 100 MW, and many are in the 1000- to 3000-MW range.

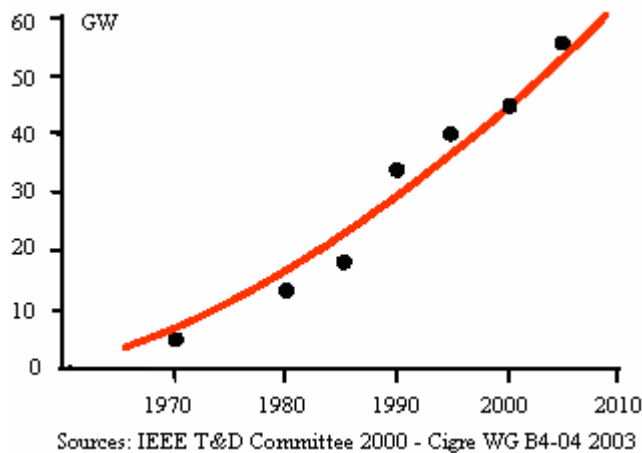


Fig. 2.9. Worldwide installed capacity of HVDC links [9].

### 2.3.1 High-Voltage Direct-Current History [9]

The development of HVDC technology started in the late 1920s, and only after some 25 years of extensive development and pioneering work was the first commercially operating scheme commissioned in 1954. This was a link between the Swedish mainland and the island of Gotland in the Baltic Sea. The power rating was 20 MW, and the transmission voltage 100 kV. At that time, mercury arc valves were used for the conversion between ac and dc, and the control equipment used vacuum tubes.

A significant improvement of the HVDC technology came around 1970 when power electronic-based valves using thyristors were introduced in place of the mercury arc valves. This reduced the size and complexity of HVDC converter stations substantially.

In 1995 ASEA Brown Bover (ABB) announced a new generation of HVDC converter stations, HVDC 2000, that further improves the performance of HVDC transmissions; and in 1997, a new dc cable technology built upon an IGBT-based voltage-source converter (VSC) called HVDC Light was introduced by ABB.

HVDC Light uses new cable and converter technologies (transistors instead of thyristors) and is more economical at lower power levels than traditional HVDC. It is particularly suitable for small-scale power generation/transmission applications and extends the economical power range of HVDC transmission down to just a few tens of megawatts. Recently Siemens has also offered the HVDC Plus technology, its counterpart to ABB's HVDC Light technology.

### 2.3.2 Three Different Categories of High-Voltage Direct Current Transmissions [9]

#### 1. Point-to-Point Transmission

Point-to-point transmission is the main category of HVDC transmission, and it can be divided into two different types of transmission, depending on the number of cables and converters needed. Monopolar HVDC is shown in Fig. 2.10. It consists of the following:

- One high-voltage line for dc current transmission
- Return path is via earth ground or a low-voltage conductor (option)
- Rating of up to 1500 MW

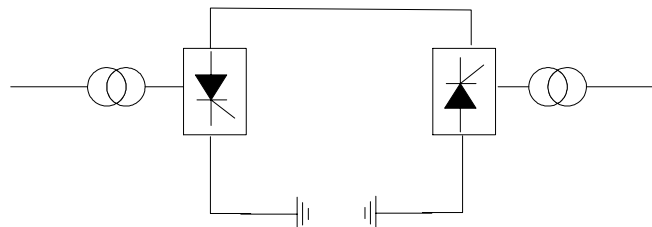


Fig. 2.10. Monopolar HVDC [9].

Bipolar HVDC is shown in Fig. 2.11. It consists of the following:

- Two dc lines with  $\pm$  dc voltage level for transmission
- Rating up to 3000 MW

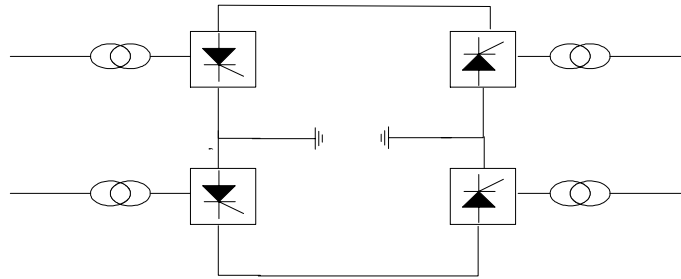


Fig. 2.11. Bipolar HVDC [9].

## 2. Back-to-Back Station

An HVDC back-to-back station is normally used to create an asynchronous interconnection between two ac networks, which could have the same or different frequencies. In these installations, both the rectifier and the inverter are located in the same station. These can be used to interconnect two different systems that have the same frequency but are not synchronized (U.S. Eastern Interconnect and U.S. Western Interconnect; see Fig. 2.12) or can be used to interconnect systems of different frequencies (50 Hz, 60 Hz), as in Japan or in South America.

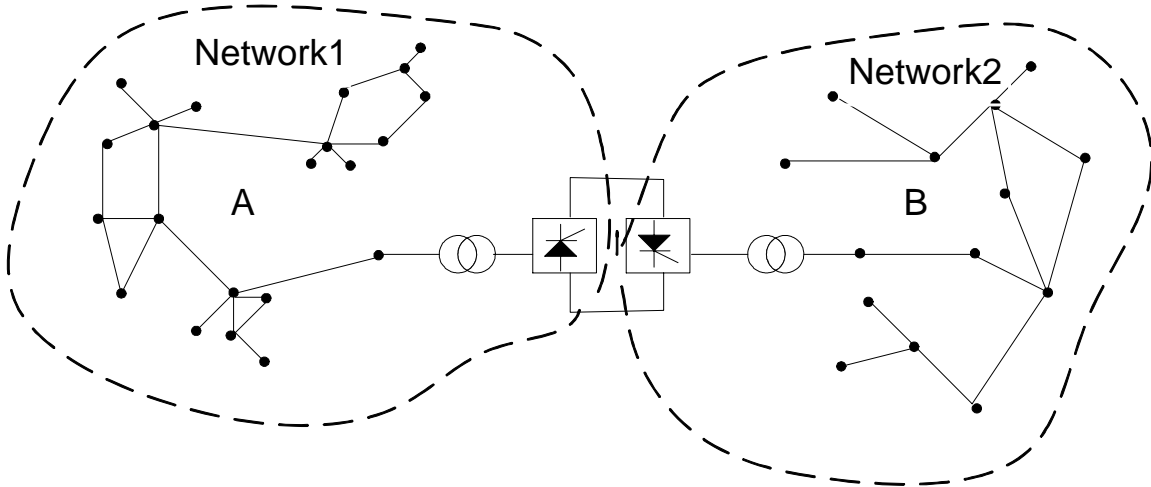


Fig. 2.12. Back-to-back HVDC [9].

## 3. Multi-Terminal System

A multi-terminal HVDC transmission is an HVDC system with more than two converter stations, as shown in Fig. 2.13. A multi-terminal HVDC transmission is more complex than an ordinary point-to-point transmission. In particular, the control system is more elaborate, and the telecommunication requirements between the stations become larger. There is only one large-scale multi-terminal HVDC system in operation in the world today. It is the 2000-MW Hydro Quebec–New England transmission built by ABB between 1987 and 1992.



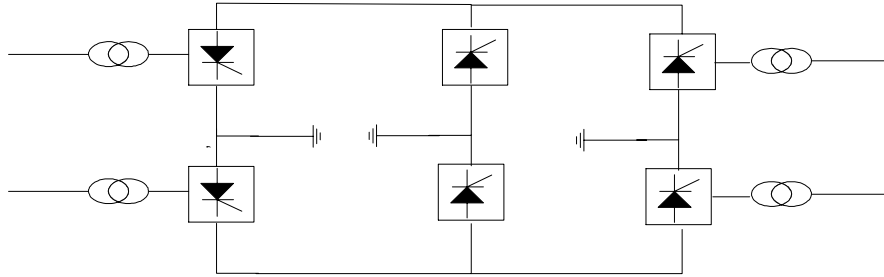


Fig. 2.13. Multiterminal HVDC [10].

### 2.3.3 Advantages of High-Voltage Direct Current for System Interconnection [8]

Figure 2.14 [10] shows the existing HVDC lines in North America. The easiest way to interconnect large power systems, which are already heavily loaded, is to use HVDC. The major benefit of an HVDC link is its ability to control the power flow and its flexibility to adapt to different ac system characteristics at both sides of the interconnection. In this respect, HVDC offers significant benefits for the system interconnection. These benefits are listed as follows. They are generally valid and do not depend on the size of the interconnected systems.

- With a dc solution, interconnection rating is determined only by the real demand of transmission capacity. With an ac solution, for system stability reasons, the ac rating must be higher than the real demand on power exchange.

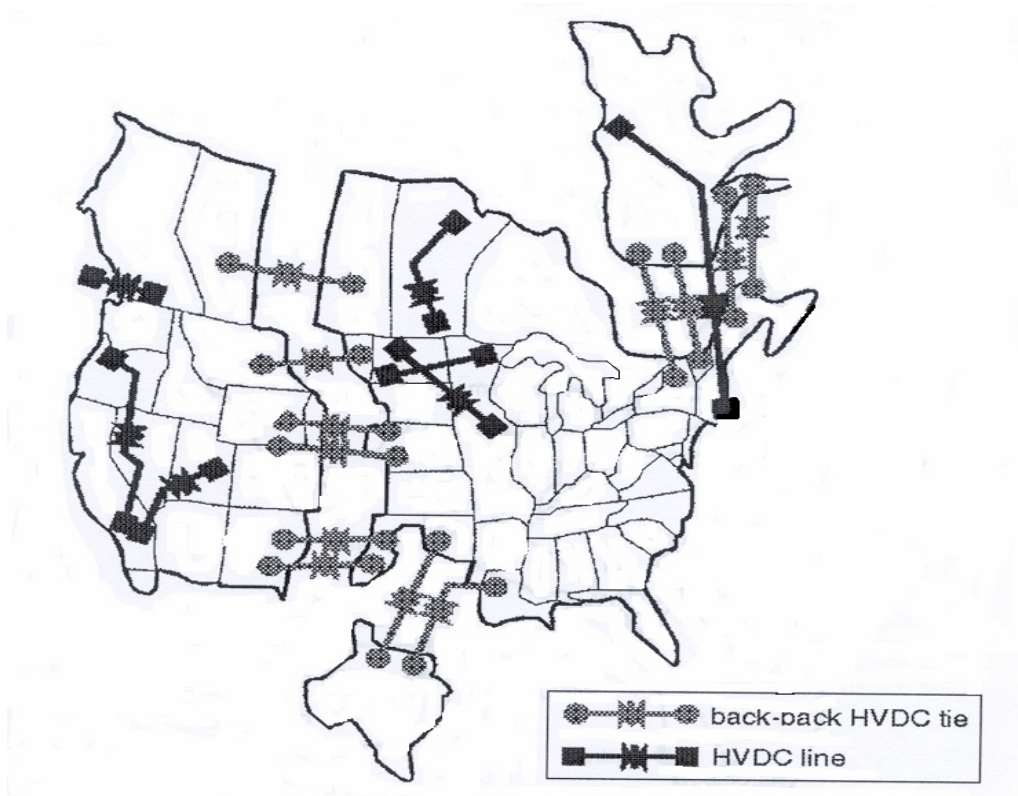


Fig. 2.14. HVDC lines in North America [10].

- Increase of power transfer; with dc, staging is easily possible.
- With dc, the power exchange can be determined exactly by the system operator.
- dc features voltage control and power oscillation damping.
- dc is a barrier against stability problems and voltage collapse. Transmission distance is determined by voltage drop and almost irrelevant to line charging and line inductance.
- Efficient use of conductors, because ac lines utilize the peak voltage only partially while dc lines can always utilize the peak voltage.
- dc is a barrier against cascading blackouts.
- Lower investment cost.
- Long-distance water crossing.
- Lower losses.
- Asynchronous connection.
- Limit short circuit currents.
- Environment.

The limitations of HVDC include

- Cost, which typically requires long lines to compensate for cost of the converter stations.
- Reliability, because of the many ancillary components required for normal operation, such as thermal management systems, active filters, and the PE.

## **2.4 FACTS and HVDC Systems Benefits Summary [2, 7]**

FACTS and HVDC can provide strategic solutions to upgrade the nation's electrical transmission system infrastructure by the following means:

- Increasing capacity—By increasing the damping limit and transient stability limit so that the power transmission capability is close to its thermal limit.
- Enhancing reliability—Transmission system reliability is affected by many different factors. Although FACTS devices cannot prevent faults, they can mitigate the effects of faults and make electricity supply more secure by reducing the number of line trips.
- Improving controllability—They can control the flow of power and the regulation of voltages in the power grid.
- Preserving the environment—FACTS devices are environmentally friendly. They contain no hazardous materials and produce no waste or pollutant.
- Value: saving time and money, and enabling profitability—FACTS help distribute electrical energy more economically through better utilization of existing installations, thereby reducing the need for additional transmission lines.

These power electronic technologies allow a more efficient use/expansion of grid assets by the following means:

- Increasing the real power capacity of existing systems: up to 40% increase in capacity can be realized.
- Integrating intelligence-based control of networks.
- Providing dynamic response to system contingencies: FACTS solutions can respond much faster than the conventional solutions such as mechanical switch, so they are needed to respond to fast-changing network conditions.

- Facilitating non-synchronous grid interconnections: HVDC can connect two grids with different frequencies.
- Enhancing necessary grid expansion where required—reducing transmission line construction: Frequently, adding new transmission lines to meet increasing electricity demand is limited by economical and environmental constraints. FACTS and HVDC lines help to meet these requirements with the existing transmission systems.
- Changing the “laws of physics” on the power system: Power naturally flows from high impedance to low, but FACTS devices help to control the power flow under the operator’s consideration.
- Directing power delivery for maximum operating efficiency, increased dynamic and transient grid stability, and reduction of loop flows.

#### **2.4.1 Future Developments in FACTS**

For widespread adoption of semiconductor devices to occur, further advances must be achieved. These advancements are described as follows.

- Lower cost of semiconductor devices
  - Increase power ratings and speed of semiconductor switches
  - Reduce the footprint through the use of high-energy density systems
- A sound pricing policy for reactive power
- Improved reliability of active and passive components, including balance of plant components
- Development of advanced control systems for multiple converters
- Reduction of harmonics and electromagnetic interference
- Development of test-bed for power electronics components

#### **Lower-cost semiconductor devices**

The cost of FACTS devices has been a major hurdle for commercialization in the United States. For example, the cost of an SVC is twice that of a capacitor bank with the same rating, and the cost of a STATCOM is three times that of traditional technologies. Utilities are waiting for the reduction of the costs of FACTS devices. A standard design rather than a custom design is a good way to reduce the cost. By developing high-power and faster switching devices, the number of components can be reduced, thereby reducing overall system costs, without compromise on the overall performance and reliability (or while keeping the overall performance and reliability still acceptable).

Another approach to reduce costs is to combine optimal characteristics of components. Future developments will include the combination of existing devices, for example, combining a STATCOM with a thyristor-switched capacitor (TSC) to extend the operational range and combine the best features of each. In addition, more sophisticated control systems will improve the operation of FACTS devices.

Reducing the real-estate footprint can increase the market potential for installing systems in urban areas that may have space constraints. A smaller footprint will require advanced thermal management systems along with improvements in semiconductor technologies (e.g., higher current-carrying capability, higher blocking voltages). High-temperature packaging of these devices will also be necessary.

Research work should include a FACTS building block. One of the reasons that FACTS installations are expensive is that each one requires custom engineering, design, and installation. The costs for these installations would be less if standard design and equipment could be used. If a FACTS installation could be composed of “standard” and reliable FACTS building blocks, this might lead to more widespread acceptance by utilities and lower total installed cost.

### **Sound reactive power pricing policy**

Another obstacle blocking the use of FACTS devices is the lack of a reactive power pricing policy. One FACTS device can benefit the whole power system in a certain area, not only for a particular utility, but also for its neighbors. Who should pay for this FACTS device becomes an intriguing question with much to debate. As a result, only after we have a sound pricing policy will utilities or customers use FACTS devices without hesitation.

### **Superconductor technology**

Developments in superconductor technology open the door to new devices like a superconducting current limiter and superconducting magnetic energy storage. There is a vision for a reliable and efficient high-voltage transmission system to generate electrical energy in an economical and environmentally friendly manner and provide electrical energy where it is needed. FACTS are the key to making this vision live [7].

### **Harmonics and EMI considerations**

The main drawback of SVCs is the generation of harmonics. Their highly nonlinear characteristics make them absorb a non-linear current, which injects harmonic currents into the grid. This phenomenon is a common characteristic of most of the power electronic compensators. In the SVC case, the amount of harmonics injected into the line depends on the firing angle [11]. The main drawbacks of thyristor-controlled series are also the nonlinear effects on system stability, discrete (non-continuous) impedance, and harmonics injection. It is known that harmonic currents and the resulting harmonic voltages can be magnified considerably, causing all sorts of operational problems, especially if a resonance occurs at one of the harmonic frequencies [12]. Development of switching strategies that minimize harmonics, or different converter topologies such as multilevel converters that minimize the generation of harmonics, is needed. In addition, the ability to switch at higher switching frequencies would enable harmonics to be more easily filtered out with smaller capacitors and/or inductors.

### **Evaluation needs**

The demonstration phase of advanced technologies is typically a cautious attempt by the utility industry to operate in a field environment, but it can be quite expensive and of little value if the technology is not fully evaluated because it is operated in a low-impact location or not placed into full service. Since many demonstrations do not provide a full spectrum of events that a device or system might see over the course of its life, the needed credibility of the technology may require many expensive demonstrations and years of field testing to gain the utility industry's confidence. Thus, the expensive and lengthy technology demonstrations must be resolved by providing a full-power (high-voltage and high-current) testing environment that can fully test and evaluate a range of early prototypes to near-commercial transmission technologies. This process would both reduce the lead time to implementation and reduce the cost and duration of demonstration projects that would follow. In addition, utilities would be more willing to implement a new technology that has been proven in an extreme test environment.

### **2.4.2 Future Developments in High-Voltage Direct Current [13]**

HVDC is known for its high-power capability, excellent stability performance, flexible control, and regulation. However, at present, disadvantages like low reliability in the initial phase of operation, complicated control, high requirements for operators, and the risk of inducing sub-synchronous resonance of large turbo-generators plus harmonics pollution, etc., are problems to be solved. Some particular issues that need further research and simulation tests include the following.

- When several HVDC circuits send power to receiving terminals close to each other, a fault on the ac system could create simultaneous outages of the dc system. Research is needed to ensure reliability of the bulk power system.
- Research is needed to exploit the modulation capability of the dc systems to strengthen the ac/dc hybrid system.
- Equipment reliability needs to be enhanced and the design of the converter station and the HVDC lines improved.
- For the network interconnection with other networks, a back-to-back HVDC scheme may have advantages from system operation and economic points of view. Research should also be undertaken on this aspect.
- It should be determined whether different circuit topologies such as the multilevel converter allow a more inexpensive or more reliable interface to be developed for HVDC converter stations.

## 2.5 Multilevel Inverter

Multilevel inverter structures have been developed to overcome shortcomings in solid-state switching device ratings so that they can be applied to high-voltage electrical systems. The multilevel voltage source inverters' unique structure allows them to reach high voltages with low harmonics and without the use of transformers. This makes these unique power electronics topologies suitable for FACTS and HVDC stations. The use of a multilevel converter to control the frequency, voltage output (including phase angle), and real and reactive power flow at a dc/ac interface provides significant opportunities in the control of distributed power systems [14].

Multilevel inverters can be used to interface lower-voltage dc energy storage or source devices with the grid. They consist of power modules that are stacked together to produce required high utility level voltages. One of the most versatile topologies is the cascade multilevel inverter, shown in Fig. 2.15 (a). This topology eliminates the need for single high-voltage power switches and diodes that do not exist in the utility voltage levels. They also eliminate the need for connecting lower-voltage power devices and switches in series and parallel, reducing the problems and extra circuitry associated with current and voltage sharing.

The advent of high-power electronic modules has also encouraged the use of more dc transmission and made the prospects for interfacing dc power sources such as fuel cells and photovoltaics more easily attainable. A modular, scalable power electronics technology that is ideal for interfacing these types of DER with the utility is the transformerless multilevel converter [15]. Some of the advantages of multilevel inverters include the following:

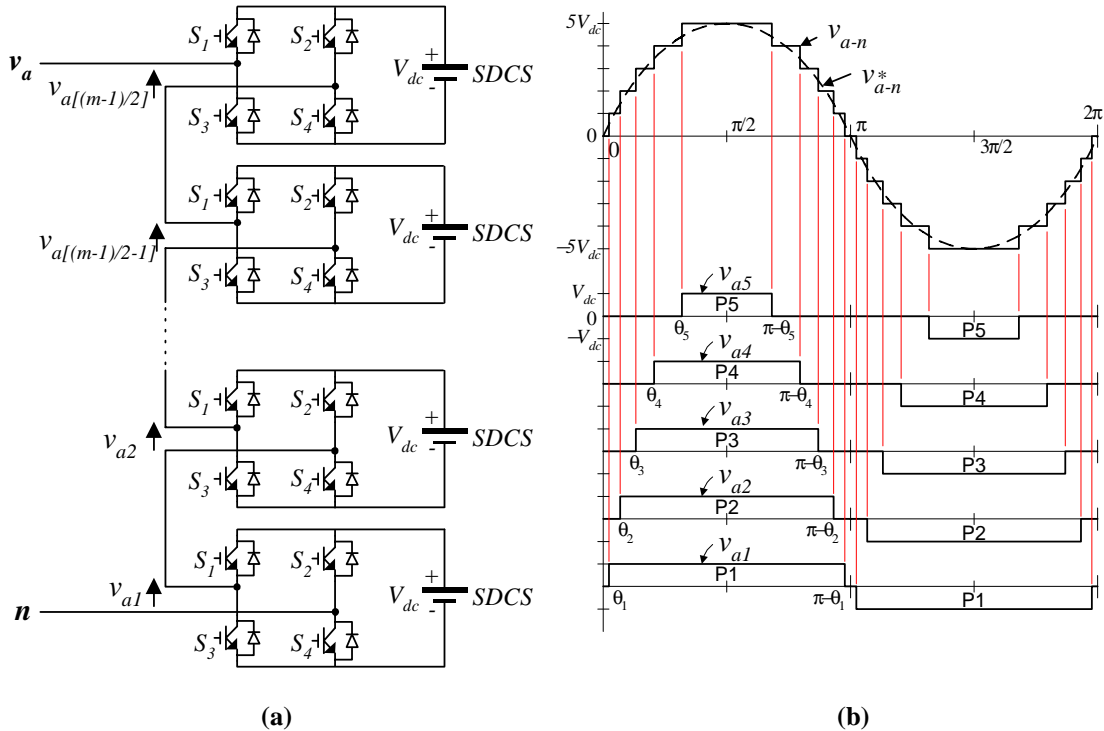
- They are modular, so lower manufacturing costs are expected. Among many types of multilevel inverters, the cascaded multilevel inverter is more modular.
- Redundant levels can be added for increased reliability. When one power module or one energy storage device fails, the other levels, the remaining power modules and energy storage devices can sustain the output voltage.
- Each phase is built separately from the others; therefore, the final converter can be easily connected to be single-phase, multi-phase, or three-phase wye or delta as required.
- Fundamental frequency switching techniques can be applied to decrease the switching losses and to increase the converter efficiency.

One disadvantage is the greater number of power semiconductor switches needed in a multilevel converter. Although the lower-voltage-rated switches can be utilized in a multilevel converter, each supplement switch requires a related gate drive circuit. This increases the

complexity of the system, but if designed properly, the extra devices can yield redundancy in the converter that can allow it to run even with the failure of a power module.

The multilevel converter topology shown in Fig. 2.15(a) incorporates cascaded single-phase H-bridges with separate dc sources (SDCSs). This requirement makes renewable energy for the isolated dc voltage sources needed for the cascade inverter. Each SDCS is connected to a single-phase full-bridge, or H-bridge, inverter. Each inverter level can generate three different voltage outputs,  $+V_{dc}$ ,  $0$ , and  $-V_{dc}$  by connecting the dc sources to the ac output by different combinations of the four switches,  $S_1$ ,  $S_2$ ,  $S_3$ , and  $S_4$  [14]. To obtain  $+V_{dc}$ , switches  $S_1$  and  $S_4$  are turned on.

The ac outputs of each different H-bridge inverter levels are connected in series so that the synthesized voltage waveform is the sum of the inverter outputs. The number of output phase voltage levels  $m$  in a cascade inverter is defined as  $m = 2s + 1$ , where  $s$  is the number of separate dc sources. An example phase voltage for an 11-level cascaded H-bridge inverter with 5 SDCSs and 5 full-bridges is shown in Fig. 2.15(b) [14]. The phase voltage  $v_{an} = v_{a1} + v_{a2} + v_{a3} + v_{a4} + v_{a5}$ .



**Fig. 2.15** Single-phase structure of a multilevel cascaded H-bridge inverter (a). Circuit diagram (b) Waveforms and switching method of the 11-level cascade inverter [14].

### 3. POWER ELECTRONICS INTERFACE FOR DISTRIBUTED ENERGY SYSTEMS

Distributed generation (DG) applications today are primarily for niche markets where additional power quality is desired or local onsite generation is desired. In some cases, the distributed energy resource (DER) is designated for backup and peak power shaving conditions. Frequently, these generators are in an inoperative state for long periods until the needs of the load or the local utility require additional generation. Thus, DG can be costly to install, maintain, and operate for most commercial customers. There are several contributing factors to high costs, including the high cost of natural gas, lack of a standard installation process, additional overcurrent and overvoltage protection hardware required by the utility, and the capital cost of many of the new technologies such as microturbines, which is double the cost of conventional diesel power gensets. DE is cost-effective in some niche markets where the electricity cost is extremely high, such as Hawaii and the Northeast, or where outage costs are costly. Two directions for achieving cost-effectiveness for DER are reducing the capital and installation costs of the systems and taking advantage of additional ancillary services that DE is capable of providing. A market for unbundled services (ancillary services) would promote installations of DG where costs could not be justified based purely on real power generation.

Power electronics currently are used to interface certain DER such as fuel cells, solar cells, and microturbines to the electric power grid to convert high-frequency ac or dc voltage supplied by the DE source to the required 60-Hz ac voltage of the grid [1, 2]. However, power electronics also offer significant potential to improve the local voltage regulation of the grid that will benefit both the utility and the customer-owned DE source. Basically, power electronics for DER are in their infancy. Power electronics offer the conversion of real power to match the system voltage and frequency, but this interface could do much more. For example, the power electronics could be designed to produce reactive power by varying the phase shift in the voltage and current waveforms from the power electronics. Also, various controls could be built into the power electronics so the DE can respond to special events or coordinate its operation with other DE sources on the distribution system.

The goal ultimately is to achieve a “plug and play” connection of DER with the electric power grid. Some of the objectives are

1. “Good citizen” operation: DER do not impact other devices or loads on the electric grid in a negative way—they only help the grid.
2. Fault contribution suppression: Fast power electronics can respond to fault events on the electric grid and shut down the power feed from the DER.
3. Standard connection scheme: Standardization of power electronics interfaces offers the ability to standardize the connection of DER.
4. Smart controls: The combination of controls with the power electronics offers the ability to optimize local control of DER as well as achieve ancillary services for the grid, such as voltage support.
5. Event response: The combination of communications with the controls and power electronics could enable DER to be responsive to the needs of the power grid. The DER could pick up additional load to reduce power capacity demands or could inject power into the grid to offset generation and transmission shortfalls.

Several economic and technical challenges for power electronics are discussed in this section.

### **3.1 Technical Challenges**

A number of technical challenges exist for power electronics. First, present designs of inverters for DER devices such as microturbines are incapable of supplying sufficient current to start motors. Some combination of energy storage technologies such as ultracapacitors needs to be built into the power electronics to satisfy this requirement.

A significant unknown is the interaction of multiple DER systems connected to the power grid, especially when these systems have smart power electronic controls. They may have the tendency to “fight” each other rather than work in a coordinated fashion. For example, a voltage sag may engage multiple DE sources to inject reactive power to boost the local voltage. However, they may end up boosting the voltage too high and then respond by backing off the reactive power injection too much. The cycle could continue if the DE controls are staggered in some fashion.

The impact of synchronous machine–based DER systems on the protection coordination of distribution systems has been a concern for a number of years. Basically, a low penetration of DER systems has a low impact on protection coordination. However, as the total installed capacity of DER systems reaches a significant portion (10% or more) of the distribution system or distribution circuit capacity, then protection coordination could be a concern. On the other hand, power electronics–based DER systems are current-limited, usually to approximately 200% of their rated output; so the impact on protection coordination is of less concern. Thus power electronics–based DER systems offer a greater potential for multiple installations on a given distribution feeder without impacting existing protection hardware and schemes in place by the utility. However, utilities would likely require a demonstration that such a scheme works before they would allow DER to connect to their systems.

### **3.2 Distribution System Design**

Most distribution systems are designed to provide power radially (in one direction) from the substation to the loads via distribution feeders or circuits. Consequently, conductor sizes get smaller as the power flow gets closer to the load. The combination of (1) smaller conductors, which have higher impedances, nearer the load, (2) the fact that protection coordination is tailored to prevent fault current contribution from the substation (one source), and (3) the fact that the utility circuit breakers are near their fault current limits complicates the integration of DE into the electrical network. Power electronics offer the potential to transition existing distribution systems to accommodate DE by enabling fast switching to prevent fault current contribution and to respond to abnormal events. In the long run, a new distribution system design that incorporates the features of the transmission system and networks would be better for the integration of DE [3].

### **3.3 Present Standards**

The present standards (IEEE 1547) are focused on making DE a second-class citizen compared with the utility system. Standard 1547 requires that DE remove itself from the electrical network whenever the system is in stress and a possibility of an islanding situation exists (DE continuing to operate and supply power to a separated part of the network). By disconnecting the DER, however, the local grid loses the voltage support and frequency regulation capabilities of the DER. More research is needed to determine how DER can help the grid, rather than focusing entirely on determining whether existing DER technology meets IEEE 1547.



### 3.4 Economic Challenges

The cost of power electronics is a significant portion of a DER system, up to one-third of the total installed cost. The main objective of manufacturers is to reduce cost while maintaining functionality and reliability [4]. Markets for ancillary services and cheaper packaging for power electronic systems must be developed to lower system costs. Most DER systems are too expensive to achieve a short-term payback; they are not purchased to provide cheaper power than the electric grid, because they usually do not. DER systems usually are purchased to achieve high power quality or to take advantage of combined cooling, heating, and power. DER systems are being applied in many niche applications, such as producing power from flare gas, which also reduces emissions that would occur if the flare gas were vented to the atmosphere.

DE is gaining ground in the area of power quality improvement. Increasingly, digital loads that demand high power quality are showing up on the electrical network. A momentary outage of a few cycles that used to be of no concern can now be disastrous to digital loads such as semiconductor plants. The outage costs alone can range from thousands to millions of dollars; thus outage avoidance can make it cost-effective to install onsite generation at the load.

Unfortunately, most DE systems are not designed for uninterruptible power supply operation. The integration of power electronics, DE, and energy storage could ultimately be the answer for power quality. However, this integration will not occur until the cost of DE is lowered, along with the cost of its power electronics.

### 3.5 Analysis Challenges

Existing power system analysis packages have been adequate for distribution system analysis, given the traditional operation of these networks with a more than adequate operating margin. However, new digital loads that demand higher power quality, and shrinking operating margins, are making the dynamics of distribution system operation more important. These analysis packages are based on the radial nature of distribution systems and use linear characteristics to model the various loads. In order to model DE devices, the active (P) and reactive (Q) power models of these loads must be used, but with negative values when power is injected into the system from a source. None of these analysis models can adequately model the nonlinear characteristics or control capabilities of power electronics, which is important. As the dynamic characteristics of power electronics-based DE come more into play, this aspect will become more and more important.

The analysis of multiple versus individual DER devices presents a real challenge for existing analysis tools. In most cases, the output of DER systems is modeled using the P and Q model of the steady-state distribution analysis programs. However, the distinct advantage offered by DER systems with power electronics is the ability to dynamically or transiently provide power either to local loads or to support the grid. Neither the economic nor the technical advantages of DER systems with power electronics can be assessed or forecast until adequate software tools are available to consider different power electronic systems, controls, and communications.

Rotating DE (synchronous generators or condensers) and static DE (inverters) offer different challenges for the operation of the distribution system. Rotating-based DE can contribute high current to faults (no theoretical limit), while static-based DE is limited by the inverter. The challenge will be to model the fault contribution from multiple DE sources when they represent a significant penetration of the network capacity.

Optimally, DE placed in the right electrical locations on the distribution network can have the most impact on supporting the distribution system in ways such as voltage regulation. Rules of thumb are to place DE farther from the substation so that it can better provide voltage regulation for a given distribution circuit. Optimal analysis methods need to be developed to achieve maximum loss reduction, capacity relief, and voltage regulation from DE. Also, the sensitivity of

the distribution system to load changes and how this relates to DE operation for services such as voltage regulation needs to be modeled.

### **3.6 DER Systems Reliability**

The key to optimal operation and performance of DER systems is onboard diagnostics that could be incorporated into the power electronic systems. The diagnostics could track the DER performance to identify out-of-range parameters as well as identify degradation over operation time. Another key component is the development of better materials and packaging to increase the operational life and decrease the cost of power electronics for DER systems.

### **3.7 Dynamic and Local Regulation**

DER systems offer the capability to lower capacity losses and losses of distribution lines by providing more of the power closer to where it is being used. A real unknown is how multiple DER systems will interact in a distribution system with smart electronics and controls. A necessary activity is the development of control algorithms for power electronics and the testing of these algorithms with multiple systems. Also, DER systems can regulate voltage and power factor locally, but the issue of what level of communications would be needed for multiple DER devices located on the system is a concern. Again, development of smart controls is needed for power electronics-based DER systems.

### **3.8 Provision of Ancillary Services**

Reliability and quality are the two most important facets of any power delivery system. In recent times, the issues involved with power quality and custom power solutions have generated a tremendous amount of interest among power system engineers. Since these power quality problems result in so much loss to utility users, ancillary services must be provided to solve them.

Providing ancillary services from DER can be a solution to power quality problems for the following reasons:

- Local voltage and frequency regulation is much more efficient with local sources, and the DER can supply precisely the level of regulation needed. Here regulation means not only the regulation of voltage but also the regulation of frequency. So DER is appropriate to provide voltage, network stability, load following, and regulation.
- Both harmonic compensation and network stability require fast response capability. DER equipped with power electronics can provide these two ancillary services.
- DER is perfect to provide backup supply and peak shaving because of its proximity to the user. In fact, DG applications today are primarily designated for backup and peak power shaving conditions.

For backup supply, the basic principle is that during forced utility outages, the DER supply the load. The control method is to control the output voltage of the DER to give the load uninterruptible supply. For peak power shaving, the DER are controlled to provide power only during high-demand periods so that the customer can avoid excessive demand charges by the utility.

If the power electronics inverter's function were used fully, then the DER could provide many more ancillary services. The following eight other ancillary services [5] could be provided by improving the DER inverter and its control methods:

1. **Voltage control and reactive power compensation:** Voltage control is the injection or absorption of reactive power by generation and transmission equipment to maintain transmission system voltages within required ranges or maintain the bus voltage of critical or sensitive loads.
2. **Frequency regulation:** Frequency regulation is the use of online generation units that are equipped with governors and automatic generation control. The method is to control the current from the DER to let it provide higher amounts of real power as the frequency of the system decreases, or smaller amounts of real power if the system frequency exceeds the nominal frequency (60.0 Hz in the United States).
3. **Load following:** DER sell some power to the utility and, at the same time, supply the load and track the changes in customer needs.
4. **Spinning reserve:** Normally, spinning reserve is the use of generating equipment that is online and synchronized to the grid so that the generating equipment can begin to increase output delivery immediately in response to changes in interconnection frequency, and can be fully utilized within seconds to correct for generation/load imbalances caused by generation or transmission outages [6]. Most on-line DER could perform spinning reserve and respond in less than 10 seconds.
5. **Non-spinning reserve:** Supplemental reserve (non-spinning) is the use of generating equipment and interruptible load that can be fully available to correct for generation/load imbalance caused by generation or transmission outages. Supplemental reserve differs from spinning reserve only in that supplemental reserve needs to respond to an outage immediately, whereas spinning reserve should respond within 10 minutes. Most DER systems can respond in just 2 or 3 minutes from a completely turned-off state.
6. **Harmonic compensation:** Harmonic compensation is the use of online generation equipment to compensate for harmonics caused by nonlinear loads. Harmonics can cause poor power quality, voltage imbalances, and excessive zero-sequence currents. The power electronics interface associated with DER could perform a harmonic compensation function.
7. **Network stability:** Network stability is the use of special equipment at a power plant (e.g., power system stabilizers or dynamic resistors) or on the transmission system (e.g., dc lines, FACTS, energy storage) to help maintain transmission system reliability. By monitoring frequency fluctuations and controlling DER import/export, DER could provide network stability functions. The control method is similar to regulation and load following; however, network stability has a more demanding fast-response requirement.
8. **Seamless transfer:** When DER transfer from stand-alone mode to grid-connection mode or vice versa, they are expected to transfer seamlessly. In a wider definition, seamless transfer is the capability for online generation to transition among various ancillary services without power delivery disruption [7].

### 3.9 Recommendations

In order to more effectively utilize power electronics in DE system and increase DE value streams, DOE could consider the following recommendations:

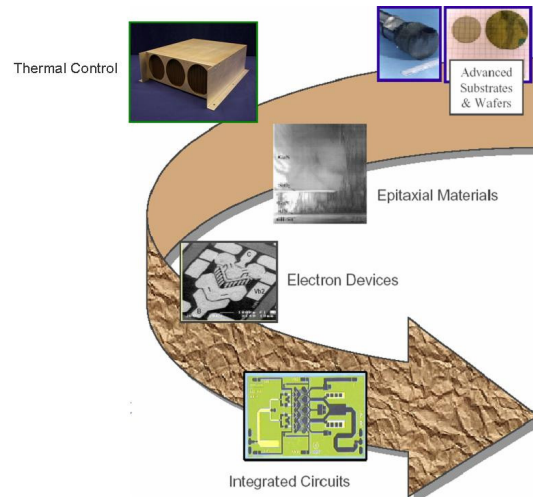
1. Develop new materials and packaging to decrease the cost of power electronics for DER systems.
2. Develop software tools that can analyze the dynamic capabilities of power electronics–based DER systems.
3. Standardize controls and communication interfaces for power electronics for DER systems.
4. Develop new distribution circuit designs that offer none of the limitations of current radial systems and take greater advantage of power electronics–based DER systems.
5. Develop advanced control algorithms for power electronics systems to take full advantage of compensation capabilities of converter systems, such as reactive power injection. Evaluate the capability of DER systems to provide ancillary services and the likelihood of a market for those services.
6. Test single and multiple power electronics–based DER systems on distribution networks to identify the performance characteristics and limitations of existing technology.
7. Identify guidelines or “rules of thumb” for the interconnection and operation of single and multiple DER systems with power electronics.
8. Develop analysis tools that can help optimize the placement of DER in a system so that they have the greatest positive impact on the distribution network.

## 4. SILICON POWER ELECTRONIC SEMICONDUCTORS

As a solid-state type device, a power electronics device performs many diverse functions and is the modern replacement for electromechanical devices. It has high enough blocking voltage to avoid series stacking except in applications of more than 10 kV, and no associated packaging difficulties at high voltage levels. It also has high enough switching frequency to lead to fast dynamic power processing ability. In addition, the solid-state device has much more accurate operation, much better stability, and much lower space requirements, among other advantages.

Today, silicon (Si) -based power devices dominate the power electronics and power system applications. They offer many advantages to customers, but at the same time they suffer from limitations in their material properties. This opens a door for new materials to enter the power electronics field. Wide bandgap materials show great potential in this area, especially silicon carbide (SiC).

As shown in Fig. 4.1, research on power semiconductors focuses mainly on material technology, device technology, thermal control technology, and packaging technology.

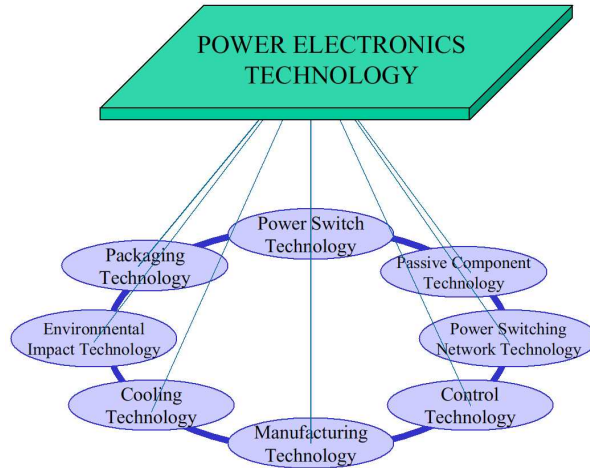


**Fig. 4.1. Power semiconductors focus areas [1].**

The main concerns related to power devices are summarized as follows:

- Power switch technology (device technology, driving, snubbing, and protection technology)
- Passive component technology (magnetic, capacitive, and conductive components)
- Power switching network technology (i.e., what is classically termed converter technology, covering the switching technologies such as hard switching, soft switching, and resonant transition switching)
- Packaging technology (materials technology, interconnection technology, layout technology)
- Environmental impact technology [acoustic interaction; electromagnetic interference (EMI) and electromagnetic compatibility (EMC); and physical material interaction, i.e., recycling, pollution, and takeback]
- Cooling technology (cooling fluids, circulation)
- Manufacturing technology
- Converter control technology

These technologies are strongly interactive, and they sum to comprise the entire realm of today's power electronics technology, as shown in Fig. 4.2.



**Fig. 4.2. Realm of power electronics technologies [2].**

This chapter covers the main issues of power electronic technologies for Si-based power devices. It discusses the present status and prospects of these power electronics technologies and discusses their advantages and obstacles. More details on SiC, gallium nitride (GaN), and diamond-based power electronics are found in Chapter 5.

#### **4.1 Historic Review of Development of Silicon Power Electronic Devices**

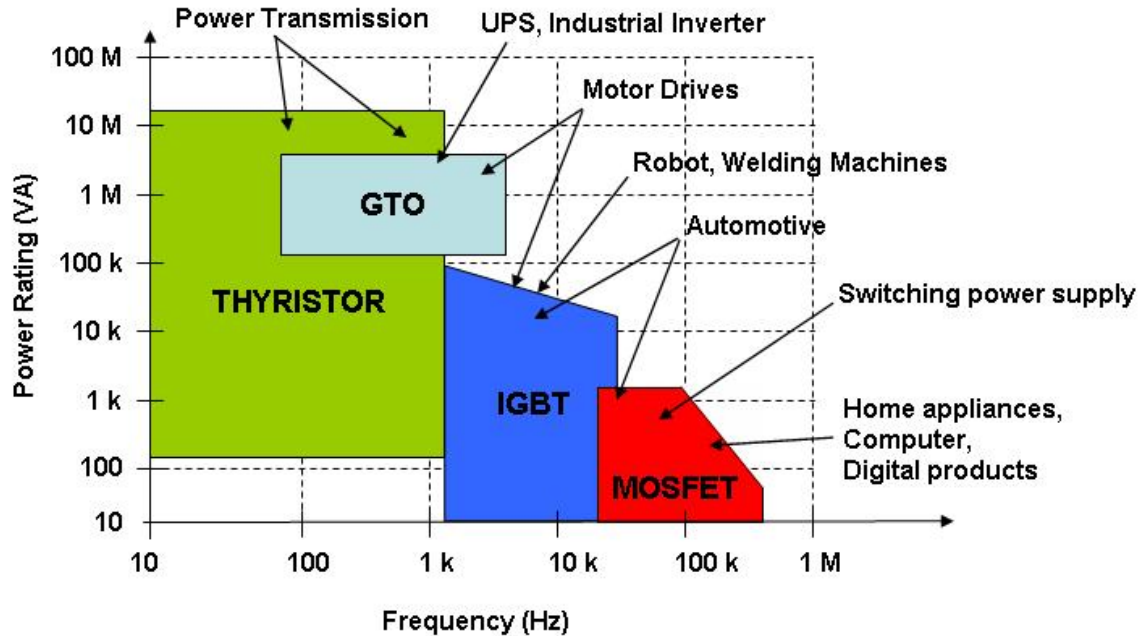
The development of advanced power electronic devices has been accelerated as a result of the emergence of changes and breakthroughs achieved in the areas of power semiconductor device physics and process technology.

Power electronics started with the invention of the bipolar junction transistor (BJT) in the 1950s. In the 1960s, the appearance of the thyristor started the first stage in the history of high-power semiconductor devices and opened up many possibilities for the growth of power electronics for utility applications. In the second half of the 1970s, the two controllable non-latching-type devices, the bipolar transistor module and the gate turn-off thyristor (GTO), were developed and introduced to match the growing demand for inverter-controlled power conversion equipment, which quickly became the focus of power electronics growth [3].

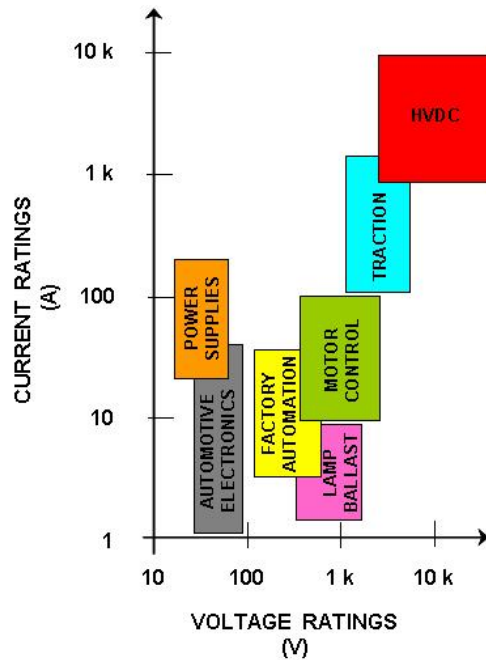
This started the second stage in the chronological evolution of power semiconductor devices. The introduction of power MOSFETs (metal oxide semiconductor field effect transistors) in the 1970s enabled compact and efficient system designs, particularly those for low-voltage (less than 200-V) applications. To improve performance and reliability, the double-diffused MOS (DMOS) process and trench gate technologies were subsequently adopted in the early 1980s, and these became the predominant options for device manufacturers. The third stage in the late 1980s through the early 1990s focused on MOS-gated device physics blended with the bipolar transistor [3]. As a result, the revolutionary power device, the insulated gate bipolar transistor (IGBT), was put into practical use. It has been a key component for the insertion of power electronics into many applications such as portable electronic devices; variable-speed motor drives; and utility applications such as FACTS, HVDC, and interfaces with DE energy sources.

## 4.2 Overview of Silicon Power Electronic Devices

High-power electronic devices are used in the transportation sector (e.g., aviation, marine, and traction applications), generation, T&D, and emerging areas such as FACTS, power quality, and custom power. Some typical applications are listed in Fig. 4.3.



(a)



(b)

Fig. 4.3. Today's device capabilities and application needs (a). Comparison of today's devices application fields and regions of operation [4] and (b) voltage and current requirements for devices per region of operation.

The fundamental building block of power electronic devices is the power semiconductor. Power semiconductors are essential components of most electronic devices and systems. Silicon is by far the most widely used semiconductor material. Recently, several other compound semiconductor materials have been used to develop prototype power electronic devices. These materials include gallium arsenide, indium phosphide, silicon germanium, GaN, and SiC. SiC MOSFETs and IGBTs have the most promise in terms of voltage and current ratings for utility applications in the future (discussed in more detail in Chapter 5). SiC MOSFETs and IGBTs are not commercially available. In fact, SiC IGBTs are not as developed as MOSFETs, and MOSFETs are not expected to be available until 2006. Until then, Si will continue to dominate the present commercial market.

The self-commutated power semiconductor devices can be classified into one of two categories: thyristors or transistors. Thyristors have large power ratings with a current-controlled gate to turn on if forward biased. Once on, a thyristor cannot be turned off by the gate. It turns off when the thyristor is reverse biased. Transistors are amplifiers that can allow large collector currents to be varied by a small controlling base current in conventional bipolar transistors or, in the more sophisticated IGBTs or MOSFETs, by a gate voltage requiring very little current and hence little control power. The gate control circuit can vary the speed at which switching on or off occurs. Transistors such as IGBTs and MOSFETs allow much more freedom in controlling the switching of converters, whereas thyristors and GTOs are very limited in their control abilities. The devices in the high-power application fields under serious consideration for the present are thyristors, IGBTs, GTOs, and integrated gate-commutated transistors (IGCTs). But it is likely the IGCT will eventually replace the GTO because of the IGCT's inherent lower losses and simpler gate drive [5]. Some of these devices are summarized in Table 4.1.

**Table 4.1. Available self-commutated power semiconductor devices**

Thyristors	Transistors
GTO (gate turn-off thyristor)	Bipolar transistor
MCT (metal oxide semiconductor-controlled thyristor)	Darlington transistor
FCTh (field-controlled thyristor)	MOSFET (MOS field effect transistor)
SITh (static induction thyristor)	FCT (field controlled transistor)
MTO (MOS turn-off thyristor)	SIT (static induction transistor)
EST (emitter-switched thyristor)	IEGT (injection enhanced gate transistor)
IGTT (insulated gate turn-off thyristor)	IGBT (insulated gate bipolar transistor)
IGT (insulated gate thyristor)	
IGCT (integrated gate-commutated thyristor)	
ETO (emitter turn-off thyristor)	

### 4.2.1 Thyristor

The thyristor, or silicon-controlled rectifier (SCR), is the equivalent of a current valve with two discrete states, either conducting (ON) or blocking (OFF). Turn-on is accomplished by injection of a gate current; turn-off is not possible using the gate. Instead, a reverse bias is applied to the thyristor, and the device turns off when the current through it goes to zero. Thyristors are suitable in utility applications because when the 50/60 Hz line voltage across the thyristor goes negative, the current through it goes to zero, naturally turning off the device. Since a thyristor cannot be turned off with the gate terminal, its range of applications is significantly limited. As shown in Fig. 4.4, thyristors have been the workhorses for utility-scale power electronics for more than 30 years; presently they are available with impressive power handling capabilities (12 kV/4 kA) and often represent a cost-efficient alternative for the highest power levels.





Fig. 4.4. 4500-V/800-A and 4500-V/1500-A thyristors [6].

#### 4.2.2 GTO and IGCT

The GTO, shown in Fig. 4.5, makes it possible to build efficient converters for output frequency control. The development of the GTO opened the way to high-power variable-speed ac motor drives and other similar applications because a GTO, unlike a thyristor, can be turned off by injecting a large negative current to the gate. However, disadvantages of a GTO compared with a conventional thyristor include higher power losses and the need for elaborate units for snubber circuits for individual device protection, as well as for supplying the high gate currents—up to 1/3 of the main current being conducted by the GTO. A performance improvement in the GTO resulted in the introduction of the IGCT (or GCT) in 1997, shown in Fig. 4.6. This new technology features an integrated gate drive unit. With this concept, the free-wheeling diode, needed in anti-parallel with the switches in many converter concepts, can be integrated on the same semiconductor wafer, simplifying the mechanical design of the converter [7]. The IGCT has a significant loss reduction compared with the GTO. With its proven high reliability, the IGCT represents an optimal cost-efficient choice in many high-power applications requiring turn-off devices and is currently used in large motor drive systems and traction power-supply systems.

Presently, the available power handling capabilities of GTO and IGCT modules are rated as high as 6.5 kV/6 kA.



Fig. 4.5. 4500-V/800-A and 4500-V/1500-A GTOs [6].



Fig. 4.6. 6500-V/1500-A symmetrical GCT [6].

### 4.2.3 MOSFETs

Power MOSFETs are unipolar, majority carrier, voltage-controlled devices, making them superior to bipolar devices (BJTs and IGBTs) in faster switching speeds, lower switching losses, and simpler gate drives. The gate is composed of a silicon dioxide layer, called metal oxide, that normally insulates the source from the drain. Once a forward-biased voltage is applied to the gate with respect to the source, the source becomes electrically conductive to the drain, allowing the flow of appreciable currents.

One major limitation of power MOSFETs is on-state resistance, which contributes to conduction losses. The on-state resistance limits the current ratings, because the power being dissipated from the device is in the form of waste heat and is found by using  $P = I^2 R$ , where  $P$  is the power dissipated,  $I$  is the rms current being conducted, and  $R$  is the on-state resistance. Increasing the current increases the internal junction temperature of the device. The internal junction must dissipate this waste heat or the device will fail. Another major limitation in MOSFETs is the metal oxide layer, which limits the voltage breakdown. Together, the current-carrying capability is inversely proportional to the voltage-blocking capability, rendering MOSFETs as either low-current with higher voltage blocking devices or higher-current with lower voltage devices. One such MOSFET is shown in Fig. 4.7.

Today power MOSFETs are used in applications such as power supplies and home appliances that require relatively low (<100 V) blocking voltages and high switching speeds (>100 kHz).



Fig. 4.7. Silicon MOSFET with ratings of 150 V/600 A.

### 4.2.4 IGBT

The IGBT in Fig. 4.8 is one of the most popular power electronic devices at present. The IGBT combines the high-impedance, low-power gate input of a MOSFET with the power handling capacity of bipolar transistors and thyristors. The MOS gate allows a high impedance control of the current flow through the device, requiring extremely small amounts of power supplied to the control gate. The ability to sustain high voltages and currents is provided by the vertical part of the device, comprising a bipolar transistor structure. This vertical transistor also gives a sufficient thickness for withstanding high voltages. In addition, the vertical transistor effect is crucial to enhance the conductivity of the semiconductor material and hence to reduce excess voltage drop over the device in the conducting stage.

Although substantial progress was made in IGBT development for lower voltages (600–1200 V) in the 1980s, it was not until the beginning of the 1990s that it was realized that this technology also was feasible for higher voltages. Now the available power handling capabilities of IGBT modules can reach ratings as high as 6.5 kV/4 kA. As the power ratings for these devices continue to increase, it is expected they will replace GTOs and thyristors in utility applications.



Fig. 4.8. 1700-V/1200-A and 3300-V/1200-A IGBT modules [6].

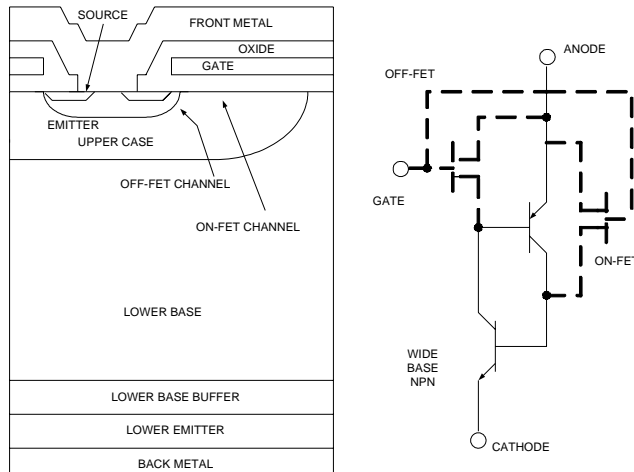
#### 4.2.5 MOS-Controlled Thyristor

The MOS-controlled thyristor (MCT) is a new type of power semiconductor device that combines the high-voltage-blocking capabilities and high-current capabilities of the thyristor with MOS gated turn-on and turn-off. The development was announced by the General Electric R&D Center in the early 1990s. It is a high-power, high-frequency, low-conduction-drop rugged device. The MCT has a thyristor-type structure with three junctions and PNP layers between the anode and cathode. In a practical MCT, about 100,000 cells similar to the one shown in Fig. 4.9 are paralleled to achieve the desired current rating. The MCT is turned on by a negative voltage pulse at the gate with respect to the anode and is turned off by a positive voltage pulse [8]. Figure 4.9 shows a cross-sectional structure of a p-type MCT with its circuit scheme.

The advantage of an MCT over an IGBT is its low forward voltage drop and relatively low switching times and storage time. Since the power gain of an MCT is extremely high, it could be driven directly from logic gates. However, the device has a limited safe operating area; therefore, a snubber circuit is mandatory in an MCT converter. Also, in spite of its complex geometry, the current density of an MCT is high compared with a power MOSFET and IGBT; therefore, it needs a smaller die area. These disadvantages have hampered its application, and the MCT has not gained widespread acceptance in the power electronics community. Development has been almost abandoned since the great strides in IGBT development occurred.

#### 4.2.6 Emitter Turn-Off Thyristor

Based on the integration of the GTO and power MOSFET technologies, the emitter turn-off (ETO) thyristor is a new type of high-power semiconductor device that is suitable for use in high-frequency and high-power converters. The ETO has a wide reverse-biased safe operation area and snubberless turn-off capability. Also, depending on the amplitude and rise rate of the gate current, as well as the structure of the GTO, an ETO can be uniformly or non-uniformly turned on. Since the gate driver of the ETO is tightly integrated with the ETO, as shown in Fig. 4.10, the ability to provide the desired gate turn-on current is greatly improved compared with the GTO.



**Fig. 4.9. A cross sectional structure of a p-type MCT with its circuit scheme.**



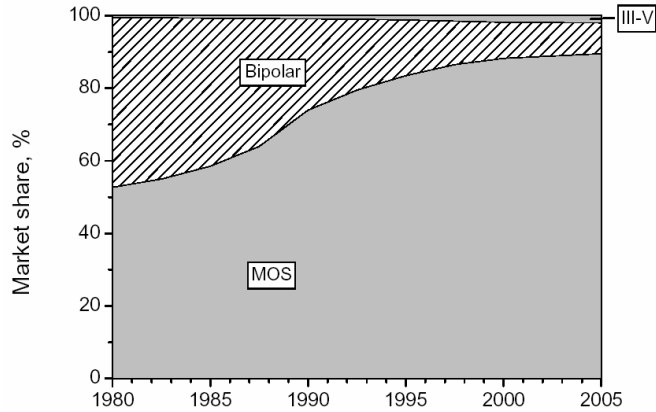
**Fig. 4.10. 4000-A/4500-V ETO with the integrated gate driver [9].**

By optimally integrating commercial GTOs with MOSFETs, the ETO offers the advantages of high-power rating (up to 6 kV and 4 kA), low conduction loss, fast switching speed (up to 5 kHz), snubberless turn-off capability, built-in current sensing, and capability of parallel and series operation. Virginia Tech and North Carolina State University researchers are developing the ETO project with funding from the Tennessee Valley Authority, Sandia National Laboratories (DOE), and the Department of Defense (DOD).

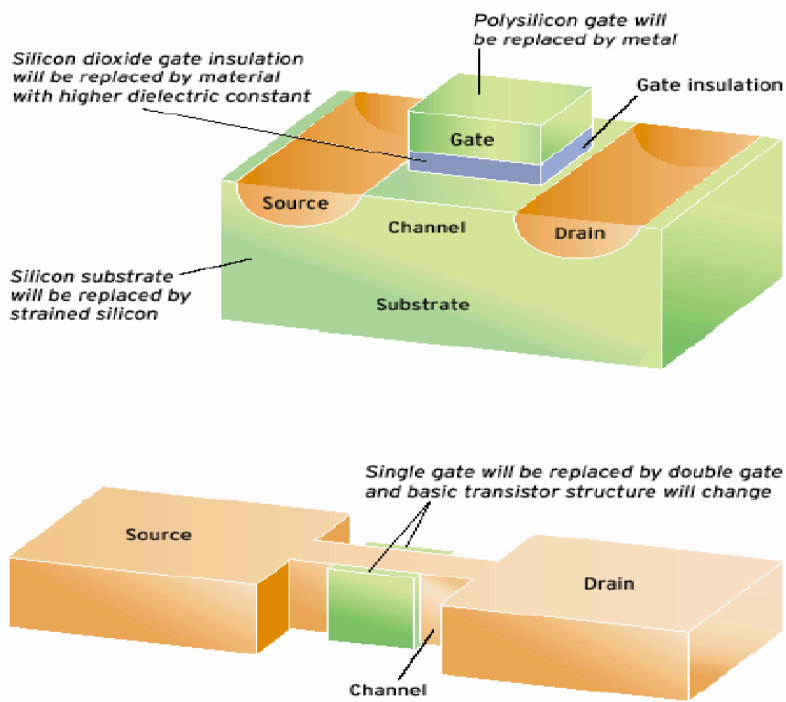
#### 4.2.7 Other Novel Device Structures

The reverse conducting IGBT is based on a light-punch-through type CSTBT<sup>TM</sup> (carrier-stored trench bipolar transistor) design using a new thin wafer technology. Through various static and dynamic tests, this novel device has the potential to become the most attractive choice as a power switch for low- to medium-power inverter applications in the near future. Reverse blocking IGBTs may be a good choice for circuit topologies that need bi-directional switches, such as a matrix converter [1].

As shown as Fig. 4.11, MOS devices will dominate the future power electronics market. In order to maintain performance levels, future generations of transistors will need to be not only smaller than today's but also different in more fundamental ways in order to achieve simpler gate drives, higher reliability, easier thermal management, and simpler manufacturing processes. Figure 4.12 gives an example of future MOS device technologies that are being developed.



**Fig. 4.11. Market share of semiconductor devices (University of Florida, Gainesville, FL) [10].**



**Fig. 4.12. Future MOS devices with silicon technologies (University of Florida, Gainesville).**

One typical sample of technology progress for silicon devices is the CoolMOS™ device. These devices show no bipolar current contribution like the well-known tail current observed during the turn-off phase of IGBTs. CoolMOS virtually combines the low switching losses of a MOSFET with the low on-state losses of an IGBT [11]. Furthermore, the dependence of on-resistance on the breakdown voltage has been redefined. The more than square-law dependence in the case of a standard MOSFET has been overcome and linear voltage dependence achieved, opening the way to new fields of application even without avalanche operation. System miniaturization, higher switching frequencies, lower circuit parasitics, higher efficiency, and reduced system costs are encouraging its future development. Not only has the new technology

achieved a breakthrough with reduced on-resistance values, but also new benchmarks have also been set for the device capacitances.

The CoolMOS also makes the super-junction (SJ) concept possible. The SJ concept is based on a device structure that is applicable not only to MOSFETs but also to other unipolar devices [12]. Figure 4.13 shows a comparison in cross-section between a conventional MOSFET and an SJ-MOSFET. The on-resistance value of a 1-kV SJ-MOSFET is theoretically projected to be one-tenth or one-hundredth as low as that of a conventional 1-kV device.

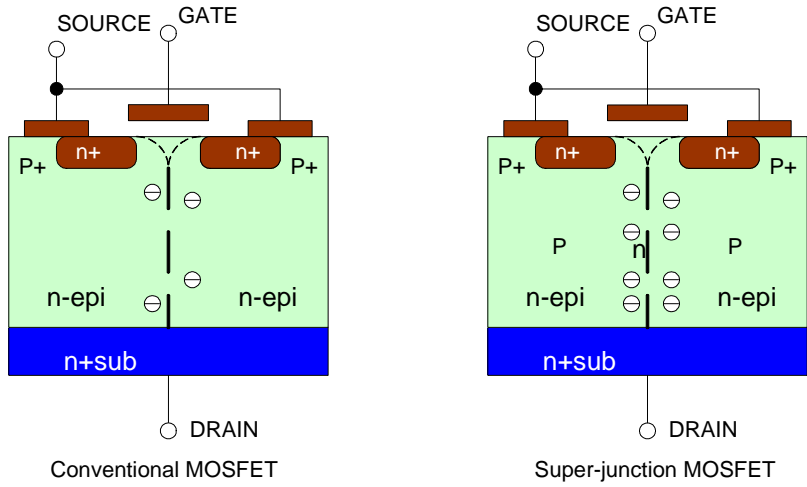


Fig. 4.13. Device structure of MOSFETs.

### 4.3 Power Device Manufacturers

Power semiconductor devices belong to a separate segment of the mass semiconductor application market and are mainly sold as discrete devices or modules in the marketplace, differing both in production technology and in end-user applications. These devices are aimed to receive, process, and switch from a few watts to megawatts as quickly and efficiently as possible. The power semiconductor industry has changed significantly in the past decade.

Today, approximately 80 power semiconductor manufacturers are serving the North American market. Their products consist mainly of thyristors, transistors, rectifiers, and power integrated circuit devices. The power electronic devices with voltage and current ratings of more than 1000 V/100 A that are available from power semiconductor device manufacturers are listed in Table 4.2. Contact information for these companies can be found in Appendix C.

### 4.4 New Materials Usage

Silicon is a mainstream material used in power semiconductor production for all device types with low cost. However, the Si-based power switching devices are reaching fundamental limits imposed by the low breakdown field of the material. A substantial improvement can be achieved only by using a new semiconductor material with higher field characteristics. Manufacturers are exploring the possibilities of using compound semiconductors for specific devices.

The most promising material for the next generation of power electronics is SiC, whose material properties make it a natural choice for high-power, high-temperature, and high-frequency applications. Materials such as GaN, InN, and diamond are also expected to play an increasing role in the power electronic device field in the future. Further discussion of these wide bandgap materials is found in the next chapter.

**Table 4.2. High-power electronics manufacturers and products**

	Company	Product	Rating	Notes
1	Powerex Inc.	IGBT Modules Phase Control SCRs Inverter Grade SCRs GCT/SGCT/GTO	250–6500V, 10–2400A 200–6500V, 40–5000A 200–2500V, 40–3000A 2500–6500V, 400–6000A	
2	Mitsubishi Electric & Electronics USA, Inc.	IGBT Modules GTOs GCTs Thyristors	Up to 4500V, 2400A 2500/4500/6000V, 1000–6000A 4500/6000/6500V, 400–6000A Up to 12000V, 2500A	Powerex Inc. is responsible for the sales and support for Mitsubishi power devices in North America.
3	IXYS Corporation	IGBT Discretes IGBT Modules Thyristors	1200V, 150A/100A Up to 6500V, 1800A Up to 4900V, 180A	
4	Westcode Semiconductors	IGBT Press-packs GTOs Distributed Gate Thyristors Phase Control Thyristors	2500/4500/5200V, 160–1500A 1700–6000V, 500–4000A Up to 5200V, 3000A 3200–6500V, up to 4000A	Westcode Semiconductors Company was acquired by IXYS Corporation in December 2001.
5	ABB Semiconductors Inc.	IGBTs GTOs IGCTs Thyristors	1200–6500V, 100–2400A 2500–6000V, 1500–4000A 2500–6000V, 275–4000A 1200–6500V, 300–4500A	IGCT rated at 10 kV is in planning
6	International Rectifier (IR)	IGBT Discretes IGBT Co-packs	1200V, 99A 1200V, 120A/99A	
7	Advanced Power Technology Inc.	IGBT Discretes IGBT Modules	1200V, 100A 1200/1700V, up to 600A	
8	Eupec Inc.	IGBT Modules SCR/Diode Modules	Up to 6500V, 3600A Up to 4400V, More than 1000A	
9	Fuji Semiconductor	IGBT Modules	1200/1400/1700/1800V, up to 800A	
10	Sensitron Semiconductor	IGBT Modules	1200V, 100A/200A	
11	Infineon Technologies	IGBT Discretes	1200V, 100/150A; 1700V, 100/125/150A	
12	Toshiba Corporation's Semiconductor Company	IGBT Modules IEGTS	1700V, 1200A; 2500V, 1000A 3300V, 400–1200A; 4500V, 900–2100A	IEGTS rated 6500 V/ 600 A is in planning
13	SEMIKRON Inc.	IGBT Modules Thyristors	1200/1700V, up to 960A Up to 2200V, 2000A	
14	Hitachi America, Ltd.	IGBT Modules	1700/2000/2500/3000/4500V, up to 2400A	
15	Dynex Semiconductor	IGBT Modules GTOs Thyristors	1200/1700/3300/6500V, up to 3600A 1300/1800/2500/4500/6500V, up to 4000A Up to 6500V, 1300A	



#### **4.5 Innovation in Design of Power Electronics System as a Whole**

New ideas and concepts have been developed in recent years that allow for the use of different topologies in power electronics systems. It is important to consider new developments comprehensively in designing whole systems. For instance, the inadequate performance of passive components operating at high switching speeds is a critical barrier. The state-of-the-art versions of these passive components are probably not suitable for handling these high speeds. Continued efforts to develop cost-effective and volume-efficient capacitors and magnetic components are imperative because continued advances depend on them [13]. Improvement is needed in high-temperature operation and reliability. The major challenge in designing comprehensive power electronics systems is to simplify the overall circuit design, cost, and size while improving performance.

Major advances in the next generation of power electronic device technologies will depend mainly on finding solutions to multidisciplinary issues in materials, circuits, system integration, packaging, manufacturing, marketing and applications.



## 5. WIDE BANDGAP POWER ELECTRONICS

### 5.1 Challenges of Silicon Semiconductor Technology

With the most advanced and mature technology for power electronics devices, silicon (Si) power devices can be processed with practically no material defects. However, Si technology has difficulty in meeting the demand for some high-power utility applications as a result of limitations in its intrinsic material properties.

#### Voltage Blocking Capability

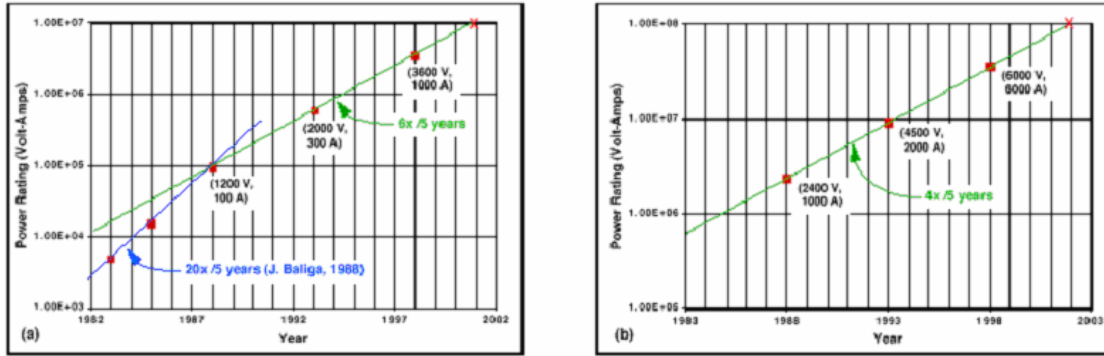
The primary limitation, voltage blocking capacity, is due to Si's relatively narrow bandgap (1.1 eV). This bandgap leads to a low intrinsic breakdown electric field, which is approximately 300 kV/cm in undoped material and even smaller in doped material. Correspondingly, the voltage blocking capacity of Si devices is less than 10 kV. For high-voltage applications, stacking packaged devices in series is required, such as series stacking of thyristors that is common in high-voltage inverters of HVDC stations. Series stacking is expensive from a packaging standpoint, and it requires complicated triggering to maintain voltage-sharing between devices in the stack. Hence there is a strong incentive to develop devices having greater voltage blocking capacity in the same or a smaller device package. Such devices could be used in a variety of utility switching applications, from distribution levels (tens of kV) to transmission levels (>100 kV). Many of these applications are aimed at improving power quality and reliability and fall in the category of FACTS or HVDC.

To compensate for the low breakdown field in Si devices, the active layer is usually very thick so that the voltage drops over a long region of semiconductor, reducing the associated internal electric fields. However, this long active layer contributes to large on-state resistance and, in turn, large power losses, limiting efficiency; and it has significant influence on current density and switching speed. This is a tradeoff in device design.

Presently, between approximately 100 V and 1 kV, Si power electronics have had great impact because of rapid advances in the IGBT and in modular packaging. For voltages above 1 kV, Si has made an impact through remarkable advances in the electrical performance of both IGBTs and GTO thyristors. More and more IGBTs have been connected in parallel to create large modules, and single GTO thyristors have been manufactured at up to 150 mm in diameter, leveraging the advances in substrate and fabrication technology made possible by the Si digital industry. However, these improvements have occurred mostly through current handling. Initially, the power handling of IGBTs increased at a rate of roughly 20× every 5 years, as shown in Fig. 5.1. Around 1988, the rate of growth diminished to approximately 6× every 5 years. There are good reasons to believe that it will begin to saturate in the future, in spite of the steady growth of current handling in the previous decade.

#### Thermal Conductivity

Low thermal conductivity limits the operational temperature of Si devices. The normal operational temperature limit is less than 150°C, and a significant thermal management effort is required to maintain the junction temperature of these devices below that limit. There are three standard options for cooling power devices—natural air, forced air, or water-cooled heat sinks. As the temperature of the environment increases, the capacity of the cooling system decreases. The power rating of the converter determines the type of heat sink to use. For low-power converters, bulky, natural air-cooled heat sinks are sufficient; whereas high-power converters



**Fig. 5.1. The advance in power handling capacity of IGBT switches between 1983 and 1998 (a) and improvements in GTO thyristors over the past decade (b) [1].**

require more expensive but smaller liquid-cooled heat sinks. However, the latter require a pump to circulate the coolant, as well as a radiator and a fan to cool it. A heat sink typically occupies one-third of the total volume of a power converter and usually weighs more than the converter itself. Manufacturing power electronics devices that can withstand higher temperatures is one way of decreasing the cooling requirements, size, and cost of the converter. Additional details on thermal management and packaging of power electronics devices are found in Chapter 6 of this report.

### Temperature Limits

Si devices have reached their theoretical temperature limits. These power devices have losses associated with conducting and switching high currents. The amount of loss depends on the type of power devices used. In high-power applications, IGBTs and PiN diodes are presently used. Both are bipolar devices and have higher losses than their unipolar counterparts, such as MOSFETs and Schottky diodes. Although unipolar devices have lower on-state and switching losses than bipolar devices, they are not used in high-power devices because they lack sufficient voltage blocking capability. Building higher-voltage-rating MOSFETs and Schottky diodes would not be feasible because as the breakdown voltage increases, the device requires a large silicon die area, resulting in reduced manufacturing yields and increased costs. For higher breakdown voltages, a material with a higher electric breakdown field is required; therefore, wide bandgap devices have gained the attention of researchers and manufacturers as a possibility for the next generation of power electronics.

### Switching Frequency

The switching frequency of these devices is also limited because of the heat generated by switching losses in the devices. Typically, Si devices have a switching limit of less than 20 kHz for power levels in the range of a few tens of kilowatts and are highly susceptible to harsh environments, such as high ambient temperatures and intense radiation. Since recent advances have driven Si power electronic devices to approach the material limits, the margin for switching speed to improve is rather small; however, higher-frequency operation is preferred because converters with higher switching frequencies allow smaller filtering requirements, less audible noise, smaller passive components, and exact control for high performance.

It is clear that the demands of power electronics will continue to increase; in the future, it will be even more difficult to make significant improvements in power electronics devices using Si. The use of alternative materials for power electronics is inevitable. Since the limits of Si-based power devices can be attributed to the narrow bandgap of Si, wide bandgap materials are good candidates as materials for next-generation power electronic devices.

## 5.2 New Materials for Power Electronic Devices

Research is being conducted for a high-performance building block that combines lower costs with improved performance and manufacturability. The application needs range from more efficient power supplies for consumer appliances, to hybrid electric vehicle power converters, to efficient long-distance high-voltage power transmission. Researchers have focused their attention on new semiconductor materials for use in power devices to address system improvements. Significant technical advances are occurring in the development of power semiconductor materials and designs to address these new needs. Of the contenders, SiC, gallium nitride (GaN), and diamond are emerging as the front-runners.

SiC is used for power devices such as Schottky diodes, JFETs, and MOSFETs, as well as MESFETs (metal-semiconductor field effect transistors) and blue LEDs. Because of its high thermal conductivity, SiC is also used as a substrate for other semiconductor materials.

GaN-based electronic devices, AlGaN/GaN heterojunction field effect transistors (HFETs), are the leading candidates for achieving ultra-high-frequency and high-power amplifiers. Recent advances in device and amplifier performance support this claim. GaN is comparable to the other prominent material options for power devices. GaN-based devices can be fabricated over either sapphire or SiC substrates to take advantage of higher thermal conductivity. However, there are problems associated with this material that make it difficult to build high-voltage devices. These problems will be discussed in Section 5.6.

Some scientists and technology researchers are attempting to make diamond-based power electronics devices because of the unique thermal, mechanical, electrical, and chemical properties of diamonds. Diamond is intrinsically suited for high-speed, high-power, high-temperature applications. It is viewed as the ultimate semiconductor, but it presents significant material process challenges that must be overcome before commercial devices are made with this material.

## 5.3 Characteristics of Wide Bandgap Devices

Wide bandgap semiconductor materials have superior electrical characteristic compared with Si. Power electronics devices based on wide bandgap semiconductor materials will likely result in substantial improvements in the performance of power electronics systems in terms of higher blocking voltages, efficiency, and reliability, as well as reduced thermal requirements. Some of these characteristics are listed for the most popular wide bandgap materials and Si in Table 5.1. The resulting device and system benefits are summarized in Table 5.2.

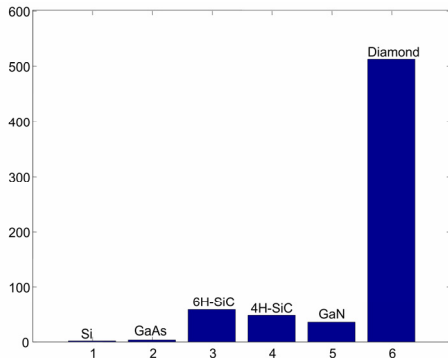
Figures 5.2–5.5 show some results of using these data to theoretically estimate the characteristics of power electronics devices made of these materials [2].

**Table 5.1. Physical characteristics of Si and the main wide bandgap semiconductors**

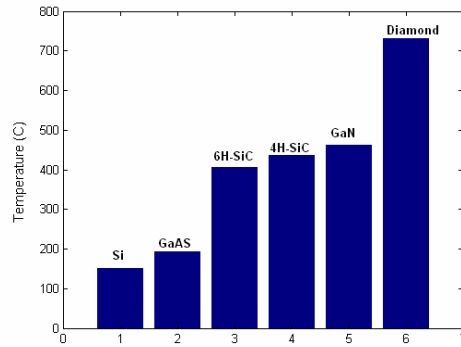
Property	Si	GaAs	6H-SiC	4H-SiC	GaN	Diamond
Bandgap $E_g$ (eV)	1.12	1.43	3.03	3.26	3.45	5.45
Dielectric constant, $\epsilon_r$	11.9	13.1	9.66	10.1	9	5.5
Electric breakdown field, $E_c$ (kV/cm)	300	455	2500	2200	2000	10000
Electron mobility, $\mu_n$ (cm <sup>2</sup> /V·s)	1500	8500	500	1000	1250	2200
Hole mobility, $\mu_p$ (cm <sup>2</sup> /V·s)	600	400	101	115	850	850
Thermal conductivity, $\lambda$ (W/cm·K)	1.5	0.46	4.9	4.9	1.3	22
Saturated electron drift velocity, $v_{sat}$ ( $\times 10^7$ cm/s)	1	1	2	2	2.2	2.7

**Table 5.2. Advantages of wide bandgap devices**

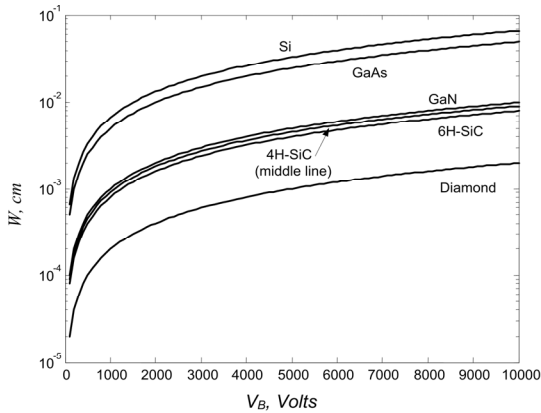
Material properties	Device characteristics	System benefits
High bandgap energy	High breakdown voltage	Large power capacity
High breakdown electric field	High current density	High efficiency, reliability
High thermal conductivity	High operational temperature	Less cooling requirements
High saturated e- drift velocity	High switching frequency	Reduced volume of passive components, for compactness
High radiation tolerance	Low power losses	



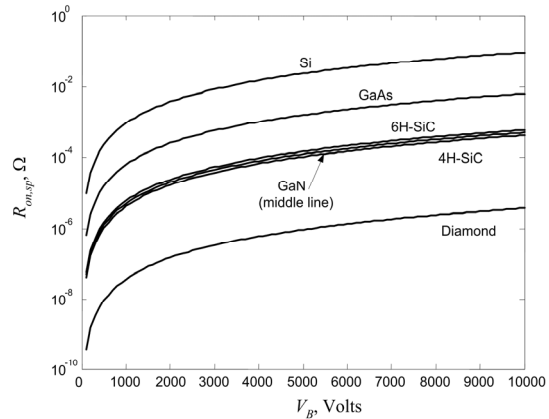
**Fig. 5.2. Maximum breakdown voltage of a power device at the same doping density normalized to Si [2].**



**Fig. 5.3. Maximum operational temperature assuming that it is 150°C for Si [2].**



**Fig. 5.4. Width of the drift region for each material at different breakdown voltages [2].**



**Fig. 5.5. Resistance of the drift region for each material at different breakdown voltages [2].**

### 5.3.1 Bandgap vs. Breakdown Voltage

Among all the semiconductors, diamond has the widest bandgap; consequently, it also has the highest electric breakdown field. SiC polytypes and GaN have similar bandgap and electric field values that are significantly higher than those for Si and GaAs. A higher electric breakdown field results in power devices with higher breakdown voltages. Figure 5.2 shows the breakdown voltages of diodes made of the materials in Table 5.1 that are calculated assuming the same doping density; the results are normalized to the breakdown voltage of an Si diode. As seen in this figure, the theoretical breakdown voltage of a diamond diode is over 500 times more than that of an Si diode. The breakdown voltage numbers for 6H-SiC, 4H-SiC, and GaN are 56, 46, and 34 times that of a Si diode, respectively. Note that with a higher electric breakdown field,

more doping can be applied to the material, which will further increase the gap between the upper breakdown voltage limits of the wide bandgap semiconductors and those of Si.

### **5.3.2 Bandgap, Thermal Conductivity vs. Maximum Operational Temperature**

The maximum operational temperature of a semiconductor material is determined by the bandgap. The temperature limit is reached when the number of intrinsic carriers approaches the number of purposely added (extrinsic) carriers. Therefore, semiconductors with wider bandgaps can operate at higher temperatures. Diamond has the widest bandgap, so its power devices have the capability to operate at higher ambient temperatures than other materials. The maximum operating temperature for each semiconductor is calculated by assuming a maximum operating temperature of 150°C for Si, and multiplying 150°C by the ratio of the bandgaps of Si and of the other material, as suggested by ref [3]. The results are shown in Fig. 5.3. Diamond has a distinct temperature advantage. The values for 6H-SiC, 4H-SiC, and GaN are similar, all above 400°C and much higher than 150°C for Si and 190°C for GaAs.

In addition, most wide bandgap devices have a greater thermal conductivity, so the material conducts heat to its surroundings faster, which means the device temperature increases more slowly. Diamond still leads the other materials by five times; the SiC polytypes are the next-best material. GaN, with a thermal conductivity comparable to that of Si, is the worst of the wide bandgap materials.

### **5.3.3 Electric Breakdown Field vs. Drift Region Width**

Another consequence of the higher electric breakdown field and higher doping is reduction of the width of the drift region, which enables smaller devices. The width of the drift region is calculated for all the semiconductors listed in Table 5.1, and the results are plotted in Fig. 5.4 for a breakdown voltage range of 100 to 10,000 V. Diamond, as expected, requires the minimum width, while 6H-SiC, 4H-SiC, and GaN follow diamond in order of increasing width. Compared with these, Si requires a drift region that is around ten times thicker.

### **5.3.4 On-Resistance**

Conduction loss is linearly related to on-resistance in power electronic devices. Conduction loss accounts for at least 50% of the losses in most power electronics applications. Reduction in on-resistance will increase efficiency accordingly. The last device parameter to be calculated from the properties in Table 5.1 is the on-resistance of the drift region for unipolar devices. The calculation results for on-resistance are plotted in Fig. 5.5 with respect to the breakdown voltage of the device. Again, diamond shows the best performance, with 4H-SiC following in order of increasing resistance. The on-resistance of the drift region for the Si device is around ten times more than for the SiC polytype and GaN devices.

### **5.3.5 Drift Velocity vs. Switching Speed**

Highly saturated electron drift velocity is another merit of wide bandgap materials. The high-frequency switching capability of a semiconductor material is directly proportional to its drift velocity. The drift velocities of wide bandgap materials are more than twice the drift velocity of Si; therefore, it is expected that power devices based on wide bandgap semiconductors could be switched at higher frequencies than their Si counterparts. Moreover, higher drift velocity allows charge in the depletion region of a diode to be removed faster; therefore, the reverse recovery current of diodes based on wide bandgap semiconductors is smaller, and the reverse recovery time is shorter.

### 5.3.6 Figures of Merit

To further explore the possible electronics performances of these materials, some commonly known figures of merit are listed in Table 5.3. In this table, the numbers have been normalized with respect to Si; the larger the number, the better a material's performance in the corresponding category. The figures of merit for diamond are at least 40–50 times those of any other semiconductor in the table. However, its processing problems have not been solved yet. According to the literature, diamond is used in sensors and field emission devices. There are no diamond power devices available yet. SiC polytypes and GaN have similar figures of merit, which imply similar performance. The material 4H-SiC is better in terms of FET performance. GaN devices are focused mainly on optoelectronics and radio frequency uses because GaN wafers are not large enough for appreciable currents. Among these wide bandgap semiconductors, SiC technology is the most mature one. Much research has been conducted on SiC materials and devices.

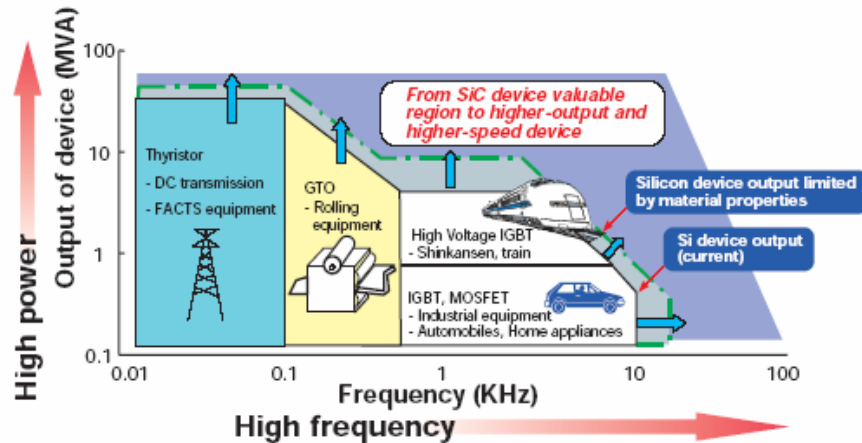
**Table 5.3. Main figures of merit for wide bandgap semiconductors compared with silicon [2]**

Measured performance	Si	GaAs	6H-SiC	4H-SiC	GaN	Diamond
Ultimate high-frequency capability	1.0	1.8	277.8	215.1	215.1	81000
Specific drift region on-resistance of a vertical FET	1.0	14.8	125.3	223.1	186.7	25106
FET switching speed	1.0	11.4	30.5	61.2	65.0	3595
Bipolar switching speed	1.0	1.6	13.1	12.9	52.5	2402
FET power handling capacity	1.0	3.6	48.3	56.0	30.4	1476
FET power switching product	1.0	40.7	1470.5	3424.8	1973.6	5304459
Bipolar power handling capacity	1.0	0.9	57.3	35.4	10.7	594
Bipolar power switching product	1.0	1.4	748.9	458.1	560.5	1426711

FOM = figure of merit.

### 5.4 System Benefits of Wide Bandgap Devices and Potential Applications

Figure 5.6 provides an overview of possible applications of wide bandgap-based devices. It also indicates that wide bandgap-based devices have superior intrinsic characteristics compared with Si. More details are presented in the following paragraphs.



**Fig. 5.6. Comparison of wide bandgap and SiC power electronics for power applications [4].**

## 5.5 Silicon Carbide

As discussed previously, the superior properties of SiC material result in a series of superior performances of power electronics made of SiC. Consequently, systems based on SiC devices show substantial improvements in efficiency, reliability, size, and weight even in harsh environments. Therefore, they are especially attractive for high-voltage, high-temperature, high-efficiency, or high-radiation uses, such as military, aerospace, and energy utility applications.

With the recent advances, power electronics interfaces to power systems such as static transfer switches, dynamic voltage restorers, static var compensators (SVCs), HVDC transmission, and FACTS are getting more and more attention. Some of these applications require voltage-blocking capabilities in the tens and hundreds of kV. Presently, there are no high-voltage/high-current single Si devices available for these applications. Instead, lower-rated devices are connected in series to achieve the necessary voltage rating, but at the cost of efficiency and reliability.

However, SiC MOSFETs and IGBTs with higher voltage blocking capacity may be able to meet system conditions with one device, without a need for several devices in series. A good example is kV-level low-loss SiC rectifiers in high-power pulse width modulated (PWM) motor drives. In this case, Si Schottky diodes easily meet the low-loss requirement but cannot operate near 1 kV because of breakdown in the bulk material in the high-field region near the metal–semiconductor interface. A second example is single SiC switches used at utility distribution levels (~10 kV or more). In this case, the 60-Hz frequency is low enough that solid-state switches are very efficient, but no single Si device can withstand the high peak operating voltages.

Effective use of electrical energy and conservation of energy resources requires high conversion efficiency. Again, SiC devices show superior performance in this aspect because conduction and switching losses are lower if fewer devices are used.

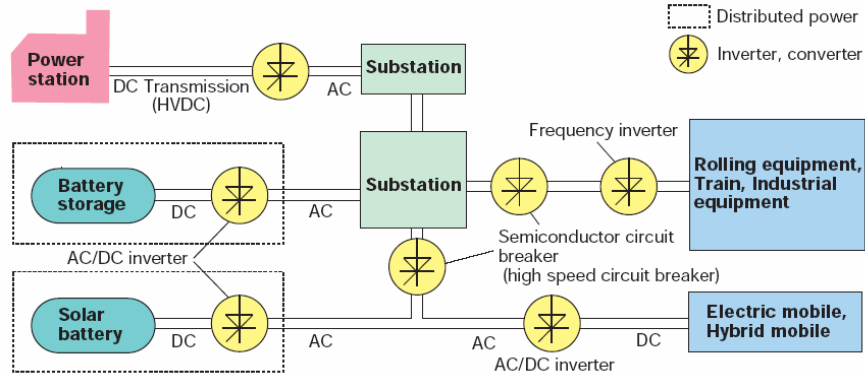
Faster switching frequencies (20–250 kHz) are also available with SiC devices that reduce harmonics in the system and the size of passive components. As a result, less filtering and lower system costs can be expected. On the same note, SiC devices have faster switching times corresponding to faster responses, which contribute to greater protection and compensation schemes.

SiC-based systems are also more compact for two main reasons: (1) the reduced size of a single device resulting from higher possible doping and (2) fewer devices needing to be stacked because of the high possible voltage rating. In addition, the high thermal conductivities of SiC can lower the requirements and simplify the design of thermal management systems. Moreover, an SiC-based power electronics system allows the use of smaller and less expensive passive components—such as isolation transformers, filter inductors, and capacitors—further reducing system volume and cost.

Figure 5.7 shows the future electric power network where the SiC semiconductor may be widely applied.

### 5.5.1 SiC-Based Power Electronics

This section describes the development of SiC wafers and devices. Commercially available products, future products, and prototypes are tabulated; the main manufacturers and research groups are introduced; and the difficulties and obstacles for SiC semiconductor technology are summarized.



**Fig. 5.7. Power network of the future. SiC may be used where yellow inverters are highlighted [4].**

### 5.5.2 Overview of the SiC Wafer Industry

Among the numerous polytypes of SiC, most of the research has focused on 6H-SiC and 4H-SiC. These two polytypes were first commercially available in 1989 and 1993, respectively. Polytype 6H-SiC is slightly more developed and cheaper than 4H-SiC. However, 4H-SiC seems more promising and is particularly suitable for vertical devices because it offers higher carrier mobility in both horizontal and vertical directions, unlike 6H-SiC, which is characterized by anisotropy.

The principal companies producing SiC wafers are listed in Table 5.4, along with a short description of each and a list of products. Cree dominates SiC wafer production with about 85% of the market share. Around 94% of SiC wafer production is in the United States, 4% in Asia, and 2% in Europe. An estimated 250,000 SiC wafers were produced in 2003, and the volume of SiC wafers is projected to reach more than 600,000 units by 2007 [5].

**Table 5.4. Commercially available SiC wafers**

Company	Polytype	Diameter (mm)	Micropipe density (cm <sup>-2</sup> )	Thickness (μm)		Future products
				On-axis	Off-axis	
Cree	4H	50.8	≤5, ≤15	254	368	
		76.2	≤5, ≤15, 16–30, 31–60	350	368	
	6H	50.8	≤5, ≤15	254,140	368	
II-VI	4H	50.8	≤200	400/customer specification		100-mm wafers
	6H	76.2	≤100			
Dow Corning	6H	50.8	≤10, ≤30, ≤100	245–275		100-mm wafers
	6H-substrate	50.8		365–415		
TDI	4H/6H	50.8	≤10			1-cm <sup>2</sup> wafer demonstrated in 2003
INTRINSIC Semiconductor	4H	50.8	≤30	368		100-mm wafers
		76.2	≤50	350		
	6H	50.8	≤30	368		
		76.2	≤50			
	6H-substrate	50.8	≤50	368		
SiCrystal AG	4H	50.8	≤30, ≤100			100 wafers with MPD ≤5 cm <sup>-2</sup> EPI-ready
		76.2	≤10, ≤30			
	6H	50.8	≤100	250		
		50.8	≤10, ≤30, ≤100	380		
6H-substrate	50.8	Almost stress-free				



- **Cree, Inc.** Cree is the world leader in the development and manufacture of SiC. The company was formed in 1987 by a group of researchers from North Carolina State University who were pioneers in the development of single-crystal SiC. Cree's vertical integration throughout the manufacturing process, from crystal growth to device package and test, allows total control over all aspects of the production process.
- **II-VI, Inc.** II-VI acquired the former Litton Airton's SiC activity from Northrop Grumman in late 2001.
- **Dow Corning Corporation.** Dow acquired the bulk SiC business from Sterling Semiconductor, a former subsidiary of Uniroyal Technology Corporation that manufactures SiC wafers and devices, in 2002. Dow Corning brought together its various wide bandgap semiconductor activities under a new business unit called Dow Corning Compound Semiconductor Solutions, located in Midland, Michigan, in September 2003.
- **TDI, Inc.** TDI was founded in Gaithersburg, Maryland, in 1997. The company is a privately owned developer and manufacturer of compound semiconductors. In 2003, it announced a significant step in continuing development of new SiC power electronic products and demonstrated a 1-cm<sup>2</sup> SiC diode chip. The chip is a 4H-SiC Schottky diode fabricated to block 300 V and capable of forward currents of up to 300 A. The chip was fabricated based on a 4H-SiC wafer with defect density substantially reduced by proprietary defect healing technology developed at TDI. This technology converts standard commercial SiC wafers into a product with an extremely low density of micropipes.
- **INTRINSIC Semiconductor.** Established in June 2002, INTRINSIC is a privately held company focusing on materials and device technologies based on SiC and GaN. It acquired Bandgap Technologies, Inc. (Columbia, SC), a manufacturer of SiC wafer products, in August 2004, and Advanced Micro Device Solutions AB (Kista, Sweden), a privately funded company sampling radio-frequency, power, and sensor components based on patented state-of-the-art SiC technology, in October 2004.
- **SiCrystal AG.** SiCrystals' roots date to 1994, when a successful federally funded project on crystal growth of SiC bulk crystals was launched (University of Erlangen–Siemens AG). The company was formed in 1996, and its first wafers were commercially available in 1997. It merged with the Siemens-owned SiC-supplier Freitronics Wafer GmbH & Co. KG in spring 2000. The location of the company is Erlangen in the northern part of Bavaria in Germany.
- **Toyota Central R&D.** Toyota Corporation is researching the feasibility of using SiC in automotive applications. Toyota has developed a new processing technique called repeated-A-face (RAF) that has the potential to increase the yield from wafers by decreasing the number of defects. The company is located in Japan.

High-power devices require a large-area die (>1 cm<sup>2</sup> for megawatt switching) and low-defect-density, large-diameter wafers for higher yield. However, commercial SiC has been limited by the high density of defects (micropipes, dislocations, misoriented blocks, mosaicity, strain, intrinsic point defects, and foreign polytype inclusions). Micropipes are the main obstacles for growing viable large wafers. Micropipes are screw dislocations with open cores that propagate in the growth direction all the way to the surface, appearing as holes. These hence propagate into the epilayer, causing inhomogeneity, low forward current, and low manufacturing yield. At present, commercially available wafers are at 2 in. (50.8 mm), 3 in. (76.2 mm), or 4 in. (100 mm) with 5–10 micropipes per square centimeter. This value is too large, allowing active areas of just a few square millimeters and few large devices on a single wafer. A 2-in. wafer with fewer than 5 micropipes per square centimeter could allow a device area of 10 mm<sup>2</sup>. The best allowable active area is about 20 mm<sup>2</sup> presently, still much less than needed for high-current applications. Recently, 4-in. commercial SiC wafers have been introduced. It is necessary to go to higher wafer sizes with fewer micropipes to be able to produce power devices that can handle high currents.

### 5.5.3 Commercially Available SiC Devices and Research Activities

As discussed previously, many devices have been proposed for SiC, but only SiC Schottky diodes have been commercially available since 2001. The main suppliers include Cree, Rockwell, Advanced Power Technology, SemiSouth, Infineon, and IXYS, as summarized in Table 5.5.

**Table 5.5. Commercially available SiC devices**

Company	Product	Voltage rating (V)	Current rating (A)	Packaging
Cree	Schottky diode	300	12, 20	TO-220, TO-247
		600	1, 4, 6, 10, 20	TO-220, TO-247, DPAK, D2PAK
		1200	5, 10, 20	TO-220, TO-247
APT	Schottky diode	600	4, 6, 10, 20	D2, TO-220, TO-247, TO-254, TO-257, SOT-227
		1200	5, 10, 20	D3, TO-220, TO-247, TO-254, SOT-227
	IGBT combi	600	49, 27	TO-258, TO-247, TO-254
		1200	20	TO-247, TO-254
Rockwell	Schottky diode	1200	7.5	TO-220
Infineon	Schottky diode	600	2, 4, 5, 6, 8, 10, 12	TO-220, TO-252, TO-263
SemiSouth	Schottky diode	600	6	TO-220
	JFET	600	2	TO-257
SEME LAB	Schottky diode	600/1200	5	
	Dual diode	300	2×10	TO-257
IXYS	Schottky diode	600/1200		

Some prototypes (future products) developed by manufacturers are listed in Table 5.6. SemiSouth is beginning to provide SiC JFETs in 2005. SiCED and Rockwell have also developed some prototypes. All the other devices are still under development. Many prototypes have been developed for SiC MOSFETs. The situation looks promising for SiC MOSFETs to enter the market following SiC JFETs. Cree expects to introduce commercial SiC MOSFETs in 2006. Compared with these unipolar devices, development of bipolar devices has been slow, mainly because of the relative complexity and difficulty of device processing.

Besides these companies, some agencies (federal or non-profit) and universities are supporting and conducting research on SiC materials and devices. Detailed information can be found in Table 5.7.

**Table 5.6. Prototypes (future products) developed by manufacturers**

Company	Device	Rating	Others
Cree	MOSFET	10 kV/20 A	Future objective: 10 kV/110 A for module 10–20 kV IGBT
	PiN diode	10 kV/50 A	
	Module (MOSFET/Schottky diode)	1200 V/50 A	
Rockwell	Schottky diode	1200 V/30,50 A, 600 V/30,50 A	Plans for 2005
	JFET	1200 V/15 A, 600 V/25 A	
	MOSFET	1200 V/10 A, 600 V/12 A	
SiCED	(Si IGBT/SiC Schottky diode)	1200 V/25 A, 1700 V/50 A	Potential to 12 kV
	Bipolar diode	4500 V/2.2 A, 1000 V/7 A	
	VJFET	1800 V/7 A, 3500 V/3 A	
	Cascode (SiC VJFET/Si MOSFET)	1500 V/3 A, 600 V/3 A	
	MOSFET	1200 V, 3000 V	
GE	VJFET module	4500 V/15 A	
	MOSFET	1200 V/6 A	

**Table 5.7. Present research in agencies and universities**

Agency/ university	Programs	Contacts
DARPA	<p>Wide bandgap semiconductor technology (WBG) is under Microsystems Technology Office (MTO). It has two branches—High-Power Electronics (HPE) and RF/Microwave/Millimeter-wave Technology (RF).</p> <p>HPE: Revolutionize high-power electrical energy control, conversion, and distribution by establishing a new class of solid state power switching transistors employing wide bandgap semiconductor materials.</p> <p>RF: Enable new RF applications and capabilities through the development and exploitation of the material, device, and circuit properties of wide bandgap semiconductors.</p>	<p><a href="http://www.darpa.mil/mto/wbg/">http://www.darpa.mil/mto/wbg/</a>  HPE: Sharon Beerman-Curtin  (571) 218-4935 (phone)  (703) 696-2206 (fax)  sbeermann-curtin@darpa.mil  RF: Dr. Mark Rosker  Phone: (571) 218-4507  Fax: (703) 696-2206</p>
NASA	<p>National Aeronautics and Space Administration (NASA) Glenn (known as NASA Lewis prior to 1999) has long been a leading driver of SiC technology, as it was one of the first U.S. government agencies to fund and carry out SiC research. It focuses on developing the base crystal growth and device fabrication technologies necessary to produce a family of SiC electronic devices and circuits. NASA Glenn sponsors research through contracts to industry and grants to universities.</p>	<p><a href="http://www.grc.nasa.gov/WWW/SiC/index.html">http://www.grc.nasa.gov/WWW/SiC/index.html</a>  Sensors &amp; Electronics Branch (RIS)  Lawrence G. Matus, Chief  (216) 433-3560  Lawrence.G.Matus@nasa.gov</p>
NIST	<p>The National Institute of Standards and Technology (NIST) has a Power Device and Thermal Metrology project under the semiconductor electronics division. It develops (1) electrical and thermal measurement methods and equipment in support of the development and application of advanced power semiconductor devices and (2) advanced thermal measurements for characterizing integrated circuits (ICs) and devices. Now, it is conducting research in the following areas:</p> <ul style="list-style-type: none"> <li>Performance, reliability, and application characterization for DARPA—wide bandgap—HPE devices and module packages</li> <li>Metrology for mapping SiC power bipolar device degradation</li> <li>Metrology for nondestructive switching failure</li> <li>Circuit simulator models for SiC power switching devices</li> <li>Thermal metrology for power semiconductor package and cooling system</li> <li>High-speed thermal image microscopy for on-chip temperature</li> </ul>	<p><a href="http://www.eeel.nist.gov/812/33.htm">http://www.eeel.nist.gov/812/33.htm</a>  Allen R. Hefner, Ph.D.  Phone: (301) 975-2071  Fax: (301) 948-4081  Hefner@SED.EEEL.NIST.GOV</p>
AFRL	<p>The Propulsion Directorate managed the technical effort that culminated in the commercial transition of this SiC power device. These devices are for Air Force’s More Electric Aircraft, such as electromechanical actuator motor drives. Other applications include motor drives for fuel pumps, power modules, solid-state circuit breakers, radiation-tolerant power management and distribution for space platforms, and integrated radar power supplies.</p>	<p><a href="http://www.afrl.af.mil/">http://www.afrl.af.mil/</a>  Dr. J. Scofield,  (937) 255-5949  afrl.pa.dl.all@wpafb.af.mil</p>

**Table 5.7. (continued)**

Agency/ university	Programs	Contacts
EPRI	<p>In 2004, the Electric Power Research Institute (EPRI) produced a new SiC switch (1 cm<sup>2</sup>) twice as large as any built earlier, with about 100 times the current rating (1750 V, 250 A, 250°C, manufactured by Cree). Over many years, funding for SiC research has been provided through DARPA and the Department of Defense (DOD). EPRI/DARPA Post program is “Silicon Megawatt Electronics.” It includes the research with development and packaging of SiC power GTOs, JFETs, PiN junctions, as well as GaN thyristors and MOSFETs.</p>	<p><a href="http://www.epri.com/">http://www.epri.com/</a>  <a href="http://www.mse.ufl.edu/~spear/mwe_init_rev/">http://www.mse.ufl.edu/~spear/mwe_init_rev/</a></p>
ORNL	<p>Oak Ridge National Laboratory (ORNL) is working on system-level studies of SiC devices in hybrid electric vehicle applications. The objective is to develop experimental simulation tools for wide bandgap semiconductor-based power devices with a focus on SiC in relevant transportation applications. Recently, ORNL has worked on a 55-kW Si IGBT-SiC Schottky diode hybrid inverter and a 7.5-kW SiC JFET-SiC Schottky diode all-SiC inverter. The test results of the hybrid inverter showed up to 30% reduction in losses resulting from the superiority of the SiC Schottky diodes. The testing of the all-SiC inverter, on the other hand, showed the need for more research on the JFETs.</p>	<p>Burak Ozpineci            Phone: (865) 946-1329            Fax: (865) 946-1262  <a href="mailto:ozpinecib@ornl.gov">ozpinecib@ornl.gov</a>            Leon M. Tolbert</p>
ONR	<p>Office of Naval Research (ONR) has a semiconductor devices program that investigates electronic properties of wide bandgap and Si-based semiconductors and novel devices. It is focused on novel high-power microwave and switching devices for broadband radar, EW, communications, and multifunctional systems applications and for high-power control applications.</p>	<p><a href="http://www.onr.navy.mil/sci_tech/information/312_electronics/prog_semi.asp">http://www.onr.navy.mil/sci_tech/information/312_electronics/prog_semi.asp</a>            Program Officer            (703) 696-0240  <a href="mailto:312_SD@onr.navy.mil">312_SD@onr.navy.mil</a></p>
Army- ManTech	<p>Army-ManTech provides the capability to manufacture SiC high-temperature power devices and modules. This program will develop manufacturing technology in parallel with material development for SiC base material (wafers and epi layers) as well as SiC devices and modules. It is designed to (1) increase SiC base material throughput by 3× and scale size to a 4-in. diam. and (2) increase device fabrication throughput for low-voltage (LV, 1.2–2 kV) diodes and switches and high-voltage (HV, 4–15 kV) diodes by 3× over baseline. Cost reduction goals from current baseline for final production of SiC devices are from \$1.20/A to \$0.30/A for LV diodes, and from \$5.00/A to \$.75/A for LV switches and HV diodes. Individual SiC die current ratings will range from 50–150 A for LV diodes, 5–100 A for LV switches, 25–100 A for HV diodes, and 8–40 kA for HV pulse switches. Base material production, device manufacturing, and packaging technology for high-temperature and power modules are currently at MRL 3/4 and will be matured to MRL6 or greater. SiC devices/modules are at TRL 5 for lower current and at TRL 4 for higher current applications.</p>	<p><a href="http://www.armymantech.com/tchome5.htm">http://www.armymantech.com/tchome5.htm</a>            Dimos Katsis            (301) 394-0926  <a href="mailto:DKatsis@arl.army.mil">DKatsis@arl.army.mil</a></p>

**Table 5.7. (continued)**

Agency/ university	Programs	Contacts
MCNC-RDI	MCNC-RD can develop electronic components or devices, devise novel semiconductor or insulating materials, or analyze an available material, and they can also provide analytical, fabrication, and packaging services. They also provided packaging of GaN thyristors and MOSFETs in DARPA-EPRI joint program —Megawatt Solid-State Electronics	Rebecca Switzer (919) 485-2666 listen@rti.org
Purdue	Purdue’s Wide Bandgap Research group is working on processing science and design of power switching devices. More information can be found at the following link: <a href="http://www.ecn.purdue.edu/WBG/">http://www.ecn.purdue.edu/WBG/</a>	Jim Cooper (765) 494-3514 cooperj@ecn.purdue.edu <a href="http://www.ecn.purdue.edu/WBG/MURI/">www.ecn.purdue.edu/WBG/MURI/</a>
RPI	RPI is working on developing new device concepts and circuit models for high-voltage power devices and integrated circuits, in process research of Si and wide bandgap compound semiconductors, and process integration of UL Si metallization. Ongoing projects: High-voltage Schottky barrier diode on CVD single-crystal diamond GaN power devices 4 H-SiC–based BJTs and Darlingtons for power device applications 4H-SiC–based high-voltage JBS and JFETs 4H-SiC epi-emitter BJTs and Darlingtons 4H-SiC– based high-voltage rectifiers Silicon IGBT/MPS power device Silicon DMOSFET/MPS and integrated current sensors Si lateral trench RESURF power MOSFETs 4H-SiC–based trench DMOSFETs and MOS studies	<a href="http://www.eng.rpi.edu/soe/directory_faculty_details.cfm?facultyID=chowt">http://www.eng.rpi.edu/soe/directory_faculty_details.cfm?facultyID=chowt</a> T. Paul Chow Phone: (518) 276-2910 Fax: (518) 276-8761 chowt@rpi.edu
Auburn	The Center for Space Power and Advanced Electronics (CSPAЕ) under the Space Research Institute is working on high-temperature SiC device technology and high-temperature electronics/ packaging. Goal: to work with industry to provide the first SiC thyristors, MOSFETs and SBDs Objectives: to team with industry partners to produce: • 1-kV, 5-A MOSFETs • 1-kV PiN and Schottky diodes • Confirm diodes’ radiation stability and 350°C, 10-h durability Participants & Customers: Cree, Inc., Sterling Semiconductor, Inc., SemiSouth, Inc., Boeing Phantom Works, NASA-GRC, DoD (AFRL, ONR, DARPA)	<a href="http://hyperoptic.spi.auburn.edu/cspae.htm">http://hyperoptic.spi.auburn.edu/cspae.htm</a> Drs. J. Williams, C.C. Tin (Phys) Dr. Wayne Johnson (ECE) Space Research Center 231 Leach Center Auburn University, AL 36849 Phone: (334) 844-5894 Fax: (334) 844-5900

**Table 5.7. (continued)**

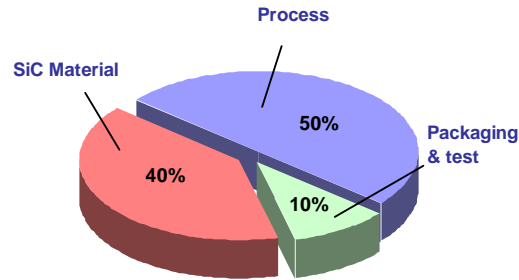
Agency/ university	Programs	Contacts
Carnegie Mellon	Carnegie Mellon is working on SiC growth and characterization: Growth of SiC Crystal structure of perfect SiC polytypes Extended defects in SiC boules and wafers	<a href="http://neon.mems.cmu.edu/skowronski/SiC%20front.htm">http://neon.mems.cmu.edu/skowronski/SiC%20front.htm</a> Marek Skowronski mareks@cmu.edu Phone: (412) 268-2710 Fax: (412) 268-3113
University of Arkansas	The University of Arkansas collaborates with NIST and NASA Glenn. The semiconductor device group project is doing modeling SiC devices for power supply performance evaluation. Specific project objectives are Characterize the JFET, BJT, integrated BJT Darlington pair, and GTO SiC devices Design and develop JFET, BJT, integrated BJT Darlington pair, and GTO models Validate all SiC power device models against actual device measurements Demonstrate and validate SiC power device models in key power electronic applications	<a href="http://enr-118-02.eleg.uark.edu/sic/">http://enr-118-02.eleg.uark.edu/sic/</a> Dr. Alan Mantooth Phone: (479) 575-4838 Fax: (479) 575-7967 mantooth@enr.uark.edu
University of Tennessee	The University of Tennessee will optimize system development of SiC-based switches. It will develop device models, novel circuit, and gate-drive topologies. Collaborator: ORNL and several small businesses	<a href="http://www.ece.utk.edu/~tolbert/sic.htm">http://www.ece.utk.edu/~tolbert/sic.htm</a> Leon M. Tolbert (865) 974-2881 Tolbert@utk.edu
Mississippi State University (MSU)	MSU scientists are teaming up with a Starkville-based company to develop light, rugged, high-density power electronics for missile defense applications in outer space. SemiSouth Laboratories, Inc., has received a two-year, \$500,000 contract from the U.S. Missile Defense Agency to manufacture and transfer SiC integrated circuit technology provided by MSU for space-based power and sensor applications. MSU will provide its extensive expertise in epitaxial growth, process development, and material characterization in the SemiSouth project.	<a href="http://www.ur.msstate.edu/news/stories/2004/siliconcarbideresearch.asp">http://www.ur.msstate.edu/news/stories/2004/siliconcarbideresearch.asp</a> Yaroslav Koshka (662) 325-2411 Jeff Casady (662) 324-7607 or 769-0962
University of Florida (UF)	UF's processing of wide bandgap semiconductor materials—GaN, SiC and related compounds—is funded by DARPA/EPRI, the National Science Foundation (NSF), and Sandia National Laboratories. Some of the current projects are Ultra-high-temperature rapid thermal annealing for implant activation in GaN and SiC. High-rate, low-damage etching of SiC using ICP NF <sub>3</sub> plasmas.	<a href="http://www.mse.ufl.edu/~spear/">http://www.mse.ufl.edu/~spear/</a> Dr. Stephen J. Pearton Phone: (352) 846-1086 Fax: (352) 846-1182 spear@mse.ufl.edu
Penn State	One research focus of the Electronics Research Group at Penn State is SiC device technology. The group mainly works on the SiC power MOSFET process.	<a href="http://jerg.ee.psu.edu/index.htm">http://jerg.ee.psu.edu/index.htm</a> Thomas N. Jackson tnj1@psu.edu Phone: (814) 863-8570 or (814) 865-1267

#### 5.5.4 Challenges for SiC Semiconductor Technology

Although Si semiconductor technology is highly developed, the fabrication of SiC semiconductors is not a one-to-one duplication of Si semiconductors; and the implementation of SiC semiconductors is not chip-to-chip replacement of Si semiconductors. New device structures, processing technology, and electric circuits are required in order to take advantage of SiC semiconductors. Therefore, a series of issues need to be resolved before SiC devices gain widespread use in power electronics applications.

## Cost

High cost is one barrier limiting the development of SiC devices. Currently, the price of SiC devices is 5–10 times that of Si devices. Cree has projected that the best SiC devices will be twice as expensive as their Si counterparts. As shown in Fig. 5.8, 40% of the total cost of SiC devices comes from the SiC material, 50% from the process, and 10% from packaging and testing. Thus SiC materials and processing technology are critical factors that dominate the cost of SiC devices and influence their market prospects.



**Fig. 5.8. Typical cost breakdown for SiC devices [6].**

## Material availability and quality

Currently, 3-in. SiC wafers and 2-in. semi-insulating wafers are available, but the breakthrough will be the emergence of 4-in. wafers that are compatible with standard semiconductor tool sets. Micropipe density is the main limitation on the size of the SiC wafer. The best-quality commercially available wafer has a micropipe density of less than  $5 \text{ cm}^{-2}$ . This allows an active area of about  $20 \text{ mm}^2$ . However, a micropipe density of less than  $1 \text{ cm}^{-2}$  is required to realize devices with current ratings of larger than 100 A. Currently, all industrial-standard wafers are produced by an approach called physical vapor transport, which will also be used for future 4-in. wafers. But this technology is far from mature. It still presents problems such as direction control of the gas-phase composition and control of dopant feeding that degrade the quality of SiC wafers [3].

## Device design and fabrication

Presently two techniques are used to fabricate SiC wafers, chemical vapor deposition (CVD) and repeated-A-face.

- **Chemical Vapor Deposition**

The principle of the CVD process is to transport reactive compounds (precursors) by a carrier gas to a hot zone where the precursors will thermally decompose into radicals of two or more atom “seeds,” which may diffuse down onto a substrate and produce an epitaxial film [7] Epitaxy is a thin, high-quality layer or layers of different composition such as abrupt Pin junctions. The epitaxial films are stacked to produce a wafer. All commercially available SiC devices are produced using this technique.

- **Repeated-A-Face (RAF)**

RAF was introduced in 2004 by Toyota Central R&D. Toyota’s goal is to develop a new way of making SiC crystals that leads to the production of larger and more reliable wafers. RAF builds on CVD by adding layering epitaxial films in three dimensions. An epitaxial film is

produced on the substrate in the x-axis, and then the substrate is positioned to add a film in the y-axis, and finally the substrate is positioned to add a film in the z-axis. This technique is said to reduce the number of wafer defects by a factor of 3 [8]. Unfortunately, no commercially available SiC devices are produced using this technique.

All the basic process steps of SiC devices have been demonstrated, but many problems remain to be dealt with. First, to minimize parasitic substrate resistance in a SiC device and maximize its current density, a high doping concentration is desirable. Also, high-temperature annealing at 1500–1700°C is required. Second, the SiC-SiO<sub>2</sub> interface is of poor quality, resulting in poor channel mobilities and low transconductance. Third, ohmic contact requires high-temperature annealing, and its stability at high temperatures needs analysis. Fourth, surface charges and surface states of SiC have different properties. It is critical to use different control strategies to suppress the breakdown near the surface [9]. On the other hand, most of the device structures tried so far were copied from Si technologies. Although these structures have been proven in Si, they are not necessarily applicable to SiC. New device structures may be developed to fit SiC materials.

### **Device packaging technology**

High-temperature, high power density packaging techniques are required to take full advantage of SiC capabilities. The currently available packaging techniques are for applications of Si devices, which generally have a power density limit of 200 W/cm<sup>2</sup> and/or a use temperature of less than 125°C, while an SiC device may require a power density of 1,000 W/cm<sup>2</sup> and /or a use temperature of 250°C or more.

### **Application**

Although SiC devices will be substitutes for Si devices, it is impossible to do a chip-to-chip replacement. Device tests and modeling are needed. New circuit, gate drive, microprocessor, and passive components are needed to take advantage of SiC devices and adapt them to harsh application environments such as high temperatures.

## **5.6 GaN Devices**

Figure 5.9 illustrates a review from Table 5.1 of the electronic properties of GaN-based devices. These properties give GaN-based systems the following advantages:

- High power density
- Multi-octave bandwidth
- High efficiency
- Linearity

Therefore, the markets for laser printing, optical storage, high-brightness LEDs, general illumination, and wireless base stations can clearly benefit from GaN-based devices. Other GaN device markets that have yet to be developed, or are in their infancy, are medicine, memory applications, and power electronics devices (see Table 5.8).



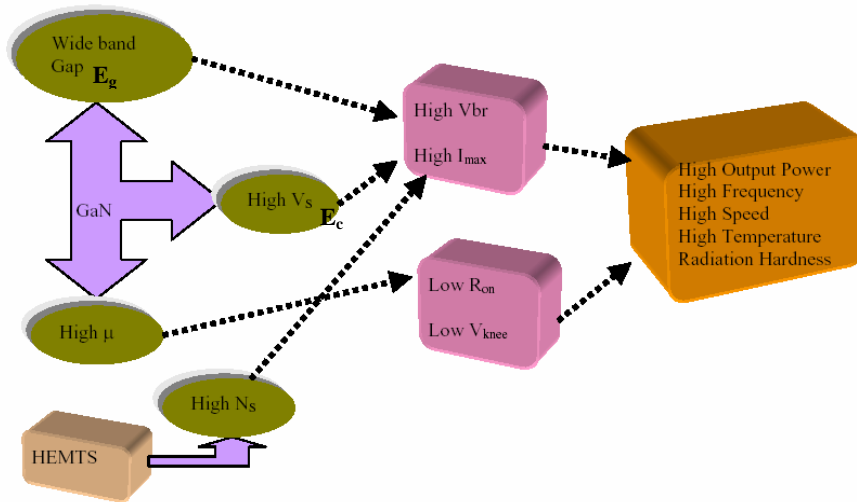


Fig. 5.9. Electronic properties of GaN-based devices.

Table 5.8. GaN device market [10]

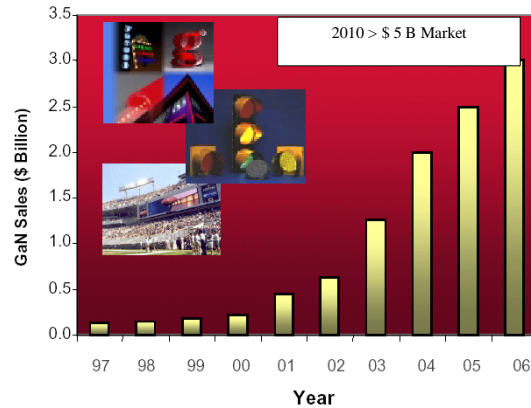
Optical device applications	Lasers	LED	UV detectors
	Optical storage	Traffic lights	Flame detectors
	Laser printers	Video displays	Analytical equipment
	Military	Miniature lamps	Pollution monitor
	Medical	Automotive lamps	Ozone monitor
		General illumination	
Electrical device applications	Power transistors	Integrated circuits	
	Cellular base station	Microwave circuits	
	Power electronics converters	Cellular infrastructure	
	Radar and microwave		

### 5.6.1 Overview of GaN Semiconductor Technology

The advantages of SiC over Si have been investigated for many years. It is only in the past decade that serious attention has been given to other wide bandgap semiconductors for use in research.

While so far GaN has been explored for optoelectronic and radio frequency applications, it also offers significant advantages for power-switching devices because of the availability of band engineering in III-nitride materials. In fact, the ongoing development of GaN-based devices for optoelectronic and RF applications allows the natural extension of this technology into the power electronics field. In comparison with SiC, the availability of band engineering for III-nitride materials allows device operation at higher speed and at much higher current density. Recently, some AlGaIn/GaN structures have been proposed that are useful for several hundred volts of power switching [11–14].

GaN-based semiconductor materials have attracted a great deal of interest in power electronics devices. Figure 5.10 shows the commercial sales opportunities for GaN-based devices.



**Fig. 5.10. Commercial opportunities for GaN [15].**

The main GaN research groups in the United States are

- The University of South Carolina
- Sandia National Laboratories, New Mexico
- The University of Nebraska, Lincoln
- University of Florida, Gainesville
- Microelectronics Center of North Carolina
- The University of Michigan, Ann Arbor
- Defense Advanced Projects Research Agency
- Power Electronics Branch, Naval Research Laboratory Washington, D.C.

## 5.6.2 Material Technology of GaN

### 5.6.2.1 GaN wafers

#### Availability of commercial wafers

Si and GaAs semiconductor wafers are available in diameters of up to 15 cm and variable thicknesses of from 225 to 675  $\mu\text{m}$ . Because of their abundance, they are inexpensive, less than \$100/US each. GaN and SiC wafers are not abundant; therefore, they are expensive, in the \$2000–\$3000/US range. Even though the prices of SiC and GaN wafers are high, mass production probably will bring them closer to Si and GaAs wafer price levels.

GaN wafers generally come in two forms: GaN on SiC or GaN on sapphire. The former is suitable for power device applications and the latter for LEDs and other optical applications. Recently, a company claimed to have produced the first true bulk GaN, but no commercial products are available yet. The diameters and the thicknesses of the commercially available wafers are small at 5 cm in diameter and up to 25  $\mu\text{m}$  in thickness [16].

#### Defects

It was found that a serious deficiency of nitrogen atoms was induced on the GaN and AlGaIn surfaces during various kinds of device processing, such as high-temperature annealing, plasma cleaning, plasma etching and deposition of metal and insulation. This resulted in the introduction of N-vacancy-related deep levels near conduction band, which was responsible for excess leakage of Schottky gates and drain current collapse in AlGaIn/GaN heterostructure field effect transistors [17,18].

### 5.6.2.2 GaN substrate

Improved GaN film can be grown using molecular beam epitaxy (MBE) and metal organic vapor phase epitaxy (MOVPE) or metal organic chemical vapor deposition (MOCVD) techniques. GaN substrates with large enough diameters do not exist for growing GaN channels; the largest GaN substrates obtained so far are  $1.7 \times 1$  cm [19]. Sapphire and SiC are the most popular substrate materials used today. Sapphire is cheaper for GaN growth than SiC. But the low thermal conductivity presents a serious challenge for packaging of high-power devices. Long-term reliability may be an issue because of thermally induced stress on the contacting pads, which also serve as the heat-conducting path. On the other hand, SiC has lower lattice mismatch with GaN or AlN and ten times higher thermal conductivity [20]. Other substrates such as LiAlO<sub>2</sub> [21], LiGaO<sub>2</sub> [22], Si [23], and AlN are being investigated.

### 5.6.2.3 GaN material challenges

GaN faces several challenges in the effort to produce semiconductor materials for power electronics devices, which are identified below.

**Substrates that are difficult to produce:** Sapphire substrates, which are the most common, have a severe lattice mismatch with GaN, which leads to defects in the GaN layer. SiC used as a substrate has a much better lattice match, but it has different thermal expansion properties from GaN, which leads to cracking. The ideal substrate to use would be bulk GaN crystals. Unfortunately, large single crystals of GaN are extremely difficult to make, requiring high temperatures (1800°C) and pressure (2 Gpa).

GaN does not have a native oxide, which is required for MOS devices. For GaN, more studies are under way to find a suitable oxide; without it, GaN MOS devices are not possible.

In the nucleation technology of low-Al-content AlGaIn layers, it is necessary to “calibrate” each new boule of sapphire, to find appropriate nucleation conditions. The high-Al content nucleation, however, seems to be largely insensitive to the surface finish of the substrate.

**High-temperature material growth process:** It was found that a serious deficiency of nitrogen atoms was induced on the GaN and AlGaIn surfaces during various kinds of device processing, such as high-temperature annealing, plasma cleaning, plasma etching, and deposition of metal and insulation.

**Defect proneness:** Many failure mechanisms in GaN can shorten the mean time between failures. Other failure mechanisms are related to trapping of hot electrons in the buffer and donor layer adjacent to the channel or on the surface. The large lattice mismatch and difference in thermal expansion coefficient between substrate and GaN films results in a high degree of stress; therefore, a high density of defects is generated at the substrate/epitaxial film interface. These defects propagate into the growing film. Besides, additional work is still required to solve surface and interface-related problems such as the gate leakage and trapping effects.

**Low hole mobility:** The hole mobility in GaN is approximately 200 cm<sup>2</sup>/V/s. The electronic property of p-GaN constitutes the poor base currently, resulting in a high base resistance caused by a large contact resistance and a high sheet resistance.

**Deep donors and acceptors:** The undoped GaN is n-type and usually has a high free electron concentration ( $10^{17}$ — $10^{18}$  cm<sup>-3</sup>) at room temperature. The dominant donor has not been identified, and there is an intrinsic defect (nitrogen vacancy). The resistivity of the material can be increased dramatically by the addition of group II atoms; these elements introduce deep acceptors that compensate the native donors.

### 5.6.3 GaN Power Devices

GaN and related materials (especially AlGaN) have recently attracted much interest for applications in high-power electronics capable of operation at elevated temperatures and high frequencies. The AlGaN system offers numerous advantages, including these:

- Wide bandgap
- Good transport properties
- Availability of heterostructures (particularly AlGaN/GaN)

AlGaN led to rapid progress in the realization of a broad range of GaN electronic devices. A direct comparison of GaN PiN and Schottky diodes fabricated on the same GaN wafer showed higher reverse breakdown voltage for the former (490 V versus 347 V for the Schottky diodes), but lower forward turn-on voltages for the latter (~3.5 V versus ~5 V for the PiN diodes). The forward I-V characteristics of the PiN diodes show behavior consistent with a multiple recombination center model. The reverse current in both types of diodes was dominated by surface perimeter leakage at moderate bias. Finally, all of the fabricated devices showed negative temperature coefficients for reverse breakdown voltage, which is a clear disadvantage for elevated temperature operation [24–27].

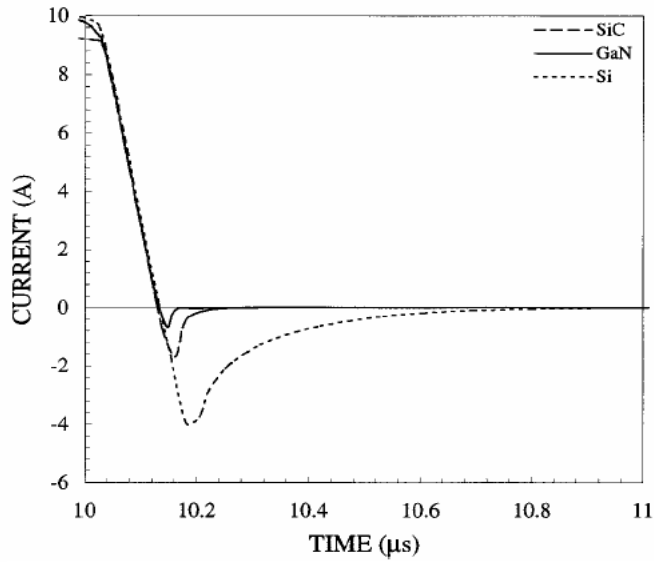
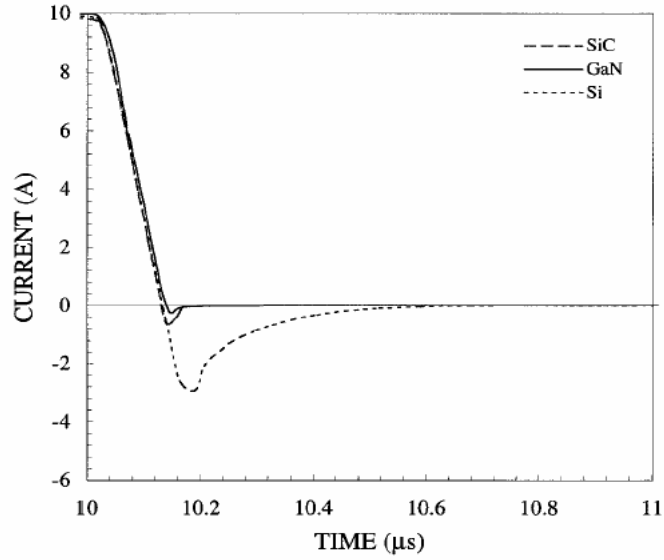
The comparison of GaN Schottky diodes with SiC Schottky and Si PiN diodes at similar blocking voltages shows a performance advantage for the GaN Schottky diode because of its lower reverse recovery current and consequent lower switching loss that is independent of the operating temperature. The switching speed and losses of GaN Schottky diodes have been shown to be slightly better than those of similarly rated SiC diodes [25]. On the other hand, because of its wider bandgap, the GaN Schottky diode's forward voltage drop is much higher than that of both the Si PiN and SiC Schottky diodes. In the literature, GaN Schottky diodes rated at up to 2 kV [24] and GaN PiN diodes rated at up to 9.7 kV [25, 26] have already been demonstrated; however, 4.9-kV SiC Schottky diodes [27] and 19.2-kV PiN diodes have also been demonstrated. Figure 5.11 shows some improvement for GaN technology over other semiconductor technology in reverse recovery.

Building bipolar devices in GaN is challenging because of its direct band structure and consequently shorter carrier lifetimes. Note that bipolar devices are required for the high-voltage blocking capability required for utility application; therefore, GaN material is not a promising material for high-voltage power device applications.

### 5.6.4 Comparison between GaN and SiC

The performance of GaN power devices is similar to the performance of SiC power devices; however, GaN has several disadvantages compared with SiC:

- GaN does not have a native oxide, which is required for MOS devices. SiC uses the same oxide as Si (SiO<sub>2</sub>). For GaN, more studies are under way to find a suitable oxide; without it, GaN MOS devices are not possible.
- With the present technology, GaN boules are difficult to grow. Therefore, pure GaN wafers are not available; instead GaN wafers are grown on sapphire or SiC using HVPE-hydride vapor phase epitaxy [24–28]. Even with HVPE, thick GaN substrates are not commercially available. As a consequence, GaN wafers are more expensive than SiC wafers. Although significant progress has been achieved in GaN-based high-power/high-frequency electronic devices, additional work is required to solve surface- and interface-related problems such as gate leakage and trapping effects.



**Reverse recovery performance of Si, 6H-SiC, and GaN 700 V diode at (a) room temperature and (b) at 623 K.**

Reverse recovery performance of 700 V diodes.

Material	300 K			473 K		
	$I_{rr}$ (A)	$t_{rr}$ (ns)	$E_{off}$ ( $\mu$ J)	$I_{rr}$ (A)	$t_{rr}$ (ns)	$E_{off}$ ( $\mu$ J)
Si	2.93	275	53.3	3.96	359	96.1
6H-SiC	0.6	35.1	0.511	1.71	70.4	3.36
GaN	0.24	64.4	0.671	0.65	31.1	1.03

**Fig. 5.11. Reverse recovery performance [27].**

- Another substantial disadvantage of GaN compared with SiC is its thermal conductivity, which is only one-fourth that of SiC. This property is especially important in high-power, high-temperature operation because the heat generated inside the device needs to be dissipated as quickly as possible. The higher the thermal conductivity, the more quickly the heat is dissipated. Growing GaN on SiC wafers increases the overall thermal conductivity, but it still does not reach the performance of SiC. Thus for power applications, SiC devices are preferred.
- High-voltage bipolar devices are not promising for GaN power devices because of GaN's direct band structure and short carrier lifetimes. Therefore, IGBTs and PiN diodes will be out of the question in the near future. The only possible devices are MOSFETs and Schottky diodes. Bipolar devices will be needed if truly high-power semiconductor devices (>10 kV, >100 A) are to be developed.

## 5.7 Diamond Devices

Diamond is intrinsically suited for high-speed, high-power, and high-temperature (up to 1000°C) operation. It is viewed as the ultimate semiconductor. However, diamond faces significant processing hurdles that must be overcome before it can be commercially used for power electronic devices.

The main advantages of diamond-based devices for power utilities can be summarized as follows:

- 5 to 10 times higher current density than current devices
- High reverse blocking voltage
- Low conduction losses and fast switching speed
- Capability to withstand high radiation levels
- Higher-temperature operation and superior heat dissipation
- Larger power flow and voltage control devices
- Dramatic reduction in complexity (improved reliability)
- Increased reliability and reduced cost
- Reduced or eliminated need for transformation and voltage upgrades
- Reduced capital costs
- Reduced or eliminated snubber circuits (reduction in device size)

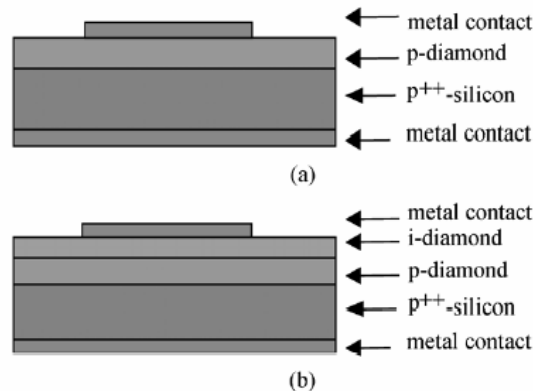
### 5.7.1 Research on Diamond Devices

Presently, most of the diamond research has been in the following areas:

- Micro-patterned diamond micro-tips on films (mold technique)
- Diamond electron field emitter two/three terminal devices
  - Diode: {power diodes, laser diode, self-align gated diamond emitter diode [silicon-on-insulator (SOI) process]}
  - Triode: self-aligned gated diamond emitter triode
- Transistors: diamond field effect transistor
  - Core structure: (CVD diamond)
  - Gate, anode
  - Field emitter geometry
  - Emitter array configuration
- Diamond cathode
- Silicon-on-insulator micro-electromechanical systems
- Vertical and lateral diamond emitter with nanometer-scale (5-nm) diamond tip

The research group at Vanderbilt University has designed, fabricated, characterized, and analyzed diamond-based Schottky diodes fabricated by plasma-enhanced CVD for high-power electronics applications. This vacuum field emission device has a 500-V breakdown voltage and 100-A/cm<sup>2</sup> current density. Diamond devices still do not have significant current carrying capability; the highest demonstrated currents have been less than 1 A. These values are among the highest reported with the polycrystalline diamond-based devices shown in Fig. 5.12. Table 5.9 shows the breakdown voltage and depletion layer of the device. Future devices should block 10–100 kV, conduct more than 100 A/cm<sup>2</sup>, operate at temperatures above 500°C, and switch at frequencies approaching 500 GHz. Devices with higher operating temperatures will enable a large reduction in device count, reducing or eliminating interface circuits and reducing cost significantly.

It is important to note that vacuum field emission devices are not solid state devices as are Si and SiC. The vacuum field emission devices are similar to the vacuum tubes manufactured in the 1950s, which underlines the infancy of this program.



**Fig. 5.12. Diagram of power diode structure: (a) metal semiconductor structure and (b) metal insulated semiconductor structure [29].**

**Table 5.9. Breakdown voltage and depletion layer with doping concentration (boron) [29]**

Doping density (cm <sup>-3</sup> )	V <sub>B</sub> (V)	WM (μm)
1.00E+15	745670	2.13E+02
1.00E+16	7456.7	21.3
1.00E+17	745.67	2.13
1.00E+18	74.567	2.13E-01

The following organizations and research groups have active programs on using diamond for electronics and power electronic applications:

Countries:

- Russia
- Britain
- Japan
- European Union
- Germany
- Switzerland
- United States

Companies (fabrication):

- SI Diamond Technology
- ASEA Brown Boveri (ABB) in Sweden
- DeBeers Industrial Diamonds in England
- QQC
- Norton
- Fraunhofer-CSEM
- Element Six, Ltd. (world leader in the production of all forms of synthetic diamond for industrial use)
- Dynex Semiconductor, Ltd.

Research groups:

- J. L. Davidson and W. P. Kang, Vanderbilt University, Nashville, TN, United States
- Bell Labs, Lucent Technology, United States
- The University of Cambridge, Britain
- D. V. Kerns Olin College of Engineering, Needham, MA
- Hiroshi Kawarada, Waseda University, Japan
- Makoto Kasu, NTT Basic Research Laboratories, Japan
- Greg M. Swain, Michigan State University
- Sheffield Hallam University, Britain
- Diamond Electronics Group based at University College, London (UCL)
- Uppsala University, Sweden

### **5.7.3 Critical Technology Concerns**

There are several concerns with using diamond for power electronic devices. Some of these issues are identified in the following sections.

#### **Diamond synthesis**

Diamond synthesis with different sizes and morphologies is now available with fabrication facilities. The main synthesizing methods are

- High-pressure and high-temperature synthesis [30]
- Shock wave processing [31]
- CVD techniques [32]
- Hot filament CVD (the choice of substrates for growing CVD diamond)
- Nucleation

The diamond material generally possesses defects such as grain boundaries, twins, stacking faults, dislocations, platelets, and inclusions [33, 34]. Moreover, diamonds may contain point defects, which fall into two groups: (1) intrinsic defects resulting from self-interstitials and vacancies and (2) impurity-related defects coming from foreign atoms. Neither natural nor synthetic diamond is completely free of impurities.

#### **Substrate**

The substrate must have a melting point (at the process pressure) higher than the temperature window (1000–1400 K) required for diamond growth. This precludes the use of existing CVD techniques to diamond-coat plastics or low-melting-point metals such as aluminum. It is also



helpful, though not essential, that the substrate be capable of forming carbide. Si has a sufficiently high melting point (1683 K), it forms a localized carbide layer, and it has a comparatively low thermal expansion coefficient. Thus most of the CVD diamond films reported to date have been grown on single-crystal Si wafers. But this is by no means the only possible substrate material. Tungsten and molybdenum display similar virtues and are also widely used as substrate materials.

### **Doping issues**

The doping of diamond with various concentrations of boron allows the electrical properties of a device to be tailored. CVD diamond techniques allow thin layers of diamond to be deposited onto other materials so that the material may be incorporated into electronic devices. However, the close packing and rigidity of the diamond lattice makes doping with atoms larger than carbon atoms difficult. This means that the dopants routinely used to n-dope Si, such as phosphorus or arsenic, cannot easily be used for diamond; therefore, alternative dopants such as lithium are being investigated.

In addition to boron doping, recent work has shown that it may be possible to dope diamond with sulfur. Studies could be performed to see if sulfur-doped polycrystalline diamond acts as an n-type semiconductor at low doping levels. Interesting studies could also be performed by co-doping diamond with more than one dopant. Electrochemical studies could investigate diamond doped with varying quantities of boron, nitrogen, and sulfur.

### **Processing problems**

The possibility of doping diamond and changing it from being an insulator into a semiconductor opens up a whole range of potential electronic applications. However, a number of major problems need to be overcome if diamond-based electronic circuits are to be achieved. Principal among these is the fact that CVD diamond films are polycrystalline and hence contain grain boundaries, twins, stacking faults, and other defects that all reduce the lifetime and mobilities of carriers. Active devices have been demonstrated using homoepitaxially-grown diamond on natural or synthetic diamond substrates; but to date, there have been no corroborated reports of heteroepitaxial growth of device-quality diamond on non-diamond substrates. This remains a major limiting factor in the development of diamond devices. Nevertheless, the effects of grain boundaries and defects upon electronic carriers in the very best polycrystalline diamond films remain to be ascertained. Clearly, this possible route to active diamond devices cannot yet be ruled out.

Another outstanding problem hindering potential diamond electronics is the difficulty in producing n-type doping. P-type doping is relatively straightforward, since the addition of a few percent of  $B_2H_6$  to the CVD process gas mixture is all that is required to incorporate B into the lattice.

One further difficulty that must be overcome if diamond devices are to be realized is developing the capability to pattern the diamond films into the required micron or even submicron geometries. Dry etching using  $O_2$ -based plasmas can be used, but etching rates are slow and the masking procedure complex. Alternative patterning methods include laser ablation or selective nucleation. There are many variants of the latter process, but all involve trying to mask off certain areas of the substrate so as to allow diamond to grow only in selected regions. A typical process scheme involves coating an Si substrate with a thin layer of  $SiO_2$ , which is then patterned using standard photolithographic and dry etching methods to expose areas of Si. The wafer is then ultrasonically abraded, and the oxide layer is stripped in hydrogen fluoride. CVD diamond is then grown, nucleating preferentially on the abraded Si areas rather than on the unabraded areas that were beneath the mask.

## 5.8 Strategic Research Needs in Wide Bandgap Semiconductors

SiC is the most mature technology among the wide bandgap semiconductors and is the best one for near-term utility power electronics applications. Presently, most wide bandgap semiconductor research is focused on improving the quality of the SiC material so that high-current power devices could be possible. In addition to materials research, new SiC power devices are being developed. SiC wafer manufacturing companies, DARPA, the Army Research Lab, and the Air Force are spending significant sums of money on SiC materials research. For utility power electronics, the following types of research on SiC power devices need more attention:

1. **SiC wafer developments:** SiC devices will revolutionize the PE industry once high-current devices are developed. Four-inch wafers must be manufactured to achieve these required currents. CVD and RAF processes cannot produce wafers this size without the necessary defect-free quality. Research in SiC wafer developments is greatly needed to secure SiC devices in power applications.
2. **System-level impact:** SiC devices have superior performance compared with their Si counterparts at the device level. Presently, extensive studies on the system-level impact of these devices at the utility level are not available to quantify the superiority of SiC-based systems. Only after some of these studies are completed will there be a clear picture of how important these devices are to the grid.
3. **High-voltage SiC devices:** Most of the SiC device research focuses on devices with blocking voltages of 10 kV and below with low current ratings. SiC devices can block much higher voltages than Si power devices, and utility applications need high voltage-blocking and high current-carrying capabilities. For this reason, more research is required on high-voltage-blocking (15 kV and higher) SiC power devices with high current ratings (>100 A). SiC companies must be motivated to design and build more utility-compatible power devices.
4. **SiC IGBT:** As explained in the previous chapter, IGBTs are the preferred power devices, but the blocking voltage ratings of Si IGBTs are limited to 6.5 kV and lower. Theoretically, SiC IGBTs can be built to block much higher voltages, and they can replace GTOs in medium-voltage applications. One major problem associated with building SiC IGBTs is the SiO<sub>2</sub> interface. This interface still has structural problems as well as high-temperature-operation problems. More research is required to improve this interface before reliable SiC IGBTs can be built that can be operated at high temperatures.
5. **Packaging of SiC devices:** SiC devices can run at junction temperatures much higher than those of Si power devices; however, they still use conventional Si device packages, which limit their operating temperature. New power device packages need to be developed that can handle SiC devices running at 250°C or above so that the capabilities of SiC power devices can be optimally utilized.

## 5.9 Summary

Wide bandgap devices have great potential to surpass Si in the near future. Most likely, they will be useful for specialized high-power, high-temperature applications such as utility applications, or in high-temperature, high-speed applications (e.g., radar/satellite). However, materials processing is the most important factor involved in enabling the use of wide bandgap materials in mainstream power electronics devices. In summary,

- Si devices continue to dominate the present commercial market.
- Significant system benefits are anticipated for wide bandgap devices; however, there are many material and device challenges for them.
- The technical strategy requires comprehensive development efforts with many industrial and academic partnerships.
- SiC is the best suitable transition material for future power electronics devices for utility applications.
- GaN and SiC power devices have similar performance improvements compared with Si power devices. SiC power devices are at a more advanced stage than GaN power devices. Most of the work being done with GaN is for radio frequency electronics and optoelectronics.
- Diamond is the ultimate material for power devices in utility applications. However, diamond power devices are not expected to be abundant for another 20–50 years.

## **6. SUPPORTING TECHNOLOGIES FOR POWER ELECTRONICS**

After power devices are built in Si, SiC, or any other material, they have to be packaged so that they can be used in power converters. When these power converters are operated, the heat generated because of the losses in the switches has to be dissipated using a thermal management system. Therefore, packaging and thermal management are two important supporting aspects of power electronics. The following section will discuss the present technology and the research needs for thermal management and packaging of power electronics. The reliability of power electronics is directly related to being able to keep the devices well within their safe operating level; and generally the cooler that a device can be kept, the less likely it is to fail.

### **6.1 Thermal Management**

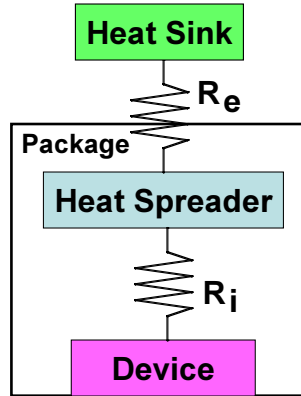
All of the electronics in a power converter for a utility application must operate under harsh conditions for long durations, with the most detrimental condition being high temperature. The major source of heat affecting power electronics is the heat generated by the power semiconductors themselves. These power devices have losses associated with conducting and switching high currents. Typically, a high-power converter would have efficiencies well above 95%. Assuming a 1-MW power converter with 99% efficiency, 10 kW of loss is dissipated as heat. With this much loss, a 1-MW power converter can be compared with a home oven running at full power. At higher power levels, the loss is much more. For example, a 100-MW power converter at 99% efficiency generates 1 MW of loss to be dissipated. These enormous amounts of losses imply that either more efficient and high-temperature power devices are needed, or effective thermal management systems are required, or some combination of both. Since the present power devices can only handle maximum junction temperatures of 150°C, an appropriate cooling system is needed to be able to dissipate the heat generated by power converters and keep the junction temperatures of power devices well below the limit.

Moreover, at high temperatures, the failure mechanisms in connections, interfaces, and devices are accelerated, decreasing device lifetime and reliability. Cooling is also used to minimize thermally induced mechanical stresses due to mismatches in the thermal expansion properties between the packaging material and the device. The thermal resistance due to packaging materials depends on their thermal conductivity, while the thermal stresses depend on the thermal expansion mismatch. There is always a trade-off between the thermal conductivity and stresses induced by thermal expansion of the packaging materials. Developing cooling methods for power electronic devices is a critical step toward overcoming high temperatures [1].

Three traditional options for cooling power devices are using natural air, forced air, or water-cooled heat sinks. The power rating of the converter determines the type of heat sink to use. For low-power converters, bulky natural-air-cooled heat sinks are sufficient, whereas high-power converters require more expensive but smaller liquid-cooled heat sinks. However, the latter requires a pump to circulate the coolant as well as a radiator and a fan to cool it. A heat sink typically occupies one-third of the total volume for a power converter and usually weighs more than the converter itself.

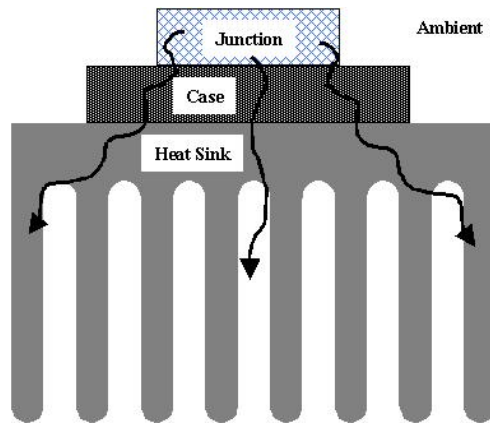
#### **6.1.1 Thermal Model**

Heat generated by power devices is dissipated through several components that include heat sinks, thermal gap fillers, heat pipes, heat spreaders, cold plates, radiators, and fans [2] in Fig. 6.1. These components are designed at the individual device and system level. Most of the thermal management solutions were envisioned based on simple heat transfer balance at component level and are now increasingly based on numerical simulations.

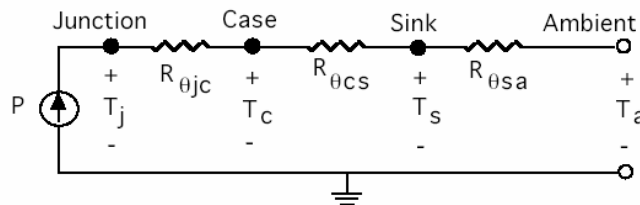


**Fig. 6.1. Schematic of thermal management systems.**

A simplified thermal management system is shown in Fig. 6.2 where a natural air-cooled heat sink with fins is shown. A typical steady state system-level simulation model for this system is shown in Fig. 6.3.



**Fig. 6.2. A simplified thermal management system with finned heat sink.**



**Fig. 6.3. System-level simulation model of the heat sink system in Fig. 6.2.**

The steady state junction temperature of a power device can simply be found from Eq. 6.1,

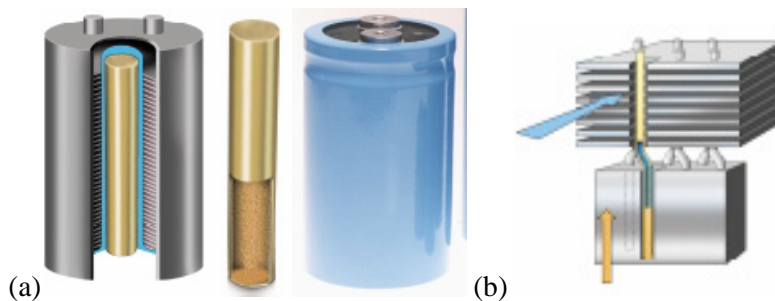
$$T_j = P \cdot (R_{\theta_{jc}} + R_{\theta_{cs}} + R_{\theta_{sa}}) + T_a, \quad (6.1)$$

where  $P$  is the generated loss,  $T_s$  are temperatures, and  $R_s$  are thermal resistances.

### 6.1.2 Present R&D Status

Most of the present effort in thermal management of power electronics is mainly focused on Si devices. Thermal management systems for wide bandgap semiconductor devices, such as those with SiC, are based on the same technologies as for Si devices. The application of Si solutions to SiC devices is possible since the current SiC devices are not developed to their full potential [3], and thermal management is more of a problem for Si devices than for SiC devices.

One of the novel thermal management systems uses heat pipes. A heat pipe cooler uses highly effective evaporation and condensation cycles to extend surface areas and improve heat transfer efficiency. In addition, heat pipes provide more packaging flexibility than extrusion heat sinks. Compared with other cooling techniques, such as forced single- and two-phase flow cooling and direct immersion cooling, heat pipe cooling does not require mechanical pumps or valves or consume any power; consequently, it is quieter and more reliable [4]. Heat pipe devices are now routinely used to transport the heat to an air-cooled fin section. Heat pipe applications fall into three categories: (1) heat pipe heat sinks, in which the heat pipe is placed in contact with the device and serves the same function as a heat sink; (2) mini/micro heat pipes and heat pipe spreaders, in which the device is an integral part of the heat pipe; and (3) heat pipe heat exchangers, which are system-level heat pipes used to control temperature in equipment cabinets or systems. In situations where there are several hundred watts to several kilowatts to be rejected, the electronics are mounted on large heat pipe units. The power devices are attached to a mounting plate; and the heat pipes, which are embedded in the plate, transport the heat to an air-cooled fin section. Figure 6.4 shows Thermacore, Inc.'s use of heat pipes in cooling power devices and capacitors. They use the technology to move heat to a location where enough air volume exists for adequate heat removal.



**Fig. 6.4. Thermacore heat pipe technology for (a) a capacitor, (b) Fins are stacked on the heat pipes to provide adequate surface area for heat dissipation to the air.**

Another newer development in thermal management is using a powdered-metal cold plate heat transfer matrix [5] as shown in Fig. 6.5. The highest heat flux was removed using this technique, as can be seen in Fig. 6.6.

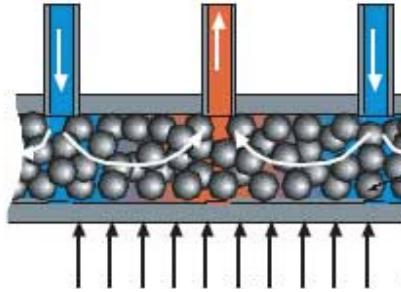


Fig. 6.5. The powdered metal cold plate heat transfer matrix.

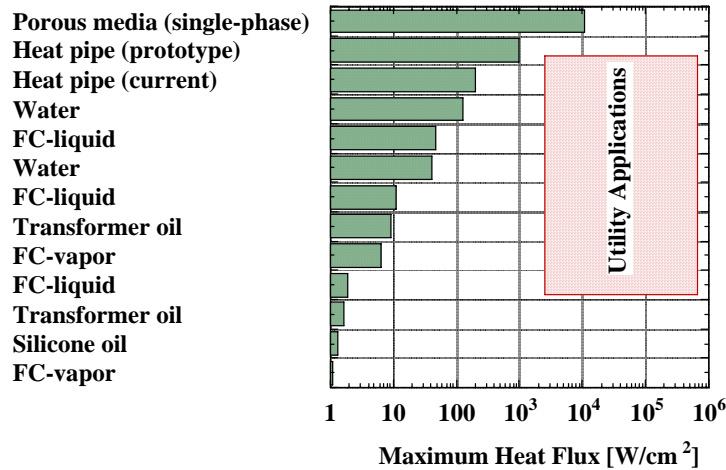


Fig. 6.6. Maximum heat flux removed (working fluids and technologies).

The heat removal capability in terms of device heat flux is shown in Fig. 6.6 for different technologies. The reported heat flux levels should be considered in relative terms, as the application conditions are not fixed. For example, for utility applications, a larger heat sink or an increase in air flow could be considered to remove more heat in the last packaging stage [6]. However, this would be at the expense of an overall increase in package volume and increased acoustic noise.

A comparison of the cooling technologies for Si devices is shown in Table 6.1, and some R&D programs are listed in Table 6.2.

### 6.1.3 Thermal Management Industry

Suppliers of thermal management systems include Aavid Thermalloy, Concord, NH; Thermacore, Lancaster, PA (heat sinks, heat pipes); Noren Products (heat pipes), Lytron (cold plate), and Fujipoly, Kenilworth, NJ; Thermagon, Cleveland, OH; and Chomerics (thermal gap fillers).

Most of the industry uses old technology. The availability of more reliable cooling systems for much higher power dissipation would require novel cooling technologies. How much the prototype technologies can be scaled up for utility applications has yet to be demonstrated.

**Table 6.1. Cooling technologies developed for Si devices**

Cooling technology	Applicability power electronics	Reliability	Comments
<b>Passive Cooling</b>			
Natural convection	-	+	Last component
Heat pipes	+	+	No moving parts, well developed, potential for novel technologies
<b>Active Cooling</b>			
Forced air and liquid convection (cold plate)	+	-	Moving parts, liquid leakage
Two-phase cooling	+	-	Moving parts, novel
Refrigerating and cryogenic cooling	-	-	No need since SiC devices operate at high temperature from ambient
Thermoelectric cooling	-	-	Requires electric power
Passive two-phase cooling	+	-	Totally passive systems demonstrated
MEMS cooling (microchannel, pump, heat pipe)	TBD	-	Novel, useful when space is limited

**Table 6.2. Present programs and active areas of R&D**

University	Funding agency	Program	Area
Purdue	NSF	Compact High Performance Cooling Technologies Research Center	Two-phase flow cooling
UCLA	DARPA	Heat removal by thermo-integrated circuits (HERETIC)	MEMS microjet array and biporous heat pipes
Carnegie Mellon	DARPA	HERETIC	Spray on-demand cooling
University of California, Berkeley	DARPA	HERETIC	Micro-capillary pumped loop cooler
Stanford	DARPA	HERETIC	Two-phase cooling systems using electrokinetic liquid pumps
Virginia Tech	NSF	Center for Power Electronics Systems	Thermal-mechanical integration
University of Arizona	NSF		Cooling technologies
ORNL	DOE	OTT	Carbon foam

#### 6.1.4 Technical Challenges—Areas of R&D Needs

1. **Development of new cooling technologies for utility applications.** These would include cooling technologies for dissipating power on the order of 1 MW. There are novel ideas for thermal management for low-power applications, and some of them might need some modification to be applied to utility-scale applications. These might include spot cooling

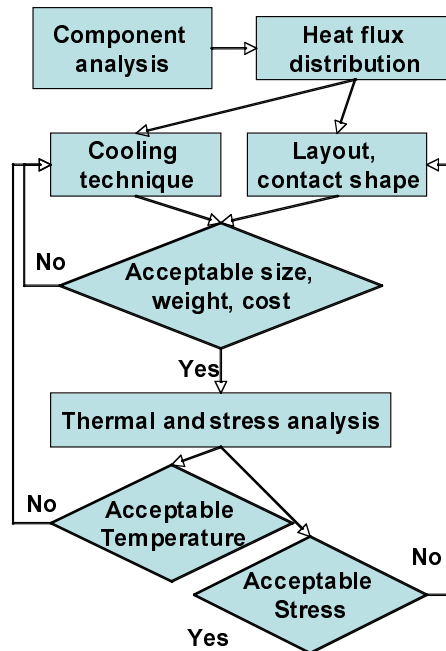


techniques, novel heat sinks, permeable media heat exchangers, and phase-change systems. Specific space requirements for utility applications will have to be considered.

2. **Coolant materials research.** Power electronics cooling techniques require some kind of fluid to transport the heat from the hot spots. For low-power applications, some of these fluids are readily available. Research on newer fluids that can transport much more heat is required for cooling utility-scale high-power applications.
3. **Cooling passive components.** In addition to the power devices, a utility-level power converter also contains passive components such as capacitors, inductors, and transformers. These are temperature-sensitive components, and they must be cooled as well. Some of the cooling techniques discussed earlier can be extended to cooling these passive components (Fig. 6.4).
4. **High-temperature components.** To reduce the size of the cooling system, more efficient power devices and passive components that can operate at higher temperatures are required. In the near future, SiC power devices are expected to replace Si power devices in utility applications. More information on these devices can be found in Chapter 5.

More research is required in developing high-temperature, more-efficient capacitors, inductors, and transformers. Some research is already going on in the low-power range, but this needs to extend to the high-power range. It would be beneficial to work with SiC power device, capacitor, inductor, and transformer manufacturers to contribute to the design of these components so that the final product would be optimized for utility applications.

5. **Including thermo-mechanical effects in packaging design.** The thermal conductivity of packaging materials decreases at high temperatures, and the mismatches in coefficient of thermal expansion (CTE) can lead to stress-related cracking of metallization or other thin films on the top surface of the device [7]. Reducing the thermal stresses has been identified as a technical challenge for power electronics [8]. Modern thermal management design has to consider stress management. An approach for the integration of heat transfer, thermo-mechanical, and thermoelectric effects is shown in Fig. 6.7.
6. **Including thermo-mechanical effects in converter controller design.** It has been shown in a recent technical article [9] that a converter controller can be modified to control the junction temperature of low-power devices. Similar methods and their interactions with the thermal system can be studied to determine if these methods are feasible for utility applications.
7. **Including thermoelectric effects** in the device analysis for accurate estimate of operating temperatures and ensuing heat fluxes. For more demanding applications, integration of thermal architecture with the electronics systems must be performed [10]. The overall amount of heat generated by the device has to be determined based on an analytical model of power losses [11, 12]. The models envisioned would take into account the dependency of the switching losses on various factors such as the switching voltage, switching current, and stray inductance.
8. **Nondestructive diagnostics or process monitoring equipment/sensors.** Examples could include the use of infrared, temperature, or heat flux sensors that can be used to assess the quality of thermal management and signal possible failures in cooling. The sensors could also be used to dynamically change the cooling requirements when additional thermal loads are imposed on the systems. These systems will ensure appropriate reliability for utility applications.



**Fig. 6.7. A modern thermal management design algorithm.**

9. **Development of new packaging materials.** High-temperature packaging materials need to be developed in order to take full advantage of the SiC devices. A metal matrix composite heat spreader with high thermal conductivity and low CTE might have the potential to solve many of the thermal management issues. Materials with CTEs similar to that of SiC would be preferred over those with high thermal conductivity but high CTE in order to reduce the thermal stresses. When the heat flux on the device is non-uniform, new thermal interface materials can be used [13]. Such materials could include a corrugated copper substrate with thermal grease that distributes the heat in the lateral direction more evenly, or graphite foam. The gel-like thermal interface material (TIM) eliminates the problem of leakage out of the interface. Low-melting-point alloys are designed so that they melt before reaching a maximum operating temperature, at which point they flow to fill the air gaps, significantly reducing the contact resistance.

## 6.2 Packaging of Power Electronics

Packaging technology for Si power devices is more or less a mature technology. The main concern is the reliability of packaging at high temperatures. This reliability is more of an issue for packaging SiC-based power devices that can run at much higher junction temperatures of (theoretically) up to 600°C, as compared with the 150°C operating temperature of Si power devices.

### 6.2.1 Requirements of a High-Temperature Package

Electronic packaging is a multidisciplinary technology that introduces additional complications in power electronics because of the advanced thermal management that is required for packaging of such devices. The functions of an electronic package can be classified into a few categories [14]:

1. Electrical interconnection-providing an electrical path for power and signals.
2. Thermal interconnections-providing a thermal path for the heat dissipated by the parts.
3. Electrical insulation-providing for the integrity of the electrical signals.
4. Environmental protection-providing protection of the parts and assembly from damage during handling and from the environment, especially moisture.
5. Mechanical support-providing mechanical support, rigidity, and ductility.

Typical packages used for devices consist of multiple elements. In designing a package for electronic devices to operate at up to 600°C in harsh environmental conditions, a few important factors have to be considered:

1. Mitigation of thermal stresses caused by thermal expansion mismatches between the devices and various package elements, including the substrate.
2. Thermal shock resistance needed to withstand thermal cycling during service.
3. Heat dissipation to keep the temperatures at safe operating levels.

### 6.2.2 Elements of a Typical High-Temperature Package

Figure 6.8 shows a cross-section of a typical state-of-the-art packaging technology used for packaging SiC devices. Functions of each of these elements are outlined below, along with the materials requirements.

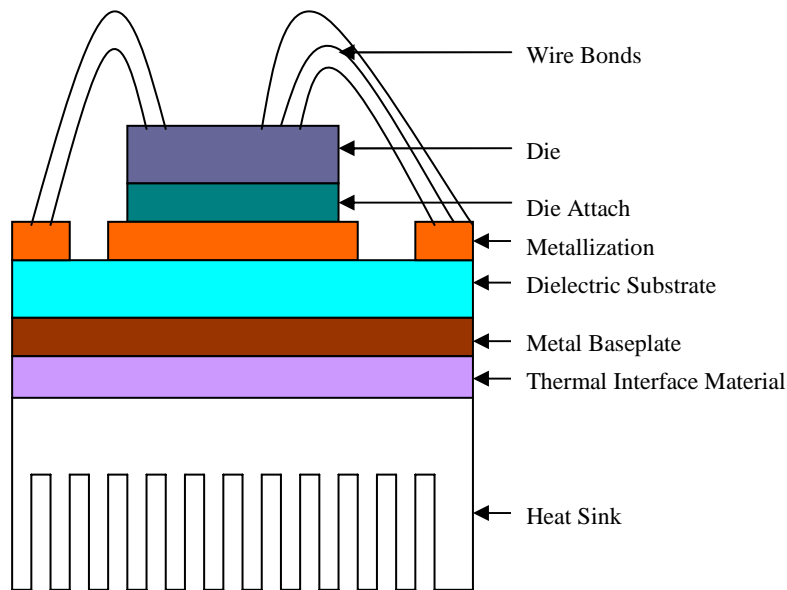
**Substrate.** The key part of the package is the insulating dielectric substrate, which has an electrically conductive metallization bonded to it on one surface. The insulating substrate can be either  $\text{Al}_2\text{O}_3$  or AlN, and the metallization layer either copper (as in direct-bonded copper) or gold. Since SiC devices are designed to operate at high temperatures and high voltages, it is critical that the substrates remain thermally and mechanically stable while retaining their dielectric properties to desired temperatures.

The metallization layer provides an electrical path between the multiple active and passive devices that may be bonded to the same substrate, and between the packaged devices and the external circuit. It is important that the metallization layer has good bonding with the substrate; it retains good electrical conductivity at high temperatures, and has a minimal tendency for the formation of intermetallic compounds. In addition, it is desirable that the metallization layer possesses good environmental resistance and resistance to electromigration. As a rule of thumb, the melting temperature must be at least 1.5 times the operating temperature, in degrees Kelvin, to prevent any diffusion-related problems such as creep and electromigration.

Although the substrate is electrically insulating, it is desirable that its thermal conductivity be high to enable efficient dissipation of heat away from the SiC die. Hence AlN, which has a higher thermal conductivity than  $\text{Al}_2\text{O}_3$ , is preferred from a thermal management perspective. Another important factor is the difference in the CTE between the device and the substrate. Larger differences in the CTEs cause larger thermal stresses. Both  $\text{Al}_2\text{O}_3$  and AlN have a CTE that compares well with that of SiC.

**Die-attaches.** The device or die is mechanically bonded to the metallization layer through the use of a die-attach. A die-attach material should have the following properties [15]:

1. Good adhesion with both the die and the substrate so that no debonding or delamination occurs.
2. Self-resilience to provide good stress relaxation behavior so that the internal stresses are reduced to low levels.
3. High thermal conductivity so that the heat dissipated from the power chip and the thermal expansion difference between the die and the substrate can be minimized.



**Fig. 6.8. Schematic of a typical state-of-the-art package used for packaging an SiC die for high-temperature use.**

4. An appropriate processing temperature and good thermal stability to fit the typical process hierarchy.
5. Good corrosion resistance.
6. Good reworkability.

Although organic materials have been used as die-attaches for packaging Si-based devices, these materials have limited applications in packages designed for temperatures greater than 250°C. High-temperature solders, such as Au-Sn, are used as die-attaches in SiC packaging. However, these solders typically melt at a temperature of less than 350°C and hence can be reliably used only at temperatures below 300°C. For higher-temperature packages, all materials should have melting points greater than the desired temperature of operation of 600°C.

**Wire-bonds.** The electrical path from the device to the package is achieved through the use of one or more wire-bonds. These are typically aluminum wire-bonds that are thermo-sonically bonded to the bond-pads on the device and to the metallization layer. Multiple wires are used for high-current applications and to reduce stray inductance. Wire-bonds are generally considered the weakest link within all the packaging elements.

In summary, a number of material properties impact the performance of a typical high-temperature package and need to be considered in the selection of materials. These include

1. **Thermal conductivity:** Dissipation of heat is critical, and all materials should have good thermal conductivity to minimize thermal resistance. In particular, effects of temperature on thermal conductivity must be considered.
2. **Thermo-mechanical compatibility:** Thermal expansion differences should be minimized to reduce stresses during assembly and during operation.

3. **Thermal shock resistance:** Elements should have high thermal shock resistance to prevent failures due to thermal shock from differential thermal stresses caused by thermal excursions and differential thermal expansions.
4. **Chemical compatibility:** The individual elements must be chemically compatible with minimal susceptibility to reactions, including formation of intermetallic compounds and other diffusional degradation of properties, such as creep and electromigration.
5. **Hermeticity:** The package should protect the device from environmental elements.
6. **Simplicity, size, and weight:** The package should be manufacturable and of an appropriate size and weight for the application.

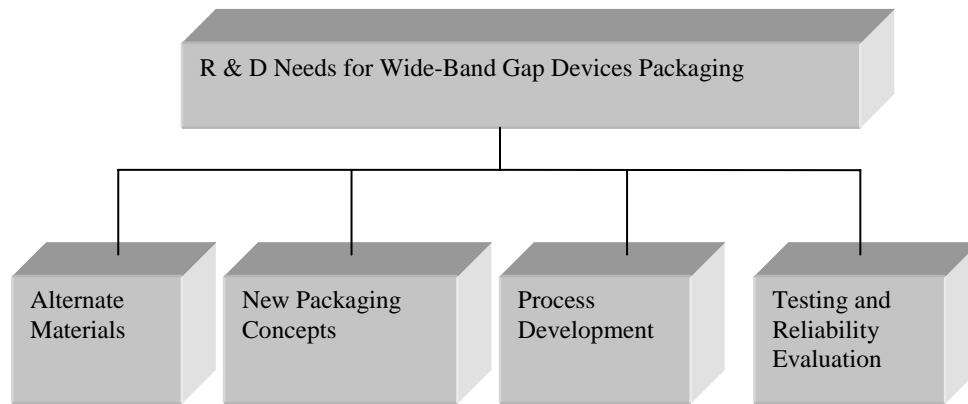
### 6.2.3 Ongoing Development Efforts

A number of organizations—including companies, national/government laboratories, and universities—are actively involved in efforts to develop materials and process solutions to enable packaging of wideband materials for high-temperature and high-voltage applications. Areas of research activities include assessment/development of new die-attach materials, metallizations, substrates, and wire-bonds. The following table shows typical organizations and their areas of R&D activity.

Organization	R&D areas	Temperature of operation
<b>Companies</b>		
Powerex	Metallizations, substrates, die-attaches, and wire-bonds	Up to 225°C
Semikron	Die-attaches, wire-bonds	Up to 350°C
SSDI	Metallizations, substrates, die-attaches, and wire-bonds	Up to 350°C
Northrup-Grumman	Metallizations, substrates, die-attaches, and wire-bonds	
<b>Research Laboratories</b>		
NASA Glenn Research	Metallization, die-attaches	Up to 500°C
Oak Ridge National Laboratory	Die-attaches, wire-bonds, gate drives	Up to 250°C
<b>Universities</b>		
Auburn University	Die-attaches, wire-bonds	
University of Arkansas	Metallizations, substrates, die-attaches, and wire-bonds	Up to 400°C
University of Maryland	Reliability of die-attaches, wire-bonds	
State University of New York–Buffalo	Metallizations, substrates, die-attaches, and wire-bonds	Up to 300°C

### 6.2.4 Future Research Needs

Based on the analysis of issues relevant to high-temperature packaging, combined with the assessment of on-going R&D activities, the following areas have been identified as critical to the further development of packaging technologies for wide bandgap devices for use at high temperatures and high voltages and in Fig. 6.9.



**Fig. 6.9. Summary of anticipated R&D needs for packaging of wide bandgap devices.**

### **1. Identification and/or development of alternate materials for use in existing packaging concepts**

One methodology that can be used to develop high-temperature packaging technologies is to identify new materials that are stable to higher temperatures but can replace materials in existing packaging technologies. An example is the replacement of organic die-attaches with high-temperature solders for attachment of a device to the substrate. Metallizations stable at temperatures of up to 600°C are needed, along with substrates that retain their dielectric properties to such temperatures. New die-attaches that can be processed at low temperatures (at or below 300°C) but are stable at temperatures up to 600°C are critically needed. Such die-attaches should have good chemical compatibility with the die and the substrate, along with desired CTEs to minimize thermal stresses. An example of the new generation of die-attaches is a nanosilver paste that can be processed at low temperatures but is stable at temperatures up to the melting point of silver. Further evaluation of such schemes is needed to make them worthwhile for routine use. Formation of tin whiskers in non-lead-containing die-attaches has to be investigated as part of an effort to develop non-leaded solders for die-attaches. Materials that possess desired electrical, mechanical, and environment-resistant properties are needed for wire-bonds that can be stable at temperatures of up to 600°C.

Detailed knowledge has to be developed as to how material properties and package reliability are affected when the metallic materials used in packages are exposed to high temperatures and potentially harsh/corrosive environmental conditions. In addition, material–material interactions have to be examined to understand the effect of such interactions on degradation of properties. The growth of intermetallics at dissimilar metal contacts is an example of such potentially deleterious interactions. Barrier layers to prevent the adverse growth of intermetallics must be developed. Since efficient heat removal is a key requirement in such packages, materials should have desirable thermal conductivity properties.

### **2. New concepts for high-temperature package designs**

Existing high-temperature packages have been designed primarily for applications with Si-based devices. While the basic requirements for packages for Si-based devices and wide bandgap devices are similar, there is a significantly larger emphasis on high-temperature stability, thermal management, and thermal stresses for wideband device packages. Furthermore, the mechanical

properties of SiC and Si are significantly different and could be used favorably in the design of packages. It is thus important to develop new conceptual designs for high-temperature packages that may be better suited for packaging wide bandgap devices. Packaging concepts that provide for efficient heat removal through the top and bottom surfaces of the devices have been suggested. Such concepts may be suitably adapted for high-temperature use through the selection of materials that are stable to desired high temperatures.

### **3. Design and development of alternative processes/process parameters for packaging and assembly**

With the advent of new materials, there is a need for modified processes for packaging and assembling packages for wide bandgap devices. Higher temperatures may be required for processing die-attaches and solders capable of being used at higher temperatures. Modified processes may also be required for wire-bonds of alternate materials. Thus a new set of processing tools may be required to process high-temperature packages consisting of alternate materials.

### **4. Methodologies for high-temperature electrical properties testing and reliability testing**

Standardized procedures are well established for testing the electrical characteristics and the reliability of Si-based devices, including accelerated tests to assess the reliability of devices, meant for lower-temperature use. Because the intended temperature ranges of use are significantly higher (up to 600°C) for packaging for wide bandgap devices, larger temperature fluctuations will be experienced in service. Thus reliability testing procedures need to be modified for assessing these devices. As new materials are introduced into the high-temperature packages, their effect on the reliability of packaged devices under steady state exposure to high temperatures and exposure to cyclic temperature fluctuations must be evaluated, in addition to other factors such as ease of processing. For example, new die-attaches such as nanosilver paste, should be selected based not only on their processing and operating temperatures but also on their ability to withstand cyclic temperature fluctuations.

## 7. RESEARCH NEEDS FOR POWER ELECTRONICS TO IMPACT THE GRID

This chapter provides a summary of recommendations for R&D in power electronics so that they can positively impact T&D and DE applications. Table 7.1 summarizes some of the needed research areas and indicates whether the government should make each area a high, medium, or low priority.

**Table 7.1. Recommendations for DOE to fund power electronics**

Technical area	Technical issue	Comments	Government role
Applications: T&D	Power electronics test facility	Provide a full spectrum of events that a device or system might see over the course of its life	High
	Advanced topologies	Enable lower-cost design with built-in redundancies	Moderate
	Balance-of-plant reliability improvements	Power electronics cannot tolerate a failure in any of their support systems	Low
	Next-generation FACTS devices	Combine optimal characteristics of components to develop novel devices	Low
	Cost reductions	Advanced materials are needed to increase voltage and current ratings to reduce the number of devices	High
	Reduced real estate for urban areas, reduced security risks	Emphasis on thermal management systems, higher voltage and current ratings on semiconductor devices	High
Applications: DE	Advanced controls for multiple systems dispatch	New control algorithms have to be developed.	Moderate
	Reduced system costs	Magnetic parts and cable looms	Low
	Ancillary services from DE	Determine where ancillary services are appropriate; develop algorithms and control schemes; and identify markets	Moderate/ High
Semiconductor devices	Higher reliability	Thermal, voltage, and current-related controls are needed that increase reliability but do not increase costs.	Medium
	Expanded device ratings	Higher voltage, current, and frequency ratings for devices such as MOSFETs, IGBTs, and IGCTs.	High
	Reduced cost	PEs have the largest impact on converter costs; thus reducing their costs will lower project costs.	Medium
Wide bandgap materials	System-level impact	Studies evaluating the impact of wide bandgap semiconductors on electric grid are required.	High
	Materials processing	CVD and/or RAF processing must yield defect-free, 4-in. wafers for high-current SiC devices.	High
	High-voltage SiC devices	SiC MOSFETs and IGBTs are essential devices for utility applications.	High
	Partnerships	Partnering with other U.S. government agencies to maximize technology progress.	High
	SiC IGBTs	SiC IGBTs could replace Si GTOs in medium-voltage applications.	High
	Packaging of SiC devices	SiC devices use Si device packaging. High-temperature packages are required to take advantage of the capabilities of SiC devices	High



## 7.1 Transmission and Distribution Applications

For widespread R&D of power semiconductor devices by utilities, further advances must be achieved. Several areas need to be addressed.

- **Semiconductor device cost reduction.**

The cost of FACTS devices has been a major hurdle for commercialization in the United States. For example, the cost of a static var compensator is twice that of a capacitor bank with the same rating, and the cost of STATCOM is three times that of traditional technologies. Utilities are waiting for reduction of the costs of FACTS devices. A standard design rather than a custom design is a good way to reduce the cost. Developing high-power and faster-switching devices can lead to reducing the number of components, thereby reducing overall system costs.

Another approach to reducing costs is to combine optimal characteristics of components. Future developments will include the combination of existing devices, e.g. combining a STATCOM with a thyristor-switched capacitor to extend the operational range and combine the best features of each. In addition, more sophisticated control systems will improve the operation of FACTS devices.

Research should also be conducted on a FACTS building block. One of the reasons FACTS installations are expensive is that each one requires custom engineering, design, and installation. The costs for these installations would be less if standard design and equipment could be used. If a FACTS installation could be composed of “standard” and reliable FACTS building blocks, that practice might lead to more widespread acceptance by utilities and lower total installed cost.

- **Improve the reliability of active and passive components, including balance-of-plant components.**

The grid must be extremely reliable; however, power electronic devices are not as reliable as is required for grid applications. They can be improved to have much higher reliability.

- **Develop advanced control systems for multiple converters.**

There might be multiple power converters connected to the T&D system. These converters might induce circulating current in one another, and/or their functions might compete with one another. Presently, limited research has been done on controlling multiple power converters. Better, more advanced control systems must be developed to better utilize multiple converter systems tied to the grid.

- **Reduce harmonics and electromagnetic interference.**

Development of switching strategies that minimize harmonics or different converter topologies, such as multilevel converters that minimize the generation of harmonics, is needed. In addition, the ability to switch at higher switching frequencies would enable harmonics to be more easily filtered out with smaller capacitor and/or inductors.

- **Develop a test-bed for power electronics components and systems.**

The demonstration phase of advanced technologies is typically a cautious attempt by the utility industry to operate in a field environment, but it can be quite expensive and of little value if the technology is not fully evaluated because it is operated in a low-impact location or not placed into full service. Since many demonstrations do not provide a full spectrum of events that a device or system might see over the course of its life, the credibility of the technology may require many expensive demonstrations and years of field testing to gain the confidence of the utility industry. Thus the expensive and lengthy technology demonstrations must be resolved by providing a full-power (high-voltage and high-current) testing environment that can fully test and evaluate a range of early prototypes to near-commercial transmission technologies. This process would both reduce the lead time to implementation

and reduce the cost and duration of demonstration projects that would follow. In addition, utilities would be more willing to implement a new technology that has been proved in an extreme test environment.

- **Improvements in HVDC research and development.**

HVDC is known for its high-power capability, excellent stability performance, flexible control, and regulation. However, at present, disadvantages such as low reliability in the initial phase of operation; complicated control; high requirements for operators; and the risk of inducing sub-synchronous resonance of large turbo-generators, harmonics pollution, etc., are problems to be solved. Particular issues that need further research and simulation testing include the following.

- Improvements in semiconductor switches will directly transfer to HVDC applications and are essential for further advancement of this technology.
- When several HVDC circuits send power to receiving terminals close to one another, a fault on the ac system could create a simultaneous outage of the dc system. Research is needed to ensure the reliability of the bulk power system.
- Research is needed to exploit the modulation capability of the dc systems to strengthen the ac/dc hybrid system.
- Enhanced equipment reliability and improved designs for the converter station and the HVDC lines are needed.
- For the network interconnection with other networks, a back-to-back HVDC scheme may have advantages from the system operation and economic points of view. Research should be undertaken on this aspect.
- It should be determined whether different circuit topologies such as the multilevel converter allow a more inexpensive or more reliable interface to be developed for HVDC converter stations.

- **Distributed energy systems.**

- Develop new materials and packaging to decrease the cost of power electronics for DER systems.
- Develop software tools that can analyze the dynamic capabilities of power electronics-based DER systems.
- Standardize controls and communications interfaces for power electronics for DER systems.
- Develop new distribution circuit designs that offer none of the limitations of current radial systems and that take greater advantage of power electronics-based DER systems.
- Develop advanced control algorithms for power electronics systems to take full advantage of the compensation capabilities of converter systems, such as reactive power injection. Evaluate the capability of DER to provide ancillary services and evaluate the likelihood of a market for those services.
- Test single and multiple power electronics-based DER systems on distribution networks to identify the performance characteristics and limitations of existing technology.
- Identify guidelines or “rules of thumb” for the interconnection and operation of single and multiple DER systems with power electronics.
- Develop analysis tools that can help to optimize the placement of DER in a system so that it has the greatest positive impact on the distribution system.

## 7.2 Wide Bandgap Semiconductors

SiC is the most mature technology among the wide bandgap semiconductors and is the best one for near-term utility power electronics applications. Presently, most wide bandgap semiconductor research is focused on improving the quality of the SiC material so that high-current power devices could be possible. In addition to materials research, new SiC power devices are being developed. SiC wafer manufacturing companies, DARPA, the Army Research Lab, and the Air Force are spending significant sums of money to do SiC materials research. It is recommended that DOE develop partnerships with these R&D organizations. For utility power electronics, the following research items for SiC power devices need more attention:

- System-level impact. SiC devices have superior performance compared with their Si counterparts at the device level. Presently, extensive studies on the system-level impact of these devices at the utility level are not available to quantify the superiority of SiC-based systems. Only after some of these studies are completed will there be a clear picture of how important these devices are to the grid.
- High-voltage SiC devices. Most of the SiC device research focuses on devices with blocking voltages of 10 kV and lower with low current ratings. SiC devices can block much higher voltages than Si power devices can, and utility applications need high-voltage blocking and high current-carrying capabilities. For this reason, more research is required on high-voltage-blocking (50 kV and higher) SiC power devices with high current ratings (>100 A). SiC companies must be motivated to design and build more utility-compatible power devices.
- SiC IGBTs. As explained in Chapter 4, IGBTs are the most preferred power devices, but the blocking voltage ratings of Si IGBTs are limited to 6.5 kV and lower. Theoretically, SiC IGBTs can be built to block much higher voltages, and they can replace GTOs in medium-voltage applications. One major problem associated with building SiC IGBTs is the SiO<sub>2</sub> interface. This interface still presents structural problems as well as high-temperature operation problems. More research is required to improve this interface before reliable SiC IGBTs can be built that can be operated at high temperatures.
- Packaging of SiC devices. SiC devices can run at junction temperatures much higher than those of Si power devices; however, they still use conventional Si device packages, which limits their operating temperature. New power device packages need to be developed that can handle SiC devices running at 250°C or above so that the capabilities of SiC power devices can be optimally utilized.

## 7.3 Thermal Management

- **Development of new cooling technologies for utility applications.** These would include cooling technologies for dissipating total power on the order of 1 MW. There are novel ideas for thermal management for low-power applications, and some of them might need some modification to be applied to utility-scale applications. These might include spot cooling techniques, novel heat sinks, permeable media heat exchangers, and phase-change systems. Specific space requirements for utility applications will have to be considered.
- **Coolant materials research.** Power electronics cooling techniques require some kind of fluid to transfer the heat from the hot spots. For low-power applications, some of these fluids are readily available. Research on newer fluids that can transfer much more heat is required for cooling utility-scale high-power applications.
- **Cooling passive components.** In addition to the power devices, a utility-level power converter contains passive components such as capacitors, inductors, and transformers. These are temperature-sensitive components, and they must be cooled as well. Some of the cooling

techniques discussed earlier can be extended to cooling these passive components (shown previously in Fig. 6.4).

- **High-temperature components.** To reduce the size of the cooling system, more efficient power devices and passive components that can operate at higher temperatures are required. In the near future, SiC power devices are expected to replace Si power devices in utility applications. (More information on these devices can be found in Chapter 5.) Since they are more efficient than Si power devices, less heat will be dissipated when SiC devices are used in power converters. Because of this, and because of their high-temperature (>300°C) operation capability, less thermal management is required.
  - More research is required to develop high-temperature, more efficient capacitors, inductors, and transformers. Some research is already going on in the low-power range, but it needs to be extended to the high-power range.
  - It would be beneficial to work with SiC power device, capacitor, inductor, and transformer manufacturers to contribute to the design of these components so that the final product would be optimized for utility applications.
- **Thermo-mechanical effects in packaging design.** The thermal conductivity of packaging materials decreases at high temperatures, and the mismatches in CTE can lead to stress-related cracking of metallization or other thin films on the top surface of the device [1]. Reducing the thermal stresses has been identified as a technical challenge for power electronics [2]. Modern thermal management design must consider stress management. (An approach for the integration of heat transfer, thermo-mechanical, and thermoelectric effects is shown in Fig. 4.8 in Chapter 4.)
- **Thermo-mechanical effects in converter controller design.** It has been shown in a recent technical article [3] that a converter controller can be modified to control the junction temperature of low-power devices. Similar methods and their interactions with the thermal system can be studied to determine if these methods are feasible for utility applications.
- **Thermoelectric effects in the device analysis** for accurate estimation of operating temperatures and ensuing heat fluxes. For more demanding applications, the integration of thermal architecture with the electronics systems must be performed [4]. The overall amount of heat generated by a device must be determined based on an analytical model of power losses [5, 6]. The models envisioned would take into account the dependency of the switching and conduction losses on various factors such as the switching voltage, switching current, and stray inductance.
- **Nondestructive diagnostics or process monitoring equipment/sensors.** Examples could include the use of infrared, temperature, or heat flux sensors that can be used to assess the quality of thermal management and signal possible failures in cooling. The sensors could also be used to dynamically change the cooling requirements when additional thermal loads are imposed on the systems. These systems will ensure an appropriate reliability for utility applications.

## 7.4 Packaging

- **Development of new packaging materials.** High-temperature packaging materials need to be developed to take full advantage of SiC devices. A metal matrix composite heat spreader with high thermal conductivity and low CTE might have the potential to solve many of the thermal management issues. Materials with CTEs similar to that of SiC would be preferred over those with high thermal conductivity but high CTE, in order to reduce the thermal stresses. When the heat flux on the device is non-uniform, new thermal interface materials can be used [7]. Such materials could include a corrugated copper substrate with thermal

grease that distributes the heat in the lateral direction more evenly, or graphite foam. The gel-like thermal interface material eliminates the problem of leakage out of the interface. Low-melting-point alloys are designed so that they melt before reaching a maximum operating temperature, at which point they flow to fill the air gaps, significantly reducing the contact resistance.

- **Identification and/or development of alternate materials for use in existing packaging concepts.** One methodology that can be used to develop high-temperature packaging technologies is to identify new materials that are stable at higher temperatures but that can replace materials in existing packaging technologies. An example for this approach is the replacement of organic die-attaches with high-temperature solders for attachment of devices to substrates. Metallizations stable at temperatures of up to 600°C are needed, along with substrates that retain their dielectric properties at such temperatures. New die-attaches that can be processed at low temperatures (at or below 300°C) but that are stable to temperatures of up to 600°C are critically needed. Such die-attaches should have good chemical compatibility with the die and the substrate, along with desired CTEs to minimize thermal stresses. An example of the new generation of die-attaches is a nanosilver paste that can be processed at low temperatures but is stable at temperatures up to the melting point of silver. Further evaluation of such schemes is needed to make them worthwhile for routine use. Formation of tin whiskers in non-lead-containing die-attaches must be investigated in the effort to develop non-leaded solders for die-attaches. Materials that possess desired electrical, mechanical, and environment-resistant properties are needed for wire bonds that can be stable at temperatures of up to 600°C.
- **Knowledge of how harsh conditions affect materials.** Detailed knowledge must be developed as to how material properties and package reliability are affected when the metallic materials used in packages are exposed to high temperatures and potentially harsh/corrosive environmental conditions. In addition, material-material interactions must be examined to understand the effect of such interactions on degradation of properties. Growth of intermetallics at dissimilar metal contacts is an example of such potentially deleterious interactions. Barrier layers to prevent adverse growth of intermetallics must be developed. Since efficient heat removal is a key requirement in such packages, materials should have desirable thermal conductivity properties.
- **New concepts for high-temperature package designs.** Existing high-temperature packages have been designed primarily for applications with Si-based devices. While the basic requirements for packages for Si-based devices and wide bandgap devices are similar, there is a significantly larger emphasis on high-temperature stability, thermal management, and thermal stresses with wide bandgap device packages. Furthermore, the mechanical properties of SiC and Si are significantly different and could be used favorably in the design of packages. It is thus important to develop new conceptual designs for high-temperature packages that may be better suited for packaging wide bandgap devices. Packaging concepts that provide for efficient heat removal through the top and bottom surfaces of the devices have been suggested. Such concepts may be suitably adapted for high-temperature use through selection of materials that are stable to desired high temperatures.
- **Design and development of alternative processes/process parameters for packaging and assembly.** With the advent of new materials, there is a need for modified processes for packaging and assembly of packages for wide bandgap devices. Higher temperatures may be required for processing die attaches and solders capable of being used at higher temperatures. Modified processes may also be required for wire bonds of alternate materials. Thus a new set of processing tools may be required to process high-temperature packages consisting of alternate materials.

- **Methodologies for high-temperature electrical properties testing, and reliability testing.** Standardized procedures are well established for testing the electrical characteristics and the reliability of Si-based devices meant for lower-temperature use, including accelerated tests to assess the reliability of devices. Since the intended temperature ranges of use are significantly higher (up to 600°C) for packages for wide bandgap devices, larger temperature fluctuations will be experienced in service. Thus reliability testing procedures need to be modified for assessing these devices. As new materials are being introduced into the high-temperature packages, their effects on the reliability of packaged devices under steady state exposure to high temperatures and exposure to cyclic temperature fluctuations must be evaluated, in addition to other factors such as ease of processing. For example, new die-attaches (such as nanosilver paste) should be selected not only for their processing and operating temperatures but also for their ability to withstand cyclic temperature fluctuations.

## 8. REFERENCES

### Chapter 2

1. The Wall Street Journal, "Transmission Flaws Boost Power Costs," December 20, 2001. Original source: FERC.
2. J. J. Paserba, "How FACTS Benefits ac Power Systems," Panel Session on FACTS Fundamentals, *Proceedings of the IEEE PES 2004 General Meeting*, Denver, CO, June 2004.
3. P.M. Marston, *Of Chips, HiTS, Bits and Bytes: Building the Powerline Paradigm*, A Report and Recommendations of the Grid Enhancement Forum, The Center for the Advancement of Energy Markets, 2002.
4. R.J. Koessler, "FACTS Seminar Technical Justification," ABB Consulting, Albany, NY, May 14, 2003.
5. D.J. Gotham, and G.T. Heydt, "Power Flow Control and Power Flow Studies for Systems with FACTS Devices," *IEEE Transactions on Power Systems*, Vol. 13, Issue 1, Feb. 1998, pp. 60–65.
6. T. Adhikari, "Application of Power Electronics in the Transmission of Electrical Energy," TENCON '98, 1998 IEEE Region 10 International Conference on Global Connectivity in Energy, Computer, Communication and Control, Vol. 2, Dec. 17–19, 1998, pp. 522–530.
7. K. Habur, and D. O'Leary, "FACTS: For Cost Effective and Reliable Transmission of Electrical Energy," Siemens.
8. W. Breuer, D. Povh, D. Retzmann, E. Teltsch, and X. Lei., "Role of HVDC and FACTS in Future Power Systems," CIGER Symposium, Shang Hai, 2004.
9. "DC Systems - HVDC and HVDC Light," [www.abb.com/hvdc](http://www.abb.com/hvdc).
10. Y. Song and A.T. Johns, *Flexible AC Transmission Systems*, IEE Power and Energy Series 30, 1999.
11. I. Etxeberria-Otadui, S. Bacha, A. Bachry, Z. Styczynski, M. Fracchia, and M. Stuart, "Power Electronic Converters for Railway Infrastructure Upgrading: Advantages and Potential Risks," *Power Systems and Communication Infrastructures for the Future*, Beijing, September 2002.
12. M.A.S. Masoum, S.M. Mousavi Badejani, and A. Kazemi, "Analysis and Control of Voltage Harmonics Generated by Thyristor-Controlled Series Capacitors," *Proceeding of Power and Energy Systems*, PES 2004, Nov. 28, 2004–Dec. 1, 2004, Clearwater Beach, FL, 2004.
13. X. Zhou, "Power System Development and Nationwide Grid Interconnection in China," Electric Power Research Institute, China.
14. Leon M. Tolbert, Fang Z. Peng, "Multilevel Converters as a Utility Interface for Renewable Energy Systems," *IEEE Power Engineering Society Summer Meeting*, July 15-20, 2000, Seattle, Washington, pp. 1271-1274.
15. J. S. Lai, F. Z. Peng, "Multilevel Converters - A New Breed of Power Converters," *IEEE Transactions on Industry Applications*, vol. 32, no.3, May/June 1996, pp. 506-517.

### Chapter 3

1. R.H. Staunton, B. Ozpineci, "Microturbine Power Conversion Technology Review," ORNL/TM-2003/74, Oak Ridge National Laboratory, Oak Ridge, TN, April 2003.
2. G.K. Andersen, C. Klumpner, S.B. Kjaer, F. Blaabjerg, "A New Green Power Inverter for Fuel Cells," IEEE 33<sup>rd</sup> Annual Conference of Power Electronics Specialists Conference (PESC), Vol. 2, 2002, pp. 727–733.
3. R.H. Lasseter, "MicroGrids," IEEE Power Engineering Society Winter Meeting, Vol.1, Jan. 2002, pp.305–308.
4. J. Lyons, Bowman Power, 23 September 2005, personal correspondence.
5. E. Hirst and B. Kirby, *Creating Competitive Markets for Ancillary Services*, ORNL/CON-448, Oak Ridge National Laboratory, Oak Ridge, TN, October 1997.
6. *Standard for Interconnecting Distributed Resources with Electric Power Systems*, IEEE Standard 1547, IEEE, Piscataway, NJ, 2003.
7. R. Tirumala, N. Mohan, and C. Henze, "Seamless Transfer of Grid-Connected PWM Inverters between Utility-Interactive and Stand-Alone Modes," IEEE 17<sup>th</sup> Annual Conference of Applied Power Electronics Conference and Exposition (APEC), Vol. 2, March 2002, pp. 1081–1086.

### Chapter 4

1. [http://www.darpa.mil/DARPATech2000/Presentations/mto\\_pdf/7MartinezGaNandRelatedWBGB&W.pdf](http://www.darpa.mil/DARPATech2000/Presentations/mto_pdf/7MartinezGaNandRelatedWBGB&W.pdf).
2. [[http://www.cpes.vt.edu/cpespubs/proceedings/files/1999pdf/I\\_1.PDF](http://www.cpes.vt.edu/cpespubs/proceedings/files/1999pdf/I_1.PDF)].
3. G. Majumdar, "Future of Power Semiconductors," 35th Annual IEEE Power Electronics Specialists Conference, Vol. 1, June 20–25, 2004, pp. 10–15.
4. [http://www.semicon.toshiba.co.jp/eng/prd/pdf\\_presen/tr\\_IEGT\\_200502\\_e.pdf](http://www.semicon.toshiba.co.jp/eng/prd/pdf_presen/tr_IEGT_200502_e.pdf).
5. E.I. Carroll, "Power Electronics for Very High Power Applications," *Power Engineering Journal* 13, Issue 2, April 1999, pp. 81–87.
6. [http://www.ee.ryerson.ca/~ieee/GRW/Pages1\\_15\\_RWP\\_Proceedings\\_2005.pdf](http://www.ee.ryerson.ca/~ieee/GRW/Pages1_15_RWP_Proceedings_2005.pdf).
7. R. Chokhawala, B. Danielsson, L. Angquist, "Power Semiconductors in Transmission and Distribution Applications," ISPSD '01. *Proceedings of the 13th International Symposium on Power Semiconductor Devices*, June 4–7, 2001, pp. 3–10.
8. H. Dettmer, U. Krumbein, H. Lendenmann, S. Muller, W. Fichtner, F. Bauer, K. Lilja, and T. Stockmeier, "A Comparison of the Switching Behavior of IGBT and MCT Power Devices," ISPSD '93, *Proceedings of the 5th International Symposium*, May 18–20, 1993, pp. 54–59.
9. Y. Li, A.Q. Huang, F.C. Lee, "Introducing the Emitter Turn-off Thyristor (ETO)," Thirty-Third IAS Annual Meeting, *Proceedings of the 1998 IEEE*, Vol. 2, Oct. 12–15, 1998, pp. 860–864.
10. Z. Xu, Y. Bai, B. Zhang, A.Q. Huang, "The Uniform Turn-on of the Emitter Turn-off Thyristor," APEC 2002, *Proceedings of the Seventeenth Annual IEEE*, Vol. 1, March 10–14, 2002, pp. 167–172.



11. L. Lorenz, G. Deboy, A. Knapp, and M. Marz, "COOLMOSTM: A New Milestone in High-Voltage Power MOS," *ISPSD '99, Proceedings of the 11th International Symposium*, May 26–28, 1999, pp. 3–10.
12. H. Akagi, "Prospects of New Technologies for Power Electronics in the 21st Century," *Transmission and Distribution Conference and Exhibition 2002: Asia Pacific, Proceedings of the IEEE/PES*, Vol. 2, Oct. 6–10, 2002, pp. 1399–1404.
13. F.C. Lee, "The State-of-the-Art Power Electronics Technologies and Future Trends," *Power Engineering Society Summer Meeting, 2000. IEEE Proceedings*, Vol. 2, July 16–20, 2000, pp. 1229–1232.

## Chapter 5

1. <http://www.darpa.mil/mto/hpss/1998MgWts.html>
2. L.M. Tolbert, B. Ozpineci, S. K. Islam, M. Chinthavali, "Wide Bandgap Semiconductors for Utility Applications," *IASTED International Conference on Power and Energy Systems (PES 2003)*, February 24–26, 2003, Palm Springs, CA, pp. 317–321.
3. P.G. Neudeck, L.G. Matus, "An Overview of Silicon Carbide Device Technology," *Ninth Symposium on Space Nuclear Power Systems*, Albuquerque, NM, Jan. 12–16, 1992.
4. NEDO, "Development of Ultra Low Loss Power Devices Technology."
5. P. Roussel, "Silicon Carbide Material, Devices and Application: Evaluating the Current Market and Future Trends," *Compound Semiconductor*, September 2003.
6. <http://icscrum2003.inpg.fr/sessions%20oraux7juillet/industrialnews.pdf>
7. C. M. Johnson, N. G. Wright, M. J. Uren, K. P. Hilton, M. Rahimo, D. A. Hinchley, A. P. Knights, D. J. Morrison, A. B. Horsfall, S. Ortolland, A. G. O'Neil, "Recent Progress and Current Issues in SiC Semiconductor Devices for Power Applications," *IEE Proc-Circuits, Devices, and Systems*, Vol. 148, No. 2, April 2001, pp 101-108.
8. D. Nakamura, I. Gunjishima, S. Yamaguchi, T. Ito, A. Okamoto, H. Kondo, S. Onda, K. Takator, "Ultrahigh-Quality Silicon Carbide Single Crystals," *Nature*, vol. 430, August 26, 2004, pp. 1009-1012.
9. H. Matsunami, "Progress in Wide Bandgap Semiconductor SiC for Power Devices," *Proceedings of the 12th International Symposium on Power Semiconductor Devices and ICs*, May 22–25, 2000, pp. 3–9.
10. J. L. Hudgins, "Gallium Nitride – The Other Wide Bandgap Semiconductor," *IEEE Power Electronics Society Newsletter*, Second Quarter 2005, pp. 13–15.
11. R. Borges, "Rf Semiconductor Gallium Nitride Electronic Devices for High-Power Wireless Applications.
12. S. Karmalkar et al., *IEEE Electronics Device Lett.* 22, 373–375 (2001).
13. M.A. Khan et al., *Appl Phy Lett* 65, 1121–11231 (1994).
14. S. Karmalkar and U.K. Mishra, *Solid State Electron* 45, 1645–1652 (2001).
15. [http://www.darpa.mil/DARPATech2000/Presentations/mto\\_pdf/7MartinezGaNandRelatedWBGB&W.pdf](http://www.darpa.mil/DARPATech2000/Presentations/mto_pdf/7MartinezGaNandRelatedWBGB&W.pdf)
16. <http://www.darpa.mil/DARPATech2000/>

17. B. Ozpineci, L. M. Tolbert, "Comparison of Wide-Bandgap Semiconductors for Power Electronics Applications" Oak Ridge National Laboratory.
18. S. N. Mohammad, A. Salvador, and H. Morkoç, "Emerging GaN-Based Devices," *Proc. IEEE* 83, 1306–1355, 1995.
19. H. Morkoç, S. Strite, G. B. Gao, M.E. Lin, B. Sverdlov, and M. Burns, "A Review of Large Bandgap SiC, III-V Nitrides, and ZnSe Based II-VI Semiconductor Structures and Devices" *J. Appl. Phys. Reviews* 76 (3), 1363–1398 (1994).
20. Usui et al., *Jap. J. Appl. Phys. Part 2*, 36, L899–L901 (1997).
21. Q. Chen, *Materials Science and Engineering B* 59, 395–400 (1999).
22. S. Fischer et al., *Symposium Proceedings*, EGN–1, 1996.
23. P. Kung et al., *Appl. Phys. Lett.* 69, 2116–2118, (1996)
24. F. Semond et al., *Appl. Phys. Lett.* 78, 335–337, (2001)
25. S. J. Pearton, J. C. Zolper, R. J. Shul, and F. Ren, "GaN: Processing, Defects, and Devices," *J. Appl. Phys.* 86.
26. G. T. Dang, A. P. Zhang, et al., "High-Voltage GaN Schottky Rectifiers," *IEEE Transactions on Electron Devices* 47, No.4, April 2000, pp. 692–696.
27. M. Trivedi, K. Shenai, "Performance Evaluation of High-Power Wide Bandgap Semiconductor Rectifiers," *American Physics Institute Journal of Applied Physics* 85, No. 9, May 1999, pp. 6889–6897.
28. J. L. Hudgins, G. S. Simm, and M. A. Khan. "A New Assessment of the Use of Wide Bandgap Semiconductors and the Potential of GaN," *The 33d Annual IEEE Power Electronics Specialists Conference (PESC02)*, Cairns, Australia, 2002, pp. 1747–1752.
29. Y. Gurbuz, W.P. Kang, J. L. Davidson, D.V. Kerns, and Q. Zhou, "PECVD Diamond-Based High-Performance Power Diodes," *IEEE Transactions on Power Electronics* 20, No. 1, Jan. 2005.
30. R. C. Burns, G. J. Davies, "The Properties of Natural and Synthetic Diamond," Academic Press, London, 1993, pp. 396–422.
31. J. E. Butler, D. G. Goodwin "Properties, Growth, and Applications of Diamond," *INSPEC 2001, IEE*, London, pp. 262–263.
32. K. Nassau, "Gems Made by Man Chilton," Radnor, 1980.
33. D. D. Clark, A. T. Collins, G. S. Woods, "The Properties of Natural and Synthetic Diamond," Academic Press, London, United Kingdom, 1993.
34. W. Zhu, "Diamond: Electronic Properties and Applications," Kluwer Academic Press, 1995, pp. 175–239.

## Chapter 6

1. D.A. Marckx, et al., *Breakthrough in Power Electronics from SiC*, NREL Report, 2005.
2. S. Davis, "Cooling Trends Direct Efficient Thermal Design," ([http://powerelectronics.com/mag/power\\_cooling\\_trends\\_direct/](http://powerelectronics.com/mag/power_cooling_trends_direct/)), 2002.

3. A.K. Agarwal, S, Seshadri, M. MacMillam, S.S. Mani, J. Casady, P. Sanger, and P. Shah, "4H-SiC p-n Diodes and Gate Turnoff Thyristors for High-Power, High-Temperature Applications, *Solid-State Electronics* 44 (2), pp. 303–308 (2000).
4. M.C. Zaghdoudi, C. Tantolinand, and C. Godet, "Use Of Heat Pipe Cooling Systems in the Electronics Industry," *Electronics Cooling* 10 (<http://www.electronics-cooling.com/html/articles.html>), 2004.
5. M.T. North, and W.-L. Cho, "High Heat Flux Liquid-Cooled Porous Metal Heat Sink," *Proceedings of Interpack '03*, ASME paper IPACK2003-35320, Kaanapali, HI, July 2003.
6. M.J. Ellsworth, Jr., and R.E., Simons, "High-Powered Chip-Cooling Air and Beyond, Electronics Cooling," Vol. 11 (<http://www.electronics-cooling.com/html/articles.html>), 2005.
7. A.C. Cotler, E.R. Brown, V. Dhir, and M.C Shaw, "Chip-Level Spray Cooling of an LD-MOSFET RF Power Amplifier," *IEEE Transactions on Components and Packaging Technologies* 27 (2), pp. 411–416 (2004).
8. S. Atcitty and W.I. Bower, *Power Electronics: Workshop on System Driven Approach for Inverter R&D*, April 23–24, 2003, Sandia National Laboratories, 2003.
9. D.A. Murdock, J.E. Ramos, J.J. Connors, and R.D. Lorenz, "Active Thermal Control of Power Electronics Modules," Industry Applications Conference, 38th IAS Annual Meeting, *Conference Record of Vol.3*, Oct. 12–16, 2003, pp. 1511–1515, 2003.
10. Z.J. Zuo, L.R. Hoover, and A.L. Phillips, "Advanced Thermal Architecture for Cooling of High-Power Electronics, *IEEE Transactions on Components and Packaging Technologies*, Vol. 25, pp. 629–634, 2002.
11. Q. Huang and B. Zhang, "Comparing SiC Switching Power Devices: MOSFET, NPN Transistor and GTO Thyristor," *Solid State Electronics* 44, pp. 325–340 (2000).
12. M. Chinthavali, L. M. Tolbert, and B. Ozpineci, "4H-SiC GTO Thyristor Loss Model for HVDC Converter," IEEE Industry Applications Society Annual Meeting, October 3–7, 2004, Seattle, Washington, 2004, pp. 1238–1243.
13. J. Gwinn and R.L. Webb, "Performance and Testing of Thermal Interface Materials," *Microelectronics Journal* 34, pp. 215–222 (2003).
14. J. Popovic and J.A. Ferreira, "An Approach to Deal with Packaging in Power Electronics," *IEEE Transactions on Power Electronics*, Vol. 20, No. 3, May 2005, pp.550–557.
15. E. Savrun, "Packaging Considerations for Very High Temperature Microsystems," *Proceedings of IEEE Sensors 2002*, Vol. 2, June 12–14, 2002, pp. 1130–1143.

## Chapter 7

1. A.C. Cotler, E.R. Brown, V. Dhir, and M.C Shaw, "Chip-Level Spray Cooling of an LD-MOSFET RF Power Amplifier," *IEEE Transactions on Components and Packaging Technologies* 27 (2), pp. 411–416 (2004).
2. S. Atcitty and W.I. Bower, *Power Electronics: Workshop on System Driven Approach for Inverter R&D*, April 23–24, 2003, Sandia National Laboratories, 2003.

3. D.A. Murdock, J.E. Ramos, J.J. Connors, and R.D. Lorenz, "Active Thermal Control of Power Electronics Modules," Industry Applications Conference, 38th IAS Annual Meeting, *Conference Record of Vol.3*, Oct. 12–16, 2003, pp. 1511–1515, 2003.
4. Z.J. Zuo, L.R. Hoover, and A.L. Phillips, "Advanced Thermal Architecture for Cooling of High-Power Electronics," *IEEE Transactions on Components and Packaging Technologies*, Vol. 25, pp. 629–634, 2002.
5. Q. Huang and B. Zhang, "Comparing SiC Switching Power Devices: MOSFET, NPN Transistor and GTO Thyristor," *Solid State Electronics* 44, pp. 325–340 (2000).
6. M. Chinthavali, L. M. Tolbert, and B. Ozpineci, "4H-SiC GTO Thyristor Loss Model for HVDC Converter," IEEE Industry Applications Society Annual Meeting, October 3–7, 2004, Seattle, Washington, 2004, pp. 1238–1243.
7. J. Gwinn and R.L. Webb, "Performance and Testing of Thermal Interface Materials," *Microelectronics Journal* 34, pp. 215–222 (2003).

## Appendix A. GLOSSARY

### Bandgap

Bandgap is the energy difference between the highest valence band and the lowest conduction band. Each semiconductor material has a unique bandgap. Figure A.1 shows a band structure of semiconductor.

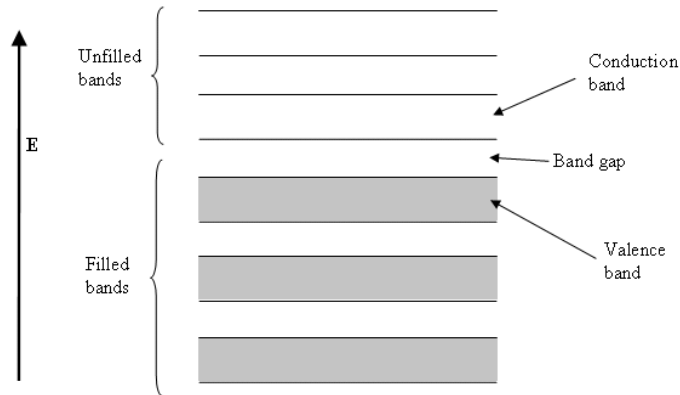


Fig. A.1. Semiconductor band structure.

### Battery Energy Storage System (BESS)

A chemical-based energy storage system using shunt connected, voltage sourced converters capable of rapidly adjusting the amount of energy which is supplied to or absorbed from an ac system.

### Bias (forward or reverse)

A voltage applied to a device or system so as to set its conditions of operation. A forward bias is the voltage applied in the direction of the current flow within a device. A reverse bias is voltage applied in the opposite direction. For a pn junction, forward bias decreases the resistance of the depletion layer and allows current to flow through the junction. Reverse bias increases the thickness of the depletion layer and allows only leakage current (minority carriers) to flow.

### Bipolar and Unipolar Devices

Bipolar devices are the devices in which both electrons and holes participate in the conduction, for example BJT, IGBT, or PN-diode. They are controlled by current. Unipolar devices have only one of these two particle types participate in the conduction and can be controlled by voltage, like MOSEFT or Schottky diode.

### Boules

A large mass of synthetically produced crystal material that usually describes semiconductor material before doping is applied.

### Breakdown (breakdown field, voltage)

In power devices, the voltage is supported across a depletion layer. The electric field across this layer is responsible for sweeping out any holes or electrons that enter this region. When the

voltage applied is increased, the electric field in the depletion region increases, and the mobile carriers are accelerated to higher velocities. When the electric field is large enough, ionized impact occurs, which is a multiplicative phenomenon that produces a cascade of mobile carriers which are transported through the depletion layer. This leads to an increase in the current flow through the depletion region. The device is considered to undergo avalanche breakdown when the rate of impact ionization approaches infinity because the device cannot support any further increase in the applied voltage. This reverse-bias applied voltage is called breakdown voltage, and the resultant electric field across the depletion layer is the breakdown field.

### **Convertible Series Compensators (CSC)**

The CSC is a FACTS concept that offers multiple compensation functions for power transmission systems. The CSC may be operated in different configurations. Depending on the configuration, the CSC is capable of simultaneously controlling voltage at an ac bus and changing real and reactive power flow in two ac transmission lines. What is unique about the CSC is that it can be used to transfer power back and forth between two lines, enabling the operator to maximize capacity utilization. (See Appendix B for more details.)

### **Current Limiter**

The current limiter is connected in series with a feeder such that it can restrict the current in case of a fault downstream.

### **Current Source Converter (CSC)**

A converter that is supplied by a direct current that always has one polarity, and the power reversal takes place through reversal of dc voltage polarity [1].

### **Distribution-STATCOM (D-STATCOM)**

The D-STATCOM technology, which consists of an IGBT-based voltage source inverter system, uses advanced power electronics to provide voltage stabilization, flicker suppression, power factor correction, harmonic control, and a host of other power quality solutions for both utility and industrial applications [2].

D-STATCOM is a shunt-connected device that has the same structure as that of a STATCOM. This can perform load compensation such as power factor correction, harmonic filtering, load balancing etc. when connected at the load terminals. It can also perform voltage regulation when connected to a distribution bus [3]. (See Appendix B for more details.)

### **Doping**

The process of adding impurities to silicon such as boron and phosphorus to alter silicon's conductivity properties.

### **Drift Region and Drift Region Resistance**

A thick, lightly doped layer in power semiconductor devices which blocks voltage when reverse biased is termed the drift region. The resistance of this region is called drift resistance, which determines the voltage drop and power loss when the device is in its conduction mode.

## **Drift Velocity**

Drift velocity is the velocity of carriers in semiconductor under the influence of electric field, and their velocity is determined by the mobility of carriers.

## **Dynamic Voltage Limit**

The objective of dynamic voltage stability is achieved by minimizing oscillations of the state and network variables. Then a parameter optimization technique is applied for limiting the magnitude of oscillations. The dynamic voltage limit is determined by detecting dynamic voltage collapse based on dynamic modeling of generators, governors, switched capacitors and loads.

## **Electronic Fence**

The concept of an electronic fence is an attempt by a utility to protect its property rights by preventing another utility from using its transmission system. This is analogous to a physical fence keeping trespassers from passing through an individual's property. In the case of the electronic fence, there are a limited number of access points, these being the tie-lines connecting the utility to its neighbors. In the analogous case, consider an area that can only be accessed along certain paths [4].

## **Epitaxial Growth**

The growth of crystals of one material on the crystal face of another or the same material, such that the two materials have a defined, relative structural orientation.

## **Extrinsic Properties**

A property that depends on an object's relationship with other things.

## **Flexible AC Transmission Systems (FACTS)**

Alternating current transmission systems incorporating power electronic-based and other static controllers to enhance controllability and increase power transfer capability.

## **Gate and Gate Voltage**

Gate is the element that acts as a trigger to cause the transistor to switch ON or OFF. In a bipolar device, it is sometimes called a base. When there is no voltage on gates or bases in a normally-off device, then the device is non-conductive (no current flow). When proper voltage or current requirements are met, the devices become conductive and current flows from input to output. A gate control circuit is required to generate proper control signals.

## **High Voltage DC Transmission (HVDC)**

The HVDC technology is used to transmit electricity over long distances by overhead transmission lines or submarine cables. It is also used to interconnect separate power systems, where traditional alternating current (AC) connections cannot be used.

## **HVDC Light**

Trademark name of ABB technology that uses new cable and IGBT-based converter technologies and is economical at lower power levels than traditional HVDC.

## **Inadvertent Loop Flow Limit**

Steady-state power transmission may also be limited by the so-called *parallel* and *loop* power flows. These flows often occur in a multi-line, interconnected power system, as a consequence of basic circuit laws which define current flows by the impedance rather than the current capacity of the lines. They can result in overloaded lines with thermal and voltage level problems [5].

## **Insulated Gate**

It is a gate concept based on a combination of the physics of bipolar current conduction with MOS gated current control within the same semiconductor region.

## **Inter-Phase Power Flow Controller (IPFC) [1]**

The combination of two or more SSSC which are coupled via a common dc link to facilitate bi-directional flow of real power between the ac terminals of the SSSC, and are controlled to provide independent reactive compensation for the adjustment of real power flow in each line and maintain the desired distribution of reactive power flow among the lines.

## **Intrinsic Properties**

A property that an object has of itself, independently of other objects, including its contents.

## **Mobility**

It is the proportionality factor between semiconductor conductivity and concentration of charge carriers. It is different for different semiconductors due to the difference in the effective mass and mean free time of charge carriers in different semiconductors. A higher mobility makes the material easier to conduct current.

## **Passive and Active Component**

A passive component is an electronic component that does not require a source of energy to perform its intended function. Examples of passive components include resistors, capacitors, inductors, transformer, and electrical fuses. An active component is an electronic device that requires a source of energy to perform its intended function. It usually has gain or directs the flow of current in a circuit. Example: transistors, thyristors, and diodes.

## **PN Junctions**

A *pn* junction is formed when an *n*-type doped region in a silicon crystal is adjacent to or abuts a *p*-type doped region in the same crystal.

## **Power System Oscillation Damping Limit**

In the case of an under-damped power system, any minor disturbance can cause the machine angle to oscillate around its steady-state value at the natural frequency of the total electromechanical system. The angle oscillation, of course, results in a corresponding power oscillation around the steady-state power transmitted. The lack of sufficient damping may be the limiting factor for the transmittable power. For power oscillation damping it is necessary to vary the applied compensation so as to counteract the accelerating and decelerating swings of the disturbed machines [1].



## Pulse Width Modulation (PWM)

A modulation technique that generates variable-width pulses to represent the amplitude of an analog input signal such as a sine wave. The output switching transistor has two states: on or off. It is on more of the time for a high-amplitude signal and off more of the time for a low-amplitude signal.

## Regenerative Action

In a thyristor structure, an on-state current conduction can occur without need for any gate drive because the two transistors inside can provide the base drive currents for each other. This mode of operation is referred to as regenerative action.

## Reverse Biased Second Breakdown (or RBSOA)

For power bipolar transistors, they are susceptible to a different failure mechanism called second breakdown during turn-off. This limitation to its safe-operating-area is referred to as reverse biased second breakdown or RBSOA because the base drive current is reversed during turn-off.

## Reverse Recovery

Reverse recovery is the process whereby a diode is switched from its on-state to its reverse blocking state (off-state). To undergo this transition, minority carrier charge stored in the drift region must be removed. The removal of the stored charges occurs via two phenomena, namely, the flow of a large reverse current and internal recombination. The portion of stored charges swept out by the reverse current is called reverse recovery charge. The reverse current is called reverse recovery current. The typical current flow and voltage response during this period is shown in Fig. A.2.  $t_{rr}$  is the reverse recovery time. A large magnitude and time duration of reverse recovery current leads to additional switching losses in inverters and converters.

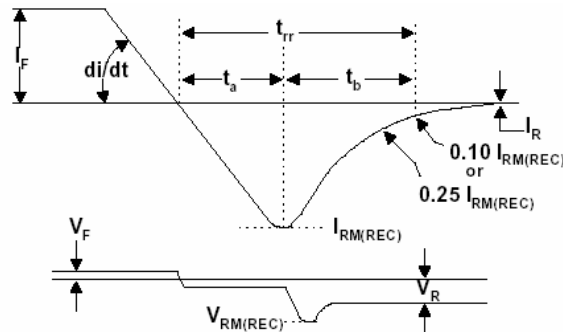


Fig. A.2. The typical current flow and voltage response of a diode.

## Self-Commutated vs. Line-Commutated

For power devices, “commutate” means the transition between on- and off-state. It is similar to “switch”. “Self-commutated” means that a device can be turned off by controlling its gate signal (MOSFET, IGBT). Line-commutated means that a device can not be turned off by signal applied on itself and has to be switched via an AC grid voltage (diode, thyristor, GTO).

## **Series Compensation (SC)**

The basic idea behind series capacitive compensation is to decrease the overall effective series transmission impedance from the sending-end to the receiving-end so that net power transfer can be increased.

## **Short Circuit Current Limit**

This is the interrupting limit of a protective device (fuse or circuit breaker). These protective devices will not suffer damage and should be able to open a fault below this limit. Currents above this limit will damage the protective device and it may not be able to interrupt the fault.

## **Snubber Circuit**

A snubber circuit is a simple electrical circuit used to suppress (“snub”) electrical transients. Snubbers are frequently used in inverters or converters with an inductive load where the sudden interruption of current flow would lead to a sharp rise in voltage across the device creating the interruption. This sharp rise in voltage might lead to a transient or permanent failure of the controlling device.

## **Static Var Compensation (SVC)**

A shunt-connected static var generator or absorber whose output is adjusted to exchange capacitive or inductive current so as to maintain or control specific parameters of the electrical power system (typically bus voltage). (See Appendix B for more details.)

## **Static Synchronous Generator (SSG)**

A static, self-commutated switching power converter supplied from an appropriate electric energy source and operated to produce a set of adjustable multi-phase output voltages, which may be coupled to an ac power system for the purpose of exchanging independently controllable real and reactive power.

## **Static Synchronous Compensator (STATCOM)**

A static synchronous generator operated as a shunt-connected static var compensator whose capacitive or inductive output current can be controlled independent of the ac system voltage. (See Appendix B for more details.)

## **Static Synchronous Series Compensator (SSSC)**

A static, synchronous generator operated without an external electric energy source as a series compensator whose output voltage is in quadrature with, and controllable independently of, the line current for the purpose of increasing or decreasing the overall reactive voltage drop across the line and thereby controlling the transmitted electric power. The SSSC may include transiently rated energy storage or energy absorbing devices to enhance the dynamic behavior of the power system by additional temporary real power compensation, to increase or decrease momentarily, the overall real (resistive) voltage drop across the line. (See Appendix B for more details.)

## **Steady State Power Transfer Limit**

This limit is defined as the voltage at the sending-end multiplied by the voltage at the receiving-end and then divided by the impedance between sending-end and receiving-end.

## **Superconducting Magnetic Energy Storage (SMES)**

A superconducting electromagnetic energy storage device containing electronic converters that rapidly injects and/or absorbs real and/or reactive power or dynamically controls power flow in an ac system.

## **Thermal Limit**

The maximum allowable flow in amps or MVA on a transmission line or transformer without exceeding the current carrying capability of the facility. Current rating may differ for short term and long term loading sequences and may vary with ambient temperature. A full AC load flow study or a fast DC load flow can detect thermal limit problems [5].

## **Thyristor Controlled Series Compensation (TCSC)**

A capacitive reactance compensator which consists of a series capacitor bank shunted by a thyristor controlled reactor in order to provide a smoothly variable series capacitive reactance. (See Appendix B for more details.)

## **Thyristor Controlled Phase Shifting Transformer (TCPST)**

A phase-shifting transformer adjusted by thyristor switches to provide a rapidly variable phase angle.

## **Transient Stability Limit**

The maximum allowable flow in amps or MVA on a line or across a transmission path such that loss of a transmission element due to a fault does not result in generator instability. Only a complex stability study can detect a transient stability limit problem [5].

## **Unified Power Flow Controllers (UPFC)**

A combination of a static synchronous compensator (STATCOM) and a static synchronous series compensator (SSSC) which are coupled via a common dc link, to allow bi-directional flow of real power between the series output terminals of the SSSC and the shunt output terminals of the STATCOM, and are controlled to provide concurrent real and reactive series line compensation without an external electric energy source. The UPFC, by means of angularly unconstrained series voltage injection, is able to control, concurrently or selectively, the transmission line voltage, impedance, and angle or, alternatively, the real and reactive power flow in the line. The UPFC may also provide independently controllable shunt reactive compensation. (See Appendix B for more details.)

## **Valve**

A collection of series connected thyristor and reactor modules.

## Voltage Source Converter (VSC)

An inverter fed from a dc voltage that always has one polarity, and the power reversal takes place through reversal of dc current polarity [2].

## Voltage Stability Limit

The maximum allowable flow in amps or MVA on a line or across a transmission path such that loss of a transmission element due to a fault does not result in either a rapid voltage collapse or a slow voltage recovery. Only a complex stability study can detect a voltage stability limit problem [5]. The voltage stability can be illustrated using the so-called “P-V nose curve” on which the “nose point” given for a specific compensation level represents the corresponding voltage stability limit.

## Wheeling

The term describes the transfer of power among three or more utilities. Assume utility one is directly connected to utility two, utility two is directly connected to utility three, and utility one is not directly connected to utility three. Utility one consumes more power than it can generate. Utility one requires power to be transferred from an adjacent utility, but the adjacent utility two cannot supply the required amount for utility one. Utility three can supply the required amount for utility one; therefore, utility two can transfer without consuming the power or “wheel” the power from utility three to utility one.

## References

1. N. G. Hingorani and L. Gyugyi, *Understanding FACTS: Concepts and Technology of Flexible ac Transmission Systems*, IEEE Press, 2000.
2. G. F. Reed, “Application of a 5 MVA, 4.16 kV D-STATCOM System for Voltage Flicker Compensation at Seattle Iron and Metals.”
3. A. Ghosh and G. Ledwich, *Power Quality Enhancement Using Custom Power Devices*, Kluwer Academic Publisher, 2002.
4. D. J. Gotham and G. T. Heydt, “Power Flow Control and Power Flow Studies for Systems with FACTS Devices,” *IEEE Transactions on Power Systems*, Vol. 13, 1998, pp. 60–65.
5. Y. Song and A. T. Johns, *Flexible ac Transmission Systems*, IEE Power and Energy Series, 1999.

## Appendix B. PRINCIPLES OF OPERATION FOR FACTS DEVICES AND HVDC

### B.1 Benefits of Control of Power Systems [1]

Once power system constraints are identified and, through system studies, viable solutions are identified, the benefits of the added power system control using flexible ac transmission systems (FACTS) must be determined. As listed in Chapter 1, some of these benefits include:

- Increased loading and more effective use of transmission corridors
- Added power flow control
- Improved power system stability
- Increased system security
- Increased system reliability
- Added flexibility in siting new generation facilities
- Elimination or deferral of the need for new transmission lines

To justify the costs of implementing added power system control and to compare conventional solutions to FACTS controllers, more specific metrics of the benefits to the power system are often required. Such benefits can usually be tied back to an area or region for a specific season and year at a defined dispatch, usually given by an ISO or equivalent, while meeting the following criteria, for example:

- Voltage Stability Criteria  
e.g., P-V voltage or power criteria with minimum margins  
e.g., Q-V reactive power criteria with minimum margins
- Dynamic Voltage Criteria  
e.g., Avoiding voltage collapse  
e.g., Minimum transient voltage dip/sag criteria (magnitude and duration)
- Transient Stability Criteria
- Power System Oscillation Damping  
e.g., Minimum damping ratio
- Others

Each of the above-listed items can usually be measured in terms of a physical quantity such as power transfer through a critical transmission interface, power plant output, and/or area or region load level. This allows for a direct quantification of the benefits of adding power system control and provides a means to compare such benefits by the various solution options considered, whether they are conventional or FACTS based.

Tables B.1 and B.2 describe the technical benefits of the principal FACTS devices including steady state applications in addressing problems of voltage limits, thermal limits, loop flows, short circuit levels, and sub-synchronous resonance. For each problem the conventional solution (e.g. shunt reactor or shunt capacitor) is also provided as well as dynamic applications of FACTS in addressing problems in transient stability, dampening, post contingency voltage control and voltage stability. FACTS devices are required when there is a need to respond to dynamic (fast-changing) network conditions. The conventional solutions are normally less expensive than FACTS devices—but limited in their dynamic behavior. Moreover, usually one FACTS device can solve several problems, which would otherwise need to be solved by several different

**Table B.1. Steady state application of FACTS [4]**

Issue	Problem	Corrective action	Conventional solution	FACTS device
Voltage limits	Low voltage at heavy load	Supply reactive power	Shunt capacitor, Series capacitor	SVC, TCSC, STATCOM
	High voltage at light load	Remove reactive power supply Absorb reactive power	Switch EHV line and/or shunt capacitor Switch shunt capacitor, shunt reactor	SVC, TCSC, STATCOM SVC, STATCOM
	High voltage following outage	Absorb reactive power Protect equipment	Add shunt reactor Add arrester	SVC, STATCOM SVC
	Low voltage following outage	Supply reactive power	Switch shunt capacitor, reactor, series capacitor	SVC, STATCOM
	Low voltage and overload	Prevent overload Supply reactive power and limit overload	Series reactor, PAR Combination of two or more devices	TCPAR, TCSC TCSC, UPFC, STATCOM, SVC
Thermal limits	Line or transformer overload	Reduce overload	Add line or transformer Add series reactor	TCSC, UPFC, TCPAR SVC, TCSC
	Tripping of parallel circuit (line)	Limit circuit (line) loading	Add series reactor, capacitor	UPFC, TCSC
Loop flows	Parallel line load sharing	Adjust series reactance Adjust phase angle	Add series capacitor/reactor Add PAR	UPFC, TCSC TCPAR, UPFC
	Post-fault sharing	Rearrange network or use "Thermal limit" actions	PAR, Series Capacitor/Reactor	TCSC, UPFC, SVC, TCPAR
	Flow direction reversal	Adjust phase angle	PAR	TCPAR, UPFC
Short circuit levels	Excessive breaker fault current	Limit short circuit current	Add series reactor, new circuit breaker	SCCL, UPFC, TCSC
		Change circuit breaker	Add new circuit breaker	
		Rearrange network	Split bus	
Subsynchronous resonance	Potential turbine/generator shaft damage	Mitigate oscillations	Series compensation	NGH, TCSC

Legend

NGH = Hingorani damper	TCSC = Thyristor-controlled series capacitor
PAR = Phase-angle-regulator	TCVL = Thyristor-controlled voltage limiter
SCCL = Superconducting current limiter	TSBR = Thyristor-switched braking resistor
SVC = Static Var compensator	TSSC = Thyristor-switched series capacitor
STATCOM = Static compensator	UPFC = Unified power flow controller
TCPAR = Thyristor-controlled phase-angle regulator	

**Table B.2. Dynamic applications of FACTS [5]**

Issue	Type of system	Corrective action	Conventional solution	FACTS device
Transient stability	A, B, D	Increase synchronizing torque	High-response exciter, series capacitor	TCSC, TSSC, UPFC
	A, D	Absorb kinetic energy	Braking resistor, fast valving (turbine)	TCBR, SMES, BESS
	B, C, D	Dynamic load flow control	HVDC	TCPAR, UPFC, TCSC
Dampening	A	Dampen 1 Hz oscillations	Exciter, Power system stabilizer (PSS)	SVC, TCSC, STATCOM
	B, D	Dampen low frequency oscillations	Power system stabilizer (PSS)	SVC, TCPAR, UPFC, NGH, TCSC, STATCOM
Post-contingency voltage control	A, B, D	Dynamic voltage support	—	SVC, STATCOM, UPFC
		Dynamic flow control	—	SVC, UPFC, TCPAR
		Dynamic voltage support and flow control	—	SVC, UPFC, TCSC
	A, B, C, D	Reduce impact of contingency	Parallel lines	SVC, TCSC, STATCOM, UPFC
Voltage stability	B, C, D	Reactive Support	Shunt capacitor, shunt reactor	SVC, STATCOM, UPFC
		Network control actions	LTC, reclosing, HVDC controls	UPFC, TCSC, STATCOM
		Generation control	High-response exciter	—
		Load control	Under-voltage load shedding Demand-Side Management Programs	—

**Legend**

A. Remote generation—radial lines	B. Interconnected areas
C. Tightly meshed network	D. Loosely meshed network (e.g. Queensland, Austr.)
BESS = battery energy storage system	UPFC = Unified power flow controller
HVDC = High-voltage direct current	SVC = Static Var compensator
LTC = Transformer-load tap changer	TCPAR = Thyristor-controlled phase-angle regulator
NGH = Hingorani damper	TCSC = Thyristor-controlled series capacitor
PAR = Phase-angle regulator	TCVL = Thyristor-controlled voltage limiter
SCCL = Superconducting current limiter	TSBR = Thyristor-switched braking resistor energy storage
SMES = Superconducting magnetic	TSSC = Thyristor-switched series capacitor
STATCOM = Static synchronous compensator	

conventional solutions. Thus, we can conclude that FACTS devices are more flexible than most conventional solutions.

Transient stability studies involve large disturbances such as transmission system faults, sudden load changes, loss of generating units, and line switching, which focus on the first-swing rather than a multi-swing basis. Usually, the time period under study is the first second following a system fault or other large disturbance. Following a large disturbance, if the machines of the system attain a significantly different but acceptable steady-state operating condition within the first second, then the machines still remain essentially in synchronism, and the system is regarded as being transiently stable [2]. The problem of studying the stability of synchronous machines under the condition of small load changes has been called “steady-state” stability. A more recent and certainly more appropriate name is dynamic stability [3].

In Tables B.1 and B.2, information is provided on FACTS devices with extensive operational experience and widespread use such as static Var compensators (SVCs), STATCOM, thyristor-controlled series capacitors (TCSCs) and unified power flow controllers (UPFCs). In addition, information is provided on FACTS devices that are either under discussion, under development or in prototype operation such as the thyristor-controlled phase-angle regulator (TCPAR), the thyristor-controlled voltage limiter (TCVL), and the TCSC.

## B.2 Static Var Compensator

### Subcategories of an SVC

- TCR = thyristor-controlled reactor
- TSR = thyristor-switched reactor
- TSC = thyristor-switched capacitor
- MSC = mechanically-switched capacitor
- MSR = mechanically-switched reactor
- FC = fixed capacitor
- Harmonic filters

The SVC uses the conventional thyristor to achieve fast control of shunt connected capacitors and reactors. The SVC provides a rapid and fine control of voltage without moving parts and is readily available in the current market. The TCR portion of SVC consists of anti-parallel thyristors in series with shunt reactors usually in a delta configuration. These thyristors may be switched at any point over the half wave (90 to 180 electrical degrees behind the voltage wave) to provide a fully adjustable control from 100 % to zero reactive power absorption. Harmonic currents are generated at any angle other than 90 (full conduction) and 180 (zero conduction). TSR or TSC configurations are also used which have only two states of operation—zero or full conduction [5]. Figure B.1 shows the basic circuit for an SVC. Figure B.2 shows its voltage-current characteristics.

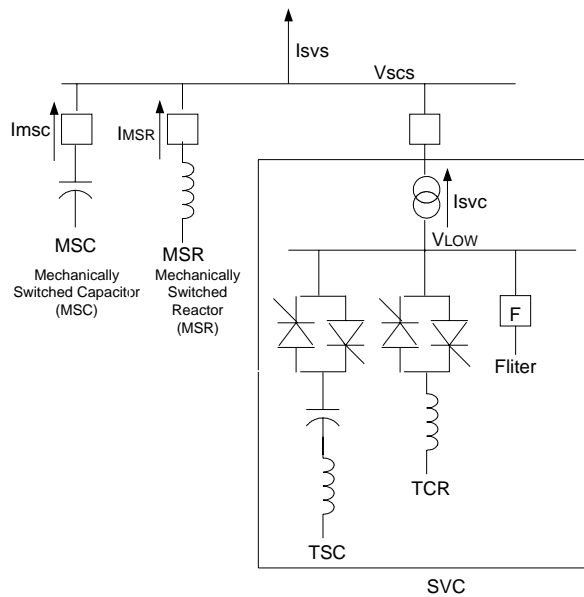


Fig. B.1. Circuit for an SVC [1].

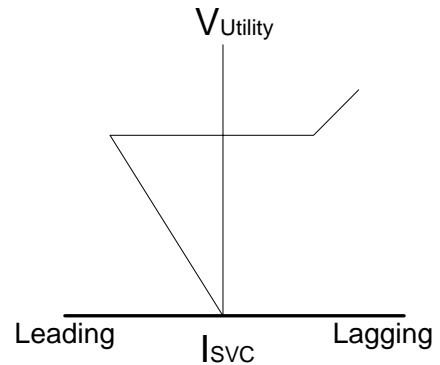


Fig. B.2. V-I characteristics of an SVC [1].



Functions that may be incorporated into SVC controls include the following [6]:

- Damping of system swings
- Non-linear gain—to increase response during large disturbances
- TCR  $\Delta$  winding dc current elimination
- Negative sequence balancing
- TCR overcurrent protection
- Secondary overvoltage protection

### **SVC cost and project list (in the United States)**

In the 115–230 kV range, SVCs typically operate in ranges of 0–100 MVar inductive and 100–200 MVar capacitive, and cost \$5 million to \$10 million. At higher voltages, SVCs range from 300 MVar inductive to 500 MVar capacitive, and cost \$10 million to \$15 million. Smaller SVCs can change output in a few milliseconds. Larger SVCs can make small changes quickly, but may take a few seconds to make larger changes. Output from SVCs can be varied continuously—they do not require the discharge time needed for switched capacitor banks. There are more than 50 SVCs, installed in the United States, as shown in Table B.3, ranging from 30 to 650 MVar each [7].

**Table B.3. SVC installation list in the United States [8,9]**

Number	Year	Customer	Location	Voltage	Control range	Remarks
Siemens SVC sample list (in the U.S.)						
1	1990	Southwestern Public Service Company, Amarillo, Texas	Eddy County Substation	230/8.5 kV	50/100 Mvar	PSDC, VC, ISS
2	1993	WSCC Department of Water and Power, Los Angeles	Marketplace Substation	500/16.8 kV	0/388 Mvar	PSDC, VC
3	1993	WSCC Department of Water and Power, Los Angeles	Adelanto Switching Station	500/16.8 kV	0/388 Mvar	PSDC, VC
ABB SVC project list (in the U.S.)						
1	1974	Auburn Steel	Auburn, New York	14 kV	-35/35 Mvar	Both
2	1976	Ameron Steel & Wire	Etiwanda, Calif	33 kV	- 65/65 Mvar	Both
3	1978	Minn Power Light	Duluth, Minnesota	14 kV	-40/40 Mvar	Utility
4	1980	Lukens Steel Co	Coatesville, Penn	14 kV	-100/100 Mvar	Both
5	1980	Florida Steel Corp	Croft, N.C.	13 kV	-60/60 Mvar	Both
6	1980	Publ Serv of New Mexico	Farmington, N Mex	11 kV	-30/30 Mvar	Utility
7	1980	Publ Serv of New Mexico USA	Farmington, N Mex	11 kV	-30/30 Mvar	Utility
8	1980	AEP USA	Beaver Creek	138 kV	-250/450 Mvar	Utility
9	1981	EPRI Contract	Butte, Montana	12 kV	-9/9 Mvar	Customer
10	1981	Bethlehem Steel Co	Johnstown, Penn	35 kV	-125 /125 Mvar	Both
11	1981	Structural Metals Inc	Seguin, Texas	13 kV	-60 /60 Mvar	Both
12	1981	Bethlehem Steel Co	Johnstown, Penn	35 kV	-125 /125 Mvar	Both
13	1982	Cathedral Bluffs Shale	Rifle, Colorado	13 kV	-15 /15 Mvar	Customer
14	1984	Timken Company	Canton, Ohio	35 kV	-85 /85 Mvar	Both
15	1984	Westingh Transp Div	West Mifflin, Penn	4 kV	-10 /10 Mvar	Customer
16	1984	Tucson Electr Power Co	Tucson, Arizona	11 kV	-30 /30 Mvar	Utility
17	1984	Plains Electr G&T Coop	Clapham, N Mex	13 kV	-50 /50 Mvar	Utility
18	1986	Kansas Gas & El Co	Murray Gill	138 kV	-225 /225 Mvar	Utility
19	1986	Kansas Gas & El Co	Gordon Evans USA	138 kV	-300 /300 Mvar	Utility
20	1988	Nucor Steel	Indiana	35 kV	-140 /140 Mvar	Both
21	1988	Nucor Steel	Indiana	35 kV	-80 /80 Mvar	Both
22	1988	Tucson Electr Power Co	Tucson, Arizona	11 kV	-30 /30 Mvar	Utility
23	1988	WAPA	Fargo USA	14 kV	-65 /65 Mvar	Utility
24	1988	Niagara Mohawk	Leeds	345 kV	-570/600 Mvar	Utility
25	1988	NYSEG	Fraser, New York	345 kV	-625 /625 Mvar	Utility
26	1989	Marion Steel	Marion, Ohio	14 kV	-50 /50 Mvar	Both

**Table B.3. (continued)**

Number	Year	Customer	Location	Voltage	Control range	Remarks
27	1989	Tippins/Sydney Steel	Nova Scotia Can.	35 kV	-140 /140 Mvar	Both
28	1989	Empire Detroit	Mansfield	35 kV	-90 /90 Mvar	Both
29	1989	Jersey Central P&L	Atlantic	230 kV	-130 / 390 Mvar	Utility
30	1990	Keystone Steel and Wire	Peoria	34 kV	-165 /165 Mvar	Both
31	1990	MEPCO	Chester USA	345 kV	-550 /565 Mvar	Utility
32	1992	Nucor	Blytheville, AR III	34 kV	-195 /195 Mvar	Both
33	1992	Nucor	Blytheville, Ar IV	34 kV	-65 /65 Mvar	Both
34	1992	AEA	Daves Creek	115 kV	-35 /35 Mvar	Utility
35	1992	AEA	Soldatna USA	115 kV	-110 /110 Mvar	Utility
36	1993	BPA	Keeler USA	230 kV	-650 /650 Mvar	Utility
37	1993	BPA	Maple Valley	230 kV	-650 /650 Mvar	Utility
38	1994	North. States Power	Forbes S/S	500 kV	-200 /800 Mvar	Utility
39	1995	North Star	West Coast Steel plant	35 kV	-95 /95 Mvar	Both
40	1996	Tuscaloosa Steel	Tuscaloosa	35 kV	-110 /110 Mvar	Both
41	1996	LANL	Los Alamos	115 kV	-150 /150 Mvar	Utility
42	1997	Nucor	Nucor, Nebraska	35 kV	-106 /106 Mvar	Both
43	1997	Virginia Power	Colington	115 kV	-108 /216 Mvar	Utility
44	2000	Black & Veatch, Connectiv	Nelson, Delaware	138 kV	-250 /250 Mvar	Utility
45	2000	Connectiv	Indian River, Delaware	230 kV	-250 /300 Mvar	Utility
46	2000	CSW	Eagle Pass B2B	138 kV	-50 /50 Mvar	Utility
47	2002	Cascade Steel	Cascade Steel	34 kV	-90 /90 Mvar	Both
48	2002	PG & E	Newark USA	230 kV	-300 /300 Mvar	Utility
49	2003	Connectiv	Cardiff, N Jersey	230 kV	-250 /250 Mvar	Utility
50	2004	Allegheny-Ludlum	Allegheny- Ludlum	25 kV	0/110 Mvar	Both
51	2004	PG&E	Potrero USA	115 kV	0/340 Mvar	Utility
52	2005	GVEA Alaska	Jarvis Creek	138 kV	0/44 Mvar	Utility

Legend for Table B.3:

PSDC: Power System Damping Control

EAF: Electrical Arc Furnaces

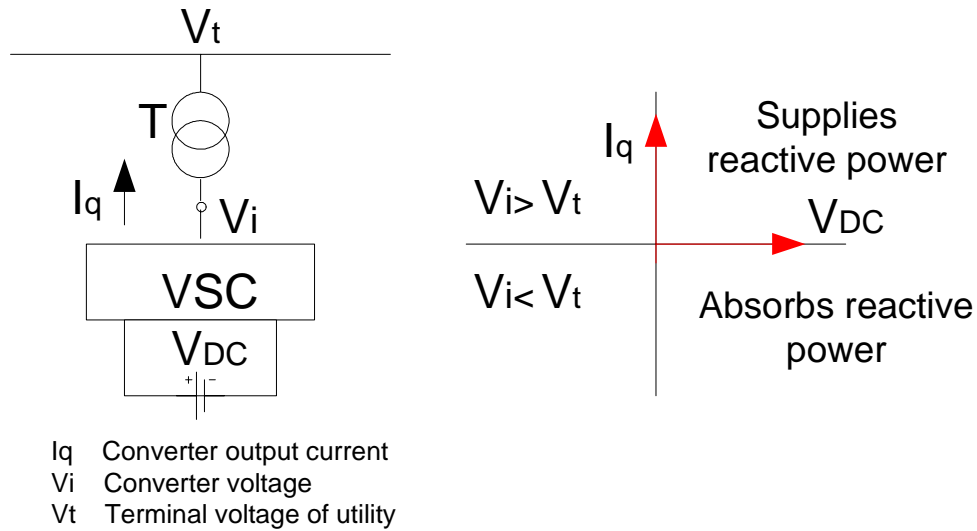
ISS: Improve System Stability

VC: Voltage Control

### B.3 Static Synchronous Compensator (STATCOM)

#### Principle of operation

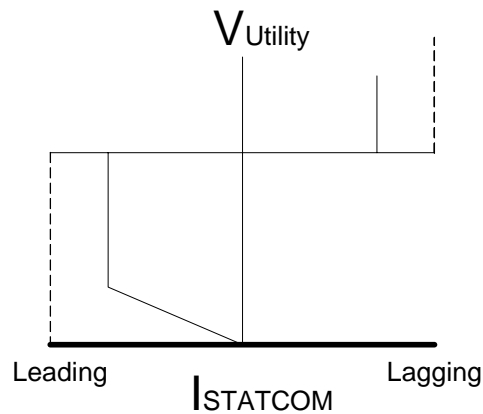
A static compensator consists of a voltage source converter, a coupling transformer and controls. In this application the dc energy source device can be replaced by a dc capacitor, so that the steady-state power exchange between the static compensator and the ac system can only be reactive, as illustrated in Fig. B.3. Here  $I_q$  is the STATCOM converter output current, perpendicular to the converter voltage  $V_i$ . The magnitude of the converter voltage, and thus the reactive output of the converter, is controllable. If  $V_i$  is greater than the terminal voltage,  $V_t$ , the static compensator will supply reactive power to the ac system. If  $V_i$  is smaller than  $V_t$ , the static compensator absorbs reactive power [10].



**Fig. B.3. STATCOM operation principle [10].**

### Characteristics

The application of a static synchronous generator to regulate reactive power and/or ac voltage magnitude is called STATCOM or static Var generator. The reactive power of a STATCOM can be adjusted continuously from 100% inductive (lagging) to 100% capacitive (leading) as shown in Fig. B.4, by controlling the internal voltage magnitude  $V_i$ . This implies that the control range of output of STATCOM is twice as wide as that of SVC of the same rating and the output is independent of the system voltage, unlike the SVC, whose output voltage is dependent on the system voltage; this is a key difference between the SVC and STATCOM. ac output current of STATCOM can be kept constant by controlling the ac output voltage while the utility voltage drops substantially.



**Fig. B.4. V-I characteristics of a STATCOM [1].**

The STATCOM can produce negative sequence output voltage in addition to positive sequence output voltage by controlling independently the magnitude and phase angle of each phase output voltage. Consequently, the negative sequence component included in ac current can be reduced by adjusting the magnitude and the phase angle of the negative sequence component of the STATCOM output voltage, even when negative sequence component is included in the utility system voltage [5].

The STATCOM certainly has the potential to [11]:

- Maintain its reactive current at low voltage since it has an essentially constant current characteristic while a thyristor SVC has constant impedance (Figure B.2).
- Reduce real estate use to about 40% of a thyristor SVCs requirement
- Store energy, if batteries replace capacitors.
- Be applied as an active filter because each step can be switched in response to a harmonic.

### Installation list

The first large-scale STATCOM FACTS controller was deployed in 1991 in Japan and in 1995 in the US. It built on earlier power equipment–SVC by adding thyristor controls (gate turnoff thyristors, or GTOs). Recent advances by Mitsubishi Electric in the mid-1990s led to the development and recent applications of an advanced power semiconductor technology known as the gate commutated turnoff thyristor, or GCT, which has lead to vast improvements in performance and reliability, and significant reductions in operating losses [12].

STATCOM devices are manufactured by a number of the major electric equipment companies, including ABB, Alstom, Mitsubishi, and Siemens. SVC and STATCOM maintenance costs are higher than capacitor banks, but much less than generators. STATCOMs are installed at several sites in the United States (Table B.4), ranging between 30 and 100 MVar each [7].

**Table B.4. STATCOM installations sample (in the United States)**

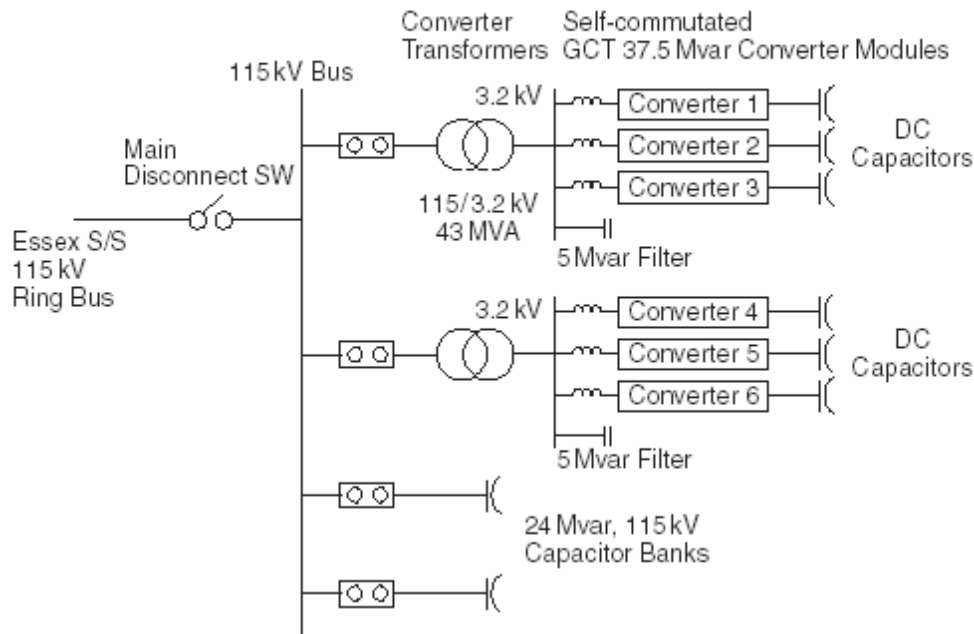
Number	Year	Customer	Location	Voltage	Control range	Remarks	Supplier
1	1995	Tennessee Valley Authority (TVA)	Sullivan Substation (Johnson City, Tennessee)	161kV	±100MVar	GTO thyristor valves	Westinghouse Electric Corporation
2	2000	American Electric Power (AEP)	Eagle Pass Station (Texas)	138 kV	±36 MVar	Back to Back scheme	ABB
3	2001	Vermont Electric Power	Essex station (Burlington, Vermont)	115kV	–41 to +133MVar	Gate Commutated Turn-Off Thyristor (GCT)	Mitsubishi
4	–	Central & South West Services (CSWS)	Laredo and Brownsville stations (Texas)	—	±150MVar	—	W-Siemens
5	2003	San Diego Gas & Electric (SDG&E)	Talega station (Southern California)	138 kV	±100MVar	Gate Commutated Turn-Off Thyristor (GCT)	Mitsubishi
6	2003	Northeast Utilities (NU)	Glenbrook station (Hartford, Connecticut)	115 kV	±150MVar		Areva (Alstom)
7	2004	Austin Energy	Holly (Texas)	138 kV	–80 to +110 MVar	IGBT based STATCOM	ABB

## Project highlights [13]

### VELCO Essex STATCOM-Based FACTS Project

Project Name	VELCO Essex STATCOM-Based FACTS Project
Commissioned	May 2001
Location	Essex Substation near Burlington, Vermont, USA
Dynamic Rating	-41 to +133Mvar
System Voltage	115 kV-ac
Converter Type	3-Level Voltage Sourced Converter Design
Configuration	6 Converter Sets in Parallel
GCT Ratings	6-kV/6-kA (6 inch-diameter)
Control	Coordinated control with local and remote capacitor banks

The Essex S/S FACTS was installed to compensate for heavy increases in summertime electric usage, which have rendered the existing system increasingly vulnerable to failure in the event of problems elsewhere on the VELCO transmission system. The FACTS at Essex is designed as a shunt-connected static reactive compensator (STATCOM) System. The VELCO system requirements (i.e., the purpose of the STATCOM) can be categorized as dynamic reactive compensation needed for fast voltage support during critical contingencies. The STATCOM system also provides enhanced power quality indirectly to a nearby industrial manufacturing facility that is sensitive to voltage disturbances at Essex. A schematic of this system is shown in Fig. B.5.



Source: Mitsubishi Electric Power Products

**Fig. B.5. VELCO Essex S/S -41/+133Mvar, 115kV STATCOM System [13].**

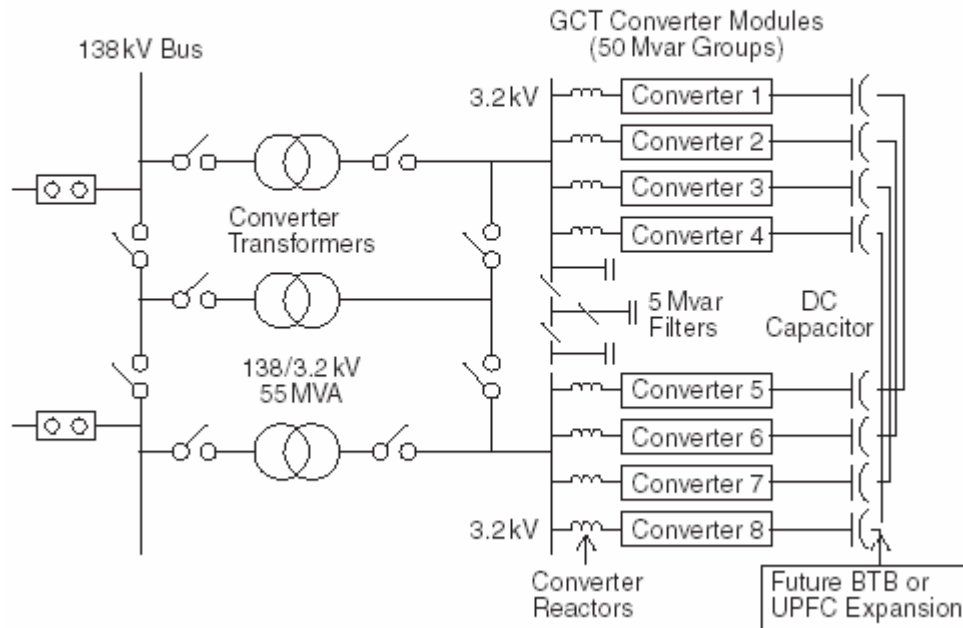
The main objectives of the Essex STATCOM system are as follows:

- a. Rapid response to system disturbances
- b. Smooth control of ac voltage over a wide range of operating conditions
- c. Improved system reliability and local power quality through dynamic voltage support
- d. High reliability with redundant parallel converter design and modular construction

**SDG&E Talega STATCOM / B2B FACTS Project [14]**

Project Name	SDG&E Talega STATCOM / B2B FACTS Project
Commissioned	February 2003
Location	Talega Substation near San Clemente, California, USA
Dynamic Rating	-100 to +100Mvar (STATCOM) 50 MW (future B2B dc-Link)
System Voltage	138 kV-ac
Converter Type	3-Level Voltage Sourced Converter Design
Configuration	8 Converter Sets in Parallel
GCT Ratings	6-kV/6-kA (6 inches)
Control	Volt-Var Switchable Control

The FACTS installed in the SDG&E system at the Talega 138 kV substation is being applied to relieve transmission system constraints in the area through dynamic var control during peak load conditions. It is operating as a STATCOM with a rated dynamic reactive capacity of  $\pm 100$ Mvar. A schematic of this system is shown in Fig. B.6.



Source: Mitsubishi Electric Power Products

**Fig. B.6. SDG&E Talega -100/+100 Mvar, 138 kV STATCOM / B2B System [14].**

The main objectives of the Talega STATCOM are as follows:

- a. Regulation and control of the 138 kV ac system voltage
- b. Dynamic, fast response reactive power support following system contingencies
- c. High reliability with redundant parallel converter design & modular construction
- d. Operational flexibility through auto-reconfiguration design

The Talega FACTS is also designed for future operation as a B2B dc-link. The B2B system would have a power transfer rating of 50 MW and would be able to deliver power bi-directionally between the east and west buses at Talega. The dc-links are physically in place for this future option, which would essentially require only software-based control adjustments for B2B operation.

### **Distribution-STATCOM (D-STATCOM)**

The distribution-STATCOM can operate in an identical manner to the transmission STATCOM. The main difference is that the magnitude of  $V_c$  is not proportional to the capacitor voltage, as would be the case with a fixed pulse pattern, but can be varied by changing the reference of the PWM control. As with a transmission STATCOM, the capacitor acts as an energy store, and its size is chosen based on control and harmonic considerations [15].

An example of how a DSTATCOM provides benefit for both an industrial user and its interconnecting electricity supplier is the Seattle Iron and Metals DSTATCOM project, implemented in early 2000. In this case, Seattle Iron and Metals operates a large, 4000 hp shredder motor, that without voltage compensation can cause significant flicker on the interconnecting 4.16 kV supply network that is further reflected to the utility's (Seattle City Light) 26-kV distribution system. Installing a D-STATCOM including IGBT based inverters, control, and cooling, suppresses the voltage flicker caused by the motor operation and controls voltage within IEEE 519 standards, with the power factor on the 4.16-kV system typically near 1.0. In short, other customers (offices, residences, other plants) are no longer affected by the operation of the large shredder motor. In addition, the D-STATCOM allows greater productivity from the shredder motor, maximizing Seattle Iron and Metals operating efficiency and profits. This same type of productivity improvement has been realized at other steel manufacturing facilities, such as for arc furnace operations [12].

## **B.4 Thyristor Controlled Series Compensator**

### **Principle of operation**

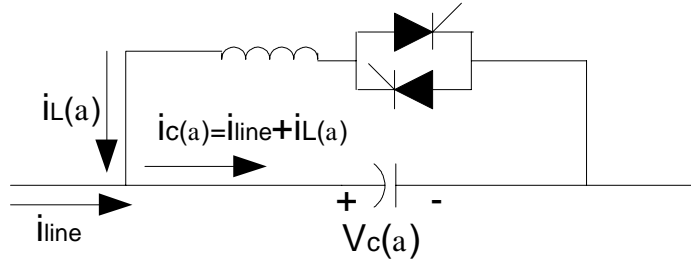
The TCSC can vary the impedance continuously to levels below and up to the line's natural impedance. This helps in increasing the power flow over the line in steady state and also it will respond rapidly to control signals to change the line impedance, thereby damping oscillations during and after a disturbance. In the TCSC scheme, part of the compensation could be fixed and part could be made variable which can be varied during transient conditions [5]. An example circuit is shown in Fig. B.7; TCR current injection circulates through the capacitor- increasing effective  $V_c$ .

The effective impedance is

$$X_{TCSC}(\alpha) = \frac{X_c X_L(\alpha)}{X_L(\alpha) - X_c}$$

$$\text{where } X_L(\alpha) = X_L \left( \frac{\pi}{\pi - 2\alpha - \sin(2\alpha)} \right).$$





**Fig. B.7. Circuit for a TCSC [6].**

Note that  $\alpha$  is the firing delay angle measured from the  $V_c$  peak; we can tune L and C for resonances. It introduces, however, Q lower than synchronous natural frequency, and its use is therefore limited by the possibility of sub-synchronous resonance (SSR) with one of the natural mechanical frequencies of a rotating machine, especially a steam turbo-alternator set.

### Characteristics

Series capacitors installations can also be controlled by thyristors. TCSC offers several advantages over conventional fixed series capacitor installations.

These advantages include

- Continuous control of desired compensation level
- Direct smooth control of power flow within the network
- Improved capacitor bank protection
- Local mitigation of subsynchronous resonance (SSR). This permits higher levels of compensation in networks where interactions with turbine-generator torsional vibrations or with other control or measuring systems are of concern.
- Damping of electromechanical (0.5-2 Hz) power oscillations which often arise between areas in a large interconnected power network. These oscillations are due to the dynamics of inter-area power transfer and often exhibit poor damping when the aggregate power transfer over a corridor is high relative to the transmission strength.

### Summary of TCSC technology installations [1]

TCSC has 10 years of successful operating experience for utility customers. There is continued strong interest for applying TCSC because it is SSR-neutral.

First installations in the United States

- TCSCs by GE (BPA) and Siemes (WAPA)
- TSSC by ABB (AEP)

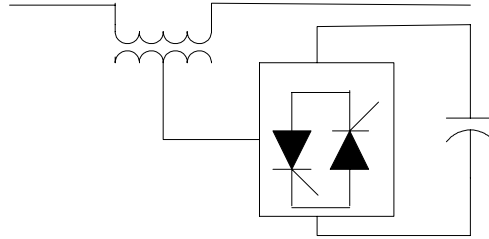
Most recent installations in Brazil

- Four TCSCs in new 500 kV north-south lines

### B.5 Static Synchronous Series Controller (SSSC)

#### Principle of operation

The schematic diagram shown in Fig. B.8 represents an SSSC inserted in the line. An SSSC basically consists of a converter with semiconductor devices having turn-off capability, a coupling transformer, and a capacitor. The converter is connected to a power system through the



**Fig. B.8. Circuit for SSSC.**

coupling transformer. The dc capacitor provides a dc voltage support for the converter operation and functions as an energy storage element; there is no dc source [16].

An SSSC is represented with an ac voltage source whose output voltage has  $90^\circ$  phase lead or lag to the line current. SSSC is able to emulate a line-reactance compensator by injecting ac voltage source whose magnitude and sign can be controlled. Series compensation with SSSC is conceptually similar to that of a capacitor. But its compensation characteristic is slightly different. SSSC can inject a voltage without regard to the line current [17].

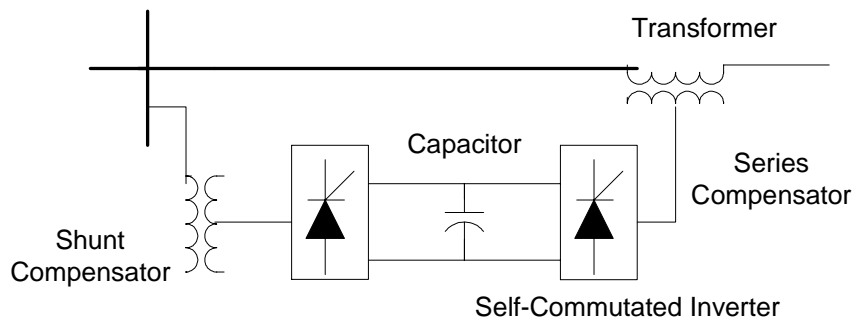
This device effectively alters power system parameters in order to increase power transfer capability, stabilize a system, help resolve energy market caused by congestion problems, and maximize economic value of transmission systems [16].

## B.6 Unified Power Flow Controller

### Principle of operation

The UPFC has been characterized as a “third generation” FACTS device, building on the STATCOM and other units. Basically it involves shunt connecting a STATCOM with a series branch of the transmission line [12].

In the case of a UPFC, an ac voltage vector generated by a thyristor based inverter is injected in series with the phase voltage. The driving dc voltage for the inverter is obtained by rectifying the ac to dc from the same transmission line. In such an arrangement, the injected voltage may have any phase angle relationship to the phase voltage. It is therefore possible to obtain a net phase and amplitude voltage change that confers control of both active and reactive power. A schematic diagram of UPFC is shown in Fig. B.9. The world’s first UPFC has been installed at the AEP Inez station in Kentucky, USA. This  $\pm 320$  MVA UPFC installation in Inez will be completed in 2 phases, the first phase includes a voltage source  $\pm 160$  MVA shunt inverter and the second phase will comprise identical  $\pm 160$  MVA inverters connected in series. Together both inverters will operate as a UPFC. This application will optimize the use of existing facilities, minimize the need for adding new facilities, and demonstrate the application of new solid-state transmission system control technology [5].



**Fig. B.9. Basic circuit for a UPFC [1].**

## Characteristics

The UPFC added the capability to control each of the three basic parameters that determine both the *direction* and *magnitude* of both real and reactive power flow on a transmission line: voltage, impedance and phase angle. It thus performs the same functions as a phase shifting transformer, with the exception that it adds control over phase angle as well. With this capability, the UPFC can switch MW quantities of power on a near-instantaneous basis. By controlling all three parameters, the UPFC allows the operator to direct power flows onto a designated corridor, avoiding unwanted loop flows [12]. Figure B.10 illustrates the control modes of the series compensator part of the UPFC.

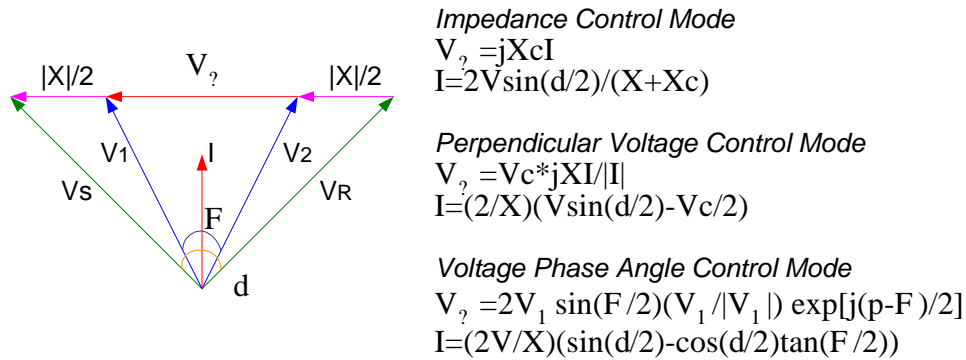


Fig. B.10. Control modes of the series compensator [1].

## Installation project [12]

The UPFC was originally developed under sponsorship of EPRI, Westinghouse (now Siemens Power Transmission and Distribution), and the Western Area Power Administration (WAPA). Several of the major electrical equipment manufacturers now offer them.

The first utility installation of a  $\pm 320$ -MVA UPFC was in 1998 at AEP's Inez, Kentucky substation. The station was serving roughly 2000 MW of power through a heavily loaded set of 138-kV transmission lines. The company was faced with voltage sagging to 95% of nominal voltage, providing very little margin for stability. The installation was to add approximately 100 MW of additional power transfer capacity.

The UPFC concept was proposed as the natural extension of an emerging family of power electronic equipment, capable of inserting controlled synchronous voltage sources (SVS) either in shunt or in series with electric power transmission lines, for the purpose of optimizing power flow in transmission systems. The shunt-connected SVS is referred to as a STATCOM. A series-connected SVS is referred to in general as a static synchronous series compensator (SSSC). The SSSC can insert a synchronous voltage component in series with the line in phase-quadrature with the line current, thereby allowing the power flow on the line to be regulated. Alternatively, either the STATCOM or the SSSC can be provided with a source or sink of real power at their dc terminals such as an energy storage device. Then the STATCOM is also capable of exchanging real power with the local bus, and the SSSC is capable of injecting voltage at any phase angle relative to the line current, so that it can independently regulate the real and reactive power flow.

Phase I of the Inez installation, now completed, included the  $\pm 160$ -MVA STATCOM to provide voltage support and to coordinate the control of area capacitor banks. A 345/138-kV, 600-MVA transformer bank has also been installed at Baker/Big Sandy Station, and series reactors have been installed to constrain loading on thermally limited lines.

Phase II, also complete, included construction of a new 32-mile high-capacity double circuit line between Big Sandy and Inez Stations. This line has an ultimate thermal capability of carrying about 950 MVA. Additional capacitor banks have also been installed at Inez. The Inez UPFC was

completed by the addition of the second inverter connected in series with the new Big Sandy-Inez line. The inverter will function to optimize utilization of the new high capacity line, especially under contingency conditions.

The Inez project cost \$90 million, which included various other enhancements as well as the UPFC installation.

## **B.7 Interline Power Flow Controller [18]**

The interline power flow controller (IPFC), proposed by Gyugyi with Sen and Schauder in 1998, addressed the problem of compensating a number of transmission lines at a given substation. Conventionally, series capacitive compensation, which is fixed thyristor-controlled or SSSC-based, is employed to increase the transmittable real power over a given line and also to balance the loading of a normally encountered multi-line transmission system. However, independent of their means of implementation, series reactive compensators are unable to control the reactive power flow in, and thus the proper load balancing of, the lines. This problem becomes particularly evident in those cases where the ratio of reactive to resistive line impedance,  $X/R$ , is relatively low. Series reactive compensation reduces only the effective reactive impedance  $X$ , which significantly decreases the effective  $X/R$  ratio and thereby increases the reactive power flow and losses in the line. The IPFC scheme, together with independently controllable reactive series compensation of each individual line, provides a capability to directly transfer real power between the compensated lines. This capability makes it possible to:

- Equalize both real and reactive power flow between the lines;
- Reduce the burden of overloaded lines by real power transfer;
- Compensate against resistive line voltage drops and the corresponding reactive power demand;
- Increase the effectiveness of the overall compensating system for dynamic disturbances.

In other words, the IPFC can potentially provide a highly effective scheme for power transmission management at a multi-line substation.

In its general form the IPFC employs a number of dc-to-ac converters providing series compensation for a different line. In other words, the IPFC comprises a number of SSSCs. However, within the general concept of the IPFC, the compensating converters are linked together at their dc terminals, as illustrated in Fig. B.11. With this scheme, in addition to providing series reactive compensation, any converter can be controlled to supply real power to the common dc link from its own transmission line. Thus, an overall surplus power can be made available from the under utilized lines which then can be used by other lines for real power compensation. In this way, some of the converters, which are compensating overloaded lines or lines with a heavy burden of reactive power flow, can be equipped with full two-dimensional, reactive and real power control capability, similar to that offered by the UPFC.

## **B.8 Phase Angle Regulator**

Another way to control the power flow on the transmission line is through phase angle regulator. The phase shift is accomplished by adding or subtracting a variable voltage component that is perpendicular to the phase voltage of the line. This perpendicular voltage component is obtained from a transformer connected between the other two phases. In the scheme shown in Figure B.12, the three secondary windings have voltages proportional to 1:3:9. Thyristor switches, one per winding, allow each winding to be included or excluded in the positive or negative direction. The choice of 1, 3, 9—along with the plus or minus polarity for each

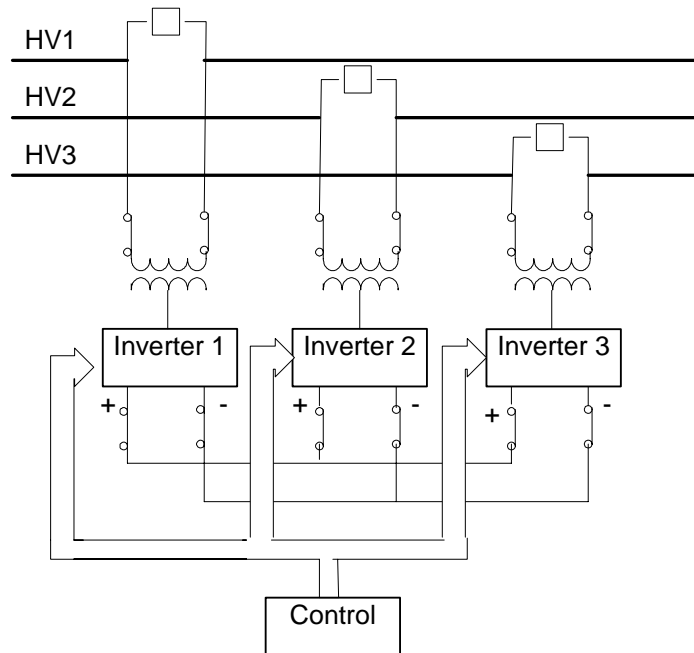
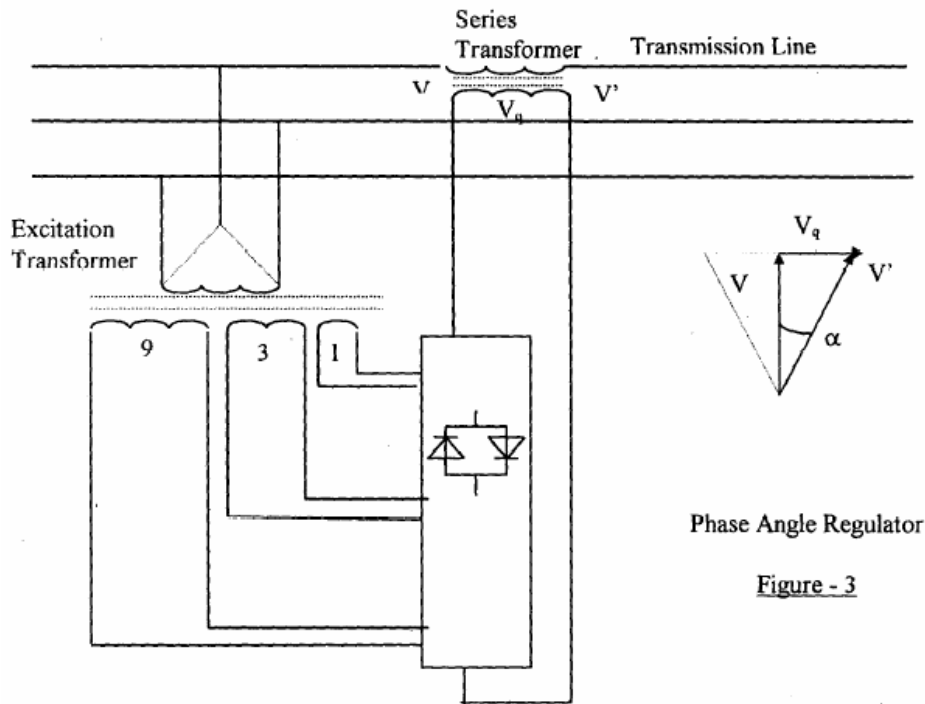


Fig. B.11. Interline power flow controller comprising three converters [18].



Phase Angle Regulator

Figure - 3

Fig. B.12. Phase angle regulator [5].

winding—yields a switchable voltage range of -13 to +13, thus giving a variable high speed control of the perpendicular voltage component. The voltage corresponding to each unit step will of course determine the total phase shift that results [5].

## B.9 Convertible Static Compensator (CSC)

The CSC is an innovative concept that offers multiple compensation functions for power transmission systems. The CSC may be operated in different configurations. Depending on the configuration, the CSC is capable of simultaneously controlling voltage at an ac bus and changing real and reactive power flow in two ac transmission lines. What is unique about the CSC is that it can be used to transfer power back and forth between two lines, enabling the operator to maximize capacity utilization. The installation and application of the CSC is a major advancement in the commercialization of FACTS controllers [19].

The first CSC installation is being used by the New York Power Authority at its Marcy substation near Utica in order to enhance control and expand transmission capacity at a bottleneck on the heavily congested Utica-Albany lines. The 200 MVA 345 kV CSC consists of two voltage-sourced converters connected to the Marcy bus through the 200 MVA shunt transformer or two 100 MVA series coupling transformers as shown in Fig. B.13. The CSC, through appropriate arrangement of disconnect switches and circuit-switchers, can have 11 configurations. The CSC can function as a STATCOM, SSSC, UPFC or IPFC, as listed in Table B.5. The changes between different configurations are achieved through appropriate switching of circuit breakers, disconnect switches and the dc switch connecting the dc buses of the two converters. The SSSC can be placed either on Marcy – New Scotland or Marcy–Coopers Corners line. If the dc switch is closed the corresponding UPFC and IPFC configurations allow real power transfers from Converter 1 to Converter 2 and vice versa. In general, any configurations can be obtained at any time, which gives the CSC great operational flexibility.

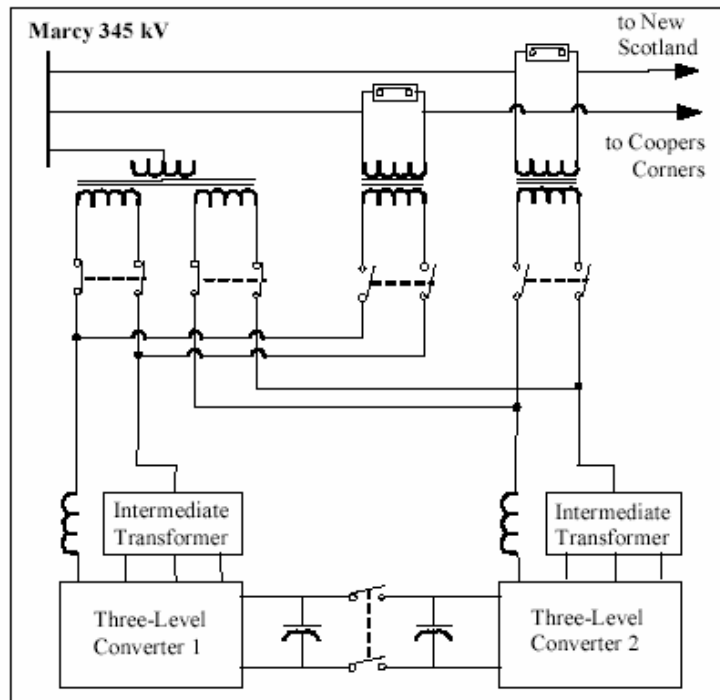


Fig. B.13. Simplified schematic of the convertible static compensator [20].

**Table B.5. CSC configurations and MVA ratings**

	Configuration	MVA Rating
1	STATCOM	100 or 200
2	SSSC	100 or 200
3	STATCOM & SSSC	100 & 100
4	UPFC	200
5	IPFC	200

The CSC installation was completed in two phases. The shunt portion of the CSC, the 345 kV+/- 200 MVar STATCOM was installed and operating by February 2001. The STATCOM regulates voltage at the Marcy substation. In addition, a 135 MVar capacitor bank has been installed at Oakdale [19]. It has expanded transmission capacity on the Utica-Albany line by about 60 MW and on the total system by nearly twice as much [12].

During the second phase, which was completed in October 2003, two series transformers were connected in the Marcy-New Scotland and Marcy-Coopers Corner 345 kV transmission lines. This allowed other controller configurations, namely SSSC, UPFC, and IPFC to be commissioned. A 200-MVar capacitor bank was also installed at Edic substation during the second phase. Now that the second phase of the project is complete, the CSC has the capability to regulate bus voltage and control real and reactive power flows on the Marcy to New Scotland and Marcy to Coopers Corner 345-kV transmission lines [19]. The installation is expected to increase the transfer capacity by about 120 MW on the directly-congested path and 240 MW for the total system [12].

What does it cost? The Marcy installation is expected to cost about \$48 million for an increase in capacity of 120 MW on the directly congested path and 240 MW for the system as a whole (or about \$200/kW for the total system capacity expansion). The project is being funded by a consortium of several dozen utilities, with Siemens doing the construction [12]. Table B.6 shows us the CSC general specifications summary.

## **B.10 Reactive Power Compensation Sources**

### **Dynamic Var [7]**

Dynamic Var (D-var) voltage regulation systems dynamically regulate voltage levels on power transmission grids and in industrial facilities; D-var is a type of STATCOM. D-var dynamic voltage regulation systems detect and instantaneously compensate for voltage disturbances by injecting leading or lagging reactive power to the part of the grid to which the D-var is connected. The amount of reactive power delivered per unit varies typically from 1 MVar to 8 MVar continuously, with near-instantaneous reactive power output of up to 24 MVar. There are currently 22 installations of D-var systems in North America.

D-var voltage regulation systems are scalable and mobile, characteristics that allow utilities to install them in their power grid at locations that need the greatest amount of reactive power support. D-var dynamic voltage regulation system components can be configured inside a standard truck trailer that can be moved to substations for optimized var support throughout a power grid or placed in a standard enclosure for more permanent siting at a substation. D-var systems provide dynamic var support for transmission grids that experience voltage sags, which are typically caused by high concentrations of inductive loads, usually in industrial manufacturing centers, or from weaker portions of the transmission grid, typically in remote areas or at the end of radial transmission lines.

D-var systems also are suited to address the need for dynamic var support at wind farms. Because of the remote locations of most large wind farms, the power they generate must often be delivered a long distance to the ultimate customer on a relatively weak utility transmission grid.

**Table B.6. CSC general specifications summary [19]**

Nominal CSC System Rating	(±) 200 MVar of shunt compensation or 2× 11 kV of series injected voltage [(±) 100 MVA] or (±)100 MVar of shunt compensation and 11 kV of Series injected voltage.
Nominal System Voltage	345 kV
Main CSC Function	Control electrical power flow on transmission lines and/or dynamic voltage regulation of the Marcy Substation bus
Basic CSC System Arrangement	Two (±) 100 MVA inverters connected to a 345 kV bus via a shunt coupling transformer with dual secondaries, Or two (±) 100 MVA inverters connected in series with two 345 kV transmission lines via two series insertion transformers, Or one (±) 100 MVA inverter connected to a 345 kV bus via a shunt coupling transformer, and one (±) 100 MVA inverter connected in series with a 345 kV transmission line via a series insertion transformer.
Inverter Nominal Rating	Two inverters, each one (±) 100 MVA continuously variable
Inverter Nominal dc Voltage	+/- 6,014 Volts dc (12,028 Vdc positive to negative)
Inverter Max. Continuous dc Voltage	+/- 7,147 Volts dc (14,293 Vdc positive to negative)
Inverter Nominal Pole Current	1,556 Amps ac rms (2,200 amps peak)
Inverter Nominal Pole Voltage	5,357 Volts ac rms (line to neutral)
Number of Inverter Poles	24 Poles (12 per inverter)
Number of GTO's per pole	24 GTO's (12 aeries GTO's per positive & negative side)
Inverter Configuration	3 level voltage source inverter, 48 Pulse
Dc Capacitor Bank Arrangement per Inverter	Eight aapacitor banks of 2,820 µF. Each bank with 10 parallel cans. Total number of cans = 80 Total effective capacitance = 1,410 µF
Dc Capacitor Can Rating	5.4 kV dc per can, 282 µF per can

A D-var system is ideally suited to mitigating voltage irregularities at the point of interconnection between the wind farm and the grid. D-var systems can be integrated with low cost capacitor banks to provide an extremely cost effective solution for large wind farms. For instance, a small 8 MVA D-var device combined with a number of medium voltage capacitor banks is sufficient to solve most of the voltage problems associated with wind farms.

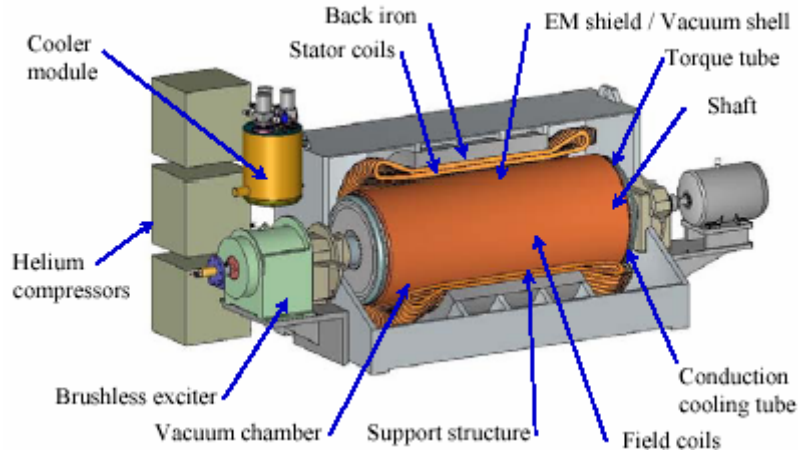
## SuperVAR [21]

American Superconductor's (AMSC) SuperVAR machines, shown in Figure B.14, are rotating machines much like motors and generators utilize high-temperature superconductor (HTS) technology, and serve as reactive power "shock absorbers" for the grid by dynamically generating or absorbing reactive power (VARs), depending on the voltage level of the transmission system.

AMSC's SuperVAR machines use standard synchronous condenser frames and stator coils mated with new, power-dense rotor coils made from AMSC's HTS wire, which is the world's first commercial product based on HTS technology. The result is a synchronous condenser that is more efficient than conventional machines without the typically high rotor maintenance costs. The SuperVAR has the following benefits:

- Transient dynamic voltage support and stability (leading and lagging VARs) at a multiple of the machines rating
- Economic transmission voltage support and stability improvement
- Increased transmission capacity by reducing transmission losses
- Power factor correction during steady state operation
- Stable operation up to its rated load in either leading or lagging mode
- Minimum operating power consumption





**Fig. B.14. American Superconductor's SuperVAR dynamic synchronous condenser [22].**

- Minimum harmonic content
- Less maintenance on machine rotor windings
- Modular transportable design
- Easy installation

Specifications are as follows:

Continuous rating	$\pm 12$ MVAR
Overload rating	2 pu for 60 sec; 3 pu for 15 sec
Voltage rating	13.8 kV line to line
Losses	Less than 1.8% of rating
Communication	Remote monitoring and control of VARs
Auxiliary power	480V, 3-phase, 75 kW
Dimensions	Typically 8 ft $\times$ 10 ft $\times$ 24 ft

The Tennessee Valley Authority ordered first five production units and installed them on a power grid in Gallatin, Tennessee, U.S., in January 2004. By reducing voltage “flicker” on the transmission system, future brownouts and blackouts can be prevented. And the SuperVAR machine is expected to use 50-percent less energy than conventional voltage-stabilizer technologies, helping reduce the overall cost of delivering power [23].

### **Distributed SMES (D-SMES)**

A superconducting magnetic energy storage (SMES) system is a device for storing and instantaneously discharging large quantities of power. These systems have been in use for several years to solve voltage stability and power quality problems for large industrial customers. A distributed-SMES (D-SMES) system is a new application of proven SMES technology that enables utilities to improve system reliability and transfer capacity.

D-SMES is a shunt-connected FACTS device designed to increase grid stability, improve power transfer and increase reliability. Unlike other FACTS devices, D-SMES injects real power as well as dynamic reactive power to more quickly compensate for disturbances on the utility grid. Fast response time prevents motor stalling, the principal cause of voltage collapse. D-SMES devices can be transported on standard truck trailers, with one 250-kW system per trailer. The inverters provide up to 2.3 times nominal instantaneous over-current capability and can also be

configured for continuous var support. Each 250-kW trailer operates independently, improving reliability. Six D-SMES systems are installed in the midwestern United States [7].

The SuperVAR machine is a new product that complements AMSC's family of reactive power grid stabilization solutions, which include AMSC's D-VAR systems and D-SMES systems. SuperVAR synchronous condensers are specifically designed for continuous, steady state dynamic VAR support and they maintain a reserve for transient problems. D-VAR systems—which are based on AMSC's PowerModule power electronic converters—are designed to solve local voltage issues through a controlled, directed output thus addressing more specific existing or known transient problems. D-SMES systems provide real and reactive power in industrial and grid settings by integrating a superconducting magnet with the advanced power electronics found in D-VAR systems [21].

### B.11 Layout of a Typical HVDC Converter Station [24]

The layout of a typical HVDC converter station for 500–600 MW is shown in Figure B.15. Essentially, the voltage source converter back-to-back (VSC-B2B) system is the B2B configuration of STATCOM units, with a common dc source acting as the dc link to the system. This configuration allows for the control of real power flow across the tie as well as independent dynamic reactive power compensation and continuous voltage control on both sides of the link. This means that the installation is an alternative to conventional HVDC valve systems for linking two networks. Utilizing VSC-based technology also leads to more compact designs and significant space savings compared to classic dc technology. With the ability to parallel multiple terminals on either side of the link, VSC-B2B provides both application flexibility and future expansion capability for large amounts of dc-tie control across ac networks.

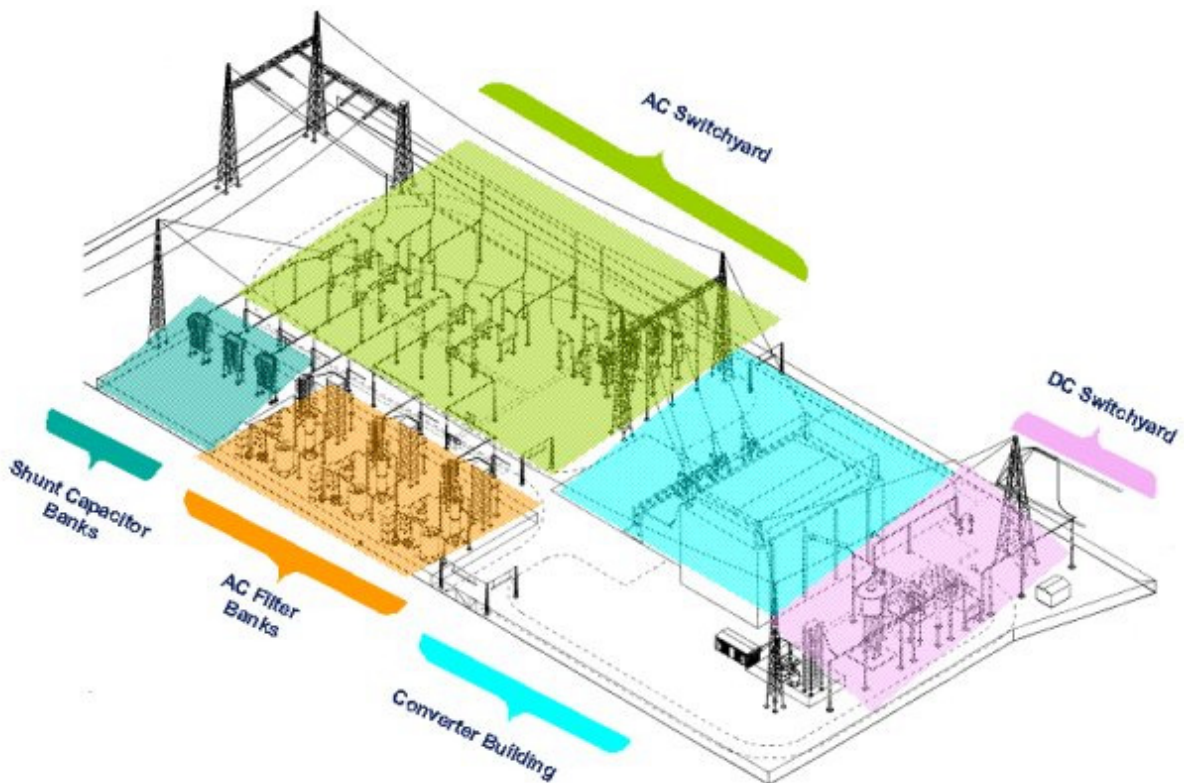


Fig. B.15. Layout of a typical HVDC converter station [24].

In short, this B2B configuration to create a dc link represents an important potential FACTS configuration for HVDC-type operation, but with superior performance and control advantages as compared to conventional HVDC technology.

Deploying VSC units in the B2B configuration offers another approach for interconnecting large network areas that are asynchronous, have weak short-circuit capacity, or are limited by some other system constraint. This would allow for “seamless” interconnection of proposed regional transmission organization (RTO) areas, more dynamic control for future East-West ties, as well as ties to Canada and Mexico, and can also provide inter-tie reliability improvements and power flow control.

In 1998, Tokyo Electric Power Company installed this VSC-B2B at its Shin-Shinano Substation. The project was part of an overall national power system development program, which included participation by Mitsubishi Electric for the VSC hardware and control of the multi-terminal design. Although a number of projects of this type have been proposed in the U.S., and hardware configurations have been implemented that are expected to be fully operational in the near future, there are as yet no VSC-B2B systems in operation in the U.S.

## **B.12 Companies Developing FACTS and HVDC-Related Products**

The following section lists companies that are developing FACTS and HVDC related products. Most of these companies have a global presence and have equipment installed throughout the world.

### **Mitsubishi Electric Power Products, Inc.**

Thorn Hill Industrial Park  
512 Keystone Drive  
Warrendale, PA 15086  
Phone: (724) 772-2555  
Facsimile: (724) 772-2146  
<http://www.meppi.com/index.html>

Mitsubishi Electric Power Products, Inc. (MEPPI) serves the North American power systems, metals production, rail transportation, and water treatment industries with electrical and electronic products, systems and services. In addition, MEPPI’s US manufactured gas circuit breakers are exported around the world.

Headquartered in Warrendale, PA, MEPPI is a subsidiary of Mitsubishi Electric Corporation of Japan, and one of the Mitsubishi Electric and Electronics USA (MEUS) group of companies. The Power Electronics and Engineering Analysis area provides advanced, high-performance voltage sourced converter (VSC) based and conventional thyristor-based technologies for power delivery solutions, including FACTS, such as transmission level SVCs and static reactive compensation (STATCOM) and unified power flow control (UPFC); HVDC transmission systems and VSC-based B2B dc link systems; and custom power equipment for utility and industrial power quality applications. Utilizing advanced industry standard modeling and simulation, Mitsubishi can conduct a wide range of analytical investigations for both utility and industrial applications.

Selected Recent Installations  
HVDC (LTT-based dc-link and B2B Systems)  
Kii Channel (June-2000)  
Minami-Fukumitsu (March 1999)  
Uruguaiana (1994)  
Sakuma (1993)

Shin-Shinano II (1992)  
FACTS , SVC (LTT-Based Transmission Applications)  
Lismore (December 1999)  
Ross (October 1998)  
FACTS , SVC (Wind Farm Application)  
Starfish Hill (August 2003)  
FACTS , STATCOM and B2B (VSC-Based Transmission Applications)  
San Diego Gas & Electric—Talega (February 2003)  
Vermont ElectricEssex (May 2001)  
Shin-Shinano (January 1999)

## **ABB**

ABB Inc.,  
U.S. Headquarters  
501 Merritt 7  
P.O. Box 5308  
Norwalk, CT 06851  
Phone: (203) 750-2200  
Fax: (203) 750-2263  
<http://www.abb.us/>

The ABB Group of companies operates in around 100 countries and employs around 102,000 people. In the United States, ABB employs nearly 8,500 in 32 states. The U.S. headquarters is based in Norwalk, Connecticut. ABB is a leader in the field of FACTS. ABB has the full FACTS portfolio and in-house manufacturing of key components.

The HVDC technology is used to transmit electricity over long distances by overhead transmission lines or submarine cables, and to interconnect separate power systems, where traditional ac connections cannot be used. HVDC Light<sup>®</sup> is a new power transmission technology developed by ABB. It is particularly suitable for medium to small-scale power transmission applications.

Electrical loads both generate and absorb reactive power. Since the transmitted load varies considerably from one hour to another, the reactive power balance in a grid varies as well. The result can be unacceptable voltage amplitude variations, a voltage depression, or even a voltage collapse. A rapidly operating Static Var Compensator (SVC) can continuously provide the reactive power required to control dynamic voltage swings under various system conditions and thereby improve the power system transmission and distribution performance. Installing an SVC at one or more suitable points in the network can increase transfer capability and reduce losses, while maintaining a smooth voltage profile under different network conditions. In addition, an SVC can mitigate active power oscillations through voltage amplitude modulation.

## **Toshiba America, Inc. (TAI)**

Toshiba America, Inc.  
1251 Avenue of the Americas  
Suite 4110  
New York, NY 10020  
<http://www.toshiba.com/tai-new/index.jsp>

Transmission & Distribution Product Summary:  
[http://www.tic.toshiba.com.au/website/newtic/pd\\_pdcttd.htm](http://www.tic.toshiba.com.au/website/newtic/pd_pdcttd.htm)  
HVDC

[http://www.tic.toshiba.com.au/website/newtic/hvdc\\_fc.htm](http://www.tic.toshiba.com.au/website/newtic/hvdc_fc.htm)

#### FACTS

<http://www.toshiba.co.jp/f-ene/hydro/english/products/facts/index.htm>

#### SVC

[http://www.tic.toshiba.com.au/website/newtic/svc\\_ltt.htm](http://www.tic.toshiba.com.au/website/newtic/svc_ltt.htm)

The Toshiba America Group specializes in advanced electronics and in products that enhance the home, office, industry and health care environments. Toshiba markets and manufactures information and communication systems, electronic components, heavy electrical apparatus, consumer products and medical diagnostic imaging equipment.

Toshiba power electronics technologies extend to FACTS applications. In addition to line-commutated converter technology using a light triggered thyristors, Toshiba develops advanced self-commutated converters using GTO (gate turn-off) thyristors.

### **ALSTOM**

#### Quarters K

1123 Admiral Peary Way

Philadelphia, PA 19112

Phone: +1 215 989 2090

Fax: +1 215 989 2070

<http://www.powerconv.alstom.com/home/>

<http://www.sovereign-publications.com/alstom.htm>

ALSTOM is organized in six sectors, Energy, Transmission & Distribution, Transport, Industry, Marine and Contracting, all of these being supported by the ALSTOM Network. Since July 1999, ALSTOM operates in Energy through ABB ALSTOM POWER, the 50-50 joint company created with ABB. Present in more than 60 countries, ALSTOM now directly employs 92,000 people, with a further 58,000 people employed by ABB ALSTOM POWER.

ALSTOM SVC systems employ advanced high-power thyristors and digital control technology to compensate for voltage fluctuations, and to supply leading or lagging vars in less than half a power frequency cycle-more than 120 times per second

[http://www.powerconv.alstom.com/home/products/powerquality/voltage\\_stability/26.EN.php?languageId=EN&dir=/home/products/powerquality/voltage\\_stability/](http://www.powerconv.alstom.com/home/products/powerquality/voltage_stability/26.EN.php?languageId=EN&dir=/home/products/powerquality/voltage_stability/)

Leading the transmission business is Power Electronics, the use of high voltage electronic devices for the control of power systems. Within the T&D systems business of ALSTOM, ALSTOM T&D Power Electronic Systems Limited (PES), the center for HVDC converters and other power electronic systems, has its base in Stafford, UK. It employs some 275 people and has an annual turnover of around US\$50 million. The company manages comprehensive electrical projects, involving specialized power electronic equipment, together with many sophisticated control and monitoring facilities, from early feasibility study stages through design and manufacture, to installation (including civil work), site testing and after sales service.

These projects include:

- Converter stations for HVDC transmission, providing interconnections between systems, submarine or overland or back to back
- Power electronic controllers for FACTS
- SVCs of all types, for the fast support of power system voltage everywhere

The Power Conversion sector of ALSTOM offers a range of solutions to improve power quality and enhance productivity through the design and construction of static var compensators (SVC) for industrial plants. With more than 25 years of SVC experience ALSTOM has installed over 100 currently operating systems worldwide, and more than 6,000 megavars.

## **Siemens USA**

Siemens Corporation  
Citicorp Center  
153 East 53rd Street  
New York, NY 10022-4611  
General Info. & Directory  
Tel.: 1-800-SIEMENS  
E-mail: [usa.800siemens@siemens.com](mailto:usa.800siemens@siemens.com)  
<http://www.usa.siemens.com/index.jsp>

Siemens is a \$91 billion electronics company with 430,000 employees in 192 countries. With 70,000 employees and \$16.6 billion in U.S. sales, Siemens is improving America's infrastructure through technology and innovation in Medical, Power, Automation and Control, Transportation, Information and Communications, Lighting, Building Technologies, Water Technologies and Services and Home Appliances.

Siemens Power Transmission & Distribution, Inc., Power Technologies International (Siemens PTI) is a consulting engineering company and a leader in electrical power systems analysis for generation, transmission, distribution and industrial plants. <http://www.pti-us.com/>

Siemens has been in HVDC technology for more than 25 years. Siemens Power Transmission & Distribution, Inc., headquartered in Raleigh, NC, creates equipment and energy service solutions for electric utilities, independent power producers, co-generators and other energy-intensive industries. Its products and systems are used to increase power system capacity and improve the reliability, stability and flexibility of power delivery systems. It has operations in Wendell, NC; Jackson, MS, Minneapolis, MN; San Jose, CA; and Atlanta, GA. For more information visit, <http://www.ptd.siemens.com>.

Siemens Power Transmission & Distribution, Inc., an affiliate of Siemens AG, has announced that they and their partner, Beta Engineering, have begun construction under a contract from Public Service Company of Colorado (PSCO), Denver, CO, for an HVDC B2B converter.

## **General Electric Company**

GE Energy  
4200 Wildwood Parkway  
Atlanta, GA 30339  
<http://www.gepower.com/home/index.htm>

### **HVDC**

[http://www.gepower.com/prod\\_serv/serv/energy\\_consulting/en/equip\\_app/hvdc\\_trans.htm](http://www.gepower.com/prod_serv/serv/energy_consulting/en/equip_app/hvdc_trans.htm)

### **FACTS**

[http://www.gepower.com/prod\\_serv/serv/energy\\_consulting/en/equip\\_app/facts\\_app.htm](http://www.gepower.com/prod_serv/serv/energy_consulting/en/equip_app/facts_app.htm)

GE is known for advanced power systems and around-the-clock energy services. Since GE installed its first steam turbine in 1901, its installed base of steam and heavy duty gas turbines has grown to over 10,000 units, representing over a million MW of installed capacity in more than 120 countries. GE Energy electrifies the world by providing reliable, efficient products and

services for the energy industry. GE works in all areas of the energy industry including coal, oil, natural gas and nuclear energy, as well as with renewable resources such as water and wind energy.

GE provides a wide range of consulting services of value to the operator or owner of a power system to which a merchant HVDC system may be attached. These services include:

- HVDC system interconnection specifications
- Feasibility studies
- System and commercial impact studies
- Functional interconnection requirement studies
- Interconnection technical proposal evaluation
- Merchant design study compliance review
- HVDC technology seminars
- Evaluation of post-commissioning performance

The most common FACTS devices include the TCSC, SVCs, thyristor controlled phase-angle regulator (TCPAR), static condenser (STATCON), and BESS. These devices provide dynamic var compensation to the system.

Depending on the device, these FACTS devices provide the following benefits to the system: increased power transfer capability, mitigation of subsynchronous resonance (SSR), rapid voltage control, improved power quality, power system damping, and improved system stability.

GE has advanced analytical tools to simulate all these FACTS devices in both the frequency and time domain. These studies enable GE to develop the functional requirements for control and power system equipment.

### **Hitachi America, Ltd.**

Hitachi America, Ltd., Power & Industrial Division  
50 Prospect Avenue  
Tarrytown, NY 10591-4698  
Tel: (914) 631-0600  
Fax: (914) 332-5388  
<<http://www.hitachi.us>>  
<<http://www.hitachi.us/power>>  
<<http://www.hitachi-rail.com>>

HVDC: <http://www.hitachi.us/Apps/hitachicom/content.jsp?page=powerequipment/PowerTransmissionDistribution/Transformers/index.html&level=2&section=powerequipment&parent=PowerTransmissionDistribution&nav=left&path=jsp/hitachi/forbus/powerequipmentsystems/>

HVDC Transformer

Hitachi has developed high voltage, large capacity transformers for use in HVDC systems.

### **AREVA**

4800 Hampden Ln  
Suite 1100  
Bethesda, MD (USA) 20814  
Phone: 301.652.9197 Fax: 301.652.5691  
[www.areva.com](http://www.areva.com)

[http://www.aveva-td.com/static/html/TDE-AGF\\_ProductLine-ProductLine\\_Detailv2\\_1026742850149.html?](http://www.aveva-td.com/static/html/TDE-AGF_ProductLine-ProductLine_Detailv2_1026742850149.html?)

The AREVA T&D division supplies products, systems and services for electricity transmission and distribution. They are used to regulate, switch, transform and dispatch electric current in electric power networks connecting the power plant to the final user.

AREVA T&D products and solutions play an essential role in electricity network reliability, quality and safety. The division's customers are electric utilities as well as the oil, mining and metals, wind energy, paper and glass, transportation, and power engineering industries. AREVA T&D provides distribution SVCs and industrial SVCs for all needs in power quality control.

## **VA TECH ELIN**

VA TECH ELIN Transformatoren GmbH & Co  
Elingasse 3, 8160 Weiz, Austria, Europe  
Phone: +43 3172 606-0  
Fax: +43 3172 606-488  
E-Mail: [office@vatechetg.at](mailto:office@vatechetg.at)  
<http://www.vatechetg.at/>

Va Tech Elin is an independent Austrian company operating in the fields of engineering, design and manufacturing of transformers for the transmission and distribution of electric energy.

HVDC special transformers: <http://www.vatechetg.at/products/special.asp?LNG=EN>  
Single and three phase  
Short circuit test transformers  
HVDC converter transformers

The main application of HVDC-converter transformers is transfer of electric power via transmission lines by coupling/linking to non synchronized networks. The transformers will be used for service in the converter stations.

Short circuit test transformers are used in test laboratories for breaking short-circuits and load currents on switches and breakers and short-time withstand tests on LV and HV devices.

## **Cooper Power**

U.S. Customer Service Center  
Phone: 262.524.3300 Fax: 262.524.3319  
Cooper Power Systems, Customer Support Center  
1319 Lincoln Avenue  
Waukesha, WI 53186  
<http://www.cooperpower.com/Products/Power/>

The Power Capacitor Products plant located in Greenwood, South Carolina, manufactures McGraw-Edison high voltage power capacitors for worldwide utility and industrial applications for system voltages from 2.4 kV through Extra High Voltage. Cooper Power Systems produces capacitor subsystems for shunt, series, HVDC, SVC, and filtering applications throughout the world.

The Type EX-7L capacitor, introduced by Cooper Power Systems in 1990, and the Type EX-D capacitor, introduced by Cooper Power Systems in 1995, are some of the most technologically advanced capacitors available today.



## B.13 References

1. J. J. Paserba, "How FACTS Benefits ac Power Systems," Panel Session on FACTS Fundamentals, *Proceedings of the IEEE PES 2004 General Meeting*, Denver, CO, June 2004.
2. J. J. Grainger and W.D. Stevenson, *Power System Analysis*, McGraw-Hill, January 1, 1994.
3. P.M. Anderson and A.A. Fouad, *Power System Control and Stability*, Wiley-IEEE Press, October 4, 2002.
4. K. Habur and D. O'Leary, "FACTS: For Cost Effective and Reliable Transmission of Electrical Energy," Siemens.
5. T. Adhikari, "Application of Power Electronics in the Transmission of Electrical Energy," *Proceedings of TENCON '98: 1998 IEEE Region 10 International Conference on Global Connectivity in Energy, Computer, Communication and Control*, Vol. 2, Dec. 17–19, 1998, pp. 522–530.
6. D. Woodford, "How FACTS Controllers Function in an ac Transmission System," *IEEE Power Engineering Society Panel Session – FACTS Fundamentals*, Denver, CO, June 8, 2004.
7. *Principles for Efficient and Reliable Reactive Power Supply and Consumption*, Federal Energy Regulatory Commission, Staff Report, February 4, 2005.
8. [www.abb.com/FACTS](http://www.abb.com/FACTS).
9. [https://conductor.concertsw.com/concert/servlet/sbs.concert.LoadBlob;jsessionid=?wert=67475&mime=application/pdf&doc=SVC\\_References\\_031124.pdf&lang\\_id=1&cmd=1&tab=EV\\_DOC&col=C\\_DOC\\_ID&blob=DOC\\_DATA&voll=J](https://conductor.concertsw.com/concert/servlet/sbs.concert.LoadBlob;jsessionid=?wert=67475&mime=application/pdf&doc=SVC_References_031124.pdf&lang_id=1&cmd=1&tab=EV_DOC&col=C_DOC_ID&blob=DOC_DATA&voll=J).
10. R. Grünbaum, B. Halvarsson, A. Wilk-Wilczynski, "Facts and HVDC Light for Power System Interconnections," Power Delivery Conference, Madrid, Spain, September 1999.
11. M. H. Baker and R. J. Trow, "New FACTS Controllers and How to Assess Them," *Proceedings of the 4th International Conference on Advances in Power System Control, Operation and Management*, APSCOM-97, Hong Kong, November 1997.
12. P. M. Marston, *Of Chips, HiTS, Bits and Bytes: Building the Powerline Paradigm*, A Report and Recommendations of The Grid Enhancement Forum from the Center for the Advancement of Energy Markets, 2002.
13. [http://www.meppi.com/mepssd/NPDF3/STATCOM\\_VELCO.pdf](http://www.meppi.com/mepssd/NPDF3/STATCOM_VELCO.pdf)
14. [http://www.meppi.com/mepssd/NPDF3/STATCOM\\_Talega.pdf](http://www.meppi.com/mepssd/NPDF3/STATCOM_Talega.pdf)
15. Y. Song and A.T. Johns, *Flexible ac Transmission Systems*, IEE Power and Energy Series 30, 1999.
16. M.I. Alomoush, "Static Synchronous Series Compensator to Help Energy Markets Resolve Congestion-Caused Problems," Power Engineering, 2004. LESCOPE-04. *Proceedings of the 2004 Large Engineering Systems Conference*, July 28–30, 2004, pp. 25–29.
17. B. Han, S. Moon, J. Park, and G. Karady, "Dynamic Characteristic Analysis of Multi-bridge PWM Inverter for SSSC," *Proceedings of IEEE Power Engineering Society Summer Meeting, 2000*. Vol. 3, July 16–20, 2000, pp.1618–1623.
18. N.G. Hingorani and L. Gyugyi, *Understanding FACTS: Concepts and Technology of Flexible ac Transmission Systems*, IEEE Press, 2000.
19. *Convertible Static Compensator (CSC) for New York Power Authority: Final Report*, EPRI, Palo Alto, CA, and New York Power Authority, White Plains, NY, 2003.
20. E. Uzunovic, B. Fardanesh, B. Shperling, S. Zelingher, "NYPA Convertible Static Compensator (CSC) Application Phase I: STATCOM," T&D Conference, Atlanta, GA, October 2001.
21. <http://www.amsuper.com/products/motorsGenerators/quickVAR.cfm>.
22. J. B. Howe, "How Can We Build Tomorrow's Grid Within Today's Footprint," presented at NECA's Avoiding Futureshock Conference, December 8, 2004, Boston, MA, 2004.
23. [http://www.tva.gov/retireeportal/retiree\\_news/insidetva/december03/supervar.htm](http://www.tva.gov/retireeportal/retiree_news/insidetva/december03/supervar.htm).

24. [www.abb.com/hvdc](http://www.abb.com/hvdc).

## Appendix C. SILICON POWER SEMICONDUCTOR DEVICES

### C.1 Summary of Silicon Power Semiconductor Device Capabilities

**PN (or PiN) Diodes.** These devices permit current flow in only one direction. They turn ON with a forward bias, and turn OFF with a reverse bias when forward current crosses zero. They are used in almost all power converters. Maximum ratings of these diodes are 10 kV, 10 kA, and 20 kHz.

- Advantage: High voltage and current ratings.
- Disadvantage: High reverse-recovery losses.

**Schottky Diodes.** These devices have faster reverse recovery speeds than the PiN diodes. For applications with voltages above 300 V, they are not as efficient; therefore, Schottky diodes are used in low-voltage applications. Maximum ratings are 600 V, 150 A, and 100 kHz.

- Advantage: Fast switching speeds and low reverse-recovery losses.
- Disadvantage: Low voltage and current rating

**Bipolar Junction Transistor (BJT).** Designed in the 1950s, BJTs will conduct in the forward direction upon command of a control signal, and will stop conducting when the control signal ceases. The control signal is a large current (0.2–0.5 of forward current) supplied to the base. They can be used in rectifiers, dc-dc converters, and dc-ac inverters; however, presently they are not being used in power converters because better power devices are available. Maximum ratings are 1500 V, 200 A, and a few kHz.

- Advantage: Medium voltage and current ratings, controllable turn ON/OFF, and low on-state losses.
- Disadvantage: Slow switching speeds, high switching losses, and current controlled.

**Thyristors (also known as silicon controlled rectifiers or SCRs).** Thyristors, designed in the late 1950s, conduct in the forward direction upon command of a control signal and a forward bias and continues to conduct until both the current ceases and a negative voltage (reverse biased) is applied across the device. A small current is applied to the gate for turn ON operation. Commutation circuits can be used to turn OFF SCRs, which increase the device count and complexity while decreasing the efficiency and increasing the losses. SCRs are used in high power converters. Maximum ratings are 10 kV, 10 kA, and a few kHz.

- Advantage: Large voltage and current ratings, low on-state losses, controllable turn ON, with a small amount of current.
- Disadvantage: Slow switching speeds and uncontrollable turn OFF.

**Metal-Oxide Semiconductor Field Effect Transistor (MOSFETs).** MOSFETs, designed in the 1960s, will conduct in the forward direction upon command of a control signal, and continue to conduct until another command is given. They have the ability to turn ON/OFF no matter what the given voltage and current conditions. Their maximum ratings are 1000 V, 100 A, and 1 MHz. They can be used in low power converters. Since these are majority carriers like Schottky diodes, are more efficient for low voltage applications.

- Advantage: Voltage controlled turn ON/OFF, low switching losses, and high switching speeds.
- Disadvantage: Low voltage and current ratings and high on-state losses.

**Insulated Gate Bipolar Transistor (IGBTs).** Designed in the 1970s, IGBTs combine the fast switching speeds of MOSFETs with the low on-state losses and higher voltage and large current carrying capability of BJTs. They have maximum ratings of 4500 V, 3000 A, and 30 kHz. They are the preferred devices in medium voltage applications.

- Advantages: Medium voltage and current ratings, voltage controlled turn ON/OFF, fast switching and low on-state losses.
- Disadvantages: Medium switching speeds.

**Gate Turn-Off Transistors (GTOs).** Designed in the 1960s, GTOs will conduct only in the forward direction upon command of a control signal, but will turn OFF when a control signal is applied. The turn OFF control signal is usually one-third of the forward current. A drawback with GTOs is its small reverse voltage blocking capability (20-30 V). Additional circuitry is needed to block significant voltages. They are used in ac-dc and dc-dc converters and inverter circuits. Ratings are 6 kV, 6 kA, and 10 kHz.

- Advantage: Medium voltage and current ratings and controllable turn ON/OFF.
- Disadvantage: Slow switching speeds, very large gate current for turn OFF, and low voltage reverse blocking capability.

**Gate Commutated Transistor (GCTs).** Designed in the 1990s, this is an experimental device that operates similarly to a GTO but requires a small current signal applied to the gate to turn the device off. Ratings are 6 kV, 6 kA, and 10 kHz.

- Advantage: Medium voltage and current ratings and small gate current for turn-on/off.
- Disadvantage: Slow switching speeds and low reverse voltage blocking capability.

**Emitter Turn-Off Thyristor (ETO).** An ETO, designed in the 1990s, is an experimental device that is similar to a GTO but differs by voltage control signal for turn-off operation and faster switching speeds. Maximum ratings are 6 kV, 10 kA, and 20 kHz.

- Advantage: Medium voltage and high current ratings and small gate voltage for turn ON/OFF.
- Disadvantage: Medium switching speeds and complex construction

**MOS Controlled Thyristor (MCT).** Designed in 1984, an MCT is a device that combines low on-state losses, large current capability, and voltage blocking capability of a thyristor with the advantages of fast switching speeds of a MOSFET. These were designed to replace IGBTs but were not successful because of advances in IGBT technology. Maximum ratings are unavailable.

- Advantage: High voltage and current ratings, low on-state losses, fast switching speeds, and small gate voltage for turn ON/OFF.
- Disadvantage: Experimental (no manufacturing), complex fabrication, low yield for large dies, and predominant turn OFF failures.

**Junction Field Effect Transistor (JFET).** The JFET, designed in the early 1980s, is an experimental device designed to have faster switching speeds and lower on-state losses than a

MOSFET. Silicon JFETs are not suitable for power electronics because of their low voltage ratings; however, some experimental medium voltage silicon carbide JFETs are available for power applications.

- Advantage: Fast switching speeds, low on-state resistance, and small gate voltage for turn ON/OFF.
- Disadvantage: Normally ON device, low voltage and current ratings, and SiC JFETs are in the experimental stage.

## C.2 Power Electronics Device Manufacturers

	Company	Product	Rating	Others
1	Powerex, Inc.	IGBT Modules	250V-6500V, 10A-2400A	Powerex is 46% owned by Mitsubishi and 46% by GE.
		Phase Control SCRs	200V-6500V, 40A-5000A	
		Inverter Grade SCRs	200V-2500V, 40A-3000A	
		GCT/SGCT/GTO	2500C-650V, 400A-6000A	
2	Mitsubishi Electric & Electronics USA, Inc.	IGBT Modules	Up to 4500V, 2400A	Powerex Inc. is responsible for the sales and support for Mitsubishi power devices in North America.
		GTOs	2500V/4500V/6000V,1000A-6000A	
		GCTs	4500V/6000V/6500V,400A-6000A	
		Thyristors	Up to 12000V, 2500A	
3	IXYS Corporation	IGBT Discretes	1200V, 150A/100A	
		IGBT Modules	Up to 6500V, 1800A	
		Thyristors	Up to 4900V, 180A	
	Westcode Semiconductors	IGBT Press-packs	2500V/4500V/5200V, 160A-1500A	Westcode Semiconductors Company was acquired by IXYS Corporation in December 2001.
		GTOs	1700V-6000V, 500A-4000A	
		Distributed Gate Thyristors	Up to 5200V, 3000A	
		Phase Control Thyristors	3200V-6500V, Up to 4000A	
4	ABB Semiconductors Inc.	IGBTs	1200V-6500V, 100A-2400A	The IGCTs rating 10000V is in planning.
		GTOs	2500V-6000V, 1500A-4000A	
		IGCTs	2500V-6000V, 275A-4000A	
		Thyristors	1200V-6500V, 300A-4500A	
5	International Rectifier (IR)	IGBT Discretes	1200V, 99A	
		IGBT Co-packs	1200V, 120A/99A	
6	Advanced Power Technology, Inc.	IGBT Discretes	1200V, 100A	
		IGBT Modules	1200V/1700V, Up to 600A	
7	Eupec Inc.	IGBT Modules	Up to 6500V, 3600A	
		SCR/Diode Modules	Up to 4400V, More than 1000A	

	Company	Product	Rating	Others
8	Fuji Semiconductor	IGBT Modules	1200V/1400V/1700V/1800V, Up to 800A	
9	Sensitron Semiconductor	IGBT Modules	1200V, 100A/200A	
10	Infineon Technologies	IGBT Discretes	1200V,100/150A; 1700V,100/125/150A	
11	Toshiba Corporation's Semiconductor Company	IGBT Modules	1700V, 1200A; 2500V, 1000A	The IEGTS rating 6500V,600A is under planning.
		IEGTS	3300V,400A-1200A;4500V,900A-2100A	
12	SEMIKRON Inc.	IGBT Modules	1200V/1700V, Up to 960A	
		Thyristors	Up to 2200V, 2000A	
13	Hitachi America, Ltd.	IGBT Modules	1700/2000/2500/3000/4500V,Up to 2400A	
14	Dynex Semiconductor	IGBT Modules	1200V/1700V/3300V/6500V,Up to 3600A	
		GTOs	1300/1800/2500/4500/6500V,Up to 4000A	
		Thyristors	Up to 6500V, 1300A	

### C.2.1 Powerex, Inc.

200 E. Hillis Street  
Youngwood, PA 15697  
www.pwrx.com

Powerex provides devices used in power electronics applications ranging from power generation and industrial production to information processing and electrical home appliances. Powerex offers the combined corporate expertise of GE and Westinghouse each owning 46% of Powerex.

Powerex's mission is to be the leading supplier of discrete and modular high power semiconductors worldwide. Now it has 90,000 sq. ft manufacturing facilities, 15,000 sq. ft. office area, 15,000 sq. ft. warehousing/distribution, and 325 employees.

Powerex offers IGBT modules with voltage rating, 250V-6000V, current rating, 10A-2400A; IPM with 600V-3300V, 10A-2400A; and GCT/SGCT/GTO with 2500V-6500V, 400A-6000A.

### C.2.2 Mitsubishi Electric and Electronics USA, Inc.

Semiconductor Division  
5201 Great America Parkway Suite 332  
Santa Clara, CA 95054-1127  
www.mitsubishichips.com  
Phone: 408.727.3111  
Fax: 408.727.2689

Mitsubishi power devices are widely applied to various fields, such as industrial, electric railway, office automation, household power appliances and motor controls. For the power devices, Mitsubishi also plans to improve energy efficiency, develop the technology for reduction of power consumption, and increase the product lineup.

In order to meet the needs precisely, Mitsubishi is now accelerating the improvement of its existing devices and the research and development of new devices. Mitsubishi is developing and commercializing diodes, thyristors, IGBT modules, IPMs, and power MOSFETs in particular.

- IGBTs Specifications: 600V-1700V, 10A-1000A
- Thyristors: 400V-1600V, 20-400A

### **C.2.3 IXYS Corporation**

3540 Bassett Street  
Santa Clara, CA 95054  
www.ixys.com  
Phone: 408-982-0700

IXYS Corporation, is a supplier of power semiconductors and integrated circuits targeted to worldwide industrial, telecommunications, computer, and medical markets.

Founded in 1983, IXYS established a product portfolio of higher voltage, high efficiency, discrete power MOSFETs and IGBTs, as well as power interface integrated circuits (ICs). In 1989, IXYS acquired ABB's German semiconductor division, which expanded the company's high-power products and gave it a solid manufacturing and sales presence in the European marketplace.

IXYS offers discrete and module power semiconductors such as power MOSFETs and IGBTs, thyristors, and diodes (FRED, Schottky, GaAs, and Standard) and power interface ICs. Its phase control thyristors are of 800–2200 V range and 16–180 A current range. The latest discrete 1700-V IGBT copacks with new soft recovery SONIC-FRD diodes provide a lower-cost solution using standard PCB assembly for a broad range of high-voltage applications. These high-speed "A" copacks and phase legs are intended for high voltage, fast switching applications such as induction heating, induction cooking, 480 to 575-Vac offline inverters, flyback power supplies, uninterruptible power supplies, and microwave ovens.

### **C.2.4 ABB Semiconductors, Inc.**

575 Epsilon Drive  
Pittsburgh, PA 15238  
www.abb.com  
Phone: 412.967. 5860  
Fax: 412.967.5868

ABB provides power and automation technologies that enable utility and industry customers to improve performance while lowering environmental impact. The ABB Group of companies operates in around 100 countries and employs around 102,000 people.

ABB offers a wide variety of high power semiconductors using conventional and future oriented technologies with high reliability fulfilling the demand of the traction, industry and energy transmission segments. This product portfolio comprises GTOs, IGBTs, IGCTs, thyristors and diodes in the power range of 300–12000 A and 200–8500 V at the highest levels of quality.

### **C.2.5 International Rectifier (IR)**

233 Kansas St.  
El Segundo, CA 90245  
www.irf.com  
Envision L.L.C  
Email: [tovercash@envisionllc.com](mailto:tovercash@envisionllc.com)  
Phone: 770.638.8998  
Fax: 770.638.2998

International Rectifier (IR) manufactures a wide range of IGBTs. IR has targeted its products to almost all high-voltage, high-current, moderate-frequency applications. IR IGBTs offer higher current densities than equivalent high-voltage power MOSFETs and are faster with superior drive and output characteristics than comparable power bipolar transistors. In 1999, IR introduced NPT technology for IGBT reducing power losses by 20% and significantly improving cost and manufacturability. In 2001, the family expanded to include 600V devices.

### **C.2.6 Advanced Power Technology, Inc.**

405 S.W. Columbia Street  
Bend, OR 97702  
www.advancedpower.com  
Phone: 541.382.8028  
Fax: 541.388.0364

Advanced Power Technology (APT) designs, manufactures, and markets high power, high voltage, high performance semiconductors for both switching and RF applications. The Company's technologies and products are specifically focused at meeting the increasing demand for more sophisticated forms of electrical power, more power overall, and more efficient utilization of electricity to conserve this valuable resource.

- APT offers MOSFETs, IGBTs, Diodes, Power Modules and RF Transistors.
- IGBTs Specifications: 600V/1200V, up to 100A

### **C.2.7 Eupec, Inc.**

1050 Route 22  
West Lebanon, NJ 08833  
www.eupec.com

Dorel Ciornei  
District Sales Manager  
[Dorel.Ciornei@eupec.com](mailto:Dorel.Ciornei@eupec.com)  
Phone: 281.374.7622  
Fax: 281.374.7621

Eupec Inc. develops and produces power semiconductors as modules and discs. Lately, the product spectrum also includes IGBT drivers and sub-systems for various power electronic applications.

Eupec's power semiconductors are used in power electronic applications ranging from 0.5 kW to more than 1 GW, typically in the following applications: IGBT high-power/high-voltage modules for medium-voltage drives and traction applications; IGBT modules and power



integrated modules for standard industrial drives, wind-power generators, and power supply units; IGBT modules for compact low-power-applications; fast-switching IGBT modules for use in high-frequency applications such as inductive heating, medium frequency welding, X-ray inverters; thyristors and diodes in presspack configuration for use in high-current applications such as energy transmission, power supply, drives, welding technologies, and electrolysis; sub-assemblies consisting of power semiconductors, suitable heat sinks, and snubber components, connected in standard configurations.

- IGBT specifications: up to 600V-6500V, 50A-1200A

### **C.2.8 Fuji Semiconductor, Inc.**

2532 Highlander Way  
Carrollton, TX 75006  
www.fujisemiconductor.com  
Email:applications@fujisemiconductor.com  
Phone: 972.733.1700  
Fax: 972.381.9991

Fuji Semiconductor, Inc., was established in 2001 to provide sales and marketing of Fuji Electric's semiconductor products in North and South America.

Fuji Semiconductor, Inc. product line includes IGBT (Modules and Discretes), IPM (Intelligent Power Module), MOSFET and Smart MOSFET, Bipolar Transistors (Modules and Discretes), Power Management ICs, Sensor ICs, and Driver ICs (CMOS) Diodes: Fast Recovery, Schottky, and High Voltage and Surge Absorbers.

- IGBTs Specifications: 600V/1200V/1400V/1700V, 2.5A-800A

### **C.2.9 Sensitron Semiconductor**

221 West Industry Court  
Deer Park, NY 11729-4681  
www.sensitron.com  
Email: comm.sales@sensitron.com  
Phone: 631.586.7600  
Fax: 631.242.9798

Sensitron Semiconductor is a privately held company, founded in 1969 and located on Long Island in Deer Park, New York. The facility includes a wafer fabrication clean room and a microelectronics manufacturing clean room.

Sensitron has a complete staff of engineers whose specialties include design, process materials, electrical, packaging, and testing, which have all the necessary tools to develop, design and manufacture semiconductor and microelectronics products.

Sensitron offers discrete IGBTs/IGBT modules applied in motion control, ac motor drive and static power conversion.

### **C.2.10 Infineon Technologies North America Corp.**

1730 North First Street,  
San Jose, CA 95112  
[www.infineon.com](http://www.infineon.com)  
Interep Associates, Inc.  
Phone: 256.881.1096  
Fax: 256.881.1182

Infineon designs, develops, manufactures and markets a broad range of semiconductors and complete system solutions targeted at selected industries.

Their products serve applications in the wireless and wireline communications, automotive, industrial, computer, security and chip card markets. The product portfolio consists of both memory and logic products and includes digital, mixed-signal and analogue integrated circuits (ICs) as well as discrete semiconductor products and system solutions.

- IGBTs Specifications: 600V, 100/150/200A; 1200V, 100/150A; 1700V, 100/125/150A;

### **C.2.11 Toshiba Corporation's Semiconductor Company**

19900 MacArthur Boulevard, Suite 400,  
Irvine, CA 92612,  
[www.semicon.toshiba.co.jp/eng/index.html](http://www.semicon.toshiba.co.jp/eng/index.html)  
Phone: 949.623.2900

- IGBTs Specifications: 1700V, 1200A; 2500V, 1000A
- IEGTs Specifications: 3300V, 400A/800A/1200A; 500V, 600A-2100A; 6500V, 600A

### **C.2.12 SEMIKRON, Inc.**

11 Executive Drive  
Hudson, NH 03051  
[www.semikron.com](http://www.semikron.com)  
E-Mail: [gary.genet@semikron.com](mailto:gary.genet@semikron.com)  
Phone: 404.713.0364  
Fax: 678.797.9514

SEMIKRON is a manufacturer of power electronics, is the European leader in power modules, providing 33% of the market share and a leader in diode/thyristor modules with a market share of 22%.

There are 11600 different semiconductors in the product range from 1 W to several MW. SEMIKRON's product range in the area of power electronics includes chips, discrete diodes, thyristors, power modules (IGBT / MOSFET / diode / thyristor / CIB / IPM), driver and protection components and integrated subsystems.

- IGBT specifications: 600V/1200A/1700A, up to 960A
- IPM specifications: 1200V/170V, up to 2400A

### **C.2.13 Hitachi America, Ltd.**

Power and Industrial Division  
Industrial Components and Equipment [INC] Group  
50 Prospect Avenue  
Tarrytown, NY 10591  
www.hitachi.us  
Phone: 914.631.0600  
Fax: 914.631.3672

Hitachi is continuously developing new power device products. Hitachi presents a new IGBT module, 600 V / 1200 V / 1700 V / 2000 V / 2500 V / 3000 V / 4500 V, up to 2,400A. The new IGBT module makes possible higher efficiency and quieter operation of inverters.

### **C.2.14 Dynex Semiconductor**

www.dynexsemi.com  
Andy Meikle  
Email: power\_solutions@dynexsemi.com  
Phone: 440.259.2060  
Fax: 440.259.2059

Dynex Semiconductor is a supplier of products and services specializing in the field of power semiconductors and integrated circuit products.

Today the headquarters for Dynex Semiconductor, along with manufacturing, silicon fabrication, sales, marketing, design and research and development, are co-located in Lincoln, UK. This facility includes in excess of 4,000 square meters of recently refurbished clean rooms dedicated to the manufacture of power semiconductor products.

Dynex offers a range of IGBT modules and die products. The module family includes products with voltage ratings from 600V to 3,300V and current ratings from 200 to 3,600 A.

Dynex also manufactures a comprehensive range of phase control thyristors (SCR), Rectifier diodes, asymmetric and fast turn-off thyristors, GTOs, pulse power thyristors, and fast recovery diodes. Voltages range from 1200 V for direct connection to 416-V supplies to 6500 V for high-voltage applications. Average current ratings range from a few hundred amps to 11,000 A.

### **C.2.15 Fairchild Semiconductor Corporation**

82 Running Hill Road  
South Portland, ME 04106  
www.fairchildsemi.com  
Phone: 770.209.9242  
Fax: 770.209.9245  
IGBTs Specifications: 600V, 100–400 A

### **C.2.16 STMicroelectronics**

Industrial, R&D and design center Phoenix  
1000 East Bell Road  
Phoenix, AZ 85022  
www.stmicroelectronics.com  
Phone: 602.485.6100  
Fax: 602.485.6102

STMicroelectronics develops and delivers semiconductor solutions across the spectrum of microelectronics applications. The ST product range includes MOSFETs, bipolar transistors, IGBTs, and triacs.

## Appendix D. SiC POWER ELECTRONIC DEVICES

A wide variety of SiC power devices have been developed, including diodes, BJTs, GTOs, MGTs, MOSFETs, and IGBTs. Generally, these devices fall into categories—unipolar and bipolar or two- and three- terminal devices as shown as Fig. D.1. In the following sections, each device is described in detail. The devices reported experimentally are also tabulated.

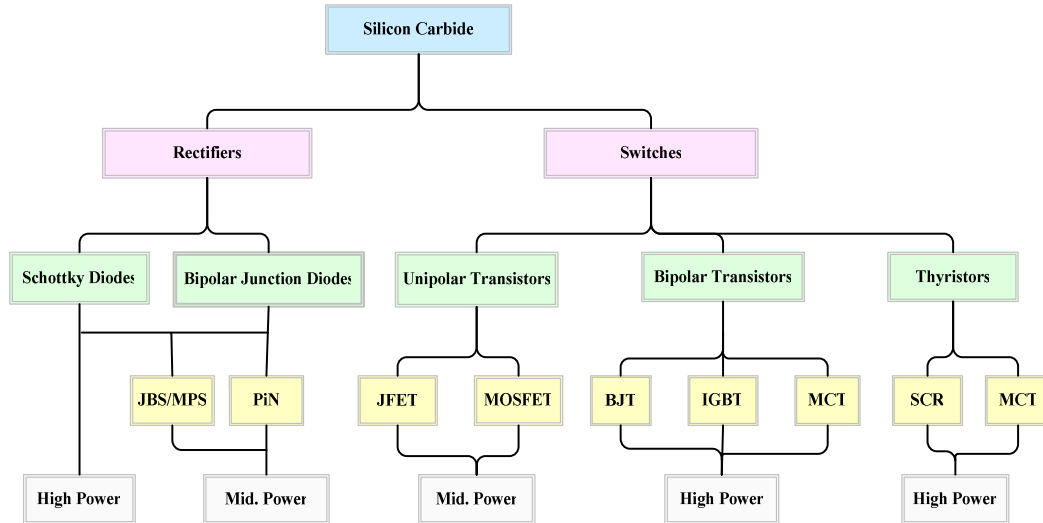


Fig. D.1. SiC power electronics components.

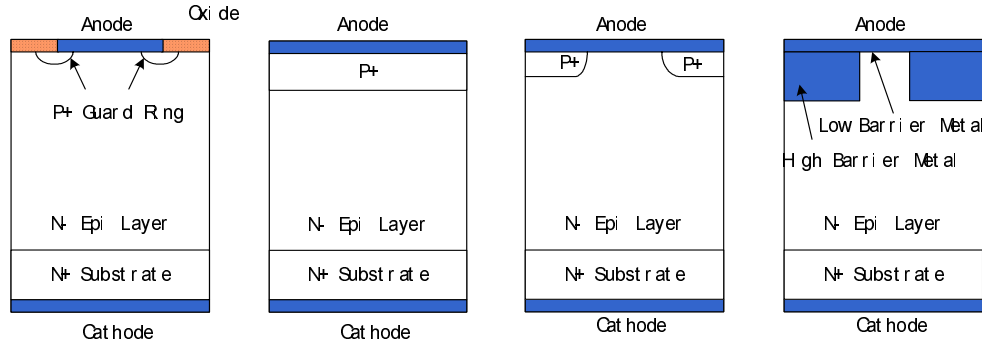
### D.1 Power Diodes

Numerous structures have been demonstrated for Si-based power rectifiers, which are categorized into two classes — the unipolar Schottky rectifiers and the bipolar junction rectifiers. Schottky rectifiers offer fast switching speed but suffer from a high on-state voltage drop and on-resistance because mostly majority carriers participate in forward conduction. By contrast, the PiN junction rectifier has low forward drop and high current capability due to conductivity modulation, but has slow reverse recovery characteristics due to minority carrier storage. To combine the positive features of these two rectifiers, hybrid rectifier structures such as the junction barrier Schottky (JBS), merged Pin/Schottky (MPS), trench MOS barrier Schottky (TMBS) rectifiers, SPEED, and SSD structures have been proposed and demonstrated for SiC [1]. Presently, SiC Schottky diodes are commercially available. PiN and MPS/JBS structures were also proposed to use in SiC power rectifiers. Reference [1] pointed out that a trench Schottky barrier Schottky (TSBS) is particularly suitable for SiC devices. These structures are sketched in Fig. D.2. A list of experimental results on SiC rectifiers is shown in Table D.1.

### D.2 Power Transistors

Similar to diodes, power transistors have two categories — unipolar and bipolar devices. MOSFETs and JFETs are unipolar devices, while BJT, IGBT, and MCT are bipolar devices.

Figure D.3 illustrates two basic designs of the power MOSFET, namely vertical trench U-shape MOSFETs (UMOSFET) and double-diffused MOSFET (DMOSFET). The first SiC power transistors were UMOSFET reported by Cree in 1992. The early demonstration should be attributed to its ease of fabrication which required no ion implantation or implant annealing steps. These steps are different for SiC due to the slow diffusion rates for dopants in it. The UMOSFET

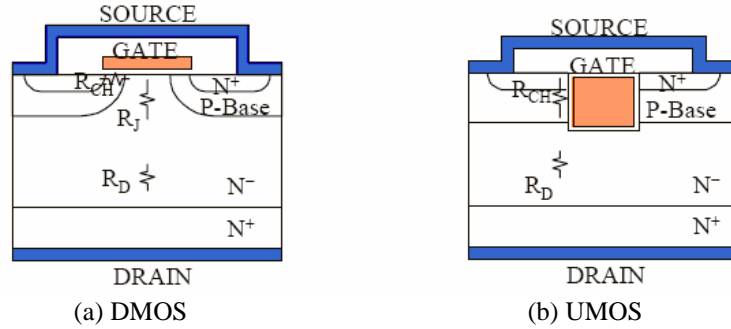


(a) Schottky structure (b) PiN structure (c) MPS/JBS structure (d) TSBS structure

**Fig. D.2. Structures of SiC power rectifiers.**

**Table D.1. SiC power rectifiers that have been demonstrated experimentally**

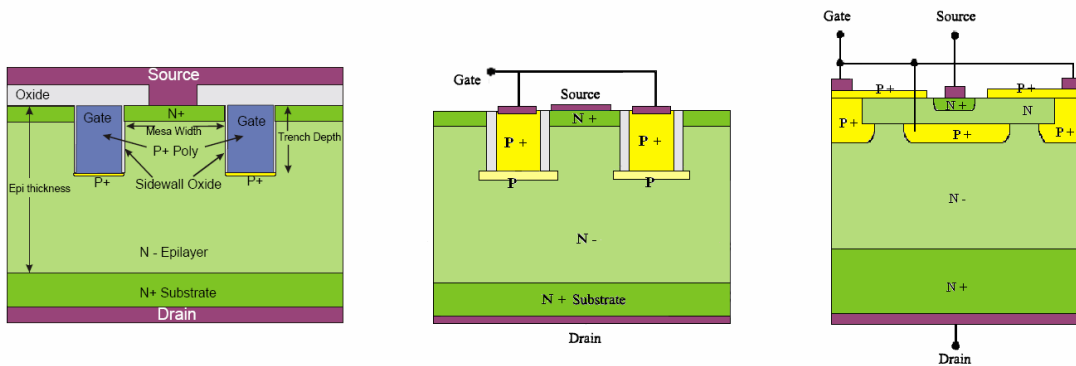
Device type	Polytype	Rating	Features	Developer, Year
Schottky	6H-SiC	400V		PSRC, 1992
	6H-SiC	1100V	Ni, Field plate term	U. of Cincinnati, 1995
	4H-SiC	1750V	Ti, C-Face, B+ edge term, $n=1.02$ , VF100=1.12V, $5\text{m}\Omega\text{-cm}^2$	Kyoto U., 1995
	4H-SiC	1720V	Ni, B+ edge term, $5.6\text{m}\Omega\text{-cm}^2$	Purdue U., 1997
	4H-SiC	3KV	Ni, Field plate term, VF100=7.1V, $34\text{m}\Omega\text{-cm}^2$ Is600=70 $\mu\text{A}$	Linköping U./ABB, 1997
	4H-SiC	1720V	VF100=2V, $5.6\text{m}\Omega\text{-cm}^2$	Purdue, 1998
	4H-SiC	1200V	VF150=1.9V, Is=300 $\mu\text{A}$	Rockwell, 2000
		300V/10A	Commercially available	Infineon, 2001
		600V/4,6 A	Commercially available	Infineon, 2001
		4H-SiC 130A	VF200=3.25V	Cree, Purdue, RPI, 2002
	4H-SiC 5kV	VF25=2.4V, $17\text{m}\Omega\text{-cm}^2$	Cree, Purdue, RPI, 2002	
	1200V	Commercially available	Cree, 2003	
PiN	6H-SiC	2000V, 1mA		NASA, 1993
	6H-SiC	4.5KV, 20mA	VF100= 6V	Linköping U./ABB, 1995
	6H-SiC	1325V	Floating field rings term.	ABB, 1995
	4H-SiC	3.4KV	JTE, VF100= 6V	ABB, 1997
	4H-SiC	> 5.5kV		Cree, 1998
	4H-SiC	2KV, 5A	JTE, VF500= 4.0V, $2.2\text{m}\Omega\text{-cm}^2$ , Al-implanted	Siemens, 1998
	4H-SiC	3KV, 7A	JTE, VF500= 4.8V, $3.0\text{m}\Omega\text{-cm}^2$ , Al-implanted	Siemens, 1998
	4H-SiC	600V	JTE, VF100= 6.0V, n+pp+ phosphorus-implanted	RPI, 1998
	4H-SiC	1.1KV	JTE, VF100= 3.4V, Al/C- and B-implanted	RPI, 1999
	4H-SiC	3.5KV	JTE, VF100 < 4V, Al- and B-implanted	ABB, 1999
	4H-SiC	> 4.5KV	JTE, VF100= 4.2V, Al/C- and B-implanted	RPI/GE, 1999
	4H-SiC	4.9KV	JTE, VF100= 4.2V, Al-implanted	Siemens, 1999
	4H-SiC	6 kV	VF100=4.2 V, VF500=5.8 V	Naval MURI, 2000
	4H-SiC	4.5 kV	VF100=3.08V, VF1000=4.10V	ABB, 2001
	4H-SiC	8.6kV	Ni, JTE, VF100=7.1V	Cree, Purdue, RPI, 2002
	4H-SiC	5.5kV	JTE, VF100=5.4V, $10\text{m}\Omega\text{-cm}^2$ , Is5500=250 $\mu\text{A}$	Cree, Purdue, RPI, 2002
4H-SiC	3kV/600A	Module, JTE, VF600=4.43V	Cree, 2002	
4H-SiC	600V/30A	Is600=70 $\mu\text{A}$	Cree, 2004	
4H-SiC	600V/80A	Packaged, Is600=125 $\mu\text{A}$	Cree, 2004	
4H-SiC	10kV/40A	VF=3.8V	DARPA WBGHPE, 2004	
MPS	4H-SiC	~ 750V	Ti, VF100~ 1.5V	Daimler-Benz, 1997
	4H-SiC	800V/140A	MJTE	Cree, 2001
JBS	4H-SiC	870/1KV	Ti, VF100= 3.1V, $19\text{mW}\text{-cm}^2$	Royal Inst./ABB, 1997
	6H-SiC	540/850V	Ti, VF100= 5.3V, $43\text{mW}\text{-cm}^2$	Royal Inst./ABB, 1997



**Fig. D.3. Basic structure of SiC MOSFETs.**

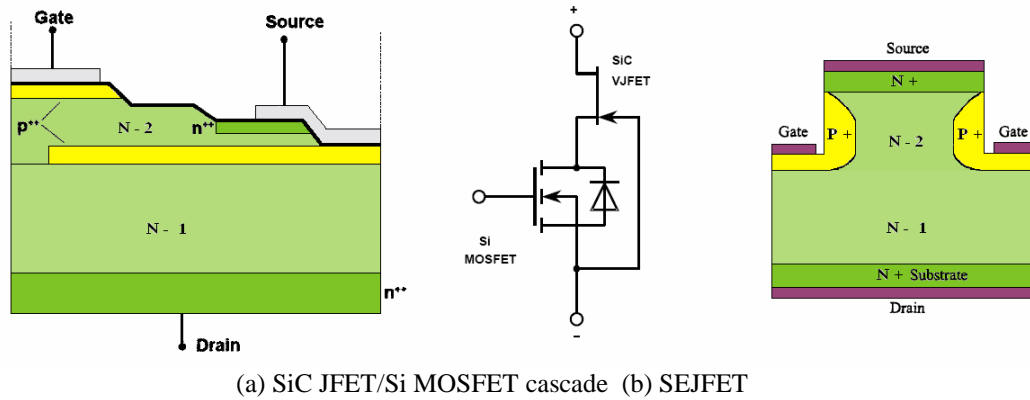
has a vertical channel along the MOS surface, whereas that of a DMOSFET is lateral. UMOSFET has a higher channel density (channel width per unit active area) than DMOSFET. Further, in the UMOSFET structure, the gate oxide can rupture due to the high electric fields developed at the trench corners as a result of the high breakdown electric field strength of the underlying semiconductor. Therefore, DMOSFET with the planar gate structure is preferable for SiC. However, the DMOSFET is not without its own problems. Activation of the implants that form the base and source regions requires annealing at temperatures in excess of 1500 °C. Depending upon the precise annealing conditions (time, temperature, and ambient), this anneal can create surface roughness through a process called step bunching. The surface roughness has been shown to severely degrade channel mobility in MOSFETs [2]. To overcome the high electric field in gate oxide and the poor inversion layer mobility in the channel of these two structures, a new design for SiC MOSFET is required.

A JFET is formed by using a PiN junction gate to take the place of a MOS-gate to control the carrier flow in the channel of the FET. Figure D.4 gives the basic structures of a SiC FET. JFETs have no critical gate oxide. This avoids several material science issues peculiar to MOSFETs, including channel mobility, oxide breakdown, and long-term reliability of the oxide. It can be said that JFETs are the easiest to fabricate among all the switches. However, JFETs are normally-on devices. Most power control systems require normally-off devices so that the system will fail in a safe condition should control power be interrupted. One way to solve this problem is to connect a SiC JFET in cascade with a normally-off device, such as a Si MOSFET. As shown as Fig. D.5(a), the SiC JFET blocks the high voltage, while the Si MOSFET provides normally-off gate control. One problem of this structure is that the Si part puts a relatively low temperature



(a) Trench VJFET (b) MOS-enhanced JFET (c) SEJFET

**Fig. D.4. Basic structures of SiC JFET.**



**Fig. D.5. Two normally-off structures of SiC JFET.**

limit. The structure shown Fig. D.5(b) is another normally-off design for all SiC devices, called static expansion channel JFET (SEJFET).

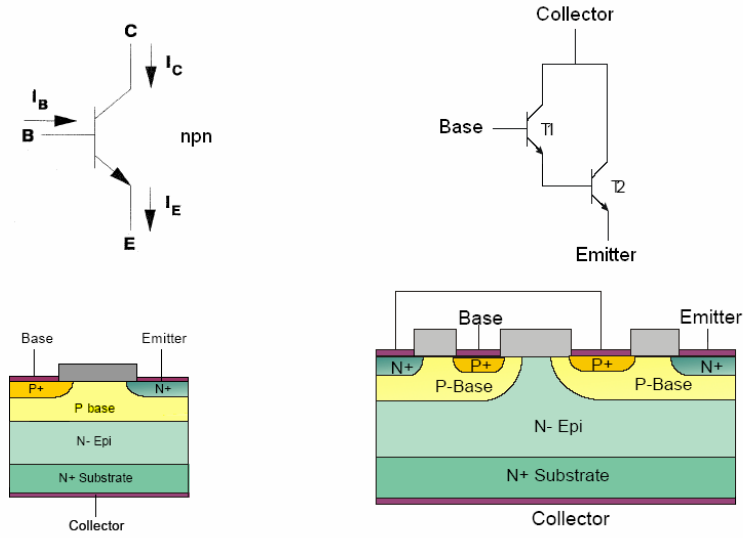
Si BJTs were the first true power electronic devices, but they were gradually replaced by Si MOSFETs and IGBTs. Unlike voltage controlled MOSFETs and JFETs, BJTs are controlled by current. At present, Si BJTs are no longer competitive because of secondary voltage breakdown, a complicated drive circuit, and resultant increased power dissipation due to current control.

But this is not the case for SiC. Since the critical field for avalanche breakdown in SiC is ten times higher than silicon, the drift region doping for blocking voltage is 100 times higher than in Si. This means the critical current density for secondary breakdown in SiC is also 100 times higher than in Si, thereby making secondary breakdown not a problem for SiC BJTs. At the same time, the higher critical field also brings higher current gain and faster switching [2]. Furthermore, compared to SiC MOSFETs, SiC BJTs avoid many of troubles associated with the gate oxide, including oxide breakdown under high field, oxide reliability at high temperatures (thereby higher operational temperature), and high field, low inversion layer mobility at the oxide/semiconductor interface. In many ways, BJTs are easier to fabricate than MOSFETs. Besides, SiC BJTs have better performance with lower on-state resistance than SiC MOSFETs due to conductivity modulation. Consequently, BJTs have become attractive again for SiC.

The main disadvantage of BJTs is high input base current during on state, which accounts for substantial power dissipation in the devices. Figure D.6 shows the structures of SiC BJTs that have been proposed in the literature. Si IGBT is the most popular Si bipolar transistor. As shown in Fig. D.7 (a), an n-channel UMOs IGBT is formed by a MOSFET connecting to the base of a bipolar transistor in a Darlington Configuration. The research that has been done on SiC IGBTs is very limited. Only several prototypes were demonstrated, which are listed in Table D.2. Note that, unlike Si, the p-channel IGBTs are more favorable for SiC than n-channel IGBTs due to its larger RBSOAs resulting from the larger hole ionization coefficient [3].

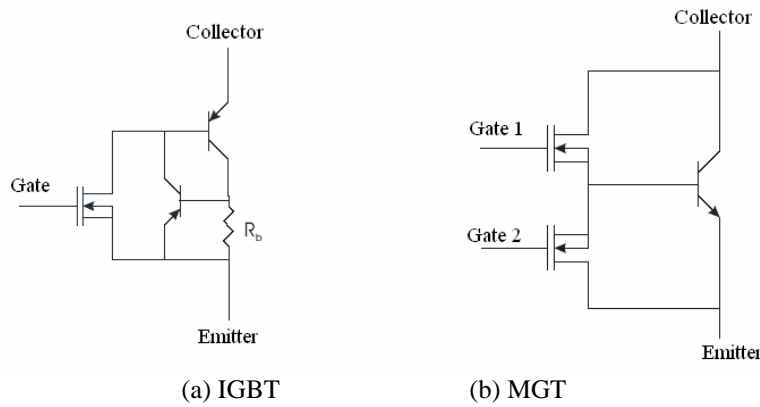
In addition, a MOS-Gated Transistor (MGT) structure was also proposed for SiC devices. It uses an n-channel MOSFET driving a narrow-base high-voltage npn transistor, as shown in Figure D.7(b). All the SiC power transistors that have been experimentally demonstrated are listed in Table D.2.





(a) BJT (b) Darlington

**Fig. D.6. Structures of SiC BJTs.**



(a) IGBT

(b) MGT

**Fig. D.7. Equivalent circuits for proposed SiC devices.**

**Table D.2. Prototype SiC power transistors that have been demonstrated experimentally**

Device type	Polytype	Power rating	Features	Developer
MOSFET	6H-SiC	60V, 125mA	UMOS, 38mW·cm <sup>2</sup>	Cree, 1993
	4H-SiC	150V, 150mA	UMOS, 33mW·cm <sup>2</sup>	Cree, 1993
	4H-SiC	260V, 100mA	UMOS, 18mW·cm <sup>2</sup>	Cree, 1995
	4H-SiC	1100V	UMOS, 74mW·cm <sup>2</sup> @100°C	Northrop Grumman, 1997
	4H-SiC	1400V	UMOS, 311mW·cm <sup>2</sup>	Kansai Elec., 1998
		1200V/12A	UMOS, 16mW·cm <sup>2</sup>	Rockwell, 2004
	6H-SiC	760V, 3mA	DMOS, 125mW·cm <sup>2</sup>	Purdue U., 1996
	4H-SiC	900V	DMOS	Northrop Grumman, 1997
	6H-SiC	550V, 1A	DMOS, 25mW·cm <sup>2</sup>	Siemens, 1997
	6H-SiC	1800V, 0.45A	Triple-Implanted DMOS, 82mW·cm <sup>2</sup>	Siemens, 1999
6H-SiC	600V, 5A	Triple-Implanted DMOS, 22mW·cm <sup>2</sup>	Siemens, 1999	
6H-SiC	1600V, 1A	Triple-Implanted DMOS, 40mW·cm <sup>2</sup>	Siemens, 1999	
6H-SiC	600V	Triple-Implanted DMOS, 40mW·cm <sup>2</sup>	Siemens, 1999	

**Table D.2. (continued)**

Device type	Polytype	Power rating	Features	Developer	
	4H-SiC	2000V	Self-Aligned Vertical short-channel DMOS, 27-33m $\Omega$ -cm <sup>2</sup>	Purdue, 2002	
	4H-SiC	10kV/1.3A	DMOS, 123m $\Omega$ -cm <sup>2</sup>	DARPA WBGHPE, 2004	
	6H-SiC	1800V	47m $\Omega$ -cm <sup>2</sup>	Siemens, 2000	
	4H-SiC	1200V	VF=2V@0.5A/25°C, 1.3V@0.5A/125°C	SiCED, 2002	
BJT	6H-SiC	20V, 20mA	$\beta$ ~10, 126 m $\Omega$ -cm <sup>2</sup>	Cree, 1993	
	6H-SiC		$\beta$ =36, VF=1V@50A/cm <sup>2</sup>	RPI, 2000	
	4H-SiC	500V(700V)	$\beta$ >50, 26 m $\Omega$ -cm <sup>2</sup>	Purdue, 2002	
	4H-SiC	500V/23A	$\beta$ =430	Rutgers Univ., 2004	
	4H-SiC	9.2kV	150A/cm <sup>2</sup> , 33/49 m $\Omega$ -cm <sup>2</sup>	Rutgers Univ., 2004	
IGBT	6H-SiC	200V, 1mA	Self-aligned UMOS	RPI/GE, 1996	
	4H-SiC	800V	Self-aligned UMOS, p-channel	RPI, 1997	
	4H-SiC	100mA	UMOS, p-channel	Cree, 1998	
	4H-SiC	1.4A	UMOS, p-channel	Cree, 1999	
	4H-SiC	2.6KV, 1 $\mu$ A	Lateral DMOS	Purdue U., 1997	
	4H-SiC	1200V, 1mA	Lateral RESURF, 4W-cm <sup>2</sup>	RPI, 1999	
	6H-SiC	500V	Lateral RESURF, 40mW-cm <sup>2</sup>	NRL/Northrop Grumman, 1999	
	6H-SiC	400-475V	Lateral RESURF, ~0.29-0.77 m $\Omega$ -cm <sup>2</sup>	Naval Res., 1999	
	6H-SiC	1300V	Lateral RESURF, 160 m $\Omega$ -cm <sup>2</sup>	RPI, 2000	
	4H-SiC	450V, 100mA	Accumulation mode FET, 11mW-cm <sup>2</sup>	Denso, 1997	
	6H-SiC	350V, 100mA	Accumulation mode FET, 18mW-cm <sup>2</sup>	N. Carolina SU, 1997	
	4H-SiC	450V, 5mA	Accumulation mode FET, 32mW-cm <sup>2</sup> , 128mW-cm <sup>2</sup> @150°C	N. Carolina SU, 1998	
		4H-SiC	850V, 25mA	Accumulation mode FET, 27mW-cm <sup>2</sup>	Purdue U., 1998
		4H-SiC	1100V	Implantation and epitaxial MOS(IEMOS), 4.3 m $\Omega$ -cm <sup>2</sup>	PERC-AIST, 2004
JFET	4H-SiC	550V, 6A	Cascoded with Si MOSFET, 18mW-cm <sup>2</sup>	Siemens, 1999	
	4H-SiC	950V, 1.2A	Cascoded with Si MOSFET, 40mW-cm <sup>2</sup>	Siemens, 1999	
	4H-SiC	600V, 1000V	18-40 m $\Omega$ -cm <sup>2</sup>	Siemens, 1999	
	4H-SiC	1800V	Vertical, 14.5m $\Omega$ -cm <sup>2</sup>	Siemens, 2000	
	4H-SiC	5.55kV	Static Expansion channel JFET (SEJFET),	Kansai Elec., 2001	
	4H-SiC	5.3kV/3.3A	218 m $\Omega$ -cm <sup>2</sup>	Kansai Elec., 2002	
			400V/4A	SEJFET, normally-off, 69m $\Omega$ -cm <sup>2</sup>	MSU, SemiSouth, 2002
			600V/20A	n-channel trench VJFET, 4.5m $\Omega$ -cm <sup>2</sup>	Rockwell, 2002
	4H-SiC	1726V	MOS-enhanced, normally-on, 2.86m $\Omega$ -cm <sup>2</sup>	State Univ. of New Jersey, 2003	
			Vertical, normally-off, VF300=3, 3.6 m $\Omega$ -cm <sup>2</sup>		
			8kV/10A		SiCED, 2003
	4H-SiC	800V	Stacked VJFETs	Sumitomo Elec., 2004	
		1200V	Resurf-type, 50m $\Omega$ -cm <sup>2</sup>	Cambridge, 2004	
		1200V/3A	Double channel normally-off trench, 2.6m $\Omega$ -cm <sup>2</sup>	Rockwell	
		1200V/7.5A		Rockwell	
MGT	4H/6H-SiC		VF=5V@ 50A/ cm <sup>2</sup>	RPI, 2002	

### D.3 Power Thyristors

Most of research on SiC thyristors has been done on SiC Gate turn-off thyristor (GTO), which uses gate current to facilitate turn-off without device commutation. Figure D.8 is the proposed structure. Table D.3 gives a list of SiC thyristors that have been demonstrated experimentally [4]. Figure D.9 shows reported on-current vs. blocking voltages for SiC power devices.

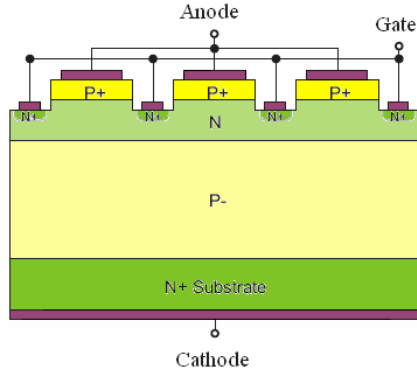


Fig. D.8. Cross-section of asymmetrical SiC GTO.

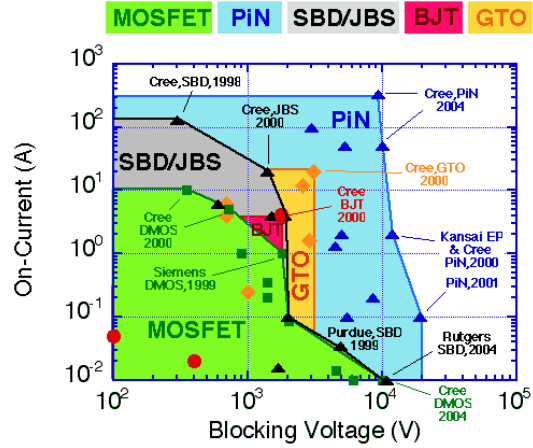


Fig. D.9. Absolute on-current vs. blocking voltage for SiC power devices reported as of 2004.

Table D.3. SiC thyristors that have been demonstrated experimentally

Device type	Polytype	Power rating	Features	Developer
Thyristor	6H-SiC	100V, 20mA	Gate Triggered	Cree, 1993
	6H-SiC	100V, 1.8A	GTO, $V_{F100} = 2.9V$ , $J_{max} = 5200A/cm^2$	ARL, 1995
	4H-SiC	900V, 2A	Gate Triggered, $0.82 mW/cm^2$	Cree, 1996
	6H-SiC	100V	Pulse current density $5200A/cm^2$	RPI, 1996
	4H-SiC	600V, 4.2A	GTO, Involute Gate, $V_F = 4.5V @ 1600A/cm^2$	Northrop Grumman, 1997
	4H-SiC	1000V	$V_F = 4.4V @ 1000A/cm^2$ , $3.6V @ 390^\circ C$	Northrop Grumman, 1997
	4H-SiC	600-800V	$V_F = 4.8V @ 500A/cm^2 / 350^\circ C$	Northrop Grumman, 1997
	4H-SiC	600V/1.4A	4 cells packaged in parallel	Northrop Grumman, 1997
	4H-SiC	600V	Implanted p+ Emitter	RPI, 1997
	4H-SiC	1100V	GTO, $V_{F100} \sim 5V$	GE/RPI, 1999
	4H-SiC	600V	Implanted n Base	RPI, 1999
	4H-SiC	2600V, 12A	GTO, $V_{F100} \sim 4V$	Cree, 1999
	4H-SiC	1770V/>100A	Asymmetrical, $V_F = 4V @ 100A / 200^\circ C$	Cree, 2005
	4H-SiC	3.1kV/100A	GTO, $3 m\Omega/cm^2$	Northrop Grumman, 2002

## D.4 Cost-Effectiveness of SiC Power Electronics in Utility Applications

As the analysis in the first part, the application of SiC power electronics in utilities, including power electronics interface, flexible ac transmission system (FACTS), and high-voltage dc system (HVDC), can improve system efficiency, and reliability and reduce system weight and volume, as well as complexity of temperature, at the same time. Unlike electric vehicle applications, utility applications are not so sensitive to component cost. Take the HVDC application presented in paper [5] as an example. The following paragraphs present its cost-effectiveness analysis.

Paper [5] ran simulations on SiC, Si GTO/PiN diode, and hybrid converters (Si GTOs, SiC diodes) and compared the power losses and efficiency of these systems. The simulation details are given in Table D.4.

**Table D.4. GTO/diodes converter specification**

System ratings: 120 kV dc link, up to 75 MW delivered to the receiving end.
Device ratings: SiC – 20kV, 200 A/cm <sup>2</sup> ; Si – 5kV, 200A/cm <sup>2</sup>
Number of devices to achieve system rating: SiC – 396, Si – 1560
System frequency is 60 Hz, GTO thyristor switching frequency is 2 kHz
Simulation temperature range: 27 °C – 200 °C.

From Table D.5, the efficiency of the SiC converter is higher compared to the Si converter and the difference becomes significant at higher temperatures. This is because of the difference in losses of the SiC and Si devices. As expected, the hybrid converter has an efficiency between them. In addition, a small increase in efficiency of the SiC is a significant factor considering the fact that several megawatts of power are being delivered.

**Table D.5. Simulation results for Si/SiC/hybrid converter efficiency from paper [5]**

Temp (K)	Si Converter			SiC converter			Hybrid converter		
	P <sub>loss,GTO</sub>	P <sub>loss,diode</sub>	Eff (%)	P <sub>loss,GTO</sub>	P <sub>loss,diode</sub>	Eff (%)	P <sub>loss,GTO</sub>	P <sub>loss,diode</sub>	Eff (%)
300	433.3	672.26	98.54	475.2	1326.8	99.37	433.3	1326.8	99.00
373	1443.1	674.12	97.32	1245.6	1344.9	99.14	1443.1	1344.9	97.78
423	3041.2	675.03	95.40	2402.1	1392.0	98.77	3041.2	1392.0	95.84
473	6301.9	676.40	91.49	4506.9	1451.8	98.12	6301.9	1451.8	91.92

The improvement of the efficiency of the SiC or the hybrid converter mainly results from the reduction of power losses in the devices. Based on data in Table D.4, system cost can be estimated. Assume that a converter operates for 365 days/year and 24 hours/day, and the rate of electricity is \$0.04/kWh, difference in losses are  $P_{loss} = P_{loss,SiC} \times N_{SiC} - P_{loss,Si} \times N_{Si}$ ,  $N_{SiC}$  and  $N_{Si}$  are the number of devices, difference in energy loss/year,  $E_{loss/yr} = P_{loss} \cdot 365 \times 24$ , then savings/year =  $(E_{loss/yr}) (\$/0.04)$ .

Results at 100°C, corresponding to 373 K, were calculated and shown in Table D.6.

**Table D.6. System savings of different converter (per year)**

Converter	Average losses (kW)	Annual power savings (kWh)	Annual savings (\$)
SiC/Si	1091	9,553,537	382,141
Hybrid/Si	275	2,486,215	96,249

Both SiC and hybrid converters can have a big annual savings compared to a Si converter. The savings of the hybrid converter is about 1/4 that of the SiC converter, but still significant. Furthermore, these big savings make SiC and hybrid converters competitive with Si converters though they are more expensive. The results in Table D.6 do not include the savings from less expensive passive components, thermal management system, and the additional power loss caused by them. Applications of SiC devices reduce expense and save energy at the same time. Therefore, there are great opportunities use SiC devices in utility applications.

## D.5 References

1. B.J Baliga, "The Future of Power Semiconductor Device Technology," *Proceedings of the IEEE*, Vol. 89, Issue 6, June 2001, pp. 822–832.
2. J.A. Cooper and A. Agarwal, "SiC Power-Switching Devices—The Second Electronics Revolution?" *Proceedings of the IEEE*, Vol. 90, Issue 6, June 2002, pp. 956–968.
3. P.J. Wellmann, "Additional Pipework Opens up Transistor Applications for SiC," *Compound Semiconductor*, March 2005.
4. T.P. Chow, V. Khemka, J. Fedison, N. Ramungul, K. Matocha, Y. Tang, and R.J. Gutmann, "SiC and GaN Bipolar Power Devices," *Solid-State Electronics* **44**, 2000, pp. 277–301.

5. Madhu Chinthavali, Leon M. Tolbert, Burak Ozpineci, "4H-SiC GTO Thyristor Loss Model for HVDC Converter," *IEEE Industry Applications Society Annual Meeting*, October 3-7, 2004, Seattle, Washington, pp. 1238-1243.

## Appendix E. INTRODUCTION OF SEMICONDUCTOR MANUFACTURING PROCESS

The fundamental manufacturing processing steps of semiconductors are shown in Fig. E.1.

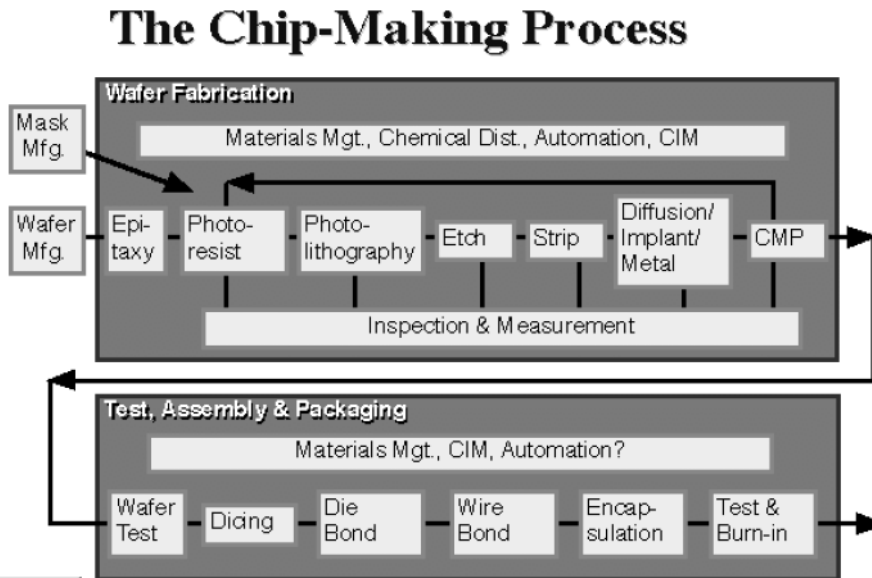
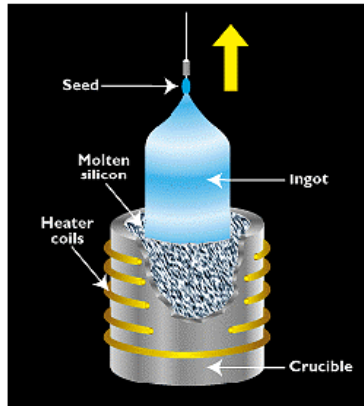


Fig. E.1. The basic steps of device manufacturing process (Infrastructure).

The manufacturing process of several different semiconductors being considered for power electronics is graphically shown in the following sections (Sects. E.1–E.4 and Figs. E.2–E.10).

## E.1 Silicon (Si) Manufacturing Process



### Silicon Manufacturing process

- ◆ **Czochralski Process** is a Technique in Making Single-Crystal Silicon
- ◆ A Solid Seed Crystal is Rotated and Slowly Extracted from a Pool of Molten Si

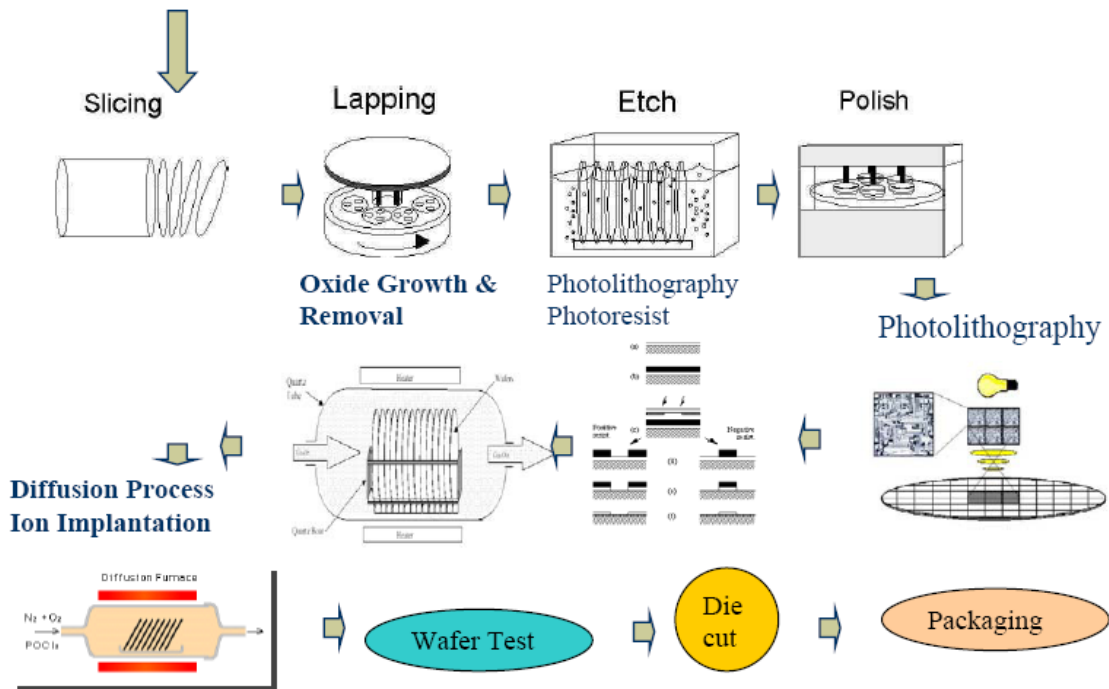


Fig. E.2. The basic steps of the Si manufacturing process [1].

## E.2 Silicon Carbide (SiC) Manufacturing Process

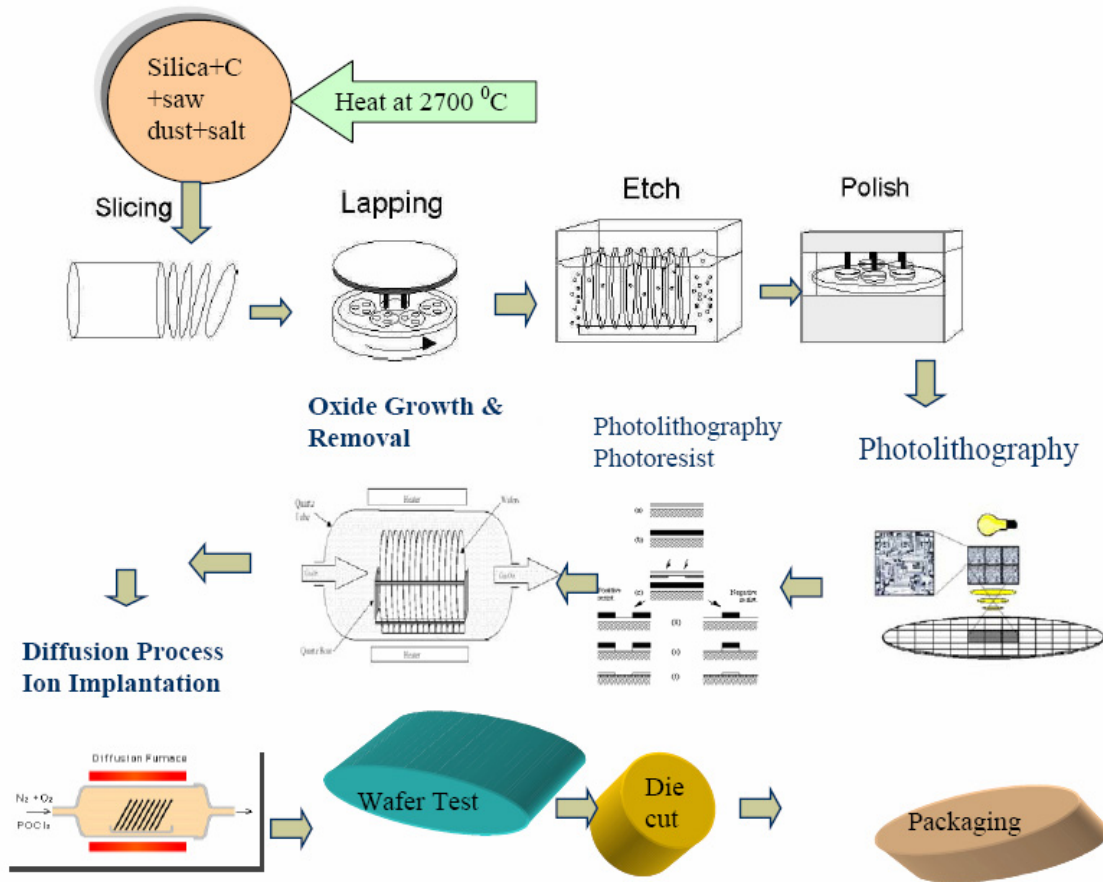


Fig. E.3. The basic steps of SiC manufacturing process [1–3].

The preparation of single crystals needs a high temperature (2400°C), and device processing of SiC needs thermal annealing after ion implantation or CVD processing for doping. It makes the process complex and the wafer expensive. Therefore, SiC processing at low-temperature is desirable (National Institute of Advanced Industrial Science and Technology). The precursors are transported by the hydrogen to a hot zone where the reactions take place [4].

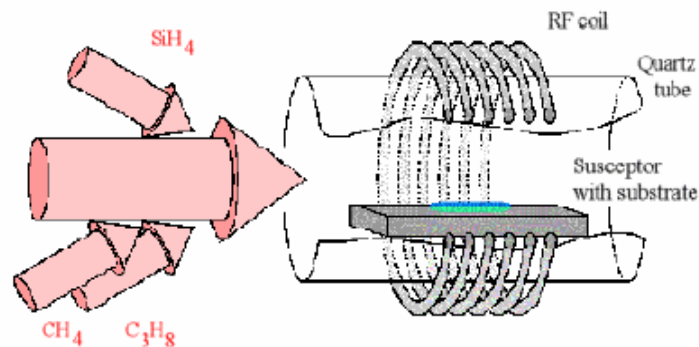


Fig. E.4. The principle of SiC CVD [4].



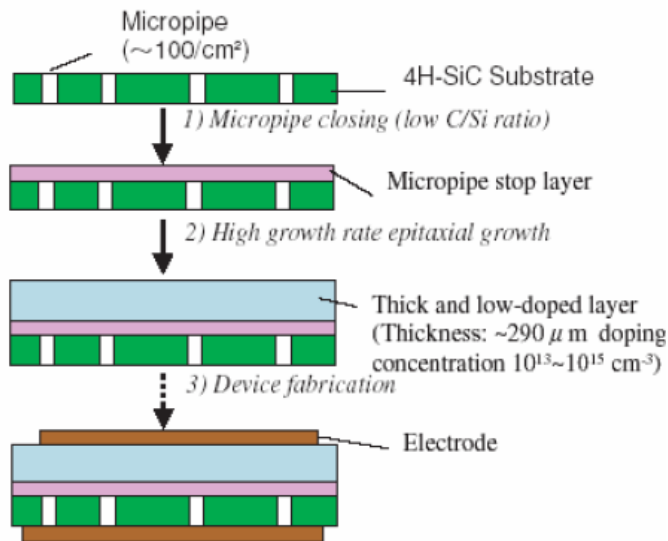


Fig. E.5. Fabrication concept for high-power SiC devices [5].

### E.3 Gallium Nitride (GaN) Manufacturing Process

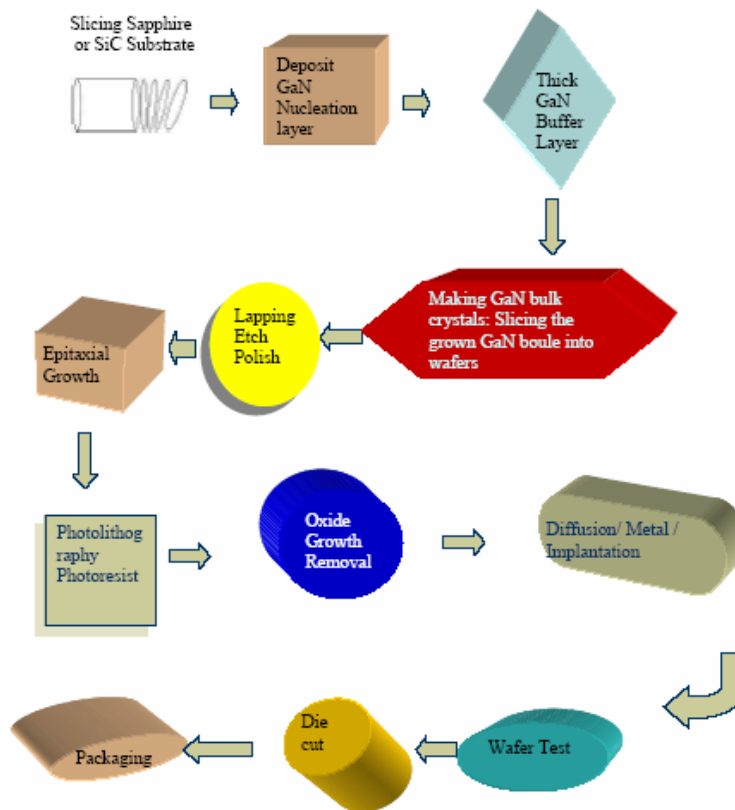


Fig. E.6. The basic steps of GaN manufacturing process [8].

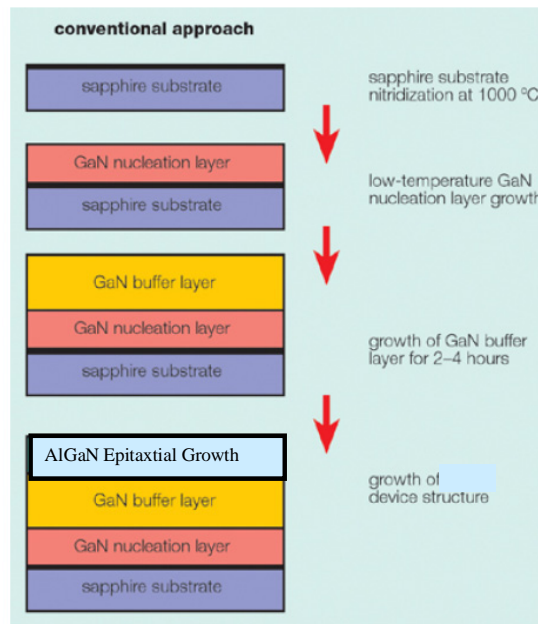


Fig. E.7. GaN-on-sapphire: Conventional growth process (TDI).

#### E.4 Diamond Manufacturing Process

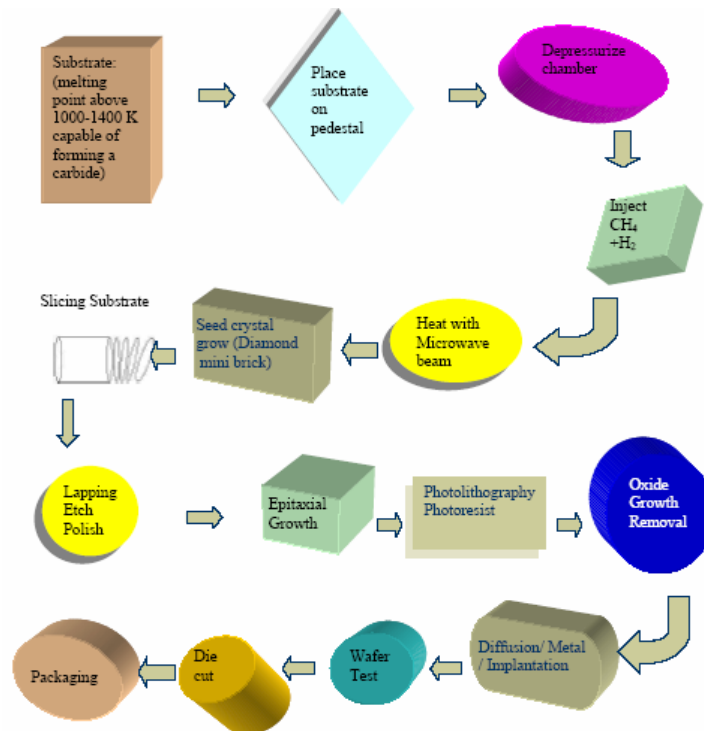


Fig. E.8. The basic steps of Diamond manufacturing process.

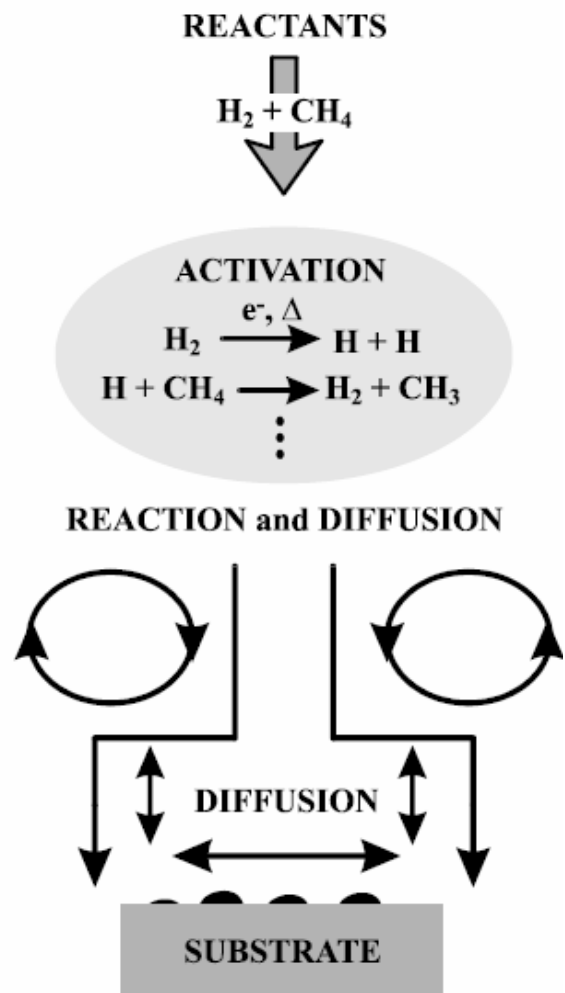


Fig. E.9. Diamond synthesis (CVD process).

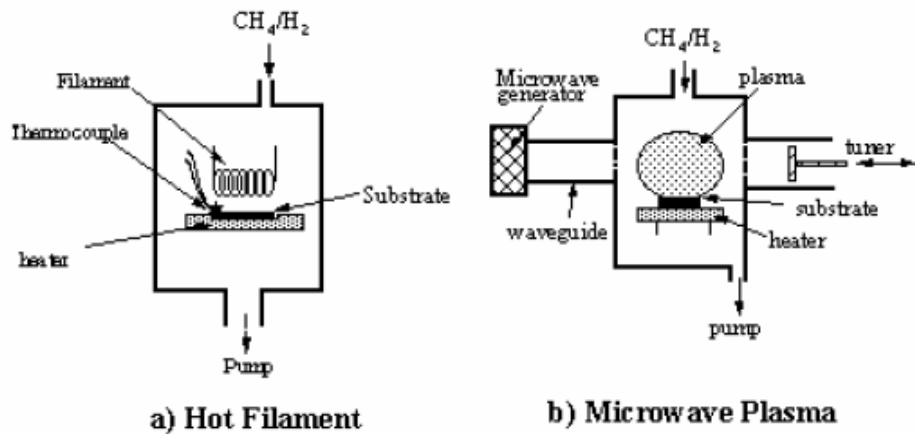


Fig. E.10. Diamond synthesis [6].

## E.5 Microwave Plasma Method

Figure E.11 shows microwave plasma method which is suitable to synthesize high-quality single crystals in larger size although it is not a successful CVD method to synthesize in large area.

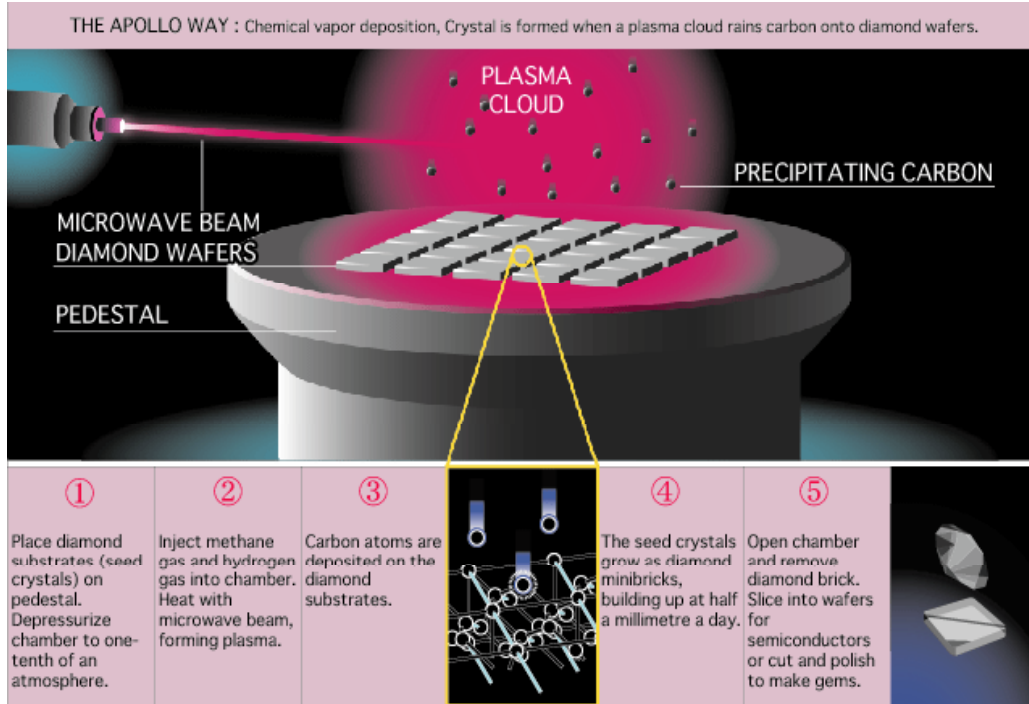


Fig. E.11. CVD synthesis (the Apollo way) (quotations from *WIRED* 2003) [7].

The advances and remaining challenges of high power devices using WBG semiconductors are related with material processing and device fabrications. As in all the transistors, materials include:

- High, controllable p and n type doping
- Low parasitic base/gate access resistance
- Low contact resistance: electron—hole barrier  $>0.1\text{eV}$
- To prevent parasitic base-current: electron lifetime ( $t_e$ )  $\gg$  base-transit time ( $t_b$ )
- Requires indirect-gap base, and /or 'hot-electron' injection
- Limits base/gate width,

In addition there are several technological and processing issues such as: selective etching, process temperature, contact materials isolation, termination, diffusion, ion implantation etc. Many desirable properties are intrinsic to WBG semiconductors, others can only be achieved by 'end-runs' and some still challenge the innovation (ONR). Difficulties with their processing, however, have hampered their progress toward becoming mainstream devices.

## E.6 References

1. Hastings, *The Art of Analog Layout*, Prentice-Hall, 2001.
2. M. Zambuto, *Semiconductor Devices*, McGraw-Hill, 1989.

3. Quirk and Serda, *Semiconductor Manufacturing Technology*, Prentice-Hall, 2001.
4. [http://www.ifm.liu.se/matephys/new\\_page/research/sic/#contents](http://www.ifm.liu.se/matephys/new_page/research/sic/#contents).
5. [http://criepi.denken.or.jp/en/e\\_publication/a2003/03seika46.pdf](http://criepi.denken.or.jp/en/e_publication/a2003/03seika46.pdf).
6. <http://www.tlchm.bris.ac.uk/pt/diamond/image/cvdkits.gif>.
7. [http://www.gaaj-zenhokyo.co.jp/researchroom/kanbetu/2005/kan\\_2005\\_03-01en.html](http://www.gaaj-zenhokyo.co.jp/researchroom/kanbetu/2005/kan_2005_03-01en.html).

## DISTRIBUTION

### Internal

1. D. J. Adams
2. M. A. Brown
3. J. B. Campbell
4. K. P. Gambrell
5. P. W. Garland
6. T. J. King
7. G. Muralidharan
8. B. Ozpineci
9. D. T. Rizy
10. S. Sabau
11. L. M. Tolbert
12. X. Yu
13. H. Zhang
14. W. Zhang
15. Laboratory Records

### External

16. G. Bindewald, U.S. Department of Energy, Office of Electrical Delivery and Energy Reliability, OE-10, 1000 Independence Avenue, SW, FORS EE-2D, Washington, D.C. 20585.
17. D. A. Haught, U.S. Department of Energy, Office of Distributed Energy Program, 1000 Independence Avenue, SW, FORS EE-2D, Washington, D.C. 20585.
18. H. F. Huq, University of Tennessee-Knoxville
19. H. Liu, University of Tennessee-Knoxville
20. P. A. Hoffman, U.S. Department of Energy, Office of Distributed Energy Program, 1000 Independence Avenue, SW, FORS EE-2D, Washington, D.C. 20585.