

**Mo-containing tetrahedral amorphous carbon deposited by  
dual filtered cathodic vacuum arc with selective pulsed bias voltage**

**Nitisak Pasaja<sup>1</sup>, Sakon Sansongsiri<sup>1</sup>, Sawate Intasiri<sup>1,3</sup>, Thiraphat Vilaithong<sup>1</sup>,  
André Anders<sup>2</sup>**

<sup>1</sup> FNRF, Department of Physics, Faculty of Science, Chiang Mai University, Chiang  
Mai 50200, Thailand.

<sup>2</sup> Lawrence Berkeley National Laboratory, University of California, Berkeley,  
California 94720, USA.

<sup>3</sup> Institute of Science and Technology Research and Development, Chiang Mai  
University, Chiang Mai 50200, Thailand.

Revised version of January 24, 2007

Corresponding Author:

Nitisak Pasaja

Fast Neutron Research Facility

Department of Physics, Faculty of Science,

Chiang Mai University, Chiang Mai 50200, Thailand.

Tel. +66 53 943379

Fax. +66 53 222776.

[nitisak@fnrf.science.cmu.ac.th](mailto:nitisak@fnrf.science.cmu.ac.th)

**Mo-containing tetrahedral amorphous carbon deposited by  
dual filtered cathodic vacuum arc with selective pulsed bias voltage**

**Nitisak Pasaja<sup>1</sup>, Sakon Sansongsiri<sup>1</sup>, Sawate Intasiri<sup>1,3</sup>, Thiraphat Vilaithong<sup>1</sup>,  
André Anders<sup>2</sup>**

<sup>1</sup> FNRF, Department of Physics, Faculty of Science, Chiang Mai University, Chiang  
Mai 50200, Thailand.

<sup>2</sup> Lawrence Berkeley National Laboratory, University of California, Berkeley,  
California 94720, USA.

<sup>3</sup> Institute of Science and Technology Research and Development, Chiang Mai  
University, Chiang Mai 50200, Thailand.

**Abstract**

Metal-containing tetrahedral amorphous carbon films were produced by dual filtered cathodic vacuum arc plasma sources operated in sequentially pulsed mode. Negatively pulsed bias was applied to the substrate when carbon plasma was generated, whereas it was absent when the molybdenum plasma was present. Film thickness was measured after deposition by profilometry. Glass slides with silver pads were used as substrates for the measurement of the sheet resistance. The microstructure and composition of the films were characterized by Raman spectroscopy and Rutherford backscattering, respectively. It was found that the electrical resistivity decreases with an increase of the Mo content, which can be ascribed to an increase of the  $sp^2$  content and an increase of the  $sp^2$  cluster size.

Keywords: tetrahedral amorphous carbon, metal doping filtered cathodic vacuum arc; electrical resistivity; profilometry; Raman spectroscopy; Rutherford backscattering.

## 1. Introduction

It was well known that hydrogen-free tetrahedral amorphous carbon (ta-C) films produced by filtered cathodic vacuum arc (FCVA) plasma have superior properties such as very high hardness and elastic modulus, high electrical resistivity, low friction coefficient; however, they also have high intrinsic stress [1]. The  $sp^3$  carbon bond content can reach or even exceed 80%. It has been shown that the properties of amorphous carbon films (both hydrogenated and hydrogen-free) can be greatly modified, and in some respect enhanced, by doping them with metals [2]. The metals used for doping can be classified into two categories, namely, (i) carbide formers such as Ti, W, Mo, Si, Cr and Nb, and (ii) metals that do not form any carbide phase such as Pd and Pt. A good deal of research involving metal containing amorphous carbon focused on improving the tribological and mechanical properties, especially reducing excessive internal stress [3]. Furthermore, metal incorporation in amorphous carbon films can decrease electrical resistivity of the films [4]. Several experiments and techniques were reported about the preparation of conductive metal-containing amorphous carbon films [5,6]. The metals used as dopants to increase electrical conductivity were W, Mo, Cr, Ti, etc.

It is well known that diamond-like carbon films are mostly used as protective coatings. Recently, they have been used as protective coatings of bipolar plates in PEM fuel cells [7]. Bipolar plates are exposed to an operating environment with a PH 2-3 at high temperatures. This will cause corrosion or even dissolution of the metal, resulting in a lowering of the ionic conductivity. In addition, a corrosion layer on the surface of a bipolar plate increases the electrical resistance in the corroded portion and decreases the output of the fuel cell. Because of these problems, bipolar plates are designed with protective coating layers which should be conductive and well adherent

to the base material to protect the substrate from the operating environment. The metal-containing ta-C films have the potential of being applied in coated metallic bipolar plates of PEM fuel cells.

Most of the work on depositing metal-containing amorphous carbon films involved hydrogenated carbon films. They were produced by several methods such as reactive magnetron sputtering using a hydrocarbon gas as part of the gas mixture, and a FCVA operated in hydrocarbon gas environment [3,6,8,9]. However, there are fewer reports on the deposition of metal-containing ta-C films. Chen *et al.* [10] used a FCVA with an Fe/graphite composite cathode with different Fe content, thereby depositing iron-containing amorphous carbon (a-C:Fe) films. He suggested that the percentage of sp<sup>2</sup>-bonded carbon and the size of the sp<sup>2</sup>-bonded cluster increases with an increase in the Fe content.

Monteiro *et al.* [11] used two miniature FCVA plasma sources for depositing tungsten-containing and silicon-containing non-hydrogenated ta-C films. The films are produced by mixing the streams of metal (or silicon) and C ions produced by the two repetitively pulsed vacuum arc plasma sources operating in synchronous pulsed mode. The substrate was pulsed biased while the arc sources were operating. The composition of the films was adjusted by varying the relative duration of the pulse length from each arc plasma source. They concluded that the corresponding decrease in hardness was not very significant as the relatively small W or Si content was increased. Films hardness depended not only on the W content but also on the energy of condensing energy. The films with W content below 20 at.% were amorphous, and films consisted then of mixtures of a-WC and a-C. At higher W content, the films consisted of nanocrystalline WC dispersed in an amorphous carbon matrix. It was

also observed that high pulsed bias leads to high sputtering rates due to the high energy of the multiply charged metal ions.

In this work, we use two filtered cathodic vacuum arc plasma sources, operating sequentially. In contrast to previous work, the negative pulsed bias was only applied to the substrate when the carbon plasma was present. The aim was to deposit ta-C:Mo films whose conductivity is controlled by the applied substrate bias voltage.

## **2. Experimental**

The setup with the two miniature filtered cathodic arc (FCVA) plasma sources is shown in Fig 1. A more detailed description of such “mini-guns” can be found elsewhere [12]. One of the plasma guns had a graphite cathode and the other had a molybdenum cathode such as to deposit Mo-containing tetrahedral amorphous carbon (ta-C:Mo) films. The arc pulse repetition frequency and the ratio of the Mo and C pulses were controlled by LabView<sup>®</sup> software on a personal computer. The thickness of the films were calibrated using thicker films made with 2000 arc pulses and measured with a Dektak IIA profilometer. The pulse duration of the C and the Mo plasma pulses were 5 ms and 1 ms, respectively. The typical arc current was 150 A in the carbon source and 700 A in the Mo source. A negatively pulsed bias voltage was applied to the substrate holder only when the carbon plasma was operating thereby controlling the carbon ion energy. The carbon ions have charge state one and therefore the carbon ion energy is directly associated with the bias voltage. The bias voltage was pulsed with a duty cycle of 40% (8  $\mu$ s “ON” and 12  $\mu$ s “OFF”). The main reason for using pulsed bias is to avoid charge-up of the glass substrate surface: in the bias OFF time, plasma electrons can reach the surface and compensate any excess

positive charge. Furthermore, the surface potential is affected by pulsing of the substrate holder because glass behaves like a dielectric of plate capacitor. When the potential of one side is rapidly changed, the other side follows accordingly due to capacitive coupling.

Two types of samples were used as substrates. One type was a glass slide with sputter-precoated Ag contacts, which allowed us to directly measure the sheet resistance. The ta-C:Mo coated area was a square of 25 mm x 25 mm and therefore the resistance indicated directly the sheet resistance, as measured with a precision digital multimeter. The contact resistance between ta-C:Mo and Ag was neglected with the argument that the sheet resistance is large compared to the contact resistance.

The second type of sample was a Si wafer with a pen mark used to create a step for profilometry, and the non-marked part of the Si wafer was used to investigate the composition and structure of the films. The base pressure of the cryogenically pumped vacuum chamber was about  $2 \times 10^{-4}$  Pa.

Raman spectroscopy was employed to characterize the microstructure of the ta-C:Mo films excited by an Ar<sup>+</sup> laser at 514.5 nm using a Jobin Yvon 64000 system. The Rutherford backscattering spectrometry (RBS) was employed to determine the concentration profiles of Mo and C in the films.

### **3. Results and discussion**

Fig. 2(a) shows that the electrical resistivity of ta-C:Mo films decreases quickly when the ratio of Mo/C pulses is relatively insignificantly increased from 1/20 to 1/15. One may conclude that it is not the amount of Mo that determines the conductivity but rather the changes in the structure of the carbon film that should be considered.

Fig. 2(b) shows the resistivity of ta-C:Mo films at a constant Mo/C pulse ratio of 1/20 at various bias levels, where the bias is applied to carbon plasma only controlling the carbon ion energy. At this low amount of Mo, the films show a behavior similar to pure tetrahedral amorphous carbon. The peak at about 100-200 eV and the lowering of resistivity at higher energies is well-known and documented for ta-C films and attributed to the changes in the  $sp^3/sp^2$  ratio.

RBS analysis was used to determine the concentration profiles of Mo and C in the films. RBS spectra were fitted using the SIMNRA simulation code. Fig. 3 shows two RBS spectra for low and high ratio of Mo/C pulses. As the carbon signal overlaps with that of silicon, the error in the carbon concentration is greater than the error for molybdenum. It can be seen that molybdenum is uniformly distributed within the 10-16 nm thick films. The analysis confirms that the fraction of Mo in the films can be well controlled with the ratio of Mo/C pulses.

Fig. 4 shows Raman spectra of the ta-C:Mo films with different Mo content which were controlled by the ratio of Mo/C pulses. These spectra were fitted to two Gaussian components – the disorder ('D') peak at  $1350\text{ cm}^{-1}$  and the graphite ('G') peak at  $1580\text{ cm}^{-1}$ . It was found that the position of the G peak shifts to lower wave numbers when the Mo content is increased. Ferrari *et al.* [13] interpreted that the down-shift of the G peak is due to the increase in the  $sp^2$  cluster size. Fig. 5 shows that the calculated ratio of the intensity of the D and G peaks,  $I_D/I_G$ , increases with the increase of the Mo content. The same researchers, Ferrari *et al.* [13], concluded that the increase of the  $I_D/I_G$  ratio can be attributed to an increase in the  $sp^2$  content and a corresponding decrease of the  $sp^3$  bonds. The fact that we see very similar tendencies suggests that this interpretation can also be applied to our experiments.

#### **4. Conclusion**

Mo-containing tetrahedral amorphous carbon films (ta-C:Mo) have been deposited using a dual filtered cathodic vacuum arc plasmas system in which the ratio of Mo and carbon plasma pulses can be selected at will. By operating the different plasmas sequentially, the bias was selectively applied to the carbon ions only. Rutherford backscattering showed that the Mo content in the films can be controlled by the ratio of Mo/C plasma pulses. Relatively small amounts of Mo cause a decrease of the electrical resistivity of the films to about  $10^{-2}$   $\Omega$ -cm. The results from Raman spectroscopy show that the electrical resistivity decrease can be attributed to an increase in  $sp^2$  bonding content and the  $sp^2$  cluster size, as other researchers previously suggested for pure ta-C films, rather than the Mo content itself.

#### **Acknowledgements**

This work was supported by the Royal Golden Jubilee (RGJ) Ph.D. Program, the Thailand Research Fund (TRF), Thailand. The authors would like to thank the staff of the Lawrence Berkeley National Laboratory, USA, and of the Fast Neutron Research Facility, Thailand. This work was supported in part by the U.S. Department of Energy under Contract No. DE-AC02-05CH11231.



## References

- [1] J. Robertson, Mater. Sci. Eng. **R37** (2002) 129.
- [2] H. Dimigen, H. Hubsch, R. Memming, Appl. Phys. Lett. **50** (1987) 1056.
- [3] Y.Y. Chang, D.Y. Wang, W. Wu, Thin Solid Films **420** (2002) 241.
- [4] J.Y. Sze, B.K. Tay, D. Sheeja, S.P. Lau, Y.Q. Fu, Daniel H.C. Chua, W.I. Milne, Thin Solid Films **447** (2004) 148.
- [5] H. Rusli, S. F. Yoon, Q. F. Huang, J. Ahn, Q. Zhang, H. Yang, Y. S. Wu, E. J. Teo, T. Osipowicz, and F. Watt, Diamond Rel. Mat. **10** (2001) 132.
- [6] R.K.Y. Fu, Y.F. Mei, L.R. Shen, G.G. Siu, P.K. Chu, Surf. Coat. Technol. **186** (2004) 112.
- [7] V. Mehta and J. S. Cooper, J. Power Sources **114** (2003) 32.
- [8] K. Bewilogua, C.V. Cooper, C. Specht, J. Schroder, R. Wittorf, M. Grischke, Surf. Coat. Technol. **127** (2000) 224.
- [9] C. Corbella, G. Oncins, M.A. Gomez, M.C. Polo, E. Pascual, J. Gacia-Cespedes, J.L. Andujar, E. Bertran, Diamond Rel. Mat. **14** (2005) 1103.
- [10] J.S. Chen, S.P. Lau, G.Y. Chen, Z. Sun, Y.J. Li, B.K. Tay, J.W. Chai, Diamond Relat. Mater. **10** (2001) 2018.
- [11] O.R. Monteiro, M.P. Delplancke-Ogletree, I.G. Brown, Thin Solid Films **342** (1999) 100.
- [12] A. Anders, R.A. MacGill, T.A. McVeigh, Rev. Sci. Instrum. **70** (1999) 4532.
- [13] A.C. Ferrari, J. Robertson, Phys. Rev. B **61** (2000) 14095.

### **Figure captions**

Fig.1 Setup of the dual filtered cathodic vacuum arc plasma sources with selective pulsed bias voltage applied to carbon only.

Fig.2 (a) Electrical resistivity of ta-C:Mo films as a function of the Mo and C plasma pulses; (b) Electrical resistivity of the ta-C:Mo films as a function of the pulsed bias applied to carbon only, at a fixed ratio of 1/20 for Mo/C plasma pulsed.

Fig.3 RBS spectra acquired from ta-C:Mo films deposited using a (a) 1/2 and (b) 1/15 ratio of Mo/C arc pulses with a pulsed substrate bias voltage of  $-250$  V for carbon only.

Fig.4 Raman spectra obtained for ta-C:Mo on Si at various ratios of the Mo/C arc pulses.

Fig.5 The ratio of intensity of the D and G peaks as a function of the ratio of Mo/C arc plasma pulses.

Figures

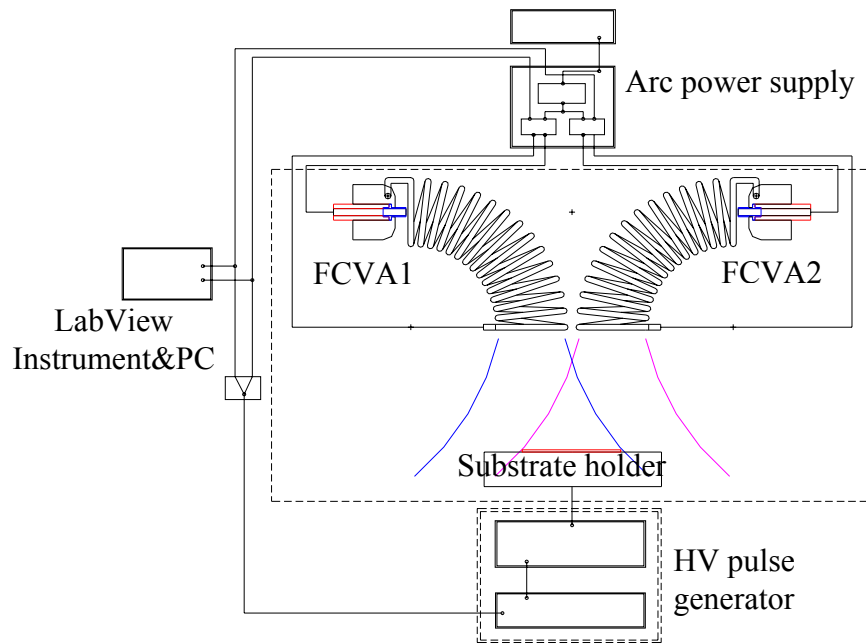

Fig. 1

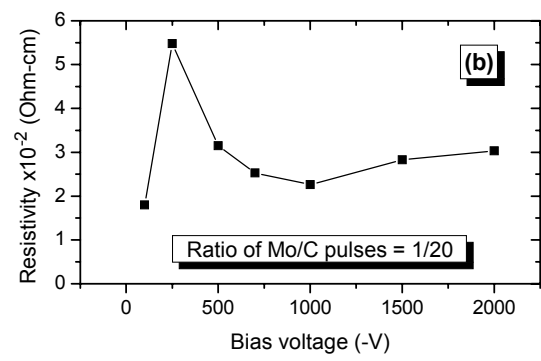
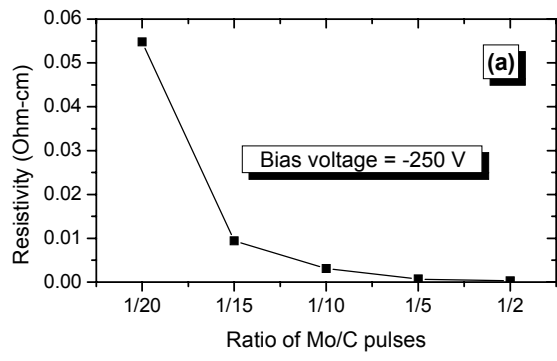

Fig. 2

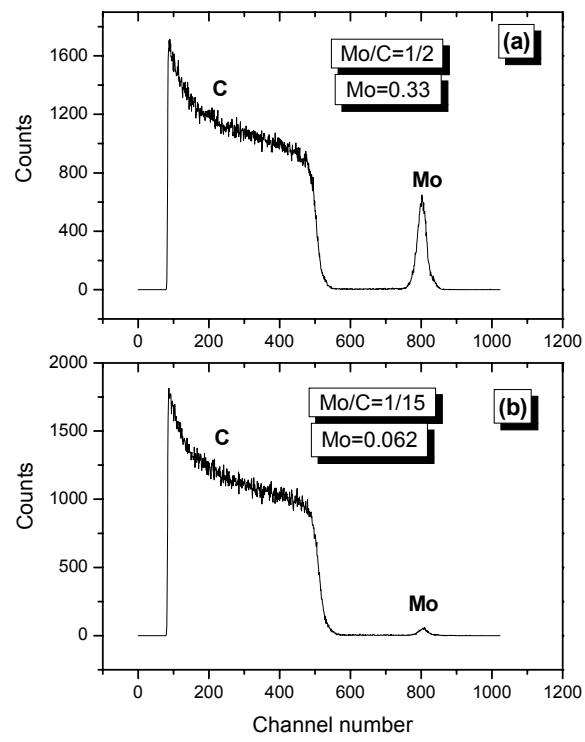

Fig. 3

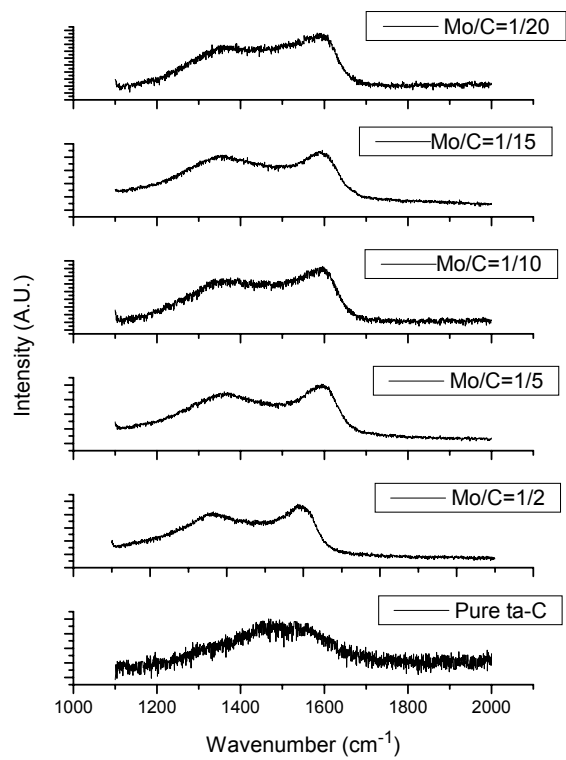

Fig. 4

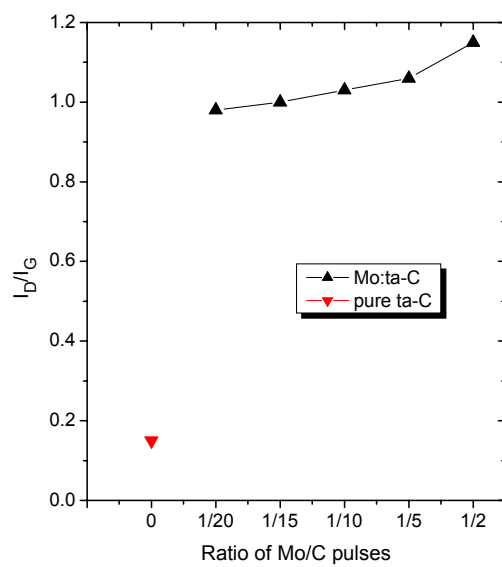

Fig. 5