

**Garrett Electric Boosting Systems (EBS) Program  
Federal Grant DE-FC05-00OR22809**

**Final Report**

Steve Arnold  
Craig Balis  
Pierre Barthelet  
Etienne Poix  
Tariq Samad  
Greg Hampson  
S.M. Shahed

Honeywell Turbo Technologies

**June 22, 2005**

## Executive Summary

Turbo diesel engine use in passenger cars in Europe has resulted in 30-50% improvement in fuel economy. Diesel engine application is particularly suitable for US because of vehicle size and duty cycle patterns. Adopting this technology for use in the US presents two issues ... emissions and driveability. Emissions reduction technology is being well addressed with advanced turbocharging, fuel injection and catalytic aftertreatment systems. One way to address driveability is to eliminate turbo lag and increase low speed torque. Electrically assisted turbocharging concepts incorporated in e-Turbo™ designs do both.

The purpose of this project is to design and develop an electrically assisted turbocharger, e-Turbo™, for diesel engine use in the US. In this report, early design and development of electrical assist technology is described together with issues and potential benefits. In this early phase a mathematical model was developed and verified. The model was used in a sensitivity study. The results of the sensitivity study together with the design and test of first generation hardware was fed into second generation designs. In order to fully realize the benefits of electrical assist technology it was necessary to expand the scope of work to include technology on the compressor side as well as electronic controls concepts. The results of the expanded scope of work are also reported here.

In the first instance, designs and hardware were developed for a small engine to quantify and demonstrate benefits. The turbo size was such that it could be applied in a bi-turbo configuration to an SUV sized V engine. Mathematical simulation was used to quantify the possible benefits in an SUV application. It is shown that low speed torque can be increased to get the high performance expected in US, automatic transmission vehicles. It is also shown that e-Turbo™ can be used to generate modest amounts of electrical power and supplement the alternator under most load-speed conditions. It is shown that a single (large) e-Turbo™ consumes slightly less electrical power for the same steady state torque shaping than a bi-Turbo configuration. However, the transient response of a bi-Turbo configuration is slightly better.

It was shown that in order to make full use of additional capabilities of e-Turbo™ wide compressor flow range is required. Variable geometry compressor (VGC) technology developed under a separate project was evaluated for incorporation into e-Turbo™ designs. It was shown that the combination of these two technologies enables very high torque at low engine speeds. Designs and hardware combining VGC and e-Turbo™ are to be developed in a future project.

There is concern about high power demands (even though momentary) of e-Turbo™. Reducing the inertia of the turbocharger can reduce power demand and increase battery life. Low inertia turbocharger technology called IBT developed under a separate project was evaluated for synergy with e-Turbo™ designs. It was concluded that inertial reduction provided by IBT is very beneficial for e-Turbo™. Designs and hardware combining IBT and e-Turbo™ are to be developed in a future project.

e-Turbo™ provides several additional flexibilities including exhaust gas recirculation (EGR) for emissions reduction with minimum fuel economy penalty and exhaust temperature control for aftertreatment. In integrated multi-parameter control system is needed to realize the full potential of e-Turbo™ performance. Honeywell expertise in process control systems involving hundreds of sensors and actuators was applied to demonstrate the potential benefits of multi-parameter, model based control systems.

## Table of Contents

- 1.0 Introduction
- 2.0 Base Electric Assist Technology
  - 2.1 Design & Test of 1<sup>st</sup> Generation Electrical Assist Technology
  - 2.2 Design and Test 2<sup>nd</sup> Generation Prototype
  - 2.3 Evaluate and Confirm Benefits of e-Turbo™
  - 2.4 Development of 3<sup>rd</sup> Generation Prototype
  - 2.5 Simulation of e-Turbo™ Application to 4.0 Liter Engine
- 3.0 Integrated Control System
  - 3.1 Simulate & Demonstrate Benefits of Advanced Sensing & Control
  - 3.2 Integrated e-Turbo™ and Battery Charge Management
  - 3.3 Integrated e-Turbo™ and Exhaust After-treatment
- 4.0 Incorporation of Low Inertia Turbocharger Technology to Minimize Power Demand
- 5.0 Incorporation of Variable Geometry Compressor Technology to Take Advantage of e-Turbo™
- 6.0 Summary and Conclusions

## List of Illustrations

1. Diesel engine progress due to turbocharging and other technologies such as fuel injection system, charge air cooling
2. The effect of intake charge pressure on power density and smoke
3. The effect of charge density on NO<sub>x</sub> and fuel consumption
4. European turbo diesel vs gasoline engine fuel economy
5. Low speed torque deficit of a turbocharged engine compared with a larger displacement non-turbocharged engine under steady state conditions
6. Turbo lag under transient conditions due to "bootstrapping" effect and turbo inertia
7. Cross-sectional sketch of e-Turbo™ showing motor/generator on the same shaft as turbomachinery, extended in length
8. Illustrative simulation results showing torque shaping of diesel engines at low speeds using electrical assist
9. Illustrative simulation results showing torque shaping of gasoline engines at low speeds using electrical assist
10. Bearing system selection to resolve shaft motion issue with e-Turbo™
11. Simulated brake specific fuel consumption (BSFC) improvement with electrical power generation
12. Model calculations compared against engine data under steady state conditions for a range of speeds and loads.
13. Model calculations compared against data under transient conditions
14. Simulated sensitivity analysis showing that a smaller engine responds much more to a given electrical power supply
15. Simulated sensitivity analysis showing that the rate of improvement with electrical power supply increase is much better for smaller engine displacements
16. Fuel consumption of 2002 model year production gasoline engine powered vehicles over the New European Driving Cycle (NEDC) showing that turbocharged downsized engines give better fuel economy for the same power
17. Data from European production vehicles compiled by Ricardo showing that for the same vehicle a downsized diesel engine with improved turbocharging gives better fuel economy over the New European Driving Cycle.

18. e-Turbo™ ON/OFF recording under road load conditions
19. Statistical analysis of e-Turbo™ duty cycle under representative road conditions
20. Finite Element Analysis of heat transfer in an e-Turbo™
21. Rotor and stator temperature of e-Turbo™ under severe duty cycle conditions
22. Photograph of second generation e-Turbo™ hardware
23. Transient response of a diesel engine with e-Turbo™ under cold and hot conditions
24. Transient response of e-Turbo™ diesel engine powered passenger vehicle in second gear
25. Transient response of e-Turbo™ diesel engine powered passenger vehicle in third gear
26. Simulated response of a diesel engine powered vehicle with downsized engine with and without electrically assisted boost
27. Boost response of a baseline VNT diesel engine and e-Turbo™ diesel engine
28. Boost response of a high performance diesel engine, VNT diesel engine and e-Turbo™ diesel engine illustrating torque shaping potential
29. Electrical power generation and fuel economy improvement with e-Turbo™
30. Illustrating that electrical power generation with e-Turbo™ is not possible under low load-speed conditions and showing 0.5 to 4.0% improvement in fuel economy over the load-speed range
31. Illustrating turbine efficiency drop-off with supplementary electrical power supply
32. Simulated baseline (no e-Turbo) torque characteristics of a 4.0 liter diesel engine equipped with bi-turbo and single turbo configurations
33. Simulated transient response characteristics of a 4.0 liter diesel engine at 800, 1000 and 1250 engine rpm in a bi-turbo configuration
34. Simulated transient response characteristics of a 4.0 liter diesel engine at 800, 1000 and 1250 Engine rpm in a single turbo configuration
35. Simulated low speed torque shaping with e-Turbo, 4.0 liter diesel engine in a bi-turbo configuration, with and without recirculation valve. Baseline bi-turbo torque curve is also shown for comparison
36. Simulated low speed torque shaping with e-Turbo. Single turbo configuration with and without recirculation valve. Baseline and bi-turbo torque curves are also shown for ready comparison

37. Comparison of simulated torque shaping with bi-turbo and single turbo BOTH with electric assist compared to baseline
38. Transient response of 4.0 liter diesel engine with and without electrical assist in a bi-turbo configuration at 800 rpm
39. Simulated transient response of 4.0 liter diesel engine with and without electrical assist in a bi-turbo configuration at 1200 rpm
40. Simulated transient response measured as torque increase one second after step increase in fueling. Single and bi-Turbo configurations with and without electrical power are compared
41. Illustrative example of multi-parameter control with model based control system for overall system optimization
42. Sensing and control architecture for e-Turbo™
43. Illustrative results of multi-parameter integrated control without the use of NOx sensor showing that actual NOx is considerably higher than NOx set point
44. Illustrative results of multi-parameter integrated control with the use of NOx sensor showing that NOx actual is much closer to NOx setpoint
45. Illustrative results of battery state of charge with e-Turbo™
46. Pressure drop (kPa) and DPF surface temperature (K) during self-ignition regeneration event as simulated with model in Matlab due to step change in engine exhaust temperature at 60 seconds - shows self ignition and burn-out as soot level drops during regeneration burn off (not shown)
47. Step changes in VNT, EGR, and e-Turbo power from left to right and resulting O2 and engine turbine out temperature below each. Shows potential to control O2 and temperature into DPF and that it may be possible to light-off DPF without burning additional fuel
48. Possible exhaust temperature increase with 250 W of power generation with e-Turbo™ under various load-speed conditions
49. IBT low inertia turbo rotating components compared to conventional turbocharger components of the same flow capabilities
50. Wrapped inlet configuration of IBT low inertia turbocharger
51. Dual inlet configuration of IBT low inertia turbocharger
52. Concept design of movable vanes in the diffuser of compressor
53. Photograph of variable geometry compressor hardware
54. Flow range increase with variable geometry compressor

## 1.0 Introduction:

Air supply is critical to internal combustion engines. Gasoline engines use 9000 liters of air for every liter of fuel burnt while diesel engines, on the average use as much as 20,000 liters of air per liter of fuel.

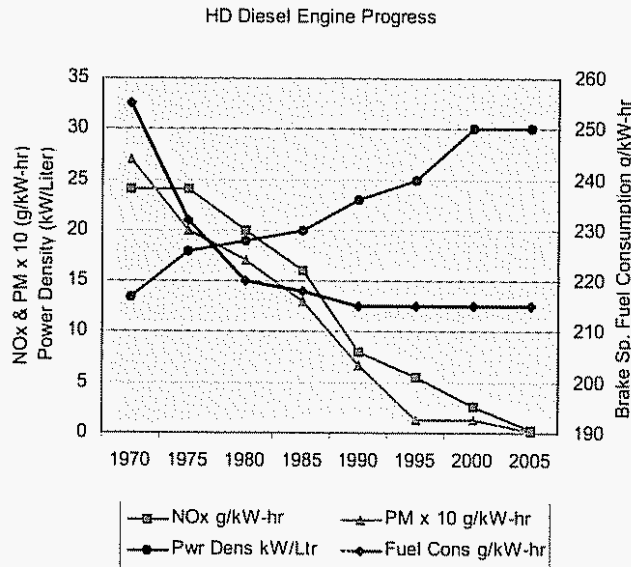

Figure 1: Diesel engine progress due to turbocharging and other technologies such as fuel injection system, charge air cooling etc.

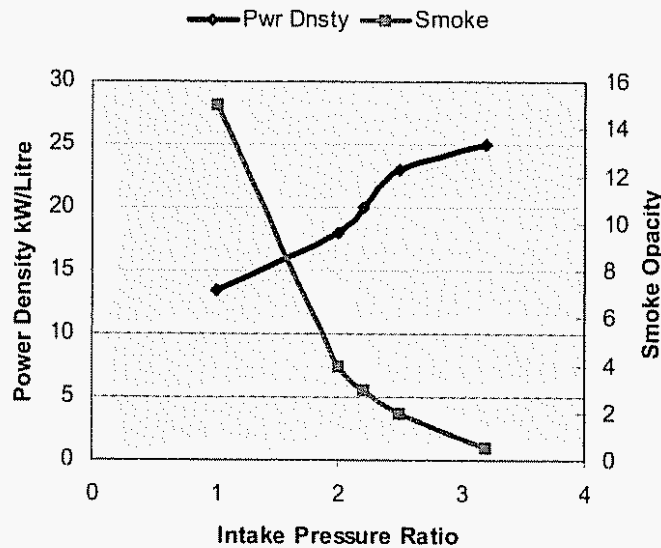

Figure 2: The effect of intake charge pressure on power density and smoke



Figure 1 shows the historical progress made by heavy-duty diesel engines (1). A large measure of this progress is due to the supply of high density, cooled charge air using turbocharging and charge cooling technology. Increased air density reduces particulate emissions (Figure 2) and reduced charge temperature reduces NOx emissions while simultaneously improving fuel economy (Figure 3) (2). Increased air density also enables heat release rate optimization to get the best trade-off between NOx and fuel economy.

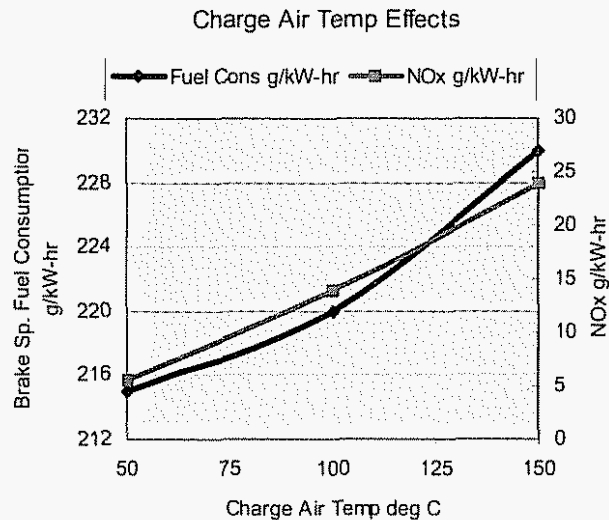

Figure 3: The effect of charge density on NOx and fuel consumption

European OEMs have further developed and applied these technologies to passenger car diesel engines resulting in fuel economy improvements on the order of 30-50% for the same class of vehicle (3). Figure 4 shows data for production passenger vehicles for model year 2000. The US fleet average data are taken from the National Academy of Sciences report on CAFE regulations. The test data are over the EPA equivalent CAFE test cycle. These are converted to the equivalent numbers for the New European Driving Cycle (NEDC) using conversion factors developed by the Argonne National Lab and reported in the Transportation Energy Data book published by the Oak Ridge National Lab. Turbo diesel engine data are from production vehicles available in Europe and reported in an SAE publication (3). If the same technology and same dieselization were to be used in the US, oil imports "equivalent to those from Saudi Arabia" could be avoided (4).

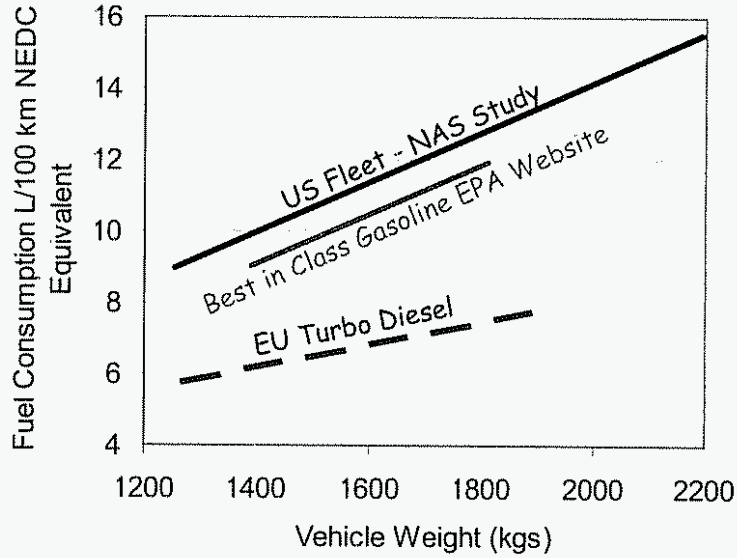

Figure 4: European turbo diesel vs gasoline engine fuel economy

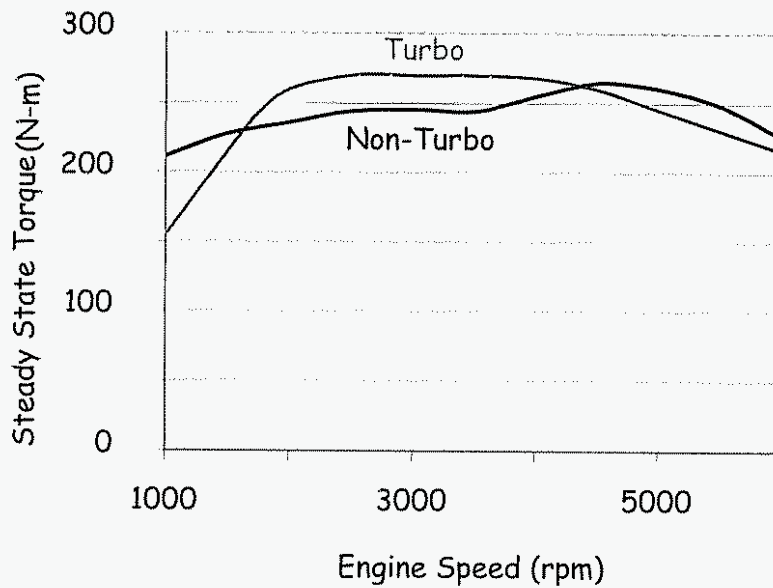

Figure 5: Low speed torque deficit of a turbocharged engine compared with a larger displacement non-turbocharged engine under steady state conditions

Figures 5 and 6 show one potential problem in the widespread application of this technology in the US. Figure 5 shows steady state torque of a turbocharged engine compared to that of a non-turbocharged engine of much larger displacement. The smaller, turbocharged engine is

able to develop torque equivalent to a larger engine at high speeds because the turbocharger has enough energy/power to supply the necessary amount of air. However, at low speeds, when starting from a stop light or from the curb, there is not enough exhaust energy to power up the turbocharger. Hence there is a "torque deficit" which shows up as momentary hesitation in the vehicle. Figure 6 shows a related phenomenon resulting in the same effect. It shows that at zero time, when the fuel pedal is depressed, fuel supply can respond instantaneously. However, the turbocharger takes time to respond because it relies on a bootstrapping effect of increasing exhaust energy and air flow. This response time is further affected by turbocharger inertia and shows up as momentary hesitation in vehicle response. This effect is largely mitigated in Europe due to the use of variable geometry turbocharging technology and manual transmissions. However, in the US, automatic transmissions are more in demand and such hesitation, commonly termed as "turbo-lag" is not acceptable to the consumer.

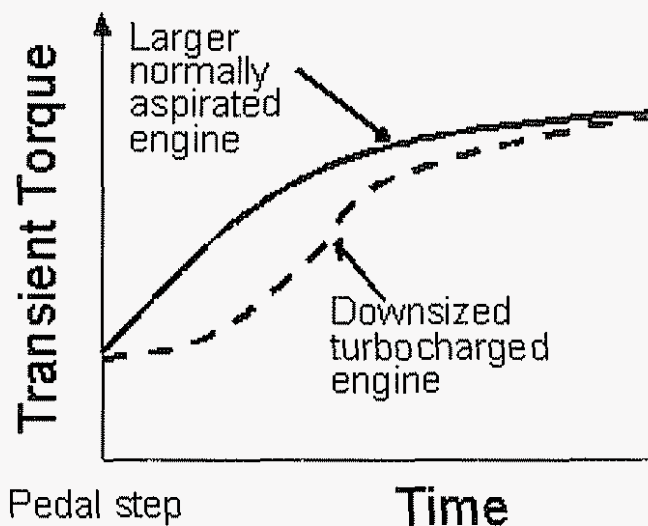

Figure 6: Turbo lag under transient conditions due to "bootstrapping" effect and turbo inertia

Therefore, in order to increase the acceptance of diesel engines in the US, and to take advantage of the potential 30-50% improvement in fuel economy, turbocharging technology has to be improved to get rid of turbo-lag and low speed torque deficit. This can provide low speed torque shaping that adds to the driving experience. Further, the size and duty cycle of

engines in the US are considerably different from those in Europe. Therefore, turbocharging technology has to be adapted specifically for US applications.

One very promising technology to address these needs is electrically assisted turbocharging or e-Turbo™. The basic concept of this technology is shown in Figure 7. An electric motor/generator is incorporated on the same shaft as the turbocharger (5). At low engine speeds, when the turbocharger needs supplementary power to overcome the torque deficit and turbo lag referred to above, electrical power is momentarily supplied to the turbocharger to speed it up. At high engine speed and power, when there is excess exhaust energy, power is generated by the turbocharger-mounted generator and can be used to supplement the alternator. Early simulation done with diesel and gasoline engines shows the potential of torque shaping and fast response (6) as illustrated in Figures 8 & 9 below.

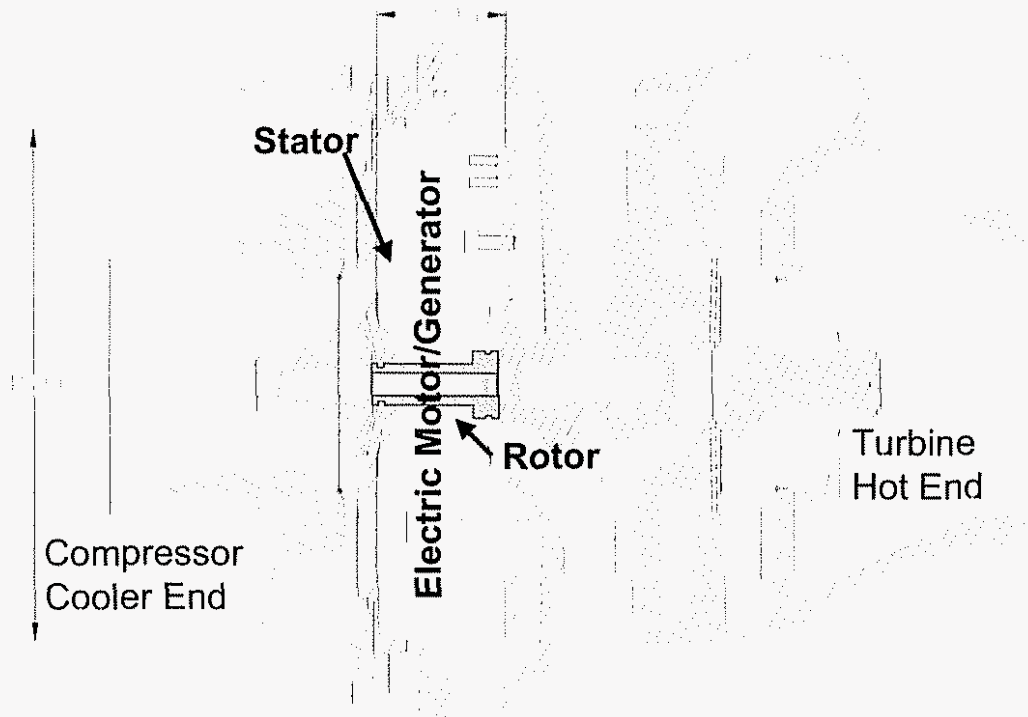

Figure 7: Cross-sectional sketch of e-Turbo™ showing motor/generator on the same shaft as turbomachinery, extended in length

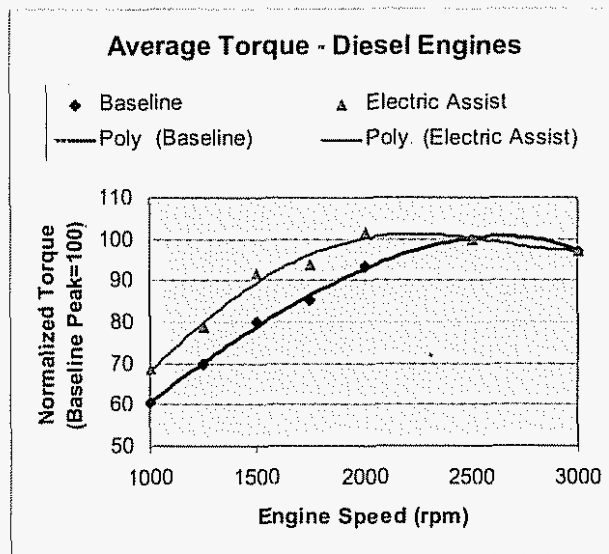

Figure 8: Illustrative simulation results showing torque shaping of diesel engines at low speeds using electrical assist

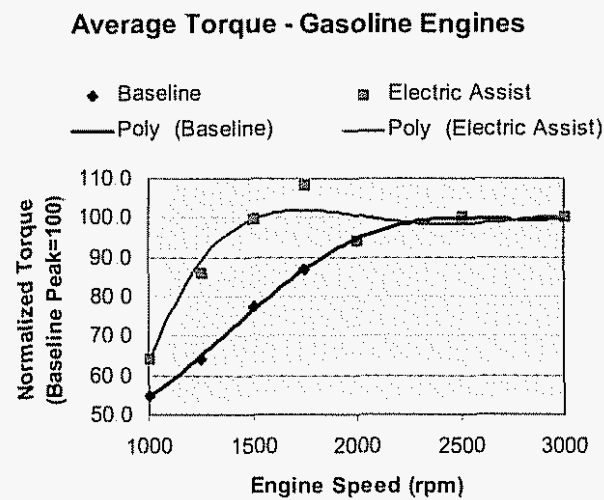

Figure 9: Illustrative simulation results showing torque shaping of gasoline engines at low speeds using electrical assist

Electrical assist increases the flexibility of operating regimes of a turbocharger. This flexibility necessitates the adaptation of several technologies in order to take full benefit as measured by improved driveability, fuel economy and emissions. One, there is a need to develop a comprehensive control system that works in conjunction with other controls

on the engine and maintains the state of the charge of the battery. Two, there is a need to increase the flow range of the compressor without sending it into surge, a destructive flow instability induced under some operating conditions. Finally, there is a need to reduce electrical power demand. With a 12V battery system, even at a modest 2 kW power supply, current levels are of the order of 167 Amps. This represents a huge demand on power electronics as well as on batteries. A high voltage stand-alone battery can improve the situation, however, a low inertia turbocharger is also required.

The purpose of the project is to develop an e-Turbo™, for SUV and light truck class of passenger vehicles. The scope of work for 2004 includes four technology areas.

1. Base electric assist technology - motor/generator, power supply, rotor stability and temperature control.
2. Integrated control systems for power, VNT, EGR, and battery in an e-Turbo™ system.
3. Incorporation of low inertia turbocharger technology to minimize power demand.
4. Incorporation of variable geometry compressor technology to take full advantage of e-Turbo™.

## 2.0 Base Electric Assist Technology:

The purpose of this task is to develop electrical machinery for e-Turbo™ applications specifically suited for US applications. The first step was the development of e-Turbo™ for a 2 liter engine, confirm performance and then apply it to each bank of an SUV sized 4-6 liter engine. After successful demonstration of concept and performance, a specific design for SUV sized diesel engines can be developed. Early phases of design and development concentrated on permanent magnet (PM) technology and evaluated switch reluctance motor (SRM) and induction motor (IM) technology. After some work with PM technology it was concluded that it would be best to develop IM technology for generation 2 prototypes. In addition, simulation models were built and verified. They were used in a sensitivity study to set goals for second generation designs. Results of this

early work are reported briefly in Section 2.1 and form the basis of the expanded scope of work in 2004. Deliverables for 2004 are.

- Design and test 2<sup>nd</sup> generation prototype on bench, engine, and vehicle.
- Evaluate & confirm benefits - torque, fuel economy, power generation.
- Begin development of a 3<sup>rd</sup> generation improved prototype design
- Begin simulation analysis of e-Turbo™ for 4-6 liter engine.

The results against each of these deliverables are reported in the sections below.

## 2.1 Design and Test of Gen 1 Electrical Assist Technology:

Turbochargers are compact air-flow machines because they rotate at a very high speed. For relatively small engines (~1-2 liter) turbocharger speeds can be as high as 250,000 rpm. For larger engines (~4-6 liter) speeds of 120,000 rpm are not uncommon. Balancing of turbochargers accounting for all the mechanical, aerodynamic, hydrodynamic and vibratory forces is very demanding. Improper balancing can result in noise and/or mechanical damage and destruction. Two major new parameters are introduced with the e-Turbo™ ... (a) the length of the shaft is increased, increasing the cantilever effect of the shaft on the bearing system (see Figure 7) and (b) electro-magnetic forces are introduced. Both of these effects have to be accounted for in balancing the e-Turbo™.

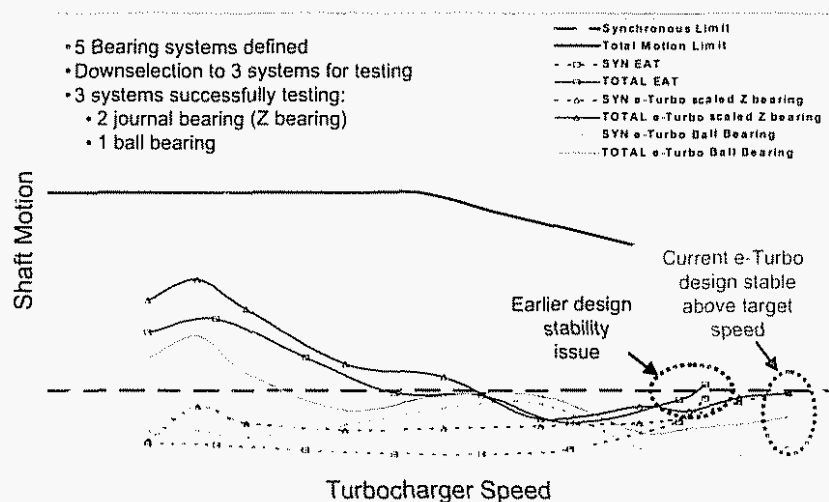

Figure 10: Bearing system selection to resolve shaft motion issue with e-Turbo™

One measure of balancing is to check the extreme positions of shaft motion under rotation. This motion has to be kept within specified limits at high turbo speeds and the curvature of motion vs. speed should be asymptotic rather than increasing. Bearing design improvements are needed to keep shaft motion within specifications. Five existing bearing designs were tested and one that met specifications was selected for use in the 2<sup>nd</sup> generation design as shown in Figure 10.

In Figure 10 it is noted that early designs showed an instability issue - a sharply rising slope of shaft motion vs speed at the high speed end. During these early phases of development, permanent magnet, switch reluctance motor and induction motor technologies were evaluated. Considerable effort was spent on permanent magnet technology and prototype testing before concluding that shaft stability issues could be better addressed with induction motor technology together with improved bearing designs as shown in Figure 10.

In addition to shaft motion, permanent magnet technology tends to be more sensitive to temperature excursions. At high temperatures, permanent magnets can get de-magnetized. During design and test of Gen 1, this issue was identified and addressed in Gen 2 designs as described in Section 2.2 below.

The benefits of electrical assist technology were also estimated by simulation work during this phase of the project. Figures 8 and 9 already shown above give some of the results. They show that low speed torque of both diesel and gasoline engines can be increased considerably, improving the response of the vehicle. The expanded scope of work includes results of engine as well as vehicle performance simulation.

A further potential benefit of electrical assist technology was investigated during this early phase of the project. Traditionally, turbochargers are "wastegated". If a turbocharger is designed to be large enough to smoothly flow the exhaust at rated load and speed conditions, then its size is likely to be large. Such a turbocharger is likely to have a sluggish response. It is more desirable to design and use a smaller turbocharger with a faster response. In order to handle high flows at high load and speed conditions, a "wastegate" valve is opened to bypass the



turbocharger turbine, without challenging its flow handling capability. As is implied in the name, a “wastegate” wastes otherwise useful exhaust energy. Figure 11 is a simulated estimate of possible electrical power generation as a substitute for wastegating. It is shown that for a 2.5 liter engine as much as 6-9% improvement in brake specific fuel consumption is possible if wastegate flow were utilized fully.

### BSFC Improvement with Electrical Assist - 2.5 Liter Engine

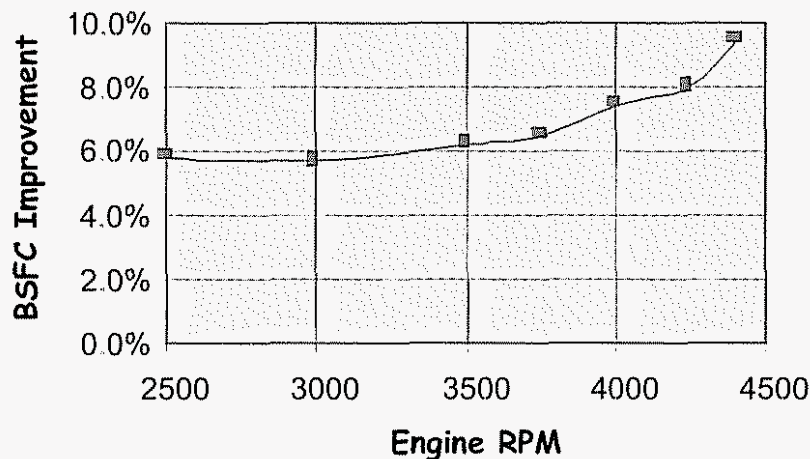

Figure 11: Simulated brake specific fuel consumption (BSFC) improvement with electrical power generation

Results of Figure 11 gave a very promising early estimate of possible fuel economy benefits. However, it should be remembered that passenger cars do not frequently operate at full load and full speed, or even at high loads at part speeds. Therefore, potential fuel economy benefits have to be tempered with considerations of duty cycle. In addition, the simulation in Figure 11 does not take into account the limitations of electrical machinery ... its power rating and temperature considerations. This work was done as a part of the expanded scope and is reported in Section 2.3.

As a necessary part of the development process a computer simulation model of an engine/vehicle equipped with electrically assisted turbocharging was developed. Figures 12 and 13 show the validation of the model under steady state and transient conditions.

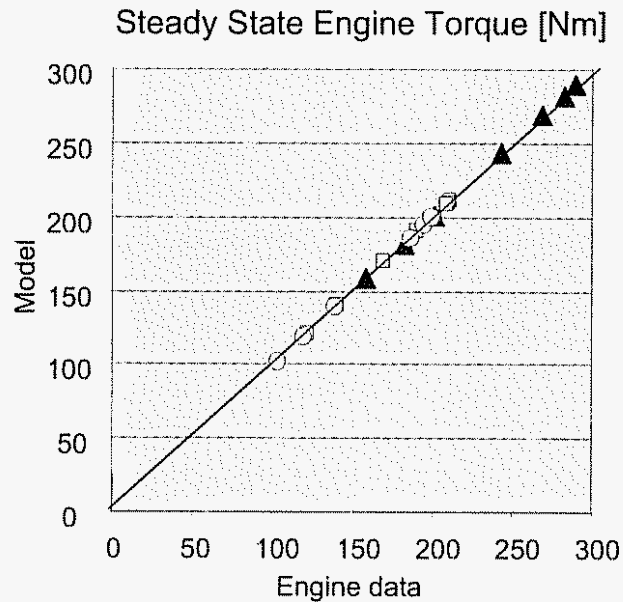

Figure 12: Model calculations compared against engine data under steady state conditions for a range of speeds and loads.

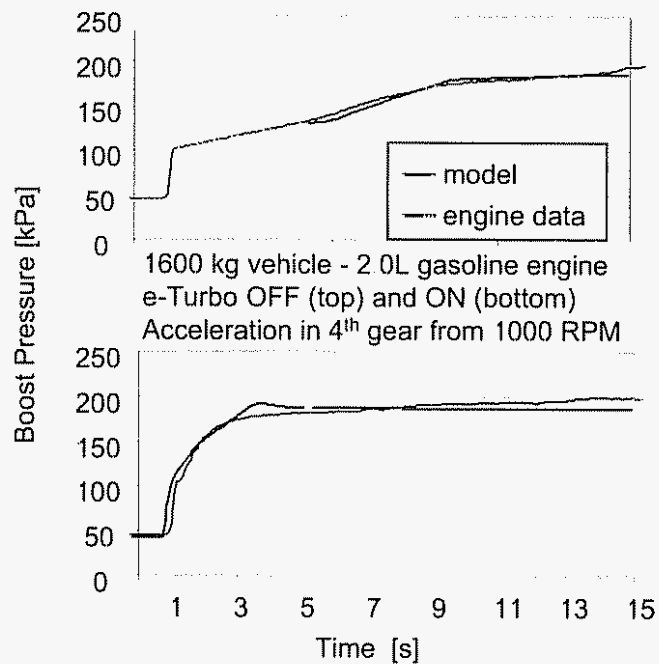

Figure 13: Model calculations compared against data under transient conditions

The model was used to conduct sensitivity analyses to optimize the combination of engine size, electrical power requirements and boost

response. Such sensitivity analysis was used to set targets for the design of generation 2 machines and controls. Representative results are shown in Figures 14 and 15. In both sets of calculations the engine is given a step increase in load (and fuelling). Simultaneously, a linear ramp up of engine speed is given in order to simulate on road performance of an engine/vehicle combination. This is because turbo response is very sensitive to engine speed (flow rate) and in actual on-road conditions engine speed increases alongside load and fueling increase.

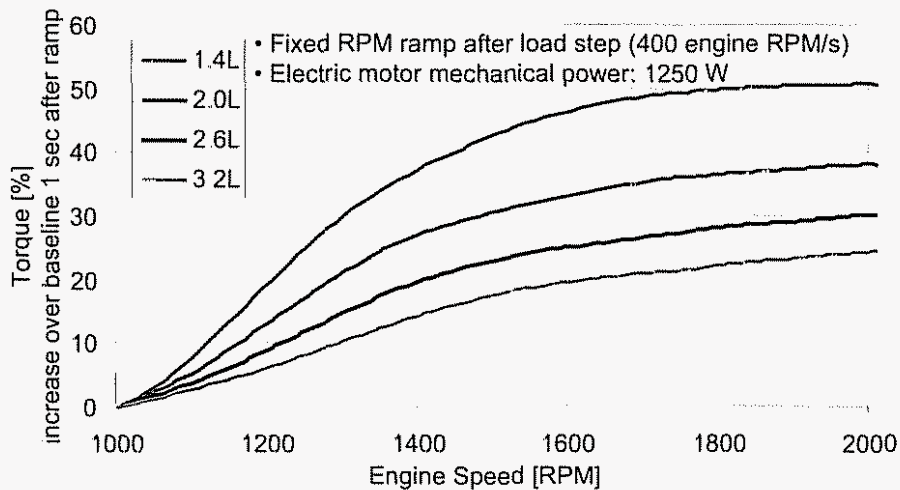

Figure 14: Simulated sensitivity analysis showing that a smaller engine responds much more to a given electrical power supply

It can be seen from the results of Figure 14 that for a given power supply, a smaller engine responds much more in terms of torque increase. The cost of electrical machinery and power electronics increases exponentially with the increase in current (power) level. Keeping electrical power consumption to a minimum is highly desirable from the cost and fuel economy points of view as well as the size of electrical machinery.

Figure 15 illustrates that at a fixed speed, the relative torque increase available at increasing power shows diminishing returns for larger engines. Thus, an increase in power supply for a small engine shows big effects in torque increase. However, for large engines not only is the torque increase less, but also the rate of increase with increasing power supply is not so desirable.

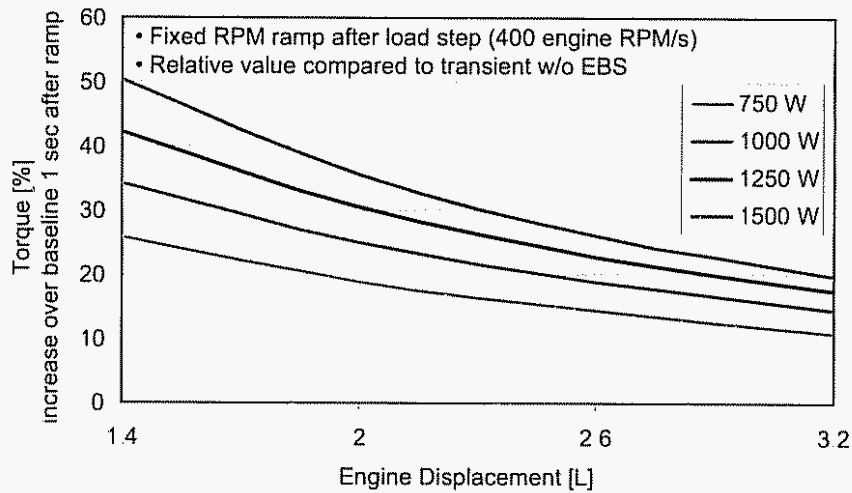

Figure 15: Simulated sensitivity analysis showing that the rate of improvement with electrical power supply increase is much better for smaller engine displacements

It is also fortunate that the benefits of engine downsizing are very strong in both gasoline and diesel engines as shown in Figures 16 and 17.

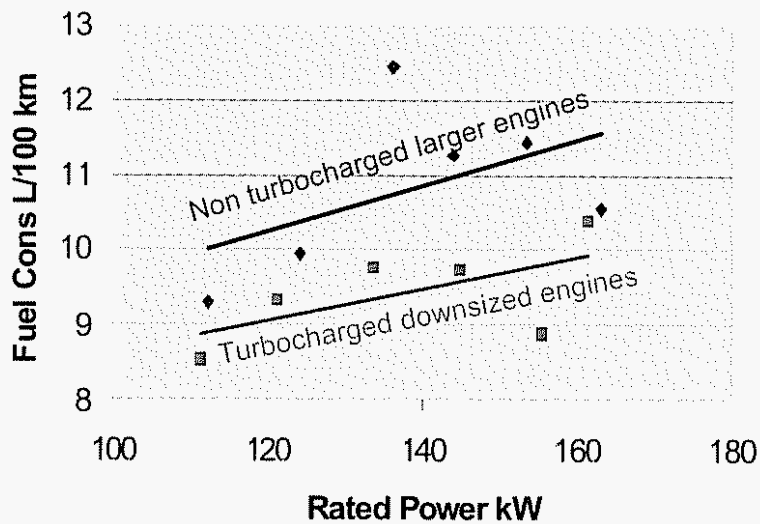

Figure 16: Fuel consumption of 2002 model year production gasoline engine powered vehicles over the New European Driving Cycle (NEDC) showing that turbocharged downsized engines give better fuel economy for the same power

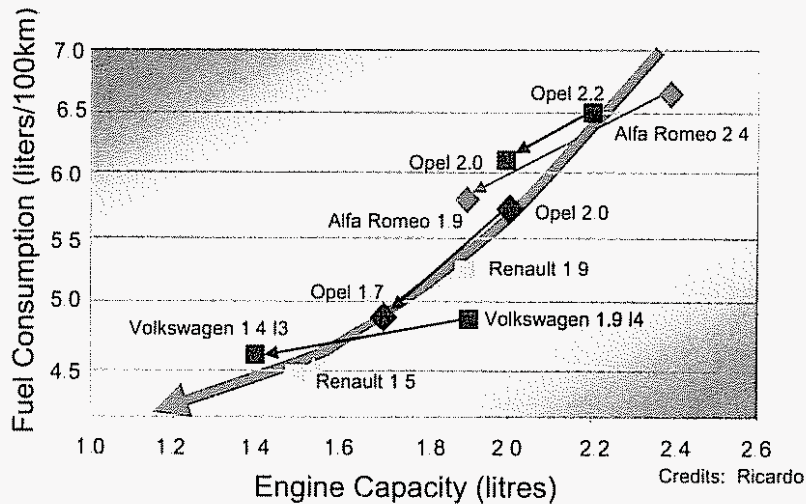

Figure 17: Data from European production vehicles compiled by Ricardo showing that for the same vehicle a downsized diesel engine with improved turbocharging gives better fuel economy over the New European Driving Cycle.

It is apparent from the data of Figures 16 and 17 that downsizing an engine while maintaining power by turbocharging gives better fuel economy. This, combined with the sensitivity analysis on the benefits of electrical assist strongly point to the need of engine downsizing and improving turbocharging technology. These results were used to design and test 2<sup>nd</sup> generation prototypes of electrically assisted turbochargers.

## 2.2 Design and Test 2<sup>nd</sup> Generation Prototype:

Test results of Figure 10 show the need to improve shaft stability of e-Turbo<sup>TM</sup> designs. This was done through the choice of induction motor technology and improved bearing designs. In addition, turbocharger temperature needs to be controlled so as not to exceed acceptable levels usually dictated by oil requirements. However, with the introduction of electrical machinery, further temperature constraints are introduced. Extensive testing was done under road load conditions to determine e-Turbo<sup>TM</sup> on/off time (Figure 18).

## Vehicle Duty-Cycle Recording @ Several Conditions

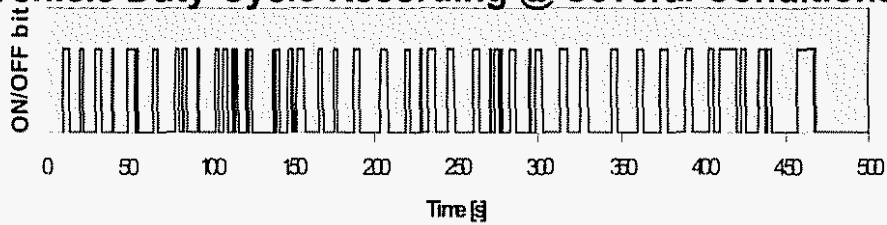

Figure 18: e-Turbo™ ON/OFF recording under road load conditions

Statistical analysis of the data was conducted to determine representative duty cycles under various road conditions (Figure 19).

	City	Mountain	Highway	Country Road
Duty Cycle (%)	7%	19%	3%	6%
Average ON time (sec)	1.1	2.2	1.5	1.3
% cumulated after 2 sec	91%	58%	83%	86%

Figure 19: Statistical analysis of e-Turbo™ duty cycle under representative road conditions

These data were used in a thorough finite element analysis of heat transfer to optimize the design for best cooling. One example of finite element analysis results is shown in Figure 20 below. The design of the e-Turbo™ was improved with particular emphasis on heat flow path to get acceptable temperature under all operating conditions as shown in Figure 21.

In addition to balancing and cooling considerations, aerodynamics are significantly driven by turbocharger speed. The availability of electrical power affects the ability to run turbochargers at desired speeds necessitating aerodynamic designs specifically suited to electrically assisted turbochargers. A compressor wheel was designed specifically for the 2<sup>nd</sup> generation e-Turbo™.

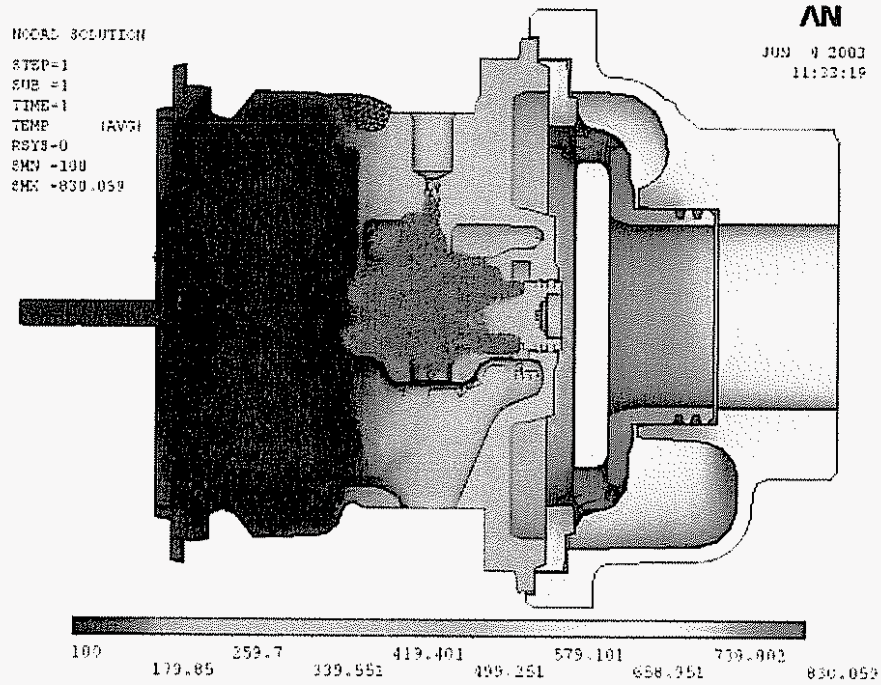

Figure 20: Finite Element Analysis of heat transfer in an e-Turbo™

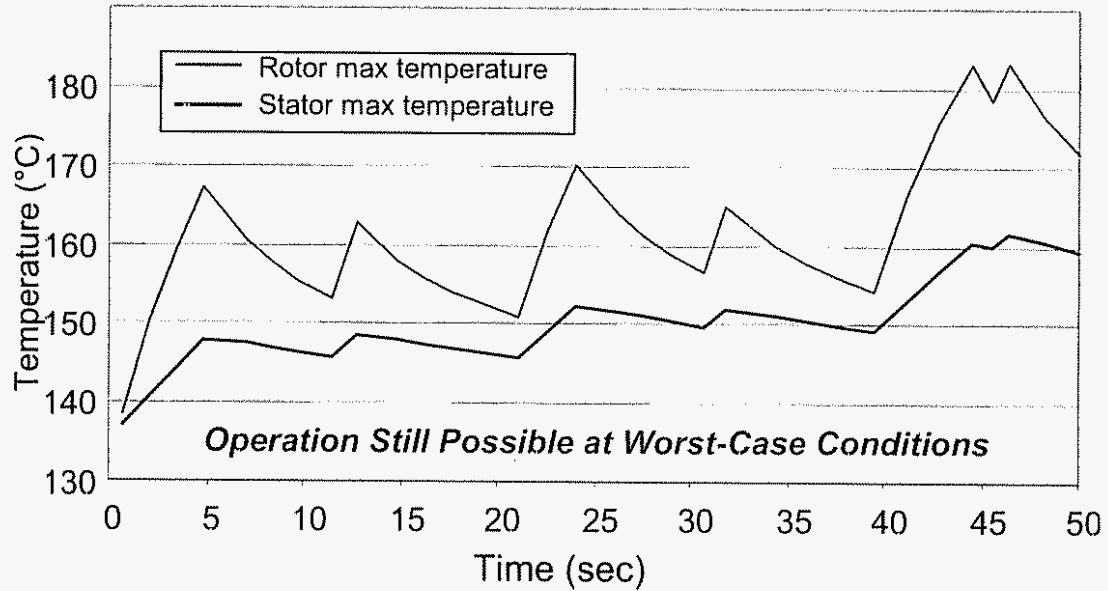

Figure 21: Rotor and stator temperature of e-Turbo™ under severe duty cycle conditions

Figure 22 shows a photograph of second generation e-Turbo™ hardware.

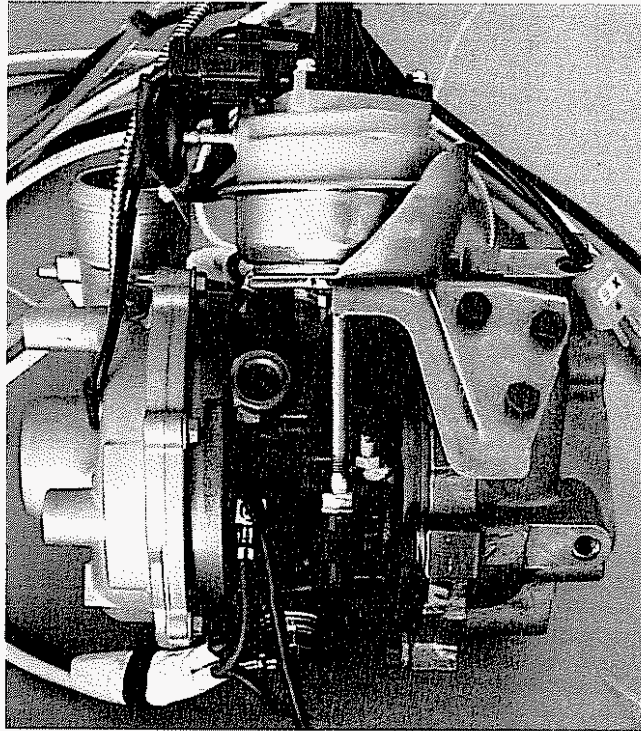

Figure 22: Photograph of second generation e-Turbo™ hardware

### 2.3 Evaluate and Confirm Benefits of e-Turbo™:

The primary benefits that e-Turbo™ application is aimed at are (a) fast response (b) torque shaping and (c) electrical power generation and associated fuel economy improvement. All of these benefits were confirmed by conducting a combination of mathematical simulation and actual engine and vehicle tests.

Figure 23 shows the transient response of a diesel engine equipped with e-Turbo™. Intake manifold pressure is used as a measure of response. It is seen that response is much faster with the e-Turbo™ under both cold and hot engine conditions. It should be noted that not only is the response faster, but the final boost level is much higher which, reflects itself in torque shaping benefits noted later.



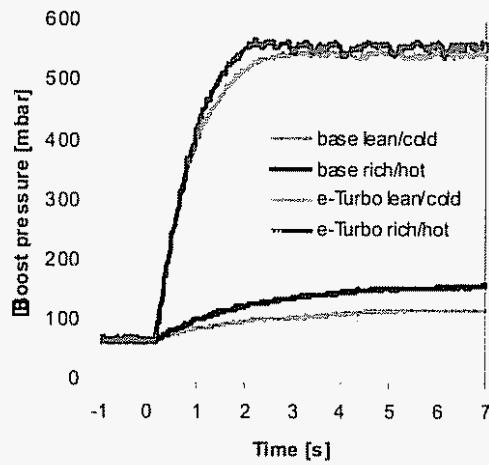

Figure 23: Transient response of a diesel engine with e-Turbo™ under cold and hot conditions

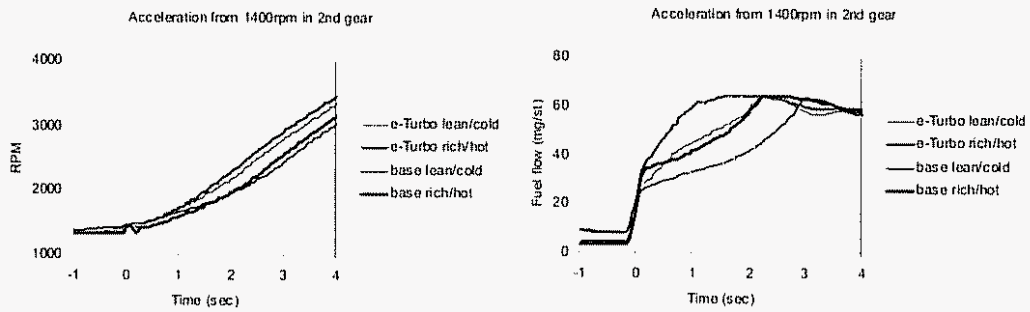

Figure 24: Transient response of e-Turbo™ diesel engine powered passenger vehicle in second gear

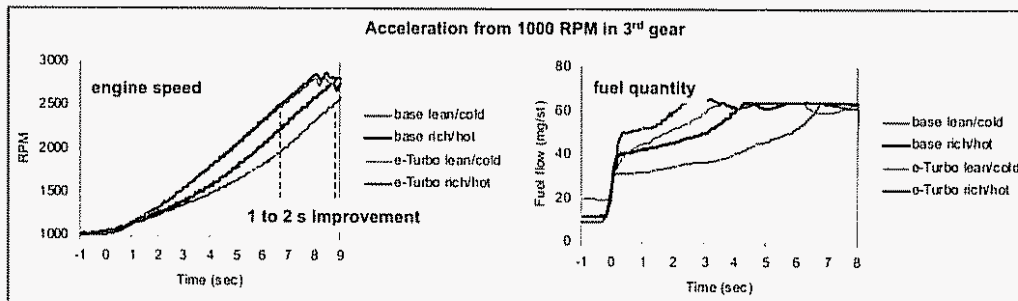
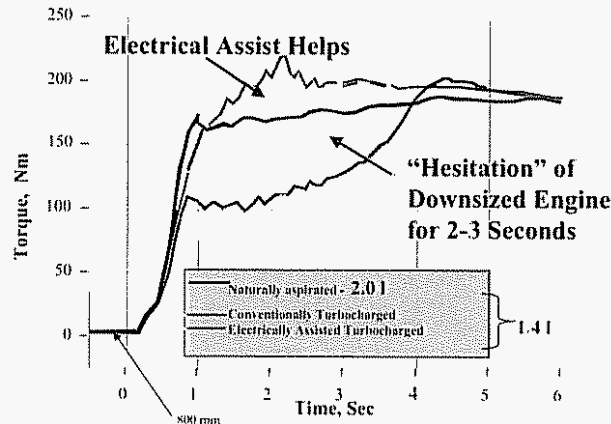

Figure 25: Transient response of e-Turbo™ diesel engine powered passenger vehicle in third gear

Figures 24 and 25 show the results of vehicle tests. Engine speed and fuel injection quantity were measured during the vehicle transient and are used as a measure of response. It is seen that under cold or hot conditions, in second or third gear, e-Turbo™ improves vehicle response by 1-2 seconds.



Simulated Transient Performance

Data Courtesy FEI

Figure 26: Simulated response of a diesel engine powered vehicle with downsized engine with and without electrically assisted boost

It is interesting to compare this with the need for response improvement quantified in Figure 26 taken from Reference 7. It is seen that a downsized diesel engine with a conventional turbo falls short of meeting expected torque by 2-3 seconds. A downsized engine equipped with e-Turbo™ improves response by approximately the same amount with further improvement possible in future designs. This further improvement is a part of the design and development effort associated with the third generation e-Turbo™. Thus, e-Turbo™ application appears to meet the need of fast response.

Figure 27 shows the benefits of torque shaping using e-Turbo™. Boost pressure is used as a measure of torque. The figure shows the boost pressure vs. engine speed for a baseline, variable geometry (VNT) turbocharger equipped diesel engine. In the same figure is plotted the boost pressure achievable with the use of an e-Turbo™. It is noted that at speeds greater than 1700 rpm, electrical power is no longer needed to supplement turbocharger power.

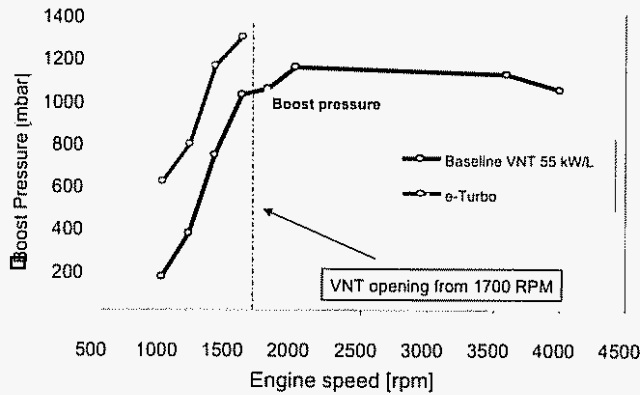

Figure 27: Boost response of a baseline VNT diesel engine and e-Turbo™ diesel engine

Figure 28 is a further development of the same concept. The boost vs. speed characteristic of the base VNT equipped diesel engine is shown. On the same graph the boost characteristic of a high performance (high power density) diesel engine is also shown. As expected, the high performance engine develops high boost (and hence high torque) at high engine speeds when turbocharger power is adequate to supply engine air flow needs. However at speeds lower than 1500 engine rpm there is not enough exhaust energy (power) to supply the air flow demanded by the engine to maintain a reasonable torque at low speeds (expected from a high performance engine). The increased boost pressure developed with the use of e-Turbo™ is shown. It is thus seen that e-Turbo™ can be applied to shape the torque curve of high performance engines at low engine speeds.

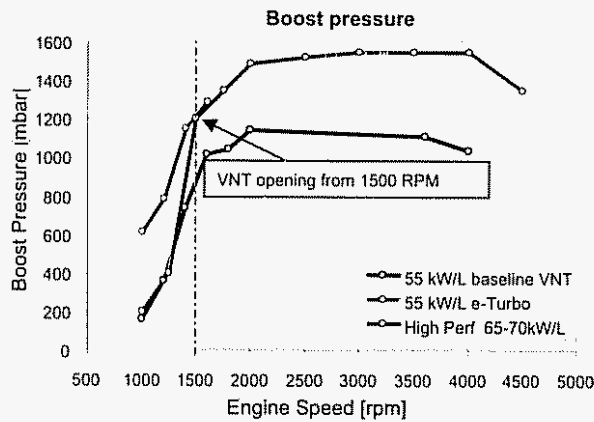

Figure 28: Boost response of a high performance diesel engine, VNT diesel engine and e-Turbo™ diesel engine illustrating torque shaping potential

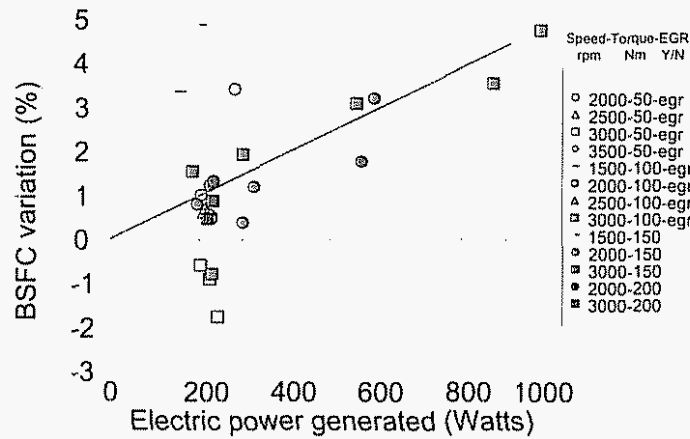

Figure 29: Electrical power & fuel economy improvement with e-Turbo™

Figure 29 shows the electrical power generation potential of the e-Turbo™. A wide range of engine speed (rpm) and torque (N-m) conditions with and without exhaust gas recirculation (egr) are shown. It is seen that under high engine speed and load conditions considerable electrical power (up to 2 kW) can be generated and brake specific fuel consumption (BSFC) is improved by up to 5% in some conditions. However, Figure 30 illustrates that under low speed and low load conditions there is just not enough exhaust energy (power) to generate electrical power.

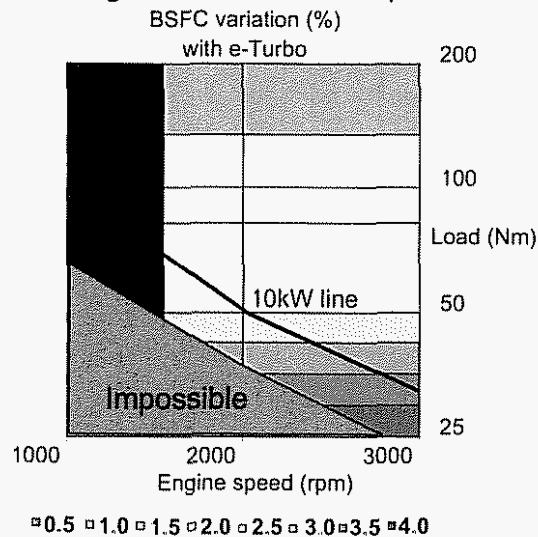

Figure 30: Illustrating that electrical power generation with e-Turbo™ is not possible under low load-speed conditions and showing 0.5 to 4.0% improvement in fuel economy over the load-speed range

Note that this is precisely the condition that represents "torque deficit" area and electrical power was required to supplement turbocharger power to shape the torque curve. We should not therefore expect to be able to generate electrical power under these conditions.

#### 2.4 Development of 3<sup>rd</sup> Generation Prototype:

e-Turbo™ has demonstrated all the expected benefits of fuel economy improvement, torque shaping and fast response. However, there are areas where further improvement is possible and this task is defined as the development of third generation prototypes. One clear example of development needs is shown in Figure 31. Turbocharger wheels and blades are designed to be aerodynamically efficient over the widest possible operating range. However, under conditions where supplementary electrical power is used, turbocharger speed increases and results in a mismatch between exhaust flow and blade geometry, resulting in a decrease in efficiency, as shown in Figure 31. The efficiency appears to decrease further with increased power supply to the turbocharger. Aerodynamic re-optimization of the turbine wheel is identified as one of the needs for improvement.

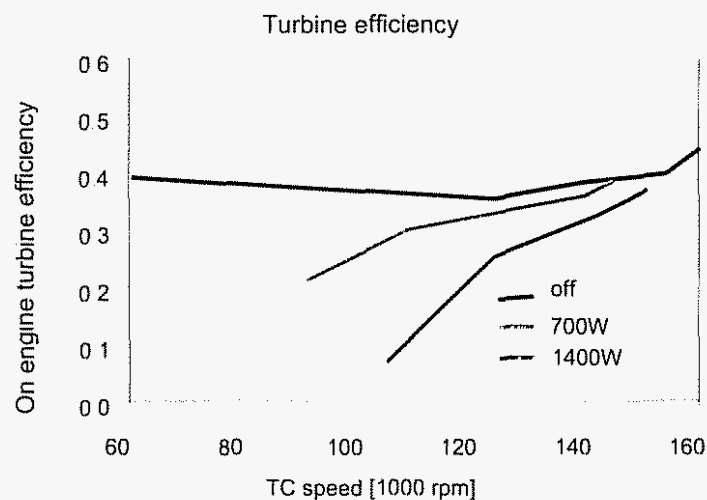

Figure 31: Illustrating turbine efficiency drop-off with supplementary electrical power supply

## 2.5 Simulation of e-Turbo™ Application to 4.0 Liter Engine:

In general, the size of engines used in US vehicles is greater than 2.0 liter displacement. The e-Turbo™ project was directed at the development of a turbocharger suitable for a 2.0 liter displacement engine in order to keep hardware issues to a minimum and demonstrate feasibility of the design and benefits of the concept. Besides, a turbocharger of this size can readily be applied to a larger 4.0 liter displacement engine in a bi-turbo configuration. One clearly defined task for this project was to take the experimental results and simulation tools developed for the 2.0 liter engine and apply them to a 4.0 liter engine suitable for use in US vehicles. The 4.0 liter engine selected for these simulations has a rated power of 190 kW and a peak torque of 550 N-m at 2000 rpm. Results of simulation with and without e-Turbo™ are shown in the following paragraphs and figures. The focus of the work is on torque shaping and transient response.

Figure 32 shows the baseline torque vs speed simulation of a 4 liter engine equipped with two small turbos (one for each bank, also called bi-turbo configuration) as well as one large turbo. The two curves fall exactly on top of each other and are not distinctly visible. Note that this is steady-state torque curve.

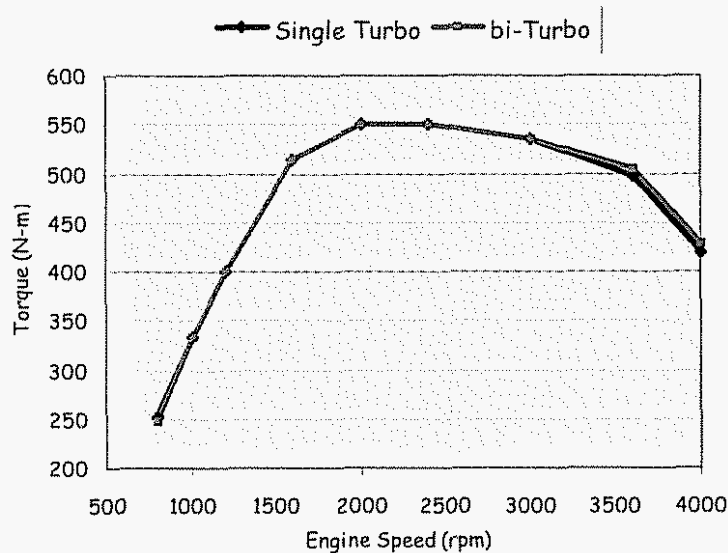

Figure 32: Simulated baseline (no e-Turbo™) torque characteristics of a 4.0 liter diesel engine equipped with bi-turbo and single turbo configurations

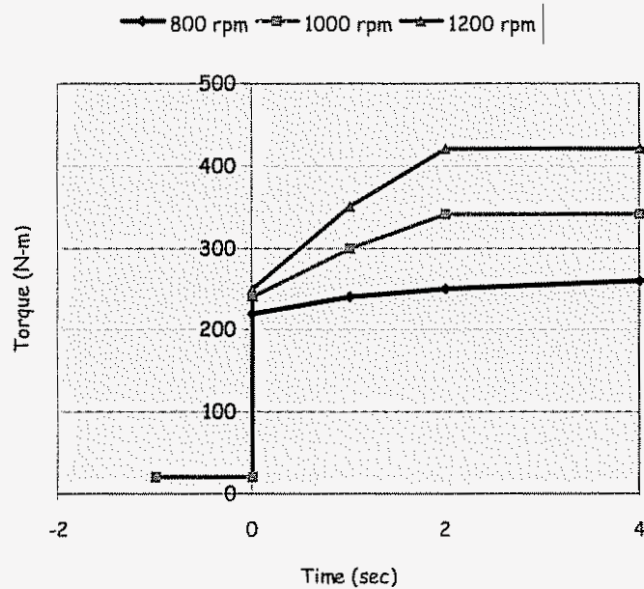

Figure 33: Simulated transient response characteristics of a 4.0 liter diesel engine at 800, 1000 and 1200 engine rpm in a bi-turbo configuration

Figures 33 and 34 also show the same baseline configurations but for transient torque response. Torque vs time at three constant engine speed conditions is shown.

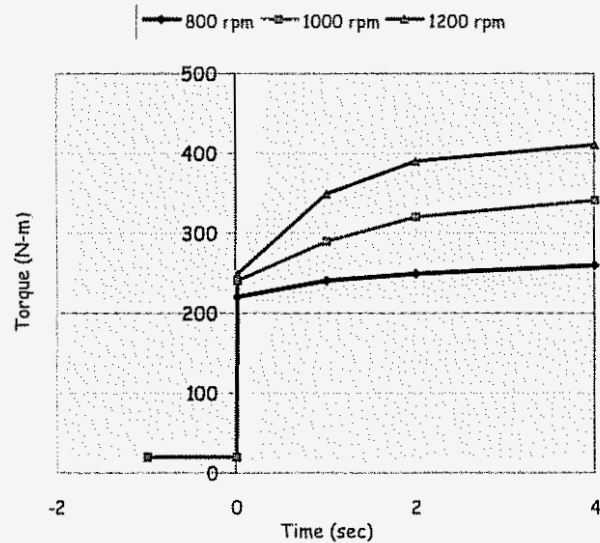

Figure 34: Simulated transient response characteristics of a 4.0-liter diesel engine at 800, 1000 and 1200 Engine rpm in a single turbo configuration

Figure 35 demonstrates steady state torque shaping capabilities with e-Turbo™ in the bi-Turbo configuration.

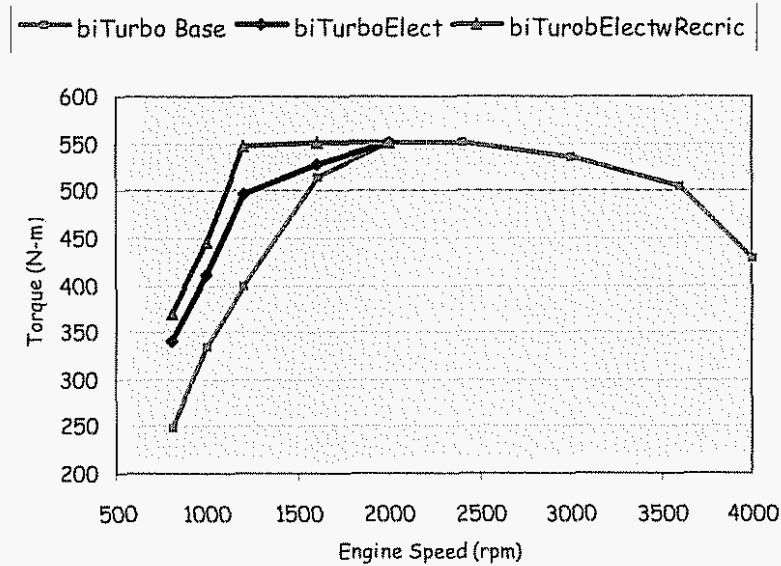

Figure 35: Simulated low speed torque shaping with e-Turbo, 4.0 liter diesel engine in a bi-turbo configuration, with and without recirculation valve. Baseline bi-turbo torque curve is also shown for comparison.

It is seen that considerable torque increase over the baseline configuration is possible. This should be compared with Figures 27 and 28 showing similar results for a ~ 2.0 liter engine. In Figure 35 three torque curves are shown - two with e-Turbo™ and one baseline. The two e-Turbo™ torque curves are with and without a "recirculation valve". Reference has been made to compressor surge. This is a phenomenon of destructive air flow instabilities under low engine speed and high boost pressure conditions. Such a condition is greatly exacerbated when variable geometry turbines and/or electrical assist is used. A recirculation valve prevents flow instabilities. An alternate, more elegant technology is to use a variable geometry compressor. This technology is discussed in greater detail in Section 5.0 below. Figure 35 confirms that a surge prevention device (such as a recirculation valve or variable geometry compressor) enables full torque shaping benefits of e-Turbo™ to be realized. Figure 36 shows similar results with a single large turbo configuration instead of two small turbochargers (one for each bank). It is seen that similar torque-shaping benefits are realized.



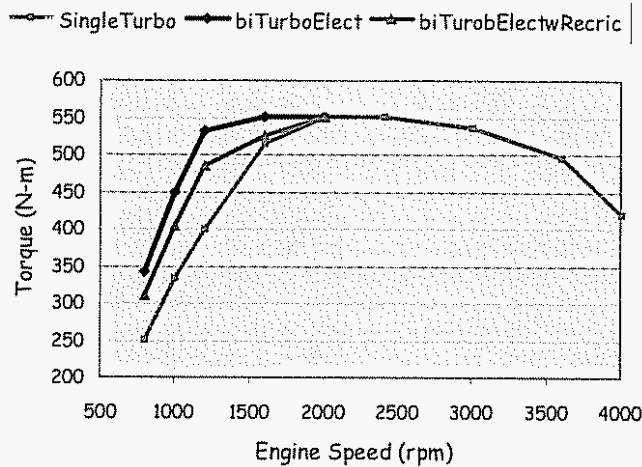

Figure 36: Simulated low speed torque shaping with e-Turbo. Single turbo configuration with and without recirculation valve. Baseline single turbo torque curve is also shown for ready comparison

Figure 37 compares bi-Turbo and single Turbo configurations both with electric assist. It appears that both configurations achieve equivalent torque. But, from a power demand point of view a single turbo configuration may be preferable. It needs about 2.1 kW of power input vs. 2x1.4 i.e. 2.8 kW for a bi-Turbo configuration.

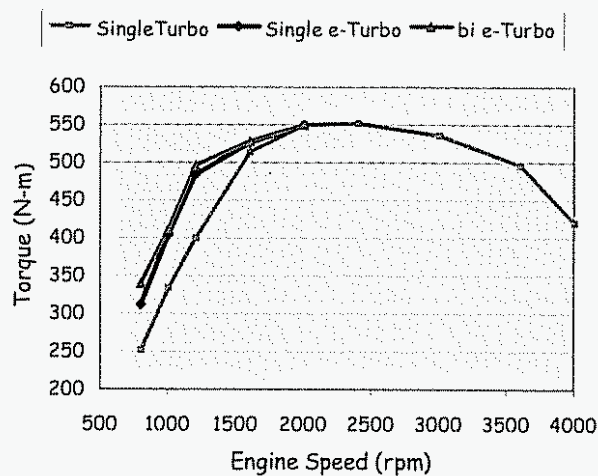

Figure 37: Simulated comparison of torque shaping with bi-turbo and single turbo BOTH with electric assist compared to baseline

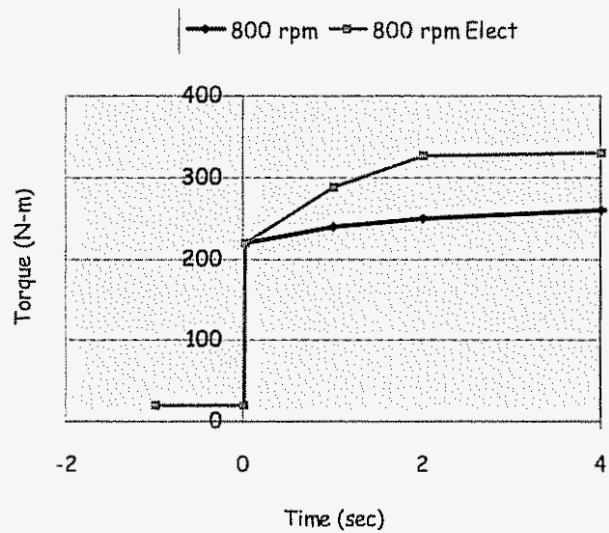

Figure 38: Simulated transient response of 4.0 liter diesel engine with and without electrical assist in a bi-turbo configuration at 800 rpm

Engine simulation was also done to quantify transient torque response with a 4.0 liter e-Turbo™ engine. Figures 38 and 39 show transient torque response (torque vs time) after a step increase in fueling at 800 and 1200 rpm. Results with a bi-turbo configuration for the baseline and electric assist (also bi-turbo) case are shown. In each case, it is seen that substantially faster torque response is obtained with the use of e-Turbo™.

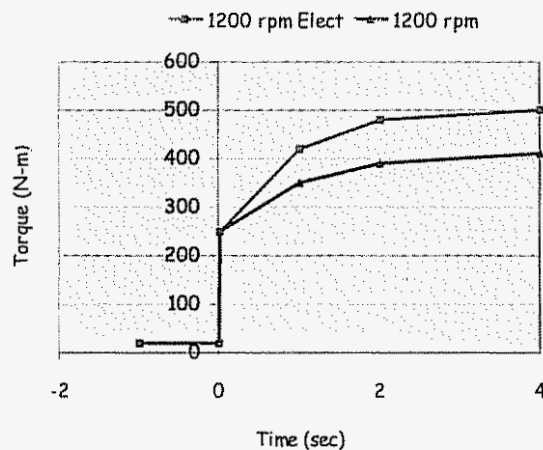

Figure 39: Simulated transient response of 4.0 liter diesel engine with and without electrical assist in a bi-turbo configuration at 1200 rpm

Figure 40 compares the increase in torque with and without electrical assist one second after fuel step increase. Bi-Turbo configuration is compared to its baseline and single turbo configuration is compared to its baseline (baseline is without electric assist). It is important to remember that the baseline bi-Turbo configuration is more responsive than the single turbo configuration by ~5%. This is because the inertia of a single large turbo makes it slower to respond. When comparing single to bi-turbo configurations it is important to account for this 5% additional responsiveness of the bi-turbo configuration. It is worth noting that the steady state torque of both configurations is the same. We have already noted that less electrical power is required for steady state torque shaping for the single turbo configuration. But the bi-Turbo configuration is more responsive. For example at 800 rpm, the bi-Turbo configuration gives 35% more torque compared to its baseline and (35+5) 40% more torque compared to the single turbo baseline. On the other hand a single e-Turbo™ gives about 24% more torque than its baseline. Thus, it appears that from a transient response point of view a bi-turbo configuration is preferable.

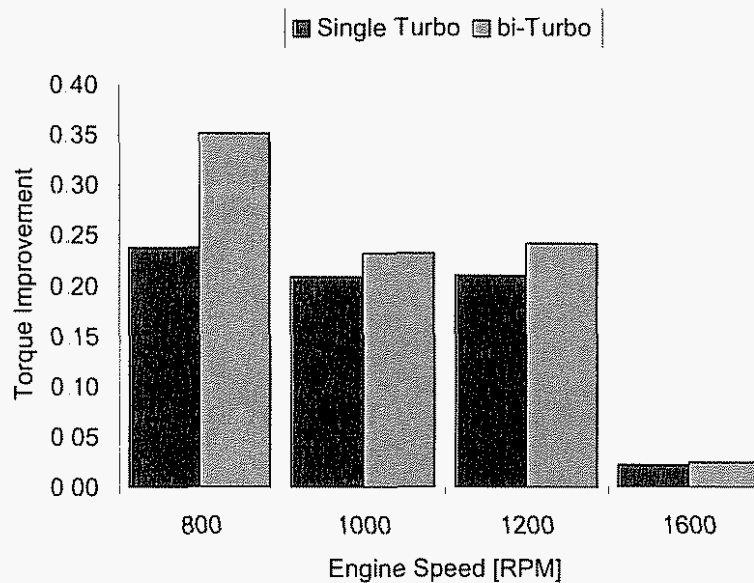

Figure 40: Simulated transient response measured as torque increase one second after step increase in fueling. Single and bi-Turbo configurations with and without electrical power are compared.

### 3.0 Integrated Control System:

In order to realize the full potential of electrically assisted turbocharging it is necessary to develop a robust control system based on model based controls, innovative logic, use of sensors and integration with the vehicle/engine control system. e-Turbo™ control technology would also have to interact with a wide range of other parameters such as battery state of charge and exhaust catalytic treatment. Conventional control systems based on single parameter closed loops can result in sub-optimization. With multi-parameter control overall system optimization is possible and the need for fast model based controls is greatly accentuated. Figure 41 illustrates Honeywell expertise in the process control area, in this example, specifically for paper mills. Signals from hundreds of sensors are processed and actuators controlled to manage liquid slurry poured at one end, moving faster than 100 km/hr, with close control of humidity, thickness and consistency all along the way. This is done using overall system optimization and model based controls. The purpose of this project is to bring that expertise to bear on the control of e-Turbo™, diesel exhaust aftertreatment and battery charge.

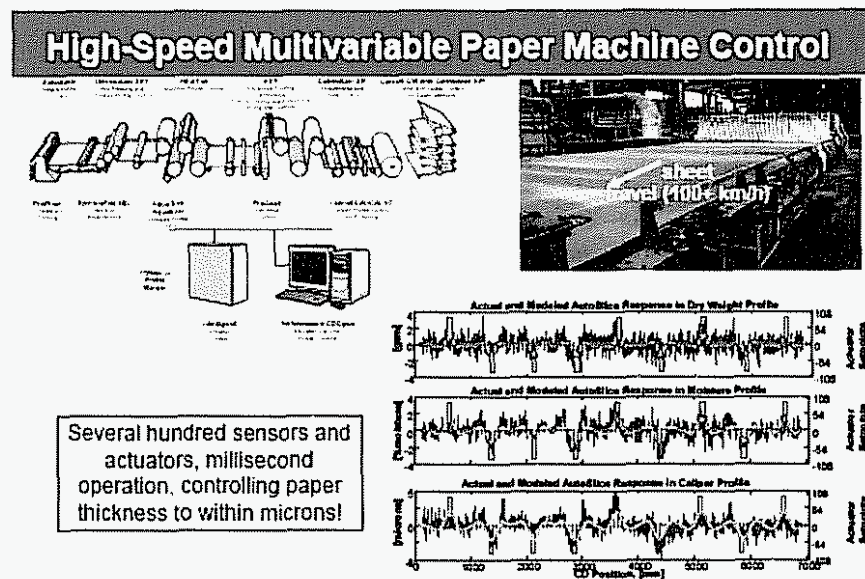

Figure 41: Illustrative example of multi-parameter control with model based control system for overall system optimization

### 3.1 Simulate & Demonstrate Benefits of Advanced Sensing & Control:

This task consists of developing and testing novel advanced control strategies for a turbocharged diesel engine. The considered actuators consist of the traditional EGR valve and the VNT vane positions, plus a novel electrical assist actuator. In addition to two traditional sensors, for intake manifold pressure (MAP) and the intake manifold flow (MAF), we considered two new sensors under development by Honeywell: a NO<sub>x</sub> emissions sensor and a particulate matter (PM) sensor. Due to the lean combustion in Diesel engines, the familiar oxygen sensor in gasoline engines is of less relevance. NO<sub>x</sub> and PM control are crucial for diesel engines and in situ sensors for these emissions are expected to substantially improve Diesel emissions control, especially in light of advances in turbocharging such as electrical assist.

In order to most expediently accomplish this task an existing Garrett turbo-diesel engine simulation model in Matlab/Simulink environment was adopted to include electrical assisted turbocharging (e-Turbo™) physics. In addition, we developed NO<sub>x</sub> and PM emissions sub-models and implemented these into engine model. Since novel NO<sub>x</sub> and PM sensors are currently under development at Honeywell, NO<sub>x</sub> and PM emissions sensor feedback is incorporated explicitly into the control strategy. We explored and developed multivariable strategies for controlling the turbo-diesel engine together with the e-Turbo™. Actuators include: EGR position, VNT position, and e-Turbo™ power input. Desired performance results for associated sensors include: boost level, boost level overshoot, NO<sub>x</sub> and PM emissions constraints, minimization of fuel consumption, and of course the ability to meet driver torque request. A novel method of calibrating true multivariable control strategies and compared it to conventional PID single-variable control method was developed. We explored dynamics and capability to control engine boost in response to pedal step transient while imposing constraints on emissions and fuel economy. Emissions and fuel consumption feedback is assumed available in real-time during engine transients via appropriate sensors.

The results of this task demonstrated a novel method for calibrating true multivariable control, which showed significant reduction in calibration time and improved performance over conventional single-variable methods.

This achieved time to boost by faster than 2 second and while maintaining simulated PM levels below the smoking limit. The potential to achieve smokeless acceleration has been demonstrated via simulation, assuming availability of PM sensor feedback. Due to the challenges of modeling diesel engine emissions, PM sensing is required in order to design a control system to guarantee smokeless acceleration. The addition of the e-Turbo™ achieved time to boost faster than 1 second. Benefits of e-Turbo™ at the vehicle level follow: faster acceleration, longer turbo life, and lower smoke/PM emissions. We evaluated control technologies and selected the multiparametric programming approach to generate an explicit model-based predictive controller.

Multiparametric programming (MPT) allows a feedback controller to be designed to optimally coordinate all actuators in the turbodiesel engine, but without the usual requirement of performing the optimization in real time. This control technology can easily address physical constraints on the actuators and also can satisfy constraints on the emissions and turbocharger rotation speed (Figure 42). An explicit MPC controller for one operating point (engine speed and torque) was designed and tested.

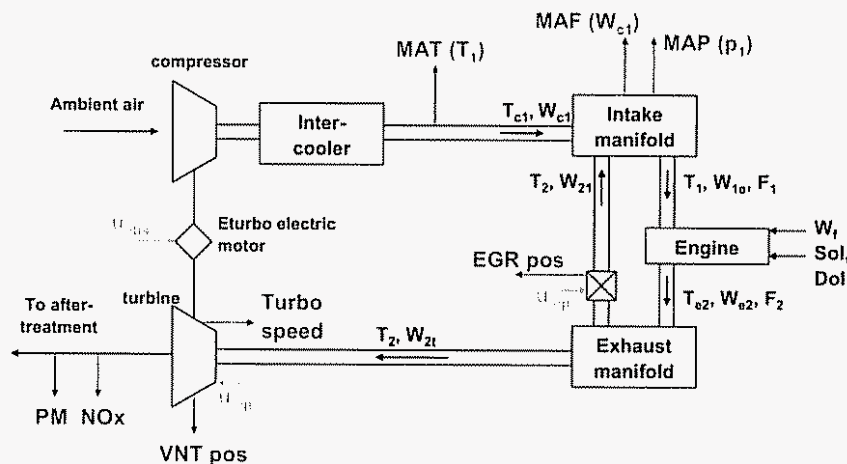

Figure 42: Sensing and control architecture for e-Turbo™

We then extended the explicit MPC control scheme to accommodate multiple operating points of engine speed and torque. This was achieved by developing two sets of model parameters - one for low engine speeds and one for high engine speeds, and a method to switch automatically. We compared

the performance of the developed control scheme against the controller without the emissions sensing. A significant improvement can be realized by the added emissions sensors as shown in Figures 43 and 44.

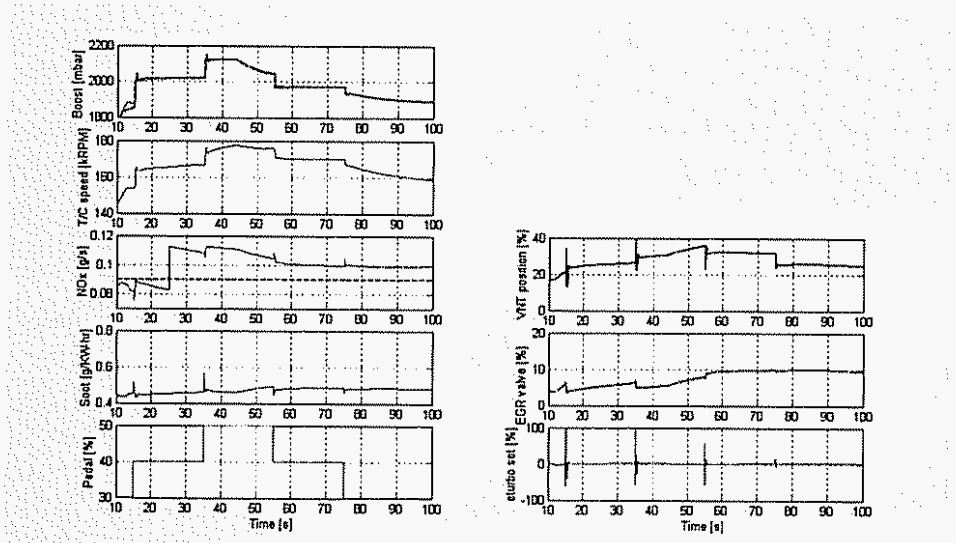

Figure 43: Illustrative results of multi-parameter integrated control without the use of NOx sensor showing that actual NOx is considerably higher than NOx set point.

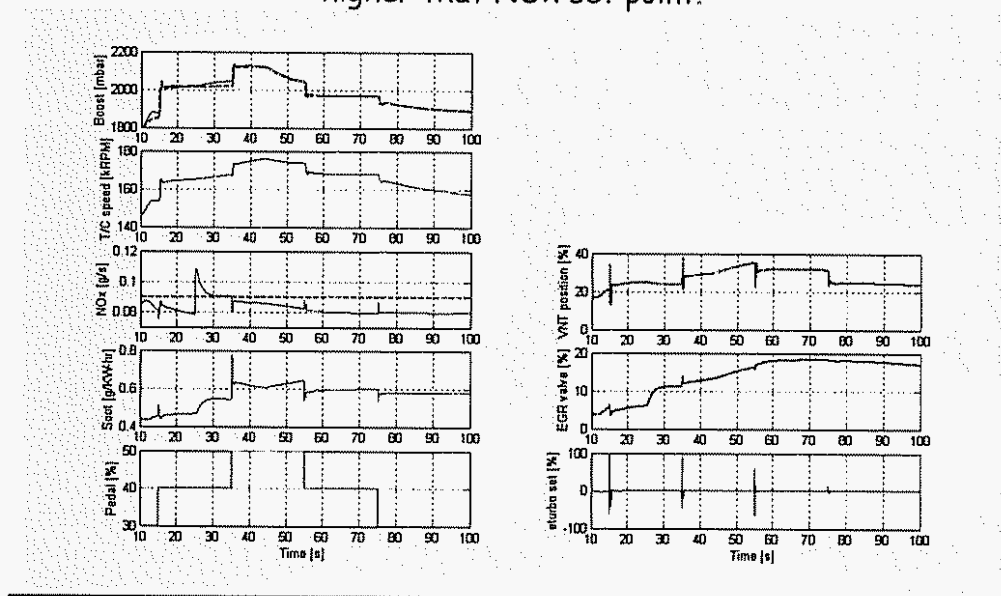

Figure 44: Illustrative results of multi-parameter integrated control with the use of NOx sensor showing that actual NOx is much closer to NOx setpoint

### 3.2 Integrated e-Turbo™ and Battery Charge Management:

The e-Turbo™ provides an extra degree of freedom to the engine design and control. It has already been shown that with the e-Turbo™, faster turbo response is achievable. However, the e-Turbo™ requires extra power during transients, which ideally does not subtract from the engine brake torque during the transient. Thus, an idealized system configuration would include a stand-alone battery to power the e-Turbo™ during transients. The e-Turbo™ would have sufficient capability to re-charge the battery during steady-state operation at higher engine speeds and loads. The activities and accomplishments within this task explore the potential of the multivariable control strategy to draw power from the battery, and to charge it again, thus maintaining a healthy battery state-of-charge at all times, and simultaneously maintaining performance, emissions, and fuel economy.

We developed a baseline multivariable model-based control algorithm for electrical boost control. The controller was designed to take a setpoint command for power generation via the electrical motor in an electrically assisted turbocharger. A battery State-of-Charge (SOC) model was developed and integrated into engine simulation model. This was used to explore the dynamics of battery capability and control strategies to provide power to e-Turbo™ during boosting transient events. The use of the model was further extended to explore the capability of the engine and controls to charge the battery during steady-state operation, while maintaining emissions targets and minimizing engine fuel consumption.

We developed the control scheme to maintain battery state-of-charge to small excursions around the desired SOC. The strength of the multivariable control is such that this scheme was incorporated directly into the boost and emissions control scheme described above. Additional actuators and sensors may be incorporated easily into the overall optimization-based control scheme, which may then be implemented in terms of efficient lookup tables using the multi-parametric (MPT) technology described above.



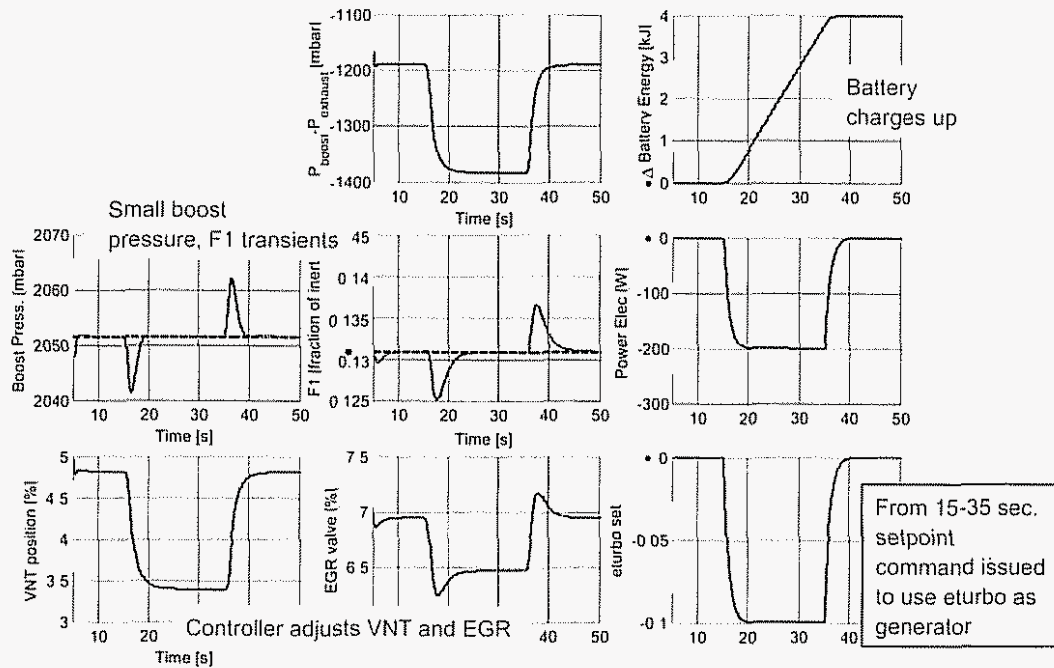

Figure 45: Illustrative results of battery state of charge with e-Turbo™

The results of this work demonstrated in simulation that the multivariable control allows the setpoint command to be met with simultaneous management of operating constraints, including engine-out emissions. Transients due to switching of electrical boost are minimized, Figure 44. We demonstrated the ability to manage engine actuators to control battery SOC following a pedal step transient utilizing electrical assistance to the e-Turbo™. During pedal-step transient, potential to draw power from stand-alone battery and to restore SOC during steady-state operation was demonstrated. Simulation shows that significant boosting capability is possible with a reasonably sized battery and that battery draw-down and recharging rates are within reason. It appears the system has the capability to control rate of battery charging to achieve desired steady-state battery SOC of 0.7. Figure 45 shows the battery model as implemented in Matlab. Use of the model allows realistic control objectives to be met, such as maintaining SOC under different engine operating regimes.

### 3.3 Integrated e-Turbo™ and Exhaust After-treatment:

It is recognized that after-treatment devices impose additional demands upon the engine and control system and have the potential to impact performance and fuel economy. However, the addition of the e-Turbo™ provides an avenue to mitigate some of these impacts. For example, during Diesel Particulate Filter "DPF" regeneration, the DPF is likely to require different exhaust gas conditions than would naturally arise due to the driving cycle. With full multivariable control and the e-Turbo™, engine actuators can be adjusted to best meet DPF requirements and minimize impact on the engine/system while meeting driving cycle requirements without the imposition of penalties on performance and/or fuel economy.

As described below, the DPF is inherently challenging to model. For that reason, the introduction of sensing will be a necessary technical component to the success of the aftertreatment control strategy. A successful DPF regeneration requires the combustion of the accumulated particles in the filter often through the addition of fuel into the exhaust stream. The information required for a successful regeneration includes: mass of collected particulates sufficient for combustion, sufficient oxygen concentration and flow, sufficient temperature, and the satisfaction of a maximum temperature limit to avoid overheating the DPF.

The scope of the project limited detailed investigation to only the Diesel Particulate Filter - DPF - system. Nevertheless, independently of this project, we were able to explore alternative aftertreatment catalytic devices to reduce precious metal content and regeneration cycle impacts. Simulation of the DPF system allowed an understanding of the system operation and requirements and potential impact on engine and control system. We were able to develop aftertreatment physics for the engine model, starting with DPF (diesel particulate filter). Key elements of the DPF sub-model include calculations for pressure drop; PM mass filter, storage & oxidation; and DPF surface temperature. The DPF model allows analysis of control strategies during PM accumulation and regeneration. This task was more involved than expected. Due to non-linear behavior of DPF with particle size, degree of accumulation and DPF design variants, it is difficult to develop a universal DPF model, but it will be possible to calibrate for a single design. We explored control strategies to control engine exhaust

temperature, flow rate and oxygen concentration to best meet DPF requirements.

Results from sub-model equations for DPF pressure drop and surface temperature calculations, shown in Figure 46, show good agreement with published literature on DPF performance and capture the non-linear regeneration processes of self-initiation and burn-off. The results also demonstrated effectiveness in adjusting engine exhaust gas temperature toward DPF light-off requirements (Figure 47) with only airside engine controls (VNT, EGR, or e-Turbo™). Results show that engine boost, O<sub>2</sub> and post-turbine temperatures are highly coupled. This suggests that the additional degree of freedom offered by e-Turbo™ (with electric power generation capability and/or turbine-by-pass) may enable DPF regeneration without adding fuel and without loss of engine boost.

Electrical power generation can be used as one parameter to control exhaust temperature to meet the needs of catalyst or DPF regeneration. Figure 48 shows that using the e-Turbo™ to generate as little as 250 W of electrical power it is possible to get modest increases in exhaust temperature over a wide range of speed and load conditions. Higher power generation will give more increase in exhaust temperature, as needed. This also reinforces the need of an integrated control system optimizing e-Turbo™, battery, catalytic aftertreatment and engine performance and emissions.

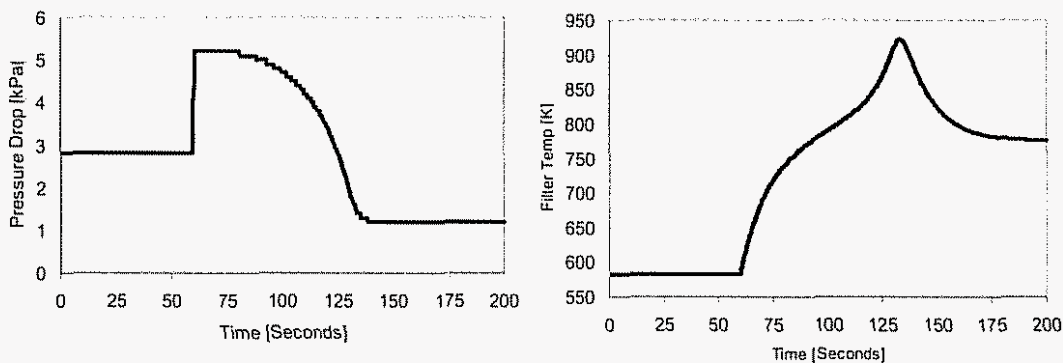

Figure 46: Pressure drop (kPa) and DPF surface temperature (K) during self-ignition regeneration event as simulated with model in Matlab due to step change in engine exhaust temperature at 60 seconds - shows self ignition and burn-out as soot level drops during regeneration burn off (not shown)

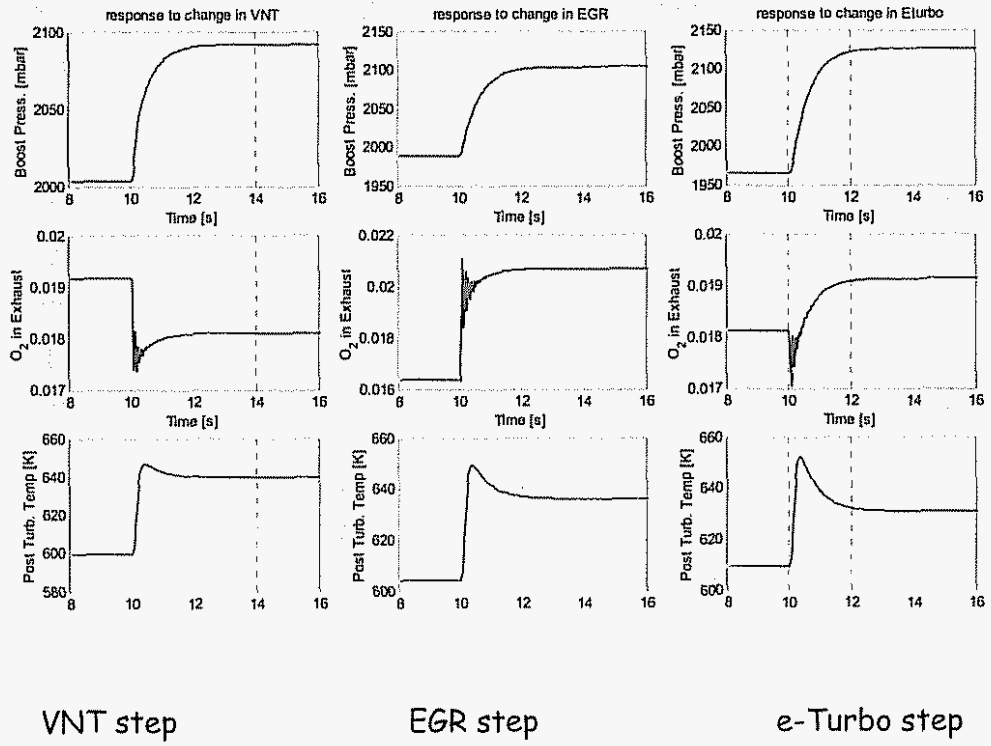

Figure 47: Step changes in VNT, EGR, and e-Turbo power from left to right and resulting O<sub>2</sub> and engine turbine out temperature below each. Shows potential to control O<sub>2</sub> and temperature into DPF and that it may be possible to light-off DPF without burning additional fuel.

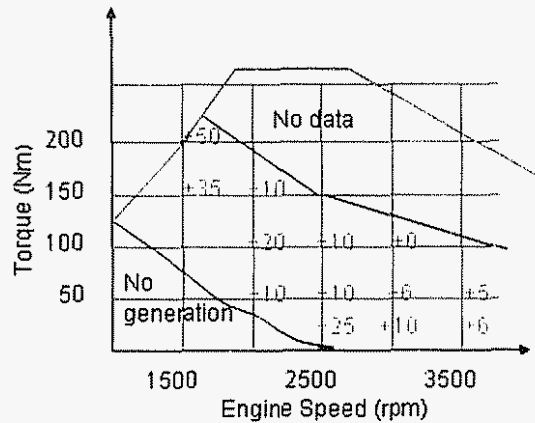

Figure 48: Possible exhaust temperature increase with 250 W of power generation with e-Turbo™ under various load-speed conditions

#### 4.0 Incorporation of Low Inertia Turbocharger Technology to Minimize Power Demand:

The criticality of electrical power demand has been mentioned several times already. One of the modes under which electrical power is demanded is to accelerate the turbocharger when the fuel pedal is pressed (fuel is supplied). The amount of electrical power demanded is influenced by the inertia of the rotating components. Therefore, the development of small, low inertia turbocharger for a 4-6 liter engine is critical to make it acceptable for low electrical power demands. A concept called the IBT with matched turbine and compressor wheel sizes was developed under a separate internal project. It was used to conduct analysis and experiments to show response benefits, develop prototype hardware for proof of concept and compatibility with e-Turbo™.

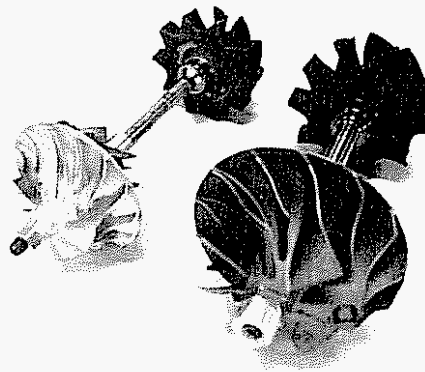

Figure 49: IBT low inertia turbo rotating components compared to conventional turbocharger components of the same flow capabilities

We completed the design and build of a low inertia turbo (IBT) for bench tests. It uses the concept of compressor wheels packaged back to back for compact design delivering a wide range of flow. Figure 49 shows the rotating components of an IBT compared to a conventional turbocharger delivering similar air flow. Rotating inertia is considerably reduced.

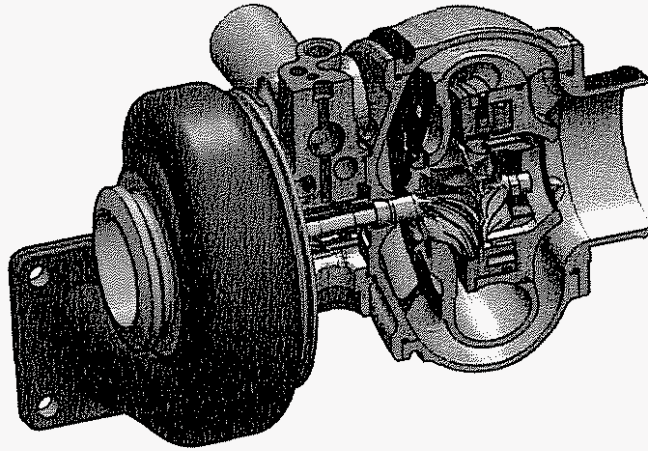

Figure 50: Wrapped inlet configuration of IBT low inertia turbocharger

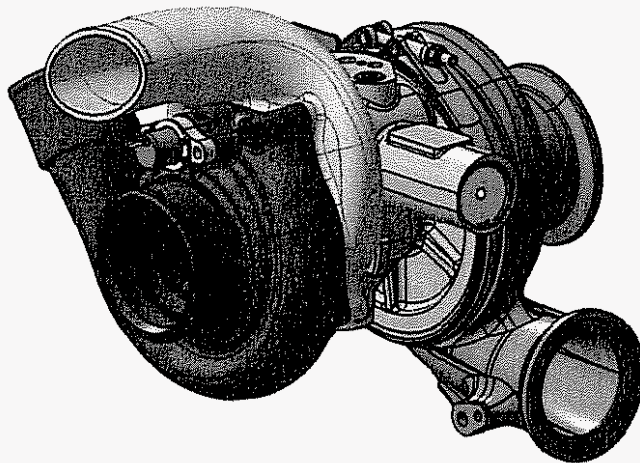

Figure 51: Dual inlet configuration of IBT low inertia turbocharger

Figures 50 and 51 show two variations in the design of this concept incorporated in a complete turbocharger. Further design changes to incorporate e-Turbo™ electrical machinery remain to be done and are beyond the scope of the current project. Reference has already been made to high performance diesel engines ... diesel engines with high power density (kW/L) and high torque. It has been shown that such engines need e-Turbo™ capabilities at low speeds (Figure 28). Such high performance diesel engines also need wide range of air flow rate and intake pressure capabilities that can be delivered by turbo concepts shown in Figures 50 and 51. It is therefore necessary to explore the combination of e-Turbo™ and IBT technologies in a future project.

## 5.0 Incorporation of Variable Geometry Compressor Technology to Take Advantage of e-Turbo™:

Today's compressor technology is unable to take full benefit of e-Turbo™ capabilities. Reference has already been made to destructive air flow instabilities called compressor surge. Surge limits the torque capability of an engine at low speeds, and is further accentuated by the use of variable geometry turbine and/or electrical assist. A variable geometry compressor needs to be designed and integrated into e-Turbo™ to demonstrate benefits.

A variable geometry compressor concept was adapted from designs developed in previous internal projects. Figure 52 shows variable vanes incorporated into the diffuser passage.

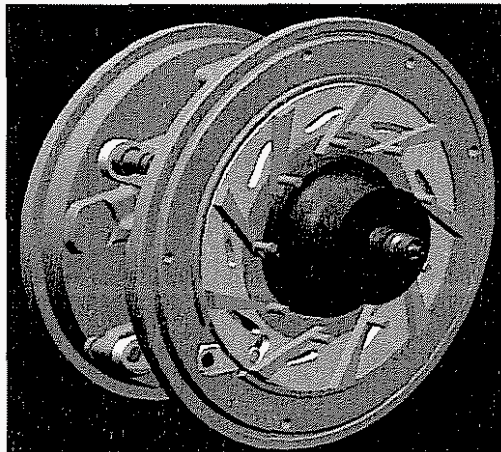

Figure 52: Concept design of movable vanes in the diffuser of compressor

Figure 53 shows a picture of the hardware. Figure 54 shows compressor flow map to illustrate how a variable geometry compressor helps prevent surge. The operating map of a conventional compressor is shown in blue lines. Any attempt to operate the engine at high pressure ratios (high torque) results in compressor surge. The green area shows how variable geometry vanes in the diffuser extends the flow range of the compressor. This enables the engine to develop high torque at low speeds as shown by the red torque curve.

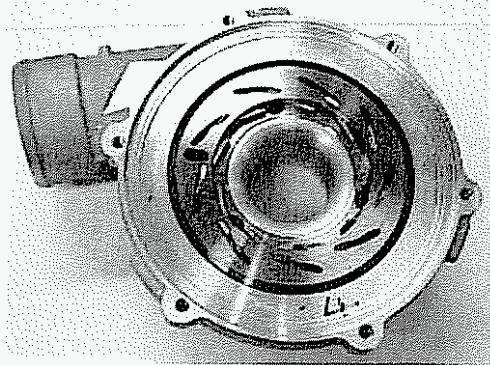

Figure 53: Photograph of variable geometry compressor hardware

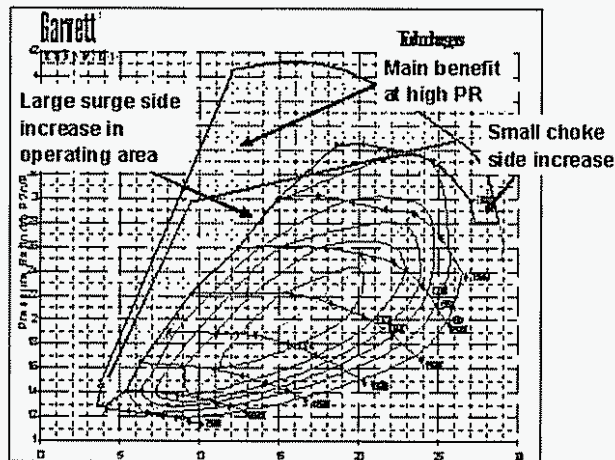

Figure 54: Flow range increase with variable geometry compressor

Tests show that at a pressure ratio 2.8, the VGC range has been increased by 65% and the efficiency has been improved by 3%. This has resulted in a 40% torque increase at 1500 rpm & 25% torque increase at 1200 rpm with a 2 liter 110 kW diesel engine. The variable geometry compressor design needs to be incorporated into the e-Turbo™. Further, it is therefore necessary to explore the combination of e-Turbo™ and variable geometry compressor technologies in a future project.

## 6.0 Summary and Conclusions:

Production vehicle data show that European turbo diesel engine powered passenger vehicles achieve 30-50% better fuel economy than their gasoline engine powered counterparts. If this technology is applied in the



US it can result in very significant fuel savings. Urban emissions control technology for diesel engines is already well underway and a European manufacturer has announced their ability to meet 2007 emissions standards for SUV size vehicles. For widespread use of turbo diesel engines in the US, vehicle response, turbo lag and low speed torque needs to be improved. Electrically assisted turbocharger e-Turbo™ technology is very effective in doing this.

Designs and hardware were developed suitable for a ~2 liter displacement diesel engine. The same hardware can also be applied to a larger 4.0 liter, SUV sized, V engine in a bi-turbo configuration. Alternatively, a larger single e-Turbo™ can be developed (in a future project). Experimental and simulation results with a ~ 2 liter engine and simulation results with a 4.0 liter engine were presented to show that vehicle response is greatly improved by increasing low speed torque and reducing (eliminating?) turbo lag.

It is shown that when full e-Turbo™ capabilities are used, the compressor runs into surge, a destructive flow instability inherent in radial compressor designs. It is shown that variable geometry compressor (VGC) designs can be used to overcome this problem and make full use of e-Turbo™ capabilities. The combination of VGC and e-Turbo™ design remains to be done in a future project.

It is shown that e-Turbo™ can result in significant, if momentary power demands. For a two liter engine power on the order of 1.4 kW needs to be applied. For a 4.0 liter engine in a bi-turbo configuration, 2.8 kW of power is required. If a single large e-Turbo™ is used, then 2.1 kW of power is required to achieve the same low speed torque value under steady state conditions. From the point of view of power consumption, for steady state low speed torque, a single large e-Turbo™ configuration is preferred. However, it is also shown that transient response is better for a bi-turbo configuration. Thus electrical power needs become a significant consideration in the selection of turbochargers for SUV sized engines. Reduction of turbocharger inertia is a very significant consideration. It is shown that innovative designs can be used to reduce the inertia of rotating components significantly. IBT turbocharger designs are presented. The

combination of IBT with e-Turbo™ designs remains to be done in a future project.

It is shown that e-Turbo™ provides additional capabilities not available without this technology. This includes the capability to "dial in" an air flow, EGR rate and exhaust temperature (within limitations) depending on emissions requirements. A comprehensive multi-parameter, model based control system using many sensors and actuators in an overall optimization scheme is needed to take full advantage of this increased capability. Preliminary results of the use of such a control system are demonstrated using a mathematical model of the engine and aftertreatment system. It is shown that control logic and sensor signals can be used to achieve better control of NOx emissions, better regeneration of diesel particulate filter (DPF) with improved response and fuel economy.

#### 7.0 References:

1. John Fairbanks, "Chairman's Remarks", Diesel Engine Emissions Reduction Conference, 1999.
2. R.C. Yu and S.M. Shahed, "Effects of Injection Timing and Exhaust Gas Recirculation on Emissions From a D.I. Diesel Engine", SAE Paper No. 811234.
3. R. Ellinger, K. Meitz and P. Prenninger, AVL List GmbH, S. Salchenegger and W. Branstatter, CDL-ACT Mining University Loeben, "Comparison of CO<sub>2</sub> Emission Levels for IC Engines and Fuel Cell Automotive Propulsion Systems", SAE 2001-01-3751
4. Michael Leavitt, EPA Administrator, Statement to the Press, Utah, August 2004.
5. S.M. Shahed, John Allen and Jerry Artache, "The Development of Electrically Assisted Turbochargers for Diesel Engine Applications", Diesel Engine Emissions Reduction Conference, August 2000
6. S.M. Shahed, "Smart Boosting Systems, e-Turbo and e-Charger, New Frontier?" Diesel Engine Emissions Reduction Conference, August 2001.
7. Markus Schwaderlapp, Knut Habermann and Kurt I. Yapici, "Variable Compression Ratio - A Design Solution for Fuel Economy Concepts", SAE 2002-01-1103