

LBL-10511 (Vol.1)
(DE81030222)

OCEAN THERMAL ENERGY CONVERSION (OTEC)
PROGRAMMATIC ENVIRONMENTAL ANALYSIS

Volume 1

By
M. Dale Sands

January 1980

Work Performed Under Contract No. W-7405-ENG-48

Interstate Electronics Corporation
Anaheim, California

RECEIVED
LAWRENCE
BERKELEY LABORATORY
NOV 13 1981
LIBRARY AND
DOCUMENTS SECTION

TWO-WEEK LOAN COPY

*This is a Library Circulating Copy
which may be borrowed for two weeks.
For a personal retention copy, call
Tech. Info. Division, Ext. 6782*

U.S. Department of Energy



Solar Energy

LBL-10511 v.1
c.2

VOLUME 1

**Ocean Thermal Energy Conversion (OTEC)
Programmatic
Environmental Analysis**

Subcontract Number 4501010

January 1980

OCEAN THERMAL ENERGY CONVERSION PROGRAMMATIC ENVIRONMENTAL ANALYSIS

Principal Investigator and Senior Editor

M. Dale Sands

Chapter Editors

M. Dale Sands (Chapter 1, 3, 4, 6)
S. Mack Sullivan (Chapter 2, 3)
H. Stanley/M. Smookler (Chapter 5)
Matthew Howard (Chapter 7, Appendix C)
Molly Andrews (Appendix A)
Kirk Stoddard (Appendix B)

Contributors

John Donat (Chapter 2, 3, Appendix B)
M.E. Doull (Chapter 2, Appendix B)
Andrew Lissner (Chapter 2, Appendix B)
Elizabeth Obadie (Editorial)
Mike Valenti (Editorial)
Kathy Buckles (Production)
Judith Gagnon (Production)
Shirley Heckelman (Production)

Consultants

Dr. Arthur Barnett, Marine Ecological Consultants, Solana Beach, CA
Dr. James Demenkow, Exeter, R.I.
Dr. Jed Hirota, Aquatic Sciences Corporation, Honolulu, HA

Prepared For:

Marine Science Group
Earth Science Division
Lawrence Berkeley Laboratories
University of California
Berkeley, CA 94720

United States Department of Energy
Division of Solar Technology
Ocean Systems Branch
Washington, D.C. 20545
Contract No. W-7405-ENG-48

by

Oceanic Engineering Operations
INTERSTATE ELECTRONICS CORPORATION
Anaheim, California 92803

Subcontract 450101Q

PREAMBLE

This Environmental Analysis was written during 1979 and reflects the legal situation and policy current at that time. Since its completion, the Matsunaga bill was passed and signed into law as P.L. 96-310, the Ocean Thermal Energy Conversion Research, Development, and Demonstration Act, and the Studds bill was enacted as P.L. 96-320, the Ocean Thermal Energy Conversion Act of 1980.

The proposed action described was based on Department of Energy policy of mid-1979 in which the most probable configuration for an Ocean Thermal Energy Conversion plant was a moored closed-cycle system.

Finally, the reader should be aware that the draft of this document was published and reviewed as the "Ocean Thermal Energy Conversion (OTEC) Draft Programmatic Environmental Assessment" and it has been retitled on advice from the Department of Energy Assistant Secretary for the Environment "Ocean Thermal Energy Conversion (OTEC) Programmatic Environmental Analysis." This report is therefore no longer considered a National Environmental Policy Act compliance document.

EXECUTIVE SUMMARY

This programmatic environmental analysis is an initial assessment of OTEC technology considering development, demonstration and commercialization; it is concluded that the OTEC development program should continue because the development, demonstration, and commercialization on a single-plant deployment basis should not present significant environmental impacts. However, several areas within the OTEC program require further investigation in order to assess the potential for environmental impacts from OTEC operation, particularly in large-scale deployments and in defining alternatives to closed-cycle biofouling control:

- Larger-scale deployments of OTEC clusters or parks require further investigations in order to assess optimal platform siting distances necessary to minimize adverse environmental impacts.
- The deployment and operation of the preoperational platform (OTEC-1) and future demonstration platforms must be carefully monitored to refine environmental assessment predictions, and to provide design modifications which may mitigate or reduce environmental impacts for larger-scale operations. These platforms will provide a valuable opportunity to fully evaluate the intake and discharge configurations, biofouling control methods, and both short-term and long-term environmental effects associated with platform operations.
- Successful development of OTEC technology to use the maximal resource capabilities and to minimize environmental effects will require a concerted environmental management program, encompassing many different disciplines and environmental specialties.

THE PROPOSED ACTION

The Proposed Action considered in this Environmental Analysis (EA) is the development, demonstration, and commercialization of Ocean Thermal Energy Conversion. This EA is programmatic in scope, considering several techno-

logical designs, plant configurations, and power usages; it will be periodically updated as further information is obtained on OTEC technology and environmental factors. This EA considers potential environmental impacts, health and safety, and international, Federal, and state plans and policies.

OTEC uses the temperature differential between warm surface seawater and cold deep ocean water to produce electrical power by means of gas or steam turbines. The minimal temperature difference required is approximately 20°C, thus the usable geographical regions are limited to those where such temperature differentials prevail. The deployment scenario projects that populated island communities will be the first market penetration of OTEC platforms followed by large numbers of moored plants in the Gulf of Mexico and plant-ships producing ammonia or aluminum in the open ocean regions.

This EA considers the closed-cycle and open-cycle OTEC systems. The closed-cycle OTEC system pumps warm seawater through an evaporator where the heat is transferred across a heat exchanger surface to a working fluid (ammonia or Freon™). The vaporized working fluid drives a gas turbine which produces electricity. After passing through the turbine, the vapor is condensed by colder ocean water which is drawn up from the lower ocean. The working fluid is then pumped back into the evaporator for reuse in the same cycle. No fuel in a conventional sense is used. The enclosed working fluid is evaporated and condensed repeatedly by the warm surface and colder deep ocean waters. An OTEC plant has a net energy production efficiency of 3 to 5%. A major problem of the closed cycle is maintaining biofouling below critical levels on the heat exchanger surfaces. Chemical methods in combination with mechanical methods are proposed to control biofouling.

The open-cycle system is similar to the closed-cycle system, except that seawater is used as the working fluid, thereby obviating the need for heat exchanger surfaces and biofouling control. Warm seawater flows into a partially evacuated evaporator where the lowered pressure causes it to boil. The steam, after passing through a turbine, is condensed by colder deep ocean water. Again, no conventional fuel is used. Fresh water is a potential by-product of the open-cycle system.

The greater probability of achieving OTEC performance goals with the closed-cycle system has led to its selection as the baseline power system for initial demonstration. The closed-power cycle may be used for land-based, moored, or grazing plant-ships which produce over 400-MW of power. The open-cycle system is under consideration for possible second-generation application, as warranted by technological developments and analysis. Open-cycle systems will probably be small plants, about 40-MW in size, primarily land-based on island communities, and will produce baseload electrical power and fresh water.

EXISTING ENVIRONMENT

Siting of OTEC plants is geographically restricted between approximately 30° north and 30° south of the equator, where annual surface-to-1,000 m temperature differentials of 20°C prevail. These subtropical-tropical areas are generically characterized as oceanic as opposed to coastal or neritic. Oceanic ecosystems are located in stable environments and are responsive to stress. The economic environments range from island communities totally dependent on foreign imported oil to the Gulf coast of the United States with reserves of coal, gas and oil.

POTENTIAL ENVIRONMENTAL IMPACTS

The installation and operation of OTEC plants may potentially affect the terrestrial and marine environment, as well as the atmosphere. The potential environmental impacts center on the marine ecosystem because it is the environment most influenced by OTEC operation. Atmospheric effects include climatic disturbances due to carbon dioxide releases and sea-surface temperature cooling. Measurable atmospheric effects are not anticipated from the deployment of single-platform installations; however, the carbon dioxide releases from large-scale regional deployments of OTEC plants could combine with other man-induced carbon dioxide releases to result in measurable climatic alterations and further investigations are warranted.

Land effects will result from the construction of plants and transmission cable entry points. Further site selection studies are necessary to collect terrestrial ecology data to assess these impacts.

The environmental issues that may affect the oceanic environment resulting from OTEC development include:

- Biota attraction
- Organism impingement/entrainment
- Ocean water redistribution
- Biocide release
- Industrial effluent discharge
- Protective hull coatings release
- Trace element release
- Working fluid release
- Sanitation discharge
- Mooring and cable implantation

OTEC platforms will provide food and protection to macrozooplankton, micronekton, and nekton. The presence of platforms will establish new communities with larger biomass abundances than those observed prior to OTEC deployment. These additional organisms will be exposed to the effects associated with routine plant operation, such as organism impingement and entrainment, trace constituent release, and risk of nonroutine events such as spills.

The principal marine ecosystem impacts are associated with the seawater intakes and the discharge plume. Large volumes of warm and cold seawater will be withdrawn from the ocean, thus impinging and/or entraining pelagic organisms. The primary factors which determine impingement and entrainment rates are intake flow rates and population densities at the intake depths. Entrainment mortality may approach 100% as a result of mechanical abuse and exposure to large pressure and temperature differentials. Micronekton and nekton are likely to be impinged and will have a mortality rate of nearly 100%. Single-plant installations will affect only localized areas around the plant by reducing standing stocks; however, large-scale deployments may alter the entire regional ecosystem.

OTEC plants will redistribute large quantities of ocean waters which will alter water column thermal structures, salinity gradients, and concentrations of dissolved gases, nutrients, turbidity and trace constituents. The most serious effect may result from bringing nutrient-rich deep ocean waters to the surface, which, if discharged in the photic zone, will stimulate primary production in the receiving waters. However, discharge configurations may mitigate or reduce this effect. Large-scale OTEC deployments may influence regional primary production, particularly in the event of severe storms where upper surface waters would be well-mixed. The combined flow of several OTEC plants may form small-scale "water masses" identifiable downstream of the plants.

Biocides used to prevent biofouling on the heat exchanger surfaces of closed-cycle OTEC plants will be released with the discharged waters and may be irritating or toxic to marine organisms.

RISK OF CREDIBLE ACCIDENTS

Crew members of OTEC plants, the adjacent population, and communities served by OTEC plants will be exposed to potential accidents and power failures. Large volumes of the working fluid (ammonia or Freon™) will be stored onboard and present certain health hazards should a collision or large leak occur. Concentrated ammonia is an irritating and corrosive compound which can damage mucous membranes and inhibit respiration of humans and animals. Ammonia combined with chlorine is an explosive mixture. Freon™, boils at ambient seawater temperatures and may form toxic phosgene gas. Offshore ammonia plant-ships will present risks to the crew, since production of the explosive ammonium nitrate is a potential intermediary compound. The hazards which exist for aluminum production include the use of fluorine-producing gases and other hazards specific to the manufacturing processes.

The development of a health risk assessment model is necessary on a region-to-region basis to fully assess the potential of both man-made and nature-induced accidents. Ship traffic around OTEC platforms must be carefully monitored to minimize collision potentials.

INTERNATIONAL, FEDERAL AND STATE PLANS AND POLICIES

OTEC platforms will operate in three jurisdictions: (1) the territorial seas which fall under the jurisdiction of the coastal states; (2) the exclusive economic resource zone, which falls under the administration of the Federal government, and, (3) the high seas which are internationally regulated. Thus, several legal, health, and safety plans and policies come into focus concerning plant licensing, siting, monitoring, and operation.

No legal framework is presently applicable to OTEC platforms. Internationally, OTEC will likely fall under the "Reasonable Use" theory and no regulations will be developed. Alternatively, existing legislation may be amended to include OTEC platforms. At the Federal level, there is no single legal route which applies to siting, licensing, or regulating OTEC platforms; responsibilities and authorities are spread across several governmental agencies. One solution may be the designation of a single lead Federal agency. Such an approach has been offered in proposed legislation (Studds Bill). State issues are similarly not clear. Studies are underway to resolve relationships between Federal regulatory laws, civil and criminal laws, maritime laws and state laws.

Crew health and safety is a crucial aspect of OTEC operation in the marine environment. It too is under a state of flux with the jurisdiction for marine safety given to the U.S. Coast Guard in the Department of Transportation and process safety falling under the Occupational Safety and Health Administration of the Department of Labor. Several aspects of OTEC operation are not currently regulated and will require modification of existing regulations or creation of new laws. Actions in process would bring all responsibilities under Coast Guard jurisdiction. Responsibilities for compliance with U.S. Coast Guard regulations apply to all vessels owned or operated by U.S. companies. The Department of Energy will require the preparation of a Safety Analysis Report that identifies the hazards associated with operation and describes an approach to eliminate or control the hazards.

ALTERNATIVES

The alternatives considered are within the OTEC technology and include the choice of power cycle (open or closed), platform configuration (land-based, moored, or plant-ship), discharge design (mixed or separate releases), and intended power use (baseload electricity or at-sea production of ammonia and aluminum).

RECOMMENDATIONS

In preparing this initial Environmental Analysis of OTEC technology, several areas were defined which require further study; the recommendations include:

- Large-scale commercialization of OTEC parks within a region (e.g., eastern Gulf of Mexico) may adversely affect the region's ecosystem and have large-scale impacts. Further studies are required to determine the spacing requirements of OTEC platforms in order to minimize environmental impacts.
- Single-platform deployments up to 400-MW potentially offer advantages and minimal environmental risks. However, future impact study efforts should examine site- and platform-specific effects with environmental impact statements for demonstration-size platforms. These impact statements must be completed in advance of construction to examine design options that mitigate or reduce expected environmental impacts.
- A thorough report should be prepared that would describe the viable OTEC power cycles and platform options available, as well as discount those options not deemed feasible for early design efforts.
- An OTEC program deployment scenario should be prepared to consider both the open-cycle and closed-cycle systems, different platform design configurations, and various power uses. This scenario would then serve as the basis for future OTEC program plans.

- The open-cycle OTEC system, relegated to small-sized island plants, presents some advantages over the closed-cycle system, but both require a detailed environmental assessment to fully evaluate their environmental suitability.
- The use of Freon™ as a working fluid in the closed-cycle system presents undue public health hazards and risks.
- Consideration should be given to the production of shore-based aluminum plants rather than at-sea production, thereby limiting handling of bauxite or alumina.
- Complete platform health and safety plans should be developed for land-based, moored, and grazing platform configurations. This would include the preparation of a Health Risk Assessment model to evaluate various platform designs and siting locations for overall risk of credible accidents.
- An OTEC site selection tiering criterion should be developed and applied to candidate OTEC regions in order to:
 - Select optimal OTEC sites based upon engineering and environmental data requirements.
 - Group optimal locations generically by predominant features and perform environmental baseline studies that may be extrapolated to other regions. Both spatial and temporal variability of the sites must be evaluated.
 - Consider ocean space designation studies for specific types and sizes of OTEC platforms.
- The inherent disadvantage of using chlorine as a biofouling control agent requires additional research to fully evaluate potential

environmental effects. In addition, efforts should continue to select an environmentally preferable candidate for biofouling control.

- Careful examination of present coastal power plant chlorination practices should be made for plants located in subtropical or tropical environments to determine potential impacts applicable to OTEC plants.
- Chlorine-seawater research should be continued in order to identify potential residual oxidants that may be formed.
- Continue bioassay and toxicity studies to determine acute and chronic effects of potential OTEC plant releases.
- Preoperational and demonstration platform environmental impact studies should be performed to gain information that may be extrapolated to larger-scale platforms. Platform designs for intakes, discharges and chlorine releases should be altered to determine differences in environmental effects.
- Basic food chain studies should be conducted to determine the effects of organism impingement and entrainment from OTEC plant operation.
- Terrestrial ecology surveys should be initiated for candidate land-based locations.
- Climatic influences that may result from large scale OTEC deployments must be evaluated further.
- The development of large-scale, wide-basin models to examine physical impacts of OTEC plant operation should be continued; longer-term goals will call for the preparation of ecological models.

- A mock licensing process at the Federal and International level should be initiated to determine the involved agencies and the applicable regulations.
- Periodically reissue an updated programmatic environmental assessment to reflect recently obtained information.

ORGANIZATION OF THE ENVIRONMENTAL ASSESSMENT

This Environmental Analysis contains several chapters:

- Chapter 1 is a description of the Proposed Action.
- Chapter 2 characterizes the Existing Environment.
- Chapter 3 provides an assessment of the Potential Environmental Consequences of the Proposed Action.
- Chapter 4 considers the Risk of Credible Accidents and mitigating measures to reduce these risks.
- Chapter 5 describes the International, Federal and State Plans and Policies that the Proposed Action will encompass.
- Chapter 6 presents the Alternatives to the Proposed Action.
- Chapter 7 is a glossary of scientific and technical terms, a list of abbreviations, and references.

Three appendices are included:

- Appendix A is a synthesis of previously completed OTEC deployment studies which describe a projected commercialization scenario.
- Appendix B is a compendium of oceanographic data for potential OTEC resource areas.
- Appendix C is a brief description of the methods or calculations used in the EA.

CONTENTS

<u>Section</u>	<u>Title</u>	<u>Page</u>
	PREAMBLE	iii
	EXECUTIVE SUMMARY	iv
1	THE PROPOSED ACTION	1-1
1.1	PROGRAM OBJECTIVES	1-2
1.2	TECHNOLOGY DESCRIPTION	1-3
1.2.1	Deployment Scenario	1-3
1.2.2	Environmentally Significant Design Components	1-7
1.3	OTEC PLATFORM SITING CONSIDERATIONS	1-28
1.3.1	Minimum Siting Criteria	1-29
1.3.2	Economic Feasibility	1-29
1.3.3	Social Issues	1-30
1.3.4	Potential Environmental Consequences	1-30
2	THE EXISTING ENVIRONMENT	2-1
2.1	GEOLOGY	2-1
2.1.1	Data Requirements	2-1
2.1.2	Description	2-1
2.2	PHYSICAL OCEANOGRAPHY	2-2
2.2.1	Data Requirements	2-2
2.2.2	Description	2-2
2.3	CHEMICAL OCEANOGRAPHY	2-9
2.3.1	Data Requirements	2-9
2.3.2	Description	2-9
2.4	BIOLOGICAL OCEANOGRAPHY	2-11
2.4.1	Data Requirements	2-11
2.4.2	Data Description	2-11
2.5	ECONOMIC PROFILES	2-20
2.5.1	Data Requirements	2-20
2.5.2	Description	2-20
2.6	OTEC INDUSTRIAL FACILITIES	2-30
2.6.1	Data Requirements	2-30
2.6.2	Description	2-31
3	POTENTIAL ENVIRONMENTAL IMPACTS	3-1
3.1	ATMOSPHERIC EFFECTS	3-1
3.1.1	Industrial Releases	3-1
3.1.2	Climatic Effects	3-2
3.2	LAND IMPACT ISSUES	3-6
3.2.1	Coastal Zone	3-6
3.2.2	Discharges	3-6
3.3	WATER ISSUES	3-7
3.3.1	Approach	3-8
3.3.2	Platform Effects	3-8
3.3.3	Warm and Cold Water Withdrawal	3-12
3.3.4	Discharges	3-18

CONTENTS (continued)

<u>Section</u>	<u>Title</u>	<u>Page</u>
3.4	ECONOMIC ISSUES	3-33
	3.4.1 Baseload Electricity	3-33
	3.4.2 Plant-Ship Products	3-36
3.5	OTEC ENVIRONMENTAL STUDIES	3-36
	3.5.1 Status	3-36
	3.5.2 Future Requirements	3-38
3.6	UNAVOIDABLE ADVERSE EFFECTS	3-41
	3.6.1 Use of Energy and Resources	3-41
	3.6.2 Trace Constituent Releases	3-41
	3.6.3 Organism Impingement and Entrainment	3-41
	3.6.4 Redistribution of Ocean Properties	3-42
	3.6.5 Exposure to Accidents	3-42
3.7	RELATIONSHIP BETWEEN SHORT-TERM USE AND LONG-TERM PRODUCTIVITY	3-43
3.8	IRREVERSIBLE AND IRRETRIEVABLE RESOURCE COMMITMENT	3-43
4	RISK OF CREDIBLE ACCIDENTS	4-1
4.1	CONSIDERATIONS FOR A RISK ASSESSMENT MODEL	4-1
4.2	POTENTIAL EMERGENCY SITUATIONS	4-3
	4.2.1 Man Made	4-3
	4.2.2 Acts of Nature	4-4
4.3	MITIGATING MEASURES	4-5
	4.3.1 Risk Assessment Studies	4-5
	4.3.2 OTEC Traffic	4-5
	4.3.3 Spill Contingency Plans	4-5
5	RELATIONSHIP TO INTERNATIONAL, FEDERAL, AND STATE PLANS AND POLICIES	5-1
5.1	LEGAL CONSIDERATIONS	5-1
	5.1.1 Jurisdictional Limits	5-1
	5.1.2 State Issues	5-5
	5.1.3 Federal Issues	5-8
	5.1.4 International Issues	5-12
5.2	HEALTH AND SAFETY REGULATIONS	5-15
	5.2.1 General Safety Considerations	5-16
	5.2.2 Platform Considerations	5-18
	5.2.3 Personnel and Process System Safety	5-21
	5.2.4 International Safety Concerns	5-31
6	ALTERNATIVES	6-1
6.1	POWER CYCLE	6-1
6.2	PLATFORM CONFIGURATION	6-3
6.3	DISCHARGE	6-3
6.4	POWER USE	6-4

CONTENTS (continued)

<u>Section</u>	<u>Title</u>	<u>Page</u>
7	GLOSSARY, ABBREVIATIONS, AND REFERENCES	7-1
	GLOSSARY	7-1
	ABBREVIATIONS	7-21
	REFERENCES	7-25
 APPENDICES		
A	DEPLOYMENT SCENARIO	A-1
B	OTEC RESOURCE REGIONAL CHARACTERIZATION	B-1
C	IMPACT AND RELATED CALCULATIONS	C-1

ILLUSTRATIONS

<u>Number</u>	<u>Title</u>	<u>Page</u>
1-1	OTEC Systems Development	1-6
1-2	Gulf of Mexico Moored OTEC Resource Area	1-8
1-3	Example of OTEC Sump that Accomodates VerticalTraveling Screens	1-13
1-4	Schematic Diagram of Closed-Cycle OTEC Power System	1-16
1-5	Tube-in-Shell Heat Exchanger	1-17
1-6	One Possible Plate-Type Heat Exchanger	1-18
1-7	Estimated Relationship between Thickness of Fouling Deposit and the Thermal Resistance, R_f	1-21
1-8	General System Layout of an Open-Cycle OTEC Plant	1-27
2-1	World Thermal Resource	2-4
2-2	Large-Scale Circulation Patterns	2-7
2-3	Percent Population Distribution by District (Hawaii)	2-22
2-4	Electrical Power Grid--Hawaii	2-25
2-5	Electrical Power Grid--Puerto Rico	2-29
2-6	Ammonia and Aluminum Plant-Ship Resources	2-32
3-1	Degradation Processes for Chlorine in Saline Waters	3-27
3-2	Disappearance with Time of Residual Oxidants in Chlorinated Seawater as a Function of Exposure to Sunlight	3-28
3-3	The Decision Key to the "Main Sequence" Categories of Environmental Studies	3-39
5-1	Economic Resource Zone for OTEC Regimes	5-3
6-1	OTEC Alternatives	6-2

CONTENTS (continued)

TABLES

<u>Number</u>	<u>Title</u>	<u>Page</u>
1-1	OTEC Deployment Scenario	1-6
1-2	Summary of Toxic Constituent Types Used in Antifouling Coatings	1-11
1-3	Intake and Discharge Flow Summary	1-11
2-1	Physical Oceanographic Features of Potential OTEC Areas	2-3
2-2	Chemical Characterization of Potential OTEC Areas	2-10
2-3	Biological Characterization of Potential OTEC Areas	2-13
2-4	Micronekton Biomass (Wet Weight) in the Tropical-Subtropical Pacific	2-15
2-5	Endangered and Threatened Species of the OTEC Resource Area	2-17
3-1	Potential Biological Effects Resulting from OTEC Deployment and Operation	3-9
3-2	Estimated Biomass (Wet Weight) Impinged Daily by Various Sizes and Numbers of OTEC Plants	3-15
3-3	Estimated Biomass Entrained Daily by Various Sizes and Number of OTEC Plants	3-17
3-4	Discharge Water Plume Modeling Results	3-20
3-5	Enhanced Primary Production Due to the Discharge of Nutrient-Enriched Water in a One-Meter Long and 60-Meter-Deep Portion Plume	3-24
3-6	Centerline Dilution and Chlorine Concentration Downstream of a Closed-Cycle 40- and 400-MW OTEC Plant	3-30
3-7	Oxygen Utilization Due to Biomass Degradation	3-34
5-1	Status of State Coastal Zone Management Programs in OTEC Regions	5-7
5-2	Federal Agencies Involved in OTEC Licensing	5-9
5-3	Potential Hazards Summary	5-23
5-4	Safe Location of Ammonia Containers	5-24



Chapter 1

THE PROPOSED ACTION

The Proposed Action in this Environmental Analysis (EA) is the development, demonstration, and commercial operation of large-scale Ocean Thermal Energy Conversion (OTEC) plants for the ultimate use of providing baseload electricity and the production of energy-intensive products, ammonia and aluminum. This EA is prepared in compliance with the National Environmental Policy Act of 1969 (NEPA) and considers the reasonably foreseeable environmental consequences inherent in OTEC development, demonstration, and commercialization. The EA is programmatic in that it considers plants of several different configurations, designs, and operations to be sited in tropical and subtropical waters by the year 2020.

OTEC, ocean currents, salinity gradients, and wave energy are the four programs under study by the Ocean Systems Branch of the U.S. Department of Energy that have the potential for providing energy from non-depletable ocean resources. OTEC uses the temperature differential between warm surface seawater and cold deep ocean water to produce electrical power by means of gas or steam turbines. The minimal operational temperature difference required is approximately 20°C, thus limiting the usable geographical regions.

OTEC commercialization will progress from small (1- to 5-MW) preoperational test platforms, to intermediate (10- to 40-MW) modular demonstration platforms, to large-scale, commercial platforms (100- to 400-MW). This development will encompass both closed- and open-cycles, and involve land-based, moored and plant-ship configurations.

There are a large number of different design components for OTEC plants. This EA examines only those components that may have environmental significance or potential for impact and considers the siting of both open- and closed-cycle platforms. A single, moored, 40-MW open-cycle plant is evaluated

for potential impacts, along with 40- and 400-MW closed-cycle plants. A cluster of OTEC plants (eight to nine 400-MW plants) and an OTEC park (group of clusters) are also considered for potential environmental impacts.

1.1 PROGRAM OBJECTIVES

The OTEC program goal of the Department of Energy (DOE) is to demonstrate the technological, economic, and environmental feasibility of an OTEC power plant (DOE, 1979a). The principal application of OTEC technology is to produce electrical power and/or energy-intensive products commercially by the turn of the century.

To accomplish this goal, the program is subdivided into interrelated subprograms: strategy and definition planning, engineering development and demonstration, and technology development. These OTEC subprograms have been designed to accomplish a series of related objectives (DOE, 1979a):

- Demonstrate the operation and performance of an OTEC power plant with a sufficiently advanced heat exchanger design to be economically feasible;
- Develop heat exchanger concepts through research and development, bench-scale (core) tests, ocean tests of large components, and operation of pilot power plants on large floating test facilities;
- Perform mission analysis and hull configuration analysis for specific applications to define demonstration and commercial configurations;
- Determine the impact of biofouling and corrosion on long-term performance capability of OTEC options;
- Define test site environmental characteristics, such as temperature and current profiles; wind, wave, and current forces; biota; biological community composition; and trophic structure;

- Assess the possible physical oceanographic, climatic, biological, and ecological impacts of OTEC;
- Evaluate industrial processes yielding energy-intensive products to determine performance, reliability, and environmental impacts in an ocean environment; and
- Adapt and develop the technology of submarine electrical energy transmission.

The OTEC Systems Development Schedule to accomplish these goals is illustrated to 1986 in Figure 1-1.

1.2 TECHNOLOGY DESCRIPTION

1.2.1 Deployment Scenario

OTEC deployment scenarios have been prepared by Washom et al. (1977), General Electric (1977), Francis (1977), and Jacobsen and Manley (1979). These studies were reviewed and an estimate was projected of the types and numbers of plants to be deployed by the years 1995 to 2020. The complete deployment scenario is presented in Appendix A. The summary of the scenario is presented for baseload electricity and industrial plant-ships in the following sections.

1.2.1.1 Baseload Electricity Scenario - This deployment scenario is based on the study by Jacobsen and Manley (1979).

The island markets of Hawaii, Puerto Rico, and Guam are expected to be penetrated in the thermal resource areas adjacent to the population centers and electric grid entry points. After the establishment of demonstration and operational platforms in these island communities, large-scale commercialization will follow.

OTEC SYSTEMS DEVELOPMENT

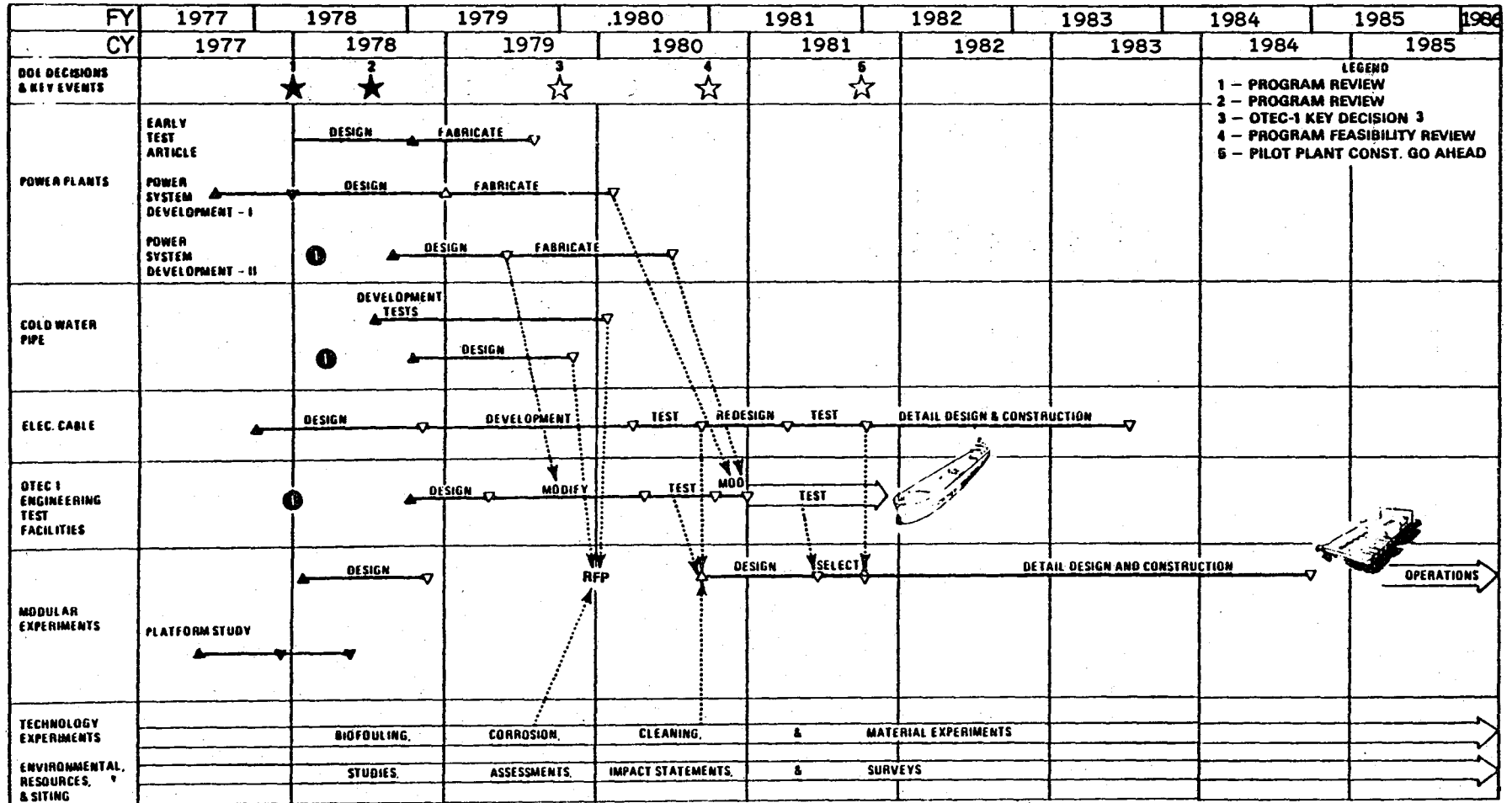

1-4

REV. 10/19/79

0015-702-26

Figure 1-1. OTEC Systems Development
Source: DOE, 1979b

Jacobsen and Manley suggest that the island deployment be accomplished in three phases:

- Phase 1 - Two 10-MW pilot plants,
- Phase 2 - One 50- to 100-MW precommercial pilot plant,
- Phase 3 - Combined installed capacity in 1995 of 500- to 4,000-MW.

Through the demonstration and development phase it is projected that a total of eight modular 40- to 100-MW plants will be operational in Hawaii and Puerto Rico by 1995. By 2020, the number of land-based or moored plants will increase to 12 in Hawaii and 10 in Puerto Rico, with 4 plants established in Guam or other U.S. possessions or territories. Because of the advantage of fresh water production with the open cycle, it is expected that a portion of the plants in Hawaii, Puerto Rico, and Guam will be open-cycle. A tabular presentation of the distribution of OTEC plants appears in Table 1-1.

The Gulf of Mexico is a major location within U.S. waters for several moored OTEC platforms. This large-scale cluster type entry to the Southeast Continental U.S. grid is predicated upon the presence of an established island capacity of 500- to 4,000-MW by years 1995 to 2000. The total projected power production from the Gulf of Mexico by the year 2020 ranges from 22- to 72-GW (a gigawatt is equal to 1,000 megawatts). The range is due to the various levels of Federal incentives (Jacobsen and Manley, 1979). The moderate incentive, considered in this EA, is based on the production of 58-GW from the Gulf of Mexico by the year 2020. This level of power production will require one hundred forty-six 400-MW plants, or approximately 18 clusters.

The specific locations of these plants within the thermal resource region is difficult, if not impossible, to determine, because many complex issues are to be considered. However, some limitations do exist. The moored platforms, due to mooring technology, are not anticipated to be sited in water deeper than 2,150 m. Land-based and moored plants will be located as near as possible to shore, in suitable deep ocean waters.

TABLE 1-1. OTEC DEPLOYMENT SCENARIO SUMMARY

Region	Type of Plant	Unit Plant Size (MW)	1995		2020	
			No. Plants	Total Output (GW)	No. Plants	Total Output (GW)
Gulf of Mexico	Moored--Closed Cycle	400	--	--	146	58
Puerto Rico	Moored--Closed Cycle	100	2	0.2	4	0.4
	Moored--Closed Cycle	400	--	--	2	0.8
	Land-Based--Open Cycle	40	1	0.04	2	0.08
	Land-Based--Closed Cycle	40	<u>1</u>	<u>0.04</u>	<u>2</u>	<u>0.08</u>
	TOTAL--PUERTO RICO		4	0.28	10	1.36
Hawaii	Moored--Closed Cycle	100	1	0.1	2	0.2
	Moored--Closed Cycle	400	-	-	2	0.8
	Land-Based-Open Cycle	40	1	0.04	3	0.12
	Land-Based--Closed Cycle	40	<u>2</u>	<u>0.08</u>	<u>5</u>	<u>0.2</u>
	TOTAL HAWAII		4	0.22	12	1.32
Guam	Land-Based--Open Cycle	40	-	-	2	0.08
	Land-Based--Closed Cycle	40	-	-	2	<u>0.08</u>
	TOTAL--GUAM				4	0.16
AMMONIA PLANT-SHIP						
Gulf of Mexico	Plant-ship--Closed Cycle	500	4	2.0	29	14.5
South Atlantic	Plant-ship--Closed Cycle	500	4	<u>2.0</u>	<u>29</u>	<u>14.5</u>
	TOTAL PLANT-SHIPS		8	4.0	58	29.0
ALUMINUM PLANT-SHIP						
Gulf of Mexico	Plant-ship--Closed Cycle	400	-	-	15	6
South Atlantic	Plant-ship--Closed Cycle	400	-	-	25	10
South Pacific	Plant-ship--Closed Cycle	400	-	-	<u>25</u>	<u>10</u>
	TOTAL PLANT-SHIPS				65	26

The region of the Gulf of Mexico where a park of 146 moored plants could be located is illustrated in Figure 1-2. It is important to note that these regions represent the total area of the Gulf of Mexico that has at least an annual average delta t of 20°C, is within the depth limitations of mooring technology, and is within the U.S. Economic Resource Zone (ERZ). The area where the delta t is 20°C each month is also shown.

1.2.1.2 Plant-Ship Scenario - The plant-ship scenario selected is based on the General Electric (1977) study. General Electric estimated the ammonia demand to increase 3% annually; to accommodate the increase, eight 500-MW ammonia plant-ships would be needed by 1995. By the year 2000, ten more plant-ships would be required with two additional plant-ships required every year thereafter. This addition, after the turn of the century, is regarded as a conservative estimate by General Electric, and means that fifty-eight plant-ships would be operational by the year 2020.

General Electric projected a 4.9% annual growth for aluminum; approximately one hundred and thirty-four 400-MW plant-ships would be required by 2020 to satisfy the demand, provided that all new aluminum production occurs at sea after the year 2000. However, recent estimates of future demands would decrease the requirements to sixty-five 400-MW plant-ships, each producing 247,000 tons per year (Markel, 1979). Bauxite reserves for aluminum production are primarily in Australia, Jamaica, and South America, with lesser quantities reported in Asia and West Africa (Washom et al., 1977). Thus, the major plant-ship locations will be close to the bauxite resources in the South Atlantic, and the South Pacific, with others in the Gulf of Mexico.

A tabular summary of plant-ship distribution is presented in Table 1-1.

1.2.2 Environmentally Significant Design Components

Moored and land-based OTEC plants may employ either the open- or closed-cycle. Plant-ships will use the closed-cycle for power production. The two OTEC platforms recently constructed (Mini-OTEC and OTEC-1) employ the closed-cycle and are moored.

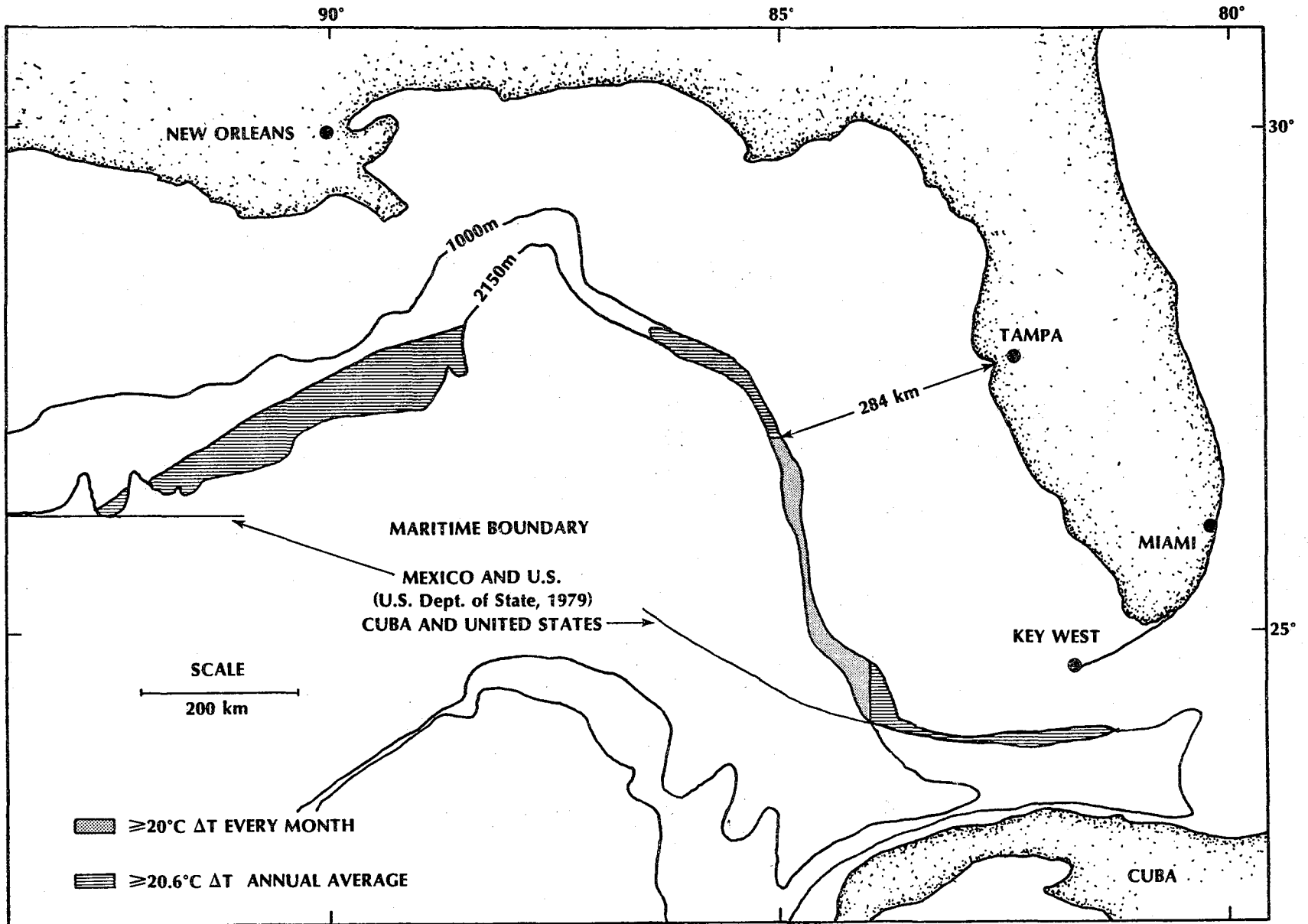

Figure 1-2. Gulf of Mexico Moored OTEC Resource Area
 Source: Modified from Molinari and Festa, 1978;
 U.S. Department of State, 1979

There are several features which interact with the environment, common to either the open- or closed-cycle system. These features include:

- Release of protective hull coatings;
- Intake of warm surface and cold deep ocean waters;
- Discharge of water through an outfall directed horizontally, vertically, or a combination thereof at, near, or in the thermocline.

Other environmentally significant features of a closed power cycle include:

- Release of trace metals from the power system;
- Release of biofouling control chemicals (e.g., chlorine);
- Intermittent release of microfouling materials by mechanical scrubbing of heat exchangers;
- Potential release of working fluids (either continuous leaks or large spills).

The significant features of the open-cycle, apart from the inherent features listed above, include:

- Release of dissolved gases;
- Release of degassed ocean waters;
- Release of high salinity waters.

1.2.2.1 Protective Hull Coatings - OTEC power modules will be located on specifically designed platforms or hulls capable of withstanding the stresses of ocean water movement, as well as the induced movement of water through the system. To retard the buildup of macrofouling on hull surfaces, which adds

additional weight and drag to the platform, protective hull coatings will be applied. Toxic coatings are not practical for heat exchanger surfaces because their thickness interferes with heat transfer. Protective hull coatings may incorporate heavy metal salts, organic compounds, or thermoplastic paints as their toxic constituent.

The advantages and disadvantages of the various toxic constituents are summarized in Table 1-2. Coatings consist of a matrix containing a soluble toxic constituent: either the toxic constituent diffuses out of the matrix, or the entire coating gradually erodes to expose a fresh surface. Salts of copper, mercury and zinc are often used. However, toxic metal salts require a protective primer coating when applied to metallic structures. Another consideration, with regard to heavy metal salts, is the Federal government restriction of some paints (e.g., those based with mercury) because of potential environmental effects.

Toxic organic compounds such as organotin, organolead, and organotin fluorides are generally more effective protective coatings than heavy metal salts. The biocidal properties of these compounds have been demonstrated in the paper industry and in antifouling coverings (Luijten, 1972). Montemarano and Dyckman (1973) and Castelli et al. (1975) reported that organometallic coatings have longer periods of effectiveness, due primarily to the constant rate of leaching. Organometallic coatings leach approximately one order of magnitude slower than heavy metal salts (Montemarano and Dyckman, 1973); no protective primer coats are needed with organometallic coatings.

Thermoplastic coatings have been used as protective hull coatings for up to four years on naval vessels.

1.2.2.2 Warm and Cold Water Intakes

- a. Volumes - A single large pipe or several pipes will extend from the platform to the cold water resource. The pipes will be approximately 1,000 m long and have a diameter up to 30 m. The cold water pipe (CWP) may be constructed of concrete, steel, fiber glass, polyethylene or nylon fiber neoprene. The flows for plants of 40-, 100- and 400-MW size are listed in Table 1-3.

TABLE 1-2. SUMMARY OF TOXIC CONSTITUENT TYPES USED IN ANTIFOULING COATINGS

TYPE OF TOXIN	ADVANTAGES	DISADVANTAGES	LONGEVITY
Inorganic (based on heavy metals)	Most widely used method	Heavy metals may present pollution problems	Indefinite shiplife
Insoluble matrix (vinyls, hot plastics, epoxy)	Hard, durable surface	Requires high toxic constituent loading; leaching rate variable	6-18 months
Soluble matrix (resins, coal tar pitch)	New toxic surface continually exposed	Requires thick coating; matrix erosion highly variable	6-18 months
Organic (based on organometallics)	No undercoating needed	Toxic constituent is heat labile	Indefinite
Vinyls, teflon and other plastics	Hard, durable surfaces	Many toxic constituent and matrices in developmental stages	Vinyls 6-18 months, others undetermined

Source: Lockheed Center for Marine Research, 1978.

TABLE 1-3. INTAKE AND MIXED DISCHARGE FLOW SUMMARY ($m^3 \text{ sec}^{-1}$)

DISCHARGE	OPEN-CYCLE 40-MW (1)	CLOSED-CYCLE		
		40-MW (2)	100-MW (3)	400-MW (3)
Warm	209	203	340	1356
Cold	159	188	307	1229
Mixed Discharge	368	391	647	2585

(1) Watt et al., 1977

(2) TRW, 1979

(3) Mean of Waid (1979) and TRW (1979) designs

The warm water intake will withdraw water from the top 20 to 30 m of the water column. The intake may be either single or multiple. Vertical intakes often employ velocity caps that produce a horizontal flow field that can be more readily sensed and avoided by fish than a vertical flow (Hansen 1978). The use of velocity caps at coastal generating stations has reduced entrainment rates (Weight, 1958).

- b. Screens - The large volumes of water withdrawn at the warm and cold water intakes of an OTEC plant must be screened to prevent the intake of materials which could clog the heat exchangers. Most conventional power plants employ bars and vertical traveling screens at their intakes. The tops of these screens are out of the water, where they can be cleaned and serviced. The OTEC configuration requires a different approach, because plants will have intakes too deeply submerged for normal screen cleaning. Sumps located between the warm and cold water intakes and the heat exchangers are proposed (Thomas, 1979). These sumps would provide an air-water interface where conventional screening could be used (Figure 1-3).

The recent literature on OTEC related screening technology includes papers by Nath et al., (1977), and Thomas (1979). These investigators described three basic types of intake screens applicable to OTEC: (1) static, (2) traveling, and (3) bar screens. Static screens are usually fixed wire-mesh screens. Traveling screens are a series of screens oriented perpendicular to the water flow, so that the water passes through the ascending or ascending and descending screen panels. The standard range of mesh sizes for static and traveling screens is 0.95 to 1.3 cm (Hansen, 1978). Screens are made of monel wire, with sacrificial anodes or induced current for corrosion protection.

Hansen (1978) made annual cost computations for through-flow and dual-flow vertical traveling screens based on a 100-MW OTEC plant with warm and cold water flows of $425 \text{ m}^3 \text{ sec}^{-1}$ each. At all intake depths, the principle components of the total cost were the initial cost, head loss, and operational maintenance costs. The most economical screen width for traveling screens is 3 m and total cost is optimized at an intake velocity of 0.46 m sec^{-1} (Hansen, 1978).

A bar screen consists of vertical parallel bars positioned over the intake. The principle function of the bar screen is to prevent passage of large objects which may damage the static or traveling screens.

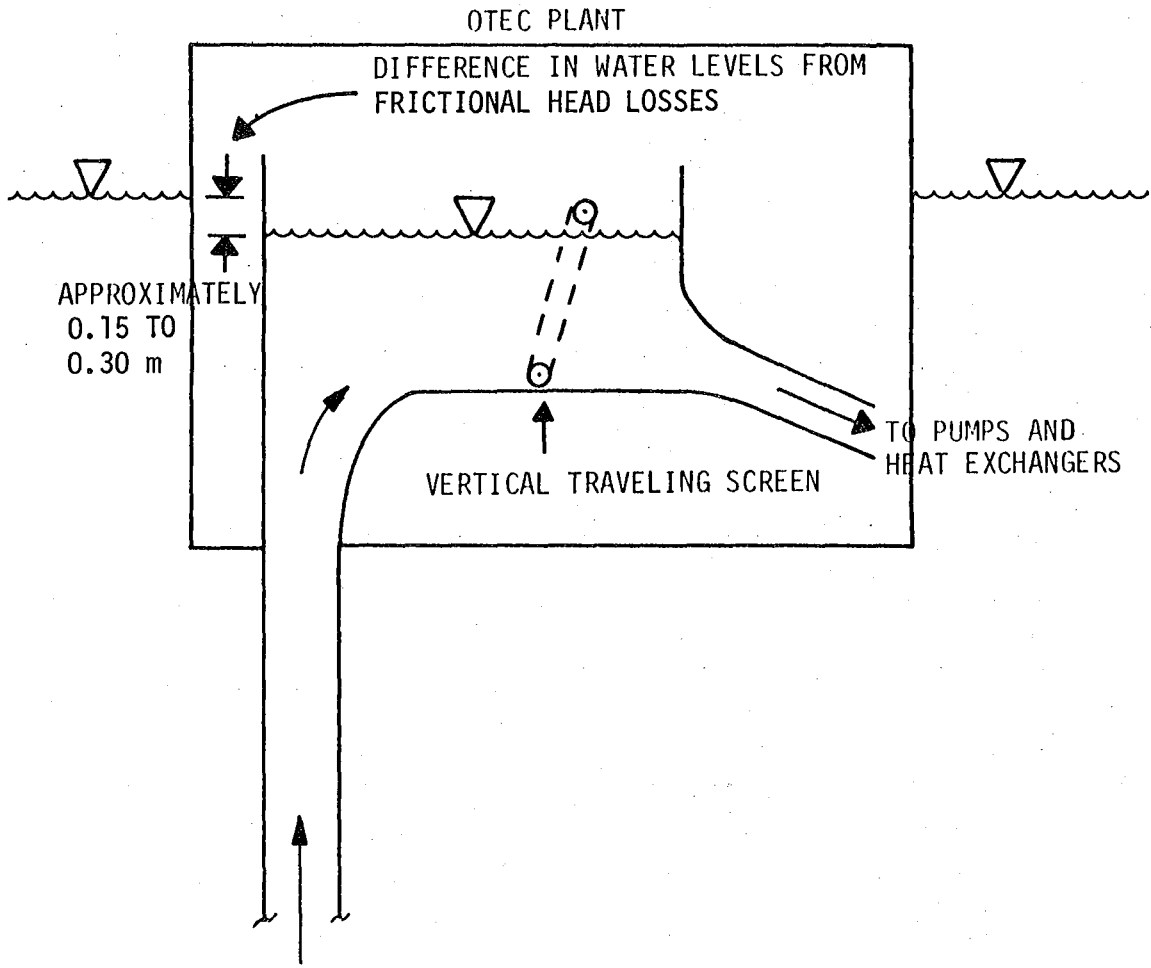

TWO POSSIBLE INTAKE STRUCTURES

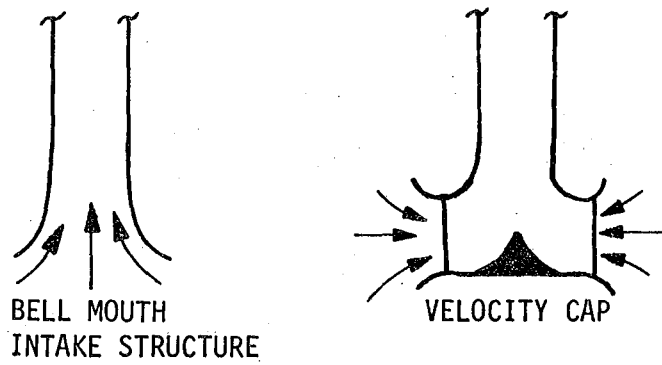

Figure 1-3. Example of OTEC Sump that Accommodates Vertical Traveling Screens
Source: Hansen, 1978

Coastal power plants normally use 8.9 cm by 1.3 cm flat steel bars with 7.6 to 10.2 cm clear openings. If heavy trash loads are anticipated, a traversing rake or brush assembly is used for regular cleaning.

Static screen designs will be used at the warm water intake and at the cold water sump of the preoperational OTEC platform (OTEC-1), with clear openings of 1.59 mm by 76 mm.

1.2.2.3 Discharge Configuration

- a. Warm/Cold Water - Several different discharge configurations have been considered for OTEC platforms, including a mix of cold and warm water, separate releases, and horizontal or vertical releases. In addition, several different depths for release have been proposed, ranging from the surface to 140 m. Mixing the waters serves to dilute the nutrient rich deepwater with the nutrient depleted surface waters and gives the discharged water mass a deeper stabilization depth in the water column. The vertical discharge will inject the waters deeper into the water column than the horizontal release.

Mixed discharge flows typical of 40-MW open- and closed-cycle OTEC platforms are listed in Table 1-3, along with flows for a 100- and 400-MW closed-cycle platform.

- b. Other Discharges - OTEC platforms, like other oceangoing vessels, will discharge municipal wastewater. Depending on the product produced and manufacturing process, industrial wastewater will also be released. While it is not possible to predict the discharge products, it is certain that plant-ships will have to satisfy the Environmental Protection Agency National Pollutant Discharge Elimination System permit requirements.

1.2.2.4 The Closed-Cycle - The major differences between the closed- and open-cycle systems are the heat exchangers and working fluids. In the closed-cycle OTEC system, warm water is pumped through an evaporator containing a working fluid (ammonia or Freon™), and the vaporized working fluid drives a gas turbine which provides the power output. After passage

through the turbine, the vapor is condensed by colder water drawn from the lower ocean, and then pumped back into the evaporator for reuse in the same cycle. No conventional "fuel" of any kind is used: the enclosed working fluid is evaporated and condensed repeatedly by heat transfer across heat exchangers, using warm surface waters and colder deep ocean waters. A schematic diagram of the closed-cycle OTEC power system is depicted in Figure 1-4 (DOE, 1979a).

The closed-cycle requires massive heat exchanger units, which may constitute nearly 50% of the capital cost of a closed-cycle power plant. The heat exchangers are susceptible to decreased efficiencies due to biofouling, especially on the warm water side.

The closed-cycle system operates at pressures of about 125 psia (ammonia working fluid), which necessitates thicker walled heat exchangers than in the open-cycle. There are potential safety hazards associated with the use of ammonia or freon as working fluids. Biofouling control methods may create serious environmental problems. Pressure losses are associated with mechanical cleaning methods for biofouling removal.

a. Heat Exchangers - The closed-cycle OTEC plant will have warm and cold heat exchanger units. The surface areas of these heat exchangers constitute sources of metals which may be released into the marine environment as a result of erosion and corrosion.

(1) Types - The amount of heat transferred in a given period of time is a function of the surface area contact and the thermal conductivity of the material. There are two main types of designs considered for OTEC heat exchangers: tube-in-shell and plate.

Tube-in-shell is the most frequently studied heat exchanger. This configuration consists of a number of parallel tubes, the ends of which are mated to a flat tube sheet. A shell is then wrapped around the bundle of tubes between the tube sheets. Seawater is

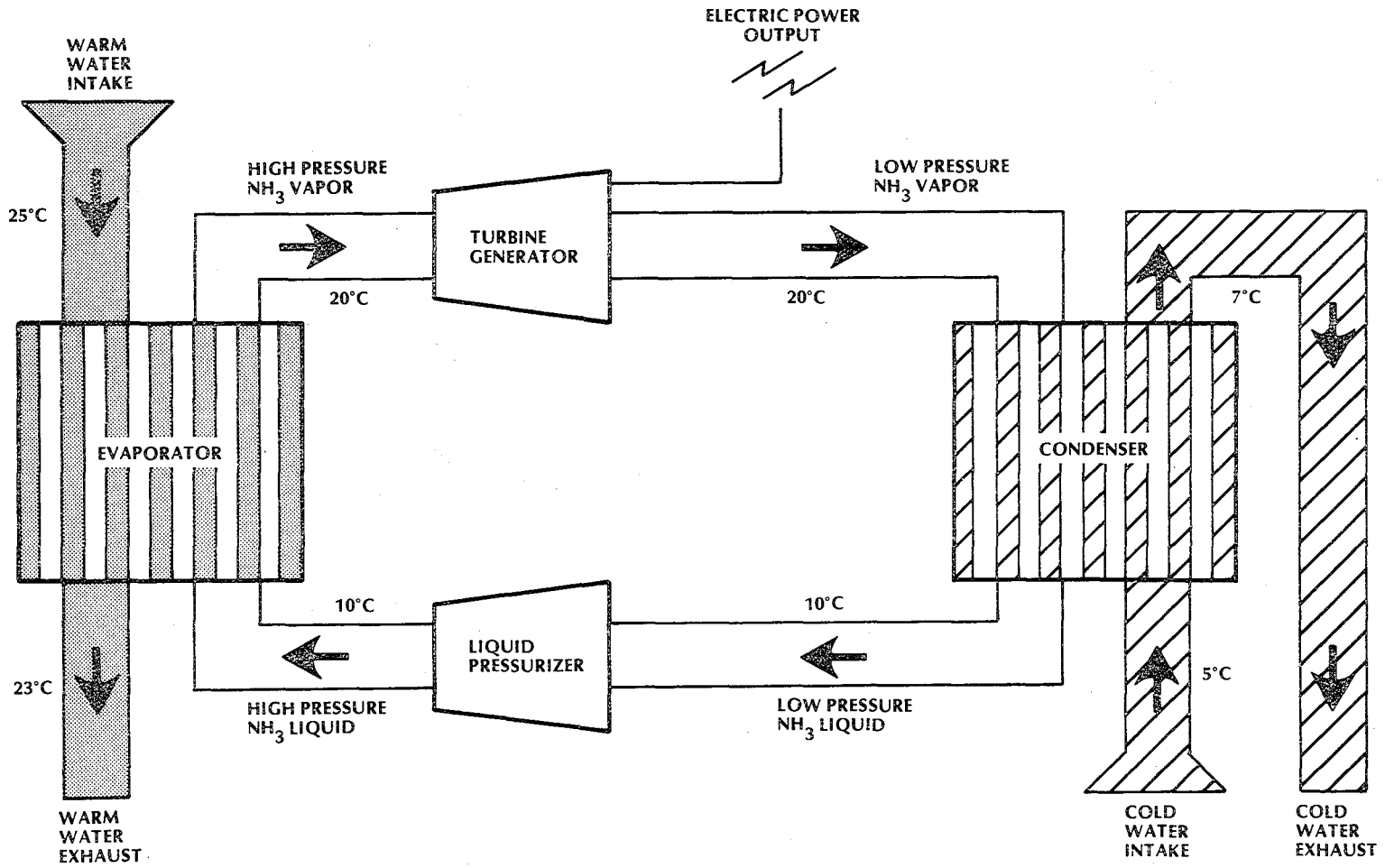

Figure 1-4. Schematic Diagram of Closed-Cycle OTEC Power System
 Source: DOE, 1979a

circulated inside the tubes, and the working fluid is applied to the outside of the tubes. The tube bundles may be oriented either horizontally or vertically. A typical horizontal evaporator bundle is illustrated in Figure 1-5.

The plate type of heat exchanger consists of a series of thin metal plates packed closely together. The plates are sealed together in pairs with spaces left open between each sealed pair. The working fluid circulates within the sealed pairs of plates while seawater circulates between the pairs of sealed plates. One possible plate-type heat exchanger design is illustrated in Figure 1-6.

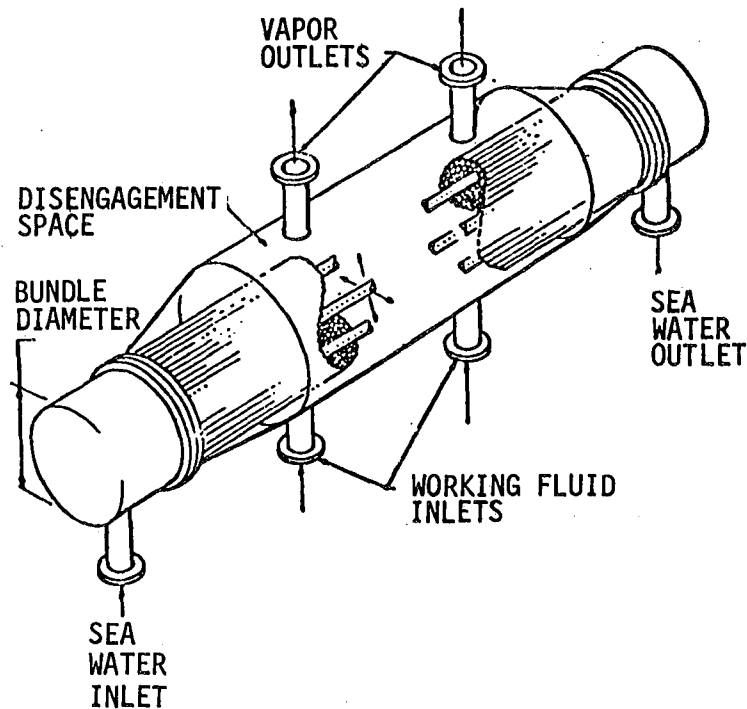

Figure 1-5. Tube-in-Shell Heat Exchanger

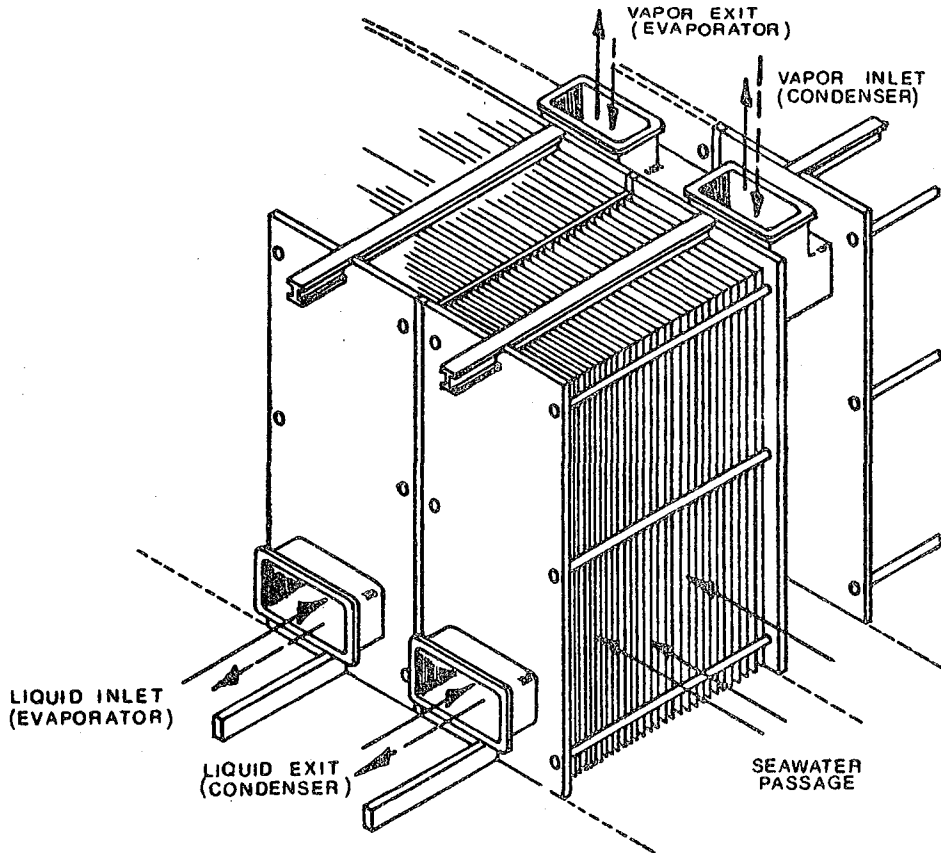

Figure 1-6. One Possible Plate Type Heat Exchanger
 Source: Berndt and Connel, 1978

- (2) Materials - The ideal heat exchanger material must be readily formed and tooled, have a high thermal conductivity, be resistant to corrosion and erosion, and be inexpensive. Various materials have been studied to determine their suitability for use in OTEC heat exchangers. The most likely candidates to emerge are commercially pure titanium, aluminum alloys, steel alloys, and copper alloys. Summaries of studies relating the candidate materials to these performance parameters have been published by Rosales et al. (1978).

- (a) Titanium is a popular choice. It has a relatively high thermal conductivity and has outstanding corrosion-erosion characteristics both in seawater and ammonia environments. The unit weight cost is high but may be cut by using thinner stock. This is possible since extra thickness for corrosion allowance will not be required. The metal is strong and easily formed.
- (b) Aluminum alloys exhibit excellent thermal conductivity, are easy to form, relatively inexpensive, easily obtainable, and have a low density. A possible drawback lies in their corrosion characteristics in seawater and ammonia. Of the alloys, 5052 is best suited for use in a seawater environment. Alloy 6063 is readily extrudable in a fluted configuration, while 5052 is not; however, 6063 is more prone to pitting than 5052.
- (c) Stainless steel alloys have a high nickel and chromium content, and displays excellent corrosion resistance in seawater. It is easily formable, readily available, and has adequate thermal conductivities. The steel alloys are dense; Rosales et al., (1978) reported that, for equal thicknesses, steel tubing may approach the price of titanium. One alloy, Allegheny 6X CRES is frequently described as the steel alloy most likely to be used in OTEC operations. This alloy exhibits good resistance to pitting and corrosion.
- (d) Copper alloys with nickel have a long history of corrosion resistance in seawater applications, and are resistant to biofouling. Copper alloys are easy to form, have high thermal conductivity, and are readily available at reasonable prices. The major disadvantages are its susceptibility to corrosion in ammonia systems and environmental effects resulting from leaching.

- b. Biofouling Control - OTEC plants operate at extremely low efficiencies (3% to 4%), compared to fossil fuel plants (as high as 42%); therefore, losses in the heat transfer coefficient across the heat exchangers are a major problem (Office of Technology Assessment, 1978). The low operation temperatures will necessitate large quantities of heat to be transferred per unit of net power produced.

Because of the large quantity of heat to be transferred and the small temperature differences available, the heat exchangers are very large and represent about half of the capital costs. Field studies underway by DOE are identifying the contributing factors surrounding a decrease in the heat transfer coefficient on the heat exchanger surface. Evidence from coastal power plants indicates that biofouling may play a significant role. However, the effect of corrosion on heat transfer is also under evaluation. Fouling has a strong effect on heat exchanger performance and limits the design options that might be employed to reduce the cost of the heat exchangers.

Fouling is a general term which includes all types and sources of materials that may be deposited or formed on a surface. Although fouling occurs throughout the power and process industries, it is not well understood. Fouling may be classified into two general categories: (1) "micro"--films of slimes in which the organisms are too small to be seen by the naked eye, and (2) "macro"--visible organisms such as worms, barnacles, and mussels. Microfouling is a major concern on the OTEC heat exchanger surface. Bell (1977) stated that a 50-micrometer thick slime layer corresponds to the thermal resistance of fouling (R_f) of approximately $0.88 \times 10^{-4} \text{ hr m}^2 \text{ }^\circ\text{KW}^{-1}$, which is equal to a 15% to 25% decrease in heat transfer efficiency. A fouling deposit heavy enough to be seen by the unaided eye is an unacceptable buildup. The relationship between the R_f value and the fouling thickness is shown in Figure 1-7.

All microfouling cannot be prevented with available technology; a combination of techniques will likely be used to maintain the heat exchanger surface at optimal efficiency. Biofouling control and cleaning

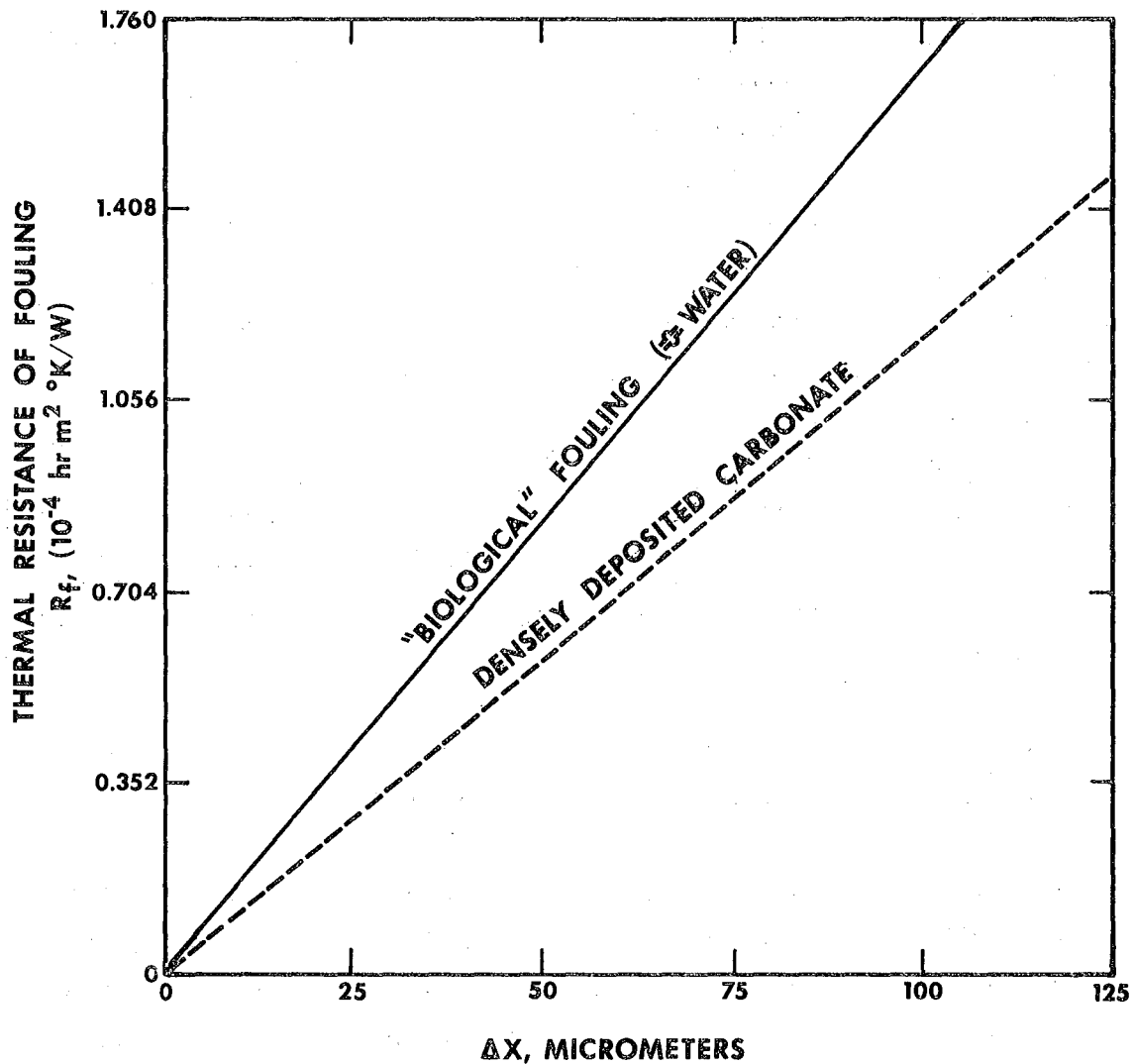

Figure 1-7. Estimated Relationship Between Thickness of Fouling Deposit and the Thermal Resistance, R_f .
Source: Bell, 1977

methods can be divided into three categories: (1) chemical methods, (2) mechanical methods, and (3) other methods. Chemical methods are often used to slow the rate of biofouling (control); they do not remove the material. Mechanical methods are used as necessary to remove the biofouling.

- (1) Chemical Methods - Chemical methods can be used for biofouling control of tube and non-tube heat exchangers. One of the most widely used methods for the control of fouling is chlorination. Besides being an extremely effective method, chlorine is also economical to produce and can be generated electrolytically from seawater. Producing chlorine on an OTEC plant eliminates storage and handling of the hazardous gas.

The dosage rate has not been determined for OTEC plants. The preoperational plant (OTEC-1) estimates range from 0.2 to 1.6 mg liter⁻¹. Chlorine application may be either continuous or pulsed. Continuous releases are generally applied in lower concentrations than pulsed releases. The discharge of chlorinated cooling waters for more than two hours in any one day is restricted (EPA, 1976b). The allowable discharge concentration for these two hours must average 0.2 mg liter⁻¹ for 30 consecutive days, with a maximum of 0.5 mg liter⁻¹.

Other chemical methods for biofouling control include the use of chlorine dioxide, chlorine dioxide plus chlorine, bromine, or bromine chlorine. The annual cost of these methods is between 2 and 10 times greater than the annual cost of chlorine.

Chemical cleaning, in contrast to chemical control, requires draining and isolation of the heat exchanger module, followed by foaming, recirculating, soaking, and purging of acidic or basic cleaning solutions. Cleaning compounds dissolve, decompose, and/or loosen bonds between fouling layers and heat exchanger surfaces. After cleaning, the heat exchanger is drained and rinsed. Incorporation of a chemical cleaning system in an OTEC plant will require several special features and design modifications including (1) addition of heat exchanger modules with appropriate valving which would allow isolation of smaller units to minimize overall shutdown periods, (2) a piping network to connect submodules to storage and treatment facilities, (3) proper venting capabilities and (4) large acid/base storage and treatment tanks.

- (2) Mechanical Methods - Mechanical biofouling control methods are limited to tube heat exchangers (Hagel et al. 1977). After fouling has built to the maximum allowable level, mechanical cleaning devices may be used to remove the material. Mechanical cleaning methods suggested for OTEC platforms are Amertap balls and M.A.N. flow-driven brushes.

The Amertap system may be used continuously and cleans the tubes using slightly oversize foam rubber balls which are injected into the water in front of the tube sheets. The balls are compressed as they traverse the condenser tube, and the rubbing and abrasive action cleans the tube. At the end of the heat exchangers, a screening mechanism removes the balls from the water flow; the balls are then recirculated back through the heat exchangers. The continuously circulating balls remove the primary slime layer soon after formation and eliminate later fouling stages.

The ball size, composition, density, and surface texture (abrasive banding) may be adjusted to solve many tube fouling conditions. The balls may be soaked in a biocide to increase their effectiveness; however, additional research is necessary to investigate this possibility.

The large OTEC heat exchangers may not allow simple injection of the balls into the water system. A radially indexed rotating arm emitter and collector device has been developed for the Amertap System to provide complete coverage of the heat exchanger tube sheet.

The Machinefactory Augsburg-Nuremberg (M.A.N.) brush system is an automated mechanical tube scrubber. M.A.N. brushes are cylindrical, tufted brushes held in a plastic cage which guides them through the tube. The protruding tufts scrub the deposits off the walls as they are pumped back and forth through the tubes by reversing the flow direction of the seawater. Braswell et al. (1979) reported that the fouling resistance of heat exchanger tubes was maintained well below the maximum acceptable limit for OTEC operation, although macro-

fouling on the brush itself and entrained debris may clog the brush retaining cages and put the tube out of service. Although sensitive to the blockage, the M.A.N. system is adaptable to the cleaning of enhanced surface texture tubes. Additional piping and valves are required to reverse the flow within the tubes.

- (3) Other Methods - Other methods considered for biofouling control include ultrasonics, abrasive cleaning, and thermal shock. Ultrasonics have been used with some success to prevent barnacle fouling on ship hulls. However, Burton and Liden (1977) report that heavy microfouling cannot be inhibited on ship hulls by a broad range of frequencies and durations. Pandolfini et al. (1979) developed a crude initial version of an ultrasonic cleaner which inhibited microfouling on heat exchanger tubes, similar to those which will be used in the closed-cycle system. Additional research is required to demonstrate the feasibility of ultrasonic cleaning.

Abrasive cleaning is performed by adding an abrasive mixture (e.g., sand, diatomaceous earth, or detergents) to the water flowing through the heat exchangers. The abrasive mixture dislodges the material that has attached to the heat exchangers. The dislodged material may also act as an abrasive as it passes out of the heat exchangers. This method efficiently removes fouling deposits and withdraws the material from the system, but the slurry also causes the destruction of protective films and the erosional loss of the heat exchanger surface material.

At present the only slurry medium compatible with OTEC design is diatomaceous earth. However, the entire yearly production in the United States of diatomaceous earth would be needed to make a 1% slurry for a 24-hour cleaning cycle of a 100-MW OTEC plant. Thus, unless an inexpensive recovery and recirculation procedure is developed, or a material such as sand is found to be acceptable, near-term applicability of slurry cleaning is not feasible.

Thermal shock is commonly used to control macrofouling at coastal generating stations (Graham et al., 1975, 1977; Stock and Strachan, 1977). A portion of the heated effluent is recirculated through the condensing unit until the water temperature is elevated to 39°C. OTEC plants cannot achieve these high temperatures without large parasitic power losses.

In contrast, stopping the pumps in one system, allowing the working fluid to circulate, will "shock" the other operating system.

The effect of an immediate temperature change of 20°C on subtropical-tropical fouling organisms is not known, although such changes may be fatal (Araga and Tanase, 1968). Thermal shock will require a complete stoppage of the closed-cycle system. For example, faunal death due to cold temperatures is particularly prevalent in warm temperate and subtropical areas in which cold periods occur irregularly (Kinne, 1970). Mass mortality in low-latitude waters can occur during severe winters, when the temperature drops below the organism's minimum temperature tolerance for several days. Catastrophic mortality has been noted in the Gulf of Mexico during winter storms from the north, where deep waters are upwelled sharply, reducing the surface water temperatures. The extent of mortality may depend more on the rapidity of the temperature drop rather than the minimum temperature reached (Storey, 1937).

- c. Working Fluids - The ideal working fluid will have a low boiling point and be compatible with heat exchanger material (DOE, 1979a). Ammonia and Freon™ are candidates for the closed-cycle working fluid. Propane and isobutane have also been considered.

Owens (1978) compared ammonia, Freon™, propane, and isobutane fluids, based on the area of heat exchanger required to produce 25-MW net power output of an optimal plant design. Ammonia requires the least amount of

surface area per kilowatt of net power. As the level of tube enhancement increases, the amount of heat exchanger area required by the working fluids decreases significantly. Although the difference in area requirements between ammonia and the other fluids decreases as the tubes are further enhanced, ammonia still requires a smaller area and thus will result in decreased heat exchanger costs (Owens, 1978).

1.2.2.5 The Open-Cycle - The greater probability of achieving OTEC performance goals with a closed-cycle system led to its selection as the baseline power system for initial demonstration. Although the current OTEC Program emphasizes the closed-cycle system, the open-cycle system is being evaluated for second generation application, as warranted by technological developments and analyses (DOE, 1979a).

The open-cycle OTEC system operates in much the same way as the closed-cycle system, except that seawater is used as the working fluid, obviating the need for heat exchanger surfaces. Warm surface seawater flows into a partially evacuated evaporator where the lowered pressure causes it to boil. The steam, after passing through a turbine, is condensed by cooler ocean water. Freshwater can be produced as a byproduct of the open-cycle system if the steam is condensed using heat exchangers instead of direct contact spray of cold seawater. Again, no conventional fuel is used (DOE, 1979a). The schematic diagram of the open cycle OTEC power system appears as Figure 1-8 (Watt et al., 1978).

The disadvantage most often cited for the open cycle is that it would require a turbine of prohibitive size (Office of Technology Assessment, 1978). In essence, the enthalpy change associated with a seawater working fluid is low, requiring a much larger turbine diameter. A single turbine for a 100-MW plant could be as much as 57 m in diameter (Office of Technology Assessment, 1978). The large-diameter turbine will have extremely high tip velocities; so great, that new high-strength materials must be developed. Deaeration pumps must be added to an open-cycle system to remove the uncondensable gases which will evolve during the flash evaporation phase, because gases in the boiler reduce turbine output. The open-cycle system incorporates heat exchangers to condense exhaust vapors, and will be capable of producing fresh water as a byproduct.

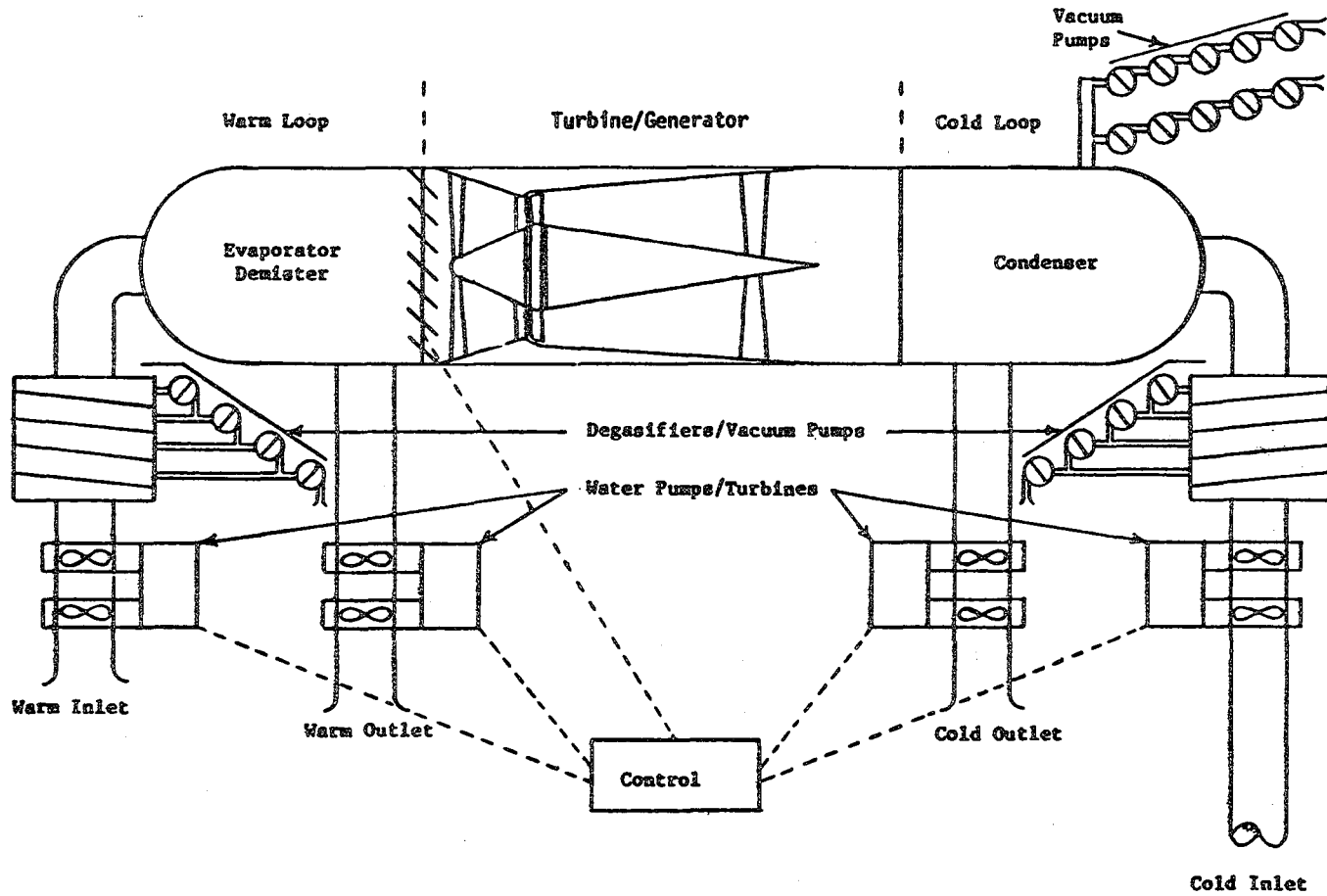

Figure 1-8. General System Layout of an Open-Cycle OTEC Plant
Source: Watt et al., 1977

- a. Evacuation Chamber - The open-cycle system necessitates the prevention of noncondensable gas accumulation in the condenser. Because of this requirement, the gas removal prior to flashing is mandatory. This can be accomplished by pumping the noncondensable gases from the condenser up to atmospheric pressure. However, massive compressor power is required. The gases are most effectively and efficiently removed under moderately low pressure chambers and by counterflow staged compressors (Watt et al., 1977).

- b. Turbine - In recent years, several turbine designs have been examined for OTEC application. A series of small turbine generators are considered to be not cost-effective because of the interface problems. Turbine blades are expected to optimize at between 15 and 30 m in size, which exceeds present steam turbine hardware by a factor of 11 to 23. These turbine blades, likely composed of steel, present potential surfaces for corrosion and erosion of trace elements (Watt et al., 1977). There is an inverse relationship between turbine size and rotational speeds; thus the costing rate of the generator increases.

1.3 OTEC PLATFORM SITING CONSIDERATIONS

Site selection is a critical factor in OTEC demonstration, deployment, and commercialization. Platform siting is based upon the type of platform and the environment. Suitable characteristics for siting include:

- Minimal Siting Criteria;
- Economic Feasibility;
- Social Issues;
- Potential Environmental Consequences.

Only with careful weighing of these criteria can the optimal sites be identified for each type of OTEC platform.

1.3.1 Minimum Siting Criteria

Desirable characteristics for siting OTEC plants are:

- Thermal resource availability of at least 20°C annual average; and
- Oceanographic currents not exceeding operational limits (moored and plant-ship only).

For cost-effective operation, the thermal resource requirements have been defined as a delta t of 20°C annual average between the surface and deep ocean waters. Candidate areas of the world have been determined and are illustrated in Chapter 2, Figure 2-1.

Platform operation in the presence of strong oceanographic surface or subsurface currents may not be feasible because of the stresses imposed on the cold water pipe and the mechanisms for holding position or maneuvering may exceed the operational power available.

To the extent possible, low annual frequencies of extreme meteorological weather frequencies and associated sea-states as a result of typhoons or hurricanes are a desired trait of an OTEC site. Also, ecologically sensitive areas and marine sanctuaries must be avoided.

1.3.2 Economic Feasibility

Paramount after identifying the candidate locations for OTEC siting are the economics surrounding plant deployment, operation, and maintenance:

- Present and projected power requirements;
- Potential for industrial growth;
- Market potential for the products; and
- Resource availability to satisfy power requirements.

Present and projected power requirements must be identified for each region. Additionally, the power requirements of potential industries which may develop in each locale should be determined for adequate estimation of power requirements. For OTEC plantships, platform siting should be near the market potential of ammonia or aluminum. Other considerations include the availability of raw materials, the cost to produce the product, the market demand of the product, and the distance to the market.

1.3.3 Social Issues

When minimal siting and economic feasibility criteria are established, the social concerns have major roles in determining siting feasibility. The social issues include:

- Proximity to the United States and its trust territories;
- Aesthetics (visual nuisance); and
- Cultural conflicts.

In this EA, the area within the ERZ surrounding the United States and its territories and possessions are considered for OTEC deployments. Plant-ships producing ammonia or aluminum are considered to graze the world's oceans beyond the 200-mile ERZ of other countries.

The presence of sacred or culturally significant areas may preclude OTEC siting.

1.3.4 Potential Environmental Consequences

The environments for OTEC development, demonstration, and commercialization occur in the tropical-subtropical oceanic environment. Complete characterization of the site specific features of OTEC candidate sites must be carefully reviewed to determine if any significant environmental consequences will result from platform operation. Potential design modifications to reduce or mitigate potential impacts are fundamental components of the environmental analysis. In Chapter 2, the environmental description of a typical OTEC site is presented. Chapter 3 provides an evaluation of the potential environmental impacts that may result from platform operation.

Chapter 2

THE EXISTING ENVIRONMENT

This chapter describes a generic oceanic environment typical of the OTEC thermal resource regions. It is not intended to be a site specific description. The parameters considered are those which: (1) describe the salient environmental and economic features under which a platform or cluster of platforms is projected to operate, and (2) facilitate the assessment of impacts. Typical values or characteristics of the parameters are presented. Frequently several sources of data were pooled to prepare this oceanic characterization. Site or regional characterizations for OTEC resource areas in Hawaii, Puerto Rico, Guam, Eastern Gulf of Mexico, South Atlantic and the Pacific are included in Appendix B.

2.1 GEOLOGY

2.1.1 Data Requirements

Geological data defining stratigraphy, soil mechanics and bathymetry are important to the siting of moored OTEC platforms. Stratigraphy will describe the substrate composition to determine the ease of submarine cable installation and suitability for anchoring. Soil mechanics data assesses the anchor holding capacity of the substrate. Bathymetric data are required to examine bottom slope, irregularity, and roughness of the cable route.

2.1.2 Description

In potential OTEC island areas, elevations rise quickly from great ocean depths. It is the close juxtaposition of land to the deep ocean which makes island areas particularly attractive for OTEC development. Ocean depths over 1,000 m occur within 3 km of most potential OTEC island sites. Terraces, however, do occur on most of these slopes.

Sediment composition can range from terrigenous to biogenic character; the thickness of individual layers are variable, ranging from thin veneer layers overlaying hard substrates to soft, penetrable substrates.

2.2 PHYSICAL OCEANOGRAPHY

2.2.1 Data Requirements

Several physical oceanographic parameters are important for OTEC operations. The thermal profile is fundamentally critical to OTEC operation; OTEC siting areas must have an annual minimum temperature difference of 20°C between surface and deep ocean waters. The mixed layer depth provides information on the structure of the upper water column. Mixed layer depths must be deep enough to ensure that the warm water resource is available at the intake depth. The mixed layer depth is also a consideration for selecting the discharge depth: the discharge of waters below the mixed layer minimizes the possibility of recirculation.

The circulation patterns at OTEC sites are important from two points of view: (1) resource renewal, and (2) plume dynamics. Circulation patterns replenish the waters to an OTEC site, thus maintaining the thermal resource. Currents are important to disperse the discharged warm and cold ocean waters used by the OTEC platform. Countercurrents will apply stress to the cold water pipe; winds and waves supply forces which act on the platform. The photic zone is important in order to define the extent of biological utilization that may be influenced by the redistribution of nutrients.

Characteristics of the above parameters are discussed in the following paragraphs and summarized in Table 2-1.

2.2.2 Description

2.2.2.1 Thermal Resource - The world's thermal resource for OTEC is illustrated in Figure 2-1. The contours are illustrated for annual average temperature differences between surface and 1,000-m depth waters.

TABLE 2-1
 PHYSICAL OCEANOGRAPHIC FEATURES OF POTENTIAL OTEC AREAS

Parameter	Range	Mean	Reference
Annual Mean Delta t (°C)	20.1 to 24.3	21.9	ODSI (1979a-j; 1977 a-f)
Annual Average Mixed Layer Depth (m)	22 to 89	56	ODSI (1979 a-h,j; 1977 a-f)
Surface Current Speeds; Monthly ₁ Average (cm sec ⁻¹)	11 to 37 and 77+	N/A	ODSI (1979 a-j); Defant (1961)
Photic Zone Depth (m) (1% Light Level)	120 to 140	125	Hargraves et al. (1970) Gundersen et al. (1976) Walters (1976)

N/A = Not available

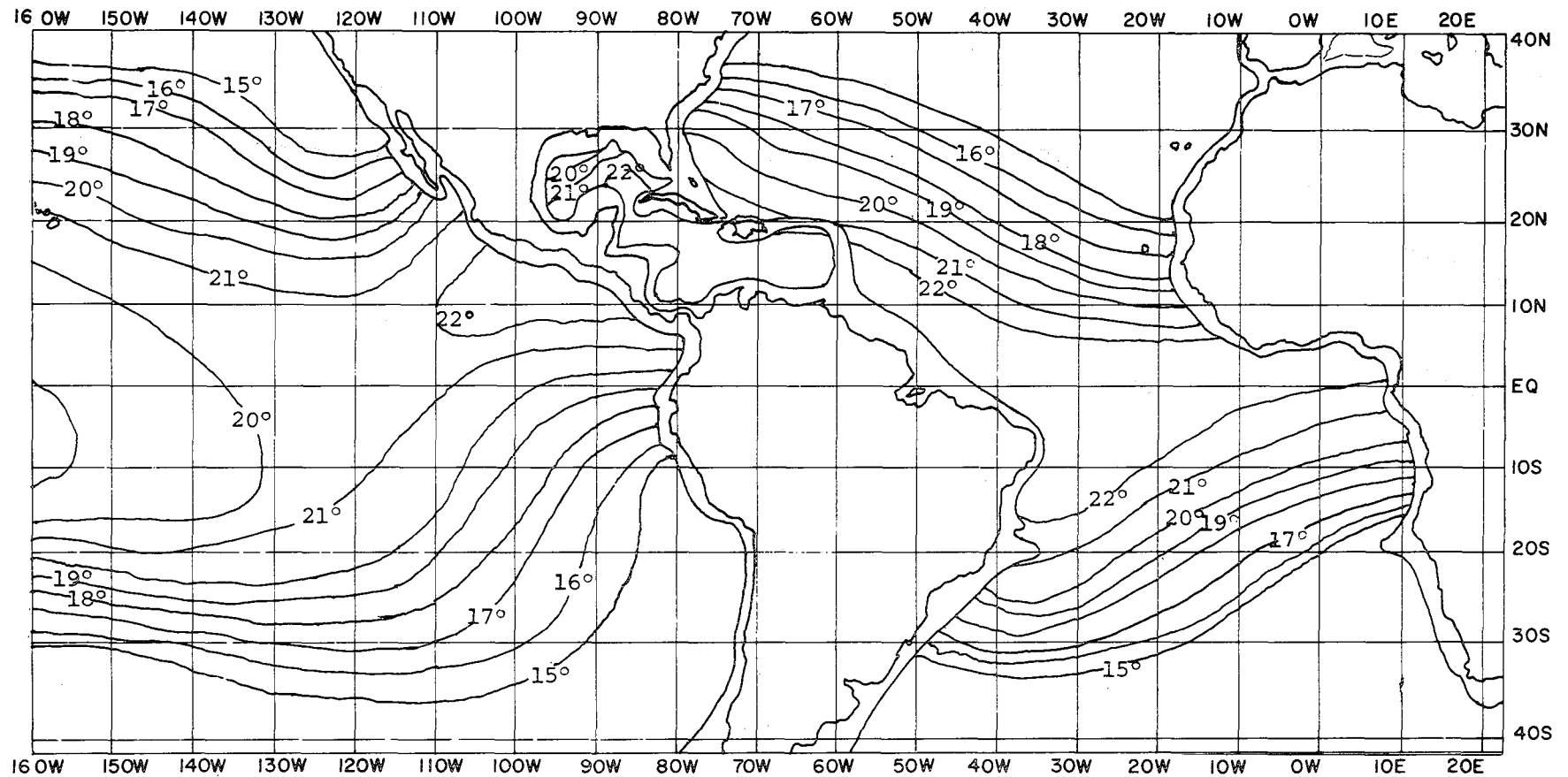

Figure 2-1. The OTEC Thermal Resource Area.
Contours indicate temperature differential (°C) between
surface and 1,000m depth.
Source: DOE, 1978a

2-5

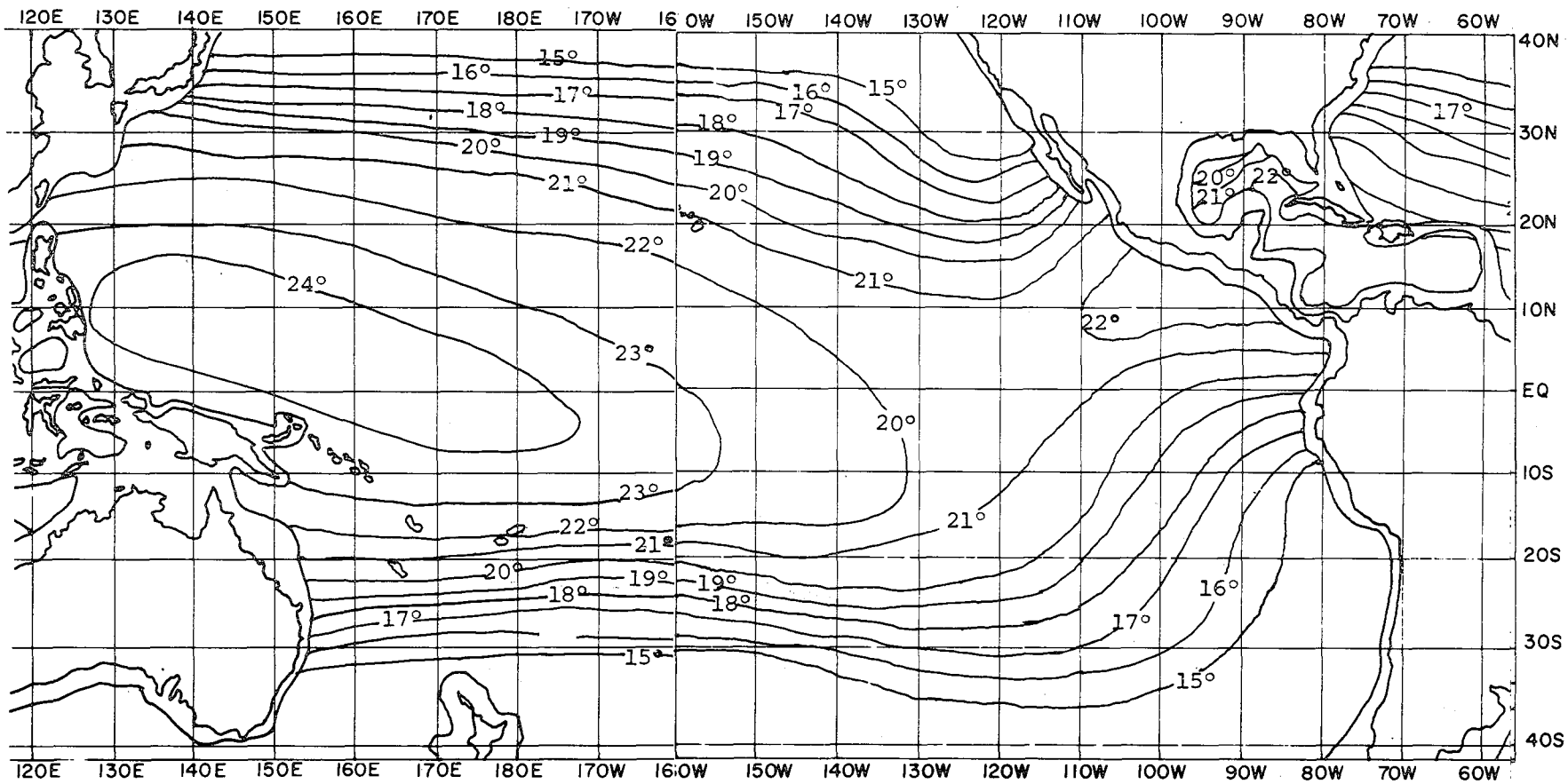

Figure 2-1. (Continued)

The mixed layer depth is defined as the level at which the temperature drops 1°C below the surface water value and indicates the top of the thermocline (ODSI, 1977a). The mixed layer seasonally migrates vertically with the maximum depth observed with the onset of winter. The yearly averages for the mixed layer depth in the thermal resource regions range from 22 to 89 m with an overall average of about 56 m (ODSI, 1977a-f; ODSI, 1979a-j).

2.2.2.2 Circulation - The warm surface waters, the lower extent indicated by the depth of the thermocline, are the limiting resource for OTEC operation. While these waters may be warmed by local insolation, the bulk of the heat stored is obtained from equatorial regions and transported to the platform location by advection.

Currents which replenish these waters are part of a larger circulation pattern, illustrated in Figure 2-2. Also, current speed and direction are site- or regional-specific phenomena influenced by local features. Site studies are presently underway at OTEC candidate sites in the Gulf of Mexico, Puerto Rico, Hawaii, and the South Atlantic to develop a historical record of events for these areas. In general, current speeds range from 10 to in excess of 100 cm sec⁻¹ (Table 2-1).

2.2.2.3 Meteorology - Meteorology records for the OTEC regions indicate that the Gulf of Mexico has the highest frequency of tropical storms and hurricanes while Hawaii has the lowest (Tetra Tech, 1977; Haraguchi, 1975; U.S. Naval Weather Service Command, 1974).

2.2.2.4 Photic Zone Depth - The photic zone depth is the point at which light is attenuated to 1% of its surface value (Parsons and Takahashi, 1973). This depth is important because of the strong influence light has on primary productivity. Available data for the oceanic environment indicate that the photic zone depth ranges between 120 and 140 m, with an average of 125 m (Table 2-1). This depth of light penetration is characteristic of very clear, blue oceanic waters.

LARGE SCALE DISTRIBUTION OF OTEC THERMAL RESOURCE

$\Delta T(^{\circ}\text{C})$ BETWEEN SURFACE AND 1000 METER DEPTHS

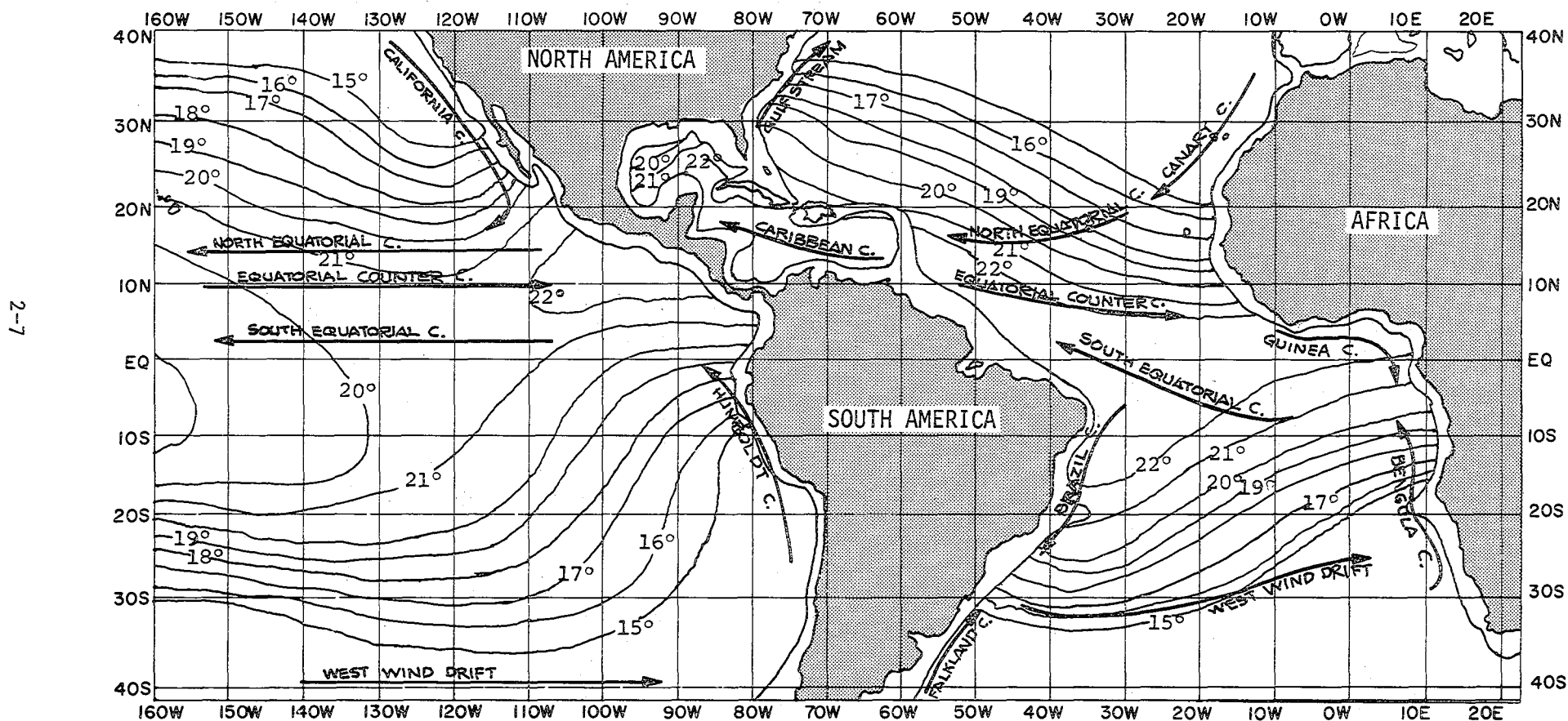

Figure 2-2. Large-Scale Circulation Patterns

LARGE SCALE DISTRIBUTION OF OTEC THERMAL RESOURCE

$\Delta T(^{\circ}\text{C})$ BETWEEN SURFACE AND 1000 METER DEPTH

2-8

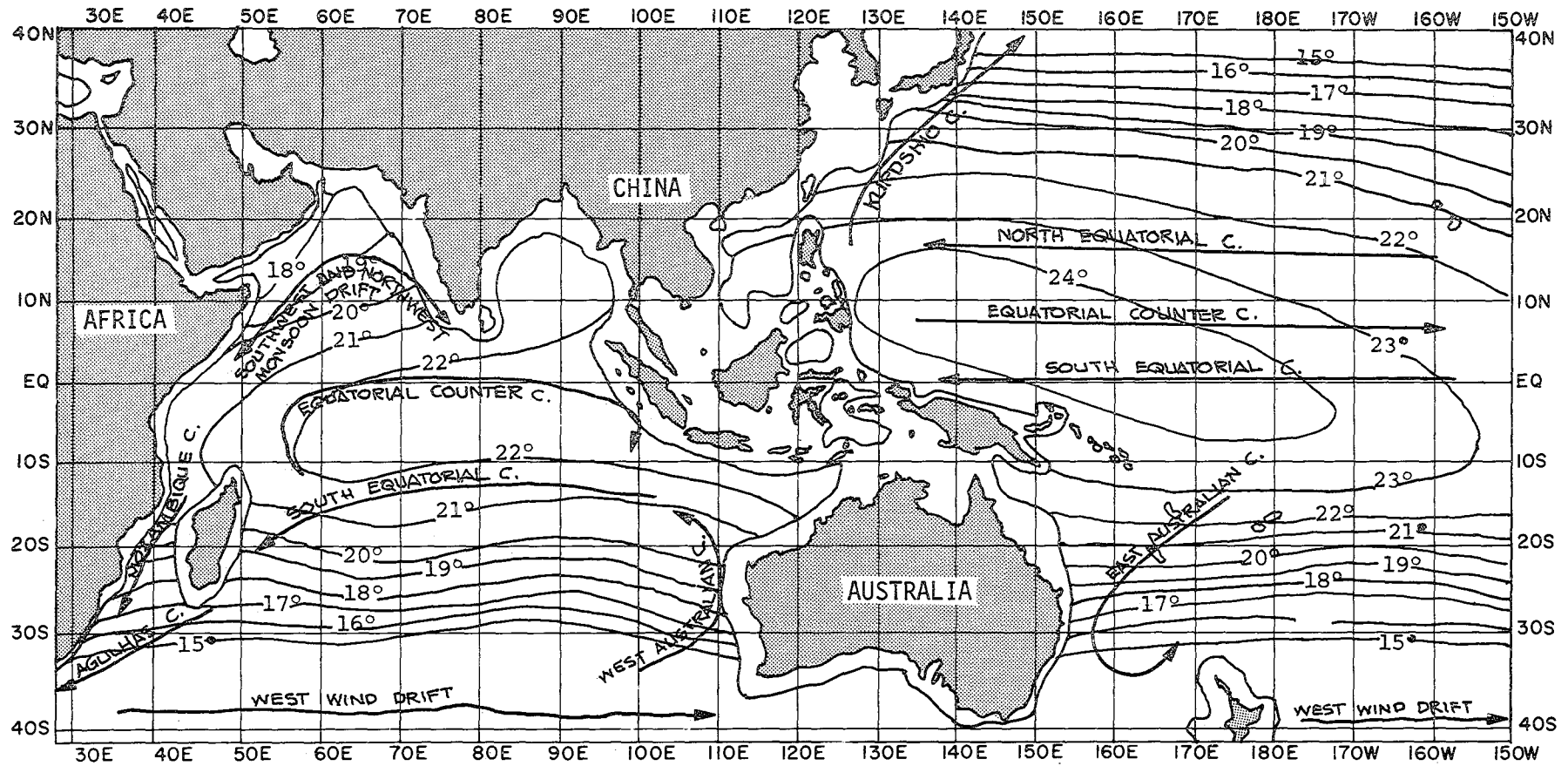

Figure 2-2. (Continued)

2.3 CHEMICAL OCEANOGRAPHY

2.3.1 Data Requirements

Chemical characteristics important for OTEC environmental analysis include nutrient and dissolved oxygen profiles encompassing the depth of the intakes, depth of discharge and plume stabilization depth. These values are necessary for assessment of the effect of water mass redistribution. Other important factors are ambient levels of trace constituents and organohalogen compounds in the water column and in tissues of resident organisms.

2.3.2 Description

2.3.2.1 Nutrients - Nitrate concentrations are very low in surface waters, increase with depth through the water column, and reach a maxima at 700 to 800 m depths, which slightly exceed the values reported at 1,000 m depth of 15 to 35 ug-at liter⁻¹ (Quinby-Hunt, 1979; DOE, 1979c). Ortho-phosphate and silicates display similar trends with low values at the surface, and reaching a maxima at 700 to 800 m depth.

2.3.2.2 Dissolved Oxygen - Open-cycle OTEC plants will discharge degassed ocean water which may reduce ambient dissolved oxygen concentrations in receiving waters to values lower than the minimum required to support resident organisms. Also, the release of biomass destroyed by plant operation will require dissolved oxygen for oxidation.

Dissolved oxygen concentrations are typically 5.0 ml liter⁻¹ in surface water, decrease to a minimum of 1.0 ml liter⁻¹ at 500 m depth, and increase to 3.0 ml liter⁻¹ at 1,000 m depth (DOE, 1979c). Values are listed in Table 2-2.

2.3.2.3 Trace Constituents and Organohalogen Compounds - Concentrations of constituents likely to be released from OTEC facilities are near the detection limits of analytical instrumentation.

TABLE 2-2
CHEMICAL CHARACTERIZATION OF POTENTIAL OTEC AREAS

	Depth	Pacific	Hawaii	Gulf of Mexico	Puerto Rico	South Atlantic	General Ocean
Nitrate mg-atom m ⁻³	0-50 m	0.2 ^a 0.04 ^b	0.05 ^c 0.3 ^d	0.5 - 1.0 ^e	0.7 ^f	0.1 ^g	0.3
	125 m	0.5 ^e 0.2 ^d	0.6 ^c	7 ^e	0.7 ^f	8.0 ^g	3
	900 m	34 ^g	45 ^h 35 ^d	30 ^e	23 ^f	29.0 ^g	30
	0-50 m	0.26 ^{b,i}	0.2 ^{c,d}	0.2 ^j	0.4 ^k	0.1 ^g	0.25
Phosphate mg-atom m ³	125 m	0.6 ^g	0.2 ^{c,d}	0.5 ^j	0.5 ^k	0.3 ^g	0.3
	900 m	1.4 ^a	3 ^d	1.9 ^j	2.0 ^k	2.0 ^g	2.0
	Surface	2.4 ^b	4.8 ^d	0.5 ^e	1 ^e	0 ^g	1.75
Silicate mg-atom m ⁻³	125 m	25 ^g	3.7 ^d	2 ^e	1 ^e	5 ^g	3.0
	900 m	150 ^g	86 ^d	25 ^e	25 ^e	20 ^g	25
	0-50 m	4.3 ^a 4.5 ^b 3 ^b	5.0 ^c 7.5 ^d 4.4 ^c	4.8 ^l 3.6 ^e	4.2 ^k 3.6 ^k	4.8 ^m 3.0 ^m	5.0 4.0
Dissolved oxygen ml liter ⁻¹	125 m	4.5 ^b 3 ^b	7.5 ^d 4.4 ^c	3.6 ^e	3.6 ^k	3.0 ^m	4.0
	900 m	No Data	1.0 ⁿ 1.7 ^d	3.9 ^e	3.3 ^k	3.4 ^m	3.0
	Oxygen Minimum Layer (ml/liter)	No Data	600 m (1.5) ^d	500 m (3.4) ^e	600 m (2.6) ^k	200 m (1.8) ^m	- -

Sources: (a) Arsen'ev et al., 1971 (h) Gundersen et al., 1972
 (b) Love, 1971 (i) Schulenberger, 1978
 (c) Gundersen and Palmer, 1972 (j) Churgin and Halminski, 1974
 (d) Wilde, 1979 (k) Halminski, 1975
 (e) Cummings et al., 1977 (l) Michel and Foyo, 1976
 (f) Atwood et al., 1976 (m) Gross, 1972
 (g) Sverdrup et al., 1942 (n) Gordon, 1970

2.4 BIOLOGICAL OCEANOGRAPHY

2.4.1 Data Requirements

OTEC platforms will affect the marine environment from the neuston layer at the air-sea interface to the boundary layer between the mesopelagic and bathypelagic zones at depths exceeding 1,000 m. Effects are expected to be less significant on the mesopelagic zone than the epipelagic or bathypelagic zones, however data from all depths are required because organisms migrate between layers.

A biological profile of a region must include all aspects of an ecosystem, from the nutrient-light regimes, through the lower trophic levels of microbiota, up to and including the top nektonic carnivores (squid, fish, sea turtles, marine mammals) and sea birds. Also important are the species composition and turnover rates of the lower trophic levels. Ichthyoplankton recruitment in the area in relation to the local catch must be determined, along with the distribution, abundance, and population dynamics of fish, whales, and other marine mammals. Special attention must be given to the transient occurrence of endangered and threatened species and the species of commercial or economic importance, such as tuna, billfish, dolphin, and clupeid fish. Descriptions of the vertical and geographical distribution of the phytoplankton, zooplankton, micronekton, and nekton are necessary in order to assess the potential environmental impacts on biota.

2.4.2 Data Description

2.4.2.1 Phytoplankton - Phytoplankton are free-floating algae which produce organic matter upon which the rest of the marine food chain is built. Phytoplankton range from small, single-celled plants, to large multi-cellular brown algae, Sargassum. Sargassum is a large unattached brown alga which may occur infrequently in some of the OTEC resource areas. The measurement of chlorophyll a, a photosynthetic pigment, provides an estimate of phytoplankton biomass. The average chlorophyll a concentrations reported in tropical-subtropical waters are listed in Table 2-3. Generally, surface chlorophyll a

values in oceanic waters are low (0.05 to 0.10 mg chl a m⁻³), but increase with depth to a subsurface maximum. The subsurface maximum is on the order of 0.1 to 0.3 mg m⁻³ (two to five times greater than at the sea surface), and its depth of occurrence between 75 and 150 m varies spatially and seasonally (Scripps Institution of Oceanography, 1969; Venrick et al., 1973; Eppley et al., 1973; Gundersen et al., 1976; Schulenberger, 1978). Nannoplankton (cells less than 10 micrometers in size) contribute 80% to 90% of the phytoplankton biomass and primary production in tropical oceanic regions (Malone, 1971); however, few studies have investigated this component of the phytoplankton.

The major features of primary production within the OTEC resource regions are listed in Table 2-3. In general, tropical-subtropical oceanic waters have primary production values ranging from 100 to 150 mg C m⁻² day⁻¹; however, much higher production occurs occasionally in the equatorial divergence zone, semi-enclosed seas, shallow seas, upwelling areas, or near land. Areas of low production (less than 100 mg C m⁻² day⁻¹) are confined to the highly oligotrophic gyres in the central Pacific and Atlantic Oceans.

2.4.2.2 Zooplankton - Zooplankton are passively floating and weakly swimming animals of the water column, which are generally considered to be the second trophic level of the marine food chain. Zooplankton are divided into two groups: microzooplankton and macrozooplankton. Microzooplankton are the organisms retained in the 35- to 202-micrometer mesh fraction of filtration netting, such as naupliar and copepodid stages of copepods, ciliate and sarcodine protozoans, and larvaceans. Macrozooplankton are retained in the 80- to 500-micrometer mesh size and are dominated by copepods and chaetognaths, although the eggs and larvae of many types of invertebrates and fish are also included. Available data for microzooplankton and macrozooplankton in tropical-subtropical waters are summarized in Table 2-3, and described in detail in Appendix B.

Microzooplankton are concentrated in the upper 200 m, with an average biomass of 0.8 mg C m⁻³ (Gundersen et al., 1976). However, stocks vary from 0.2 mg C m⁻³ at the surface to a maximum of 3.3 mg C m⁻³ between 60 and 200 m depth (Beers and Stewart, 1971; Gundersen et al., 1976; Hirota, 1977). Standing stocks below 200 m depth are about 10% of those at shallower depths

TABLE 2-3
BIOLOGICAL CHARACTERIZATION OF POTENTIAL OTEC AREAS

Parameter	Depth	Pacific	Hawaii	Gulf of Mexico	Puerto Rico	South Atlantic	General Ocean
Primary Productivity mg C m ⁻² day ⁻¹	0-130 m	50-250 ^a 82 ^c	53-84 ^b	60-100 ^d	30-280 ^e	50-375 ^f	100
Chlorophyll <u>a</u> mg/m ³	0-50 m	0.03-0.10 ^{g,h,i,j}	0.03-0.12 ^{b,c,k,l}	10 mg/m ^{2d}	0.06-0.25 ^{k,m}	No Data	0.1
	80-130 m	0.1-0.3 ^{g,h,i,j}	0.12-0.39 ^{b,c,k,l}		0.15-0.36 ^{k,m}	No Data	0.1
Microzoo- plankton mg C/m ³	0-10 m	No Data	0.2 ^c	No Data	No Data	No Data	0.2
	0-200 m	1.0 ⁿ	0.8 ^c	No Data	No Data	No Data	1.0
	200-350 m	0.1 ^o	No Data	No Data	No Data	No Data	0.1
	350-1,000 m	0.01 ^p	No Data	No Data	No Data	No Data	0.01
Macrozoo- plankton Night:Day Biomass Ratio	0-150 m	1.1 ^q	1.25-1.65 ^s	2.3 ^t	No Data	No Data	1.5
		1.8 ^r					
		1.5 ⁿ					
Macrozoo- plankton Biomass mg C/m ³	0-150 m	0.1-2.0 ^r 3 ^{n,o}	0.5-0.8 ^{s,u,v,w}	0.1-3.0 ^t 1.75-6.0 ^x	No Data	No Data	1.75
		0.7 ^q					
	150-350 m	0.2-0.3 ^{q,r} 0.15-0.7 ^y 0.1-0.25 ^r	0.2 ^u	No Data	No Data	No Data	0.4
	350-1,000 m	0.4 ⁿ	No Data	0.25 ^x	No Data	No Data	0.25

Sources: (a) Koblentz-Mishke et al., 1970 (m) Hargraves et al., 1970
 (b) Gilmartin and Revelante, 1974 (n) Hirota, 1977
 (c) Gundersen et al., 1976 (o) Beers and Stewart, 1969
 (d) Jones et al., 1973 (p) Beers, 1978
 (e) Beers et al., 1968 (q) Vinogradov and Rudyakov, 1971
 (f) Mahnken, 1969 (r) Youngbluth, 1975
 (g) Scripps Institution of Oceanography, 1969 (s) Nakamura, 1955
 (h) Venrick et al., 1973 (t) Howey, 1976
 (i) Eppley et al., 1973 (u) King and Hida, 1954
 (j) Schulenberger, 1978 (v) King and Hida, 1957
 (k) Johnson and Horne, 1979 (w) Shomura and Nakamura, 1969
 (l) Bathen, 1977 (x) Bogdanov et al., 1969
 (y) Vinogradov, 1961

(Beers and Stewart, 1969) and at 900 m probably decrease to 1% of those at the surface depth (Beers, 1978).

A substantial body of data exists from oceanic habitats for macrozooplankton concentrations (biomass), spatial and temporal distributions, taxonomic composition, and biogeography (Bary, 1970; Blackburn, 1976; Blackburn et al., 1970; Brinton, 1962; Bogorov et al., 1968; King and Hida, 1954, 1957; Hirota, 1977; McGowan, 1971, 1974; Michel and Foyo, 1976; Reid, 1962; Vinogradov, 1970). In tropical, blue water regions away from coastal systems, land masses, and seasonal upwelling, estimates of oceanic macrozooplankton biomass in the upper 150 m range from about 0.1 to 6 mg C m⁻³ and average about 1.75 mg C m⁻³. Macrozooplankton biomass values at 1,000 m depth are between 10% and 30% of the surface values (Vinogradov, 1961; Vinogradov, 1970; Vinogradov and Rudyakov, 1971; Youngbluth, 1975).

2.4.2.3 Micronekton - Micronekton are an assemblage of actively swimming organisms which range from 1 to 10 cm in diameter and are usually sampled with midwater trawls. In general, the dominant micronekton groups are: (1) fish: myctophids, gonostomatids, sternoptychids, (2) crustaceans: penaeid and caridean shrimps, euphausiids, mysids, (3) cephalopods, and (4) gelatinous organisms: siphonophores, scyphomedusae, salps, pteropods. The average biomass values of these major micronekton groups, in various regions and depth intervals of the tropical and subtropical Pacific, are summarized in Table 2-4. Biomass varies between areas, but data from Maynard et al. (1975) appear to represent the average micronekton biomass in oceanic areas away from land masses, divergence zones, and upwelling areas.

2.4.2.4 Nekton - The major taxa of tunas and oceanic epipelagic fish of commercial and sport value include the following species (Blackburn 1976; Uchida, 1978): (1) tunas and tuna-like fishes: Thunnus albacares (yellowfin), T. alalunga (albacore), T. obesus (bigeye), Euthynnus affinis (little tuna), Katsuwonus pelamis (skipjack), Acanthocybium solandri, Auxis spp., Decapterus spp., Trachurops spp., and other species of Scombridae and pelagic Carangidae; (2) dolphinfishes: Coryphaena hippurus and C. equiselis; (3) billfishes: Makaira nigricans (Pacific blue marlin), Makaira spp., Tetrapturus audax (striped marlin), Xiphias gladius (swordfish), and Istiophorus platypterus (sailfish), among others.

TABLE 2-4
MICRONEKTON BIOMASS (WET WEIGHT) IN THE
TROPICAL-SUBTROPICAL PACIFIC

Latitude	Region	Depth Interval (m)	Diel Period	Fish ₃ mg m	Crustaceans mg m	Cephalopods mg m	Others ₃ [*] mg m
40°N	Western Pacific ^a	0-100	Night	2.7	27.9	†	12.7
		0-500	Night	3.6	12.9	†	8.3
		500-1,000	Night	4.7	3.2	†	4.8
30°N	Western Pacific ^a	0-100	Night	2.5	2.1	†	0.8
		0-500	Night	1.8	1.9	†	0.4
15°N to 25°N	Eastern Pacific ^{b,††}	0-100	Night	9.9	9.5	1.2	No Data
		0-400	Day	0.16	0.03	0.05	0.58
	Hawaii ^c	0-400	Night	3.3	1.8	0.3	0.85
		400-1,200	Day	3.1	1.4	0.6	0.7
	Western Pacific ^a	400-1,200	Night	1.6	0.5	0.4	0.55
		0-100	Night	0.4	0.9	†	0.8
Eastern Pacific ^{b,††}	0-500	Night	0.2	0.7	†	0.2	
	500-1,000	Night	0.2	0.6	†	0.1	
5°N to 15°N	Central Pacific ^d	0-100	Night	6.7	7.2	1.6	No Data
		0-500	-	1.7	2.4	0.05	No Data
	500-1,000	-	3.1**	0.6**	0.3**	No Data	
	Western Pacific ^a	0-100	Night	0.5	0.9	†	0.5
		0-500	Night	0.7	1.0	†	0.5
Eastern Pacific ^{b,††}	0-100	Night	7.1	1.8	0.4	No Data	
5°N to 5°S	Central Pacific ^e	0-1,000	-	2.1	1.4	0.2	No Data
		0-100	Night	4.4	1.7	†	1.5
		0-500	Night	1.3	1.0	†	0.6
5°S to 15°S	Eastern Pacific ^{b,††}	500-1,000	Night	0.4	0.5	†	0.2
		0-100	Night	6.5	6.4	0.5	No Data
15°S to 25°S	Eastern Pacific ^{b,††}	0-100	Night	2.1	3.2	0.3	No Data

* Primarily gelatinous organisms

† Combined with "Others" category

** Calculated from median value

†† Converted from displacement volume to wet weight by multiplying by 1.0

Sources: a) Omori, 1974

b) Blackburn, 1968

c) Maynard et al., 1975

d) Hirota, 1977

e) Legend and Grandperrin, 1972

In addition to these larger fishes of commercial and sportfishing interest, many other nektonic species of squids, sharks, flying fish, lancet fish, sunfish, sauries, halfbeaks, etc. are present in oceanic tropical waters (Gooding and Magnuson, 1967; Blackburn, 1976).

Numerous species of marine mammals occur within the OTEC resource areas, including the common dolphin (Delphinus delphis), pilot whale (Globicephala macrorhynchus), spotted porpoise (Stenella attenuata), spinner porpoise (S. longirostris), streaker porpoise (S. coeruleoalba), Pacific white-sided porpoise (Lagenorhynchus obliquidens), Dall's porpoise (Phocoenoides dalli), and bottlenosed porpoise (Tursiops truncatus) which is indigenous to the Gulf of Mexico and Caribbean (Payne, 1978).

2.4.2.5 Endangered and Threatened Species - Many endangered and threatened species are present in the OTEC resource areas. Table 2-5 lists the species and habitats (or known distribution). Most of the species listed are confined to coastal wetlands or small oceanic islands, and have been included because they could be vulnerable to the construction and operation of a land-based OTEC plant. Moored and grazing OTEC plants will potentially affect only oceanic endangered species, none of which are endemic to small regions.

2.4.2.6 Deep-Sea Benthos - Quantitative information on deep-sea benthos is limited in comparison to available data on plankton and nekton in the open ocean. Generalities about deep-sea benthic macrofauna and megafauna include the geographical distribution of biomass (Hessler, 1974), the distribution of biomass with depth (Rowe et al., 1974), the high diversity of deep-sea fauna (Hessler, 1974; Hessler and Jumars, 1974; Jumars, 1976), the postulated importance of mobile scavengers to maintain high diversity by cropping (Dayton and Hessler, 1972), and the extremely slow metabolic rates of organisms in the deep-sea habitat (Hessler and Jumars, 1977).

TABLE 2-5
 ENDANGERED AND THREATENED SPECIES OF OTEC RESOURCE AREAS

Scientific Name	Common Name	Status	Distribution
MARINE MAMMALS			
<u>Balaenoptera musculus</u>	Blue whale	E*	Oceanic, Pacific, Atlantic
<u>Balaenoptera borealis</u>	Sei whale	E	Oceanic, Pacific, Atlantic
<u>Balaenoptera physalus</u>	Finback whale	E	Oceanic, Southern Hemisphere
<u>Eschrichtius gibbosus</u>	Grey whale	E	Oceanic, off western North America
<u>Eubalaena glacialis</u>	Right whale	E	Oceanic, Pacific, Atlantic
<u>Megaptera novaeangliae</u>	Humpback whale	E	Oceanic, Caribbean, North Pacific, Atlantic
<u>Physeter catodon</u>	Sperm whale	E	Oceanic, Caribbean, Pacific, Atlantic
<u>Dugong dugong</u>	Dugong	E	Micronesia, Western Carolines, TTPI**
<u>Trichechus manatus</u>	Caribbean manatee	E	Off Florida, Caribbean
<u>Monachus schauinslandi</u>	Hawaiian monk seal	E	Northwest Hawaiian Islands (NWHI)
<u>Monachus tropicalis</u>	Caribbean monk seal	E	Caribbean (extinct ?)
SEA TURTLES			
<u>Chelonia mydas</u>	Green sea turtle	T*** E	Hawaii Florida
<u>Eretmochelys imbricata</u>	Hawksbill	E	Micronesia, TTPI

TABLE 2-5. (Continued)

Scientific Name	Common Name	Status	Distribution
<u>Dermochelys</u> <u>coriacea</u>	Leatherback	E	Micronesia, TTPI, Caribbean
<u>Lepidochelys</u> <u>kempii</u>	Kemp's ridley	E	Caribbean
<u>Lepidochelys</u> <u>olivacea</u>	Olive ridley	T	Tropical circumglobal
<u>Caretta</u> <u>caretta</u>	Loggerhead	T	Tropical circumglobal
CROCODILES AND ALLIGATORS			
<u>Crocodylus</u> <u>acutus</u>	American crocodile	E	South Florida
<u>Crocodylus</u> <u>novaequineae</u> <u>mindorensis</u>	Philippine crocodile	E	Philippines (and Palau, TTPI?)
<u>Crocodylus</u> <u>rhombifer</u>	Cuban crocodile	E	Cuba (Caribbean?)
<u>Alligator</u> <u>mississ-</u> <u>ippiensis</u>	American alligator	T	Southeastern U.S.
OTHER REPTILES			
<u>Cyclura</u> <u>pinquis</u>	Anegada Island ground iguana	E	Virgin Islands
<u>Cyclura</u> <u>stejnegeri</u>	Mona Island ground iguana	T	Puerto Rico
<u>Ameiva</u> <u>polops</u>	St. Croix ground lizard	E	St. Croix, Virgin Islands
AMPHIBIANS			
<u>Eleutherodactylus</u> <u>jasperi</u>	Golden coqui	T	Puerto Rico

TABLE 2-5. (Continued)

Scientific Name	Common Name	Status	Distribution
BIRDS			
<u>Pelecanus</u> <u>occidentalis</u>	Brown pelican	E	Caribbean, U.S. west coast, Gulf coasts
<u>Puffinus</u> <u>puffinus</u> <u>newelli</u>	Newel's Manx shearwater	T	Hawaiian Islands
<u>Acrocephalus</u> <u>familiaris</u> <u>kingi</u>	Nihoa miller- bird	E	Nihoa, Hawaiian Islands
<u>Psittirostra</u> <u>cantans</u> <u>cantans</u>	Laysan finch	E	Laysan, Hawaiian Islands
<u>Anas</u> <u>laysannensis</u>	Laysan duck	E	Laysan, Hawaiian Islands
<u>Anas</u> <u>wyvilliana</u>	Hawaiian duck	E	Hawaiian Islands
<u>Anas</u> <u>oustaleti</u>	Marianas mallard	E	TTPI, Micronesia
<u>Pterodroma</u> <u>phaeopygia</u> <u>sandwichensis</u>	Hawaiian dark- rumped petrel	E	Hawaiian Islands
<u>Fulica</u> <u>americana</u> <u>alai</u>	Hawaiian coot	E	Hawaiian Islands
<u>Himantopus</u> <u>himantopus</u> <u>knudseni</u>	Hawaiian stilt	E	Hawaiian Islands
<u>Gallinula</u> <u>chloropus</u> <u>sandvicensis</u>	Hawaiian gallinule	E	Hawaiian Islands
<u>Branta</u> <u>sandvicensis</u>	Hawaiian goose	E	Hawaiian Islands

* Endangered

** Trust Territories of the Pacific Islands

*** Threatened

Macrobenthic biomass (retained by 0.42 mm sieve) decreases with depth with extremely low stocks present below 2,000 m depth (Moiseev, 1971; Rowe and Menzel, 1971; Thiel, 1975). Rowe et al. (1974) reported average macrobenthic biomass in the Gulf of Mexico to be 1.3 g m^{-2} on the Continental Shelf, 0.4 g m^{-2} on the Continental Slope, and 0.06 g m^{-2} on the abyssal plain. These values agree reasonably well with values from the Pacific Ocean (Hessler, 1974).

2.4.2.7 Birds - Avifauna within OTEC resource areas are of three major types: (1) oceanic pelagic species (e.g., shearwaters and petrels), (2) coastal and island-associated species (e.g., pelican, gulls, booby) and (3) transitory migrants (e.g., golden plover, Pluvialis dominica) passing through the area. A review of the pelagic distribution of sea birds in the central and eastern Pacific is given by King (1974), including information on the sooty tern (Sterna fuscata), wedge-tailed shearwater (Puffinus pacificus), albatross (Diomedea spp.), and several species of petrels (family Hydrobatidae). Other studies of sea birds around the Line Islands of the central Pacific give lists of species sighted (Gordon, 1970; King, 1955; Waldron, 1964).

2.5 ECONOMIC PROFILES

2.5.1 Data Requirements

In order to penetrate the baseload generating market effectively, OTEC plants must possess advantages over other forms of energy production from technical, economic, legal, institutional, environmental, and functional points of view. Initially, OTEC will be introduced commercially into island communities and will find considerable use. Careful consideration of present populations, economy, natural resources, and power production capabilities of island communities will determine the optimal means for large-scale OTEC development.

2.5.2 Description

Brief descriptions of population, economy, natural resources, and electrical needs of Hawaii, Puerto Rico, and Guam are presented, to serve as a

general economic profile of the communities until more intense studies are prepared prior to OTEC commercialization.

2.5.2.1 Hawaii

(a) Population - The 1977 resident population for the State of Hawaii was approximately 894,700 people. Statewide projections indicate populations of 1,238,700 by 1995 and 1,927,400 by 2020, representing a 38% increase between 1977 and 1995, and a 115% increase between 1977 and 2020.

The population is unevenly distributed throughout the islands; Honolulu County (Island of Oahu) contained more than 80% of the population in 1977 (Figure 2-3). The counties of Hawaii, Maui and Kauai, comprise 9%, 7%, and 4% of the population, respectively. Projected growth rates indicate increases with the same relative distribution percentages. In the next 20 to 40 years, the Counties of Hawaii and Maui will increase to 10% to 12%, and 8% to 9%, respectively, and Kauai will remain static with 4% of the state population.

Of the four counties, Kauai has the most evenly distributed population density. Conversely, the southern half of Oahu accounts for 87% of the island population, whereas the highest density of Maui (71%) is in the central region. The County of Hawaii illustrates another lopsided density pattern with 62% of the people residing in the eastern section, and the majority of these living in and around Hilo. There are no future projections for island density patterns, thus it is assumed that there will be some leveling off, but no great changes, in the existing patterns (Figure 2-3).

(b) Economy - The Hawaiian economy is divided into four major components: tourism, Federal defense expenditures, Federal non-defense expenditures, and agriculture. The last component is the only inherent sector, with the first three being considered export income.

The Gross State Product tripled between 1965 and 1975, rising to \$7.4 billion in 1976. In 1977, visitors spent \$1.8 billion, and defense expenditures were \$1.09 billion. Agriculture contributed the third largest amount, with pineapple and sugar cane production reaching \$162 million and \$227 million, respectively (Schmitt, 1978).

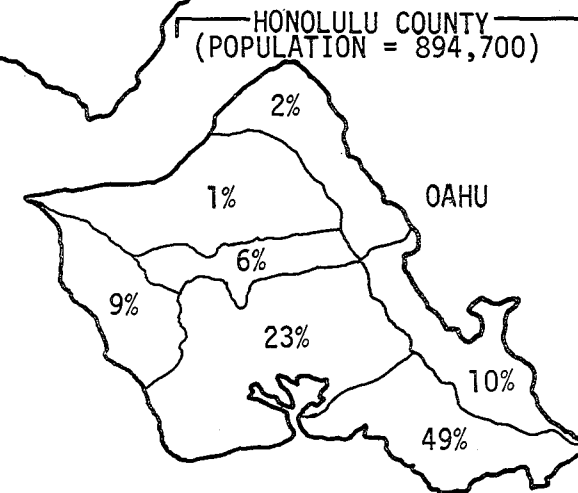
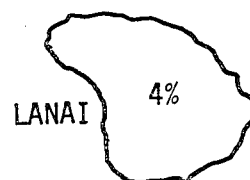
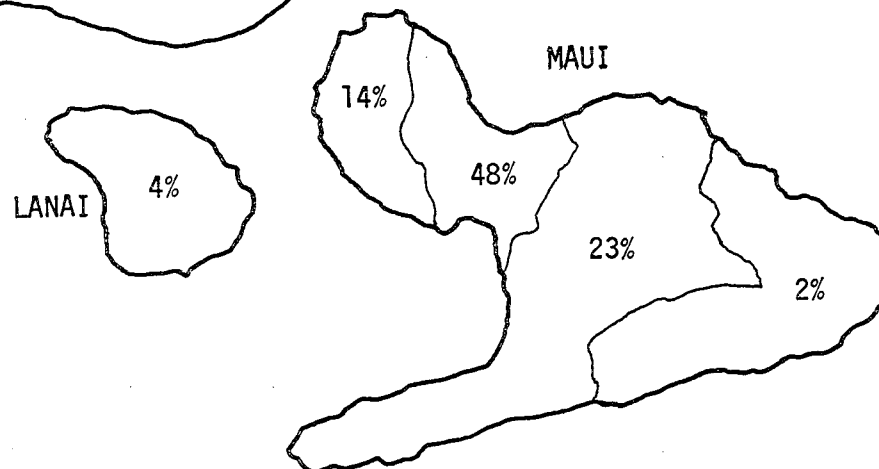
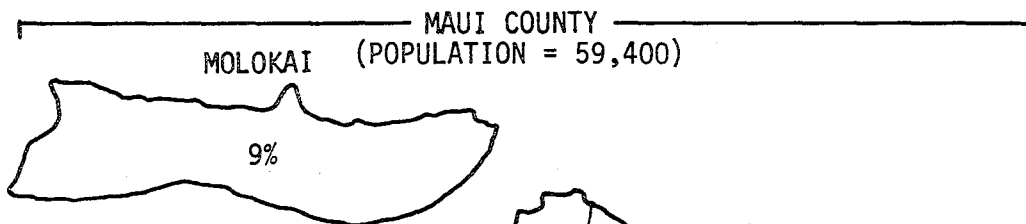
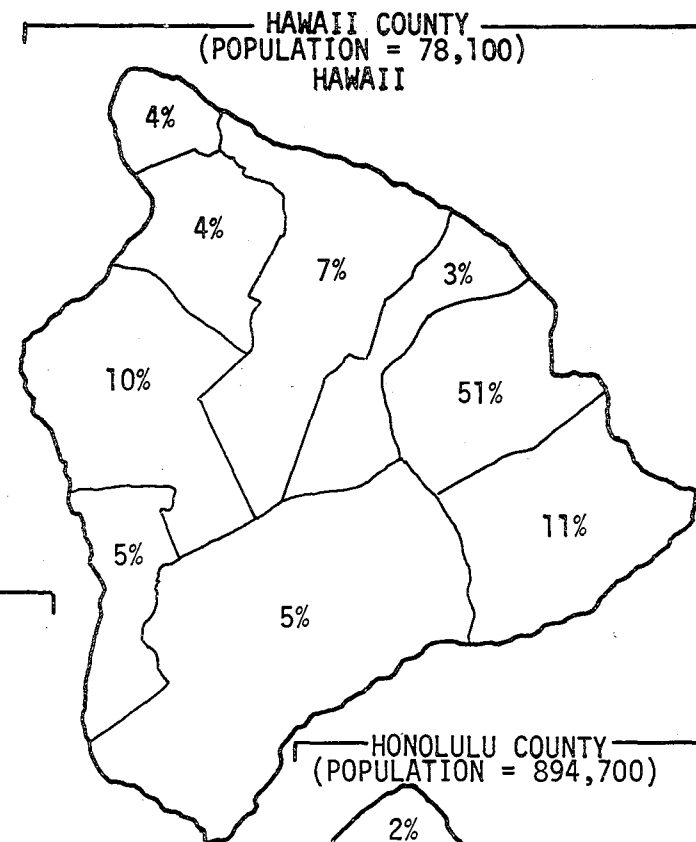
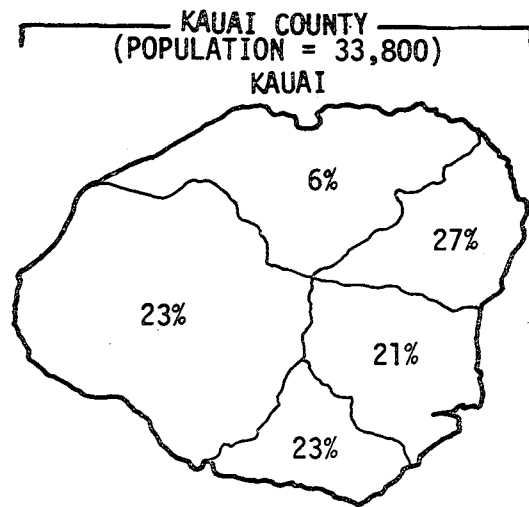

2-22

Figure 2-3. Percent Population Distribution by District (Hawaii)
Source: Schmitt, 1977

The State of Hawaii has developed its State Plan on the premise that tourism will be the major growth industry for the next ten years. In order to achieve a desirable unemployment rate, a 7% growth rate should be maintained until 1980, followed by a 5% growth rate for the next five years. With this guideline, tourism will account for 74% of the new civilian jobs by 1985 (State of Hawaii, 1978). The greatest visitor increase will be on Maui, where growth rate is projected to continue at 10% through 1985. Statewide, the average number of daily visitors is expected to double by 1985, reaching 116,700 people per day. Visitor arrivals for 1985 are projected to be 5.06 million, which will necessitate construction of additional hotel rooms.

(c) Natural Resources - Hawaii's mineral industry is dominated by non-metal construction materials. Masonry and Portland cement products accounted for 90% of the \$50 million worth of mineral production in Hawaii in 1975 (Kerns, 1976). Manganese is the only metal which could play a significant role in Hawaii's mineral industry. Rich offshore deposits of manganese nodules and crust deposits have been discovered, and Hawaii is the closest land where processing could take place. Studies are currently underway to determine the feasibility of such an industry.

(d) Electricity - Hawaii is almost totally dependent upon imported petroleum for its energy source. A natural energy source of geothermal heat exists on the Island of Hawaii, which is presently being studied for its eventual commercial use. Monies were appropriated in 1976 for a water study in Kauai County to investigate the feasibility of power generation in the Wailua River Basin (Kerns, 1976). Some electrical power is being produced by burning sugar cane.

The electrical grid of the Hawaiian Islands is shown in Figure 2-4. The Hawaiian Electric Company projects that one more fossil-fuel-generated electrical plant will be needed. Installed total electric generating capacity in 1977 was 1,482-MW. Electric utility users in 1977 numbered 275,616, with 86% being residential, representing a 40% increase in total customers in the 10 years between 1967 and 1977.

The county of Oahu accounted for the majority of total users (75%), with 179,139 (87%) being residential users. The 1977 average annual use was 7,490 kilowatt-hours (kWh) for residential and 106,474 kWh for commercial/industrial users. Costs per kWh increased from 2.7¢ in 1967 to 5.2¢ in 1977 for residences, and from 2¢ in 1967 to 4.4¢ in 1977 for industrial users. Kilowatt-hour costs are greater in the outlying islands. Residential costs range from 6.7¢ on Maui to 7.9¢ on Kauai. Industrial and commercial user costs ranged from 6.8¢ on Maui to 8.2¢ on Lanai (Stretch, 1979; Schmitt, 1978). In 1977 a total of 5.8 billion kWh were sold at average costs of 5.2¢ and 4.4¢ for residential and industrial users, respectively. No future cost projections are available, however Hawaiian Electric has projected sales ranging from 6.0, to 6.9 billion kWh for the years 1980 to 1985 (Stretch, 1979).

2.5.2.2 Puerto Rico

(a) Population - Puerto Rico's Department of Labor estimated the 1978 population to be 3.3 million people. More than half of the population resides in San Juan and the immediately surrounding regions of Bayamon, Caguas, and Carolina. One third of the population resides in the west and the southwest to south-central regions of Mayaguez and Ponce, respectively. Projected regional estimates for 1995 and 2000 indicate greatest density increases in the regions surrounding San Juan. Bayamon shows the greatest variance, increasing 78% between 1978 and 1995, and 6.5% from 1995 to 2000. Carolina is second in increases, with a 56% raise between 1978 and 1995 and an 8% increase from 1995 to 2000. Total populations for 1995 and 2000 are projected to be 4.6 and 4.7 million persons, respectively (Pinsky, 1979). This is an increase of 39.3% from 1978 to 1995 and 43.9% from 1978 to 2000.

(b) Economy - During the last thirty years, Puerto Rico changed from an agrarian economy to an industrialized, urbanized society. Industrialization began in the early 1950's, with the introduction of a heavy chemical industry based on cheap, imported crude oil. Since 1950, employment in agriculture has dropped from 36% to 6.6%. The greatest increase in employment has been in local government, from 7.5% in 1950 to 20.4% in 1975 (DOC, 1972).

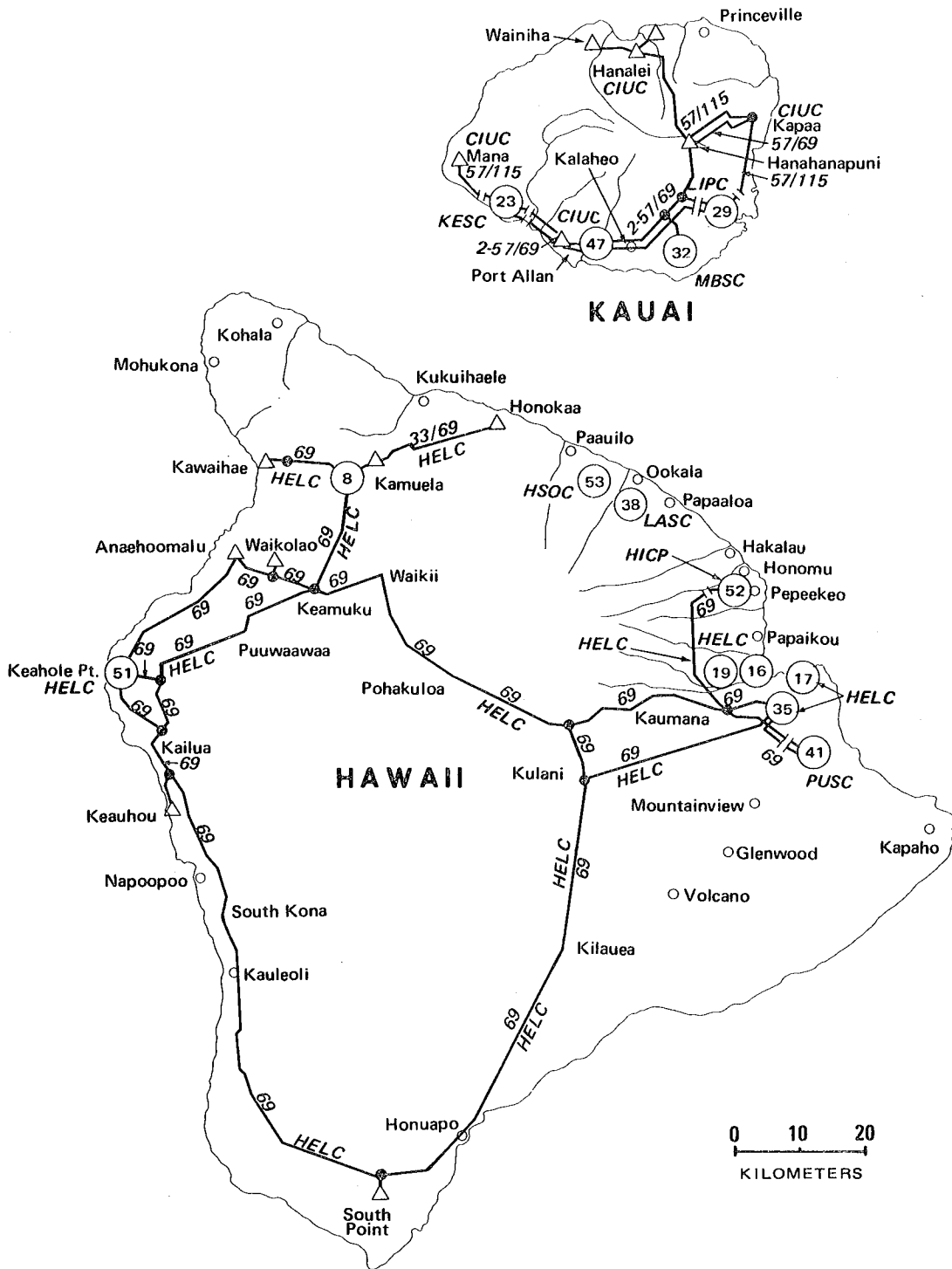

○ = FOSSIL GENERATING PLANT
 NUMBER WITHIN PLANT SYMBOL REFERS TO STATE PLANT LIST.

Figure 2-4. Electrical Power Grid--Hawaii
 Source: DOE, 1978b

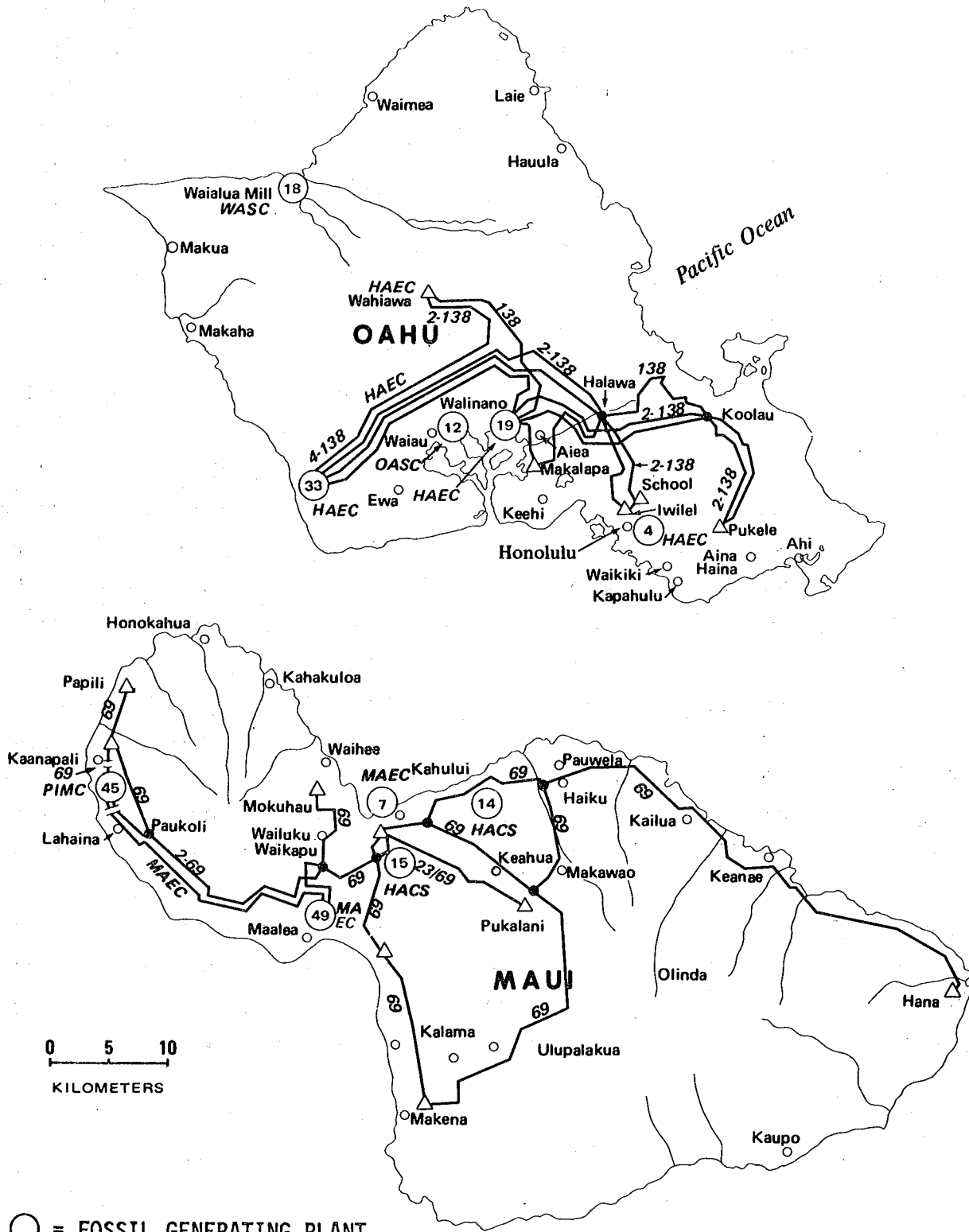

Figure 2-4. (continued)

The largest contributor to the economy in 1978 was industry, which made up 42% of the total Gross National Product (GNP) of \$8.939 billion. Since 1960, industry has grown tenfold. Between 1970 and 1978, the Manufacturing Gross Product (a measure of industrial growth) tripled. The intensive growth experienced in the 1960's is due to Puerto Rico's advantages of low wages and a favorable business climate as compared to the mainland. Manufacturing Gross Product is projected to increase 33% by 1981, when industry will contribute \$5.026 billion to Puerto Rico's GNP.

Puerto Rico's economy is highly sensitive to the U.S. mainland, because the U.S. is the main importer of goods and services. In 1977, \$3.5 billion worth of goods were imported to the island; the majority included food, live animals, and manufactured goods. In turn, Puerto Rico exported \$3.9 billion worth of goods to the U.S. in 1977, a third of which were chemical products. Unemployment continues to be a major problem, running 18.8% in 1978. The largest growth industry in 1979 is predicted to be the construction industry.

(c) Natural Resources - There is no significant mining industry in Puerto Rico, except for construction materials. Commercially valuable copper deposits exist in the central mountain area but have not yet been exploited. There are no deposits of coal or natural gas; however, some oil exploration is beginning, with drilling to commence in January 1980.

The principal port of Puerto Rico is San Juan, located on the north coast. Four major ports are located on the south coast. Three of the four are petrochemical ports, namely Guayanilla, Yabucoa and Las Mareas. Guanica, on the southwestern coast, specializes in grain and chemical handling (DOC, 1972).

(d) Electricity - Puerto Rico depends upon imported petroleum for 98% of its electrical power generation; hydroelectric power accounts for the other 2% (Marina, 1979). Continued efforts to build a nuclear power plant are being thwarted by environmental problems in prospective sites (Pinsky, 1979). Existing power plants have a maximum generating capacity of 4,199-MW, and a dependable capacity of 4,187-MW. The total system of plants and transmission lines is illustrated in Figure 2-5.

The peak load for 1978 was approximately 2,249-MW. A 38.9% increase is projected for 1984, and a peak load of 2,800-MW is anticipated.

During the year ending June 30, 1978, the average cost per kWh was 6.09¢ for residential users, 4.37¢ for industrial users, and 6.92¢ for commercial users (Pinsky, 1979).

2.5.2.3 Guam

(a) Population - A 1978 study by the Guam Bureau of Planning estimated the population to be 98,000 people, including 22,000 military personnel. A conservative projection for the year 2000 indicated a doubling of the civilian population with the military remaining constant. The population is increasing, but at a declining rate (Pinckert and Associates, 1978).

Guam is geographically divided into three major zones. The northern portion is a limestone plateau where 45% of the population lives. This area has good beaches, available water, and a flat terrain, making it an attractive location for industry, tourists, and residents. Central Guam supports 30% of the population and is the location of Agana, Guam's major trade, government, and religious center. This is the most urbanized area of Guam. Southern Guam is mostly volcanic and supports only 25% of the population (DOC, 1979a).

(b) Economy - Guam's economy is similar to Hawaii's, and dominated by the Federal Government and the tourist industry. Construction and retail and wholesale trade activity are the primary economic components. Retail and wholesale trade activities provide the greatest employment and gross receipts in the private sector, whereas the tourist industry contributes the majority of privately generated revenue (\$8 to \$10 million). Other major sources of revenue come from income taxes and Federal grants (DOC, 1979a). Manufacturing, agriculture, and fisheries are the remaining industries.

(c) Natural Resources - The only raw material in Guam is limestone, which is crushed and used for aggregate (Sweeny, 1975). The only commercial port is located on Cabras Island, the port of Guam. An average of 700,000 tons of cargo are offloaded yearly; present facilities are inadequate, and expansion

ATLANTIC

OCEAN

2-29

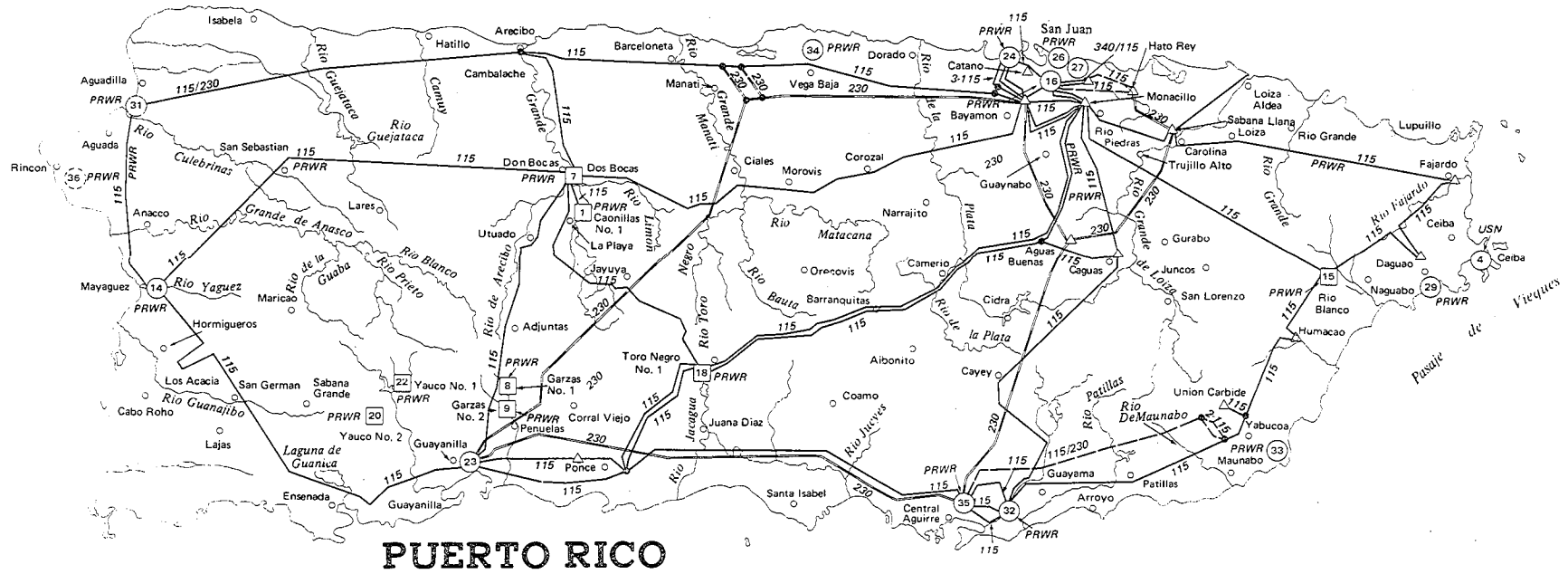

PUERTO RICO

0 8 16 32 KILOMETERS

Caribbean Sea

- = FOSSIL GENERATING PLANT
- = HYDROELECTRIC GENERATING PLANT
- NUMBER WITHIN PLANT SYMBOL REFERS TO STATE PLANT LIST.

Figure 2-5. Electrical Power Grid--Puerto Rico
Source: DOE, 1978b

of the port is planned (DOC, 1979a). There is no problem with fresh water availability on Guam, as there is a limestone aquifer which provides the necessary supply.

(d) Electricity - Presently, Guam has 273.5-MW available for normal operation. This power is provided by a combination of steam- and diesel-powered plants. The 1978 demand was 160-MW, leaving 22.5-MW for future load growth after allowing for maintenance outages and forced outages. Pinckert and Associates (1978) devised a formula to project energy needs based upon present day demands, retirement of functional plants, and a 3% to 5% increase in electricity demand per year. The conservative result of this formula projects that, by 1994, construction of two 66-MW plants in combination with some capacity retirement will accommodate Guam's power demand. Power-generating facilities will be situated on Cabras Island. Plants of the 66-MW size will be available in about 10 years.

Guam is totally dependent upon imported oil and there is no present plan to reduce this dependency. Guam has a refinery which processes foreign crude oil. The Coastal Zone Management Draft EIS states that this refining capability mitigates the impact of dependency on foreign oil. There are plans to expand the refinery from 35,000 bbl/day to 50,000 bbl/day (Pinckert and Associates, 1978).

2.6 OTEC INDUSTRIAL FACILITIES

2.6.1 Data Description

The integration of OTEC industrial facilities into existing markets for ammonia and aluminum production is very complex, requiring serious consideration of technical, economic, legal, institutional, and environmental issues. Insufficient information is available to evaluate issues for this initial programmatic EA. A brief review of current information on the relationship of OTEC plant-ships to ammonia and aluminum production follows.

2.6.2 Description

2.6.2.1 Ammonia - The raw materials for the production of ammonia by OTEC plants will be produced aboard the plant-ships: hydrogen, by electrolysis of desalted seawater, and nitrogen, by liquifaction and fractional distillation of air (EPA, 1977). The ammonia will be produced and stored onboard the platform prior to shipment to land-based facilities. The distances from the OTEC resource areas to the west, Gulf, and east coasts of the United States are shown in Figure 2-6.

The U.S. is expected to increase the importation of ammonia in the future. The U.S. market for ammonia is centered in the farmlands near the Mississippi and adjoining rivers, and comprised 78% of the 1975 market. The port of entry for ammonia for the area is New Orleans. The western states represented 13% of the 1975 ammonia market. Four deep-draft ports serve this region: Los Angeles, San Francisco, Portland, and Seattle.

The eastern states used 2% of the 1975 ammonia market. A number of deep-draft harbors serve this area, including New York, Baltimore, Charleston, Savannah, and Tampa (Francis, 1977).

2.6.2.2 Aluminum - Aluminum is obtained from its naturally occurring ore, bauxite, by extracting alumina from the ore and reducing the alumina to aluminum. The distances from the major bauxite resource areas to the OTEC thermal resource areas, the distances from the thermal resource areas to the west, Gulf, and east coasts of the United States, and the major deep-draft harbors closest to the bauxite resource areas and aluminum smelting plants in the U.S. are illustrated in Figure 2-6. The greatest number of aluminum smelting plants occurs in the southern U.S., although other plants exist throughout the country.

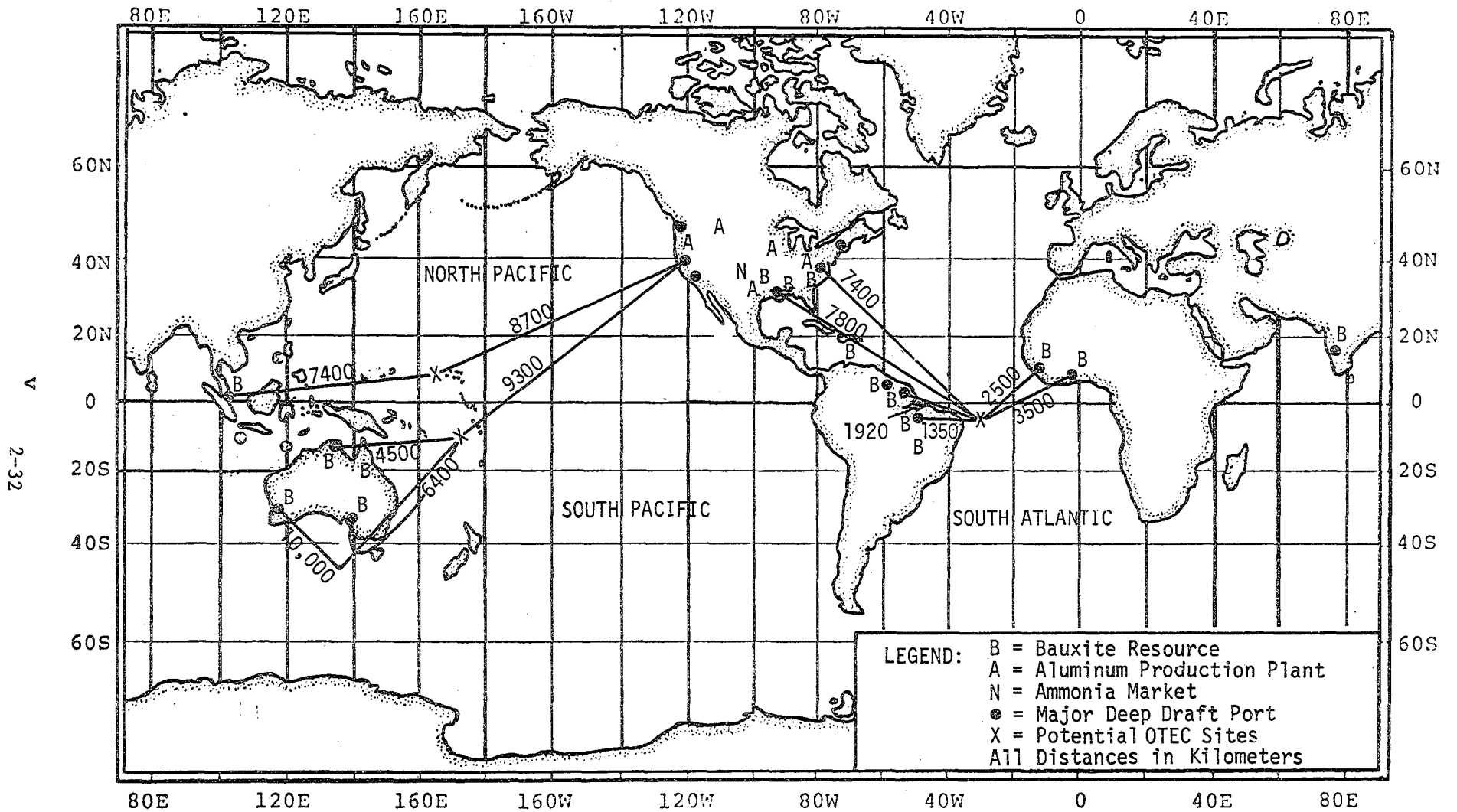

Figure 2-6. Ammonia and Aluminum Plant-Ship Resources

Chapter 3

POTENTIAL ENVIRONMENTAL IMPACTS

The full range of environmental issues surrounding OTEC development, demonstration, and commercialization were described in the DOE OTEC Environmental Development Plan (DOE, 1979a). OTEC platforms may affect air quality, land-use plans, and the marine ecosystem.

Measurable atmospheric or climate effects may result from the cooling of sea surface temperatures and carbon dioxide releases. Industrial plants may emit processing emissions into the atmosphere. These impacts are considered in Section 3.1.

Land-use changes may result from the establishment of coastal OTEC facilities (Section 3.2).

The principal impact of OTEC platforms will be on the marine ecosystem. Large volumes of warm and cold water will be redistributed throughout the water column during power production. Trace elements and compounds will be released, and may be toxic to biota. A thorough discussion of potential impacts on the marine environment is presented in Section 3.3. Economic effects are discussed in Section 3.4. An overview of OTEC environmental studies, which are in progress or required in the future, is presented in Section 3.5.

3.1 ATMOSPHERIC EFFECTS

OTEC operations may affect the atmosphere in two broad categories: (1) air quality (from ammonia or aluminum production) and (2) climatic alterations (due to cooling of surface waters and release of carbon dioxide).

3.1.1 Industrial Releases

3.1.1.1 Ammonia Plants - The production of ammonia, ammonia-based fertilizers, and related products, such as nitric acid, by an OTEC plant-ship, will

use the Haber process (DOE, 1977a). This process differs from land-based processes because it does not produce sulfur or carbon-based byproducts, since the generating products (e.g., natural gas, intermediate petroleum fractions, or coal gasification products) are not used. Instead, ammonia will be produced by combining the elements nitrogen and hydrogen in pure form. Nitrogen will be extracted from the atmosphere by means of liquefaction and fractional distillation, and hydrogen will be produced by electrolysis of desalinated seawater (DOE, 1977a).

Nitric acid will be manufactured by air oxidation of ammonia. Ammonium nitrate is formed by combining nitric acid and ammonia. Production of ammonium phosphate will necessitate phosphate rock shipments from shore.

It is not anticipated that ammonia production will cause significant pollutant emissions into the atmosphere. Processing facilities will be required to use scrubbers which satisfy EPA criteria for pollutant emissions.

3.1.1.2 Aluminum Refining - Aluminum is manufactured in two steps: (1) extraction of aluminum oxide from bauxite (using the Bayer process), and (2) electrolytic reduction of the oxide to free metal. The extraction process is not energy-intensive and (because of the large volumes of bauxite refined to obtain the aluminum oxide) will likely be done on shore. The electrolytic reduction of aluminum oxide to the free metal is achieved by one of two methods: drained-cathode Hall process or the new Alcoa process. The gaseous byproducts of each process are carbon dioxide and carbon monoxide (DOE, 1977a). The aluminum production facilities must satisfy EPA air quality criteria and employ the best available technology. Atmospheric releases will occur far offshore and winds will dilute the gases.

3.1.2 Climatic Effects

3.1.2.1 Sea Surface Temperatures - OTEC plant operation can be expected to decrease the sea surface temperature (SST). The extent of change will be determined by the plant size, distribution and discharge. Decreases in temperature are due to two related aspects of plant operation: First, large quantities of cold water will be brought to the surface for use in the plant's

condenser units. After use, the water will be discharged into the surrounding water column where at least part of the cold effluent will be advected through the mixed layer. Secondly, large quantities of warm water will be drawn across the evaporators and be cooled by several degrees Celsius before being discharged to the receiving waters. At least some of this cooler warm water will be advected through the mixed layer.

Using an advection model, Bathen (1975) investigated the area of heat loss associated with the operation of various sizes of OTEC plants operating off the big island of Hawaii during summer and winter. A moored 100-MW plant would change the temperature of the mixed layer by 0.24°C to 0.33°C in summer. The impacted area of this temperature anomaly varies from 3.5 km² to 11 km², dependent upon the presence or absence of currents. A 240-MW OTEC plant would cause an SST anomaly of 0.54°C, which would cover an area of 42 km² under summer conditions in the presence of northward advection. These temperatures are above the natural diel temperature fluctuations of 0.1°C to 0.3°C (Bathen, 1975).

Estimates of SST depression due to the operation of one thousand 200-MW plants in the Gulf of Mexico indicate that the SST will decrease by about 0.3°C over the entire Gulf of Mexico (Martin and Roberts, 1977). Most of the temperature decrease is predicted to occur during the first year of operation. Similar calculations for one hundred 200-MW plants indicate that an SST depression of about 0.05°C may occur. The scenario for the Gulf of Mexico of one hundred forty-six 400-MW plants lies between these two projections; a temperature decrease of about 0.1°C to 0.15°C may occur. The large-scale wide-basin model in preparation by Dynalysis of Princeton, under Department of Energy funding, will provide further information on projected SST depressions which may occur over large ocean areas. The determination of climatic effects due to OTEC plant and park operations has not been ascertained at this time; further in-depth studies are necessary.

Namias (1979) determined that SST anomalies of 0.6°C over a large ocean area (1,000 to 2,000 km² between 20°N and 60°N latitude) have affected the weather pattern for North America. He also reported that SST anomalies have caused the high-pressure zone (usually located 1,800 km offshore of the west coast of North America) to move inshore. Moving the high pressure zone caused

storm tracks to move further south, and more parallel to the coasts of California and Oregon, than were historically normal. Many other examples of coupling SST's with the atmosphere are described in Barnett (1978), Davis (1978), and White and Haney (1978).

3.1.2.2 Carbon Dioxide - The earth's atmospheric carbon dioxide (CO₂) concentrations are increasing (Brewer, 1978). This increase, coupled with the ability of the carbon dioxide molecule to absorb radiation at certain wavelengths while transmitting others, has aroused the concern of environmental scientists.

Carbon dioxide is transparent to the majority of the incoming solar radiation spectrum. The high-energy, short-wavelength radiation passes through the atmosphere and warms the earth below. The earth, in turn, reradiates energy towards space in longer wavelengths. Carbon dioxide is opaque to longer wavelengths, thus causing absorption of energy and warming of the atmosphere. After increased warming, the wavelengths shift toward shorter wavelengths consistent with Planck's law of black body radiation. With increasing temperature and decreasing wavelengths, carbon dioxide becomes more transparent to the reradiated energy, until equilibrium is reached where incoming radiation equals outgoing radiation and an average global temperature is maintained. It is believed that increases in atmospheric carbon dioxide levels will shift the equilibrium temperature of the planet, such that average global temperatures will increase.

The atmospheric carbon dioxide concentration before the industrial revolution is not exactly known, but Brewer (1978) suggests a preindustrial concentration of 270 to 290 ppm as a responsible estimate. Present-day levels are about 300 ppm. The increase is mainly due to the burning of fossil fuels; additional sources include the production of cement and large-scale agricultural undertakings. About 50% of the carbon dioxide releases remain in the atmosphere. The fate of the other half is not known, but it is believed that much is stored in the world's oceans.

The seawater chemistry of carbon dioxide is quite complex. In the oceans, carbon dioxide exists in equilibrium with carbonate (CO_3^{-2}), bicarbonate (HCO_3^-), and carbonic acid (H_2CO_3) according to (Boot 1974).

Factors which govern the saturation concentration of carbon dioxide, in decreasing order of importance, are hydrostatic pressure, carbon dioxide concentration, temperature, and salinity (Wangersky, 1969). A decrease in depth, with increases in temperature and salinity, will decrease the ability of a parcel of water to hold carbon dioxide in solution, and a net outgassing of carbon dioxide will occur. For these reasons, the operation of a large-scale OTEC plant, which will bring great volumes of cold, carbon dioxide-rich water to the surface, has a potential for impact.

An attempt to quantify the carbon dioxide released as a consequence of OTEC operations can be made by assuming that the amount of carbon dioxide contained in the deep water which exceeds the carbon dioxide in surface waters would be liberated.

The amount of carbon dioxide efflux from a variety of 400-MW OTEC configurations has been estimated to range from 1.49×10^6 kg day⁻¹ to 2.56×10^6 kg day⁻¹ (Appendix C). The range of carbon dioxide efflux from 146 OTEC plants would thus range from 2.18×10^8 kg day⁻¹ to 3.74×10^8 kg day⁻¹. These are probably overestimates, since all excess carbon dioxide may not be released. For comparison, a typical 400-MW coal-fired power plant produces about 8.6×10^6 kg carbon dioxide day⁻¹, which is over 4 times the carbon dioxide which a 400-MW OTEC plant produces. (Ditmars, 1979). However, the siting of OTEC plants in a relatively small area may have regional effects.

In general, the operation of an OTEC plant will produce less carbon dioxide than a similarly sized coal-fired plant. Such releases of carbon dioxide are not expected to cause significant large-scale effects on climate; microclimate effects may occur, however. The carbon dioxide-climate relationship is not fully understood and future studies will provide information on this phenomenon.

3.2 LAND IMPACT ISSUES

A feasibility design study for 10- to 40-MW land-based OTEC plants was prepared for two specific locations: Keahole Point, Hawaii, and Punta Yeguas, Puerto Rico (Brewer et al., 1979). The overall areal requirement for plant construction was not presented; however the intake pipes for the water supply were projected to range from 6.5 m to 7.5 m in diameter for a 10-MW plant. These intake pipes extend from the plant to the ocean and would be entrenched several meters below ground to the 30 m depth contour.

Virtually no terrestrial data have been collected which describes the flora and fauna at the potential OTEC sites. The construction of a land-based plant would necessitate the total destruction of the existing habitat and potentially affect coastal marine resources (i.e., coral reefs). Because of the paucity of field data, terrestrial ecology variability at the candidate islands and insufficient plant design detail, an assessment of impacts cannot be performed. A brief overview is presented on the coastal zone and discharge requirements.

3.2.1 Coastal Zone

The siting of land-based OTEC plants or shore-based distribution points will have to be in general agreement with the State's Coastal Zone Management Plans (CZMP). Coastal zone plans have been prepared for Guam, Hawaii, Puerto Rico, and the Virgin Islands (Guam: DOC, 1979a; Hawaii: DOC, 1978; Puerto Rico: DOC, 1972; Virgin Islands: DOC, 1979b;). Most of the CZMP's include OTEC as an energy production technology option for the future.

3.2.2 Discharges

As with other types of OTEC plants, land-based plants must obtain National Pollutant Discharge Elimination System permits for the discharge of cold and warm waters. Intakes must comply with Section 316(b) of the Clean Water Act and Amendments (1977); it will be necessary to demonstrate that intake designs represent the best available technology, and that no adverse environmental impacts are occurring (DOE, 1979b).

3.3 WATER ISSUES

Environmental issues which may affect the oceanic environment due to large-scale OTEC development can be related to specific components of the plant. The components and possible impacts include:

- Platform Presence
 - Biota attraction
 - Protective hull coatings release
 - Sanitation discharges
 - Mooring and cable implantation

- Warm and Cold Water
 - Withdrawal
 - Organism impingement
 - Organism entrainment

- Water Discharge
 - Ocean water redistribution
 - Biocide release
 - Working fluid release
 - Trace constituent release
 - Detrital releases

The effects listed above will primarily impact the biological community. The organisms inhabiting the OTEC resource area are oceanic in nature and have adapted to a stable, pristine environment. Slobodkin and Sanders (1969) hypothesized that organisms adapted to stable, predictable environments would be more "fragile" or vulnerable to environmental stress than organisms adapted to unstable, unpredictable environments. This effect has been demonstrated for the lower food chain members (Fisher et al., 1973; Fisher, 1977).

In order to facilitate a clear discussion, the biological community is divided into the following categories:

- Phytoplankton
- Zooplankton (microzooplankton and macrozooplankton)
- Micronekton (mesopelagic fishes, cephalopods, crustaceans, and larger fish larvae)

- Nekton
- Marine Mammals, Reptiles, and Birds
- Benthos

The environmental issues affecting each biological category are summarized in Table 3-1.

3.3.1 Approach

The approach to assess the magnitude and extent of potential impacts is based upon qualitative and quantitative discussions. Different OTEC platform configurations will be considered, including:

- 40-MW open- and closed-cycle platforms
- A 400-MW closed-cycle platform
- An OTEC "Cluster" (eight or nine 400-MW closed-cycle moored platforms)
- An OTEC Park (18 OTEC clusters)

Each case will be superimposed on a typical tropical-subtropical oceanic environment, and estimates of the biota losses associated with the impacts will be calculated. In order to assess regional effects of OTEC Park operation, the estimated biota losses will be compared to the eastern Gulf of Mexico OTEC resource area (defined as the region in which the delta t is at least 20°C each month).

3.3.2 Platform Effects

3.3.2.1 Attraction - Fish congregate around offshore structures, presumably for food and protection (Hastings et al., 1976; Gooding and Magnuson, 1967). Lights are also an attractive force at night. Consequently, OTEC platforms are expected to act as artificial reefs and provide a habitat for a large number of organisms. The increases cannot be estimated because they are functions of the site, the structure design, the illumination of lights, original population size and composition, and the natural history of the

TABLE 3-1
POTENTIAL BIOLOGICAL IMPACTS RESULTING FROM OTEC
DEPLOYMENT AND OPERATION

Issue	Biological Community Divisions							
	Phyto- plankton	Micro- zooplankton	Macro- zooplankton	Gelatinous* Organisms	Micro- nekton	Nekton	Mammals, Birds	Benthos
Platform								
Biota Attraction Structure Lights			X		X	X	X	
Protective Hull Coatings Release	X	X	X	X	X	X	X	
Sanitation Discharges	X	X	X	X	X	X	X	
Mooring/Cable Implantation								X
Cold & Warm Water Withdrawal								
Impingement				X	X	X		
Entrainment	X	X	X					
Water Discharge								
Water Redistribution	X							
Biocide Release	X	X	X	X	X	X	X	
Working Fluid Release	X	X	X	X	X	X	X	
Trace Element Release	X	X	X	X	X	X	X	
Detrital Release								X

* Coelenterates, salps, ctenophores

organisms (DOE, 1979c). Therefore, an approximation is made to illustrate the multiplicative power of attraction on impacts. The attraction factor as a result of platform presence is assumed to be two times the ambient biomass; attraction to lights is presumed to cause an additional twofold increase in biomass at night near the surface.

3.3.2.2 Hull Coating Releases - Protective hull coatings consist of a matrix containing a soluble toxic compound: the toxin either diffuses out of the matrix, or the entire coating gradually erodes, exposing a fresh toxic surface. The salts of heavy metals (Cu, Hg, Zn, As) have the most effective long-term leaching rates. Typical release rates of cuprous oxide average about $30 \text{ ug cm}^{-2} \text{ day}^{-1}$ (De et al., 1976). Heavy-metal based coatings require protective primer coats prior to application of antifouling paint to prevent galvanic corrosion.

No available data exists for toxicity of copper, mercury, zinc, and arsenic in invertebrates or fishes likely to inhabit the tropical-subtropical oceanic regions (EPA, 1976a). However, the oceanic environment where OTEC platforms will operate is characteristically very stable. The organisms are not exposed to, and cannot tolerate, any great degree of stress when compared to hardy coastal organisms. Difficulty in culturing these organisms in the laboratory and lack of purpose has previously discouraged toxicity testing. In 1978, the Department of Energy contracted with Gulf Coast Research Laboratories (GCRL) to perform toxicity studies for OTEC releases (e.g., titanium, chlorine, ammonia) on oceanic zooplankton and fish. The results of these studies in connection with the monitoring of the preoperational test platform (OTEC-1) will provide further information.

In the past, toxic organic compounds which do not require undercoating have achieved greater use. Organotin, organolead, organotinfluorides, and tributyl tin oxides were proven more effective as antifoulants than commonly used heavy metal salts; however, the potential effects on the marine environment are not known and warrant further investigation.

The EPA (1976a) established allowable limits for some toxic substances (e.g., mercury) used in hull coatings because of the potential threat to the

environment. When considering the release rate, the surface area of the hull and flow past the platform are important. Conservatively assuming a 400-MW OTEC plant has a surface area of about 32,000 m², a park of OTEC plants would release 1.4 x 10³ kg of hull coating each day. This release rate is comparable to a concentration of 2.7 ug m⁻³ in the surface to 60 m depth layer of the eastern Gulf of Mexico OTEC resource area. The effect of these low level continual releases is not known; but bioaccumulation could pose a hazard to sport or commercial fishes.

3.3.2.3 Sanitation Releases - OTEC platforms will comply with U.S. Coast Guard Regulations for sanitation releases. Hence, all sewage from OTEC plants will be collected and processed in a U.S. Coast Guard certified aerated biological unit before discharge overboard (DOE, 1979c). As an estimate, approximately 25 persons will man each OTEC plant and each person will generate about 0.38 m³ (100 gallons) of waste water each day. Since the 10 m³ of sewage produced each day is treated prior to discharge and rapid mixing and dilution occurs after discharge, the effect from release in the open ocean is expected to be negligible.

3.3.2.4 Mooring/Cable Implantation - The mooring of an OTEC plant and cable transmission to shore is a potential impact that OTEC will impose on the benthic community. One plant-to-shore cable transmission design entails tethering the plant to a large subsurface buoy, thus limiting dynamic cable stress and benthic scouring by the mooring cable (Pieroni et al., 1978). Assuming that scouring disrupts the benthic community 100 m from each anchor, then an OTEC park of 146 plants will affect 0.05% of the benthic community in the eastern Gulf of Mexico OTEC resource area. Therefore, the impacts resulting from mooring deployment will be insignificant.

Cables will be laid on the ocean floor (Morello, 1978) and cause minimal disturbance of benthic life. From the 100 m contour to the land distribution point, cables will be implanted 2 to 3 m into the substrate and benthic community disturbances will result. The effects of cable implantation include temporary, localized increases of water column turbidity and habitat destruction. Effects of embedding the cable will affect organisms along the

narrow cable route. Thus, insignificant impacts will occur if resource regions, coral reefs, spawning grounds and other environmentally unique areas are avoided.

3.3.3 Warm and Cold Water Withdrawal

OTEC platforms will withdraw approximately 100 times more water than a similarly sized nuclear powered plant. The major impacts associated with the withdrawal of large volumes of warm and cold water are impingement of organisms on the intake screens and entrainment of organisms through the OTEC plant. An evaluation of the effects of impingement and entrainment by various types and numbers of OTEC plants is presented in the following paragraphs. A complete description of the calculations and methods employed to make these estimates appears in Appendix C.

3.3.3.1 Impingement - Impingement of organisms will be one of the most visible effects of OTEC operation on the marine environment. Impingement is also a plant operational concern, due to high maintenance costs of intake screen cleaning and plant downtime.

Screen mesh size, volume of water circulated, and biomass concentrations are primary factors in impingement impact evaluation. The exact screen mesh size for OTEC plants is not known, however a generally accepted criterion is that mesh size should equal half the diameter of heat exchanger tubes (EPA, 1976b). The heat exchanger tube size for the preoperational platform (OTEC-1) is 2.5 cm; larger OTEC power plants will probably have heat exchanger tubes of similar size. Therefore, the screen mesh size should be about 1.3 cm. The length of organisms impinged on an intake screen is usually three times the size of the screen mesh, although fish shapes may alter this generalization somewhat (Ray et al., 1976). Thus, organisms larger than about 4 cm in length and with limited avoidance capabilities may be impinged on the cold or warm water intake screens.

The only available information on organisms with the above characteristics is obtained from midwater trawl collections. The intake velocities for OTEC plants (50 to 100 cm sec⁻¹) are less than towing speeds of midwater trawls

(100 to 200 cm sec⁻¹), however the species and quantities of organisms which will be impinged on OTEC screens will probably resemble those caught in midwater trawls (Nath et al., 1977). This is primarily due to velocity being less significant than volume as a factor (EPA, 1976b; Edwards et al., 1976). Therefore, the organisms which will be most affected by impingement include small epipelagic fish, mesopelagic fish, macroplanktonic crustaceans (penaeid and caridean shrimps, mysids, large euphausiids), and cephalopods. Nekton will occasionally be impinged on the warm water intake screens. Herbinson (1979) reports that an average of 100 nektonic fish are impinged daily during the normal operation of several coastal power plants in Southern California. However, nekton impingement on OTEC screens cannot be evaluated due to insufficient information on nekton standing stocks and behavior.

Impingement rates will vary with the time of day. Maynard et al. (1975) offers the only available data on the day and night biomass of micronekton at various depth intervals in the tropical-subtropical oceanic environment. It was found that the upper 400 m of a 1,200 m water column had an average micronekton biomass of 0.24 mg m⁻³ during the day, and 5.4 mg m⁻³ at night, on a wet weight basis. Between 400 and 1,200 m, the micronekton biomass averaged 5.1 mg m⁻³ during the day, and 2.5 mg m⁻³ at night. These values will increase around OTEC plants due to platform attraction effects.

The large gelatinous bodies of coelenterates, salps, and ctenophores constitute the greatest potential impingement problem, since they lack the motile ability to avoid the intakes. Using data from Maynard et al. (1975) on "other invertebrates", which are primarily gelatinous forms, an average biomass of 0.58 mg m⁻³ is present in the upper 400 m during the day, and 0.86 mg m⁻³ at night. Between 400 and 1,200 m, gelatinous organisms have an average biomass of 0.69 mg m⁻³ during the day, and 0.55 mg m⁻³ at night, measured on a wet weight basis. Gelatinous organisms are not expected to be attracted by the structure or lights.

Estimates of the micronekton and gelatinous organism biomass impinged each day on the warm and cold water intakes of various OTEC plants are shown in Table 3-2. Impingement will be a relatively greater problem at the warm water intake than at the cold water intake, because gelatinous organisms are more

abundant in surface waters than in deep waters, and micronekton are attracted to surface lights. The micronekton biomass will probably be slightly reduced downstream of single or multiple OTEC plants; however, the affected area will determine the extent of the impact. A single 400-MW OTEC plant will impinge almost 1,400 kg of micronekton biomass each day. This impingement rate will reduce the population in a localized area downstream of the plant, but the ecological impact of the loss is probably insignificant, because of the replacement ability of the micronekton population in the surrounding oceanic region and the migration abilities of the nektonic organisms which prey upon the micronekton. However, a park of OTEC plants will impinge over 300,000 kg each day, and reduce the micronekton biomass over a large oceanic region. This impingement rate is roughly comparable to reducing the potential nekton production by 1.0% in the eastern Gulf of Mexico OTEC resource area. Unfortunately, the long-term effect of impingement on the oceanic ecosystem cannot be evaluated further, due to an incomplete understanding of the marine food chain.

3.3.3.2 Entrainment - Marine organisms less than 4 cm in size will be withdrawn from the water column and entrained in the seawater flowing through the heat exchangers. Organisms between 1.25 and 4 cm may be impinged for a short time before being extruded through the screen. The entrained organisms at the warm water intake of an closed-cycle OTEC plant will be subjected to chlorine and the physical abuse (acceleration, impaction, shear forces, and abrasion) associated with passage through the plant (Adams, 1969; March, 1975; Schubel, 1975; Ulanowicz, 1975). At the cold water intake, entrained organisms will be exposed to these conditions, plus a temperature change of approximately 20°C and a pressure change of nearly 100 atmospheres, all within a few minutes. The organisms entrained by an open-cycle OTEC plant are exposed to rapid decreases in pressure which occur in the flash evaporation chamber. Organisms entrained by an open-cycle plant, or at the cold water intake of a closed-cycle plant, will probably suffer 100% mortality. If any organisms survive to the discharge, they will be exposed to increased turbidity, light levels, and predation.

TABLE 3-2
ESTIMATED BIOMASS (WET WEIGHT) IMPINGED DAILY
BY VARIOUS SIZES AND NUMBERS OF OTEC PLANTS

		Micronekton Biomass Impinged (kg)	Gelatinous Organism Biomass Impinged (kg)
40-MW	Warm Water Screen	130	8.3
	Cold Water Screen	82	6.7
	Total	212	15
400-MW (1 plant)	Warm Water Screens	1,300	84
	Cold Water Screens	790	64
	Total	2,090	148
Cluster (8 plants)	Warm Water Screens	10,400	672
	Cold Water Screens	6,300	512
	Total	16,700	1,184
Park (146 plants)	Warm Water Screens	190,000	12,250
	Cold Water Screens	120,000	9,000
	Total	310,000	21,250

The daily entrainment rate of phytoplankton, microzooplankton, and macrozooplankton for various sizes and numbers of plants is given in Table 3-3. These estimates are based on using biomass averages presented in Chapter 2.

Entrainment at the cold water intake will be relatively low, primarily affecting macrozooplankton. The phytoplankton and microzooplankton biomass at 1,000 m depth is expected to be zero (Wilde and Sandusky, 1977; Wilde, 1978; Beers, 1978). Entrainment at the warm water intake is high, affecting phytoplankton, microzooplankton, and macrozooplankton. Phytoplankton and microzooplankton entrainment is not expected to seriously affect the populations, since the majority of the biomass is concentrated below the depth of the warm water intake. Entrainment of macrozooplankton by a 400-MW OTEC plant is high, almost $900 \text{ kg C day}^{-1}$, but is expected to have only a localized affect. However, multiple 400-MW OTEC plants may seriously disrupt the population. An OTEC park would entrain almost 130,000 kg C each day, which is comparable to 3% of the macrozooplankton in the upper 1,000 m of the eastern Gulf of Mexico OTEC resource zone each day. The effects of a disturbance of such magnitude in an oceanic environment cannot presently be predicted, but are expected to be significant. For instance, assuming a 10% transfer efficiency between trophic levels (Parsons and Takahashi, 1973), approximately 1,300 kg C or 3% of the potential nekton productivity in the eastern Gulf of Mexico OTEC resource area will be lost.

Perhaps the most critical biological implication of OTEC plants is the operation in proximity to shore and the effect of entrainment on the larvae of nearshore organisms. Around islands, the maintenance of a larval population near the spawning site is vital to adult population existence. Estimates of meroplankton (planktonic eggs and larvae of nearshore invertebrates and fish) abundance are extremely speculative, because larval abundance varies greatly according to species dominance, seasonal spawning patterns, and various other factors. For an order-of-magnitude estimate of effects, it is necessary to make three general assumptions: (1) meroplankton are attracted to structures and to lights, (2) one half of the zooplankton biomass is composed of meroplankton, and (3) the nearshore biomass within 2.5 km of shore is equal to ten times the biomass of the outer 2.5 km, assuming that all meroplankton are

TABLE 3-3
ESTIMATED BIOMASS ENTRAINED DAILY BY VARIOUS SIZES AND NUMBER OF OTEC PLANTS

Size of Operation	Intake	Phytoplankton Biomass Entrained (kg C)	Microzooplankton Biomass Entrained (kg C)	Macrozooplankton Biomass Entrained (kg C)
40-MW	Warm Water Intake	120	2.3	2.5
	Cold Water Intake	0	0	5.4
	Total	120	2.3	86.4
400-MW (1 Plant)	Warm Water Intake	1,200	24	830
	Cold Water Intake	0	0	50
	Total	1,200	24	880
Cluster (8 Plants)	Warm Water Intake	9,600	190	6,640
	Cold Water Intake	0	0	400
	Total	9,600	190	7,040
Park (146 Plants)	Warm Water Intake	175,000	3,500	121,000
	Cold Water Intake	0	0	7,300
	Total	175,000	3,500	128,300

within 5 km of shore (DOE, 1979c; Hirota, 1979). Thus, a 400-MW plant would entrain each day approximately 0.05% and 0.2% of the total meroplankton biomass around the Hawaiian Islands and Puerto Rico, respectively. This magnitude of loss may affect the total nearshore populations around the islands. Several large OTEC plants would impact the nearshore populations, including those of commercially important species, in localized areas.

3.3.4 Discharge

3.3.4.1 Ocean Water Mixing - OTEC plants will displace large quantities of ocean water, and cause disturbances of natural thermal structures, salinity gradients, and levels of dissolved gases, nutrients, carbonates, and turbidity, among others. Open-cycle OTEC plants will discharge waters with lowered dissolved oxygen concentrations. The magnitude of these effects vary from the operation of one plant to those of an OTEC park, and potentially result in adverse effects on local or regional marine ecosystems. An estimate of the downstream behavior of water discharged from an OTEC plant is essential for assessing the effects of these disturbances. An estimate of the plume behavior of moored and land-based OTEC plants is presented below. OTEC plant-ships can move with or against ambient currents, thus predictions of plume behavior of these plants are extremely difficult and will not be made.

(a) Plume Behavior - Discussions of downstream behavior of discharge plumes must include near- and far-field effects. The near-field is the region of the discharge plume dominated by the plant discharge geometry and its initial momentum (50 to 200 m from the plant). The near-field plume behavior predicted here is for the no current condition. Far-field processes refer to that portion of the discharge dominated by natural mixing processes (greater than 200 m from the plant).

Distinct but important processes occur in both regions. In the near-field, rapid initial mixing takes place. The choice of discharge port size, angle, and number of discharge ports governs the rate of initial mixing, which in turn determines the dilution and, together with the discharge depth the location of the discharge field within the water column. Mixing continues in the far-field but at much slower rates, since the mixing processes are

governed by small-scale turbulent eddies and vertical and horizontal current gradients. The discharge field is subject to advection away from the plant by ambient currents. Since low flows magnify impacts, a net current velocity of 12 cm sec^{-1} was used for plume calculations as a conservative estimate.

Modified versions of the near-field model of Koh and Fan (1970) and the far-field model of Brooks (1960) were used to investigate the geometry and dilution of a variety of OTEC designs. Mixing due to gravity spreading in the intermediate field, as defined by Jirka et al. (1979), is not included in Brook's far-field model. The Brooks model considers horizontal, but not vertical, mixing due to turbulent diffusion. The OTEC designs considered include: (1) a 400-MW plant composed of eight 50-MW power modules, each with a separate warm- and cold-water discharge directed vertically downward, (2) a 400-MW plant composed of eight 50-MW power modules, each with a mixed discharge directed horizontally, and (3) a 40-MW plant discharging a mixed effluent horizontally. The model predictions for the 40-MW plant represent both the open- and closed-cycle designs, since the flow rates differ by only about 10% and ignores the density modification that might occur in an open-cycle discharge due to flash evaporation. Results of model estimates are presented in Table 3-4. Details of the model and the input parameters are presented in Appendix C.

In the horizontal discharges that were examined the plume initially entrains the less dense waters near the surface and stabilizes high in the water column. The plume from the vertical discharge stabilizes deeper, due to the initial downward momentum and the entrainment of denser waters. The actual depth at which the plume stabilizes depends on the depth of the discharge port as well as the angle of discharge, the density of the effluent, and the ambient density profile. The effects of the ambient ocean current on the near-field plume behavior have been neglected in the calculation. Generally, the ambient currents tend to bend the plume trajectory in the direction of the current with the result that downward penetration may be decreased and dilution increased over the no-current case. Discharge configurations and ambient ocean conditions that result in the injection of the nutrient-rich cold water below the thermocline and photic zone have the potential of reducing recirculation to the plant intakes and increased productivity.

TABLE 3-4

DISCHARGE WATER PLUME MODELING RESULTS

Plant size		Near-field Results at Stabilization Depth						
		Vertical Travel (m)	Horizontal Travel (m)	Width (m)	Dilution			
40-MW		58	194	79	2.9			
400-MW, Separate Discharge		Warm 94	224	100	3.0			
		Cold 290	0	71	2.6			
400-MW, Mixed Discharge		85	203	84	2.0			
Farfield Results								
Downstream Distance (km)	40-MW		400-MW, Separate				400-MW, Mixed	
			Warm		Cold			
	Total Centerline Dilution	Width (m)	Total Centerline Dilution	Width (m)	Total Centerline Dilution	Width (m)	Total Centerline Dilution	Width (m)
10	34	1,300	3.0	650	7.3	595	2.0	620
20	86	3,300	3.2	750	15	1,200	2.2	730
30	151	5,800	3.5	860	24	1,930	2.5	840
40	228	8,700	3.8	970	34	2,800	2.8	970
50	314	12,000	4.3	1,080	41	3,700	3.1	1,100
60	410	16,000	4.7	1,200	58	4,700	3.5	1,200
70	513	20,000	5.2	1,320	72	5,800	3.9	1,400
80	623	24,000	5.7	1,450	86	7,000	4.3	1,500
90	741	28,000	6.2	1,580	101	8,200	4.7	1,600
100	866	33,000	6.7	1,710	118	9,500	5.1	1,800

The results from the near- and far-field models provide only gross estimates of plume behavior. Recent physical model studies by Adams et al. (1979 for OTEC plants in the 200-600 MWe range indicated that, in no-current cases, near-field plume centerline dilutions are on the order of 7 and that plumes stabilize near the thermocline. Therefore, as a first approximation, it will be assumed that the mixed discharge from 40- and 400-MW OTEC plants will remain above the thermocline and reach a thickness of approximately 60 m. Cold water plumes from OTEC plants with separate discharges and the plumes from plants releasing mixed discharges below the thermocline will probably sink to depths below the photic zone (125 m). Open-cycle plants may discharge waters of high salinity due to fresh water production, causing the plume to sink deeper. Subsequent observations and model predictions will assess the validity of these approximations.

The far-field mixing computation for a 400-MW OTEC plant results in low downstream dilutions. The total centerline (near- and far-field) dilutions 100 km (ten days travel at 12 cm sec^{-1}) downstream of 40- and 400-MW OTEC plants are approximately 900 and 5, respectively. Since the combined flow from the 146 OTEC plants composing an OTEC park ($0.4 \times 10^6 \text{ m}^3 \text{ sec}^{-1}$) is comparable to 0.5% of the Gulf Stream flow ($82 \times 10^6 \text{ m}^3 \text{ sec}^{-1}$; Stommel, 1960), an OTEC park may form a identifiable small-scale "artificial water mass" far downstream of the park. This "artificial water mass" could potentially affect the heat budget, climate, and biota of a region. The first several clusters may degrade the thermal resource for the downstream OTEC plants, if the mixed layer is reduced in thickness by injection of cool water above the thermocline. These effects would be mitigated if the plume remains below the mixed layer depth.

(b) Nutrient Redistribution - The transport of large volumes of deep water to the surface is comparable in many ways to the natural phenomenon of upwelling off the west coasts of the continents, Loop Current eddies in the Gulf of Mexico, and the intrusion of Gulf Stream water on the Continental Shelf off the southeastern United States coast. Experimental upwelling systems have provided primary production for aquaculture in the Virgin Islands and off California. All these processes, like OTEC, involve a parcel of nutrient-rich deep water which mixes with and diluted by nutrient-depleted surface layer

Primary production in oceanic and neritic waters is limited by the availability of usable nitrogen compounds (Ryther and Dunstan, 1971; Thomas, 1970). Nitrogen is usually available in regenerated form as ammonium nitrogen or as "new" nitrate-nitrogen from deep waters (Dugdale and Goering, 1967). OTEC power plants will discharge nutrient-rich deep water and nutrient-poor surface water into the surface layers of the ocean. In the deep ocean water the nitrogen:phosphorus ratio is close to that of Redfield's (1963) phytoplankton uptake ratio of 16:1. If the discharged waters remain above the 10% light penetration depth where light becomes a limiting factor (MacIsaac and Dugdale, 1972), enhanced primary production will occur. However, many simplifying assumptions must be made before the effects of this production can be assessed, and the following limitations in the data accepted:

- The seawater intake and discharge flow for large OTEC plants are estimates,
- The degree of expected mixing, nutrient characteristics of the discharged water, and depth of plume stabilization are estimates,
- Limited field studies on the initial and sustained nutrient (nitrogen) uptake rates of phytoplankton in oligotrophic, oceanic regions are available.

Incorporating these data limitations, the average phytoplankton standing stock was estimated at $0.1 \text{ mg chlorophyll } \underline{a} \text{ m}^{-3}$, which can be converted to biomass carbon by multiplying by 100 (Steele, 1964). The average growth rates of phytoplankton in nutrient-enriched oceanic waters was assumed to have minimum and maximum values of 1 and 2 doublings per day, respectively (Parsons and Takahashi, 1973). The maximum production value would occur under optimal conditions, whereas the minimum production value takes into account reduced production due to plume stabilization at a light-limiting depth, zooplankton feeding, and other production-limiting factors. A one-meter-long portion of the plume extending from the surface to 60 m depth was followed downstream as the plume widened due to entrainment of diluting water. The amount of nutrients dissolved in this portion of the plume was estimated at various

feeding, and other production-limiting factors. A one-meter-long portion of the plume extending from the surface to 60 m depth was followed downstream as the plume widened due to entrainment of diluting water. The amount of nutrients dissolved in this portion of the plume was estimated at various downstream distances as phytoplankton uptake decreased the nutrient concentration, and increased the phytoplankton biomass. The results of the calculations are listed in Table 3-5.

Chlorine concentrations below detectable limits inhibit phytoplankton growth (Carpenter et al., 1974; Eppley et al., 1976). Omitting the chlorine effects on phytoplankton growth, the nutrients released from a 40-MW OTEC plant will increase the phytoplankton biomass in the plume approximately three-fold after 20 km (two days) travel. In contrast, the phytoplankton biomass in the plume of a 400-MW OTEC plant will be approximately thirty times the ambient biomass concentration after 30 to 60 km (three to six days) travel downstream. Therefore, if the mixed discharges from large OTEC plants remain above the light compensation depth, an area with increased phytoplankton concentrations could be maintained downstream of the plants.

Red tide refers to the discolored patches of seawater accompanied by fish kills. The exact causes of red tide are not known, but an abundant nutrient source is required to sustain a bloom. The red discoloration is caused by an aggregation of dinoflagellates which produce a neurotoxin known to be lethal (Lackey and Hines, 1955), and has been reported in the nearshore waters of the eastern Gulf of Mexico. The redistribution of nutrient-rich waters into the surface layers by an OTEC park could cause or sustain a red tide outbreak, particularly if an OTEC plume containing increased phytoplankton biomass concentrations inoculates waters discharged from another OTEC plant. However, only certain species of dinoflagellates cause red tides, and the species are probably beneficial to the marine ecosystem except in extremely high concentrations. Elevated silicate concentrations in discharged waters will favor diatoms (which require silicate for their frustules) over dinoflagellates and coccolithophores (which do not require it). The increase of phytoplankton concentration downstream of OTEC plants could cause increased numbers of organisms in the higher trophic levels. Insufficient information is available on the dynamics of the marine food web to further evaluate this possibility.

TABLE 3-5
ENHANCED PRIMARY PRODUCTION DUE TO THE MIXED DISCHARGE OF NUTRIENT-ENRICHED
WATER IN A ONE-METER-LONG AND 60-METER-DEEP PORTION PLUME

40-MW OTEC Plant										
Downstream Distance (km)	Dilution	Volume (m ³)	1 Doubling Day ⁻¹				2 Doublings Day ⁻¹			
			Biomass (mg C m ⁻³)	Biomass Produced (mg C)	Nitrate Required (ug-atoms)	Nitrate Remaining (ug-atoms)	Biomass (mg C m ⁻³)	Biomass Produced (mg C)	Nitrate Required (ug-atoms)	Nitrate Remaining (ug-atoms)
0	0	2,240	10.0	0	0	33,600	10.0	0	0	33,600
5	15.0	36,000	NA	NA	NA	NA	20.0	360,000	4,500	29,100
10	34.3	79,000	20.0	790,000	9,900	23,700	29.1	1,150,000	14,465	14,635
15	58.1	132,450	NA	NA	NA	NA	36.1	1,163,500	14,635	0
20	85.9	195,000	23.7	1,884,000	23,700	0				

400-MW OTEC Plant										
Downstream Distance (km)	Dilution	Volume (m ³)	1 Doubling Day ⁻¹				2 Doublings Day ⁻¹			
			Biomass (mg C m ⁻³)	Biomass Produced (mg C)	Nitrate Required (ug-atoms)	Nitrate Remaining (ug-atoms)	Biomass (mg C m ⁻³)	Biomass Produced (mg C)	Nitrate Required (ug-atoms)	Nitrate Remaining (ug-atoms)
0	0	22,150	10.0	0	0	332,250	10	0	0	332,250
5	2.0	66,450	NA	NA	NA	NA	20	664,500	8,360	323,890
10	2.0	66,900	20.0	669,000	8,415	323,835	39.9	1,333,500	16,775	307,115
15	2.1	68,200	NA	NA	NA	NA	78.6	2,680,000	33,710	273,405
20	2.2	70,500	39.0	1,374,000	17,285	306,550	152.7	5,383,000	67,710	205,695
25	2.3	73,500	NA	NA	NA	NA	293.8	10,796,000	135,795	69,900
30	2.5	76,650	73.3	2,807,500	35,340	271,210	354.6	5,557,050	69,900	0
40	2.8	83,750	135.9	5,690,000	71,570	199,640				
50	3.1	91,000	251.7	11,452,500	144,060	55,580				
60	3.5	99,700	274.9	4,418,600	55,580	0				

c) Carbonate Equilibrium - Given the range of conditions under which an OTEC plant will operate (temperature: 5° C to 30°C; pressure: 1 to 100 atm; salinity: 34 to 38 ppt; pH: 7.6 to 8.3; and Eh: generally oxidizing) and the ionic composition of seawater, only the carbonates, calcite and aragonite, are near or above saturation (Wilde 1977). Calcite is less soluble than aragonite, thus in the Atlantic and Pacific Oceans the water remains super-saturated with respect to calcite to much greater depths than aragonite. One reaction of concern for OTEC is the replacement of phosphate ions by carbonate ions in preexisting calcium carbonate scale, which produces calcium phosphatic scale. Such a reaction is highly probable when raising phosphate-rich seawater from depth, since this reaction occurs naturally in the formation of phosphatic nodules in natural upwelling areas (Ames, 1959).

Potential problems from thermal mixing are precipitation of aragonite and calcite from the deep ocean waters. By raising waters saturated with calcium carbonate, carbon dioxide may be removed by warming, and inorganic precipitates (aragonite and calcite) may form. Deposition of these precipitates on the surface of an OTEC heat exchanger may form a film or scale. A layer of film exceeding a thickness of 5 micrometers could decrease the heat transfer properties of the heat exchanger beyond acceptable limits (Morse et al., 1978).

The formation of mineralogic films is governed by physical electro-chemical processes, most significant of which are saturation, replacement, and nucleation (Wilde, 1977). The ability of heat exchanger surfaces to act as nucleation sites for the deposition of carbonate is strongly dependent on the chemistry of the heat exchanger surfaces during corrosion. Only general information is available on the calcium carbonate equilibrium in the OTEC resource area, and no accurate prediction model exists to estimate the scale formation on heat exchangers due to OTEC operation. Studies at the preoperational platform will provide further information on carbonate equilibrium.

(d) Deaeration of Ocean Water - Non-condensable gases have adverse effects on heat transfer processes in the condensing heat exchanger of the open-cycle system. Noncondensable gases must be removed to maintain the heat transfer effectiveness in condensing the steam.

Release of deaerated water could cause environmental consequences. Dissolved oxygen concentration in the mixed discharge of a 40-MW open-cycle OTEC plant is approximately 1.8 ml liter⁻¹; however at 200 m downstream of the plant, the entrainment of ambient waters is expected to increase the dissolved oxygen concentration at the centerline of the plume to 80% of ambient, or about 4.2 ml liter⁻¹. This replenishment of dissolved oxygen in the near-field indicates that no adverse effects are expected.

3.3.4.2 Chlorine Release - Chlorine used to prevent biofouling on the seawater side of the heat exchanger surfaces of closed-cycle OTEC plants may be irritating or toxic to marine organisms. Chlorine, in conjunction with one of the potential working fluids, ammonia, may have synergistic effects. In order to assess the impact of discharging chlorinated effluents, it is necessary to obtain information on chlorine reactions in seawater, decay rate, toxicity, and expected release rate.

(a) Reactions in Seawater - It is not possible to confidently predict the chemical species generated by chlorinating natural seawater (Block et al., 1977). Information necessary but not available includes data concerning: (1) trace catalysts in seawater which control or influence chlorine reaction paths, (2) importance of photochemical mechanisms, and (3) components of seawater which contribute to chlorine demand (Block et al., 1977). A theoretical model summarizing the suspected pathways of inorganic chlorine chemical reactions in seawater is shown in Figure 3-1. In general, chlorine reacts with seawater to produce hypochlorous acid or hypochloride. Under normal conditions the hypochlorous acid will dissociate, and react with naturally-occurring bromide ions to produce hypobromous acid. Ultimately, the hypobromous acid will appear as bromate (DOE, 1979d). In sunlight, the reactions occur rapidly and 50% of the chlorine added to the seawater produces bromate. The principal expected inorganic compounds of concern are hypobromous acid, hypobromide ion, and possibly tribromomine (DOE, 1979d).

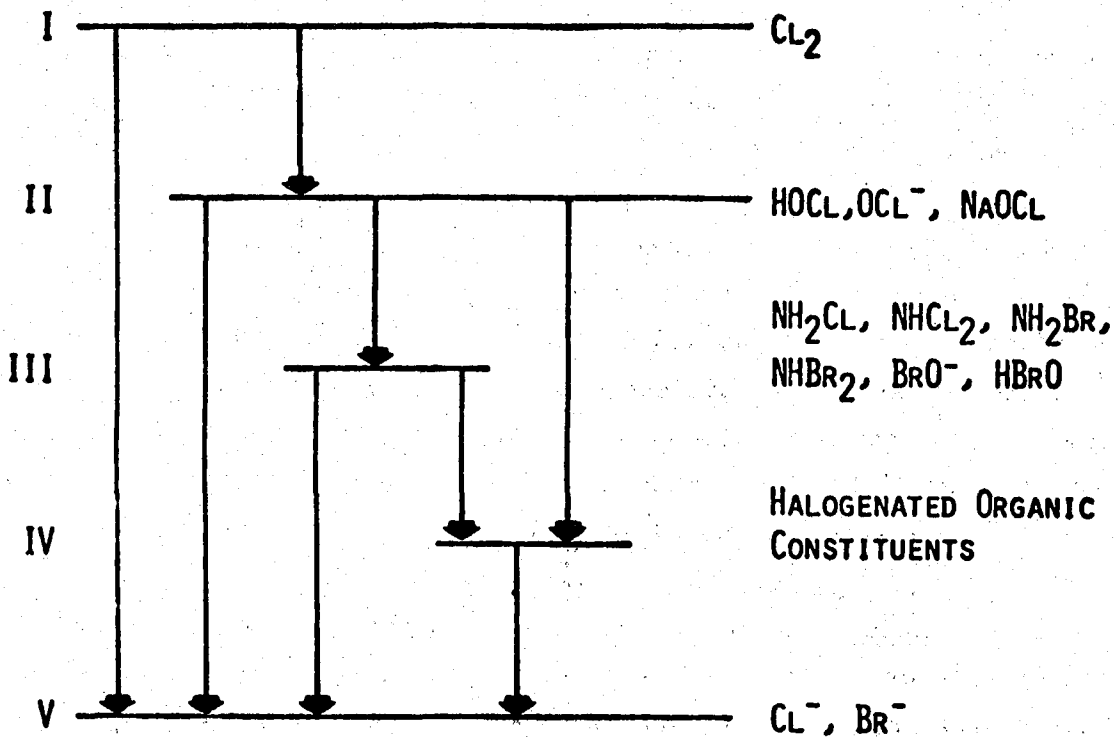

Figure 3-1. Degradation Processes for Chlorine in Saline Waters
Source: Block and Helz, 1975

Inorganic reactions of chlorine are predictable, but organic reactions are not. Preliminary evidence indicates that new compounds formed may be more toxic than the inorganic forms. The principal organic compounds are bromomines, bromoforms, and trihalomethanes; however many compounds remain unidentified (DOE, 1979d).

(b) Decay Rate - Macalady et al. (1977) studied the disappearance of residual oxidants (chlorine, hypochlorous acid, hypochlorite ion, inorganic and organic chloramines, and other compounds) in chlorinated seawater exposed to sunlight. Samples exposed to full midday sunlight underwent 80% degradation in less than 1 hour and 95% degradation after 2 hours. When subjected to overcast conditions (less than 20% full sunlight) samples underwent 80% degradation after 2 hours; after 3 hours, greater than 15% of the initial chlorine dosage remained (Figure 3-2).

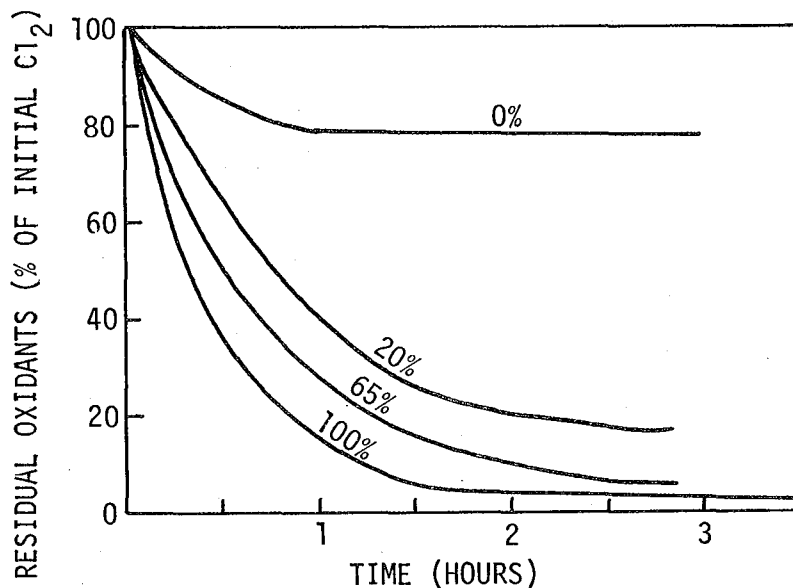

Figure 3-2. Disappearance with Time of Residual Oxidants in Chlorinated Seawater as a Function of Exposure to Sunlight (in percent).
Source: Macalady et al., 1977

(c) Toxicity Data - A review of the toxicity of chlorine reaction products to organisms in the OTEC resource area was compiled by an OTEC preoperational platform environmental assessment the (DOE 1979c). This review indicated that phytoplankton are the organisms most sensitive to chlorine. Several investigators (Carpenter et al., 1974; Eppley et al., 1975) reported severe and irreversible (50% to 83%) decreases in phytoplankton photosynthesis at chlorine concentrations which were below the analytical detection limit (less than 0.1 mg liter⁻¹). No toxicity data is available for organisms which commonly inhabit tropical-subtropical oceanic environments (DOE, 1979c). Studies are presently underway at the Gulf Coast Research Laboratories (GCRL) to examine chlorine toxicity in oceanic zooplankton and fish.

(d) Release Rate - Discharge of chlorinated cooling waters for more than two hours in any one day is restricted (EPA, 1976b). The allowable discharge concentration for these two hours must average $0.2 \text{ mg liter}^{-1}$ over 30 days, with a maximum of $0.5 \text{ mg liter}^{-1}$. Therefore, a maximum of 375 and 3,700 kg day^{-1} of chlorine could be discharged to the surface layers of the water column from closed-cycle 40- and 400-MW OTEC plants, respectively.

The centerline chlorine concentrations downstream of 40- and 400-MW OTEC plants are given in Table 3-6. The chlorine concentration in the plume from a 40-MW OTEC plant is reduced to $0.01 \text{ mg liter}^{-1}$ within 12 hours (5 km downstream), but a plume from a 400-MW plant has a maximum concentration of $0.03 \text{ mg liter}^{-1}$ after ten days (100 km) downstream travel. Therefore, the chlorine discharged from a 40-MW OTEC plant may affect organisms for up to 24 hours after discharge, whereas the plume from a 400-MW OTEC plant exposes marine organisms to low chlorine concentrations for much longer periods of time.

Residuals from a cluster of OTEC plants may not degrade before leaving the park area, thereby further increasing residual levels. The sublethal effects from long-term exposure to chlorine are not known, and represent a serious problem. An advantage of an open-cycle OTEC plant is the lesser requirement to use chlorine.

3.3.4.3 Working Fluid Leaks - The effect of working fluid leakage on marine organisms is a function of the type being used, the release rate, and the organisms in the vicinity of the plant. A small accidental release of ammonia may increase primary productivity downstream of the plant. A minor release of Freon™ may irritate sensitive organisms in a localized area around the plant. A catastrophic spill of either working fluid would result in a total release to the receiving waters and adversely affect the environment. The normal operating inventory of ammonia for a 400-MW OTEC plant is estimated at $10,000 \text{ m}^3$ ($7.2 \times 10^{12} \text{ mg}$), thus the EPA water quality standard would not be exceeded

TABLE 3-6
 CENTERLINE DILUTION AND CHLORINE CONCENTRATION DOWNSTREAM
 OF A CLOSED-CYCLE 40- AND 400-MW OTEC PLANT

Downstream Distance (km)	40-MW		400-MW	
	Total Dilution	Chlorine Conc. (mg liter ⁻¹)	Total Dilution	Chlorine Conc. (mg liter ⁻¹)
0	0	0.20	0	0.20
0.2	2.9	0.05	2.0	0.07
0.5	3.2	0.05	2.0	0.07
1.0	4.1	0.04	2.0	0.07
1.5	5.2	0.03	2.0	0.07
2.5	7.6	0.02	2.0	0.07
5	15.0	0.01	2.0	0.07
10	34.3	<0.01	2.0	0.07
20	85.9	<0.01	2.2	0.06
40	227.9	<0.01	2.8	0.05
60	409.5	<0.01	3.5	0.04
80	623.5	<0.01	4.3	0.04
100	865.5	<0.01	5.1	0.03

unless the plant was losing 0.3% of its total ammonia inventory each day (DOE, 1977a; EPA, 1976). Such a serious malfunction could result from a major breakdown, a collision with a vessel, or damage from a tropical storm. Additional information on the chemistry of Freon™ in seawater and the toxicity of ammonia and Freon™ to organisms common to the OTEC resource area is necessary before further assessment of working fluid leaks can be made.

In each closed-cycle OTEC plant, large heat exchanger surface areas will be exposed to constant physical and chemical stress. Thus, leaks may develop in the working fluid transport system. Once released into the environment, the fluids may affect exposed organisms.

Large volumes of ammonia or Freon™ will be stored on OTEC platforms and may be released into the environment by slow or fast leaks. Ammonia is soluble in seawater and forms ammonium hydroxide, which dissociates into ammonium and hydroxyl ions and increases the pH value. During a large ammonia surface spill, 40% would be released into the atmosphere and the remaining 60% would dissolve (EPA, 1977). No information is available on the chemistry of Freon™ in seawater, but Freon™ (fluorotrichloromethane) has a boiling point of 23.7°C (Verschueren, 1977) and a high percentage of a surface spill would be released into the atmosphere, with a smaller percentage dissolved in seawater.

In a review of ammonia toxicity data for marine organisms, it was determined that the only ammonia bioassay information applicable to OTEC resource organisms is from Natarajan (1970). Concentrations of 55 to 71.1 mg liter⁻¹ of ammonia was found to inhibit photosynthesis in unspecified marine phytoplankton. Toxicity studies by the Gulf Coast Research Laboratory are underway to examine effects of ammonia in zooplankton and fish. No information is available on the toxicity of Freon™ in marine organisms.

3.3.4.4 Trace Constituent Releases - Trace constituent releases from OTEC plants will occur from the seawater corrosion and erosion of structural elements within the plant (heat exchangers, pump impellers, metallic piping) and the process wastewater pollutants generated by production of aluminum and/or ammonia. The discharge or release of trace constituents from these

sources could prove to be toxic or sublethal to many marine organisms and possibly be transferred up the marine food chain to be bioaccumulated by organisms in the higher trophic levels.

(a) Structural Releases - The major source of trace constituent release is from the heat exchangers. The condenser and evaporation heat exchangers will be constructed of aluminum, titanium, or stainless steel. The pump impellers and metallic piping are comparatively minor sources; however, they include copper-bearing alloys and lead-bearing materials which have high toxic potentials.

A review of the limited data on aluminum and titanium toxicity indicates that toxicity of these metals is very low (DOE, 1979c). Information is limited relative to the toxicity of copper in marine invertebrates or fish indigenous to tropical-subtropical oceanic regions (EPA, 1976a). Saifullah (1978) found copper to inhibit three species of marine dinoflagellates at concentrations above 1,000 mg liter⁻¹, although exposure to 20 mg liter⁻¹ for more than twenty hours decreased growth rates.

Design projections estimate that approximately 9.3 m² of exchanger surface area are required for each kilowatt capacity in an OTEC plant (DOE, 1978). Therefore, a 400-MW plant would need an area of over 3.7 million m², all subject continuously to the erosive and corrosive actions of seawater. To obtain a trace metal concentration of 1 mg liter⁻¹ at the point of discharge, approximately 60 g m⁻² of heat exchanger surface would have to be lost each day (Appendix C). The trace element release is expected to be several orders of magnitude less than this, thus concentrations of trace metals will be extremely low and no impact is expected. However, a cluster or park of OTEC plants may increase the trace metal concentration over vast ocean areas and bioaccumulation of metals may result, either through absorption or ingestion.

(b) Process Waste Water Releases - Ammonia and aluminum processing facilities will release point source discharges of process wastewaters into the oceanic environment. Impacts of releases on oceanic organisms cannot be assessed, since information is lacking on the quantity and character of the discharge, as previously described.

In licensing of OTEC industrial plants, the Environmental Protection Agency (NPDES permit) will establish limiting permissible concentrations for process wastewater discharges into oceanic water by having bioassay or bioaccumulation studies conducted on appropriately sensitive marine organisms. Routine studies will be required to satisfy NPDES permit requirements. OTEC plants will comply with all regulations, therefore process wastewater releases should not significantly affect oceanic populations.

3.3.4.5 Detrital Releases - OTEC operation will result in the destruction of marine organisms, primarily due to impingement and entrainment. The phytoplankton biomass, which initially increased due to nutrient redistribution, may die and decay after the nutrients are utilized. Most of the biomass will either decay, sink to the bottom and increase the benthic biomass downstream of the plant, or be ingested by other organisms attracted to the area. Each milligram of decaying carbon biomass utilizes 2.45 ml of oxygen (Redfield et al., 1963). Using this ratio, the approximate reduction of dissolved oxygen due to biomass degradation can be estimated.

Impinged and entrained biomass and the increased phytoplankton biomass from the release of nutrient-rich water are listed in Table 3-7. The dissolved oxygen required to degrade this biomass is also included. The impinged biomass estimate was obtained by assuming that carbon biomass is 9% of wet weight biomass (Omori, 1974). Rate degradation information is unavailable for time estimates of biomass oxidation, however, oceanic bacterial action is extremely slow. In contrast, if all the biomass impinged, entrained, or produced by the operation of an OTEC park were confined to the upper 1,000 m of the eastern Gulf of Mexico OTEC resource zone, less than 0.1% of the oxygen would be lost. This is a negligible amount; consequently, significant effects are not expected.

3.4 ECONOMIC ISSUES

3.4.1 Baseload Electricity

Baseload electricity production in the Gulf Coast States relies primarily on oil, natural gas, and coal. In compliance with the National Energy Act

TABLE 3-7
 OXYGEN UTILIZATION DUE TO BIOMASS DEGRADATION

Size of Operation	Impinged		Entrained		Produced	
	Biomass (mg C)	Oxygen Required (ml)	Biomass (mg C)	Oxygen Required (ml)	Biomass (mg C)	Oxygen Required (ml)
40-MW	0.02×10^9	0.05×10^9	0.2×10^9	0.5×10^9	0.003×10^9	0.007×10^9
400-MW	0.2×10^9	0.5×10^9	2.1×10^9	5.1×10^9	0.026×10^9	0.064×10^9
Cluster	1.6×10^9	4.0×10^9	16.8×10^9	41.2×10^9	0.2×10^9	0.5×10^9
Park	29.8×10^9	73.0×10^9	306.8×10^9	751.7×10^9	3.8×10^9	9.3×10^9

(1979) utilities are converting to coal and natural gas in order to reduce oil dependency. Other energy options under investigation in the Gulf Coast include nuclear and hydroelectric power production. Power produced by OTEC platforms in the Gulf of Mexico would decrease coal consumption, but would not be cost-competitive for several years, due to high transmission costs. Electrical transmission beyond fifty-four kilometers will require a d.c. converter, which nearly doubles transmission costs. For example, at 150 km, the converter cost equals the cable costs. Multiple cables will be necessary, as the maximum load per cable is estimated at 500- TO 1,000-MW (Traut, 1979). Transmission distance off Tampa is approximately 260 km; estimated transmission costs are \$0.5 million per km/500-MW.

Island communities are almost totally dependent on foreign imported oil, with few viable alternatives available; islands are increasingly vulnerable to oil price increases and future oil embargoes. Future economic development will be tied to oil prices. The prospect of OTEC energy production will create long-term price stability for economic development and total energy independence, and be a positive influence on the economy.

By 1995, collective populations of Hawaii, Puerto Rico, and Guam are projected to be nearly six million people. Hawaii's population is distributed among six islands, with over 75% on the island of Oahu. By 1995, approximately three to five 400-MW OTEC plants will be required to supply 100% of the required power, with the majority of plants off Oahu. The electrical transmission grid is not uniformly developed in Hawaii, and several undeveloped coastal areas are without power. OTEC development would entail grid development compatible with the locations of thermal resources.

Puerto Rico's population is nearly four times that of Hawaii and the island has an extensive electrical transmission grid, thus allowing easier incorporation of OTEC. By 1995, approximately fifteen to twenty 400-MW OTEC plants will satisfy 106% of Puerto Rico's demand. Guam will require only one 400-MW plant by 1995.

3.4.2 Plant-Ship Products

Ammonia is the most likely OTEC plant-ship product (General Electric, 1977). Plant-ship production has the principal advantage of freeing large quantities of natural gas (presently used for ammonia production) for other uses. Plant-ships would rely on nitrogen from the atmosphere and hydrogen from the water for raw materials. The production of ammonia has been demonstrated to be cost-effective against land-based methods and would affect the industry positively (Francis, 1977; General Electric, 1977). Production of ammonia by plant-ships would reduce the U.S. dependence on foreign markets.

Aluminum was examined for potential OTEC plant-ship production. While ammonia plant-ships produce the product independently of land-based resources, aluminum plant-ships require bauxite or alumina supplies. The cost of transporting the materials and the final product (aluminum) increase overall production costs significantly. The possibility of producing aluminum in land-based plants adjacent to bauxite resources requires further attention (i.e., an OTEC plant off Dampierland, Australia).

3.5 OTEC ENVIRONMENTAL STUDIES

3.5.1 Status

The OTEC commercialization scenario presents several unique situations: (1) large-scale ocean use has not been practiced in tropical-subtropical areas, (2) most ocean activities have been associated with the coastal zone and not the open ocean, (3) the continuous redistribution of ocean properties has not been examined in the scales projected for OTEC induced processes in the open subtropical-tropical ocean, and (4) oceanic organisms have adapted to a highly stable environment and are not able to endure the same range of environmental limits as coastal organisms. The exposure of such organisms to trace element release, chlorine and its derivatives, and an altered temperature regime may upset the ecological balance.

OTEC environmental studies to date have included: (1) preparation of an Environmental Development Plan, (2) generation of physical predictive models,

(3) preparation of environmental assessments, (4) toxicity studies, and (5) ocean survey data collection. This progression, in concert with OTEC program timing, provides for thorough considerations of environmental issues in advance of the demonstration and commercialization actions.

The OTEC Environmental Development Plan (EDP) addresses health, safety, and environmental issues associated with development, demonstration and commercialization. The OTEC EDP was first published by DOE in March 1978, and updated in August 1979. The EDP provides a common basis for planning, managing, and reviewing all environmental aspects of the OTEC program. The EDP precedes key program decisions during transitions from development to demonstration to commercialization.

Physical models are important for projecting plume dilution and dispersion, and examining recirculation potentials from various discharge configurations. Near-field models have been developed; further efforts are underway for the intermediate zone. Whole basin studies have been continued by Dynalysis of Princeton. This large-scale model may be used to examine the physical effects in the Gulf of Mexico due to OTEC deployments. Data from the physical studies will provide guidance in many aspects of the OTEC program, including engineering designs and environmental studies. A summary of the physical studies program is given by Ditmars and Paddock (1979).

Environmental Assessments are required by the National Environmental Policy Act (NEPA) of 1969, and consider several key environmental issues prior to actual deployment or operation of the platforms. The preoperational platform (OTEC-1) EA was published in March 1979; the supplement to the EA (specific to final platform design and test site) was issued in April 1979 (DOE, 1979c; Sinay-Friedman, 1979).

Zooplankton and fish toxicity studies underway at Gulf Coast Research Laboratory (GCRL) using chlorine, ammonia, and titanium will provide valuable data on organism tolerance of such releases. The studies will continue for several years, and will include many different organisms and toxicants. Eventually, bioassays will be conducted in situ, to determine acute and chronic limits of OTEC releases.

Several oceanographic surveys have been conducted at candidate OTEC sites in the Gulf of Mexico, Puerto Rico, Hawaii, and the South Atlantic. The site studies will provide a baseline from which future studies can be based.

3.5.2 Future Requirements

A range of environmental studies must be conducted in the future. The required studies can be broadly categorized into: (1) baseline, (2) impact, and (3) monitoring studies (Green, 1978). A baseline study is performed to define or characterize the biological community, the environment, or both. The studies provide information on the natural variations over different locations and times. Impact studies are necessary to determine if a specific impact will cause a change in the biological community; if a change does occur, the impact study will assess the effects of that change. In an impact study, the nature and exact area of existence of the impact must be known. The objective of the monitoring study is to detect a change from the present state attributable to a specific action. A monitoring study requires baseline data which serve as the comparison point. Degrees of change may be distinct or barely detectable. Generally, monitoring studies are most accurate when they are based upon results of previous impact studies (Green, 1978).

Thus, the main course for evaluation of impact extent and design modifications (to reduce or mitigate impact) is an impact study. There are four basic criteria for impact studies (Green, 1978):

- (1) The impact must not have occurred, thus implying that pre-impact data can be collected.
- (2) Previous studies must indicate the type of impact expected and the time and place of most likely occurrence.
- (3) The measurements for impact detection of the biological and environmental variables must be feasible and possible.
- (4) An area outside of the impact influence must exist to serve as a study control or reference.

Prerequisites (1) and (4) imply the need for a control or reference area for comparisons over time and space. Spatial controls provide a mechanism to positively indicate changes due to impact. Temporal controls provide data which indicate whether a system change occurred in the region before, during, or after the impact occurred. This is illustrated in the matrix of Figure 3-3. The timing of OTEC development must include time allowances to conduct optimal impact studies. The studies must take into account an area by time-grid approach. Appropriate baseline and monitoring programs are required to support the impact studies.

Questions			Main Sequence	Description
1. Has the impact already occurred?	2. Is where and when known?	3. Is there a control area?		
YES	NO		5	"WHEN & WHERE" IS THE QUESTION
	YES		4	IMPACT MUST BE INFERRED FROM SPATIAL PATTERN ALONE
NO	NO		3	BASELINE OR MONITORING STUDY
		NO	2	IMPACT MUST BE INFERRED FROM TEMPORAL CHANGE ALONE
	YES		1	PERMITS AN OPTIMAL IMPACT STUDY DESIGN
		YES		

Figure 3-3. The Decision Key to the "Main Sequence" Categories of Environmental Studies

Source: Modified from Green, 1978

Other OTEC Environmental programs required in forthcoming years include:

- Field:
1. Baseline studies to document both spatial and temporal variations prior to platform deployment and operation.
 2. Impact field studies for initial platforms.
 3. Monitoring studies.
 4. Flora and fauna terrestrial investigations.

- Lab:
1. Toxicity studies and chronic bioassays to determine the effects of OTEC-related releases.
 2. Chlorine research to determine which compounds are formed in seawater and in biota tissues.
 3. Intermediate-field and far-field dispersion model studies to examine plume behavior and discharge mechanism. The early platform measurements must be used to calibrate the on-line models.
 4. Large-scale whole-basin physical models that can eventually be expanded to ecologic models. These large-scale models can be used to evaluate the effects of different platform designs on the environment.

- Impact Assessments
1. Impact studies, first, to quantify the degree to which impacts occur, and secondly, to examine what platform design modifications may mitigate or reduce effects.
 2. Platform- and site-specific Environmental Impact Statements. Future OTEC platforms will be sufficiently large to warrant a thorough environmental review, with an EIS on a site-specific basis.
 3. Health Risk Assessment Models for all OTEC platforms.
 4. Complete health and safety management programs.
 5. Resolution of international issues.
 6. Resolution of OTEC Federal licensing proceedings.
 7. Generic environmental assessment of the open-cycle system.
 8. Large-scale climatic research.
 9. Safety Analysis Reports.

3.6 UNAVOIDABLE ADVERSE EFFECTS

Environmental impacts which are unavoidable consequences of OTEC development to commercial operation include:

- Biocide release
- Trace constituent releases
- Organism impingement and entrainment
- Redistribution of ocean properties
- Exposure to accidents

The magnitude of these effects can be minimized by proper ocean management practices.

3.6.1 Biocide Release

OTEC plants may use biocides to control biofouling on the seawater side of heat exchanger surfaces. Biocides may adversely affect the local marine environment because of their toxicity to nontarget organisms and the large volumes that must be released to maintain heat exchanger efficiency.

3.6.2 Trace Constituent Releases

Trace constituents will be released to the environment from protective hull coatings and power cycle components as a result of seawater corrosion and erosion. Chlorine, the projected biocide to control heat exchanger biofouling, will be released into the marine environment.

Several new compounds of unknown toxicity may be formed by the reaction of chlorine with seawater. The release of trace elements, chlorine, and chlorine reaction products may reduce biomass and present public health risks.

3.6.3 Organism Impingement and Entrainment

Organisms which inhabit waters surrounding OTEC plants will be subjected to impingement on the intake screens or entrainment through the power cycle.

Only those organisms which have insufficient avoidance capabilities will be subject to these effects. The quantity of biomass is a direct function of the volume of water pumped: a 400-MW plant will impinge or entrain approximately 10 times the biomass of a 40-MW plant. The mortality rate of impingement and entrainment may be nearly 100%.

3.6.4 Redistribution of Ocean Properties

Organisms will congregate around OTEC platforms, the intakes, and discharge ports, thereby altering community composition. The redistribution of nutrients (at concentrations above ambient) may increase biomass productivity downstream of the plant.

The elevation of water to the surface from 900 to 1,000 m depth with a higher solubility of carbon dioxide than surface waters will cause carbon dioxide releases. A 400-MW OTEC plant will release approximately one-fourth the carbon dioxide of a similarly sized fossil fuel plant. The extraction of heat from the ocean surface waters may, in combination with carbon dioxide release, affect the regional climate of the OTEC area in the case of large-scale deployments of many 400-MW plants.

As a consequence of fresh water production, the open-cycle OTEC plant may release ocean waters extremely low in dissolved gases, particularly dissolved oxygen which is the life-sustaining gas of the marine environment.

3.6.5 Exposure to Accidents

The occupation of OTEC platforms exposes the surrounding population and environment to the hazards of accidents. Island land-based or moored plants will likely be located near population centers, to which potentially hazardous vapors could be transmitted. Plant-ships will be several hundred kilometers from land, and will subject crews to operational hazards far from land facilities.

3.7 RELATIONSHIP BETWEEN SHORT-TERM USE AND LONG-TERM PRODUCTIVITY

The tropical oceanic environment is not used to any great extent for food production. The development of the thermal resource for power production would be the first resource exploitation of most tropical oceanic areas. The sites for OTEC development will be designated for power production and will not be located near commercial shipping lanes, proposed or existing oil or gas exploration areas, site-use conflict zones, or ecologically sensitive areas. Detailed site investigations will be performed in order to select optimal locations. Overall OTEC development requires strict ocean management to ensure that no adverse effects result. Deep ocean mining resources may occur in the general operating vicinity of OTEC plant-ships.

3.8 IRREVERSIBLE AND IRRETRIEVABLE RESOURCE COMMITMENT

The marine biota at the OTEC sites will be subjected to several alterations in the environment. The extent of impact or magnitude of change due to OTEC operations cannot be fully evaluated due to the lack of data on food chain dynamics, trace constituent toxicity, and chlorine-derived reaction product toxicity. Specific data is required on the environment where OTEC platforms will be sited and on the various platform designs. Significant resource commitments can be avoided or minimized provided that further investigations of key problem areas are performed early in technology development.

Several raw materials, consumables, and construction materials will be used throughout the development of OTEC platforms. The magnitudes of committed materials has not been projected.

Chapter 4

RISK OF CREDIBLE ACCIDENTS

Potential occurrences of credible accidents must be carefully and thoroughly reviewed prior to the deployment of a demonstration- or commercial-sized OTEC plant. Operations in the marine environment present several unique hazards or potentials for accidents. An OTEC plant-ship, with a large crew, may be located as far as 480 to 600 km offshore, thus limiting the amount of shore-based dependency. Moored and land-based plants may be adjacent to population centers, where vapors from operating fluid leaks could pose serious health threats. The positioning of an OTEC baseload-electrical-generating facility offshore may expose the plant to power outages resulting either from acts of nature or man-induced problems. Thus, the population affected by an OTEC plant includes: the platform crew, the adjacent population within range of effects, and the population center served by the plant.

Potential threats to health and safety for all three communities must be quantified for possible accidents, based upon the regional and the platform data. One way to assess the risk or potential for accident is by means of a Risk Assessment Model. This chapter presents an overview of elements to be considered in designing an OTEC Risk Assessment Model. Situations which require preparation of emergency contingency plans and measures to reduce or mitigate the risks of credible accidents are described.

4.1 CONSIDERATIONS FOR A RISK ASSESSMENT MODEL

An OTEC Risk Assessment Model should describe the probability of events which may jeopardize health or safety of the individuals affected by OTEC plants. No single model is available, or applicable, which considers all aspects of OTEC operations. At a minimum, the following data for platform

characteristics and operational site or regional characteristics must be compiled in order to accurately assess the risk potentials of OTEC plants:

Platform Characteristics:

- The operational and survival limitations of overall platform design and construction must be assessed. Several different designs and construction materials have been considered for OTEC plants. The operational and survival limitation of each component must be collectively examined for abilities to withstand the stresses imposed by the marine environment.
- The operation and maintenance hazards associated with each OTEC design must be assessed and rated. For example, one industrial process may be preferred over another, with loss of efficiency, if it significantly reduces accident potentials.
- The potential for a major spill of OTEC fluids must be assessed. Of particular concern is the toxicity of the constituents onboard and potential reaction products formed.
- The characteristics (e.g., boiling point, melting point) and volumes of fluids onboard must be evaluated with respect to accident potential. For example, it may be preferable to resupply the platform more frequently, rather than have large holding capacities.
- For plant-ships, accident records must be closely compared with similar land-based production facilities. This information must be incorporated for at-sea operations to maximize safety and minimize downtime.

Site Characteristics:

- The historical meteorological conditions of the region (including wind speed and direction, currents, wave height, air/water

temperature, and tropical cyclone or hurricane path, duration and strength) are critical to platform operation and survival. Frequencies of occurrence of operational and survival conditions for a site or region are important to design in both minimum and maximum operation limits. Meteorological data indicate prevailing wind speed/direction, which can be used to determine the time and direction of travel of vapors originating from a major leak.

- The origin, type, frequency, and cargo of ship traffic through the region are important, as is the servicing Port Safety Index (Schneider and Lambert, 1978).
- Evacuation times for removal of platform personnel and the adjacent shore-based population.
- The frequencies of fog or variable visibility days that may limit supply vessel loading and unloading.
- The hazardous spill clean-up crew response times.

These data must be assembled into a handbook for OTEC regions and a Risk Assessment Model developed. As a starting point, the U.S. Coast Guard has developed several methods for Marine Safety Risk Assessment which can be applied to OTEC evaluations (Schneider and Lambert, 1978). This Risk Assessment Model is a fundamental component of the DOE required SAR.

4.2 POTENTIAL EMERGENCY SITUATIONS

4.2.1 Man Made

- Collision: As described by Knight et al. (1977), the frequency of collisions at sea is significantly higher close to shore. Coastal traffic is primarily small craft, whereas major ship traffic is prevalent around harbor entrances and on the open ocean. Specific items to be considered in collisions include: detailed evacuation procedures, fluid flammability and communication procedures. OTEC

commercialization regions should be clearly marked on navigational charts and be internationally recognized. Ship traffic near OTEC platforms must be strictly controlled and monitored to avoid catastrophe.

- Accidents: Accidents of many types requiring fire fighting or other emergency operations will occur on OTEC platforms. A complete appraisal of accident potentials must be performed and probability indices assigned. The OTEC crew must be composed of experienced and skilled individuals. It is imperative that a detailed safety program be developed, which documents both the potential for accidents and the corrective steps if an accident occurs.
- Military/Political Terrorism: OTEC platforms, particularly those providing baseload electricity, will be susceptible to takeover by political dissenters of various persuasions. The potential for takeover will be influenced by the community served, the dependency upon OTEC platforms, and the degree of protection provided for the platforms.

4.2.2 Acts of Nature

During its operational lifetime, an OTEC platform will endure several hurricane- and sub-hurricane-force storms. As a matter of safety and practicality, it is expected that platforms will be designed to survive 100-year storms. OTEC platforms are not greatly motile, and will require several days to vacate an area; consequently site evacuation is not a reasonable consideration. Thus, it is imperative to design platform survival limits, with contingency plans around the worst possible situations. A contingency plan must be prepared to ensure the safety of the crew and to maintain platform integrity throughout irregular events.

4.3 MITIGATING MEASURES

4.3.1 Risk Assessment Studies

Risk assessment is a fundamentally critical aspect of OTEC demonstration and commercialization and a DOE requirement for the SAR. The occurrence of a credible accident can be adequately anticipated by means of a detailed Risk Assessment Model. Models should be specifically applicable to platform designs and siting locations. Risk assessment studies must be performed for the candidate regions early in the OTEC commercialization scheme.

4.3.2 OTEC Traffic

Traffic controls around OTEC facilities are required for coastal areas and for the open ocean. In coastal areas, OTEC platforms will attract curious onlookers and fishermen. To prevent such individuals from interfering with OTEC operations, and to protect them, approach boundaries must be established. A security buffer zone should extend beyond the region to prevent access by unauthorized individuals. Knight et al. (1977) suggest that the USCG border of 500 m be applied. The safe-approach radius around the platforms will depend upon the area of activity associated with platform movements, safety operations, cables, and monitoring. A buffer zone to ensure security will be required.

In the open ocean, procedures need to be established to guide commercial and military ship traffic around OTEC plants, clusters, or parks. To minimize risks of credible accidents, OTEC siting areas should avoid known fishery regions, military zones, commercial ship-traffic lanes, potential resource exploration and exploitation zones, and designated ocean use areas (e.g., dredged material disposal sites, telephone cable areas).

4.3.3 Spill Contingency Plans

Small volumes of the working fluid released into the environment will not endanger the local population. However, if all or most of the working fluid is released into the surface waters at one time, serious episodes may ensue.

In a study performed by the U.S. Coast Guard to evaluate ammonia spills, the partitioning value (the fraction by weight that goes into solution) was estimated to be 0.6; the remaining fraction (0.4) will vaporize, rise rapidly, and be transported away from the site (EPA, 1977).

In subsurface ammonia spills, the partitioning value was estimated to be 0.85 to 0.90 with no vapor liberation; however, the surrounding water was reported to increase in temperature. Furthermore, the results expected from instantaneous versus continuous releases of ammonia were not resolved, nor were the possibilities of underwater explosions determined (EPA, 1977).

Another candidate working fluid for spill contingency considerations is Freon™. Freon™ will boil at the temperatures of surface seawater, and may produce toxic gases.

The minimal spill contingency plan should be specific to each platform site and contain the following:

- Notification list and telephone numbers of applicable government agencies
- List of spill cleanup companies including:
 - Emergency phone number of company and principal contact within the company
 - Main office location and phone numbers of branch offices
 - Emergency response radius to the site
 - Number of permanent employees and degrees of expertise
 - Spill contractor reliability, including training programs of employees and the number of years in operation
 - Inventory of available materials and equipment at manned locations of spill contractors
- Spill clean-up preparedness drills

Data from dispersion studies performed in advance would be useful to predict the speed, direction, and dispersion of the released materials at various water depths. Existing models may be modified to adjust to different characteristics of the various working fluids. Air transport models may be prepared, to estimate expected transport of the vapors formed during a large spill.

Chapter 5

RELATIONSHIP TO INTERNATIONAL, FEDERAL, AND STATE PLANS AND POLICIES

OTEC development will require the resolution of several legal, safety, and health issues prior to large-scale deployment, demonstration, and commercialization. Within this section, the International, Federal, and State legal, health and safety policies pertinent to OTEC are presented, along with the issues associated with siting of OTEC platforms.

5.1 LEGAL CONSIDERATIONS

The intent of this discussion is to present an overview of the complex interworking of the laws which affect OTEC; it is not intended to be a final legal statement for OTEC. This brief overview is drawn principally from Knight et al. (1977, 1978). The 1977 report includes a comprehensive review of the legal, political, and institutional aspects of OTEC (under the auspices of the American Society of International Law). A more recent report, entitled "International, Legal, Political, and Institutional Aspects of OTEC Demonstration and Development" is an application of the analysis contained in the 1977 report. Specific problems that have emerged in the development and demonstration of OTEC plants are considered. Further studies by the Department of Energy are underway to continue the OTEC legal issue evaluation.

5.1.1 Jurisdictional Limits

Land-based and moored OTEC platforms may be positioned within United States territorial seas and subsequently under the adjacent coastal state's jurisdiction. Moored and plant-ship OTEC plants may operate within the proposed 200-mile Economic Resource Zone (ERZ) of the United States. Plant-ships are expected to graze the high seas.

International practice divides ocean jurisdiction outside internal waters into three areas: (1) the territorial seas, (2) the exclusive Economic Resource Zone, and (3) the high seas (Knight et al., 1977). OTEC platforms may operate in all three areas, using surface and subsurface waters and the seabed.

5.1.1.1 Territorial Sea - There is no universally accepted limit of the territorial seas. A 1968 United Nations secretariat study indicated less than one-third of the coastal states practiced a territorial limit of less than 6 nmi, nearly one-half claimed 12 nmi or more, and a few claimed more than 12 nmi (Nanda, 1979). The United States presently claims 12 nmi; State jurisdiction applies to the first 3 nmi, Federal jurisdiction over the remainder. Within the 12 nmi region, the coastal government state has exclusive jurisdiction (Knight et al., 1977).

5.1.1.2 Economic Resource Zone - Seaward of the territorial sea is the high seas region which is subject to limitations of internationally recognized agreements. Typically, unilateral, bilateral, or treaty agreements are internationally accepted or recognized. An example of such a unilateral statement is the ERZ established by the United States. This concept is pending adoption by the Law of the Sea Conference.

There is increasing international acceptance of an ERZ extending from the baseline (from which the territorial sea is measured) to 200 nmi offshore. Within the ERZ, the coastal nation has sovereign rights over living and non-living resource uses, including such energy-producing uses as OTEC, although there is a duty to accommodate other legitimate uses of the ERZ, such as navigation and the laying and use of cables or pipelines.

The ERZ for OTEC regimes is illustrated in Figure 5-1.

5.1.1.3 The High Seas - Beyond the ERZ, all nations, coastal or landlocked, are free to use the oceans for the production of energy, subject to accommodation of other legitimate uses of the high seas, such as navigation, cable or pipeline laying, and fishing. The deep seabed beneath the high seas is subject to the jurisdiction, for resource purposes, of the International Seabed Authority (ISA), in accordance with the current Informal Composite Negotiating Text (ICNT). The present ICNT would require agreements with the coastal nation where its continental margin extends beyond 200 nmi. This preference has been expressed by Brazil, which would extend their jurisdiction out as far as 400 nmi (Nyhart, 1979).

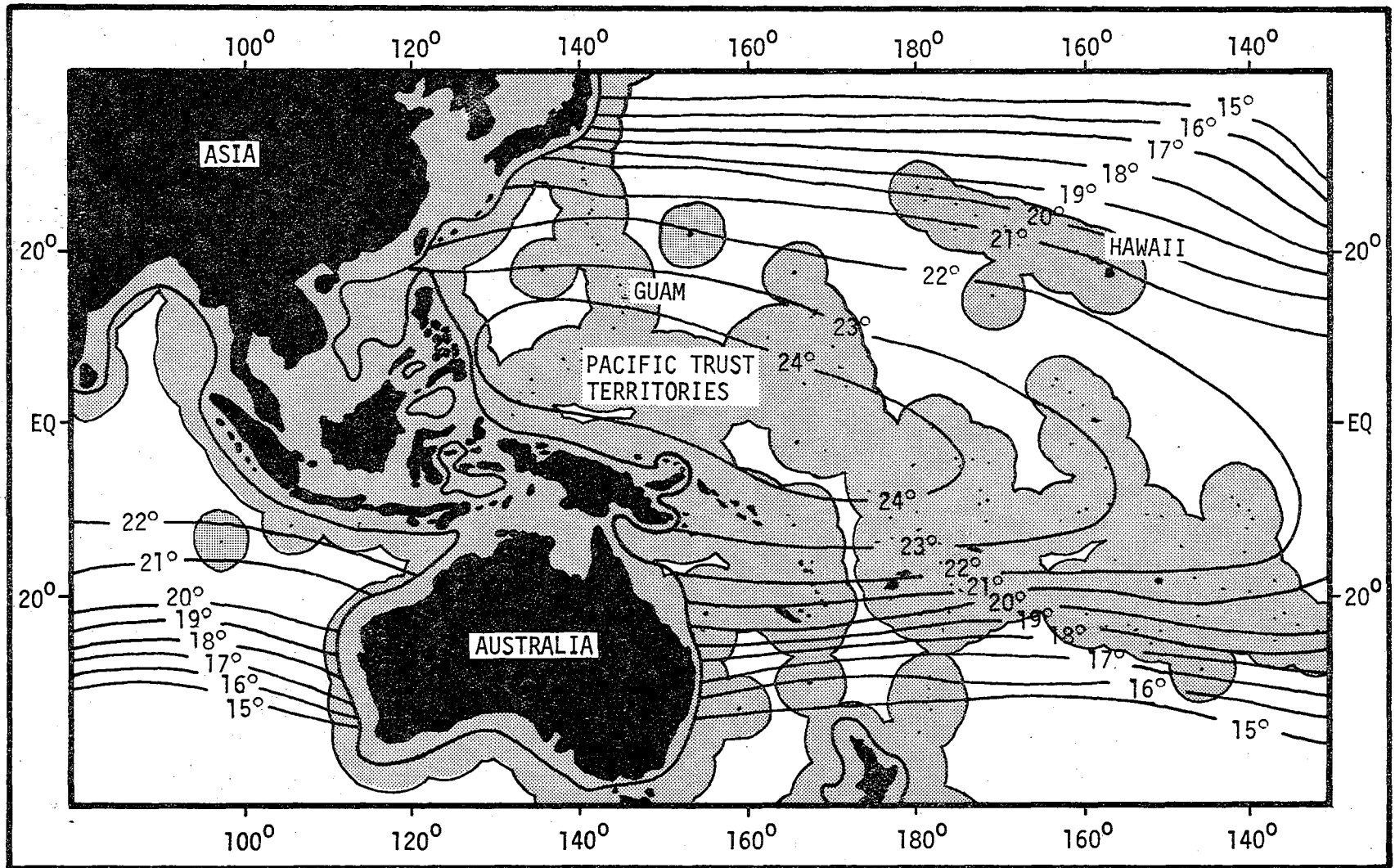

SHADED AREAS REPRESENT EXCLUSIVE ECONOMIC ZONES.
TEMPERATURES ARE IN DEGREES C.

BOUNDARY REPRESENTATIONS, NAMES AND SOVEREIGNTY
CLAIMS ARE NOT NECESSARILY AUTHORITY.

(U.S. DEPARTMENT OF STATE, 1978)

Figure 5-1. Economic Resource Zone for OTEC Regimes

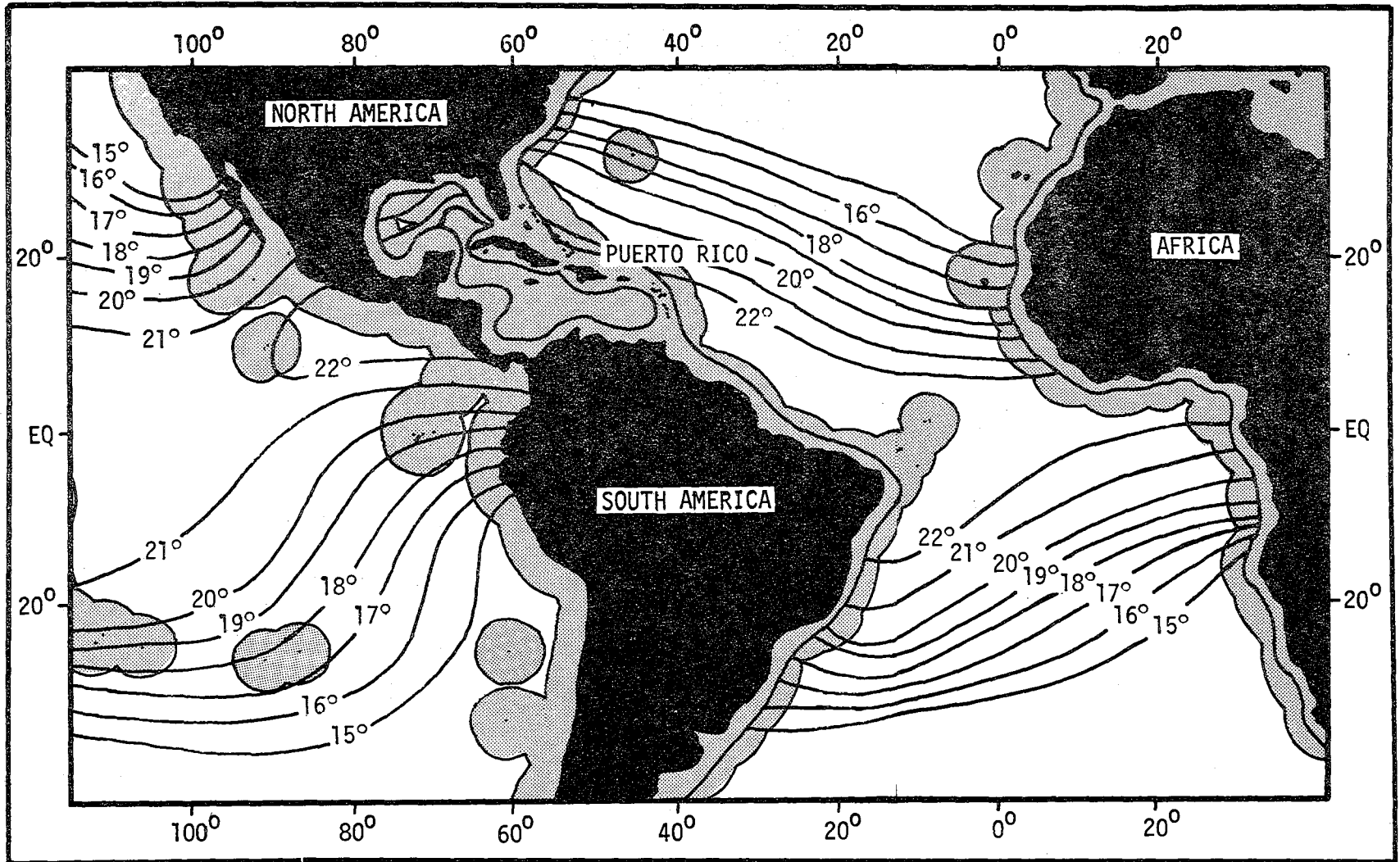

SHADED AREAS REPRESENT EXCLUSIVE ECONOMIC ZONES.
TEMPERATURES ARE IN DEGREES C.

BOUNDARY REPRESENTATIONS, NAMES AND SOVEREIGNTY
CLAIMS ARE NOT NECESSARILY AUTHORITY.

(U.S. DEPARTMENT OF STATE, 1978)

Figure 5-1. (continued)

5.1.2 State Issues

Under the Submerged Lands Act (43 U.S.C. 1301-1315, 1970, as cited in Nanda, 1979), Congress gave the States title and ownership of land and resources on the adjacent sea floor seaward to the territorial limit. However, the authority for navigation, flood control, and production of power was maintained under Federal control (Nanda, 1979). The Outer Continental Shelf Lands Act implemented the 1945 Truman proclamation, and provides (among other applications) the application of civil and criminal law of the coastal State to activities on the seabed of the Outer Continental Shelf (OCS), extending to artificial islands and fixed structures.

The territorial limit of state jurisdiction is 3 nmi; Federal jurisdiction extends from 3 nmi seaward, Florida and Texas are two exceptions, since each claimed limits in excess of 3 nmi before joining the Union. Florida claims 3 nmi on the Atlantic Ocean side and 9 nmi in Gulf of Mexico waters (DOE, 1979c). Texas claims 9 nmi along its coast. The U.S., in unilaterally declaring a 200 nmi ERZ, may extend coastal state territorial seas to 12 nmi, thereby creating uncertainty as to States' rights over various acquired zones (Nanda, 1979).

Coastal States have continued to claim a strong involvement in development of their coastal areas. In a recent challenge, in the case of United States v. Maine, the Supreme Court affirmed its earlier decision that the Federal government had paramount rights in waters beyond the territorial seas (Nanda, 1979).

The case of United States v. California in 1965, provided a determination of the Federal-State of California authority over submerged lands, mineral rights within inland waters, and the fixing of seaward territorial boundaries. Questions still exist as to the Federal paramount rights and the State interests in the marginal seas beyond 3 nmi. Specific references to OTEC-type facilities and vessel transit within the 3 nmi State of California boundary are not discussed.

Nanda (1979) reports that recent acknowledgment of the State's role in activities conducted in its waters is evident by the following developments: (1) inclusion of States' representatives on regional OCS advisory boards, (2) development of a new leasing system by the Department of the Interior to include the States' participation, and (3) 1978 amendments to the OCS Lands Act giving the State a role in decision-making processes for leased tracts.

Other laws which encourage State participation in offshore activities include the Coastal Zone Management Act of 1972 (CZMA) and the Deepwater Port Act (DPA) (Nanda, 1979).

The goal of the CZMA is the preservation, protection, development, and, where possible, restoration and enhancement of coastal resources (DOC, 1979c). Coastal zone management generally means making a rational choice among competing objectives. As part of the CZMA, States wishing to participate would have to develop coastal zone management programs that would:

- Identify important resources, areas, and uses within their coastal zone that need management or protection;
- Establish the framework to guide decisions of resource use and protection;
- Identify both landward and seaward coastal zone boundaries;
- Consider rational interest in planning for and siting of facilities; and
- Include legal authorities and organizational arrangements to implement the program (DOE 1979c).

The status of CZM programs for OTEC areas is presented in Table 5-1. The CZMA 1976 amendments created a fund for the establishment of a coastal energy impact program. The CZMA will play a key role in the siting of an OTEC platform in the State's waters.

TABLE 5-1
STATUS OF STATE COASTAL ZONE MANAGEMENT PROGRAMS
IN OTEC REGIONS

State or Territory	Actual or Estimated Federal Approval Date By Fiscal Year (ends 9/30)	Comments and Status*
Florida	?	Governor restructuring Program
Alabama	1979	State Hearings, March 1979; DEIS, May 1979
Mississippi	1980	Legislation enacted, March 1979
Louisiana	1979	State Hearing, April 1979; DEIS, July 1979
Texas	1980	Governor has submitted
Virgin Islands	1979	Approved, June 1979
Puerto Rico	1978	Approved
Hawaii	1978	Approved
Guam	1979	FEIS released June 1979
North Marianas	1980	Legislation pending
American Samoa	1980	Program under review

* As of June, 1979
Source: DOC, 1979c

Under the DPA, the Secretary of Transportation is given the responsibility and authority to license coastal facilities which may cause large-scale environmental impacts. The Governor of the adjacent coastal State has de facto veto power over the approval of the license (Linky, 1979).

Another required Federal permit is the National Pollutant Discharge Elimination System (NPDES), regulating the point source discharge of warm and cold waters. Normally, these permits are distributed by the appropriate

regional office of the Environmental Protection Agency. However, for platforms within state waters, the appropriate State office may have authority to issue and enforce the permit (DOE, 1979d).

The Commonwealth of Puerto Rico initiated a mock OTEC-licensing procedure to determine what agencies are involved and the necessary time for permit approval.

5.1.3 Federal Issues

Waters beyond 3 nmi are under jurisdiction of the Federal government. Federal issues include platform siting, licensing and operation. Because of the large number of Federal agencies involved, Knight et al. (1977) suggested the designation of a lead agency to coordinate the various approvals required.

Nyhart (1979) cautions that platforms sited in the ERZ are still on the high seas according to international law, and, to the extent of not interfering with other ocean uses, siting of OTEC platforms is acceptable. Prospective developments necessitate the establishment of an ERZ 200 nmi from shore that would include OTEC activities.

5.1.3.1 Licensing - The Federal agencies involved in OTEC licensing are listed in Table 5-2. Each of their regulations must be addressed prior to OTEC siting. Failure to comply with all specifications will result in denial of appropriate permits or approvals. If designation of a lead agency is made, it would reduce the lead time required to receive permits. Congressional approval may be required for agency designation. Candidate agencies include (but are not limited to): Army Corps of Engineers, U.S. Coast Guard, Environmental Protection Agency, and the Department of Commerce (principally NOAA).

Some arguments raised about OTEC revolve around the potential adverse impacts that may result from development. Potential impacts would not be contained within the OTEC region, but would extend downstream of the platform. In the case of the Gulf of Mexico OTEC park, the discharged waters pass the coasts of Cuba and the Bahamas, and may later affect the climate of Europe

**TABLE 5-2
FEDERAL AGENCIES INVOLVED IN OTEC LICENSING**

AGENCY	AREA OF RESPONSIBILITY	LEGISLATION	RESOLUTION
Army Corps of Engineers	Implantation of mooring equipment Dredging to implant positioning equipment Siting	River & Harbor Act (1899) Marine Protection, Research & Sanctuaries Act (1972) Federal Water Pollution Control Act (1972) River & Harbor Act (1899)	Petition Corps of Engineers for approval Petition Corps of Engineers and Environmental Protection Agency Petition Corps of Engineers for approval
Department of Transportation ●U. S. Coast Guard ●Federal Aviation Administration	Enforcement of all Federal Laws on navigable waters Safety and health Navigation aids for safety Plant manufacture and construction Siting and emergency preparedness: Procedures Siting Operation: Dangerous cargo Manning Sewage treatment Heliport licensing	General Statutory Authority General Statutory Authority General Statutory Authority Section 395(a), Title 46 U. S. Code and others Coast Guard is empowered to prescribe rules and regulations for vessel safety inspection and certification As above See Safety/Health Section 5	Follow existing published guidelines and request approval for others As above As above Construction, inspection and approval by USCG and American Bureau of Shipping (also see Safety and Health, Section 5) Request/review applicable USCG documents and petition for approval As above See Safety/Health Section 5
Environmental Protection Agency	Point source discharge Hazardous substance control Ocean disposal of materials	Federal Water Pollution Control Act (1972)/ Clean Water Act and Amendments (1977) Federal Water Pollution Control Act (1972) Marine Protection, Research and Sanctuaries Act (1972)	File application with EPA Regional Administrator of the Region for a National Pollutant Discharge Elimination System (NPDES) permit to discharge Develop control plan for substance, develop spill contingency plan and submit to EPA Request approval from EPA Regional Administrator
Department of Energy	The funding agency must prepare an Environmental Impact Assessment/Statement	National Environmental Policy Act 1969	Environmental Impact Assessment and Statement (if required)
Department of Defense	Siting	Congress has delegated responsibility to restrict use of seabed, waters and air space of the territorial sea, contiguous zone and outer continental shelf	Approval required by Deputy Asst. Secretary of Defense only if site is in a defensive sea area.
Department of Interior ●Bureau of Sport Fisheries and Wildlife ●U. S. Geological Survey	Jurisdiction over conservation, development, and management of fish and wildlife resources Jurisdiction over Federal lands for leasable minerals	Not applicable Not applicable	Will be involved in NEPA Environmental Impact Evaluation Contact prior to siting to preclude use of area for mineral production
Department of Labor ●Occupational Safety and Health Administration	Enforce occupational Safety and Health Standards	Occupational Safety and Health Act of 1970	See Safety/Health Section 5
Department of Commerce ●National Oceanic and Atmospheric Administration	Siting Environmental Monitoring and Research	Marine Protection, Research, and Sanctuaries Act (1972) National Ocean Pollution Research Development Monitoring Planning Act of 1978	Request approval Interagency agreement with EPA

through the Gulf Stream (Nyhart, 1979). Nyhart (1979) suggests that the U.S. may choose to comply with international environmental monitoring through the United Nations to alleviate international fears of OTEC's environmental impacts. The same potential impacts may affect fishing, shipping, and coastal activities (Nyhart, 1979).

Specific legislation which influences OTEC licensing includes the National Environmental Policy Act (NEPA), Federal Water Pollution Control Act, Clean Water Act and Amendments, and the Studds Bill (Ocean Thermal Energy Conversion Act of 1980). These are discussed in the following paragraphs as they relate to OTEC.

NEPA requires an EA or an EIS on the expected environmental consequences of a Federally funded action before the action occurs. Because of the magnitude of OTEC development, demonstration, and commercialization, environmental impact statements are likely to be required for the first series of large-scale OTEC platforms. Eventual long-range ocean use planning may parallel trends established for ocean disposal and oil drilling in the designating of ocean space for particular usage.

The Federal Water Pollution Control Act, as amended (33 U.S.C. 1251, et seq., as cited in Nanda, 1979), established the NPDES to regulate point source discharge to surface waters. This permit will likely be required for OTEC plants. The NPDES permit process is described in detail in the Federal Register, June 7, 1979. A brief overview is presented in the following paragraphs. The process to obtain a permit generally involves the following steps (44 CFR 32854):

1. State certification of the application
2. Development of the permit
3. 30-day period of public review and comment
4. Permit issuance

When no guidelines exist and the permit is complicated, at least 6 to 18 months may be required for the development of the permit (DOE, 1979d).

Two types of limitations can be incorporated into a NPDES permit: (1) effluent guidelines which are technology-based, or (2) coastal State water quality standards. There are no established technology-based guidelines for OTEC (DOE 1979d). In Federal waters NPDES permits are issued by the applicable Environmental Protection Agency regional office.

In setting permit limits, the EPA personnel may consider: (1) technology-based permit limits which apply at the discharge point, (2) water quality standards, (3) a discharge limitation based on toxicity data, or (4) use of the steam-electric industry effluent guidelines for the basis of an OTEC permit (DOE, 1979d). The Clean Water Act, Section 401(a)1, authorizes EPA to establish limits based on EPA's best engineering judgment. The EPA limits are subject to challenge, if industry feels that they are too stringent or restrictive (DOE, 1979d).

In developing the best available technology to control the release of certain effluents, EPA states that greater emphasis will be placed on toxicity-based limits rather than on technology-based limits, particularly if the latter limits are inadequate for toxicity elimination (DOE, 1979d). There are no established toxicity guidelines for organisms which occupy the OTEC siting regions.

The Clean Water Act and Amendments (1977), Section 316(b), governs the cooling water intake structures for any facility which withdraws large volumes of cooling waters. Section 316(b) provides a means to demonstrate to EPA that the design of the intake represents the best available technology and that no adverse environmental impacts are occurring (DOE, 1979c).

The Studts Bill (Ocean Thermal Energy Conversion Act of 1980) will have a significant influence on OTEC development (Nossaman, et al., 1979). This sweeping legislation is in draft form and includes four titles: Title I--Findings, Purposes, and Definitions; Title II--Licensing of Ownership, Construction, and Operation; Title III--Enforcement Authority; and Title IV--Miscellaneous Provisions. The enactment of the Studts Bill will provide a firm legal base on which to resolve many uncertainties surrounding OTEC development (Yarema, 1979).

5.1.3.2 OTEC Liability - Gas and oil exploration and exploitation on the continental shelf were the first major technological advances into the ocean and expanded ocean use from transportation and fishing. It also created substantial problems with liability issues. Sources of liability for failure to comply with existing or customized standards or regulations for OTEC may be resolved through Federal regulatory law, U.S. civil and criminal law, U.S. maritime law, state law, and (least likely) international law. A more detailed discussion is given by Knight et al. (1977).

5.1.3.3 Federal Regulatory Law - Federal regulatory law furthers public safety, health, and welfare. Activities such as construction, layout and design, financing, initial and periodic certification and inspection, operational processes, systems safety, customs, navigation, and environmental controls fall within the Federal regulatory regime.

5.1.3.4 Criminal and Private Law - Tort, contract, and similar legal issues will likely be resolved by civil and criminal law in the Federal courts. However, Nyhart (1979) suggests that the extent to which Federal criminal law will apply to OTEC platforms located within the ERZ must be resolved. In terms of private law, there are two bodies of law available to OTEC policy planners: the maritime law or the law of the adjacent State (Nyhart 1979). Maritime law is designed to respond to problems with legal solutions arising from the conduct of the sea-transport industry. Nyhart recommends that admiralty and maritime law be applied to OTEC platforms, with State law serving as a supplement only where necessary.

5.1.4 International Issues

Due to increasing international acceptance of an ERZ, the siting of OTEC platforms in non-exclusive waters is likely. On the high seas, the freedom-of-the-seas concept gives every nation unrestricted access; however, exclusive use over a prolonged period is not implied. The 1958 Geneva Convention on the Law of the Sea formalized this concept, and provided for various uses such as commercial navigation, fishing, and the laying of pipeline or cable. If any conflicts of use occur, the doctrine of "reasonable

use" is applied (Nanda, 1979). In the absence of specific international legislation or regulation, OTEC use may fall under the "reasonable use" doctrine (Nanda, 1979).

5.1.4.1 Law of the Sea - At the present time there are no international regulatory mechanisms specifically applicable to OTEC. The four 1958 Geneva Conventions on the Law of the Sea are still the prevailing international laws, although many nations view parts of them as overruled by more recent developments (DOE, 1979c).

OTEC may be regulated internationally by one of two options: (1) modification of existing mechanisms including but not limited to the Informal Composite Negotiating Text (ICNT), International Seabed Authority (ISA), or the Inter-Governmental Maritime Consultative Organization (IMCO); or (2) establishment of new mechanisms.

The ICNT is the product of more than four years of Law of the Sea negotiations. Articles applicable to OTEC uses are obtaining general agreement. The ICNT generally attempts to formalize the heritage-of-mankind concept, which states that the seabed, ocean floor, and subsoil beyond the jurisdiction of the coastal state are resources for the common heritage of mankind. The United Nations emphasized this concept in 1970 through Resolution 2749 (Nanda, 1979).

The basis of this philosophy led to the controversy over deep ocean mining. The underdeveloped countries claim entitlement to equal shares of resources which the mining would provide. In response, the Law of the Sea suggested the formation of the ISA, which would oversee deep ocean mining activities. ISA refers specifically to the in situ mineral resources; it may be extended to cover OTEC activities. By ISA interpretation, OTEC moored platforms could well be under ISA influence.

IMCO is another option to consider for modification in order to establish international standards for OTEC (Nyhart, 1979).

5.1.4.2 Criminal and Private Law - The determination as to whether OTEC platforms are classified as vessels or other entities will clarify some legal questions. It is expected that laws of countries under whose flag the OTEC platforms are registered will apply. Thus, U.S. vessels will resolve tort, contract, and similar legal issues through the civil and criminal law system in Federal courts (DOE, 1979c). Nyhart (1979) suggests that a portion of admiralty law (in conjunction with civil and criminal law) be applied to OTEC platforms, while maritime laws govern private law.

5.1.4.3 Environmental Law - Many of the international concerns associated with OTEC stem from potential environmental impacts associated with commercialization.

The Law of the Sea has been concerned with environmental issues on the high seas. The ICNT, Part XII, has 46 articles for protection and preservation of the marine environment. The 1972 United Nations Conference on Human Environment emphasized that states are responsible and liable for transnational environmental damages which originate from their activities. It is not clear whether this same flag-state liability extends to vessels which operate on the high seas.

United Nations activities have also been instituted through the United Nations Environmental Program, Regional Seas Program. This organization is developing action plans for several large regional bodies of water, including the Mediterranean Sea, Gulf of Arabia, Red Sea, Gulf of Guinea, Caribbean Sea, East Asian Seas, and the South Pacific (Nanda, 1979).

U.S. flag vessels will be regulated by requirements for environmental protection, as outlined in NEPA legislation.

5.1.4.4 OTEC Protection - The 1958 Law of the Sea Convention of the Continental Shelf originated the Safety Zone Concept which provides a 500-m buffer zone around an ocean structure. This buffer zone is likely to be based on the extent of the watch circle rather than platform position. This buffer zone is not valid in recognized sea lanes essential to international navigation, but ships of all nationalities and origins have accepted the 500 m buffer zone as an appropriate boundary.

The siting of OTEC platforms close to shore may increase the chance of collision. Nearly 85% of all ship collisions occur within 8 km of shore (Knight et al., 1977). The frequency decreases exponentially with increasing distance from shore, with only 10% of the collisions occurring from 8 to 40 km offshore, and less than 5% at greater than 40 km at sea. This problem will be mitigated by adequate lighting, vessel traffic control and by bordering OTEC platforms with appropriate warning devices (Knight et al., 1977).

In problems of deliberate interference, it is desirable to secure international acquiescence through a treaty or customary law developed by the coastal State authorizing normal police powers to enforce domestic laws to prevent interference (Knight et al., 1977).

5.2 HEALTH AND SAFETY REGULATIONS

In March of 1979, the Department of Energy Order Number 5481.1, Safety Analysis and Review System for DOE Operations (SAR), established the uniform requirement to evaluate, prepare and review the safety of DOE operations. The SAR draft guidelines have been published to assure a uniform and systematic approach to evaluate safety (DOE, 1979e). The SAR must be prepared for OTEC operations. Further details of the SAR are described in 5.2.1.2.

In addition to the SAR, the health and safety aspects outlined in this section define various operational procedures inherent in most ocean-going vessels, but related specifically to OTEC platforms. In defining precautions, it was necessary to make certain assumptions (e.g., crew size and composition, system configuration). Some requirements, either between regulating agencies or within one agency, may be overlapping; however, this has been taken into account and requirements will be acceptable in all cases. The U.S. Coast Guard will be the primary regulating agency, and exceptions will be noted where appropriate. Land-based OTEC plants will fall under the Occupational Safety and Health Administration (OSHA).

To facilitate daily routine operations, complete procedural manuals will be written for each operating entity of OTEC. The manuals will provide detailed operation, safety, or emergency procedures, and define individual responsibilities.

5.2.1 General Safety Considerations

5.2.1.1 Hospital - As outlined in Vessel Rules and Regulations (CG-257), Subpart 92.20, Section 35, OTEC platforms must be provided with a hospital. The hospital must have at least one berth for every 12 members of the crew. Due to the size and inherent hazards of the equipment (e.g., CWP) on OTEC platforms, the hospital should be prepared to handle major injury cases. It must also be able to treat acute respiratory problems, burns, and diving diseases. Surgical and treatment (examination) rooms should be provided, as outlined in the above reference. Hospital staffs, whether medical or paramedical, must be adequately trained to cope with anticipated problems. If paramedical personnel work independently of physicians, they must carry Merchant Marine Documentation (Licensing of Personnel CG 191, Subpart 10.25, Sections 9 and 11). A physician qualified in the pertinent problems must be maintained on 24-hour call to advise and, if required, be available to take over in emergency cases. Apart from specific paramedical or medical skills required for OTEC platforms, medical and paramedical personnel should be familiar with general operations of OTEC systems, be capable of defining hazards before they cause injury, and contribute to the development of additional safety procedures.

5.2.1.2 Safety Analysis Report - A brief overview is presented on the purpose, scope, basic document requirements and updating schedule of the SAR (DOE, 1979e).

(a) Purpose

The information contained in the SAR is a documentation of the safety analyses performed for the operation in accordance with DOE objectives. The objectives of the preparation and review of the SAR include: (1) systematically identify potential hazards, (2) analyze potential impacts (3) describe reasonable measures to eliminate,

control or mitigate the identified hazards, and (4) serve as a documentation of DOE management authorization based on an objective safety analysis assessment.

(b) Scope

The DOE is responsible for implementing the SAR guidelines; the analyses must be conducted by the organization with direct operating responsibilities. The SAR must be completed for all activities that DOE has assumed health, safety or environmental protection responsibility for, with the exception of: (1) nuclear safety of weapon designs, (2) construction related work activities, and (3) operations with hazards of a type and magnitude routinely encountered and/or accepted by the public.

(c) Basic SAR Requirements

A SAR must address the following topics: (1) description and evaluation of the site, (2) description of the facility and/or operations, (3) design criteria for systems, components, and structures, (4) identification of hazards, (5) physical design features and administrative controls provided prevention and mitigation of potential accidents, (6) potential accidents including those resulting from natural phenomena, (8) probability of occurrence and predicted consequences of accidents (expressed in qualitative or quantitative terms), (8) normal and emergency operating procedures to be used; and operational limitations.

The SAR is completed in two phases: a preliminary SAR during the design phase and a final SAR submitted prior to operation.

(d) Updating

The alteration or significant modification of a facility requires the update to the Safety Analyses Documentation.

5.2.2 Platform Considerations

There are risk differences between moored and grazing OTEC platforms; however, the hazards are generally the same. The safety advantage of a moored platform is that its position is fixed within a known watch circle so that passing vessels can avoid the area.

The grazing platform presents additional hazards which require continual notification--i.e., broadcasting position updating so that marine traffic can adjust navigational tracks in response to the changing OTEC platform position. A good general description of the platform navigational hazards was compiled by General Electric (1977). In this discussion, some of the procedures, references, and safety precautions for minimizing health and safety risks are presented.

Due to the innovative nature of OTEC platforms, the nearest parallel that can be made is to the risks and safety of offshore drilling platforms. By reviewing drilling platform accidents, it is apparent that careful consideration and planning are needed for all eventualities.

5.2.2.1 Platform Classification - The preoperational platform (OTEC-1) is classified as an "Oceanographic Research Vessel" under Title 46, Subchapter U; however, future OTEC platforms may be classified differently. Current regulations such as the U.S. Coast Guard's "Requirements for Mobile Offshore Drilling Units or Rules and Regulations for Cargo and Miscellaneous Vessels" will be applied or rewritten to accommodate commercially operating OTEC platforms (USCG, 1973 and 1978). The U.S. Coast Guard is currently proposing rules for "Unregulated Hazardous Working Conditions on the Outer Continental Shelf" (USCG, 1979b). The rulemaking efforts will significantly impact platform and personnel safety.

5.2.2.2 Crew - Future OTEC platforms will be production-intensive facilities. Major tasks will be stationkeeping and marine platform maintenance. However, this does not reduce the need for all personnel (marine and process systems included) to have a complete understanding of the ramifications of at-sea operations. Requirements are presented in IMCO (1978) for the training of seafaring personnel.

5.2.2.3 Regulating Agencies - The following lists of regulatory and advisory agencies involved in OTEC are as complete as possible, and in many cases a specific agency's recommendations have been incorporated into a senior agency's requirement.

(a) U.S. Government Agencies - Agencies involved in the licensing or certification of OTEC platforms are listed below:

- Army Corp of Engineers (CE)
- Department of Defense (DOD)
- Department of Energy (DOE)
- Department of Interior
 - U.S. Geological Survey (USGS)
 - Bureau of Sport Fisheries and Wildlife (BSFW)
- Department of Labor (DOL)
 - Occupational Safety and Health Administration (OSHA)
- Department of Transportation (DOT)
 - Federal Aviation Administration (FAA)
 - U.S. Coast Guard (USCG)
- Environmental Protection Agency (EPA)
- Federal Communications Commission (FCC)

- Individual State or Locality Regulations (dependent on OTEC geographical locations)
 - U.S. Navy Military Specifications (MILSPEC)
 - The United States Code (USC), as it governs the conduct of, and is referenced by, any of the above agencies.

(b) Non-Governmental Standardization Organizations - Other non-Governmental organizations that may be involved in standardization are listed below. These organizations may offer advice or guidelines, but will not issue permits:

- American Bureau of Shipping (ABS)*
- American Boat and Yacht Council, Inc. (ABYC)
- American National Standards Institute (ANSI)
- American Society of Mechanical Engineers (ASME)
- American Society of Testing and Materials (ASTM)
- American Welding Society (AWS)
- Compressed Gas Association (CGA)
- Fluid Controls Institute, Inc.
- Manufacturers' Standardization Society of the Valve and Fittings Industry (MSS)
- Marine Department, Underwriters' Laboratories, Inc.
- National Fire Protection Association (NFPA)
- National Fluid Power Association (NFPA)
- Tubular Exchanger Manufacturers' Association (TEMA)
- Underwriters' Laboratories Inc. (UL)

* Authorized U.S. Certification Bureau (load line)

(c) Publications - The contractor(s) constructing future OTEC platforms must be familiar with all publications pertinent to the regulation of marine operations and those which specifically apply to OTEC systems. The regulatory agencies listed above continually update and publish regulations. Government agencies publish updates, when appropriate, in the Federal Register.

5.2.3 Personnel and Process System Safety

In order to implement vessel safety programs, aside from those established or required by the U.S. Coast Guard, a system safety analysis should be established for each OTEC platform. A report entitled "System Safety Analysis of a Commercial Vessel" is an excellent guideline (USCG, 1977).

5.2.3.1 Personnel - There are no universally applicable regulations concerning personnel safety and training requirements for offshore operations. The U.S. Geological Survey administers some training procedures for offshore drilling operations. The Occupational Safety and Health Administration (OSHA) covers some offshore industrial safety, and the Coast Guard covers marine safety.

The Coast Guard bi-monthly publication, "Proceedings of the Marine Safety Council, CG-129", documents the need for adequate training programs and lists the dates and location of such programs, with outlines of training requirements and procedures. OTEC platforms will present some unique personnel risks and safety requirements. A careful evaluation of all problems will facilitate formulation of a composite safety training program.

All employed personnel on an OTEC platform must have a thorough understanding of the personnel risks of at-sea operations. Correct action by personnel must be strictly adhered to and fully understood for the following typical marine occurrences:

- Man Overboard
- Firefighting

- Collision
- Severe Weather
- Grounding
- Flooding
- Acts of War or Sabotage
- Lifeboat Use
- Lifejacket Use
- Respirator Use
- Weather-Related Difficulties
- First Aid
- Diver Accident Aid
- Any Combination of the Above

It should be understood that the dividing line between marine platform and personnel safety and risks is very fine. Often the events which cause a vessel accident involve personnel errors. Therefore, an integrated training program of marine safety must be established for all OTEC personnel, and continual drills should be conducted per Coast Guard regulations (USCG 257).

5.2.3.2 Process System - A variety of systems and subsystems will be present on OTEC platforms. A summary of the various systems and subsystems potential hazards appears in Table 5-3.

(a) Chemical Systems - There have been a number of chemicals discussed in OTEC literature; however, this discussion is limited to those chemicals likely to be used on OTEC platforms: anhydrous ammonia, Freon™ (R-11 or R-500), and chlorine.

Those with responsibility and concern for the chemicals carried in bulk aboard the OTEC platform must be familiar with USCG publication 388, "Chemical Data Guide".

Chlorine will likely be generated on the platform (rather than stored in bulk quantities), since ammonia will be stored on the platform and these two chemicals explode when combined (NFPA, 1971); the relative location of each chemical must be carefully considered. The potential release of ammonia into

**TABLE 5-3
POTENTIAL HAZARDS SUMMARY**

OTEC BULK CARGO HAZARD IDENTIFICATION									
AGENT	SOURCE	PHYSICAL STATE	HANDLING PROCEDURES	CREW HAZARD LEVEL	OTEC HAZARD LEVEL	TYPE OF HAZARD	NEUTRALIZING AGENT	HAZARD MAINTENANCE	COMMENTS
ANHYDROUS AMMONIA NH ₃	1	1,2	1,2,3	1-2	3	1,2,3	Water	1,2,3,4,5,6	Protective clothing and breathing equipment may be required
CARBON DIOXIDE CO ₂	3	2	6	3	4	4	Air Circulation	1	Breathing equipment may be required. Diver hazard.
CHLORIDE Cl	3	1,2	1,2,3,5,6	1-2	3	3,7	Ventilation	1,2,3,4,5,6	Protective clothing and breathing equipment may be required.
*FREON TM	1,5	1,2	1,2	3	1	3,4	Ventilation	1,5,6	Forms phosgene gas when exposed to flame
ELECTRICAL CONNECTIONS	2,3	--	3	1	4	6	Insulation	2,3,4,5	Protective clothing and devices required
LUBRICATING OILS	3	1	2,3	3-4	3	1	Containment Boom-Absorbents	3,4,5,6	Spill hazard
OXYGEN	5	1,2,4	1,2,3,6	1	1-2	2	Ventilation	1,2,4,5,6	Supports combustion
SOURCE	PHYSICAL STATE	HANDLING PROCEDURE	CREW HAZARD LEVEL	OTEC HAZARD LEVEL	TYPE OF HAZARD	HAZARD LEVEL MAINTENANCE			
1. Working Fluid	1. Liquid	1. Containment	1. High	1. High	1. Flammable	1. Circulation			
2. Process Product	2. Gas	2. Storage	2. Medium	2. Medium	2. Oxidant	2. Sensor Monitoring			
3. Process Requirement	3. Solid	3. Transfer	3. Low	3. Low	3. Toxic/Irritant	3. Visual Monitoring			
4. Fuel	4. Cryogen	4. Shipment	4. None	4. None	4. Sufficant	4. Special Precaution			
5. Support Requirement		5. Controlled Application			5. Explosive	5. Personnel Training			
		6. Ventilation			6. Shock	6. Containment			
					7. Corrosive				
<p>NOTE: Other hazardous materials such as acetylene, paints and thinners, etc. will be carried aboard; however, they have not been listed above due to their being carried in minimal quantities and their hazards should be readily discernible.</p> <p>*Source: USCG 388, 1976, Chemical Data Guide for Bulk Shipments by Water. Adapted from Mallinckrodt, 1976, 1977</p>									

5-23

Adapted from Mallinckrodt, 1976, 1977

the atmosphere must be evaluated. The minimum safety distances from residential buildings were suggested in a report prepared by the Environmental Protection Agency, and are listed in Table 5-4.

TABLE 5-4
SAFE LOCATION OF AMMONIA CONTAINERS

Nominal Capacity ₃ of Container, (m ³)	Minimum Distances, in Meters, from Container to:		
	Line of Adjoining Property that may be built on Highways and Main Line of Railroad	Place of Public Assembly	Institution Occupancy
Over 1.9 to 7.6	7.6	46	76
Over 7.6 to 114	15.0	91	152
Over 114 to 379	15.0	137	229
Over 114 to 379	15.0	137	229
Over 379	15.0	183	305

Source: EPA, 1977

The following listed data are pertinent to anhydrous ammonia, Freon™, and chlorine. Recommended specification precautions and procedures will be outlined in pertinent process systems discussions.

- Anhydrous Ammonia (Mallinckrodt AR Laboratory Chemicals, 1976-77):
 - Incompatible with mercury, halogens, calcium hypochlorite, hydrogen fluoride
 - Physical state: gas
 - Solubility: extremely high, greater than 50 g 100 m⁻¹ H₂O
 - Boiling Point: -33.33°C (-28°F)

- Vapor Density: 0.6 units (ratio of vapor or gas to equal volume of air)
- Ignition Temperature: 651.11°C (1204°F)
- Flammability Limits: (percent volume in air)
 - Minimum concentration at which explosion cannot occur: 16%
 - Maximum concentration at which explosion cannot occur: 25%
- Hazard Rating:
 - Health: Short exposures could cause serious temporary or residual injury, even if promptly treated
 - Flammability: Must be preheated before ignition can occur
 - Type of Hazard: Flammable material, gas, or vapor rapidly toxic or extremely irritating on exposure for a short time or to low concentration
 - Life Hazard: Primary skin irritant, can cause severe eruptions or burns. Respiratory threshold limit value = 50 ppm
 - Precautions: Keep away from heat, sparks, open flame; avoid spilling, contacting skin, eyes, or clothing. May require gloves, goggles, apron, etc. Use adequate ventilation, avoid breathing fumes, mists, gases or vapors. Personal respiratory protection may be required
 - Fire Extinguishing Method: water spray

Ammonia, in high concentrations, is an irritating and corrosive compound which can damage eyes, mucous membranes, and skin, and (on inhalation) inhibit respiration. Upon removal from an ammonia atmosphere, an exposed individual usually recovers in a few days; in extreme cases, eye damage can be permanent. Severe lung exposures can be fatal.

- R-11 (Van Nostrand Reinhold Co., 1979) Known as refrigerant 11 or Fluorotrichloromethane; Freon™.

- A colorless liquid with a molecular weight of 137.38, a melting point of -111°C , a boiling point of 24.1°C , and a density of 1.484 at -17.2°C
 - Health hazard: the lowest published lethal dose is 10 g/liter for 20 minutes. A potential hazard exists because R-11 reacts violently with aluminum
 - R-11 is a mild inhalation irritant and causes reversible tissue changes which disappear after exposure stops
 - Exposure to high concentrations may cause narcosis and anesthesia
 - R-11, when heated to decomposition, emits highly toxic fumes of chlorides including phosgene and fluorides
 - R-11 is referenced under Freon[™] as a cargo group 36 (USCG, 1976)
- R-500 (Van Nostrand Reinhold Co., 1979; CRC, 1973)
 - An azeotrope of refrigerant 12 with a molecular weight of 105.5, a boiling point of -33°C , and a freezing point of -158.9°C
 - Human and disaster hazards essentially equivalent to R-11
- Chlorine (Mallinckrodt AR Laboratory Chemicals, 1976-77):
 - Incompatible with ammonia, acetylene, butadiene, benzene and other petroleum fractions, hydrogen, sodium carbides, turpentine, and finely divided powdered metals
 - Physical State: gas
 - Solubility: Fairly high, nearly $5 \text{ g (100 ml H}_2\text{O)}^{-1}$
 - Boiling Point: -34.4°C (-30°F)
 - Vapor Density: 2.5 units
 - Type of Hazard: Gas or vapor highly toxic or extremely irritating on exposure for short time or to low concentrations. Oxidizing material: contact with other combustible may cause fire. Irritant, sensitizer, corrosive; causes skin irritation or burn
 - Hazard Rating: Short exposure could cause serious, temporary or residual injury even if promptly treated; not flammable
 - Reactivity: Normally stable except in combination with certain other materials or at elevated temperatures and pressures

- Life Hazard: Primary skin irritants can cause burns and skin eruptions. The respiratory threshold limit value = 1 ppm
- Precautions to Take: Not to be handled unless safety precautions are understood. Use adequate ventilation, avoid breathing fumes, mists, gases, or vapors. Personal respiratory protection may be required. Avoid contact with acids, combustibles, and moisture

Chlorine is a product carried in large tonnages, and is fairly typical of the more hazardous gas cargos. When sufficient concentration of chlorine gas is present, it will irritate the mucous membranes, the respiratory system, and the skin. Large amounts cause irritation of the eyes, coughing, and labored breathing. Symptoms of exposure to high concentrations are gagging and vomiting, followed by difficult breathing. In extreme cases, the difficulty of breathing may result in death by suffocation. Liquid chlorine in contact with the eyes or skin will cause local irritation and/or burns.

Phosgene, a potential reaction product of Freon™ and heat, has the following characteristics:

- Phosgene (Van Nostrand Reinhold Co., 1979)

- A colorless gas or volatile liquid with a molecular weight of 98.92, a melting point of -118°C , a boiling point of 8.3°C , a density of 1.37 at 20°C , and a vapor pressure of 1,180 mm at 20°C
- Health hazard: inhalation mode of exposure LC_{50} (human) = $3,200 \text{ mg liter}^{-1}$; inhalation lowest published (human) = 25 ppm for 1/2 hour
- High irritation to eyes and mucous membrane. In the presence of moisture, phosgene decomposes to form hydrochloric acid and carbon monoxide
- Concentrations of 3 to 5 mg liter^{-1} in air causes irritation of the eyes and throat with coughing. 25 mg liter^{-1} is dangerous for exposure lasting 30 to 60 minutes and 50 mg liter^{-1} is

rapidly fatal after even short exposure. There may be no immediate warning that dangerous concentrations of the gas are being breathed

- Reacts violently with aluminum, isopropyl alcohol, potassium and sodium
- Disaster Hazard: highly dangerous when heated to decomposition or when in contact with water or steam; will react to produce toxic and corrosive fumes

OTEC Plant-Ship Products - Ammonia

- Compounds used or formed include ammonium nitrate, anhydrous ammonia, and nitric acid

• Ammonium Nitrate (Van Nostrand Reinhold Co., 1979)

- Colorless crystals with a molecular weight of 80.05, a melting point of 169.6°C, a boiling point 210°C at 11 mm, and a density of 1.725 at 25°C
- Has been discussed as a fertilizer end product of OTEC process plants
- Ammonium nitrate is a high-order explosive which has been proven to be a dangerous ship cargo, and has destroyed whole cities (Texas City Disaster, April 1947)
- Is extremely unstable in combination with diesel fuel (DuPont, 1969)
- The National Fire Protection Association and the U.S. Coast Guard have published specific instructions for handling and storage of ammonium nitrate (DuPont, 1969; USCG, 1976)

- Threshold: there are reports of faintness and low blood pressure in workers exposed
- Fire Hazard: may ignite when mixed with acetic acid
- Explosion Hazard: may explode under confinement and high temperatures. Explosions have occurred in ships' holds, etc. There have been warehouse fires which did not detonate. This material explodes more readily if contaminated and must be kept cool and unconfined. Can react violently or explode when mixed with powdered metals
- Disaster Hazard: dangerous; heat and confinement may explode it; when heated to decomposition, emits highly toxic fumes of oxides of nitrogen

● Nitric Acid (Van Nostrand Reinhold Co., 1979)

- An extremely dangerous cargo. It is a powerful oxidizing agent and reacts violently with water to produce heat and toxic and corrosive fumes

OTEC Plant-Ship Products - Aluminum

- Dependent upon the type of process used, the hazards of aluminum production and byproducts vary. Fluorine-containing gases from alumina reduction cells present one hazard. Fluorine gases are highly irritating, toxic when heated, and will react with water or steam to produce heat and toxic corrosive fumes. There has been some record of lung damage due to inhalation of finely divided alumina (aluminum oxide). There are other personnel and platform hazards possible in aluminum production which will be specific to each manufacturing process.

Irrespective of chemicals or processes used on OTEC platforms, there is a need for an intensive training program specific to the hazards of the chemicals and processes. The process systems personnel must, as a matter of course, be well versed in these hazards as must the marine crew.

(b) Personnel Safety Equipment for Hazardous Chemicals - Due to the hazards to personnel by various chemicals proposed for use in OTEC plants, careful attention must be paid to training personnel and the selection and use of protective clothing and respiratory equipment. Therefore, the following requirements are presented:

- An oxygen emergency breathing system plumbed throughout OTEC platforms should be reconsidered in favor of an air system. Oxygen systems are expensive and are difficult to maintain. Additionally, oxygen in the presence of flammable chemicals (e.g., ammonia, fuel oils) is a severe explosive hazard. Instead of an oxygen system, the following approach will be used: A diver's low-pressure air system will be plumbed throughout OTEC platforms in the same manner as an oxygen system. Diver's air must be maintained at certain levels of purity. The air system will be tested daily for contaminants. The compressor intakes will be outboard or upwind of any possible sources of contamination (ammonia, chlorine, engine exhausts, etc.). If the platform is fixed, however, the location of fixed intakes may be a problem during a spill because the wind may shift. The air quality in a spill will be monitored. Large-volume tanks (air reservoir) will provide the necessary air volume for diving and recompression chamber operation, as well as emergency breathing purposes. This system must be dedicated to breathing air only and would require compressors separate from those required for plant or ship service (utility) air uses.
- Choice of emergency breathing devices will be regulated by U.S. Coast Guard Equipment Lists, 160.011 Gas Masks, Self-Contained Breathing Apparatus and Supplied-Air Respirators. Breathing equipment, air supplies, gas masks, etc., should be compatible with

those chemicals or hazardous situations encountered aboard the OTEC platform. Air breathing apparatus must be capable of connection to the diver's emergency breathing air system.

- Protective clothing must be worn when handling chemical contaminants on OTEC platforms. The Coast Guard reference above and OSHA 2206, Industry Safety, define protective apparel and equipment required.
- An emergency rescue team and plan must be developed to handle chemical casualties. This team will be capable of aiding personnel injured in chemical accidents and be capable of shutting down equipment in critical situations, such as chemical spills.

5.2.4 International Safety Concerns

The following institutional arrangements are briefly summarized from Knight et al. (1979) as they pertain to international regulatory law and safety.

5.2.4.1 Safety at Sea - The 1958 convention on the Law of the Seas creates obligations to address several safety subjects. The obligations have been documented through a series of International Conventions for Safety of Life at Sea (SOLAS). The most recent convention of SOLAS (1974) would require amendments applicable to OTEC.

5.2.4.2 Collision and Navigation - The Convention on International Regulations for the Prevention of Collisions at Sea (1972) describes the international rules of the road; however, it will require amendments for OTEC-related structures.

5.2.4.3 Construction/Design Standards - The International Loadline Convention (1966) is directed specifically to design and construction standards, and would have to be amended to apply to OTEC platforms.

5.2.4.4 Communications - The 1960 SOLAS convention requires cargo and passenger ships on the high seas to have radiotelegraph and radiotelephone devices. This convention will require an applicable OTEC amendment.

5.2.4.5 Other Safety Conventions - Generally the IMCO conventions which deal with safety and maintenance of the ocean environment appear to be expanding to apply to platforms and other structures which are not traditional vessels. To resolve this issue, further international and health and safety studies must be performed (IMCO, 1978).

Chapter 6

ALTERNATIVES

This Environmental Analysis is programmatic in scope, hence it encompasses alternatives within Ocean Thermal Energy Conversion technology. The alternatives include different design options which are currently projected as viable. The alternatives encompass four major areas:

- Power Cycle
- Platform Configuration
- Discharge
- Power Use

A matrix of alternatives is presented in Figure 6-1.

Geographic locations for OTEC are other alternatives but are not included in this programmatic and technological assessment.

6.1 POWER CYCLE

There are inherent environmental advantages and disadvantages which differ in open- and closed-cycle systems. Each system is subject to corrosion and erosion in the marine environment, which will cause release of trace elements. The OTEC power cycle will entrain and impinge members of the marine biota.

The open-cycle system uses ocean water as the working fluid and heat source, thereby eliminating leaks of ammonia or Freon™. Chlorine will be used for biofouling control in both the open- and closed-cycle. However, the open-cycle has less stringent biofouling control requirements and thereby requires smaller chlorine releases than the closed-cycle. The open-cycle system, on the other hand, requires the removal of non-condensable gases from the ocean waters. The removal of gases presents two problems: release of carbon dioxide and discharge of waters with low dissolved oxygen content. Fresh water may be produced by the open-cycle, resulting in the formation of a

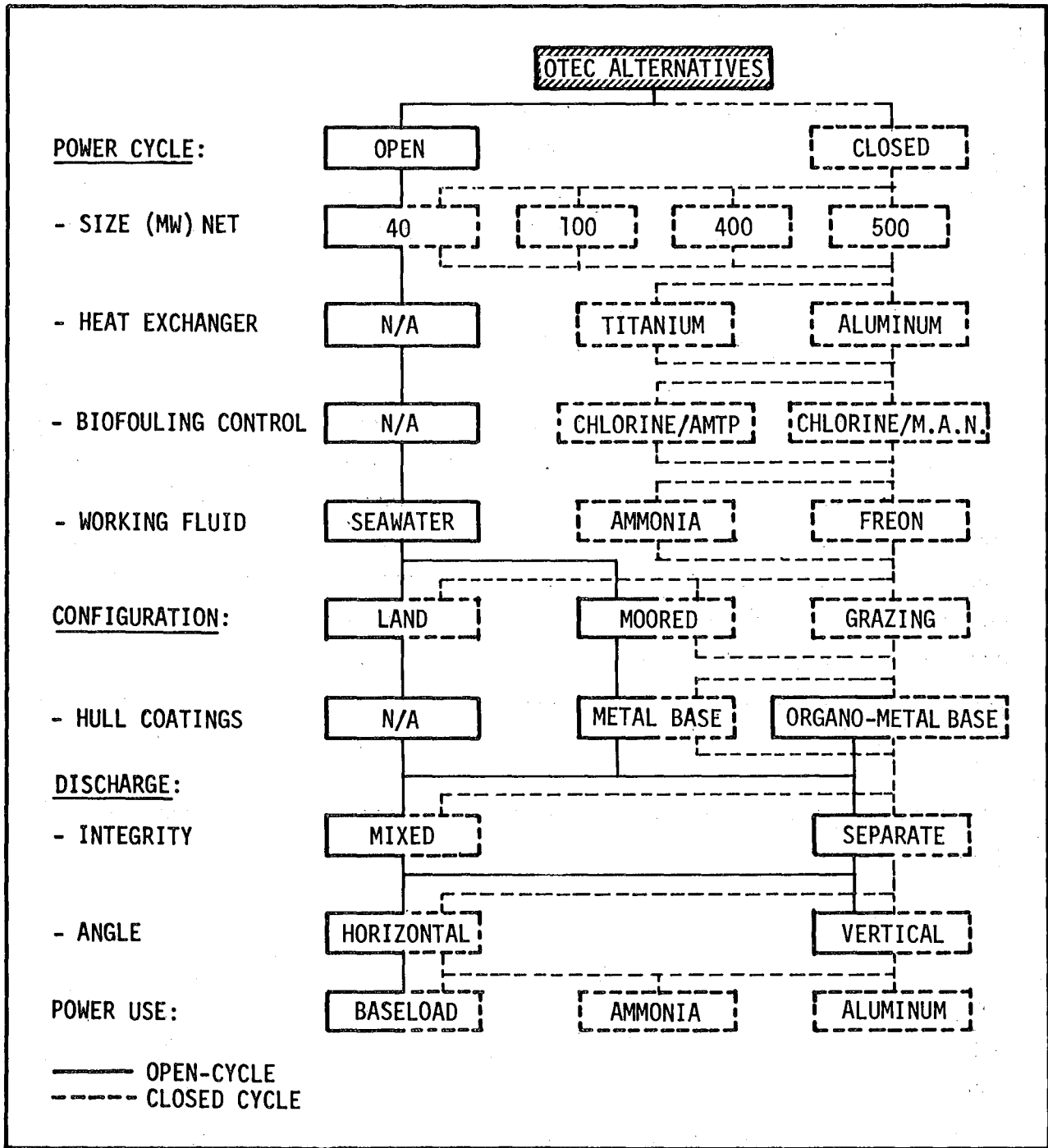

Figure 6-1. OTEC Alternatives

high salinity discharge. The open-cycle is generally applicable for smaller power modules, while the larger plants will utilize the closed-cycle.

6.2 PLATFORM CONFIGURATION

OTEC plants may be shore-based, moored offshore, or mobile floating plant-ship industrial facilities. Land-based plants are restricted as to location choice; the availability of a cold, deep ocean resource at minimal distance from shore is required, and relegates this type of plant to island communities.

Moored platforms may be located in water depths to approximately 2,150 m (7,000 ft); mooring technology is not adequate to hold OTEC-sized platforms at greater depths. It is difficult to moor platforms in ocean areas with irregular bottom topography. Another consideration with moored platforms is electrical transmission to shore. Electrical transmission is expensive and deep ocean transmission is not a well-practiced technology (Traut, 1979). Alternating current (AC), produced on OTEC platforms and transmitted through cables, cannot be efficiently transmitted over distances greater than 54 km; beyond 54 km a direct current (DC) converter would be required for the platform and the shore-based receiving point, thus further increasing electrical costs.

Plant-ships are intended to cruise the high seas beyond the jurisdiction of any coastal state.

6.3 DISCHARGE

Impact assessment of the discharge involves a variety of factors, among which are plume dilution and location after near-field mixing. The evaluation of these factors must not be passive, since plume geometry and dilution are governed by engineering criteria designed for convenience of construction. Plume geometry and dilution can be controlled, within specified limits, by proper design of discharge configurations. The design criteria include mixed and separate discharges, the velocity, angle, and depth of discharges, and the

number of discharge ports. It is not possible to consider a diffuser in the traditional sense, however the advantages of multiport discharges should be considered.

Warm and cold waters used to drive the OTEC power cycle may be mixed or released separately. The mixed discharges will dilute rich nutrient-laden deep ocean waters with nutrient-depleted surface waters. Mixed warm and cold water will produce effluents of less extreme temperature differences. Subsequently, the mixed discharge waters will tend to stabilize at deeper depths than warm water and at depths shallower than the cold water discharges.

In selection of horizontal or vertical releases, a choice must be made between larger dilutions which limit the vertical extent of the plume to the bottom of the mixed layer, or smaller dilutions which enable the discharge mix to be injected into the top of the thermocline. A deep descending plume decreases the possibility of reentrainment into the warm water intake and limits nutrient enrichment at the bottom of the photic zone. Conversely, the smaller dilutions associated with the deep descending plume cause higher biocide concentrations than with a more diluted plume.

6.4 POWER USE

Power generated by OTEC power cycles may be used for baseload electricity or the production of energy intensive products such as ammonia or aluminum. Selection of one use over the other must consider the industrial processes, natural resource reservoirs, and potential market locations. In addition, the open-cycle will produce fresh water as an operational byproduct.

Chapter 7

GLOSSARY, ABBREVIATIONS, AND REFERENCES

GLOSSARY

AESTHETICS	Pertaining to the natural beauty or attractiveness of an object or location.
AMBIENT	Pertaining to the existing conditions of the surrounding environment.
AMPHIDROMIC POINT	An area of the ocean where tidal effects vanish, due to 1) interference of two tidal waves or 2) the effect of the earth's rotation.
AMPHIPODS	A large group of minute, planktonic crustaceans with laterally compressed bodies.
ANTICYCLONIC	Rotation around a low pressure zone (winds) or around a warm core (ocean currents).
APPROPRIATE SENSITIVE MARINE ORGANISMS	At least one species representative of phytoplankton or zooplankton, crustacean or mollusk, and fish species chosen from among the most sensitive species documented in the scientific literature, or accepted by EPA as reliable control test organisms, to determine the anticipated impact of the wastes on the ecosystem at the disposal site.
ASSEMBLAGES	A group of organisms sharing a common habitat by chance.
ATHECATE	Lacking a supportive or protective external covering. Used in describing various groups, among them protozoans, rotifers, coelenterates, and molluscs.
ATMOSPHERE	A unit of pressure equal to the air pressure at mean sea level, comparable to a 760 mm column of mercury.
BACKGROUND LEVEL	The naturally-occurring level of a substance within an environment prior to the unnatural additions of that substance.
BAR SCREEN	Heavy gauge bars which prevent damage to static or traveling screens by large objects.
BASALT OUTCROPPINGS	An aphanitic crystalline rock of volcanic origin, composed largely of dark minerals, such as pyroxene and olivine.

BASELINE DATA	Data collected prior to the outset of actions which have potential of altering an existing environment.
BATHYMETRIC GRADIENT	The rate of change in depth of the bed of a body of water.
BATHYPELAGIC ZONE	The biogeographic realm of the ocean lying between depths of 1,000 and 4,000 m.
BEAUFORT SEA STATE	A system of estimating the visible effects of the wind on the sea surface. For example: Beaufort 6 (winds 22-27 knots) corresponds to "large waves beginning to form; white foam crests are extensive; some spray".
BENTHOS	A category of marine organisms which live on, in, or near the bottom of the ocean.
BIOACCUMULATE	The uptake and assimilation of substances, such as heavy metals, leading to a concentration of these substances within organism tissues, blood, or body fluids.
BIOCHEMICAL OXYGEN DEMAND (BOD)	The amount of dissolved oxygen used in a specified time period (usually 5 days) during the oxidation of oxygen-demanding material.
BIOASSAY	Exposure of a sample containing a test substance to an organism to determine the resulting response.
BIOCIDE	A substance which is capable of destroying living organisms.
BIOFOULING	The adhesion of sessile organisms to structures in contact with water.
BIOMAGNIFICATION	The process by which the concentration of a substance can be greatly increased when organisms in lower levels of a food chain are ingested by animals in upper levels.
BIOTA	Pertaining to life and living organisms, collectively plants and animals.
BIOTIC GROUPS	Organisms which are ecologically, structurally, or taxonomically grouped.
BIOGEOGRAPHIC	Geographic distribution of animal or plant life.

BIOMASS	The weight of living matter, including stored food, present in a population and expressed in terms of a given area of the water column or volume of habitat.
BLOOM	An enormous concentration of plankton in an area, caused either by sudden or gradual multiplications of organisms.
BLUE-GREEN ALGAE	Free-floating, single-celled or simple filamentous plants in which the blue color is imparted by a water-soluble accessory pigment.
BOREAL	Pertaining to the higher northern latitudes, as opposed to tropical and subtropical.
BOUSSINESQUE APPROXIMATION	The assumption that a fluid is incompressible, except that the thermal expansion produces a buoyancy.
CALANOID COPEPODS	Minute, planktonic copepods with the principal point of trunk articulation located between the thorax and abdomen. First antennae are long, at least half the length of the body. Second antennae have two branches.
CALCAREOUS	Consisting of or containing calcium carbonate.
CALCAREOUS OOZE	A fine-grained pelagic deposit which contains more than 30 percent calcium carbonate, derived from the skeletal material of various planktonic animals and plants.
CARBONATES	Salts or esters of carbonic acid.
CARBON FIXATION	Process by which primary producers (phytoplankton) absorb inorganic carbon for production of energy during photosynthesis.
CARIDEAN SHRIMP	Decapod crustaceans in the suborder Natantia, which includes the abundant and diverse shrimps and prawns.
CATCH RATE PER UNIT EFFORT	Unit used in commercial fisheries to describe the efficiency of equipment or the abundance of desired organisms in an area.
CATHODIC PROTECTION	Protecting a metal from electrochemical corrosion by using it as the cathode of a cell with a sacrificial anode.
CEPHALOPODS	A subgroup within the phylum mollusca. Typical members include the squid and the octopus.
CHAETOGNATHS	A phylum of small, elongate, transparent, wormlike invertebrates, known as arrow-worms, which are important carnivores in the zooplankton community. These planktonic organisms are abundant world-wide and occasionally multiply into vast swarms.

CHLORAMINE	Any of several chemical compounds containing nitrogen and chlorine.
CHLOROPHYLL	A group of green pigments which occur chiefly in intercellular bodies called chloroplasts, active in photosynthesis.
CHLOROPHYLL <u>a</u>	A pigment used in photosynthesis which serves as a convenient measure of phytoplankton biomass.
CILIATE PROTOZOANS	Microscopic, one-celled animals possessing cilia (hairlike processes of cells which beat rhythmically), used as locomotor or food acquiring structures. The majority of ciliates are solitary and free floating, but there are sessile and colonial forms.
CIRCULATION PATTERN	The general geometric configuration of oceanic currents usually applied in synoptic oceanography.
CIRRIPEDES	A subclass of the Crustacea, including barnacles and goose barnacles; individuals are planktonic in larval stages, but permanently fixed in the adult stage.
CLADOCERANS	Small, planktonic branchiopod crustaceans, commonly known as water fleas, characterized by a transparent bivalve shell.
CLOSED-CYCLE SYSTEM	A system in which the working fluid does not enter or leave the system, but is used repeatedly.
CLUPEID FISH	From Clupeidae, the herrings; a family of fishes, composing the most primitive group of higher bony fishes.
CLUSTER	Multiple OTEC plants.
COCCOLITHOPHORIDS	Microscopic, often abundant planktonic algae, the cells of which are surrounded by an envelope on which numerous small calcareous discs or rings (coccoliths) are embedded.
COELENTERATE	A predominantly-marine phylum of animals with specialized stinging cells and tentacles surrounding the mouth. Includes both attached (polyp) and planktonic (medusae) forms. Encompasses jellyfish and sea anemones.
COLD WATER PIPE	That component of the OTEC plant which extends down to approximately 1000 m in the sea, through which the cold water is drawn to condense the working fluid.

COMPENSATION DEPTH	The depth at which oxygen production by photosynthesis equals that consumed by plant respiration during a 24 hour period.
CONDENSERS	The portion of heat exchangers which conducts heat from the gaseous working fluid to the cold water drawn from the cold water pipe. In this process the vapor is changed or "condensed" from a gas to a liquid.
CONTINENTAL MARGIN	Zone separating the emergent continents from the deep sea floor; generally consists of the Continental Shelf, Continental Slope, and Continental Rise.
CONTINENTAL SHELF	The zone bordering a continent extending from the line of permanent immersion to the depth (usually about 180 m) where there is a rather steep descent toward the great depths.
CONTINENTAL SLOPE	A declivity from the outer edge of a continental shelf, extending from the break in slope to the deep sea floor.
COPEPOD	Minute, planktonic crustaceans, mostly between 0.5 and 10 mm in length. These shrimplike crustaceans are abundant worldwide and are an important link in the oceanic food chain.
COPEPODID STAGES	Copepod larvae which have passed through the naupliar stage, but have not reached the adult stage.
CORROSION	The gradual erosion of a surface, especially by chemical means.
COSMOPOLITAN	Having a worldwide distribution wherever the habitat is suitable, with reference to the geographic distribution of taxon.
CRUSTACEANS	Animals with jointed appendages and a segmented external skeleton composed of a hard shell or crust. The group includes barnacles, crabs, shrimps, and lobsters.
CTENOPHORES	Spherical, pear-shaped, or cylindrical animals of jelly-like consistency ranging from less than 2 cm to about 1 m in length. The outer surface of the body bears 8 rows of comblike structures. These planktonic organisms are commonly called comb jellies or sea walnuts.
CURRENT DROGUE	Device placed somewhere in the water column which moves with the current, measuring the average current velocity.

CURRENT METER	Any device for measuring and indicating speed and direction of flowing water.
CURRENT SHEAR	The measure of the spatial <u>rate of</u> change of current velocity with units of cm-sec ⁻¹ m ⁻¹ .
CYCLONIC EDDIES	Mesoscale (50-100 km) features of oceanic circulation in which water flows in a circular pattern around cold core waters.
CYCLOPOID COPEPODS	An order of Copepoda. These abundant, minute crustaceans have wide abdomens and linear bodies.
DECAPOD	The largest order of Crustaceans, such as the crab, lobster, or shrimp, with five pairs of locomotor appendages, each joined to a segment of the thorax.
DELTA t	Difference in temperature between ocean depths.
DEMERSAL	Living on or near the bottom of the sea.
DENSITY	The mass per unit volume of a substance.
DETRITIVORES	An organism which ingests detritus.
DETRITUS	Loose material (organic or inorganic) which results directly from disintegration.
DIATOM	A minute, free-floating algae with an external skeleton of silica, abundant world wide.
DIEL CYCLE	Pertaining to, or occurring within a 24-hour cycle.
DIEL MIGRATION	The cyclic pattern of vertical migration which occurs with a 24-hour period. Usually, organisms which display this pattern migrate toward the surface during the night and away from the surface during the day.
DIFFUSER	The section of discharge pipe which is modified, usually through the addition of numerous ports or holes, to promote rapid mixing of the discharge with the ambient waters.
DIFFUSION	Transfer of material (e.g., salt) or a property (e.g., temperature) by eddies or molecular movement. Diffusion causes dissemination of matter under the influence of a concentration gradient, with movement from the stronger to the weaker solution.
DILUTION	A reduction in concentration through the addition of ambient waters.

DINOFLAGELLATES	Microscopic, planktonic organisms, which may possess characteristics of both plants (photosynthesis) and animals (ingestion of food); abundant world-wide.
DISCHARGE MOMENTUM	A physical quantity which is the product of the discharge mass and its velocity.
DISCHARGE PLUME	The fluid volume derived from the discharge pipe which is distinguishable from the surrounding water.
DISPERSION	Dissemination of discharged water over large areas by the natural processes of ocean turbulence and ocean currents.
DISPLACEMENT VOLUME	The volume of water which is displaced by a sample of organisms; a measure of biomass.
DISSOLVED OXYGEN	Amount of oxygen dissolved in a unit volume of water; usually expressed in ml/liter at standard temperature and pressure.
DISSOLVED SOLIDS	The dissipation of solid matter in solution, e.g., salt dissolved in water.
DIVERSITY	A measure of the variety of species in a community which takes into account the relative abundance of each species.
DOLIOLIDS	Transparent, planktonic invertebrates in the class Thaliacea, either partly or wholly ringed by muscular bands.
DOMINANT SPECIES	A species or group of species which largely control the energy flow and strongly affect the environment within a community.
DOWNWELLING	Downward movement of water, usually associated with a convergent zone.
DRY WEIGHT	The weight of a sample of organisms after the water has been removed; a measure of biomass.
DYNAMIC POSITIONING	A method by which a vessel maintains position at sea without anchors; achieved by means of thrusters placed at various positions along the hull.
EASTROPAC	Eastern Tropical Pacific (Program).
ECHINODERMS	Principally benthic marine animals having calcareous plates with projecting spines forming a rigid or articulated skeleton or plates and spines embedded in the skin. These organisms have a radically symmetrical, usually five-rayed, body and include the sea starfish, sea urchins, crinoids, and sea-cucumbers.

ECONOMIC RESOURCE ZONE (ERZ)	The ocean zone within 200 nautical miles from shore in which the adjacent coastal state possesses exclusive rights to the living and non-living ocean resources.
ECOSYSTEM	An ecological community together with its physical environment, considered as a unit, each influencing the properties of the other, and each necessary to the maintenance of life.
EDDY	A current of water moving contrary to the direction of the main current, especially in a circular motion.
ENHANCED HEAT EXCHANGER	Heat exchanger with increased surface area, either by addition of fins or surface coating.
ENDEMIC	Restricted or peculiar to a locality or region.
ENTHALPY	Thermodynamic function of a system equal to the internal energy plus the product of the pressure and volume.
ENTRAINMENT	(1) The process by which organisms are drawn into the intake pipes of OTEC; (2) the process by which ambient waters are mixed with the discharge plume.
EPIFAUNA	Animals which live on or near the bottom of the sea.
EPIPELAGIC	Ocean zone ranging from the surface to 200 m in depth.
EROSION	The group of natural processes including weathering, dissolution, abrasion, and corrosion by which the surface is removed from a metal.
ESTUARY	A semienclosed, tidal, coastal body of saline water with free connection to the sea, commonly the lower end of a river.
EUPHAUSIIDS	Shrimp-like, planktonic crustaceans, commonly called krill, widely distributed in oceanic waters. These organisms grow to 8 cm in length and are important links in the oceanic food chain.
EVAPORATOR	The chamber in which the working fluid is vaporized to a gas prior to passing through the turbine.
EXTINCTION COEFFICIENT	A measure of the attenuation of downward-directed light.
FAR-FIELD	A somewhat arbitrary cutoff point between regions, where the mixing of discharge is governed by the discharge momentum, and the region where natural ocean turbulence becomes the dominant factor in further mixing of the discharge waters.

FAUNA	The animal population of a particular location, region, or period.
FLOCCULATE	The process of precipitated aggregation into small lumps, especially with regard to solids and colloids.
FLORA	The plant population of a particular location, region, or period.
FORAMINIFERA	Single-celled, planktonic protozoans possessing shells, usually of calcium carbonate.
GALVANIC CORROSION	The corrosion, above normal corrosion of a metal, associated with the flow of electric current to a less active metal in the same solution and in contact with the more active metal.
GASTROPODS	Molluscs which possess a distinct head, generally with eyes and tentacles, and a broad, flat foot, and which are usually enclosed in a spiral shell.
GELATINOUS ORGANISMS	A general term used to describe the large organisms composed of a jelly-like substance, including the cnidarians, salps, siphonores, and ctenophores; jellyfish.
GEOMAGNETIC ELECTROKINETOGRAPH (GEK)	A shipboard surface-current measuring device designed to record the electrical potentials developed by the movement of an electrolyte (ocean water) through a magnetic field (the earth's) in depths greater than 100 fathoms.
HARPACTICIDS	An order of minute copepod crustaceans of variable forms, generally linear and more or less cylindrical.
HEAT EXCHANGER	A material (usually metal) with a high coefficient of thermal conductance which is used to exchange heat between the working fluid and the heat source or sink.
HEAVY METALS OR ELEMENTS	Elements which possess a specific gravity of 5.0 or greater.
HERBIVOROUS	Eating or feeding on plants.
HETEROPOD	A planktonic group of small gastropods which possess a minute shell and a foot which has been modified into a swimming organ.
HOLOPLANKTONIC	Organisms which spend their complete life cycle in a floating state.

HYPERIID AMPHIPOD	A suborder of crustaceans; these planktonic organisms are distinguished by large eyes which nearly cover the entire head.
ICHTHYOPLANKTON	Fish eggs and weakly motile fish larvae.
IMPINGEMENT	A situation in which an organism is forced against a barrier, such as an intake screen, as a result of the intake of water into a facility, such as a power plant.
INDICATOR SPECIES	A species of marine plankton characteristically present in a certain water mass to which it is restricted, so that, with proper precautions, its presence can be taken as an indication of the presence of water of that origin. Species of medusae, chaetognaths, euphausiids, pteropods, and tunicates are often used as indicator species.
INDIGENOUS	Having originated in and being produced, growing, or living naturally in a particular region or environment.
INFAUNA	Animals which live buried in soft substrata.
INITIAL MIXING	That dispersion or diffusion of liquid, suspended particulate, and solid phases of a material which occurs within 4 hours after dumping.
IN SITU	In the natural or original position; pertaining to samples analyzed directly in the environment.
INSULAR SHELF	The zone surrounding an island extending from the line of permanent immersion to the depth (usually 100 fathoms) where there is a marked or rather steep descent towards the great depths.
INVERTEBRATES	Animals without backbones.
IRRADIANCE	The radiant flux incident on an area per unit area.
ISLAND MASS EFFECT	A phenomenon in which the abundance or biomass of organisms in the immediate vicinity of an island is markedly higher than in the surrounding oceanic area.
ISOPODS	The second largest order of crustaceans. These flattened, planktonic organisms are generally scavengers.

K_s

The dissociation constant of the enzyme-substrate complex in an enzyme-activated reaction. Used in biochemistry, especially metabolic studies and photosynthesis, to study the effects of changes in concentration of reactants and products on organisms. It is measured as:

$$K_s = \frac{[E][S]}{[ES]}$$

where: [E] = concentration of enzyme
[S] = concentration of substrate
[ES] = concentration of enzyme-substrate complex.

KILOPASCAL (kPa)

One thousand pascals. A pascal is a unit of pressure equal to the pressure resulting from a force of one newton acting uniformly over an area of one square meter.

LAMILLIBRANCHS

Any of the molluscs of the class Lammellibranchia having a hinged bivalve shell, including clams, mussels, and oysters.

LANGLEY

A unit of energy per unit area commonly employed in radiation theory; equal to 1 gram calorie per square centimeter.

LARVACEANS

Minute, transparent, planktonic animal having a globular or cylindrical shape, many of which are covered by a tough, flexible material. A tail is present and the body has a U-shape.

LC₅₀

A bioassay, or toxicity study, in which the concentration of pollutant which causes 50 percent mortality in the population of test organisms during a unit time is determined.

LITHOGENIC

Of or derived from rock.

MACROZOOPLANKTON

Planktonic organisms with lengths between 200 and 2000 microns, composed mainly of copepods, chaetognaths, and larval forms.

MAFLA

An acronym composed of Mississippi, Alabama and Florida. The acronym was adopted to identify a series of oceanographic surveys which took place off the coasts of the above named states in the Gulf of Mexico.

M.A.N. BRUSHES

Brushes which travel through heat exchanger tubes for removal of microbial slime.

MARINE

Pertaining to the sea.

MEDUSAE	Commonly called jellyfish; any of various free-floating animals possessing two cell layers, a digestive cavity with only one opening, and a disk or bell-shaped body of jelly-like consistency. Many have long tentacles with stinging cells.
MEGAWATT (MW)	One million watts. A watt is a unit of power. It is the amount of work done per unit time and is equal to one joule/sec. One horsepower is equal to 746 watts.
MEROPLANKTON	Organisms which spend only a portion of their life cycle as plankton; usually composed of floating developmental stages (i.e., eggs and larvae) of the benthos and nekton organisms. Also known as temporary plankton.
MESOPELAGIC	Relating to the oceanic depths between 200 m to 1,000 m.
MICROFLAGELLATES	Protozoans which possess flagella as adult locomotor organelles; generally considered to be the most primitive of the protozoans.
MICROGRAM-ATOM (ug-at)	Mass of an element in micrograms, divided by its atomic weight.
MICRO-MOLE (u mole)	A measure of mass, equal to 6.02×10^{23} (Avogadro's number) atoms (of an element) or molecules, divided by 10^6 .
MICROMOLLUSKS	Tiny mollusks generally less than 0.5 mm in size.
MICRONEKTON	Organisms commonly collected in an Isaac-Kidd Midwater Trawl. This group consists of weak-swimming nekton such as mesopelagic fish, small squid, gelatinous organisms, and fish larvae.
MICRONUTRIENTS	Substance which an organism must obtain from its environment to maintain health, though necessary only in minute amounts.
MICROORGANISMS	Microscopic organisms, including bacteria, protozoans, yeast, viruses, and algae.
MICROZOOPLANKTON	Planktonic animals with lengths between 20 and 200 microns, composed mainly of protozoans and juvenile copepods.
MIXED LAYER	The upper layer of the ocean which is well mixed by wind and wave activity. Within this layer temperature, salinity, and nutrient concentration values are essentially homogeneous with depth.

MOLE	A measure of mass, equal to 6.02×10^{23} (Avogadro's number) atoms (of an element) or molecules.
MONEL	A corrosion-resistant alloy of nickel, copper, iron, and manganese.
MONITORING	As considered herein, the observation of environmental effects of disposal operations through biological and chemical data collection and analyses.
MOON POOL	An opening in the hull of a vessel through which equipment or structures may be conveniently deployed.
MOTILE	Exhibiting or capable of spontaneous movement.
MYCTOPHIDS	Commonly called lantern fish; this family of mesopelagic fish are typically 7-15 cm in length, possess neatly arranged photophores along the sides, and undergo large-scale diel migrations.
MYSIDS (Mysidae)	Elongate shrimp-like crustaceans which generally inhabit deep waters and are nearly transparent.
NANNOPLANKTON	Minute planktonic plants and animals which are 50 microns or less in size and include algae, bacteria and protozoans. Individuals of this size will pass through most nets and are usually collected in centrifuges.
NAUPLIAR STAGES	A larval stage characteristic of many groups of Crustacea; the oval, unsegmented body has three pairs of appendages: uniramous antennules, biramous antennae, and mandibles.
NEAR-FIELD	The near-field region is that region in which the plume momentum is the dominant factor, controlling entrainment and mixing of the plume with the ambient receiving waters.
NEKTON	Free-swimming aquatic animals, essentially moving independent of water movements.
NERITIC WATERS	Shallow waters in the marine environment.
NET POSITIVE SUCTION HEAT (NPSH)	An engineering term used to describe the height of seawater which can be drawn up a pipe by a pump. The units are pounds per square inch.
NEUSTON	A community of minute organisms which are associated with the surface layer of water.
NUTRICLINE	The region of the water column where the nutrient concentration changes most rapidly with depth.

NUTRIENT	Any substance which promotes growth or provides energy for biological processes.
NUTRIENT-LIGHT REGIME	The overall condition of the nutrients and light in the environment in relation to photosynthesis.
ONE PERCENT LIGHT DEPTH	The depth at which light has been attenuated to 1 percent of its surface value; used to define the photic zone; that depth above which net productivity of phytoplankton may occur.
OPEN CYCLE SYSTEM	A power plant system in which the coolant and/or working fluid passes through the plant only once and then discharged.
OPERATING CONDITIONS	The maximum value of winds, waves, or currents below which OTEC-1 is able to operate.
ORNITHOLOGICAL	Dealing with the study of birds.
ORTHO-PHOSPHATE	One of the possible salts of orthophosphoric acid; one of the components in seawater of fundamental importance to the growth of marine phytoplankton.
OSTRACODS	A subclass of the class Crustacea containing small, bivalved aquatic forms; the body is unsegmented and there is no true abdominal region.
OTEC	<u>O</u> cean <u>T</u> hermal <u>E</u> nergy <u>C</u> onversion.
OTEC-1	The proposed 1 megawatt test platform which will test the ocean thermal energy conversion concept.
OXIDATION	The combination of a substance with oxygen. A reaction in which the atoms in an element lose electrons and its valence is correspondingly increased. Examples of oxidation are the rusting of iron, the burning of wood in air, the change from cider to vinegar, and the decay of animal and plant material.
OXYGEN MINIMUM LAYER	The portion of the water column in which the lowest concentration of dissolved oxygen exists.
PARAMETERS	Any of a set of arbitrary physical properties whose values determine the characteristics or behavior of something, e.g., temperature, pressure and density; a characteristic element.
PARTICULATE CARBON	Finely divided solid particles of carbon suspended in the water column.

PARTS PER THOUSAND (ppt, ‰)	A unit of concentration of a mixture which denotes the number of parts of a constituent contained per thousand parts of the entire mixture. For example, the average salinity of sea water is usually reported to be 35 ‰ indicating 35 parts total salts per 1000 parts seawater (including the salts).
PELAGIC	Pertaining to the open sea or organisms not associated with the bottom.
PENAEID SHRIMP	A group of crustaceans which live on sand bottoms in shallow water; important to commercial fisheries.
pH	The acidity or alkalinity of a solution as determined by the negative logarithm of the hydrogen ion concentration.
PHOTIC ZONE	The layer of the ocean from the surface to the depth where light has been attenuated to 1.0 percent of the surface value. The zone in which primary production shows a net increase.
PHOTOSYNTHESIS	Synthesis of chemical compounds in light, especially the manufacture of organic compounds from carbon dioxide and a hydrogen source, with simultaneous liberation of oxygen by chlorophyll-containing plant cells.
PHYTOPLANKTON	Minute passively floating plant life of a body of water; the base of the food chain in the sea.
PLANKTON	Organisms whose movements are determined by the currents and not by their own locomotive abilities.
PLEUSTON	Organisms whose bodies are situated partly in the water and partly in the air; typical representatives include the portugese man-of-war (<u>Physalia</u>), the by-the-wind-sailor (<u>Velella</u>), and the marine water strider (<u>Halobates</u>); Pleuston is from the Greek, meaning "a sailor".
POLYCHAETES	The largest class of the phylum Annelida, (segmented worms) distinguished by paired, lateral, fleshy appendages provided with setae, on most segments.
PRIMARY PRODUCTION	The amount of organic matter synthesized by organisms from inorganic substances in unit time, in a unit volume of water, or in a column of water of unit area extending from the surface to the bottom.
PROSOBRANCH VELIGERS	Minute, planktonic larval stage of a subclass of gastropod molluscs. Prosobranchs encompass most shelled marine gastropods, consequently are distributed world-wide.

PROTOZOAN	Single-celled, microscopic organisms which includes the most primitive forms of animal life.
PTEROPODS	The sea butterflies, an order of pelagic gastropod molluscs in the subclass Opisthobranchia, in which the foot is modified into a pair of large fins and the shell, when present, is thin and glasslike.
RADIOLARIANS	A subclass of protozoans whose members are noted for their siliceous skeletons and characterized by a membranous capsule which separates the outer from the inner cytoplasm.
REACTIVITY	The tendency of a substance to combine (react) with another substance.
RECRUITMENT	Addition to a population by reproduction of new individuals.
RED TIDE	A red or reddish-brown discoloration of surface waters most frequently in coastal regions, caused by concentrations of dinoflagellates.
REFERENCE OR AFFECTED WATER COLUMN	The volume of water which may be potentially affected by OTEC each day.
R_f	The thermal resistance to biofouling. A number which quantifies the increase in the resistance to the flow of heat across the heat exchangers caused by the presence of microbial slime. The reciprocal of thermal conductance. The units of R_f are (10^{-2} hr m ² °K W ⁻¹).
SALINITY	The amount of dissolved salts in seawater measured in grams per kilogram, or parts per thousand.
SALP	Planktonic chordates with translucent, somewhat flattened, keg-like bodies, common in warm seas. These organisms often form chains, and are sexual and asexual, the former budding the latter.
SARCODINE PROTOZOANS	A superclass of Protozoa in which movement involves protoplasmic flow.
SCYPHOMEDUSAE	The cnidarian most frequently called jellyfish, having a bell diameter of 2 to 40 cm, and represented by the sea nettle and the sea wasp.
SEA STATE	Numerical or written description of ocean surface roughness. For more precise usage, sea state may be defined as the average height of the highest one-third of the waves observed in a wave train referred to a numerical code which covers an increasing range of such heights.

SIGNIFICANT WAVE HEIGHT	The average height of the one-third highest waves of a given wave group.
SILICOFLAGELLATES	An order of star-shaped flagellate algae having an internal, siliceous, skeletal network, numerous yellow chromatophores, and a single flagellum.
SIPHONOPHORE	An order of planktonic colonial, marine coelenterates, often called jellyfish, which includes the portugese man-of-war.
SPAR BUOY RISER	An independently-moored, retrievable pipe which is buoyant, allowing connection to the mother ship.
SPECIES	(1) A group of organisms having similar characteristics and capable of interbreeding and producing viable offspring; (2) A taxon forming basic taxonomic groups which closely resemble each other structurally and physiologically and in nature, interbreed and produce fertile offspring.
SPECIFIC GRAVITY	The ratio of the density of substance relative to the density of pure water at 4°C.
STANDING STOCK	The biomass or abundance of living material per unit volume or area of water.
STATIC SCREENS	Intake screens which are fixed in position.
STERNOPTYCHIDS	Commonly called hatchet fish, these small (less than 8 cm) mesopelagic fish have photophores along the lateral margins of the underside of the body, are distributed world-wide, and undergo large-scale diel migrations.
STRESSED	A state caused by factors which tend to alter an existent equilibrium, or normal state.
SURVEILLANCE	Systematic observation of an area by visual, electronic, photographic, or other means for the purpose of ensuring compliance with applicable laws, regulations and permits.
SURVIVAL CONDITIONS	The maximum intensity of winds, waves and currents which a structure must endure without sustaining permanent damage.
SUSPENDED SOLIDS	Finely divided particles of a solid temporarily suspended in a liquid, such as soil particles in water, expressed as a weight per unit volume.

SYSTEM INTEGRATION CONTRACTOR (SIC)	The DOE designated company, selected through the process of competitive procurement, which will provide complete management and services for the design, conversion, fabrication/construction, delivery, deployment, operation, and support of the ocean platform to be used for OTEC-1 testing.
TAXA	Two or more of a hierarchy of levels, in the biological classification of organisms, which best reflect the totality of similarities and differences.
TEMPORAL DISTRIBUTION	The geographical range of an organism over time.
TERRIGENOUS	Being or relating to oceanic sediment derived directly from the destruction of rocks on the earth's surface.
THERMAL EFFICIENCY	The ratio of the work done by a heat engine to the heat energy absorbed by it.
THERMAL SHOCK	The process of changing the ambient temperature faster than organisms can adjust to the change; used to clean biofouled areas.
THERMOCLINE	The region of the water column where temperature changes most rapidly with depth.
TINTINNIDS	Microscopic, planktonic protozoans which possess a tubular or vase-shaped outer shell.
TOTAL DISCHARGE HEAD	An engineering term which describes the force provided by a pump; equal to the height of seawater which can be supported by the pump. The units are pounds per square inch.
TOTAL RESIDUAL CHLORINE (TRC)	The summation of the chlorine concentrations in various compounds in water, including hypochlorous acid, hypochlorite ion, chloramines, and other chloro-derivatives.
TOXICITY STUDY	The addition of a specific pollutant to a sample of natural waters containing a number of test organisms.
TRACE CONSTITUENT	An element or compound found in the environment in extremely small quantities.
TRADE WINDS	The wind system which occupies most of the tropics and blows from the subtropical highs towards the equatorial trough; the winds are northeasterly in the northern hemisphere and southeasterly in the southern hemisphere.
TRAVELING SCREEN	Screens attached in belts which can be continuously changed.

TROPHIC LEVELS	Any of the feeding levels through which the passage of energy of an ecosystem proceeds. Typical marine trophic levels include: phytoplankton, zooplankton, fish.
TROPICAL CYCLONE	A type of atmospheric disturbance, originating between 25° north and south latitudes, characterized by masses of air rapidly circulating clockwise in the southern and counterclockwise in the northern hemisphere, about a low-pressure center. Tropical cyclones are usually accompanied by stormy, often destructive weather.
TUNICATES	A subphylum of small, planktonic marine chordate animals with clefts in the vascular walls of the pharyngeal gills, a thick secreted covering layer, a greatly reduced nervous system, and a heart able to reverse the direction of blood flow by changes of its contractions.
TURBIDITY	A reduction in transparency, as in the case of seawater, by suspended sediments or plankton.
TURNOVER RATE	The time necessary to completely replace the standing stock of a population; generation time.
UPWELLING	The rising of water toward the surface from subsurface layers of a body of water. Upwelling is most prominent where persistent wind blows parallel to a coastline so that the resultant wind current sets away from the coast. The upwelled water, besides being cooler, is rich in nutrients, so that regions of upwelling are generally areas of rich fisheries.
VELOCITY CAP	Restriction plate placed over intake ports to change direction of inflow.
VERTICAL DISTRIBUTION	The frequency of occurrence over an area in the vertical plane.
WARM WATER PIPE	That component of the OTEC plant through which the warm, surface water used to vaporize the working fluid is drawn.
WATER MASS	A body of water usually identified by its temperature-salinity (T-S) curve or its chemical content.
WEST WIND DRIFT	The ocean current with the largest volume transport and the swiftest current; it flows from west to east through all the oceans around the Antarctic Continent.
WET WEIGHT	The weight of a sample of organisms determined before the interstitial water is removed.

WORKING FLUID

The medium in an OTEC plant which is vaporized by warm ocean water, passed over a turbine to generate electricity, and finally condensed by cool ocean water to be recirculated through the closed system.

ZOOPLANKTON

The passively floating or weakly swimming animals of an aquatic ecosystem.

ABBREVIATIONS

ANOVA	Analysis of Variance
As	Arsenic
BOD ₅	biochemical oxygen demand
CE	U.S. Army Corps of Engineers
CFR	Code of Federal Regulations
CZMA	Coastal Zone Management Act
cm	centimeter(s)
cm/sec	centimeters per second
COD	chemical oxygen demand
Cu	Copper
°C	degrees Celsius
DOC	United States Department of Commerce
DOE	United States Department of Energy
DPA	Deepwater Port Act
DMRP	Dredged Material Research Program
EA	environmental assessment
EIS	environmental impact statement
EPA	U.S. Environmental Protection Agency
ERZ	Economic Resource Zone
FWPCA	Federal Water Pollution Control Act
GW	gigawatts (10 ⁹ watts)
Hg	Mercury
ICNT	Informal Composite Negotiating Text
IMCO	Inter-governmental Maritime Consultative Organization
ISA	International Seabed Authority
kg	kilogram(s)
kg/day	kilograms per day
kg/hr	kilograms per hour
km	kilometer(s)
kph	kilometers per hour
MPRSA	Marine Protection, Research, and Sanctuaries Act
m	meter(s)
m ²	square meter(s)
m ³	cubic meter(s)

m sec ⁻¹	meters per second
µg-atom N liter ⁻¹	microgram atom of nitrogen per liter
µg kg ⁻¹	micrograms per kilogram, or millionth gram per kilogram
µg liter ⁻¹	micrograms per liter, or millionth gram per liter
µ	micrometer(s) = 0.001 millimeter
mi	mile(s)
mg C	milligrams carbon
mg	milligram(s), or thousandth gram
mg kg ⁻¹	milligrams per kilogram
mg kg ⁻¹ dw	milligrams per kilogram dry weight
ml	milliliter(s), or thousandth liter
mm	millimeter(s), or thousandth meter
MW	megawatts
NEPA	National Environmental Policy Act
ng liter ⁻¹	nanograms per liter, billionth gram per kilogram
NPDES	National Pollution Discharge Elimination System
nmi	nautical mile(s)
nmi ²	square nautical miles
NOAA	National Oceanic and Atmospheric Administration
NTU	nephelometric turbidity units
OCS	Outer Continental Shelf
OSHA	Occupational Safety and Health Administration
OTEC	Ocean Thermal Energy Conversion
ppm	parts per million
ppt	parts per thousand
psia	pounds per square inch absolute
SAR	Safety Analysis Report
sec	second(s)
sq	square
SS	suspended solids
S-T-D	salinity-temperature-depth test
TKN	total Kjeldahl nitrogen
TOC	total organic carbon
TSS	total suspended solids
U.S. AED	U.S. Army Engineer District
USCG	U.S. Coast Guard

U.S. DOE

USGS

XBT

yd³

Zn

U.S. Department of Energy

U.S. Geological Survey

expendable bathythermograph

cubic yard(s)

Zinc

REFERENCES

- Ackefors, H., and E. Zillioux. 1975. Preliminary report on the biology of Undinula vulgaris (Dana) and Calanus minor (Dana) in the area Florida Current-Caribbean Sea. Unpublished manuscript. Inst. of Mar. Res., Lysekil, Sweden. Meddland.
- Adams, E.E., D.J. Fry, and D.M. Coxe. 1979. Results of a near-field physical model study. In G.L. Dugger, Ed., Preprints Volume II of the Sixth Ocean Thermal Energy Conversion Conference. June 19-22, 1979. Washington D.C.
- Adams, J.R. 1969. Ecological investigations around some thermal power stations in California tidal waters. Chesapeake Sci. 10:145-154.
- Amesbury, S.S. 1975. The vertical structure of the midwater fish community off leeward Oahu, Hawaii. Ph.D. Thesis. University of Hawaii. 106 pp.
- Araga, C., and H. Tanase. 1968. Further record of winter fish stranding in the vicinity of Seto. Pub. Seto Mar. Biol. Lab. 16:207-218.
- Arsen'ev, V.S., L.I. Galerkin, E.A. Plakhin, and V.V. Sapozhnikov. 1971. Major hydrological and hydrochemical features of the region investigated during the 44th cruise of the VITYAZ. In Vinogradov, M.E. ed.
- Atwood, D.K., P. Duncan, M.C. Stalcup, and M.I. Barcelona. 1976. Ocean thermal energy conversion: resource assessment and environmental impact for proposed Puerto Rico site. Final Report NSF Grant AER 75-00145. NOAA/AOML. Miami, FL. 104 pp.
- Austin, H.M. 1971. The characteristics and relationships between the calculated geostrophic current component and selected indicator organisms in the Gulf of Mexico Loop Current system. Ph.D. Thesis, Florida State University, College of Arts and Sciences. 369 pp.
- Backus, R.H., J.E. Craddock, R.L.H., and D.L. Shores. 1970. The distribution of mesopelagic fishes in the equatorial and western north Atlantic Ocean. Journal of Marine Research. 28(2):179-201.
- Balazs, G.H. 1976. Green turtle migrations in the Hawaiian Archipelago. Biol. Conserv., (9):125-140.
- Balech, E. 1967. Microplankton of the Gulf of Mexico and Caribbean Sea. Texas A&M Res. Found. 67-10-T. College Station, TX. 144 pp.
- Barnett, T.P. 1978. Ocean temperatures: precursors of climate change, Oceanus, 21(4):27-32.
- Bartone, L.M. 1978. Alternative power systems for extracting energy from the ocean: a comparison of three concepts. Pages VII 68-VIII 108. In: A. Lavi (Ed.), Proceedings of the Fifth OTEC Conference. U.S. Dept. of Energy. CONF-780236.

- Bary, B.M. 1970. Biogeography and ecology of plankton in the south Pacific. Pages 211-225 in W.S. Wooster, ed., Scientific exploration of the south Pacific, Natl. Acad. Sci., Wash. D.C.
- Bathen, K.H. 1977. An evaluation of oceanographic and socio-economic aspects of a nearshore ocean thermal energy conversion pilot plant in subtropical Hawaiian waters. National Science Foundation, Energy Res. and Dev. Admin. n.p.
- Bathen, K.H. 1975. A further evaluation of oceanographic conditions found off Keahole Point, Hawaii, and the environmental impact of nearshore ocean thermal energy conversion plants on subtropical Hawaiian waters. Department of Planning and Economics, University of Hawaii. 77 pp.
- Beers, J.R. 1978. Personal communication. Institute of Marine Resources, University of California, San Diego; La Jolla, CA.
- Beers, J.R. and G.I. Stewart. 1969. Micro-zooplankton and its abundance relative to the larger zooplankton and other seston components. Mar. Biology. 4:182-189.
- Beers, J.R. and G.L. Stewart. 1971. Microzooplankton in the plankton communities of the upper waters of the eastern tropical Pacific. Deep-Sea Research. 18:861-883.
- Beers, J.R., D.M. Steven, and J.B. Lewis. 1968. Primary productivity in the Caribbean Sea off Jamaica and the tropical north Atlantic off Barbados. Bull. Mar. Sci. 18:86-104.
- Bell, K.J. 1977. The effect of fouling upon OTEC heat exchanger design, construction and operation. Oklahoma University, Stillwater, OK. 34 pp.
- Belyayeva, T.V. 1972. Quantitative distribution of planktonic diatoms in the western part of the tropical Pacific. Oceanology 11(4):578-585.
- Berndt, T. and J.W. Connell. 1978. Plate heat exchangers for OTEC. In A. Lavi and T.N. Veziroglu, eds., Proceedings of the Fifth Ocean Thermal Energy Conversion Conference, February 20-22, 1978. U.S. Dept. of Energy. CONF-780236. Sept. 1978. (3) VI:261-287.
- Blackburn, M. 1979. Personal communication. Friday Harbor, WA.
- Blackburn, M. 1968. Micronekton of the eastern tropical Pacific Ocean: family composition, distribution, abundance, and relations to tuna. Fishery Bulletin. 67(1):71-115.
- Blackburn, M., R.M. Laurs, R.W. Owen, and B. Zeitzschel. 1970. Seasonal and areal changes in standing stocks of phytoplankton and micronekton in the eastern tropical Pacific. Mar. Biol. 7:14-31.
- Blackburn, M. and F. Williams. 1975. Distribution and ecology of skipjack tuna, Katsuwonnus pelamis, in an offshore area of the eastern tropical Pacific Ocean. Fishery. Bulletin. 73(2):382-411.

- Blackburn, M. 1976. Review of existing information on fishes in the deep ocean mining environmental study (DOMES) area of the tropical Pacific. IMR Reference No. 76-1, Univ. of Calif., San Diego, La Jolla, CA. 77 pp.
- Block, R.M., G.R. Helz, and W.P. Davis. 1977. Fate and effects of chlorine in marine waters. Chesap. Sci. 18:92-101.
- Bogdanov, D.V., V.A. Sokolov, and N.S. Khromov. 1969. Regions of high biological and commercial productivity in the Gulf of Mexico and Caribbean Sea. Pages 371-380 in All-Union Scientific Research Institute of Marine Fisheries and Oceanography.
- Bogorov, V.G., M.E. Vinogradov, N.M. Voronina, I.P. Kanaeva, and I.A. Suyetova. 1968. Zooplankton biomass distribution in the ocean surface layer. Dokl. Akad. Nauk SSSR, Earth Sci. Sect., 182:235-237.
- Boot, J.L. 1974. Feasibility study of an open cycle ocean thermal difference power plant. M.S. Thesis, Graduate School of the University of Massachusetts. Aug. 1974. 67 pp. plus tables and figures.
- Braswell, J.A., D. F. Lott, and S.M. Hedlicka. 1979. Preliminary evaluation of flow-driven brushes for removal of soft biofouling from heat exchanger tubes in OTEC power plants. Pages 149-162 in Proc. of the Ocean Thermal Energy Conversion (OTEC) Biofouling, Corrosion and Materials Workshop, Jan 8-10, 1979, Rosslyn, Virginia. U.S. Dept. Energy and Argonne National Laboratory. Argonne, IL. ANL/OTEC-BCM-002.
- Bretschneider, C.L. 1977. Final Report: Design wave and current criteria for potential OTEC sites New Orleans, Louisiana - Key West, Florida - Punta Tuna, Puerto Rico - Keahole Point, Hawaii. U.S. Energy Research and Development Administration. 305 pp.
- Brewer, J.H., J. Minor and R. Jacobs. 1979. Feasibility design study land-based OTEC plants. Final Report. Deep Oil Technology, Inc., Long Beach, CA.
- Brewer, P.G. 1978. Carbon dioxide and climate. Oceanus: 21(4):12-17.
- Brooks, N.H. 1960. Diffusion of sewage effluent in an ocean current. Calif. Inst. of Tech., Pasadena, CA. 22 pp.
- Brinton, E. 1962. The distribution of Pacific euphausiids. Bull. Scripps Instn. Oceanogr., 8(2):51-270.
- Bubnov, V.A., V.M. Vasilenko, and L.M. Kiwelevich. 1978. The study of low frequency variability of currents in the tropical Atlantic. In press.
- Burkholder, P.R., L.M. Burkholder, and L.R. Almodovar. 1967. Carbon assimilation of marine flagellate blooms in neritic waters of southern Puerto Rico. Bull. Mar. Sci. 17(1):1-15.
- Burton, D.T. and L.H. Liden. 1977. Biofouling control alternatives to chlorine for power plant cooling water systems: an overview. Presented at the Conference on Water Chlorination. Environmental Impact and Health Effects. Gatlinburg, T. 28 pp.

- Carpenter, E.J., B.B. Peck, and S.J. Anderson. 1974. Survival of copepods passing through a nuclear power station on northeastern Long Island Sound, USA. *Marine Biology*. 24:49-55.
- Castelli, V.J., J.A. Montemarano, and E.C. Fischer. 1975. Organometallic polymers: antifouling materials that know their place. *Mar. Tech. Soc. J.* 9(7):16.
- Churgin, J., and S. Halminski. 1974. Temperature, salinity, oxygen and phosphate in waters off United States volume II. Gulf of Mexico. National Oceanographic Data Center. Washington, D.C. 117 pp.
- Clarke, T.A. 1973. Some aspects of the ecology of lanternfishes (myctophidae) in the Pacific ocean near Hawaii. *Fishery Bulletin*. 71(2):401-433.
- Cochrane, J.D. 1972. Separation off an anticyclone and subsequent developments in the loop current. In Capurro, L.R.A. and J.L. Reid, eds., *Contributions to the Physical Oceanography of the Gulf of Mexico*. 2:91-106.
- Commins, M.L., and A.J. Horne. 1979. Zooplankton from OTEC sites in the Gulf of Mexico and the Caribbean. In G.L. Dugger, ed., *Preprints of the Sixth Ocean Thermal Energy Conversion Conference*. Ocean Systems Branch, Division of Central Solar Technology. USDOE paper 7D-3/1.
- CRC (Chemical Rubber Corporation). 1966. *Handbook of chemistry and physics*. 47th edition. CRC Press.
- Cummings, S.R., D.K. Atwood, and J.M. Parker. 1977. Synthesis and description of the existing historical inorganic nutrient data sets from three potential OTEC sites: northern Gulf of Mexico, Puerto Rico, and St. Croix. Atlantic Oceanographic and Meteorological Laboratories, Miami, FL. 38 pp.
- Dawbin, W.H. 1966. The seasonal migrating cycle of humpback whales. p. 145-170. In: K.S. Norris (Ed.). *Whales, Dolphins, and Porpoises*. U.C. Press.
- Davis, C.C. 1950. Observations of plankton taken in marine waters of Florida in 1947 and 1948. *Quart. J. Fl. Acad. Sci.* 12:67-103.
- Davis, R.E. 1978. Predictability of sea level pressure anomalies over the North Pacific Ocean. *J. Phys. Oceanogr.* 8(2):233-46.
- Dayton, P.K. and R.R. Hessler. 1972. Role of biological disturbance in maintaining diversity in the deep sea. *Deep-Sea Res.*, 19:199-208.
- De, C.P., K.P. Bach, P.S. Nirvan, and F.M. Khandwawala. 1976. Performance of anti-fouling paints in Indian waters. Pages 119-122 in 4th Intl. Congress on Marine Corrosion and Fouling (entre de Recherches et d'Etudes Oceanographiques). Antibes, France.

- Defant, A. 1961. Physical oceanography. Volume I. The MacMillan Co., NY.
- Desrosieres, R. 1969. Surface macrophytoplankton of the Pacific Ocean along the Equator. *Limnology and Oceanography*. 14(4):626-632.
- Ditmars, J.D. 1979. Personal communication. Water Resources Section Energy and Environmental Systems Division, Argonne National Laboratory. Argonne, Ill, 60439.
- Ditmars, J.D. and R.A. Paddock. 1979. OTEC physical and climatic environmental impacts. In G.L. Dugger, ed., Preprints Volume II of the Sixth Ocean Thermal Energy Conversion Conference., June 19-22, 1979. Ocean Systems Branch, Division of Central Solar Technology. U.S. Dept. of Energy. CONF-790631/2. Paper 6A-3/1.
- DOC: See United States Department of Commerce.
- DOE: See United States Department of Energy.
- Drake, R.C. 1977. Increasing heat exchanger efficiency through continuous mechanical tube maintenance. Pages 43-53 in L.D. Jensen, ed., Biofouling Control Procedures: Technology and Ecological Effects. Marcel Decker, NY.
- Dugdale, R.C., and J.J. Goering. 1967. Uptake of new and regenerated forms of nitrogen in primary productivity. *Limnol. and Oceanogr.* 12:196-206.
- Duncan, P., and J. Hemphill. 1977. OTEC environmental package for submarine cable contractors. Washington, D.C.
- Dupont. 1969. Blaster's handbook, fifteenth edition, Dupont.
- Edwards, T.J., W.H. Hunt, L.E. Miller, and J.J. Sevic. 1976. An evaluation of the impingement of fishes at four Duke Power Company steam generating facilities. Pages 373-380 in G.H. Esch and R.W. McFarlane, eds., Thermal Ecology Symposium, April 2-5, 1975. COMF-750425. Tech. Inform. Cent. ERDA.
- El-Sayed, S.Z. 1967. On the biological productivity of the Gulf of Mexico with special reference to the regions off Panama City, FL. Texas A&M Univ., Dept. of Oceanography, College Station, TX. 51 pp.
- EPA: See United States Environmental Protection Agency.
- Eppley, R.W., E.H. Renger, and P.M. Williams. 1976. Chlorine reaction with seawater constituents and the inhibition of photosynthesis of natural marine phytoplankton. *Est. Coast. Mar. Sci.* 4:147-161.
- Eppley, R.W., E.H. Renger, E.L. Venrick, and M.M. Mullin. 1973. A study of plankton dynamics and nutrient cycling in the central gyre of the north Pacific Ocean. *Limnology and Oceanography*. 18(4):534-551.

- Federal Register. 1979. Federal Register Part II, Environmental Protection Agency. National Pollutant Discharge Elimination System; Revision of Regulations. Thursday, June 7, 1979.
- Fisher, N.S. 1977. On the differential sensitivity of estuarine and open-ocean diatoms to exotic chemical stress. *Amer. Natur.* III:871-895.
- Fisher, N.S., L.B. Graham, E.J. Carpenter, and C.F. Wurster. 1973. Geographic differences in phytoplankton sensitivity to PCBs. *Nature.* 241:548-549.
- Francis, E.J. 1977. Investment in commercial development of ocean thermal energy conversion (OTEC) plant-ships. Applied Physics Laboratory, Johns Hopkins University. 200 pp.
- Garrison, L.E., R.G. Martin Jr., and H.L. Berryhill, Jr. 1972. Preliminary tectonic map of the eastern greater Antilles region. Washington, D.C. U.S. Geological Survey; 1.11 x 1.23 m. colored. ([sheet] map I - 732).
- General Electric Company. 1977. Ocean thermal energy conversion mission analysis study: Phase I. Appendices to final report. Tempo Center for Advanced Studies. Washington, D.C. ERHQ/2421-77-1. 2 Vols. 294 pp.
- Gilmartin, M., and N. Revelante. 1974. The "Island Mass" effect on the phytoplankton and primary production of the Hawaiian Islands. *J. Exp. Mar. Biol. Ecol.* 16:181-204.
- Glen, William. 1975. Continental drift and plate tectonics. Charles E. Merrill Publishing Co., Columbus, OH.
- Gooding, R.M., and J.J. Mangnuson. 1967. Ecological significance of a drifting object to pelagic fishes. *Pac. Sci.* 21:486-493.
- Gorbunova, N.N. 1971. Vertical distribution of eggs and larvae of fish in the western tropical Pacific. In: M.E. Vinogradov (Ed.). *Life Activity of Pelagic Communities in the Ocean Tropics.* Available NTIS. TT 72-50035.
- Gordon, D.C., Jr. 1970. Chemical and biological observations at station Gollum, an oceanic station near Hawaii, January 1969 to June 1970. Hawaii Inst. of Geophysics, Report No. 70-22. University of Hawaii. 59 pp.
- Graham, J.W., P.H. Benson, and J.N. Stock. 1977. Use of heat treatment to control biofouling in seawater cooling systems. In *IEEE/MTS Oceans '77, Conference Record.* Volume 1. 23A1 to 23A6. 6 pp.
- Graham, J.W., R.W. Moncreiff, and P.H. Benson. 1975. Heat treatments for the control of marine fouling at coastal electric generating stations. Pages 926-930 in *IEEE/MTS Oceans '75.* IEEE, NY. R.Q.
- Green, R.H. 1978. Sampling design and statistical methods for environmental biologists. Wiley Interscience.

- Grigg, R.W. and D. Doublet. 1979. Hawaii's deep sea jewels. Pages 719-732 in National Geographic. 155(5).
- Gross, M.G. 1972. Oceanography: view of the earth. Prentice-Hall, Inc., Englewood Cliffs, NJ. 580 pp.
- Gundersen, K.R., J.S. Corbin, C.L. Hanson, M.L. Hanson, R.B. Hanson, D.J. Russell, A. Stoller, and O. Yamada. 1976. Structure and biological dynamics of the oligotrophic ocean photic zone off the Hawaiian Islands. Pacific Science 30:45-68.
- Gundersen, K.R., C.W. Mountain, D. Taylor, R. Ohye, and J. Shen. 1972. Some chemical and microbiological observations in the Pacific Ocean off the Hawaiian Islands. Limnology & Oceanography. 17(4):524-531.
- Gundersen, K.R., and R.Q. Palmer. 1972. Report on aquaculture and ocean energy systems for the county of Hawaii. Center for Engineering research, University of Hawaii. Honolulu, HI.
- Haagensen, D.A. 1976. Caribbean zooplankton. Part II. Thecosomata. Office of Naval Research, Dept. of the Navy. Washington, D.C. 162 pp.
- Hagel, D., A.F. Conn, and M.S. Rice. 1977. Methods for cleaning OTEC heat exchangers. Pages 147-158 in R.H. Gray, ed., Proc. Ocean Thermal Energy Conversion (OTEC) Biofouling and Corrosion Symposium. October 10-12, 1977. Seattle, WA. U.S. Dept. of Energy, Division of Solar Energy, Washington, D.C., and Pacific Northwest Laboratory. Richland, Washington, 99352.
- Halminski, S.J. 1975. Temperature, salinity, oxygen, and phosphate in waters off eastern Central America and northern South America. National Oceanographic Data Center. Washington, D.C. 189 pp.
- Hansen, R.M. 1978. Optimizing intake screens for ocean thermal energy conversion power plants. M.S. Thesis. Oregon State University, Corvallis, OR. 108 pp.
- Haraguchi, P. 1975. Forecasting hurricanes in the central Pacific. U.S. Dept. of Commerce. NOAA Technical memorandum NWSTM PR-13. 14 pp.
- Hargraves, P.E., R.W. Brody, and P.R. Burkholder. 1970. A study of phytoplankton in the Lesser Antilles region. Bull. Mar. Sci. 20(2):331-349.
- Hastings, R.W., L.H. Ogren, and M.T. Mabry. 1976. Observations on the fish fauna associated with offshore platforms in the northeastern Gulf of Mexico. Fish. Bull. 74(2):387-401.
- Hazelwood, R.N. 1979. Personal Communication. Global Marine Development Inc., Newport Beach, CA. 92660.
- Heinrich, A.K. 1960. The basic types of vertical distribution of copepods in the central Pacific Ocean. Dokl. Akad. Nauk SSSR, 132(4):921-924.

- Herbison, K. 1979. Personal communication. Southern California Edison.
- Hessler, R.R. and P.A. Jumars. 1977. Abyssal communities and radioactive waste disposal. *Oceanus*, 20(1):41-46.
- Hessler, R.R. 1974. The structure of deep benthic communities from central oceanic waters. Pages 79-93 in C.B. Miller, ed., *The biology of the oceanic Pacific*, Oregon State Univ. Press, Corvallis.
- Hessler, R., and P.A. Jumars. 1974. Abyssal community analysis from replicate box cores in the central north Pacific. *Deep-sea Research*. 21(3):185-209.
- Hirota, J. 1979. Personal communication. University of Hawaii.
- Hirota, J. 1977. DOMES zooplankton. Part 1 Data Report. Deep ocean mining environmental study (DOMES). Unpublished manuscript No. 5, NOAA/Environmental Research Labs. 713 pp.
- Horne, R.A. 1969. Marine chemistry. The structure of water and the chemistry of the hydrosphere. Wiley-Interscience, John Wiley & Sons. New York. 568 pp.
- Howard, G.V. 1963. The matter of availability and the harvest of tunas. FAO. Fisheries Rept. 3(6).
- Howey, T.W. 1979. Personal communication. Lockheed Center for Marine Research, Carlsbad, CA.
- Howey, T.W. 1976. Zooplankton on the Gulf of Mexico: distribution of displacement volume, occurrence of systematic groups, abundance and diversity among copepods. Ph.D. Thesis, Louisiana State University. 99 pp.
- Huang, Ter Chien and H.G. Goodell. 1970. Sediments and sedimentary processes of Eastern Mississippi Cone, Gulf of Mexico. *The Am. Assoc. of Pet. Geol. Bull.* 54(11):2070-2100.
- Hulburt, E.M. 1962. Phytoplankton in the southwestern Sargasso Sea and north equatorial current, February 1961. Pages 307-315 in Contribution No. 1263 from Woods Hole Oceanographic Institution.
- Hunt, C.B. 1967. *Natural Regions of the U.S. and Canada*. W.H. Freeman and Company, San Francisco.
- IMCO. 1978. Aluminum, Bureau of Mines, Mineral Commodity Profile. MCP-14. May 1978.
- Jacobsen, W.E., and R.N. Manley. 1979. OTEC commercialization analysis. Draft. The MITRE Corporation, Metrek Division, McLean, Virginia. 132 pp.

- James, B.M. 1970. Euphausiacean crustacea. In W.E. Pequegnat, and F.A. Chace, Jr., eds., Contributions on the Biology of the Gulf of Mexico. Texas A&M Univ. Oceanogr. Stud., 1:205-229.
- Jirka, G.H., J.M. Jones, and F.E. Sargent. 1979. Modeling the intermediate field of ocean thermal energy conversion discharges. In G.L. Dugger, ed., Preprints Volume II of the Sixth Ocean Thermal Energy conversion Conference. June 19-22, 1979. Washington D.C., Ocean Systems Branch, Div. of Central Solar Technology. U.S. Dept. of Energy. Paper 5C-3/1.
- Johnson, P.W. and A.J. Horne. 1979. Phytoplankton and biomass distribution at potential OTEC sites. p. 7D-4/1-4/5. In G.L. Dugger, ed., Preprints of the Sixth OTEC Conference, Conf.-790631/2.
- Jones, J.I., R.E. Ring, M.D. Rinkel, and R.E. Smith, eds. 1973. A summary of knowledge of the eastern Gulf of Mexico. St. Univ. Sys. of Florida. Tallahassee, FL. 615 pp.
- Jumars, P.A. 1976. Deep-sea species diversity: does it have a characteristic scale? J. Mar. Res., 34(2):217-246.
- Jurasz, C.M. and A.A. Wolman. 1977. Humpback whales in Hawaii. Vessel Census 1976. Mar. Fish. Rev. Paper 1254.
- Kaye, C.A. 1959. Shoreline features and quaternary shoreline changes Puerto Rico. G.S. Professional Paper. 317B.
- Kerns, W.H. 1976. The mineral industry of Hawaii. Pages 225-232 in Bureau of Mines. Minerals Yearbook 1975, V. II. Area Reports: Domestic. U.S. DOI., Washington, D.C., Government Printing Office.
- King, W.G. 1974. Pelagic studies of sea birds in the central and eastern Pacific Ocean. Smithsonian. Contrib. Zool., 158:1-277.
- King, J.E. and T.S. Hida. 1954. Variations in zooplankton abundance in Hawaiian waters, 1950-1952. U.S. Dept. of Interior, Fish and Wildlife Serv. Special Scientific Report: Fisheries No. 118. 65 pp.
- King, J.E. and T.S. Hida. 1957. Zooplankton abundance in the central Pacific, Part II. Fish. Bull. 57:365-395.
- King, J.E. and R.T.B. Iversen. 1962. Midwater trawling for forage organisms in the Central Pacific, 1951-1956. Fish. Bull. Fish and Wildlife Service. 62(210):271-321.
- King, J.E. 1955. Annotated list of birds observed on Christmas Island, October to December 1953. Pac. Sci., 9(1):42-48.
- Kinne, O. 1970. Temperature-invertebrates. Pages 407-517 in O. Kinne, ed., Marine Ecology. Vol. I, Part 1. Wiley-Interscience, New York.
- Knight, H.G., J.D. Nyhart, and R.E. Stein. 1977. Ocean thermal energy conversion. Lexington Books, Lexington, MA. 230 pp.

- Knight, H.G., J.D. Nyhart, and R.E. Stein. 1978. International, legal, political and institutional aspects of OTEC demonstration and development. Final Report to the U.S. Dept. of Energy. Dec. 1978. U.S. Energy Research and Development Administration Contract. No. EG 77-C-01-4118.
- Knight, H.G. 1979. Personal communication. University of Louisiana.
- Koblentz-Mishke, O.J., V.V. Volkovinsky and J.G. Kabanova. 1970. Plankton primary production of the world ocean. Pages 183-193 in W.S. Wooster, ed., Scientific exploration of the South Pacific, Natl Acad. Sci., Wash. D.C.
- Koh, C.Y., and Loh-Nien Fan. 1970. Mathematical models for the prediction of temperature distributions resulting from the discharge of heated water into large bodies of water. U.S. Environmental protection Agency, Water Quality Office. Water Pollution Control Research Series 16130 DWO, October, 1970. 220 pp.
- Kort, V.G., ed. 1967. The Pacific Ocean. Biology of the Pacific Ocean, Book III: Fishes of the open waters. (Transl. from Russian) U.S. Naval Oceanogr. Office, Wash., D.C. 320 pp.
- Lackey, J.B., and J.A. Hines. 1955. The Florida Gulf Coast Red Tide. Fl. Eng. Ind. Exp. St. Bull. Ser. 70. 9(2):3-26.
- Laevastu, Taivo, D.E. Avery, and D.C. Cox. 1964. Coastal currents and sewage disposal in the Hawaiian Islands. Final report. Hawaii Institute of Geophysics, University of Hawaii. 101 pp.
- Lavi, A. and T.N. Veziroglu. 1978. Proceedings of the fifth ocean thermal energy conversion conference: February 20-22, 1978. U.S. Dept. of Energy. CONF-780236. Dist. Category UC-64. 4 Volumes. 209 pp. Available NTIS.
- Leatherwood, S., W.E. Evans, and D.W. Rice. 1972. The whales, dolphins, and porpoises of the eastern north Pacific. A guide to their identification in the water. Naval Undersea Center. Department of the Navy. NUC-TP 282. 175 pp.
- Lee, T.N., R.S.C. Munier, and S. Chiu. 1978. Water mass structure and variability north of St. Croix, U.S. Virgin Islands, as observed during the summer of 1977 for OTEC assessment. University of Miami. Rosentiel School of Marine and Atmospheric Science. Miami, FL. UM-RSMAS #78004. 81 pp.
- Legand, M. and R. Grandperrin. 1972. Feeding habits of deep swimming tunas. Page 519 in R. Fraser, Comp., Oceanography of the South Pacific. New Zealand National Comm. for UNESCO.
- Leipper, D.F. 1970. A sequence of current patterns in the Gulf of Mexico. Jour. Geophy. Res. 75(3): 637-657.

- Leis, J.M. and J.M. Miller. 1976. Offshore distributional patterns of Hawaiian fish larvae. *Mar. Biol.* 36:359-367.
- Linky, E.J. 1979. Lead agency designation and procedures for ocean thermal energy conversion facilities. In G.L. Dugger, ed., Preprints Volume I of the Sixth Ocean Thermal Energy Conversion Conference. June 19-22, 1979. Washington, D.C. Ocean Systems branch, Division of Central Solar Technology. U.S. Dept. of Energy, Paper. 4D-4/1.
- Lockheed Center for Marine Research. 1978. Transmittal concerning toxic coatings. February 16, 1978. 6350 Yarrow Drive. Carlsbad, CA.
- Loeb, V.J. 1979. The ichthyoplankton assemblage of the north Pacific central gyre: spatial and temporal patterns. Ph.D. Thesis. University of California, San Diego; La Jolla, CA. 220 pp.
- Longhurst, A.R. 1976. Interactions between zooplankton and phytoplankton profiles in the eastern tropical Pacific Ocean. *Deep-Sea Res.*, 23:729-754.
- Love, C.M., ed., 1970-75. EASTROPAC Atlases, 1967-68. NMFS Circ. 330. 11 Vol.
- Luijten, J.G.A. 1972. Applications and biological effects of organotin compounds. Pages 931-974 in A.K. Sawyer, ed., *Organotin Compounds*. Vol. 3. Marcel Dekker Co., New York.
- Macalady, D.L., J.H. Carpenter, and C.A. Moore. 1977. Sunlight-induced bromate formation in chlorinated seawater. *Science*. 195:1335-1337.
- MacIssac, J.J., and R.C. Dugdale. 1969. The kinetics of nitrate and ammonia uptake by natural populations of marine phytoplankton. *Deep-Sea Res.* 16: 415-422.
- Mahnken, C.V.W. 1969. Primary organic production and standing stock of zooplankton in the tropical Atlantic ocean - Equalant I and II. *Bull. Mar. Sci.* 19:550-567.
- Mallinckrodt Inc. Science Products Division. 1976. Mallinckrodt Laboratory Chemicals 1976-77 St. Louis, MO. 236 pp.
- Malone, T.C. 1971. The relative importance of nanoplankton and netplankton as primary producers in tropical oceanic and neritic phytoplankton communities. *Limnology and Oceanography*. 16(4):633-639.
- Manar, T.A. 1966. Proceedings of the Governor's Conference on central Pacific fishery resources. State of Hawaii, Honolulu, HI. 266 pp.
- March, B.C., Jr. 1975. Entrainment of organisms at power plants with emphasis on fishes - an overview. Pages 89-106 in S. B. Saila, ed., *Fisheries and Energy Production: A Symposium*. Lexington Books, Lexington, MA.
- Marcuzzi, G. and G. Pilleri. 1971. On the zoogeography of Cetacea. In: G. Pilleri (Ed.). *Investigations on Cetacea*. 3(1):101-170.

- Marina, J. 1979. Personal Communication. Puerto Rico Water Resources Authority, San Juan, Puerto Rico.
- Markel, A.L. 1979. Personal communication. Reynolds Metals Co. Richmond, VA.
- Martin, P.J., and G.O. Roberts. 1977. An estimate of the impact of OTEC operation on the vertical distribution of heat in the Gulf of Mexico, Pages IV-26 - IV-34 in Proc. Fourth Ocean Thermal Energy Conversion (OTEC) Conf., New Orleans, (Mar. 22-24, 1977).
- Matsumoto, W.M. 1958. Description and distribution of larvae of four species of tuna in central Pacific waters. Fish. Bull. Fish and Wildlife Service. Vol. 58(128):71 pp.
- Maul, G.A. 1977. The annual cycle of the gulf loop current Part I: observations during a one-year time series. J. Mar. Res. 35(1):29-47.
- Maynard, S.D., R.V. Riggs, and J.F. Walters. 1975. Mesopelagic micronekton in Hawaiian waters: faunal composition, standing stock, and diel vertical migration. Fish. Bull. 73(4):726-736.
- McGowan, J.A. 1974. The nature of oceanic ecosystems. Pages 9-28 in C.B. Miller, ed., The Biology of the Oceanic Pacific. Oregon State Univ. Press.
- McGowan, J.A. 1971. Oceanic biogeography of the Pacific. Pages 3-74 in B.M. Funnell and W.R. Riedel, eds., The Micropaleontology of Oceans, Cambridge Univ. Press.
- Michel, H.B., and M. Foyo. 1976. Caribbean zooplankton. Part I. Siphonophora, Heteropoda, Copepods, Euphausiacea, Chaetognatha, and Salpidae. Office of Naval Research, Dept. of the Navy. Washington, D.C. 549 pp.
- Miller, J.M. 1979. Nearshore abundance of tuna (Pisces: scombridae) larvae in the Hawaiian Islands. Bul. of Mar. Sci., 29(1):10-26.
- Moiseev, P.A. 1971. The living resources of the world ocean. Israel Prog. for Sci. Trans., Jerusalem. Nat. Sci. Found., Washington, D.C. 334 pp.
- Molinari,, R.L. and F. Chew. 1979. Ocean thermal and current structures in the tropical south Atlantic relative to the placement of a grazing OTEC plant. U.S. Dept. of Commerce NOAA Technical Memorandum ERL AOML-35. 57 pp.
- Molinari, R.L. AND J.F. Festa. 1978. Ocean thermal and velocity characteristics of the Gulf of Mexico relative to the placement of a moored OTEC plant. NOAA Technical Memorandum ERL AOML-33. Atlantic Oceanographic and Meteorological Laboratories. Miami, FL. 179 pp.

- Montemarano, J.A., and E.J. Dyckman. 1973. Antifouling organometallic structural plastics. R.D. Rept. No. 4159. Nav. Ship Res. Devel. Cent. Bethesda, MD. 8 pp.
- Morello, A., 1978. Bottom power cables connecting floating power stations to shore. A. Lavi and T.N. Veziroglu, eds., Proceedings of the Fifth Ocean Thermal Energy Conversion Conference, February 22, 1978. U.S. Dept. of Energy. Conf-780236. Sept. 1978. Vol.(1):II-5 to II-21.
- Morrison, J.M. and W.D. Nowlin, Jr. 1977. Repeated nutrient, oxygen, and density sections through the loop current. Jour. Mar. Res., 35(1):105-128.
- Morse, J.W., J. deKanel, and L. Craig, Jr. 1978. A literature review of the saturation state of seawater with respect to calcium carbonate and its possible significance for scale formation on OTEC heat exchangers. Univ. of Florida. Prepared for Pacific Northwest Lab. under agreement No. B-07455 A-E.
- Muller, R. G. 1971. Phytoplankton observations through fourteen months at a tropical oceanic station. M.S. Thesis. University of Hawaii. 74 pp.
- Nakamura, E.L. 1955. Abundance and distribution of zooplankton in Hawaiian waters, 1955-56. U.S. Dept. of the Interior, Fish & Wildlife Service, Special Scientific Report, Fisheries #544. 20 pp.
- Namias, J. 1979. Personal communication. Scripps Institute of Oceanography, University of California, San Diego, Dept. Oceanography.
- Nanda, V.P. 1979. Legal and institutional aspects., In G.L. Dugger, ed., Preprints: of the Sixth Ocean Thermal Energy Conversion Conference. June 19-22, 1979. Washington, D.C., Ocean Systems Branch, Division of Central Solar Technology., U.S. Dept. of Energy. Paper 4D-2/1.
- Natarajan, K.V. 1970. Toxicity of ammonia to marine diatoms. J. Wat. Poll. Cont. Fed. 42(5):R184-R190.
- Nath, J.H., C.B. Miller, J.W. Ambler, and R.M. Hansen. 1977. Engineering and biological aspects of the screens for OTEC intake systems. U.S. Energy Research and Development Administration. Contract No. EY-76-S-06-2227. RLO/2227/T26-2. 157 pp.
- Nishimura, M. 1963. Investigations of tuna behavior by Fish Finder. FAO Fisheries Rept. 3(6).
- Nishiwaki, M. 1966. Distribution and migration of the larger cetaceans in the north Pacific shown by Japanese whaling results. In: Norris, K.S. (Ed.). Whales, Dolphins, and Porpoises. UC Press.
- Neumann, G., and W.J. Pierson, Jr. 1966. Principles of physical oceanography. Prentice-Hall.
- Nossaman, Kruegar, and Marsh, Inc. 1979. OTEC Act of 1980. (Draft). 64 pp.

- Norris, K.S. and R.R. Reeves (Eds.). 1978. Report on a workshop on problems related to Humpback Whales (Megaptera novaengliae) in Hawaii. Final Report to U.S. Marine Mammal Commission. Contract MMFAC018.
- Nowlin, W.D., Jr., and J.M. Hubertz. 1972. Contrasting summer circulation patterns for the eastern Gulf-Loop current versus anticyclonic ring. In L.R.A. Cappuro and J.L. Reid, eds., Contribution on the Physical Oceanography of the Gulf of Mexico. 2:119-138.
- Nyhart, J.D. 1979. Legal aspects of siting OTEC plants offshore the United States on the high seas, and offshore other countries. In G.L. Dugger, ed., Preprints Volume II of the Sixth Ocean Thermal Energy Conversion Conference, June 19-22, 1979, Washington, D.C., Ocean Systems Branch, Division of Central Solar Technology, U.S. Dept. of Energy, paper 4D-1/1.
- Ocean Data Systems, Inc. 1977a. OTEC thermal resource report for Hawaii. Ocean Data Systems, Inc. 16 pp., 4 appends., 2 tbls., 16 figs. Monterey, CA.
- Ocean Data Systems, Inc. 1977b. OTEC thermal resource report for Florida east coast. Energy Research and Development Administration, Division of Solar Energy, Contract No. EC-77-C-01-4028. Washington, D.C. 65 pp.
- Ocean Data Systems, Inc. 1977c. OTEC thermal resource report for Western Gulf of Mexico. Energy Research and Development Administration, Division of Solar Energy, Contract No. EC-77-C-01-4028. Washington, D.C. 60 pp.
- Ocean Data Systems, Inc. 1977d. OTEC thermal resource report for central Gulf of Mexico. Energy Research and Development Administration, Division of Solar Energy, Contract No. EC-77-C-01-4028. Washington, D.C. 103 pp.
- Ocean Data Systems, Inc. 1977e. OTEC thermal resource report for Key West area. TID-27592. Energy Research and Development Administration. Contract No. EC-77-C-01-4028. Washington, D.C. 19 pp.
- Ocean Data Systems, Inc. 1977f. OTEC thermal resource report for Puerto Rico. Energy Research and Development Administration, Division of Solar Energy. Contract No. EC-77-C-01-4028. Washington, D.C. 60 pp.
- Ocean Data Systems, Inc. 1979a. OTEC thermal resource report for Sri Lanka. U.S. Department of Energy. Contract No. ET-78-C-01-2898. Washington, D.C. 20 pp.
- Ocean Data Systems, Inc. 1979b. OTEC thermal resource report for Dampier Land, Australia. U.S. Department of Energy. Contract No. ET-78-C-01-2898. Washington, D.C. 20 pp.
- Ocean Data Systems, Inc. 1979c. OTEC thermal resource report for Mombasa. U.S. Department of Energy. Contract No. ET-78-C-01-2898. Washington, D.C. 20 pp.
- Ocean Data Systems, Inc. 1979d. OTEC thermal resource report for Jakarta, Indonesia. U.S. Department of Energy. Contract No. ET-78-C-01-2898. Washington, D.C. 25 pp.

- Ocean Data Systems, Inc. 1979e. OTEC thermal resource report for Guam. U.S. Department of Energy. Contract No. ET-78-C-01-2898. Washington, D.C. 15 pp.
- Ocean Data Systems, Inc. 1979f. OTEC thermal resource report for Manila, Philippine Islands. U.S. Department of Energy. Contract No. ET-78-C-01-2898. Washington, D.C. 20 pp.
- Ocean Data Systems, Inc. 1979g. OTEC thermal resource report for Pacific Plant Ship 5-10° N 90-95° W. U.S. Department of Energy. Contract No. ET-78-C-01-2898. Washington, D.C. 20 pp.
- Ocean Data Systems, Inc. 1979h. OTEC thermal resource report for western coast of Mexico. U.S. Department of Energy. Contract No. ET-78-01-2898. Washington, D.C. 20 pp.
- Ocean Data Systems, Inc. 1979i. OTEC thermal resource report for Ivory Coast. U.S. Department of Energy. Contract No. ET-78-01-2898. Washington, D.C. 15 pp.
- Ocean Data Systems, Inc. 1979j. OTEC thermal resource report for Caribbean Sea Plant Ship 13-15° N, 75-80° W. U.S. Department of Energy. Contract No. ET-78-C-01-2898. Washington, D.C. 25 pp.
- Office of Technology Assessment. 1978. Renewable ocean energy sources, Part I. Ocean Thermal Energy Conversion. Washington, D.C. 44 pp.
- Omori, M. 1974. The biology of pelagic shrimps in the ocean. *Advances in Mar. Biol.* 12:233-324.
- Owen, R.W. and B. Zeitzschel. 1970. Phytoplankton production: seasonal change in the Oceanic eastern tropical Pacific. *Mar. Biol.* 7:32-36.
- Owens, W.L. 1978. Correlation of thin film evaporation heat transfer coefficient for horizontal tubes. Pages 71-89 in A. Lavi and T.N. Veziroglu, eds., *Proceedings of the Fifth Ocean Thermal Energy Conversion Conference, February 20-22, 1978.* U.S. Dept. of Energy. CONF-780236. Sept. 1978. (3)Vol. I.
- Owre, H.B. and M. Foyo. 1964. Report on a collection of copepoda from the Caribbean Sea. *Bull. Mar. Sci., Gulf Caribb.*, 14(2):359-372.
- Pandolfini, P.P., W.H. Avery and F.K. Hill. 1979. Experiments on ultrasonic cleaning of a shell-less folded aluminum tube, OTEC heat exchanger. Pages 8A-1/1-1/5 in G.L. Dugger, ed., *Preprints of the Sixth OTEC Conference, June 19-22, 1979.* Washington, D.C., U.S. Dept. of Energy. Volume I.
- Parsons, T. and M. Takahashi. 1973. *Biological oceanographic processes.* Pergamon Press. 186 pp.

- Patzert, W.C., K. Wyrтки, H.J. Santamore. 1970. Current measurements in the central north Pacific Ocean. Hawaii Institute of Geophysics, Univ. Hawaii. Honolulu, HI. 65 pp.
- Pavlova, E.V., T.S. Petipa, and Y.I. Sorokin. 1971. Bacterioplankton as food for pelagic marine organisms. In M.E. Vinogradov, ed., Life Activity of Pelagic Communities in the Ocean Tropics.
- Payne, S.F. 1978. A summary of marine mammals in Hawaiian waters. Earth Sciences Division, Lawrence Berkeley Laboratory, University of California. Berkeley, CA. 43 pp.
- Pickard, G.L. 1966. Descriptive physical oceanography. Pergamon Press, New York. 200 pp.
- Pieroni, C.A., H.T. Traut, B.S. Clark, and W.G. Smith. 1978. OTEC riser cable: problems and cost. A. Lavi and T.N. Veziroflu, eds., Proceedings at the Fifth Ocean Thermal Energy Conversion Conference, February 20-22, 1978. U.S. Dept. of Energy. CONF-780236. Sept. 1978. Volume I:II-22-II-43.
- Pinckert, W.F. & Associates. 1978. Planning for the impacts of Guam energy facility expansion. A preliminary assessment. Coastal Management Program, Bureau of Planning, Government of Guam, Agana, Guam. 162 pp.
- Pinsky, Gerald. 1979. Socioeconomic raw data. Economic Development Administration, Commonwealth of Puerto Rico. New York hdqts. 30 pp., figs.
- Quinby-Hunt, M. 1979. Comparison of nutrient data from four potential OTEC sites. In: G.L. Dugger (Ed.). Preprints of the Sixth Ocean Thermal Energy Conversion Conference. Ocean Systems Branch, Division of Central Solar Technology. USDOE paper 7D-211.
- Ray, S.S., R.L. Snipes, and D.A. Tomljanovich. 1976. A state of the art report on intake technologies. EPA-600/7-76-020. Prepared for Off. Energy, Minerals, and Industry; Off. Res. and Devel.; U.S. Environmental Protection Agency; Washington, D.C. 83 pp.
- Redfield, A.C., B.H. Ketchum, and F.A. Richards. 1963. The influence of organisms on the composition of seawater. Pages 26-77 in M.N. Hill, ed., The Sea. Vol. 2. Interscience.
- Reid, J.L. 1962. On circulation, phosphate-phosphorus content, and zooplankton volumes in the upper part of the Pacific Ocean. Limnol. Oceanogr., 7(3):287-306.
- Reid, J.L. 1965. Intermediate waters of the Pacific Ocean. The Johns Hopkins Press. Baltimore, MD. 200 pp.
- Rice, D.W. and A.A. Wolman. 1978. Humpback Whale census in Hawaiian waters. February 1977. Preliminary Report of an Ongoing Study. Appendix V. In: Norris and Reeves (Eds.), Report on a Workshop on Problems Related to Humpback Whales in Hawaii. MMC Contract MM7AC018.

- Riggs, F.V. 1977. Vertical distribution and migration patterns of the Hawaiian mid-water penaeidae. M.S. Thesis. University of Hawaii. 47 pp.
- Roger, C. 1974. Les euphausiaces du Pacifique equatorial et sud tropical. Mem. O.R.S.T.O.M. No. 71. xxii + 265 pp.
- Rosales, L.A., T.C. Dvorak, M.M. Kwan, and M.P. Bianchi, 1978. Materials selection for ocean thermal energy conversion heat exchangers. In A. Lavi and T.N. Veziroglu, eds., Proceedings at the Fifth Ocean Thermal Energy Conversion Conference, February 20-22, 1978. U.S. Department of Energy. CONF-786236. Sept. 1978. Vol(4)VIII:231-264.
- Rowe, G.T., P.T. Polloni, and S.G. Horner. 1974. Benthic biomass estimates from the northwestern Atlantic Ocean and the northern Gulf of Mexico. Deep-Sea Res., 21:641-650.
- Rowe, G.T., and D.W. Menzel. 1971. Quantitative benthic samples from the deep Gulf of Mexico with some comments on the measurement of deep-sea biomass. Bull. Mar. Sci. 21(2):556-566.
- Ryther, J.H., and W.M. Dunstan. 1971. Nitrogen, phosphorus and eutrophication in the coastal marine environments. Science. 171:1008-1013.
- Saifullah, S.M. 1978. Inhibitory effects of copper on marine dinoflagellates. Marine Biology. 44(4):299-308.
- Saunders, R.P., and D.A. Glenn. 1969. Diatoms in memoirs of the hourglass cruises. Pages 1-119 in Vol. 1, PT.3, Florida Department of Natural Resources. Mar. Res. Lab., St. Petersburg, FL.
- Schmitt, Robert C., ed. 1977. State of Hawaii Data Book: a statistical abstract. Department of Planning and Economic Development. Honolulu, HI. 339 pp.
- Schmitt, Robert C., ed. 1978. State of Hawaii Data Book: a statistical abstract. Department of Planning and Economic Development, Honolulu, HI. 379 pp.
- Schneider, A.L. and R.C. Lambert. 1978. U.S. Coast Guard risk analysis. 21st Annual American Institute of Chemical Engineers Meeting. Miami Beach, Florida. November 12-16, 1978.
- Schubel, J.R. 1975. Some comments on the thermal effects of power plants on fish eggs and larvae. Pages 31-54 in S.B. Sails, ed., Fisheries and Energy Production: A Symposium. D.C. Heath and Co., Lexington, Mass.
- Schulenberger, Eric. 1978. Vertical distributions, diurnal migrations and sampling problems of hyperiid amphipods in the North Pacific Gyre. Repr. from Deep-Sea Research, 25(7):605-623.

- Sciubba, C. 1978. New concepts enhance position of open and hybrid OTEC power cycles. Pages VII 45 - VII 67. In: A. Lavi (Ed.), Proceedings of the Fifth OTEC Conference. U.S. Dept. of Energy. CONF-780236.
- Scripps Institute of Oceanography. 1969. Physical, chemical and biological data report, CLIMAX II Expedition. 27 August-13 October, 1969. SIO Reference 75-6. University of California, San Diego; La Jolla, CA.
- Shepard, F.P. 1973. Pages 219-221 in Submarine geology. New York: Harper and Row.
- Shomura, R.S. and E.L. Nakamura. 1969. Variations in marine zooplankton from a single locality in Hawaiian waters. Fish. Bull. 68 (1):87-99.
- Sinay-Friedman, L. 1979a. Supplement to the draft environmental impact assessment ocean thermal energy conversion (OTEC) preoperational ocean test platform. Volume 1 and 2. TRW Defense and Space Systems Group.
- Soares, M., E. Shallenberger, and R. Antinoja. 1977. The Hawaiian Humpback Whale: population characteristics. Abstract. Second Conference on the Biology of Marine Mammals. December, 1977.
- Slobodkin, L.B. and H.L. Sanders. 1969. On the contribution of environmental predictability to species diversity. Brookhaven Symp. Biol. 22:82-95.
- Sorokin, Y.I. 1971a. Abundance and production of bacteria in the open waters of the Central Pacific. Oceanology II(1):85-94.
- Sorokin, Y.I. 1971b. Quantitative evaluation of the role of bacterioplankton in the biological productivity of tropical Pacific waters. In Vinogradov, M.E., ed., Life Activity of Pelagic Communities in the Ocean Tropics. (Transl. from Russian) Nat. Mar. Fish. Serv. Israel Program for Scientific Translations. 298 pp.
- Squire, J.L., Jr. and S.E. Smith. 1977. Anglers' guide to the United States Pacific Coast. U.S. Dept. of Commerce. NOAA. 139 pp.
- State of Hawaii. 1978. The economy of Hawaii. Annual Economic Report and Outlook. Honolulu, HA.
- Steele, J.H. 1964. A study of production in the Gulf of Mexico. Jour. Mar. Res. 22(3):211-222.
- Steidinger, K.A., and J. Williams. 1970. Dinoflagellates. Pages 1-251 in Memoirs of the Hourglass Cruises, Vol. II. Fla. Dept. Nat. Resources Mar. Res. Lab.
- Stock, J.N., and A.R. Strachan. 1977. Heat as a marine fouling control program at coastal electric generating stations. Pages 55-62 in L. Jensen, ed., Biofouling Control Procedures. Marcel Dekker Inc., New York.
- Stommel, H. 1960. The Gulf Stream, a physical and dynamical description. University of California Press, Berkeley and Los Angeles. 202 pp.

- Storey, M. 1937. The relation between normal range and mortality of fishes due to cold at Sanibel Island, Florida. *Ecology*. 18:10-26.
- Strahler, Arthur N. 1971. *The earth sciences*. New York: Harper & Row.
- Strasburg, D.W. 1960. Estimates of larval tuna abundance in the Central Pacific. *Fish. Bull.*, Fish and Wildlife Service. 167:231-255.
- Stretch. 1979. Personal Communication. Hawaiian Electric Company, Oahu, HI.
- Sullivan, S. Mack. 1979. A review of the biological information relating to OTEC operation. Sixth OTEC Conference, Washington, D.C. Interstate Electronics Corporation. Anaheim, CA. 10 pp.
- Sverdrup, H.U., M.W. Johnson, and R.H. Fleming. 1942. *The oceans: their physics, chemistry, and general biology*. Prentis-Hall, Englewood Cliffs, NJ. 1087 pp.
- Sweeney, J.W. 1975. The mineral industry of Puerto Rico, the Virgin Islands, and Pacific Island possessions. Pages 653-667 in Bureau of Mines, Minerals Yearbook 1975, V. II. Area Reports: Domestic. U.S.D.O.I., Washington, D.C., Government Printing Office.
- Takahashi, T., R.F. Weiss, C.H. Culberson, J.M. Edmond, D.E. Hammond, C.S. Wong, Y.H. Li, and A.E. Bainbridge. 1970. A carbonate chemistry profile at the 1969 GEOSECS intercalibration station in the eastern Pacific Ocean. *J. Geophysical Res.* 75(36)7648-7666.
- Taylor, D. and L. Berner, Jr. 1970. The heteropods (Mollusca gastropoda). In pages 231-244 in W.E. Pequegnat and F.A. Chace, Jr., eds., *Contributions on the Biology of the Gulf of Mexico*. Texas A & M University Oceanographic Studies, Vol. I. Gulf Publishing Co., Houston, TX.
- Tetra Tech. 1977. A second estimate of the OTEC thermal resource of the southeastern Gulf of Mexico. Unpublished manuscript submitted to Dr. Lloyd Lewis, Dept. of Energy. Washington, D.C. 13 pp.
- Thiel, H. 1975. The size structure of the deep-sea benthos. *Int. Revues Hydrobiol.* 60:576-606.
- Thiriou-Quievreux, C. 1973. Heteropoda. *Oceanogr. Mar. Biol. Ann. Rev.*, 11:237-261.
- Thomas, W.H. 1970. Effect of ammonium and nitrate concentration on chlorophyll increases in natural tropical Pacific plankton populations. *Limnol. and Oceanogr.* 15:386-394.
- Thomas, D.L. 1979. A review of water intake screening options for coastal water users with recommendations for ocean thermal energy conversion (OTEC) plants. Argonne, Illinois, Argonne National Laboratory, DOE Contract #W-31-109-Eng-38. 37 pp.

- Traut, R.T. 1979. Personal Communication. Simplex Wire and Cable Company. Portsmouth, New Hampshire.
- Uchida, R.N. 1978. The fish resources of the western central Pacific islands. FAO Fish. Circular No. 712. United Nations, Rome.
- Uchupi, Elazar and K.O. Emery. 1968. Structure of the continental margin off Gulf Coast of the United States. Am. Ass. of Pet. Geol. Bull. 52(7):1162-1193.
- Ulanowicz, R.E. 1975. The mechanical effects of water flow on fish eggs and larvae. Pages 77-87 in Fisheries and Energy Production: A Symposium. D.C. Heath and Co., Lexington, MA.
- United States Army Corps of Engineers. 1971. Hawaii regional inventory of the national shoreline study. Honolulu, U.S. Army Corps of Engineers.
- United States Coast Guard. 1972. Rules and regulations for military explosives and hazardous munitions. USCG No. 108, April 1, 1972.
- United States Coast Guard. 1973. Rules and regulations for cargo and miscellaneous vessels, CG. 258.
- United States Coast Guard. 1976. Chemical data guide for bulk shipment by water. USCG No. 398.
- United States Coast Guard. 1977. Systems safety analysis of a commercial vessel, Coast Guard Report No. CG-D-39-77. Battelle Columbus Labs. November 1977.
- United States Coast Guard. 1978. Requirements for mobile offshore drilling units, Title 46 - Shipping. Federal Register Vol. 43, No. 233, Monday, December 4, 1978.
- United States Coast Guard. 1979. U.S. Coast Guard Marine Board of Investigation Report No. USCG 16732/61865. Ocean Express.
- United States Department of Commerce. 1972. Puerto Rico coastal management program and draft environmental impact statement. Vol. 2. Office of Coastal Zone Management. Washington, D.C. 198 pp.
- United States Department of Commerce. 1978. Draft environmental impact statement and proposed coastal management program for the state of Hawaii. Office of Coastal Zone Management. NOAA. Washington, D.C. 401 pp.
- United States Department of Commerce. 1979a. Guam coastal management program and final environmental impact statement. Volume I. U.S. NODC. NOAA. Office of Coastal Zone Management, Bureau of Planning, Government of Guam. 249 pp., attachments.
- United States Department of Commerce. 1979b. The Virgin Islands coastal management program and draft environmental impact statement. Rockville, Maryland: U.S. Department of Commerce. 180 pp. appendices.

- 1979c. The first five years of coastal zone management. An initial assessment. The Office of Coastal Zone Management, National Oceanic and Atmospheric Administration, Washington, D.C. March, 1979. 60 pp.
- United States Department of Energy. 1977a. Ocean thermal energy conversion mission analysis study. Phase I. Volume I. Final Report. Division of Solar Energy, June 1977. DSE/2421-1. 85 pp.
- United States Department of Energy. 1977b. Addendum to: OTEC environmental package for submarine cable contractors, tropical cyclones and geology. Dept. of Energy. Washington, D.C. 18 Nov. 1977. 37 pp.
- United States Department of Energy. 1978a. Large scale distribution of OTEC thermal resource. Delta T (°C) between surface and 1,000 m depth. ODSI. Contract No. ET-78-C-01-2898.
- United States Department of Energy. 1978b. Principal electric facilities, Alaska, Hawaii, Puerto Rico, Virgin Islands. U.S. DOE, Energy Information Administration DOE/EIA-0057/11. Washington, D.C. 55 pp.
- United States Department of Energy. 1978c. Environmental development plan (EDP) Ocean Thermal Energy Conversion 1977. Available NTIS. DOE/EDP-0006. Springfield, VA. 48 pp.
- United States Department of Energy. 1979a. Environmental development plan. Ocean thermal energy conversion. August, 1979. U.S. DOE Assistant Secretary for Energy Technology, Assistant Secretary for Environment. 48 pp.
- United States Department of Energy. 1979b. Transmittal from VSE Corporation. 2550 Huntington Ave. Alexandria, VA.
- United States Department of Energy. 1979c. Environmental assessment, ocean thermal energy conversion (OTEC) program. Preoperational ocean test platform. U.S. DOE, Assistant Secretary for Energy Technology, Washington, D.C. 20545. DOE/EA-0062. 381 pp.
- United States Department of Energy. 1979d. Report on the meeting held by the DOE-EPA working group on ocean thermal energy conversion, June 18, 1979. Ocean Systems Branch, U.S. Dept. of Energy. Oceans Programs Branch, U.S. Environmental Protection Agency, Oct. 1979. 28 pp.
- United States Department of Energy. 1979e. Safety analysis and review system. Office of Assistant Secretary for Environment. Order DOE 5481.1. 12 pp.
- United States Department of Transportation. 1973. Rules and regulations for cargo and miscellaneous vessels, subchapter I, CG-257. Coast Guard (USCG) Washington, D.C., 179 pp.
- United States Department of State. 1978. Economic resource zone map No. 503798 6-78. Intelligence and Research Bureau. Maps and Publication Coordinator. 2001 C Street, NW. Washington, D.C. 20520.

- United States Department of State. 1979. Maps: International boundaries in the Gulf of Mexico. Map Branch. Washington, D.C.
- United States Environmental Protection Agency. 1976a. Quality criteria for water. United States EPA, Washington, D.C. 20460. 256 pp.
- United States Environmental Protection Agency. 1976b. Development document for best technology available for the location, design, construction and capacity of cooling water intake structures for minimizing adverse environmental impact. United States EPA 440/1-76/015-a. 263 pp.
- United States Environmental Protection Agency. 1977. Ammonia. Environmental health effects research series. Washington, D.C. Report #EPA-600/L-77-054. 690 pp.
- United States Naval Oceanographic Office. 1965. Oceanographic atlas of the north Atlantic Ocean. Section I, Tides and Currents. Publication No. 700. Washington, D.C. 75 pp.
- United States Naval Weather Service Command. 1970a. Summary of synoptic meteorological observations. North American coastal marine areas; Volume 5; Areas 14-16. Available NTIS. Washington, D.C. 474 pp.
- United States Naval Weather Service Command. 1970b. Summary of synoptic meteorological observations. North American coastal marine areas; Volume 6; Areas 17-19. Available NTIS. Washington, D.C. 475 pp.
- United States Naval Weather Service Command. 1971. Synoptic summaries of meteorological observations. Volume I. Areas 1-4: Hawaiian and selected north Pacific island coastal areas. 632 pp.
- United States Naval Weather Service Command. 1974. Summary of synoptic meteorological observations Caribbean and nearby island coastal marine areas. Volume 4. Area 18-Hispaniola North, Area 19-Santo Domingo, Area 20-Mona Passage, Area 21-Puerto Rico South, Area 22-Puerto Rico North, Area 23-Vieques. AD/A-001 457. Distributed by NTIS. U.S. Department of Commerce. Washington, D.C. 230 pp.
- USGS. 1975. Natural hazards on the island of Hawaii. Inf - 75-18.
- USGS, 1978. Topographic map of Guam, 1:50,000
- Van Nostrand Reinhold Co. 1979. Dangerous properties of industrial materials. Fiftieth edition, Sax, NJ.
- Venrick, E.L., J. A. McGowan and A.W. Mantyla. 1973. Deep maxima of photosynthetic chlorophyll in the Pacific Ocean. Fish. Bull., 71 (1): 41-52.
- Verschueren, K. 1977. Handbook of environmental data on organic chemicals. Van Nostrand Reinhold Co., New York.

- Vinogradov, M.E. 1961. Quantitative distribution of deep-sea plankton in the western Pacific and its relation to deep-water circulation. *Deep Sea Research*. 8 (3/4):251-258.
- Vinogradov, M.E. 1970. Vertical distribution of the oceanic zooplankton. (English Transl.) National Tech. Info. Serv. (NTIS) transl. no. TT-69-59015. NTIS Springfield, VA. 339 pp.
- Vinogradov, M.E. and Y.A. Rudyakov, 1971. Diurnal variations in the vertical distribution of the plankton biomass in the equatorial west Pacific. Pages 198-209 in Vinogradov, M.E., ed., *Life Activity of Pelagic Communities in the Ocean Tropics*. Transl. from Russian. Akad. Nank USSR. Israel Prog. Scientific Translation. 1971.
- Waid, R.L. 1979. Discharge parameters for Lockheed Space and Missiles Company, Inc. design of commercial size OTEC plants. Personal Communication. Oct. 1, 1979.
- Waldron, K.D. 1964. Fish schools and bird flocks in the central Pacific Ocean, 1950-1961. U. S. Fish & Wildlife Serv., Spec. Sci. Rept., Fisheries No. 464. 20 pp.
- Walters, J.F. 1976. Ecology of Hawaiian sergestid shrimps (*Penaeidea sergestidae*). *Fish. Bull.* 74(4):799-836.
- Wangersky, P.J. 1969. Distribution of suspended carbonate with depth in the ocean. *L & O*. 14:929-933.
- Washom, B.J., J.M. Nilles, R.E. Lutz, D. Nachtigal, and J.R. Schmidhauseer. 1977. Incentives for the commercialization of ocean thermal energy conversion technology. U.S. DOE. WASHINGTON, D.C. PB-2680977. 353 pp.
- Watt, A.D., R.S. Matthews, and R. E. Hathaway. 1977. Open cycle ocean thermal energy conversion. A preliminary engineering evaluation. Final report. U. S. Dept. of Energy. Washington, D.C. ALO/3723-73/3 130 pp.
- Watt, A.D., R. S. Mathews, and R. E. Hathaway. 1978. Open cycle thermal energy conversion. A preliminary engineering evaluation. In A. Lavi and T. Veziroglu, eds., *Fifth Ocean Thermal Energy Conversion Conference*. Volume III Clean Energy Research Institute, University of Miami. Available NTIS. STOCK NO. 061-000-00180-8.
- Weight, R. H. 1958. Ocean cooling water system for 800 MW power station. *American Society of Civil Engineers, Journal of the Power Division* 84 (p6):1888-1-1888-22.
- Weiss, R.F. 1970. The solubility of nitrogen, oxygen and argon in water and seawater. Pages 721-735 in *Deep-Sea Research*.
- White, W.B., and R.L. Haney. 1978. The dynamics of ocean climate variability. *Oceanus*, 21(4):33-39.

- Wiebe, P.H., S. Boyd, and J.L. Cox. 1975. Relationships between zooplankton displacement volume, wet weight, dry weight, and carbon. *Fish. Bull.* 23(4):777-786.
- Wilde, P. 1977. Mineralized scale formation during OTEC operations - a preliminary caution. Lawrence Berkeley Laboratories. University of California. Berkeley, CA. 29 pp.
- Wilde, P. 1979. Cruise data from candidate OTEC sites. Lawrence Berkeley Laboratory. Unpublished reports and data sheets.
- Wilde, P. and J. Sandusky. 1977. Cruise report to the Lawrence Berkeley Laboratory on the plankton at station 29°N 88°W during February and March, 1978. U.S. Department of Energy Washington, D.C. 40 pp.
- Williams, J., and R.M. Ingle. 1972. Ecological notes on *Gonyaulax monilata* blooms along the west coast of Florida. Page 1-1 in Florida Dept. of Natural Resources. Mar. Res. Lab. Leaf. Ser. Vol 1, Part 1, No. 1.
- Wyrтки, K., J.B. Burks, R.C. Latham and W. Patzert. 1967. Oceanographic observations during 1965-1967 in the Hawaiian archipelago. Univ. of Hawaii, Hawaii Inst. of Geophysics. 151 pp.
- Wyrтки, K., V. Graefe, and Wm. Patzert. 1969. Current observations in the Hawaiian archipelago. July 1969., Hawaii Institute of Geophysics., Univ. of Hawaii. HIG-69-15 27 pp., tables, figures.
- Yabe, H. and S. Ueyanagi. 1961. Contributions to the study of the early life history of the tunas. Paper N VII-6. Pacific Tuna Biology Conference. Honolulu, Hawaii.
- Yarema, G.S., 1979. Correspondence. August 6, 1979. FO107-000. Law offices, Nossaman, Krueger, and Marsh, Los Angeles, CA. 90071.
- Young, R.E. 1978. Vertical distribution and photosensitive vesicles of pelagic cephalopods from Hawaiian waters. *Fish. Bull.* 76(3):583-616.
- Youngbluth, M.J. 1975. Zooplankton studies 1973 and 1974. Pages 35-36 in E.D. Wood et al., Cabo Mala Pascua Environmental Studies. Repr. from: Tech. Rept. #188, Puerto Rico Nuclear Center.
- Youngbluth, M.J. 1977. Diel changes in the composition of tropical zooplankton assemblages from coastal waters around Puerto Rico. Unpublished. Harbor Branch Foundation, Inc., Fort Pierce, Florida. 33450. 9 pp., figures.
- Youngbluth, M.J. 1977. The size and composition of zooplankton populations in the coastal waters of Puerto Rico. Unpublished. Harbor Branch Foundation, Inc., Fort Pierce, Florida 19pp.
- Ziemann, D.A. 1975. Patterns of vertical distribution, vertical migration, and reproduction in the Hawaiian mesopelagic shrimp of the family Oplophoridae. Ph.D. Thesis. University of Hawaii. 112 pp.