

# Challenges, Uncertainties and Issues Facing Gas Production From Gas Hydrate Deposits

G.J. Moridis, SPE, Lawrence Berkeley National Laboratory; T.S. Collett, SPE, US Geological Survey; M. Pooladi-Darvish, SPE, University of Calgary and Fekete; S. Hancock, SPE, RPS Group; C. Santamarina, Georgia Institute of Technology; R. Boswell, US Department of Energy; T. Kneafsey, J. Rutqvist and M. B. Kowalsky, Lawrence Berkeley National Laboratory; M.T. Reagan, SPE, Lawrence Berkeley National Laboratory; E.D. Sloan, SPE, Colorado School of Mines; A.K. Sum and C. A. Koh, Colorado School of Mines

## Abstract

The current paper complements the Moridis et al. (2009) review of the status of the effort toward commercial gas production from hydrates. We aim to describe the concept of the gas hydrate petroleum system, to discuss advances, requirements and suggested practices in gas hydrate (GH) prospecting and GH deposit characterization, and to review the associated technical, economic and environmental challenges and uncertainties, including: the accurate assessment of producible fractions of the GH resource, the development of methodologies for identifying suitable production targets, the sampling of hydrate-bearing sediments and sample analysis, the analysis and interpretation of geophysical surveys of GH reservoirs, well testing methods and interpretation of the results, geomechanical and reservoir/well stability concerns, well design, operation and installation, field operations and extending production beyond sand-dominated GH reservoirs, monitoring production and geomechanical stability, laboratory investigations, fundamental knowledge of hydrate behavior, the economics of commercial gas production from hydrates, and the associated environmental concerns.

## Introduction

**Background.** Gas hydrates (GH) are solid crystalline compounds of water and gaseous substances described by the general chemical formula  $G \cdot N_H \text{H}_2\text{O}$ , in which the molecules of gas  $G$  (referred to as guests) occupy voids within the lattices of ice-like crystal structures. Gas hydrate deposits occur in two distinctly different geographic settings where the necessary conditions of low temperature  $T$  and high pressure  $P$  exist for their formation and stability: in the Arctic (typically in association with permafrost) and in deep ocean sediments (Kvenvolden, 1988).

The majority of naturally occurring hydrocarbon gas hydrates contain  $\text{CH}_4$  in overwhelming abundance. Simple  $\text{CH}_4$ -hydrates concentrate methane volumetrically by a factor of  $\sim 164$  when compared to standard  $P$  and  $T$  conditions (STP). Natural  $\text{CH}_4$ -hydrates crystallize mostly in the structure I form, which has a hydration number  $N_H$  ranging from 5.77 to 7.4, with  $N_H = 6$  being the average hydration number and  $N_H = 5.75$  corresponding to complete hydration (Sloan and Koh, 2008). Natural GH can also contain other hydrocarbons (alkanes  $\text{C}_\nu\text{H}_{2\nu+2}$ ,  $\nu = 2$  to 4), but may also contain trace amounts of other gases (mainly  $\text{CO}_2$ ,  $\text{H}_2\text{S}$  or  $\text{N}_2$ ).

Although there has been no systematic effort to map and evaluate this resource on a global scale, and current estimates of in-place volumes vary widely (ranging between  $10^{15}$  to  $10^{18}$   $\text{m}^3$  at standard conditions), the consensus is that the worldwide quantity of hydrocarbon within GH is vast (Milkov, 2004; Boswell and Collett, 2010). Given the sheer magnitude of the resource, ever increasing global energy demand, and the finite volume of conventional fossil fuel resources, GH are emerging as a potential energy source for a growing number of nations. The attractiveness of GH is further enhanced by the environmental desirability of natural gas, as it has the lowest carbon intensity of all fossil fuels. Thus, the appeal of GH accumulations as future hydrocarbon gas sources is rapidly increasing and their production potential clearly demands technical and economic evaluation. The past decade has seen a marked acceleration in gas hydrate R&D, including both a proliferation of basic scientific endeavors as well as the strong emergence of focused field studies of GH occurrence and resource potential, primarily within national GH programs (Paul et al., 2010). Together, these efforts have helped to clarify the dominant issues and challenges facing the extraction of methane from gas hydrates.

A review paper by Moridis et al. (2009) summarized the status of the effort for production from gas hydrates. The authors discussed the distribution of natural gas hydrate accumulations, the status of the primary international research and development R&D programs (including current policies, focus and priorities), and the remaining science and technological challenges facing commercialization of production. After a brief examination of GH accumulations that are well characterized and appear to be models for future development and gas production, they analyzed the role of numerical simulation in the assessment of the hydrate production potential, identified the data needs for reliable predictions, evaluated the status of knowledge with regard to these needs, discussed knowledge gaps and their impact, and reached the conclusion that the numerical simulation capabilities are quite advanced and that the related gaps are either not significant or are being addressed. Furthermore, Moridis et al. (2009) reviewed the current body of literature relevant to potential productivity from different types of GH deposits, and determined that there are consistent indications of a large production potential at high rates over long periods from a wide variety of GH deposits. Finally, they identified (a) features, conditions, geology and techniques that are desirable in the selection of potential production targets, (b) methods to maximize production, and (c) some of the conditions and characteristics that render certain GH deposits undesirable for production.

**Objectives.** The current paper complements the Moridis et al. (2009) review of the status of the effort toward commercial gas production from GH. Its objectives are to describe the concept of the gas hydrate petroleum system, to discuss advances, and suggested practices in GH prospecting and GH deposit characterization, and to review the challenges and uncertainties facing commercial gas production from hydrates. These challenges touch upon technical, economic and environmental issues, and include (1) the assessment of in-place vs. producible fractions of the GH resource, (2) the development and evaluation of methodologies for identifying suitable production targets, (3) the sampling of hydrate-bearing sediments, sample analysis, and interpretation of results, (4) the analysis and interpretation of geophysical surveys of GH reservoirs, (5) well testing methods and interpretation of the results, (6) geomechanical and reservoir/well stability concerns in the course of gas production, (7) well design, operation and installation appropriate for the particularities of GH systems, (8) field operations of production, (9) extending production beyond sand-dominated GH reservoirs, (10) monitoring production and geomechanical stability, (11) laboratory investigations and practices in support of gas production analysis, (12) fundamental knowledge of hydrate behavior, (12) the economics of commercial gas production from hydrates, and (13) the associated environmental concerns.

**Classification of Gas Hydrate Deposits and Production Methods.** Natural GH accumulations are divided into three main classes (Moridis and Collett, 2003) based on simple geologic features and the initial reservoir conditions. Class 1 settings are composed of two layers: a Hydrate-Bearing Layer (HBL) and an underlying two-phase fluid zone of mobile gas and liquid water. Because the base of the gas-hydrate stability zone (BGHSZ) coincides with the bottom of the HBL, this is the most desirable system as it requires the least energy input to initiate gas release (Moridis et al., 2007; 2009). Class 2 settings comprise an HBL overlying a zone of mobile water. Class 3 accumulations are composed of a single HBL, and are characterized by the absence of an underlying zone of mobile fluids. In Classes 2 and 3, the entire HBL may be at the base of, or well within, the hydrate stability zone. A fourth class (Class 4) is typical of many oceanic accumulations, and involves disperse, low-saturation hydrate (<10%) deposits that lack confining geologic strata and are not promising targets for production (Moridis and Sloan, 2007).

Gas can be produced from GH by inducing dissociation by one of the following main methods (Makogon, 1997): (1) depressurization, in which the pressure  $P$  is lowered to a level lower than the hydration pressure  $P_e$  at the prevailing temperature  $T$ , (2) thermal stimulation, in which  $T$  is raised above the hydration temperature  $T_e$  at the prevailing  $P$ , and (3) the use of inhibitors (such as salts and alcohols), which shifts the  $P_e$ - $T_e$  equilibrium. Long-term production strategies often involve combinations of the three main dissociation methods (Moridis and Reagan, 2007a,b). Another production method involves  $\text{CH}_4$  exchange with another hydrate-forming gas (e.g.,  $\text{CO}_2$ ) through a thermodynamically favorable reaction (White and McGrail, 2008; Graue et al., 2008).

### Uncertainties and Challenges Related to Gas Hydrate Energy Assessments

Although the literature is replete with references to the enormity of the volumes of gas in geologic hydrate deposits (Sloan and Koh, 2008) that is estimated to rival (and probably exceed) the volumes within the currently-producing suite of natural gas resources, it is important to note that none of the published worldwide GH assessments have predicted how much gas could actually be produced from gas hydrates. Much more work is needed to address this challenge, both by (a) constraining realistic *in-place* GH volumetric estimates, (b) conducting specific assessments of resources within the most promising accumulation types, and, (c) combining these estimates with data from field tests and numerical simulations to estimate technically and commercially producible volumes.

In the U.S., GH volumetric estimates have been conducted at both the “national” and “sedimentary basin” scale. The 1995 National Assessment of United States Oil and Gas Resources conducted by the U.S. Geological Survey (USGS) included for the first time a systematic appraisal of the *in-place* natural GH resources of the U.S. onshore and offshore regions (Collett, 1995). Eleven GH plays were identified within four offshore provinces and one onshore gas hydrate province. The offshore GH provinces lie within the U.S. Exclusive Economic Zone (EEZ) adjacent to the lower 48 States and Alaska. The only onshore province assessed was the North Slope of Alaska. *In-place* gas resources within the gas hydrates of the United States are estimated to range from about 3,200 to 19,000 trillion cubic meters of gas (~113,007 to 670,979 trillion cubic feet), at the 0.95 and 0.05 probability levels, respectively. Although this wide range of values shows a high degree of uncertainty, it does indicate that enormous quantities of gas are stored within gas hydrates. The mean *in-place* value for the entire United States was calculated to be about 9,000 trillion  $\text{m}^3$  of gas (~317,832 trillion  $\text{ft}^3$ ).

More recently, the U.S. Minerals Management Service (MMS) conducted a systematic geological and statistical assessment of *in-place* GH resources in the Gulf of Mexico sedimentary basin (Frye, 2008). This assessment integrated the latest findings regarding the geological controls on the GH occurrence and the abundant geological and geophysical data from the Gulf of Mexico (Figure 1). The MMS gas hydrate assessment model was developed using a mass balance approach, with the GH volume in each model cell being calculated using stochastic modeling. The *in-place* volume of undiscovered gas estimated within the gas hydrates of the Gulf of Mexico was reported as a cumulative probability distribution, with a mean volume estimate of 607 trillion  $\text{m}^3$  (~21,436 trillion  $\text{ft}^3$ ). In addition, the assessment reported that 190 trillion  $\text{m}^3$  (~6,710 trillion  $\text{ft}^3$ ) of this mean estimate are in highly concentrated accumulations within sand reservoirs, with the remainder in clay-dominated sediments.

In late 2008, the USGS completed the first regional assessment of the undiscovered technically recoverable GH resources yet produced. This study, which focuses on the North Slope of Alaska (Collett et al., 2008), indicates the existence of GH resources that can be discovered, developed, and produced by using current technology. This assessment is based on the geologic elements used to define a Total Petroleum System (TPS), including hydrocarbon source rocks (source-rock type and maturation and hydrocarbon generation and migration), reservoir rocks (sequence stratigraphy, petrophysical properties, seismic attribute development, and prospecting), and hydrocarbon traps (trap formation and timing). The area assessed in northern Alaska (Figure 2) extends from the National Petroleum Reserve in Alaska (NPR) on the west through the Arctic National Wildlife Refuge (ANWR) on the east, and from the Brooks Range northward to the State-Federal offshore boundary (located ~4.8 km north of the coastline). This area consists mostly of Federal, State, and Native lands covering 114,765 km<sup>2</sup>. For the first time, the USGS has assessed gas hydrates, an “unconventional resource” with no confirmed production history, as a producible resource in discrete hydrocarbon traps and structures. The approach used to assess the GH resources in northern Alaska followed standard geology-based USGS assessment methodologies that have been developed to assess conventional oil and gas resources. In order to use this approach on GH resources, it was documented through the analysis of three-dimensional industry-acquired seismic data, that the gas hydrates on the North Slope occupy limited but discrete volumes of rock bounded by faults and down-dip water contacts. The USGS conventional assessment approach also assumes that the hydrocarbon resource being assessed can be produced by existing conventional technology. The production potential of the known and seismically inferred GH accumulations in northern Alaska has not been adequately field tested, but has been the focus of a U.S. Department of Energy (DOE) research effort. Although verified by only limited field tests, numerical production models of GH-bearing reservoirs suggest that gas can be produced from gas hydrate with existing conventional technology (Anderson et al., 2008). Using a geology-based assessment methodology, the USGS estimated the total undiscovered technically recoverable natural gas resources in gas hydrates in northern Alaska to be between 0.71 and 4.47 trillion m<sup>3</sup> (~25.2 and 157.8 trillion ft<sup>3</sup>) (95% and 5% probabilities of greater than these amounts, respectively), with a mean estimate of 2.42 trillion m<sup>3</sup> (~85.4 trillion ft<sup>3</sup>).

### The Concept of the Gas Hydrate Petroleum System

In recent years, significant progress has been made in addressing key issues on the formation, occurrence, and stability of gas hydrate in nature. The concept of a GH petroleum system, similar to that which guides current conventional oil and gas exploration, is gaining acceptance (Collett et al., 2009). In a gas hydrate petroleum system, the individual factors that contribute to the formation of gas hydrate can be identified and assessed; the most important include (1) GH pressure-temperature stability conditions, (2) gas source, (3) gas migration, and (4) suitable host sediment or “reservoir”. In the following discussion, these geologic controls on the stability and formation of gas hydrate in nature will be reviewed and evaluated.

**Gas Hydrate Stability Conditions.** Gas hydrates exist under a limited range of temperature and pressure conditions such that the depth and thickness of the zone of potential GH stability can be calculated given information on  $T$ ,  $P$ , and gas and formation water chemistry. Depicted in the  $T$  vs. depth plot in Figure 3 are a series of subsurface temperature profiles from an onshore permafrost area and two laboratory-derived gas hydrate stability curves for different natural gases (modified from Holder et al., 1987). This phase diagram illustrates how variations in formation  $T$ , pore  $P$ , and gas composition can affect the thickness of the GH stability zone. In this example, the mean annual surface  $T$  is assumed to be -10°C; however, the depth to the base of permafrost (0°C isotherm) is varied for three example  $T$  profiles (permafrost depths of 305 m, 610 m, and 914 m). Below permafrost, three different example geothermal gradients (0.04°C/m, 0.032°C/m, and 0.02°C/m) are used to project the sub-permafrost  $T$  profiles. The two gas-hydrate stability curves represent different gas chemistries. One of the stability curves is for a 100% CH<sub>4</sub>-hydrate, and the other is for a hydrate that contains 98% methane, 1.5% ethane, and 0.5% propane. This example phase diagram is constructed assuming a hydrostatic pore-pressure gradient of 9.795 kPa/m (0.433 psi/ft).

The zone of potential GH stability in the phase diagram (Figure 3) lies within the depths between the two intersections of the geothermal gradient and the gas-hydrate stability curve. For example, in Figure 1, the temperature profile projected to an assumed permafrost base of 610 m intersects the 100% CH<sub>4</sub>-hydrate stability curve at about 200 m, thus marking the upper boundary of the methane-hydrate stability zone. Most GH stability studies assume a hydrostatic pore-pressure gradient (reviewed by Collett, 2002). A geothermal gradient of 0.04°C/m projected from the base of permafrost at 610 m intersects the 100% methane-hydrate stability curve at about 1,100 m; thus, the zone of potential methane-hydrate stability is approximately 900 m thick. However, if the permafrost extended to a depth of 914 m, and if the geothermal gradient below permafrost is 0.02°C/m, the zone of potential CH<sub>4</sub>-hydrate stability would be approximately 2,100 m thick. The addition of 1.5% ethane and 0.5% propane to the pure CH<sub>4</sub> gas system shifts the stability curve to the right, thus deepening the zone of potential GH stability. Additionally, higher pore fluid salinity lowers the temperature at which GHs form.

**Gas Source.** The availability of large quantities of hydrocarbon gas from both microbial and thermogenic sources are an important factor controlling the formation and distribution of natural GHs (Collett, 1993; Kvenvolden, 1993; Collett, 2002; Collett et al., 2008a). Carbon isotope analyses indicate that the methane in many oceanic hydrates is derived from microbial sources; however, thermal sources have been observed within several GH occurrences in the Gulf of Mexico, Caspian Sea, Black Sea, and onshore in the Mackenzie Delta and northern Alaska (Collett, 2002). Recent studies in northern Alaska

(Collett et al., 2008a) and Canada (Dallimore and Collett, 2005) have again documented the importance of thermogenic gas sources to the formation of highly concentrated GH accumulations.

**Gas Migration.** A highly concentrated GH accumulation contains a substantial volume of gas, which is potentially derived from microbial and/or thermogenic sources. Typically, not enough microbial methane is generated internally within the GH stability zone alone to account for the gas content of most hydrate accumulations (Kvenvolden, 1993). In addition, most GH accumulations are in sediments that have not been deeply buried or subjected to temperatures sufficiently elevated to form thermogenic gas. Thus, the gas within most hydrate accumulations is likely concentrated in the hydrate stability zone by a potential combination of processes — one of which, gas migration, would appear to be a critical component within most GH petroleum systems.

Methane, along with other hydrate forming gases, migrates within a sedimentary section by one of three processes: (1) diffusion, (2) dissolution into migrating water, or (3) as a bubble — a separate gas phase. Migration of gas by diffusion is a slow process and would not likely result in the movement of enough gas to form a concentrated GH accumulation (Xu and Ruppel, 1999). However, the migration of gas by advection as either a dissolved component in water or as a separate gas phase can be a highly efficient process.

Two basic models have been proposed to describe the interrelation between advective gas migration and GH formation. In a model originally proposed by Hyndman and Davis (1992), water (with a dissolved aqueous phase of methane and other potential hydrate formers) moving upward into the hydrate zone encounters decreasing methane solubility, which results in the exsolution of  $\text{CH}_4$  and GH formation. The other basic model for GH formation in sediments involves the upward migration of  $\text{CH}_4$  as a bubble phase (separate gas phase) into the hydrate stability zone, with hydrate nucleation taking place at the bubble and pore-water interface. Both models require permeable pathways to allow for the migration of water and/or a gas phase (i.e., bubble), but the gas-phase migration model requires relatively enhanced fluid flow pathways in comparison to the aqueous migration model. It is generally concluded that both pore-water flow and bubble gas phase migration in sediments are focused along permeable pathways such as fault systems or coarser-grained sediment layers. Therefore, if effective migration pathways are not available, it is unlikely that a significant GH volume would accumulate.

**Reservoir Rocks.** The study of gas-hydrate samples indicates that the physical nature of in-situ GHs is highly variable (Sloan and Koh, 2008). Gas hydrates are observed (1) occupying pores of coarse-grained sediment; (2) as nodules disseminated within fine-grained sediment; (3) as a solid substance, filling fractures; or (4) as massive units composed mainly of solid GH with minor amounts of sediment. Most GH field expeditions, however, have shown that the occurrence of a elevated (greater than ~10 to 20% of pore space) hydrate saturation  $S_H$  within sediments is mostly controlled by the presence of fractures and/or coarser grained sediments in which gas hydrate fills fractures or is disseminated in the pores of sand-rich reservoirs (Collett, 1993; Dallimore and Collett, 2005; Riedel et al., 2006a; Collett et al., 2008a, 2008b; Park et al., 2008; Yang et al., 2008). Torres et al. (2008) concluded that hydrate grows preferentially in coarse-grained sediments because lower capillary pressure,  $P_{cap}$ , in these sediments permits the migration of gas and nucleation of hydrate. The growth of gas hydrate in clay-rich sediments, however, is less understood. By all accounts, GHs in arctic permafrost regions occur at high  $S_H$  in sand-dominated reservoirs (Collett, 1993; Dallimore and Collett, 2005), which have been the focus of GH exploration and production studies in northern Alaska.

GH occurs in all varieties in the marine environment. Marine GH-bearing sand reservoirs have been documented from the Nankai Trough (Fujii et al., 2008), the Cascadia Margin (Riedel et al., 2006a) and from the Gulf of Mexico (Boswell et al., 2009, 2010). Thick sequences of fractured marine clays are likely very common, having been recently documented in the Gulf of Mexico (Cook et al., 2008); India (Collett et al., 2008a); and offshore Korea (Park et al., 2008). Pore-filling GH in fine-grained sediments are widespread in the marine environment, and may represent the largest share of the total global GH resource: examples include the Blake Ridge offshore the Carolinas (Paull et al., 1995) and offshore China (Yang et al., 2008).

Production testing and modeling has shown that high- $S_H$  GH occurrences in sand reservoirs are conducive to existing well-based production technologies (Moridis et al., 2007; Moridis and Reagan, 2007a,b; Anderson et al., 2010; Dallimore et al., 2008a, 2008b; Moridis et al., 2008; Yamamoto and Dallimore, 2008). For both arctic and marine hydrate-bearing sand reservoirs, there are no apparent technical roadblocks to resource extraction (CADOEMHRD, 2010); the remaining resource issues deal mostly with the economics of gas production.

### Gas Hydrate Prospecting and Geologic Characterization

As previously indicated, GH occurs in two environments: deep marine and onshore arctic. The presence of GH in offshore continental margins has historically been inferred from anomalous seismic reflectors that coincide with the BGHSZ (Kvenvolden, 1993; Collett, 2002). This reflector is commonly called a bottom-simulating reflector (BSR). The BSR is usually interpreted to mark the boundary between hydrate-bearing sediments (HBS) and underlying free-gas-bearing sediments, although this is occasionally not the case where geologic history and gas geochemistry are complex (Hadley et al., 2008). This boundary creates a strong acoustic impedance contrast on recorded seismic lines. Because the BSR follows the BGHSZ, generally at a constant depth below the seafloor, the bright reflector with a polarity opposite to the seafloor typically cuts across bedding planes and mimics the seafloor topography (hence the name ‘bottom-simulating’ reflector). Such continuous, or “classical” BSRs, however, are just one of several seismic manifestations of the base of gas hydrate stability

observed in marine environment (Shedd et al., 2009). Geophysically inferred horizons representing the BGHS have been observed at depths as great as 1,100 m below the sea floor (McConnell and Kendall, 2002).

Recently, a growing number of deep sea drilling expeditions have been dedicated to locating marine GHs and obtaining a greater understanding of the geologic controls on their occurrence. The earliest projects have been those of the Ocean Drilling Program (ODP) and the Integrated Ocean Drilling Program (IODP). ODP Legs 141 (Lewis et al., 1995) and 146 (Carson et al., 1995) were the earliest expeditions to drill through the BSR. Additional early expeditions included ODP legs 164 (Paull et al., 1996) and 204 (Tréhu et al., 2004), IODP Expedition 311 (Riedel et al., 2006a), as well as the 1998 and 2005 drilling programs conducted in the Nankai trough by the MH21 consortium (Tsujii et al., 2009; Fujii et al., 2008). More recently, GH drilling projects such as the Gumusut-Kakap project offshore Malaysia (Hadley et al., 2008), the DOE-sponsored drilling Legs I and II under the Joint-Industry Project in the Gulf of Mexico (Ruppel et al., 2008; Boswell et al., 2010), and the India NGHP Expedition 01 (Collett et al., 2008b, 2008c, 2008d), as well as those in the offshore of China (Yang et al., 2008) and South Korea (Park et al., 2008) have continued to expand the GH knowledge base.

Gas hydrates in onshore arctic environments are closely associated with permafrost. It is generally believed that thermal conditions conducive to the formation of permafrost and GH have persisted in the Arctic since the end of the Pliocene (1.9 Mya) (Collett, 2002). The combined information from Arctic gas-hydrate studies shows that, in permafrost regions, GHs may exist at subsurface depths ranging from about 130 m to 2,000 m.

Recent advancements in GH prospecting involve an integrated approach combining seismic and electromagnetic methods. Evaluation of industry-standard 3D seismic data has enabled evaluation of gas hydrate prospects later validated by drilling both in Alaska (Inks et al., 2009; Lee et al., 2010) and in the Gulf of Mexico (Shelander et al., 2010; Boswell et al., 2010a). Several studies have shown that multi-component seismic technology is able to broaden our knowledge of the gas hydrate reservoir (Sava and Hardage, 2009; Hardage et al., 2009). In the marine environment shear waves (S-waves) can be generated by conversion from a downward-propagating compressional wave (P-wave) upon reflection at a sedimentary interface. The integration of shear and compressional wave seismic data has allowed for the more accurate estimations of gas hydrate and free gas concentrations and to assess the occurrence of overpressures within the gas-bearing sediments beneath hydrates. Marine electromagnetic (EM) surveys also show promise as a new technique for characterizing and quantifying the occurrence of seafloor gas hydrates (Edwards, 1997; Riedel et al., 2006b; Scholl et al., 2008; Weitemeyer and Constable, 2009; U.S. DOE, 2010), and have been used to conduct studies in the Gulf of Mexico (see next section). EM methods are sensitive to the concentration and geometric distribution of hydrate, but the use of marine EM techniques to characterize hydrate is still in its infancy. Field trials carried out to date have been limited in scope and sophistication, and there is a lack of laboratory-derived relationships between petrophysical properties and EM measurements on which to relate conductivity to quantitative estimates of hydrate volume in the seafloor section (Weitemeyer and Constable, 2009; U.S. DOE, 2010).

Reliable estimates of the energy resource potential of GH deposits rely on the development and use of a combination of complex geological, geophysical, petrophysical and reservoir engineering assessment techniques. This evaluation is performed in stages; the results from each stage determine whether or not the next stage is justified. In the first stage, new advanced geological and geophysical techniques have been developed to identify and characterize potential hydrate-bearing reservoirs. Next, drilling of exploration wells and conducting well tests confirms the presence of the GH reservoirs, enables the determination of the type and size of the hydrate accumulation, and provides direct measurements of the system hydraulic properties and its response to a pressure regime imposed at the well, as well as parameter estimates obtained from history matching of the measured system behavior. Finally, with the data obtained in the first two stages, numerical simulation provides estimates of the gas production potential of the reservoirs, which can serve as a valuable tool before full-scale production is attempted. The two best examples of this type of integrated GH exploration approach can be found in the Mount Elbert project on the North Slope of Alaska (Boswell et al., 2010b) and the recent prospecting and drilling efforts conducted under Leg II of the Gulf of Mexico Joint Industry GH project (Boswell et al., 2010a).

### **Methodology For Identifying Suitable Hydrate Deposits as Production Targets**

In 2003, the USGS initiated a study to develop seismic interpretive methods to identify and characterize GH accumulations in northern Alaska. This study dealt primarily with the analysis of a 3-D seismic data set from the area of the Milne Point Field as provided to the USGS by BP Exploration Alaska, Inc. (Figure 4). Detailed analysis and interpretation of available 3-D and 2-D seismic data sets, along with seismic modeling and correlation with specially processed downhole well log data, has led to the development of a viable method for identifying sub-permafrost GH prospects within the gas hydrate stability zone in the Milne Point area (Lee et al., 2010; Inks et al., 2009).

**Mount Elbert project on the North Slope of Alaska.** In 2003, the USGS initiated a study to develop seismic interpretive methods to identify and characterize GH accumulations in northern Alaska. This study dealt primarily with the analysis of a 3-D seismic data set from the area of the Milne Point Field as provided to the USGS by BP Exploration Alaska, Inc. (Figure 4). Detailed analysis and interpretation of available 3-D and 2-D seismic data sets, along with seismic modeling and correlation with specially processed downhole well log data, has led to the development of a viable method for identifying sub-permafrost GH prospects within the gas hydrate stability zone in the Milne Point area (Lee et al., 2009, 2010; Inks et al., 2009).

Initial seismic interpretation indicated a range of potential GH prospects including accumulations at the base of the gas hydrate stability zone (in contact with underlying free gas) and those higher in the stratigraphic section. However, well log data showed that the gas hydrate and free gas saturations in these deeper reservoirs were low due to leaky seals or inadequate charge (Inks et al., 2009). In 2005, the project team completed their delineation, description, and ranking (including probabilistic volumetrics) of 14 gas hydrate prospects within the Milne Point area. The seismic characterization of the GH prospects was based on rock physics relationships calibrated with downhole log data from nearby offset wells that enabled the prediction of GH “pay” thickness and hydrate saturation  $S_H$  from analysis of seismic amplitudes and peak-trough travel-times (Lee et al., 2009).

The highest-ranked Milne Point GH prospect was named Mount Elbert. The pre-drill site evaluation predicted that Mount Elbert would contain about ~4.1 billion cubic meters (~145 billion cubic feet) of in-place gas in two reservoir sands, i.e., units C and D (Collett, 1993; Inks et al., 2009). The Mount Elbert prospect, like all of the most promising Milne Point prospects, had not been penetrated by existing wells. Therefore, it was decided to drill a stratigraphic test well to confirm reservoir occurrence, ground-truth the prospecting and assessment methodologies, and enable the collection of additional reservoir data to support reservoir simulation modeling and production test design (Boswell et al., 2010b).

The Mount Elbert gas hydrate stratigraphic test well acquired sediment cores, well logs, and downhole production test data. Gas hydrates were expected and found in two stratigraphic zones — an upper zone containing about 45 ft of GH-bearing reservoir-quality sandstone, and a lower zone containing about 50 ft of GH-bearing reservoir (Figure 5). Both zones displayed  $S_H$  levels that varied with reservoir quality, with typical values between 60% and 75% (Lee and Collett, 2010). This result conclusively demonstrated the soundness of the GH prospecting methods developed primarily at the USGS. Evaluations of the production potential of the Mount Elbert deposits by means of numerical simulation were conducted by Rutqvist et al. (2009) and Moridis et al. (2010) and were enabled by evaluation of field pressure transient test data collection and analysis (Anderson et al., 2010).

**Gulf of Mexico Joint Industry gas hydrate project.** One of the most comprehensive studies of marine GHs is underway in the Gulf of Mexico within a Joint Industry Project (JIP) led by Chevron in partnership with the U.S. Department of Energy. On May 6, 2009, the JIP, including DOE, USGS, and MMS research scientists, completed the first-ever drilling project with the expressed goal to collect geologic data on gas-hydrate-bearing sand reservoirs in the Gulf of Mexico. This was an important goal because other resource assessment studies in northern Alaska by the USGS (Collett et al., 2008) and offshore Japan (Fujii et al., 2008; Kurihara et al., 2010), have shown that GHs in sand reservoirs are likely the closest to potential commercialization. In 2005, the Gulf of Mexico Gas Hydrate JIP Leg I conducted drilling, coring, and downhole logging operations designed primarily to assess GH-related hazards associated with drilling through the clay-dominated sediments that typify the shallow sub-seafloor in the deepwater Gulf of Mexico (Ruppel et al., 2008). Upon analysis of Leg I results, the JIP membership decided to expand its effort to assess issues related to the occurrence of GH within coarser-grained sediments. To develop suitable GH drilling targets for the next expedition, geoscientists from the USGS, the DOE’s National Energy Technology Laboratory (NETL), the MMS, AOA Geophysics, the Naval Research Lab, and Rice University collaborated to evaluate and prioritize various prospects with respect to the potential of encountering high concentrations of GH in sand reservoirs (Hutchinson et al., 2008). The group evaluated these sites through integrated geological and geophysical analyses and ultimately developed the site descriptions and prioritizations that were implemented in JIP Leg II. This analysis also included the use of advanced seismic inversion techniques to estimate GH saturations at the drill sites being considered (Dai et al., 2008; Shelandar et al., 2010).

JIP Leg II featured the collection of a comprehensive set of logging-while-drilling (LWD) data through expected gas-hydrate-bearing sand reservoirs in seven wells at three locations in the Gulf of Mexico (Figure 6). The semi-submersible drilling vessel Helix Q4000 was mobilized at sea in the Gulf Mexico and drilling was conducted in the Walker Ridge, Green Canyon and the Alaminos Canyon blocks (Collett et al., 2010). The LWD sensors just above the drill bit provided important new information on the nature of the sediments and the occurrence of gas hydrate (Mrozewski et al., 2010). The full research-level LWD data set on formation lithology, electrical resistivity, acoustic velocity, and sediment porosity  $\phi$  enabled the greatly improved evaluation of GH in both sand and fracture dominated reservoirs.

The two holes drilled at Walker Ridge 313 yielded evidence of a laterally continuous thick fracture-filling gas hydrate section, but more importantly both wells also encountered sand reservoirs, between 40- to 50-ft-thick, highly saturated with GH (Shedd et al., 2010). Gas-hydrate-bearing sands were also drilled in two of the Green Canyon 955 wells, with one occurrence approximately 100-ft-thick (McConnell et al., 2010). Initial interpretation of the Alaminos Canyon 21 drilling results is that the sands appear to exhibit uniformly low-to-moderate hydrate saturation  $S_H$  over a large area (Frye et al., 2010). Of the 7 wells drilled, 6 encountered gas hydrates in close agreement with the pre-drill predictions. These results validate the approach that integrates direct seismic detection/assessment with geological-geophysical prospecting concepts based on full petroleum systems analysis, and provides increased confidence in existing assessments of GH volumes in the Gulf of Mexico and other marine sedimentary basins.

### **Challenges in the Analysis and Interpretation of Geophysical Surveys**

The extraction of information on the properties of HBS, in particular  $S_H$  from geophysical surveys is discussed authoritatively by Dai et al., (2004), Bellefleur et al. (2006), Dvorkin and Uden (2006), Hardage et al. (2006), and many others, as is fully

explored in a series of papers included in Riedel et al. (in press). In general, current experience indicates that GH exploration is fairly well advanced when assessing deep deposits at high  $S_H$ , but challenges remain with respect to hydrates at low saturations. Fracture-filling occurrences are also challenging to interpret with acoustic data, but may be amenable to analysis using EM surveys (Constable et al., 2006). The well-log analysis following the 2002 Mallik Test (Anderson et al., 2005; Collett and Lee, 2005; Collett et al., 2005; Guerin et al., 2005; Kleinberg et al., 2005; Lee and Collett, 2005; Milkereit, 2005; Plona and Kane, 2005; Sun and Goldberg, 2005; Takayama et al., 2005) still represents the state of the art in this subject. In log analysis, the approach appears to be well established for pore-filling gas hydrates, but for grain-displacing, clay-hosted hydrates, the collection of multi-azimuth resistivity and use of methods beyond Archie's Law is a new development in need of further calibration (Worthington, 2009; Lee and Collett, 2009).

The current bottleneck in the state-of-practice of geophysical analysis is centered on the relationship between measured physical parameters and  $S_H$  (Waite et al., 2010; Santamarina and Ruppel, 2010; Lee et al., 2010a; Lee et al., 2010b), in particular:

- Electrical conductivity and Archie's Law: most applications use empirical and fitting parameters, leading to good fits to the data but uncertain predictions, particularly in the absence of accurate information on the electrical conductivity of the pore fluid in situ (Edwards, 1997; Riedel et al., 2006b; Scholl et al., 2008; Weitemeyer and Constable, 2009; U.S. DOE, 2010).
- P-wave velocity data – Biot-Gassman. The constrained modulus is strongly affected by the stiffness of the pore fluid, leading to potential error magnification in the assessment of  $S_H$  from  $V_p$ . However, the complexity of mixed-system acoustics and grain/pore fluid interactions may be an even more important issue (Lee and Waite, 2008).
- S-wave velocity properly detects the effect of hydrates on the shear stiffness of the granular skeleton, which depends both on  $S_H$  and pore habit: there is almost no effect if  $S_H$  is low and hydrate is within the pore space, i.e., when it nucleates on mineral surfaces from dissolved gas; there is significant effect when hydrate forms from gas phase at interparticle contacts even if  $S_H$  is low; finally, hydrate contributes new contacts to the granular structure at high hydrate saturation ( $S_H \gg 0.4$ ). When using S-wave data, proper constitutive models are needed for effective stress-dependent sediment shear stiffness and to account for the impact of hydrate on skeletal stiffness.
- Permittivity in the microwave frequency range can be a reliable parameter for the determination of the volumetric fraction of unfrozen water, but, on current evidence, this is case-dependent and only the vertical resolution is improved.

Laboratory-scale measurements (see later discussion) are typically conducted on homogeneous specimens, and using high frequency and short-wavelengths. Under these conditions, we have developed good understanding of the effect of *distributed hydrate* on the properties of hydrate-bearing sediments (including the effect of different pore habits). However, as indicated earlier, hydrate is also found in the form of segregated lenses and nodules, with separation length scales in the order of  $<10^{-2}$  m to  $>1$  m, which interacts with the length scale of most borehole measurements. Therefore, laboratory-scale, borehole scale and remote geophysical measurements are all conducted at different frequencies and wavelengths, hence they sense different temporal and spatial conditions, and caution is advised in the interpretation of measurements.

Most of the challenges related to the analysis and interpretation of geophysical surveys that were discussed in this section correspond to borehole studies. An even bigger challenge is the need to expand to integrated geophysical analyses that include multicomponent ( $V_p$  and  $V_s$ ) seismic surveys (Sava and Hardage, 2009; Hardage et al., 2009), in combination with promising EM techniques (Edwards, 1997; Riedel et al., 2006b; Scholl et al., 2008; Weitemeyer and Constable, 2009; U.S. DOE, 2010).

### Challenges in Sampling and Sample Analysis

Sediment sampling and the interpretation of properties measured using samples are among the most challenging tasks in ge-engineering (Paul et al. 2010). Gas hydrate expeditions have increasingly featured comprehensive pressure-coring programs (Schultheiss et al., 2009) that enable analysis of the physical properties of HBS. To provide the most reliable results, a sample is expected (1) to represent the sediment constitution (grain size, mineralogy and fluids), (2) to capture the statistics of the sediment characteristics (mean, variation and spatial variability), and (3) to preserve its physical properties (porosity and fabric, as well as all forms of hydro-chemo-thermo-bio-mechanical properties). Unfortunately, most of these characteristics are seriously compromised in the sampling of HBS. Processes involved during sampling are briefly discussed next:

- The sampling of any sediment suffers from profound sampling effects due to unavoidable changes in effective stress and ensuing strains: disturbance due to coring tools, relaxation of the *in-situ* effective stress, shear along sampler or liner walls; further relaxation and alteration take place as the specimen is recovered from the core liner, trimmed, and re-stressed within triaxial or oedometric cells (Lunne et al., 2006).
- Hydrate dissolution and eventual dissociation aggravate the previous effects. The volume occupied by the hydrate mass expands several times as hydrate dissociates into water+gas; gas-driven fractures form in low fluid conductivity sediments; both gas and water fill pores, give rise to capillary effects; the released hydrate-forming water freshens the pore fluid (i.e., lower ionic concentration).
- Most hydrate in fine-grained sediments is found forming a network of thin lenses (Note: some of these features may themselves be the consequence of sampling). The separation of these features appears to be on the order of mm-to-m;

therefore, the scale of hydrate distribution interacts with sampling and testing scales, and hinders characterization (implications on thermal properties are discussed in Cortes et al., 2009).

These processes critically affect all physical properties. The main challenge for the analyst is to properly interpret laboratory data and to recover meaningful information needed for numerical simulators and engineering design. There are several initiatives to overcome or circumvent these difficulties:

- A research team at the Georgia Institute of Technology has developed capabilities for pressure core testing to characterize hydrate-bearing sediments without ever exposing them outside the PT-stability field (Yun et al., 2006b - Figure 7a). However, the sediment still suffers from other mechanical effects listed above associated to changes in effective stress and the ensuing shear and normal strains. Laboratory results show that the presence of distributed GH stabilizes the granular skeleton when  $S_H$  is high ( $\sim 0.5$  or greater) and unloaded sediments experience minimal mechanical effects (Lee et al., 2010b). Furthermore, a second chamber to bring sediments in pressure cores back to the in-situ state of effective stress so that effective stress-dependent properties can be properly determined has been developed (Figure 7b).
- When properly analyzed, index properties provide valuable information that can be reliably used to determine the bounds of the HBS property values. These index properties include: grain size distribution; the percentage of fines (passing sieve #200), XRD-mineralogy, specific surface, and SEM image analysis; in situ  $\phi$  and  $S_H$ ; and pore fluid salinity. The benefits of this comprehensive approach have been documented for various hydrate-bearing formations: Gulf of Mexico sediments (Francisca et al., 2005; Yun et al., 2006a); Krishna-Godavari Basin sediments (Yun et al., 2010); Ullung Basin sediments (Lee et al., 2010c); and Mount Elbert sediments (Dai et al., 2010).
- The analysis of index properties can be complemented with laboratory compression, strength and geophysical testing of reconstituted sediments including the formation of synthetic hydrate at various levels of  $S_H$  (Gulf of Mexico sediments: Lee et al. (2008); Mount Elbert sediments: Dai et al. (2010); Japanese sediments: Hyodo et al. (2005); Masui et al. (2008).

We can anticipate that further developments in sediment characterization will include more extensive developments in *in situ* testing. Finally, proper formation characterization will combine information gathered using index-property based bounds, reconstituted specimens, pressure cores, and in situ testing data.

### Well Testing and Interpretation Issues

Well testing is a key technique that is widely employed for the purpose of reservoir characterization. Well testing and pressure transient analysis (PTA) techniques are complementary to other characterization techniques as (i) they fill a gap between the small-scale characterization based on cores and logs and large-scale characterization based on geophysical measurements, and (ii) they provide a measure of flow capacity, in contrast to static properties that is found from many other techniques.

In hydrate reservoirs, there are at least three reported cases of pressure transient tests that along with other techniques have been used for reservoir characterization. Significant advances have taken place in testing from the first series of the tests at Mallik in 2002. Additionally, there has been an evolution in the techniques available for interpretation of the test results. Initially, techniques developed for conventional reservoirs were applied, ignoring temperature and phase change effects associated with hydrate dissociation. This was immediately followed by use of numerical simulation techniques, which allows incorporation of the complex physics associated with hydrate dissociation but suffers from the unavailability of several and often-unknown parameters. Recently, an analytical solution specifically for well testing of hydrate reservoirs has been developed. Here we review the progress in well testing and interpretation methodologies for GH reservoirs, and then discuss some of the (many) remaining challenges.

**State of the art.** In this section, we review the well tests that have been conducted on hydrate wells at the Mallik and Mt. Elbert sites, and we discuss some of the theoretical advances that have been developed exclusively for the analysis of well tests in GH reservoirs.

**Mallik MDT Test 2002.** Satoh et al. (2005) and Hancock et al. (2005b) describe the design and operations of the small-scale flow and shut-in tests that were conducted at the 5L-38 research well at Mallik. These tests used the wireline conveyed Modular Formation Dynamic Modular Tester (MDT)<sup>TM</sup> of Schlumberger. An MDT test relies on production of a small volume of reservoir fluid, resulting in pressure reduction, followed up by a shut-in period. Conventionally, the pressure rise during the shut-in period may be analyzed to determine flow properties (in particular the effective permeability  $k_{eff}$ ).

The duration of the tests conducted at Mallik were typically 10's of minutes and up to a few hours, with the total fluid withdrawn of up to 10's cm<sup>3</sup>. One of the objectives of these tests was to examine mobility within a hydrate interval that lies within the satiability zone. Co-presence of a mobile fluid, i.e., the unbound formation water, with the hydrate would allow fluid flow and reduction of pressure *within* the hydrate zone without hydrate dissociation. This is of importance for success of the depressurization technique that relies on dissociating hydrates by reducing the pore pressure within the hydrate zone. In the absence of a mobile fluid, dissociation would only occur on a surface between the dissociated and undissociated zones. The tests demonstrated that gas can be produced from a gas-hydrate interval through the sole use of the depressurization technique. Furthermore, the pressure response indicated flow within the porous medium, implying mobility of the formation



water (Hancock et al., 2005b). Gerami and Pooladi-Darvish (2007a) and Tabatabaie and Pooladi-Darvish (2009) have shown that the rate of gas production by depressurization strongly depends on whether hydrate dissociation occurs over a zone or on a surface, with the former providing substantially larger rate of hydrate dissociation.

Hancock et al. (2005b) reported application of conventional PTA techniques developed for single-phase isothermal well testing to the MDT results. This analysis technique when applied to tests that were conducted on three layers with  $S_H$  of between 60 and 85% within the hydrate stability zone indicated a  $k_{eff}$  of between 0.001 to 0.1 mD. Independent estimation of formation  $k_{eff}$  within the hydrate stability zone using an NMR logging technique has also suggested presence of a mobile fluid of comparable permeability (Kleinberg et al. 2005). The  $k_{eff}$  estimates that were representative of an interconnected fluid phase in the sand-dominated GH formations at Mallik were of significant importance, as they suggested that the simple depressurization technique may be an effective methodology for hydrate dissociation (Yamamoto and Dallimore, 2008).

In addition to estimation of  $k_{eff}$ , the application of the PTA techniques to the MDT results suggested presence of a zone of low permeability (or a no flow boundary) at some distance from the wellbore. Application of conventionally used equation for single-phase flow suggested that the radius of investigation of the tests may be up to 2.5 m. It was suggested that there may be a relation between the boundary effects observed at the end of the tests (i.e. large radii of investigation) and the radius of hydrate dissociation. (Hancock et al. 2005b).

Kurihara et al. (2005) used a gas-hydrate simulator to analyze one of the MDT tests. The results indicated that the effective permeability found from application of the conventional PTA techniques, was in close agreement with an average effective permeability over the dissociation zone. In their comprehensive work, Kurihara et al. (2005) examined the validity of the assumptions used in conventional PTA techniques. These are discussed under “Theoretical Developments.”

**Mount Elbert 2007.** Boswell et al. (2008) described the operation and result of a 22-day field program conducted at the Mt. Elbert #1 well on the Alaska North Slope. This field program included 4 MDT tests ranging from 6 to 12 hours each, and examined the flow and pressure behavior of two hydrate-bearing sands within the hydrate stability zone. One major difference between these tests and MDT tests conducted at Mallik (2002) was that, the Mt. Elbert test was conducted on an openhole interval, allowing a large test interval, a long production time, and a large volume of fluid production, as compared with the Mallik tests that were conducted on a cased-and-perforated interval. The results related to the deeper sand (the C sand), which consisted of three flow and shut-in periods, have been analyzed extensively (Anderson et al., 2008). The last and longest flow and shut-in period lasted approximately 2 and 4.5 hours, respectively (See Figure 8). Total fluid production during the time of the test is estimated to be approximately 25 cm<sup>3</sup> of water and 700 cm<sup>3</sup> of gas at standard conditions.

The first flow period was conducted such that the bottomhole pressure did not drop below the estimated equilibrium pressure at the in-situ conditions. This was done to enable estimation of  $k_{eff}$  to water in the presence of hydrate, without having the complications related to hydrate dissociation. Analysis of this flow and shut-in period using conventional (single-phase) well-testing techniques resulted in a permeability estimate in the range of 0.12 to 0.17 mD. The analysis of the subsequent flow and shut-in periods was with the help of hydrate reservoir simulators. In a collaborative effort, a group of researchers used the numerical simulator of their choice and simulated the MDT test (Anderson et al., 2008). Figure 8 shows the measured pressures with one of the modeling results. This simulation exercise indicated that most of the gas generated as a result of dissociation was accumulated in the wellbore and was not produced into the MDT tool. Furthermore, it indicated that the dissociation zone was small (approximately 5 to 15 cm, Kurihara et al. 2008, Pooladi-Darvish and Hong 2010). An interesting phenomenon observed in the pressure response of the tests that involved hydrate dissociation was appearance of an inflection point. The slope of pressure with time was high initially and declined with time as expected. After sometime however, this slope increased again. As reported by Anderson et al. (2008), it is not clear whether this is a reservoir or wellbore effect. This is discussed under “Theoretical Developments”.

**Mallik 2007 – 2008.** Dallimore et al. (2008a) and Yamamoto and Dallimore (2008) have described the flow tests conducted on the Mallik 2L-38 well in April 2007 and in March 2008. The 2007 operations, which were adversely affected by sand flow leading to pumping problems, led to production of approximately 830 m<sup>3</sup> gas during a 15 hour period. The 2008 test included a 6-day period of continuous gas production at sustained rates of 2000 to 4000 m<sup>3</sup>/day.

We are unaware of any published application of PTA techniques for the analysis of the shut-in data of any of the tests. However, Kurihara et al. (2008a) have simulated the 2007 production test using a hydrate simulator. To match the high gas rates observed in the test, it was postulated that sand production may have led to formation of wormholes and a zone of high permeability. The authors estimated that the hydrate dissociation zone could have extended 7 to 10 m horizontally beyond the wellbore. In a companion paper, Kurihara et al. (2008b) review the modeling efforts towards history matching of the Mallik and Mt. Elbert tests and suggest that the 2007 production test at Mallik, although of a similar total duration as the earlier MDT tests at Mallik and Mt. Elbert, had a significantly larger radius of hydrate dissociation, and was therefore more representative of the reservoir. The authors suggest that the MDT tests, because of their small radius of hydrate dissociation, have been more severely affected by the wellbore conditions.

**Theoretical developments.** Theoretical developments on well testing of GH reservoirs have received some attention over the past few years. In one of such developments, Kurihara et al. (2005) examined the applicability of conventional PTA techniques to interpretation of MDT results in hydrate reservoirs. They simulated flow and shut-in periods similar to those at the Mallik 2002 test, and then applied the conventional PTA techniques for analysis of the synthetically generated pressures. By comparing the estimated parameters with the corresponding values in the simulation model, they examined the usefulness

of the conventional techniques. The authors determined that there is a reasonable agreement between  $k_{eff}$  found from application of the conventional PTA techniques, and the average  $k_{eff}$  over the dissociation zone obtained from the simulation model. More precisely, they reported a good agreement between the  $k_{eff}$  of both flowing phases (water and gas) at an areally-averaged  $S_H$  over the dissociation zone, and that estimated from application of the conventional PTA techniques.

In addition to the radial flow infinite acting behavior that was used for estimation of  $k_{eff}$ , the synthetically generated pressures indicated various boundary effects (in the form of increasing or decreasing pressure derivative curves). The authors found that there may be a relationship between these effects and whether hydrate dissociation occurs over a narrow or a wide region. Moreover, the authors found that the relation between the distances to such boundary effects as estimated using the conventional equation of radius of investigation and the dissociating front as observed in the simulator is not clear. For example, the maximum radius of hydrate dissociation in one of the MDT tests was estimated to be between 0.2 and 0.4 m, only a fraction of the distance to the boundary that was found from the application of tradition equation of radius of investigation. The study showed that there could be a close agreement between the  $k_{eff}$  estimates determined from the two techniques; however the application of conventional PTA techniques to hydrate reservoirs is not straightforward.

Gullapalli et al. (2008) used a numerical simulator for the purpose of generating synthetic well-test data and analyzing those using conventional PTA techniques. One of the objectives was to determine if the intrinsic permeability  $k$  of the formation can be estimated from 15-day build-up tests that have been preceded with flow periods of 3 to 15 days. The authors concluded that for a  $k = 1000$  mD formation, reasonable estimates of  $k_{eff}$  to water and gas could be obtained. The application of conventional PTA techniques led to the estimated values of 0.03 – 0.06 mD for gas and 170 to 350 mD for water, with the larger values corresponding to larger production times and more hydrate dissociation. Moreover, the authors suggested that these estimates of  $k_{eff}$  could not be used to determine  $k$  because the range of fluid saturations corresponded to a range of high uncertainty in the relative permeability functions. To improve the analysis, the authors suggested using numerical simulators or long-term production tests of several months followed by a build-up test.

Recently, Gerami and Pooladi-Darvish (2009) developed a PTA technique for interpretation of the flow (drawdown) data for those hydrate reservoirs that are underlain with a free-gas zone. The authors have shown that the diffusivity equation for flow of gas in the underlying free-gas zone when coupled with the thermodynamic relation of hydrate dissociation and the associated energy equation can be cast in a way similar to that used for conventional gas reservoirs. To do this, a dissociation compressibility is defined that is analogous to the desorption compressibility for coal-bed methane (CBM) reservoirs (Bumb and McKee, 1988). The similarity between the two compressibilities is that both incorporate the thermodynamic relation that controls the transfer of methane (or other components) from the solid to the gaseous phase. The difference is in that the dissociation compressibility for GH reservoirs depends also on thermal properties of the formation. This is not included for CBM reservoirs, because temperature effects associated with release of gas are considered negligible. The diffusivity equation in gas reservoirs remains non-linear, requiring definition of pseudo-pressure and pseudo-time. While the relation between pseudo-pressure and pressure can be easily established, the relation between pseudo-time and time depends on changes of average reservoir pressure with time. To establish this relation, the authors have developed a material (and energy balance) balance equation that allows estimation of average reservoir pressure (and temperature) with time (Gerami and Pooladi-Darvish, 2007b). By combining the material balance equation with the diffusivity equation, the authors have demonstrated that the flowing pressures calculated using a numerical hydrate simulator for a drawdown test (i.e., constant rate production) can be modeled using the analytical solution developed using conventional PTA techniques. Figure 9 shows the comparison between the hydrate simulator results and the analytical solution on a log-log pressure and pressure derivative curve indicating close agreement between the two. Figure 9 demonstrates various flow regimes including the early time flow related to partial penetration, followed by radial flow infinite acting before the pseudo-steady state regime. The authors have also shown how each of these flow periods may be interpreted for estimation of the formation  $k$ , wellbore skin, and the total gas in-place including that in the hydrates (Gerami and Pooladi-Darvish, 2009).

Despite the steady progress in testing and interpretation of the well-test data, a significant number of challenges remain.

**Challenges in testing and interpretation.** In this section some of the theoretical and practical challenges associated with well testing and well-test interpretation in hydrate reservoirs are presented.

**Theoretical challenges.** An ideal well-test interpretation solution should be *comprehensive* enough to incorporate the important mechanisms that govern pressure propagation in a hydrate reservoir. This includes effect of gas generated from hydrate dissociation and the controlling factors such as cooling and associated heat flow. At the same time, the model needs to be *simple* enough to allow estimation of those average properties that control flow and gas generation rate. Ideally, an analytical forward solution is desired that when inverted would lead to an interpretation methodology for estimation of the reservoir parameters. Numerical simulators, although much more comprehensive than analytical solutions, depend on many (often unknown) parameters and are not typically suited for determination of average properties. Instead, the parameters found from application of PTA techniques are often used in numerical simulators for long-term predictions. Development of a model that incorporates the important mechanisms of fluid and heat flow and hydrate dissociation but is simple enough that allows development of analytical solutions has been achieved for the case of hydrate-capped gas reservoir (Gerami and Pooladi-Darvish, 2009). The selection of the simplifying assumptions that allow an analytical solution while capturing the important mechanisms was based on a large number of sensitivity studies to understand the dominant mechanisms (Hong and Pooladi-Darvish, 2005, Pooladi-Darvish and Hong, 2004). We suspect that development of similar solutions for more

prevalent GH accumulations, i.e. those that are within the hydrate stability zone and coexist with formation water, will require development of a similar understanding. A complicating factor is that a number of numerical simulation studies have indicated sharp dissociation fronts associated with significant changes in  $k_{eff}$  as hydrates dissociate at those fronts, along with multi-dimensional flow of heat and the fluids (Moridis et al., 2009, Zatsepina et al., 2009). Shahbazi and Pooladi-Darvish (2010) have shown that depending on whether dissociation occurs over a narrow or wide interval, the solution may have two different solutions; one diffusive and one convective. It is not clear whether such a complex and nonlinear problem can be simplified sufficiently to yield analytical solutions.

Well-test interpretation techniques are generally applied to build-up data. This is because the shut-in period is devoid of rate fluctuations that often occur during a flow test, and therefore the pressure data are of better quality during a shut-in period. In conventional well testing, the solution of the flow period (i.e. drawdown solution) is converted to the shut-in solution using the principle of superposition. Superposition is applicable to linear problems, while the problem of hydrate dissociation is highly nonlinear. Assuming that an analytical solution can be obtained for the drawdown period, it is not clear whether the application of the superposition principle renders a reasonable shut-in solution in GH reservoirs.

A concept of significant importance in PTA is that of the radius of influence, but its applicability to GH reservoirs is unknown. Kurihara et al. (2008b) suggested that the conventional equation of the radius of influence could lead to erroneous indications about the dissociated zone. Thomson and Reynolds (1997) have shown that, for multi-phase flow problems where fluid saturations change with time, the conventional equation of radius of influence is invalid as it overestimates the actual radius in the tests. This is consistent with findings of Kurihara et al. (2008b). A development of new equations estimating the radius of influence for hydrate reservoirs has been attempted recently (Shahbazi and Pooladi-Darvish, 2010)

It is expected that more research will lead to the identification patterns in well testing of hydrate reservoirs that are different from those in conventional reservoirs. An interesting case may be related to the inflection point that was consistently observed in the MDT results obtained at Mt. Elbert. In conventional build-up tests that are dominated by reservoir effects, it is expected that the slope of pressure with time would continuously decrease with time. In fact, a diagnostic methodology has been developed, whereby a non-monotonic change in slope of pressure vs. time is indicative of non-reservoir effects, i.e. wellbore effects (Mattar and Zoral, 1992). Consider a GH reservoir starting with an initial pressure that is above the equilibrium pressure. During the flow period, pressure is reduced to below the equilibrium pressure leading to hydrate dissociation. During the shut-in period, pressure would rise and could increase to above the equilibrium pressure leading to reformation of the hydrate. This could be accompanied by a significant change in compressibility as gas turns to solid, affecting the rate of pressure increase with time. Interestingly (and may be coincidentally), the pressure build-up curves for the Mt. Elbert MDT tests show an increase in rate of pressure increase with time, i.e. an inflection point (Boswell et al., 2008; Anderson et al., 2008). This occurs roughly at the equilibrium pressure. As shown in Figure 8, simulation studies have shown that the same pressure behavior can be duplicated if GH reformation is allowed, and its kinetic rate constant is small (Anderson et al., 2008; Pooladi-Darvish and Hong, 2010). However, it is too early to know whether the pressure inflection observed in the Mt. Elbert MDT tests is because of hydrate reformation or a wellbore effect. In the Mt. Elbert MDT tests, gas accumulation in the wellbore played a large role, and it is possible that the change in rate of pressure increase with time – consistent with what is observed in conventional well testing (Mattar and Zoral, 1992) – may in fact be a wellbore phenomenon.

**Practical Challenges.** As the earlier discussion clearly showed, actual well-test data from GH deposits are scarce. It is expected that the ability to interpret these tests will improve as more well test data of longer durations are acquired. A complicating factor is that hydrate reservoirs occur in remote and inhospitable environments (e.g. arctic or offshore conditions), making data collection a difficult, costly and complex proposition. However, these challenges are not unique to well testing, but to any operations (including production) under such conditions. Another complication could be the possibility of high rate of water production in dissociating GH reservoirs (especially in improperly-designed tests in Class 2 deposits), which could greatly affect the tests and the quality of their results. The few data sets available to-date do not seem to support high rates of water production (Yamamoto and Dallimore, 2008), but the field experience is too limited to exclude the possibility.

### **Geomechanical Challenges and Well Stability Related to Production From Hydrate Deposits**

The geomechanical response of HBS in general, and potential well instability and casing deformation in particular, are serious concerns that need to be addressed and understood before gas production from hydrate deposits can be developed in earnest. Several production methods, including depressurization, thermal stimulation, and inhibitor injection, are being considered for extraction of gas from hydrate-bearing formations. However, deposits that are suitable targets for production often involve poorly consolidated sediments that are usually characterized by limited shear strength. The dissociation of the solid hydrates (a strong cementing agent) during gas production can degrade the structural strength of the HBS, which is further exacerbated by the evolution of an expanding gas zone, progressive transfer of loads from the hydrate to the sediments, and subsidence. The problem is at its highest intensity in the vicinity of the wellbore where the largest changes are concentrated, and is further complicated by production-induced changes in the reservoir pressure and temperature. These can significantly alter the local stress and strain fields, with direct consequence on the wellbore stability, the flow and fluid properties of the system, the potential for co-production of solid particles, and consequently on continuing gas production.

A newly developed numerical simulator has enabled numerical studies on well stability and geomechanical performance during gas production from HBS (Rutqvist and Moridis, 2008). The simulator was developed by linking the TOUGH+HYDRATE simulator (Moridis, 2003; Moridis, 2004; Moridis et al., 2008), which describes the system hydraulic, thermal, and thermodynamic behavior in geological media containing gas hydrates, with the FLAC3D geomechanical simulator (Itasca Consulting Group Inc., 2009). Through its respective components, the simulator provides a state-of-the-art solution to the complex problems of coupled processes in HBS.

The simulator has recently been applied to the scientific and engineering analyses of HBS mechanical stability, including well bore and reservoir instability during depressurization-based production from known oceanic and permafrost related hydrate deposits (Rutqvist and Moridis 2008; Rutqvist and Moridis 2009; Rutqvist et al., 2009). Input data for these studies were based on the GH occurrence with the Oligocene Frio sand in the Alaminos Canyon Block 818 #1 well in of the Gulf of Mexico (Boswell et al., 2009) and from the well-characterized GH occurrences at Mallik (Northwest Territories, Canada; Dallimore and Collett, 2005) and Mount Elbert (Alaska, USA) (Boswell et al., 2010b); The geomechanical properties of HBS for both the oceanic and permafrost related GH deposits were taken from laboratory experiments by Masui et al. (2008) on hydrate-bearing Toyoura sand. A standard Mohr-Coulomb elasto-plastic constitutive mechanical model was used, and the parameters describing the mechanical properties were corrected for pore-filling solid content (hydrate and ice). The results of the simulations for both the oceanic and permafrost related hydrate deposits included cases with production from both vertical and horizontal wells are summarized below. An example of simulation output data from a case of gas production from an oceanic Class 2 setting are shown in Figures 10 through 12.

The modeling results show that geomechanical responses during depressurization-based gas production in both oceanic and permafrost related GH deposits are driven by the reservoir-wide pressure depletion,  $\Delta P$ , which is in turn controlled by the production rate and pressure decline at the wellbore. The depressurization of the reservoir causes vertical compaction and stress changes, which in most cases will increase the shear stresses within the reservoir. The increased shear stress may (if sufficiently high) induce shear failure within the reservoir. The effect of pressure depletion on subsidence and stress is shown in Figure 10 for the case of gas production from an oceanic Class 2 setting. In this case, an initial constant rate production from a vertical well led to a 1<sup>st</sup> cavitation (very rapid pressure drop at the well) caused by secondary hydrate blockages near the well after about 240 days (Figure 10a). This was remediated by temporarily ceasing production and injecting warm water around the well. After production resumed, a 2<sup>nd</sup> cavitation occurred after about 315 days. Then, the production rate (after thermally destroying the GH) had to be further reduced. Figure 10 clearly shows that the stress evolution and vertical displacement (subsidence) are approximately proportional to the reservoir pressure decline at  $r = 10$  m, which is, in turn, similar to the pressure decline at the well bore ( $r = 0.5$  m).

The magnitude of the subsidence is proportional to the magnitude of pressure decline,  $\Delta P$ , and depends on the elastoplastic properties of the HBS. In general, the magnitude of subsidence will be much larger in the case of oceanic HBS because of much larger magnitude of pressure decline,  $\Delta P$ , than in the case of a permafrost-associated hydrate deposit. In the case of depressurization-based production in the Alaminos Canyon 818 Frio sands reported in Rutqvist and Moridis (2009), the pressure declined approximately 30 MPa and resulted in subsidence on the order of several meters. For the example in Figure 10, the subsidence is about 2.5 m. Most of the subsidence in this case is as result of compaction in the hydrate free (and relatively soft) zone of mobile water (Figure 11 and 12). In this zone the volumetric strain, which is essentially the vertical strain is about 13%, whereas the strain in the HBS is limited to about 4%. In the case of the production from permafrost deposits at Mallik and Mount Elbert, the pressure decline was limited to a few MPa, which resulted in a subsidence of only a few cm and a compaction strain of less than 1% (Rutqvist et al., 2009). In the case of production from zones beneath permafrost, the subsidence is also reduced as a result of a relatively stiff permafrost overburden. However, the simulation results indicate that subsidence would occur uniformly over a large lateral distance from the well, and may thus be less of a hazard to any overlying infrastructure.

The induced reservoir stress changes are also proportional to the magnitude of pressure decline,  $\Delta P$ , and depend on the elastoplastic properties of the host sediment. The magnitude of changes in the stress field can be much larger in the case of oceanic hydrate deposits compared to the case of permafrost deposits. Consequently, the likelihood of inducing shear failure might be higher in the case of an oceanic HBS. Rutqvist and Moridis (2009) showed that the likelihood of inducing shear failure in the reservoir depends on the initial stress field and the Poisson's ratio of the host sediment. For example, Rutqvist and Moridis (2009), shows that if the stress field is initially near critical stress for shear failure, even a small pressure decline could be sufficient to trigger shear failure in parts of the dissociated reservoir. Such shear failure may generally lead on enhance subsidence as well as sand production. In the case of the production from the Class 2 deposit shown in Figure 10, the stresses difference between the maximum compressive stress,  $\sigma'_1$ , and the minimum compressive stress,  $\sigma'_3$ , increases with time pressure depletion and reach failure condition near the production well after about 1 year of production.

The depressurization induced stress changes and associated strain will also strongly affect well stability and load on the well casing (Rutqvist et al. 2008). In the case of a vertical production well, the pressure depletion will generally unload the formation uniformly in a plane normal to the axis of the well and therefore the load on the well casing will decrease. In the case of a horizontal production well, on the other hand, vertical compaction of the formation acting against the upper part of the relatively stiff well casing or perforation will likely cause shear failure in the formation in that area. Such shearing of the formation leads to breaking of bonds between particles, which then loosens resulting in production of solids (e.g. sand grains)

and creation of cavities around the wellbore perforation. The current analysis indicates that for both vertical and horizontal wells it will be difficult to avoid shear failure in the formation around perforated production intervals of the wells. Thus, appropriate engineering measures, such as sand screens, needs to be applied to prevent solid production.

Thus, it is clear that in the case of oceanic HBS stress changes and the vertical compaction can be substantial. The potential effect of non-uniform reservoir geomechanical properties and fault that might be reactivated during production has not been assessed in the current analysis. Moreover, for poorly consolidated and highly porous sand, formation failure may also occur in the form of pore-collapse in which the mean effective stress increases so much that inelastic grains slippage and rearrangement occurs. Oceanic HBS may be at the highest effective stress in their geological life, which means that their pre-consolidation pressure (or collapse stress) would likely be exceeded during depressurization-based gas production. Under pore-collapse,  $\phi$  and  $k$  may undergo more substantial irreversible changes. Such processes their affect on the gas production from the HBS will be the subject of future studies.

### **Challenges in Well Design, Operation and Installation in Hydrate Deposits**

Gas hydrates have long been recognized as a significant hazard for drilling and production operations. These hazards can generally be defined as uncontrolled gas releases during drilling, and well integrity issues during production.

For onshore gas hydrates, common practice has been to drill through the GH section with freeze-depressed drilling fluids chilled to below 32° F, followed by casing the well using low heat of hydration cement. There is no practical long-term direct GH production experience. In the offshore environment, operators have generally avoided drilling through identified GH deposits, similar to shallow gas or shallow water hazards. Recent deepwater coring and logging campaigns in the Gulf of Mexico and other locations in India and Japan have used riser-less drilling techniques, which allows maximum cooling of the coring fluid while circulating, and prevents gas being circulated to surface. As above, there is no practical long-term direct GH production experience.

Dedicated GH production wells will have to both drill and produce through HBS. This presents a number of unique design challenges which must be considered for both onshore and offshore GH wells including reservoir subsidence, loss of mechanical strength of the HBS along the wellbore, and development of high external pressures along the wellbore (Rutqvist et al., 2008; Freij-Ayoub et al., 2007)

As shown above, gas hydrate production simulations show potential for reservoir subsidence due to loss of mechanical strength of the relatively low strength reservoir sediments due to removal of the GH pore filling material, as well as significantly reduced reservoir  $P$  that increases the effective net vertical stress acting on the reservoir sediments

Reservoir subsidence is a common problem in many fields, not just in GH deposits. Typically, reservoir compaction greater than approximately 5% appears to be a consistent indicator for potential casing failures. Casing shear is the dominant failure mechanism, typically located in the overburden up to several hundred feet above the reservoir. There is typically little that can be done to prevent casing shear, other than strategic well placement. Field development economics should include a suitable budget for future well replacements if casing shear is expected.

Reservoir subsidence can also result in tensile failures of the casing above the reservoir, and buckling failure within the reservoir. Tensile failures may be prevented through the use of slip joints or length expandable casing joints, placed strategically in the wellbore (common in heavy oil operations). Casing failures due to column buckling in the reservoir interval can be prevented by selecting heavy wall casings and by employing good cementing and solids-control practices.

Gas hydrates will undoubtedly also be present in shales, silts, and non-commercial sand stringers above the target GH reservoirs. High gas production rates from deeper formations can result in dissociation of the hydrates in the near wellbore area. This can result in a reduction of mechanical properties of the sediments supporting the wellbore, and the generation of free gas around the wellbore at pressures up to the fracture gradient.

For onshore wells, the loss of mechanical strength of the sediments supporting the wellbore can be compensated by supporting the well from the top. Typically the wells will be drilled from a gravel pad, offset from the reservoir, and possibly use a refrigerated conductor to prevent permafrost degradation at surface. The development of casing collapse loads due to high-pressure gas can be dealt with by proper casing selection and good cementing practice. Migration of gas along the wellbore can be more problematic (gas flows at surface, formation breakdown and possible close flow, etc.), and must be considered on a field-by-field basis.

Deepwater wells are typically drilled without the riser in place, from the seafloor to approximately two thousand feet below the mudline. This depth may vary well exceed the depth of the GH stability field in many cases. Generally before drilling out the base of the GH stability field or where the potential for free gas exists, the riser will be installed before drilling ahead. This means that GH wells will require nominal 36-inch structural casings plus nominal 20-inch conductor casings (similar to all deepwater wells) to support the loads from the drilling blow out preventers and the riser loads. Initial sediment strengths (with gas hydrates undisturbed) should be sufficient for this. However if the sediment strength is diminished due to GH dissociation or gas flow around the wellbore, this may become problematic, especially later in the life of the field when the subsea tree, blow out preventer, and riser is in place.

### **Challenges in Field Operations of Production from Hydrate Deposits**

The preceding discussion has described issues related to potential commercial production from sand-dominated GH reservoirs. Sand reservoirs are considered the most prospective for initial production from GH due primarily to the high

intrinsic (in the absence of gas hydrate) permeability of the host sediment (Boswell and Collett, 2006). The production characteristics of GH reservoirs will vary greatly depending upon pay zone thickness and lithology, hydrate saturation, pressure and temperature, proximity to free water or free gas layers, and well orientation. The production challenges for gas hydrates will be highly variable from field to field, whether onshore or offshore, and are therefore discussed in general terms only.

For gas production, depressurization can be used alone. Thermal or chemical stimulation techniques may be combined with depressurization if  $S_H$  (either the initial or, more likely, that of the secondary hydrate that may develop during the long-term gas production from hydrates) is so high that flow is restricted. All of these techniques can be used in conjunction with vertical wells, or high angle, horizontal, or multi-lateral wells. Fracture stimulations to increase surface contact area with the wellbore may also be used in conjunction with these well types. Depressurization is thought to be the most technically efficient means of production from natural GH deposits, and is the basis for the economic studies referred to later in this paper.

Most research programs have targeted coarse-grained sand deposits as the most promising reservoirs for the production of GHs. In Class 1 and Class 2 deposits, dissociation can be initiated by producing from the layer of mobile fluids that underlay the hydrate layer and dropping the reservoir pressure below  $P_e$  at the prevailing  $T$ ; the fluids in these two deposit classes are theoretically in contact with a large surface area of gas hydrate, which should increase GH response (more so in the case of the nearly incompressible water in Class 2 deposits; less so in cases of strong water drive which will hinder pressure drop with water production). Because Class 3 deposits have no free water or gas contacts, dissociation can be initiated in the wellbore contact area only.

It is important to emphasize that GH dissociation takes place in the reservoir. The transformation from a solid GH crystal to free gas and free water phases will begin next to the production wellbore, and move away from the well over time as dissociation continues. Therefore, from a producing well perspective, the well design must allow for the production of natural gas with some free water. GH wells will be more complex than most conventional and unconventional gas wells due a number of technical challenges, including:

- Maintaining commercial gas flows with high water production rates – this will require some form of artificial lift (typically gas lift for offshore developments or electric submersible pumps for onshore developments);
- Operating with low temperatures and low pressures in the wellbore – to prevent hydrate formation or freezing in the wellbore and flowlines – this will be especially critical for onshore developments which will be producing from below thick permafrost layers.
- Controlling formation sand production into the wellbore; and
- Ensuring well structural integrity with subsidence in the reservoir, and GH dissociation around the wellbore.

Technologies exist to address all of these issues, but will add to development costs, especially compared to other non-conventional sources of natural gas. GH development also has one distinct challenge compared to other unconventional resources, and that is the high cost of transportation to market.

Water production is not uncommon in gas wells, however water rates are typically less than say 10 bbls/MMscf (barrels of water per million standard cubic feet of gas) for water of condensation and/or free water production. Wells that produce excessive amounts of water are typically worked-over to eliminate water production or shut-in as non-economic. The water production from a GH reservoir could be highly variable, however water-to-gas ratios in excess of 1,000 bbls/MMscf are possible. This water must be removed from the reservoir and wellbore to continue the dissociation process. On this basis, a GH development will require artificial lift such as electric submersible pumps or gas lift, which will also increase capital and operating costs over the life of the field. The water in GH contains no salts or impurities, it is fresh water, although it will certainly mix with non-GH formation waters such that the produced fluids are likely to be brackish. Most gas fields require some compression to maximize reserve recovery, but this typically occurs later in the life of the field after production starts to fall below the plateau rate. For a GH development, the required pressure to cause dissociation will require the use of inlet compression throughout the life of the field including the plateau production time. This will require a larger capital investment for compression at the front end of the project, and will also result in higher operating costs over the life of the project.

The combination of low operating pressures and high water rates will require larger tubing and flowlines for a GH development, in order to minimize friction losses and maximize production. This will therefore require a larger wellbore than would otherwise be required.

Additional water-handling facilities and water disposal will also be required. Larger inhibitor volume (such as glycol) will be required to prevent freezing and hydrate formation in tubing and flowlines. Other items such as sand control, reservoir subsidence, downhole chemical injection, possible requirements for near wellbore thermal stimulation, etc., will also require additional capital and operating costs for GH developments compared to conventional gas developments.

Pressure drawdown in the wellbore is very easy to control by flowing the well against a low pressure at surface. Artificial lift will be required to remove produced water in order maintain low pressure in the wellbore. Pressure reductions in the reservoir can be effective many hundreds or even a thousand or so feet away from the.

Thermal stimulation techniques have been used effectively in heavy oil applications. Steam applied in SAGD (steam assisted gravity drainage) operations or “huff and puff” (alternate steam injection and oil/water production cycles) are used

most commonly (a ref would be nice). Electrical, including induction and resistance heating as well as microwave, has had some limited success. Heavy oil wells are typically quite shallow and relatively low cost. Thermal conductivity in the reservoir is low therefore steam-injection wells must be drilled relatively close to the production wells. Because of the value of the product (oil), heavy oil developments can afford the capital and operating costs associated additional well and thermal operations.

For GH developments, the value of the product produced (gas) is much lower than the value of the product produced in heavy oil operations on a per volume basis. Therefore GH developments cannot be effectively drilled at the close well spacing that is used in heavy oil. In addition, most of the product heated in the reservoir is actually water (1 volume of gas hydrate releases 0.87 volumes of water) which means that much of the heat transferred into the reservoir is wasted. On this basis thermal operations for gas hydrates will probably not be economic. Likewise chemical usage to cause GH dissociation will probably not be economic on the basis of the sheer amount of chemical required on a reservoir scale. However research in both thermal and chemical stimulation methods will continue and elements of both may be incorporated in final well designs.

### **Challenge of Extending Production Beyond Sand Reservoirs**

Currently, the greatest potential for gas hydrate production are those units of sand lithology with high intrinsic (in the absence of gas hydrate) permeability (Boswell and Collett, 2006). As discussed above, this permeability enables the fluid and gas migration necessary for gas hydrate to accumulate to saturations of 60% of pore volume and more. Furthermore, it provides the means for both transmitting destabilizing pressure and temperature pulses from wellbores and provides the pathways by which dissociated methane can be collected by those wellbores. It is currently not well known how large the resource of gas hydrate that exists in sand reservoirs is, but it is clearly sizeable, with significant accumulations now known from both Arctic and the marine environments (Boswell and Collett, in press). Current best estimates are that the in-place resources within sand reservoirs in the Gulf of Mexico alone likely exceed 6,000 tcf of gas (Frye, 2008). If this is correct, given expected recovery efficiencies, a technically recoverable resource exceeding 1,000 tcf is reasonable just within the Gulf of Mexico.

However, this sand-housed resource is just the tip of the hydrate resource pyramid. Large volumes of in-place methane are known to exist as widely disseminated, low-concentration accumulations in locations such as the Blake Ridge (Paull et al., 2000). Furthermore, recent expeditions offshore India (Collett et al., 2006), Malaysia (Hadley et al., 2008), and Korea (Schultheiss et al., 2009; Park, 2008) have revealed thick sections of gas hydrate at elevated concentrations within fine-grained, fractured, sediments. Recent studies of the complex responses of such deposits in typical well log data suggests that ultimate gas hydrate saturations in such accumulations may only typically be 20%-30% of pore volume (Lee and Collett, 2009). Nonetheless, such occurrences may be relatively common, and may occur more widely than the sand-hosted variety. Consequently, the prospects for production from such reservoirs should be investigated. In addition, economic and environmentally sound production of such deposits clearly faces enormous technical challenges, derived not only from the general leanness of the deposits, but by the low-permeability and the low-strength nature of the enclosing sediment (a serious concern with significant geomechanical implications in terms of formation and well stability). Transmission of pressure pulses will be very difficult, and the sediments are likely not competent enough to enable induced fractures to remain open. However, some potential is afforded by the volume change that would be expected to be associated with gas hydrate dissociation. Such internal stresses and strains generated by dissociation could enhance formation permeability locally, providing a means for both the further transmission of pressure reductions as well as the flow of gas to the wellbore (Yun et al., 2010a). Nonetheless, whereas it now appears that gas hydrate production from sand reservoirs is conceivable using largely existing processes; it is clear that much more needs to be known, and perhaps fundamentally new approaches developed, to further the prospects of production from elements lower in the gas hydrates resource pyramid.

### **Challenges in Monitoring Production and Geomechanical Stability in Gas Hydrate Accumulations**

As the gas hydrate community moves forward in designing and testing methods for producing gas from GH accumulations, there is an increasing need to identify suitable techniques for monitoring hydrate accumulations during production. It is hoped that time-lapse geophysical methods will provide valuable information in highlighting the extent and character of hydrate dissociation. Such information can improve understanding of the flow and transport processes occurring during production, and ultimately help manage production and related geohazards (e.g., induced instability at nearby wells, seal integrity loss and associated gas migration).

Many studies have demonstrated the successful application of geophysical methods for locating, delineating and characterizing hydrate accumulations in a variety of geological environments (see the section entitled "Challenges in the Analysis and Interpretation of Geophysical Surveys"). However, the feasibility of remotely monitoring GH accumulations during production is only beginning to be examined.

**Use of geophysical methods for monitoring production versus exploration.** As described previously, the type of geophysical measurement that has been used most successfully for exploration (i.e., reservoir evaluation and resource estimation) is surface seismic. 2D and 3D surface seismic data have been used extensively for mapping the distribution of GH accumulations around the world, both in sub-marine environments and below permafrost. Most often, such surveys are intended to locate hydrate accumulations and delineate their large-scale features, such as the upper and/or lower boundaries,

and to provide rough estimates of the average hydrate saturation. Advanced processing techniques can also allow for depth-varying estimates of hydrate saturation over large areas (e.g., Dai et al., 2008; Lee et al., 2009; Riedel et al., 2009), though their applicability depends on the depth and thickness of the hydrate.

In exploration surveys, little prior information is available, and the primary goal is to determine whether hydrate is present and, if so, how much. In contrast, investigations using geophysical techniques for monitoring production will likely be focused on much smaller regions, namely in the vicinity of production wells. While more prior information will be available for characterization (e.g., detailed logging data), there will also be a demand for increased resolution and measurement repeatability in order to image small variations in properties.

In general, higher resolution information is required for monitoring production than is typically available from surface seismic data, possibly necessitating in some cases the use of VSP (e.g., Milkereit et al., 2005) or cross-borehole measurements (e.g., Watanabe et al., 2005) at the expense of decreased area of investigation.

**Challenges in monitoring production with geophysical methods.** In order to use geophysical methods to monitor production from hydrate accumulations, a number of fundamental challenges must be considered. They can be summarized as follows:

***Suitability of geophysical methods depends on geological setting and expected production behavior.*** The spatial and temporal evolution of physical properties in a hydrate accumulation differ dramatically depending on the type of hydrate accumulation that is targeted and the method that is used to induce dissociation in the formation, leading to conditions that are more or less suitable for a particular geophysical technique.

For example, one study predicted that depressurization-induced production from a sub-marine hydrate accumulation in the Gulf of Mexico results in significant changes in a hydrate-bearing layer (HBL) within several months after the start of production. The property variations extend over 800 meters from the production well in the horizontal direction and include decreasing thickness of the HBL, increasing gas saturation and decreasing hydrate saturation within the HBL, and the formation of thin gas layers above and below the HBL (Moridis and Reagan, 2007). Such complex changes appear to be amenable to detection with time-lapse VSP measurements collected in a well located 50 m from the production well (Kowalsky et al., 2010). Another study examined the same measurement configuration for a different hydrate production scenario, namely, production from a permafrost-associated hydrate accumulation at the PBU-L106 site in North Slope, Alaska (Chiaromonte et al., 2009). In this case, changes in the hydrate accumulation were mostly limited to within 5 m of the production well after 2 years, making the system far less ideal for VSP monitoring (at least for the initially tested configuration) than in the previous case.

Cross-borehole measurements may be more promising in some cases, though the spatial coverage they provide is limited to the inter-borehole region. However, in the cross-borehole seismic surveys that were carried out before and during a short-duration production test at the Mallik test site in the Mackenzie Delta, Northwest Territories, Canada, time-variations in the HBL were apparently too minor to be detected in the time-lapse images obtained through waveform inversion (Watanabe et al., 2005).

Careful examination of the nature of the dissociation front that is expected to develop during production is required to determine optimal measurement types and configurations. Predictive modeling of production behavior and the corresponding geophysical response will help determine what measurements are most suitable.

***Rock physics models depend on geological setting and time-varying hydrate configuration.*** A considerable amount of research has been performed to determine rock physics models (the relationships between sediment properties and geophysical properties) for hydrate-bearing sediment based on theoretical considerations, laboratory experiments, and field data (e.g., Helgerud et al., 1999; Lee, 2002; Winters et al., 2007). It is generally accepted that GH can be distributed within sediment in a variety of ways (e.g., acting as cement between grains, acting as the matrix supporting the grains, or existing mainly in pore space), depending on the geological setting, which dramatically affects seismic and electrical properties of the sediment mixture (see review by Waite et al., 2009). For the purpose of geophysical monitoring at a given site, the rock physics model must be determined in advance using site-specific data.

While well logging and core data should allow for these models to be determined, care must also be taken to analyze how the geophysical properties will change during the course of production (i.e., with the introduction of gas and the lowering of hydrate saturation). The hydrate and gas saturation may change substantially from the ranges of values initially used to develop the models. Furthermore, as the hydrate saturation decreases during production, it may be fitting to switch to a model that accommodates a different hydrate configuration (e.g., from a model in which the hydrate affects the properties of the rock matrix at higher saturations to a model in which the hydrate primarily affects the fluid properties at lower saturations).

The rock physics models must be implemented as a function of the relevant properties as they are expected to change during production in order to accurately interpret geophysical field data.

***Simultaneously changing physical properties can lead to non-unique interpretations of time-lapse geophysical data.*** In addition to being related to hydrate saturation, geophysical properties are a function of the water and gas saturation, and pore fluid pressure. Therefore, it is difficult to uniquely attribute the change in a geophysical measurement to any particular property, like the hydrate saturation.

For example, when production of a hydrate accumulation is induced by depressurization, the P-wave velocity can vary due to changes in both the effective pressure and in phase saturations. As fluid is removed from the system and the fluid



pressure decreases, the effective pressure (defined as the difference between the lithostatic and pore fluid pressure) increases, corresponding to increased values of the frame bulk moduli of the sediment (Dvorkin et al., 1999). At the same time, the increases in velocity are offset by the decreases that result from the decreasing hydrate saturation and increased gas saturation (Kowalsky et al., 2010).

It is clear that changes in the geophysical signal cannot be directly related to changes in hydrate saturation without considering how the other properties are changing. A given set of geophysical data should be interpreted in consideration of the physical processes occurring during production, and a coupled modeling framework is helpful for this purpose.

**Coupled modeling of production and geophysical response.** Given the susceptibility of particular types of hydrate deposits to geomechanical changes, and the possibility for severe stability and well stability consequences, the ability to monitor geomechanical changes by geophysical means is particularly appealing. A modeling approach that allows for the coupled simulation of hydrate production and corresponding geophysical measurements is a useful tool for constraining the interpretation of geophysical data collected during a production test, and for designing geophysical surveys with maximum sensitivity to the process of interest.

This approach was used to conduct a feasibility study for using VSP measurements to monitoring production from a submarine hydrate accumulation in the Gulf of Mexico (Kowalsky et al., 2009); the study is briefly described here to demonstrate the usefulness of the approach. The synthetic VSP measurements, simulated together with production using the numerical grids shown in Figure 13, appear to be sensitive to changes occurring in the hydrate accumulation during production. For the case of an incoming P-wave source, the most reliable indicators of changing conditions in the HBL appear to be converted S-waves transmitted through the HBL and recorded below it (Figure 14), and reflected P-waves and converted S-waves recorded above the HBL. The sensitivity of the response to the chosen rock physics models is apparent (a-d), emphasizing the importance of accurately determining the rock physics model with site-specific data.

Future improvements to this approach should include coupling to a geomechanical code (e.g., Rutqvist and Moridis, 2009). In addition, additional types of measurements that provide complementary but lower resolution information, such as electrical and electromagnetic data, should be evaluated.

### Challenges in Laboratory Investigations in Support of Gas Production Analysis

Laboratory investigations are performed both in field laboratories and conventional laboratories on natural samples and laboratory-synthesized samples to understand the thermodynamic properties (e.g. the equilibrium curve, effect of pore size, effect of inhibitor, hydrate structure), gas composition, mechanical, electrical, thermal, and hydrologic properties of HBS. Understanding these properties is important in predicting (1) the amount of gas that can be produced from a reservoir, (2) providing “ground-truth” for geophysical and well log measurements (Collett et al., 2008), (3) understanding the mechanical strength of the reservoir medium, and (4) understanding how gas will be produced.

**Natural Samples.** The results of examining and testing natural HBS cores in the laboratory environment are dependent on the quality of the collected core, and the quality of the subsampling and analysis. Gas hydrate is stabilized by elevated guest constituent (e.g. methane) pressure at lower temperatures, and increasing pressure is needed for higher temperatures and for higher solute or inhibitor concentrations in pore water. Drilling often requires dense muds having high ionic strength, which can alter pore water chemistry and cause hydrate dissociation (e.g., Torres, 2009). Oil-based muds can be used to minimize pore water chemistry changes. At the Mount Elbert Stratigraphic Test Well in Alaska in 2007, temperature-controlled, fit-for-purpose oil-based mud was used to minimize pore water chemistry changes and to cool the core (Hunter et al., 2010). Pressure coring has been used on a number of oceanic expeditions (Schultheiss et al., 2009) stabilizing the core pressure at the pressure the core was collected. Sampling and test equipment, such as the instrumented pressure testing chamber shown in Figure 7a (Yun et al., 2006; Yun et al., 2010b) has been built and instrumented to make measurements on the obtained pressure core without removing the pore pressure. This device can be modified to allow for other measurements to be made, however not all required measurements can be made using this apparatus. Field based x-ray imaging and CT-scanning, useful for understanding the core conditions and to identify representative locations for sampling and analysis, has been performed for pressurized and nonpressurized core (Collett et al., 2008b;c; Holland et al., 2008; Freifeld and Kneafsey, 2004).

Preserving core for later examination in laboratories must be performed carefully. Many measurements require briefly removing a sample from hydrate-stable conditions to transfer it into a testing apparatus, resulting in sample changes. Waite et al. (2008) examined effects of briefly depressurizing samples prior to making measurements and concluded that hydrate near the surface tended to dissociate, and the water of dissociation was imbibed into the sample center. When the sample was repressurized, additional hydrate formed in the center of the sample, and the region near the surface was partially depleted of hydrate. This hydrate redistribution was also reported by Kneafsey et al. (2009) for Mount Elbert samples preserved for a time by repressurization with methane gas. This hydrate redistribution affects sample mechanical, flow, thermal, and electrical properties. Freezing samples in liquid nitrogen will preserve hydrate and may be the best technique for maintaining the hydrate chemistry, however, this technique can cause large thermal stresses in the sample inducing fracturing throughout and impacting non-chemistry measurements made on the sample (Kneafsey et al., 2009).

In selecting a re-pressurized core or one preserved in liquid nitrogen for testing, it is helpful to image the core by x-ray computed tomography (CT) to look for representative regions for sampling, and to avoid regions damaged by sampling and

preservation. Returning a preserved core to natural conditions must also be carefully performed prior to testing. A sample preserved in liquid nitrogen may be carefully machined while kept very cold without losing the hydrate. Placing cold samples in test vessels can also be performed carefully, particularly if the equipment contacting the sample is properly chilled such that the entire system can be warmed imposing low thermal gradients. Materials in contact with the sample must perform at near-liquid nitrogen boiling temperature and under the test conditions.

### Laboratory-synthesized samples

**Hydrate formation.** Many conventional laboratory investigations have been performed on laboratory-synthesized samples. These allow the flexibility of creating samples that have desired characteristics. Few laboratory-synthesized samples have been examined for uniformity, and this characteristic is often (perhaps hastily) assumed. Examination of HBS samples using CT or micro-CT has been performed in some studies to document sample uniformity (Gupta et al., 2006; Kerkar et al., 2009; Kneafsey et al., 2007; Seol and Kneafsey, 2009; Tomutsa et al., 2002; Waite et al., 2008). An example of a nonuniform hydrate distribution is shown in Figure 15. Several methods are in use for making synthetic HBS, and each has its advantages and disadvantages.

**Hydrate from ice.** In this method, powdered ice is slowly melted in the presence of methane at the appropriate pressure and temperature (Stern et al., 1996). As the ice melts, methane hydrate is formed. Sequential freezing and melting events can result in very high conversions to hydrate (L.A. Stern, personal communication). The hydrate can then be chilled in liquid nitrogen, powdered, mixed with a selected chilled mineral medium, and compacted into a hydrate-bearing medium. Nanoscale examination using scanning electron microscopy of HBS formed this way compares favorably to natural HBS from the Mallik site (Figure 16) (Stern et al., 2004). HBS formed this way will typically fill pores as well as be part of the frame of the medium.

**Hydrate from partially water saturated media – Excess Gas.** In this method, a prescribed amount of water is uniformly added to a mineral medium, compacted into a sample vessel, and the hydrate stability conditions are exceeded (Handa and Stupin, 1992; Kneafsey et al., 2007; Waite et al., 2004). Hydrate formed using this technique typically cements mineral grains together forming a stiff sample (Waite et al., 2004). Examples of hydrate saturation distributions of two samples formed using this technique are shown in Figure 15.

**Hydrate from partially water saturated media – Excess Water.** Using a somewhat different approach, Priest et al. (2009) formed methane hydrate in samples by placing the quantity of gas needed to form a specific amount of hydrate in a porous sample, pressurizing the sample with water, and then chilling the sample to bring it into the hydrate stability field. Their work suggests that hydrate interaction with the sediment is strongly dependent on hydrate morphology, with results indicating that hydrate formed this way is frame supporting.

**Hydrate from dissolved methane.** In this method, water containing dissolved methane is flowed through a chilled porous medium where hydrate is formed. Although there have been some successes using this technique, it is difficult to control and time consuming (Spangenberg et al., 2005). Production of a single sample may take several tens of days, and sample uniformity has not been investigated.

**Analog hydrate from dissolved-phase liquid.** In this method, a water-soluble guest is used instead of methane (e.g. tetrahydrofuran - THF). Water and THF are mixed in the proper ratios and then chilled to below the hydrate-forming temperature. THF hydrate has been used as an analog for methane hydrate in many studies because it is rapidly formed at atmospheric pressure, and devices for making measurements on resulting samples are readily available (Lee et al., 2007; Yun et al., 2007). Computed microtomography of THF hydrate-bearing samples has recently been performed showing hydrate formation in the pore space of a glass bead porous medium (Kerkar et al., 2009).

**Micromodel studies of gas hydrates.** Several studies have been performed allowing direct microscopic examination of THF, carbon dioxide, and methane hydrate formation, aging, and dissociation in transparent micromodels (Katsuki et al., 2006, 2007, 2008; Tohidi et al., 2001, 2002;). These studies show formation of hydrate with a gas phase present, and without a gas phase present (for CO<sub>2</sub> and THF hydrate), formation of dendritic hydrate crystals that age over time into particulate hydrate crystals, and faceted hydrate crystals formed at low subcooling. The presence of a water film between the hydrate and the micromodel cell walls has been observed in some tests, but not in others leading to the conclusion that hydrate may cement grains together when formed with a low degree of subcooling. In spite of differences between natural porous media and the micromodel environments, these studies are very important in providing direct observation of hydrate behavior in these analog porous media.

**Thermodynamic Properties.** Sloan and Koh (2008) summarized (a) laboratory measurements and (b) models that provide estimates of the heat of hydrate formation and dissociation, in addition to equilibrium conditions ( $P$ ,  $T$ , and inhibitor concentrations) of various states (i.e., phase co-existence scenarios) for many hydrate systems. The kinetics of hydrate formation were studied by Bishnoi and coworkers (Clarke and Bishnoi, 2001; Kim et al., 1987), who measured the activation energy and intrinsic rate constant of methane hydrate decomposition. Modeling by Moridis et al. (2005) and Kowalsky and Moridis (2007) has shown that dissociation kinetics will play little to no role in gas production from hydrate at the reservoir-scale, however it may play a role in understanding sampling impacts and in short-term laboratory studies.

A number of studies have been performed examining the effect of pore size on hydrate equilibrium. Klapproth et al. (2006) formed methane hydrate in quartz sand, quartz sand with kaolinite, and quartz sand with montmorillonite clay

particles. The water was added by making 10 $\mu$ m frost in a chamber, and from 10% to 17% frost by mass was added to each medium. Hydrate was made at 3°C from the melting ice, and SEM was used to examine the pore structure. Hydrate formed most readily in the samples containing the montmorillonite, which apparently sorbed to the air-water interface. The presence of kaolinite caused more gas to be consumed upon hydrate formation, however.

Uchida et al. (2004) investigated the differences in equilibrium conditions between bulk methane hydrate and methane hydrate in silica sand, Berea sandstone, two sizes of glass beads, two kaolinites, and two bentonites. Hydrate formation was impeded where pore spaces were narrow, yielding stability temperature differences between bulk hydrate and hydrate with bentonite of as much as 8°C. The effects for kaolinite were much smaller (~1.5°C) and were comparable to those for 20  $\mu$ m glass beads. Bentonite, composed primarily of montmorillonite, swells when wetted by water, allowing hydrate formation between mineral layers. Bentonite was shown to have the ability to enhance hydrate formation under certain conditions.

Uchida et al. (2002) measured the change in dissociation temperature for porous glass and silica gel having small pores (<6 to 100 nm). The largest shift for methane hydrate was -12.3°C for 4 nm pores to -0.5°C for 100 nm pores. Handa and Stupin (1992) measured equilibrium temperature and pressure of methane hydrate in 70A silica gel pores. With this size pore, the equilibrium methane pressure is about 1.72 MPa above that of bulk methane hydrate. To help explain the difference between the observed and predicted BSR depths at locations on the Cascadia Margin, Lu and Matsumoto (2002) formed and dissociated methane hydrate in nanofossil-rich marine sediments having pore sizes ranging from 40 to 200 nm (average 170 nm) and particle sizes ranging from 1 to 30 (average 10) and 40 to 250 (average 70) microns. Forming hydrate in this porous medium required a lower temperature of 0.4°C and 1.5°C for seawater and pure water respectively than for bulk hydrate.

**Thermal Properties.** Laboratory measurements of thermal properties of methane HBS have been made by a number of researchers (Gupta et al., 2006; Handa, 1986; Huang and Fan, 2005; Moridis et al., 2005; Rosenbaum et al., 2007; Turner et al., 2005; Waite et al., 2002; Waite et al., 2007) as reviewed by Waite et al., (2009). Two thermal properties are important – thermal conductivity and specific heat. Thermal diffusivity can be computed from these properties and the density of the medium. The thermal conductivity of methane hydrate differs from that of water by less than 10%, thus coarse estimates of a system containing water and hydrate in the pore space may be made by considering the medium to be water saturated (Ruppel, 2000). Consideration of a gas phase, if present, complicates the thermal conductivity because its conductivity is much lower than the other components. Simple mixing models provide reasonable bounds for values of thermal conductivity (Waite et al., 2009). The specific heat of a medium can also be computed using a mixing model and the specific heats of the components present. Because the specific heat of water is about twice that of methane hydrate, the medium specific heat can change dramatically upon hydrate formation or dissociation.

**Flow Properties.** Flow properties of HBS have been investigated because of their importance in understanding the nature and formation of hydrate-bearing reservoirs and gas production. Because hydrate dissociation produces water and gas, understanding how the presence of hydrate in the pore space influences gas and water flow is critical in predicting gas recovery. The two main properties needed are the formation  $k$ , the relative permeabilities  $k_{rA}$  and  $k_{rG}$  of the aqueous and gas phases, respectively, and the relationship of the capillary pressure  $P_{cap}$  to the saturations of the fluid phases. In cases where the hydrate is part of the skeletal frame of the medium, the formation  $k$  can be estimated but not measured, and hydrate dissociation will alter the structure of the medium. Moridis et al. (2007) devised two conceptual methods of handling this issue. Capillary pressure – saturation relationships describe the medium water saturation at given pressure differences between the water and gas phases. The capillary pressure at a given saturation depends on path (imbibition or drainage), thus is non-unique and exhibits hysteresis.  $P_{cap}$ ,  $k_{rA}$  and  $k_{rG}$  in a HBS are dependent on the saturation of all the phases present, and whereas a curve describes either of these relations for a system with two fluid phases, the presence of hydrate requires a three-dimensional surface to describe these relations. To date, few studies have been performed covering the range of values or media expected in hydrate-bearing reservoirs.

Kleinberg et al. (2003) compared  $k_{rA}$  estimates of deep-sea sediments from NMR data to a number of models concluding that the Kenyon equation can be used to predict the  $k_{rA}$ , however stating that relative permeability measurements are needed to verify this. Jaiswal (2004) measured the  $k_{rG}$  of laboratory-formed hydrates in two sands, and pointed out many difficulties in making these measurements including fines migration and hydrate dissociation from establishing a pressure gradient. Minagawa et al. (2005) measured  $k_{rA}$  of four sands at multiple hydrate saturations and fit their data with an exponential relation. The value of the exponent ranged from 2.5 to 9.8. Kneafsey et al. (2008) presented the results of a series of relative permeability measurements made on laboratory-formed hydrate in two sands and a sand-silt mixture. In their work,  $k_{rG}$  measurements of the same sample under moist, frozen, hydrate bearing, and dry are compared, and x-ray CT scans were performed to examine the uniformity of the samples under each of these conditions. They compared their data to the models used by Kleinberg et al. (2003) and concluded that, for the purpose of relative permeability, the hydrate behaved in a pore-filling manner in spite of it being formed from excess gas. Recently, Kumar et al. (2010) presented  $k_{rG}$  measurements on glass bead packs containing CO<sub>2</sub> hydrate up to 49% saturation. These authors concluded that at hydrate saturations below 35%, hydrate formed on the grain surfaces, but above a hydrate saturation of 35%, hydrate was pore filling.

One study presenting measurements of  $P_{cap}$  vs. saturation of methane hydrate-bearing sands has been published (Ghezzehei and Kneafsey, 2010), and additional measurements are being made. These measurements are extremely difficult because the system temperature, pressure, and volume must all be held to precisely maintain equilibrium conditions in the

sample over long times while fluid is withdrawn from a sample, hydraulic equilibrium states are attained, and differential pressure is measured.

**Mechanical Properties.** Waite et al. (2009) provide a summary of laboratory measurements of the mechanical properties of HBS. Only a few studies are described here. A systematic study of the mechanical properties of THF-hydrate-bearing sediments has been performed for sand, crushed silt, precipitated silt, and clay specimens containing 0, 50%, or 100% THF hydrate saturation (Yun et al., 2007). These authors concluded that the type of sediment, applied confining stress, and hydrate saturation govern the load-deformation response of HBS. Before peak strength is attained, a clear yield point is identified, associated with the hydrate and particle de-bonding. In addition, hydrate exhibits a greater impact on shear strength at lower confining stresses. High hydrate saturation enhances the strength, the stiffness, and possibly the dilative tendency of sediments by increasing interparticle coordination, by cementing particles together, and by filling the pore space. No corresponding systematic study for methane HBS has been published, although such studies have been initiated. The mechanical strength of a number of laboratory-formed and natural methane hydrate-bearing samples has also been measured (Masui et al., 2005; Masui et al., 2008). Studies of mechanical properties of HBS have been hampered by complex equipment needs, and the difficulties of working with methane hydrate. A novel device for the measurement of the triaxial strength of methane HBS has been constructed (Figure 17) and testing will be implemented soon. Data are needed particularly for hydrate saturations below 50% and for fine-grain media because much of the hydrate in oceanic deposits is present in low saturations providing risk to oil and gas operations. In these tests, the morphology of the hydrate must be known and controlled.

**Electromagnetic Properties.** Knowledge of medium electrical properties is useful in hydrate prospecting and monitoring HBS undergoing changes such as from gas production. Either electrical conductivity or permittivity can be used to distinguish between water and non-water pore filling materials such as hydrate and gas. Electrical conductivity is dominated by the conductivity of the pore fluid, however surface conduction must be considered for high surface area sediments (Klein and Santamarina, 2003). Under conditions where hydrate forms or dissociates, the pore fluid conductivity will change due to freshening (hydrate dissociation) or ion exclusion (hydrate formation). Because the effect of ionic concentration is much weaker for the permittivity, this may be the more reliable indicator in many circumstances. In a systematic examination of the effects of THF hydrate on a sand, two silts, and a clay, laboratory measurements of electrical conductivity and permittivity have been measured (Lee, 2007). These properties have also been measured for sediments from the Gulf of Mexico with and without THF hydrate (Lee et al., 2008). Electrical resistivity (inverse of conductivity) has been measured on methane hydrate samples in a few cases (Spangenberg and Kulenkampff, 2005; 2006). No comprehensive study has been performed for methane HBS.

**Geophysical properties - wave velocities and attenuation.** Compressional (P-) and shear (S-) wave speeds have been measured in a variety of medium/hydrate combinations. Berge et al. (1999) measured P- and S-wave velocities of Refrigerant 11 hydrate in two sands at 2C. No S-waves were detected below hydrate saturations of 35%. P-wave velocities increased with hydrate saturation and with time. Yun et al. (2005) measured p- and s-wave velocities for THF hydrate-bearing sand at a range of hydrate saturations, concluding that at the pore scale, hydrate did not form purely as either cementing or pore filling, but was presumed to nucleate at the grain boundaries and grow outward into the pore space. The authors further concluded that the Gassmann equation can be used to predict the velocity of the P-wave from the S-wave but not vice versa, and that because the P- and S-wave velocities exhibit only small changes from hydrate saturations from 0 to 40%, these wave velocities alone will be ineffective at locating natural HBS at lower saturations. Waite et al. (2004) measured the P- and S-wave velocities for an Ottawa sand at three hydrate saturations. The hydrate was formed using the excess gas method, which was concluded to cement the grains together resulting in very stiff samples. Tests varying hydrate saturation for pore filling and cementing hydrate have been performed using a fine sand medium (Priest et al. 2009). No systematic tests examining P- and S-wave velocities for a variety of porous media types at a range of methane hydrate saturations (and morphology) have been published, however such tests have are now in progress.

**Laboratory Investigation Challenges.** Laboratory studies on natural HBS provide results that are dependent on the coring method and all the sample changes that occur prior to the measurement. In spite of these drawbacks, sampling and analysis of natural HBS provides general information on HBS reservoirs and critical site-dependant information. Laboratory studies of laboratory-synthesized HBS suffer from nonuniform samples, samples that are not perfectly representative of the natural environment, and specialized equipment needs to maintain and test the samples. Hydrate laboratory researchers are striving to meet these challenges, but further development is needed.

Several types of measurements have been made on HBS over a wide range of media and saturations, particularly with THF hydrate. Studies that can convincingly validate (without entirely repeating) the THF hydrate studies using methane hydrate are needed. Additional studies are needed to quantify fluid flow parameters over the broad range of conditions where hydrate occurs. Studies in methane HBS strength are needed to compare to THF HBS studies, and additional studies are required particularly for low hydrate saturations, as it is thought that much of the HBS has these saturations. Better understanding of the effects of fines migration and sand production as a result of hydrate dissociation is needed. These and

future hydrate studies must use well-characterized specimen that possess the fundamental characteristics of natural in-situ HBS including porous medium type, mineralogy, hydrate habit, uniformity, chemistry, and confinement.

### **Challenges in Fundamental Knowledge of Hydrate Behavior**

Such challenges address the basic conceptual framework upon which theoretical and laboratory studies on the thermodynamics and flow properties of the complex GH systems are based. These include:

**Development of universal standards for hydrate sample creation.** This is an important challenge for fundamental physico-chemical hydrate research, and its first involves the establishment of a protocol to fabricate artificial hydrate samples in sediment, which can be replicated from both inter- and intra-laboratory. The second part of this challenge is to ensure that the sample is a reasonable replicate of nature. As various natural GH form in different ways, it is clear however that one approach will not produce samples relevant to all regions. For study of GH-bearing clays formations, the method of Spangenberg et al. (2008) appears to be dominant; however, months of sample preparation time are required, and there is an urgent need for more time-effective techniques.

**Thermodynamic knowledge gaps and time-dependence issues.** Gibbs energy minimization methods are currently the most effective tools in determining the behavior of complex hydrates (a subject that needs to be tackled, as such hydrates are likely in GH systems), and form the basis of the statistical thermodynamics approach in the description of the properties and behavior of such systems. Because of serious experimental difficulties, the predictions of these methods currently cannot be verified under the following six conditions: (1) high  $P$  ( $> 300$  bar) systems, (2) mixed inhibitors, (3) hydrate phase fractions, (4) high concentrations of acid gases, (5) black oil systems, and (6) two phase (e.g.,  $\text{CH}_4$ -saturated water+hydrate). In addition to the six major measurement needs, time-dependent measurements are required, to establish kinetic phenomena, which are currently confounded by the addition of heat and mass transfer.

**Multiphase Flow.** Another fundamental knowledge challenge is to establish a verified transient model of multiphase flow, which is experimentally validated. Currently two-phase flow systems are fairly well established. However, a rigorous three or four phase transient model with experimental verification in flow loops is beyond the current state-of-the-art. Such a model will generally require substantial resources in both time and funds. However, the accurate modeling and experimental validation of such phenomena in systems with co-existent of three or four of the gas, oil, water, ice and hydrate phases will be vital to hydrate control in both energy production and flow assurance.

**Hysteretic P-T behavior.** While the  $\text{CH}_4$  system that is used almost exclusively in gas production study is thought to be well understood and described, an important issue that has yet to be investigated (and the implications of which can be significant) is the hysteresis between the  $P$ - $T$  relationships in a warming and cooling hydrate system. All predictions reported in the literature have relied exclusively on the warming  $P$ - $T$  relationships, while the cooling  $P$ - $T$  relationships have not been quantified. The cooling  $P$ - $T$  curve has a very different behavior (attributed to metastability) that is characterized by a long period of very slight pressure drop during continuous cooling, followed by a precipitous drop in  $P$  beyond a certain point. Because cooling and secondary hydrate formation are quite common in the course of hydrate production (Moridis and Reagan, 2007a;b), such  $P$ - $T$  behavior can have a significant effect on production.

**Fast P-T-X parametric relationships in composite hydrates.** As indicated in an earlier section, even small amounts of a second hydrate-forming gas in addition to  $\text{CH}_4$  can drastically alter the properties and behavior of hydrates. An example of such an occurrence has recently been reported from offshore Malaysia (Hadley et al., 2008). While statistical thermodynamics approaches (Sloan and Koh, 2008) allow good descriptions of the composite system, these are cumbersome, slow and unsuitable for use in numerical simulators. Thus, there is a significant need for fast parametric relationships describing the composite hydrate behavior over the  $P$ - $T$ - $X$  spectrum.

### **Challenges in the Economics of Commercial Gas Production From Hydrates**

**Current status of commercial production efforts; Likelihood of commercial production and the corresponding time frame.** The unconventional oil and gas hydrocarbons currently being developed in North America have one distinct advantage compared to gas hydrates – that being location. Development of shale oil and gas, tar sands, coal bed methane etc. can proceed when the required technology and capital/operating costs are attractive with current market prices.

Unconventional gas projects can generally proceed quite quickly because capital and operating costs are relatively low. Some of the major unconventional gas plays are also close to market, which results in significantly reduced transportation tariffs compared to frontier or offshore gas. This makes it easier for unconventional gas such as tight gas, shale gas, or coal bed methane gas to compete in the North American gas market, even at the low prevailing prices of the current market.

Gas hydrates are located onshore under permafrost in the US and Canadian Arctic regions, and in the deepwater margins around the North American continent – there are currently no unconventional developments, oil or gas, in these frontier areas. These areas also contain significant amounts of developed and undeveloped conventional gas resources, much of which is stranded without a way to get to market.

On this basis, GHs will not compete directly with other unconventional gas resources, but rather will have to compete with frontier conventional gas developments. This puts GHs at a distinct disadvantage compared to other unconventional gas resources for access to the larger North American gas market. While a local market use of gas from gas hydrates may be feasible at some point (say fuel for a North Slope industrial requirement or for a town or village), this situation will largely defer the timing of GH developments until sometime in the future. This is not necessarily the case, however, in certain regions outside North America, where large resources of conventional oil and gas may not be available.

**Economics of production from onshore gas hydrate deposits.** Onshore gas hydrates in North America are located on the North Slope of Alaska and on the Mackenzie Delta in Canada. These resources, along with significant volumes of already discovered conventional gas, are stranded without a pipeline to market. In order to compete for pipeline capacity, the economics of onshore GH developments must be attractive at prevailing gas prices. This may have an impact on the timing of major onshore GH development, however, unique circumstances may allow production for local community or industrial use. For example, an oil lease on the North Slope in short supply of gas for heating and power generation could make use of GH production – the produced gas could be used for fuel, and the produced water could be used for waterflood operations to improve oil recovery. (this was said above, wasn't it?)

The preliminary economics of two different hypothetical onshore GH developments are summarized in this paper:

The first case was based on a Class 1 reservoir. The GH layer in this case had an initial gas in place volume of 1.07 TCF (trillion cubic feet). The free gas layer added an initial gas in place volume of 0.23 TCF, for a total gas volume of 1.30 TCF. The second case was based on Class 2 deposit. As above, the GH layer in this case had an initial gas in place volume of 1.07 TCF (with no free gas component).

In both cases, gas and water production rates were predicted using the commercial reservoir simulator CMG-STARs (CMG, 2005) using highly simplified reservoir depictions. Recent simulations utilizing more detailed inputs that capture natural reservoir heterogeneity have been shown to have markedly different, and more promising, potential production profiles (Anderson et al., 2010; Reagan et al., 2010). As a result, we consider the following discussion to represent a very conservative evaluation of potential gas hydrate economics.

The field development plan consisted of 5 production wells and 2 water disposal wells. Production was initiated via depressurization in both cases. The capital and operating costs for the various field development plans considered in this evaluation were generated using IHS Energy's Que\$tor™ planning software and costing database, plus information from a variety of sources. Additional information on reservoir properties, simulation results, capital and operating costs, and detailed economic discussions are presented in Hancock et al. (2005) and Walsh et al. (2010). Key results from these investigations are summarized in the following discussion. Note that all prices in this section refer to 2009 United States dollars.

Figure 18 presents the predicted gas production rates for the two cases. The first case starts out at a plateau or peak rate of 125 MMscf/d (million standard cubic feet per day), and declines thereafter. Note that conventional gas field developments are normally designed around a plateau or peak production rate lasting say two to five years. This is typically the most economic way to develop and produce a gas field considering capital costs and operating life. The high initial production rate is largely due to the free gas below the hydrate layer. After approximately five years, the total field production rate declines as the free gas is exhausted, and the gas production is due largely to GH dissociation.

The second case starts out at a low gas production rate, and builds slowly to a peak rate at approximately year five and declines slowly thereafter. In this type of reservoir setting, the free water must be produced to initiate GH dissociation, which itself produces significant water volumes. These water volumes must be produced prior to the start of significant gas production, which results in a slow build-up to peak gas production. Typical project economic evaluations are based on risked net present value economics. In this procedure, annual capital and operating costs, along with revenues from gas production, are discounted annually from a starting point. Annual discount rates (or internally rates of return) typically range from 10% to 20% to account for cost of capital and risk. Compared to events that occur early in the life of the project, activities in future years are more heavily discounted and thus have less of an impact on the overall project economics.

A gas-hydrate-only development will characteristically have peak gas production rates occur later in the life of the field, as well as a lower peak production rate and a longer field operating life, compared to a typical conventional gas field. Thus gas-hydrate-only developments will be somewhat penalized for the expected production characteristics when using net present value economics.

Figure 19 illustrates the sensitivity of internal rate of return to gas price for the two cases considered. This evaluation includes revenues, capital and operating costs, typical frontier royalties, but with no incentives or taxes. In addition, a pipeline tariff to the southern US markets of \$2.50/mscf (thousand standard cubic feet) has been assumed.

The first case is reasonably robust as the gas price increases over \$ US 6.00/mscf. This is due primarily to the production of free gas early in the project. The rate of return for the second case is somewhat insensitive to increasing gas price, as the discounting on the delayed peak gas production reduces the impact of increasing price. To achieve a rate of return of 15%, the first case would require a gas price of approximately \$ 6.50/mscf, and the second case would require a gas price of approximately \$12.00/mscf.

Complexities and geologic heterogeneities encountered in any natural settings may either reduce or improve the well performance, which could significantly change project economics. However these preliminary analyses do indicate that the gas price required for a reasonable rate of return for an onshore GH development is only slightly beyond the peak historical

gas prices that have been observed in North America. It is also obvious from these analyses that comparable conventional gas resources will always be more attractive in net present value terms than gas hydrates.

**Economics of production from offshore gas hydrate deposits.** Gas hydrates have also been discovered in the deepwater areas of the Gulf of Mexico and along most of the deep coastal margins throughout the world. Deepwater drilling technology and experience continues to evolve, and the worldwide deepwater fleet continues to expand. However the deepwater environment is still a very high cost and very high-risk area of operation. Offshore GH developments must have strong economic drivers in order to compete with other deepwater exploration and development opportunities.

By all estimates, the majority of GHs considered for production are located in sandstone reservoirs in deepwater environments. In order to understand the economics of deepwater GHs, stand-alone field development plan were prepared for a GH accumulation not in contact with gas or water-bearing reservoirs. The GH production rates were based on a study conducted in Moridis and Reagan (2007) for a deepwater Gulf of Mexico reservoir condition, which used the TOUGH+HYDRATE numerical simulation model. Capital and operating costs were again developed using IHS Energy's Que\$tor™ development planning tool and costing database program. For comparison purposes, a similar sized deepwater conventional gas field was developed using the same tools in order to determine comparative economics.

The field development plans for both fields assumed a subsea development in 5000 ft of water. A new purpose built floating production facility plus a 75-mile pipeline are added to standard costs such as compression, dehydration, and separation. Extra costs associated with hydrate gas production, such as artificial lift, reduced platform pressure, and flow assurance are also considered, in addition to sand control. It was assumed that there would be sufficient wells in place to maintain a plateau production rate of 500 MMscf/day, and recover 2.0 TCF of produced gas over a 20-year life. Additional wells were added for both development types to account for structural and drainage issues typically encountered in large areal discoveries.

Figure 20 illustrates the typical gas production profile for the GH wells studies in Hancock (2008). This result follows the previous discussion regarding delayed onset of peak production followed by a decline as the GH is exhausted. Also as discussed, significant production of water is required to continue the gas dissociation process. Figure 21 illustrates the predicted water to gas ratio for the simulated well. For the first several years, the predicted water volumes are significantly higher than the well could naturally flow with, therefore artificial lift would be required to initiate and assist production through most of the life of the field.

Based on the predicted gas production profile, 48 wells would be required for the deepwater GH development. For the conventional gas case, it was assumed that 18 wells would be required, but it is noted that this well count could be significantly reduced in prolific offshore gas fields. Figure 22 presents the total gas production forecast for both cases.

Full discussion of these evaluations cannot be presented here. Additional information on reservoir properties, simulation results, capital and operating costs, and detailed economic discussions are presented in Hancock (2008) and Walsh et al., (2009). Key results from those investigations are summarized in the following discussion.

For the comparative analysis, risked cost and production profiles were developed in order to account for greater uncertainty in a GH development compared to a conventional gas development. Figure 23 illustrates a pre-tax, pre-royalty plot of rate of return versus gas price for the expected results for both the conventional gas and GH developments.

Given the risks associated with conventional deepwater hydrocarbon developments, the GH developments probability adds another level of risk that cannot be quantified at this level of investigation. The capital and operating costs developed for this evaluation considered the unique differences between conventional gas and GH developments and allowed significant contingency to account for these unknowns. While the absolute costs at this level of study have a wide range of uncertainty, the comparative analysis is considered a reasonable indication of the differences between the two types of developments: i.e. while the gas price required to make a GH discovery economic will be higher than that for conventional gas discovery, the difference in price is measured in terms of dollars, not orders of magnitude. This also again illustrates that on a comparable basis, a conventional gas development will be more attractive than a GH development in net present values terms.

**Overview of the economic outlook of production from hydrates.** The results of these investigations, while preliminary, have been very encouraging:

- For onshore gas hydrates, stand-alone developments could be economic with a gas price in the upper range of historical North American prices, and
- For deepwater gas hydrates, stand-alone developments could be economic with a gas price in the upper range of what India has paid for liquefied natural gas imports on the spot market.

As with all hydrocarbon developments, the economics of gas hydrates will be highly variable, depending upon such factors as well performance, sediment type, gas-in-place, thermodynamic conditions of a reservoir, and the access to existing infrastructure. It is also clear that comparable conventional gas reservoirs will generally be economically more attractive than gas-hydrate-only reservoirs, suggesting that the production from gas hydrates on a large commercial scale may be delayed. Unique circumstances may allow production of onshore gas hydrates for local community or industrial use, especially where there is some underlying gas. Offshore GH developments may proceed sooner if the premium price required is not onerous, when there is no conventional gas competition, and where security of supply is a major consideration.

Significant scientific and exploration work must be completed before GHs can be considered as a viable source of natural gas. Critical among these tasks remains the validation of reservoir and well performance through extended field tests that demonstrate the ability to produce GHs at commercial rates. The small-scale production experiments conducted at Mallik and Milne Point provided valuable insight into GH reservoir performance. The short-term production test recently conducted at Mallik also demonstrated that gas hydrates can be produced with current technology (Dallimore and Collett, 2005; Dallimore et al, 2008a; 2008b). The long-term production test planned for the North Slope of Alaska (Collett and Boswell, 2009) is an important step in achieving this goal.

The work conducted to date on GH development and economics is considered preliminary at this time. Cost estimates done at this stage of a development plan are typically assumed to have an accuracy of +40% to -25%. Production forecasts used for the GH developments considered in these studies have been based on theoretical numerical simulation models that have been calibrated only to the short-term tests conducted at Mallik and Mt. Elbert. To date there has been no long term or high rate gas tests to demonstrate GH production potential. Lastly, almost all developments have a degree of geological uncertainty with respect to reservoir extent and variation in properties such as  $\phi$ ,  $k$ , and thickness. In addition, proximity to existing infrastructure and processing facilities can have a significant effect on capital and operating costs.

All of these factors contribute to a wide range of uncertainty with respect to capital costs, revenues, and gas recovery, which therefore results in a wide range of gas prices required for the economic development of gas hydrates. In other words there is no single gas price at which GHs can be declared to be economic. Each field development, conventional or unconventional, must stand on its own technical and economic merit.

Many corporations also have widely varying criteria for economic evaluation, and differing risk tolerance. Most of the companies that work frontier or offshore deepwater projects are also large in nature, and have a large inventory of prospects for exploration and development – GHs will have to be competitive with these projects in order to attract funds.

Forecasting oil and gas prices have proven to be a difficult task, even for those who specialize in this type of work. While these price forecasts may be interesting for macro type economic studies, most oil companies take a very conservative approach to prices for evaluating the economics of any development. For example, the current price of oil is ~\$70/barrel, and has ranged to well over \$100/barrel in the recent past. However, the economics of deepwater developments in the Gulf of Mexico are still typically evaluated with a price forecast of \$35/barrel to \$38/barrel. This is done because, in addition to the uncertainty discussed above, the stability of commodity prices over the life of a project is a major risk that must be considered.

The studies on very few examples of GH development suggest that reasonable returns on investment can be achieved with prices in the order of \$6.00 to \$12.00/thousand standard cubic feet for offshore and onshore projects respectively. However, considering the risks and uncertainties discussed above, sustained gas contract prices in the range of \$10.00 to \$16.00/thousand standard cubic feet for offshore and onshore projects respectively may be required before GH projects will proceed. Lastly, fundamental changes in the North American gas market supply picture, as well as advances in technology may have a significant impact on the price range required for GH development.

### **Environmental Challenges Associated With Gas Production From Hydrates**

A fundamental barrier to the potential utilization of methane from gas hydrates to serve future energy needs relates to our current limited understanding of the GH potential response to production activities and the associated environmental impacts. These impacts will include many issues that typically face current oil and gas exploration and production activities; including ground subsidence related to production from shallow, unconsolidated reservoirs, land and air impacts from drilling and production activities, and disposal of produced waters. Full assessment of these impacts will require a better grasp of the nature of gas hydrate productivity and the types and density of wells, and nature of any downhole formation stimulation that will be needed to enable commercial production. Ultimately, despite the fact that GHs may be a major new source of clean-burning, virtually pure methane gas, it will remain difficult to expect public acceptance of large-scale gas hydrate production in the absence of a larger understanding of the GH role in the natural environment. This is particularly the case given the recognition that naturally occurring GH could provide a potentially deleterious feedback to ongoing climate change.

Gas hydrate is known to be an enormous storehouse of organic carbon with profound potential linkages to global carbon cycling and global climate (Dickens, 2003; Archer, 2007). Although gas hydrate is not considered to be a significant source for atmospheric greenhouse gases at present (IPCC, 2007), there are clearly events in geologic history where significant releases of methane from gas hydrate have likely impacted global climates (e.g. Dickens et al., 1995). This impact is facilitated by the fact that, while its residence time in the atmosphere is limited; over that lifetime, methane gas is approximately 20 times more effective than CO<sub>2</sub> in terms of its overall “greenhouse effect” (IPCC, 2007). However, the geologic and climatic conditions that favor the widespread and large-scale release of methane from gas hydrate deposits, as well as the processes by which such released methane traverses the sediment (Jain and Juanes, 2009) and the water column and therefore reaches the atmosphere, is not well understood. Recent reports suggest that ongoing methane release from marine gas hydrates (particularly at high latitudes) may be linked to warming climates (Paull et al., 2007; Westbrook et al., 2009; Reagan and Moridis, 2009), although the historical baseline data needed to confirm such conclusions are limited. Certainly, the linkage between gas hydrate and climate is complex: recent data contradict previous concepts of gas hydrate as a major participant in Quaternary climate events (in particular, the abrupt terminations of glacial periods), as isotopic data from ice cores suggest that terrestrial (wetlands) sources are most likely responsible for all excess atmospheric methane



associated with these events (Sowers, 2006; Petrenko, et al., 2009). It now appears likely that only the most significant historic climate episodes, such as the Paleocene-Eocene Thermal Maximum (PETM), may have meaningful gas hydrate-related feedbacks, although even in that case, the data are open to various interpretations (Dickens, 2008).

Gas hydrate-climate feedbacks relate to significant, but relatively modest changes in temperature (related to changes in ocean bottom temperature derived from both modification in average air temperature and changes in ocean circulation patterns) and pressure (related to changes in mean global sea-level due to fluctuations in ice volumes). These changes are regional to global in scope, and active for long periods of time (thousands of years), providing opportunities to those perturbations to propagate deep into the subsurface. This scenario is very different from that in play during potential production applications, where very large pressure and temperature perturbations would be imposed on very small areas over extremely short periods of time. Furthermore, there is a fundamental distinction between those deposits that are most closely coupled to climate affects and those that are the likely targets of gas hydrate exploitation. At present, the targets of gas hydrate production research are those accumulations that are housed in sand reservoirs and that are the most deeply buried beneath the surface in Arctic regions or the sea-floor in marine environments. This represents perhaps a significant resource volume, but is likely a very small percentage of the total in-place volume of methane associated with gas hydrates (Boswell, 2009). Therefore, the most critical work to be done will be to assess the real potential impacts associated with only this small subset of resources that occupy the peak of the total gas hydrate resource pyramid (Boswell and Collett, 2006).

As noted by Moridis et al., (2009), gas hydrate production research favors those sand reservoirs that exist deeply buried in the subsurface. Such deposits are closer to the gas sources, closer to the stability conditions for gas hydrate (less energy input require to dissociate them) and housed in sediments of increased mechanical integrity. This latter issue not only serves to reduce the propensity for sand production in the formation, but also increases the potential integrity of the overlying sealing lithologies. These targets, being the “sweet-spots” of high resource density, typically represent isolated units of enhanced permeability (sand layers) that are enclosed within low-permeability sediments. This setting renders the deposits amenable to production through standard borehole-based techniques, utilizing drilled wells to access and dissociation the gas hydrate in situ. As such, environmentally invasive approaches, such as mining of sea-floor and shallow sub-sea-floor deposits is not a consideration within the major national gas hydrate research programs. In addition, such sea-floor harvesting would be unacceptable as surficial gas hydrate masses are known to host complex and as yet poorly understood biological communities. Therefore, those gas hydrates that are most closely coupled to the atmosphere-ocean system (surficial and very shallow disseminated occurrences) and therefore most sensitive to climate change, are not the targets of gas hydrate production research.

One concern that is typically voiced relates to the overall “instability” of gas hydrates. This instability is not unique to gas hydrates, as every material is subject to phase change given appropriate changes in environmental conditions (particularly pressure and temperature). However, this issue has gained added currency in gas hydrate discussions because gas hydrates cannot exist at surface conditions, thereby requiring advanced pressure coring technologies to collect samples for lab analysis. Nonetheless, there is a concern that once hydrate dissociation is initiated in the subsurface, that it will proceed in an uncontrollable “chain reaction.” However, one unique feature of gas hydrates is that the phase transition reaction (from solid hydrate to liquid gas and free water) is self-limiting. The reaction, being endothermic, removes heat from the surrounding environment, thereby reducing ambient temperatures and pushing the region back toward hydrate stability conditions. Therefore, a key challenge with gas hydrate production is not controlling or stopping the reaction, but keeping it going. In fact, it is anticipated that the continuous input or periodic re-application of energy inputs will be required to maintain production (Moridis et al., 2007a;b). Furthermore, numerical simulations of natural gas hydrate systems have shown that the nature of the gas hydrate dissociation reaction will serve to quickly halt dissociation once the depressurizing perturbation is released (Moridis et al., 2009b). Therefore, the prospects for gas hydrate production to result in uncontrolled dissociation reactions are very limited.

One issue that clearly deserves attention is the ability of the lithologic seal overlying gas hydrate-bearing sand reservoirs to contain the dissociated gas. For shallow and unconsolidated reservoirs, failure of the top seal is an issue that may need to be carefully managed such that gas is drawn toward the production well (where pressure gradients will be directed) and not vertically into the overlying sediments. Therefore, all responsible production test scenarios currently envisioned include plans to actively monitor the movement of the dissociation front during and subsequent to testing, so that this and other phenomena can be better understood (Yamamoto and Nagakubo, 2009; TCT, 2006).

Gas hydrate exploration and production activities will be prone to many of the same potential environmental impacts as conventional oil and gas production. A key issue will be ground subsidence: in the marine setting, this may mean assessing the risk for seafloor failure on slopes or other issues that may compromise the integrity of sea-floor infrastructure. In the arctic, this relates to preserving the integrity of the permafrost. Careful selection of drill sites and management of production processes, such as sand control procedures, are expected to be adequate to address such issues. Another issue may be water disposal. Gas hydrate production may result in significant volumes of produced water. Although the dissociated hydrate water will be virtually fresh, there will be an inevitable mixing with formation waters that will result in the production of brackish, unpotable water. Such water will need to be handled and disposed of properly. However, none of these issues are unique to gas hydrates – and methods are currently being employed in a variety of settings to deal with even more acute impact issues.

## Summary

The current paper complements the Moridis et al. (2009) review of the status of the effort toward commercial gas production from gas hydrates. Its objectives are to describe the concept of the gas hydrate petroleum system, to discuss advances, requirement and suggested practices in gas hydrate prospecting and GH deposit characterization, and to review the challenges and uncertainties facing commercial gas production from hydrates. These challenges touch upon a wide range of technical, economic and environmental issues:

The determination of what share of gas-in-place resources will ultimately be rendered recoverable is central to determining the prospects for GH energy supply potential. Recent work clearly has shown that GH resources exist in a variety of play types and that of these play types, GH housed in sand are the the most favorable resource targets. Since 2008, resource assessment of GH in this mode has occurred in Japan, the Gulf of Mexico and the Alaska North Slope, with substantial potential resources identified. Notably, the Alaska assessment also provided the first official assessment of recoverable resource volumes.

Recent drilling programs in Alaska and the Gulf of Mexico were the first to utilize an integrated geological-geophysical “Petroleum Systems” approach in the delineation of GH resource prospects prior to drilling. Positive results indicated the effectiveness of utilizing existing exploration concepts tailored as appropriate for GH applications.

Exploration programs will desire increasing efficiency in the sampling of hydrate-bearing sediments, in sample analysis, and interpretation of the results. Great progress in pressure-coring technologies have been made, and laboratory studies are clarifying the relevance of natural samples versus synthetic samples.

Only a small amount of field production data yet exists. These programs have yielded great insight into the petrophysical nature of in situ GH reservoirs. Further, and particularly longer-term field production testing programs are clearly required to fully understand production potential. Release of data from the 2002 Mallik test and the 2007 Mount Elbert test have provided a means to further advance well test data procedures, and to improve the numerical models that are used to predict well performance, to plan well tests, and to evaluate field test results.

In addition to productivity, a key element in evaluating production from GH will be appraisal of operational risks related to geomechanical and reservoir/well stability. Initial studies are investigating issues such as sand production, fines migration, well-bore collapse, ground subsidence, and seal integrity, and suggest that such issues are not substantially different in nature from those currently managed in oil and gas production, although they may be unique co-present in gas hydrate projects.

With additional experience in reservoir testing, concepts in GH well design, operation and installations appropriate for the particularities of GH systems will mature. Given the many issues facing GH, including water production, obtaining commercial rates, gas lift, flow assurance, sand control and others, it is clear that GH wells will require complex well designs.

The evaluation of the commercial feasibility of GH production is at a very early stage. Ultimate determination of project economics will require further information with respect to all of the above issues. Despite the uncertainties, it is clear that gas hydrate projects will always be less competitive than comparable conventional gas projects where such opportunities exist in the same regions. However, the latest information suggests that margin may only be on the scale of a few dollars.

The monitoring of field tests will be critical to understanding the physical processes of reservoir-scale dissociation, geomechanical response, ultimate production potential, and possible environmental impact of large-scale GH production. Such monitoring will need to incorporate 4-D geophysical monitoring of the dissociation front and movement of released gas, as well as rely on establish monitoring technologies relative to air quality, water disposal, ground-subsidence, etc.

Recent field programs are revealing substantial occurrences of gas hydrate in forms (most notably thick zones of marine clays hosting complex networks of GH veins, nodules) for which production concepts have not been offered and fully evaluated. Extending the analysis of production potential to such settings is warranted, and may become a high priority in those regions where sand-dominated GH reservoirs may be relatively rare.

Full understanding of field test results, regardless of reservoir type and configuration, will continue to rely on laboratory investigations and practices that will provide controlled investigations of many key remaining fundamental knowledge gaps with respect to the behavior of GH and the interaction of GH with sediments.

## Nomenclature

- $k$  = intrinsic permeability ( $m^2$ )
- $k_{eff}$  = effective permeability ( $m^2$ )
- $k_{rA}$  = relative permeability of the aqueous (water) phase
- $k_{rG}$  = relative permeability of the gas phase
- $N_H$  = hydration number
- $P$  = pressure (Pa)
- $S$  = phase saturation
- $t$  = time (days)
- $T$  = temperature (K or °C)
- $TCF$  =  $10^{12}$  STP  $ft^3$  of gas
- $V$  = seismic velocity

## Greek Symbols

$\phi$  = porosity

## Subscripts and Superscripts

$0$  = denotes initial state

$A$  = aqueous phase

$e$  = equilibrium conditions

$cap$  = capillary

$G$  = gas phase

$G0$  = initial gas phase

$H$  = solid hydrate phase

$H0$  = initial solid hydrate phase

$irG$  = irreducible gas

$irA$  = irreducible aqueous phase

$P$  = P-wave (compression)

$R$  = rock

$S$  = S-wave (shear)

## Acknowledgments

The contributions of G.J. Moridis, T. Kneafsey, J. Rutqvist, M.B. Kowalsky and M.T. Reagan were supported by the Assistant Secretary for Fossil Energy, Office of Natural Gas and Petroleum Technology, through the National Energy Technology Laboratory, under the U.S. Department of Energy, Contract No. DE-AC02-05CH11231. The authors are indebted to Stefan Finsterle, John Apps and Dan Hawkes for their insightful comments.

## References

- Anderson, B., Dubourg, I., Collett, T.S., Lewis, R.E. 2005. Modelling the response of the cased hole formation resistivity tool in order to determine the depth of gas hydrate dissociation during the thermal test, in *Scientific Results from the Mallik 2002 Gas Hydrate Production Research Well Program, Mackenzie Delta, Northwest Territories, Canada*, (ed.) S.R. Dallimore and T.S. Collett; Geological Survey of Canada, Bulletin **585**.
- Anderson, B., Hancock, S., Wilson, S., Enger, C., Collett, T., Boswell, R., Hunter, R., 2010a. Formation pressure testing at the Mount Elbert Gas Hydrate Stratigraphic Test Well, Alaska North Slope: Operational summary, history matching, and interpretations. *Journal of Marine and Petroleum Geology* **27** (10).
- Anderson, B., Kurihara, M., White, M., Moridis, G., Wilson, S., Pooladi-Darvish, M., Gaddipati, M., Masuda, Y., Collett, T., Hunter, R., Narita, H., Rose, K., Boswell, R., 2010b. Regional long-term production modeling from a single well test, Mount Elbert Gas Hydrate Stratigraphic Test Well, Alaska North Slope. *Journal of Marine and Petroleum Geology* **27** (10)
- Archer, D., 2007. Methane hydrate stability and anthropogenic climate change. *Biogeosciences* **4**: 521–544.
- Ballard, A.L., Sloan, E.D. 2000. The next generation of hydrate prediction: an overview. *J. Supramolecular Chemistry* **2**: 385-392.
- Bellefleur, G., Riedel, M., Brent, T. 2006. Seismic characterization and continuity analysis of gas hydrate horizons near Mallik research wells, Mackenzie Delta, Canada. *The Leading Edge* **25** (5): 599-606.
- Berge, L.L., Jacobsen, K.A., Solstad, A., 1999. Measured acoustic wave velocities of R11 (CC13F) hydrate samples with and without sand as a function of hydrate concentration. *J. Geophys. Res.*, **104**(B7), 15415–15424, doi:10.1029/1999JB900098.
- Bishnoi, P.R., Gupta, A.K., Englezos, P., Kalogerakis, N. 1989. "Multiphase Equilibrium Flash Calculations for Systems Containing Gas Hydrates. *Fluid Phase Equilibria* **53**: 97-104.
- Bishnoi, P.R., Natarajan, V. 1996. Formation and decomposition of gas hydrates. *Fluid Phase Equilibria* **117**: 168.
- Boswell, R., 2009. Is gas hydrate energy within reach? *Science* **325**: 957-958.
- Boswell, R., Collett, T., 2006, The gas hydrates resource pyramid; Fire in the Ice Newsletter, U.S. DOE – Office of Fossil Energy, Fall 2006, 1-5.
- Boswell, R., Collett, T., 2010. Current status of gas hydrate resources. *Energy and Environmental Science*, doi: 10.1039/c0ee00203h.
- Boswell, R., Collett, T., Anderson, B., Hunter, R., eds., 2010a, Scientific results of the Mount Elbert gas hydrate stratigraphic test well, Milne Point Unit, Alaska North Slope. *J. Marine Pet. Geo.* **27** (10)
- Boswell, R., Collett, T., McConnell, D., Frye, M., Shedd, B., Mrozewski, S., Guerin, G., Cook, A., Shelander, D., Dai, J., Godfriaux, P., Dufrene, R., Jones, E., Roy, R., 2010b. Gulf of Mexico Gas Hydrate Joint Industry Project: Overview of Leg II LWD results. Paper OTC-20560, *Proceedings of the 2010 Offshore Technology Conference*, 3-6 May 2010, Houston, Texas, USA.
- Boswell, R., Hunter, R., Collett, T.S., Digert, S., Hancock, M., Weeks, M. 2008. Investigation of gas hydrate bearing sandstone reservoir at the Mount Elbert stratigraphic test well, Milne Point, Alaska. *Proc. 6th International Conference on Gas Hydrates*, July 6 – 10, 2008, Vancouver, BC.
- Boswell, R., Shelander, D., Lee, M., Latham, T., Collett, T., Guerin, G., Moridis, G., Reagan, M., Goldberg, D., 2009. Occurrence of gas hydrate in Oligocene Frio sand: Alaminos Canyon Block 818: Northern Gulf of Mexico, *Journal of Marine and Petroleum Geology*, **26**(8): 1499-1512, doi:10.1016/j.marpetgeo.2009.03.005.
- Bumb, A.C., Mckee, C.R., 1988. Gas-Well Testing in the Presence of Desorption for Coalbed Methane and Devonian Shale. SPE-FE **March**: 179-185, 1988

- Chiaromonte, L., Kowalsky, M. B., Rutqvist, J., Moridis, G. J. 2009. Design of a potential long-term test of gas production from a hydrate deposit at the PBU-L106 site in North Slope, Alaska: Geomechanical system response and seismic monitoring. *Eos Trans. AGU.* **90** (52), Fall Meet. Suppl., Abs. OS24A-08
- Clarke, M., Bishnoi, P.R., 2001. Determination of the activation energy and intrinsic rate constant of methane gas hydrate decomposition. *Canadian J. Chem. Eng.* **79** (1): 143-147.
- Collett, T.S., 1993. Natural gas hydrates of the Prudhoe Bay and Kuparuk River area, North Slope, Alaska. *AAPG Bull.* **77** (5): 793-812.
- Collett, T.S., 1995. Gas hydrate resources of the United States, in Gautier, D.L., Dolton, G.L., Takahashi, K.I., and Varnes, K.L., eds., 1995 *National assessment of United States oil and gas resources on CD-ROM*: U.S. Geological Survey Digital Data Series **30**.
- Collett, T.S., 2002. Energy resource potential of natural gas hydrates. *AAPG Bull.* **86** (11): 1971-1992.
- Collett, T.S., Lee M., 2005. Electrical resistivity well-log analysis of gas hydrate saturations for the JAPEX/JNOC/GSC et al. Mallik 5L-38 Gas Hydrate Production Research Well, in *Scientific Results from the Mallik 2002 Gas Hydrate Production Research Well Program, Mackenzie Delta, Northwest Territories, Canada*, (ed.) S.R. Dallimore and T.S. Collett; Geological Survey of Canada, Bulletin **585**.
- Collett, T.S., Lewis, R.E., Dallimore, S.R., 2005. Mallik 5L-38 gas hydrate production research well downhole well-log and core montages for the JAPEX/JNOC/GSC et al. Mallik 5L-38 Gas Hydrate Production Research Well, in *Scientific Results from the Mallik 2002 Gas Hydrate Production Research Well Program, Mackenzie Delta, Northwest Territories, Canada*, (ed.) S.R. Dallimore and T.S. Collett; Geological Survey of Canada, Bulletin **585**.
- Collett, T.S., 2008a. Arctic gas hydrate energy assessment studies. *Proc. The Arctic Energy Summit*. Anchorage, Alaska, 2007-2008.
- Collett, T. et al., 2008b. Indian national gas hydrate program expedition 01 initial reports: Expedition 01 of the Indian National Gas Hydrate Program from Mumbai, India to Chennai, India; Sites NGHP-01-01 through NGHP-01-21, April 2006 - August 2006, Directorate General of Hydrocarbons, Ministry of Petroleum and Natural Gas (India), Noida, India.
- Collett, T.S., Riedel, M., Cochran, J.R., Boswell, R., Kumar, P., Sathe, A.V., and the NGHP Expedition 01 Scientific Party, 2008c. Indian continental margin gas hydrate prospects: results of the Indian National Gas Hydrate Program (NGHP) Expedition 01. *Proc. 6th International Conference on Gas Hydrates*, 6-10 July 2008, Vancouver, British Columbia, Canada, <http://hdl.handle.net/2429/1035>.
- Collett, T.S., W.F. Agena, M.W. Lee, M.V. Zyrianova, K.J. Bird, T.C. Charpentier, D.W. Houseknect, T.R. Klett, R.M. Pollastro C.J. Schenk, 2008d. Assessment of gas hydrate resources on the North Slope, Alaska, 2008. USGS Fact Sheet 2008-3073, **4**, <http://pubs.usgs.gov/fs/2008/3073/>.
- Collett, T., Boswell, R., 2009. The selection of drill sites for extended term production testing in Alaska. *DOE-NETL Fire in the Ice Newsletter*, Summer, 2009.
- Collett, T., Boswell, R., Frye, M., Shedd, W., Godfriaux, P., Dufrene, R., McConnell, D., Mrozewski, S., Guerin, G., Cook, A., Jones, E., Roy, R., 2010. Gulf of Mexico Gas Hydrate Joint Industry Project: Logging-while-drilling operations and challenges. Paper OTC 20452, *Proceedings of the 2010 Offshore Technology Conference*, 3-6 May 2010, Houston, Texas, USA.
- CADOEMHRD (Committee on Assessment of the Department of Energy's Methane Hydrate Research and Development), 2010. *Realizing the Energy Potential of Methane Hydrate for the United States*, The National Academies Press, Washington, DC.
- Cook, A.E., Goldberg, D., Kleinberg, R.L. 2008. Fracture-controlled gas hydrate systems in the northern Gulf of Mexico. *Marine and Petroleum Geology* **25**(9): 932-941, doi:10.1016/j.marpetgeo.2008.01.013.
- Cortes, D.D., Martin, A.I., Yun, T.S., Francisca, F.M., Santamarina, J.C., Ruppel, C. 2009. Thermal Conductivity of Hydrate-Bearing Sediments. *J. Geophys. Res.* **114**, B11103, doi:10.1029/2008JB006235.
- Dai, J., H. Xu, F. Shyder, and N. Dutta, 2004. Detection and estimation of gas hydrates using rock physics and seismic inversion: Examples from the northern deepwater Gulf of Mexico. *The Leading Edge* **23**: 60-66.
- Dai, J., F. Snyder, D. Gillespie, A. Koesoemadinata, N. Dutta, 2008. Exploration for gas hydrates in the deepwater northern Gulf of Mexico, Part I: A seismic approach based on geologic model, inversion, and rock physics principals. *Mar. Pet. Geo.* **25**: 845-859.
- Dai, S., Lee, C.H., Santamarina, J.C. 2010. Mount Elbert Sediments (With and Without Hydrates): Characteristics, Mechanical Properties and Geophysical Parameters, submitted to *Mar. Pet. Geo.*
- Dallimore, S.R., Collett, T.S., 2005. Summary and Implications of the Mallik 2002 Gas Hydrate Production Research Well Program. Scientific Results from the Mallik 2002 Gas Hydrate Production Research Well Program, Mackenzie Delta, Northwest Territories, Canada, (ed.) S.R. Dallimore and T.S. Collett; Geological Survey of Canada, Bulletin **585**.
- Dallimore, S.R., Wright, J.F., Nixon, F.M., Kurihara, M., Yamamoto, K., Fujii, T., Fujii, K., Numasawa, M., Yasuda, M., Imasato, Y., 2008a. Geologic and porous media factors affecting the 2007 production response characteristics of the JOGMEC/NRCAN/AURORA Mallik Gas Hydrate Production Research Well. *Proc. 6th International Conference on Gas Hydrates*, 6-10 July 2008, Vancouver, British Columbia, Canada.
- Dallimore, S. R., J. F. Wright, K. Yamamoto, 2008b. Appendix D: Update on Mallik, in Energy from gas hydrates. *Assessing the opportunities and challenges for Canada*: Ottawa, Canada, Council of Canadian Academies, 196-200. [http://www.scienceadvice.ca/documents/\(2008-11-05\)%20Report%20on%20GH.pdf](http://www.scienceadvice.ca/documents/(2008-11-05)%20Report%20on%20GH.pdf)
- Davies, S. R., Selim, M. S., Sloan, E. D., Bollavaram, P., Peters, D. J. 2006. *AIChE Journal* **52** (12): 4016.
- Demer, L. 2009. Spill is One of Worst on the North Slope. <http://www.adn.com/money/industries/oil/prudhoe/story/1046914.html>.
- Dickens, G., 2003. Rethinking the global carbon cycle with a large, dynamic, and microbially mediated gas hydrate capacitor. *Earth & Planetary Sci. Lett.* **213**: 169-183.
- Dickens, G., 2008. Methane release from gas hydrates during the Paleocene-Eocene Thermal Maximum: current perspective on the issue: *DOE-NETL Fire in the Ice*, Summer 2008: 9-12.
- Dickens, G., O'Neil, J., Rea, D., Owen, R., 1995. Dissociation of oceanic methane hydrate as a cause of carbon isotope excursion at the end of the Paleocene. *Paleoceanography* **10**: 965-971.
- Dvorkin, J., Prasad, M., Sakai, A. 1999. Elasticity of marine sediments: Rock physics modeling. *Geophys. Res. Lett.* **26** (12): 1781-1784.
- Dvorkin, J., Uden, R., 2006. The challenge of scale in seismic mapping of hydrate and solutions. *The Leading Edge* **25** (5): 637-643.
- Edwards, R.N., 1997. On the resource evaluation of marine gas hydrate deposits using a seafloor transient electric dipole-dipole method, *Geophysics*, **62**, 63-74.

- Francisca, F.M., Yun, T.S., Ruppel, C.D., Santamarina, J.C. 2005. Geophysical and geotechnical properties of near-surface sediments in the northern Gulf of Mexico gas hydrate province. *Earth & Planetary Sci. Lett.* **237**: 924-939.
- Freifeld, B.M., Kneafsey, T.J., 2004. *Investigating methane hydrate in sediments using X-ray computed tomography*. In *Advances in the Study of Gas Hydrates*. Kluwer Academic/Plenum Press, p. 227-238, LBNL-55030
- Freij-Ayoub, R., Tan, C., Clennell, B., Tohidi, B., Yang, J. 2007, A wellbore stability model for hydrate bearing sediments, *Journal of Petroleum Science and Engineering*, **57**(1-2), 209-220, doi: 10.1016/j.petrol.2005.10.011.
- Frye, M., 2008. Preliminary evaluation of in-place gas hydrate resources: Gulf of Mexico Outer Continental Shelf. *Minerals Management Service Report 2008-004*. <http://www.mms.gov/revaldiv/GasHydrateAssessment.htm>.
- Frye, M., Shedd, W., Godfriaux, P., Dufrene, R., Collett, T., Lee, M., Boswell, R., Jones, E., McConnell, D., Mrozewski, S., Guerin, G., Cook, A., 2010. Gulf of Mexico Gas Hydrate Joint Industry Project Leg II: Results from the Alaminos Canyon 21 Site, Paper OTC-20560, *Proceedings of the 2010 Offshore Technology Conference*, 3-6 May 2010, Houston, Texas, USA.
- Fujii, K., Yasuda, M., Cho, B., Ikegami, T., Sugiyama, H., Imasato, Y., Dallimore, S.R., Wright, J.F., 2008, Development of a monitoring system for the JOGMEC/NRCan/Aurora Mallik gas hydrate production test program. *Proc. 6th International Conference on Gas Hydrates*, July 6 – 10, 2008, Vancouver, BC.
- Fujii et al., 2008... Fujii, T., Saeki, T., Kobayashi, T., Inamori, T., Hayashi, M., Takano, O., Takayama, T., Kawasaki, T., Nagakubo, S., Nakamizu, M., Yokoi, K. 2008. Resource assessment of methane hydrate in the eastern Nankai Trough, Japan: *Proceedings*, 6<sup>th</sup> International Conference on Gas Hydrates (ICGH-6).
- Gerami, S. and Pooladi-Darvish, M. 2007a. Predicting Gas Generation by Depressurization of Hydrates where the Sharp-Interface Assumption is not Valid. *J. Pet. Sci. Eng.* **56** (1-3): 146-164.
- Gerami, S. and Pooladi-Darvish, M. 2007b. Effect of Hydrates on Sustaining Reservoir Pressure in a Hydrate-Capped Gas Reservoir. *J. Canadian Petroleum Technology* **46** (10): 39-48.
- Gerami, S., Pooladi-Darvish, M. 2009. An Early-Time Model for Drawdown Testing of a Hydrate-Capped Gas Reservoir. *SPE Res. Eval. Eng.* **12** (4): 596-609.
- Ghezzehei, T. A., Kneafsey, T. J., 2010, Measurements of the Capillary Pressure-Saturation Relationship of Methane Hydrate Bearing Sediments, Paper OTC 20550, *Proceedings*, 2010 Offshore Technology Conference, Houston, Texas, USA. doi.10.4043/20550-MS
- Graue, S., Kvamme, B., Baldwin, B.A., Stevens, J., Howard, J., Aspenes, E., Erslund, G., Husebo, J., Zomes, D., M. 2008. MRI Visualization of Spontaneous Methane Production From Hydrates in Sandstone Core Plugs When Exposed to CO<sub>2</sub>. *SPE J.* **13**(2): 146-152, (doi: 10.2118/118851-PA).
- Guerin, G., Goldberg, D., Collett, T.S., 2005. Sonic attenuation in the JAPEx/JNOC/GSC et al. Mallik 5L-38 gas hydrate production research well, in *Scientific Results from the Mallik 2002 Gas Hydrate Production Research Well Program*, Mackenzie Delta, Northwest Territories, Canada, (ed.) S.R. Dallimore and T.S. Collett; Geological Survey of Canada, Bulletin **585**.
- Gullapalli, I., Moridis, G.J., Silpngarmert, S., Reik, B., Kamal, M., Jones, E., Collett T. 2008, Designing a Reservoir Flow Rate Experiment for the GOM Hydrate JIP Leg II LWD Drilling, *Proceedings*, 6<sup>th</sup> International Conference on Gas Hydrates, Vancouver, British Columbia, Canada, July 6-10, 2008.
- Gupta, A. et al., 2006. Composite thermal conductivity in a large heterogeneous porous methane hydrate sample. *J. Phys. Chem. B.* **110** (33): 16384-16392.
- Hadley, C., Peters, D., Vaughan, A., Bean, D., 2008. Gumusut-Kakap Project: Geohazard Characterisation and Impact on Field-Development Plans, IPTC 12554-MS, International Petroleum Technology Conference, Kuala Lumpur, 3–5 December 2008.
- Hammerschmidt, E.G. 1934. Formation of Gas Hydrates in Natural Gas Transmission Lines. *Ind. & Eng. Chem.* **26** (8): 851.
- Hancock S., Okazawa, T., and Osadetz, K. 2005. A Preliminary Investigation of the Economics of Onshore Gas Hydrate Production, *Proc. 7th Annual Conference on Unconventional Gas*, Calgary, Alberta, Nov. 2005.
- Hancock, S.H., Dallimore, S.R., Collett, T.S., Carle, D., Weatherhill, B., Satoh, T., Inoue, T. 2005. Overview of pressure draw-down production-test results for the JAPEx/JNOC/GSC et al. Mallik 5L-38 gas hydrate production research well. *Scientific Results from the Mallik 2002 Gas Hydrate Production Research Well Program*, Mackenzie Delta, Northwest Territories, Canada, (ed.) S.R. Dallimore and T.S. Collett; Geological Survey of Canada, Bulletin **585**.
- Hancock S. 2008. Development of Gas Hydrates. *Proc. New Zealand Petroleum Conference*, Auckland, New Zealand, March 2008.
- Handa, Y.P., 1986. Compositions, enthalpies of dissociation, and heat capacities in the range 85 to 270 K for clathrate hydrates of methane, ethane, and propane, and enthalpy of dissociation of isobutane hydrate, as determined by a heat-flow calorimeter. *J. Chem. Thermodynamics* **18** (10): 915-921.
- Handa, Y.P., Stupin, D.Y., 1992. Thermodynamic properties and dissociation characteristics of methane and propane hydrates in 70-ANG-radius silica gel pores. *J. Phys. Chem.* **96** (21): 8599-8603.
- Hardage, B.A., Murray, P., Sava, D., Backus, M., Remington, R., Graebner, R., Roberts, H.H. 2006. Evaluation of deepwater gas-hydrate systems. *The Leading Edge* **25** (5): 572-577.
- Hardage, B.A., Roberts, H. H., Murray, P. E., Remington, R., Sava, D. C., Shedd, W., and Hunt, J. Jr., 2009. Multicomponent seismic technology assessment of fluid-gas expulsion geology, Gulf of Mexico, in Collett, T., A. Johnson, C. Knapp and R. Boswell, eds., *Natural Gas Hydrates: Energy Resource and Associated Geologic Hazards*, The American Association of Petroleum Geologists Memoir **89**.
- Helgerud, M., Dvorkin, J. Nur, A. Sakai, A. Collett, T. 1999. Elastic-Wave Velocity in Marine Sediments with Gas Hydrates: Effective Medium Modeling. *Geophys. Res. Lett.* **26**(13): 2021-2024.
- Holder, G.D., Malone, R.D., Lawson, W.F., 1987. Effects of gas composition and geothermal properties on the thickness and depth of natural-gas-hydrate zone. *J. Pet. Tech.* **39**(9): 1147-1152.
- Hong, H., Pooladi-Darvish, M. 2005. Simulation of Depressurization for Gas Production from Gas Hydrates Reservoirs. *J. Canadian Petroleum Technology* **44**: 39-46.
- Huang, D., Fan, S., 2005. Measuring and modeling thermal conductivity of gas hydrate-bearing sand. *J. Geophys. Res.* **110**.

- Hunter, R., Collett, T., Boswell, R., Anderson, B., Digert, S., Pospisil, G., Baker, R., Weeks, M., 2010. Mount Elbert Gas Hydrate Stratigraphic Test Well, Alaska North Slope: Overview of scientific and technical program. *Journal of Marine and Petroleum Geology*. **27** (10)
- Hutchinson, D., D. Shelander, J. Dai, D. McConnell, W. Shedd, M. Frye, C. Ruppel, R. Boswell, E. Jones, T. Collett, K. Rose, B. Dugan, W. Wood, T. Latham, 2008. Site selection for DOE/JIP gas hydrate drilling in the northern Gulf of Mexico. *Proc. 6th International Conference on Gas Hydrates*. 6-10 July 2008., Vancouver, British Columbia, Canada.
- Hvorslev, M. J. 1949. *Subsurface Exploration and Sampling of Soils for Civil Engineering Purposes*, Waterways Experimental Station., U.S. Army Corps of Eng., Vicksburg, Mississippi, 521 pp.
- Hyndman, R.D., Davis, E.E., 1992. A mechanism for the formation of methane hydrate and seafloor bottom-simulating reflectors by vertical fluid expulsion. *J. Geophys. Res.* **97**: 7025–7041.
- Hyodo, M., Y. Nakata, N. Yoshimoto, and T. Ebinuma (2005), Basic research on the mechanical behavior of methane hydrate sediments mixture, *Soils Found.*, 45, pp. 75–85.
- Inks, T.L., Lee, M.W., Agena, W.F., Taylor, D.J., Collett, T.S., Hunter, R.B., Zyrianova, M.V., 2009. Seismic prospecting for gas hydrate and associated free-gas prospects in the Milne Point area of northern Alaska, in Collett, T., Johnson, A., Knapp, C., Boswell, R., eds, *Natural Gas Hydrates -- Energy Resource Potential and Associated Geologic Hazards: American Association of Petroleum Geologists Memoir* **89**.
- IPCC, 2007. *Climate Change 2007: The Physical Science Basis: Intergovernmental Panel on Climate Change*.
- Itasca Consulting Group Inc, 2009. *FLAC3D Version 4-User's Guide*. Fourth Edition. Itasca Consulting Group, Inc. Minneapolis, Minnesota.
- Jain, A., Juanes, R., 2009. Preferential Mode of gas invasion in sediments: Grain-scale mechanistic model of coupled multiphase fluid flow and sediment mechanics. *J. Geophys. Res.* **114**: B08101.
- Jaiswal, N.J., 2004. Measurement of gas-water relative permeabilities in hydrate systems. MS Thesis, University of Alaska Fairbanks, Fairbanks, AK.
- Katsuki, D., Ohmura, R., Ebinuma, T., Narita, H., 2006. Formation, growth and aging of clathrate hydrate crystals in a porous medium. *The Philosophical Magazine* **86** (12): 1753-1761.
- Katsuki, D., Ohmura, R., Ebinuma, T., Narita, H., 2007. Methane hydrate crystal growth in a porous medium filled with methane-saturated liquid water. *The Philosophical Magazine* **87** (7): 1057-1069.
- Katsuki, D., Ohmura, R., Ebinuma, T., Narita, H., 2008. Visual observation of dissociation of methane hydrate crystals in a glass micro model: Production and transfer of methane. *J. App. Phys.* **104** (8): 083514-9.
- Kerker, P. et al., 2009. Direct observations of three dimensional growth of hydrates hosted in porous media. *App. Phys. Lett.* **95** (2): 024102-3.
- Kim, H.C., Bishnoi, P.R., Heidemann, R.A., Rizvi, S.S.H., 1987. Kinetics of methane hydrate decomposition. *Chem. Eng. Sci.* **42** (7): 1645-1653.
- Klapproth, A., Techmer, K.S., Klapp, S.A., Murshed, M.M., Kuhs, W.F., 2006. Microstructure of gas hydrates in porous media. *Proc. 11th International Conference on the Physics and Chemistry of Ice*. Royal Society of Chemistry, Bremerhaven.
- Klein, K.A., Santamarina, J.C., 2003. Electrical conductivity in soils: Underlying phenomena. *J. Environ. Eng. Geophys.* **8**: 263–273.
- Kleinberg, R.L. et al., 2003. Deep sea NMR: Methane hydrate growth habit in porous media and its relationship to hydraulic permeability, deposit accumulation, and submarine slope stability. *J. Geophys. Res.* **108** (B10): 2508.
- Kleinberg, R.L., Flaum, C., and Collett, T.S. 2005. Magnetic resonance log of JAPEX/JNOC/GSC et al. Mallik 5L-38 gas hydrate production research well: gas hydrate saturation, growth habit, and relative permeability, in *Scientific Results from the Mallik 2002 Gas Hydrate Production Research Well Program, Mackenzie Delta, Northwest Territories, Canada*, (ed.) S.R. Dallimore and T.S. Collett; Geological Survey of Canada, Bulletin **585**.
- Kleinberg, R.L., Flaum, C., Collett, T.S. 2005. Magnetic resonance log of JAPEX/JNOC/GSC Mallik 5L-38 gas hydrate production research well: gas hydrate saturation, growth habit, and relative permeability. *Scientific Results from the Mallik 2002 Gas Hydrate Production Research Well Program, Mackenzie Delta, NWT, Canada*, (ed.) S.R. Dallimore and T.S. Collett, Geological Survey of Canada, Bulletin **585**.
- Kneafsey, T.J. et al., 2007. Methane Hydrate Formation and Dissociation in a Core-Scale Partially Saturated Sand Sample. *J. Pet. Sci. Eng.* **56**: 108-126.
- Kneafsey, T.J., Seol, Y., Gupta, A., Tomutsa, L., 2008. Permeability of Laboratory-Formed Methane-Hydrate-Bearing Sand, *Proc. 2008 Offshore Technology Conference*, Houston, 4-8 May 2008.
- Kneafsey, T.J. et al., 2009. Analysis of core samples from the BPXA-DOE-USGS Mount Elbert gas hydrate stratigraphic test well: Insights into core disturbance and handling. *Mar. Pet. Geo.*, doi:10.1016/j.marpetgeo.2009.10.009.
- Kowalsky, M. B., Finsterle, S., Peterson, J., Hubbard, S., Rubin, Y., Majer, E., Ward, A., Gee, G. 2005. Estimation of field-scale soil hydraulic and dielectric parameters through joint inversion of GPR and hydrological data. *Water Resour. Res.* **41**, W11425, doi:10.1029/2005WR004237.
- Kowalsky, M.B., and Moridis, G.J. 2007. Comparison of Kinetic and Equilibrium Reaction Models in Simulating the Behavior of Gas Hydrates in Porous Media, *Journal of Energy Conversion and Management*, **48**(6), 1850-1863, doi: 10.1016/j.enconman.2007.01.017 (LBNL-60361, 2006).
- Kowalsky, M. B., Nakagawa, S., Moridis, G. J., 2010. Feasibility of monitoring gas hydrate production with time-lapse VSP, *SPE Journal*, doi: 10.2118/132508-PA (SPE-132508-PA, LBNL-3091E).
- Kumar, A. et al., 2010. Experimental determination of permeability in the presence of hydrates and its effect on the dissociation characteristics of gas hydrates in porous media. *J. Pet. Sci. Eng.* **70**: 114–122.
- Kurihara, M., Funatsu, K., Kusaka, K., Masuda, Y., Dallimore, S.R., Collett, T.S., Hancock, S.H. 2005. Well-test Analysis of Gas Hydrate Reservoirs: Examination of Parameters suggested by Conventional Analysis for the JAPEX/JNOC/GSC et al. Mallik 5L-38 Gas Hydrate Production Research Well, in *Scientific Results from the Mallik 2002 Gas Hydrate Production Research Well Program, Mackenzie Delta, Northwest Territories, Canada*, (ed.) S.R. Dallimore and T.S. Collett; Geological Survey of Canada, Bulletin **585**.

- Kurihara, M., Funatsu, K., Ouchi, H., Masuda, Y., Masato, Y., Yamamoto, K., Numasawa, M., Fujii, T., Narita, H., Dallimore, S.R., Wright, F. 2008a. Analysis of the JOGMEC/NRCAN/AURORA Mallik Gas Hydrate Production Test Through Numerical Simulation. *Proc. 6th International Conference on Gas Hydrates*, July 6 – 10, 2008, Vancouver, BC.
- Kurihara, M., Sato, A., Funatsu, K., Ouchi, H., Masuda, Y., Narita, H., Collett, T., 2010.,2010. Analysis of MDT test in Mt. Elbert methane hydrate reservoir through numerical simulation; *Journal of Marine Petroleum Geology*, **27** (10)
- Kurihara, M., Sato, A., Ouchi, H., Narita, H., Ebinuma, T., Suzuki, K., Masuda, Y., Saeki, T., Yamamoto, K., Fujii, T., 2010. Prediction of production test performances in eastern Nankai Trough methane hydrate reservoirs using 3-D reservoir model. Paper OTC 19382, *Proceedings of the 2010 Offshore Technology Conference*, 3-6 May 2010, Houston, Texas, USA.
- Kvenvolden, K.A., 1988. Methane hydrate--A major reservoir of carbon in the shallow geosphere? *Chem. Geo.* **71**: 41-51.
- Kvenvolden, K.A., 1993. A primer in gas hydrates, in Howell, D.G., ed., *The Future of Energy Gases: U.S. Geological Survey Professional Paper 1570*: 279-292.
- Lee, C., Yun, T.S., Lee, J.S., Santamarina, J.C. 2010c. Geotechnical Characterization of Marine Sediments in The Ulleung Basin, East Sea. Submitted to *Marine Geology*.
- Lee, J. Y., 2007. Hydrate-bearing sediments: formation and geophysical properties. Ph.D. Thesis, Georgia Institute of Technology, Atlanta Georgia.
- Lee, J.Y., Yun, T.S., Santamarina, J.C., Ruppel, C. 2007. Observations Related To Tetrahydrofuran and Methane Hydrate for Laboratory Studies of Hydrate-Bearing Sediments. *Geochem. Geophys. Geosys.* **8** (6): Q06003.
- Lee, J.Y., Santamarina, J.C., Ruppel, C., 2008. Mechanical and electromagnetic properties of northern Gulf of Mexico sediments with and without THF hydrates. *Mar. Pet. Geo.* **25** (9): 884-895.
- Lee, J.Y., Santamarina, J.C., Ruppel, C.D. 2010a. Hydrate-Bearing Sand, Silt, and Clay Sediments - Part I: Electromagnetic Properties. Submitted to *J. Geophys. Res.*
- Lee, J.Y., Francisca F., Santamarina, J.C., Ruppel, C.D. 2010b. Hydrate-Bearing Sand, Silt, and Clay Sediments - Part II: Small-strain Mechanical Properties. Submitted to *J. Geophys. Res.*
- Lee, J.Y., Santamarina, J.C., Ruppel, C.D. 2010d. Volume Change During Formation and Dissociation of THF Hydrate in Sediments, *Geochem. Geophys. Geosys.* in press.
- Lee, M. W. 2002. Biot-Gassmann theory for velocities of gas hydrate bearing sediments. *Geophysics* **67**(6):1711-1719.
- Lee, M.W., Collett, T.S., 2005. Assessments of gas hydrate concentrations estimated from sonic logs in the JAPEx/JNOC/GSC et al. Mallik 5L-38 gas hydrate research production well, in *Scientific Results from the Mallik 2002 Gas Hydrate Production Research Well Program, Mackenzie Delta, Northwest Territories, Canada*, (ed.) S.R. Dallimore and T.S. Collett; Geological Survey of Canada, Bulletin **585**.
- Lee, M.W., Waite, W.F., 2008. Estimating pore-space gas hydrate saturations from well log acoustic data, *Geochem. Geophys. Geosyst.*, **9**, Q07008, doi:10.1029/2008GC002081.
- Lee, M.W., Collett, T.S., 2009. Gas hydrate saturations estimated from fractured reservoir at Site NGHP-01-10, Krishna-Godavari Basin, India, *J. Geophys. Res.*, **114**; B07102, doi:10.1029/2008JB006237.
- Lee, M.W., Collett, T.S., 2010... Lee, M., Collett, T., 2010. In-situ gas hydrate hydrate saturation estimated from various well logs at the Mount Elbert Gas Hydrate Stratigraphic Test Well, Alaska North Slope. *Journal of Marine and Petroleum Geology* **27** (10).
- Lee, M., Agena, W., Collett, T., Inks, T., 2009. Pre- and post-drill comparison of the Mount Elbert gas hydrate prospect at the Milne Point area, Alaska North Slope. *Journal of Marine and Petroleum Geology* **27** (10) Lee, M. W., Agena, W. F., Collett, T. S., Inks, T. L. 2010. Pre- and post-drill comparison of the Mount Elbert gas hydrate prospect at the Milne Point area, Alaska North Slope. *Mar. Pet. Geo.*, doi:10.1016/j.marpetgeo.2009.08.007
- Lee, M.W., Collett, T.S., Inks, T.L., 2009. Seismic attribute analysis for gas-hydrate and free-gas prospects on the North Slope of Alaska, in Collett, T., Johnson, A., Knapp, C., Boswell, R., eds, *Natural Gas Hydrates -- Energy Resource Potential and Associated Geologic Hazards: American Association of Petroleum Geologists Memoir 89*.
- Lunne, T., Berre, T., Andersen, K.H., Strandvik, S., Sjørusen, M. 2006. Effects of sample disturbance and consolidation procedures on measured shear strength of soft marine Norwegian clays. *Canadian Geotechnical Journal* **43**: 726-750.
- Makogon, Y.F., 1997. *Hydrates of Hydrocarbons*. Penn Well Publishing Co. Tulsa, OK.
- Makogon, Y., Gazov 1965. *Promst.* **5**: 14.
- Masui, A., Haneda, H., Ogata, Y., Aoki, K., 2005. The effect of saturation degree of methane hydrate on the shear strength of synthetic methane hydrate sediments, *Proc. 5th International Conference on Gas Hydrates*, Trondheim, Norway.
- Masui, A., K. Miyazaki, H. Haneda, Y. Ogata, K. Aoki 2008. Mechanical characteristics of natural and artificial gas hydrate bearing sediments. *Proc. 6th International Conference on Gas Hydrates*, Chevron, Vancouver, B. C., Canada, 6–10 July.
- Masui, A., Miyazaki, K., Haneda, H., Ogata, Y., Aoki, K., 2008. Mechanical Properties of Natural Gas Hydrate Bearing Sediments Retrieved from Eastern Nankai Trough. *Proc. 2008 Offshore Technology Conference*, Houston, 4-8 May 2008.
- Masui, A., Miyazaki, K., Haneda, H., Ogata, Y., Aoki, K., 2008. Mechanical characteristics of natural and artificial gas hydrate bearing sediments. *Proc. 6th International Conference on Gas Hydrates*, Vancouver, British Columbia, Canada, July 6-10, 2008.
- Mattar, L., Zaoral, K. 1992. The Primary Pressure Derivative (PPD) – A New Diagnostic Tool in Well Test Interpretation. *J. Canadian Petroleum Technology* **31**(4): 63-70.
- McConnell, D. R., Kendall, B.A., 2002. Images of the base of gas hydrate stability, northwest Walker Ridge, Gulf of Mexico, Paper OTC 14103, *Proceedings, Offshore Technology Conference*, Houston, Texas, 6-9 May 2002.
- McConnell, D., Collett, T., Boswell, R., Frye, M., Shedd, W., Dufrene, R., Godfriaux, P., Mrozewski, S., Guerin, G., Cook, A., Jones, E., 2010. Gulf of Mexico Gas Hydrate Joint Industry Project Leg II: LWD logging program design, data acquisition, and evaluation. Paper OTC 20801, *Proceedings of the 2010 Offshore Technology Conference*, 3-6 May 2010, Houston, Texas, USA.
- Milkereit, B., Adam, E., Li, Z., Qian, W., Bohlen, T., Banerjee, D., Schmitt, D.R., 2005. Multi-offset vertical seismic profiling: an experiment to assess petrophysical-scale parameters at the JAPEx/JNOC/GSC et al. Mallik 5L-38 gas hydrate production research well, in *Scientific Results from the Mallik 2002 Gas Hydrate Production Research Well Program, Mackenzie Delta, Northwest Territories, Canada*, (ed.) S.R. Dallimore and T.S. Collett; Geological Survey of Canada, Bulletin **585**.



- Minagawa, H. et al., 2005. Water permeability measurements of gas hydrate-bearing sediments, *Proc. 5th International Conference on Gas Hydrates*, Trondheim, Norway.
- Moridis, G.J. 2003. Numerical studies of gas production from methane hydrates, SPE 87330. *SPE J.* **32**: 359-370.
- Moridis, G.J. 2004. Numerical studies of gas production from Class 2 and Class 3 hydrate accumulations at the Mallik Site, Mackenzie Delta, Canada. *SPE Res. Eval. Eng.* **7**:175-183.
- Moridis, G.J., Collett, T.S. 2004. Strategies for Gas Production from Hydrate Accumulations Under Various Geologic Conditions, LBNL-52568, Lawrence Berkeley National Laboratory, Berkeley, CA.
- Moridis, G.J., Seol, Y., Kneafsey, T.J., 2005. Studies of reaction kinetics of methane hydrate dissociation in porous media. *Proc. 5th International Conference on Gas Hydrates*, Trondheim, Norway, Paper 1004, 21-30.
- Moridis, G.J., Kowalsky, M. B. 2007. Response of oceanic hydrate-bearing sediments to thermal stresses. *SPE J.*, **12**(2): 253-268.
- Moridis G.J., and Reagan, M.T. 2007a. Strategies for Production from Oceanic Class 3 Hydrate Accumulations. OTC 18865, *Proc. 2007 Offshore Technology Conference*, Houston, 30 April-3 May 2007.
- Moridis, G.J., Reagan, M.T., 2007b. Gas Production From Oceanic Class 2 Hydrate Accumulations, OTC 18866, 2007 Offshore Technology Conference, Houston, Texas, U.S.A., 30 April-3 May 2007.
- Moridis, G.J., Kowalsky, M.B., Pruess, K., 2007. Depressurization-induced gas production from Class 1 hydrate deposits. *SPE Res. Eval. Eng.* **10** (5): 458-481.
- Moridis, G.J., Sloan, E.D. 2007. Gas Production of disperse low-saturation hydrate accumulations in oceanic sediments. *Energy Conversion and Management* **48**: 1834-1849.
- Moridis, G.J., M. Kowalsky and K. Pruess. 2008. TOUGH+HYDRATE v1.0 User's Manual. LBNL-161E, Lawrence Berkeley National Laboratory, Berkeley, CA.
- Moridis, G.J., Collett, T.S., Boswell, R., Kurihara, M., Reagan, M.T., Sloan, E.D., Koh, C., 2009. Toward production from gas hydrates: assessment of resources and technology and the role of numerical simulation. SPE 114163, *SPE J.*, **12** (5): 745-771.
- Moridis, G.J., Silpngarmert, S., Reagan, M.T., Collett, T., Zhang, K., 2010. Gas production from a cold, stratigraphically bounded hydrate deposit at the Mount Elbert site, North Slope, Alaska. In press, *J. Marine Petr. Geol.*
- Mrozewski, S., Cook, A., Guerin, G., Goldberg, D., Collett, T., Boswell, R., Jones, E., 2010. Gulf of Mexico Gas Hydrate Joint Industry Project Leg II: Results from the GC955 site. Paper OTC 21023, *Proceedings of the 2010 Offshore Technology Conference*, 3-6 May 2010, Houston, Texas, USA.
- Murshed, M.M., Kuhs, W.F. 2009. Title? *J. Phys. Chem. B* **113**: 5172.
- Park, K.-P, Bahk, J.-J., Kwon, Y., Kim, G.-Y., Riedel, M., Holland, M., Schultheiss, P., Rose, K., and the UBGH-1 Scientific Party, 2008. Korean national program expedition confirm rich gas hydrate deposits in the Ullung Basin, East Sea. *DOE-NETL Fire In the Ice*, Spring, 2008: 6-9, [http://www.netl.doe.gov/technologies/oil-gas/publications/Hydrates/Newsletter/HMNews\\_Spring\\_08.pdf#page=6](http://www.netl.doe.gov/technologies/oil-gas/publications/Hydrates/Newsletter/HMNews_Spring_08.pdf#page=6).
- Paul, C., Reeburgh, W.S., Dallimore, S.R., Enciso, G., Green, S., Koh, C.A., Kvenvolden, K.A., Mankin, C., Riedel, M., Eide, E.A. 2010. Realizing the energy potential of methane hydrate for the United States. National Academies NRC Report, National Academies Press.
- Paull, C.K., Ussler, W., Borowski, W.S., Spiess, F.N., 1995. Methane-rich plumes on the Carolina continental rise: Associations with gas hydrates, *Geology*, **23**: 89-92.
- Paull, C.K., Matsumoto, R., Wallace, P.J., eds., 1996. Initial Reports--Gas hydrate sampling on the Blake Ridge and Carolina Rise. *Proc. Ocean Drilling Program*, **164**: 623, Texas A&M University, College Station, Texas.
- Paull, C., Ussler, W., Dallimore, S., Blasco, S., Lorenson, T., Melling, H., Medioli, B., Nixon, F., McLaughlin, F. 2007. Origin of pingo-like features on the Beaufort Sea shelf and their possible relationship to decomposing methane gas hydrates. *Geophys. Res. Lett.* **34**, L01603, doi:10.1029/2006GL027977.
- Petrenko, V., Smith, A., Brook, E., Lowe, D., Riedel, K., Brailsford, G., Hua, Q., Schaefer, H., Reeh, N., Weiss, R., Etheridge, D., Severinghaus, J. 2009. 14CH<sub>4</sub> measurements in Greenland ice: investigating last glacial termination CH<sub>4</sub> sources. *Science* **324**: 506-508.
- Plona, T.J., Kane, M.R. 2005. Anisotropic stress analysis from downhole acoustic logs in the JAPEx/JNOC/GSC et al. Mallik 5L-38 gas hydrate production research well, in *Scientific Results from the Mallik 2002 Gas Hydrate Production Research Well Program, Mackenzie Delta, Northwest Territories, Canada*, (ed.) S.R. Dallimore and T.S. Collett; Geological Survey of Canada, Bulletin **585**.
- Pooladi-Darvish, M., Hong, H. 2004. Effect of Conductive and Convective Heat Flow on Gas Production from Natural Hydrates by Depressurization. *Advances in the Study of Gas Hydrates*, Editors: Charles E. Taylor and Jonathan Kwan, Springer Publishing: 43-65.
- Pooladi-Darvish, M., Hong, H., 2010, Use of MDT Results over a Hydrate Interval at Mt. Elbert for Long Term Production Forecast – Implications of Uncertainties, In press, *Journal of Marine and Petroleum Geology*, 1-11.
- Priest, J.A., Rees, E.V.L. Clayton, C.R.I., 2009. Influence of gas hydrate morphology on the seismic velocities of sands. *J. Geophys. Res.* **114**, B11205, doi:10.1029/2009JB006284.
- Reagan, M., Moridis, G., 2009. Large-Scale Simulation of Methane Hydrate Dissociation along the West Spitsbergen Margin. *Geophys. Res. Lett.* **36**: L23612, doi: 10.1029/2009GL041332.
- Reem Freij-Ayoub, R., Clennell, B., Tohidi, B., Yang, J., Hutcheon, R., Casing Integrity in Hydrate Bearing Sediments. *Proc. 6th International Offshore Site Investigation and Geotechnics Conference*, September 2007, London, UK.
- Riedel, M. R., Bellefleur, G., Mair, S., Brent, T. A., Dallimore, S. R. 2009. Acoustic impedance inversion and seismic reflection continuity analysis for delineating gas hydrate resources near the Mallik research sites. Mackenzie Delta, Northwest Territories, Canada. *Geophysics* **74**: B125, doi:10.1190/1.3159612.
- Riedel, M., Collett, T.S., Malone, M.J., and the Expedition 311 Scientists, 2006a. *Proc. Integrated Ocean Drilling Program*, IODP 311, Washington, D.C., doi:10.2204/iodp.proc.311.2006.
- Riedel, M., Willoughby, E.C. Chen, M.A. He, T., Novosel, I., Schwalenberg, K., Hyndman, R.D., Spence, G.D., Chapman, N.R., Edwards, R.N., 2006b. Gas Hydrate on the Northern Cascadia Margin: Regional geophysics and structural framework, in Riedel, M., Collett, T.S., Malone, M.J. and the Expedition 311 Scientists, *Proc. IODP, 311 : Washington, DC (Integrated Ocean Drilling Program Management Internation, Inc.)* doi:10.2204/iodp.proc.311.109.2005, 2006



- Riedel, M., Willoughby, E., Chopra, S., eds., 2010, *Geophysical Characterization of Gas Hydrates*, Society of Exploration Geophysics, Tulsa, OK.
- Rosenbaum, E., English, N., Johnson, J., Shaw, D. Warzinski, R., 2007. Thermal conductivity of methane hydrate from experiment and molecular simulation. *J. Phys Chem B.* **111** (46): 13194-205.
- Ruppel, C., 2000. Thermal state of the gas hydrate reservoir. *Natural Gas Hydrate: In Oceanic and Permafrost Environments*. M.D. Max (Editor), Kluwer: Dordrecht, Netherlands, 29-42.
- Ruppel, C., Boswell, R., Jones, E., 2008. Scientific results from Gulf of Mexico Gas Hydrates Joint Industry Project Leg 1 Drilling: Introduction and overview. *Mar. Pet. Geo.* **25**(9): 819-829.
- Rutqvist J. and Moridis G. 2008. Development of a Numerical Simulator for Analyzing the Geomechanical Performance of Hydrate-Bearing Sediments, paper 139. *Proc. 42th U.S. Rock Mechanics Symposium*, San Francisco, California, USA, June 29-July 2, 2008.
- Rutqvist, J., Grover, T., Moridis, G.J. 2008. Coupled Hydrological, Thermal and Geomechanical Analysis of Wellbore Stability in Hydrate-Bearing Sediments, OTC 19672, *Proc. 2008 Offshore Technology Conference*, Houston, 4-8 May 2008.
- Rutqvist J. and Moridis G.J. 2009. Numerical Studies on the Geomechanical Stability of Hydrate-Bearing Sediments. SPE 126129. *SPE J.* **14**: 267-282.
- Rutqvist J., Moridis G.J., Grover T., and Collett T. 2009. Geomechanical response of permafrost-associated hydrate deposits to depressurization-induced gas production. *J. Pet. Sci. Eng.* **67**:1-12.
- Rutqvist, J. and Moridis, G. J. 2009. Numerical Studies on the Geomechanical Stability of Hydrate-Bearing Sediments. *SPE J.* **14** (2): 267-282. SPE-126129-PA. doi:10.2118/126129-PA.
- Sabet, M.A. 1991. *Well Test Analysis*. Contributions in Petroleum Geology and Engineering, Volume 8, Gulf Publishing Company, Houston, TX.
- Santamarina, J.C., Jang, J. 2009. Gas Production from Hydrate Bearing Sediments: Geomechanical Implications, *DOE-NETL Fire in the Ice* **9** (4): 18-22.
- Santamarina, J.C., Ruppel, C. 2009. Physical Properties of Hydrate-Bearing Sediments, SEG-Geophysics, in Gas Hydrates, part of the series Investigations in Geophysics, Editors M. Riedel, E. Willoughby, and S. Chopra.
- Satoh, T., Dallimore, S.R., Collett, T.S., Inoue, T., Hancock, S.H., Moridis, G., Weatherhill, B. 2005. Production-test planning for the JAPEX/JNOC/GSC et al. Mallik 5L-38 Gas Hydrate Production Research Well. Scientific Results from the Mallik 2002 Gas Hydrate Production Research Well Program, Mackenzie Delta, Northwest Territories, Canada, (ed.) S.R. Dallimore and T.S. Collett; Geological Survey of Canada, Bulletin **585**.
- Sava, D., and B. Hardage, 2009. Rock-physics models for gas-hydrate systems associated with unconsolidated marine sediments, in Collett, T., A. Johnson, C. Knapp and R. Boswell, eds., *Natural Gas Hydrates: Energy Resource and Associated Geologic Hazards*, The American Association of Petroleum Geologists Memoir **89**.
- Schicks, J. M., Ripmeester, J. A. *Angew* 2004. *Chem. Int. Ed.* **43**: 3310.
- Scholl, C., R. Mir, E.C. Willoughby, R.N. Edwards, 2008. Resolving resistive anomalies due to gas hydrate using electromagnetic imaging methods. Proceedings of the 6th International Conference on Gas Hydrates (ICGH 2008), Vancouver, British Columbia, CANADA, July 6-10, 2008.
- Schroeder, W. 1927. *Die Geschichte der Gashydrate*: 97.
- Schultheiss, P., Holland, M., Humphrey, G., 2009. Wireline coring and analysis under pressure: recent use and future developments of the HYACINTH system; *Scientific Drilling* **7**, 44-47.
- Seol, Y., Kneafsey, T.J., 2009. X-ray computed-tomography observations of water flow through anisotropic methane hydrate-bearing sand. *J. Pet. Sci. Eng.* **66** (3-4): 121-132.
- Shahbazi, A., Pooladi-Darvish, M., 2010, Behavior of Depressurization in Type III Hydrate Reservoirs, SPE-137047-PP presented at the 2010 CSUG/SPE Unconventional Resources and International Petroleum Conference to be held 19-21 October in Calgary, Alberta, Canada.
- Shedd, W., Frye, M., Boswell, R.M., Collett, T.S., McConnell, D., Jones, E., Shelander, D., Dai, J., Guerin, G., Cook, A., Mrozewski, S., Godfriaux, P.D., Dufrene, R., Hutchinson, D.R., Roy, R., 2009. Gulf of Mexico Gas Hydrate Joint Industry Project Leg II: Results from the Walker Ridge 313 Site, Paper OTC 20806, *Proceedings of the 2010 Offshore Technology Conference*, 3-6 May 2010, Houston, Texas, USA.
- Shelander, D., Dai, J., and G. Bunge, 2010. Predicting saturation of gas hydrates using pre-stack seismic data. *Marine Geophysical Researches*, doi:10.1007/s11001-010-9087-8.
- Sloan, E.D. 2000. *Hydrate Engineering*, Monograph 21, Society of Petroleum Engineers, Richardson, Texas.
- Sloan, E.D. 2004. *American Mineralogist* **89**: 1155.
- Sloan, E.D., Koh, C.A., 2008. *Clathrate hydrates of natural gases*, 3<sup>rd</sup> Edition: CRC Press, Taylor and Francis Group, Publishers, New York, New York.
- Sowers, T., 2006. Late quarternary atmospheric CH<sub>4</sub> isotope record suggest marine clathrates are stable. *Science* **311**: 838-840.
- Spangenberg, E., Besskow-Strauch, B., Luzi, M., Naumann, R., Schicks, J., Rydzy, M., 2008. The process of hydrate formation in clastic sediments and its impact on their physical properties. *Proc. Sixth International Conference on Gas Hydrates*, Vancouver, BC, Canada, July 5-10, 2008.
- Spangenberg, E., J. Kulenkampff, R. Naumann, J. Erzinger, 2005. Pore space hydrate formation in a glass bead sample from methane dissolved in water. *Geophys. Res. Lett.* **32**: L24301, doi:10.1029/2005GL024107.
- Spangenberg, E., Kulenkampff, J., 2005. Physical properties of gas hydrate-bearing sediments. *Proc. 5th International Conference on Gas Hydrates*, Trondheim, Norway.
- Spangenberg, E., Kulenkampff, J., 2006. Influence of methane hydrate content on electrical sediment properties. *Geophys. Res. Lett.* **33**: L24315.
- Staykova, D.K., Kuhs, W.F., Salamatin, A., Hansen, T. 2003. *J. Phys. Chem.* **107**: 10299.
- Stern, L.A., Kirby, S.H., Durham, W.B., 1996. Peculiarities of methane clathrate hydrate formation and solid-state deformation, including possible superheating of water ice. *Science* **273** (5283): 1843-1848.

- Stern, L.A., Kirby, S.H., Circone, S., Durham, W.B., 2004. Scanning electron microscopy investigations of laboratory-grown gas clathrate hydrates formed from melting ice, and comparison to natural hydrates. *American Mineralogist* **89** (8-9): 1162-1175.
- Sun, Y-F., Goldberg, D., 2005. Analysis of electromagnetic propagation tool response in gas-hydrate-bearing formations, in *Scientific Results from the Mallik 2002 Gas Hydrate Production Research Well Program, Mackenzie Delta, Northwest Territories, Canada*, (ed.) S.R. Dallimore and T.S. Collett; Geological Survey of Canada, Bulletin **585**.
- Tabatabaie, S.H., Pooladi-Darvish, M., 2009. Analytical Solution for Gas Production from Hydrate Reservoirs Underlain with Free Gas, *Journal of Natural Gas Science and Engineering*, **1**(1-2): 46-57
- Takayama, T., Nishi, M., Uchida, T., Akihisa, K., Sawamura, F., Ochiai, K., 2005. Gas hydrate saturation analysis using density and nuclear magnetic-resonance logs from the JAPEX/JNOC/GSC et al. Mallik 5L-38 gas hydrate production research well, in *Scientific Results from the Mallik 2002 Gas Hydrate Production Research Well Program, Mackenzie Delta, Northwest Territories, Canada*, (ed.) S.R. Dallimore and T.S. Collett; Geological Survey of Canada, Bulletin **585**.
- Thompson, L.G., Reynolds, A.C., 1997. Well Testing for Radially Heterogeneous Reservoirs Under Single and Multiphase Flow Conditions. *SPEFE* (1997) pp. 57 – 64.
- Tohidi, B., Anderson, R., Clennell, M.B., Burgass, R.W., Biderkab, A.B., 2001. Visual observation of gas-hydrate formation and dissociation in synthetic porous media by means of glass micromodels. *Geology* **29** (9): 867-870.
- Tohidi, B. et al., 2002. Application of high pressure glass micromodels to gas hydrates studies, *Proc. 4th International Conference on Gas Hydrates*, Yokohama.
- Tomutsa, L., Freifeld, B., Kneafsey, T.J., Stern, L.A., 2002. X-ray Computed Tomography Observation of Methane Hydrate Dissociation, *Proc. SPE Gas Technology Symposium*, Calgary, Alberta, Canada.
- Torres, M.E., Tréhu, A.M., Cespedes, N., Kastner, M., Wortmann, U.G., Kim, J.H., Long, P., Malinverno, A., Pohlman, J.W., Riedel, M., Collett, T.S., 2008. Methane hydrate formation in turbidite sediments of northern Cascadia, IODP Expedition 311. *Earth & Planetary Sci. Lett.* **271**: 170-180.
- Tréhu, A.M., Bohrmann, G., Rack, F.R., Torres, M.E., et al., 2004. Initial Reports, Drilling Gas Hydrates on Hydrate Ridge, Cascadia Continental Margin. *Proc. International Ocean Drilling Program* **204**: [http://www-odp.tamu.edu/publications/204\\_IR/front.htm](http://www-odp.tamu.edu/publications/204_IR/front.htm).
- Turner, D., Kumar, P. and Sloan, E., 2005. A New Technique for Hydrate Thermal Diffusivity Measurements. *Int. J. Thermophysics* **26** (6): 1681-1691.
- Uchida, T., Takeya, S., Chuvilin, E., Ohmura, R., Nagao, J., Yakushev, V., Istomin, V., Minagawa, H., Ebinuma, T., Narita, H., 2004. Decomposition of methane hydrates in sand, sandstone, clays, and glass beads, *Journal of Geophysical Research*, **109**, B05206, doi: 10.1029/2003JB002771
- Uchida, T., Ebinuma, T., Takeya, S., Nagao, J., Narita, H., 2002. Effects of pore size on dissociation temperatures and pressures of methane, carbon dioxide, and propane hydrates in porous media, *Journal of Physical Chemistry B*, **106**, 820-826.
- U.S. Department of Energy, 2010. Gas Hydrate Characterization in the Gulf of Mexico, [http://www.netl.doe.gov/technologies/oil-gas/FutureSupply/MethaneHydrates/projects/DOEProjects/MH\\_5668EMCharGOM.html](http://www.netl.doe.gov/technologies/oil-gas/FutureSupply/MethaneHydrates/projects/DOEProjects/MH_5668EMCharGOM.html)
- Valdes, J.R., Santamarina, J.C. 2006. Particle Clogging in Radial Flow: Microscale Mechanisms, *SPE J.* **11** (2): 193-198.
- van der Waals, J.H., Platteeuw, J.C. 1959. Clathrate Solutions, in *Adv. Chem. Phys.* **2**:1.
- Vysniauskas, A., and Bishnoi, P.R. 1983. A Kinetic Study of Methane Hydrate Formation. *Chem. Eng. Sci.* **38**: 1061-1072. Walsh, M.W., Koh, C.A., Sloan, E.D., Sum, A.K, Wu, D. T. 2009. Microsecond Simulations of Spontaneous Methane Hydrate Nucleation and Growth. *Science* **326**: 1095.
- Waite, W.F., deMartin, B.J., Kirby, S.H., Pinkston, J., Ruppel, C.D., 2002. Thermal conductivity measurements in porous mixtures of methane hydrate and quartz sand. *Geophys. Res. Lett.* **29** (24): 2229, doi:10.1029/2002GL015988.
- Waite, W.F., Winters, W.J., Mason, D.H., 2004. Methane hydrate formation in partially water-saturated Ottawa sand. *American Mineralogist* **89**: 1202–1207.
- Waite, W.F., Stern, L.A., Kirby, S.H., Winters, W.J., Mason, D.H., 2007. Simultaneous determination of thermal conductivity, thermal diffusivity and specific heat in sl methane hydrate. *Geophysical Journal International* **169** (2): 767-774.
- Waite, W.F., Kneafsey, T.J., Winters, W.J., Mason, D.H., 2008. Physical property changes in hydrate-bearing sediment due to depressurization and subsequent repressurization. *J. Geophys. Res.* **113**: B07102.
- Waite, W. F., Santamarina, J. C., Cortes, D. D., Dugan, B., Espinoza, D. N., Germaine, J., Jang, J., Jung, J. W.T., Kneafsey, T., Shin, H., Soga, K., Winters, W. J., Yun, T.-S. 2009. Physical properties of hydrate-bearing sediments, *Rev. Geophys.* **47**, RG4003, doi:10.1029/2008RG000279.
- Walsh, M., Hancock, S., Wilson, S., Patil, S., Moridis, G., Boswell, R., Collett, T., Koh, C., Sloan, D., 2009. Preliminary report on the economics of gas production from natural gas hydrates. *Journal of Energy Economics* **31**, 815-823.
- Watanabe, T., Shimizu, S., Asakawa, E., Kamei, R., Matsuoka, T. 2005. Preliminary assessment of the waveform inversion method for interpretation of cross-well seismic data from the thermal production test, JAPEX/JNOC/GSC et al. Mallik 5L-38 gas hydrate production research well; in *Scientific Results from the Mallik 2002 Gas Hydrate Production Research Well Program, Mackenzie Delta, Northwest Territories, Canada*, (ed.) S.R. Dallimore and T.S. Collett; Geological Survey of Canada, Bulletin **585**.
- Weitemeyer, K., Constable, S., 2009. Marine Electromagnetic Methods for Gas Hydrate Characterization, Gulf of Mexico, [http://www.netl.doe.gov/technologies/oil-gas/publications/Hydrates/2009Reports/NT05668\\_Preliminary\\_cruise\\_report.pdf](http://www.netl.doe.gov/technologies/oil-gas/publications/Hydrates/2009Reports/NT05668_Preliminary_cruise_report.pdf).
- Westbrook, G., Thatcher K., Rohling, E., Piotrowski, A., Palike, H., Osborne, A., Nisbet, E., et al. 2009. Escape of methane gas from the seabed along the West Spitsbergen continental margin. *Geophys. Res. Lett.* **36**: L15608.
- White, M., McGrail, B.P. 2008. Numerical Simulation of Methane Hydrate Production from Geologic Formations via Carbon Dioxide Injection, Paper OTC-19458-MS, Offshore Technology Conference, 5-8 May 2008, Houston, Texas, USA (doi: 10.4043/19458-MS).
- Wilder, J., Moridis, G., Wilson, S., Kurihara, M., White, M., Masuda, Y., Anderson, B., Collett, T., Hunter, R., Narita, H., Pooladi-Darvish, M., Rose, K., Boswell, R. 2008. An International Effort to Compare Gas Hydrate Reservoir Simulators. *Proc. 6th International Conference on Gas Hydrates*, July 6-10, 2008, Vancouver, BC.

- Winters, W.J., W.F. Waite, D.H. Mason, L.Y. Gilbert, I.A. Pecher, 2005. Grain size effects on acoustic and strength behavior of sediments containing natural- and laboratory-formed methane gas hydrate: *Proc. 5th International Conference on Gas Hydrates*, Trondheim, Norway.
- Winters, W.J., Waite, W.F., Mason, D.H., Gilbert, L.Y., Pecher, I.A. 2007. Methane gas hydrate effect on sediment acoustic and strength properties. *J. Pet. Sci. Eng.* **56**: 127-135.
- Worthington, P., 2010. Petrophysical evaluation of gas hydrate reservoirs. *Petroleum Geoscience* **16** 53-66
- Xu, W., Ruppel, C., 1999. Predicting the occurrence, distribution, and evolution of methane gas hydrate in porous marine sediments. *J. Geophys. Res.* **104**: 5081-5095.
- Yamamoto, K., Dallimore, S., 2008. Aurora-JOGMEC-NRCan Mallik 2006-2008 Gas Hydrate Research Project progress. *DOE-NETL Fire In the Ice*, Summer 2008: 1-5. <http://www.netl.doe.gov/technologies/oil-gas/publications/Hydrates/Newsletter/HMNewsSummer08.pdf#Page=1>
- Yamamoto, K., Nagakubo, S., 2009. Environmental risks of the gas hydrate field development in the Eastern Nankai Trough. American Geophysical Union Fall Meeting, San Francisco, 13-17 December 2009.
- Yang, S., Zhang, H., Wu, N., Su, X., Schultheiss, P., Holland, M., Zhang, G., Liang, J., Lu, J., Rose, K., 2008. High concentration hydrate in disseminated forms obtained in Shenhu area, North Slope of South China Sea. *Proc. 6th International Conference on Gas Hydrates* 6-10 July 2008, Vancouver, British Columbia, Canada.
- Yun, T.S., Francisca, F.M., Santamarina, J.C. Ruppel, C., 2005. Compressional and shear wave velocities in uncemented sediment containing gas hydrate. *Geophys. Res. Lett.* **32** (10): L10609.
- Yun, T.S., Narsilio, G.A., Santamarina, J.C., Ruppel, C., 2006. Instrumented pressure testing chamber for characterizing sediment cores recovered at in situ hydrostatic pressure. *Marine Geology* **229**: 285-293.
- Yun, T.S., Narsilio, G.A., Santamarina, J.C. 2006a. Geotechnical Characterization Of Gulf Of Mexico Sediments. *Mar. Pet. Geo.* **23**: 893-900.
- Yun, T.S., Narsilio, G.A., Santamarina, J.C., Ruppel, C. 2006b. Instrumented Pressure Testing Chamber for Characterizing Sediment Cores Recovered at In Situ Hydrostatic Pressure, *Marine Geology* **229**: 285-293.
- Yun, T.S., Santamarina, J.C. and Ruppel, C., 2007. Mechanical properties of sand, silt, and clay containing tetrahydrofuran hydrate. *J. Geophys. Res.* **112**: B04106.
- Yun, T. S. et al. 2010a. Hydrate bearing sediments from Krishna-Godavari Basin: Physical characterization, pressure core testing and scaled production monitoring, *Mar. Pet. Geo.*, in press.
- Yun T.S., Fratta D., Santamarina J.C. 2010b. Hydrate Bearing Sediments from the Krishna-Godavari Basin: Physical Characterization, Pressure Core Testing and Scaled Production Monitoring, submitted to *Mar. Pet. Geo.*
- Zatsepina, O., Hong, H., Pooladi-Darvish, M., 2008. Behaviour of Gas Production from Type III Hydrate Reservoirs. *Proc. 6th International Conference on Gas Hydrates*, July 6-10, 2008, Vancouver, BC.

### A Gulf of Mexico In-Place Gas Hydrate Resources

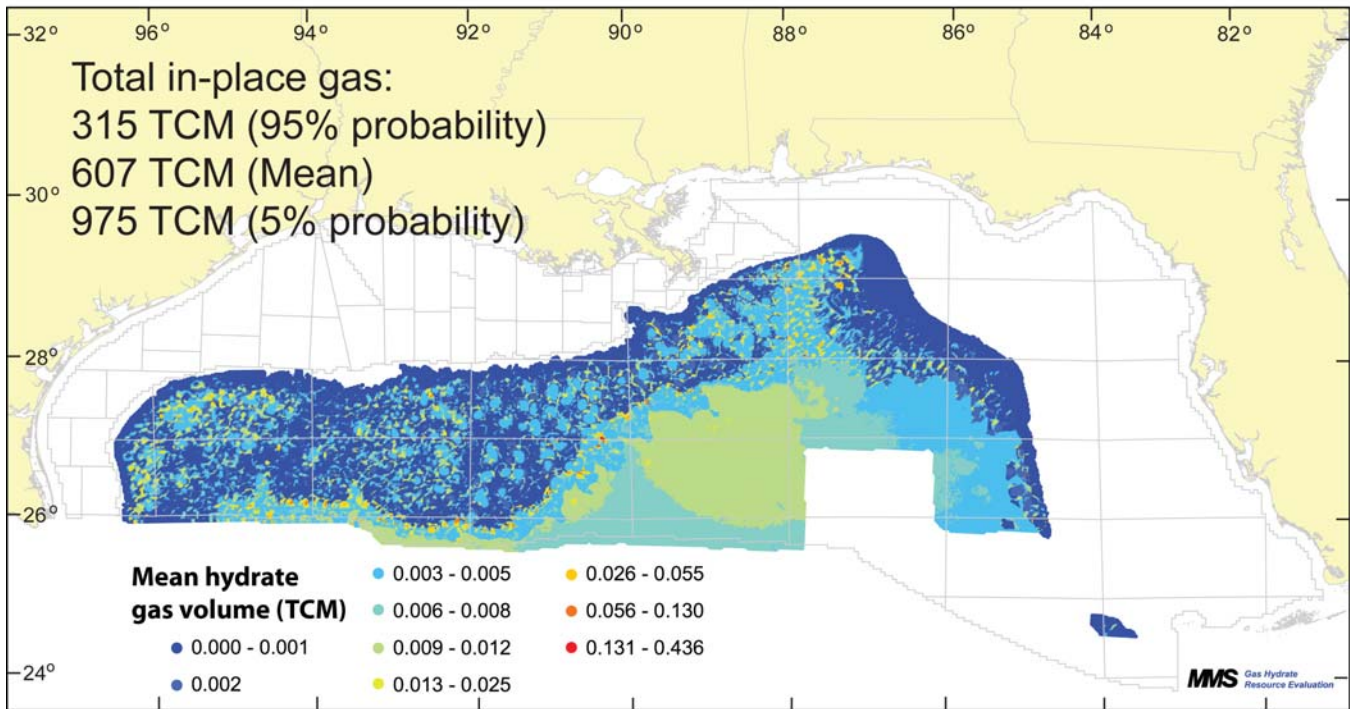

### B Gulf of Mexico In-Place Gas Hydrate Resources Sand Reservoirs Only

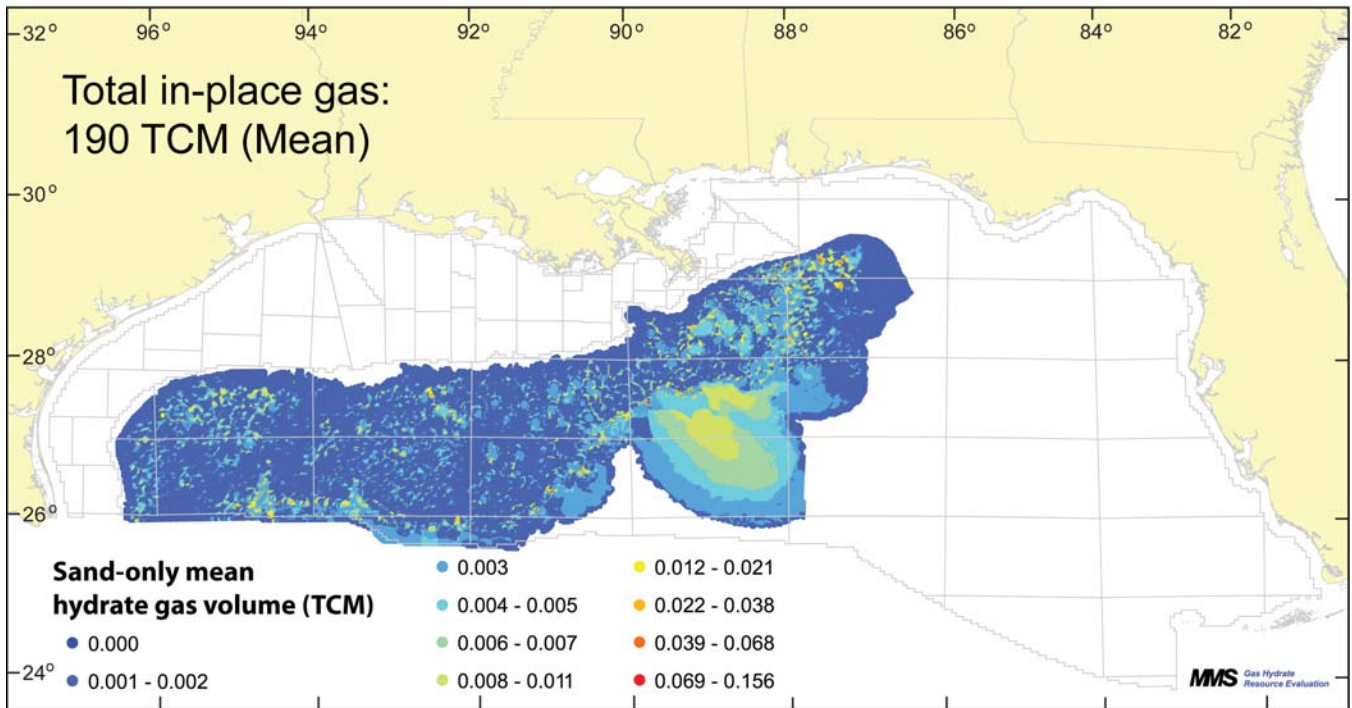

Figure 1 - Results of the MMS gas hydrate assessment in the Gulf of Mexico. (A) Map of the mean in-place volume of gas (at STP) within hydrates and (B) map of the mean in-place volume of gas (at STP) within hydrates only in sand reservoirs. TCM = trillion cubic meters; STP = standard temperature and pressure (1 atm and 20°C)



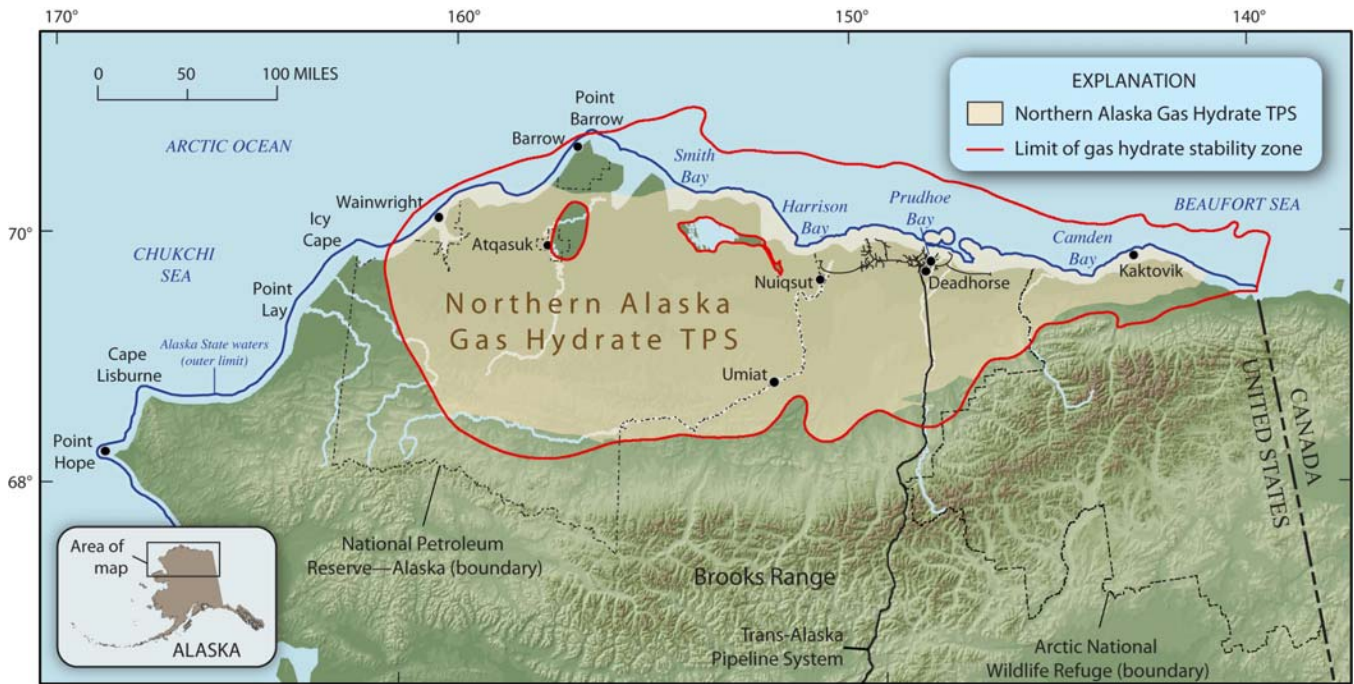

Figure 2 - Map showing the Northern Alaska Gas Hydrate Total Petroleum System (TPS) (shaded in tan), and the limit of gas hydrate stability zone in northern Alaska (Collett et al., 2008a).

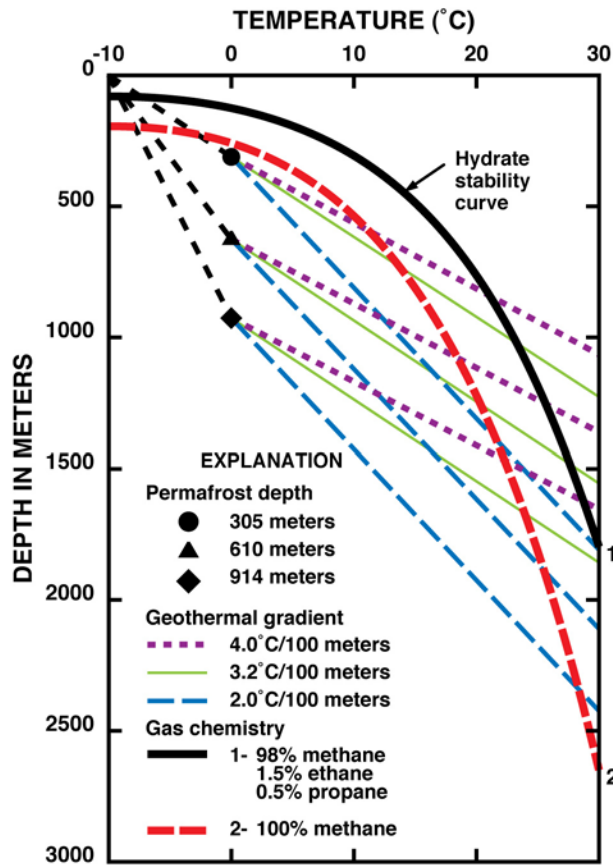

Figure 3 - Gas hydrate phase diagram showing the depth and temperature conditions suitable for the formation of gas hydrate under various conditions of permafrost depth, geothermal gradient, gas chemistry, and a pore-pressure gradient of 9.795 kPa/m (modified from Holder et al., 1987).

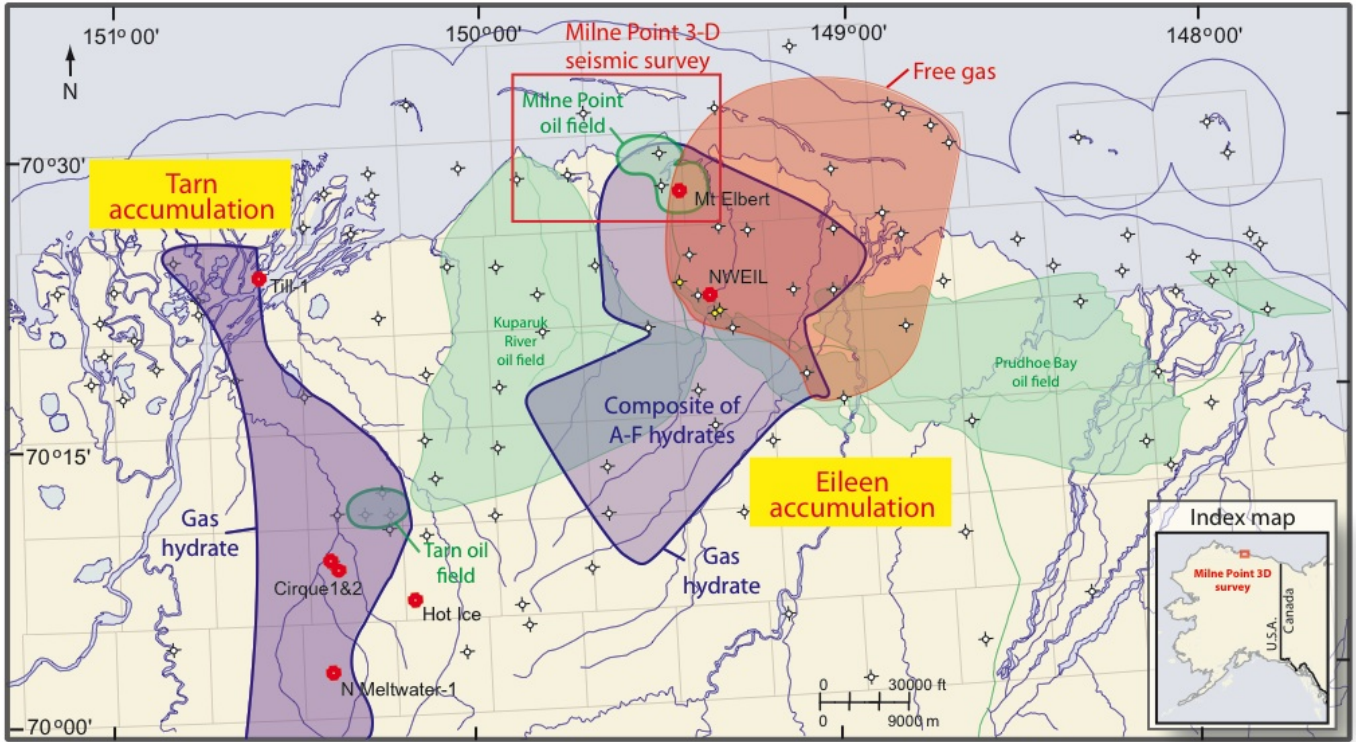

Figure 4 - Map of the Eileen and Tarn gas hydrate accumulations overlying portions of the Prudhoe Bay, Kuparuk River, and Milne Point oil fields (modified from Collett, 1993). Also shown are the locations of the Northwest Eileen State- 2 (NWEIL), Mount Elbert and Hot Ice gas hydrate research wells along with the outline of the Milne Point 3D seismic volume used to identify and map gas hydrate prospects.

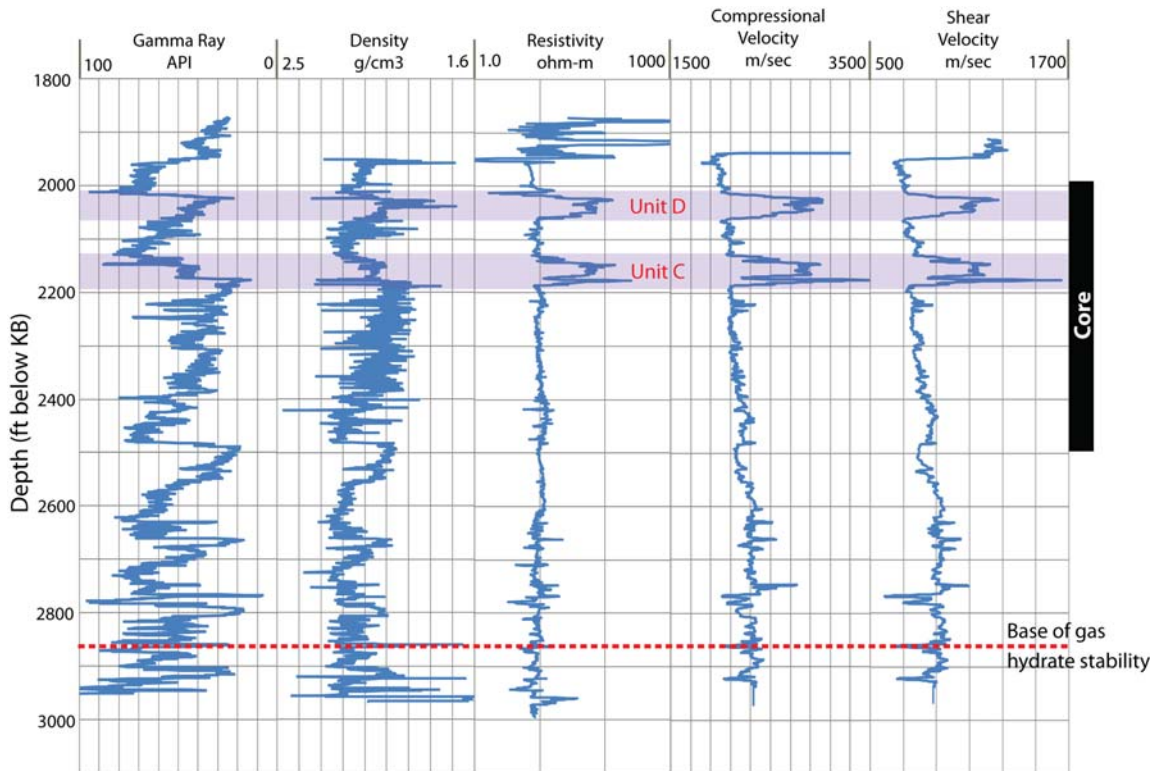

Figure 5 - Open-hole well logs from the cored section of the Mount Elbert gas hydrate stratigraphic test well (modified from Boswell et al., 2010a).



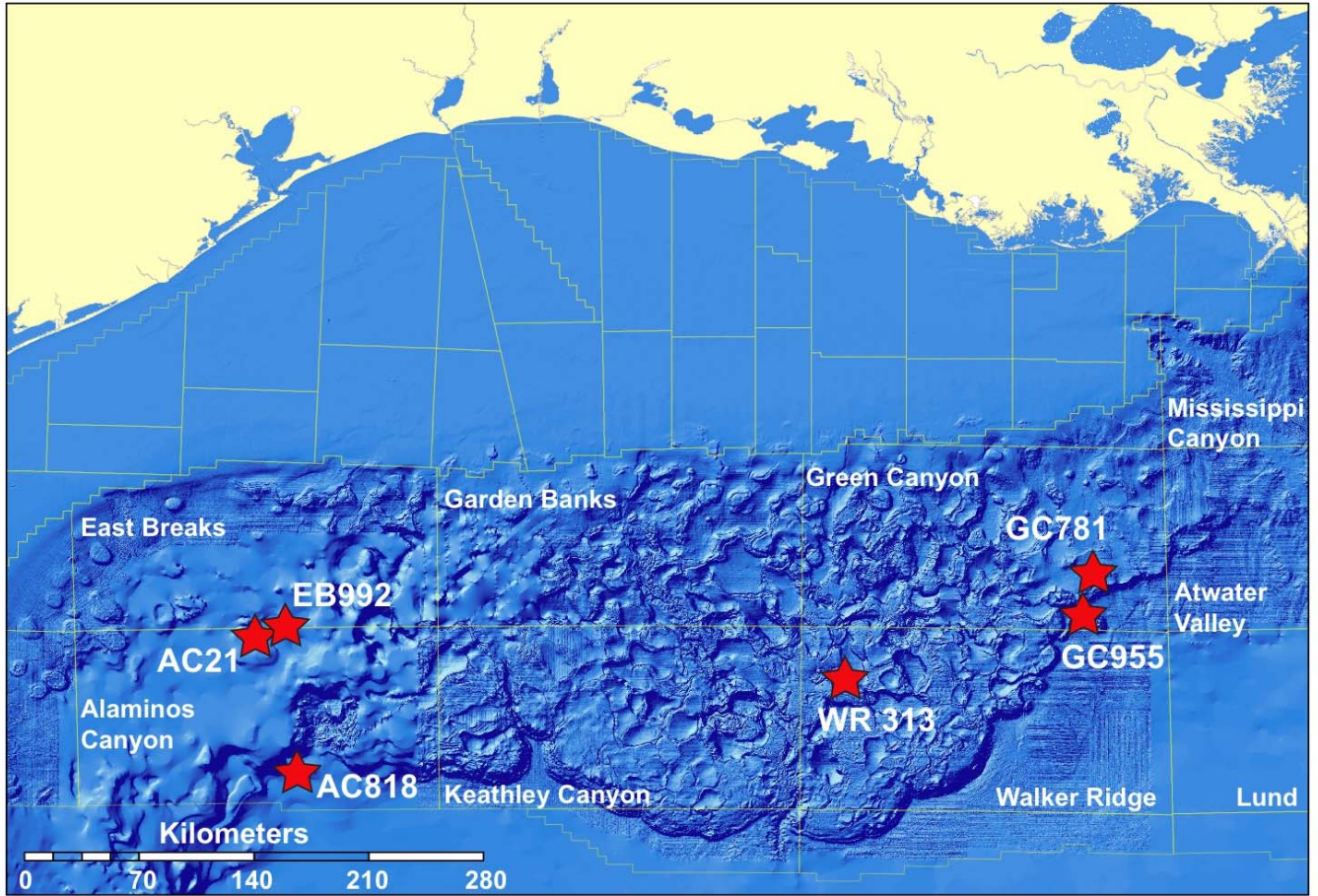

Figure 6 - Seafloor map of the Gulf of Mexico depicting the location of JIP Leg II drill sites (AC818, WR313, and GC955).



Figure 7 - Pressure core testing devices developed at Georgia Tech. (a) IPTC instrumented pressure testing chamber. (b) The IPTC- $\sigma'$  device permits the application of in-situ state of effective stress to determine effective stress dependent properties.

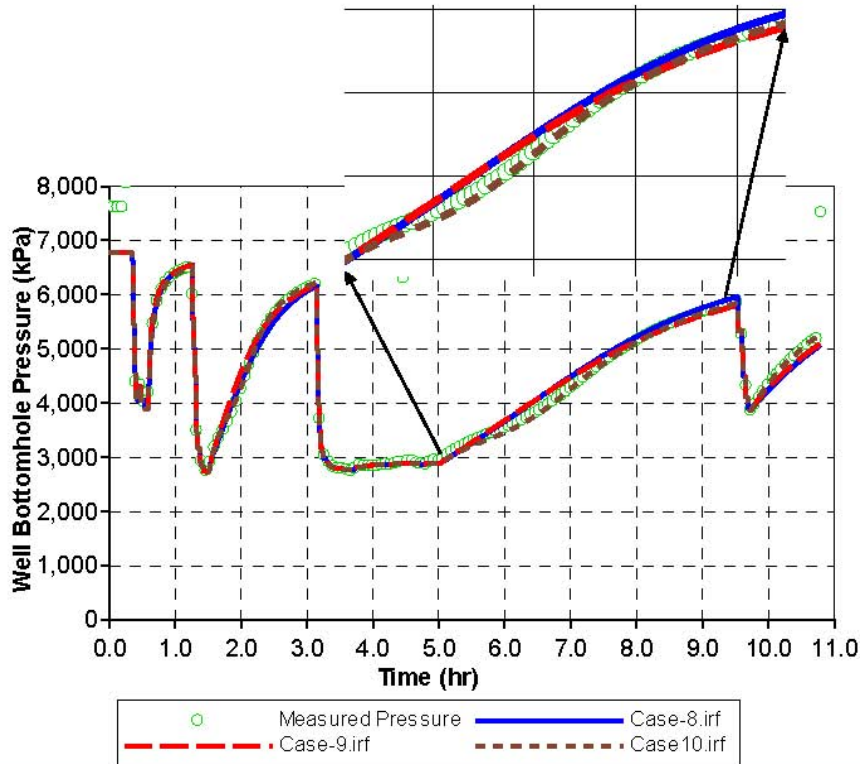

Figure 8 - Mt. Elbert MDT measured pressures and simulation results – Only Case 10 with slow formation reaction exhibits the inflection point seen in the measurements (Pooladi-Darvish and Hong 2010)

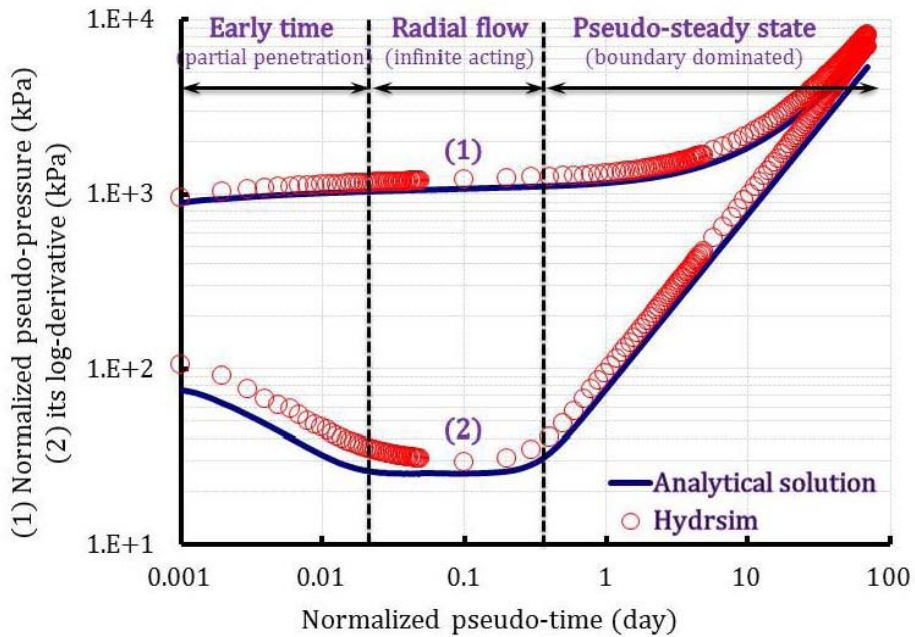

Figure 9 - Comparison between analytical and simulation results on a pressure and pressure derivative plot for a constant rate drawdown test (Gerami and Pooladi-Darvish 2009).



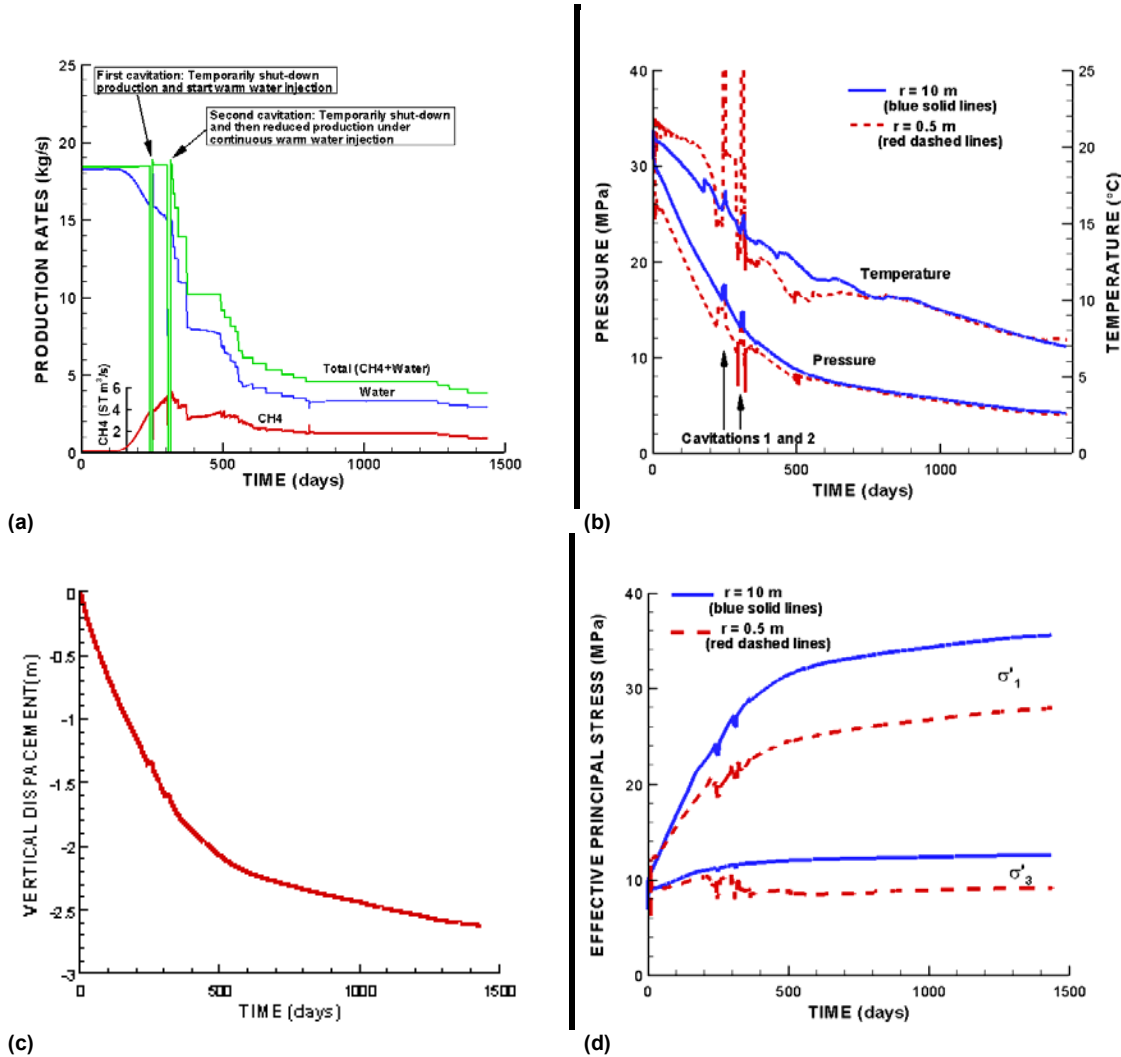

Figure 10 - Numerical simulation results of depressurization based gas production from a Class 2 oceanic hydrate deposit using a vertical production well: (a) Production rates (CH<sub>4</sub>, water and total rates), (b) pressure and temperature, (c) vertical subsidence, and (d) maximum and minimum principal stresses.

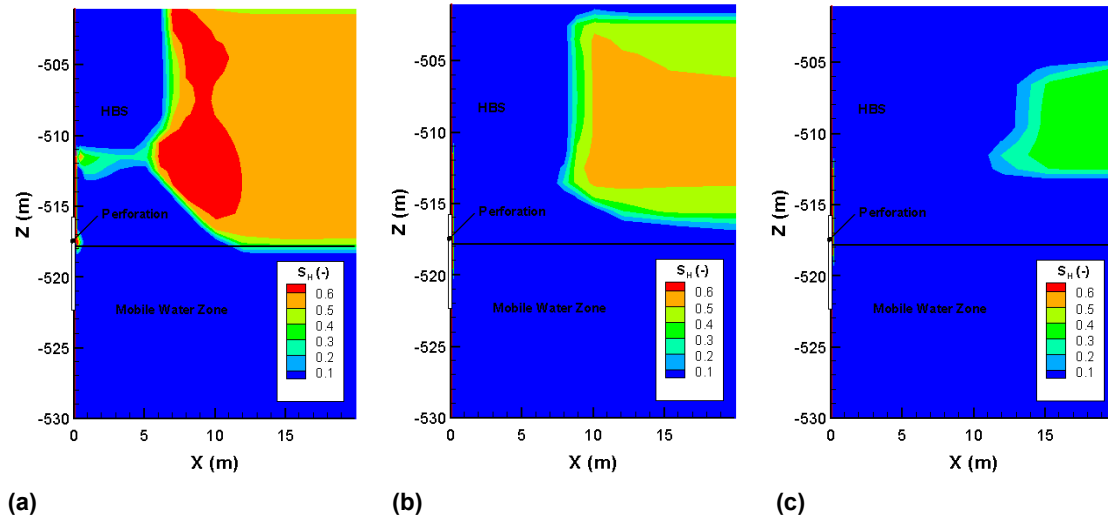

Figure 11 - Numerical simulation results of depressurization based gas production from a Class 2 oceanic hydrate deposit using a vertical production well: Hydrate saturation at (a) 1 year, (b) 2 years and (c) 4 years.

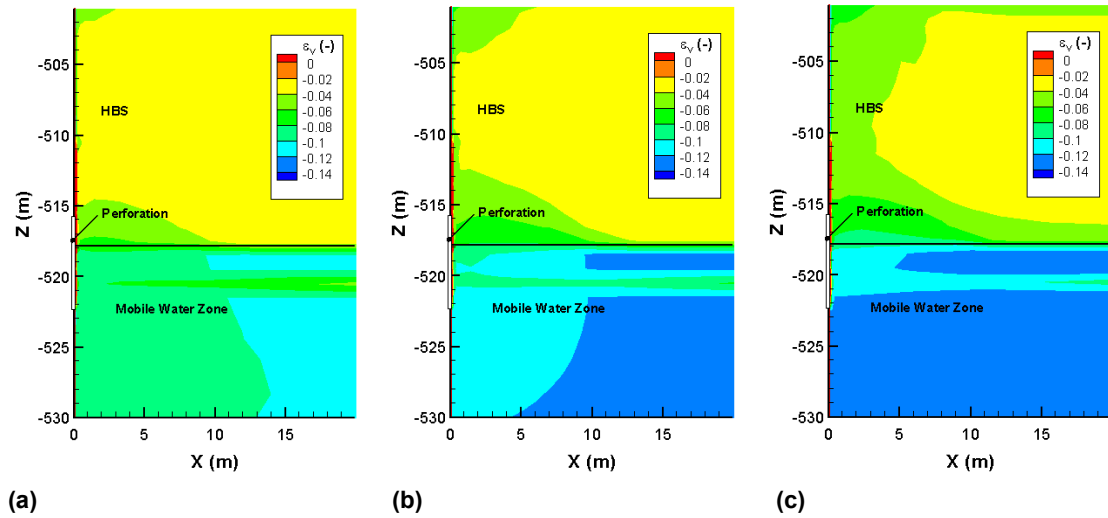

Figure 12 - Numerical simulation results of depressurization based gas production from a Class 2 oceanic hydrate deposit using a vertical production well: Volumetric strain at (a) 1 year, (b) 2 years and (c) 4 years.

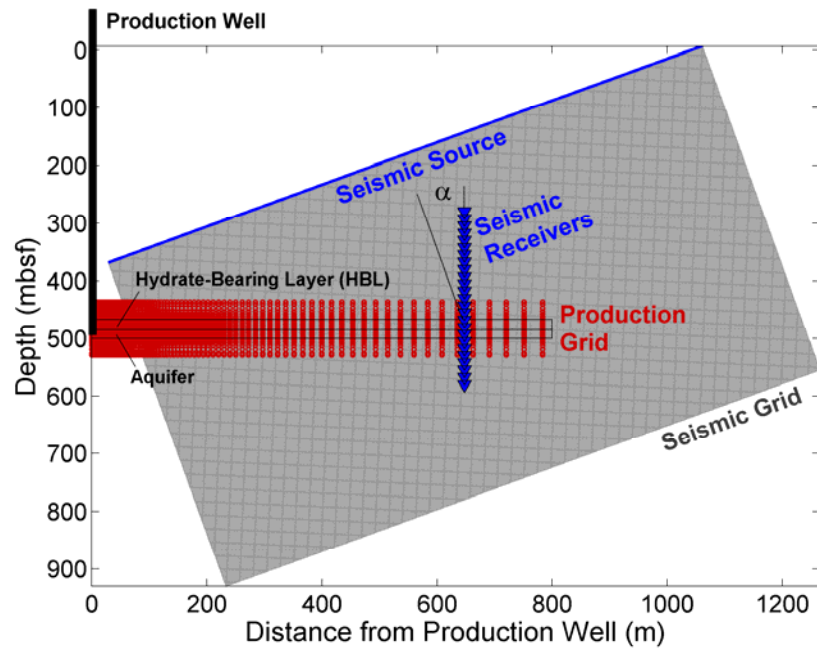

Figure 13 - Numerical grids used to simulate production of natural gas from the hydrate bearing-layer (red grid) and time-lapse seismic surveys (gray grid) in marine hydrate-bearing system. The angle  $\alpha$  between the production grid and the seismic grid determines the angle of the incoming seismic wave relative to the HBL. For the example shown in the Figure 2,  $\alpha = 20^\circ$ , with the seismic grid rotated accordingly (from Kowalsky et al., in press).

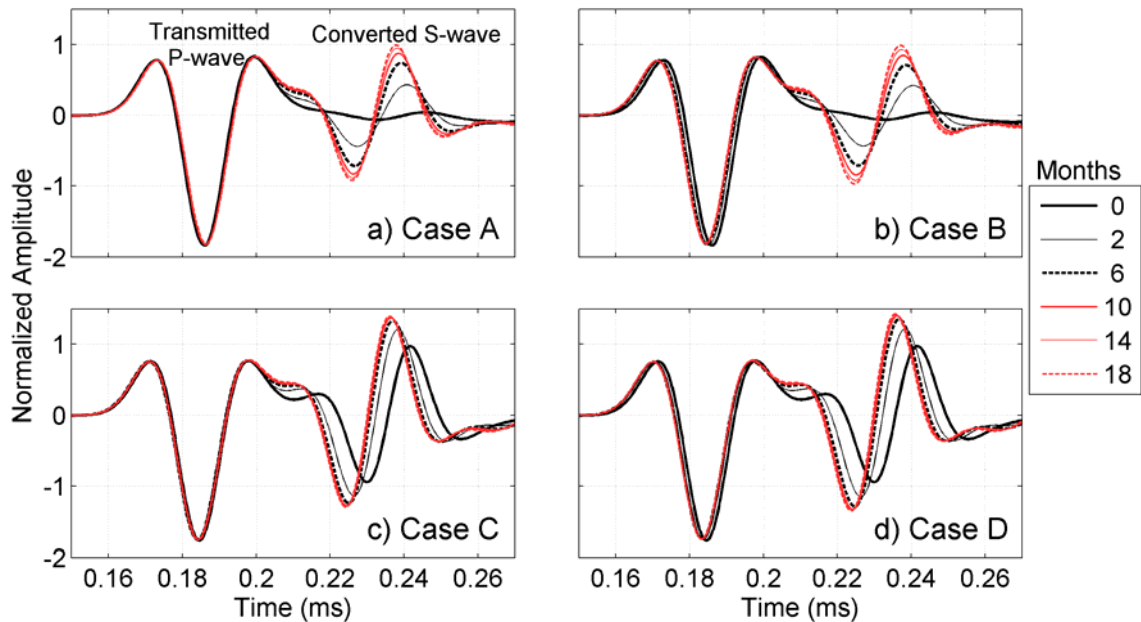

Figure 14 - Seismic signal recorded approximately 100 m below the bottom of a hydrate-bearing layer in a simulated VSP survey. The horizontal component of the waveform is shown with the transmitted P-wave and converted S-wave arrivals. Waveforms are shown at six survey times (0, 2, 6, 10, 14, and 18 months after the start of production) for four different rock physics models (a-d) (from Kowalsky et al., in press).

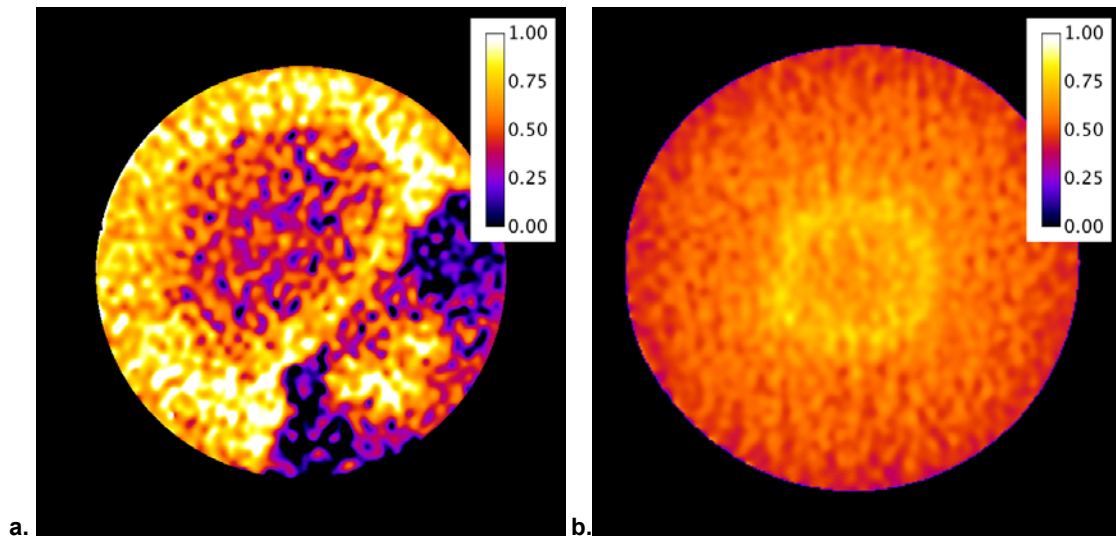

Figure 15 - Methane hydrate saturation in porous media using the excess gas method. Left: Nonuniform hydrate saturation in a disk-shaped sample cross section computed from CT data. Right: Less heterogeneous methane hydrate saturation in a laboratory-formed sample containing sand and silt (Kneafsey, unpublished data).

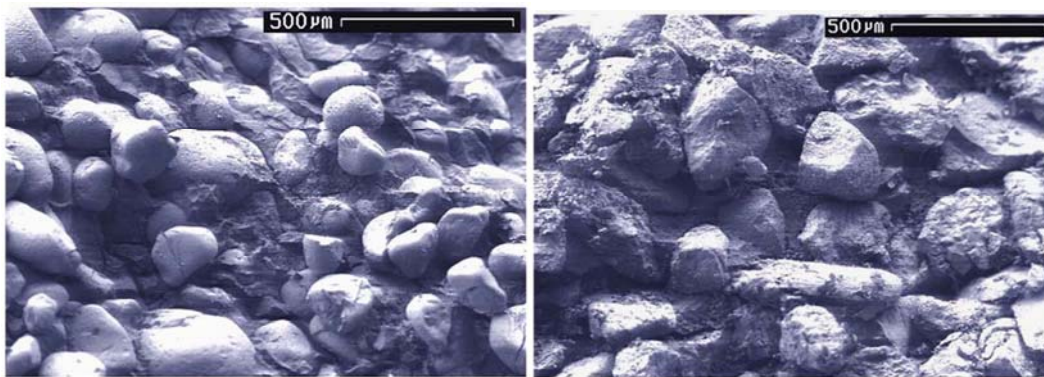

Figure 16 - Hydrate (dark) surrounding quartz (light) grains. left - Laboratory-synthesized quartz sand/hydrate, right - Natural quartz sand/hydrate sample from Mallik. From Stern et al. (2004).

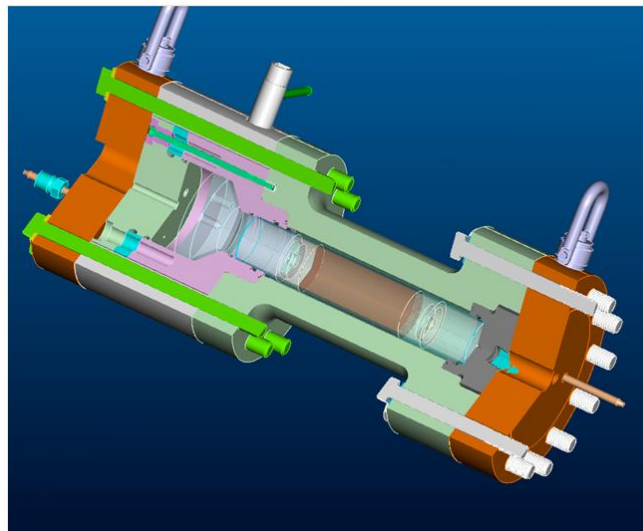

Figure 17 - Cutaway drawing of the x-ray transparent geomechanical/geophysical test cell showing the sample (brown), end platens (adjacent to sample ends), and conical piston (transparent, left side) used to apply the axial load.

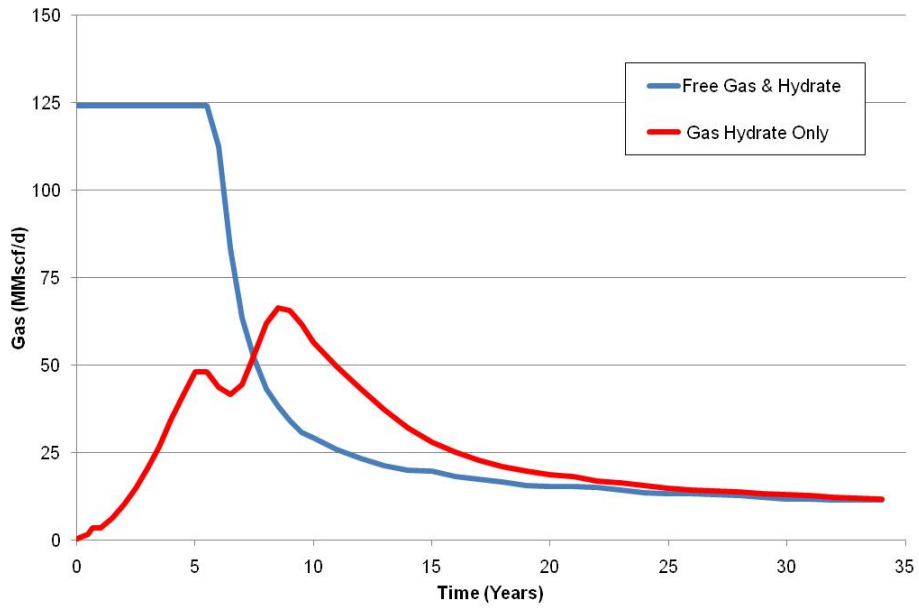

Figure 18 - Field Gas Production Rate (MMscf/d) for Onshore Gas Hydrate Study

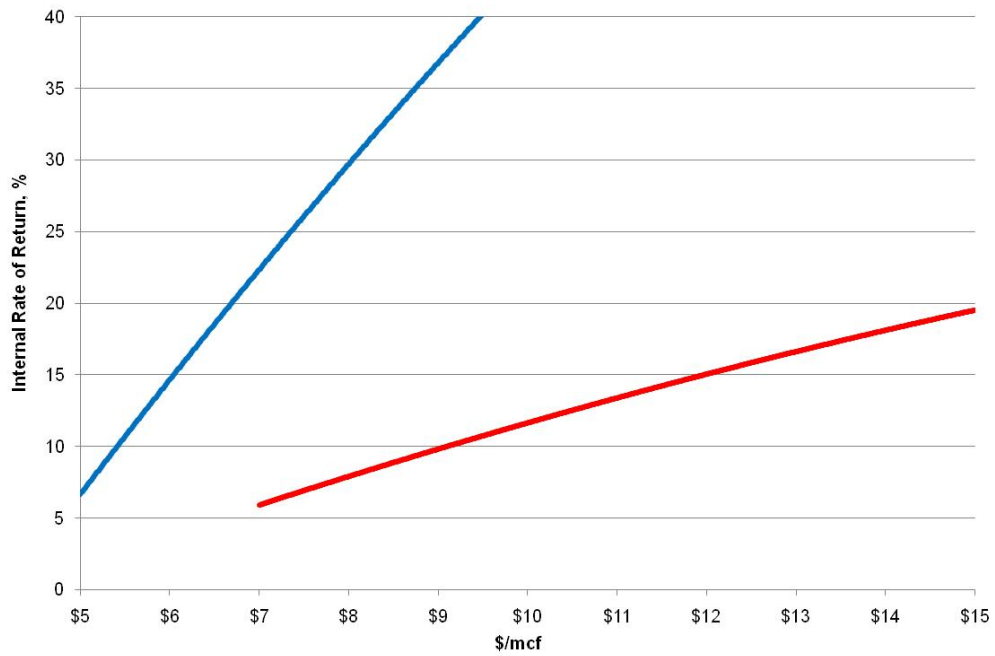

Figure 19 - Internal Rate of Return as a Function of Gas Price (\$/mcf) for Onshore Gas Hydrate Study

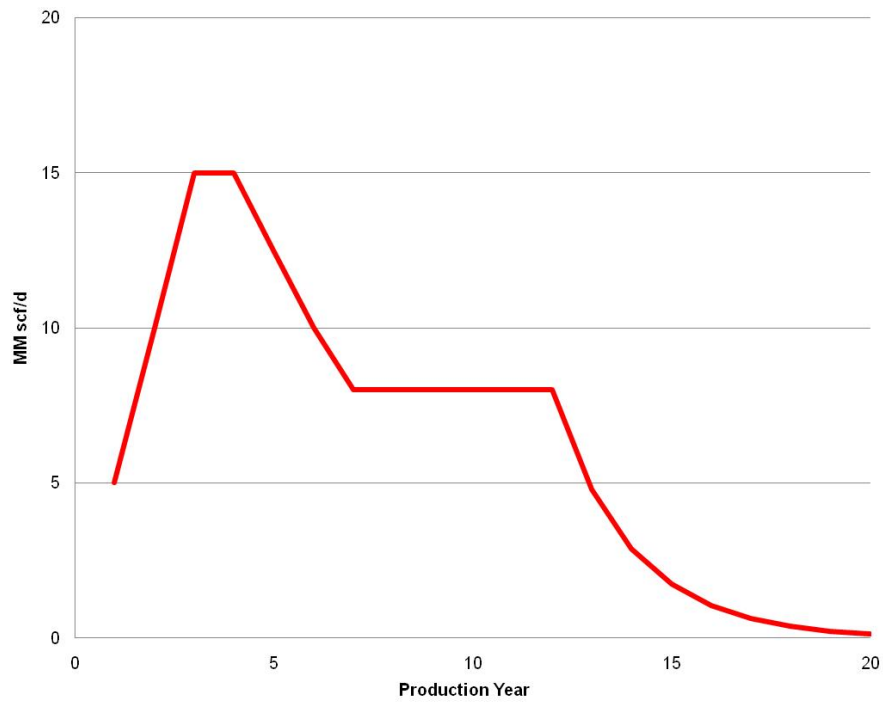

Figure 20 - Single Well Gas Production rate (MMscf/d) for Offshore Gas Hydrate Study

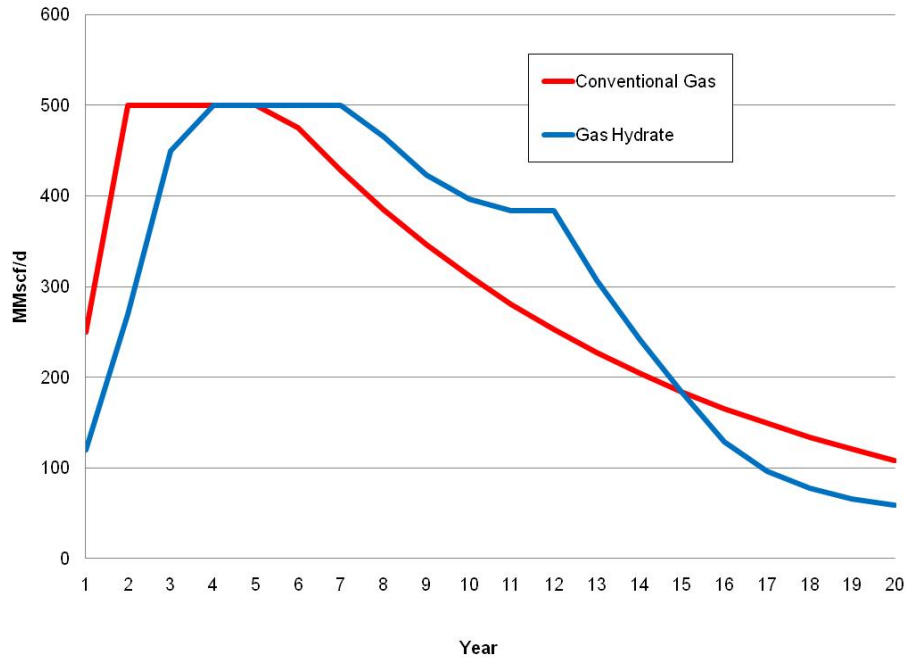

Figure 21 - Field Gas Production rate (MMscf/d) for Offshore Gas Hydrate Study

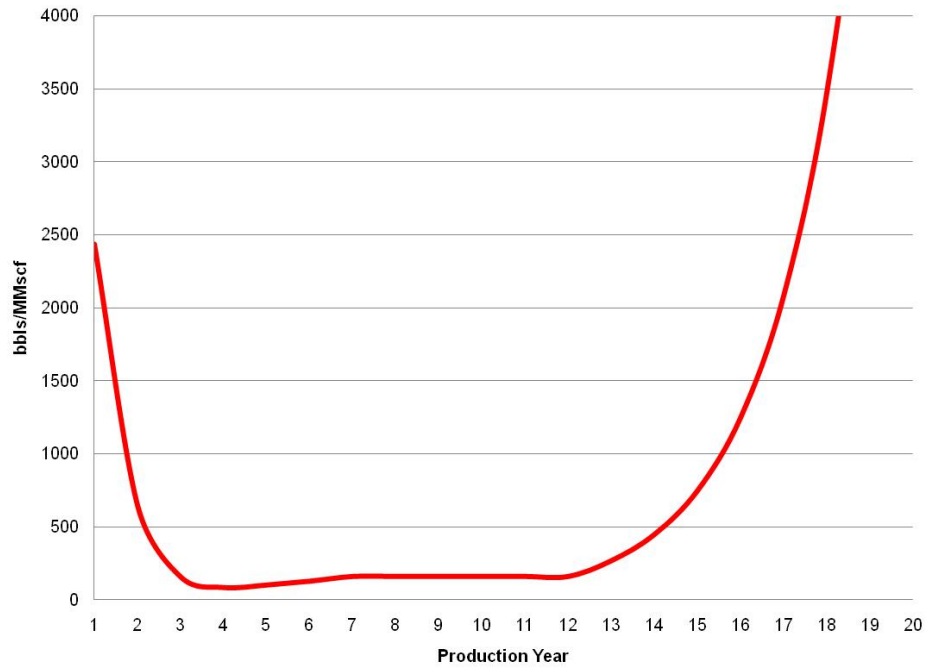

Figure 22 - Gas Water Ratio (bbls/MMscf) for Offshore Gas Hydrate Study

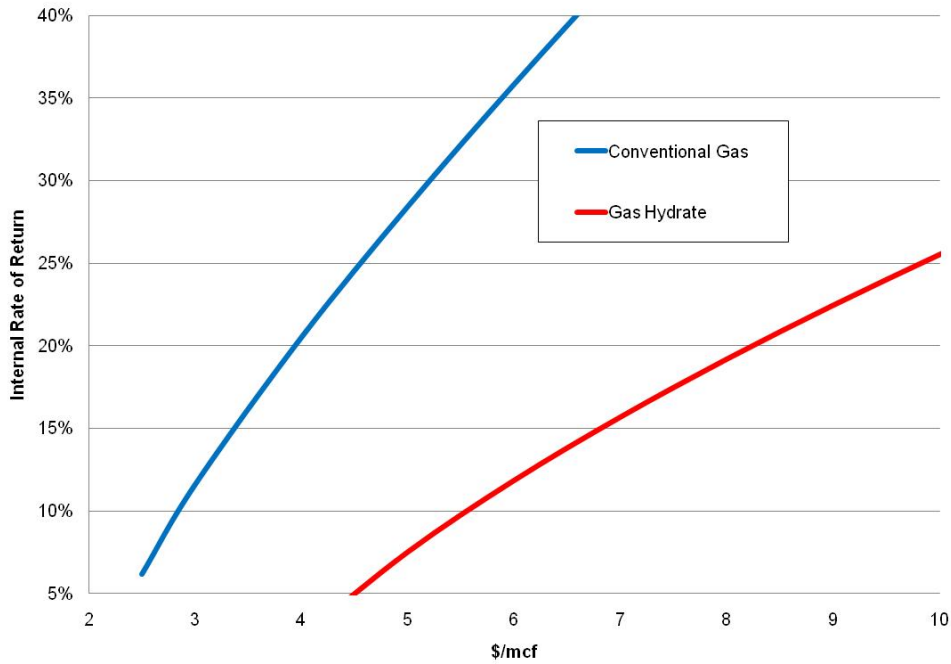

Figure 23 - Internal Rate of Return as a Function of Gas Price (\$/Mscf) for Offshore Gas Hydrate Study

## **LEGAL DISCLAIMER**

This document was prepared as an account of work sponsored by the United States Government. While this document is believed to contain correct information, neither the United States Government nor any agency thereof, nor The Regents of the University of California, nor any of their employees, makes any warranty, express or implied, or assumes any legal responsibility for the accuracy, completeness, or usefulness of any information, apparatus, product, or process disclosed, or represents that its use would not infringe privately owned rights. Reference herein to any specific commercial product, process, or service by its trade name, trademark, manufacturer, or otherwise, does not necessarily constitute or imply its endorsement, recommendation, or favoring by the United States Government or any agency thereof, or The Regents of the University of California. The views and opinions of authors expressed herein do not necessarily state or reflect those of the United States Government or any agency thereof or The Regents of the University of California.