



VOLUME 17.

BUILDING AMERICA BEST PRACTICES SERIES



Energy Renovations

Insulation

A Guide for Contractors to Share
with Homeowners

PREPARED BY

Pacific Northwest National Laboratory
& Oak Ridge National Laboratory

May 2012



BUILDING AMERICA BEST PRACTICES SERIES

Energy Renovations

Volume 17: Insulation

A Guide for Contractors to Share with Homeowners

Prepared by

Pacific Northwest National Laboratory

Michael C. Baechler, Project Manager

K. T. Adams, M. G. Hefty, and T. L. Gilbride

and

Oak Ridge National Laboratory

Pat M. Love

May 2012

Prepared for the

U.S. Department of Energy Building America Program

PNNL-20972

Pacific Northwest National Laboratory

Richland, Washington 99352

Contract DE-AC05-76RLO 1830

This report was prepared as an account of work sponsored by an agency of the United States Government. Neither the United States Government nor any agency thereof, nor Battelle Memorial Institute, nor any of their employees, makes any warranty, express or implied, or assumes any legal liability or responsibility for the accuracy, completeness, or usefulness of any information, apparatus, product, or process disclosed, or represents that its use would not infringe privately owned rights. Reference herein to any specific commercial product, process, or service by trade name, trademark, manufacturer, or otherwise does not necessarily constitute or imply its endorsement, recommendation, or favoring by the United States Government or any agency thereof, or Battelle Memorial Institute. The views and opinions of authors expressed herein do not necessarily state or reflect those of the United States Government or any agency thereof.



Preface

The U.S. Department of Energy recognizes the enormous potential that exists for improving the energy efficiency, safety, and comfort of existing American homes. This series of Energy Renovation Guides describes approaches for homeowners and builders working on existing homes.

This guide will help contractors and homeowners identify ways to make their homes more comfortable, more energy efficient, and healthier to live in. It also identifies the steps to take, with the help of a qualified home performance contractor, to increase their home's insulation, ensure healthy levels of ventilation, and prevent moisture problems. Contractors can use this document to explain the value of these insulation measures to their customers. The references in this document provide further explanation of insulation techniques and technologies.

Heating and cooling account for 50% to 70% of the energy used in the average American home (DOE 2008b). Heat gain or loss due to inadequate insulation is a leading cause of energy waste in most homes. Studies show that proper insulation and air sealing techniques can typically achieve whole-house energy savings of 10% to 20% over pre-retrofit energy usage (EPA 2011b). In older homes and homes with little or no insulation, savings may be much higher.

These recommendations for improving insulation are based on the results of research and demonstration projects conducted by the U.S. Department of Energy's Building America and Home Performance with ENERGY STAR, sponsored by the U.S. Environmental Protection Agency and DOE. Home Performance with ENERGY STAR offers a comprehensive, whole-house approach to improving the energy efficiency and comfort of existing homes and requires a test-in/test-out process. DOE's Building America has worked with some of the nation's leading building scientists and more than 600 production builders on more than 42,100 new homes. Building America's research applies building science to the goal of achieving efficient, comfortable, healthy, and durable homes.



You can learn more about Building America and download additional copies of this document and others, including climate guides, best practices guides, research reports, and case studies, at www.buildingamerica.gov.

To see the current list of Building America research teams, go to www.eere.energy.gov/buildings/building_america/research_teams.html.

Contents

Preface	i
1.0 Introduction	1
1.1 How to Use this Guide	2
1.2 The Home Performance Energy Checkup	2
1.3 When to Get a Home Energy Checkup	3
2.0 Adding Insulation during Remodeling Projects – When, Where, and How Much	5
2.1 When and Where to Add Insulation	5
2.2 How Much Insulation to Add	7
2.3 The Bottom Line: Is Adding Insulation Worth the Cost?	11
3.0 Types of Insulation	13
3.1 Insulation Table Summary Tables	13
3.2 Vapor Retarders	18
4.0 Insulation—Safety and Health Issues	19
4.1 Health and Safety Steps: Do These Before You Insulate	19
4.2 Insulation Products: Health and Safety Concerns	22
5.0 How to Add Insulation	27
5.1 Insulating an Attic	29
5.1.1 Preparing to Insulate an Attic	29
5.1.2 Insulating a Vented Attic	32
5.1.3 Insulating Unvented Attics	37
5.2 Insulating Flat Roofs and Vaulted Ceilings	43
5.3 Insulating Exterior Walls	44
5.3.1 Stud-Framed Walls: When to Insulate	44
5.3.2 Stud-Framed Walls: Adding Interior Cavity Insulation	47
5.3.3 Stud-Framed Walls: Adding Exterior Insulation	50
5.3.4 Masonry Walls: When and Where to Insulate	52
5.3.5 Masonry Walls: Adding Exterior Insulation	53
5.3.6 Masonry Walls: Adding Interior Insulation	53
5.4 Insulating a Crawlspace	55
5.4.1 Why Vents Should be Closed in Humid Climate Zones	57
5.4.2 Insulation for a Closed Crawlspace	57
5.4.3 How to Seal and Insulate a Crawlspace	58
5.4.4 Insulating a Crawlspace in Dry and Marine Climate Zones	61

5.5 Insulating Basements	62
5.5.1 Moisture Control and Air Sealing	63
5.5.2 Choosing the Best Approach for Insulating your Basement	63
5.5.3 Preparing to Insulate your Basement	67
5.5.4 Installing Insulation on the Interior of Basement Walls	69
5.5.5 Installing Insulation on the Exterior of Basement Walls	70
5.5.6 Installing Insulation on the Basement Ceiling	71
5.5.7 Maintaining a Dry, Problem-free Basement	72
5.6 Insulating Concrete Floors	72
5.6.1 Insulating the Surface of a Concrete Floor	73
5.6.3 Insulating the Perimeter of a Slab	75
5.7 Insulating Ducts	77
References	81
Photo Credits	85

Appendix A – How Insulation Works: Understanding Heat Flow and Air Pressure	A.1
--	-----

Appendix B – Air Leakage, Moisture, and Ventilation: Why You Need a “Whole-House” Approach ..	B.1
B.1. Air Leakage	B.1
B.2. Moisture	B.3
B.3. Ventilation	B.3
B.4 Vapor Retarders	B.5

Appendix C – Building America Energy Performance Briefs for Improving Existing Homes	C.1
Air Sealing a Flue or Chimney Shaft	C.3
Improving Recessed Lighting	C.5
Air Sealing Duct Boots and Duct Chases	C.7
Preventing Ice Dams	C.9
Insulating Attic Kneewalls	C.11
Installing a Radiant Barrier in the Attic	C.13
Insulating and Air Sealing Cantilevered Floors	C.15
Air Sealing a Porch Wall	C.17
Insulating and Air Sealing Tubs	C.19
Air Sealing and Insulating Fireplace Enclosures	C.21
Insulating Pipes	C.23
Insulating Hot Water Heaters	C.25
Keeping Wind-Blown Rain Out of Soffits	C.27
Installing Sidewall and Kick-out Diverter Flashing on Homes with Rigid Foam Insulation Sheathing	C.29
Installing Sidewall and Kick-out Diverter Flashing on Homes with Housewrap over OSB or Plywood Sheathing	C.31

1.0 Introduction



Your home may not be well insulated. The insulation may be too thin, uneven, or missing altogether. Cracks, leaks, or vents in walls, floors, ceilings, or roofs may allow air to flow through your insulation, reducing its effectiveness. Adding insulation and sealing air leaks can make your home more comfortable, increase its value, and cut your utility bills.

This guide provides descriptions of the many insulation options available to homeowners, along with guidance on where, when, and how to install insulation throughout your house. The guide was developed by the U.S. Department of Energy's Building America program, which works with building scientists and construction experts to identify effective, research-backed measures to save energy and improve the comfort of your home.

This country has more than 128 million homes. Eighty percent of them were built prior to 1980, and the vast majority of these are poorly insulated. State adoption of residential energy codes didn't become common until 1983, when the Model Energy Code for residential and commercial buildings was first issued (Halverson et al. 2009). Pre-1980 homes are responsible for a majority of the residential energy use in the country (DOE 2009d), and many homes built after 1980 can also have inadequate insulation.

Inadequate or improperly installed insulation and poor air sealing make your home less energy efficient and less durable. Large swings in indoor temperature and humidity can result, causing wood to swell and shrink and paint to crack and peel. Your heating and air conditioning equipment undergoes more wear and tear because it has to operate more frequently and for longer periods.

Attic insulation. In the attic below, batts were installed in a sloppy fashion and some of them have been moved out of place, leaving big gaps in the insulation layer (Photo Source: PNNL).



Insulation and Air Sealing:

Air sealing and insulation work together to improve comfort and performance.

You may think that insulation is the first step in making your home comfortable and energy efficient. However, money spent on insulation can be wasted if you don't first seal the holes and gaps in your ceilings, walls, and foundation.

Insulation works by trapping a layer of warm, still air around your house. If air is allowed to flow through the insulation, from cracks or holes in the walls, the warm air is no longer trapped and the insulation is "robbed" of its R-value.

Without air sealing, the air you pay to heat and cool escapes from your house. Incoming air can bring in moisture, dust, and air pollutants. A contractor trained in whole-house building science understands that air leaks should be identified and sealed before any insulation is added. For more information on how insulation and air sealing work, see Appendix A at the back of this guide.

For detailed information on air sealing an existing home, see the U.S. Department of Energy's Air Sealing Guide at http://apps1.eere.energy.gov/buildings/publications/pdfs/building_america/ba_airsealing_report.pdf



An effective insulation project will put money back in your pocket. As energy prices continue to climb, the dollars you save will only increase. At the same time, the additional insulation will improve your comfort, increase your home's value, and benefit the environment by reducing carbon dioxide emissions.

1.1 How to Use this Guide

FOR HOMEOWNERS. This guide will help you make sure that the best research-supported practices are used to improve your home's insulation as part of an energy upgrade. The guide describes types of insulation and their R-values (the common measurement of insulation effectiveness), and explains insulation approaches for various parts of your house. It also provides valuable information about safety and health issues related to insulation.

FOR CONTRACTORS. Share this guide with your customers so they can understand the building science process you will follow to improve insulation as part of an energy upgrade. This guide explains the research-backed, whole-house approach to improving comfort, durability, and energy efficiency. It explains the connections between insulation, air sealing, ventilation, and moisture, and clarifies the options of projects and materials.

1.2 The Home Performance Energy Checkup

Insulation upgrades can improve the energy efficiency, durability, and comfort of your home, and can save money in the long term. However, it is important to recognize that each component of a house interacts with the rest of the house.

To ensure health and safety, your insulation options should be considered within a whole-house, systems-based approach advocated by the U.S. Department of Energy's Building America program and building scientists across the country. This whole-house approach, which is based on years of research in thousands of real homes, takes into account how one change in a home's insulation can affect the energy efficiency, comfort, durability, and safety of the whole house.

To implement this whole-house approach and to confirm real energy-use improvements, Building America recommends that insulation upgrades start with a home performance energy checkup (also known as an assessment or audit). This whole-house checkup

should be conducted by a contractor who is trained and certified in building science principles, such as those described in the following:

- DOE *Guidelines for Home Energy Upgrade Professionals*, www.eere.energy.gov/wip/retrofit_guidelines.html
- U.S. Environmental Protection Agency’s *Healthy Indoor Environment Protocols for Home Energy Upgrades*, www.epa.gov/iaq/homes/retrofits.html
- Home Performance with ENERGY STAR programs
- Building Performance Institute (BPI) standards
- State weatherization programs
- Accredited college program recommendations.

The checkup consists of three steps: testing in, conducting the work, and testing out. In the test-in step, the contractor interviews homeowners about any concerns they have about their home, such as comfort complaints or high utility bills; conducts safety tests and tests for air leakage in the ducts and whole house; and visually inspects for insulation levels and signs of mold or moisture problems. The contractor uses energy software to analyze the results and gives this report to the homeowner, along with a prioritized list of recommendations. The homeowner works with the energy performance contractor or another qualified contractor to determine a scope of work and have the work completed. In the test-out step, the completed work is evaluated with safety tests and visual inspections. For more information on what you can learn from a home performance energy assessment and why it is a good idea to have one, visit the websites of Home Performance with ENERGY STAR or the Building Performance Institute.

It is impossible to overstress the importance of finding a contractor trained in building science. Don’t skimp on time or effort here. Your contractor will become your “expert” and will ultimately control the quality of the job, so find out as much as possible about all the candidates. Costs can vary widely, so consider the quality of the proposed work and materials.

1.3 When to Get a Home Energy Checkup

“My house is not comfortable.” Many homeowners decide to do a home energy assessment because their home is too cold, too hot, or too drafty. An assessment will identify solutions, such as air sealing, replacing HVAC equipment, and adding insulation.



As part of the home performance energy checkup, your certified contractor will use a blower door test to measure whole-house air leakage and determine places where insulation and air sealing are inadequate (Photo Source: PNNL).

See Appendix A and B for more building science basics.

How to find a certified energy contractor

An easy way to find a certified energy contractor is through a national or regional retrofit program. One such program is Home Performance with ENERGY STAR, a national program from the U.S. Environmental Protection Agency and the U.S. Department of Energy that is applied at the state level. Go to www.energystar.gov and click on the link for Home Performance with ENERGY STAR. Next, click on the “locations” link for certified contractors in your state. You can also find local contractors who understand the whole-house approach through the Building Performance Institute, www.bpi.org, and the Residential Energy Services Network, www.resnet.us.

Do Not Proceed with Energy Upgrades if...

If your home has any of the conditions listed below, the problems must be corrected before adding insulation or proceeding with any home energy upgrades:

- moldy or rotted attic rafters or floor joists
- visible mold or mildew growth on surfaces anywhere in the house including the basement or crawlspace
- damaged or wet insulation
- wood rot
- insect infestation
- leaking pipes
- liquid water entering the home or crawlspace from improper irrigation practices, ground slope, rain runoff, or high groundwater tables
- kitchen, bathroom, or clothes dryer vents that exhaust moist air directly into the attic space instead of outdoors
- an unvented kerosene heater or gas fireplace
- a history of ice dams in the winter, which can indicate serious air leaks
- elevated levels of carbon monoxide, radon, or other indoor air pollutants
- knob-and-tube wiring (pre-1930), which can be a fire hazard when in contact with insulation
- vermiculite insulation in the attic or walls, which may contain asbestos. Asbestos is a serious health hazard. See Section 4.2.

Another motivator is decreasing energy bills. On average, home energy check-ups can identify ways to reduce energy bills by 20% or more. You should obtain a home energy checkup when the roof needs to be replaced, when

you want to make an addition or finish a basement or attic, or when you are planning major remodeling. Because work already has to be done and equipment fixed or purchased, this is an opportune time to get an energy checkup for your home.

Without a professional energy checkup, you may miss existing health and safety problems, you may end up with poor indoor air quality, and your project may create dangerous problems with combustion appliances.

Profile

New Insulation Increases Durability



Poor insulation contributed to decay in hundreds of homes built on Native American reservations in the 1970s. The Yakama Nation Housing Authority teamed with Building America to design a retrofit package that included stripping out old sheetrock, insulation, roofing, windows, plumbing, appliances, and heating equipment; laying new R-19 batts in the attic; covering the batts and new mastic-sealed ducts with 12 inches of blown cellulose; covering exterior walls with rigid foam and new siding; installing R-30 fiberglass batt under-floor insulation; weather stripping attic and crawlspace hatches; and installing new heat pumps, windows, roofs, and roof ventilation. Together these changes cut energy use by 47% and greatly improved durability and comfort. (Source: DOE 2009b)

2.0 Adding Insulation during Remodeling Projects—When, Where, and How Much



Remodeling and renovation projects can create ideal opportunities for adding insulation. This chapter provides specific suggestions on when to add insulation, where to add insulation around your home, and how much insulation to add.

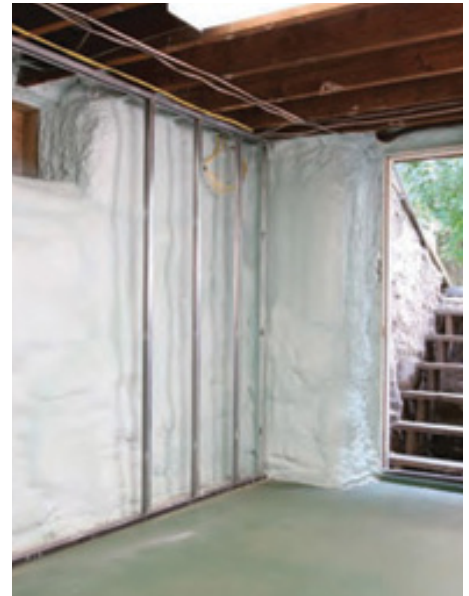
2.1 When and Where to Add Insulation

Adding insulation to **attics** is usually easy and cost-effective at any time, but replacing a roof creates an ideal time to do it. You will have access to all parts of the attic for air sealing as well as insulation. You will also have the opportunity to use highly effective exterior rigid insulation.

You can add insulation to an unfinished **basement** at any time, as long as you carefully address moisture and ventilation issues. Moisture and ventilation strategies must also be part of a project to turn a basement or attic into living space. You can insulate the **crawlspace** at any time, adding underfloor insulation if you live in a dry or marine climate. If you live in a humid climate, Building America scientists recommend converting it to an unvented crawlspace and insulating its walls.

Replacing siding or drywall creates an ideal time to add insulation to **walls**. Adding insulation to walls at other times requires drilling holes into the wall and blowing in insulation, known as “drill and fill.” The repaired holes may be unsightly. However, remodeling can create opportunities to drill and fill without leaving evidence. New kitchen cabinets, for example, will hide the filled holes, as will new crown molding or chair railing.

Insulating a basement. A basement can be turned into living space by air sealing and insulating the walls. In this basement, spray foam insulation does both jobs (Photo Source: Building Science Corporation).





Missing air barrier. This photo shows a bathtub and the batt insulation in the wall behind it. This tub was installed without a proper air barrier, such as cement fiber board or rigid foam, to cover the batt insulation. As a result, air can flow through the wall cavity, robbing the insulation of its heat-retaining properties and making the tub feel cold. If you are replacing your tub or shower, make sure your contractor insulates the wall behind it and covers it with sheathing to prevent drafts and convective air currents (Photo Source: PNNL).

When replacing a **bathroom** tub or shower against an exterior wall, you should take the opportunity to air seal and add insulation to the wall. (See Appendix C for project details.) When you drill new holes to install plumbing or wiring, you may wish to use the holes for blowing in insulation before patching them. Even if you don't choose to increase the wall insulation, make sure you air seal the holes around the pipes and wiring to avoid air leaks.

Replacing or repairing a **chimney** or adding insulation in an attic may be an opportunity to perform air sealing and to insulate gaps around the chimney. (See Appendix C for project details.) Replacing a **fireplace** may be another time to insulate. In some homes, fireplaces were built with no insulation in the wall behind them; this is the chance to add it. (See Appendix C.)

You may not wish to wait until remodeling or renovation creates an ideal opportunity to insulate. You can make energy and air-sealing improvements in your home any time you have problems with comfort, air quality, moisture, mold, or excessive energy bills, or if you want to take advantage of tax rebates and incentives. The figure below shows key places where properly installed and adequate insulation can solve energy, comfort, and durability problems.

Examples of Where to Insulate

- In unfinished attic spaces, insulate between and over the floor joists to seal off living spaces below.
 - attic access door
- In finished attic rooms with or without dormer, insulate...
 - between the studs of "knee" walls;
 - between the studs and rafters of exterior walls and roof;
 - ceilings with cold spaces above;
 - and extend insulation into joist space to reduce air flows.
- Insulate all exterior walls, including...
 - walls between living spaces and unheated garages, shed roof, or storage areas;
 - foundation walls above ground level;
 - foundation walls in heated basements, full wall either interior or exterior.
- Insulate floors above cold spaces, such as vented crawl spaces and unheated garages. Also insulate...
 - any portion of the floor in a room that is cantilevered beyond the exterior wall below;
 - slab floors built directly on the ground;
 - as an alternative to floor insulation, foundation walls of unvented crawl spaces;
 - extend insulation into joist space to reduce air flows.
- Insulate band joists.
- Caulk and seal around all windows and doors.

ORNL 96-5415R2/abh

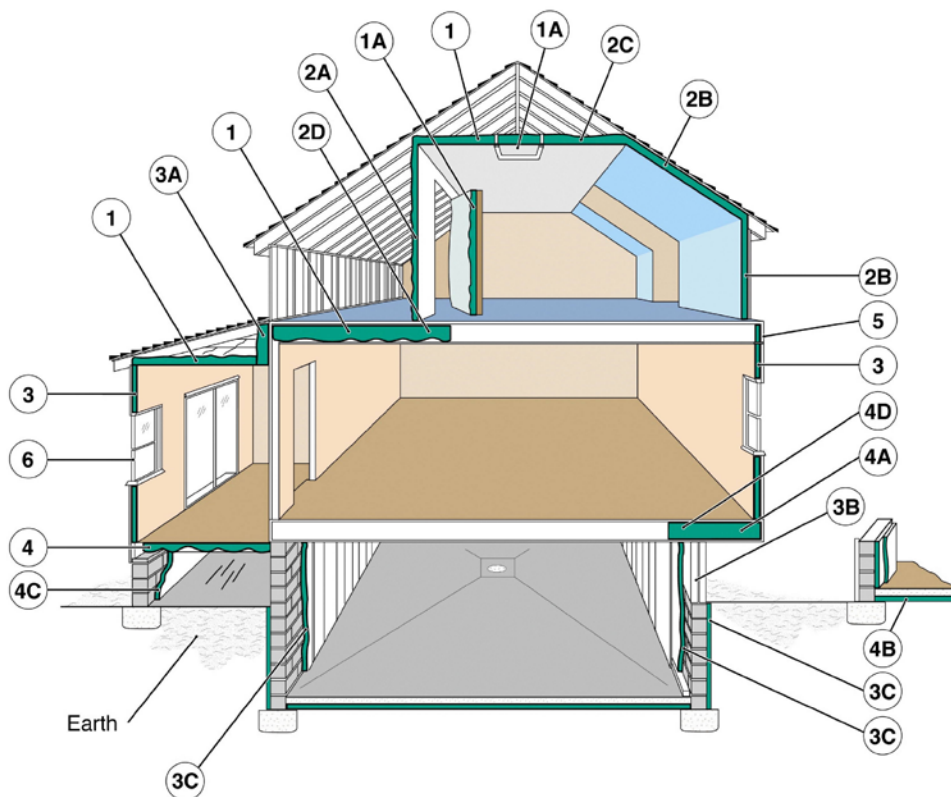


Figure 2.1. Building America research has identified key areas where insulation can improve a home's comfort, durability, and energy efficiency. (Source: 2008b)

2.2 How Much Insulation to Add

How much insulation you'll need to add depends on how much insulation you currently have. As part of a home performance energy assessment, your contractor will:

- **Identify** the amount of insulation you have, what shape it's in, and what your energy-efficiency goals are
- **Recommend** measures to address comfort, health, safety, air quality, and moisture issues
- **Identify** the most cost-effective improvements.

Before you call a home performance contractor, you may wish to do some preliminary estimates yourself. DOE and EPA offer three online tools that can help you assess your insulation needs.

THE ZIP-CODE INSULATION PROGRAM, developed by DOE's Oak Ridge National Laboratory, can be found at www.ornl.gov/~roofs/zip/ziphome.html. It will tell you the most cost-effective insulation levels for your house, based on its location. You enter your zip code, information about your house, and current costs of the fuel you use. The site will show you DOE's recommended R-values for your climate. The ZIP-Code site's cost-effectiveness recommendations are based on average local energy prices, regional average insulation costs, equipment efficiencies, climate factors, and energy savings for both the heating and cooling seasons.

HOME ENERGY SAVER (<http://homeenergysaver.lbl.gov/consumer/>) computes a home's energy use based on models and data developed at DOE's Lawrence Berkeley National Laboratory. Users can enter detailed information about their energy sources, appliances, heating and air conditioning equipment, location of duct work, and current insulation levels. On the basis of these, the site generates a list of energy-saving upgrade recommendations. It also projects the reduction in carbon emissions.

AIR SEAL AND INSULATE WITH ENERGY STAR provides links to information at www.energystar.gov/index.cfm?c=home_sealing.hm_improvement_sealing. ENERGY STAR is a program of the U.S. Environmental Protection Agency and DOE.



Depth of insulation. When installing loose-fill insulation in an attic, your contractor should staple rulers in several places to ensure the insulation is deep enough and has been spread evenly. These rulers are also useful for measuring changes over time as insulation settles (Photo Source: PNNL).

What is R-Value?

Insulation is rated in terms of its resistance to heat flow, called its R-value. The R-value of insulation depends on the type of material, its thickness, and its density. The higher the R-value, the more effective the insulation. R-values are usually given per inch of building material. Since R-values are cumulative, using thicker material or a combination of materials provides more resistance to heat flow.

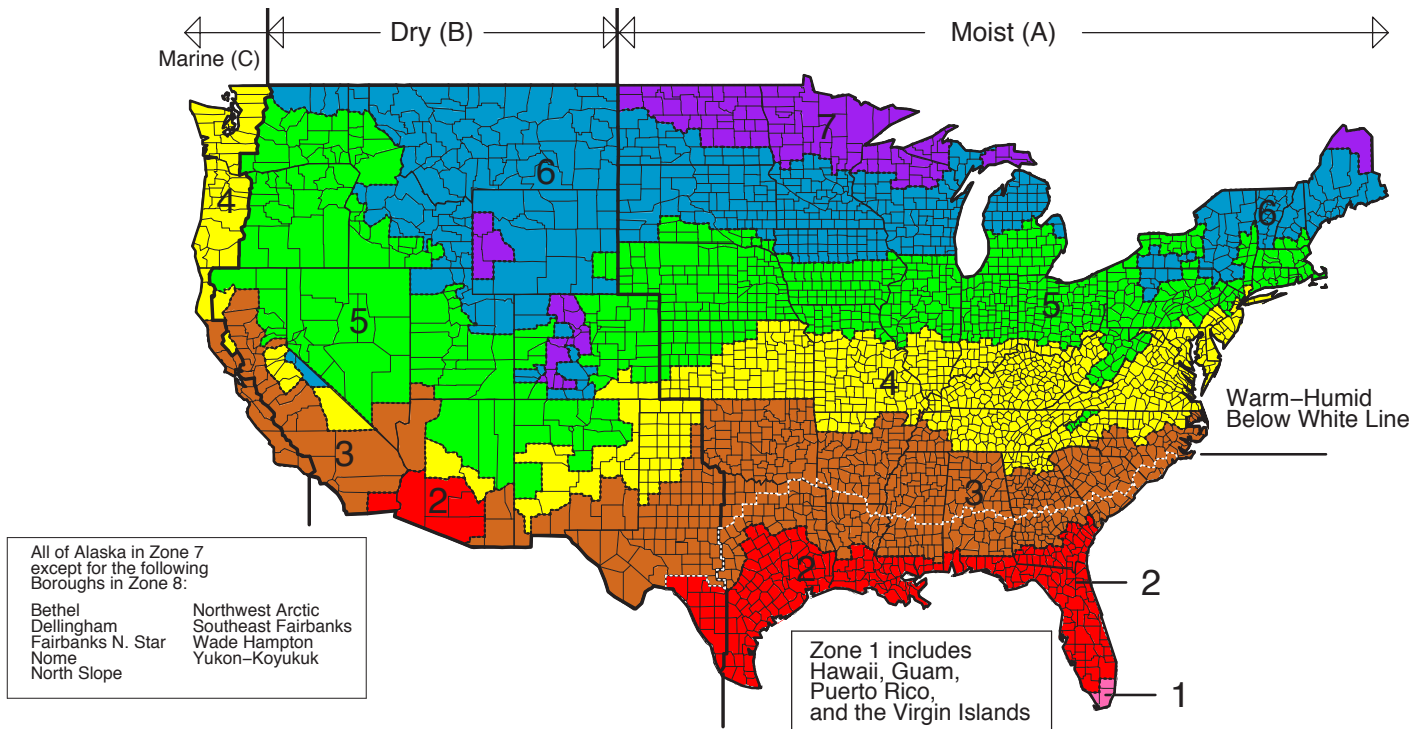


Figure 2.2. IECC Climate Regions. Designated by the International Energy Conservation Code (IECC) (Figure Source: 2009 IECC; Briggs et al. 2003).

Energy Codes

Check with your local building department to see which codes apply to your remodeling job. When you add insulation to an existing house, you typically do not have to meet code-required R values for new homes, unless you're building an addition or finishing a basement or attic. However, the latest codes are good goals to aim for; reaching them will improve your home's energy efficiency and increase its resale value. The requirements vary by climate zone, based on the International Energy Conservation Code (IECC)-designated climate zones shown on the map below. The insulation requirements for both the 2009 and 2012 IECC are shown in Table 2.1.

Each state sets its own building energy efficiency requirements. Many states base their codes on the IECC. The code is updated every three years. Many states have adopted the 2009 IECC. The 2012 IECC was published in June 2011 and is now available for adoption. For information about each states energy code, see the DOE site www.energycodes.gov/states/maps/residentialStatus.stm.

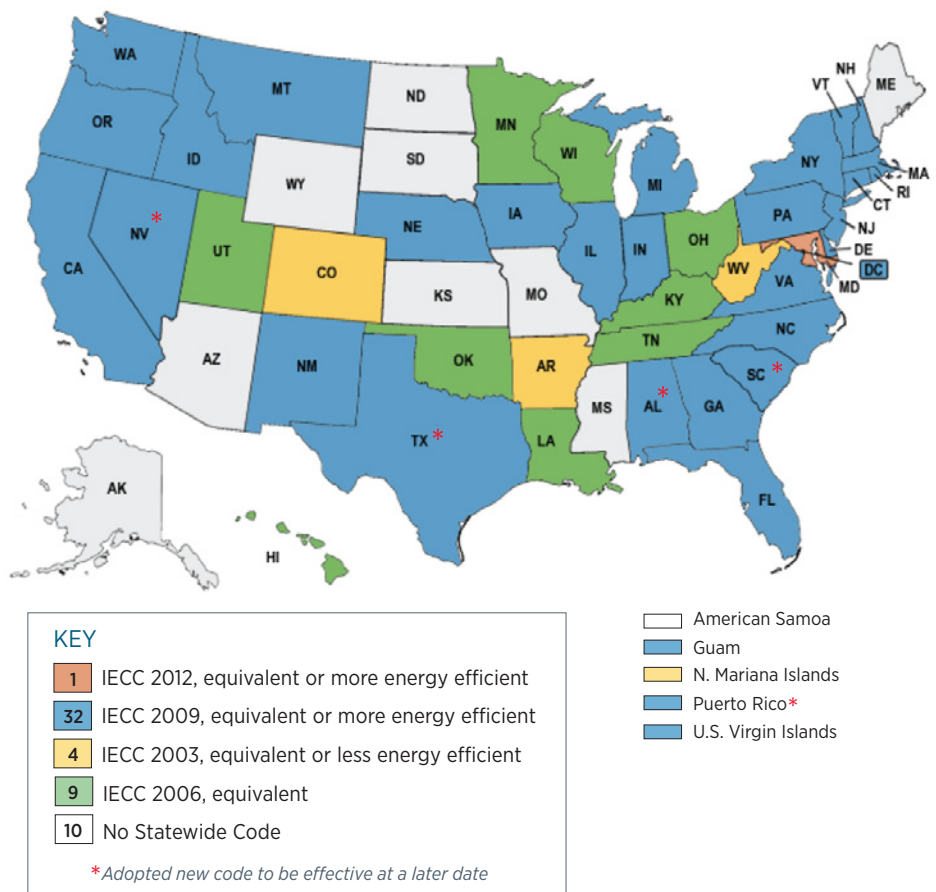


Figure 2.3. Adoption of IECC by State. As of Sept. 29, 2011 (Source: DOE BECP).

Table 2.1. Minimum Insulation Levels^a for New Homes as Required by the 2009 and 2012 International Energy Conservation Code.

Climate Zone	Ceiling R-Value		Wood Frame Wall R-Value ^b		Mass Wall ^c R-Value		Floor R-Value ^d		Basement Wall ^e R-Value		Slab R-Value ^f and Depth		Crawlspace ^g Wall R-Value	
	2009 IECC	2012 IECC	2009 IECC	2012 IECC	2009 IECC	2012 IECC	2009 IECC	2012 IECC	2009 IECC	2012 IECC	2009 IECC	2012 IECC	2009 IECC	2012 IECC
1	30	30	13	13	3/4	3/4	13	13	0	0	0	0	0	0
2	30	38	13	13	4/6	4/6	13	13	0	0	0	0	0	0
3	30	38	13	20/13+5 ^{b,d}	5/5	8/13	19	19	5/13 ^h	5/13 ^h	0	0	5/13	5/13
4 except Marine	38	49	13	20/13+5 ^{b,d}	5/10	8/13	19	19	10/13	10/13	10, 2 ft.	10, 2 ft.	10/13	10/13
5 and Marine	38	49	20/13+5 ^{b,c}	20/13+5 ^{b,d}	13/17	13/17	30 ^f	30 ^f	10/13	15/19	10, 2 ft.	10, 2 ft.	10/13	15/19
6	49	49	20/13+5 ^{b,c}	20+5/13+10 ^{b,d}	15/19	15/20	30 ^f	30 ^f	15/19	15/19	10, 4 ft.	10, 4 ft.	10/13	15/19
7 and 8	49	49	21	20+5/13+10 ^{b,d}	19/21	19/21	38 ^f	38 ^f	15/19	15/19	10, 4 ft.	10, 4 ft.	10/13	15/19

Source: 2009 and 2012 IECC Tables 402.1.1

- R-values are minimums. When insulation is installed in a cavity which is less than the labeled design thickness of the insulation, the installed R-value of the insulation shall not be less than the R-value specified in the table
- The first value is cavity insulation, the second value is continuous insulation or insulated siding, so "13+5" means R-13 cavity insulation plus R-5 continuous insulation or insulated siding.
- If structural sheathing covers 25 percent or less of the exterior, insulating sheathing is not required where structural sheathing is used. If structural sheathing covers more than 25 percent of exterior, structural sheathing shall be supplemented with insulated sheathing of at least R-2.
- If structural sheathing covers 40% or less of the exterior, continuous insulation R-value shall be permitted to be reduced by no more than R-3 in the locations where structural sheathing is used - to maintain a consistent total sheathing thickness
- The second R-value applies when more than half the insulation is on the interior of the mass wall.
- Or insulation sufficient to fill the framing cavity, R-19 minimum.
- "15/19" means R-15 continuous insulated sheathing on the interior or exterior of the home or R-19 cavity insulation at the interior of the basement wall. "15/19" shall be permitted to be met with R-13 cavity insulation on the interior of the basement wall plus R-5 continuous insulated sheathing on the interior or exterior of the home. "10/13" means R-10 continuous insulated sheathing on the interior or exterior of the home or R-13 cavity insulation at the interior of the basement wall.
- Basement wall insulation is not required in warm-humid locations as defined by 2009 and 2012 Figure 301.1 and Table 301.1.
- R-5 shall be added to the required slab edge R-values for heated slabs. Insulation depth shall be the depth of the footing or 2 feet, whichever is less in Zones 1 through 3 for heated slabs.

Table 2.2. R-Values for Insulation Types Commonly found in Existing Homes

If you see:		It is probably	Total R-value
Loose fibers	Light-weight yellow, pink, or white	Fiberglass	Depth (inches) x 2.5 = R-value
	Dense gray or near-white, may have black specks	Rock wool	Depth (inches) x 2.8 = R-value
	Small gray flat pieces or fibers (from newsprint)	Cellulose	Depth (inches) x 3.7 = R-value
Granules	Light-weight gray, white	Vermiculite or Perlite	Depth (inches) x 2.7 = R-value
Batts	Light-weight yellow, pink, or white	Fiberglass	Depth (inches) x 3.2 = R-value

(Source: DOE 2008)



Unfaced fiberglass batt insulation



Faced fiberglass batt insulation



Loose fiberglass insulation



Vermiculite insulation



(Top) **Inspect the attic.** Check the evenness and depth of the insulation on your attic floor.

(Bottom) **Check under the floor.** Inspect the insulation of ducts, pipes, and the floors over a garage, basement, or crawlspace. In this crawlspace, the fiberglass batts are drooping slightly from the ceiling, reducing their R-value. The duct insulation needs new tape. In cold climates, the pipes should be insulated to prevent freezing.

(Photo Source: PNNL)

Existing Insulation Levels

Your energy contractor will check insulation levels in the attic, walls, and crawlspace or basement as part of a home energy assessment. You can get an idea of the R-value of existing insulation values yourself using the tips below. Table 2.2 will help you figure out what kind of insulation you have and what its R-value is.

LOOK IN YOUR ATTIC. Batt insulation that is faced with paper or foil will often have its R-value printed on the facing. If it's not faced, use a ruler to measure the depth and refer to Table 2.2 to estimate the R-value. The quality of the installation has a significant impact on performance. If you have loose-fill insulation, look for places where it is thin or missing, especially at the edges of the attic. If you have batts, look for ones that are squished or pushed aside in places to allow for wiring or recessed lights.

LOOK INTO YOUR WALLS. Your contractor will likely use an infrared camera that can show where heat is coming through the walls or ceilings, giving a clear picture of just where insulation is missing. You can check visually for wall insulation through an electrical outlet or switch plate. Turn off the power to the outlet, then remove the cover plate and use a flashlight to look into the crack around the outlet box. You can also use a crochet hook to see if you can retrieve some insulation (but be sure the power to the outlet is off). You should check separate outlets on the first and second floor, and in old and new parts of the house, because insulation in one wall doesn't necessarily mean that it's in every wall.

LOOK UNDER YOUR FLOORS. Look at the underside of the floor over a garage, basement, or crawlspace and measure the thickness of any insulation you find there. If the insulation is foam board or sprayed-on foam, use any visible label information or multiply the thickness in inches by 5 to estimate the R-value. If the insulation is fiberglass batt, multiply the thickness in inches by 3.2 to find out the R-value (or the R-value might be visible on a product label). R-value is greatly reduced when batts are pinched or drooping. Air can flow in convective loops between the sagging insulation and the floor above, robbing the insulation of its heat-trapping ability.

LOOK AT YOUR DUCTWORK. Don't overlook another area in your home where energy can be saved—the ductwork of the heating and air-conditioning system. Ducts should be insulated if they run through unheated or uncooled spaces in your home, such as an attic or crawlspace. R-value may be printed on the existing duct insulation.

LOOK AT YOUR PIPES. Water pipes should be insulated if they run through unheated or uncooled spaces in your home.

2.3 The Bottom Line: Is Adding Insulation Worth the Cost?

The potential for savings is different for every house. Your financial decision about adding insulation will depend on your climate, budget, and how much you are likely to save on energy bills. If your insulation is already adequate, adding more insulation may not be the best investment. You may not save enough energy to recoup the cost of the insulation. However, if your home is poorly insulated or you have high heating and cooling bills, added insulation is likely to pay for itself over time.

“Simple Payback”

The cost of the upgrade measures divided by the annual estimated savings will provide a “simple payback,” telling you how many years the measures will take to pay for themselves. If you have little or no insulation, especially in the attic, adding insulation is likely to pay for itself within a few years. For example, in a retrofit of a tri-level home built in eastern Washington in the 1970s, auditors found that air sealing and insulating the attic would cost an estimated \$1,131. With a projected annual savings of \$239 a year, the owners will recoup their investment in five years. After that, the \$239 a year will be money in their pocket (DOE 2011f). For more on estimating insulation payback, see www.energysavers.gov/your_home/insulation_airsealing/index.cfm/mytopic=11360.

Grants and Tax Credits

Many local, state, and federal agencies offer grants and tax credits for energy-efficient home improvements. Check with your local utility or city, or check the DOE-sponsored Database of State Incentives for Renewables and Efficiency (www.dsireusa.org). Organized by state, this site is frequently updated and has a wealth of information regarding federal, state, local, and utility incentives and tax credits.

Profile

Insulation and Air Sealing Create a Cool, Comfortable Home



Air seal before insulating. This 1950s home in Pasadena needed better insulation. However, insulation would not have stopped the constant flow of air in and out of the house. Blower door testing showed air leakage of 13,523 cfm at 50 Pascals of pressure; 5,000 cfm is typical in an older home; 1,000 cfm is ideal (Photo Source: DOE).



The home energy assessment found 52 recessed “can” lights that allowed conditioned air to escape into the attic. To stop the leaks, workers built air-tight boxes over each light. They also inspected the attic to close off other air leaks over ceiling soffits. They also closed off the vented crawlspace; sealed leaks around wiring, ducts, and plumbing pipes; and replaced old rusted ducts that were dumping conditioned air into the crawlspace. Sealing air leaks in the attic, crawlspace, and floor cut air leakage by 45%. These measures, combined with adding R-38 attic insulation, cut the home’s energy bill in half (Photo Source: DOE).

Source: DOE Building America, www.buildingamerica.gov

3.0 Types of Insulation



Insulation is made of a variety of materials that have a high thermal resistance, which means resistance to heat flow. The unit of measure for a material's thermal resistance is its R-value. The R-value of insulation depends on the type of material, its thickness, and its density. The higher the R-value, the greater its insulating effectiveness.

The “best” type of insulation for your home depends on where you plan to install it, the R-value recommended for your climate, and the cost of buying and installing the material. Some types of insulation require professional installation; others you can install yourself.

3.1 Insulation Summary Tables

The tables that follow will help you choose the best insulation for your project. The tables provide information in three ways:

Table 3.1 provides information about forms of insulation, such as batts, loose-fill, spray-on, and rigid board. The table describes the advantages and disadvantages of each, the best applications for each form, and installation tips.

Table 3.2 provides information about insulation materials, such as cellulose, fiberglass, and polystyrene. The table gives R-values for each material and describes its advantages and disadvantages.

Some insulation materials are also vapor retarders. Vapor retarder requirements are defined and specified in the International Residential Code as shown in Section 3.2.

Get a Whole-House Energy Checkup First

Before beginning any insulation project, be sure to get a whole-house energy checkup. This assessment will identify the most effective improvements for your home and help you avoid unintended consequences. Because your house is a system and all its components work together, adding insulation can affect how other components perform. Moisture management and ventilation, for example, are major issues to address in your insulation plans. See Appendix B for more information on moisture, air leakage, ventilation, and the whole-house approach of building science.



Costs

Table 3.2 shows the relative cost of many insulation types. DOE's National Renewable Energy Laboratory has also prepared a database of costs of various home energy-efficiency upgrades including insulation. This can be found at www.eere.energy.gov/buildings/building_america/measures_costs.html

Table 3.1. Forms of Insulation

Form of insulation	Type of insulation material	Areas for use	Advantages	Disadvantages	Installation
Batts and blankets made in standard widths. Batts are precut. Blankets come in rolls.	Flexible, woven fibers, made of: Fiberglass, Mineral wool, Cotton, or Sheep's wool	Open walls; attic floor and kneewalls; basement or crawlspace ceiling in dry climates only	Relatively easy to install. Available unfaced or with facings (kraft paper, foil-kraft paper, or vinyl) for air and/or vapor resistance. Batts with flame-resistant facing are available for basement walls in which the insulation will be left exposed.	Not air-tight. Careful installation is necessary to reduce air leaks around edges, which significantly reduce R-value. Subject to air movement around and through the batts. Hard to fit into irregular spaces. Loses R-value when compressed. Nesting material for rodents.	Batts are hand-cut and trimmed to fit. The batt must fill the entire cavity without any gaps. Batts must not be folded, tucked-in, or pinched. Slit batts to fit around wiring and plumbing. Improper installation reduces effectiveness. Facing material should face the 'warm-in-winter' side to resist condensation in walls.
Blown-in, loose-fill fiber	Small particles of: Cellulose, Fiberglass, or Mineral wool	Attic floor, walls, vaulted ceilings	Inexpensive. The small particles conform to the space into which they are blown. Well suited for retrofits. Fills spaces behind and around obstacles, such as electrical boxes, wiring, plumbing, and nails.	Typically requires a professional installer. Must be applied using an insulation blowing machine. Some types have high water absorption. Can have settlement problems if not installed properly. Dusty. For wall retrofits, requires drilling of wall sheathing to gain access to wall cavities.	Blown with a pneumatic hose into open attics, or blown through holes drilled into the framing cavities of existing walls, floors, or vaulted ceilings. Use baffles to keep fiber away from soffit vents in attics. Don't cover recessed light fixtures unless the fixtures are ICAT rated. Insulation must be kept away from chimneys and metal flues.
Blown-in, dense-pack fiber	Small particles of: Cellulose, or Fiberglass	Walls, cathedral ceilings	Inexpensive. Conforms to the space into which it is blown. Fully fills spaces behind and around obstacles. Some air sealing ability.	For wall retrofits, requires drilling of wall sheathing to gain access to wall cavities. Walls must be well air-sealed and strong enough to accommodate added pressure.	Like loose-fill, except the fibers are blown at relatively high density into a wall or ceiling cavity to resist air infiltration. Note cautions above regarding attic vents and hot objects.
Sprayed-on fiber mixed with water and adhesives	Fibers mixed with wet adhesive: Cellulose, Fiberglass, or Mineral wool	Basement walls; walls with siding removed	Conforms to the space into which it is blown. Fully fills spaces behind and around obstacles.	Typically requires a professional installer. Requires interior drywall to be removed to install and to allow drying.	Fibers are mixed with wet adhesive and sprayed into open wall cavities, then allowed to dry.

Form of insulation	Type of insulation material	Areas for use	Advantages	Disadvantages	Installation
Sprayed-on foam	Polyurethane, Castor- or soy-based polyurethane, Cementitious	The perimeter of vented attics; roof deck of cathedralized attics; vaulted ceilings; flat roofs; basement walls; walls with siding removed	Excellent air barrier; can eliminate the need for separate air-tightness detailing. Very resistant to moisture, especially when treated with sealant. Fills even the smallest cavities, including spaces around obstacles such as electrical boxes, wiring, plumbing, and nails.	Expensive. Installation requires a trained installer. Limited attic access may impede proper installation. Hydrofluorocarbons (potent greenhouse gases) usually used in production or application. Foam insulation can be damaged by sunlight and high temperature. It produces toxic smoke when burned.	Blown through a membrane with air. Requires special equipment. Sprayed into cavities, where it expands to fill all spaces. All types of foam insulation must be protected from direct sunlight. Must be covered with a fire barrier.
Rigid insulation	Molded and hardened fibers or foam: Polyisocyanurate Expanded polystyrene (EPS), Extruded polystyrene (XPS), or Polyurethane Fiberglass	Above rafters in cathedralized attic; vaulted ceilings or flat roofs; exterior walls under siding; basement and crawlspace walls; under concrete floors; slab perimeters	High R-value per inch of thickness. An air barrier and vapor retarder if seams are properly sealed. Blocks thermal bridging. When replacing siding, can add insulation to walls without removing interior drywall or drilling.	Expensive. Does not conform to irregular surfaces. Requires careful installation to limit gaps and air leaks. Can be damaged by sunlight and high temperature. Produces toxic smoke when burned.	Attached directly to framing. Must be protected from direct sunlight. In basements, must be covered with an ignition barrier, such as wood paneling or ½-inch drywall.
Exterior rigid foam blocks	Molded and hardened expanded polystyrene foam	Exterior walls under siding	When replacing siding, can add insulation to walls without removing interior dry wall or drilling. High R-value prevents condensation problems. Blocks thermal bridging.	Due to thickness of foam blocks, adjustments of windows and doors may be required. Some types require the installer to cut utility chases. Must avoid contact with soil.	A steel starting track holds the first row of blocks. Subsequent rows are attached with plastic clips and attached to walls with furring strips. Can be covered with any siding.
Reflective Insulation	Aluminum foil with paper or foam backing	Vented attics in hot-dry and hot-humid climates	Reduces solar heat gain. Can be combined with many types of insulation. Can be cost-effective as a radiant barrier in attics in hot climates, especially if duct system is in attic.	Radiant barriers not recommended for cold climates. Not for use in unvented attic. The more attic insulation, the less cost-effective the radiant barrier will be.	Requires an air space adjacent to the reflective surface. Stapled on the underside of rafters or on top of ceiling. To avoid moisture problems, do not install radiant barriers in contact with attic floor insulation.

Table 3.2. Insulation Materials

Note: All R-values are approximate and for general comparison only (Source for R-values: DOE (DOE 2008b; Krigger and Dorsi 2009)

What is it?	Product form	R-value per inch	Advantages	Disadvantages	Relative Costs
Cellulose insulation					
Recycled newsprint, finely shredded and chemically treated to resist fire, corrosion, fungal growth, and vermin. Loose-fill is most suitable for existing homes.	Blown-in, loose-fill	R-2.9 to R-3.4	Inexpensive. Contains at least 70% recycled paper. Commonly used for energy upgrades in existing homes.	Requires chemical treatment with fire retardant. Cellulose must be kept away from chimneys and metal flues. Address mold issues before installing cellulose. Accidental wetting and high humidity can cause cellulose to absorb large quantities of water, reducing thermal resistance, draining fire retardant, and creating risk of mold and moisture damage to building components.	\$
	Blown-in, dense-pack	R-3.0 to R-3.4			\$
	Sprayed-on	R-3.6 to R-3.8			\$
Cementitious insulation					
Magnesium oxide from sea water.	Sprayed-on foam	R-3.9	Excellent air barrier. High fire and mold resistance. Non-toxic. Does not offgas any volatile chemicals. Does not shrink or settle.	Expensive. Must be applied by a trained installer. Few installers trained in this specialty. Expands as it sets and can crack walls if installed incorrectly. Can be fragile or brittle if exposed to frequent vibration, reducing its performance.	
Cotton insulation					
Low-grade, recycled, or waste cotton. Borate treated for pest and fire resistance.	Batts	R-3.4	Nontoxic.	Limited availability. Batts may not be sized for standard stud cavity widths. Difficult to cut. Absorbs moisture, does not insulate when wet. Water can carry away pest and fire retardant.	\$\$\$
Fiberglass					
Glass spun into long fibers and woven. May contain 30% or more post-consumer recycled glass. Batts come with or without vapor-retarder facings such as kraft paper, foil-kraft paper, or vinyl.	Batts	Standard density: R-2.9 to R-3.8 High density: R-3.7 to R-4.3	Batts are inexpensive. Excellent fire and moisture resistance. Resistant to mold and pests. R-value depends on density.	Installation requires protective measures to prevent skin and eye contact. Gaps between batts may allow air infiltration or condensation, reducing effectiveness. Batts are not an air barrier. Available with kraft paper, foil-kraft paper, or vinyl facings to act as a vapor retarder. Kraft paper facing is flammable. Some brands contain formaldehyde, a toxic gas.	\$
Glass spun into long fibers and woven. May contain 30 percent or more post-consumer recycled glass.	Blown-in, loose fill	R-2.2 to R-2.7	Produces little dust during installation. Non-flammable.	Blown fiberglass: Many blowing machines over-fluff fiberglass in attics, reducing density and R-value. Blown-in fiberglass requires careful protective measures to prevent breathing of fibers and skin and eye contact. Must be fully enclosed to prevent entry of glass particles into living spaces.	\$
	Blown-in, dense-pack	R-3.6 to R-4.4			\$
	Rigid board	R-2.2 to R-4.3	Excellent for soil contact.	Rigid board can be expensive.	\$\$
Mineral wool					
Slag (a non-metallic by-product of steel-making) or rock, melted and spun into fibers.	Batts	R-3.7	Non-combustible. Excellent sound insulation.	Absorbs water. Vapor permeable. For batts: Improper installation reduces effectiveness; loses R-value when compressed. May not be readily available.	\$\$
	Loose-fill	R-3.7			
	Sprayed-on	R-3.7			

What is it?	Product form	R-value per inch	Advantages	Disadvantages	Relative Costs
Polyisocyanurate					
A petroleum product. Can be partially soy-based.	Rigid foam board	R-5.6 to R-8; R-7.1 to R-8.7 with foil facing	Highest R-value per inch, which is valuable when space is limited. When faced with aluminum foil, foil facing protects surface, retains R-value, and serves as vapor retarder.	Expensive. Requires a fire barrier. Should not be used in contact with soil. Its closed cells contain low-conductivity gas. Over time, R-value decreases as some of the gas escapes and is replaced by air. Foil and plastic facings can help stabilize the R-value.	\$\$\$
Polystyrene – Expanded (EPS)					
A petroleum product. Also known as bead board.	Rigid foam board	R-3 to R-4	The least expensive foam board. Comes in many densities and grades.	Absorbs some water. Not a vapor retarder. Requires a fire barrier. Melts at 200°F.	\$\$\$
	Exterior and interior rigid foam block systems	R-10 to R-26	When replacing siding, provides high R-value for walls without drilling or removing interior dry wall. Can be covered by any type of siding.		
Polystyrene – Extruded (XPS)					
A petroleum product.	Rigid foam board	R-5.0	High R-value per inch. Excellent moisture resistance. Good vapor retarder. Preferred material for soil contact or as rain shield.	Requires a fire barrier. Melts at 300°F. Requires a capillary break between soil and insulation. Hydrochlorofluorocarbon, a potent greenhouse gas, used in production.	\$\$\$
Polyurethane					
Petroleum or soy or castor-based product.	Rigid foam board	R-7 to R-9		Requires a fire barrier.	\$\$\$
	Spray foam: closed-cell, medium-density	R-7 to R-9	Very resistant to moisture. Excellent air barrier; can eliminate the need for separate air-tightness detailing. Great adhesion. Closed-cell foam strengthens a structure. Closed-cell foam is a vapor retarder.	Expensive. Installation difficult. Requires a fire barrier.	\$\$\$\$
	Spray foam: Open-cell, low-density	R-3.5 to R-3.8	Not a vapor retarder. Is an air barrier	Expensive. Installation difficult.	\$\$\$\$
	Spray foam with castor or soy oil	R-values comparable to 100% polyurethane foam	Available in both open- and closed-cell types.	Expensive. Installation difficult. Requires a fire barrier.	\$\$\$\$
Radiant barrier					
Aluminum foil with backing		N.A.	Reduces attic temperatures. Cost-effective in hot climates.	Not recommended and not cost-effective for cold climates. May create moisture problems. Not for use in unvented attic.	
Sheep's wool					
Sheep's wool and borate	Batts	R-3.5	Borate-treated for pest, mold, and fire resistance. Maintains insulation effectiveness when moist.	Repeated wetting and drying can carry away the pest and fire retardant.	\$\$\$
	Loose-fill				

Vapor Retarder Definitions

The 2009 IRC R601.3 gives the following definitions and examples for vapor retarder classes:

Class	Definition	Examples
I	0.1 perm or less	Sheet polyethylene, sheet metal, non-perforated aluminum foil
II	Greater than 0.1 perm to less than 1.0 perm	Kraft-faced fiberglass batts or low-perm paint
III	Greater than 1.0 perm to less than 10 perm	Latex or enamel paint

Class III Vapor Retarders Permitted in Cold Climate Under Following Conditions

(Source: 2009 IRC Table R601.3.1)

Zone	Class III vapor retarders permitted for:
Marine 4	<ul style="list-style-type: none"> Vented cladding over OSB Vented cladding over plywood Vented cladding over fiberboard Vented cladding over gypsum Insulated sheathing with R-value \geq R-2.5 over 2x4 wall Insulated sheathing with R-value \geq R-3.75 over 2x6 wall
5	<ul style="list-style-type: none"> Vented cladding over OSB Vented cladding over plywood Vented cladding over fiberboard Vented cladding over gypsum Insulated sheathing with R-value \geq R-5 over 2x4 wall Insulated sheathing with R-value \geq R-7.5 over 2x6 wall
6	<ul style="list-style-type: none"> Vented cladding over fiberboard Vented cladding over gypsum Insulated sheathing with R-value \geq R-7.5 over 2x4 wall Insulated sheathing with R-value \geq R-11.25 over 2x6 wall
7 & 8	<ul style="list-style-type: none"> Insulated sheathing with R-value \geq R-10 over 2x4 wall Insulated sheathing with R-value \geq R-15 over 2x6 wall

3.2 Vapor Retarders

Some forms of insulation also serve as vapor retarders. Water vapor can be a source of damage when it is trapped within a building assembly and cannot dry out. Most water vapor movement in and through buildings is via air. Warm air carries more water vapor than cold air. When warm air touches a cold surface, the water vapor it carries can condense, turning the vapor into its liquid form, where it can cause damage to structural components. Stopping air leaks by thoroughly air sealing the building envelope is an important step in limiting damage from water vapor. Water vapor can also be carried through building components by diffusion, driven by pressure and temperature differences. Vapor diffusion can be impeded by use of a vapor retarder. The 2009 International Residential Code (IRC) defines vapor retarders based on their permeability; the higher the perm rating, the more easily water vapor can pass through the material (see Vapor Retarder Definitions table). Some builders refer to Class 1 vapor retarders as vapor barriers but the code no longer uses the term vapor barrier.

The 2009 IRC R601.3 specifies the use of Class I or II vapor retarders on the interior side of framed walls (between the insulation and the drywall) in IECC climate zones 4c, 5, 6, 7, and 8 (see IECC map page 10). However, per a change in the 2009 IRC from the 2006 IRC, Class III vapor retarders (e.g., latex paint) are now permitted in all of these climate zones when the wall is constructed in a way that allows drying through the use of vented cladding (e.g., brick or lap siding with an air space behind it) or reduces the potential for condensation by the use of insulating rigid foam sheathing (see Class III Vapor Retarders table). Building America scientists caution that the recommendation to install a vapor barrier on the “warm-in-winter” side of the wall assemblies is difficult to apply in mixed climates or climates that are air conditioned in summer. They recommend that walls should be allowed to dry to the inside, the outside, or both sides and they don’t recommend the use of Class I vapor retarders in any but the coldest climates.

In older homes Class 1 vapor retarders (like plastic sheeting) were often installed on the interior side of the walls in all climate zones. If the walls are very drafty, due to lack of insulation and air sealing, drying can still occur. When insulation and air sealing are added, consideration should be given to any existing vapor retarders to minimize the likelihood of condensation problems.

For more on vapor retarders see Appendix B.4, also Lstiburek 2004b, d; 2006e.

4.0 Insulation—Safety and Health Issues



When you air seal and insulate your home, you need to address some issues of health and safety. This chapter describes these issues and provides steps you and your contractor should take before you begin your project.

4.1 Health and Safety Steps: Do These Before You Insulate

TEST COMBUSTION APPLIANCES. Air sealing and adding insulation can alter the pressure and movement of air inside a home. (See Appendix A for a short primer on heat flow and air pressure in homes.)

Air pressure imbalances can sometimes cause fireplaces, furnaces, stoves, water heaters, and other non-closed combustion appliances that burn fuel (such as wood and natural gas) to pull exhaust gases back into the house instead of letting them vent up the flue. This situation is known as backdrafting. Carbon monoxide, a toxic gas without odor and color, can backdraft into homes, causing illness and death. If a combustion appliance has a pilot light flame, backdrafting, air pressure imbalances, or mechanical problems can cause the pilot light to blow out. Worse, the flame can “roll out” of the appliance, causing a house fire.

Before work begins and again when the project is complete, your contractor should test chimneys and all combustion appliances to ensure they have proper draft and emit little or no carbon monoxide. To check the safety of any combustion appliances in the home, your contractor should conduct a worst-case depressurization test using blower door equipment.

Backdrafting risks. Before beginning air sealing and insulation work, your contractor should test any combustion appliances, like this atmospheric-vented gas water heater, to ensure proper draft. Negative air pressure inside a home can cause fireplaces and fuel-burning appliances to backdraft, pulling dangerous carbon monoxide into the home. Your contractor should perform the combustion safety tests again when your project is complete (Photo Source: PNNL).





Maintain air quality. (Top) Adequate ventilation can include simple measures like installing high-efficiency bath fans that are ducted to the outside.

(Middle) A garage fan can help remove fumes from car exhaust and chemicals.

Knob and tube wiring. (Bottom) If a home energy checkup reveals that you have old knob-and-tube wiring anywhere in your house, don't add insulation until the wiring has been replaced with new, insulated electrical wiring.

(Photo Source: PNNL)

If at all possible, replace natural draft (“draft-hood-equipped”) combustion appliances with sealed-combustion, induced-draft, or power-vented appliances. Homes with combustion appliances should have carbon monoxide detectors that meet UL 2034.

VENTILATE WELL TO PREVENT AIR POLLUTION AND MOISTURE PROBLEMS.

Many homes contain hazardous substances, such as cigarette smoke, cleaning chemicals, pesticides, and offgases from carpets, paints, finishes, and home electronics. Good ventilation and exhaust fans are essential before you air seal and add insulation. Otherwise, these pollutants will become more concentrated inside the home.

Poor ventilation also allows water vapor from showering, cooking, and breathing to concentrate in the home. This can lead to problems with mold, mildew, dust mites, wood rot, and building damage.

Oftentimes, a mechanical ventilation system is needed to supply fresh air once a home is air-sealed. Your contractor should make sure your ventilation system does not create depressurized areas inside the home and make sure all duct work is properly sealed.

REPLACE ACTIVE KNOB-AND-TUBE WIRING. For fire safety, active knob-and-tube wiring should be replaced before your contractor begins the insulation project. Insulation can cause the wiring to overheat, creating a fire risk.




CHECK FOR RADON. If radon is present in the soil under your home, air sealing your basement or crawlspace can lead to increased concentrations indoors (Hale 2011; DOE 2010b). Radon causes cancer. It is a naturally occurring gas that comes from the radioactive breakdown of uranium in soil. It is odorless, tasteless and invisible. The gas typically moves up through the ground and into your home through air leaks and cracks. According to the EPA, there is no level of radon known to be safe (EPA 2011e).

Nearly 1 out of every 15 homes in the United States is estimated to have high radon levels (EPA 2011e). The level of radon in soil varies from area to area, but radon beneath any particular home can be high. The only way to know whether radon is accumulating in your home is to test for it. Low-cost “do-it-yourself” radon test kits are available in stores.

Before air-sealing work begins, your contractor should check for radon. If found, do not proceed until the radon problem is addressed. This is especially important if your project includes air-sealing your crawlspace or basement.

If the radon level in your home is elevated, you must reduce it to protect your health. A qualified radon contractor can advise you on the best radon remediation system for your home. The most common method is soil suction, which draws the radon from below the home and vents it through a pipe to the roof. The particular soil suction technique depends on what type of foundation a home has. Costs vary.

After your air sealing and insulation project is complete, test again for radon.

Highest Potential		Zone 1 counties have a predicted average indoor radon screening level greater than 4pCi/L (picocuries per liter)
Moderate Potential		Zone 2 counties have a predicted average indoor radon screening level between 2 and 4 pCi/L
Low Potential		Zone 3 counties have a predicted average indoor radon screening level less than 2 pCi/L

More information on radon

Radon in homes causes an estimated 20,000 lung cancer deaths each year (EPA 2011e). For more information, see www.epa.gov/radon/aboutus.html.

The U.S. Environmental Protection Agency (EPA) designates zones as having high, moderate, or low potential levels of radon (Figure 4.1).

The EPA recommends installing a radon control system if the level in your home exceeds 2 to 4 picocuries per liter (pCi/L) of air. The EPA requires radon control above 4 pCi/L. For more testing information, see www.epa.gov/radon/pubs/citguide.html.

To find a qualified or state-certified radon contractor, check with your state radon office or see www.epa.gov/radon/whereyoulive.html.

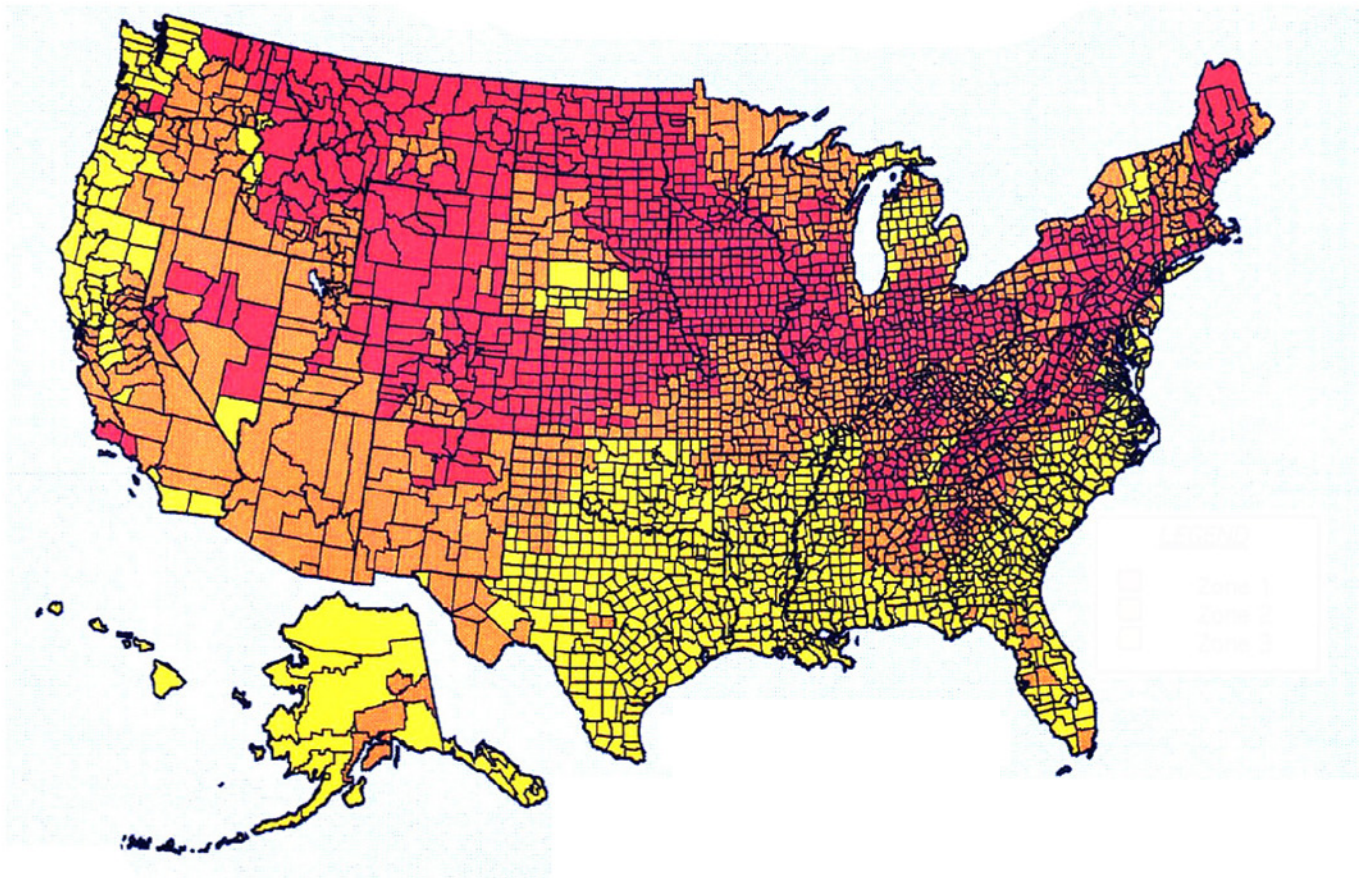
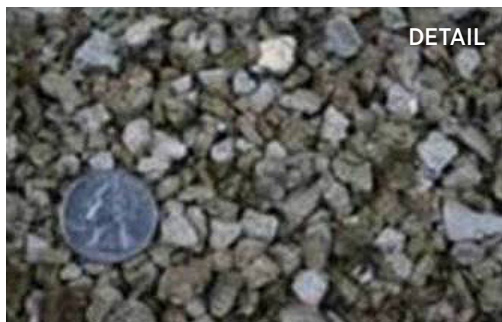


Figure 4.1. Radon Potential in the U.S. by County. This map shows predicted average indoor radon levels by county. Be sure your home is tested because radon accumulation can vary from home to home (Figure Source: EPA 2011c).



Vermiculite insulation. If you have vermiculite insulation in your attic or walls, you should assume that it contains asbestos and be careful to avoid exposure. Vermiculite was commonly used before 1990 (Photo Source: EPA).

For more information on vermiculite insulation

www.epa.gov/asbestos/pubs/insulation.html#What

For more information on asbestos

www.epa.gov/asbestos/

4.2 Insulation Products: Health and Safety Concerns

Insulation work can pose safety challenges that are best left to professionals. Two older types of insulation are known health hazards – asbestos and urea-formaldehyde. Installing new insulation requires knowledge and skill. Your energy contractor will help you choose the right product and install it properly, ensuring the health of your home environment.

Vermiculite Insulation and Asbestos

Until 1980, **asbestos** was widely used in building materials such as ceiling and floor tiles. It was also used as insulation for furnaces, boilers, and water pipes. Asbestos is a naturally occurring mineral fiber that can cause lung disease and cancer.

Until 1990, an insulation product called vermiculite was widely used in homes, and much of it was contaminated with asbestos. Over 70% of the vermiculite sold in the United States came from a mine near Libby, Montana, which was found to have natural asbestos deposits.

If you have **vermiculite insulation** in your attic or walls, you should assume that it contains asbestos and take steps to protect yourself and your family from exposure. If asbestos is damaged or disturbed, microscopic fibers become airborne and may be inhaled. The most dangerous asbestos fibers are too small to see. There is no known safe level of asbestos exposure.

If you are planning an insulation project and suspect you have vermiculite insulation or another form of asbestos in your home, don't touch it. Disturbing the material releases fibers into the air. Don't make openings in your walls to check for vermiculite.

If you have vermiculite insulation in your attic, avoid going into the attic. Warn any contractors doing work in your attic that they may be exposed to asbestos and must avoid disturbing the vermiculite.

The U.S. Environmental Protection Agency makes the following recommendations for homes that contain vermiculite:

- Leave the vermiculite insulation undisturbed in the attic or walls.
- Do not store boxes or other items in the attic.
- Keep children away from it.
- Do not attempt to remove the vermiculite yourself.

If your home improvement plans require disturbing vermiculite or asbestos, you must hire a professional asbestos contractor. The professional will have two options: repair or removal. Repair usually involves sealing or covering asbestos material; this option costs less than removal. Removal increases the risk of fiber release. Unless it is required by state or local regulations, it should be your last option in most situations. Your state health department can provide a list of contractors certified to perform this work.

Urea-Formaldehyde Foam Insulation

Urea-formaldehyde foam was a popular insulation in the 1970s. It looks like an oozing liquid, although it is solid, dry, and crumbles easily. With age, it turns butterscotch in color. You may find it in basements, attics, crawlspaces, and unfinished closets.

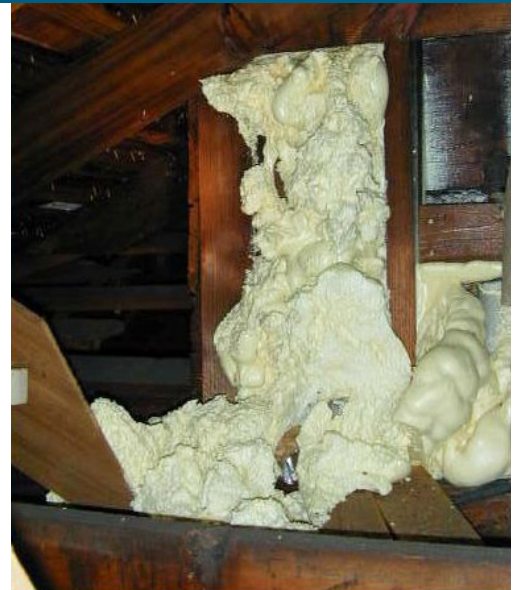
Because it offgasses formaldehyde, urea-formaldehyde insulation can cause eye and lung irritation, headaches, and dizziness in some individuals. In the early 1980s, the U.S. Consumer Product Safety Commission (CPSC) banned its use in homes and schools. Formaldehyde itself, however, is still widely used to make resins for a variety of household items, including fiberglass insulation (see next section). In June 2011, the U.S. Department of Health and Human Services classified formaldehyde as a known human carcinogen. Their report concluded that individuals with “higher measures of exposure to formaldehyde” are at increased risk for certain types of rare cancers (NIH 2011).

Old urea-formaldehyde insulation is unlikely to cause problems. According to the CPSC, the release of formaldehyde decreases rapidly after the first few months and reaches background levels in a few years. However, sensitivity to formaldehyde varies from person to person, and unsealed foam may still release small amounts of the gas, especially when wet or hot.

If you have exposed urea-formaldehyde foam in your home, you should consult a professional hazard abatement contractor about the best way to seal it off. If renovation work requires removal, it should be done by a hazard-abatement professional. Your state health department can provide a list of contractors certified to perform this work. Removal is expensive.

Fiberglass Insulation

Fiberglass insulation irritates skin and lungs. Some people are more sensitive than others. The U.S. Department of Health and Human Services has concluded that certain glass fibers are “reasonably anticipated to be human carcinogens,” but this refers only to glass



Urea-formaldehyde foam insulation.

If possible, leave this insulation undisturbed. Removal should be done by a hazard-abatement professional (Photo Source: Nachi.org).

For more information on urea-formaldehyde foam insulation

www.cpsc.gov/cpsc/pub/pubs/725.pdf

www.epa.gov/iaq/formalde.html#Levels%20in%20Homes



Fiberglass. Take care when handling fiberglass insulation, which can irritate skin and lungs. Keep kraft facing on batts away from hot fixtures. Install vent baffles to keep loose-fill insulation from blocking attic vents. Blocked vents can lead to problems with moisture, mold, and wood rot (Photo Source: PNNL).

See Appendix C for performance briefs on insulating and air sealing around

- Flue and chimney shafts
- Recessed light fixtures
- Duct boots and duct chases.

fibers that are small enough to be inhaled, are highly durable, and remain in the lungs for long periods of time (NIH 2011). While fiberglass insulation is made up of larger fibers, some very small fibers may be present (NIH 2009). Cancer risk is generally tied to high levels of exposure.

Formaldehyde, a toxic gas, may also be an issue. Formaldehyde-free **fiberglass batts and blankets** are available, but some brands are bound with resins that contain small amounts of formaldehyde.

Care should be taken when installing fiberglass insulation near hot fixtures. Fiberglass itself is noncombustible, but the resin binders it contains are combustible, as are some of the facings commonly used on batts. Kraft-paper facing should not be placed in contact with a chimney, flue pipe, or recessed light fixture. See Appendix C for instructions on constructing barriers to keep insulation from contacting chimneys, flue pipes, and recessed light fixtures.

Care should also be taken when installing **blown fiberglass** insulation in attics where ducts are located. Ducts must be properly sealed to keep fibers from being drawn into air distribution systems and then circulated within the living space.

To avoid moisture problems, be sure that blown insulation does not cover attic eave vents. If you are putting additional insulation on top of fiberglass batts, there should be no facing between the layers. Facing between the layers can act as a vapor retarder and create problems with moisture and mold. If you already have faced batts on your attic floor with the facing on top, do not put insulation over them.

Mineral Wool Insulation

As with fiberglass batts, formaldehyde-free **mineral wool batts** are available, but some batts are bound with resins that contain small amounts of formaldehyde, a toxic gas.

Plastic Foam Insulations: Polyurethane, Polystyrene, and Polyisocyanurate

All **plastic foam insulation**, whether spray foam or rigid board, can pose a health risk if it burns. Plastic foam insulation ignites at high temperatures and emits a dense smoke containing toxic gases, including carbon monoxide. (Cementitious foam, in contrast, is fire resistant and non-toxic, but not as widely available.) Plastic foam insulation must be covered with a thermal barrier to retard the spread of fire. For interior walls, ½-inch gypsum board is sufficient.

Metal flashing should be used to keep rigid foam insulation away from hot fixtures, such as chimney flues and non-insulation-contact rated recessed “can” lights. For instructions, see the Performance Briefs in Appendix C on chimney flues and recessed lights.

Polyurethane spray foam emits toxic gases during application. Inhalation and skin and eye contact are hazardous. The foam must be installed by trained professionals, in strict accordance with manufacturer recommendations and local building and fire codes. Your contractor should ensure good ventilation and use a respirator, goggles, face mask, and protective clothing. Some experts suggest that residents stay out of the home for as long as 24 hours after the application is completed.

Rigid **polystyrene foam** insulation contains styrene, which is on a list of products that are “reasonably anticipated to be human carcinogens.” According to the U.S. Department of Health and Human Services, workers are at risk who breathe indoor air that has styrene vapors from building materials, tobacco smoke, and other products (NIH 2011).

Cellulose Insulation

Although it is treated with fire retardant, **cellulose** may smolder if temperatures become hot enough. For instructions on keeping cellulose away from chimney flues and recessed “can” lights, see the Performance Briefs in Appendix C.

Before installing cellulose insulation in an attic where ducts are located, be sure to have a contractor seal the ducts to keep fibers from being drawn into the air distribution system. (See Appendix C, Duct Sealing.) In vented attics, use baffles to keep cellulose insulation from covering the soffit vents. Blocked vents can lead to severe moisture problems.

Safety and Health: The Bottom Line

Your house is a system, and every component in it works together. Changing one component, such as insulation, can dramatically affect how other components perform. Building America strongly recommends getting a whole-house energy checkup before you begin your insulation work. Your energy contractor will use the results to plan your project, choose appropriate products, and help you avoid unintended consequences that could affect your health and safety.



Polyurethane foam insulation. Leave the installation of spray foam to trained professionals. Toxic gases emitted during application are hazardous to skin, eyes, and lungs (Photo Source: NAHB).

For contractors:

Installing polyurethane or other foam insulations can involve significant safety risks. Check safety protocols at:

The National Institute for Occupational Safety and Health (NIOSH), www.cdc.gov/niosh/construction/

The Occupational Safety and Health Administration (OSHA), www.osha.gov/pls/oshaweb/owasrch.search_form?p_doc_type=STANDARDS&p_toc_level=1&p_keyvalue=Construction

Safety tests. A whole-house energy checkup that includes testing in and testing out of combustion equipment can help you achieve the most cost-effective energy efficiency gains while helping to ensure health and safety (Photo Source: PNNL).



5.0 How to Add Insulation



This chapter provides guidance in choosing the best strategies for insulating each part of your home. It describes best practices, explains issues that must be addressed, and identifies pitfalls to avoid. The recommendations are supported by real-world building science research conducted by Building America partners.

This chapter provides guidance for insulating the following areas:

5.1 Attics

5.2 Cathedral ceilings and flat roofs

5.3 Exterior walls

5.4 Crawlspace

5.5 Basements

5.6 Concrete floors.

To identify problem areas and prioritize projects, begin with a home energy assessment. Be sure to work with a contractor who has earned certification from a nationally recognized organization to perform energy upgrades (see Chapter 2).

Before you add insulation, air sealing your home to reduce air leakage is essential. Air leaks carry both moisture and heat, usually in the direction you don't want. Most insulation does not stop airflow.

Air flows through any available hole or crack in your home, leading to:

- **Energy loss.** In a typical home, air leakage accounts for 25% to 40% of the energy produced by your heating and cooling equipment.

Air sealing. Cracks and gaps that allow air to move in and out of the home can be sealed with spray foam. Air sealing is an essential step before insulation is added (Photo Source: PNNL).



More Information

Additional information on home energy upgrades and other building science information can be found in the Building America Best Practices guides produced by the U.S. Department of Energy and available for free download at www.buildingamerica.gov.

Ventilate Right

When you have sealed air leaks, you may need to add mechanical ventilation to ensure that your home has a good source of fresh air. Replacing stale air with fresh air is essential for health and comfort. Poorly ventilated homes can accumulate chemicals, gases, and moisture.

Your contractor will use ASHRAE Standard 62.2 or other industry guidelines to determine your home's ventilation needs.

Air Leakage Trouble Spots

- 1 Air Barrier and Thermal Barrier Alignment
- 2 Attic Air Sealing
- 3 Attic Kneewalls
- 4 Shafts for Piping or Ducts
- 5 Dropped Ceiling/Soffit
- 6 Staircase Framing at Exterior Wall
- 7 Porch-Wall Juncture
- 8 Flue or Chimney Shaft
- 9 Attic Hatch
- 10 Recessed Lighting
- 11 Ducts
- 12 Whole-House Fan
- 13 Exterior Wall Penetrations
- 14 Fireplace Wall
- 15 Garage/Living Space Walls
- 16 Cantilevered Floor
- 17 Rim Joists, Sill Plate, Foundation, Floor
- 18 Windows & Doors
- 19 Common Walls between Attached Dwelling Units

- **Poor air quality.** Air leaks allow dust, pollen, and mold spores to enter the house, contributing to health problems.
- **Mold and rot.** If the moisture in air condenses on organic surfaces such as wood or paper-faced drywall, it can lead to mold and rot inside the walls and in other parts of the house.
- **Discomfort.** Air leaks can cause drafts and uneven temperatures in your home.

Chimneys and the cracks around doors and windows are well-known trouble spots when it comes to air leakage, but other leaks can be more significant. Common air leakage spots are shown in Figure 5.1.

Air sealing is inexpensive and highly effective. For more information on air sealing, see Building America's Air Sealing Guide at http://apps1.eere.energy.gov/buildings/publications/pdfs/building_americal_ba_airsealing_report.pdf

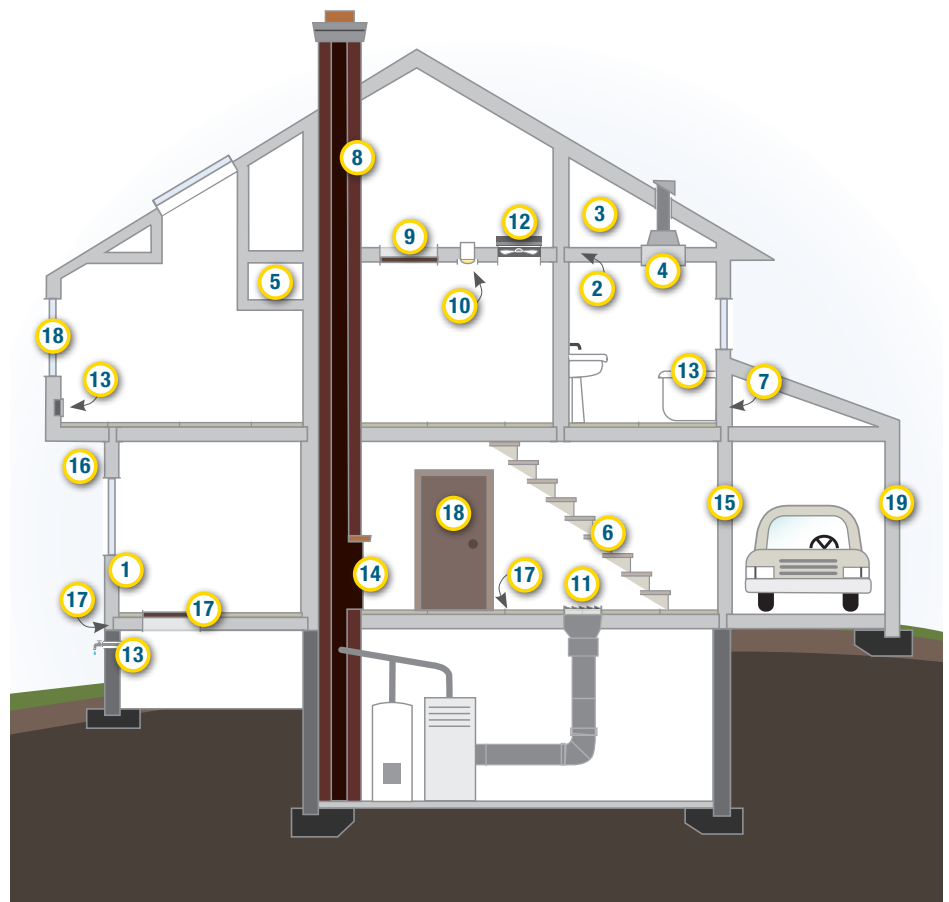


Figure 5.1. Where to air seal. Building America research has identified 19 key areas where air sealing can improve a home's energy efficiency, comfort, and durability. A certified home performance contractor can perform a home energy checkup to identify areas in your home that need air sealing (Figure Source: PNNL).

5.1 Insulating an Attic

The attic is the first place your contractor should insulate. Air-sealing and adding insulation to an attic can do more than any other insulation project to increase comfort and cut energy bills. Most attic insulation projects can be done at any time.

When you decide to add insulation to an attic, your contractor will first do some essential preparation. Installation should begin only after these steps are completed. Be sure to hire a contractor certified in building science. A knowledgeable contractor will help you decide whether a vented or unvented attic is best for your home.

This section provides guidance on the following topics:

- 5.1.1. Preparing to insulate an attic: Safety, moisture control, and ventilation
- 5.1.2. Insulating a vented attic
- 5.1.3. Insulating an unvented attic.

5.1.1 Preparing to Insulate an Attic

Before adding insulation to your attic, your contractor must:

- Address safety issues.
- Control moisture by air sealing the attic.
- Address ventilation issues.

The following is guidance for these three crucial steps.

Address Safety Issues

Resolving safety issues is the first essential step in preparing to insulate an attic. Do NOT proceed with air sealing or insulating if:

- The house has a leaking roof. Fix it to prevent moisture problems.
- Active knob-and-tube wiring is found in the attic. For fire safety, the house must be rewired first.
- An exhaust fan is vented into the attic. Bathroom, kitchen, and clothes dryer fans must be vented to the outdoors. Otherwise, fans can blow moist air into the attic, where it may condense and cause mold and wood damage.

Profile

Improving the ducts means insulating, air sealing, and proper installation too

When insulating your attic, make sure your ductwork is also properly installed, sealed, and insulated. A home in California's Central Valley had leaky ducts suspended from the attic framing. Droops and kinks in the flex ducts severely restricted air flow in the leaky ducts.

The hanging ductwork was removed. New R-8 insulated ducts were laid on trusses, the joints were sealed with mastic. A duct blaster test with the new system showed leakage of just 5.1%. The builder, Grupe, also replaced the aged, oversized furnace and air conditioner with a high-efficiency 2.5-ton furnace and 2.5-ton air conditioner that were almost half the size of the equipment they replaced.

Grupe removed old R-30 blown fiberglass in the flat attic and sagging R-22 fiberglass batts in the cathedral ceiling. They air sealed the ceiling and reinstalled the fiberglass, then added blown cellulose over it for R-49 attic insulation. The builder also replaced 14 leaky can lights with insulation contact-rated recessed lights. Whole house air leakage was cut by 55%.

(Source: DOE 2009a)

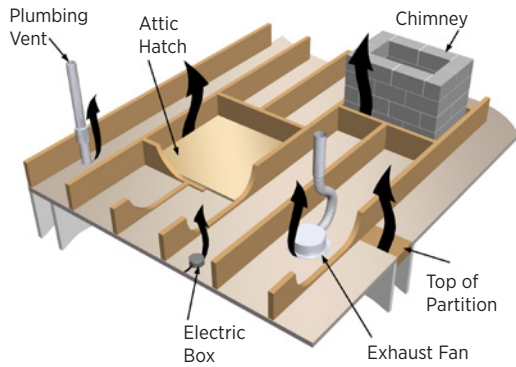


Figure 5.2. Ceiling holes. Homes are typically constructed with lots of holes in the ceiling for lights, pipes, vents, ducts, and chimneys. If the builder fails to air seal around these, air escaping through the gaps can carry moisture, possibly leading to mold and wood rot. These gaps must be air sealed before insulation is added to the attic (Figure Source: PNNL).

- The house has an unvented kerosene heater or gas fireplace. For health and safety, it must be vented or removed before you can air seal and insulate the attic.
- The attic has vermiculite insulation. Don't disturb it. It may contain asbestos. See the information on vermiculite insulation in Chapter 4 of this guide.

Control Moisture by Air Sealing the Attic

Air sealing to prevent moisture problems is the second essential step in preparing to insulate an attic. If you choose to add insulation without air sealing the attic, you risk serious moisture problems.

AIR LEAKS AND THE “STACK EFFECT” PUT MOISTURE IN THE ATTIC. Air carries both moisture and heat. Just as hot air moves up a chimney to escape through the hole above, warm air in your house rises and escapes into the attic through holes in the ceiling (Figure 5.3). This upward movement of air is called the “stack effect.”

Because of the stack effect, some of the moisture in your home—from cooking, bathing, and breathing—ends up in your attic. When moist air meets an attic surface with a temperature below the dew point, the air deposits its moisture. If the moisture condenses on organic surfaces such as wood or paper-faced drywall, it can lead to mold and rot. For further details, see Appendix B, “Air Leakage, Moisture and Ventilation: Why You Need a Whole-House Approach.”

Figure 5.3. The stack effect. The warmer air inside the home is more buoyant than the outside air. Thus it wants to rise and will push its way out of any holes in the ceiling. The flow of air out of the top of the building draws in cold air through cracks in the floor and walls of the house. Air sealing the ceiling slows down this stack effect (Figure Source: EPA).



INSULATION WITHOUT AIR SEALING CAN WORSEN MOISTURE PROBLEMS. The fiberglass and cellulose insulation typically used on an attic floor will not stop the stack effect. Air moves right through fiber insulation. This reduces its R-value. More importantly, it can make moisture problems worse. Airborne moisture can dampen the fiber insulation, increasing moisture risks. At the same time, the insulation reduces the heat entering the attic, leaving wood surfaces colder. Moisture is more likely to condense on cold surfaces, leading to mold and wood damage.

Air escaping to the attic through the stack effect also creates problems with temperature, air quality, and moisture throughout your home:

- Air you pay to heat is lost to the attic.
- Replacement air is sucked into your living space from the outdoors or from the basement or crawlspace.
- The incoming air can carry pollutants such as dust and soil gases.
- Your home’s equipment has to work harder to warm or cool the incoming air.
- The incoming air is often damp or humid. The moisture in the air may condense on cold surfaces in your crawlspace or basement and even inside your walls, leading to mold and wood damage.

AIR SEALING KEEPS INDOOR MOISTURE OUT OF THE ATTIC. Air sealing the attic floor stops the escape of air into the attic, reducing moisture problems and saving energy. Furthermore, stopping the flow of air into the attic means that outside air will not be pulled in to the rest of the house to replace it, avoiding the problems listed above.

As your energy contractor knows, it takes knowledge and skill to effectively air seal an attic floor in an existing home. It can involve pulling insulation back to seal the top plates and wire penetrations, making covers for recessed lights, cutting sheet metal to fit around flues, and trying to squeeze into areas with limited access to apply sealant – all while kneeling on top of ceiling joists and taking care not to fall between them. Some crucial areas may be impossible to reach. The low roof pitch of many homes can create a space too tight to do the crucial sealing of the top plates at the eaves. For some homes, the solution is to convert the attic to a “cathedralized” design, air sealing and insulating at the roof along the sloped roofline. This option is discussed in Section 5.1.3.



(Top) **Spray foam insulation.** Spray foam was used to simultaneously air seal and insulate this ventilated attic. Baffles installed in each rafter bay keep the insulation from blocking the soffit vents (Photo Source: WSU Energy Office).

(Bottom) **Spray foam at roofline.** Some homeowners choose to air seal and insulate the attic at the roofline, turning the attic into an unvented, conditioned space. As a result, HVAC equipment and stored items in the attic are protected from the temperature extremes typical of a vented attic (Photo Source: IBACOS).

Potential Problems with Ductwork in a Vented Attic

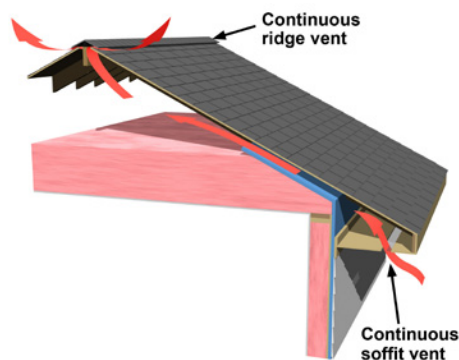
Ductwork and energy bills. If you have ductwork in a vented attic, the ducts have to run through space that can be hotter than 100°F in the summer and well below freezing in the winter. Heating or cooling the air inside the ducts will cost more, especially if the ducts are leaky.

Ductwork and safety. If you have ducts in a vented attic and live in a cold climate, leaky heating ducts can cause snow on the roof to melt, leading to ice dam formation. Ice dams are dangerous because the icicles that form with them can fall on people. The water that accumulates can leak through the roof, rot out attic framing, and collect on your ceiling; and the ice and water buildup can collapse the roof.

Ductwork and air quality. If you have ductwork in a vented attic and live in a hot, humid climate, moisture can condense on the inside and outside of ducts transporting cooled air. If mold and mildew form, the spores will be circulated through the home. Your home's air quality can also be compromised if leaky return ducts in a vented attic pull in dust and moist air.

What to do. Your contractor can minimize these problems by insulating and air sealing the ducts. Alternatively, you can convert your attic to an unvented design, or, if you are replacing your heating and cooling system, you can opt for a ductless heat pump.

Figure 5.4. Vented attics. Good ventilation helps keep an attic cool and dry. In winter, cold winter air entering through the soffit vents discourages condensation, since cold air carries much less moisture than warm air. In summer, hot, humid air can escape through the roof vents.



Make a Decision about Ventilation

The third essential step before insulating an attic is to address ventilation. Before adding insulation, your attic must have either good ventilation or no ventilation. Both options will control moisture problems and attic temperatures:

- **Good ventilation.** Outdoor air moving through the attic helps make it cool and dry.
- **No ventilation.** An unvented attic is warmer in winter, cooler in summer, and dry year-round.

The best attic type for your home depends on your climate, your roof design, your budget, and whether ductwork is in the attic. Both approaches have advantages and drawbacks, as described in the next sections.

5.1.2 Insulating a Vented Attic

It may seem odd to seal air leaks at the attic floor and then make sure plenty of air can enter through the attic vents. This combination, however, is the key to preventing moisture problems. The air sealing at the attic floor blocks the entry of moist air from the living space. The ventilation along the roofline cools the attic and allows humid air to escape. In winter, cold air entering through the soffit vents discourages condensation, since cold air carries much less moisture than warm air. In summer, hot, humid air escapes through the roof vents (Figure 5.4).

With good ventilation, air sealing, and insulation, a vented attic can help make your home comfortable, durable, and energy efficient.

Advantages and Drawbacks of Vented Attics

A Vented Attic has Advantages in terms of:

- **Climate.** A well-ventilated and insulated attic works well in any climate, provided the attic floor and attic entryway are air-tight.
- **Cost.** The least expensive types of insulation, loose-fill fiber and fiberglass batts, are good choices for insulating the floor of a vented attic.

A Vented Attic may have Drawbacks in terms of:

- **Ductwork.** Ductwork in a vented attic can increase energy bills and compromise air quality (see sidebar).
- **Roof design.** If your home does not have a simple gable roof, good ventilation can be difficult to achieve. Because ventilation requires

a direct path from the soffit to the ridge, complex roofs typically have ventilation problems. Features such as valleys, hips, skylights, and multiple dormers can make attics difficult to ventilate effectively and to air seal and insulate well at the ceiling level (Lstiburek 2006c). Conversion to an unvented attic may be called for if you have a complex roof design.

A Poorly Ventilated Attic may have Problems with:

- **Ice dams.** Warm air can collect in the attic when it is poorly ventilated and lacks air sealing at the floor. (See Appendix C for a performance brief on preventing ice dams.)
- **Mold, mildew, and wood rot in winter.** Moist air trapped in a poorly ventilated attic can condense on cold surfaces.
- **Mold and mildew in summer.** In hot, humid climates, moisture in a poorly ventilated attic can condense on both the inside and outside of ducts that are transporting cooled air.
- **Energy efficiency.** In a home with a poorly ventilated attic, heat in summer and the stack effect in winter will require more heating and air conditioning, especially if ductwork is in the attic.

To Improve Ventilation, your Contractor Should:

- Make sure your home has adequate vent space at the soffits and roof. For details, see the sidebar titled “How much attic ventilation do you need?”
- Make sure the soffit vents are not clogged, painted over, or blocked by insulation.
- In hurricane-prone areas, install special soffit vents that keep out wind-blown rain (see performance brief in Appendix C.)

If these measures do not solve moisture problems, consider converting your attic to an unvented design.

Your Contractor Should NOT Install Powered Roof Ventilation

Building America scientists do not recommend installing a powered roof fan to improve attic ventilation, because:

- Powered roof fans consume more energy than they save.
- They increase the stack effect, which pulls hot, humid outside air into the home and can pull in pollutants from the basement or crawlspace.
- They can cause backdrafting of fireplaces and unsealed gas- or oil-burning appliances (DOE 2000b; Katz 2011).

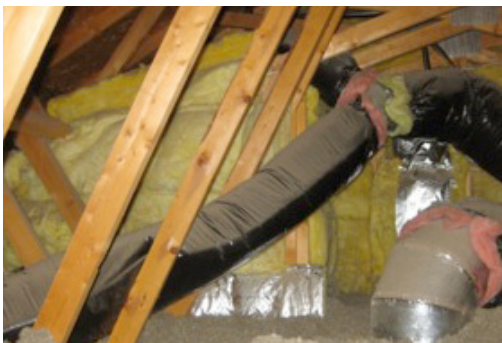


Ice dams. Ice dams occur when the outside air is below freezing but the roof surface is above freezing. The roof surface may be warmed by the sun, by leaky heating ducts in the attic, or by warm air leaking into the attic from the living space below. Icicles are a telltale sign that ice dams are forming on your roof. Snow melts on the roof and then refreezes along the roof’s edge, forming an icy buildup. As more snow melts, some will spill over and drip down the edge of the roof, forming icicles. The rest will collect behind the ice dam. The water in the ice dam may eventually back up between the roof shingles and into the attic, causing moisture damage. It can also pool on the roof until it causes the roof to collapse (Source: BSC).

How much attic ventilation do you need?

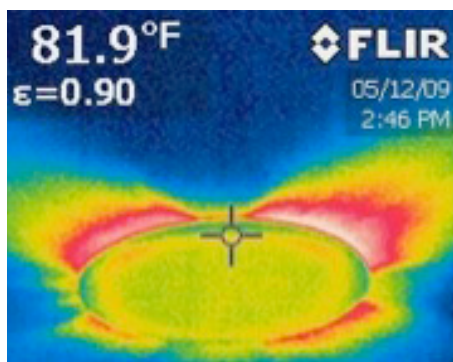
A rule of thumb is to have 1 square foot of net vent opening for every 150 square feet of insulated ceiling. The most effective ventilation system combines a continuous ridge vent along the peak of the roof with continuous soffit vents at the eaves, but few existing homes are built that way (DOE 2000b). The vent area is typically divided 50:50 between the soffits and ridge, but a Building America scientist recommends a larger vent area for the soffits—a ratio of about 60:40 (Lstiburek 2011a).

Lstiburek also calls for more ventilation than codes typically require, especially in areas with snow. He recommends a minimum airspace under the roof sheathing of 2 inches, not the typical 1 inch, and recommends that every rafter or truss bay, not every third one, be ventilated (Lstiburek 2011b).



(Top) **Loose-fill fiberglass.** In this Connecticut home, blown fiberglass insulation completely covers the ceiling joists of the attic floor, insulating it to R-50 (Photo Source: BSC).

(Bottom) **Sloppy batt installation.** The wall between the hot attic space and an upstairs bedroom had thick fiberglass batts. However, instead of putting the batts in the stud cavities, the installer had attached them to the front of the studs, leaving a gap behind the batts for hot air to reach the wall. The bedroom was hot in summer, despite air conditioning (Photo Source: PNNL).



Air leakage around recessed light.

As shown in this image taken with an infrared camera, hot attic air can leak into a home around a recessed can light in summer. In winter, warm, conditioned air can be pulled out of the house and into the attic.

How to Insulate a Vented Attic

Your contractor should begin insulating your vented attic only after the following steps are completed (for details, see Section 5.1.1, above):

1. All safety issues are resolved.
2. The attic floor is thoroughly air-sealed.
3. Good ventilation is ensured.

This section provides guidance for insulating a vented attic. It includes information on preparing to insulate, installing batt insulation, installing loose-fill insulation, and using spray foam to insulate the attic perimeter.

Appendix C provides performance briefs with instructions for air sealing and insulating specific areas of a vented attic, as listed below:

- Attic kneewalls
- Attic hatches, doors, and drop-down stairs
- Around recessed “can” lights
- Around chimneys or flue pipes
- Around ducts and duct shafts.

Preparing to Insulate a Vented Attic

Your first step is to decide on a type of insulation. Typical forms of insulation are:

- Batts or blankets, most often made of fiberglass. Alternative materials include mineral wool, sheep’s wool, and cotton.
- Loose-fill, blown-in fiber, typically cellulose or fiberglass.

Loose-fill fiber insulation usually costs less than batts and provides better coverage, because it conforms to the space into which it is blown. The small fiber particles fill spaces behind and around obstacles, where it’s difficult to install batt insulation. See the tables in Chapter 3 for other advantages and drawbacks of the insulation types.

You can choose to put different forms of insulation together. For example, your contractor can add blown insulation over batt insulation. Note that material of higher density (weight per unit volume) should not be placed on top of lower-density insulation that is easily compressed. Doing so will reduce its R-value.

For either batt or blown insulation, your contractor will have two goals: to gain enough R-value and to achieve that R-value uniformly across the attic, leaving no place where insulation is missing or too shallow. Your contractor will begin with the following:

1. Look into your attic to see what kind of insulation you already have and measure its depth. (If you are doing this step yourself, a table in Chapter 2 will help you identify the insulation. If you think you have vermiculite insulation, don't disturb it; it may contain asbestos. See Chapter 4.)
2. Use tables like those in Chapter 2 to estimate the R-value of the current insulation and determine how much insulation should be added to reach the recommended R-value for your climate zone.
3. Install vent baffles to ensure that outside air can move directly from the soffits to the ridge vents (Figure 5.5).

Using Spray Foam to Insulate the Attic Perimeter

Uniform R-value across the attic floor is difficult to achieve. In a typical attic, the rafters meet the floor at a tight angle that allows for little insulation. As a result, recommended R-values often cannot be reached with fiber insulation at attic perimeters.

To solve this problem, your contractor may suggest using spray foam to insulate around the perimeter. Spray foam has a high R-value per inch and also provides excellent air sealing. Before using this method, your contractor should make sure vent baffles are installed in each rafter bay. The baffles should extend to the outside edge of the top plate and maintain a 2-inch airspace under the sheathing. This will ensure adequate air flow from the soffit vents to the ridge vents.

Installing Batt Insulation

Faced or unfaced batts? Batt facings are vapor retarders; they should be used in some climates but not others. Your contractor should:

- Install faced batts in IECC Climate Zones 5 and 6, with the facing against the attic floor. Note: If you are putting additional insulation on top of fiberglass batts, there should be no facing between the layers. If you already have faced batts on your attic floor with the facing on top, do not put insulation over them. Facing between the layers can act as a vapor retarder and create problems with moisture and mold.
- Use unfaced batts in IECC Climate Zones 1 through 4. Building America scientists do NOT recommend installing vapor retarders in vented attics in these zones (Lstiburek 2006c).

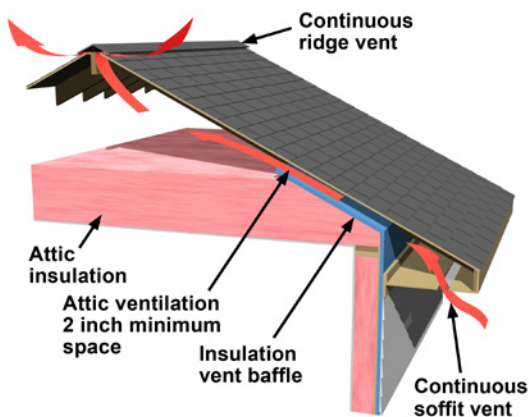


Insulated attic kneewall. The kneewall in this vented attic has been properly air sealed and insulated. Rigid foam insulation was installed in the open cavities under the kneewall (top), and then the kneewall and attic floor were insulated (bottom). Another option would be to air seal and insulate along the underside of the roofline to the eaves. This could be accomplished by continuing the attic room ceiling insulation and drywall to the eaves or installing rigid foam above the kneewall to the eaves. This would provide conditioned storage space outside the attic room, and there would be no need to insulate the kneewall.

Spray foam at the roof eaves. Spray foam can provide both air sealing and insulation in the hard-to-reach areas at the roof eaves. Baffles keep the insulation from blocking the soffit vents.



Figure 5.5. Baffles. Your contractor will install vent baffles to maintain a 2-inch continuous ventilation channel above the insulation.



If you have no existing insulation on the attic floor, your contractor should:

- Measure and cut the batts to fit perfectly in each cavity and extend to the very edge of the attic floor.
- Roll out the batts between the joists, making sure the batts are in full contact with all floor and cavity surfaces. Even small gaps add up to a large reduction in effective R-Value; they are like holes in a blanket.
- Cut the batts carefully to fit around pipes, ducts and wires, without any pinching or compression.
- Place a second layer of insulation over the tops of the joists to reduce thermal bridging (heat loss through the wood). This second layer can be blown loose-fill insulation or a second layer of batts laid perpendicular to the joists.

If you already have existing insulation that has no gaps and that fills the cavities to the tops of the joists:

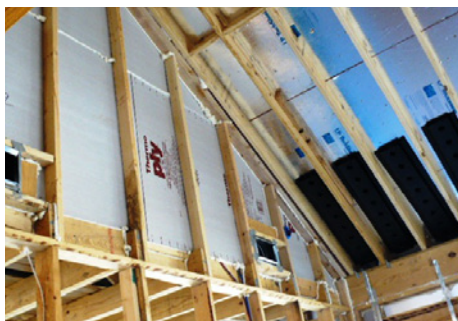
- Your contractor should place the new batts perpendicular to the old ones, covering the tops of the joists; or cover the joists or old batts with blown insulation.

Installing Loose-Fill Insulation

Loose-fill fiber insulation is blown into the attic with a pneumatic hose. It is usually installed by a professional installer, who will:

- Install vent baffles to keep blown insulation out of the soffit vents.
- Staple rulers to floor joists in different parts of the attic to measure the depth of the insulation as it is blown in.
- Blow insulation across the entire attic floor, at an even depth.
- Blow enough insulation to achieve the manufacturer's recommended density. If the density is too low (known in the trade as “fluffing”), the insulation will settle excessively and have a lower R-value.

Radiant barrier. While it doesn't add R-value, a radiant barrier can reduce cooling loads in hot climates by minimizing solar heat gain. A radiant barrier looks like aluminum foil and has a backing of bubble wrap, paper, or sheathing. They can be stapled to the underside of the roof rafters. Or, when reroofing, sheathing can be installed that comes with a radiant barrier layer adhered to it, as shown here (Photo Source: David Weekley Homes).



Radiant Barriers for Vented Attics

If you live in a hot-dry or hot-humid climate, it may be cost-effective to install a radiant barrier in your vented attic along with the insulation. A radiant barrier is basically aluminum foil that comes with a variety of backings. It reduces the amount of heat that moves from your roof to the attic floor. Radiant barriers are appropriate only for vented – not unvented – attics (Lstiburek 2010b). For instructions on installing radiant barriers, see Appendix C.

5.1.3 Insulating Unvented Attics

An unvented attic is air sealed and insulated at the sloped roofline instead of on the floor. When you convert your attic to an unvented design, it becomes indoor space, similar to a room with a cathedral ceiling.

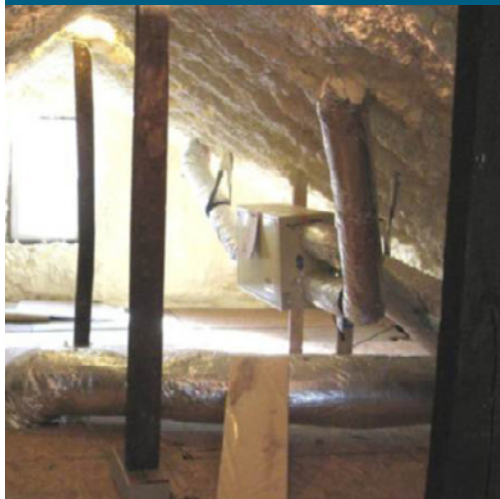
Advantages and Drawbacks of Unvented, Insulated Attics

An Unvented, Insulated Attic has Advantages in terms of:

- **Energy efficiency when ducts are in attic.** An unvented attic is warmer in winter and cooler in summer. Ductwork that is not subject to extreme temperatures will last longer and be more efficient (DOE 2003).
- **Energy efficiency in hot climates.** Homes with an unvented attic in the hot-dry or hot-humid climate zones typically use less energy (DOE 2003, Rudd et al. 1999).
- **Avoiding moisture problems.** Moist air will stay outside the attic, provided the attic ceiling is thoroughly air sealed. This is especially an advantage for homes in hot, humid climates with ductwork in the attic (Rudd et al. 1999).
- **Roof design.** An unvented attic can be a good solution for complex roofs that are hard to ventilate well.
- **Space.** An unvented attic can easily serve as living or storage space.
- **Weather resistance.** Roofs over unvented attics are less likely to be blown off in high winds. In wildfire zones, a house without soffit vents is less like to catch fire. In coastal areas, an unvented roof keeps out wind-driven rain, and metal pieces in the roof assembly are protected against salt spray and corrosion (Lstiburek 2006c).

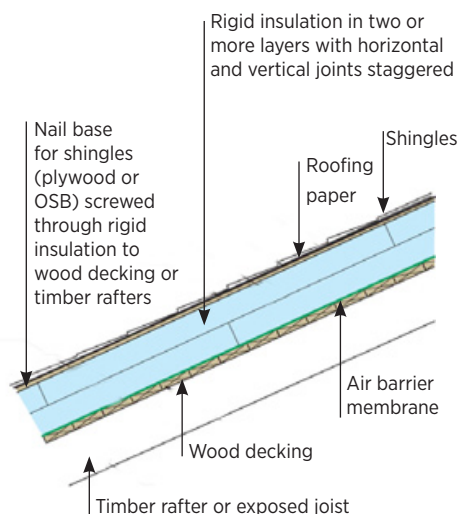
An Unvented Attic has Drawbacks in terms of:

- **Cost.** In cold or humid climates, unvented attics should be insulated with rigid or spray foam insulation, which is much more expensive than fiberglass batts or blown fiber. However, it may be cost-effective to seal and insulate an attic along the roofline when you are reroofing or creating an attic room.
- **Maintenance.** If you install exterior rigid foam insulation, it may be harder to locate roof leaks or repair rotten roof sheathing. Damp roof sheathing may take longer to dry.



Unvented attic. This attic has been sealed and insulated with spray foam insulation applied under the roof deck. This turns the attic into a conditioned space for HVAC equipment (Photo Source: W. Hawthorne).

Figure 5.6. Rigid insulation above Roof Deck. If you are reroofing your home, another way to insulate a sealed attic is with rigid insulation applied above the roof deck, as shown here (Source: BSC).



- **Roof durability.** The temperature of shingles over unvented attics is higher, reducing their durability. Homeowners can expect a 10% decrease in the service life of the roof (Lstiburek 2006c).
- **Ice dams where snow is thick.** An unvented attic increases the possibility of ice dams in areas with heavy snow loads (in excess of 50 lb/ft²). When sealing and insulating an attic in these areas, your roofer can minimize the risk by creating a vented air space between the shingles and the rigid insulation (Lstiburek 2011b).
- **Wider fascia.** Rigid insulation above the roof deck results in a wider fascia board at the eave or top of the wall.

Your contractor can determine whether your attic has adequate ventilation. If you can ventilate your attic well and it has no moisture problems, your best option may be to leave it vented. On the other hand, if your attic cannot be well ventilated and develops moisture problems, sealing and insulating it (converting it to an unvented design) may be your best option. The following sections provide guidance for insulating both types of attics.

How to Insulate an Unvented Attic

This section provides guidance for the following steps:

1. Deciding where and how to insulate.
2. Preparing the attic and closing the vents.
3. Installing insulation below the rafters.
4. Installing insulation above the rafters.

Deciding Where and How to Insulate

In the hot-dry climate zone, you can insulate an unvented attic along the underside of the roof deck by fastening netting to the rafters and filling the space between the netting and the roof deck with blown cellulose or fiberglass. However, in all other climates, insulating the underside of the roof deck with fiber insulation could lead to moisture problems (Straube and Grin 2010). To prevent condensation under the roof deck:

- Use rigid foam insulation above the roof deck to keep its temperature above 45°F throughout the year. Rigid foam can be installed if you are reroofing your house (Figure 5.6).
- Use spray foam insulation under the roof deck to keep interior moist air from contacting it.
- Supplemental insulation can be installed with either approach when additional R-value is needed.

Preparing the Attic and Closing the Vents

Your contractor should complete the following preparatory steps:

- Resolve all safety issues (see Section 5.1.1).
- Have a local code official review your unvented attic design. Code requirements for unvented attics vary significantly across the country. 2009 IRC R806.4 lists requirements for unvented attic assemblies.
- Remove the old floor insulation. This will allow the living space below to indirectly condition the attic. (It will also let workers see where they are stepping.) Loose-fill insulation can be vacuumed out by an insulation professional. Batts need to be removed by hand. If you choose to do this job yourself, wear a dust mask and gloves.
- If there is a vapor retarder on the attic floor, it must be removed. Any moisture that builds up in an unvented attic needs to diffuse into the house below. Vapor retarders on the floors of unvented attics are prohibited under the 2009 IRC.
- Close off and seal all the openings that exist to ventilate your attic, including ridge vents, gable vents, and soffit vents.
- Reroof the previously open areas.
- Seal all wood-to-wood joints in the framing.
- Remove or disable any attic fan. Take particular care, however, not to block, remove, or disable the kitchen or bathroom exhaust stacks or the exhaust vents for water heaters or furnaces, radon vent stacks, or plumbing stacks.

Building America scientists provide the following cautions:

- Do not install sheet polyethylene as an air barrier at the underside of the roof deck because of the difficulty of making it perfectly airtight. Airborne moisture can become trapped behind it (Straube 2006). Sheet polyethylene is a Class I vapor retarder and is prohibited in unvented attics under the 2009 IRC. See Appendix B.4 for important distinctions between classes of vapor retarders.
- Make sure plans do not include the installation of recessed “can” lights in the attic ceiling, even ones that are ICAT-rated. There will be no room for insulation above them, and energy will be lost through the void. Worse, they create a risk of moisture problems. Recessed lights can draw warm moist air through the ceiling and into the insulation, even when they are designed to be airtight. Track lighting is a good alternative.



Moldy fiberglass batts. The fiberglass insulation in this unvented cathedral ceiling absorbed moisture, leading to mold and wood damage. Building America scientists do not recommend using fiberglass or cellulose in a cathedral ceiling or flat roof, unless rigid or spray foam insulation is installed above the fiber to form an air and moisture barrier (Photo source: BSC).



Attic room. This attic was insulated with spray foam at the roofline to provide additional conditioned living space in the home.

Installing Insulation Under the Roof Deck of an Unvented Attic

If you live in the hot-dry climate zone, you can insulate under the roof deck with fiberglass batts or netted cellulose insulation.

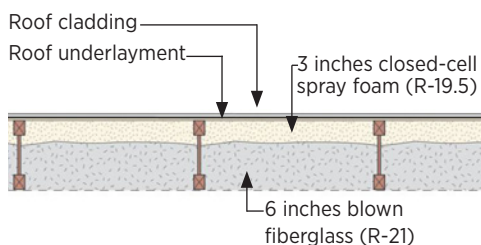
As noted previously, fiber insulation should not be placed in contact with the roof deck anywhere outside the hot-dry climate zone. Instead, spray foam insulation should be applied under the roof deck. Spray foam not only insulates but provides a tight air seal, protecting the roof deck from airborne vapor (Figure 5.7).

Two types of spray foam insulation are available, open-cell and closed-cell. Open-cell foam costs less than closed-cell foam, but has a lower R-value per inch. Both will provide a good air barrier. Closed-cell spray foam is also a vapor retarder, an advantage in cold climates that require more protection from condensation. Open-cell foam is not a vapor retarder. (See vapor retarder discussion in Section 3.2 and Appendix B.4.)

If you choose to insulate the entire ceiling cavity with spray foam, Building America scientists make the following research-based recommendations (Straube 2006):

- In IECC Climate Zones 1 through 3, open-cell foam can be used, provided interior humidity is not high (see IECC map Chapter 2).
- In Zones 4 and 5, use closed-cell foam or open cell-foam with a spray-applied vapor retarding paint on the interior side (2009 IRC Section R806.4).
- In Zones 6 and higher, closed-cell foam should be used.
- All foam on the interior should be separated from lining space by a fire-rated material, such as ½-inch gypsum board.

Figure 5.7. Closed-cell spray foam provides an air barrier to keep vapor from condensing on the underside of the unvented roof. The spray foam is supplemented with blown fiberglass between the spray foam and drywall for additional R-value (Figure Source: adapted from Straube and Grin 2010).



Supplementing Spray Foam Insulation with Fiber Insulation

In cold climates, applying enough spray foam insulation on the underside of the roof deck to reach the recommended R-value may be expensive. To reduce costs, your contractor can add inexpensive fiberglass batts, netted fiberglass, or dense-pack cellulose on the attic side of the closed-cell foam.

If you choose to supplement closed-cell spray foam with fiber insulation, Building America scientists make the following research-based recommendations (Straube and Grin 2010).

- Zones 1 through 4: Install 3 inches of closed-cell spray foam plus fiber insulation.
- Zones 5 and 6: Install 4 inches of closed-cell spray foam plus fiber insulation. This approach can also be used in Zone 7, provided interior humidity is not high
- Zones 5 through 8 and Marine Zone 4 require a Class II vapor retarder in direct contact with the underside (the attic side) of the fiber (Building Energy Codes Resource Center 2011a). Options include latex-painted gypsum board or a kraft facing on fiberglass batts.

Installing Insulation above the Roof Deck of an Unvented Attic

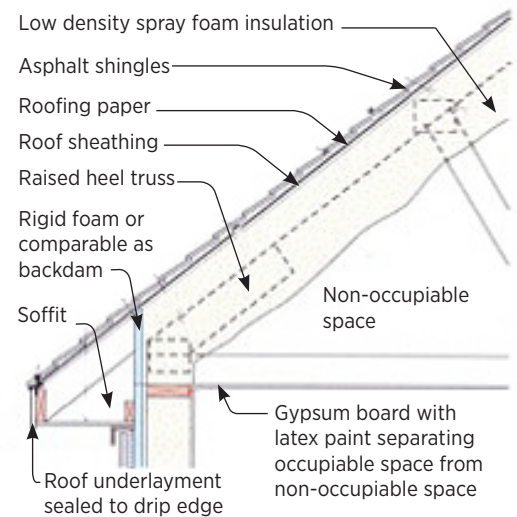
Reroofing your house creates an opportunity to add insulation above the roof deck. Your roofer can install sheets of rigid foam insulation between the roof shingles and the roof plywood or OSB (Figures 5.6 and 5.9). Alternatively, your roofer can install sheathing bonded with rigid foam or structural insulated panels designed for roofs.

Your contractor will follow the manufacturer's installation instructions. Building America scientists add the following research-based cautions and recommendations.

- Your roofer must make the roof deck exceptionally airtight. This can be done by placing the rigid foam between two layers of OSB and covering the lower OSB layer with a continuous, lapped peel-and-stick membrane.
- To prevent air leaks, seams and edges at the eaves must be carefully sealed.
- With wood shingles or shakes, a ¼-inch air space must separate the shingles or shakes from the roofing felt over the structural sheathing (DOE 2007a; Lstiburek 2004c).
- With asphalt roofing shingles in the hot-humid, mixed-humid, and marine climate zones, a Class II vapor retarder should be installed under the shingles for moisture control (Lstiburek 2004c).
- When using sheets of rigid foam, install two layers of rigid foam (e.g., two 3-inch layers instead of one 6-inch layer) and stagger the seams.
- Apply latex primer to the gypsum board ceiling to serve as a vapor retarder (Straube and Grin 2010) before painting or texturing.

Figure 5.8. Spray foam in an unvented attic.

In this configuration, low-density, open-cell spray foam is used to insulate an unvented attic. This configuration is appropriate for hot climate zones. For unvented attics in mixed climate zones, use closed-cell foam or open-cell foam covered by a vapor retarder. In cold climates, vapor-retarding closed-cell spray foam should be used (Figure Source: Straube and Grin 2010).



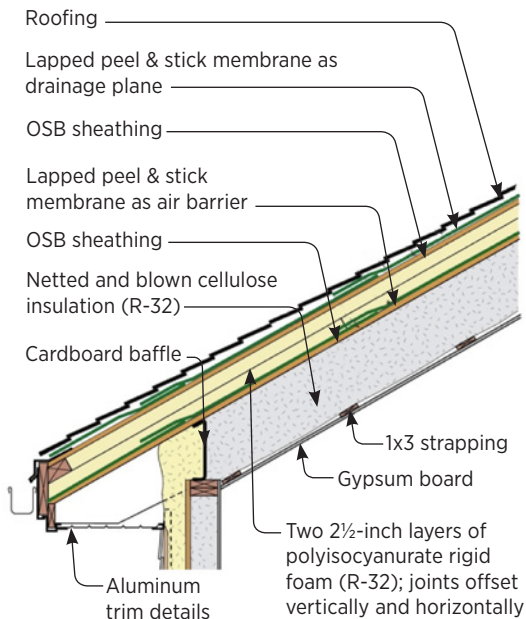
To identify your climate zone, see the map in Chapter 2.

Air seal and insulate. Spray foam was combined with unfaced batt insulation in this garage ceiling to get the air sealing value of the spray foam and the added R-value of the less expensive batt insulation (Photo Source: BSC).



Figure 5.9. Unvented attic.

In this configuration for insulating an unvented attic, rigid foam insulation is sandwiched between two layers of OSB sheathing. The lower layer of OSB is covered with a lapped peel-and-stick membrane, which provides an air and moisture barrier at the roof line. The upper layer of OSB serves as the roof deck and supports the roofing material. This OSB layer is covered with peel and stick membrane, which serves as a drainage plane. Blown or batt insulation can be installed between the roof deck and the ceiling gypsum to provide additional R-value (Figure Source: Straube and Grin 2010).



Supplementing Rigid Foam Insulation with Fiber Insulation

In cold climates, it may not be practical to install enough rigid foam insulation above the roof deck to achieve the recommended R-value. To supplement the rigid foam, spray foam insulation can be added under the roof deck. Alternatively, inexpensive fiberglass batts or netted cellulose can be installed under the roof deck. However, placing fiber insulation against the roof deck requires careful measures to reduce the risk of moisture problems. In addition to the recommendations above, Building America research shows the following must be done:

- The rigid foam above the roof deck must provide a certain proportion of the overall R-value (Straube and Grin 2010). The proportion depends on your climate zone (Table 5.1). For example, if you are in Climate Zone 5, your contractor should install rigid foam of at least R-20. It can then be supplemented with enough fiber insulation to achieve the goal of R-38.
- In Climate Zones 5 through 8, a vapor retarder must be installed in direct contact with the fiber insulation (Building Energy Codes Resource Center 2011a).

Table 5.1. Insulation Proportions for Condensation Control

When combining rigid foam over the roof deck with fiber insulation under the roof deck, the two types of insulation must be in correct proportion. The proportion depends on your climate.

Climate Zone	Install rigid foam insulation over roof deck with an R-value of at least:	Add fiber insulation under roof deck to reach these R-values recommended by the IECC:
2B and 3B tile roof only	0 (none required)	R-30
1, 2A, 2B, 3	R-5	R-30
4C	R-10	R-30
4A, 4B	R-15	R-38
5	R-20	R-38
6	R-25	R-49
7	R-30	R-49

Source: Straube and Grin 2010: 2009 IRC Unvented Attics Table 806.4 with IECC R-values

5.2 Insulating Flat Roofs and Vaulted Ceilings

Insulating a flat roof or vaulted ceiling (also called a cathedral ceiling) is challenging. The narrow cavity above the ceiling makes it difficult to add enough insulation and the constrained air flow hinders moisture diffusion.

Insulating a flat roof or vaulted ceiling is generally done as part of a reroofing project or indoor remodeling project. Gaining access to the ceiling cavity requires removal of either the ceiling or the roof, and removal of any existing insulation.

This section provides guidance for insulating a vented flat roof or vaulted ceiling. If you are insulating an unvented space, follow the instructions in Section 5.1.3, “How to Insulate an Unvented, ‘Cathedralized’ Attic.”

Insulating a Vented Flat Roof or Vaulted Ceiling

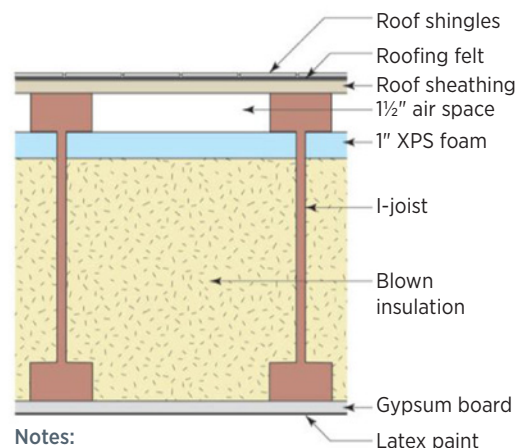
A vented flat roof or vaulted ceiling requires a continuous ventilation space under the roof sheathing to prevent moisture problems:

- Vented flat roofs require a continuous 1½-inch air space between the roof sheathing and the top of the insulation (Figure 5.10). This air space is the critical factor in controlling moisture accumulation in the sheathing.
- Vaulted ceilings require the same continuous 1½-inch air space from soffit vents to ridge vents. Note: This direct path for ventilation is possible only in a house with a rectangular plan, a simple gable roof, and no dormers. If this does not describe your house, effective moisture control requires conversion to an unvented design (Straube and Grin 2010). Follow the guidance in Section 5.1.3.

Building America scientists recommend insulating a vented flat roof or vaulted ceiling with moisture-resistant XPS (extruded polystyrene) rigid foam:

- Install 1-inch-thick pieces of XPS, leaving a 1½-inch air space between the XPS and the roof sheathing. For additional R-value, add extra layers of XPS or supplement it with dense-pack cellulose in the space left between the XPS and the ceiling gypsum board, as shown in Figure 5.10.

Figure 5.10. Vented flat roof. When insulating a vented flat roof or vented vaulted ceiling, a 1½-inch air space is required over XPS foam insulation. The joist cavities below the rigid foam are filled with blown fiber insulation for additional R-value (Source: Straube and Grin 2010).

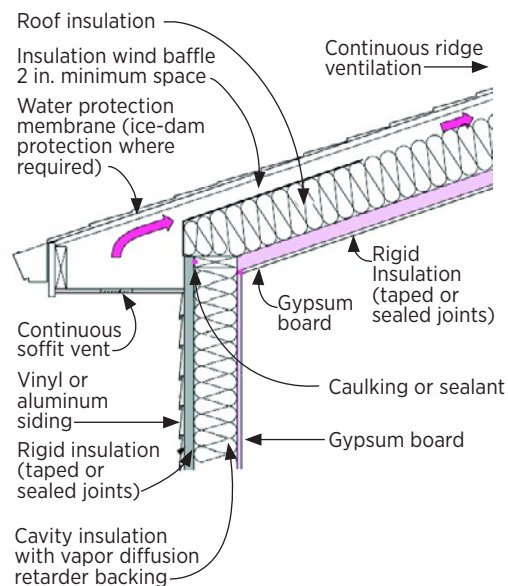


Notes:

- 1½" vented air space connected to soffit and ridge vents
- Gypsum board as air barrier
- Use care at recessed fixtures
- Latex paint as primary vapor retarder

Figure 5.11. Vented cathedral ceiling.

Rigid insulation can be added to a vented cathedral ceiling to provide additional R-value. It is important to provide a continuous air barrier to prevent moisture-laden air from getting into the attic by taping at seams and sealing at the edges. A continuous air barrier is difficult to achieve if the ceiling contains recessed lighting fixtures or other ceiling penetrations (Source: Straube and Grin 2010).



Profile

Spray Foam Insulates Las Vegas Ceiling

The builder wanted to cut energy use and retain this 1963 Las Vegas home's Mid Century Modern styling so he worked with Building America on a plan that included gutting walls, replacing windows, and taking off the old roof to expose cathedral ceiling cavities that were then filled with 8 inches of closed-cell spray foam. The foam was topped with OSB, water-proofing membrane, and two perpendicular layers of 1x3 wood spacers to allow venting under the "cool" white metal roof. These and other measures cut the ReVision home's energy use 60%.



Closed-cell spray foam fills the rafter bays of the vented cathedral ceiling.



This 1963 Las Vegas home got new insulation, windows, and a new roof to cut energy use by 60%.

- Make sure the ceiling gypsum board is thoroughly air sealed with caulk, mud, and tape, and then apply latex paint as a vapor retarder.

Building America scientists do NOT recommend installing fiberglass or cellulose insulation in vented flat or vaulted ceilings without XPS rigid foam separating the fiber from the air space. Otherwise, air will blow through the fiber insulation, leading to mold and rot (Lstiburek 2010a).

Recessed "can" lights should never be installed in a vaulted ceiling or under a flat roof, even if they are ICAT-rated. There is no room for insulation above them, and energy will be lost through the void. Worse, they create a risk of moisture problems. Recessed lights can draw warm moist air through the ceiling and into the insulation, even when they are designed to be airtight. Any recessed lights already installed must be removed, and the holes carefully repaired and sealed.

5.3 Insulating Exterior Walls

This section provides general guidance for most wall insulation projects. A knowledgeable contractor can help you choose the best insulation for your project and plan strategies to control moisture.

Decisions about wall insulation depend on whether your home has non-masonry stud-framed walls sided with wood, vinyl, aluminum, or fiber cement or masonry walls of brick, stone, or concrete.

5.3.1 Stud-Framed Walls: When to Insulate

Stud-framed walls with wood, vinyl, aluminum, or fiber cement siding can be insulated with a variety of products. Loose batts can be added to the interior of the walls within the stud cavities. Rigid foam insulation can be attached to the interior side of the walls or to the exterior, under the siding. Each approach has advantages and drawbacks.

Projects for insulating non-masonry, stud-framed walls fall into three categories: those you can do any time, those you can do when replacing your siding, and those you can do when a wall is gutted on the inside for a remodeling project.

Adding Insulation at any Time

- **“Drill and fill.”** Your contractor will drill holes into each stud cavity from the interior or exterior and then blow in cellulose or loose fiberglass insulation.
- **Cantilever insulation.** A cantilevered floor, such as a bump-out, bay window, or room over an open porch may not be air sealed and insulated. You can correct this at any time. For details, see the performance brief in Appendix C.

Adding Insulation when Replacing your Siding

- **Exterior rigid insulation.** Highly effective rigid foam insulation can be installed over the existing sheathing or in place of it.
- **Proprietary insulation systems.** You can install rigid foam blocks under new siding, or replace your siding with insulated vinyl siding or a stucco-like exterior insulation finish system (EIFS).
- **“Drill and fill” through the sheathing.** Holes can be drilled through the existing sheathing to blow dense-pack fiber insulation into the stud cavities.
- **Replacing exterior wall surfaces.** If the siding project includes removal of the sheathing, the open wall cavities can be filled with batt, blown, or spray foam insulation.

Adding Insulation when Remodeling

- **Cavity insulation.** If a wall is gutted, it will be inexpensive to fill the open wall cavities with fiberglass or cellulose insulation. Alternatively, you can fill the cavities with spray foam insulation or attach rigid foam insulation to the exposed studs. The foam products are much more expensive but provide superior air sealing and moisture resistance.
- **Bathroom remodeling.** If your shower stall or bathtub is removed, you may find there is no insulation or air barrier in the exterior wall behind it. For details on air sealing and insulating this space, see Appendix C.
- **Replacing a fireplace insert or rebuilding a chimney.** You may find that the stove or fireplace was installed with no insulation or air barrier in the exterior wall behind it. For details on air sealing and insulating this space, see Appendix C.



Opportunity to insulate. The siding needed to be replaced in this major renovation of an uninsulated Sacramento home. Removing the siding created an opportunity to add rigid foam insulation to the exterior of the walls (Photo source: SMUD).

See Appendix C for performance briefs on

- Insulating cantilevers
- Air sealing and insulating behind tubs and showers
- Air sealing and insulating around fireplaces.

Profile



Rotting wood. Hidden under the vinyl siding was the home's original wood siding, which was moldy and rotten. A poorly designed wall assembly had allowed water to penetrate for years.



Exterior insulation. Workers installed a continuous air barrier on the above-grade portions of the house, including the roof, then wrapped it again with continuous layers of insulation.



Air barrier. The new wall assembly has foil-faced rigid foam sheathing, carefully taped to provide a continuous air barrier. Furring strips in front of the foam create an air space for proper drainage.

Source: BSC 2011

1953 Home Held a Rotten Surprise

After 25 years of improving the interior, the Massachusetts homeowners were ready to work on energy efficiency and exterior upgrades. Plans included exterior rigid foam insulation under new siding and a new roof, high-performance windows, and basement insulation. The National Grid Deep Energy Retrofit Pilot provided financial incentives, and Building Science Corporation, a Building America team member, provided technical support.

The project came to a sudden stop when workers removed the existing vinyl siding and discovered rotting wood shingles beneath them. They removed the shingles and tar paper and found extensive water damage. Molded and rotten sections of the wood sheathing, wall studs, mud sill and a window header had to be torn out.

The roof was the source of the problem. The home had been built with no roof overhangs, putting the roof gutters in the same plane as the walls. Whenever gutters leaked or overflowed, water coursed down the walls. Some of it seeped through the vinyl siding. Without an adequate air cavity and drainage plane between the vinyl and the wood shingles, the water penetrated the shingles and the tar paper and soaked into the wood framing. Melting water from ice dams also made its way into the walls.

The water-damaged framing and sheathing were replaced, and the upgrade work continued. Workers wrapped the above-grade walls with house wrap, applied shingle-style over the wood sheathing, with seams and edges taped. A self-adhering roofing membrane was overlapped onto the house wrap to create a continuous air barrier. Two 2-inch layers of foil-faced polyisocyanurate rigid foam insulation were attached over the roof and walls. The owner commented that the house looked like a box wrapped in "a blanket of insulation."

Eave and rake overhangs were added before the new roof was installed – a major improvement in water management. In the sealed attic, the rafter bays were filled with spray foam insulation. Together with the rigid foam above, this created an R-60 roof.

With batt insulation in the wall cavities and the rigid foam outside, the new wall assemblies are R-40. The upgrade served the homeowners by exposing the water damage. Now the home is durable as well as comfortable and energy-efficient.

5.3.2 Stud-Framed Walls: Adding Interior Cavity Insulation

The most common insulations used to fill wall cavities are fiberglass batts, loose-fill fiber (cellulose or fiberglass), and spray foam.

Cavity insulation will improve your home's energy efficiency, but it has limitations. The R-value attained with cavity insulation is limited by the depth of the stud cavities and by thermal bridging. Thermal bridging is the loss of heat through the wood studs, which can reduce the R-value of the wall assembly by 25% to 40% (Straube 2011). Every stud marks the absence of insulation.

This section provides guidance on the following approaches to adding insulation to non-masonry walls :

- Adding insulation to a closed wall with “drill and fill”
- Adding fiber insulation to open wall cavities
- Adding spray foam insulation to open wall cavities
- Attaching rigid foam to the interior of a non-masonry wall.

Adding Insulation to a Closed Wall with “Drill and Fill”

Your contractor will drill a series of 2-inch holes through either the exterior sheathing or interior wallboard, and then blow cellulose or fiberglass insulation into the stud cavities. For the exterior approach, small pieces of siding may need to be removed to expose the sheathing. The patched holes may be noticeable, unless covered with new siding or trim.

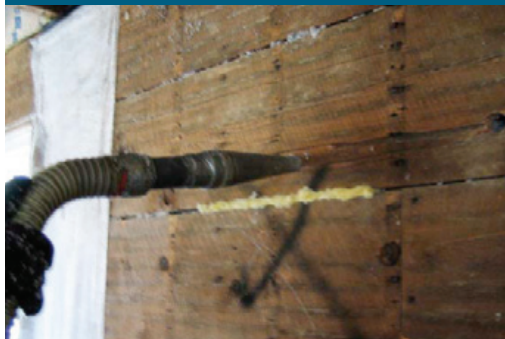
The density of the fiber in the walls determines the R-value achieved. Your contractor may use a “dense-pack” method, which offers a higher R-value. This method also reduces settling within the cavity and air leakage through the wall. However, the walls must be well-sealed and strong enough to accommodate added pressure.

“Drill and fill” is popular and time-proven. It should be done only by a trained professional, who will make sure the insulation completely fills the cavities, at the correct density.



(Top) **Dense-pack fiberglass.** In this newly built home, dense-pack fiberglass is held in place with netting. This is a popular choice for retrofit insulation, blown into open cavities or installed using the drill-and-fill method (Photo Source: Bob Ward Company).

(Bottom) **Cellulose insulation.** Made from recycled newspaper mixed with fire retardant, cellulose insulation is a popular wall insulation choice. Unlike batts, it easily conforms to the space and fits around obstacles, such as wiring and pipes. In this home, the cellulose has been blown dry into open wall cavities, where it is held in place with netting. It can also be mixed with adhesive and sprayed into open wall cavities or blown dry into closed cavities, using the drill and fill method (Photo source: G.W. Robinson).



(Top) **“Drill and fill” from the interior.**

A 19th century New Jersey home undergoing a gut rehab had walls with irregular framing and no insulation. A worker blew cellulose insulation into holes drilled from the interior, completely filling the irregular spaces. On the exterior, insulated vinyl siding provided the air and moisture barrier (Photo Source: PNNL).

(Bottom) **“Drill and fill” from the exterior.**

Workers drilled holes in the siding for blowing insulation into the walls of this home in a Portland, Oregon, historic district. The sealed holes will be hidden when the siding is repainted (Photo Source: PNNL).

Adding Fiber Insulation to Open Wall Cavities

Adding fiber insulation to stud cavities is the least expensive way to insulate a wall. Fiber insulation is most commonly available as fiberglass batts. Loose-fill insulation is also available, made of fiberglass or cellulose. For advantages and disadvantages of the various types of fiber insulation, see the tables in Chapter 3.

Fiber insulation has a big drawback: it can hold moisture, which reduces its R-value and can lead to mold and wood rot. To control moisture in walls and keep fiber insulation dry, walls should be designed to shed water and to dry to the exterior; a continuous air barrier is also important. See Chapter 3 and Appendix B.4 for information on vapor retarders.

Adding Spray Foam Insulation to Open Wall Cavities

Stud cavities can be filled with polyurethane spray foam insulation. Spray foam has the advantage of being an excellent air barrier; it performs the jobs of air sealing and insulating in one step. When installed correctly, it protects the wall from condensation due to indoor moisture. However, using foam instead of fiber does not avoid the problems of thermal bridging at the studs and condensation of outdoor moisture.

Because it is much more expensive than fiber insulation, homeowners are likely to choose spray foam insulation only in applications where a perfect air barrier is needed, such as the shared wall between living space and the garage.

The amount of spray foam required depends on your climate zone. See the tables in Chapter 3 for more information on spray foam’s advantages and disadvantages.



(Left) **Poorly installed batts.** These fiberglass batts have reduced R-value because of the gaps and compressed areas (Photo Source: PNNL).

(Right) **Properly installed batts.** Fiberglass batt insulation should fill the entire cavity without any gaps, folds, tucks, or pinches (Photo Source: PNNL).

Attaching Rigid Foam to the Interior of a Non-Masonry Wall

Walls with wood, vinyl, aluminum, or fiber cement siding can be insulated on either the interior or exterior with rigid foam insulation. Rigid foam reduces thermal bridging and is a good air barrier when the panels are properly sealed.

Appropriate types of foam board include polyisocyanurate, expanded polystyrene (EPS), and extruded polystyrene (XPS). The foam board should be unfaced. All foam requires an ignition barrier for fire safety. Before installing, check your local building and fire codes.

If the interior drywall is removed, rigid foam panels can be nailed or glued to exposed studs according to the manufacturer's instructions. Fiber cavity insulation can be added for additional R-value. Edges and seams should be carefully sealed with caulk, tape, or spray foam. Complete the wall with ½-inch gypsum board, which provides the necessary ignition barrier. Do not cover the walls with vinyl wallpaper or any other Class I vapor retarder.

Insulating Lathe and Plaster Walls

You can remove the lathe and plaster, then insulate the cavities with spray foam, cellulose, or dense-pack fiberglass, and put up sheetrock. Batts are not a good option because the framing cavities are seldom uniform in older houses. If you want to keep the lathe and plaster wall, the best way to insulate the walls is to add rigid insulation on the exterior of the walls. Otherwise, you should probably leave the walls uninsulated and just do airsealing. Drill-and-fill from the outside may damage the inside wall by breaking off the plaster "keys" behind the lathes. It may also create moisture problems. Furthermore, drill and fill should not be used if there is knob-and-tube wiring in the wall. Adding insulation can push the wiring against the wood studs, creating a fire hazard. Drill and fill is not recommended from the inside because it can damage the plaster, it can disturb lead paint, and it will produce a lot of dust.

The National Park Service, Technical Preservation Service, recommends against adding insulation to the walls in historic buildings: "Adding blown-in insulation to historic wall assemblies may trap moisture within the wall and lead to accelerated and often hidden deterioration of the structure... as the wall is repaired. It is best to limit insulation to attics and basements where it can be installed with minimal damage to the historic building." The Technical Preservation Service recommends adding wall insulation only "if walls are so deteriorated that complete replacement is required," then "insulation can be properly installed."



Interior rigid foam. To create an air barrier, seams of the rigid foam insulation were carefully sealed with spray foam (Photo Source: PNNL).



Exterior rigid insulation. A complete renovation of this Massachusetts home included insulating the walls with exterior rigid insulation and interior cellulose (Photo Source: BSC).

5.3.3 Stud-Framed Walls: Adding Exterior Insulation

If you are replacing your siding, you have several options. This section provides guidance on the following approaches to insulating the exterior of a non-masonry wall:

- Adding exterior rigid foam insulation
- Installing a proprietary wall insulation system (rigid foam blocks, an exterior insulation finish system, or insulated vinyl siding).

Adding Exterior Rigid Foam Insulation to a Non-masonry Wall

When replacing siding, it may be cost-effective to install exterior rigid foam insulation as part of your project. Rigid foam, also known as insulating sheathing, can be made of extruded polystyrene (XPS), expanded polystyrene (EPS), or polyisocyanurate. XPS is water-resistant and provides structural strength. EPS is the least expensive and the most vapor-permeable. Polyisocyanurate absorbs water, but it comes with a foil facing that can make a good drainage plane when well sealed. For further descriptions of each type of rigid foam insulation, see the tables in Chapter 3.

Advantages of insulating walls with exterior rigid foam:

- Properly installed, it will keep your exterior walls warm and dry, avoiding the risk of condensation, mold, and moisture damage.
- It provides a high R-value for its thickness.
- Because it covers the studs, it stops thermal bridging – the gain or loss of heat through the studs.
- It can be installed over the existing sheathing. Alternatively, XPS rigid foam can be used instead of wood sheathing.
- You usually can stay in your home while the work is done, with no disruption to the interior.

Drawbacks of insulating walls with exterior rigid foam:

- It is expensive.
- Doors and windows will need new flashing to integrate them with the rigid foam, which serves as a drainage plane. If the window frames are sealed improperly or to the wrong surface, water can get inside the wall cavities.
- Adding the foam may create a thicker wall assembly. If it does, the door and window jambs and sills may need to be extended. This can require removal and reinstallation of the windows and doors.

See Appendix C for performance briefs on

Integrating sidewall and kick-out flashing
with rigid foam exterior insulation.

Tips for installing rigid foam insulation. Rigid foam panels are available in several thicknesses, from $\frac{3}{4}$ inch to 4 inches. To create a tighter air and moisture barrier, four inches of foam insulation can be attached in two 2-inch layers, with the joints offset both horizontally and vertically. Your contractor should attach the rigid foam with strong screws that extend from wood strapping on the outer surface, through the foam, and into the framing. The foam panels should fit together tightly.

All edges and seams must be sealed to make an airtight, water-resistant assembly. Construction adhesive or silicone sealant can be used in outside corners and places where the foam meets the wall plates. Your contractor should apply housewrap tape over all seams and inside corners, and where the foam meets windows and doors.

Do not put vinyl wallpaper or oil or epoxy paint on the interior face of the wall. Follow local codes regarding fire protection and setback requirements.

Proprietary Wall Insulation Systems

There are several proprietary products for insulating exterior walls.

Exterior rigid foam blocks. Several companies make rigid foam block insulation that is attached to sheathing with screws. The blocks are installed in courses, like a brick wall. The first course fits in a metal track attached to the wall. Clips are attached to the blocks or base plate to maintain a drainage and ventilation cavity. Properly installed, exterior foam blocks provide a high R-value and an effective air and moisture barrier. Siding is attached to the blocks. As with any exterior insulation approach, the thickness of the foam blocks can pose difficulties. The windows and doors must be properly flashed, and the door and window jambs and sills may need to be extended. This can require removal and reinstallation of the windows and doors.

Exterior insulation finish systems (EIFS). If you would like your new siding to look like stucco, your contractor may recommend using an exterior insulation finish system (EIFS). This approach provides a waterproof, insulated covering for all wall surfaces, including the attic gable end walls.

For non-masonry walls, the existing siding must be removed. The sheathing should be fiberglass-faced gypsum board, which is moisture resistant. Insulating foam is attached directly to the sheathing (AWCI 1994). Wire or fiberglass mesh is attached over the foam. The assembly is covered with a proprietary finish. There are several brands available. Care must be taken with structural shear issues.



Exterior foam block insulation.

These blocks stack up like bricks. The insulation shown provides an R-value of 18 (Photo Source: DOE).



Insulated vinyl siding. Rigid foam insulation is permanently attached to the vinyl siding (Source: NAHB).

Often called “synthetic stucco,” EIFS can be effective in most climate zones, depending on the thickness of the foam insulation. Although EIFS have been associated with moisture damage (Lstiburek 2007), Building America scientists have found that EIFS can be durable if drainage and water management details are constructed correctly. A continuous drainage plane and good flashing are required (Straube and Smegal 2009, Lstiburek 2004a).

As with any exterior insulation approach, the door and window jambs and sills may need to be extended. This can require removal and reinstallation of the windows.

Insulated vinyl siding. Insulated vinyl siding has rigid foam insulation permanently attached to the vinyl. The insulation, usually expanded polystyrene (EPS), provides some moisture protection along with R-value. For installation, your contractor will follow the product instructions.

5.3.4 Masonry Walls: When and Where to Insulate

A masonry wall may be solid; more typically, it is built with two or more rows (wythes) of brick, stone, or concrete that have a drainage and ventilation cavity between them. The cavity varies from about 1 inch to 4 inches in width. The face of the second row serves as a drainage plane.

When to Insulate a Masonry Wall

- When there are comfort problems or moisture issues.
- When structural problems in the masonry walls require new siding.
- When a major remodeling project allows for removal of plaster or drywall to expose the interior side of the brick, stone, or concrete.

How to Insulate a Masonry Wall

Your choices for insulating masonry walls are limited and expensive. Exceptional care must be taken to prevent condensation, mold, and moisture damage when insulating masonry walls. Building America researchers have found that three approaches can be successful:

- exterior rigid foam
- interior spray foam
- * interior rigid foam.

Building America researchers do NOT recommend the use of fiber insulation in direct contact with a masonry wall. Fiber insulation (fiberglass batts or cellulose) next to a masonry wall will absorb moisture, creating a risk of mold, mildew, and structural damage.

5.3.5 Masonry Walls: Adding Exterior Insulation

Both cavity and solid masonry walls can be insulated from the outside with rigid foam insulation.

Rigid foam offers some advantages. Properly installed, it will keep your exterior walls warm and dry, avoiding the risks of condensation, mold, and moisture damage. You usually can stay in your home while the work is done, with no disruption to the interior.

However, the aesthetic value of an aged brick or stone wall will be lost when it is covered by the rigid foam and new siding. Additionally, rigid foam is expensive and, combined with the new siding, creates a thicker wall assembly. The door and window jambs and sills may need to be extended. This can require removal and reinstallation of the windows and doors. Building America scientists suggest combining window replacement with a siding and insulation project. The new window jambs can be sized to fit the new wall thickness (Ueno 2010).

Your contractor can attach rigid insulation to the existing masonry, using fasteners or glue recommended by the foam manufacturer. All edges and gaps must be sealed carefully. Stucco or an exterior insulation finish system (EIFS) should be installed over the rigid foam, leaving a drainage and ventilation space between the foam and the siding.

5.3.6 Masonry Walls: Adding Interior Insulation

For some homeowners, covering masonry walls with exterior insulation is unacceptable because of aesthetics or historic home requirements. In these cases, Building America researchers recommend applying spray foam insulation on the interior of the walls. While spray foam is expensive, it provides air sealing and good R-value. However, installing insulation on the interior has two major drawbacks:

- **Risk of moisture damage.** Adding interior insulation to a masonry wall creates a serious risk of moisture damage. Bricks and other types of masonry readily absorb moisture from rain and humid air. Once interior insulation is in place, less warmth passes through the wall. The bricks, stone or concrete will be colder, increasing the amount of condensation and extending the time it takes to



Exterior rigid foam. Rigid foam insulation is installed on the exterior of a new framed home in Georgia. The rigid foam takes the place of OSB wall sheathing (Photo Source: IBACOS).



(Top) **Interior rigid foam insulation.** Rigid foam has been installed on the interior basement walls of this new home in Pennsylvania. The ground has also been covered with rigid foam, in preparation for pouring the concrete floor slab (Photo Source: IBACOS).

(Bottom) **Rigid foam insulation.** As part of an energy-efficient retrofit, rigid foam insulation will be used to insulate a basement (Photo Source: PNNL).

dry. This may lead to mold, mildew and rusting of embedded steel supports. Where winter temperatures go well below freezing, repeated freeze-thaw cycles can permanently damage the walls.

- **Loss of floor space.** Insulation installed on the interior needs a new stud wall built in front of it to attach wallboard. The thicker wall will reduce a room's square footage.

While loss of floor space is unavoidable, moisture risks can be minimized. This requires two strategies:

- **First, minimize rain absorption.** Reduce the amount of rainwater absorbed by the masonry in two key places: the bottom corners of windows and the wall at grade level. Adding projecting window sills and base drainage will do the most to reduce water absorption.
- **Second, create an airtight wall.** This is easiest to achieve with spray foam insulation. It creates a continuous air barrier to prevent the movement of moisture-laden air from the living space into the wall. If you are using rigid foam insulation, edges and seams must be carefully sealed.

Installing Interior Spray Foam Insulation on a Masonry Wall

Building America scientists have found spray foam to be both the most successful and practical approach to insulating the interior of both cavity and solid masonry walls (Straube 2007). Both high-density closed-cell and medium-density open-cell foam create excellent air barriers and eliminate the need for separate air sealing measures.

Before applying the foam, Building America scientists recommend constructing a steel-stud wall 2 inches away from the masonry wall. (The space allows complete coverage of the wall and reduces thermal bridging.) The foam is then sprayed directly on the entire surface of the masonry at a thickness of 2 to 4 inches.

Once the foam is in place, fiber insulation can be installed in the stud cavities for additional R-value. Drywall is then attached to the studs. Do not use vinyl wallpaper or any other kind of Class I vapor retarder on the inside face of the wall.

Installing Interior Rigid Foam Insulation on a Masonry Wall

Rigid foam can be used to insulate the interior of masonry walls. However, Building America researchers have found that rigorous attention to detail is required to avoid moisture problems. It is difficult to create a perfect air barrier and to get the rigid foam to adhere to the masonry at every point. Even small gaps will make the insulation less effective and create a spot for moisture to condense (Straube 2007).

Rigid insulation should be installed in amounts that permit indoor drying: Up to 2 inches of XPS or unfaced polyisocyanurate, or up to 4 inches of the more vapor-permeable EPS (Lstiburek 2006d; Straube 2007).

Your contractor should take the following steps:

- Apply a liquid, highly vapor-permeable air and water barrier to the exterior of the masonry. This serves as an air barrier and keeps water from penetrating, yet allows the wall to dry in either direction.
- Attach the rigid foam panels to the interior of the masonry with construction adhesive applied in a serpentine pattern.
- Make sure the panels are fully in contact with the masonry wall, with no gaps.
- When using two layers of foam, stagger the seams.
- Create airtight seals where the foam panels meet and where they join other materials. Use acrylic-latex caulk, foam sealant, or mastic.



Wet masonry. Avoid insulation strategies that increase moisture retention in masonry walls. Wet masonry can develop mold and efflorescence, a chalky salt residue (Photo Source: PNNL).

5.4 Insulating a Crawlspace

Insulating your crawlspace can reduce your energy bills and make your home more comfortable. However, taking the wrong approach can create moisture and air quality risks. Your decisions about crawlspace insulation must take into account your climate (Figure 5.12) and the radon level in your soil.

- **HUMID** climate zones: A vented crawlspace in a humid climate zone is vulnerable to serious moisture problems (Malkin-Weber et al. 2008). Adding insulation on the ceiling of a vented crawlspace will increase the risk of mold and wood rot (Lstiburek 2008b). If you live in a humid climate outside a flood-prone area, Building America scientists recommend closing the vents, air sealing the crawlspace walls and floor, and insulating the walls of the crawlspace.
- **DRY** climate zones: Both vented and closed crawlspaces can perform well in dry climate zones, where airborne moisture is seldom a problem (Hales 2011). In hot-dry zones, adding insulation to a crawlspace is unlikely to be cost-effective (Straube 2011). In other dry zones, several insulation approaches are recommended, as discussed below.

Climate is the crucial consideration in crawlspace decisions. In humid (moist) zones, vented crawlspaces can have moisture problems. Building America scientists recommend closing and sealing the crawlspace and insulating the crawlspace walls. In dry and marine climates, either closed or vented crawlspaces can work well.

- **MARINE** climate zones: Building America partners and other researchers have found that airborne moisture is seldom a problem in the marine climate zones of the western United States. Both vented and insulated closed crawlspaces can perform adequately (Hales 2011).
- **RADON:** In areas with high levels of radon in the soil, vented crawlspaces have the advantage of diluting the gas. Closed crawlspaces require a radon mitigation system, because radon can become concentrated (DOE 2010d). Although radon maps provide the historical and statistical probability of increased radon in your geographic area, the only way to know if you have high levels in your home is to test for radon.

Even where vented crawlspaces perform adequately, it can be an advantage to close and seal the crawlspace before insulating. Closed crawlspaces typically perform better than vented crawlspaces in terms of safety, health, comfort, durability, and energy consumption (Lstiburek 2006a). Where radon is not a problem, the U.S. Environmental Protection Agency (EPA) recommends closed crawlspaces for indoor air quality (EPA 2006).

This section describes recommended approaches to crawlspace insulation for humid climates and for dry and marine climates. The research-based guidance, developed by Building America scientists, will help you insulate your crawlspace safely and effectively. Be sure to hire a contractor certified in building science. A knowledgeable contractor will help you choose the best approach for your home.

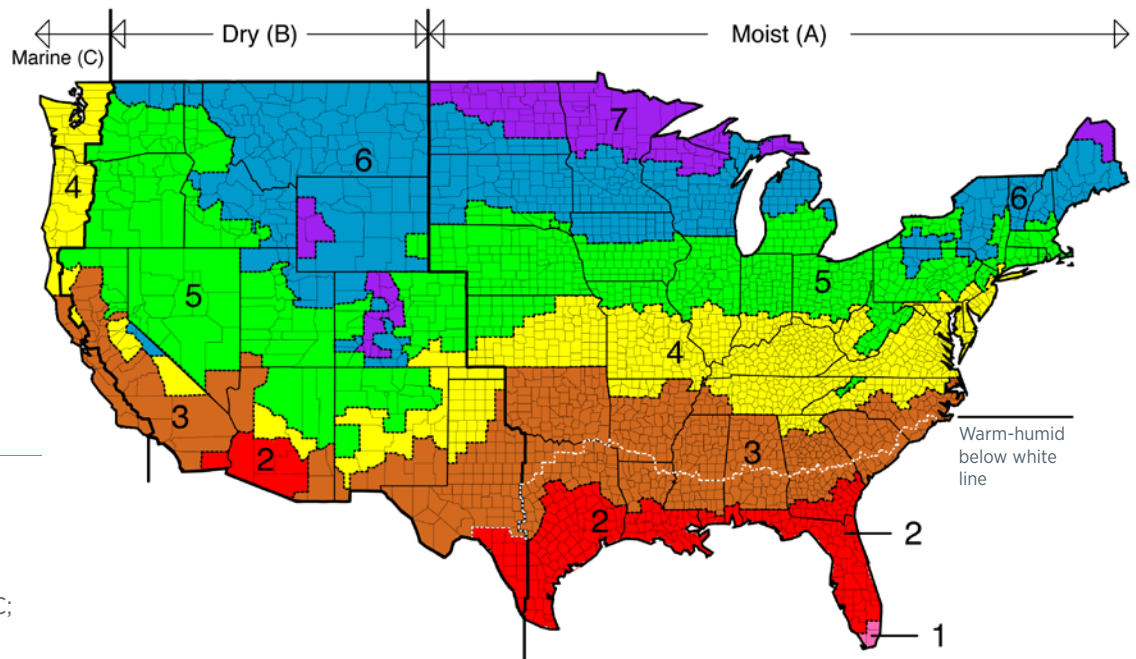


Figure 5.12. IECC climate regions. Designated by the International Energy Conservation Code (IECC) (Figure Source: 2009 IECC; Briggs et al. 2003).

5.4.1 Why Crawlspace Vents Should be Closed in Humid Climate Zones

In humid climates outside of flood-prone areas, Building America scientists recommend closing the crawlspace vents before adding insulation. A vented crawlspace in a humid climate can compromise the structural integrity of a home and the health of the occupants (Advanced Energy 2011). Air entering through the vents can deposit moisture in the crawlspace, leading to mold and wood rot. The crawlspace air then gets pulled into the living space by the stack effect, bringing in moisture and any mold spores that have formed (see sidebar). Mold contributes to respiratory problems, such as asthma.

A vented crawlspace insulated with batts or cellulose in the crawlspace ceiling has an even higher risk of moisture accumulation, mold, and wood rot. Fiberglass batts installed between the floor joists in a vented crawlspace are cool on the underside, and the exposed bottom edges of the floor joists are even cooler. If these temperatures are below the dew point, condensation will form. The damp batts will insulate poorly, mold can grow, and the damp, exposed floor joists can rot (Lstiburek 2008b). Cellulose insulation installed between the floor joists can develop the same problems.

Done properly, closing the crawlspace will minimize or eliminate moisture risks (Lstiburek 2006a). Closing the crawlspace can also reduce the energy used for heating and air conditioning your home, especially if ducts and heating equipment are located in the crawlspace (Lstiburek 2006a; Malkin-Weber et al. 2008). Savings can be reduced, however, if local conditions require supplying warm air to the crawlspace in winter or continuously running an exhaust fan (Hales 2011).

Note: You must test for radon before closing a crawlspace. If radon levels are high, you must install an appropriate radon mitigation system before closing the crawlspace (see Chapter 4). Radon can become concentrated in a closed crawlspace.

5.4.2 Insulation for a Closed Crawlspace

Building America researchers have found that rigid foam and spray foam insulation on the interior side of closed crawlspace walls can give good results in most areas. In cold climates, however, interior wall insulation can increase the wall's vulnerability to thermal stress and freezing, and may increase the likelihood of condensation on sill plates, rim joists, and joist ends (DOE 2010d). Foam insulation installed on the *exterior* of crawlspace walls can solve these cold-climate problems, but the approach is usually impractical for existing homes. See Section 5.3.5 for information on exterior wall insulation.

Crawlspace vents create moisture risks in humid climates

Crawlspace vents are supposed to prevent moisture problems. The assumption has been that fresh air will enter through a vent on one side, and stale air with moisture and contaminants will be pushed out the other. Unfortunately, cross-ventilation doesn't work well in crawlspaces; air is more likely to be pulled up into the living space by the stack effect. Studies by Building America research partners have found that 40% to 50% of the air in a typical home has been in the crawlspace at one time (Dastur and Davis 2005; DOE 2011a).

Structural risks. In humid climates, air entering through the vents carries water vapor. The vapor will condense on the cooler surfaces of the floor joists and foundation walls if their temperatures are below the dew point. If framing stays moist, mold and wood rot will develop. Moist wood also attracts termites and carpenter ants. The floor above a crawlspace ceiling can also be damaged by airborne moisture. Hardwood floors can buckle and warp. If a floor is covered with vinyl, mold may develop underneath it.

Health risks. A home is likely to have high mold counts inside the living space when the crawlspace has high moisture levels (Malkin-Weber et al. 2008). Mold contributes to respiratory problems, such as asthma.

Air conditioning can increase moisture risks. In an air-conditioned home where ducts are in a vented crawlspace, airborne moisture can condense on the duct surfaces, both inside and out, possibly leading to mold. Subflooring around floor registers in the crawlspace ceiling can become cold and damp and may develop mold (Lstiburek 2008b).



Insulation for unvented crawlspaces.

(*Top*) Rigid foam was used to insulate this unvented crawlspace (Photo Source: WSU Energy Office).

(*Bottom*) This unvented crawlspace was insulated with rigid foam on the walls and spray foam at the rim joist (Photo Source: W. Hawthorne).

Spray foam insulation. Two types of spray foam can be used to insulate the interior side of a crawlspace wall—open-cell and closed-cell. Open-cell foam costs less than closed-cell foam, but has a lower R-value per inch. Both will provide a good air barrier and enough vapor permeability to allow moisture in the walls to evaporate to the inside (open-cell foam is more permeable than closed-cell). Recommended amounts for crawlspace walls include:

- 3 inches of closed-cell, medium-density spray foam
- Ten inches of open-cell, low-density spray foam (BSC 2009b).

Rigid foam insulation. Two types of rigid foam can be used to insulate the interior side of a crawlspace wall:

- Up to 2 inches of unfaced extruded polystyrene rigid foam (XPS)
- 4 inches of unfaced expanded polystyrene (EPS) (BSC 2009b).

Fiber insulation (fiberglass batts or cellulose) should not be used against a crawlspace wall. Fiber insulation collects and holds moisture (Yost and Lstiburek 2002).

5.4.3 How to Seal and Insulate a Crawlspace

Moisture Control

Creating a dry, closed crawlspace requires careful preparation. Moisture control is crucial:

Air sealing is the primary defense against condensation. Your contractor must create a tight air barrier to prevent the entry of airborne moisture. Simply closing the vents without performing air sealing is likely to make moisture levels higher and may cause damage.

A ground vapor retarder must be installed to prevent evaporation of ground moisture into the closed crawlspace. The IRC requires a Class 1 vapor retarder that is overlapped at the edges, taped, and sealed to walls.

Conditioned air must circulate in the crawlspace for the space to remain dry (see the 2009 IRC R408.3 requirements listed in the sidebar on page 59). Your certified home performance contractor can advise you on the best system for your house.

Steps to Close and Insulate a Crawlspace

Be sure to hire a contractor certified in building science (see Chapter 1) to ensure that all technical and safety issues are addressed. Your contractor should do the following:

1. PLAN:

- Check with the local building department. Some areas do not permit closed crawlspaces. However, the International Residential Code (IRC) allows unvented crawlspaces as long as the ground is covered with a properly installed vapor retarder, the perimeter walls are insulated, and the crawlspace has a drying mechanism. This can include passive air exchange with the living space, a dehumidifier, or a power vent to the outdoors.
- Many builders have gotten permission by showing their code officials that the crawlspace will be a conditioned space, like a miniature basement.
- Check with local pest control officials on ways to ensure access for termite inspections.
- Plan access once the crawlspace is closed. Plan for an access door inside the home, through the subfloor, or an airtight, insulated door in the perimeter wall.

2. TEST FOR RADON:

- Low-cost do-it-yourself kits are widely available (see sidebar, next page). If radon is a concern, a radon mitigation system must be installed before proceeding any further.

3. PROTECT THE CRAWLSPACE FROM WATER SOURCES:

- Make sure the yard and pavement slope away from the crawlspace.
- When the crawlspace ground level is below the surrounding grade, crawlspaces should have perimeter drainage, just like a basement.
- Monitor for water intrusion after the work is complete.

4. ADDRESS EXISTING MOISTURE DAMAGE:

- Remove any existing insulation.
- Replace rotting wood.
- Clean the walls.

IRC Code for Closed Crawlspaces

A closed crawlspace is permitted under the 2009 and 2012 International Residential Code (R408.3) if all of the following conditions are met:

1. Exposed earth is covered with a continuous Class I vapor retarder. Joints of the vapor retarder shall overlap by 6 inches (152 mm) and shall be sealed or taped. The edges of the vapor retarder shall extend at least 6 inches (152 mm) up the stem wall and shall be attached and sealed to the stem wall or insulation; and
2. One of the following is provided for the under-floor space:
 - 2.1. Continuously operated mechanical exhaust ventilation at a rate equal to 1 cubic foot per minute (0.47 L/s) for each 50 square feet (4.7m²) of crawlspace floor area, including an air pathway to the common area (such as a duct or transfer grille), and perimeter walls insulated in accordance with Section N1103.2.1 of this code;
 - 2.2. Conditioned air supply sized to deliver at a rate equal to 1 cubic foot per minute (0.47 L/s) for each 50 square feet (4.7 m²) of under-floor area, including a return air pathway to the common area (such as a duct or transfer grille), and perimeter walls insulated in accordance with Section N1102.2 of this code;
 - 2.3. Plenum in existing structures complying with Section M1601.5, if under-floor space is used as a plenum.

Radon in Crawlspaces

For your health's sake, you must check for radon before deciding to close a crawlspace. Radon is a naturally occurring gas that causes lung cancer. Odorless and invisible, it is produced by the radioactive breakdown of trace uranium in soil. (See Chapter 4, "Safety and Health.")

Researchers have found that closing a crawlspace can concentrate radon to unacceptable levels. Based on these findings, researchers concluded that closed crawlspaces in high radon areas should be vented with an active, fan-powered radon mitigation system, with the fan installed in the attic. The fan must be well maintained and operate at all times (Hales 2011; DOE 2010d).

In many parts of the country, radon levels are low enough that closing a crawlspace is unlikely to cause problems. However, radon beneath any particular home can be high; the only way to know is to test.

Low-cost, do-it-yourself radon test kits are available in stores. If tests indicate a radon level of 2 or more picocuries per liter of air, you must install an appropriate radon mitigation system. Be sure to hire a qualified radon contractor. With the system installed, then you can close the crawlspace. Perform a radon test again after the work is done. To find a qualified or state-certified radon contractor in your area, check with your state radon office or see www.epa.gov/radon/wherelive.html.

For information on crawlspace exhaust fans

"Details for Mechanically Vented Crawlspaces - Code Notes," at <http://resourcecenter.pnl.gov/cocoon/morf/ResourceCenter/article//131>

5. ADDRESS COMBUSTION EQUIPMENT ISSUES:

- If oil or gas furnaces or water heaters are located in the crawlspace, they should be sealed-combustion units equipped with a powered combustion system. Natural draft combustion appliances are more likely to backdraft in a closed crawlspace due to power venting of the space or the stack effect.

6. AIR SEAL THE CRAWLSPACE:

- Carefully seal all holes and cracks in the subfloor over the crawlspace.
- Seal all air leaks through the exterior wall, including the rim joist.
- Make sure any ductwork is sealed with mastic, not ordinary duct tape. (See the performance brief on ducts in Appendix C.)

7. PROVIDE CONDITIONED AIR:

- Allow passive air exchange between the closed crawlspace and the living space by installing floor registers or transfer grilles. If humidity in the crawlspace is still a concern:
 - Install supply ducts if the home is air conditioned.
 - If it is not air conditioned, install a small dehumidifier.
- Where soil gases are a problem, install a durable fan to exhaust air continuously from the crawlspace to the outside (Lstiburek 2006b).

8. PROTECT AGAINST GROUND MOISTURE:

- Cover the ground with a polyethylene liner at least 6 millimeters thick, sealed at the seams and sealed to the crawlspace walls to the height of the exterior grade and fastened to the wall with pressure-treated furring strips.

9. CLOSE THE VENTS

- Insert cinder blocks or foam plugs and seal with mastic.

10. INSTALL INSULATION

- Make sure the surface is completely dry.
- Install according to the manufacturer's instructions.
- Cover all types of foam with an ignition barrier for fire safety, such as ½-inch gypsum board. Spray foam can be painted with ignition barrier paint.
- Insulate the access door and make it airtight.

11. TEST AND CHECK

- Test again for radon. Even if previous tests showed no elevated radon levels, you should test again for your health and safety. Sealing and insulating a crawlspace can increase the concentration of radon.
- Make sure the polyethylene ground cover has no tears or holes.
- Consider installing a wireless humidity sensor, paired with an alarm inside the home (Advanced Energy 2011).

5.4.4 Insulating a Crawlspace in Dry and Marine Climate Zones

Your Choice: Vented or Unvented

Research indicates that both closed and vented crawlspaces are acceptable in the dry and marine climates of the western United States. A closed crawlspace can have advantages in terms of energy efficiency and improved air quality, especially if ducts are located in the crawlspace. It also provides protection against freezing pipes. On the other hand, keeping the crawlspace vented may be the best option for your home. Closing a crawlspace costs money. In a high-radon area, a closed crawlspace requires the installation of a radon-mitigation system (see sidebar on previous page).

A home performance contractor who is certified in building science can identify the approach that will best increase your comfort, improve air quality, and reduce energy bills.

How to Insulate a Vented Crawlspace in Dry and Marine Climates

If you choose to keep your crawlspace vented, your contractor will install insulation on the crawlspace ceiling. Several products can be used:

- Unfaced batts can be installed between the floor joists, in contact with the floor above. Make sure there is no airspace between the insulation and the crawlspace ceiling (DOE 2010d). Support the insulation with rigid foam board, mechanical fasteners, or inexpensive landscape cloth so it will not fall out of the joist spaces in the years to come. Avoid pinching or compressing the batts; this reduces their R-value.

Figure 5.13. Foil-faced insulation in crawlspace. Foil-faced insulation can be added to the underside of floor joists in a vented crawlspace. The rigid insulation keeps floor joists warm and the foil facing is a Class I vapor retarder that keeps crawlspace air from condensing on the floor joists as long as the foil-faced insulation is taped at all seams with foil tape. Any type of floor covering will work with this insulation and it will work in any climate zone (Source: Lstiburek 2008b).

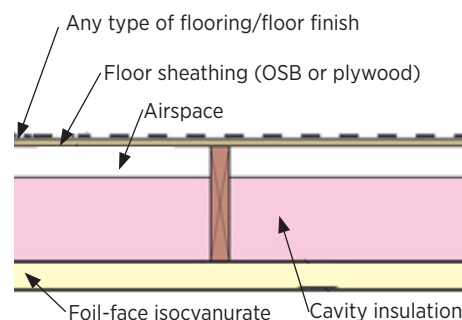
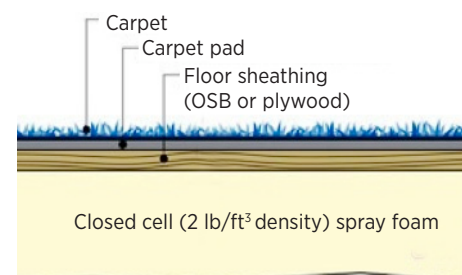


Figure 5.14. Spray foam insulation in crawlspace. Spray foam insulation will create an air barrier on the ceiling of a vented crawlspace, keeping the floor above it warm and dry. The foam should completely encase the floor framing. A minimum of 3 inches of high-density closed-cell foam should provide an adequate vapor retarder for any floor type including vinyl, in any climate zone. If using low-density foam or a thinner layer of high-density foam, avoid vinyl flooring (Source: Lstiburek 2008b).





(Top) **Poor insulation.** Here batt insulation is no longer attached and is falling away from the floor above. To be effective, batt insulation must be in full contact with the crawlspace ceiling, and a vapor retarder of 6-mil visquene should fully cover the crawlspace ground (Photo Source: PNNL).

(Middle) **Good insulation.** This photo shows a vented crawlspace with batt insulation that is properly fastened to be in full contact with the subfloor above.

(Bottom) In hot-humid and/or coastal climates where a pier foundation is used, spray foam can be applied to the underside of the subfloor to both insulate and air seal it.

- Rigid insulation can be attached to the underside of the floor trusses, with the seams carefully sealed. For additional R-value, loose-fill insulation can be blown into the space above.
- Cellulose insulation can be installed with netting for support.

Before work begins, your contractor should:

- Test for radon. If the radon level is high, install a mitigation system before proceeding further.
- Air seal the crawlspace ceiling. Plug leaks in the rim joists and air seal all plumbing, electrical, and duct penetrations. For details, see Building America's Air Sealing Guide at http://apps1.eere.energy.gov/buildings/publications/pdfs/building_america/ba_airsealing_report.pdf.
- Air seal and insulate pipes and ducts to protect against heat loss and freezing (see Appendix C for instructions).
- If the crawlspace opens to the house, insulate and air seal the crawlspace access cover.

5.5 Insulating Basements

Insulating your basement—when done properly—will increase your comfort, save energy, improve your home's air quality, and make your home more durable (DOE 2002). However, a dry basement requires careful moisture control and air sealing before insulation is added. Be sure to hire a contractor certified in building science. A knowledgeable contractor will make moisture control and air sealing the first priority.

Your basement may already be damp, cold, and musty. According to Building America researchers, the best remedy is air sealing and expertly installing foam insulation on your basement walls. You will need to supply heating and air conditioning to your basement. In dry climates, insulation can be installed on the basement ceiling instead, as long as you don't use your basement as living space.

This section provides guidance for achieving a dry, energy-efficient basement, with steps for:

- 5.5.1. Moisture Control and Air Sealing
- 5.5.2. Choosing the Best Approach for Insulating your Basement
- 5.5.3. Preparing to Insulate
- 5.5.4. Insulating Basement Walls on the Interior

5.5.5. Insulating Basement Walls on the Exterior

5.5.6. Insulating Basement Ceilings

5.5.7. Maintaining a Dry, Problem-Free Basement.

5.5.1 Moisture Control and Air Sealing

Contact with cold earth makes basements vulnerable to moisture, mold, and rot. Adding insulation to a basement with existing moisture problems will only make them worse. Moisture control is crucial.

Moisture in basements comes from two sources:

- **Water intrusion.** Rainwater, groundwater, and water from your sprinklers can wick through the walls or up from the footings.
- **Condensation.** Condensation can occur when air comes into contact with cold surfaces. Since basements are mostly below ground level, they are chilled by the surrounding earth. The moisture in basement air will condense on the walls and floor joists if those surfaces are below the dew point temperature. The wood framing and any batt insulation and gypsum board can stay chronically damp.

The first step in controlling moisture is to evaluate its presence in your basement. If at times you can see moisture on the walls or if water sometimes drains from the walls onto the floor, you have a serious problem. Your contractor must install an interior drainage system before taking any other steps.

The next step is to fix any sources of water intrusion and perform air sealing. Air sealing is a crucial defense against condensation, because it keeps moist air away from cold basement surfaces. Your final step in moisture control will be to add insulation. Insulation will further reduce condensation by raising basement temperatures.

5.5.2 Choosing the Best Approach for Insulating your Basement

This section provides guidance on where to insulate and how to choose an insulation product for your basement.

Where to Insulate: Walls or Ceiling?

Your first step is to determine whether to insulate the walls or ceiling of your basement. Factors include your climate and how you want to use your basement:

Recognize the signs of basement moisture problems:

- Foundation cracks that leak
- Standing water that doesn't drain
- Damp walls or floor
- White, chalky stains (called efflorescence) on walls and floors
- Mildew or visible mold
- Wet, decaying wood
- Condensation on windows, pipes, and other fixtures
- Damp insulation
- Moisture-damaged finishes
- Musty or damp carpets
- Stuffy, damp smells
- High humidity.



Basement ceiling insulation. Unfaced fiberglass batts are installed in the ceiling of this basement in Portland, Oregon (Photo Source: PNNL).

Insulate the ceiling. You can choose to insulate the ceiling and leave the basement unheated only when ALL of the following are true:

- You live in a dry climate, and
- you find no evidence of moisture, and
- you don't use your basement as living space.

Insulate the walls. You should insulate the basement walls and supply heating and air conditioning when any ONE of the following is true:

- You want to use your basement as living space, or
- you live in a humid climate zone, or
- your basement shows evidence of moisture.

Basement Ceilings: Choosing Insulation

Spray foam, rigid foam, and fiber insulation can all be used to insulate basement ceilings. Spray foam has the advantage of providing air sealing and insulation in one step. Fiberglass batts are much less expensive than foam, and will perform well in a dry climate as long as the ceiling is air sealed. Section 5.5.6 provides guidance for insulating a basement ceiling.

Basement Walls: Choosing Insulation

Your goal is a basement with dry, warm walls. This requires strategies to keep moisture out of the walls. However, it is inevitable that walls will get wet sometime, and the walls must be able to dry out. Moisture cannot dry to the exterior where the walls are below grade. Therefore, insulated basement walls must have these features:

- **To discourage condensation**, the walls need an air barrier to keep moist interior air from reaching the foundation. The walls need to be kept warmer than the dew point of the air.
- **To prevent moisture retention**, insulated walls must be able to dry to the interior. The insulation must not retain water and the wall must not have a Class I vapor retarder on the interior. Vapor retarders to be avoided include foil, plastic, vinyl wallpaper, and oil, alkyd, and epoxy paint (Lstiburek 2006b). Foil-faced polyisocyanurate may be an exception; see the discussion below, under “Basement Walls: Spray Foam or Rigid Foam Insulation.” Do not use fiberglass batts or cellulose insulation; they hold water.
- **To reduce moisture** wicked up by the foundation, leave a ½- to ¾-inch gap between the gypsum wallboard and the concrete floor.

With these factors in mind, Building America scientists provide the following appraisal of the three ways to insulate basement walls:

1. *Unacceptable*: Putting fiberglass insulation in framing cavities and covering it with a Class I vapor retarder, such as plastic sheeting.
2. *Recommended*: Installing rigid or spray foam insulation on the interior of the walls.
3. *Recommended when feasible*: Installing rigid insulation on the exterior of the walls.

Note: Although a Class I vapor retarder should NOT be used on the interior side of a basement wall, a Class II or III vapor retarder may be called for. See Section 3.2 and Appendix B.4 for details on vapor retarders.

Basement Walls: Interior or Exterior Insulation?

Most homeowners will choose to insulate their walls on the interior because exterior rigid foam insulation is difficult and expensive to install on the foundation of an existing home. Nonetheless, the exterior approach has some advantages:

- Exterior foundation insulation provides better moisture control than interior insulation, according to Building America researchers (DOE 2011a).
- It discourages condensation by warming the foundation walls, and any moisture in the walls can easily dry to the interior of the basement.
- It protects the foundation from the risk of freeze-thaw cycles that can occur in very cold regions.

Exterior rigid insulation also has some disadvantages:

- It must be protected from moisture while being installed.
- It can become an “insect highway” for termites to reach the wood framing. Many Southern states prohibit its use.
- Exterior insulation requires excavating around the foundation to a depth of at least 2 feet (up to 8 feet in very cold climates). This is cost-effective only if your project includes installing a perimeter drainage system.

Section 5.5.4 provides guidance for installing interior basement wall insulation. Section 5.5.5 provides guidance for the exterior approach.



Basement wall insulation. In this Pennsylvania basement, rigid XPS foam insulation is attached directly to the concrete basement walls with spray foam. Rim joists are insulated with spray foam. Frame walls will be built to finish the basement (Photo Source: Asdal Construction).

Fiberglass batts with plastic sheeting: Refuse to use in a basement wall

The most common approach to basement insulation can damage your home. Many builders construct interior stud framing in the basement, install fiberglass batts, and cover it all with sheet polyethylene. According to Building America researchers and other scientists, this approach can cause serious problems with mold, odor, and decay (Yost and Lstiburek 2002; Fugler 2002; Ellringer 2002). Cellulose insulation covered by polyethylene can cause the same problems.

Inevitably, outdoor moisture will come in contact with insulation. Water seeps through the porous foundation, and moist air condenses on the cold foundation wall behind the insulation. Fiberglass and cellulose insulation can trap and hold large amounts of water. The wet insulation cannot dry, because the polyethylene traps the moisture. This puts your home at risk for mold, wood rot, and termites, and creates an unhealthy environment for you and your family.



Insulated rim joist. Stop air leakage through the rim (or band) joist at the top of the basement wall with spray foam (shown) or with rigid foam cut to fit in the cavities and sealed around the edges. When insulating the entire basement is too expensive, just sealing and insulating the rim joists will save energy and improve comfort (Photo source: DOE).

Basement Walls: Spray Foam or Rigid Foam?

Building America scientists recommend foam insulation for basement walls. There are two forms of foam insulation: rigid foam and spray foam. Rigid foam can be used as exterior insulation. Both forms can be used on the interior. Also available are proprietary foam board insulation systems.

Properly installed, foam insulation minimizes moisture problems:

- Most foam insulation will not absorb or retain water that seeps through the foundation walls or slab.
- It has enough vapor permeability to allow moisture in the wall to diffuse to the basement interior.
- Spray foam is an excellent air barrier, keeping moist indoor air away from the foundation walls. Rigid foam is a good air barrier when its seams are well sealed.

Spray Foam Insulation

When choosing spray foam insulation, consider the following characteristics:

- Closed-cell spray foam, available in medium- or high-density. Closed-cell foam is both an excellent air barrier and a good vapor retarder. It provides the best moisture control of all interior foundation insulations (Smegal and Straube 2010).
- Open-cell spray foam, which has low density, is an excellent air barrier but not a good vapor retarder. It costs less than closed-cell foam but must be applied much more thickly to attain the same R-value. The thicker walls will decrease the useful interior space.

Rigid Foam Insulation

When choosing rigid foam insulation, consider the following characteristics:

- EPS (expanded polystyrene) is the least expensive rigid foam but is not a good vapor retarder.
- XPS (extruded polystyrene) has a high R-value per inch and is a good vapor retarder. XPS is a better choice than EPS where moisture is an issue.
- Both EPS and XPS should be installed in amounts that permit indoor drying—up to 4 inches of unfaced EPS (R-15), or up to 2 inches of unfaced XPS (R-10) (Lstiburek 2006d).

- Polyisocyanurate has a high R-value per inch. It is usually faced with aluminum foil to protect its surface. Foil is a Class I vapor retarder, and Building America scientists strongly advise against putting Class I vapor retarders in basement walls. However, foil-faced polyisocyanurate may be an exception. An excellent air barrier, it may be successful as interior basement insulation as long as edges and seams are well sealed and the foam is completely adhered to the foundation wall, with no gaps (Straube and Smegal 2009).

Whichever product you choose, plan to install enough foam to meet the recommended R-value for your climate. (See Section 2.2, “How much insulation do you need?”)

Proprietary Rigid Foam Board Systems

You might want to consider a foam board insulation system. Specialty foam board systems can be more effective and faster to install than ordinary rigid foam panels (Kriger and Dorsi 2009). The system boards have fastening strips embedded in their surface, and some have built-in chases for wiring. The boards are installed using a foam-compatible adhesive and mechanical fasteners.

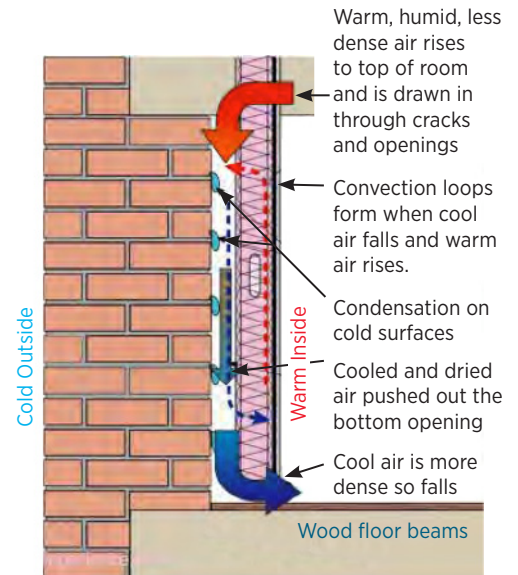
5.5.3 Preparing to Insulate your Basement

A successful project depends on careful preparation. Your contractor should perform the following steps, as needed:

Address Moisture and Mold

- **Address water intrusion.** Make sure rain and groundwater drain away from the foundation. Make sure no sprinklers spray the foundation or wet the ground next to it. Fix plumbing leaks. If you can't remove the source of water, don't insulate.
- **Address interior drainage.** If at times you can see moisture on the basement walls, or if water sometimes drains from the walls onto the floor, you should install an interior drain system before insulating your basement. Serious problems may require a sump pump, excavating and waterproofing exterior foundation walls, and installing drains outside. Your certified contractor can advise you on the best approach.
- **Address mold.** If you have mold, your contractor may advise you to gut the walls to expose the foundation. The moisture-damaged wood, damp insulation, and wallboard must all be removed. Save nothing! Mold spores are hard to kill and, if given enough moisture, can become a problem later. After the foundation is

Figure 5.15. Air leakage behind framed basement walls. Air leakage in an insulated basement allows moisture to condense behind insulation, reducing the effectiveness of the insulation and leading to mold (Source: BSC).





Spray foam was used in the rim joists and rigid foam was used on the inside walls of this basement remodel near Pittsburgh, Pennsylvania (Photo Source: Asdal Construction).

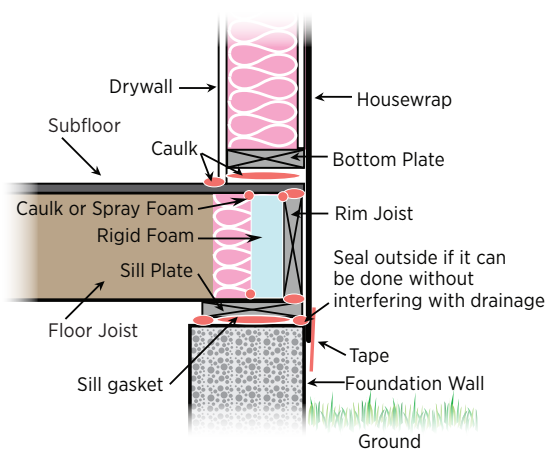


Figure 5.16. Insulating rim joists. Insulate and air seal the rim joist with closed-cell spray foam or pieces of rigid foam that are cut to fit each joist bay and sealed in place along all edges with caulk or spray foam.

For additional information on Air Sealing

Building America's Air Sealing Guide at http://apps1.eere.energy.gov/buildings/publications/pdfs/building_america/ba_airsealing_report.pdf.)

exposed, clean it thoroughly. The U.S. Environmental Protection Agency recommends using detergent and water (EPA 2010a) and recommends against using chlorine bleach or other biocides, because they can be health hazards themselves (EPA 2010b). Remove all the dust and dirt; these are food sources for mold.

- **Dry and waterproof.** The foundation should be thoroughly dry before your work begins. This is a good time to put a damproof coating on the foundation exterior (Lstiburek 2006b).

Air Seal

- **Air seal the attic floor.** Oddly enough, air sealing your attic floor will help reduce moisture problems in your basement (and your whole house). This is because of the stack effect, in which air rises inside a home the way it does in a chimney. If air can escape into the attic, replacement air will be pulled into your basement from outside. In most climates, the incoming air carries moisture. Air sealing the attic floor will stop the escape of air into the attic. This reduces the stack effect, so less moist air will be pulled into your basement.
- **Air seal the basement ceiling.** All holes and cracks in the basement ceiling should be sealed. If the subfloor plywood panels are accessible, those seams should be sealed as well.
- **Seal the foundation.** Seal air leaks where the sill plate meets the foundation. Check the foundation for cracks and holes and seal them.
- **Seal Ductwork.** Make sure any ductwork in the basement is sealed with mastic.

Seal and Insulate the Rim Joists

- Also called a band joist, the rim joist is the horizontal beam that rests on the sill plate, a 2 x 6 that sits horizontally on top of the foundation wall. Air can leak through multiple seams and holes where the rim joist meets the wall, the sill plate, and the subfloor. The rim joist should be air sealed and insulated to the same R-value as the walls. The best moisture control is achieved by filling the cavities where the floor joists meet the rim joist with spray foam insulation. Rigid fiberglass or rigid foam are also options, using caulk or spray foam to seal the edges (Saturn 2011; Yost and Lstiburek 2002). Rim joist air sealing is especially important at bump-out areas such as bay windows that extend beyond the foundation. Note: Do NOT install fiberglass batts in the rim joist cavities without air sealing first.

Final Steps

- **Check for radon.** If a test shows that radon is a concern, your contractor will need to install a radon mitigation system before proceeding any further. Radon causes lung cancer. For more information, see Chapter 4, “Safety and Health.” When the insulation project is complete, your contractor should check for radon again, since radon can become concentrated once the basement is air-sealed.
- **Insulate the basement floor,** if that will be of value in your climate. See Chapter 5.6, “Insulating Concrete Floors.”

5.5.4 Installing Insulation on the Interior of Basement Walls

Spray Foam Insulation

After preparing the basement as described above, your contractor should perform the following steps to install spray foam:

- Apply the foam directly to the foundation walls, thickly enough to reach the recommended R-value for your climate.
- Cover the foam with an ignition-barrier paint if you do not intend to cover the walls with framing and gypsum, which serves as an ignition barrier.

Alternatively, steel-stud framing can be embedded in the foam. Your contractor should:

- First construct a steel-stud wall 2 inches away from the foundation. (The space allows complete foam coverage of the wall and reduces thermal bridging.)
- Spray the foam directly on the entire surface of the masonry at a thickness of 2 to 4 inches.
- Attach ½-inch unfaced gypsum board to the stud wall as an ignition barrier for fire safety. The gypsum board should be at least ½-inch off the floor. It can be covered with latex paint.

Interior Rigid Foam Insulation

After preparing the basement as described in Section 5.5.3, your contractor should perform the following steps to install rigid foam insulation:



Exterior insulation. At this new home, in Pittsburgh, workers install rigid insulation on the foundation and exterior walls. Rigid foam insulation can be installed on the walls of existing homes when the siding is removed. Insulating the foundation of an existing home is more difficult; it requires digging a trench down to the frost line (Photo Source: IBACOS).

Termites can tunnel through exterior foam insulation and make it a “highway” to reach wood framing. Where termites are a threat, check with local pest control officials before using exterior foam insulation.

- Attach the foam panels to the interior of the foundation walls with construction adhesive applied in a serpentine pattern.
- Make sure the panels are fully in contact with the foundation wall, with no gaps.
- When using two layers of foam, stagger the seams.
- Create airtight seals where the panels meet and where they join other materials. Use acrylic-latex caulk, foam sealant, or mastic (Straube 2007).

If the rigid foam provides enough R-value, your contractor should:

- Attach wood furring strips to the foam to create an airspace and/or a nailer for the wall finish material.
- Attach ½-inch unfaced gypsum board to the furring strips, keeping the gypsum board at least ½-inch off the floor. It can be covered with latex paint.

If you need more R-value than the rigid foam provides, your contractor should:

- Construct stud framing of metal or wood, attached to the foam panels. Wood should not touch the concrete floor.
- Fill the stud cavities with unfaced fiberglass batts, damp spray cellulose, or spray fiberglass (Smegal and Straube 2010).
- Attach ½-inch unfaced gypsum board to the framing, keeping the gypsum board at least ½-inch off the floor. It can be covered with latex paint.

5.5.5 Installing Insulation on the Exterior of Basement Walls

Where termites are a threat, exterior foundation foam insulation is not recommended. The insulation can become a “highway” for termites to reach wood framing. Boric acid can be added to foam insulation to discourage termites, but the chemical is likely to leach out over time (Kriger and Dorsi 2009). Check with local pest control officials before planning to install exterior foundation insulation.

Either rigid fiberglass or XPS foam insulation can be used on the exterior of basement walls. To install the insulation, your contractor should take the following steps:

- Locate any utility lines.
- Excavate around the foundation to a depth of at least 2 feet. In cold climates, go down to the frost line.
- Damp-proof the foundation.
- Install a protective shield, such as metal flashing, between the top of the foundation wall and the sill plate to keep water from wicking into the foundation. It also serves as a termite shield.
- Install enough insulation to meet the recommended R-value for your climate, following the manufacturer's instructions.
- Protect foam insulation from ultraviolet light, moisture, and mechanical damage during installation and afterwards.

Proprietary Rigid Foam Board Systems

Several companies make specialty foam board systems for exterior basement insulation. While they can be more effective and faster to install than ordinary foam panels, they still require excavation, special coverings, and flashing measures.

5.5.6 Installing Insulation on the Basement Ceiling

Insulating the ceiling of your basement instead of the walls is recommended only when ALL of the following are true:

- You live in a dry climate, and
- you see no evidence of moisture in your basement, and
- you do not use your basement as living space.

Before beginning your insulation project, your contractor should complete the following steps:

- Replace any knob-and-tube wiring on the basement ceiling. It can overheat, creating a fire risk when covered with insulation.
- Make sure the basement has adequate ventilation.
- Make sure any pipes and ducts in the basement are well insulated against freezing and heat loss. Your basement will be colder when the ceiling is insulated. (Appendix C provides information on insulating ducts and hot water heaters.)



Basement ceiling insulation. When this home was remodeled for energy efficiency, the basement ceiling was extensively air sealed and then insulated with unfaced batts (Photo Source: PNNL).

See Appendix C for performance briefs on

- Air sealing ducts
- Insulating hot water heaters.

Profile

Design Challenge: Converting a Cold, Wet Basement into Useable Space

Building Science Corporation (BSC), a Building America research partner, helped launch the National Grid Deep Energy Retrofit Pilot in 2010. The first project involved the renovation of a Cape Cod-style home in Belchertown, Massachusetts, built in 1760.

One challenge was the cold, damp basement. It often contained standing—and sometime flowing—water. With advice from BSC, the homeowners worked with the builders to transform the basement into dry space for storage. They dug trenches in the basement, installed drainage piping, and laid down several cubic yards of gravel. They covered the gravel with sheet polyethylene to control vapor and block the entry of soil gases. The conversion to a dry, temperate basement was completed with an insulated concrete slab over the polyethylene sheet and the addition of spray foam insulation on the foundation walls.

- Air seal the basement ceiling to prevent soil gases, dust, and pollutants from moving up and into your home. Plug leaks in the rim joists and seal all plumbing, electrical, service, and duct penetrations. For details, see Appendix C. See also Building America's Air Sealing Guide at http://apps1.eere.energy.gov/buildings/publications/pdfs/building_america/ba_airsealing_report.pdf

You have several insulation choices for your basement ceiling:

- Spray foam can be applied, achieving air sealing and insulation in one step.
- Rigid insulation or netting can be attached to the underside of the floor trusses. The space should be filled with blown fiberglass or cellulose.
- Unfaced batt insulation can be installed between the floor joists.

To install batt insulation, your contractor should do the following:

- Install the unfaced batts in full contact with the joists and the floor above.
- Seal all seams carefully.
- Support the insulation with mechanical fasteners or inexpensive landscape cloth.
- Check to be sure there is no airspace between the insulation and the floor.
- Weather-strip the basement door.

5.5.7 Maintaining a Dry, Problem-free Basement

When your project is complete, you should take the following steps to ensure a healthy environment:

- Test again for radon. Radon levels can rise when the basement is air-sealed.
- Avoid using vinyl flooring or vinyl wallpaper in the basement. These are Class I vapor retarders and create a risk of mold.
- Use only latex paint, not oil, alkyd, or epoxy paint, which can hold moisture inside the wall.
- Keep storage items on shelves, off the floor, and allow for air circulation between the items and the wall.

Finally, you should monitor your basement to make sure it stays dry:

- Measure your basement's relative humidity in both winter and summer. According to the U.S. Environmental Protection Agency, the ideal humidity is 30% to 50%. Higher humidity can promote dust mites and mold (EPA 2010a).
- Install a dehumidifier if your basement's humidity exceeds 60%. Look for models with an ENERGY STAR seal. The dehumidifier should be plumbed directly to a condensate drain (Lstiburek 2006b).

5.6 Insulating Concrete Floors

Insulating a concrete floor can do more than reduce heat loss. Done properly, it can help solve moisture problems, making your home healthier, more comfortable, and more durable.

Concrete floors don't always need insulation. In hot climates, a cool floor is an advantage in summer. In other climates, however, the concrete floor of a basement or a home with a slab-on-grade foundation may be cold and uncomfortable in winter. Moisture may collect on the floor, creating an inviting place for mold and dust mites and leading to structural damage in the long term. The moisture can come from two sources:

- **CONDENSATION.** Moist indoor air can condense when it contacts cold concrete, making your carpet damp and musty. If you have a vinyl floor over concrete, it may be hiding mold.
- **GROUND MOISTURE.** Moisture in the ground may be wicking up through the concrete if there is no polyethylene vapor retarder under the slab. The floor may appear to be dry, but only because ground moisture passing through the slab is diffusing into the air.

Your concrete floor may also be wasting your energy dollars. Although little heat is lost through the floor of a deep basement, as much as 20% of a home's heat may be lost through a ground-level slab (DOE 2000c).

The subsections below provide guidance on two approaches to insulating a concrete floor:

- insulating the surface of a concrete floor
- insulating the exterior perimeter of a ground-level slab.

Be sure to hire a contractor certified in building science. A knowledgeable contractor can help you determine the best approach for your home, and expert installation is the key to a good outcome.

Figure 5.17. Insulating concrete floors.

If your existing concrete floor is dry and in good repair, an epoxy coating can be brushed onto the concrete. XPS insulation can then be installed directly over the surface (Figure Source: BSC).

Vapor semi-permeable assembly allows moisture to pass in a slow, controlled manner

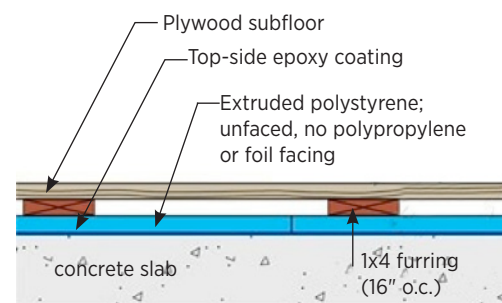
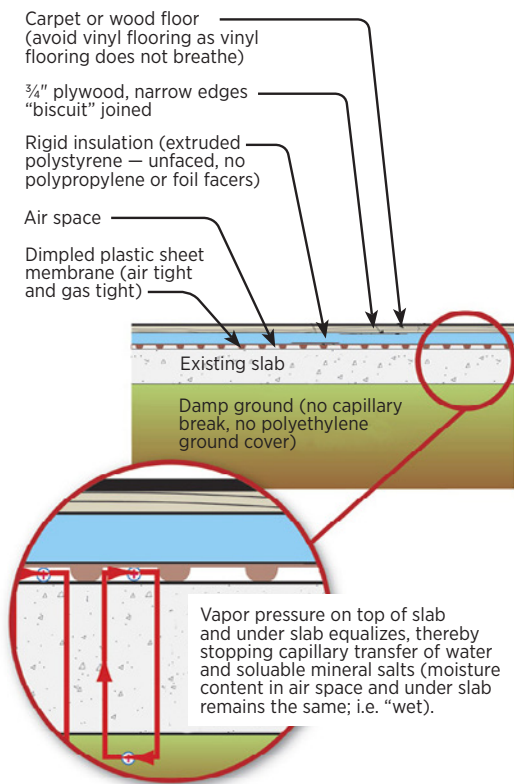


Figure 5.18. Vapor pressure equalization.

“An airspace is provided over the top of a wet concrete slab. This airspace is bounded by a vapor impermeable chamber (outward evaporation is not possible) and equilibrates with the slab. The vapor pressure in the airspace tracks the vapor pressure in the slab and stasis is achieved.” (Quote and Figure Source: Lstiburek 2008a)



5.6.1 Insulating the Surface of a Concrete Floor

Your contractor should take the following steps to insulate the surface of your concrete floor:

Prepare to Insulate

- Make sure adequate clearance will remain between the new floor and ceiling per local code (for example, 7.5 feet). Adding insulation and installing a new floor over the existing concrete will raise the height of the floor.
- Make sure any interior drainage system works well or install one if needed.
- Fix any sources of water intrusion. Make sure rain and groundwater drain away from the foundation. Make sure no sprinklers spray the foundation or wet the ground next to it. Fix plumbing leaks. If you can't remove all sources of water, don't insulate.
- Make sure the floor is clean and fix any problems in the concrete such as cracks, spalls, and water problems.

Control Moisture if the Concrete Appears Wet

Use one of the following moisture control measures when the concrete is visibly wet or where chalk-like salts (called efflorescence) are visible:

- Install a drainage mat directly over the concrete. A drainage mat works by moving water laterally to the interior drainage system.
- Alternatively, install a dimpled plastic sheet membrane, using cement to attach it to the concrete (see Figure 5.18). A dimpled membrane provides an air space over the wet concrete slab. The vapor pressure in the air space equalizes the vapor pressure in the slab. As a result, the concrete will not wick water up to the surface (Lstiburek 2008a).

Seal the Concrete if it Appears Dry

- Use an epoxy coating or chemical sealant (Figure 5.11). Any moisture wicked up by the concrete will pass through the floor and diffuse into the interior of the home in a slow, controlled manner without inviting mold growth.

Install Insulation

- Place extruded polystyrene rigid foam insulation (XPS) directly over epoxy-covered concrete, drainage mat, or dimpled membrane.
- Seal the joints between the foam panels with tape. Seal the edges along the walls with spray foam.
- Since XPS is a vapor retarder, there is no need to install another vapor retarder.

Install the New Floor

- Float a subfloor, using pressure-grooved sleepers or tongue-and-groove plywood.

Finish the Floor

- Install carpet or wood flooring to finish the floor.
- Do not install vinyl flooring. It will trap moisture, leading to mold and mildew.

Finish the Room

- Trim the bottom of any doors leading into the room to match the new floor height.
- Adjust the steps leading into the space, as raising the floor can create an unequal step on stairs.

5.6.3 Insulating the Perimeter of a Slab

A ground-level slab can be insulated on the perimeter instead of its surface or subsurface. The approach is effective because slabs primarily lose heat outward and through the edge of the slab. The concrete floor absorbs heat from inside the home and transfers it to the foundation wall, where it escapes outside.

Slab perimeter insulation is not appropriate for every climate zone. Building America scientists make the following recommendations (DOE 2004a):

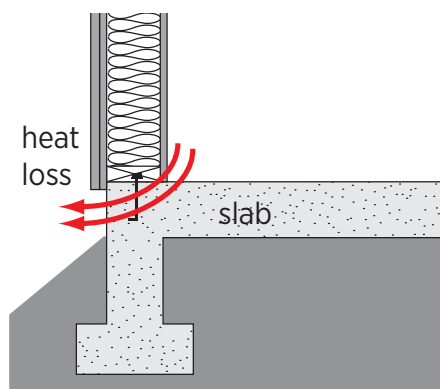
- **HOT-DRY:** Slabs in this climate do not require insulation.
- **MIXED-DRY:** In the absence of insulation below or above the slab surface, slabs in this climate should be insulated at the perimeter with borate-treated rigid foam or rigid fiberglass.



Moisture control. A dimpled plastic membrane can be placed over the existing concrete and under the XPS to keep your concrete floor from wicking ground water into your home (Photo source: BSC).

To identify your climate zone, see the map in Chapter 2.

Figure 5.19. Heat loss. Concrete slabs primarily lose heat outward and through the edge of the slab. In cold climates, insulating the slab perimeter can reduce heating bills by 10% to 20% (Source: DOE).



- **HOT-HUMID:** Slabs in this climate are generally not insulated, even at the perimeter, because of mild winters and code restrictions on below-grade use of rigid foam insulation.
- **MIXED HUMID:** In the absence of insulation below or above the slab surface, slabs in this climate should be insulated at the perimeter with borate-treated rigid foam or rigid fiberglass, unless prohibited by local code due to termite concerns.
- **COLD OR VERY COLD:** Insulating the surface of the slab is a more effective choice in these climates. When that is not feasible, perimeter insulation can be valuable.

To identify your climate zone, see the IECC map in Chapter 2.

Slab Perimeter Insulation: Advantages and Drawbacks

Where recommended, insulating the exterior edge of the slab can reduce winter heating bills by 10% to 20% (DOE 2011e). It can also reduce moisture problems, since a warmer slab is less prone to condensation.

On the other hand, several factors may make slab perimeter insulation unfeasible for your home. It is expensive. To install the insulation, your contractor will need to dig a trench around your house to the depth of the frost line. A driveway, sidewalk, or trees may be in the way. Where termites are a risk, your local building codes may not allow you to insulate the slab perimeter with rigid foam. Termites can tunnel through foam to reach wood framing. Rigid fiberglass is an alternative.

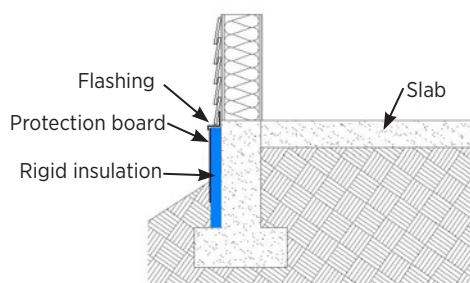
To insulate the perimeter of your concrete slab, your contractor should take the following steps:

Prepare to Insulate

- Review the plans with pest control officials as well as building officials.
- Check that the lot is graded properly so that rain and groundwater don't run into the foundation. Make sure the sprinklers don't spray the foundation or wet the ground next to it.
- Install a perimeter drainage system if needed or check that an existing system is working well.
- Check for radon, which causes cancer. If the radon level is elevated, you will need to install an appropriate radon mitigation system. (See Chapter 4, Safety and Health.)

Figure 5.20. Slab perimeter insulation.

Use rigid fiberglass insulation or borate-treated rigid foam approved for below-grade use (Source: DOE).



Dig a Trench and Waterproof

- Dig a trench around the house to the depth prescribed by your local building codes. In areas where the ground freezes, the minimum depth will be the frost line.
- Clean the foundation and allow it to dry.
- Apply a waterproof coating.

Install Insulation

- Use rigid fiberglass insulation or borate-treated rigid foam approved for below-grade use. Foam insulation must be protected from ultraviolet light, moisture, and mechanical damage during installation and afterwards.
- Install flashing or protective board over the insulation.
- Install insulation directly against the slab's exterior edges, extending it from the top of the slab to the depth of the frost line. Local building codes may require a termite inspection gap between the sill plate and the top of the insulation.
- Follow the manufacturer's instructions for attaching the insulation.
- Air seal all edges. The insulation should be continuous and airtight.
- Air-seal the interface between the foundation and the exterior wall.

Install a Protective Membrane

- Encapsulate or cover the exterior face of the insulation with a protective membrane, such as rubberized roofing material or an ice-dam protection membrane. This will serve as a capillary break to reduce the wicking of water from the foundation. This membrane can also serve as a termite shield.

Cover Above-grade Insulation

- Cover the portion of the insulation exposed to the outside air with a stucco coating, pressure-treated wood, brick, or aluminum flashing.

Finish and Test

- Replace the dirt around the perimeter.
- Check again for radon, since insulation can lead to concentrated radon levels inside the home.

Once the project is complete, be sure to inspect your home regularly for termite infestation.



(Top) Mastic is a thick, gooey substance that is painted onto seams and joints. Duct seams and joints should be sealed with mastic or approved metal tape, not duct tape (Photo Source: FSEC).

(Bottom) Ducts should be inspected to make sure they aren't crushed, sagging, leaking, or disconnected, a surprisingly common finding during duct inspections (Photo Source: BSC).

5.7 Insulating Ducts

As much as 40% of the energy used to heat and cool your home can be lost by leaky, poorly insulated ducts that run through unconditioned parts of your home, such as the attic or crawlspace (LBNL 2001). This can add hundreds of dollars a year to your heating and cooling bills (DOE 2009). Your heating and cooling equipment has to work harder, and some rooms may be colder in winter because of heat loss through conduction along the ducts and from air leaks at seams and joints, such as where branches meet a trunk line, where the ducts meet the registers, and where the ducts are connected to the furnace or air conditioner. About half of typical energy loss from ducts is due to air leaks (LBNL 2001). Even ducts in conditioned space can have lose energy through uninsulated ducts and air leaks that waste conditioned air and cause pressure imbalances between rooms and inadequate air flow to parts of the home. Ducts should be airtight and insulated not only for comfort and energy savings but to prevent condensation and mold. Mold can grow on moisture and dirt collecting inside ducts, and the air moving through the ducts will distribute the spores through the home.

Ducts in older homes are usually made from sheet metal and may or may not have added insulation. Newer homes often have ducts made of fiberglass duct board or flexible plastic, both of which have built-in insulation. If your ducts are already insulated, adding insulation is recommended if the R-value is less than 4.2 (LBNL 2003). The International Energy Conservation Code recommends that supply ducts in attics be insulated to a minimum of R-8 and other ducts be insulated to a minimum of R-6, although it does not have a minimum requirement for ducts that are completely within the building's thermal envelope (2009 IECC 403.2.1). Supply ducts in conditioned space should be insulated to avoid condensation on the inside of the duct in summer and the outside in winter. Exhaust ducts going through cold spaces in the winter should also be insulated to avoid condensation inside (Rudd 2009).

Before insulation is added, the ducts should be tested for air leaks. Air leaks are tested with a duct test, which is often done as part of a whole-house energy checkup or audit (see Chapter 2). The IECC recommends total duct leakage of less than or equal to 12 cfm per 100 ft² of conditioned floor area when tested at 25 Pascals (2009 IECC 403.2.2).

Because ducts are often concealed in walls, ceiling, attics, and basements, repairing them can be difficult. Get a qualified professional to seal and insulate them. In addition to the duct blaster test, the contractor should visually inspect the duct system, evaluate the system's supply and return air balance, and check air flow at each register. Adjustments such as larger return ducts may be needed.

The contractor will replace damaged ducts, reconnect disconnected ducts with mechanical fasteners, and straighten and tighten flexible ducts that are tangled, crushed, kinked, or sagging due to unnecessary length or lack of adequate hanging straps. Leaks and joints should be sealed with a long-lasting material such as mastic, a gooey substance that is “painted” on to seams and reinforced with wire mesh tape if needed (Rudd 2009). Butyl tape, foil tape, or other heat-approved tapes with the Underwriters Laboratories logo can also work well if the area to be taped is cleaned of surface dust and dirt first. Plastic or cloth duct tape should not be used because it dries, cracks, and quickly loses its bond. Pressure- or heat-sensitive aluminum foil tape is recommended if a joint needs to be accessible for future maintenance. The contractor will use caulk to seal all registers and grills tightly to the ducts.

Once the ducts are sealed, they should be covered with fiberglass duct insulation that has a foil or vinyl facing on the exterior to keep the insulation dry. If you already have duct insulation that is wet, smelly, or visibly moldy, it should be removed and replaced by a qualified heating and cooling system contractor. If your ducts were made with a fiberglass duct liner, cleaning will not prevent re-growth. The material must be replaced (EPA 2011).

The ducts should be wrapped with foil- or vinyl-faced fiberglass duct insulation, with the vapor retarder facing out. The insulation should cover the duct completely. The facings should overlap where sections of insulation meet and they should be tightly sealed with fiberglass tape, applied carefully to avoid compressing the insulation. Compressed insulation loses R-value. The end of each piece of tape should point downward; tape pointing upward will eventually fall (Kriger and Dorsi 2009). Metal fasteners may also be added.

Upon completion of the work, your contractor will evaluate air flow and conduct a combustion safety test to be sure there is no backdrafting of gas- or oil-burning appliances.

When you insulate ducts in an unconditioned basement or crawlspace, that space will be colder. Water pipes and drains located there may freeze and burst if you live in a cold climate. Consider insulating the basement walls or closing and insulating the crawlspace. Both projects can have significant benefits for your health, comfort, and energy savings. If your renovation project includes replacing the furnace and ducts, consider installing a high-efficiency, sealed-combustion furnace and insulated ducts within the thermal envelope of the home. You may also want to consider going ductless with ductless heat pumps.



All ducts should be laid straight and adequately supported. Flex ducts should be stretched tightly; loose, sagging ducts can greatly restrict air flow (Photo Source: PNNL).

References

- Advanced Energy. 2011. *Closed Crawl Spaces: Top Performers Nationwide*. Accessed 10-22-11. www.advancedenergy.org/buildings/knowledge_library/crawl_spaces/pdfs/Closed%20Crawl%20Spaces_04.22.09.pdf
- AWCI. 1994. "Rutgers University Gives EIFS Retrofit an 'A' Grade," *Construction Dimensions*, Association of the Wall and Ceiling Industry. www.awci.org/cd/pdfs/9402_c.pdf
- Baker, Ken, and Chuck Murray. 2006. *CrawlSpace Issues in the Northwest*. Washington State University Extension Energy Program. www.kenergy.us/pdf/Regional%20CrawlSpace_final.pdf
- Briggs, R.S., R.G. Lucas, and Z.T. Taylor. 2003. "Climate Classification for Building Energy Codes and Standards: Part 2 - Zone Definitions, Maps and Comparisons," *Technical and Symposium Papers, ASHRAE Winter Meeting*, Chicago, January 2003.
- Building Energy Codes Resource Center. 2011a. *Conditioned Attics - Code Notes*, Article #1520. Pacific Northwest National Laboratory. <http://resourcecenter.pnl.gov/cocoon/morf/ResourceCenter/article/1520>
- Building Energy Codes Resource Center. 2011b. *Details for Mechanically Vented Crawlspaces - Code Notes*, Article #131. Pacific Northwest National Laboratory. <http://resourcecenter.pnl.gov/cocoon/morf/ResourceCenter/article//131>
- BSC. 2009a. *Basement Insulation*, IS-511. www.buildingscience.com/documents/information-sheets/basement-insulation
- BSC. 2009b. *CrawlSpace Insulation*, IS-512, Building Science Corporation. www.buildingscience.com/documents/information-sheets/crawlSpace-insulation/?searchterm=sheet%20512
- BSC. 2011. *National Grid Deep Energy Retrofit Pilot Program—Millbury Cape*, Building Science Corporation. www.buildingscience.com/documents/case-studies/cold-climate-national-grid-deep-energy-retrofit-millbury-cape/?searchterm=retrofit%20case%20study
- City of Portland. 2011. *Home Insulation 101*. Bureau of Planning and Sustainability, City of Portland, Oregon. www.portlandonline.com/bps/index.cfm?a=116025&c=42115
- Dastur, Cyrus and Bruce Davis. 2005. "Closed Crawlspaces Do Double Duty," *Home Energy Magazine*, January 2005. www.advancedenergy.org/buildings/knowledge_library/crawl_spaces/pdfs/Home%20Energy%20January%202005_low%20res2.pdf
- DOE. 2000a. *Attic Access Technology Fact Sheet*. Prepared by Southface Energy Institute and Oak Ridge National Laboratory, for U.S. Department of Energy. www.ornl.gov/sci/roofs+walls/insulation/fact%20sheets/attic%20access.pdf
- DOE. 2000b. *Ceilings and Attics Technology Fact Sheet*. Prepared by Southface Energy Institute and Oak Ridge National Laboratory, for U.S. Department of Energy. www.ornl.gov/sci/roofs+walls/insulation/fact%20sheets/attic%20floors.pdf
- DOE. 2000c. *Slab Insulation Technology Fact Sheet*. Prepared by Southface Energy Institute and Oak Ridge National Laboratory, for U.S. Department of Energy. www.ornl.gov/sci/roofs+walls/insulation/fact%20sheets/slab%20insulation%20technology.pdf
- DOE. 2002. *Basement Insulation Technology Fact Sheet*. Prepared by Southface Energy Institute and Oak Ridge National Laboratory, for U.S. Department of Energy. http://apps1.eere.energy.gov/buildings/publications/pdfs/building_america/26455.pdf
- DOE. 2003a. *An Introduction to Residential Duct Systems*. Prepared by the Lawrence Berkeley National Laboratory, for U.S. Department of Energy. <http://ducts.lbl.gov/>
- DOE. 2003b. *Thermal Performance of Unvented Attics in Hot-Dry Climates: Results from Building America*. Prepared by the National Renewable Energy Laboratory, for U.S. Department of Energy. www.nrel.gov/docs/fy03osti/32827.pdf
- DOE. 2004a. *Introduction to Building Systems Performance: Houses That Work II*. Prepared by Building Science Corporation, for U.S. Department of Energy. www.nrel.gov/docs/fy04osti/34585.pdf
- DOE. 2004b. *Retrofit Best Practices Guide*. Prepared by Oak Ridge National Laboratory, for U.S. Department of Energy. www.ornl.gov/sci/roofs+walls/facts/RetrofitBestPractices/homeownerguide15b1.pdf
- DOE. 2007a. *Highlights: Energy Codes 2007*, Building Energy Codes Program: Setting the Standard. U.S. Department of Energy. www.energycodes.gov/publications/STS/2007/standard_november07.pdf
- DOE. 2007b. *Renovating Your Basement*, RR-0308. Prepared by Building Science Corporation, for U.S. Department of Energy. www.buildingscience.com/documents/reports/rr-0309-renovating-your-basement
- DOE. 2008b. *Insulation Fact Sheet*. DOE/CE-0180. Prepared by Oak Ridge National Laboratory for U.S. Department of Energy. www.ornl.gov/sci/roofs+walls/insulation/ins_01.html,
- DOE. 2009. *Energy Savers Booklet*. U.S. Department of Energy, www.eere.energy.gov/consumer/tips/m/ducts.html
- DOE. 2009a. *Case Study: Green Home Solutions by Grupe*, Lodi, CA. Prepared by the Pacific Northwest National Laboratory, for U.S. Department of Energy. http://apps1.eere.energy.gov/buildings/publications/pdfs/building_america/ba_cs_retrofit_green_home_solutions.pdf

- DOE. 2009b. *Comprehensive Energy Retrofit Case Study: Yakama Nation Housing Authority Wapato, WA*. Prepared by the Pacific Northwest National Laboratory, for U.S. Department of Energy. http://apps1.eere.energy.gov/buildings/publications/pdfs/building_america/ba_cs_retrofit_yakama.pdf
- DOE. 2009c. "Cool Down with 'Reflective Insulation' Materials." *Setting the Standard*. Prepared by the Pacific Northwest National Laboratory, for U.S. Department of Energy. www.energycodes.gov/publications/STS/2009/standard_january09.pdf
- DOE. 2009d. *Energy Savers Booklet*. U.S. Department of Energy. www.energysavers.gov/pdfs/energy_savers.pdf
- DOE. 2009e. *High Performance Builder Spotlight: ReVISION Home, Las Vegas, Nevada*, Prepared by the Pacific Northwest National Laboratory, for U.S. Department of Energy. www.eere.energy.gov/buildings/challenge/pdfs/ba_builderschallengespotlight.pdf
- DOE. 2010a. *Air Sealing: A Guide for Contractors to Share with Homeowners*. Prepared by the Pacific Northwest National Laboratory and Oak Ridge National Laboratory, for U.S. Department of Energy. http://apps1.eere.energy.gov/buildings/publications/pdfs/building_america/ba_airsealing_report.pdf
- DOE. 2010b. *Builders Challenge Guide to 40% Whole-House Energy Savings in the Hot-Dry and Mixed-Dry Climates*. Prepared by the Pacific Northwest National Laboratory and Oak Ridge National Laboratory, for U.S. Department of Energy. http://apps1.eere.energy.gov/buildings/publications/pdfs/building_america/18899.pdf
- DOE. 2010c. *Builders Challenge Guide to 40% Whole-House Energy Savings in the Marine Climate*. Prepared by the Pacific Northwest National Laboratory and Oak Ridge National Laboratory, for U.S. Department of Energy. http://apps1.eere.energy.gov/buildings/publications/pdfs/building_america/marine_40_guide.pdf
- DOE. 2010d. *Crawlspace Design in Marine and Cold Climates*. U.S. Department of Energy. www.ornl.gov/sci/buildings/2010/Session%20PDFs/96_New.pdf
- DOE. 2010e. "Recommended Design and Construction Details: Vented Versus Unvented Crawl Spaces," *Building Foundations Design Handbook (Draft)*. Prepared by Oak Ridge National Laboratory, for U.S. Department of Energy. www.ornl.gov/sci/buildingsfoundations/handbook/section3-2.shtml
- DOE. 2011a. *Building America Best Practices Series, Volumes 1-9*. Prepared by the Pacific Northwest National Laboratory and Oak Ridge National Laboratory, for U.S. Department of Energy. www.eere.energy.gov/buildings/building_america/climate_specific_publications.html
- DOE. 2011b. *Building America – Resources for Energy Efficient Homes*. U.S. Department of Energy. www.eere.energy.gov/buildings/building_america/program_goals.html
- DOE. 2011c. *Energy Savers: Your Home - Insulation*. U.S. Department of Energy. www.energysavers.gov/your_home/insulation_airsealing/index.cfm/mytopic=11590
- DOE. 2011d. *Energy Savers: Vapor Barriers or Vapor Diffusion Retarders*. U.S. Department of Energy. www.energysavers.gov/your_home/insulation_airsealing/index.cfm/mytopic=11810
- DOE. 2011e. *Slab on Grade Foundation Insulation*. U.S. Department of Energy. Accessed 10/20/2011. www.energysavers.gov/your_home/insulation_airsealing/index.cfm/mytopic=11490
- DOE. 2011f. *Building America's Deep Energy Retrofit Research Project: Case Study: 1970s Split-Entry Home, Richland, WA*. PNNL-SA-83162, Prepared by Pacific Northwest National Laboratory, for U.S. Department of Energy Building America, www.buildingamerica.gov
- Ellringer, P. 2002. "Minnesota Mold Busting," *Home Energy Magazine*, June 2002. www.homeenergy.org
- EPA. 2006. *Indoor airPLUS Construction Specifications*. U.S. Environmental Protection Agency. www.epa.gov/iaplus01/construction_specifications.html
- EPA. 2010a. *A Brief Guide to Mold, Moisture, and Your Home*. U.S. Environmental Protection Agency. www.epa.gov/mold/moldguide.html
- EPA. 2010b. *Mold Remediation in Schools and Commercial Buildings*. U.S. Environmental Protection Agency. www.epa.gov/iedmold1/i-e-r.html#Mold%20Remediation/Cleanup%20and%20Biocides
- EPA. 2011. "Should you have the air ducts in your home cleaned?" U.S. Environmental Protection Agency, <http://epa.gov/iaq/pubs/airduct.html>
- EPA. 2011a. *ENERGY STAR: Guidelines for Home Energy Upgrade Professionals*. U.S. Environmental Protection Agency. www.eere.energy.gov/wip/retrofit_guidelines_overview.html
- EPA. 2011b. *ENERGY STAR: Methodology for Estimated Energy Savings from Cost-Effective Air Sealing and Insulating*. U.S. Environmental Protection Agency. Accessed 9/4/11. www.energystar.gov/index.cfm?c=home_sealing.hm_improvement_methodology
- EPA. 2011c. *Healthy Indoor Environment Protocols for Home Energy Upgrades*. U.S. Environmental Protection Agency. www.epa.gov/iaq/homes/retrofits.html

- EPA. 2011d. *Home Performance with ENERGY STAR*. U.S. Environmental Protection Agency. Accessed 9/4/11.
www.energystar.gov/index.cfm?fuseaction=hpwes_profiles.showSplash
- EPA. 2011e. *Radon: Health Risks*. U.S. Environmental Protection Agency.
www.epa.gov/radon/healthrisks.html
- Fugler, Don. 2002. "Dry Notes from the Underground," *Home Energy Magazine*, April 2002.
www.bestofbuildingscience.com/pdf/Dry%20Notes%20from%20the%20underground%20HEM_19-2_p18-22.pdf
- Hales, David. 2011. "The SCARY Crawl Space," *Home Energy Magazine*, January/February 2011.
www.homeenergy.org/show/article/nav/indoorairquality/id/776
- Halverson, M.A., B. Shui, and M. Evans. 2009. *Country Report on Building Energy Codes in the United States*, PNNL-17979. Prepared by the Pacific Northwest National Laboratory for the U.S. Department of Energy.
www.pnl.gov/main/publications/external/technical_reports/PNNL-17979.pdf
- Katz, Arnie 2011. "Attic Ventilation," Buildings – Knowledge Library, Advanced Energy. Accessed 9-4-11.
www.advancedenergy.org/buildings/knowledge_library/ventilation/attic_ventilation.html
- Krigger, John and Chris Dorsi. 2009. *Residential Energy*. Helena, Montana: Saturn Resource Management Inc..
- LBNL. 2001. "California's Duct Opportunity," Lawrence Berkeley National Laboratory, <http://ducts.lbl.gov/calducts.htm#problem>
- LBNL. 2003. "An Introduction to Residential Duct Systems," Lawrence Berkeley National Laboratory, <http://ducts.lbl.gov/>
- Lstiburek, Joseph. 2003. *Renovating Your Basement*, RR-0309. Prepared for U.S. Department of Energy by Building Science Corporation. www.buildingscience.com/documents/reports/rr-0309-renovating-yourbasement
- Lstiburek, Joseph. 2004a. *Face-Sealed vs. Drainable EIFS*, RR-0406, Building Science Corporation.
www.buildingscience.com/documents/reports/rr-0406-face-sealed-drainable-eifs
- Lstiburek, Joseph. 2004b. *Insulations, Sheathings and Vapor Retarders*. RR-0412, Building Science Corporation.
www.buildingscience.com/documents/reports/rr-0412-insulations-sheathings-and-vapor-retarders/?topic=doctypes/researchreport
- Lstiburek, Joseph. 2004c. *Roof Design*, RR-0404, Building Science Corporation.
www.buildingscience.com/documents/reports/rr-0404-roof-design
- Lstiburek, Joseph. 2004d. *Vapor Barriers and Wall Design*, RR-0410, Building Science Corporation.
www.buildingscience.com/documents/reports/rr-0410-vapor-barriers-and-wall-design
- Lstiburek, Joseph. 2006a. *Conditioned Crawl Space Construction, Performance and Codes*. RR-0401, Building Science Corporation.
www.buildingscience.com/documents/reports/rr-0401-conditioned-crawl-space-construction-performance-and-codes/view
- Lstiburek, Joseph. 2006b. *READ THIS: Before You Design, Build or Renovate*. Prepared by Building Science Corporation for the U.S. Department of Energy. www.buildingscience.com/documents/guides-and-manuals/gm-read-this-before-you-design-build-reno-vate/view?topic=doctypes/guides-and-manuals
- Lstiburek, Joseph. 2006c. *Understanding Attic Ventilation*, BSD-102, Building Science Corporation.
www.buildingscience.com/documents/digests/bsd-102-understanding-attic-ventilation?topic=doctypes/digests
- Lstiburek, Joseph. 2006d. *Understanding Basements*, BSD-103, Building Science Corporation.
www.buildingscience.com/documents/digests/bsd-103-understanding-basements
- Lstiburek, Joseph. 2006e. *Understanding Vapor Barriers*, BSD-106, Building Science Corporation.
www.buildingscience.com/documents/digests/bsd-106-understanding-vapor-barriers
- Lstiburek, Joseph. 2007. *EIFS - Problems and Solutions*, BSD-146, Building Science Corporation.
www.buildingscience.com/documents/digests/bsd-146-eifs-problems-and-solutions
- Lstiburek, Joseph. 2008a. *Concrete Floor Problems*, BSI-003, Building Science Corporation.
<https://www.buildingscience.com/documents/insights/bsi-003-concrete-floor-problems>
- Lstiburek, Joseph. 2008b. *New Light in Crawlspace*, BSI-009, Building Science Corporation.
www.buildingscience.com/documents/insights/bsi-009-new-light-in-crawlspace/files/BSI-009_Crawlspace_2010r2.pdf
- Lstiburek, Joseph. 2009. *Energy Flow Across Enclosures*, BSI-028, Building Science Corporation.
www.buildingscience.com/documents/insights/bsi-028-energy-flow-across-enclosures
- Lstiburek, Joseph. 2010a. "Don't Be Dense – Cellulose and Dense-Pack Insulation," BSI-043, Building Science Corporation.
www.buildingscience.com/documents/insights/bsi-043-dont-be-dense?topic=resources/retrofits
- Lstiburek, Joseph. 2010b. *Guide to Attic Air Sealing*. Prepared by Building Science Corporation for U.S. Department of Energy.
www.buildingscience.com/documents/primers/guide-to-attic-air-sealing-with-details/?searchterm=air%20sealing

- Lstiburek, Joseph. 2011a. "A Crash Course in Roof Venting," *Fine Homebuilding*, The Taunton Press, Inc. www.finehomebuilding.com/how-to/articles/a-crash-course-in-roof-venting.aspx
- Lstiburek, Joseph. 2011b. *Dam Ice Dam*, BSI-046, Building Science Corporation. www.buildingscience.com/documents/insights/bsi-046-dam-ice-dam/?searchterm=roof%20snow%20load
- Malkin-Weber, Melissa, Jonathan Coulter, Tracy Dixon, Cyrus Dastur, and Bruce Davis. 2008. *Vented Crawlspace as Mold Amplification and Delivery Systems? Measured Performance and a Dry Alternative*, Advanced Energy www.advancedenergy.org/buildings/knowledge_library/crawl_spaces/pdfs/ASHRAE_IAQ_Paper.pdf
- National Park Service. 2011. "Weatherization: Install Insulation," National Park Service Technical Preservation Service, www.nps.gov/tps/sustainability/energy-efficiency/weatherization/install-insulation.htm
- NIH. 2009. "Final report on carcinogens background document for glass wool fibers. September 9, 2009." *National Center for Biotechnology Information*, National Institutes of Health. www.ncbi.nlm.nih.gov/pubmed/20737004
- NIH. 2011. "New substances added to HHS Report on Carcinogens," *10 Jun 2011: News Releases*, National Institutes of Health. www.niehs.nih.gov/news/releases/2011/roc/
- Parker, D.S., J. R. Sherwin and M. T. Anello. 2001. "FPC Residential Monitoring Project: New Technology Development – Radiant Barrier Pilot Project," FSEC-CR-1231-01, Florida Solar Energy Center. www.fsec.ucf.edu/en/publications/html/FSEC-CR-1231-01/index.htm
- Rudd, Armin. 2009. "Top Ten Issues in Residential Ventilation Design," BSI-016, Building Science Corporation, www.buildingscience.com/documents/insights/bsi-016-ventilation-top-ten-list
- Rudd, Armin, Joseph Lstiburek, P. Eng, and Kohta Ueno. 1999. *Unvented-cathedralized attics: Where we've been and where we're going*, RR-9904, Building Science Corporation. www.buildingscience.com/documents/reports/rr-9904-unvented-cathedralized-attics-where-we-ve-been-and-where-we-re-going
- Saturn Resource Management. 2011. "Basement Insulation," *Resources – Tips – Insulation and Air Sealing*. <http://blog.srmi.biz/energy-saving-tips/insulation-air-sealing/basement-insulation/>
- Smegal, Jonathan and John Straube. 2010. *Building America Special Research Project: High-R Foundations Case Study Analysis*, RR-1003. Prepared by Building Science Corporation for the U.S. Department of Energy. www.buildingscience.com/documents/reports/rr-1003-building-america-high-r-foundations-case-study-analysis
- Straube, John and Aaron Grin. 2010. *Building America Special Research Project: High-R Roofs Case Study Analysis*, RR-1006. Prepared by Building Science Corporation for the U.S. Department of Energy. www.buildingscience.com/documents/reports/rr-1006-building-america-special-research-project-high-r-roofs-case-study-analysis
- Straube, John and Jonathan Smegal. 2009. *Building America Special Research Project: High-R Walls Case Study Analysis*. Prepared by Building Science Corporation for the U.S. Department of Energy. www.buildingscience.com/documents/reports/rr-0903-building-america-special-research-project-high-r-walls
- Straube, John, Jonathan Smegal and John Smith. 2010. *Moisture-Safe Unvented Wood Roof Systems*, RR-1001, Building Science Corporation. www.buildingscience.com/documents/reports/rr-1001-moisture-safe-unvented-wood-roof-systems
- Straube, John. 2006. *Wood Pitched Roof Construction*, BSD-115, Building Science Corporation. www.buildingscience.com/documents/digests/bsd-115-wood-pitched-roof-construction?topic=doctypes/digests
- Straube, John. 2007. "Interior Insulation Retrofits of Load-Bearing Masonry Walls In Cold Climates," BSD-114, Building Science Corporation. www.buildingscience.com/documents/digests/bsd-114-interior-insulation-retrofits-of-load-bearing-masonry-walls-in-cold-climates/
- Straube, John. 2011. *Building America Special Research Project: High R-Value Enclosures for High Performance Residential Buildings in All Climate Zones*. Prepared by Building Science Corporation for the U.S. Department of Energy. www.buildingscience.com/documents/reports/rr-1005-building-america-high-r-value-high-performance-residential-buildings-all-climate-zones/view?searchterm=1005
- U.S. Department of Energy. 2011g. *Energy Savers: How Moisture Moves through a Home*. www.energysavers.gov/your_home/insulation_airsealing/index.cfm/mytopic=11760
- Ueno, Kohta. 2010. *Residential Exterior Wall Superinsulation Retrofit*, RR-1012, Building Science Corporation (rev. 2011). www.buildingscience.com/documents/reports/rr-1012-residential-exterior-wall-superinsulation-retrofit/view
- Yost, Nathan and Joseph Lstiburek. 2002. *Basement Insulation Systems*. Prepared by Building Science Corporation for the U.S. Department of Energy. www.eere.energy.gov/buildings/building_america/pdfs/db/35017.pdf

Photo Credits

- Building Science Corporation. 2009. *Mixed-Humid Climate: GreenCraft Greenspoint House Prototype*.
www.buildingscience.com/documents/case-studies/cs-tx-greencraft-greenspoint?topic=doctypes/designs-that-work/dtw-case-studies
- Building Science Corporation. 2010a. *Cold Climate: Bedford Farmhouse High Performance Retrofit Prototype*.
www.buildingscience.com/documents/case-studies/cold-climate-bedford-farmhouse-retrofit-case-study?topic=doctypes/designs-that-work/dtw-case-studies
- Building Science Corporation. 2010b. *Cold Climate: National Grid Deep Energy Retrofit Pilot Program—Clark Residence*.
www.buildingscience.com/documents/case-studies/cs-ma-ngrid-deep-energy-retrofit?topic=doctypes/designs-that-work/dtw-case-studies
- Building Science Corporation. 2010c. *Mixed-Humid Climate: GreenCraft Builders 2009 TimberCreek Net Zero Energy House Prototype*.
www.buildingscience.com/documents/case-studies/cs-tx-lewisville-greencraft?topic=doctypes/designs-that-work/dtw-case-studies
- Building Science Corporation. 2011. *National Grid Deep Energy Retrofit Pilot Program—Millbury Cape*. www.buildingscience.com/documents/case-studies/cold-climate-national-grid-deep-energy-retrofit-millbury-cape/?searchterm=retrofit%20case%20study
- Consortium for Advanced Residential Buildings. 2011. Cold Climate Region 40+% Energy Savings: Whitman “Welcome Home,” Accessed 9-15-2011. www.carb-swa.com/articles/builder%20projects/VeridianCaseStudy.pdf
- ENERGY STAR. 2008. “Sealing Air Leaks And Adding Attic Insulation,” A Do-It-Yourself Guide To Sealing and Insulating with ENERGY STAR®. www.energystar.gov/ia/partners/publications/pubdocs/DIY_Guide_May_2008.pdf
- Florida Solar Energy Center. 2009. *Preliminary Performance Evaluation of a Near Zero Energy Home in Callaway, Florida*.
www.fsec.ucf.edu/en/publications/pdf/FSEC-CR-1793-09.pdf
- Lstiburek, Joseph. 2006. *Understanding attic ventilation*. www.buildingscience.com/documents/digests/bsd-102-understanding-attic-ventilation/files/bsd-102_Understanding%20Attic%20Ventilation_rev.pdf
- Lstiburek, Joseph. 2008a. *Dam Ice Dam, Building Science Insights – 046*, Building Science Corporation.
www.buildingscience.com/documents/insights/bsi-046-dam-ice-dam/?searchterm=ice%20dams
- Lstiburek, Joseph. 2008b. *New Light In Crawlspace, Building Science Insights – 009*, Building Science Corporation.
www.buildingscience.com/documents/insights/bsi-009-new-light-in-crawlspace
- Lstiburek, Joseph. 2010. *Don't Be Dense, Building Science Insights – 043*. www.buildingscience.com/documents/insights/bsi-043-dont-be-dense/?searchterm=cathedral%20ceiling006-ba-high-r-roofs-case-study-analysis
- Pettit, Betsy. 2009. *Deep Energy Retrofit of a Sears Roebuck House—A Home for the Next 100 Years, Building Science Digests –139*, Building Science Corporation. www.buildingscience.com/documents/digests/bsd-139-deep-energy-retrofit-of-a-sears-roebuck-house-a-home-for-the-next-100-years
- Pettit, Betsy. 2010. *Cold Climate: Concord Four Square Retrofit*, Building Science Corporation.
www.buildingscience.com/documents/case-studies/cs-climate-concord-four-square-retrofit
- Straube, John. 2006. *Ice Dams, Building Science Digests – 135*.
www.buildingscience.com/documents/digests/bsd-135-ice-dams/?searchterm=ice%20dams
- U.S. Department of Energy 2009a. *Case Study: Chesapeake Habitat for Humanity, Baltimore, MD*.
http://apps1.eere.energy.gov/buildings/publications/pdfs/building_america/ba_cs_retrofit_chesapeake_habitat.pdf
- U.S. Department of Energy 2009b. *Case Study: Consortium for Advanced Residential Buildings (CARB) – Washington, D.C.*
http://apps1.eere.energy.gov/buildings/publications/pdfs/building_america/ba_cs_retrofit_carb.pdf
- U.S. Department of Energy 2009c. *Case Study: Green Home Solutions by Grupe, Lodi, CA*.
http://apps1.eere.energy.gov/buildings/publications/pdfs/building_america/ba_cs_retrofit_green_home_solutions.pdf
- U.S. Department of Energy 2009d. *Case Study: HartmanBaldwin Design/Build Pasadena, CA*.
http://apps1.eere.energy.gov/buildings/publications/pdfs/building_america/ba_cs_retrofit_hartman_baldwin.pdf
- U.S. Department of Energy 2009e. *Comprehensive Energy Retrofit Case Study: Yakama Nation Housing Authority Wapato, WA*.
http://apps1.eere.energy.gov/buildings/publications/pdfs/building_america/ba_cs_retrofit_yakama.pdf
- U.S. Department of Energy. 2010f. *Case Study: Devoted Builders, LLC*.
http://apps1.eere.energy.gov/buildings/publications/pdfs/building_america/ba_bp_devoted_cold.pdf

- U.S. Department of Energy. 2010g. *Case Study: Nelson Construction*.
http://apps1.eere.energy.gov/buildings/publications/pdfs/building_america/ba_bp_nelson_cold.pdf
- U.S. Department of Energy. 2010h. *ReVISION House, Las Vegas, NV*.
http://apps1.eere.energy.gov/buildings/publications/pdfs/building_america/ns/c14_revision_house.pdf
- U.S. Department of Energy. 2011a. *Case Study: SMUD's Energy Efficient Remodel Demonstration Project, 32nd Ave, Sacramento*. (Not online yet.)
- U.S. Department of Energy. 2011b. *Home Energy Saver: Hall of Shame*. Prepared for DOE by the Lawrence Berkeley National Laboratory. www.hes.lbl.gov/consumer/pros-shame
- U.S. Department of Energy. 2011c. *Building America Best Practices Series Volume 13: Preserving Historic Homes*, PNNL-20185. Prepared for DOE by the Pacific Northwest National Laboratory.
http://apps1.eere.energy.gov/buildings/publications/pdfs/building_america/historic_homes_guide.pdf
- U.S. Department of Energy. 2011. *Wall Insulation Strategy: Minimizing Thermal Bridging*. Prepared by Consortium for Advanced Residential Buildings for DOE. Accessed 9-12-11.
www.carb-swa.com/articles/guidelines/Gut%20Rehab%20Thermal%20Break%20Guide.pdf
- U.S. Department of Energy. 2011. *Wall Insulation Strategy: Minimizing Thermal Bridging*. Prepared by Consortium for Advanced Residential Buildings for DOE. Accessed 9-13-11.
www.carb-swa.com/articles/guidelines/Gut%20Rehab%20Thermal%20Break%20Guide.pdf
- U.S. Department of Energy. 2011. *Wall Insulation Strategy: Minimizing Thermal Bridging*. Prepared for DOE by the Consortium for Advanced Residential Buildings. Accessed 9-15-11.
www.carb-swa.com/articles/guidelines/Gut%20Rehab%20Thermal%20Break%20Guide.pdf
- U.S. Environmental Protection Agency. 2003. *Asbestos: Current Best Practices for Vermiculite Attic Insulation - May 2003*.
www.epa.gov/asbestos/pubs/insulation.html#What Volume 12.

Appendix A

How Insulation Works: Understanding Heat Flow and Air Pressure

Insulation reduces the movement of heat between your home and the outside, keeping the interior cool in summer and warm in winter. Understanding insulation means understanding heat flow and air pressure.

Heat Flow

Heat tends to flow from a warm space to a cool space. Your walls, ceilings and floors form a “thermal envelope” around the air in your home. In the winter, heat from inside the thermal envelope moves to any area that’s cooler—the outdoors and the unheated parts of your house. In the summer, heat flows into the cooler interior of your home. The larger the temperature difference between the inside and the outside, the faster the heat will move.

Heat moves in and out of your house through a number of areas: construction joints and seams, penetrations in your walls for pipes and wires, cracks around doors and windows, and your attic access opening. Heat also moves directly through walls, floors, ceilings, and windows. All materials, including wood, metal, and glass, allow some measure of heat to pass through them. Insulation is made of materials that have a high resistance to heat flow.

Heat is transferred in three ways: conduction, convection, and radiation (Figure A.1).

CONDUCTION. Conduction is the movement of heat through a solid material. For example, the heat from a stove moves through a saucepan to its contents. In a building, heat flows from the warmer side of a wall to its cooler side. A material’s resistance to conduction is called its R-value. The more resistant a material is to allowing heat to flow through it, the higher its R-value.

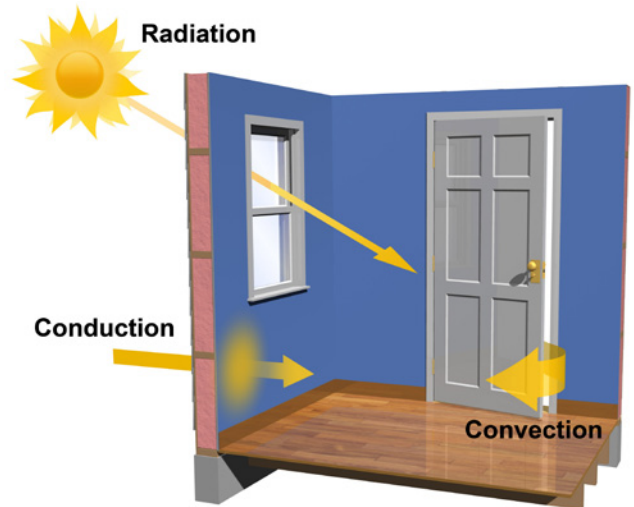
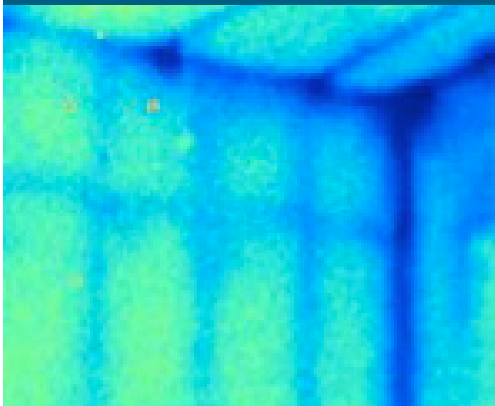


Figure A.1. Heat is transferred through conduction, convection, and radiation (Source: PNNL).



Heat flow. An infrared camera shows thermal bridging—heat moving through the wood framing into the home by conduction (Photo Source: DOE).

Most of a home's heat is typically lost through conduction. Lumber, which provides the frame for your home's thermal envelope, is not very good at resisting heat flow. It conducts some heat and has an R-value of about R-1. The best way to slow down conduction is to insulate.

CONVECTION. Convection is the movement of heat through air (as well as through liquids and other gases). In simple terms, warm air becomes buoyant and rises to the top of a structure. Cold air sinks.

The most effective strategy for stemming convective heat loss is to reduce the amount of air that flows through cracks and holes in the walls, ceilings, and floors. Filling the wall cavities with insulation and sealing the air leaks will eliminate cold spots in walls. Insulating and air-sealing floors and ceilings will also reduce the amount of warm air being lost to the attic and the amount of cold air coming into the thermal envelope from the crawlspace or basement.

RADIANT ENERGY. On a sunny day, you'll feel warmer sitting in the sun than in the shade, although there is little difference in air temperature. The warmth you're feeling is radiation, which flows through space in the form of waves. These waves have two types: solar radiation, which is radiant energy from the sun, and infrared radiation, which is radiant energy reflected back from the earth into space. Radiation heats anything solid that absorbs its energy.

Radiant heat has an impact on indoor comfort. Radiant heat from a sun-heated window can make you feel warmer than the air temperature suggests. Radiant heat also affects your home's energy efficiency. During the day, sunshine warms your house. At night, your house can radiate heat to a clear night sky. The resulting cooling can lead to condensation in your attic or the underside of your roof if the temperature inside your attic drops below the dew point.

Roof overhangs, window awnings, and tree shading help reduce radiation from the sun to your home. In hot-dry and hot-humid climates, you can reduce heat gain by installing a radiant barrier in an unsealed attic (see Appendix C). In cold climates, however, radiant barriers are seldom cost-effective. Homeowners in hot climates can also benefit from re-roofing with light-colored material. Light-colored roofs keep a building cooler by reflecting the sun's heat away from the building. In cold climates, however, light-colored roofs are not recommended; they can increase energy use by reducing the sun's ability to heat the home in winter.

Air Pressure

Another factor in energy efficiency is air pressure.

You may recall that air moves naturally from areas with higher pressure to areas with lower pressure. For example, air in an inflated balloon is under pressure. Poke a hole in the balloon and the air will flow out quickly. The larger the pressure difference between the air in the balloon and the outside air, the faster the air will move. Positive pressure refers to an enclosure with higher air pressure than the area around it, like an inflated balloon. Negative pressure refers to an enclosure with lower air pressure than the area around it. A vacuum cleaner works because air moves from the higher-pressure room into the lower-pressure canister.

In your home, differences in air pressure affect the flow of heat and moisture. For example, your bathroom fan sucks out air, putting the room under negative pressure. Air from other parts of the house rushes into the bathroom.

Factors that change air pressure in homes are temperature, height, ventilation fans, furnace blowers, chimneys, and the wind.

TEMPERATURE. During the winter, warm indoor air rises, creating positive pressure at the top of your house. This positively pressured, warmer air naturally flows out of your living space to where the air is cooler and has lower pressure. It exits to the attic through air leaks, gaps in your existing insulation, penetrations in the walls and ceiling, and the attic access door.

This movement of warm air to the top of the house creates lower air pressure at the bottom of the house. This negative pressure pulls cold outside air into the lower part of the house through air leaks, insulation gaps, penetrations in the walls and floor, and crawlspace vents.

This air movement from bottom to top is called the **stack effect**. The greater the difference in temperature between the inside and the outside, the greater the stack effect. Insulating and sealing air leaks in the attic can dramatically reduce the stack effect and the resulting heat loss.

BUILDING HEIGHT. The force of the stack effect also depends on the height of a building. The taller your house, the more pressure difference there will be between the bottom and the top.

VENTILATION FANS AND FURNACE BLOWERS. A fan or furnace blower that forces air into the home creates positive pressure, which will push air out of the top of the house. On the other hand, negative pressure is created by the exhaust fans for your kitchen, bathroom, and clothes dryer. “Make-up air” will be pulled in through air leaks, insulation gaps, penetrations, and leaky ducts.

CHIMNEYS. The stack effect naturally moves air up a chimney, reducing air pressure in the lower part of the home. However, if the negative pressure inside a house becomes too great, it can pull air down the chimney and into the house—a dangerous situation called backdrafting.

WIND. Wind creates positive pressure on the side of your house facing the wind, and negative pressure on the side away from the wind. These pressures push and pull air through leaks and penetrations in your home’s thermal envelope.

What Makes Insulation Effective

Insulation works by slowing the movement of heat, whether by conduction, convection, radiation, or differences in air pressure. The more heat flow resistance your insulation provides, the lower your heating and cooling costs will be. The heat resistance of insulation is called its R-value. The higher a material’s R-value, the better it is at stopping heat transfer.

Different kinds of insulation address the different ways heat travels. In general, insulation and its essential accompaniment, air sealing, work by:

- Forming an air barrier – reducing the movement of interior or exterior air moving through your home’s thermal envelope.
- Hindering heat transfer – trapping air in millions of tiny pockets.
- Minimizing thermal bridges – reducing the conduction of heat through concrete, wood, and metal.
- Retarding vapor – reducing the movement of moisture through the building envelope.

Appendix B

Air Leakage, Moisture, and Ventilation: Why You Need a “Whole-House” Approach

Discomfort, moisture, and big energy bills are symptoms that a home needs thermal improvements. The following symptoms occur because of the links between temperature, air quality, and moisture. Simply adding insulation will not solve these problems; it may even create new ones. Making the entire home comfortable, safe, durable and energy-efficient requires a whole-house approach to control the flow of heat, air, and moisture.

Winter Symptoms

- drafts
- cold floors
- uneven temperatures from room to room or floor to floor
- walls that are cold to the touch
- condensation on windows, walls, or ceiling surfaces
- visible mold or mildew growth on any surface
- water-damaged finishes or water stains
- cracked or missing caulking
- ice dams or icicles
- high heating bills.

Summer Symptoms

- warm or muggy inside air
- visible mold or mildew growth on any surface
- condensation on windows, walls, or ceiling surface
- uneven temperatures from room to room or floor to floor
- mold growth in the basement
- high energy bills for air conditioning.



Building science. When performing energy upgrades on an existing house, it's important to take a whole-house approach that addresses the interactions of heat flow, air flow, and moisture management (Photo Source: PNNL).



Air leaks. There are numerous spots where air can leak into or out of a house, wasting energy and risking problems with moisture and air quality.

B.1. Air Leakage

Air leaks carry both moisture and heat, usually in the direction you don't want. Air movement accounts for more than 98% of all water vapor movement in building cavities (DOE 2011). Air naturally moves from a high pressure area to a lower one—generally through any available hole or crack in the thermal envelope (see Appendix A).

Air leakage can create significant problems. If the moisture in air condenses on organic surfaces such as wood or paper-faced drywall, it can lead to mold and rot inside the walls and in other parts of the house. Air leaks allow dust, pollen, and mold spores to enter the house, contributing to health problems. In a typical home, air leakage accounts for 25% to 40% of the energy used for heating and cooling.

Air leaks are a problem within a house as well as between the house and the outside. Building scientists talk about your home's "thermal envelope"—the floors, ceilings, walls, windows, and doors that surround the space in which you live, keeping it warm in winter and cool in summer. Parts of the house may be outside the thermal envelope—an unfinished attic or basement, a crawlspace or garage. Air is leaked between your home's thermal envelope and unconditioned parts of the house.

Chimneys and the cracks around doors and windows are well-known trouble spots when it comes to air leakage. But often the leaks between the thermal envelope and other parts of the house are much greater. Air leaks through:

- ceilings
- floors above an unconditioned basement, garage, or vented crawlspace
- leaky ducts
- plumbing and electrical wiring penetrations
- gaps around electrical outlets, switch boxes, and recessed lights
- gaps behind recessed cabinets and false ceilings, such as kitchen or bathroom soffits
- gaps around attic access hatches and pull-down stairs
- duct chases
- furnace flues
- walls behind bath tubs and shower stalls
- walls between the living space and the garage
- basement rim joists—where the foundation meets the wood framing

- cantilevered floors
- attic kneewalls
- any openings or cracks where two walls meet, where the wall meets the ceiling, or near interior door frames.

Most insulation does not stop airflow. Before you add insulation, sealing a home to reduce air leakage is essential. It is inexpensive and highly effective.

Appendix C provides Performance Briefs on air sealing and insulating many of the leakage sites listed above. For additional information on air sealing, see Building America's Air Sealing Guide at http://apps1.eere.energy.gov/buildings/publications/pdfs/building_america/ba_airsealing_report.pdf

B.2. Moisture

Done right, adding insulation and air sealing can cure moisture problems.

One reason moisture problems develop is because of differences in surface temperatures. You may recall that warm air is able to carry more moisture than cool air. When air meets a cold surface, it cools. If its temperature drops below the dew point, the air deposits moisture on the cold surface. This is why inefficient windows or poorly insulated walls may have condensation in wintertime. Moisture buildup in walls can lead to mold and mildew, wood rot, and subsequent structural and health problems.

Moisture can also be deposited in walls during the summer. In an air-conditioned home, warm air comes in through leaks in the thermal envelope. As that air enters a wall assembly, it hits the back of the interior wall, which has been cooled by air conditioning. If the air temperature drops below the dew point, the air will deposit moisture inside the wall cavity.

Insulation itself can cause moisture problems. When you insulate a wall, you change the temperature inside it. A surface inside the wall can be much colder in the winter than it was before you insulated. Without proper moisture control, this surface could become a place where water vapor traveling through the wall condenses and leads to trouble. The same thing can happen in the attic or in a crawlspace or basement.

However, with careful design, insulation and air sealing can prevent condensation and keep your walls, attic, and basement or crawlspace drier than they were before. A contractor certified in building science principles (see Chapter 1) can advise you on this.

Building codes in some areas require the use of vapor retarders to help control moisture. For information, see Section B.4 below.

The Whole-House Approach

Improving the thermal envelope, like any renovation, requires careful planning. The interactions of all of your home's components, including its ventilation, must be taken into account to maximize performance and avoid unintended consequences. This "whole-house" approach recognizes that changes in one component can dramatically change how other components perform.

Dew Point

The dew point is the temperature at which water vapor starts to condense. Above the dew point temperature, moisture stays in the air. At or below the dew point, moisture leaves the air and condenses on a cool surface, like the glass for your iced tea.

More Information

For more information on heat and energy recovery ventilators, see the U.S. Department of Energy's Energy Saver site: www.energysavers.gov/your_home/insulation_airsealing/index.cfm/mytopic=11900

B.3. Ventilation

When you perform air sealing, you must ensure that your home will be well ventilated. Replacing stale air with fresh air is essential for health and comfort. Poorly ventilated homes can accumulate chemicals, gases, mold, dust, and moisture. You and your family generate moisture every time you cook, shower, and do laundry. Just by breathing and perspiring, a typical family adds about 3 gallons of water per day to their indoor air (DOE 2008).

Most homes rely on random air leakage to supply fresh air and prevent the buildup of stale inside air. But, as noted above, these uncontrolled leaks cause their own problems.

To provide proper ventilation, your contractor may recommend adding ventilation fans, also known as a mechanical ventilation system. There are several options. Spot ventilation—using exhaust fans in the kitchen and bathroom, removes water vapor and pollutants from specific locations in the home, but does not supply fresh air. Supply-side ventilation delivers fresh air but brings in moisture and hot or cold air from outside. This fresh air usually comes from an intake connected to the return side of your air handler, using the central heating system's fan and ducts to distribute the air. If you don't have a central heating system, a dedicated fan can be attached to a fresh air intake to draw in outside air. Balanced ventilation systems, such as air-to-air exchangers, heat-recovery ventilators, and energy recovery ventilators, supply and exhaust equal amounts of air to the house. The outgoing air tempers the incoming air, saving heat and energy. Your contractor can help you determine which approach is most appropriate for your specific climate, house design, and budget.

Table B.1. Pros and Cons of Various Mechanical Ventilation Systems

(Adapted from Rudd, A. 2011. "Local Exhaust and Whole House Ventilation Strategies," prepared by BSC for DOE Building America)

Ventilation Type	Pros	Cons
Exhaust Only (air is exhausted from the house with a fan)	<ul style="list-style-type: none"> Inexpensive Easy to install Simple method for spot ventilation 	<ul style="list-style-type: none"> Removes heated or cooled air Makeup air is from random sources May create negative pressure in house, causing backdrafting
Supply Only (air is supplied into the house with a fan)	<ul style="list-style-type: none"> Does not interfere with combustion appliances Creates positive pressure in house, inhibiting the entry of pollutants Delivers fresh air to important locations 	<ul style="list-style-type: none"> Brings in moisture and hot or cold air from outside Does not remove indoor air pollutants at their source Air circulation can feel drafty Furnace fan runs more often unless fan has an ECM (variable-speed motor)
Balanced Air Exchange System (heat and energy recovery ventilators)	<ul style="list-style-type: none"> No combustion impact Can be regulated to optimize performance Provides equal supply and exhaust air Recovers up to 80% of the energy in air exchanged, significantly reducing energy cost 	<ul style="list-style-type: none"> With installation, may cost between \$700 and \$2,000 More complicated design considerations Can overventilate if building is not tight

B.4 Vapor Retarders

Vapor retarders are often installed to impede the movement of water vapor through walls and other building materials. A number of materials are used as vapor retarders; they vary in performance. Building scientists use a unit of measure called “perms” to denote a material’s permeability to vapor. The higher the perm number, the more easily vapor can pass through the material.

The recommended placement of vapor retarders depends on climate. Moist air generally moves from warmer places to colder ones. Where homes are heated much of the year, vapor retarders are typically placed on the interior side of insulation to keep out moisture carried by warm indoor air. Where homes are air-conditioned much of the year, vapor retarders are typically placed on the exterior side of insulation to keep out moisture carried by warm outdoor air. A vapor retarder should not be placed on both sides of the insulation. Any moisture that reaches the insulation must be able to diffuse either to the interior or the exterior.

Presently, research into the usefulness of vapor retarders is inconclusive. Evidence shows they sometimes trap moisture inside walls by hindering evaporation (Lstiburek 2004). The following precautions may help:

SHEET POLYETHYLENE. Avoid using sheet polyethylene and other Class I vapor retarders, except in the very cold and subarctic climates. Class I vapor retarders are materials with extremely low permeability, and are commonly called vapor barriers. Building America scientists warn that the use of Class I vapor retarders can cause serious moisture problems in humid climates. Class I vapor retarders include foil and sheet metal as well as plastics such as polyethylene, and have a perm rating of less than 0.1. The 2009 IRC does not require a Class I vapor retarder in any climate zone. In the very cold and subarctic climates, however, they can be of value (Lstiburek 2006).

VAPOR RETARDERS IN COLD CLIMATES. Local building codes may require a vapor retarder on the interior, warm-in-winter side of insulation. You should not consider using a Class I vapor retarder unless the house has a vapor-permeable air barrier such as housewrap on the exterior of the sheathing. Otherwise, moisture in the wall will not be able to evaporate to the outdoors. If a home is air-conditioned in summer, Building America scientists do NOT recommend installing a Class I vapor retarder on the interior side of a wall assembly. Moisture coming from outside can condense on the wall’s cool interior surface, leading to mold and wood rot. Where a vapor retarder is desired or required in conjunction with cavity insulation, a good choice is paper-faced batt insulation or gypsum wallboard with latex paint (Lstiburek 2006).



Vapor retarders and mold. Vapor barriers like this polyethylene sheet can trap moisture in walls. The damp fiber insulation in this wall developed mold and odors (Source: BSC).

Class I vapor retarders, a.k.a. vapor barriers

Frequently a distinction is made between vapor barriers and vapor retarders. Vapor barriers are formally called Class I vapor retarders. They have extremely low permeability and include sheet polyethylene and other plastics, foil, and metal sheathing.

Building America scientists do NOT recommend using polyethylene or other Class I vapor retarders in humid climates because they can trap moisture inside walls and other building assemblies. A Class II or III vapor retarder should be used whenever possible; they provide protection against moisture but still permit wet materials to dry. Class II includes kraft facing on fiberglass batts, and Class III includes latex paints.

References

Lstiburek, Joseph. 2004. *Insulations, Sheathings and Vapor Retarders*. RR-0412, Building Science Corporation. www.buildingscience.com/documents/reports/rr-0412-insulations-sheathings-and-vapor-retarders

Lstiburek, Joseph. 2006. *Understanding Vapor Barriers*, BSD-106, Building Science Corporation. www.buildingscience.com/documents/digests/bsd-106-understanding-vapor-barriers

U.S. Department of Energy. 2008. *Insulation Fact Sheet*. DOE/CE-0180. www.ornl.gov/sci/roofs+walls/insulation/ins_01.html

U.S. Department of Energy. 2011. *Energy Savers: How Moisture Moves through a Home*. www.energysavers.gov/your_home/insulation_airsealing/index.cfm/mytopic=11760

VAPOR RETARDERS IN HOT CLIMATES. Local building codes may require a vapor retarder on the exterior side of insulation. If you choose a Class 1 vapor retarder such as foil-faced sheathing, your contractor must make sure moisture can evaporate to the indoors. When using any kind of vapor retarder on the exterior of the insulation, avoid filling the walls with faced insulation batts; the facings can trap moisture in the walls. Vinyl wallpaper or other “nonbreathable” wall coverings will also trap moisture. Remove them.

VAPOR RETARDERS IN MIXED CLIMATES. The location of a vapor barrier or retarder is problematic in mixed climates, which are cold in winter and hot in summer. Since moist air generally moves from warmer places to colder ones, moisture needs to diffuse to the exterior in winter and the interior in summer. A vapor retarder will prevent one or the other, depending on where it is located. Building America scientists suggest that it may be better to have a vapor-open assembly in mixed climates (Lstiburek 2004). Local building codes, however, may require a vapor retarder.

Vapor Retarder Definitions

The 2009 IRC R601.3.2 gives the following definitions and examples for vapor retarder classes:

Class	Definition	Examples
I	0.1 perm or less	Sheet polyethylene, sheet metal, non-perforated aluminum foil
II	Greater than 0.1 perm to less than 1.0 perm	Kraft-faced fiberglass batts or low-perm paint
III	Greater than 1.0 perm to less than 10 perm	Latex or enamel paint

Perm Ratings of Common Sheathing Materials

Material	Permeability
Plywood sheathing	More than 1.0 perm
OSB	More than 1.0 perm
Exterior gypsum	More than 1.0 perm
Fiberboard sheathing	More than 1.0 perm
Extruded polystyrene foam sheathing 1 inch	1.0 perm or less
Film-faced extruded polystyrene 0.5 inch thick with perforated facing	More than 1.0 perm
Nonperforated foil-faced rigid insulation	Less than 0.1 perm
Polypropylene-faced rigid insulation	Less than 0.1 perm
Three-coat, hard-coat stucco over 2 layers of Type D asphalt-saturated Kraft paper and OSB	Less than 1.0 perm

Source: Lstiburek 2006.

Appendix C

Building America Energy Performance Briefs for Improving Existing Homes

The Performance Briefs provide step-by-step instructions that your contractor can follow when implementing the following upgrades:

1. Air Sealing a Flue or Chimney Shaft
2. Improving Recessed Lighting
3. Air Sealing Duct Boots and Duct Chases
4. Preventing Ice Dams
5. Insulating Attic Kneewalls
6. Installing a Radiant Barrier in the Attic
7. Insulating and Air Sealing Cantilevered Floors –
8. Air Sealing a Porch Wall
9. Insulating and Air Sealing Tubs
10. Air Sealing and Insulating Fireplace Enclosures
11. Insulating Pipes
12. Insulating Hot Water Heaters
13. Keeping Wind-blown Rain Out of Soffits
14. Installing Sidewall and Kick-out Diverter Flashing
On Homes with Rigid Foam Insulation Sheathing
15. Installing Sidewall and Kick-out Diverter Flashing
On Homes with Housewrap over OSB or Plywood Sheathing

Improving Existing Homes:

Air Sealing a Flue or Chimney Shaft

**BUILDING AMERICA
ENERGY PERFORMANCE BRIEF**



You can make a sheet metal or gypsum board dam to keep insulation from touching hot metal or masonry chimneys and flues (Source: EPA 2008a).

When to Do This

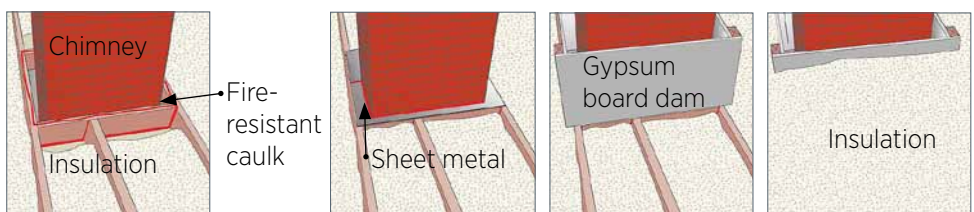
When you want to add insulation in the attic.

Durability & Health

Use the right air sealing products and techniques to keep flammable materials from touching hot flues. If combustion appliances are present in the home, always conduct combustion safety testing before and after any air sealing measure.

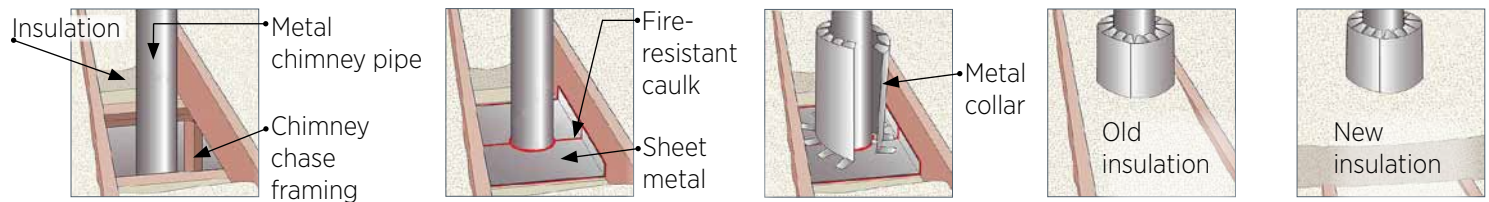
There are often gaps around chimneys and furnace and water heater flues that allow conditioned air to flow up into the attic. Insulation should not come in contact with a hot chimney or flue. The steps below show you how to safely block the air gaps around masonry chimneys and flue pipes and then construct an insulation dam to allow insulation to be placed around the chimney or flue pipe while maintaining a 3-inch clearance for fire safety. With metal chimneys and vent pipes, you can use sheet metal to form an insulation dam and air block, installed level with the bottom of the framing (see Option 1 next page) or on top of the framing (see Option 2).

How to Air Seal a Masonry Chimney Chase



- 1 Remove any insulation around the chimney. Caulk seams of framing and add a wide bead of fire-resistant caulk to the top of the framing around the chimney.
- 2 Cut the sheet metal to fit around the chimney. Fasten to the framing with nails or screws. Seal to the chimney with fire-resistant caulk.
- 3 Build a gypsum or sheet metal dam to keep insulation at least 3 inches from the chimney on all sides. Make dam 4 inches higher than the finished insulation level.
- 4 Replace any old insulation and add additional insulation to desired height (Source: Lstiburek 2010).

How to Air Seal a Metal Chimney or Flue Vent Pipe – Option 1 – Air Seal at Bottom of Framing



- 1 Pull insulation away from metal chimney pipe.
- 2 Cut two pieces of sheet metal to cover the chase opening. Allow 1 inch of overlap. Fasten the sheet metal to the framing and seal all edges and seams with fire-rated caulk.
- 3 Use sheet metal to make a shield that will wrap around the pipe with a 3-inch clearance. Fold tabs at top and every other tab at bottom in to maintain a 3-inch clearance. With tabs folded, shield should be 4 inches taller than finished insulation level.
- 4 Replace insulation.
- 5 Add more insulation to desired height. Insulation should cover rafters (Source: Lstiburek 2010).

References

DOE. 2010. *Building America Best Practices Series, Volume 10: Retrofit Techniques and Technologies: Air Sealing*, PNNL-19284, U.S. Department of Energy. www1.eere.energy.gov/buildings/building_america/publications.htm.

EPA. 2008a. *A Do-It-Yourself Guide to Sealing and Insulating with ENERGY STAR*. U.S. Environmental Protection Agency, www.energystar.gov/index.cfm?c=diy.diy_index

EPA. 2008b. "Indoor Air Quality and Attics." U.S. Environmental Protection Agency, www.epa.gov/iaq/homes/hip-attic.html

Lstiburek, Joseph. 2010. *Guide to Attic Air Sealing*. Prepared for U.S. Department of Energy by Building Science Corporation. <http://www.buildingscience.com/documents/guides-and-manuals/gm-attic-air-sealing-guide>.

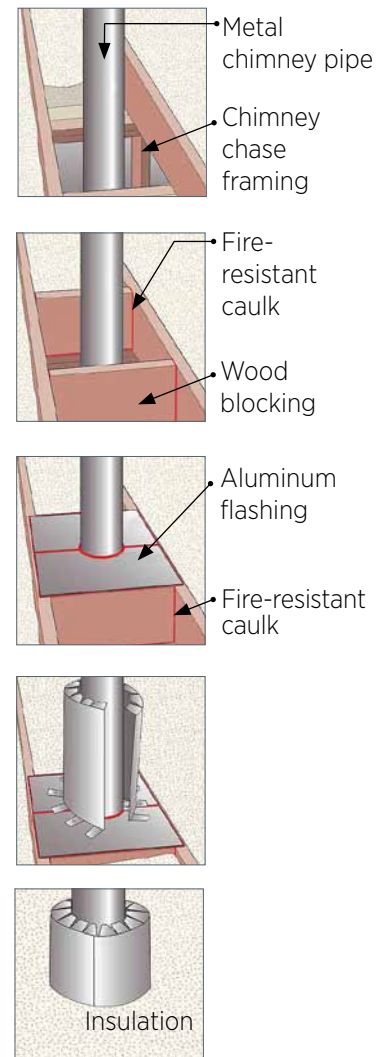
2009 IECC/2009 IRC

Code Requirement for New Construction and Additions

Shafts, penetrations – Duct shafts, utility penetrations, knee walls and flue shafts opening to exterior or unconditioned space are sealed.

Option 2 – Air Seal at Top of Framing

- 1 Pull insulation away from metal chimney pipe.
- 2 Cut two pieces of framing lumber equal in height to the ceiling joists. Fasten cross pieces to joists keeping at least 3 inches of clearance to the pipe. Caulk wood blocking to framing.
- 3 Cut two pieces of sheet metal or aluminum flashing to fit around the chimney pipe with 1 inch of overlap. Fasten the sheet metal to the framing and seal all edges and seams with fire-rated caulk.
- 4 Use sheet metal to make a shield that will wrap around the pipe with a 3-inch clearance. Fold in tabs at top and every other tab at bottom to maintain a 3-inch clearance. With tabs folded, shield should be 4 inches taller than finished insulation level.
- 5 Replace insulation and cover with additional insulation to desired height. Insulation should cover rafters (Source: Lstiburek 2010).



**BUILDING AMERICA
ENERGY PERFORMANCE BRIEF****Improving Existing Homes:
Improving Recessed
Lighting****When to Do This**

When remodeling includes replacing ceiling fixtures or painting ceilings, or when adding insulation to the attic. Recommend that homeowner replace incandescent bulbs with compact fluorescents any time.

Durability & Health

Non-airtight recessed can fixtures can draw heated air into the attic in winter, carrying moisture that can condense in a cool attic. They can also allow hot attic air into the home in summer, pulling dust and insulation particles into the home.

If combustion appliances are present in the home, always conduct combustion safety testing before and after any air sealing measure.

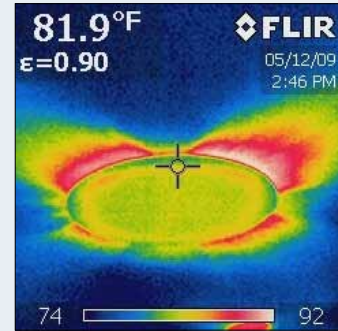
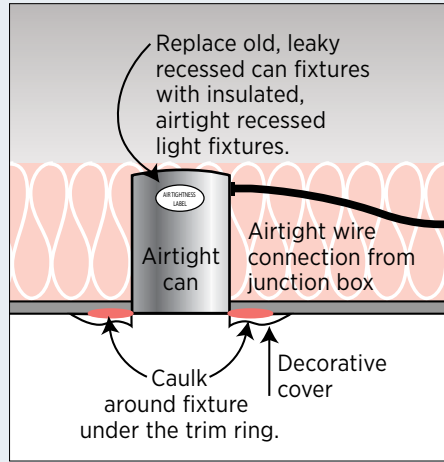
Do not let insulation come in contact with non-IC rated fixtures, due to the risk of fire.

Recessed downlights (also called can lights or high-hats) are the most popular lighting fixture installed in U.S. homes today. Unfortunately they can be a significant source of energy loss. Older model recessed can fixtures are energy intensive in three ways. If they are not approved for insulation contact, insulation has to be kept at least 3 inches from the fixture, leaving a square foot or more of uninsulated ceiling space. When the lights are turned on, the tube-shaped light fixtures heat up, and work like a chimney to pull conditioned air out of the living space into the attic, which is a waste of energy and can cause moisture problems in the attic. Many existing recessed can lights have incandescent bulbs that use 3 to 5 times the electricity of fluorescents and add to air-conditioning loads.

The best method for dealing with an old, non-airtight recessed can light is to replace the whole fixture with an insulation contact-rated, airtight (ICAT) fixture. Caulk around the fixture under the trim ring to ensure air tightness and install an ENERGY STAR-rated compact fluorescent or LED bulb that is designed for recessed can lights. Insulation can safely be laid on top of these ICAT-rated fixtures. Insulation-contact rated lights are indicated by an "IC" at the end of the model number. Another option might be to remove the can fixture, patch the ceiling, and install a surface-mounted fixture.

If the homeowner does not want to replace their non-ICAT rated recessed can lights, you can make the lights airtight by covering them from the attic side with a box made of rigid foil-faced foam or drywall. The box should be large enough to allow 3 inches of clearance on all sides of the fixture. It should be sealed in place to the ceiling drywall with spray foam, and covered with attic insulation.

Studies Show Old, recessed can lights are like a hole in the ceiling, only worse. Leaky recessed cans with incandescent bulbs can pull 3 to 5 times as much air as a hole in the ceiling the same size, thanks to the “stack effect.” The heat inside the can pulls air from the house up through the holes in the can into the attic (Source: McCullough and Gordon 2002).



This infrared camera image shows summertime attic heat leaking into the home around a leaky recessed can light.

2009 IECC/2009 IRC

Code Requirement for New Construction and Additions

Recessed lighting – Recessed light fixtures are airtight, IC rated, and sealed to drywall. Exception: fixtures in conditioned space.

References

McCullough, Jeff J. and Kelly L. Gordon 2002. “High Hats, Swiss Cheese, and Fluorescent Lighting” *Proceedings of the 2002 ACEEE Summer Study*, prepared by Pacific Northwest National Laboratory. www.aceee.org/conf/bldindex.htm

EPA. 2007. “A Do-it-Yourself Guide to Sealing and Insulating with ENERGY STAR[®] U.S. Environmental Protection Agency. http://www.energystar.gov/ia/partners/publications/pubdocs/DIY_Guide_May_2008.pdf

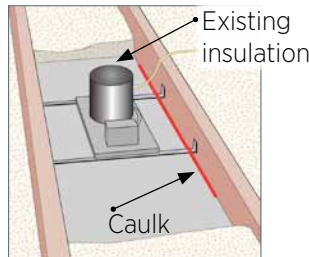
Lstiburek, Joseph. 2010. *Guide to Attic Air Sealing*. Prepared for U.S. Department of Energy by Building Science Corporation. <http://www.buildingscience.com/documents/guides-and-manuals/gm-attic-air-sealing-guide>.

For More Information

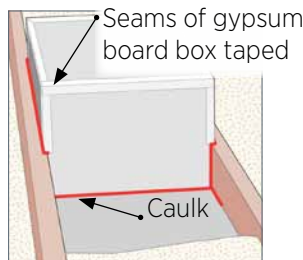
www.buildingamerica.gov
 EERE Information Center
 1-877-EERE-INF (1-877-337-3463)
eere.energy.gov/informationcenter

U.S. DEPARTMENT OF **ENERGY** | Energy Efficiency & Renewable Energy

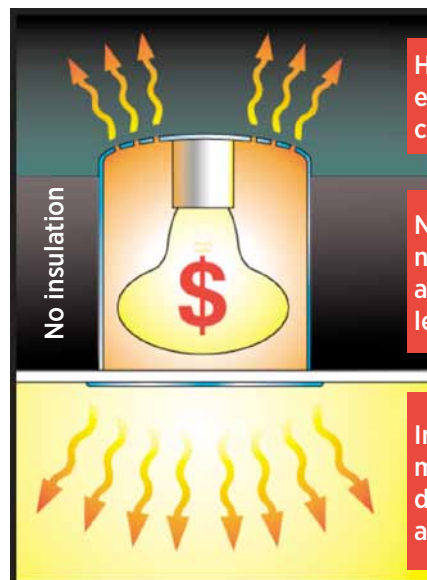
How to Insulate and Air Seal Non-insulation Contact-rated, Non-airtight Recessed Can Lights.



- 1 Pull back any insulation around the fixture.
- 2 Caulk where the ceiling gypsum board meets the rafter on each side of the fixture.
- 3 Cut gypsum board or foil-faced rigid foam insulation to form a box. Seal box seams with metal tape or mastic.



- 4 Seal the box to the ceiling dry wall and rafters with caulk or spray foam.
- 5 Replace insulation and add insulation to cover the sides of the box (Source: Adapted from Lstiburek 2010).



Holes in the top of the recessed can encourage the stack effect, pulling conditioned air up into the attic.

Non-insulation contact-rated cans mean no insulation can touch the can, which allows heat transfer around the can. Air leaks around the rim add to heat loss.

Incandescent lamps use 3 to 5 times more energy than a compact fluorescent, don't last as long, and generate heat that adds to air-conditioning bills.

Improving Existing Homes:

Air Sealing Duct Boots and Duct Chases

**BUILDING AMERICA
ENERGY PERFORMANCE BRIEF**

When to Do This

When adding attic insulation, sealing ducts, or replacing HVAC or ducts.

Durability & Health

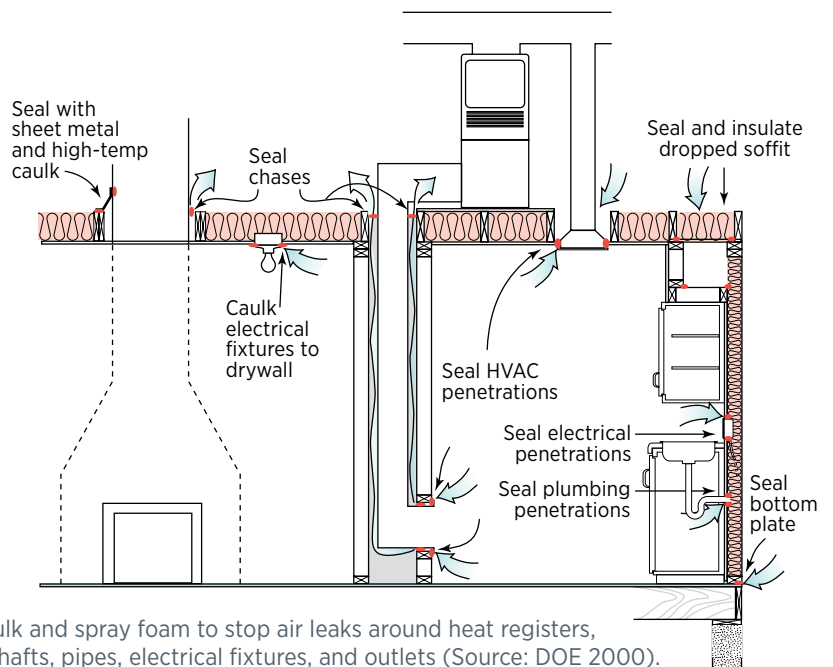
HVAC, plumbing, and wiring chases can bring conditioned air into attics, causing energy loss and leading to condensation and mold problems. If combustion appliances are present in the home, always conduct combustion safety testing before and after any air sealing measure.

2009 IECC/2009 IRC

Code Requirement for New Construction and Additions

Shafts, penetrations – Duct shafts, utility penetrations, knee walls and flue shafts opening to exterior or unconditioned space are sealed.

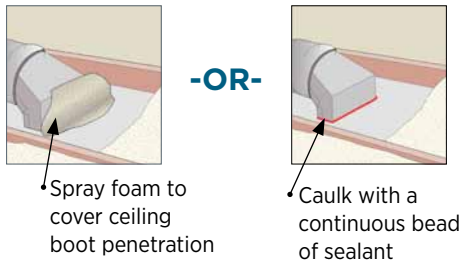
Any place where holes are made in the ceiling can become a venue for heated and cooled air to escape into the attic (as shown in the figure below). Air sealing around duct boots, duct chases, and ducts in shafts and building cavities is especially important because of the potentially large air leaks that can be present. You should inspect these areas and close the gaps with caulk, spray foam, and blocking material (pieces of rigid foam, plywood, or oriented strand board cut to fit and sealed in place with spray foam). Furnace flues may require high-temperature-rated sealing materials. Duct boots are subject to high air flow and the joints should be checked for air tightness. They can be sealed with spray foam or caulk. All duct joints and seams should be sealed with mastic, or approved metal tape, or flex duct fasteners. Studies show cloth-backed duct tape fails within months; it should not be used to seal ducts.



Use caulk and spray foam to stop air leaks around heat registers, ducts shafts, pipes, electrical fixtures, and outlets (Source: DOE 2000).

How to Seal a Duct Boot to the Ceiling

- 1 Pull back insulation to expose the duct boot.
- 2 Seal all sides of the duct boot to the gypsum board with spray foam or caulk. Apply mastic to all duct seams and joints.



- 3 Replace insulation.
(Source: Adapted from Lstiburek 2010).

References

DOE. 2000. *Air Sealing Fact Sheet*, Prepared for the U.S. Department of Energy by Southface Energy Institute and Oak Ridge National Laboratory. http://apps1.eere.energy.gov/buildings/publications/pdfs/building_america/26446.pdf

EPA. 2008. *A Do-It-Yourself Guide to Sealing and Insulating with ENERGY STAR*. U.S. Environmental Protection Agency, www.energystar.gov/index.cfm?c=diy.diy_index

EPA. 2008. *Indoor Air Quality and Attics*. U.S. Environmental Protection Agency. www.epa.gov/iaq/homes/hip-attic.html

Lstiburek, Joseph. 2010. *Guide to Attic Air Sealing*. Prepared for U.S. Department of Energy by Building Science Corporation. www.buildingscience.com/documents/primers/guide-to-attic-air-sealing-with-details/?searchterm=air%20sealing

For More Information

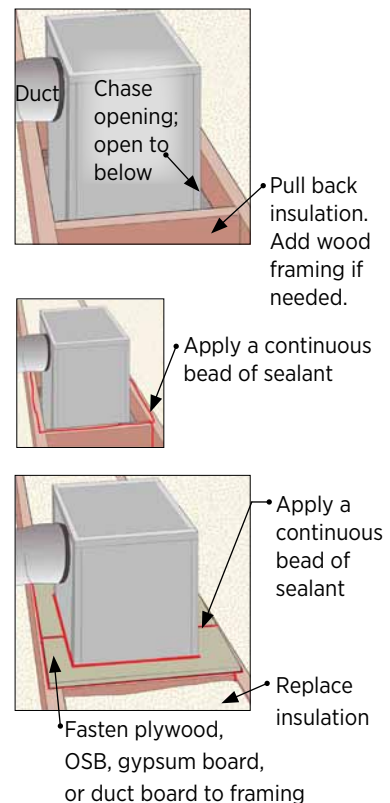
www.buildingamerica.gov
EERE Information Center
1-877-EERE-INF (1-877-337-3463)
eere.energy.gov/informationcenter

U.S. DEPARTMENT OF **ENERGY** | Energy Efficiency & Renewable Energy

How to Air Seal a Rigid Duct Chase

- 1 Pull back insulation to expose the chase and framing area. Add wood framing cross pieces in attic rafter bays if needed. Measure and cut an air blocking material like plywood, rigid foam, or drywall into strips to be fastened to framing in step 3.
- 2 Seal all framing joints around the chase with sealant. Lay a generous continuous bead of sealant along the top edge of the chase framing.
- 3 Place the blocking material on the framing leaving a 1/4-inch gap between the rigid duct and the material. Fasten in place with nails or screws. Seal the material to the duct with sealant. Also seal any joints in the blocking material. Replace the original insulation and add additional insulation.

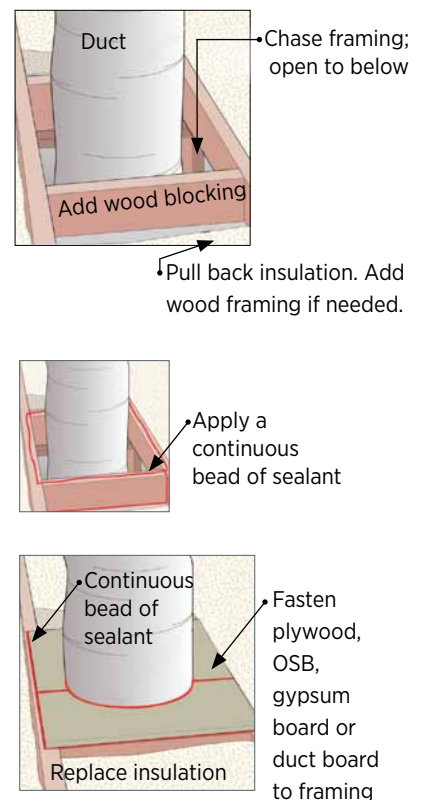
(Source: Adapted from Lstiburek 2010).



How to Air Seal a Flex Duct Chase

- 1 Pull back insulation to expose the chase and the framing area. Add wood framing pieces between rafters if needed. Measure and cut an air blocking material like plywood, rigid foam, or drywall to cover the chase opening. Cut the material into two halves and then cut half circles to encompass the flex duct.
- 2 Seal all framing joints around the chase with sealant. Lay a generous continuous bead of sealant along the top edge of the chase framing.
- 3 Place the blocking material on the framing and in contact with the duct. Fasten with nails or screws. Seal the material to the duct with sealant. Also seal the joints in the material. Replace the original insulation and add more insulation if needed.

(Source: Adapted from Lstiburek 2010).



Improving Existing Homes: Preventing Ice Dams

**BUILDING AMERICA
ENERGY PERFORMANCE BRIEF**



Icicles indicate ice dams are forming
(Photo Source: PNNL).

When to Do This

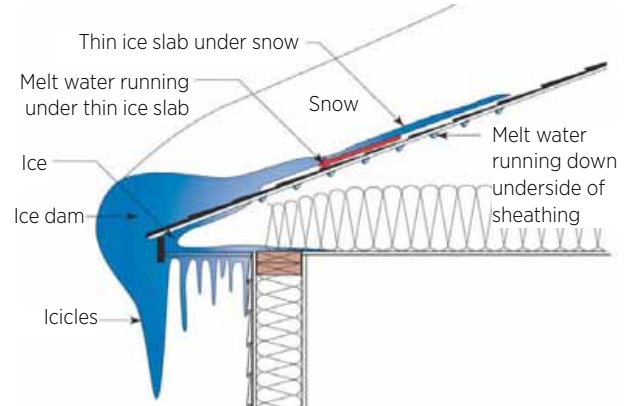
Whenever ice dams are occurring.

Durability & Health

Icicles can fall on people causing injuries. Ice dams can allow water to back up and enter the attic under roof shingles, causing structural damage and mold. Excessive water and ice accumulation can cause roofs to collapse.

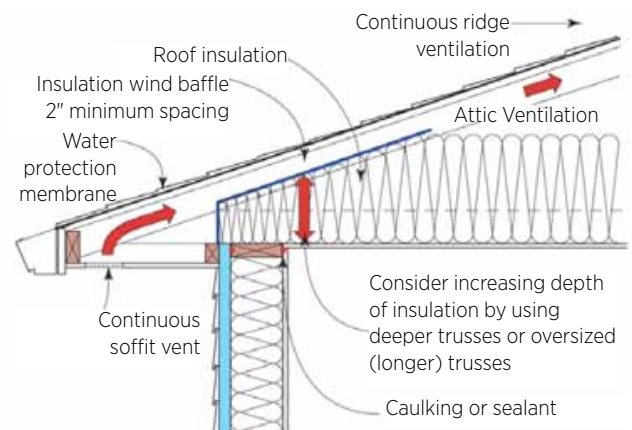


Ice dams can form when the roof deck temperature is above freezing and the air is below freezing. Melted snow eventually reaches the colder edge of the roof where it refreezes, creating an ice dam that collects more water and ice. The ice dam is often not visible under the snow except for the telltale icicles, which indicate melting is occurring somewhere on the roof (Source: Lstiburek 2011).



How to Prevent Ice Dams in Vented Attics

- 1 Construct an airtight ceiling plane. Limit the number of holes through the ceiling and air seal every one.
- 2 Insulate well, especially over the top plates, use raised heel trusses or spray foam from under baffle to ceiling deck to get full insulation coverage.



- 3 Vent the underside of the roof deck, with vent screens at every rafter bay and a 2-inch airspace under the sheathing where ground snow loads are greater than 30 lb/ft² (Source: Lstiburek 2011).

2009 and 2012 IRC R905.2.7.1

Code Requirement for New Construction and Additions

Ice Barrier – In areas where there has been a history of ice forming along the eaves causing a backup of water ... an ice barrier that consists of at least two layers of underlayment cemented together or a self-adhering polymer modified bitumen sheet shall be used in place of normal underlayment and extend from the lowest edges of all roof surfaces to a point at least 24 inches inside the exterior wall line of the building.

References

DOE. 2010. *Building America Best Practices Series, Volume 12. 40% Whole-House Energy Savings in the Cold and Very Cold Climates*, PNNL-20139, U.S. Department of Energy. www1.eere.energy.gov/buildings/building_america/publications.htm.

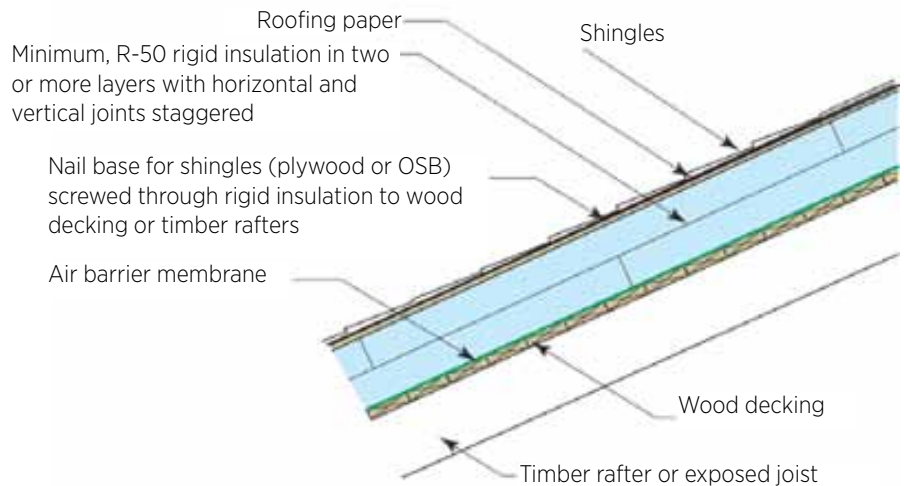
Lstiburek, Joseph. 2011. *Dam Ice Dam*, Insight 046, Feb. 2011, Building Science Corporation, www.buildingscience.com/documents/insights/bsi-046-dam-ice-dam/

For More Information

www.buildingamerica.gov
 EERE Information Center
 1-877-EERE-INF (1-877-337-3463)
eere.energy.gov/informationcenter

U.S. DEPARTMENT OF **ENERGY** | Energy Efficiency & Renewable Energy

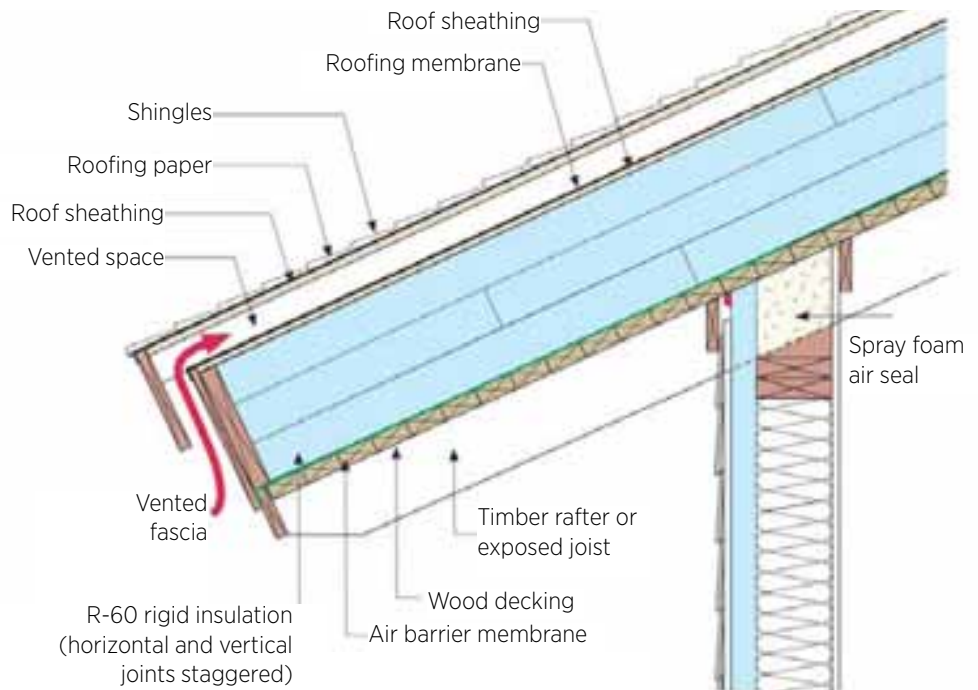
How to Prevent Ice Dams in Unvented Attics



- 1 Cover roof sheathing with a fully adhered air barrier membrane.
- 2 Install two layers (to R-50 or greater) of rigid insulation over air barrier; stagger the seams.

Note, there is no vented space under the roof cladding to compensate for the insulation value of the snow layer. This roof should be used where the ground snow load is less than 50 lb/ft². With ground snow loads greater than 50 lb/ft², provide a ventilation space under the roof cladding as shown below (Source: Lstiburek 2011).

How to Prevent Ice Dams in Unvented Attics in High-Snow-Load Areas



In regions with snow loads greater than 50 lb/ft², the snow can provide enough thermal resistance to allow the roof cladding to be above freezing even when the air temperature is below freezing (one foot of snow = R-10 to R-15). To prevent ice damming with an unvented attic in these conditions, construct a “vented over-roof” over the top of the “unvented compact roof” (Source: Lstiburek 2011).

Improving Existing Homes:

Insulating Attic Kneewalls

**BUILDING AMERICA
ENERGY PERFORMANCE BRIEF**



This attic kneewall has been thoroughly insulated.

When to Do This

- Any time you have access to existing attic kneewalls.
- When you are adding insulation to the attic.
- When you are adding an addition to your attic.

Durability & Health

Uninsulated walls provide cold surfaces for warm, humid indoor air to condense, encouraging mold growth. When warm indoor air gets into a cold attic through leaks in the home's thermal envelope, it can condense on rafters and other solid surfaces, encouraging mold growth. In a cold climate in winter conditions, heat escaping into the attic can warm the roof deck encouraging ice dam formation.



Kneewalls, the sidewalls of finished rooms in attics, are often left uninsulated, and open cavities between the floor joists beneath the kneewall are often a big source of air leakage. Kneewalls can also occur where a room with a cathedral ceiling is adjacent to a room with a standard height ceiling; the wall separating the two spaces is often uninsulated on the attic side. Your contractor can insulate these walls by filling the wall stud cavity with fiberglass batt insulation, blown fiberglass or cellulose, or spray foam (see Figure 1). The R-value of kneewall insulation should equal or exceed the code requirement for exterior walls for your climate zone.

Another option is to continue the insulation along the roof line to the attic floor with either rigid foam or cavity insulation covered with rigid foam or sheet goods (see Figure 2). This ceiling covering is air sealed to attic flooring to form an air-sealed enclosed space, which insulates the kneewall and provides insulated attic storage space.

Doors cut into kneewalls should also be insulated and airsealed by attaching rigid foam to the attic side of the door, and using a latch that pulls the door tightly to a weather-stripped frame. Closets or drawers cut into the kneewalls should also be insulated (see Figure 3).

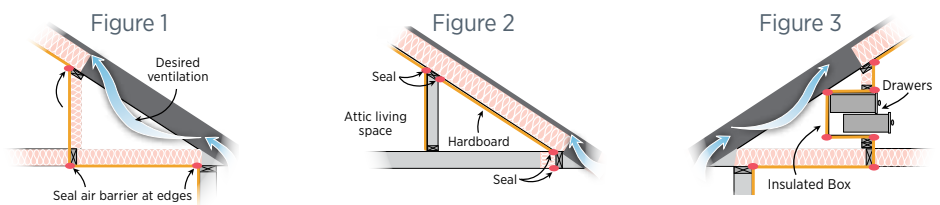


Figure 1. Insulate and air seal the kneewall (Source: DOE 2000).

Figure 2. Continue the insulation along the roof line to the roof edge. Cover with a sheet good that is caulked where it meets the wood floor sheathing, which is extended to the outside wall.

Figure 3. Build an airtight, insulated box around any drawers or closets built into attic kneewalls that extend into uninsulated attic space. Insulate along the air barrier (shown in yellow on drawing) or along the roof line with rigid foam.

References

U.S. Department of Energy. 2010. *Building America Best Practices Series, Volume 10: Retrofit Techniques and Technologies: Air Sealing*, PNNL-19284, www1.eere.energy.gov/buildings/building_america/publications.htm

Lstiburek, Joseph. 2010. *Guide to Attic Air Sealing*. Prepared for U.S. Department of Energy by Building Science Corporation. www.buildingscience.com/documents/primers/guide-to-attic-air-sealing-with-details/?searchterm=air%20sealing

U.S. Department of Energy. 2000. *Air Sealing Fact Sheet*, Prepared by Southface Energy Institute and Oak Ridge National Laboratory. <http://www.toolbase.org/Home-Building-Topics/Remodeling/air-sealing>

U.S. Environmental Protection Agency. 2008. *ENERGY STAR Qualified Homes Thermal Bypass Checklist Guide*. www.energystar.gov/ia/partners/bldrs_lenders_raters/downloads/TBC_Guide_062507.pdf

U.S. Environmental Protection Agency. 2008. *"Indoor Air Quality and Attics."* www.epa.gov/iaq/homes/hip-attic.html

2009 IECC

Code Requirements for New Construction and Additions

2009 IECC 402.2.3: Access doors from conditioned spaces to unconditioned spaces (e.g., attics and crawl spaces) shall be weather stripped and insulated to a level equivalent to the insulation on the surrounding surfaces.

2009 IECC 402.4.1: The building thermal envelope shall be durably sealed to limit infiltration.... The following shall be caulked, gasketed, weather stripped, or otherwise sealed with an air barrier material, suitable film, or solid material: 1. All joints, seams, and penetrations... 6. Knee walls... 10. Attic access openings... 12. Other sources of infiltration.

For More Information

www.buildingamerica.gov
 EERE Information Center
 1-877-EERE-INF (1-877-337-3463)
eere.energy.gov/informationcenter

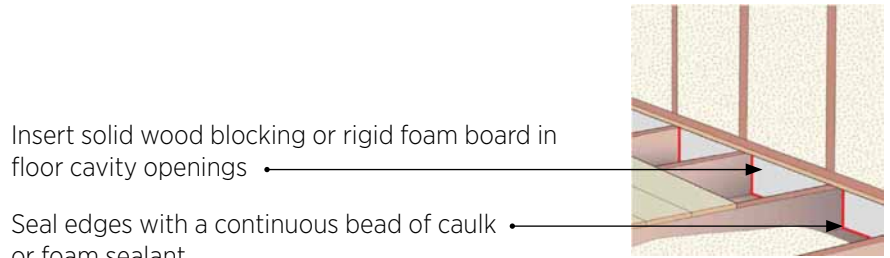
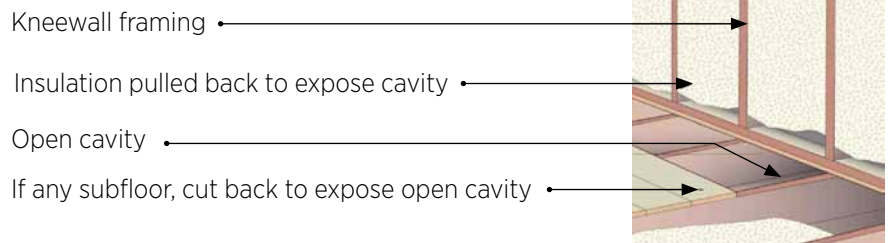


To stop air leakage from the open cavities between the floor joists under the kneewall, these cavities are stuffed with unfaced batt insulation that is rolled and covered with spray foam (see Figure 4). Or rigid foam (or another air barrier material like gypsum board or OSB) can be cut to fit each joist space and sealed in place with caulk or spray foam (see “How to” below).

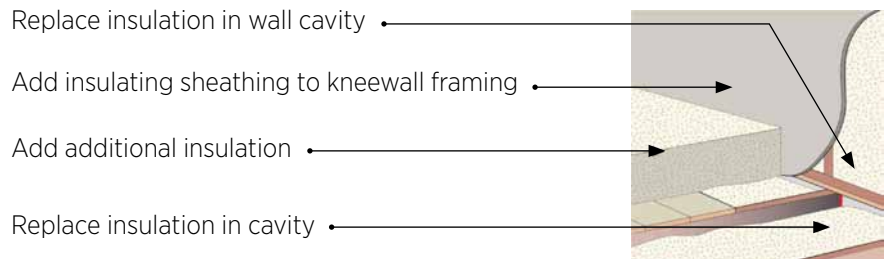
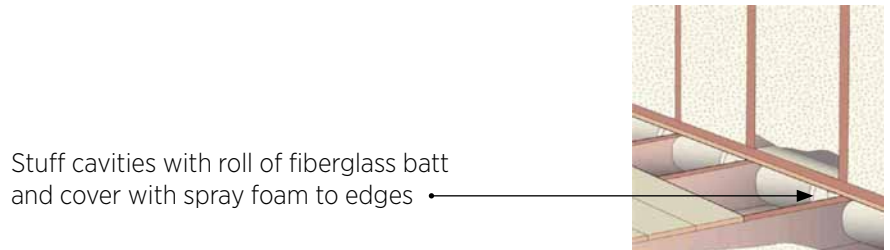


Figure 4. Air seal floor joist cavities under kneewalls by filling the cavities with rigid foam insulation, OSB, or another rigid material that is cut to fit and sealed at the edges with caulk (as shown here and below). Another option is to block the joist cavity with fiberglass batts that are rolled and stuffed in plastic bags or covered with spray foam.

How to Insulate and Air Seal Floor Joist Cavities Under Kneewalls



—OR—



(Source: Lstiburek 2010)

Improving Existing Homes:

Installing a Radiant Barrier in the Attic

**BUILDING AMERICA
ENERGY PERFORMANCE BRIEF**



In hot climates, radiant barriers can cut cooling costs 8% to 12%. In this house, a flexible radiant barrier material was draped over the rafters before installation of the roof deck. The material also can be stapled to rafters from the underside (Photo Source: Universal Forest Products).

When to Do This

When replacing the roof; any time you want to reduce energy bills and heat gain from the attic.

Climate Essentials

Hot-dry and Hot-humid climates:
reduces air conditioning costs.
Cold and Marine climates:
seldom cost-effective.

In hot climates, the sun's heat can push roof surface temperatures over 160°F. The roof's heat can radiate to the attic insulation and heat up the ceiling and living space below. This heat transfer can be reduced significantly by a radiant barrier, a foil-faced material installed under the roof that stops the transfer of heat.

If your home is in a hot-dry or hot-humid climate and has a roof that receives direct sunlight in summer, adding a radiant barrier can be cost-effective. Studies show that radiant barriers can cut cooling costs between 8% and 12% in hot climates (Melody 2005). However, radiant barriers are seldom cost-effective in marine climates, which have moderate temperatures, or in cold climates, where thick attic insulation already minimizes heat transfer. To estimate the benefit for your attic, see the U.S. Department of Energy's savings calculator at http://www.ornl.gov/sci/ees/etsd/btrc/RadiantBarrier/rb_calc.shtml

Building America scientists recommend two types of radiant barriers for existing homes. If a re-roofing project includes replacement of the roof deck, you can choose OSB sheathing with a foil underside. Your roofer should install it with the foil side facing down. If you are not replacing your roof deck, perforated radiant barrier sheeting can be attached to the truss chords or rafters in one of the two ways described below.

The radiant barrier material comes in rolls with a variety of tear-resistant backings. Products have foil on one or both sides; double-sided foil may offer little advantage over single-sided products. Be sure to buy a perforated product; it is less likely to trap vapor and cause moisture problems.

The effectiveness of a radiant barrier depends on proper installation, so it's best to use a certified installer. Your contractor should NOT install a radiant barrier in contact with attic floor insulation. Moisture will be trapped under the barrier, creating a risk of mold and wood rot.

Durability & Health

A radiant barrier increases occupant comfort by cutting the amount of heat entering a home through the attic. It increases the durability of the air conditioner by reducing the cooling load.

2009 IECC

Code Requirement for New Construction and Additions

The IECC has no code requirements for radiant barriers, but products should meet ASTM Standard C1313. Installing a radiant barrier does not change the amount of attic insulation required to meet codes.

In California, a radiant barrier can be one component of meeting the prescriptive requirements for cool roofs under Title 24, Section 152(f).

References

Melody, Ingrid. 2005. (FSEC) *Radiant Barriers: A Question and Answer Primer*. <http://www.fsec.ucf.edu/en/publications/html/FSEC-EN-15/>

Southface Energy Institute. 2004. *Home Energy Projects*. <http://www.southface.org/ez/media/homeenergyprojects.pdf>

U.S. Department of Energy. 2011. *Energy Savers: Radiant Barriers*. http://www.energysavers.gov/your_home/insulation_airsealing/index.cfm/mytopic=11680

U.S. Department of Energy. Accessed 9-8-11. *Radiant Barrier Fact Sheet: Installation Options*. Prepared by Oak Ridge National Laboratory. <http://www.ornl.gov/sci/ees/etsd/btrc/RadiantBarrier/rb4a.shtml>

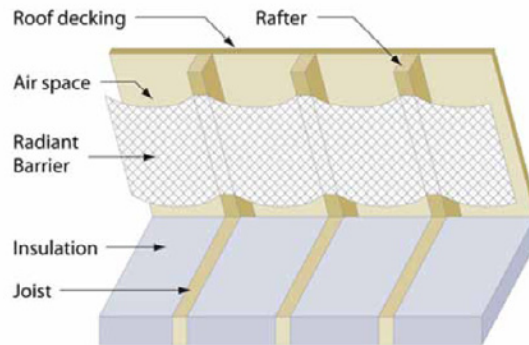
For More Information

www.buildingamerica.gov
 EERE Information Center
 1-877-EERE-INF (1-877-337-3463)
eere.energy.gov/informationcenter

U.S. DEPARTMENT OF **ENERGY** | Energy Efficiency & Renewable Energy

HOW TO INSTALL A RADIANT BARRIER: OPTION A

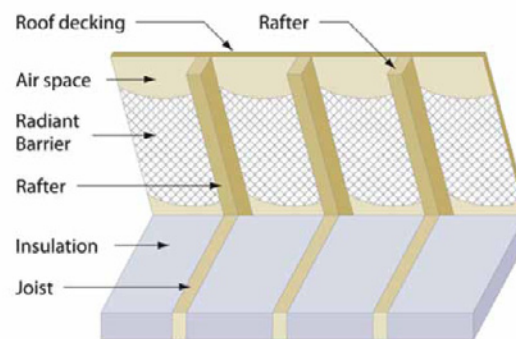
- 1 Staple the radiant barrier material, shiny side down, to the bottom of the rafters.
- 2 Follow the installation guidelines below.



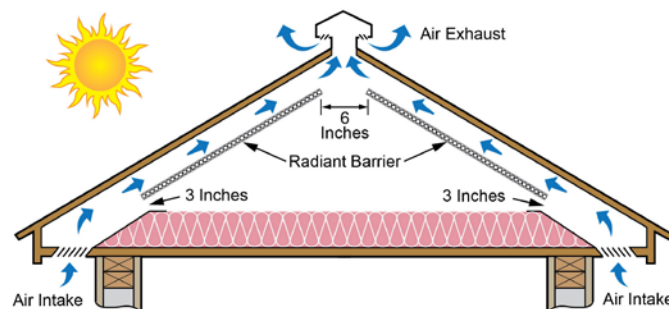
HOW TO INSTALL A RADIANT BARRIER: OPTION B

This approach can be used only when the roof deck is being replaced.

- 1 Drape the material over the rafters, shiny side down.
- 2 Let the material droop between rafters to create a 3-inch space between the material and the roof deck.
- 3 Staple the material to the top of the rafters to keep it in place.
- 4 Follow the installation guidelines below.



INSTALLATION GUIDELINES



To prevent moisture problems when installing a radiant barrier, leave adequate gaps for air flow above, below, and behind the barrier material.

- Leave a 1/2-inch airspace between the radiant barrier material and the roof deck.
- Leave a minimum gap of 6 inches (measured horizontally) between sections of material at the roof peak.
- Keep the material at least 3 inches above the insulation on the attic floor.
- Do not cover any vents.
- Cut and patch around obstructions, maintaining a 3-inch distance from any hot surface, such as a chimney, furnace, or flue pipe.
- Overlap the seams by 2 inches. The seams do not need to be sealed.
- Cover the gable ends of the attic as well as the roof deck.

**BUILDING AMERICA
ENERGY PERFORMANCE BRIEF****Improving Existing Homes:
Insulating and Air Sealing
Cantilevered Floors**

If the cantilevered floor over this porch isn't properly air sealed and insulated, the room above will feel cold and drafty in the wintertime (Photo Source: Pine Mountain Builders).

When to Do This

When heat loss at cantilevered floors is causing comfort or moisture problems. When re-siding the home.

Durability & Health

When cantilevered floors are not properly air sealed and insulated, floor and exterior wall surfaces can be cold. Warm indoor air can condense on these cold surfaces causing moisture problems.

A cantilevered floor is a floor that sticks out past the foundation or supporting wall below. It may be a first- or second-story bump-out, a bay window, or a room over an open porch.

In older homes, cantilevered floors often lack proper air sealing and insulation. Floor joist bays that extend from the house out under the cantilevered floor are often left open by the builder, allowing outside air to flow through the home and conditioned air to escape.

If you have cantilevered floors in your home, you should make sure they have been properly air sealed and insulated. If you have a basement, you may be able to check a first-floor cantilever by peering into joist bays, if they are accessible. Otherwise, you will need to remove the exterior soffit covering under the cantilevered floor to view the area between the floor joists. Sometimes cantilevered floors are insulated but not air sealed. Air barriers must be in place to stop air from blowing through the insulation, which renders the insulation ineffective.

Blocking material (rigid foam, OSB, plywood, or drywall) should be installed across any open floor joist bays to form an air barrier between the cantilever and the rest of the house. Plywood subflooring above the cantilever should be caulked at the edges and seams. The cantilever floor cavity must be filled with insulation that completely touches the underside of the floor. Insulating foam sheathing can be installed on the underside of the cantilever.



Some contractors use the "drill and fill" method to insulate a cantilevered floor, by drilling through the bottom covering and blowing in cellulose or fiberglass insulation, then patching the holes as shown in this photo. This method does not address air flow, because the contractor doesn't open up the cantilever flooring to see if joist cavities have been blocked off between the house and the cantilever. Insulation works by trapping dead air. If the air is moving, the insulation doesn't insulate, it just filters the flowing air (Photo Source: PNNL).



Left: This cantilevered floor (viewed from the inside) does not yet have air sealing or insulation installed. (Photo source: Energy Services Group).

Right: Blocking material has been installed in the cantilever on this home and insulation is now being installed. (Photo Source: MaGrann Associates).

2009 IECC

Table 402.4.2 and 2012 IECC
Table R402.4.1.1

Floors (including above-garage and cantilevered floors): Insulation is installed to maintain permanent contact with underside of subfloor decking. Air barrier is installed at any exposed edge of insulation.

References

Natural Resources Canada. 2009. *How to Insulate Inside the Basement*, <http://oee.nrcan.gc.ca/residential/personal/new-home-improvement/choosing/insulation-sealing/basement/khi-inbasement.cfm?attr=4#top>

Advanced Energy. 2002. *Cantilevers, Technical Bulletin F2*, http://www.advancedenergy.org/buildings/knowledge_library/framing/cantilevers.pdf

ENERGY STAR. 2008. *Thermal Bypass Checklist Guide*. http://www.energystar.gov/ia/partners/bldrs_lenders_raters/downloads/TBC_Guide_062507.pdf

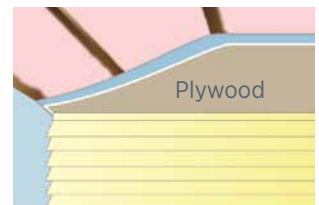
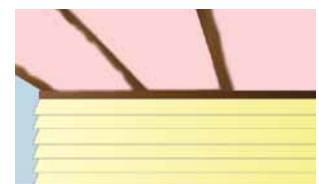
For More Information

www.buildingamerica.gov
EERE Information Center
1-877-EERE-INF (1-877-337-3463)
eere.energy.gov/informationcenter

U.S. DEPARTMENT OF
ENERGY | Energy Efficiency &
Renewable Energy

How to Air Seal and Insulate a Cantilevered Floor

- 1 Remove the exterior sheathing and any existing insulation.
- 2 Create an air barrier between the house and the cantilever by cutting a rectangle of rigid foam to fit into each floor joist bay cavity. Make a backstop for the foam by tacking furring strips to the joists at plane with the foundation or house wall.
- 3 Insert rigid foam pieces into each joist bay, nail in place and caulk to air seal all four edges.
- 4 Caulk the subfloor to the floor joists at the perimeter of the cantilevered floor and at any seams in the subfloor. Seal any wiring or piping holes through perimeter joists or subfloor with caulk or spray foam.
- 5 Install unfaced batt insulation in each floor joist bay. Use a thickness that will completely fill the cavity; it must be in contact with the top and bottom air barrier (i.e., the subfloor and rigid sheathing below) with no compressions or voids. Alternatively, spray foam each cavity with open- or closed-cell spray foam to the desired R-value.
- 6 Cover bottom of cantilever area with rigid foam insulation. Caulk the rigid foam to the joists at the edges. Tape foam at seams.
- 7 Cover rigid foam with siding or with $\frac{3}{8}$ -inch exterior plywood that is pressure-treated, painted, or primed on all exposed sides.
- 8 If you have plumbing pipes in the cantilevered floor (not recommended) and live in a cold or very cold climate, ensure adequate insulation on the exterior side of pipes to prevent freezing pipes. One option is to box in the pipes with a rigid foam box that is caulked to the subfloor to allow warmth from the house to reach the pipes.



These floor joist bays have been properly air sealed with caulked rigid foam insulation.

Improving Existing Homes: Air Sealing a Porch Wall

**BUILDING AMERICA
ENERGY PERFORMANCE BRIEF**



The house wall separating the porch attic from the rest of the house was correctly air sealed in this new home to prevent air from flowing into the home and causing heat loss.

When to Do This

Any time, if porch wall is accessible, either from the attic or from the porch.

Durability & Health

If the air barrier is missing, flowing air can carry cold air in; moisture can condense on cold surfaces causing mold.

In homes with a covered porch, the wall area hidden behind the porch ceiling may have been left open, with no air barrier and sometimes no insulation. These open areas can allow air to flow through cracks in the porch ceiling and into the home. This is especially problematic if you have a two-story house with balloon-framed walls because the joist cavity between the floors will be connected to this porch attic. This can occur even if batt insulation has been installed. If the wall sheathing is missing, air can flow through the insulation, robbing it of its thermal insulating properties.

One Building America research team led by Steven Winter Associates, investigated high-energy bill complaints at a 360-unit affordable housing development and found nearly twice the expected air leakage. Infrared scanning revealed an air leakage path on an exterior second-story wall above a front porch. They discovered that the wall between the porch and the attic had been insulated with unfaced fiberglass batts, but wall board had never been installed. The insulation was dirty from years of windwashing as wind carried dust up through the perforated porch ceiling, through the insulation, and into the wall above. Crews used rigid foam to cover and air seal the open wall area. Blower door tests showed the change reduced overall envelope leakage by 200 CFM50. The fix cost only \$267 per unit and resulted in savings of \$200 per year per unit, for a payback of less than two years.



When the wall connecting the porch to the house is properly blocked and air sealed with OSB, dry wall, or rigid foam, a significant source of air and heat loss is removed.

2009 IECC/2009 IRC Code

Requirement for New Construction and Additions

Air barrier and thermal barrier

- Exterior thermal envelope insulation for framed walls is installed in substantial contact and continuous alignment with building envelope air barrier.
- Breaks or joints in the air barrier are filled or repaired.
- Air-permeable insulation is inside of an air barrier.

References

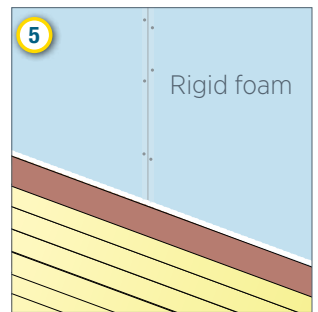
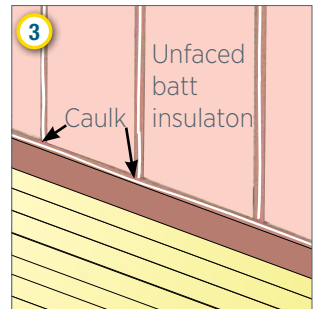
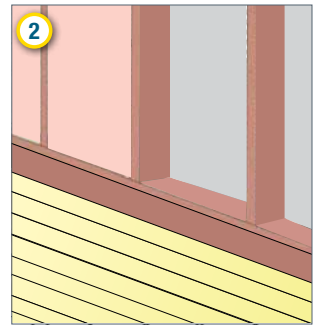
DOE. 2010. *Air Sealing*. Prepared by Pacific Northwest National Laboratory for the U.S. Department of Energy, www.buildingamerica.gov.

Moriarta, Courtney. 2008. "Fixing Air Leakage in Connecticut Town Houses," *Home Energy Magazine* July/Aug 2008, p 28-30, www.swinter.com/news/documents/FixingAirLeakage.pdf&

EPA. 2008. *ENERGY STAR Qualified Homes Thermal Bypass Checklist Guide*. U.S. Environmental Protection Agency, www.energystar.gov/ia/partners/bldrs_lenders_raters/downloads/TBC_Guide_062507.pdf

How to Air Seal a Porch Wall

- 1 Access the wall area through the porch roof or house attic.
- 2 Install insulation in the wall cavity, if none is present. If the porch wall adjoins living space, the batt insulation can be aligned with the existing drywall on the house side, before installing the air barrier on the porch side as described below. If the porch wall adjoins attic space and no air barrier is present, install an air barrier on the attic side, then install the insulation. Alternately, the air barrier can be installed on the porch side as described below and spray foam can be applied from the attic side.
- 3 Apply a thick bead of caulk to framing that will be covered.
- 4 Cut wall sheathing to fit the open space (wall sheathing rigid foam insulation, oriented strand board, or plywood). Nail or screw sheathing in place.
- 5 Caulk or spray foam around edges. If there are seams in the sheathing, seal them with caulk or tape.
- 6 Replace the porch ceiling covering.



For More Information

www.buildingamerica.gov
 EERE Information Center
 1-877-EERE-INF (1-877-337-3463)
eere.energy.gov/informationcenter

U.S. DEPARTMENT OF **ENERGY** | Energy Efficiency & Renewable Energy

Building America researchers were called to investigate high heating bills at an affordable housing project in Connecticut. Infrared camera imagery revealed high heat loss on a second-story wall above a location where a porch extended from the first-story exterior wall. Researchers opened up the perforated vinyl porch ceiling to find that there was no air barrier covering the batt insulation. Air could flow through the insulation robbing it of its heating value. An air barrier of rigid foam board was put in place with spray foam (Source: Moriarta 2008).

Improving Existing Homes: Insulating & Air Sealing Tubs

**BUILDING AMERICA
ENERGY PERFORMANCE BRIEF**



This tub was installed without a proper air barrier, such as cement backer board or rigid foam, to cover the batt insulation. The batt's paper facing doesn't form a continuous air barrier so air can flow through the wall cavity.

This robs the insulation of its heat-retaining properties and makes the tub feel cold.

When to Do This

When removing your tub or shower during a bathroom remodel.

Durability & Health

Air sealing and insulating the exterior wall behind a bathroom tub will minimize cold drafts. It will also prevent warm, moist bathroom air from escaping into the walls and attic, where it can lead to mold.

When removing your old tub or shower during a bathroom remodel, you may discover that your tub was inserted directly into an open building cavity with no drywall behind it to block air movement and no insulation to prevent heat loss. This causes drafts and cold tubs, and allows moisture from the bathroom to escape into the walls and attic, inviting mold growth.

Prior to installing your new tub or shower, have your building contractor fill the exterior wall with insulation and install an air barrier of cement backer board, rigid foam insulation, or non-paper-faced drywall. Any type of insulation may be installed as long as it completely fills the void and will be in full contact with the air barrier.

While the old tub or shower is removed, inspect the building cavity for water damage or mold. If you find moldy wood or drywall, call a mold remediation specialist. Be sure to locate the cause of the problem and repair it before installing insulation.

To guard against future moisture issues, the exterior wall behind a tub or shower should be designed to dry. Except in severely cold climates, (IECC Climate Zones 6 or higher), Building America scientists do not recommend the installation of vapor retarders in the exterior bathroom wall, nor should moisture-resistant gypsum board (green board) be used in any climate as backing for tile. Use cement backer-board instead.

2009 IECC/2009 IRC

Code Requirement for New Construction and Additions

2009 IECC 402.4.2: Shower/Tub on exterior wall: Showers and tubs on exterior walls have insulation and an air barrier separating them from the exterior wall.

2009 IECC 402.4.1: The *building thermal envelope* shall be durably sealed to limit infiltration... The following shall be caulked, gasketed, weatherstripped, or otherwise sealed with an air barrier material, suitable film or solid material: 1. All joints, seams and penetrations...8. Behind tubs and showers on exterior walls...12. Other sources of infiltration.

References

Building Science Corporation. 2009. *Info-407: Air Barriers—Tub, Shower and Fireplace Enclosures*. <http://www.buildingscience.com/documents/information-sheets/air-barriers-tub-shower-and-fireplace-enclosures>

Consortium for Advanced Residential Buildings (CARB). 2010. *High Performance Building Details: Insulation and Air Sealing II*. Prepared by Steven Winter Associates. http://carb-swa.com/articles/homepage/Air_Sealing2.pdf

Southface Energy Institute. 2009. *Residential Energy Code Field Guide*. <http://www.southface.org/default-interior/Documents/ms-field-guide-res.pdf>

U.S. Department of Energy. Accessed 9/20/11. *Bathroom Remodeling: Strategies for Energy Efficiency*. http://www.toolbase.org/PDF/DesignGuides/MDL_%205_%20Bathroom.pdf

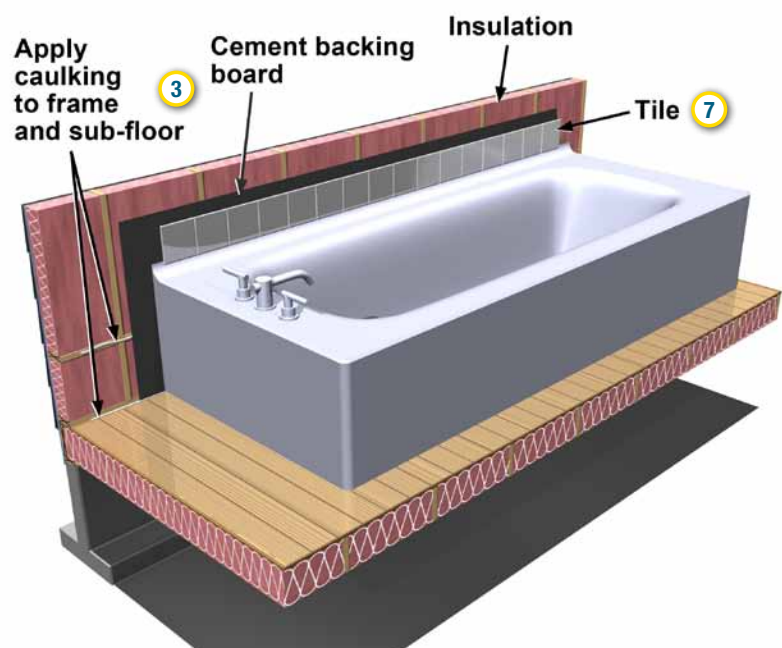
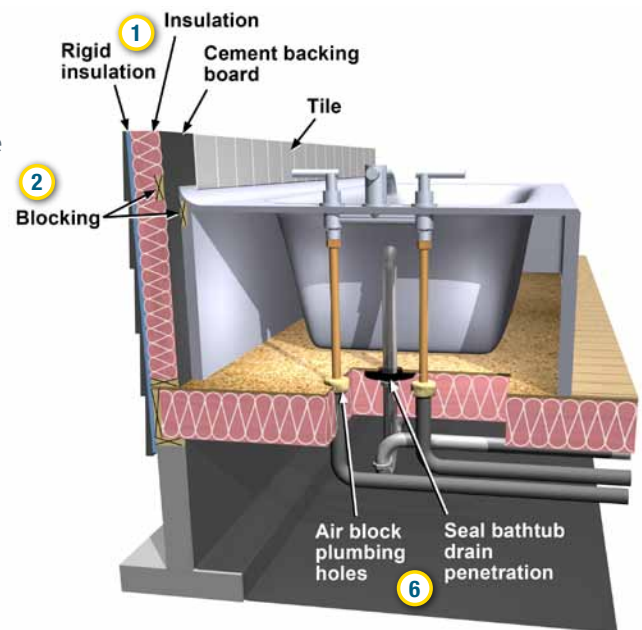
For More Information

www.buildingamerica.gov
 EERE Information Center
 1-877-EERE-INF (1-877-337-3463)
eere.energy.gov/informationcenter

U.S. DEPARTMENT OF **ENERGY** | Energy Efficiency & Renewable Energy

How to Insulate and Air Seal Behind a Tub or Shower:

- 1 Fill the entire wall cavity with insulation to the R-value required by local code or higher.
- 2 Install 2x4 blocking between the wall studs if needed to support the air barrier.
- 3 To form an air barrier: Apply a thick bead of caulk to the surface of exposed studs and wood blocking and caulk bottom plate to subfloor. Nail or screw cement board, paperless gypsum board, Thermo-Ply, or other thin barrier material to the studs.
- 4 Seal seams and any holes made through the air barrier material with caulk or foam.
- 5 Install the new tub.
- 6 Block holes around the tub drain with sheet goods and spray foam.
- 7 Finish the walls by installing fiberglass wall panels or tiling the surface.



Improving Existing Homes:**Air Sealing and Insulating
Fireplace Enclosures****BUILDING AMERICA
ENERGY PERFORMANCE BRIEF****When to Do This**

When replacing or adding a fireplace.

Durability & Health

An open wall behind an unsealed fireplace encourages drafts and pressure imbalances and could provide access for pests. If you are installing a new fireplace insert, Building America recommends a sealed insert with its own combustion air intake. Install carbon monoxide detectors in all homes that use gas or wood fireplaces.

2009 IECC/2009 IRC

*Code Requirement for New
Construction and Additions*

Insulate walls in accordance with the requirements of the 2009 IECC Table 402.1.1. Air seal in accordance with the requirements of the 2009 IECC Section 402.4.

Air that you've paid to heat or cool escapes from your home through gaps and holes, increasing your energy bills. Fireplace enclosures are common sources of air leakage that, unfortunately, are hidden from view and difficult to access for air sealing. The logical time to access and seal this area is when you remove the fireplace and replace it with a more efficient heating system.

When your fireplace is removed, you may see an open building cavity with no insulation, sheathing, or evidence of air sealing. The following instructions provide simple guidance for correcting this problem. Doing it properly will save energy, increase your comfort, and reduce the load on your heating and air conditioning systems.



Fireplaces are often installed against open framing without a proper air barrier or insulation. The arrow points to the framed exterior wall where insulation and an air barrier should be installed (Source: EnergyLogic).

References

BSC. 2009. *Air Barriers—Tub, Shower, and Fireplace Enclosures for All Climates*. Information Sheet 407. Prepared by Building Science Corporation for the U.S. Department of Energy’s Building America Program. Accessed 9/28/11. http://apps1.eere.energy.gov/buildings/publications/pdfs/building_america/tub_fireplace_enclosure.pdf

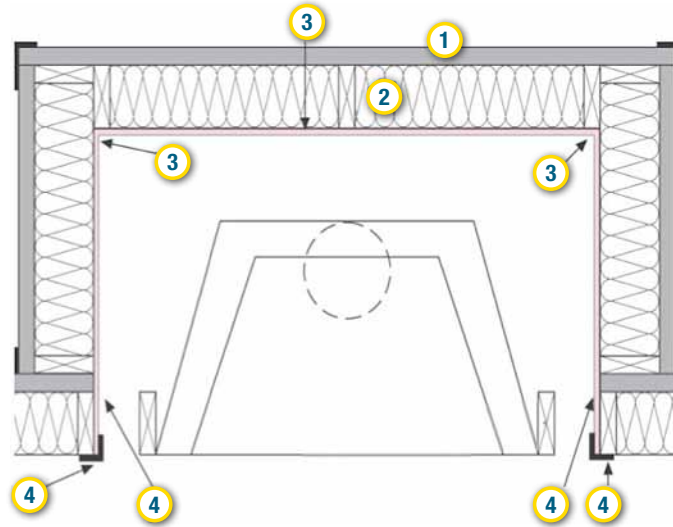
Steven Winter Associates. 2010. *High Performance Building Details: Insulation and Air Sealing II*. Prepared for U.S. Department of Energy’s Building America Program. http://apps1.eere.energy.gov/buildings/publications/pdfs/building_america/air_sealing2.pdf%20

DOE. 2010. *Building America Best Practices Series, Volume 10, Retrofit Techniques and Technologies—Air Sealing: A Guide for Contractors to Share with Homeowners*, p. 26. Prepared by the Pacific Northwest National Laboratory and Oak Ridge National Laboratory for the U.S. Department of Energy’s Building America Program. http://apps1.eere.energy.gov/buildings/publications/pdfs/building_america/ba_airsealing_report.pdf

ENERGY STAR. 2008. *Energy Star Qualified Homes: Thermal Bypass Checklist, Version 2.1*. http://www.energystar.gov/ia/partners/bldrs_lenders_raters/downloads/TBC_Guide_062507.pdf

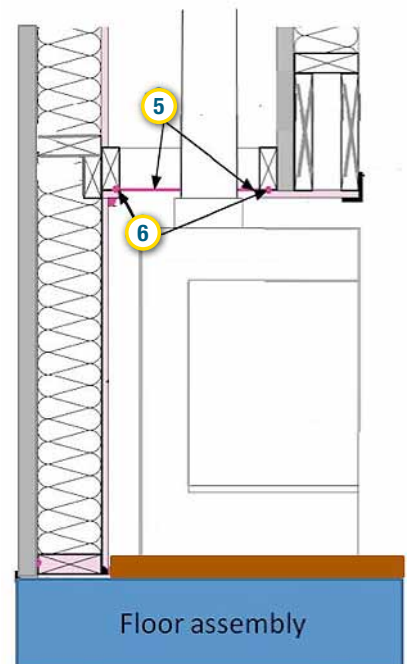
How to Insulate and Air Seal the Wall Behind your Fireplace

The diagrams shown here represent a common design for fireplace enclosures within the framed space of an exterior wall. If the design of your fireplace enclosure differs, you should be able to adapt these basic instructions to your setting.



Overhead view of fireplace enclosure (Source: Adapted from Building Science Corporation 2011)

- 1 Remove the old fireplace box.
- 2 Apply insulation (batt or spray foam) within the framing of the wall up to the ceiling/roof line.
- 3 Install a thin structural sheathing material (e.g., drywall, plywood, rigid insulation, lightweight steel or aluminum sheathing) over the new insulation. Use heat-resistant tape to seal all the seams and joints.
- 4 Tape the sheathing to the enclosure opening on both the sides and the top of the fireplace enclosure.
- 5 When the new fireplace insert and chimney are installed, seal the enclosure by placing a sheet metal firestop around the chimney pipe where it enters the chimney shaft.
- 6 Seal the joints and seams of the firestop with an approved high-temperature sealant.



Side view of fireplace enclosure (Source: Adapted from Building Science Corporation 2011)

For More Information

www.buildingamerica.gov
 EERE Information Center
 1-877-EERE-INF (1-877-337-3463)
eere.energy.gov/informationcenter



Improving Existing Homes: Insulating Plumbing Pipes

**BUILDING AMERICA
ENERGY PERFORMANCE BRIEF**



Insulating hot water pipes under kitchen and bathroom sinks and wherever else you have access to them is an easy way to save energy.

When to Do This

Any time.

Durability & Health

Insulating your water pipes reduces heat loss during water circulation, keeps pipes from sweating, and protects them from freezing during winter.

Insulating your hot and cold water pipes is inexpensive, easy to do, and will allow you to lower the temperature on your hot water heater by 2 to 4°F, saving you money (DOE 2011b). Begin by insulating the first 3 feet of pipes leading both into and out of your hot water heater; and then continue with any hot or cold water pipes that are accessible. Be sure to include pipes under your kitchen and bathroom cabinets, as well as those in a basement, crawlspace, attic, or garage. The insulation should be continuous, covering all sections of exposed pipes and fittings.

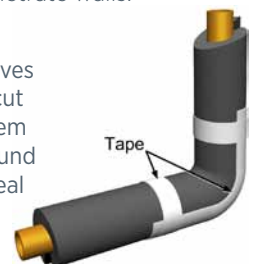
Pipe insulation is available in three forms: Tubular pipe sleeves, spiral insulation wrap, and fiberglass batts that can be taped around the pipes. If properly installed, all three can be effective.

How to Insulate Pipes Using Tubular Sleeves:

Tubular pipe sleeves are made from flexible polyethylene or neoprene foam, and come with a precut split seam that makes them easy to install by slipping them over the pipe and sealing. There are different diameters of sleeves available to accommodate the varying sizes of your pipes, so measure your pipes before purchasing. Carefully match the pipe sleeve's inside diameter to the pipe's outside diameter to ensure a snug fit.

- 1 Cut the pipe sleeve to length and wrap it around the pipe, making sure there are no gaps between sleeves.
- 2 Remove the paper strips covering the self-sealing, pre-glued seam and press the edges together, with the seam side facing down on the pipe.
- 3 Tape the seams with acrylic or aluminum foil tape to increase durability. If using more than one sleeve, tape the seam where the two sleeves meet.
- 4 Wire, tape, or clamp the insulation to the pipe every 1 to 2 feet to keep the sleeve from moving.
- 5 Use caulk or foam to seal the holes where pipes penetrate walls.

Tubular pipe sleeves come with a precut seam, making them easy to wrap around your pipes and seal (Source: DOE).



2009 IECC

Code Requirement for New Construction and Additions

2009 IECC 403.4: All circulating service hot water piping shall be insulated to at least R-2.

2012 IECC R403.4.2: Insulation for hot water pipe with a minimum thermal resistance of R-3 shall be applied to ... [most circumstances]. 2012 IECC R403.3: Mechanical system piping capable of carrying fluids above 105°F or below 55°F shall be insulated to a minimum of R-3.

References

U.S. Department of Energy. Accessed 10/7/2011. *Heat Distribution Systems*. http://www.energysavers.gov/your_home/space_heating_cooling/index.cfm/mytopic=12580

U.S. Department of Energy. Accessed 9/30/2011. *Insulate Hot Water Pipes for Energy Savings*. http://www.energysavers.gov/your_home/water_heating/index.cfm/mytopic=13060

U.S. Department of Energy. 2006. *Energy Tips-Steam: Insulate Steam Distribution and Condensate Return Lines*. <http://www1.eere.energy.gov/industry/bestpractices/pdfs/39306.pdf>


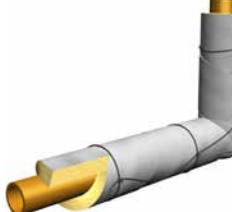
For More Information

www.buildingamerica.gov
EERE Information Center
1-877-EERE-INF (1-877-337-3463)
eere.energy.gov/informationcenter

U.S. DEPARTMENT OF
ENERGY | Energy Efficiency & Renewable Energy

How to Insulate Pipes Using Spiral Wrap or Fiberglass Batts:

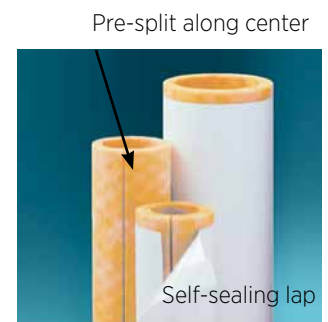
Spiral insulation wrap can be made of fiberglass, foil, or polyethylene foam. Simply unroll the material and wrap it around your hot and cold water pipes. When working with fiberglass insulation, you may need to wrap your pipes in plastic after insulating to keep the fiberglass from absorbing moisture and reducing its R-value. Most hardware stores carry fiberglass insulation plastic, or you can purchase a fiberglass insulation that already has a moisture barrier attached to it. Be sure to wear gloves, goggles, and a dust mask when installing fiberglass.

- 1 Secure the end of the spiral wrap or fiberglass batt on the pipe with tape. 
- 2 Wrap the insulation around the pipe in a spiral fashion, overlapping each successive layer by a ½-inch for tape or half the width of the batt insulation. Wrap batts as loosely as possible, as compressing them will reduce their R-value.
- 3 If using fiberglass insulation without a moisture barrier, wrap plastic around the insulated pipe and seal with tape to keep the insulation from getting wet. 
- 4 Wire, tape, or clamp the insulation (and plastic covering) to the pipe every 1 to 2 feet to keep the insulation from moving.
- 5 Use caulk or foam to seal the holes where pipes penetrate walls.

How to Insulate Steam Pipes:

If your house has a hydronic (steam or hot water) heating system, you can reduce unwanted heat loss by as much as 90% by insulating your steam distribution and return pipes (DOE 2006). Any surface over 120°F should be insulated, including boiler surfaces, steam and condensate return piping, and fittings. Use 1-inch-thick, heavy-density, resin-bonded fiberglass sleeves approved for steam or hot water heating systems, since other forms of insulation can melt. Seal and secure the fiberglass insulation sleeves with high-temperature tape. There are also removable insulation jackets that can be installed on elbows, tees, or other pipe fittings.

- 1 Measure the length of the pipe you are insulating and cut the fiberglass sleeve to match.
- 2 Open the pre-cut fiberglass sleeve by pulling on the release strip.
- 3 Fit the sleeve around the pipe and align the self-sealing lap over the sleeve.
- 4 Seal by rubbing firmly on the adhesive strip to seal the lap to the sleeve.
- 5 Wrap high-temperature tape around the pipe where two sleeves meet to minimize gaps in the insulation.



It is easy to install high-density fiberglass steam pipe insulation. Just wrap it around your hydronic pipes and seal (Source: National Institute of Building Sciences).

Improving Existing Homes:

Insulating Hot Water Heaters

**BUILDING AMERICA
ENERGY PERFORMANCE BRIEF**

When to Do This

When you have a water heater produced before 2004 or manufactured with less than R-24 insulation.

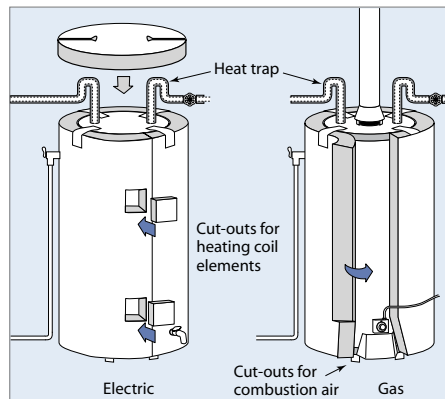
Water heating can account for 14% to 25% of the energy consumed in your home. Insulating your hot water heater is an easy and affordable way to reduce your water heating costs by 4% to 9%. Unless your water heater is already insulated to R-24 or was manufactured since 2004, you should add insulation. If you don't know your water heater's R-value, touch it. A tank that's warm to the touch needs additional insulation (DOE 2011b).

You can purchase pre-cut insulation jackets or blankets. Insulation jackets are designed to fit specific models of water heaters and simply slide on, while insulation blankets come in a single size and must be cut to fit your specific unit. Choose one with an insulating value of at least R-8. Some utilities sell them at low prices, offer rebates, and even install them at low or no cost. Your insulation kit will include insulation, belts, and tape. If directions are included, read and follow those.

When insulating your water heater, avoid setting your thermostat above 130°F. Higher temperatures can overheat the wires once the tank is insulated. For safety, never block any controls or valves and leave the thermostat access panel uncovered.

Durability & Health

Insulating a water heater extends the life of the appliance by reducing demand.



Electric and gas water heaters require different approaches to insulation. Gas and oil-fired water heaters are more difficult to insulate than electric water heaters. Their installation may be best handled by a qualified plumbing or heating contractor.

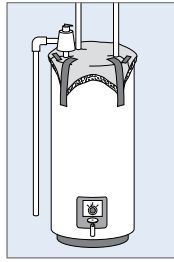
For safety, electric and gas water heaters require different approaches to insulation (Source: DOE).

2009 IECC

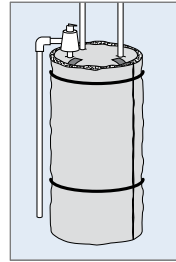
Code Requirement for New Construction and Additions

No minimum level of external insulation is prescribed in the 2009 or 2012 IECC or IRC. Per 2009 IRC PC2801.7, in Seismic Design Categories D0, D1, and D2, water heaters should be anchored to the wall with straps across the upper third and lower third of the tank to prevent tipping.

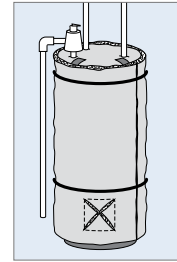
HOW TO INSULATE ELECTRIC WATER HEATERS



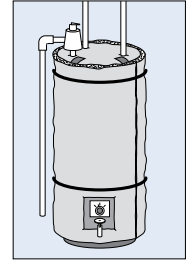
Steps 1-2



Steps 3-4



Step 5



Step 6

- 1 Cut the tank top insulation to fit around the piping on the top of the tank. Place it over the tank and tape the cut sections closed.
- 2 Fold the corners of the tank top insulation down and tape to the sides of the tank with heat-resistant tape.
- 3 Position the insulating blanket around the circumference of the tank. For ease of installation, position the blanket so that the ends do not come together over the access panels in the side of the tank. (Some tanks have only one access panel.)
- 4 Secure the blanket in place with the belts provided. Position the belts so they do not go over the access panels. Belts should fit snugly over the blanket but not compress it more than 15% to 20% of its thickness.
- 5 Locate the four corners of the access panel(s). Make an x-shaped cut in the insulating blanket from corner to corner of each access panel.
- 6 Fold the triangular flaps produced by the cuts underneath the insulating blanket. Repeat steps 5 and 6 for the rating/instruction plate.
- 7 If you are moving the water heater, you can place a piece of rigid foam insulation under the tank to reduce heat loss into the floor.
- 8 Replace or add seismic strapping as required by local code.

References

DOE. 2011a. U.S. Department of Energy. Accessed 10/3/2011. *Installing an Insulation Blanket on an Electric Storage Water Heater*. http://www.energysavers.gov/your_home/water_heating/index.cfm/mytopic=13080

DOE. 2011b. U.S. Department of Energy. Accessed 10/3/2011. *Insulate Your Water Heater Tank for Energy Savings*. http://www.energysavers.gov/your_home/water_heating/index.cfm/mytopic=13070

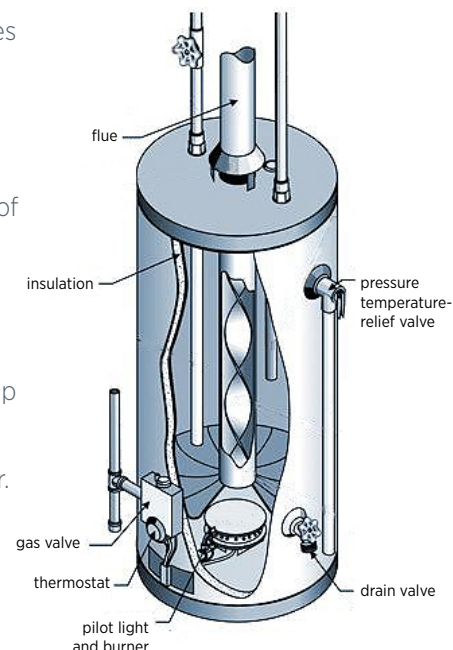
For More Information

www.buildingamerica.gov
 EERE Information Center
 1-877-EERE-INF (1-877-337-3463)
eere.energy.gov/informationcenter

U.S. DEPARTMENT OF **ENERGY** | Energy Efficiency & Renewable Energy

HOW TO INSULATE GAS- OR OIL-FIRED WATER HEATERS

- 1 Wrap the insulation blanket around the sides of the tank, cut to size, and tape in place.
- 2 To allow intake air for combustion, do not insulate below the drain valve.
- 3 Cut any excess insulation from the bottom of the tank.
- 4 Cut insulation away from the pressure-temperature relief valve, thermostat, gas valve, pilot light, and burner area. For fire safety, make sure the insulation can not drop in front of these areas.
- 5 Never insulate the top of a gas water heater. Insulating this area can result in improper venting and a possible fire hazard.
- 6 Do not install insulation underneath gas or oil-fired water heaters, where flammable liquids may leak.



Improving Existing Homes:

Keeping Wind-Blown Rain Out of Soffits

**BUILDING AMERICA
ENERGY PERFORMANCE BRIEF**



Wind-blown rain can enter attics through soffit vents during storms.

When to Do This

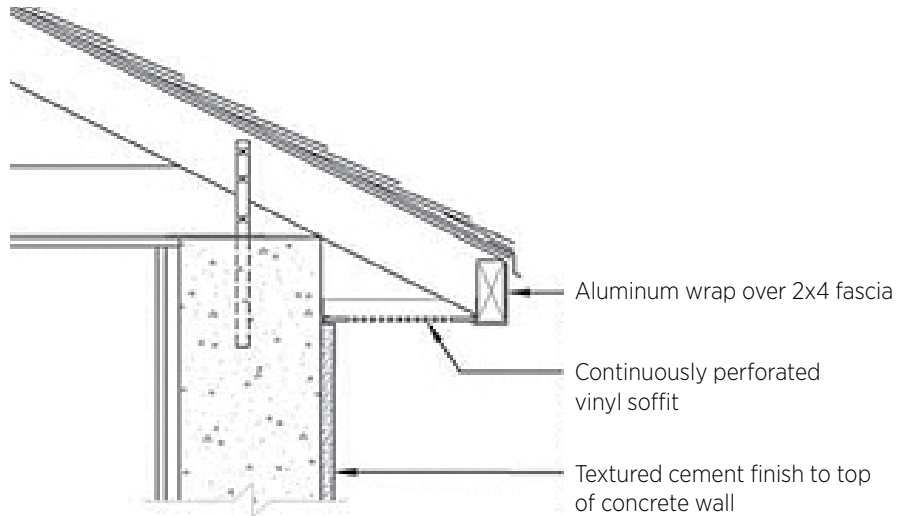
When wind-blown rain intrusion is a problem. When replacing a roof.

Durability & Health

Rain entry into attic soffit vents during high winds can cause structural damage and mold.

In hurricane-prone and high-wind coastal regions, the typical soffit design for homes is susceptible to water intrusion from direct wind pressure, suction on the lee-ward side of the house, and surface tension that draws in water sheeting off the roof that clings to the fascia and soffit.

The soffit detail for vented attics shown here discourages water draining off the roof from coming into the soffit vent openings. The improved eave design has a fascia that is extended one inch below the soffit to form a drip-edge to defeat the rain water's surface tension. The soffit vent has recessed perforations rather than vents that stick down. Additional blocking is also installed to strengthen the soffit.



Typical soffits have a fascia that is level with the bottom of the vent panel and vent perforations that face downward allowing rain water dripping down the fascia to be blown or drawn into the vent openings.

2009 and 2012 IRC R806.1

Code Requirement for New Construction and Additions

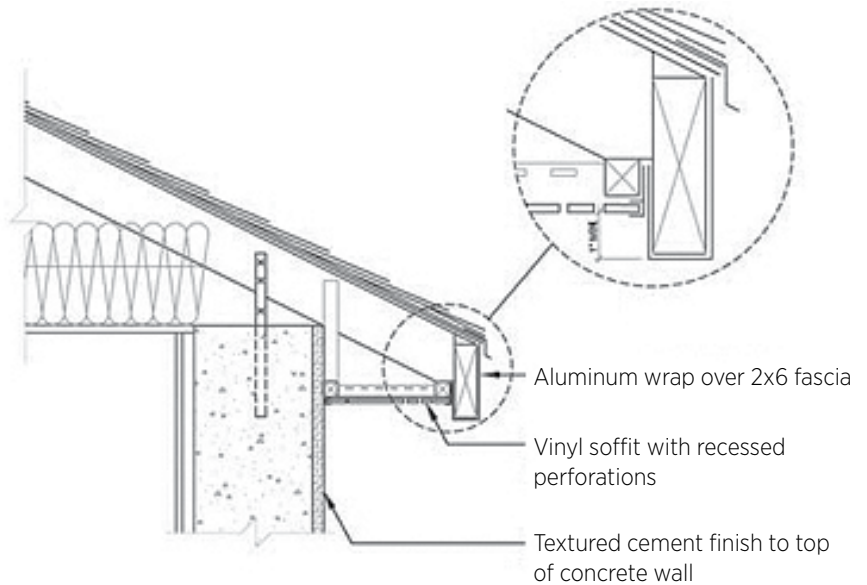
Ventilation Required. Enclosed attics ... shall have cross ventilation for each separate space by ventilating opening protected against the entrance of rain or snow.

References

DOE. 2011. *Building America Best Practices Series, Volume 15: 40% Whole-House Energy Savings in the Hot-Humid Climate*, PNNL-20768, U.S. Department of Energy. www1.eere.energy.gov/buildings/building_america/publications.htm.

Zoeller, William. 2006. "Designing and Building Hurricane-Resistant Homes," prepared by Steven Winter Associates, published in *Home Energy Magazine*, Fall 2006, www.carb-swa.com/articles/in%20the%20news/HomeEnergy_Designing%20and%20Building%20Hurricane%20Resistant%20Homes.pdf.

How to Prepare a Rain-Resistant Soffit



- 1 Replace the roof fascia with a fascia that extends one inch further.
- 2 Wrap aluminum flashing over front of fascia and extend under and up inside surface of fascia.
- 3 Install additional blocking behind fascia.
- 4 Replace the soffit vent board with soffit vent panels with recessed perforations.



The fascia was redesigned to extend 1 inch below the soffit to form a drip edge, directing water down and away from the house.



Perforated soffit board product with recessed openings was installed to limit water intrusion while encouraging greater air circulation and faster drying within the eave assembly.

For More Information

www.buildingamerica.gov
 EERE Information Center
 1-877-EERE-INF (1-877-337-3463)
eere.energy.gov/informationcenter

U.S. DEPARTMENT OF
ENERGY | Energy Efficiency &
 Renewable Energy

Installing Sidewall and Kick-out Diverter Flashing on Homes
with Rigid Foam Insulation Sheathing

**BUILDING AMERICA ENERGY
PERFORMANCE BRIEF**

Improving Existing Homes:

Installing Sidewall and Kick-out Diverter Flashing On Homes with Rigid Foam Insulation Sheathing



Improper flashing can allow rain water into walls, causing significant damage (Source: DryFlekt Products, Inc.).

When to Do This

When wall-roof intersections lack flashing or properly sized kick-out diverters.

Durability & Health

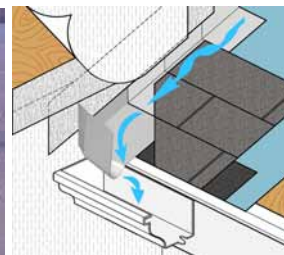
Untreated water intrusion into wall cavities can quickly lead to material damage and mold. If left untreated for too long, structural damage can result.

Deluging rains can pour thousands of gallons of water onto a home's roof in a single storm. In fact, 1 inch of rain can deposit 1,240 gallons of water on a 2,000-square foot roof. In house designs where roofs intersect walls, much of this water is channeled along the wall to a gutter. In big storm events the water can often overflow the gutter and stream down the walls. Diverters are sometime fashioned on site in an attempt to direct this water into the gutters. If undersized, these diverters are not very helpful. If not properly integrated with the existing housewrap and cladding, they can allow water to penetrate behind cladding and weather-resistant barriers. The result can be significant damage to wall sheathing, framing, and insulation and mold inside the house. While older wood siding would show evidence of this water intrusion by peeling paint, new wall claddings like fiber cement, vinyl siding and brick veneer can mask the evidence for years.

Proper flashing that is correctly integrated with housewrap and cladding along roof-wall intersections and kick-out diverters that are seamless and adequately sized to direct flowing water into the rain gutters are important tools to keep the wall cladding from being saturated by flowing water.



(Source: Steve Easley)



(Sources: DryFlekt Products, Inc.)



(Source: DryFlekt Products, Inc.)

(left) Improvised deflectors that are improperly integrated into the wall flashing and gutter are rarely sized to handle the volume of water that can run off the roof in a large downpour and they may contribute to water entry into the wall. To keep the water out, flashing should be integrated with the house wrap, siding, and shingles or roof tiles (center) and the diverter should be seamless and adequately sized to direct all of the water volume away from the wall and into the gutter (right).

Water runoff from rain storms can run along roof-wall intersections and spill over gutters to flow down exterior walls. If flashing is lacking or inadequate, this water runoff can get inside the wall and cause serious damage. Anywhere roof sections adjoin wall sections, sidewall flashing should be used to keep water from entering the walls and kick-out diverters should be used to direct the rain water into rain gutters where it can be carried down and away from the structure. The kick-out flashing should be seamless and sized as shown in the photos at right to manage large volumes of water run-off associated with torrential rains from a variety of roof pitches, with an expected service life to avoid premature failures. (Photo source: DryFlekt Products, Inc.)

Reference

DOE. 2011. *Building America Best Practices Series, Volume 15: 40% Whole-House Energy Savings in the Hot-Humid Climate*, PNNL-20768, U.S. Department of Energy. www1.eere.energy.gov/buildings/building_america/publications.htm.

2009 and 2012 IRC R703.8

Code Requirement for New Construction and Additions

Approved corrosion-resistant flashing shall be applied shingle-fashion in a manner to prevent entry of water into the wall cavity or penetration of water to the building structural framing components... flashings shall be installed at all of the following locations: ...6. At wall and roof intersections. R903.2.1 Locations. Flashings shall be installed at wall and roof intersections.... A flashing shall be installed to divert the water away from where the eave of a sloped roof intersects a vertical sidewall.

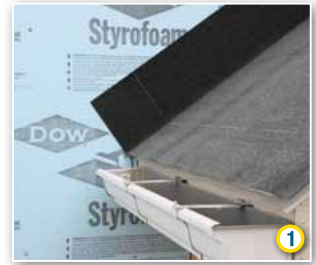
For More Information

www.buildingamerica.gov
 EERE Information Center
 1-877-EERE-INF (1-877-337-3463)
eere.energy.gov/informationcenter



How to Install Sidewall Flashing and Kick-out Diverters - On Homes with Rigid Foam Insulation Sheathing

- 1 Apply drip edge and roof underlayment over roof deck and continue lapping up the sidewall and over the water-resistive barrier (in this case rigid foam insulation) a minimum of 7 inches.
 - Install shingle starter strip at roof eave in accordance with roofing manufacturer's instructions.
 - Place seamless, one-piece, non-corrosive kick-out diverter flashing as the first piece of step flashing.
 - Slide kick-out diverter up roof plane until the starter trough stops at the shingle starter strip. Diverter must be flat on the roof and flush to the sidewall.
- 2 Fasten and seal diverter to the roof deck and starter strip. (Do not fasten to the sidewall.)
- 3 Place first shingle and next section of sidewall flashing over up-slope edge of diverter, lapping a minimum of 4" over diverter. (Sidewall flashing height requirement should be determined by design professional and local building codes.)
- 4 Install remaining sidewall flashing, appropriate counter flashing and shingles in accordance with manufacturer's instructions.
- 5 Apply self adhesive flashing over top of wall flashing, diverter and rigid foam insulation.
- 6 Apply construction tape over the self-adhered flashing. Apply siding over rigid foam insulation.



Installing Sidewall and Kick-out Diverter Flashing
on Homes with Housewrap over OSB or Plywood Sheathing

Improving Existing Homes:

Installing Sidewall and Kick-out Diverter Flashing

On Homes with Housewrap over OSB or Plywood Sheathing

**BUILDING AMERICA
ENERGY PERFORMANCE BRIEF**



Improper flashing can allow rain water into walls, causing significant damage (Source: DryFlekt Products, Inc).

When to Do This

When wall-roof intersections lack flashing or properly sized kick-out diverters.

Durability & Health

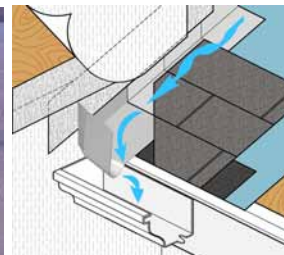
Untreated water intrusion into wall cavities can quickly lead to material damage and mold. If left untreated for too long, structural damage can result.

Deluging rains can pour thousands of gallons of water onto a home's roof in a single storm. In fact, 1 inch of rain can deposit 1,240 gallons of water on a 2,000-square foot roof. In house designs where roofs intersect walls, much of this water is channeled along the wall to a gutter. In big storm events the water can often overflow the gutter and stream down the walls. Diverters are sometime fashioned on site in an attempt to direct this water into the gutters. If undersized, these diverters are not very helpful. If not properly integrated with the existing housewrap and cladding, they can allow water to penetrate behind cladding and weather-resistant barriers. The result can be significant damage to wall sheathing, framing, and insulation and mold inside the house. While older wood siding would show evidence of this water intrusion by peeling paint, new wall claddings like fiber cement, vinyl siding and brick veneer can mask the evidence for years.

Proper flashing that is correctly integrated with housewrap and cladding along roof-wall intersections and kick-out diverters that are seamless and adequately sized to direct flowing water into the rain gutters are important tools to keep the wall cladding from being saturated by flowing water.



(Source: Steve Easley)



(Sources: DryFlekt Products, Inc.)



(Source: DryFlekt Products, Inc.)

(left) Improvised deflectors that are improperly integrated into the wall flashing and gutter are rarely sized to handle the volume of water that can run off the roof in a large downpour and they may contribute to water entry into the wall. To keep the water out, flashing should be integrated with the house wrap, siding, and shingles or roof tiles (center) and the diverter should be seamless and adequately sized to direct all of the water volume away from the wall and into the gutter (right).

Water runoff from rain storms can run along roof-wall intersections and spill over gutters to flow down exterior walls. If flashing is lacking or inadequate, this water runoff can get inside the wall and cause serious damage. Anywhere roof sections adjoin wall sections, sidewall flashing should be used to keep water from entering the walls and kick-out diverters should be used to direct the rain water into rain gutters where it can be carried down and away from the structure. The kick-out flashing should be seamless and sized as shown in the photos at right to manage large volumes of water run-off associated with torrential rains from a variety of roof pitches, with an expected service life to avoid premature failures. (Photo source: DryFlekt Products, Inc.)

Reference

DOE. 2011. *Building America Best Practices Series, Volume 15: 40% Whole-House Energy Savings in the Hot-Humid Climate*, PNNL-20768, U.S. Department of Energy. www1.eere.energy.gov/buildings/building_america/publications.htm.

2009 and 2012 IRC R703.8

Code Requirement for New Construction and Additions

Approved corrosion-resistant flashing shall be applied shingle-fashion in a manner to prevent entry of water into the wall cavity or penetration of water to the building structural framing components.... flashings shall be installed at all of the following locations: ...6. At wall and roof intersections. R903.2.1 Locations. Flashings shall be installed at wall and roof intersections.... A flashing shall be installed to divert the water away from where the eave of a sloped roof intersects a vertical sidewall.

For More Information

www.buildingamerica.gov
 EERE Information Center
 1-877-EERE-INF (1-877-337-3463)
eere.energy.gov/informationcenter

U.S. DEPARTMENT OF **ENERGY** | Energy Efficiency & Renewable Energy

How to Install Sidewall Flashing and Kick-out Diverters - On Homes with Housewrap over OSB or Plywood Sheathing

- 1 Apply drip edge and roof underlayment over roof deck. Continue lapping up the sidewall and over the weather-resistant barrier (in this case housewrap) a minimum of 6 inches.
- 2 Install shingle starter strip at roof eave in accordance with roofing manufacturer's instructions.
 - Place seamless one piece non-corrosive kick-out diverter as the first piece of step flashing.
 - Slide kick-out diverter up roof plane until the starter trough stops at the shingle starter strip. Diverter must be flat on the roof and flush to the sidewall.
 - Fasten and seal diverter to the roof deck and starter strip. (Do not fasten to the sidewall.)
- 3 Place first shingle and next section of sidewall flashing over up-slope edge of diverter, lapping a minimum of 4 inches over diverter. (Sidewall flashing height requirement should be determined by design professional and local building codes.)
- 4 Install remaining sidewall flashing, appropriate counter flashing, and shingles in accordance with manufacturer's instructions.
- 5 Apply self-adhesive flashing over top of wall flashing and diverter and housewrap.
- 6 Install house wrap. Cut the house wrap to fit over the self-adhesive flashing and sidewall flashing. Apply siding over house wrap.



Visit our Web sites at:



www.buildingamerica.gov



www.energystar.gov

Building America Program

Building America Program • 1-877-EERE-INFO (1-877-337-3463)
Office of Building Technologies, EE-2J • U.S. Department of Energy •
1000 Independence Avenue, S.W. • Washington, D.C. 20585-0121 •
www.buildingamerica.gov

National Renewable Energy Laboratory

www.nrel.gov

Oak Ridge National Laboratory

www.ornl.gov

Pacific Northwest National Laboratory

www.pnnl.gov

Research and Development of Buildings

Our nation's buildings consume more energy than any other sector of the U.S. economy, including transportation and industry. Fortunately, the opportunities to reduce building energy use—and the associated environmental impacts—are significant.

DOE's Building Technologies Program works to improve the energy efficiency of our nation's buildings through innovative new technologies and better building practices. The program focuses on two key areas:

- Emerging Technologies
Research and development of the next generation of energy-efficient components, materials, and equipment
- Technology Integration of new technologies with innovative building methods to optimize building performance and savings

Produced for the U.S. Department of Energy (DOE) by Pacific Northwest National Laboratory, Under Contract DE-AC05-76RLO 1830.

U.S. DEPARTMENT OF
ENERGY

Energy Efficiency &
Renewable Energy

eere.energy.gov

For information on **Building America** visit www.buildingamerica.gov. The website contains expanded case studies, technical reports, and best practices guides.

PNNL-20972 • May 2012