



Lawrence Berkeley Laboratory

UNIVERSITY OF CALIFORNIA

Materials & Molecular Research Division

Submitted to the Journal of Applied Physics

SATURATION OF ABSORPTION IN p-GE USING PICOSECOND
CO₂ LASER PULSES

H. S. Kwok

January 1980

RECEIVED
LAWRENCE
BERKELEY LABORATORY

APR 25 1980

LIBRARY AND
DOCUMENTS SECTION

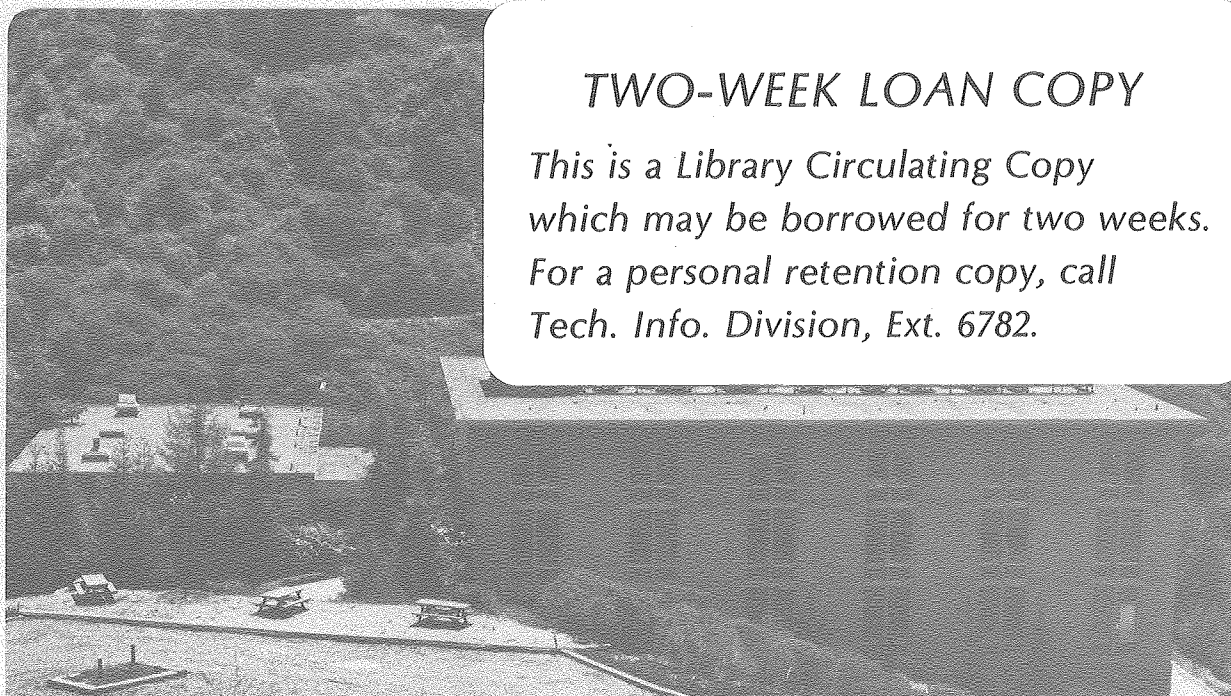

TWO-WEEK LOAN COPY

*This is a Library Circulating Copy
which may be borrowed for two weeks.
For a personal retention copy, call
Tech. Info. Division, Ext. 6782.*

LBL 10491 c.2

DISCLAIMER

This document was prepared as an account of work sponsored by the United States Government. While this document is believed to contain correct information, neither the United States Government nor any agency thereof, nor the Regents of the University of California, nor any of their employees, makes any warranty, express or implied, or assumes any legal responsibility for the accuracy, completeness, or usefulness of any information, apparatus, product, or process disclosed, or represents that its use would not infringe privately owned rights. Reference herein to any specific commercial product, process, or service by its trade name, trademark, manufacturer, or otherwise, does not necessarily constitute or imply its endorsement, recommendation, or favoring by the United States Government or any agency thereof, or the Regents of the University of California. The views and opinions of authors expressed herein do not necessarily state or reflect those of the United States Government or any agency thereof or the Regents of the University of California.

SATURATION OF ABSORPTION IN p-Ge USING
PICOSECOND CO₂ LASER PULSES

H.S. Kwok

Gordon McKay Laboratory
Harvard University
Cambridge, Massachusetts 02138

and

Materials and Molecular Research Division*
Lawrence Berkeley Laboratory
Berkeley, California 94720

JANUARY 1980

ABSTRACT

A time-resolved measurement on the recovery of saturation in p-Ge was performed with picosecond CO₂ laser pulses. It was directly confirmed that the relaxation of hole excitation in p-Ge was faster than 40 psec and that this type of measurement can provide additional temporal information on picosecond pulses.

*Present address.

INTRODUCTION

p-type germanium is a common saturable absorber at the CO₂ laser wavelengths. It has been well-established that its dominant absorption mechanism is by direct heavy to light hole valence band transitions,¹ with a large absorption cross-section of $6.8 \times 10^{-16} \text{ cm}^2$. In the past, it has been successfully used as a passive mode-locker for the CO₂ laser,² and as a broadband interstage isolator for high power laser chains.³ The saturation mechanism in p-Ge has been demonstrated to be inhomogeneous and it has been indirectly shown that the saturation of absorption recovers on a picosecond timescale from a spectral hole-burning measurement.⁴

In this paper we describe a time-resolved saturation measurement in p-Ge using picosecond CO₂ laser pulses. It is shown directly that the saturation recovery in p-Ge is indeed on a picosecond timescale and that it can be employed as a method for measuring short laser pulse durations.

EXPERIMENT I

The generation of picosecond CO₂ laser pulses using optical free induction decay has been described adequately previously.⁶ Briefly, an ordinary TEA laser pulse is rapidly truncated in 10 psec, and the fast component of the truncated pulse is then filtered out by using a resonant absorber. This high frequency component manifests itself in the time domain as an ultrafast short pulse.

In the first experiment, we made use of both the truncated pulse and the generated picosecond pulse. The experimental arrangement is shown in Fig. 1. The laser system consisted of a hybrid type high pressure TEA and low pressure gain sections⁷ to obtain a smooth single longitudinal mode 100 nsec laser pulse without any mode beating. The laser pulse is truncated by a gas breakdown plasma switch⁸ in 10 psec. The breakdown can be triggered precisely by a d.c. electrical spark with no appreciable jitter.⁹ The truncated pulse is then split into two channels. One channel was focussed onto a p-Ge sample with a variable time delay. The other channel was sent through a 700°K tube filled with 250 torr of CO₂ gas. A picosecond pulse was produced at the output of the hot CO₂ gas tube and was focused onto the p-Ge as a probe. The transmitted probe pulse was detected by a cooled Ge: Au detector and integrated by a slow amplifier.

The sample was a piece of polycrystalline p-Ge doped to 0.5 Ω-cm. It has both faces polished but not coated. This might create a problem of standing waves inside the crystal. However, since absorption by the holes in the semiconduction was high, and that the pump and probe channels were not exactly collinear, standing wave effects were minimized.

The focussing of the truncated pulse channel was rather gentle to avoid any laser induced damage of the sample. The estimated intensity of the pump beam was 28 MW/cm² which was much larger than the saturation intensity of 3.2 MW/cm² as measured by Phipps et al.³ The probe channel had to be attenuated in order to avoid any saturation effects of its

own. However, because of the short pulse duration and hence the small pulse energy of the probe, it could not be attenuated too much before getting into detection problems. In the experiment, we found that there was a slight saturation due to the probe pulse. The transmission of the probe pulse was 9% instead of 5.3% measured with a much weaker nanosecond pulse.

In Fig. 2 we plot the transmission of the probe pulse at the presence of the pumping truncated pulse as a function of the time delay between them. It can be seen that when the two pulses overlap in time, which is towards the left hand side of Fig. 2, the transmission of the probe pulse is 22%. This is due to the strong absorption saturation by the pump pulse. As the delay is increased, the transmission of the probe pulse decreases rapidly to its small signal value of 9%. This corresponds to the case when the two pulses do not overlap in time at all. The recovery of saturation in Fig. 2 can be nicely fitted with an exponential time constant of 40 ± 5 psec. Let us examine what this recovery time means physically.

From the analysis of Brown and Bray,¹⁰ the dominant relaxation mechanism for the excited holes in p-Ge are inelastic by acoustic and optical phonons, and by ionized impurities. Keilmann included hole-hole scattering and also scattering by neutral impurities in his discussion on the various lifetimes of the excited holes.¹ The results are that only lattice scattering is important in the relaxation process, with scattering times of 0.97 psec and 1.25 psec respectively for optical and acoustic phonons at room temperature.

It has been shown that⁶ the free induction decay pulse can be approximated by a rapid rise on the order of 10 psec and then followed by an exponential fall with a time constant of $T_2/\alpha L$ where T_2 is the dephasing time of the hot CO_2 molecules and αL is the absorption of the CO_2 laser by the hot CO_2 gas tube. The interpretation of the experimental measurement represented in Fig. 2 is rather complicated since it involves the convolution of the transmitted pump pulse with the probe pulse. But physically the truncated pulse can be regarded as a step function so that we are basically convoluting the fast decay edge of the truncated pump probe with the $T_2/\alpha L$ decay tail of the picosecond probe pulse. It is interesting to find that the observed falltime agrees quite well with the calculated value of 45 psec for $T_2/\alpha L$. Therefore, the recovery of saturation in Fig. 2 should not be due to the relaxation effect in p-Ge but rather comes from the finite pulse duration of the pulses used.

EXPERIMENT II

In the second experiment, we sent the entire truncated TEA laser pulse through the hot CO_2 absorption cell to generate a single picosecond pulse with 4 MW peak power. This picosecond pulse was split into two channels in the usual pump and probe arrangement. The two channels were of different intensity with the stronger pulse acting as a pumping channel with variable time delay. The weaker probe channel was detected and integrated as in experiment I. A box-car

integrator was used for data averaging and the scanning of the pump channel was done automatically with a controlled speed motor.

This experiment was basically the same as experiment I except that instead of a step function the pump pulse was replaced by another picosecond pulse. Figure 3 represents the result of such a measurement. We observed that there was a factor of two increase in the transmission of the probe pulse as induced by the pump pulse.

In this experiment, both the pump and probe pulses were focussed onto the sample by the same 5 inch focal length lens. Therefore the degree of induced transmission depends quite sensitively on the spatial overlap of the two pulses. Unlike the previous experiment, the zero of time delay can be exactly located because the two pulses have the same shape. The measured FWHM was 55 psec for a CO₂ gas cell pressure of 250 torr. In the next section, we shall discuss the interpretation of the experimental results and also point out some of the applications of these experiments.

DISCUSSION

In order to interpret the saturation curves obtained in Fig. 2 and 3, let us look at the equations governing the propagation of the two pulses through the absorbing medium. Let $I_p(z,t)$ and $I(z,t)$ be the probe and pump intensity as a function of position and time. Then for an inhomogeneously broadened absorber, and for the case where the relaxation time is much shorter than the laser pulse duration,

$$\frac{\partial I(z,t)}{\partial z} = -\alpha I(z,t) / \sqrt{(1 + I(z,t)/I_s)} \quad (1)$$

$$\frac{\partial I_p(z,t)}{\partial z} = -\alpha I_p(z,t) / \sqrt{(1 + I(z,t)/I_s)} \quad (2)$$

where α , I_s are the small signal absorption coefficient and saturation intensity respectively. In general, to obtain a solution of $I_p(z,t)$, we have to solve (1) first, and then use the solution to $I(z,t)$ to solve (2). Obviously this is analytically impossible to perform. But we can observe that from (1), (2)

$$\frac{1}{I_p(z,t)} \frac{\partial I_p(z,t)}{\partial z} = \frac{1}{I(z,t)} \frac{\partial I(z,t)}{\partial z} \quad (3)$$

This equation implies that $I_p(z,t)$ and $I(z,t)$ are proportional to each other

$$I_p(z,t) = C(t) I(z,t) \quad (4)$$

The constant of proportionality $C(t)$ can be obtained explicitly by invoking the initial condition at the entrance surface of the crystal. Let the pulse shape function of the probe pulse and the pump pulse be $f_p(t)$ and $f(t)$ respectively, and that the time delay between them be τ , then

$$f_p(t) = C(t) f(t + \tau) \quad (5)$$

and therefore

$$I_p(z,t) = f_p(t) \frac{I(z,t + \tau)}{f(t + \tau)} \quad (6)$$

Thus once the solution to equation (1) is found,¹¹ the transmitted probe pulse can be obtained immediately without solving (2). The physical interpretation of (6) is straightforward. The function $I(z,t + \tau)/f(t + \tau)$ is just the transmission function of the saturable absorber $T(t + \tau)$ which is determined by the pump pulse instantaneous intensity. Therefore (6) simply means that the transmitted probe pulse is given by $T(t + \tau)$ multiplied by the input intensity of the probe pulse. Notice that (3) and hence (6) are not valid when $I(z,t)$ is equal to zero. In that case $T(t + \tau)$ should be replaced by the small signal transmission value of the sample. In the following, let us examine some salient features of the experimentally observed data with the help of equation (6).

First of all, since the detection system cannot time resolve the picosecond CO_2 pulses used in the experiment, the observed signal $S(\tau)$ must therefore be time-integrated. Hence

$$S(\tau) = \int_0^{\infty} dt f_p(t) T(t + \tau) \quad (7)$$

i.e., experimental curves in Fig. 2 and Fig. 3 are simply the convolution function of the picosecond CO_2 pulse with the transmission function $T(t)$.

For experiment I, as pointed out in the experimental section, $T(t)$ can be taken as a step function and the signal obtained is a direct

measure of the $T_2/\alpha L$ falling edge of the free induction decay pulse. As mentioned above, the experimental fall time of 40 ± 5 psec is in good agreement with the calculated value of 45 psec for $T_2/\alpha L$.

For experiment II, the two pulse shape functions for both the pump pulse and the probe pulse are the same. However, the transmission function $T(t)$ is in general quite different from the original pulse shape. In particular its width may be narrower or wider than $f(t)$ depending on whether the system is slightly or strongly saturated. Also since (7) is not symmetrical in τ , the measured convolution function is therefore asymmetric in time delay. The measured FWHM on Fig. 3 is 55 psec. The corresponding autocorrelation function of the picosecond pulse under the same conditions was measured to be 32 psec.⁵ This is an indication that we are strongly saturating the absorption in p-Ge.

Let us discuss here the usefulness of the induced transmission method as applied to the measurement of picosecond pulse durations. The saturation methods described in this paper do not yield the first order autocorrelation as in the two photon fluorescence¹² or second harmonic method.⁵ Instead they provide correlation functions with some other pulses. In particular, the arrangement in experiment I gives the correlation function of the picosecond pulse with a step function. Therefore it is a valuable method of extracting temporal information about the picosecond pulse.

This method is not limited to 10.6μ only since fast saturable absorbers exist for other frequency ranges. The other requirement

for this type of measurement is the ability to generate a step function using a gas breakdown plasma. This is not a serious problem since most picosecond laser systems are capable of inducing gas breakdowns. For example, it would be interesting to repeat this experiment with a mode-locked Nd:Yag laser in a saturable dye solution. This should provide more information on the temporal characteristics of such laser pulses.

Another application of the induced transmission method has been demonstrated recently in the measurement of the picosecond intramolecular vibrational energy transfer time in SF_6 .¹³ In such picosecond pulse experiments, it is often necessary to have a pump and probe arrangement. Putting in a known fast saturable absorber instead of the sample not only provides us with an idea of the system time-resolution, it also clearly defines the zero of time delay which cannot be obtained accurately otherwise.

CONCLUSION

We would like to emphasize here the general applicability of picosecond CO_2 laser pulses to solid state physics experiments. Because of the high peak power and small energy content, picosecond pulses are an idea for the study of solid state interactions at high light intensities.¹⁴ For example, the saturation experiment in p-Ge as a function of laser intensity could easily be extended to over 1 GW/cm^2 without procuring material damage. It is a desirable advantage because only at very high

Laser intensities, can inhomogeneous and homogeneous broadening mechanisms be distinguished.³

In conclusion, we have directly demonstrated the fast dephasing and depopulation in p-Ge. Moreover, we turned the coin around and found that the general method of induced saturation can be quite useful in characterizing picosecond pulses.

The author would like to thank Professors E. Yablonovitch and N. Bloembergen for their guidance, and Professor Y. R. Shen for commenting on the manuscript. The work was partially supported by the Joint Service Electronics Program at Harvard University and by the Division of Chemical Sciences, Office of Basic Energy Sciences, U.S. Department of Energy under contract No. W-7405-Eng-48.

REFERENCES

1. F. Keilmann, IEEE J. Quant. Electron. QE-12, 592 (1976).
2. A. F. Gibson, M. F. Kimmitt and B. Norris, Appl. Phys. Lett. 24, 306 (1974); A. J. Alcock and A. C. Walker, Appl. Phys. Lett. 25, 299 (1974); P. Larigue, J. Gilbert and J. L. Lachambre, Opt. Comm. 14, 194 (1975); R. S. Taylor, B. K. Garside and E. A. Ballik, IEEE J. Quant. Electron. QE-14, 532 (1978).
3. C. R. Phipps and S. J. Thomas, Opt. Lett. 1, 93 (1977).
4. F. Keilmann, Appl. Phys. 14, 29 (1977).
5. H. S. Kwok and E. Yablonovitch, Appl. Phys. Lett. 30, 158 (1977).
6. H. S. Kwok and E. Yablonovitch, Rev. Sci. Instr. 46, 814 (1975); H. S. Kwok, Ph.D. Thesis, Harvard University, 1978 (unpublished).
7. A. Gondhalekar, N. R. Heckenberg and E. Holzhauser, IEEE J. Quant. Electron. QE-11, 103 (1975).
8. H. S. Kwok and E. Yablonovitch, Opt. Comm. 21, 252 (1977).
9. H. S. Kwok and E. Yablonovitch, Appl. Phys. Lett. 27, 583 (1975).
10. D. M. Brown and R. Bray, Phys. rev. 127, 1593 (1962).
11. W. W. Rigrod, J. Appl. Phys. 34, 2602 (1963).
12. D. J. Bradley and G. H. C. New, Proc. IEEE 62, 313 (1974).
13. H. S. Kwok and E. Yablonovitch, Phys. Rev. Lett. 41, 745 (1978).
14. H. S. Kwok, Nonlinear absorption and reflection in n-InSb during short pulse durations, Annual Report to the Advance Research Projects Agency, Division of Engineering and Applied Physics, Harvard University, 1977.

FIGURE CAPTIONS

- Fig. 1. Experimental arrangement employing the truncated TEA laser pulse as a pump source and the picosecond free induction decay pulse as a probe. Attenuators and filters are not shown.
- Fig. 2. Induced transmission of the p-Ge sample as a function of the time delay between the two pulses. The exponential fall time is 40 ± 5 psec.
- Fig. 3. Saturation of absorption recovery scan using both picosecond pulses as pump and probe. FWHM of this trace is 55 psec. See text for a discussion of this measured width.

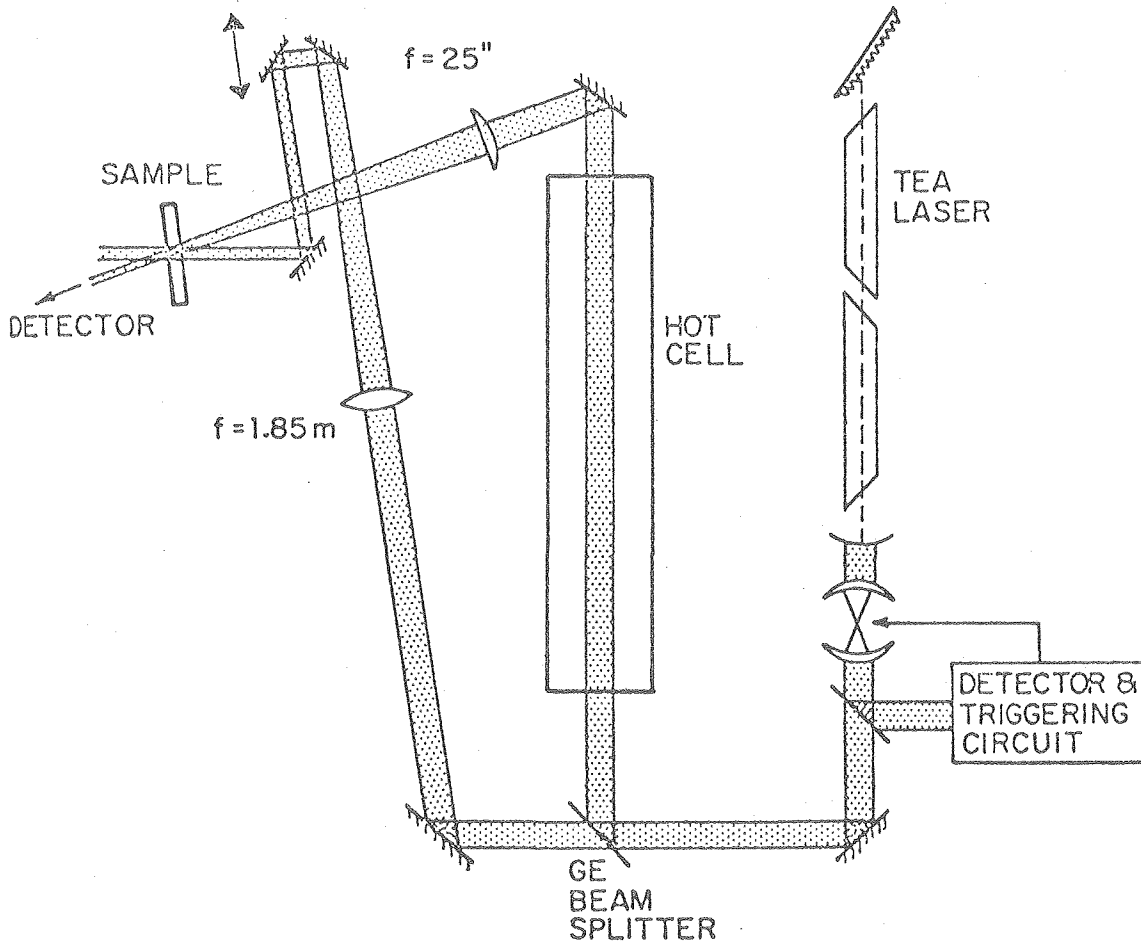

XBL 802-7929

Fig. 1

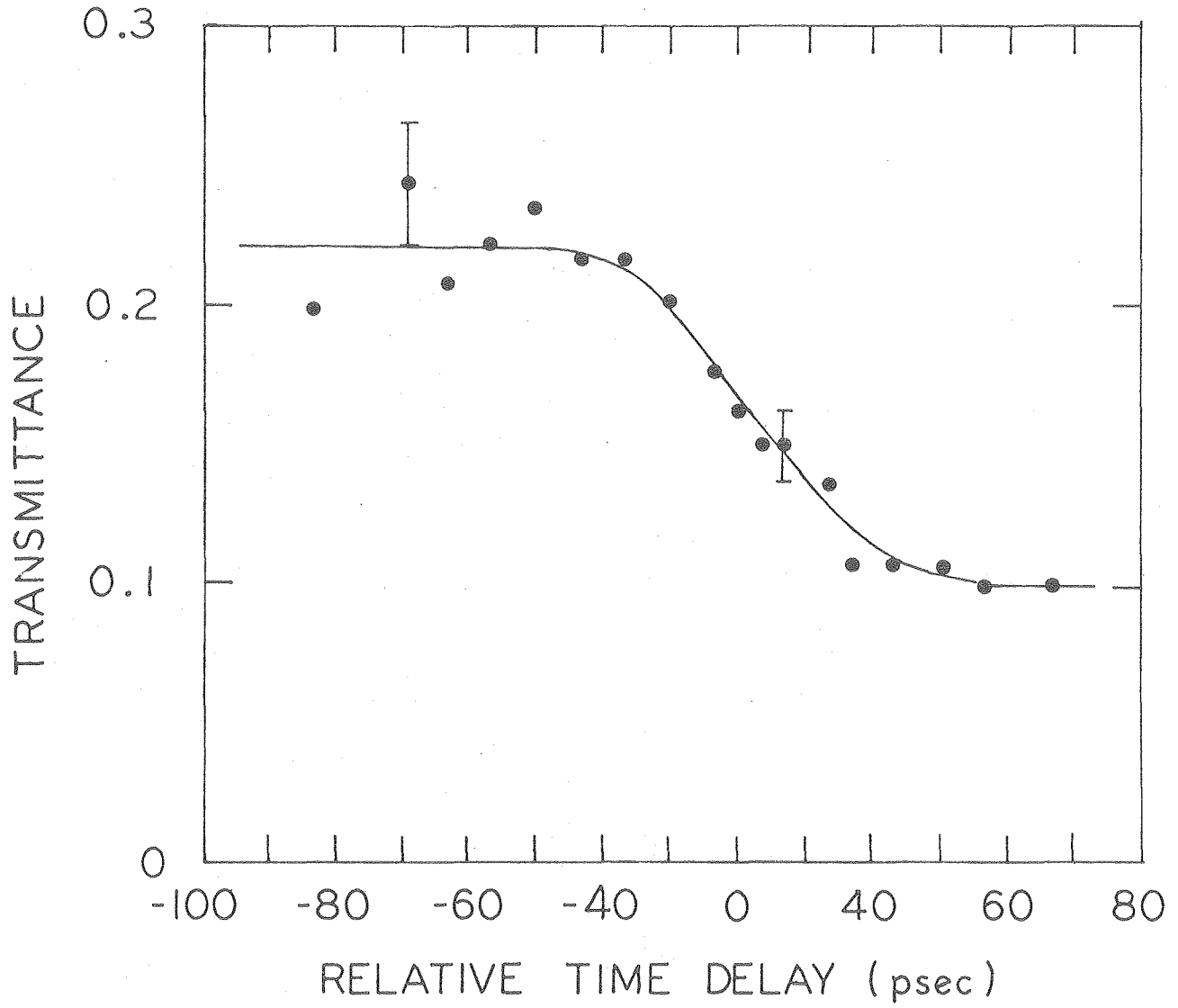

XBL 802-7928

Fig. 2

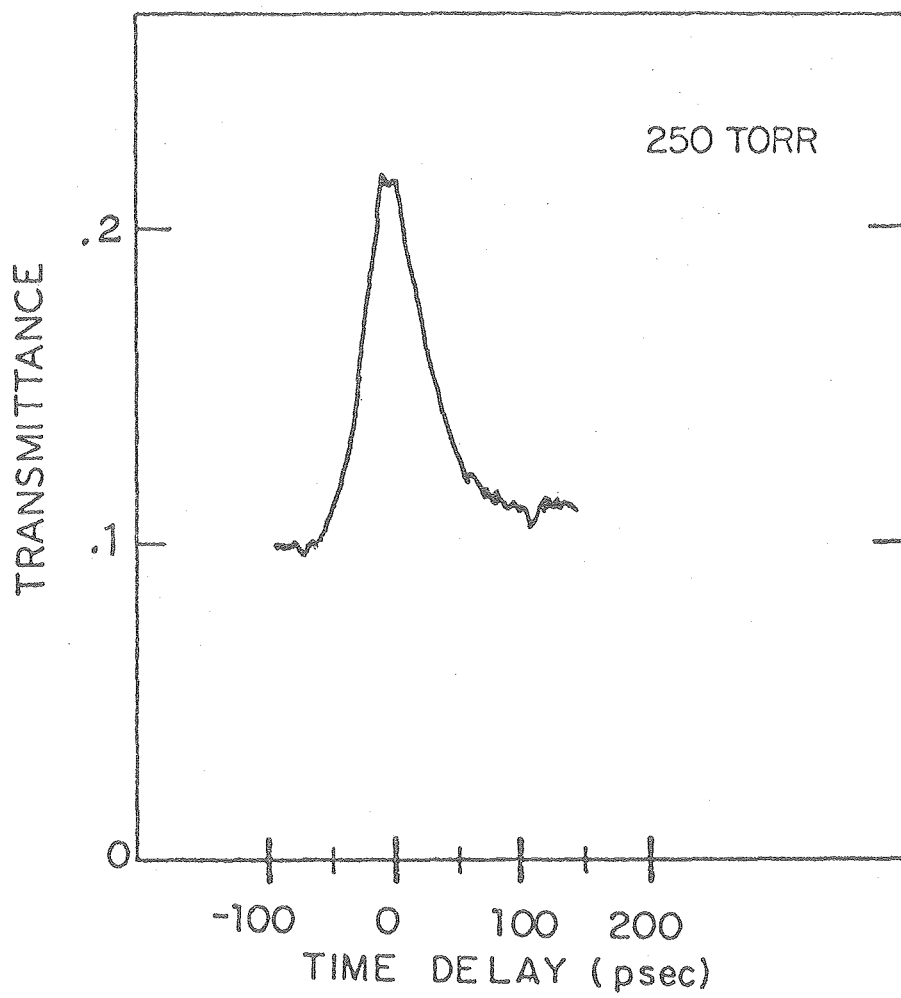

Fig. 3

XBL 802-7930