

Superconducting 112 MHz QWR electron gun

**S. Belomestnykh¹, I. Ben-Zvi^{1,2}, C.H. Boulware³, X. Chang¹,
T.L. Grimm³, T. Rao¹, B. Siegel³, J. Skaritka¹, R. Than¹,
M. Winowski³, Q. Wu¹, T. Xin^{1,2}, L. Xue^{1,2}**

¹⁾ Brookhaven National Laboratory, Upton, NY 11973, U.S.A.

²⁾ Stony Brook University, Stony Brook, NY 11794, U.S.A.

³⁾ Niowave, Inc., Lansing, MI 48906, U.S.A.

*Presented at the 15th International Conference on RF Superconductivity
(SRF2011)
Chicago, Illinois
July 25 – 29, 2011*

Collider-Accelerator Department

Brookhaven National Laboratory

**U.S. Department of Energy
DOE Office of Science**

Notice: This manuscript has been authored by employees of Brookhaven Science Associates, LLC under Contract No. DE-AC02-98CH10886 with the U.S. Department of Energy. The publisher by accepting the manuscript for publication acknowledges that the United States Government retains a non-exclusive, paid-up, irrevocable, world-wide license to publish or reproduce the published form of this manuscript, or allow others to do so, for United States Government purposes.

This preprint is intended for publication in a journal or proceedings. Since changes may be made before publication, it may not be cited or reproduced without the author's permission.

DISCLAIMER

This report was prepared as an account of work sponsored by an agency of the United States Government. Neither the United States Government nor any agency thereof, nor any of their employees, nor any of their contractors, subcontractors, or their employees, makes any warranty, express or implied, or assumes any legal liability or responsibility for the accuracy, completeness, or any third party's use or the results of such use of any information, apparatus, product, or process disclosed, or represents that its use would not infringe privately owned rights. Reference herein to any specific commercial product, process, or service by trade name, trademark, manufacturer, or otherwise, does not necessarily constitute or imply its endorsement, recommendation, or favoring by the United States Government or any agency thereof or its contractors or subcontractors. The views and opinions of authors expressed herein do not necessarily state or reflect those of the United States Government or any agency thereof.

SUPERCONDUCTING 112 MHZ QWR ELECTRON GUN*

S. Belomestnykh^{#,1}, I. Ben-Zvi^{1,2}, C.H. Boulware³, X. Chang¹, T.L. Grimm³, T. Rao¹, B. Siegel³,
J. Skaritka¹, R. Than¹, M. Winowski³, Q. Wu¹, T. Xin^{1,2}, L. Xue^{1,2}

¹) Brookhaven National Laboratory, Upton, NY 11973-5000, U.S.A.

²) Stony Brook University, Stony Brook, NY 11794, U.S.A.

³) Niowave, Inc., Lansing, MI 48906, U.S.A.

Abstract

Brookhaven National Laboratory and Niowave, Inc. have designed and fabricated a superconducting 112 MHz quarter-wave resonator (QWR) electron gun. The first cold test of the QWR cryomodule has been completed at Niowave. The paper describes the cryomodule design, presents the cold test results, and outline plans to upgrade the cryomodule. Future experiments include studies of different photocathodes and use for the coherent electron cooling proof-of-principle experiment. Two cathode stalk options, one for multi-alkali photocathodes and the other one for a diamond-amplified photocathode, are discussed.

INTRODUCTION

A quarter-wave resonator concept of superconducting RF (SRF) electron gun was proposed at BNL for electron cooling hadron beams in RHIC [1, 2]. QWRs can be made sufficiently compact even at low RF frequencies (long wavelengths). The long wavelength allows to produce long electron bunches, thus minimizing space charge effects and enabling high bunch charge. Also, such guns should be suitable for experiments requiring high average current electron beams.

A 112 MHz QWR gun was designed, fabricated, and cold-tested in collaboration between BNL and Niowave [3]. This is the lowest frequency SRF gun ever tested successfully. In this paper we describe the gun design and fabrication, present the cold test results, and outline our plans. This gun will also serve as a prototype for a future SRF gun to be used for coherent electron cooling of hadrons in eRHIC.

112 MHZ GUN DESIGN AND FABRICATION

The cavity geometry was designed using Superfish [4]. Figure 1 shows the model used to calculate the cavity RF parameters, summarized in Table 1. Since the fields will appear nearly electrostatic, a Pierce-type geometry (recessed cathode, as shown in the figure) can be used to focus the beam and compensate for the space charge of the high intensity electron beam. The Pierce electrode shape has higher electric fields away from the cathode, but these field levels are controlled in the design.

* Work is supported by Brookhaven Science Associates, LLC under Contract No. DE-AC02-98CH10886 with the U.S. DOE. Work at Stony Brook University is supported under grant DE-SC0005713 with the U.S. DOE. Work at Niowave is supported by the U.S. DOE under SBIR contract No. DE-FG02-07ER84861

[#]sbelomestnykh@bnl.gov

Table 1: RF parameters of the 112 MHz SRF gun cavity

Parameter	Value
Frequency	112 MHz
R/Q (linac definition)	126 Ohm
Geometry factor G	38.2 Ohm
Quality factor Q_0 w/o cathode insert	$> 3.5 \times 10^9$
Operating temperature	4.5 K
E_{pk}/V_{acc}	19.1 m^{-1}
E_{pk}/E_{cath}	2.63
B_{pk}/V_{acc}	36.4 mT/MV
Length	1.1 m
Aperture	0.1 m
Maximum diameter	0.42 m

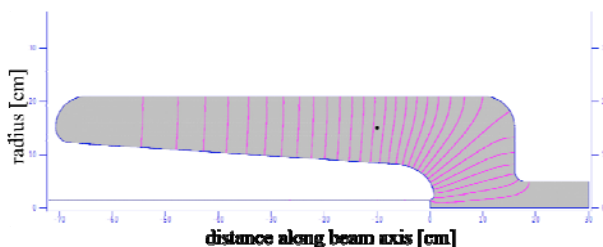

Figure 1: Cavity geometry used in Superfish calculations.

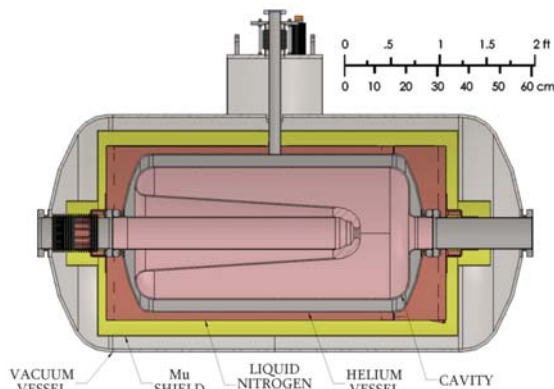

Figure 2: 112 MHz electron gun cryomodule.

The complete cryomodule design is shown in Figure 2. The niobium cavity in a helium vessel is surrounded by the superinsulation, liquid nitrogen shield, another layer of superinsulation, and magnetic shield (mu metal).

Electron beam welding included four cycles: welding the niobium beam tube; welding of the inner and outer conductor halves; welding the subassembly; completing all niobium welding of the cavity shown in Figure 3.



Figure 3: Electron beam welded 112 MHz Nb cavity.

The stainless steel helium vessel was welded onto the cavity prior to chemical etching of niobium and acted as a cooling jacket. The cavity was chemically etched and high pressure rinsed in the Class 100 cleanroom. The cryomodule's vacuum vessel is made from low carbon steel. The vessel is demagnetized and acts as a magnetic shield. Due to the size of this cavity, testing in the cryomodule was easier and more efficient than trying to carry out an intermediate test before cryomodule assembly. The cavity was hermetically sealed in the cleanroom with the cathode assembly, power coupler, pick-up probe and beamline vacuum components. Once the cryomodule was complete, it was vacuum leak checked and cold shocked with liquid nitrogen.

FIRST COLD TEST

The cooldown began with opening liquid nitrogen supply to the thermal shield. It was cooled stably overnight with exhaust gas from the shield tubes at approximately 150 K. This procedure cooled the cavity flanges to just below 200 K. This was followed by the liquid nitrogen pre-cool of the helium vessel. The cavity flanges were cooled at a rate of 10 K/min down to around 130 K, with the temperature monitors on the vessel itself reaching 100 K in about 2 hours. The switchover to liquid helium took place after that. The cavity flanges were cooled at a rate of 2 K/min from 130 K to 10 K, limiting the time in the “ Q disease” range. The liquid helium vessel sensor reached 4.4 K in approximately one hour and the liquid helium vessel was full in 1.5 hours. In summary, the cavity was cooled to the superconducting transition in approximately 3.5 hours from the beginning of the liquid nitrogen pre-cool. The efficiency of the cavity cooldown (in terms of time and liquid helium lost to boiling) was therefore excellent.

For this test, a copper cathode rod was also used as a fundamental RF power coupler (FPC) as shown in Figure 4. An external (to the cryomodule) RF network

was used for fine-tuning the coupling and search for resonant modes. The fundamental cavity mode was observed at 113.0 MHz within 2 hours of the cooldown. The difficulty in locating the mode frequency was due to the extremely narrow bandwidth of the mode. The “ $5\lambda/4$ ” mode was also observed at high Q and located at 476.5 MHz. The adjustability of the coupling to the fundamental mode was measured by changing the position of the cathode and observing the loaded Q of the cavity. Results are shown in Figure 5.

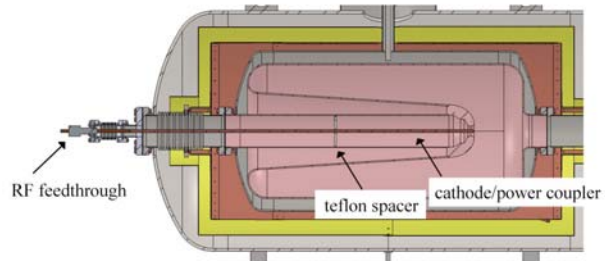

Figure 4: Testing setup for first cryogenic RF test.

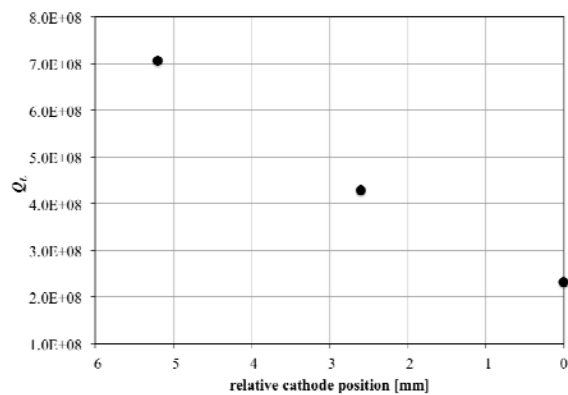

Figure 5: Loaded Q vs. cathode position.

RF power scans were performed at two extreme values of loaded Q . The observed multipacting barriers proved to be easily conditioned away. As shown in Figure 6, cavity Q of as high as 10^9 was observed at fields corresponding to the gap voltage up to about 0.5 MV. The limit was imposed by the radiation safety requirements of 2 mrem/hr, as there was no dedicated radiation shielding around the cryomodule. The cavity Q is reduced when the cathode/coupler is inserted further into the high field region as shown in the lower curve. The reduction is consistent with the one expected from computer simulations. Further, very little degradation of the cavity Q at ~ 0.5 MV due to field emission was observed and no cavity quenches at high field were seen. Conditioning of field emission sites could potentially eliminate all cavity Q degradation at these field levels, giving good confidence that this gun can perform in the desired range 1.5 to 2.5 MV. The static heat leak, estimated from the helium boil-off, is less than 7 W

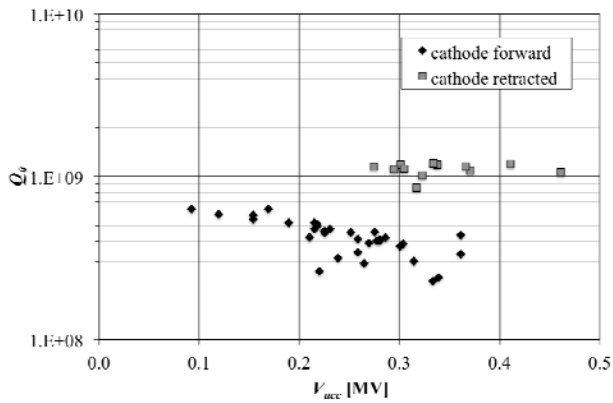

Figure 6: Cavity Q vs. gap voltage with the cathode/coupler in two different positions.

GUN MODIFICATION

The near future experiments with the 112 MHz SRF gun will concentrate on studies of multi-alkali and diamond-amplified photocathodes. Further down the line it will be used to produce high-charge electron bunches for the coherent electron cooling proof-of-principle (CeC PoP) experiment at BNL [5]. To be used in the aforementioned experiments, the gun will undergo the following modifications:

- The low-carbon-steel vacuum vessel will be replaced with a stainless steel one to meet ASME Pressure Code requirements.
- The vacuum vessel will have flanges on both ends to allow easy access to inside of the cryostat.
- A second magnetic shield will be added.
- Cryogenic stack will be modified to interface with the BNL refrigeration system.
- Stainless steel bellows and beam tubes inside the cryostat will be copper plated to reduce RF losses.
- Cathode stalks, inserts and a load lock system will be designed and fabricated for multi-alkali and diamond-amplified photocathodes.
- As the CeC PoP experiment requires cavity frequency tuning, the new FPC of a coaxial beam pipe type will be also used for tuning.

The FPC and the cathode stalks will be similar to those used in the NPS prototype 500 MHz SRF gun [6]. The new RF power coupler / frequency tuner and the cathode stalk assemblies for photocathodes are being designed [7], Figure 7. The frequency tuner will have range of at least 100 kHz. The FPC will provide adjustability of the external quality factor from 3×10^7 to 1.2×10^8 to cover different CeC PoP operating conditions with the gap voltage from 1 MV to 2 MV and bunch charge from 1 nC to 3 nC at the bunch repulsion frequency of 78 kHz.

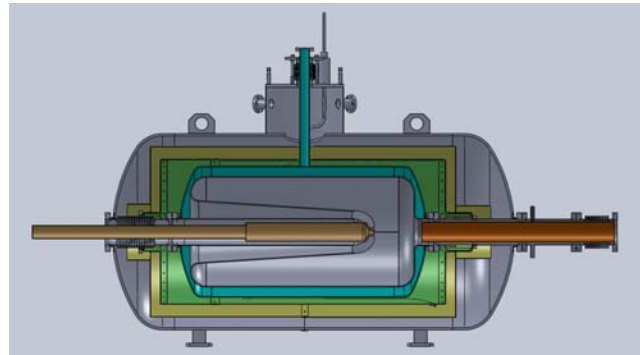

Figure 7: SRF gun cryomodule with the new cathode stalk and FPC.

SUMMARY

We have successfully designed and cold-tested the 112 MHz SRF gun based on a quarter-wave resonator. The gun cryomodule demonstrated good cryogenic performance. RF losses are consistent with simulations. The observed multipacting barriers were easy to process. There was no cavity quenches and the achieved gap voltage of ~ 0.5 MV was limited only by the radiation safety requirements.

We plan to use this SRF gun to study different photocathodes and provide electrons for the coherent electron cooling proof-of-principle experiment at BNL.

REFERENCES

- [1] A. Fedotov, et al., "Feasibility of Electron Cooling for Low-Energy RHIC Operation," BNL Collider-Accelerator AP Note C-A/AP/307(April 2008).
- [2] A. Fedotov, et al., "Electron Cooling for Low-Energy RHIC Program," *Proceedings of COOL09*, Lanzhou, China, MOM2MCIO01, p. 11 (2009).
- [3] S. Belomestnykh, et al., "Design and First Cold Test of BNL Superconducting 112 MHz QWR for Electron Gun Applications," *Proceedings of PAC'2011*, TUP051 (2011).
- [4] K. Halbach and R.F. Holsinger, "SUPERFISH – A Computer Program for Evaluation of Rf Cavities with Cylindrical Symmetry," *Particle Accelerators* **7** (1976) 213-222.
- [5] G. Wang, et al., "Proof-of-Principle Experiment for FEL-based Coherent Electron Cooling," *Proceedings of PAC'2011*, THOBN3 (2011).
- [6] S. P. Niles, et al., "NPS Prototype Superconducting 500 MHz Quarter-Wave Gun Update," *Proceedings of FEL2010*, WEPB28 (2010).
- [7] T. Xin, et al., "Design of the Fundamental Power Coupler and Photocathode Inserts for the 112 MHz Superconducting Electron Gun," this conference, MOPO014.