



# Molten Salt Power Tower Cost Model for the System Advisor Model (SAM)

Craig S. Turchi and Garvin A. Heath  
*National Renewable Energy Laboratory*



NREL is a national laboratory of the U.S. Department of Energy, Office of Energy Efficiency & Renewable Energy, operated by the Alliance for Sustainable Energy, LLC.

**Technical Report**  
NREL/TP-5500-57625  
February 2013

Contract No. DE-AC36-08GO28308

# Molten Salt Power Tower Cost Model for the System Advisor Model (SAM)

Craig S. Turchi and Garvin A. Heath  
*National Renewable Energy Laboratory*

Prepared under Task No. SM12.6030

**NREL is a national laboratory of the U.S. Department of Energy, Office of Energy Efficiency & Renewable Energy, operated by the Alliance for Sustainable Energy, LLC.**

## NOTICE

This report was prepared as an account of work sponsored by an agency of the United States government. Neither the United States government nor any agency thereof, nor any of their employees, makes any warranty, express or implied, or assumes any legal liability or responsibility for the accuracy, completeness, or usefulness of any information, apparatus, product, or process disclosed, or represents that its use would not infringe privately owned rights. Reference herein to any specific commercial product, process, or service by trade name, trademark, manufacturer, or otherwise does not necessarily constitute or imply its endorsement, recommendation, or favoring by the United States government or any agency thereof. The views and opinions of authors expressed herein do not necessarily state or reflect those of the United States government or any agency thereof.

Available electronically at <http://www.osti.gov/bridge>

Available for a processing fee to U.S. Department of Energy and its contractors, in paper, from:

U.S. Department of Energy  
Office of Scientific and Technical Information  
P.O. Box 62  
Oak Ridge, TN 37831-0062  
phone: 865.576.8401  
fax: 865.576.5728  
email: <mailto:reports@adonis.osti.gov>

Available for sale to the public, in paper, from:

U.S. Department of Commerce  
National Technical Information Service  
5285 Port Royal Road  
Springfield, VA 22161  
phone: 800.553.6847  
fax: 703.605.6900  
email: [orders@ntis.fedworld.gov](mailto:orders@ntis.fedworld.gov)  
online ordering: <http://www.ntis.gov/help/ordermethods.aspx>

Cover Photos: (left to right) PIX 16416, PIX 17423, PIX 16560, PIX 17613, PIX 17436, PIX 17721, PIX 19807



Printed on paper containing at least 50% wastepaper, including 10% post consumer waste.

# Table of Contents

<b>Summary</b> .....	<b>1</b>
<b>Background and Motivation</b> .....	<b>1</b>
<b>Objectives</b> .....	<b>2</b>
<b>Approach</b> .....	<b>2</b>
Direct Cost Categories.....	4
Indirect Costs.....	5
Impact of Labor Cost.....	6
Power Tower Cost Model Spreadsheet and Reference Plant .....	7
<b>Conclusions</b> .....	<b>9</b>
<b>References</b> .....	<b>10</b>
<b>Appendix A – Power Tower System Subcategories for SAM Model</b> .....	<b>11</b>
<b>Appendix B – SAM-2012-11-30 / Excel Exchange Variables</b> .....	<b>13</b>
<b>Appendix C – Financial Assumptions Used for SAM Power Tower Reference Plants</b> .....	<b>14</b>
<b>Appendix D – WorleyParsons Subcontract Report: Power Tower Plant Cost and Material Input to Life Cycle Assessment (LCA)</b> .....	<b>15</b>

## Summary

This report describes a component-based cost model developed for molten-salt power tower solar power plants. The cost model was developed by the National Renewable Energy Laboratory (NREL), using data from several prior studies, including a contracted analysis from WorleyParsons Group, which is included herein as an Appendix. The WorleyParsons analysis also estimated material composition and mass for the plant to facilitate a life cycle analysis of the molten salt power tower technology. Details of the life cycle assessment have been published elsewhere [1].

The cost model provides a reference plant that interfaces with NREL's System Advisor Model or SAM. The reference plant assumes a nominal 100-MW<sub>e</sub> (net) power tower running with a nitrate salt heat transfer fluid (HTF). Thermal energy storage is provided by direct storage of the HTF in a 2-tank system. The design assumes dry-cooling. The model includes a spreadsheet that interfaces with SAM via the Excel Exchange option in SAM. The spreadsheet allows users to estimate the costs of different-size plants and to take into account changes in commodity prices. This report and the accompanying Excel spreadsheet can be downloaded at <https://sam.nrel.gov/cost>.

## Background and Motivation

The Solar Advisor Model was developed to assist solar stakeholders in assessing the performance and cost of photovoltaic (PV) and concentrating solar power (CSP) electricity generation systems. The program has since expanded to cover additional renewable energy technologies and been renamed the System Advisor Model (SAM). SAM incorporates modules that estimate the performance of different PV and CSP systems based on design parameters and climate files that include solar and weather data for the selected location. As of this report, the current SAM version is 2012-11-30, available at <https://sam.nrel.gov/>. SAM also includes algorithms to estimate the levelized cost of electricity (LCOE) based on a variety of selectable financial and incentive assumptions. Essential inputs of the LCOE calculations include the estimated installed cost and operating cost of the technology.

In 2010 NREL released a cost model for parabolic trough systems that was designed to interface with SAM [2]. This was followed in 2011 with a life cycle assessment for a parabolic trough power plant with 6 hours of thermal energy storage [3]. These reports, and the associated SAM case, provided a performance, cost, and materials life cycle assessment for the most common CSP technology in the marketplace.

System performance projections suggest that power tower, aka central receiver, power plants can produce power for lower cost than existing oil-HTF parabolic trough systems [4]. Consequently there is growing commercial interest in power tower systems. Molten salt power towers were demonstrated in the U.S. by the 10 MW Solar Two project in the late 1990s [5]. The HTF at Solar Two, and for salt towers since, is a 60 wt%, sodium nitrate, 40 wt% potassium nitrate blend commonly known as "solar salt." Molten salt towers incorporate direct storage of the HTF in hot- and cold-salt storage tanks to provide thermal energy storage and decouple solar energy collection from electricity production. The design powers a Rankine steam thermal cycle at temperatures and pressures consistent with that used in coal-fired power systems, allowing for use of well-developed thermodynamic power cycles running at gross conversion efficiencies of

circa 42%. The current state-of-the-art is embodied in the 19.9-MW<sub>e</sub> Gemasolar Tower that was commissioned in Spain in 2011 [6]. In the US, the 110 MW<sub>e</sub> Crescent Dunes Solar Project is under construction near Tonopah, Nevada [7].

This report summarizes the recent size and cost studies, funded by the U.S. Department of Energy (DOE), for molten salt power towers. SAM is the DOE's primary tool for CSP performance and cost analysis. The paper includes a SAM-compatible cost model that provides component-level costs and scaling parameters to adjust plant size.

## Objectives

The objectives of developing the power tower cost model spreadsheet include:

- Creating a model that allows SAM users to look at the cost impact of individual components of a typical power tower plant. For example, mirror manufacturers wish to know how much of the total plant cost is due to the cost of the reflector materials.
- Providing a framework to account for fluctuations in commodity prices over time to keep the cost model current by incorporating appropriate cost indices for the different cost components.
- Providing a framework to adjust cost data for changing scale in the various system components.
- Providing a framework to adjust cost data for different labor rates associated with different project sites.

The result of these objectives is a spreadsheet model that allows users to update costs for changes in technology or markets. The spreadsheet is designed to interface with the Molten Salt Power Tower Model in SAM-2012-11-30. Users are encouraged to customize the spreadsheet model for their individual purpose.

## Approach

In March 2010, the DOE and Sandia National Laboratories hosted a Power Tower Technology Workshop that included participation of industry, the national laboratories, and DOE. At the workshop, areas of discussion included the current status of power tower technology, technology improvement opportunities, and cost-reduction goals for power tower systems and subsystems. The findings of this exercise were later published as the Power Tower Technology Roadmap and Cost Reduction Plan [8], hereafter referred to as the "Roadmap." The Roadmap provided a system-level assessment of the costs for a current molten-salt power tower, with the major systems defined as shown in Figure 1.

Two other recent studies provided useful size and cost information for the SAM model. In 2010, a contract report by Abengoa Solar documented the estimated cost for power towers using supercritical coolants [10]. This report included size and cost information for the current state-of-the-art molten salt power tower. Elements of this report were used in the current cost model. The second study was a tower cost and material analysis performed by WorleyParsons Group Inc. (Denver, CO).

In 2010 NREL published a cost study on parabolic trough plants that was undertaken via contract with WorleyParsons. WorleyParsons was selected as an engineering firm with comprehensive services related to all aspects of project development, environmental impact assessment, detailed design, procurement, construction, and operations & maintenance of renewable energy power plants, exemplified by their history of engineering design and cost support for multiple renewable energy and conventional power projects in the United States and abroad. NREL provided WorleyParsons with nominal design specifications for the reference plant, and the contractor completed a conceptual design and cost assessment of a parabolic trough plant with wet cooling and optional dry cooling. WorleyParsons also provided the material composition and mass data necessary for NREL's life cycle analysis of the parabolic trough design.

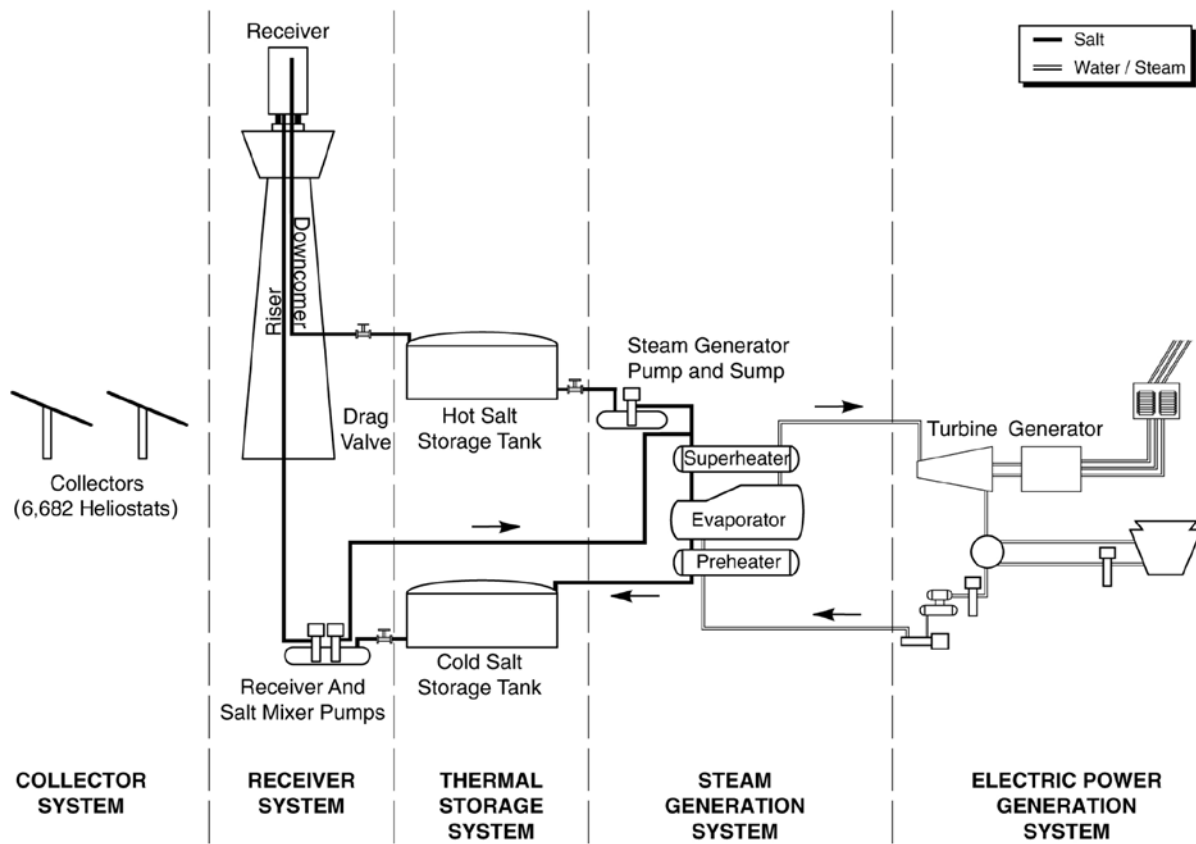

**Figure 1. Schematic of a molten salt power tower showing major subsystems [8,9]. Heliostat count is based on WorleyParsons study case.**

In 2011, WorleyParsons was contracted to perform a similar analysis for the molten salt power tower design. Using the same contractor ensured that the two CSP studies would be consistent in their structure and methodology. Similar to prior parabolic trough case, installed cost data for components of the molten salt power tower design were provided by WorleyParsons under their contract. Because the previously mentioned sources provided cost information, the primary objective of the WorleyParsons study was to develop the mass and material estimates necessary for a life cycle assessment of the molten salt power tower design. WorleyParsons also estimated the cost of many of the power tower plant components. One exception was the solar field, which was excluded from the WorleyParsons scope of work. The WorleyParsons analysis used the



same system definitions (Figure 1) to be consistent with the prior work. These systems also represent the major cost categories in the SAM molten salt power tower model.

## Direct Cost Categories

Each of the systems shown in Figure 1 was divided into a number of components for the SAM power tower cost model and costs for system components were estimated in the following manner:

- **Collector System.** The solar, or heliostat, field was subdivided into the following components: mirrors; drives; pedestal, support and foundation; controls and wired connections; field wiring and foundations labor; installation and checkout. The cost breakout for each component followed the estimate provided in the Roadmap for the 148m<sup>2</sup> ATS heliostat with a 5000/unit per year production level. The cost element for “manufacturing facilities and profit” in the Roadmap was proportioned across the cost categories. Solar field costs scale linearly with total solar field reflector area. Unlike the other systems, the design and cost of the solar field system was excluded from WorleyParsons’ analysis and was based on data from [8,10,11].
- **Tower/Receiver System.** The tower/receiver system was subdivided into a tower category including the tower and riser/downcomer piping & insulation and a receiver category including the receiver, horizontal piping & insulation, cold salt pumps, controls & heat tracing. This division was necessary because SAM calculates tower and receiver costs separately. SAM and the cost spreadsheet scale tower components by tower height. SAM scales all receiver components with receiver area, however, the cost model spreadsheet scales only the receiver by receiver area. Other receiver components are scaled by receiver thermal power.
- **Thermal Storage System.** The thermal storage system was subdivided into six component costs: hot tank, cold tank, storage media, piping & insulation, foundations, instruments & controls. TES costs are scaled by TES capacity in MWh-t.
- **Steam Generation System.** SAM’s cost page includes a “Balance of Plant” category that allows users to break out plant components from the major categories for analysis purposes. Following the convention of the Roadmap, the costs for the steam generation system are segregated from the power generation system and listed under the balance of plant category. This is convenient for comparing molten salt and direct steam power towers. The steam generation system includes: evaporator and preheater circulation pumps; hot salt circulation and transfer pumps; heat exchangers for reheat, evaporation, and preheating (economizer); steam drum; as well as the associated piping, valves, insulation, electrical, controls, and foundations associated with that equipment.
- **Power Generation System.** The power block costs were estimated using data from the WorleyParsons’ study, adjusted for labor rates costs in southern California, along with information from [10]. The power block system is divided into 17 component costs as shown in Appendix A. Power block costs scale with gross turbine capacity.
- **Site Preparation.** SAM includes an explicit cost category for site preparation. This category includes clearing and grading land, storm water control, roads and fences, blowdown evaporation pond, and water supply infrastructure. The tower model bases site



preparation costs on those from the trough plants in [2]. Costs for clearing and grading were reduced by 90% under the assumption that the heliostat field would not be graded. Site preparation costs scale with plant land area.

SAM applies an overall contingency on all direct costs. Contingency addresses unforeseen costs within the project and it is assumed that all contingency will be consumed during the course of project construction.

## Indirect Costs

Indirect costs in SAM are designed to capture non-hardware project costs such as permitting, land, legal fees, geotechnical and environmental surveys, taxes, interest during construction, and the owner's engineering and project management activities. Some of these categories are listed explicitly, while many are simply lumped into the *EPC and Owner Cost* category. SAM's *EPC & Owner Cost* percentages are based on a review of cost estimates from nine utility-scale projects under the federal loan guarantee program. Land cost is estimated at \$10,000 per acre. Sales Tax is approximately equal to the national average – the value has been standardized across SAM technologies, and SAM assumes sales tax is applied to 80% of the total direct costs. Most CSP plants take more than one year for construction. SAM's default financing costs assume a 24-month construction period with a 5% loan for the full overnight construction costs. This translates into approximately an additional 6% cost to the project. Combined, the multiplier for indirect costs (EPC & Owners Costs, Land, Sales Tax, and Financing during construction) within SAM is approximately 25.8%. The cost input summaries for the Roadmap, the WorleyParsons' study and SAM are shown in Table 1 for comparison.

**Table 1. Cost summaries from Tower Roadmap, the WorleyParsons analysis, and the current SAM default parameters for a molten salt power tower. The SAM default values aggregate information from several sources.**

Direct Cost (DC) Category	Units	Tower Roadmap [8]	WorleyParsons Group (Appendix)	SAM 2012-11-30 Default Values
Assumed location	-	Daggett, CA	Tucson, AZ	Daggett, CA
Site Improvements	\$/m <sup>2</sup>	-	20	15
Solar Field	\$/m <sup>2</sup>	200	n/a	180
Balance of Plant (Steam Generation System)	\$/kW	350	365	350
Power Block (dry cooled)	\$/kW	1000	1000	1200
Fossil Backup	\$/kW	-	-	-
Storage	\$/kWh-t	30	35.5	27
Tower / Receiver	\$/kW-t	200	142‡	173‡
Contingency	% of DC	Included in above	9.5	7
<b>Indirect Cost Category</b>				
EPC & Owner Costs	% of DC	25	-	11
Land	\$/acre	-	-	10,000
Sales Tax Rate	applied to 80% of DC	7.75% (CA)	-	5.0% (US avg)
Financing during Construction	% of overnight costs	-	-	6.0
Combined Indirects	% of DC	31.2%	-	25.8%
<b>O&amp;M Cost Category</b>				
Fixed Annual Cost	\$/yr	0	-	0
Fixed Cost by Capacity	\$/kW-yr	70	-	65
Variable Cost by Gen.	\$/MWh	3	-	4

‡ SAM estimates tower and receiver costs separately. This value is calculated by summing the total tower and receiver cost (excluding contingency) and dividing by the rated receiver thermal power.

## Impact of Labor Cost

The SAM default case follows the Roadmap selection of Daggett, CA, as the reference plant location. Accordingly the spreadsheet model assumes southern California labor rates. Labor rates can be changed to other locations by adjusting the Labor Cost Factor given as User Variable 2 in SAM. Labor rates and categories are taken from the U.S. Bureau of Labor under NAICS 221100, Electric Power Generation, Transmission and Distribution, May 2011 [12]. Because the power tower reference plant assumes southern California labor rates, the Labor Cost Factor for California is normalized to 1.0 (in contrast to the parabolic trough model where Phoenix labor is normalized to 1.0). For the tower model the corresponding national average is 0.63 and the value for Tucson, AZ is 0.47. (Private industry, mean hourly wage, union labor, Riverside, CA versus US national average and nonunion Tucson, AZ).

Users are encouraged to supply their own labor rate correction factor via User Variable 2 in SAM. The assumed labor rate has a significant effect on installed system cost and operating costs.

## Power Tower Cost Model Spreadsheet and Reference Plant

The spreadsheet contains cost information for two plants: a “reference plant” and a “project plant.” The reference plant matches the default molten salt power tower in SAM 2012-11-30. The reference plant (highlighted in yellow) is defined as a 115-MW<sub>e</sub> gross power tower with 10 hours of thermal energy storage located in southern California. The solar multiple was set to 2.4, and SAM was used to calculate the associated solar field size. The TMY2 climate file for Daggett, CA was employed. Costs for the reference plant come from a variety of sources as described above. In some cases the specific costs listed are an aggregate from multiple sources. This process is used to incorporate opinions of multiple developers and as a mean of updating technology costs based on advances since the referenced cost study dates.

The spreadsheet cost model is designed to interface with SAM, but it may be used directly without calling SAM. The project plant provided in the spreadsheet (highlighted in orange) represents the user’s specific scenario. Data for the project plant can be entered by the user into the orange cells on the *SAM Exchange* worksheet. If linked to SAM, these cells are populated automatically during SAM’s *Excel Exchange* process. In either event, the spreadsheet calculates the project plant costs by scaling based on the size of project plant components compared to those of the reference plant. As supplied, the project plant is set to match the reference plant case.

The spreadsheet includes cost indices to escalate component and labor costs for inflation and market factors. Cost indices in the spreadsheet model are based on the Chemical Engineering Plant Cost Index published monthly in *Chemical Engineering Magazine* and available online at <http://www.che.com/>. Additional cost indices are taken from the U.S. Bureau of Labor’s Producer Price Index (PPI), which can be tracked on line at <http://www.bls.gov/ppi/>. The spreadsheet includes a PPI index for synthetic ammonia to represent the nitrate salt storage media in trough plants. This public index tracks the nitrogen fertilizer market; however, vendor data suggest it may not be an accurate surrogate for solar salt prices. An estimate of historic solar salt prices is also included. Salt price has a large impact on overall storage costs, and users are encouraged to check with vendors for these prices. Users may also customize the spreadsheet by choosing alternative cost indices. Within the spreadsheet, a specific cost index is selected by changing the *Matl cost esc Factor* or *Labor cost esc Factor*.

The cost model spreadsheet interfaces with SAM through the Excel Exchange linkage. (Note to Mac users: the Excel Exchange option does not function on Mac computers.) Excel Exchange allows users to connect any input variable in SAM to a cell or range of cells in a Microsoft Excel workbook. This feature allows users to use external spreadsheet-based cost and performance models to generate values for SAM input variables. User-defined input variables can also share values with external workbooks. The cost model uses four user variables. Exchange variables are listed in Appendix B. To access Excel data exchange in SAM, first click Configure Simulations to view the Configure Simulation page:

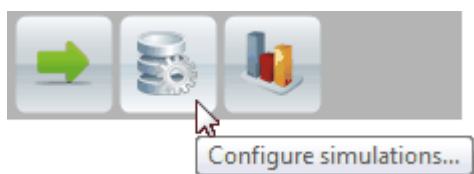

Then click Excel Exchange to display the Excel data exchange options:

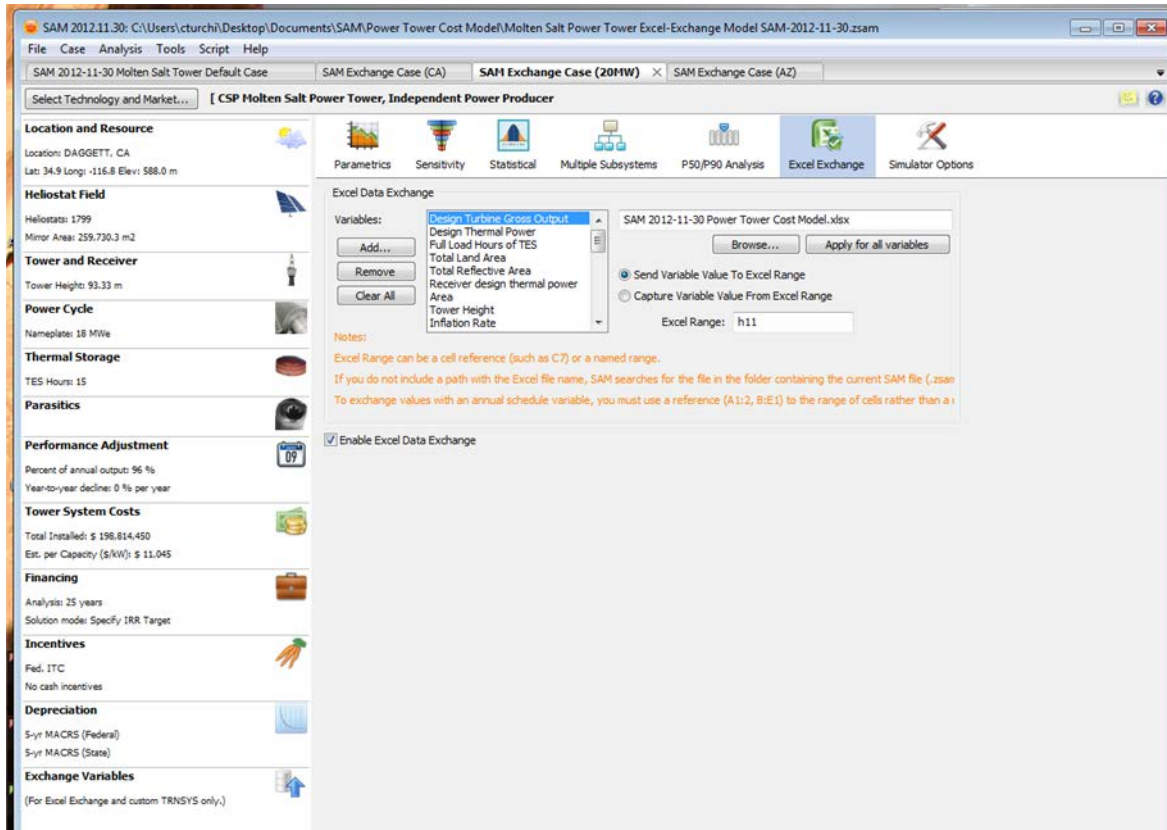
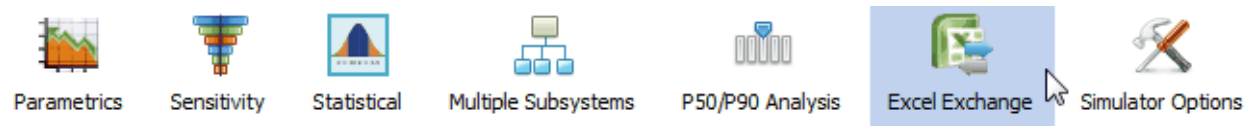

**Figure 2. Excel Exchange page in SAM 2012-11-30.**

The SAM Excel Exchange variable entry page is shown in Figure 2; more information on customizing SAM with Excel Exchange can be found in the SAM help files. When retrieving data from Excel via the SAM Excel Exchange, the cells in Excel must not have \$ or % formatting. Such formatting will cause an error message in SAM. Also, note that after the exchange process, the spreadsheet does not retain the values read in from SAM; in contrast, the SAM case does retain the values pulled from the spreadsheet.

Examples of the use of the cost spreadsheet with SAM are shown in Table 2 below. The four columns list results for the SAM default molten salt power tower in Daggett, CA, the same default case supplied with the cost spreadsheet, the default tower design moved to Arizona, and a smaller power tower located in Daggett, CA. The impact of lower labor rates can be seen for the Arizona location. The smaller tower case highlights the advantage of scale with the CSP technology. A smaller plant incurs greater installed and operating costs per capacity that lead to a larger LCOE.

**Table 2. SAM modeling results using the spreadsheet cost model.**

Design Parameters	SAM 2012-11-30 Default Case	SAM 2012-11-30 Spreadsheet Model	Arizona Labor Rates Case	Smaller Tower Case
Power block gross rating (MW <sub>e</sub> )	115	115	115	20
Thermal storage at design point (hours)	10	10	10	15
Solar multiple	2.4	2.4	2.4	2.8
Design conditions dry-bulb temperature (°C)	42	42	42	42
Location (weatherfile)	Daggett, CA	Daggett, CA	Tucson, AZ	Daggett, CA
<b>Size Parameters</b>				
Tower height (m)	203	203	203	93
Receiver design thermal power (MW <sub>t</sub> )	670	670	670	136
Solar Field area (m <sup>2</sup> )	1,289,000	1,289,000	1,289,000	260,000
Thermal storage salt volume (m <sup>3</sup> )	13,000	13,000	13,000	3,390
<b>Performance Outputs from SAM</b>				
Net Capacity (MW <sub>e</sub> ), annual average	105	105	105	18
Annual net electricity generation (MWh)	539,700	539,700	519,400	109,200
Capacity factor (based on MW <sub>e</sub> net)	58.9%	58.9%	56.7%	69.2%
Estimated land area (acre)	1,953	1,953	1,953	447
<b>Cost Outputs from SAM</b>				
Total Overnight Installed Costs (\$/kW <sub>e, net</sub> )	7,490	7,500	6,870	11,000
Total Project Installed Costs (\$/kW <sub>e, net</sub> )	7,910	7,920	7,250	11,700
LCOE (¢/kWh), real with 30% ITC	11.8	11.9	11.0	17.1
LCOE (¢/kWh), real with 10% ITC	14.9	15.0	14.0	20.6

## Conclusions

A component-based cost model has been developed for SAM's molten-salt power tower model. The cost model spreadsheet interfaces with SAM through the Excel Exchange function. Costs are based on a nominal 100-MW<sub>e</sub> (net) reference plant running with a nitrate salt heat transfer fluid (HTF). Thermal energy storage is provided by direct storage of the HTF in a 2-tank system, and the design assumes dry cooling. The spreadsheet allows users to estimate the cost of different-size plants and to take into account changes in commodity prices, and labor rates for different project locations. This report and the accompanying Excel spreadsheet can be downloaded at <https://sam.nrel.gov/cost>.

## References

1. Whitaker, M.B., G.A. Heath, J.J. Burkhardt, and C.S. Turchi, "Life Cycle Assessment of a Power Tower Concentrating Solar Plant and the Impacts of Key Design Alternatives," submitted to *Environ. Sci. Technol.* 2013.
2. Turchi, C.S., "Parabolic Trough Reference Plant for Cost Modeling with the Solar Advisor Model (SAM)," NREL/TP-550-47605, July 2010.
3. Burkhardt, J.J., III; G.A. Heath, and C.S. Turchi, "Life Cycle Assessment of a Parabolic Trough Concentrating Solar Power Plant and the Impacts of Key Design Alternatives," *Environmental Science & Technology*, Vol.45, Iss.6; p.2457-2464 (2011).
4. Turchi, C.S., M. Mehos, C.K. Ho and G.J. Kolb, "Current and Future Costs for Parabolic Trough and Power Tower Systems in the US Market," NREL/CP-5500-49303, presented at SolarPACES 2010, Perpignan, France, September 21-24, 2010.
5. Pacheco, J.E., "Final Test and Evaluation Results from the Solar Two Project," SAND2002-0120, 2002.
6. Burgaleta, J.I, S. Arias, and D. Ramirez, "Gemastar, the First Tower Thermosolar Commercial Plant with Molten Salt Storage, SolarPACES 2011, Granada, Spain, September 20-23, 2011.
7. <http://www.solarreserve.com/what-we-do/csp-projects/crescent-dunes/>
8. Kolb, G.J., C.K. Ho, T.R. Mancini, and J.A. Gary, "Power Tower Technology Roadmap and Cost Reduction Plan," SAND2011-2419, Sandia National Laboratories, Albuquerque, NM, April 2011.
9. Reilly, H.E, and G.J. Kolb, "An Evaluation of Molten-Salt Power Towers Including Results of the Solar Two Project," SAND2001-6674, Sandia National Laboratories, November 2001.
10. Kelly, B., "Advanced Thermal Storage for Central Receivers with Supercritical Coolants," DOE Contract Report under Grant DE-FG36-08GO18149, June 2010.
11. Kolb, G. J., S. A. Jones, M. W. Donnelly, D. Gorman, R. Thomas, R. Davenport, and R. Lumia, "Heliostat Cost Reduction Study," SAND2007-3293, Sandia National Laboratories, Albuquerque, NM, June 2007.
12. National Compensation Survey, U.S. Department of Labor, May 2011, accessed December 2012 from <http://www.bls.gov/ncs/summary.htm>
13. Pacific Gas & Electric Company, "Solar Central Receiver Technology Advancement for Electric Utility Applications," Phase 1 Topical Report, Report No. 007.2-88.2, San Francisco, CA, September 1988; Arizona Public Service Company, "Utility Solar Central Receiver Study," Report No. DOE/AL/38741-1, November 1988; Alternate Utility Team, "Utility Solar Central Receiver Study," Report No. DOE/AL/38741-2, September 1988.
14. Kistler, B.L., "A User's Manual for DELSOL3: A Computer Code for Calculating the Optical Performance and Optimal System Design for Solar Thermal Central Receiver Plants," SAND86-8018, Sandia National Laboratories, November 1986.
15. Gilman, P., 2010. Solar Advisor Model User Manual, latest ed. National Renewable Energy Laboratory, Golden, Colorado. See also URL [www.nrel.gov/analysis/sam/publications](http://www.nrel.gov/analysis/sam/publications).

# Appendix A – Power Tower System Subcategories for SAM Model

## **DIRECT CAPITAL COSTS**

Site - Site Preparation  
Site - Clearing & Grubbing  
Site - Grading, Drainage, Remediation, Retention, & Detention  
Site - Evaporation Pond  
Site - Roads, Parking, Fencing  
Site - Water Supply Infrastructure

Heliostat Field - Mirrors  
Heliostat Field - Drives  
Heliostat Field - Pedestal, Mirror Support, Foundation  
Heliostat Field - Controls and Wired Connections  
Heliostat Field - Field Wiring & Foundations Labor  
Heliostat Field - Installation & Checkout

Tower - Tower  
Tower - Riser and Downcomer Piping & Insulation

Receiver - Receiver  
Receiver - Horizontal Piping & Insulation  
Receiver - Cold Salt Pump(s)  
Receiver - Controls, Instruments, Heat Trace  
Receiver - Spare Parts

TES - Cold Tank(s)  
TES - Hot Tank(s)  
TES - Media  
TES - Piping, Insulation, Valves, & Fittings  
TES - Foundations & Support Structures  
TES - Instrumentation & Controls

Fossil Backup

## **SAM BOP Defined as Steam Generation System**

BOP - Steam Generation Heat Exchangers and Equipment  
BOP - Hot Salt Pump(s)  
BOP - Steam Piping, Insulation, Valves, & Fittings  
BOP - Electrical, Instrumentation, and Controls System  
BOP - Foundations & Support Structures

Power Plant - Steam Turbine Generator Island  
Power Plant - Blowdown System  
Power Plant - Cooling Systems



Power Plant - Condensate System  
Power Plant - Feedwater System  
Power Plant - Auxiliary Cooling Water System  
Power Plant - Steam Piping, Insulation, Valves, & Fittings  
Power Plant - Fuel Gas Handling & Metering System  
Power Plant - Water Treatment System  
Power Plant - Power Distribution Systems  
Power Plant - Back-up Power Systems  
Power Plant - Instruments and Controls System  
Power Plant - Fire Protection System  
Power Plant - Foundations & Support Structures  
Power Plant - Buildings  
Power Plant - BOP Mechanical Systems  
Power Plant - BOP Electrical Systems

## Appendix B – SAM-2012-11-30 / Excel Exchange Variables

Variables out from SAM to Excel:	Excel Cell	Comments
Design Turbine Gross Output	h11	
Design Thermal Power	h12	Power block design thermal power
Full Load Hours of TES	h13	
Total Land Area	h14	
Total Reflective Area	h15	Total solar field area
Receiver Design Thermal Power	h16	
Area	h17	Receiver area, shown on SAM Costs page
Tower Height	h18	
Inflation Rate	h19	
Sales Tax	h20	
User Variable 1	h21	Analysis year
User Variable 2	h22	Labor_cost_factor
Variables in to SAM from Excel:		
Fixed Tower Cost	e11	Cost Factor for SAM's scaling equation
Receiver Reference Cost	e12	Cost Factor for SAM's scaling equation
Receiver Reference Area	e13	Cost Factor for SAM's scaling equation
Receiver Cost Scaling Exponent	e14	Cost Factor for SAM's scaling equation
Site Improvement Cost per m2	i26	
Heliostat Field Cost per m2	i27	
Storage Cost per kWht	i30	
Fossil Backup Cost per kWe	i31	
Balance of Plant Cost per kWe	i32	
Power Block Cost per kWe	i33	
Contingency	i34	
EPC Costs % Direct	i37	Percent of direct costs
Land Costs acre	i38	\$ per acre
Sales Tax Percentage of Direct Costs	i39	
Fixed Annual Cost	i43	
Fixed Cost by Capacity	i44	
User Variable 5	i45	Annual O&M variable cost, used to calc Variable Cost by Generation
Fossil Fuel Cost	i46	
User Variable 6	i47	Estimated O&M labor force

# Appendix C – Financial Assumptions Used for SAM Power Tower Reference Plants

SAM 2012.11.30: C:\Users\cturchi\Desktop\Documents\SAM\Power Tower Cost Model\Molten Salt Power Tower Excel-Exchange Model SAM-2012-11-30.zsam

File Case Analysis Tools Script Help

SAM 2012-11-30 Molten Salt Tower Default Case x SAM Exchange Case

Select Technology and Market... [ CSP Molten Salt Power Tower, Independent Power Producer

**Location and Resource**

Location: DAGGETT, CA  
Lat: 34.9 Long: -116.8 Elev: 588.0 m

**Heliostat Field**

Heliostats: 8929  
Mirror Area: 1,289,122.6 m<sup>2</sup>

**Tower and Receiver**

Tower Height: 203.33 m

**Power Cycle**

Nameplate: 100 MWe

**Thermal Storage**

TES Hours: 10

**Parasitics**

**Performance Adjustment**

Percent of annual output: 96 %  
Year-to-year decline: 0 % per year

**Tower System Costs**

Total Installed: \$ 783,667,434  
Est. per Capacity (\$/kW): \$ 7,833

**Financing**

Analysis: 25 years  
Solution mode: Specify IRR Target

**Incentives**

Fed. ITC  
No cash incentives

**Depreciation**

5-yr MACRS (Federal)  
5-yr MACRS (State)

**Exchange Variables**

(For Excel Exchange and custom TRNSYS only.)

**Solution Mode**

Specify IRR Target Choose Specify IRR Target when you know the IRR and want SAM to calculate a PPA price.

Specify PPA Price Choose Specify PPA Price when you know the PPA (bid) price and want SAM to calculate the IRR.

You can specify an optional annual power price escalation rate and, for analyses involving time-of-delivery pricing, optional hourly payment allocation factors. See Help for details.

**Specify IRR Target**

Minimum Required IRR  %

PPA Escalation Rate  %

Constraint: Require a minimum DSCR

Minimum Required DSCR

Constraint: Require a positive cashflow

**Financial Optimization**

Allow SAM to pick debt fraction to minimize LCOE

Allow SAM to pick PPA escalation rate to minimize LCOE

**Specify PPA Price**

PPA Price  \$/kWh

PPA Escalation Rate  %/yr

**Loan Parameters**

Debt Fraction  %

Loan Term  years

Loan Rate  %/year

Installed Cost

Construction Financing Cost

Principal Amount

WACC  %

**Analysis Parameters**

Analysis Period  years

Inflation Rate  %/year

Real Discount Rate  %/year

Nominal Discount Rate  %/year

**Tax and Insurance Rates**

Federal Income Tax Rate  %/year

State Income Tax Rate  %/year

Sales Tax  % of installed cost

Insurance Rate (Annual)  % of installed cost

**Property Tax**

Assessed Percent  % of installed cost

Assessed Value

Annual Dedline  %/year

Property Tax  %/year

**Salvage Value**

End of Analysis Period Value

Net Salvage Value  % of installed cost

**Construction Financing**

Specify the terms of up to five optional short-term construction loans. SAM calculates the total financing cost and adds it to the project's investment cost. The sum of percentages in the Percent of Installed Costs column must equal 100%.

Construction Loans	Percent of Installed Costs	Up-front Fee (% of principal)	Months Prior to Operation	Annual Interest Rate (%)	Principal	Interest	Total Construction Financing Cost
Loan 1	100	1	24	5	\$ 783,667,433.96	\$ 39,183,371.70	\$ 47,020,046.04
Loan 2	0	0	0	0	\$ 0.00	\$ 0.00	\$ 0.00
Loan 3	0	0	0	0	\$ 0.00	\$ 0.00	\$ 0.00
Loan 4	0	0	0	0	\$ 0.00	\$ 0.00	\$ 0.00
Loan 5	0	0	0	0	\$ 0.00	\$ 0.00	\$ 0.00
<b>Totals:</b>	<b>100</b>				<b>\$ 783,667,433.96</b>	<b>\$ 39,183,371.70</b>	<b>\$ 47,020,046.04</b>

**Appendix D – WorleyParsons Subcontract Report:  
Power Tower Plant Cost and Material Input to Life  
Cycle Assessment (LCA)**

# Power Tower Plant Cost and Material Input to Life Cycle Assessment (LCA)

NREL Task 8, Final Report-**PUBLIC**

NREL-8-ME-REP-0002 Rev 2

*Prepared for:*

National Renewable Energy Laboratory (NREL)

*Prepared by:*

**WorleyParsons Group, Inc.**

1687 Cole Blvd, Suite 300

Golden, Colorado 80401 USA

October 08, 2012



## TABLE OF CONTENTS

<b>1.</b>	<b>SUMMARY .....</b>	<b>6</b>
<b>2.</b>	<b>PROJECT DESCRIPTION .....</b>	<b>6</b>
<b>3.</b>	<b>CONCEPTUAL DESIGN .....</b>	<b>6</b>
<b>4.</b>	<b>COST ESTIMATE BASIS.....</b>	<b>7</b>
4.1	Quantity Development .....	7
4.2	Material and Equipment Pricing.....	7
4.3	Construction Labor .....	8
4.4	Clarifications .....	9
4.5	Exclusions.....	10
4.6	Tower Cost & Height Formula .....	11
<b>5.</b>	<b>APPENDICES INFORMATION .....</b>	<b>11</b>



**APPENDICES AND DELIVERABLES**

Appendix A – Conceptual Process Flow Diagram (1 page)

Appendix B – Major Equipment List (2 pages)

Appendix C – Power Tower Plant Capital Cost Summary: Materials and Labor (1 page)

Appendix D – Water Usage (1 page)

Appendix E – Specialized Equipment List (1 page)

Appendix F – Other O & M Energy Requirements (1 page)

Appendix G – References (2 pages)

Appendix H – Variable Tower Height Cost Information (1 page)

Appendix I – Total Mass of Plant Construction Summary (2 pages)

Appendix J – O&M Replacement Mass Summary (1 page)

(Appendix number of pages does not include cover page)

**LIST OF ACRONYMS**

ACC – Air Cooled Condenser  
AISI – American Iron & Steel Institute  
ANSI – American National Standards Institute  
ASME – American Society of Mechanical Engineers  
ASTM – American Society for Testing and Materials  
BLM – Bureau of Land Management  
CMU – Concrete Masonry Units (Load-bearing Cinderblock)  
CS – Carbon Steel  
CSP – Concentrating Solar Power  
EPCM – Engineer, Procurement, Construction Management  
FRP – Fiberglass (or Fiber) Reinforced Plastic  
HTF – Heat Transfer Fluid  
HVAC – Heating, Ventilation, and Air Conditioning  
LCA – Life Cycle Assessment  
MTO – Material Take-off  
MW - Megawatt  
NREL – National Renewable Energy Laboratory  
O & M – Operations & Maintenance  
PDC – Power Distribution Center  
SAM – System Advisor Model  
SGS – Steam Generation System  
SS – Stainless Steel  
STG – Steam Turbine Generator  
TES – Thermal Energy Storage  
TIC – Total Installed Cost  
WSAC – Wet Surface Air Cooler

## **1. SUMMARY**

This report provides the National Renewable Energy Laboratory (NREL) with two objectives. The first objective is a capital cost estimate for the overnight construction of a state-of-the-art solar power tower plant in Tucson, AZ. This estimate provides line item material and labor costs for the individual components of the power plant as well as subsystem costs and a total installed cost (TIC), excluding the heliostat field. The second objective is to provide input to NREL's life cycle assessment (LCA) of this plant which documents the total life cycle emissions, energy payback time and water consumption. This information includes the estimated size, material composition, and mass of system components as well as an operations and maintenance (O & M) schedule. The O&M schedule provides the associated maintenance and consumable material quantities.

This report should be viewed as a high-level assessment with the understanding that site specific information, optimization, and detailed engineering will affect a LCA of an actual plant. This report was prepared for public distribution and the cost and LCA information is therefore provided in summary format. A more detailed confidential report was generated for internal NREL use, which provides cost at the component and subsystem level along with a LCA breakdown by ASTM material specification down to the subsystem level.

## **2. PROJECT DESCRIPTION**

This project is based on the design of a state-of-the-art solar power tower that uses molten nitrate salt as the heat transfer fluid (HTF) and thermal energy storage (TES) media. The plant is designed to generate ~100MWe net (115MWe gross) to the grid at 230kV using 100% dry cooling and having 6 hours of molten salt thermal energy storage (TES). The power tower plant subsystems are comprised of the following:

- Site Improvements
- Heliostat Field (by NREL)
- Tower
- Receiver
- Thermal Energy Storage
- Steam Generation System
- Electric Power Generation System

The subsystem breakout generally follows that described in section 2 of reference [3], listed in Appendix G.

## **3. CONCEPTUAL DESIGN**

The conceptual design of the plant was based largely on SAND2001-2100 "Solar Power Tower Design Basis Document", SAND2001-3674 "An Evaluation of Molten-Salt Power Towers Including Results of the Solar Two Project" and the SAM model sent to WorleyParsons by Craig Turchi on 2/17/2012; "NREL Power Tower for WP Task 8 study SAM-2011-12-02.zsam". Many other references, design tools, standards and specifications were relied upon to conceptually design the plant, some of which are listed in Appendix G.

A heat & mass balance of the major steam, feedwater and steam generation systems was performed to establish design flow, temperature and pressure parameters for the associated equipment and piping. A process flow schematic of the major plant systems is provided in Appendix A – Conceptual Process Flow Diagram. A major equipment list is provided in Appendix B – Major Equipment List.

NREL provided the thermal transfer capacity, panel quantity, diameter, and height of the solar receiver and also the panel tube diameter, wall thickness, and solar absorption length. Tube quantities per panel were calculated from this data and structures were designed to support the panel tubes and headers. An additional structure attached to the top of the tower was designed to support the panels, boom crane, salt inlet vessel, salt outlet vessel, salt overflow vessel, and other auxiliary receiver equipment. The weight of the receiver and equipment, salt piping, heat tracing, insulation, instrumentation, and wiring was calculated to determine the design load on top of and inside of the concrete tower. A concrete tower was designed based on the seismic criteria and typical soils found in the Tucson, AZ area. The tower and receiver include stairs, platforms, and elevators for personnel and equipment.

#### **4. COST ESTIMATE BASIS**

The capital cost estimate is provided in Appendix C - Power Tower Plant Capital Cost Summary: Materials. The estimate is based on an Engineer – Procure – Construction Management (EPCM) approach. Engineering and Design, Construction Management, and Start-up & Commissioning costs are included.

Material Take-off (MTO) and Design Allowances are included in the estimate and are intended to compensate for the degree of engineering that is incomplete. This is not a contingency; rather it is a minor allowance included to cover the nominal quantity growth which inevitably occurs as the design is further developed. Contractor mark-up on bulk materials has been added and reflects the mark-up that contractors will apply to bulk materials provided under their respective contracts.

The estimate excludes escalation. All costs are presented as overnight 2Q2012 dollars.

Project Contingency addresses unforeseen elements of costs within the current defined project scope. It is expected that by the end of the project the entire contingency will be spent on either direct or indirect costs.

##### **4.1 Quantity Development**

Equipment quantities for major equipment components are based on preliminary engineering provided in drawings, flow diagrams, process and instrumentation diagrams (P&ID's), equipment lists, and electric one-line diagrams. Major piping networks, such as the molten salt, steam, feedwater, and condensate systems, were conceptually developed from P&ID's.

Minor balance of plant equipment not included in the project design documents are based on similar plant designs previously developed by WorleyParsons. Examples of minor balance of plant equipment include steam turbine gland steam seal system, condenser air removal system, steam cycle chemical feed system, service air system, steam / water sampling system, and compressed air systems. Bulk material quantities were developed for select major systems based on conceptual routings and sizing where available. Quantities for the balance of plant systems were developed by scaling from a similarly sized plant to meet specific project requirements.

##### **4.2 Material and Equipment Pricing**

Some of the major equipment costs are based on budgetary quotes or pricing from similar project cost data. The remaining equipment costs and bulk material pricing are based on WorleyParsons' cost estimating database, which includes recent pricing for similar materials. Most of the equipment and materials will be transported by truck to the project site.

### **4.3 Construction Labor**

Overall construction labor costs include wage rates, installation hours, labor productivity, labor availability and construction indirect costs.

#### **4.3.1 Wage Rates**

Merit shop wage rates for the Tucson AZ area are based on PAS 2011 Labor Rates for the Construction Industry (Region 9). Rates are valid to 2Q2012.

#### **4.3.2 Installation Hours**

WorleyParsons maintains a database of standard unit installation hours. The database represents standard installation rates for US Gulf Coast Merit Shop. Equipment setting man-hours were developed by evaluating estimated weights, equipment size, and number of components in conjunction with crew sizes and approximated time. Bulk material man-hours are based on standard unit installation rates. The resultant hours are further adjusted for productivity (described below).

#### **4.3.3 Labor Productivity**

The estimate reflects productivity for the Tucson, Arizona area. In evaluating productivity, factors such as jobsite location, type of work (i.e. new construction) and site size are considered. Labor productivity factors (multipliers over US Gulf Coast Merit Shop) have been included to reflect anticipated site specific labor productivity. The productivity for merit shop labor in the Tucson area is expected to be comparable to USGC resulting in a productivity factor of 1.0.

#### **4.3.4 Labor Availability**

Labor is based on a 50-hour work-week (5-10s). The estimate also includes an allowance of \$75/day for travel and per diem. No additional incentives have been included to attract or retain craft labor. The estimate is based on an adequate supply of qualified craft personnel being available to staff this project.

#### **4.3.5 Construction Indirect Costs**

In addition to base wage rates and fringe benefits, labor costs include construction indirect costs consisting of:

- Payroll taxes and insurances
- Contractor's General Liability insurance
- Construction supervision
- Indirect craft labor
- Temporary facilities
- Field office
- Small tools & consumables
- Material handling
- Safety / incentives
- Mobilization / demobilization
- Premium time portion of extended work week
- Craft bussing within the construction site
- Construction rental equipment
- Fuel, oil & maintenance for construction equipment

- Contractor's overhead and profit (on labor-related costs)

### 4.4 Clarifications

#### 4.4.1 Civil / Structural

- The site is relatively flat. No underground obstructions, rock formations, or unusual site conditions exist.
- All grading will be balanced across the site.
- Earthwork (rough grading) is based on 1 ft of earth movement over the entire solar field site.
- Site geography is assumed to have an average slope between 1% and 2% and can be graded with conventional equipment.
- Topsoil removal is not required. The topsoil will be scarified and compacted.
- Approximately 1,568 acres (6,345,496 m<sup>2</sup>) of land will be cleared and grubbed. Desert vegetation (shrubs, etc.) covers the entire site.
- De-watering is not required.
- The power block and two (2) radial access roads will be paved (asphalt).
- Soil binder/stabilizer is not included for dust control at solar field roads.
- The entire site will be fenced with 8 foot (2.4 m) high chain link fencing with barbed wire.
- The evaporation ponds will have a double HDPE liner. A leak detection system is included.
- The detention pond will be unlined with a compacted native soil bottom.
- Concrete foundations are based on 4,000 psi concrete. Piles are not required. Heliostat piles, if required, are part of NREL scope.
- Concrete foundations are included for all equipment and buildings.
- The steam turbine and ancillary equipment will be indoors.
- Steam turbine, SGS system, electrical, administration & maintenance, and warehouse buildings are included.
- An on-site heliostat fabrication facility is excluded (NREL scope).
- Sanitary waste will not be piped offsite; rather it will run through a septic tank and run through an onsite leach field.

#### 4.4.2 Mechanical / Piping

- The steam turbine is housed in the steam turbine building.
- The tower structure is based on a turnkey design, furnish & erect contract.
- The salt fill will be delivered in one-tonne "supersacs". The cost for salt melting equipment (temporary) and labor are included. Salt melting energy is excluded in cost estimate but is provided in Appendix F - Other O&M Energy for LCA information.
- Stress relieving for piping is included as required by code.
- Underground steel pipe is coated and wrapped.
- Expansion loops for piping systems where required are included.
- Water supply will be provided by three water wells, assumed to be located 200 ft from the heliostat field perimeter.
- Water quality information is unknown and therefore minimal pre water treatment is included and post treatment is excluded.
- A wind fence is excluded.
- Fire protection equipment is excluded from the solar field. Only power block equipment is protected.
- Heliostat costs are part of NREL's scope and not included in this estimate.
- Natural gas piping is not required for this project and therefore not included.

### **4.4.3 Electrical / Instrumentation**

- A 13.8kV-230kV generator step-up transformer is included.
- An on-site switchyard with 230kV main circuit breaker and main disconnect switches is included.
- No transmission lines beyond the switchyard are included.
- The estimate includes auxiliary transformers and station service transformers, the sizing of which includes the heliostat parasitic load.
- All power and control cabling, wiring and fiber optic for the heliostat field is excluded (NREL scope). Heliostat drive power converters are also not included.
- Emergency diesel generators are included and their sizing includes heliostat power consumption.
- Power Distribution Center (PDC) buildings and equipment are included.
- Underground power block area duct bank is included.
- Cathodic protection is included for underground piping.

### **4.4.4 Other**

- EPCM work assumes that the selected site is void of all fatal-flaws which could significantly impact project cost and schedule. These flaws include, but are not limited to: habitat and locations of threatened-endangered and sensitive species, abundance of other protected (e.g., native) species, distribution of noxious weeds, areas of critical wildlife habitats and movement corridors, contaminated soil or hazardous materials, archaeological artifacts, distribution and significance of cultural resources, Native American Tribal concerns, recreational areas, special land use designations (e.g., Bureau of Land Management (BLM) Areas of Environmental Concern), and others.

## **4.5 Exclusions**

As discussed above, the scope of the estimates is generally limited to scope within the project fence. A list of items excluded from the estimate is as follows:

- Demolition and removal of existing structures
- Import duties & tariffs
- Extraordinary noise mitigation or attenuation
- Owner's Costs
- Allowance for funds used during construction
- All taxes with the exception of payroll taxes
- All offsite infrastructure costs
- Upgrades to existing rail spur to accommodate delivery of large equipment
- Temporary housing and facilities for the construction workers

### **4.5.1.1. Typical Owner's Costs**

Owner's costs are excluded from the estimate. Typical Owner's costs include, but are not limited to, the following:

- Permits & Licensing
- Land Acquisition / Rights of Way Costs
- Economic Development
- Project Development Costs (Geotechnical Investigation & Site Survey)
- Legal Fees
- Owner's Engineering / Project & Construction Management Staff



- Plant Operators during start-up
- Electricity consumed during start-up
- Fuel and Reagent consumed during start-up (the salt melting fuel, propane, is included in the O&M LCA information)
- Initial Fuel & Reagent Inventory (salt is included in the cost estimate and construction LCA information)
- Transmission Interconnections & Upgrades
- Operating Spare Parts
- Financing Costs

### 4.6 Tower Cost & Height Formula

Data and a formula for the cost of a concrete solar power tower as a function of tower height was developed and can be found in Appendix H - Variable Tower Height Cost Information. NREL provided three additional and separate sets of receiver and tower design data for a 50MW, 100MW, and 150MW (net) reference solar power plant. This data was used to design and develop cost estimates for three additional towers used for the minimum, midpoint and maximum height reference towers. The receiver design used for the base portion of this task was adjusted for the different thermal duties, salt flow-rates, and receiver dimensions. The base salt piping design was adjusted for flow-rate and tower height and the base cabling/conduit length was adjusted for tower height. The weights of these adjusted systems were used to design the three different towers and associated foundations. The total material and labor costs of the three towers was calculated and a formula was developed as a function of the tower height as defined in the NREL's SAM model. The SAM model defines tower height as the distance from the heliostat hinge point to the center of the receiver. For this analysis a fixed hinge point height of 7 meters above grade was used.

## 5. APPENDICES INFORMATION

Appendix A – Process Flow Diagram: The diagram illustrates the major flow paths of the plant design. The Molten Salt is represented by the red lines, steam flows are blue, water flows are black, and air flows are black. The only air flows on the diagram are the pressurization air to the receiver inlet air vessel and the air removed from the top of the ACC by the steam jet air ejector.

Appendix B - Major Equipment List: This does not contain weights and is simply supplied for information to show which equipment falls under each “subsystem”. The green hi-lighted areas are the major categories as designated in SAM. The grey highlighted areas are the subsystems and the un-highlighted areas are the major equipment items under its respective subsystem.

Appendix C – Capital Cost Estimate Summary: +/- 40% EPCM cost estimate broken down by the NREL SAM major subsystems.

Appendix D – Water Usage: Plant annual water usage. A wet surface air cooler (WSAC) is utilized for some of the auxiliary cooling heat rejection. This information is not included in Appendix “J”.

Appendix E – Specialized Equipment: The major specialized O&M equipment is provided in this appendix. Both the heliostat wash water and wash truck fuel consumption is based on information from Sandia as indicated. This information is not included in Appendix “I” or “J”.

Appendix F – O&M Energy: Energy amount and sources required by the plant other than the electric and thermal energy obtained from solar insolation. This information is not included in Appendix “J”.

Appendix G – References: Non-confidential information available to the public. Numerous other confidential sources, both internal and external to WorleyParsons, as well as national codes, standards and specifications (e.g. ANSI, ASME, ASTM) were utilized in the development of this Report.

Appendix H – Variable Tower Costs: The cost of a concrete power tower as a function of height, as described in section 4.6, is provided in this appendix.

Appendix I – Total Mass of Plant Construction Summary: These tables provide the material weights, and civil quantities, required to construct the plant, excluding the heliostat field (although civil works are provided for the field – note foundations are categorized as structural by WorleyParsons). Grading/earthwork quantities and rip-rap are excluded as the site is theoretical and thus this information would necessarily be speculative. Both metric and U.S. customary unit tables are provided. Note that last two columns are expressed volumetrically.

WorleyParsons used the following approach to account for the miscellaneous masses that comprised less than 2% of the total mass of components, equipment, and parts:

- Most of the large equipment overall weights were inclusive of the items composing <2% and the 2% item's mass was assigned to the other more significant materials rather than being excluded.
- Items included in systems generally comprised of commodities (e.g. piping, cable/wiring, structural steel, foundations) generally excluded the weight of items that make up <2% of the component's mass. These 2% items include; gaskets, nuts/bolts, miscellaneous supports (although weight of major pipe supports is included), ties/pins/clamps, portions of grounding grid, portions of tubing, hose, some miscellaneous small bore pipe, some pipe/conduit fittings, some mechanical specialty items (e.g. expansion joints, traps, strainers), some miscellaneous valves, some miscellaneous instruments/wiring, lighting fixtures, cathodic protection, weld filler, paint, primer, some galvanized coatings, some portions of handrail/grating/gates/ladders, signs, landscaping.

Appendix J – O&M Replacement Mass Summary: The O & M Replacement Mass Summary provides the subsystem mass and general material type for the project over a 30 year lifetime, excluding the heliostat field. The mass is expressed in pounds (lbm) with a summary conversion to metric tonnes at the bottom of the table.

The derivation of the O&M replacement information relies on that generated for the parabolic trough under previous Task 5, subtask 2 (WorleyParsons Project 59002505, Report NREL-0-LS-019-0005 Rev 0), where relevant, and as such, many of the same references, vendor assistance information and assumptions were utilized for consistency, including a 30 year plant lifetime.

O&M Consumables are provided as separate Appendices, external to Appendix J. These comprise of Appendix D –Water Usage, Appendix E – Specialized Equipment and Appendix F – Other O&M Energy Requirements.

**APPENDIX A**  
**Conceptual Process Flow Diagram**

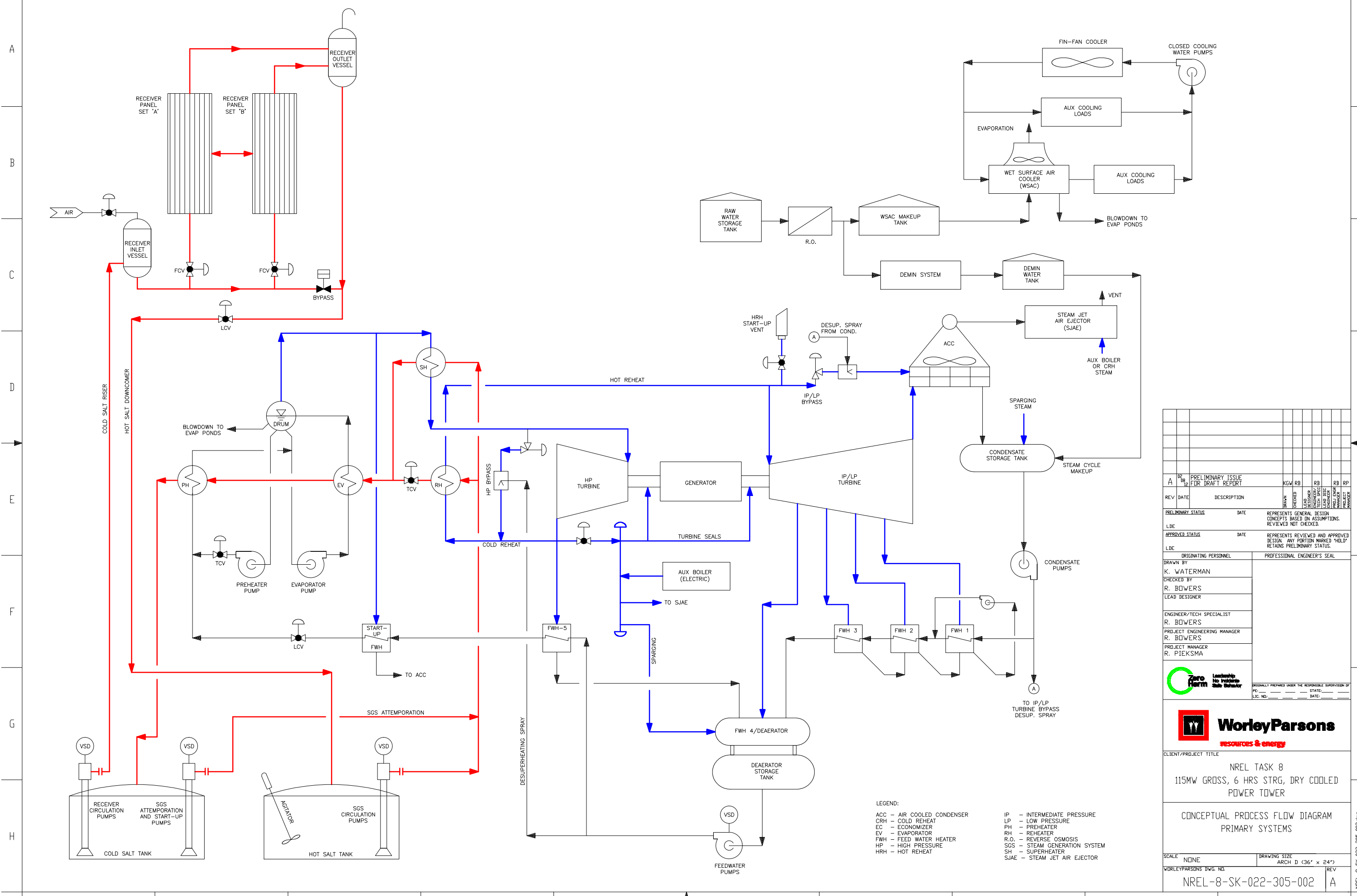

LEGEND:

ACC - AIR COOLED CONDENSER	IP - INTERMEDIATE PRESSURE
CRH - COLD REHEAT	LP - LOW PRESSURE
EC - ECONOMIZER	PH - PREHEATER
EV - EVAPORATOR	RH - REHEATER
FWH - FEED WATER HEATER	R.O. - REVERSE OSMOSIS
HP - HIGH PRESSURE	SGS - STEAM GENERATION SYSTEM
HRH - HOT REHEAT	SH - SUPERHEATER
	SJAIE - STEAM JET AIR EJECTOR

REV DATE	DESCRIPTION	BRWN	CHKD	ENGR	DRG	ISS	APPV	PROJ
A 02/02	PRELIMINARY ISSUE FOR DRAFT REPORT	KGW	RB	RB	RB	RP		

PRELIMINARY STATUS DATE REPRESENTS GENERAL DESIGN CONCEPTS BASED ON ASSUMPTIONS. REVIEWED NOT CHECKED.

APPROVED STATUS DATE REPRESENTS REVIEWED AND APPROVED DESIGN. ANY PORTION MARKED 'HOLD' RETAINS PRELIMINARY STATUS.

DRAWN BY K. WATERMAN	PROFESSIONAL ENGINEER'S SEAL
CHECKED BY R. BOWERS	
LEAD DESIGNER	
ENGINEER/TECH SPECIALIST R. BOWERS	
PROJECT ENGINEERING MANAGER R. BOWERS	
PROJECT MANAGER R. PIEKSMA	

ORIGINALLY PREPARED UNDER THE RESPONSIBLE SUPERVISION OF

PE: \_\_\_\_\_ STATE: \_\_\_\_\_ DATE: \_\_\_\_\_

LIC. NO.: \_\_\_\_\_



CLIENT/PROJECT TITLE

NREL TASK 8  
115MW GROSS, 6 HRS STRG, DRY COOLED  
POWER TOWER

CONCEPTUAL PROCESS FLOW DIAGRAM  
PRIMARY SYSTEMS

SCALE: NONE DRAWING SIZE: ARCH D (36" x 24")

WORLEYPARSONS DWG. NO. NREL-8-SK-022-305-002 REV. A

NREL-8-SK-022-305-002.dwg 08/16/2012

**APPENDIX B**  
**Major Equipment List**

**CLIENT:** NREL of DOE  
**PROJECT:** Power Tower Plant Cost & LCA  
**TITLE:** Major Equipment List  
**REVISION:** 0  
**DATE:** 8/24/2012

Code	ITEM	QTY
<b>01</b>	<b>SITE IMPROVEMENT</b>	
01A	Site Improvement - Site Preparation	
01B	Site Improvement - Clearing & Grubbing	
01C	Site Improvement - Grading, Drainage, Remediation, Retention & Detention	
01C	Site Improvement - Evaporation Pond	1
01D	Site Improvement - Roads, Parking, and Fences	
01E	Site Improvement - Water Supply Infrastructure	
01E	Well Water Forwarding Pumps	3x50%
01E	Piping, Insulation Valves, and Fittings	
<b>02</b>	<b>HELIOSTAT FIELD (BY NREL)</b>	
02A	Heliostat Field - Equipment	
02A	Heliostat Field - Mirrors	6,682
02A	Heliostat Field - Drives	6,682
02A	Heliostat Field - Foundations & Support Structures	6,682
02B	Heliostat Field - Foundations & Support Structures	
02B	Heliostat Field - Foundations	by NREL
02B	Heliostat Field - Support Structures	by NREL
02C	Heliostat Field - Electrical	
02C	Heliostat Field Transformers	by NREL
02C	Heliostat Drive Power Converters	by NREL
02C	Power Supply Cable/Wiring	by NREL
02D	Heliostat Field - Instrumentation & Controls	
02D	Heliostat control sensors, software, and wiring	by NREL
<b>02</b>	<b>TOWER</b>	
02E	Tower - Foundations & Support Structures	
02E	Tower Foundation	1
02E	Tower Structure	1
02F	Tower - Piping, Insulation, Valves, & Fittings	
02G	Tower - Equipment	
02G	Boom Crane	1
02H	Tower - Electrical	
02H	Cable and Conduit	
02I	Tower - Instrumentation & Controls	
02I	Cable and Conduit	
<b>02</b>	<b>RECEIVER</b>	
02J	Receiver - Equipment	
02J	Receiver Structure	1
02J	Receiver Panels	20
02J	Oven Boxes	40
02J	Receiver Inlet Vessel	1
02J	Receiver Outlet Vessel	1
02J	Receiver Overflow Vessel	1
02J	Receiver Air Compressor	1
02K	Receiver - Pumps	
02K	Cold Salt Receiver Circulation Pumps	4x33%
02L	Receiver - Piping, Insulation, Valves, & Fittings	
02M	Receiver - Electrical	
02M	Cable and Conduit	
02N	Receiver - Instrumentation & Controls	
<b>03</b>	<b>THERMAL ENERGY STORAGE SYSTEM (TES)</b>	
03G	TES - Equipment	
03G	Cold Tank Immersion Heaters	4
03G	Hot Tank Immersion Heaters	4
03G	Internal Volume Air Heater System	1
03G	Hot Tank Agitators	4
03H	TES - Tanks	
03H	Cold Nitrate Salt Tank	1
03H	Hot Nitrate Salt Tank	1
03I	TES - Foundations & Support Structures	
03J	TES - Salt Media	
03J	Bulk Salt Storage	19,200 Tons
03K	TES - Piping, Insulation, Valves, & Fittings	
03L	TES - Electrical	
03M	TES - Instrumentation & Controls	
<b>04</b>	<b>STEAM GENERATION SYSTEM (SGS)</b>	
04A	SGS - Pumps	
04A	Steam Generator Evaporator Circulation Pump	2x100%
04A	Steam Generator Preheater Circulation Pump	2x100%
04A	SGS Hot Salt Circulation and Tank Transfer Pumps	3x50%
04A	SGS Cold Salt Attemperation and Tank Transfer Pump	1 x 100%
04B	SGS - Equipment & Heat Exchangers	
04B	Reheater	2 x 50%
04B	Superheater	2 x 50%
04B	Evaporator (Steam generator)	3 x 33%
04B	Preheater (Economizer)	6 x 16%
04B	Steam Drum	1x100%
04C	SGS - Piping, Insulation, Valves, & Fittings	
04D	SGS - Electrical	
04E	SGS - Instrumentation & Controls	
04F	SGS - Foundations & Support Structures	
<b>05</b>	<b>FOSSIL BACKUP</b>	
	N/A	
<b>06</b>	<b>ELECTRIC POWER GENERATION SYSTEM (EPGS)</b>	
06A	Power Block - Steam Turbine Generator Island	
06A	Steam Turbine	1

**CLIENT:** NREL of DOE  
**PROJECT:** Power Tower Plant Cost & LCA  
**TITLE:** Major Equipment List  
**REVISION:** 0  
**DATE:** 8/24/2012

Code	ITEM	QTY
06A	Generator	1
06A	Lube Oil and Hydraulic Oil System	1
06C	Power Block - Blowdown System	
06C	Blowdown & Flash Tank (Shop Fab)	1
06C	Blowdown Piping, Insulation, Valves, & Fittings	
06D	Power Block - Cooling System	
06D	Air Cooled Condenser	1
06D	Steam Air Ejector Skid (SJAE)	1
06E	Power Block - Condensate System	
06E	Condensate - Piping, Insulation, Valves, & Fittings	
06E	Condensate Forwarding Pumps	3x50%
06E	Condensate Storage Tank	1
06F	Power Block - Boiler Feedwater System	
06F	Feedwater - Piping, Insulation, Valves, & Fittings	
06F	LP Feedwater Heater Drains- Piping, Insulation, Valves, & Fittings	
06F	HP Feedwater Heater Drains- Piping, Insulation, Valves, & Fittings	
06F	Feedwater Pumps	2x100%
06F	Closed Feedwater Heaters	4
06F	Feedwater Drain Pumps	2x100%
06F	Deaerator/Storage Tank	1
06F	Feedwater Heater (Start up)	1x100%
06G	Power Block - Auxiliary Cooling / Closed Cooling Systems	
06G	Cooling Systems - Piping, Insulation, Valves, & Fittings	
06G	Wet Surface Air Cooler (WSAC)	1
06G	Fin-Fan Cooler	1
06G	Closed Cooling Water Pumps	2x100%
06G	WSAC Blowdown Pumps (to evap ponds)	2x100%
06G	WSAC Chemical Feed / Storage System	1 Lot
06G	WSAC Makeup Water Tank	1
06G	Closed Cooling Water Expansion Tank (Shop Fab)	1
06H	Power Block - Steam Piping, Insulation Valves and Fittings	
06H	Main Steam - Piping, Insulation, Valves, & Fittings	
06H	Cold Reheat - Piping, Insulation, Valves, & Fittings	
06H	Hot Reheat - Piping, Insulation, Valves, & Fittings	
06H	Auxiliary, Extraction Steam, Vents & Drains - Piping, Insulation, Valves, & Fittings	
06J	Power Block - Water Treatment Systems	
06J	Service Water - Piping, Insulation, Valves, & Fittings	
06J	Service Water Pumps (from Raw/Fire water Tank)	2x100%
06J	Demin Feed Pumps	2x100%
06J	Demineralized Water Treatment System	1 Lot
06J	Demin Forwarding Pumps (cycle makeup)	2x100%
06J	Demin Startup/Cycle Make-up Pump	1x100%
06J	Raw/Service/Fire Water Storage Tank (Field Erected)	1
06J	Demineralized Water Storage Tank (Field Erected)	2
06J	Potable Water Pumps	2x100%
06J	Oil/Water Separator Effluent Forwarding Pumps	2x100%
06J	Potable Water Storage Tank (Shop Fab)	1
06J	Oil/Water Separator Tank	1
06J	Water Sample Panel Skid	1
06J	Sanitary/Industrial Waste Systems	1
06K	Power Block - Power Distribution Systems	
06K	Generator Step-Up Transformer	1
06K	Unit Auxiliary Transformer	2
06L	Power Block - Backup Power Systems	
06L	Emergency Diesel Generator	3
06M	Power Block - Instrumentation and Controls	
06M	Distributed Control System	1
06N	Power Block - Fire Protection System	
06N	Fire Protection - Piping, Insulation, Valves, & Fittings	
06N	Firewater Forwarding Pump (Electric Driven)	1x100%
06N	Firewater Jockey Pump (Pressure Maintenance)	1x100%
06N	Emergency Diesel-Driven Firewater Pump	1x100%
06O	Power Block - Foundations & Support Structures	
06P	Power Block - Buildings	
06Q	Power Block - BOP Mechanical Systems	
06Q	BOP - Piping, Insulation, Valves, & Fittings	
06Q	Electric Auxiliary Boiler	1
06Q	Instrument/Service Air Compressors	2x100%
06Q	Diesel Fuel Tank & Pump System (On-site Maintenance Trucks)	1
06Q	Turbine Area Flash Tank (Shop Fab)	1
06R	Power Block - BOP Electrical Systems	

## **APPENDIX C**

### **Power Tower Plant Capital Cost Summary: Materials and Labor**



# ESTIMATE SUMMARY

(Using Arizona merit shop labor rates)  
**NREL Task 8 Solar Power Tower Cost Assessment**  
**100 MW net with Thermal Storage - Dry Cooled**

10/8/2012

Revision 2 - RCP

ITEM	QTY	UNIT	MATERIAL	LABOR	TOTAL	COMMENTS
01	1	LS	\$ 6,849,000	\$ 12,480,000	\$ 19,329,000	
02	1	LS	\$ 45,931,000	\$ 25,577,000	\$ 71,508,000	
03	1	LS	\$ 50,495,000	\$ 5,745,000	\$ 56,240,000	
04	1	LS	\$ 31,001,000	\$ 10,944,000	\$ 41,945,000	
05	1	LS	\$ -	\$ -	\$ -	
06	1	LS	\$ 87,244,000	\$ 27,747,000	\$ 114,991,000	
07	1	LS			\$ 29,001,000	Professional services
08	1	LS			\$ -	Excluded
09	1	LS			\$ -	Excluded
			Subtotal			
			\$ 221,520,000	\$ 82,493,000	\$ 333,014,000	
					\$ 31,680,000	
<b>TOTAL ESTIMATE - EPCM BASIS</b>					<b>\$ 364,694,000</b>	

**CRITICAL NOTES**

Labor rates are merit shop-based for Arizona with a productivity factor of 1.0

## **APPENDIX D**

### **Water Usage**

## Water Usage

Item Description	Annual Water Consumption (Acre-Feet / Year)	Annual Water Consumption (Cubic Meters / Year)
Heliostat Water Wash	45	56,000
Steam Cycle & Balance of Plant (BOP)	55	68,000
<b>Total</b>	100	124,000

### Assumptions/Notes:

1. Water Consumption calculation includes water treatment equipment efficiency losses; no waste water treatment system assumed.
2. Heliostat water wash consumption estimated from Sandia Report SAND2007-3293, Appendix "A", from Scott Jones' Memo; "Estimating the Present Value of Collector Washing Costs at a Solar Plant" using a blend of Solar Two and Kramer Junction Company (KJC) data.
3. Water consumption excludes possible periodic dust suppression/palliative applications.
4. Water treatment chemical usage is minor and is roughly estimated at 5,000 lb/yr (2,300 kg/yr).

**APPENDIX E**  
**Specialized Equipment List**

### Specialized Equipment

Item description	Quantity	Fuel Economy (mpg)	Fuel Type	Annual mileage (per truck)	Annual Fuel Consumption (gal/yr)	Annual Fuel Consumption (liters/yr)
Heliostat Water Wash Trucks	14		Diesel		31,300	118,000
General Maintenance: 3/4 Ton truck (note 2)	4	15	Gasoline	800	213	810

**Assumptions/Notes:**

1. Heliostat water wash truck annual fuel consumption estimated from Sandia Report SAND2007-3293, Appendix "A", from Scott Jones' Memo; "Estimating the Present Value of Collector Washing Costs at a Solar Plant" using a blend of Solar Two and Kramer Junction Company (KJC) fuel usage data.
2. General maintenance vehicles are estimated here based on conventional plant site experience. These general maintenance vehicles can be specified to meet most plant needs.
3. Use of all other O & M vehicles such as man lifts, scissor lifts, and forklifts is considered infrequent and fuel consumption considered negligible compared to the Wash and General Maintenance vehicles fuel consumption.

## **APPENDIX F**

### **Other O&M Energy Requirements**

### Other O & M Energy Requirements

Item	Source	Quantity	
Auxiliary Electricity	Grid	17,600	MW-hr/year
Propane (Initial 1st year salt melting only)	Portable/temporary	124,000	Gallon
Natural gas	N/A	0	MMBtu/year

**Assumptions/Notes:**

1. Auxiliary electricity is off-line power consumption backfed from the grid; the bulk of the consumption is utilized in the heating of various salt systems.
2. Natural gas use is N/A due to assumed implementation of an electric auxiliary boiler.
3. Diesel fuel required for any Specialized Equipment is excluded here.
4. Portable propane trailer(s) were assumed for initial salt melting.
5. Nitrogen usage for the Steam Generation System and any other steam systems layup is minor.
6. MMBtu = Million Btu

## **APPENDIX G**

### **References**



**The below references represent non-confidential information available to the public. Numerous other confidential sources, both internal and external to WorleyParsons, as well as national codes, standards and specifications (e.g. ANSI, ASME, ASTM) were utilized in the development of this Report.**

1. Kelly, B. and Kearney, D., "Thermal Storage Commercial Plant Design Study for a 2-Tank Indirect Molten Salt System," NREL/SR-550-40166, July 2006.
2. Litwin, R.Z., "Receiver System: Lessons Learned from Solar Two," SAND2002-0084, March 2002.
3. Reilly, H.E., and G.J. Kolb, "An Evaluation of Molten-Salt Power Towers Including Results of the Solar Two Project," SAND2001-3674, November 2001.
4. Zavoico, A.B., "Solar Power Tower Design Basis Document," SAND2001-2100, July 2001.
5. Turchi, Craig, NREL. "NREL Power Tower for WP Task 8 study SAM-2011-12-02.zsam." SAM model file sent to Ryan Bowers. February 15, 2012. E-mail.
6. Kolb, G.J. et al., "Heliostat Cost Reduction Study", SAND2007-3293, June 2007.
7. WorleyParsons, "CSP Parabolic Trough Plant Cost Assessment," Technical report and supplemental documents, WorleyParsons Group, Denver, Report No. 59002501-NREL-0-LS-019-0001, Sept 2009.
8. WorleyParsons, "Material Input for Life Cycle Assessment," Technical report and supplemental documents, WorleyParsons Group, Denver, Report No. 59002505-NREL-0-LS-019-0005, Jan 2010.
9. *All City Fence Co. Chain Link Fabric.* (2011). Retrieved from [http://www.allcityfence.com/material/chain\\_link.html](http://www.allcityfence.com/material/chain_link.html)
10. *Aluminum Roll Jacketing.* (2008). Retrieved from <http://idealproducts.ca/pdf/alumpaint.pdf>
11. *ASC Steel Floor Deck.* (2012). Retrieved from <http://www.ascsd.com/files/FloorDeck.pdf>
12. *Bonney Forge® Cast Steel Valves.* (2012). Retrieved from <http://bonneyforge.com/resources/CSV.pdf>
13. *Bonney Forge® Class 800/1500 lb Gate Valves-Bolted Bonnet-Full & Reduced Port.* (2012). Retrieved from [http://bonneyforge.com/specs/forged/800\\_1500lb\\_GateValve.pdf](http://bonneyforge.com/specs/forged/800_1500lb_GateValve.pdf)
14. *CALICO Industrial Fixed Cage Ladders.* (2012). Retrieved from [http://www.calicoladders.com/fixed\\_ladders.html](http://www.calicoladders.com/fixed_ladders.html)
15. *CAVCO Pipe Valves & Fittings HDPE Pipe Sizes.* (2012). Retrieved from [http://cavcovalve.com/Resources\\_files/hdpe%20pipe%20chart%201%20.pdf](http://cavcovalve.com/Resources_files/hdpe%20pipe%20chart%201%20.pdf)
16. *Chromalox® Mineral Insulated Cable.* (2012). Retrieved from <http://www.chromalox.com/catalog/resources/MOD-MI.pdf>
17. *Crane® Cast Steel Valves – Technical Datasheet.* (2012). Retrieved from <http://www.craneenergy.com/energy/products/multi-turn-valves/cast-steel-valves/crane-cast-steel-valves>
18. *DOWFROST HD Propylene Glycol-based Heat Transfer Fluid.* (2012). Retrieved from <http://www.dow.com/heattrans/products/glycol/dowfrost.htm>
19. *Fiberglass Technical Data.* (n.d.). Retrieved from <http://thermostatic.com/techdata/fiberglassdata.shtml>
20. *FILMTEC™ Membranes – Element Weight.* (July 2012). Retrieved from [https://dow-answer.custhelp.com/app/answers/detail/a\\_id/213/kw/FILMTEC](https://dow-answer.custhelp.com/app/answers/detail/a_id/213/kw/FILMTEC)
21. *FILMTEC™ Membranes, FILMTEC BW30-365-FR Fouling Resistant RO Element, Form No. 609-00368-1008.* (2011). Retrieved from [http://msdssearch.dow.com/PublishedLiteratureDOWCOM/dh\\_0613/0901b80380613ea6.pdf?filepath=liquadseps/pdfs/noreg/609-00368.pdf&fromPage=GetDoc](http://msdssearch.dow.com/PublishedLiteratureDOWCOM/dh_0613/0901b80380613ea6.pdf?filepath=liquadseps/pdfs/noreg/609-00368.pdf&fromPage=GetDoc)

22. *Flowserve® Edward Forged Steel Valves*. (2012). Retrieved from <http://flowserve.com/files/Files/Literature/ProductLiterature/FlowControl/Edward/EVENCT0001.pdf>
23. *General Cable Industrial Cable Catalog*. (January 2010). Retrieved from <http://www.generalcable.com/GeneralCable/en-US/Products/IndustrialCables/Catalog>
24. *General Cable Fiber Optic Cable Catalog*. (December 2010). Retrieved from <http://www.generalcable.com/GeneralCable/en-US/Products/FiberOpticCables>
25. *GEOTEX® 2130 Polypropylene fabric*. (2012). Retrieved from <http://geotextile.com/downloads/Geotex%202130%20Product%20Data%20Sheet.pdf>
26. *GEOTEX® 2x2HF Polypropylene fabric*. (2012). Retrieved from <http://geotextile.com/downloads/Geotex%202x2HF%20Product%20Data%20Sheet.pdf>
27. *Grating Pacific Welded Steel Bar Grating*. (2012). Retrieved from [http://www.gratingpacific.com/load\\_tables/catalogs/metal-bar-grating.pdf](http://www.gratingpacific.com/load_tables/catalogs/metal-bar-grating.pdf)
28. *Industrial Insulation Group, LLC Thermo-12 Gold Pipe & Block Insulation*. (November 2008). Retrieved from <http://www.spi-co.com/paragonpacific/images/IIG300.pdf>
29. *Industrial Insulation Group, LLC MinWool-1200 Pipe and Tank Wrap*. (2012). Retrieved from <http://www.iig-llc.com/pdfs/IIG-415-Mineral-Wool-1200-Pipe-and-Tank-Wrap.pdf>
30. *Newco - Cast Steel Bolted Bonnet Valve*. (2012). Retrieved from [http://www.superiorvalves.com/pdf/NEWCO\\_CastSteelBoltedBonnet\\_GGCA\\_Catalog.pdf](http://www.superiorvalves.com/pdf/NEWCO_CastSteelBoltedBonnet_GGCA_Catalog.pdf)
31. *Nexans Instrumentation Cable*. (2012). Retrieved from [http://www.nexans.com.mx/eservice/CentralAmerica-es\\_MX/fileLibrary/Download\\_540152129/CentralAmerica/files/Instrumentation\\_2.pdf](http://www.nexans.com.mx/eservice/CentralAmerica-es_MX/fileLibrary/Download_540152129/CentralAmerica/files/Instrumentation_2.pdf)
32. *Reinforced Concrete Pipe*. (March 15, 2006). Retrieved from [http://www.hansonpipeandprecast.com/tech\\_specs/VA/02.05\\_12\\_36\\_B\\_Wall.pdf](http://www.hansonpipeandprecast.com/tech_specs/VA/02.05_12_36_B_Wall.pdf)
33. *ROXUL® Mineral Fiber Block and Board Thermal Insulation*. (March 2010). Retrieved from <http://www.roxul.com/files/RX-NA-EN/pdf/RHT80-3-30-10.pdf>
34. *Southwire Bare Copper Wire and Cable*. (1998). Retrieved from <http://www.southwire.com/products/ProductCatalog.htm>
35. *TENAX GNT 1300 Geonets Mesh Drainage Media*. (2012). Retrieved from [http://www.tenax.net/pdf\\_geo\\_e/gnt1300\\_e.pdf](http://www.tenax.net/pdf_geo_e/gnt1300_e.pdf)
36. *Tioga Pipe Chart*. (2012). Retrieved from <http://www.tiogapipe.com/TiogaChart.pdf>
37. *USA Wire & Cable, INC. 20-10 Control Cable*. (n.d.). Retrieved from [http://www.usawire-cable.com/pdfs/20\\_10%2014-10AWG.pdf](http://www.usawire-cable.com/pdfs/20_10%2014-10AWG.pdf)

**APPENDIX H**  
**Tower Height Cost Information**

**CLIENT** NREL of DOE  
**PROJECT** Power Tower Plant Cost & LCA  
**TITLE** Variable Tower Cost  
**ORIGINATOR** Bob Piekma  
**REVIEWER** Ryan Bowers  
**REVISION** A  
**DATE** 6/19/2012

Tower Height, Meters (SAM Definition)	122	178	217
Total Material	\$11,005,236	\$18,986,234	\$28,186,228
Total Labor	\$9,600,323	\$16,450,185	\$24,380,024
Total Cost	\$20,605,559	\$35,436,419	\$52,566,252

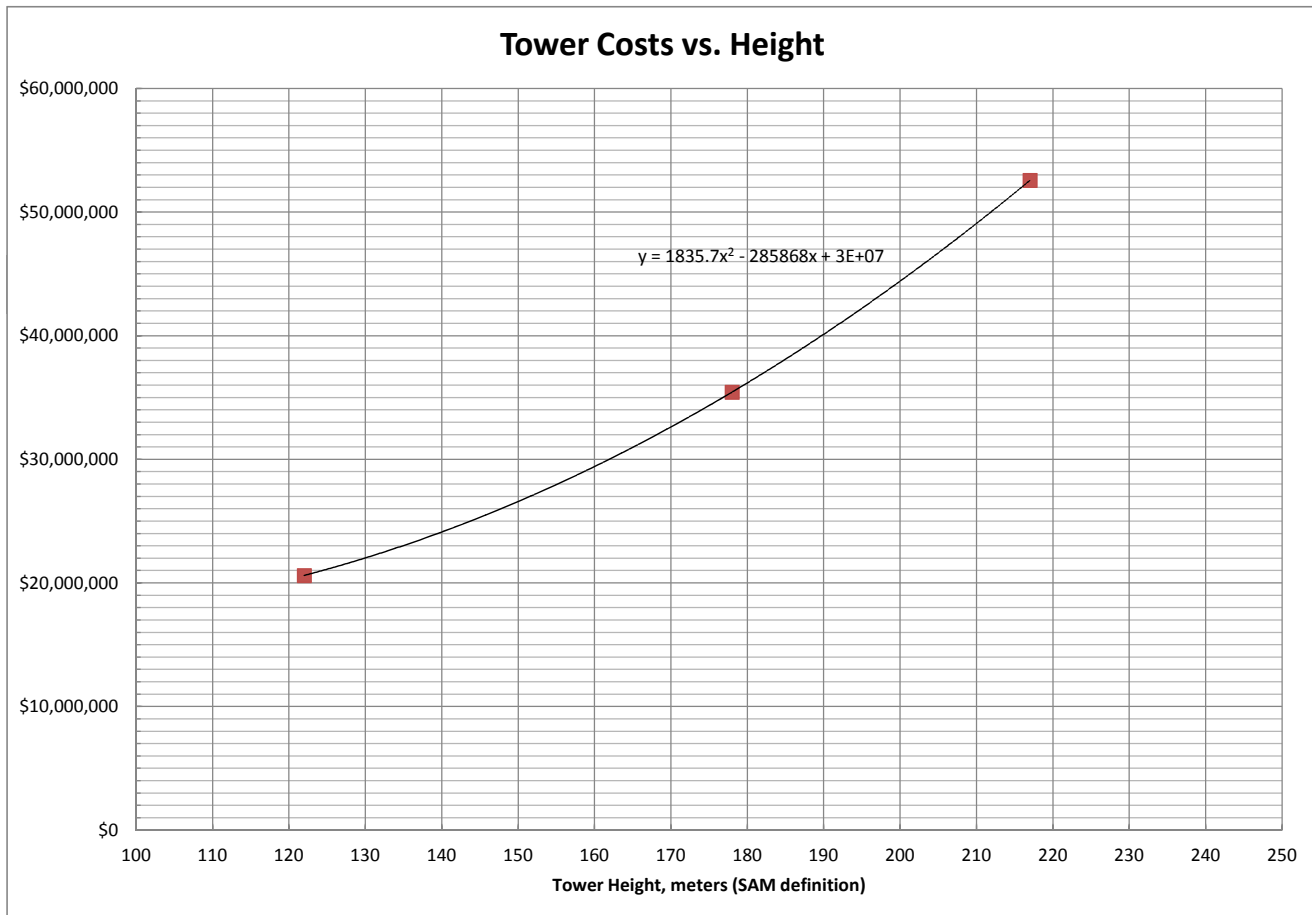

**APPENDIX I**

**Total Mass of Plant Construction Summary**

**CLIENT** NREL of DOE  
**PROJECT** Power Tower Plant Cost & LCA Input  
**TITLE** Plant Capital Cost LCA Data - METRIC  
**REVISION** 1  
**DATE** 10/8/2012

ITEM	Carbon Steel, Iron & Zinc <small>[Metric Tonnes]</small>	Stainless Steel <small>[Metric Tonnes]</small>	Alloy Steel <small>[Metric Tonnes]</small>	Copper <small>[Metric Tonnes]</small>	Aluminum <small>[Metric Tonnes]</small>	Insulation <small>[Metric Tonnes]</small>	Plastics <small>[Metric Tonnes]</small>	Oils, Lubricants <small>[Metric Tonnes]</small>	Salt <small>[Metric Tonnes]</small>	Concrete <small>[Metric Tonnes]</small>	Asphalt <small>[Cubic Meters]</small>	Crushed Stone/ Gravel <small>[Cubic Meters]</small>
SITE IMPROVEMENT TOTALS	103	3	1	1	0	0	399	0	0	624	3,876	46,609
HELIOSTAT FIELD TOTALS (BY NREL)												
TOWER TOTALS	2,811	97	5	2	2	40	1	0	0	53,033	0	0
RECEIVER TOTALS	384	137	70	40	4	88	14	0	0	0	0	0
THERMAL ENERGY TOTALS	524	452	2	10	17	1,069	3	0	17,418	2,879	0	0
STEAM GENERATION SYSTEM TOTALS	2,794	254	8	68	7	27	15	0	0	10,080	0	0
ELECTRIC POWER GENERATION TOTALS	4,907	67	249	185	257	53	115	95	0	12,213	0	280
<b>SOLAR POWER TOWER PLANT TOTALS</b>	<b>11,524</b>	<b>1,011</b>	<b>335</b>	<b>306</b>	<b>287</b>	<b>1,276</b>	<b>545</b>	<b>95</b>	<b>17,418</b>	<b>78,828</b>	<b>3,876</b>	<b>46,889</b>

**APPENDIX J**  
**O&M Replacement Mass Summary**

# OPERATIONS & MAINTENANCE SCHEDULE

Assumed Plant Life [yr.]    30

Client: NREL of DOE  
 Project: Power Tower Plant Cost & LCA Input  
 Title: O&M Schedule  
 Date: 9/4/2012  
 Rev: 0

## Replacement Materials / Weights (lb)

Major Subsystem	Lifetime Repl Weight (lb)	Carbon Steel	Stainless Steel	Alloy	Graphite Packing / Gasket	Copper	Salt	FRP	Oil	Other
<b>SITE IMPROVEMENTS</b>	<b>4,159</b>	1,224	290	0	29	2,573	0	0	0	44
<b>HELIOSTAT FIELD-BY NREL</b>										
<b>TOWER / RECEIVER</b>	<b>203,739</b>	26,593	4,386	98,161	39,734	33,674	0	0	0	1,191
<b>THERMAL ENERGY STORAGE SYSTEM</b>	<b>1,126,692</b>	2,057	1,804	6,754	0	708	1,113,600	0	0	1,769
<b>STEAM GENERATION SYSTEM</b>	<b>143,698</b>	15,592	93,000	1,283	8,995	24,001	0	0	0	827
<b>ELECTRIC POWER GENERATION SYSTEM - POWER BLOCK</b>	<b>493,999</b>	80,092	25,765	9,773	157	29,168	0	34,000	303,512	11,519
<b>TOTALS (LB)</b>	<b>1,972,288</b>	125,557	125,245	115,970	48,915	90,124	1,113,600	34,000	303,512	15,350
<b>TOTALS (Metric Tonnes)</b>	<b>894.6</b>	57.0	56.8	52.6	22.2	40.9	505.1	15.4	137.7	7.0

### Major Assumptions & Clarifications

1. Air Cooled Condenser (ACC) tube bundles do not need replacement.
2. Refer to Water Usage, Specialized Equipment, and Other O&M Energy for consumables.
3. Salt replacement occurs at a rate of 0.1% per year.
4. Building and grounds maintenance is excluded, e.g. roof replacements, road resurfacing, etc.