**Pacific Northwest
National Laboratory**

Operated by Battelle for the
U.S. Department of Energy

**Federal Emergency Management
Information System (FEMIS)**

Data Management Guide

for

FEMIS Version 1.4.6

June 25, 1999

**RECEIVED
JUL 21 1999
OSTI**



Prepared for the U.S. Department of Energy
under Contract DE-AC06-76RLO 1830

Acknowledgment

The FEMIS product is being developed by the Pacific Northwest National Laboratory as part of the U.S. Army's Chemical Stockpile Emergency Preparedness Program (CSEPP).

This software and its documentation were produced with Government support under Contract Number DE-AC06-76RLO-1830 awarded by the United States Department of Energy. The Government retains a paid-up non-exclusive, irrevocable worldwide license to reproduce, prepare derivative works, perform publicly and display publicly by or for the Government, including the right to distribute to other Government contractors.

Disclaimer

This material was prepared as an account of work sponsored by an agency of the United States Government. Neither the United States Government nor the United States Department of Energy, nor Battelle Memorial Institute, nor any of their employees, **MAKES ANY WARRANTY, EXPRESSED OR IMPLIED, OR ASSUMES ANY LEGAL LIABILITY OR RESPONSIBILITY FOR THE ACCURACY, COMPLETENESS, OR USEFULNESS OF ANY INFORMATION, APPARATUS, PRODUCT, SOFTWARE, OR PROCESS DISCLOSED, OR REPRESENTS THAT ITS USE WOULD NOT INFRINGE PRIVATELY OWNED RIGHTS.**

References to any specific commercial product, process or service by trade name, trademark, manufacturer, or otherwise does not necessarily constitute or imply endorsement, recommendation, or favoring by the U.S. Army or Battelle.

The software has not been reviewed for export out of the U.S. A license or license exception may be required for export.



Federal Emergency Management Information System (FEMIS)

Data Management Guide for FEMIS v1.4.6

LK Angel	RL Johnson
JC Bower	SM Johnson
RA Burnett	RM Loveall
TR Downing	WD Millard
PM Fangman	SA Schulze
M Hoza	BM Wood
DM Johnson	

June 25, 1999

Prepared for
the U.S. Department of Energy
under Contract DE-AC06-76RLO 1830

Pacific Northwest National Laboratory
Richland, Washington 99352



DISCLAIMER

Portions of this document may be illegible in electronic image products. Images are produced from the best available original document.

Preface

The Federal Emergency Management System (FEMIS) is an emergency management planning and response tool. The following documents were developed to support system users.

This *FEMIS Data Management Guide* provides the information needed to manage the data used to support the administrative, user-environment, database management, and operational capabilities of FEMIS.

The *FEMIS Installation Guide* provides instructions for installing and configuring the FEMIS software package.

The *FEMIS System Administration Guide* provides information on FEMIS System Administrator activities as well as the utilities that are included with FEMIS.

The *FEMIS Release Notes* provide a description of what is new in the release, a list of known problems and workaround suggestions, and any information specific to this release that was not available when other documents were published.

The *FEMIS Bill of Materials* defines FEMIS hardware, software, and communication requirements.

The *FEMIS Online Help System* explains how to use the FEMIS program, which is designed to help civilian emergency management personnel to plan and respond to a Chemical Accident or Incident (CAI) Event at a military chemical stockpile.^(a)

(a) The FEMIS program is being developed by the Pacific Northwest National Laboratory as part of the U.S. Army Chemical Stockpile Emergency Preparedness Program (CSEPP). Pacific Northwest National Laboratory is operated for the U.S. Department of Energy by Battelle under Contract DE-AC06-76RLO 1830.

Contents

1.0	Overview.....	1-1
1.1	Point of Contact.....	1-3
1.2	Document Organization.....	1-3
1.3	Software Products	1-4
2.0	Resource Documents	2-1
3.0	Building the Initial Information	3-1
3.1	Site Survey.....	3-3
3.2	Building Relational Data	3-3
3.3	Building Spatial Data	3-4
3.3.1	Data Sources and Import Processing.....	3-7
3.3.1.1	Facilities.....	3-13
3.3.1.2	Accident Based Planning Wedges.....	3-13
3.3.1.3	D2PC Plume Themes.....	3-13
3.3.1.4	Evacuation Themes	3-13
3.3.1.5	Census Blocks	3-13
3.3.1.6	County Boundaries	3-14
3.3.1.7	Accident-Based Planning Categories	3-14
3.3.1.8	Igloos (Point Locations).....	3-14
3.3.1.9	Emergency Planning Zones	3-14
3.3.1.10	Depot Zones	3-14
3.3.1.11	Traffic Control Points.....	3-15
3.3.1.12	Known Points.....	3-15
3.3.1.13	Met Towers	3-15
3.3.1.14	Warning Sirens.....	3-15
3.3.1.15	Administrative Boundaries	3-15
3.3.1.16	Road Themes (Detailed, Major).....	3-16
3.3.1.17	Railroads.....	3-16
3.3.1.18	Streams and Water Bodies	3-16
3.3.1.19	Elevation Contours	3-16
3.3.1.20	Image Maps.....	3-16
3.3.1.21	Other Themes.....	3-17
3.3.2	TIGER/Line Data	3-17
4.0	Managing Relational Data	4-1
4.1	Site Default Information and Considerations.....	4-1
4.2	FEMIS Data Manager Tool.....	4-2
4.2.1	Data Control	4-3
4.2.2	DBGrid Control	4-4
4.2.3	Other Data Manager Functions.....	4-5

4.3	Managing Relational Data.....	4-5
4.3.1	Database Integrity.....	4-5
4.3.2	Testing Modifications.....	4-5
4.3.3	Exercise Data.....	4-5
4.3.4	Archiving Tables.....	4-6
4.3.5	Backup and Recovery of the Database.....	4-8
4.4	Data Sharing Between EOCs.....	4-8
4.4.1	Depot Owned Tables.....	4-9
4.4.2	Site-wide Shared Tables.....	4-9
4.5	Security Provisions.....	4-12
5.0	Managing Spatial Data.....	5-1
5.1	System Spatial Datasets.....	5-1
5.1.1	Census Blocks.....	5-2
5.1.2	County Boundaries.....	5-2
5.1.3	Accident-Based Planning Categories.....	5-2
5.1.4	Igloos (Point Theme).....	5-2
5.1.5	Emergency Planning Zones.....	5-2
5.1.6	Depot Zones.....	5-3
5.1.7	Met Towers.....	5-3
5.1.8	Administrative Boundaries.....	5-3
5.1.9	Road Themes (Detailed, Major).....	5-3
5.1.10	Railroads.....	5-3
5.1.11	Streams and Water Bodies.....	5-4
5.1.12	Elevation Contours.....	5-4
5.1.13	Image Maps.....	5-4
5.2	User-Modifiable Spatial Datasets.....	5-4
5.2.1	Facilities.....	5-4
5.2.2	Traffic Control Points.....	5-4
5.2.3	Siren.....	5-5
5.2.4	Known Points.....	5-5
5.3	Model-Related Spatial Datasets.....	5-5
5.3.1	D2PC Theme Data (Plume Contours).....	5-5
5.3.2	Threat Area Wedge Theme Data.....	5-5
5.3.3	Evacuation Theme Data.....	5-6
6.0	Managing Exercise Data.....	6-1
6.1	Selecting Exercise Modes.....	6-1
6.2	Creating an Exercise.....	6-2
6.3	Modifying an Exercise.....	6-4
6.4	Deleting an Exercise.....	6-4
7.0	Managing Meteorological (Met) Data.....	7-1

8.0	Managing Evacuation (Evac) Data.....	8-1
8.1	Creating an Evacuation Case	8-1
8.2	Opening an Existing Case.....	8-2
8.3	Saving an Evacuation Case.....	8-2
8.4	Deleting an Evacuation Case	8-3
8.5	Importing an Evacuation Case	8-4
8.6	Importing Incomplete Evacuation Cases	8-5
8.7	Exporting an Evacuation Case	8-6
9.0	Managing D2PC Model Data.....	9-1
9.1	Opening a D2PC Case	9-1
9.2	Saving a D2PC Case.....	9-2
9.3	Deleting a D2PC Case	9-3
9.4	Archiving D2PC Cases.....	9-4
9.4.1	Using the archive_d2.sh Script.....	9-4
9.4.2	Archiving D2PC by Date	9-5
9.4.3	Archiving D2PC by Number of Cases	9-6
9.4.4	Running D2PC Archiving from the Command Line	9-6
9.4.5	Archiving Limitations	9-8
9.5	Importing a D2PC Case.....	9-8
	Appendix A – Site Survey Form	A-1
	Appendix B – FEMIS Database Changes	B-1
	Appendix C –Database Data Models.....	C-1
	Appendix D –FEMIS Data Dictionary	D-1

Tables

1.1	Types of Relational Data and General Use Description.....	1-2
1.2	Integrated COTS Software Products.....	1-4
3.1	CSEPP Global Preset FEMIS Tables.....	3-5
3.2	Global Preset Database Tables.....	3-6
3.3	Site-Specific and EOC-Specific FEMIS Tables.....	3-8
3.4	Site-Specific and EOC-Specific Preset Database Tables.....	3-9
3.5	Spatial Data Theme Descriptions.....	3-12
4.1	Site-wide View Tables.....	4-10
7.1	METTOWER.DAT File Example.....	7-2

Figures

1.1	Conceptual View of FEMIS.....	1-2
3.1	General Process of Data Preparation at a High Level.....	3-2
4.1	FEMIS Database Manager Window.....	4-2
4.2	Data Control on the FEMIS Database Manager Window.....	4-3
4.3	DBGrid Control on the FEMIS Database Manager Window.....	4-4
6.1	Select CSEPP Mode Window.....	6-1
6.2	Select Exercise Window.....	6-2
6.3	Exercise Setup Window.....	6-2
6.4	Exercise Setup: Create Exercise Window.....	6-3
6.5	Exercise Setup: Modify Exercise Window.....	6-4
8.1	Evacuation Case Window.....	8-1
8.2	Open Evacuation Case Window.....	8-2
8.3	Save Evacuation Case As Window.....	8-3
8.4	Delete Evacuation Case Window.....	8-3
8.5	Import Case Window.....	8-5
9.1	D2PC Interface Window.....	9-1
9.2	Open D2PC Case Window.....	9-2
9.3	Save D2PC Case As Window.....	9-3
9.4	Delete D2PC Case(s) Window.....	9-3
9.5	Import D2PC Window.....	9-8

Acronyms and Definitions

AAT	Arc attribute table
APR	ArcView Project file
CFCC	Census Feature Class Code
CLA	Chemical Limited Area
COTS	Commercial-Off-The-Shelf
CSEPP	Chemical Stockpile Emergency Preparedness Program
D2PC	Chemical wind dispersion model used in FEMIS
DBMS	Database management system
DEI	Data Exchange Interface
DLG	Digital Line Graph
E-mail	Electronic mail
EMIS	Emergency Management Information System
EOC	Emergency Operations Center
EPZ	Emergency Planning Zones
ESIM	Evacuation SIMulation, part of Oak Ridge Evacuation Modeling System (OREMS)
FEMIS	Federal Emergency Management Information System
FIPS Code	Federal Information Processing Systems Code
GIS	Geographic Information System
IBS	Integrated Baseline System
IDYNEV	Interactive DYNAMIC EVacuation
IEM	Innovative Emergency Management, Inc.
LAN	Local Area Network
MCE	Maximum Credible Event
Met	Meteorological
OREMS	Oak Ridge Evacuation Modeling System
ORNL	Oak Ridge National Laboratory
PAD	Protective Action Decision
PAR	Protective Action Response
PAT	Point/polygon attribute table
PC	Personal computer
PNNL	Pacific Northwest National Laboratory
RDBMS	Relational database management system
SBCCOM	U.S. Army Soldier and Biological Chemical Command
SQL	Structured Query Language
SQL script	Sequence of SQL statements that performs database operations
TCP	Traffic Control Point
UNIX	Generic name for the Server Operating System
USGS	United States Geological Survey

1.0 Overview

The Federal Emergency Management Information System (FEMIS[®])^(a) information resources are described in this *FEMIS Data Management Guide*. To comprehend what types of data are present, where the data is located, and how it is managed during the life span of the system, a basic understanding of the FEMIS architecture is necessary. The system is being developed by Pacific Northwest National Laboratory (PNNL)^(b) and was initially designed for a single Chemical Stockpile Emergency Preparedness Program (CSEPP) site that has multiple Emergency Operations Centers (EOCs). FEMIS has been expanded to provide for other hazards, such as floods to allow EOCs to use the system for non-CSEPP emergencies. The capability to connect to remote CSEPP sites and share information will be present in a future release.

Each EOC has personal computers (PCs) that emergency planners and operations personnel use to do their jobs. These PCs are connected via a local area network (LAN) to servers that provide efficient EOC-wide services. Each EOC is interconnected to other EOCs via telecommunications links.

FEMIS is a client/server system where much of the application software is located in the client PC. This client software consists of the FEMIS application, government furnished dispersion and evacuation models, and Commercial-Off-The-Shelf (COTS) software tools, such as the ArcView geographic information system (GIS) and Microsoft Project (electronic planning).

A UNIX server provides data management services, ARC/INFO GIS capabilities, evacuation (Evac) modeling, electronic mail (E-mail), and meteorological (Met) input processing. A PC communication utility is available to interface with external subsystems.

Figure 1.1 illustrates a conceptual view of FEMIS and the types of information required. Much of this information is located in the Oracle database management system (DBMS). Between EOCs, the DBMSs cooperate to share data, which allows multiple PC users to share the information while maintaining the integrity and persistence of the data. The user then adds information, makes decisions, displays maps, or uses other FEMIS functionality. Decisions and/or information are passed back to the FEMIS database and notifications are made to the FEMIS users. Other information exists on the UNIX file system and the Met server. The COTS tool information for the GIS, project management, and E-mail are present on the client file system. Table 1.1 summarizes the types of relational data used by FEMIS and the general use of that data.

Note: See the *FEMIS Installation Guide* for assistance with creating the database and installing the Oracle server as well as relational database management system (RDBMS). For assistance with validation and troubleshooting, see the *FEMIS System Administration Guide*.

(a) FEMIS software was copyrighted in 1995 by Battelle Memorial Institute.

(b) Pacific Northwest National Laboratory is operated for the U.S. Department of Energy by Battelle Memorial Institute under Contract DE-AC06-76RLO 1830.

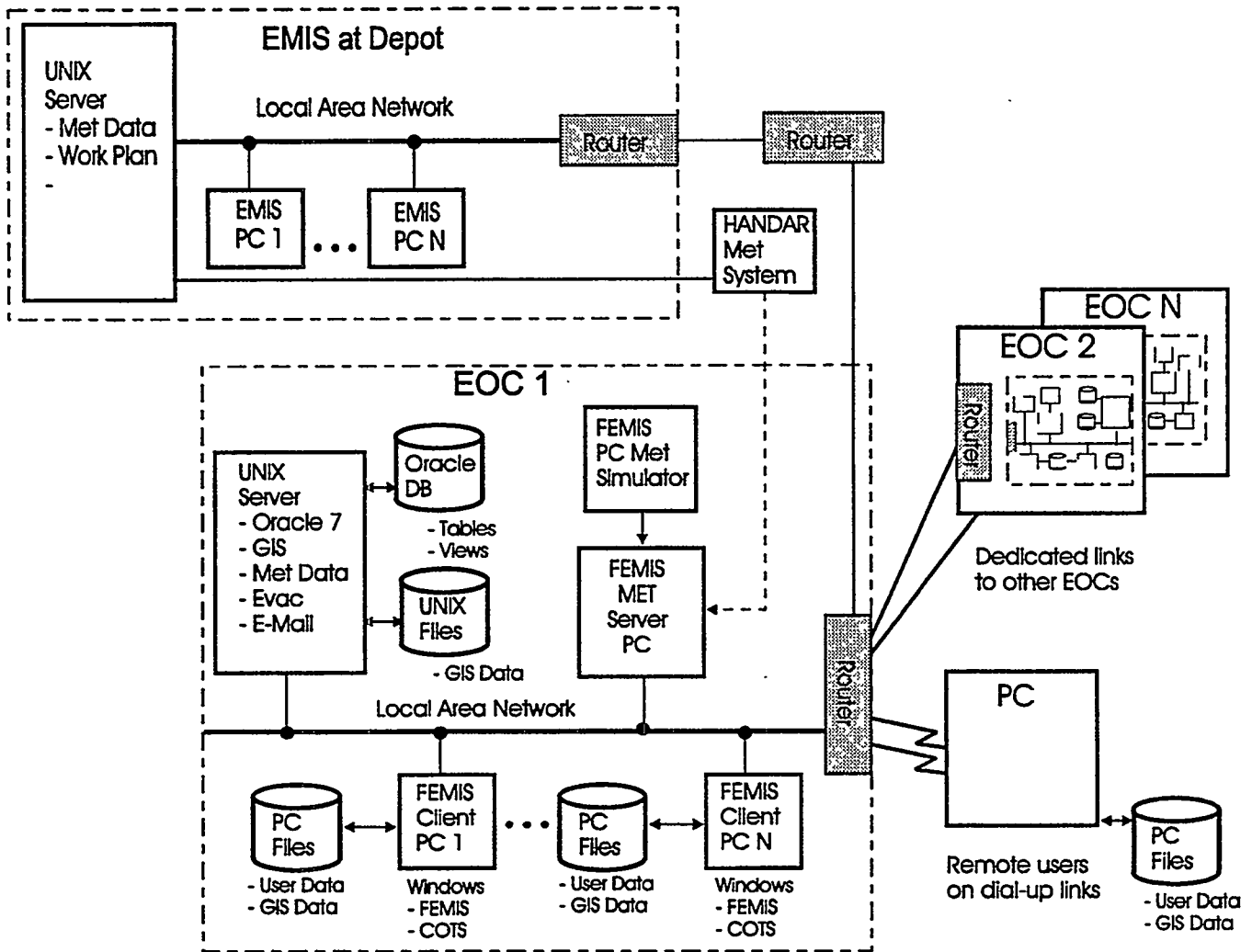

Figure 1.1. Conceptual View of FEMIS

Table 1.1. Types of Relational Data and General Use Description

Data Type	Data Use Description
D2PC Data	Relational data tables used by the dispersion model
Electronic Plan Data	Supporting electronic planning information
Evacuation Data	Relational data tables used by the ESIM ^(a) Evacuation Model
Facility Data	Facilities, resources, and shelters information
Hazard Data	Supporting multi-hazard planning and operations use
Met Data	Weather conditions and tower information
Personnel Data	Person and organization information and user control data
Population Data	Population information including special populations
Resource Data	Resources and Memoranda of Understanding information

Data Type	Data Use Description
Risk Data	Plumes, wedges, threatened areas, and Protective Action Decision (PAD)/Protective Action Responses (PARs) information
Site Data	CSEPP site information including EOC data
Source Data	Chemical agents, munitions, bunkers, events, and casualties
Spatial Data	Relational data supporting the GIS
Work Plan Data	Work Plans, Maximum Credible Event (MCE) data, the journal, and D2PC/Evacuation case management data
Zone Data	Information about emergency planning zones
(a) Evacuation SIMulation (ESIM) model is part of the Oak Ridge Evacuation Modeling System (OREMS).	

1.1 Point of Contact

We encourage you to contact us with suggestions or to ask questions. You can contact us by mail, telephone, fax, or E-mail:

Pacific Northwest National Laboratory
Ranata L. Johnson
P.O. Box 999, MS K7-28
Richland, WA 99352
Telephone: (509) 375-6311
Fax Number: (509) 375-3641
E-mail address: ranata.johnson@pnl.gov

1.2 Document Organization

This document is organized into nine sections and four appendices that contain supporting information.

Section 1.0 – Overview – contains an overview for managing the FEMIS data.

Section 2.0 – Resource Documents – lists documents referenced or used as resources for this document.

Section 3.0 – Building the Initial Information – describes how the initial information is compiled and how the relational data and spatial data are initially loaded.

Section 4.0 – Managing Relational Data – discusses how relational data is managed during system operation.

Section 5.0 – Managing Spatial Data – describes how the spatial data is managed after it is installed.

- Section 6.0 – Managing Exercise Data – discusses how exercise data is managed.
- Section 7.0 – Managing Meteorological (Met) Data – discusses how the real-time meteorological data is managed.
- Section 8.0 – Managing Evacuation (Evac) Data – describes managing the evacuation data model. Subsections describe opening, saving, deleting, and importing a case.
- Section 9.0 – Managing D2PC Model Data – discusses how the D2PC model data is managed. Subsections describe opening, saving, deleting, and importing a case.
- Appendix A – Site Survey Form – consists of a Site Survey form example. The site specific survey is used to collect an essential set of site parameters needed to preset the site database.
- Appendix B – FEMIS Database Changes – consists of the Oracle database schema and GIS changes that have been implemented for FEMIS v1.4.6.
- Appendix C – Database Data Models – consists of the FEMIS main data model and the data model for LOCATION_TYPE tables.
- Appendix D – FEMIS Data Dictionary – consists of the FEMIS data dictionary, which is a dynamic listing of the current database.

1.3 Software Products

FEMIS integrates the following COTS software products.

Table 1.2. Integrated COTS Software Products

Software Application	Software Company
ArcView GIS	Environmental Systems Research Institute, Inc. (ESRI)
NFS Maestro	Hummingbird Communications Ltd.
Solaris and Solstice NFS Client	Sun Microsystems, Inc.
Microsoft Windows NT Workstation	Microsoft Corporation
Microsoft Project for Windows	Microsoft Corporation
Oracle	Oracle Corporation
SQL*Net, TCP/IP Adapter, and ODBC Driver	Oracle Corporation

FEMIS integrates the following government-furnished software products.

D2PC (January 1999)	U.S. Army Soldier and Biological Chemical Command (SBCCOM)
PARDOS v3.1 (May 1997)	U.S. Army SBCCOM
Evacuation SIMulation Model (ESIM v2.1f13)	Oak Ridge National Laboratory

The following software products are optional.

ARC/INFO	Environmental Systems Research Institute, Inc.
Corel WordPerfect	Corel Corporation
Microsoft Office	Microsoft Corporation

2.0 Resource Documents

FEMIS Installation Guide – This document provides instructions for installing and configuring the FEMIS software package.

FEMIS System Administration Guide – This document contains a detailed description of the system administration interface.

Integrated Baseline System (IBS) Data Management Guide, Version 2.1 – This document contains a full description of the data files present in the IBS system.

3.0 Building the Initial Information

After FEMIS is installed, information is present in the database to enable the immediate use of the system. For example, the database tables used for validation are preset with the correct values, base maps are present in the spatial data, and some facility data is present. This section describes how this initial information is obtained and loaded into the system as part of the installation.

The initial information can be grouped into the following three classes:

- **CSEPP global** – EOCs at all sites will contain identical information for this class of tables. Examples are the relational tables named `State` and `Hazard_Site`. This data is available from PNNL for new installations.
- **Site global** – All EOCs at a given site will contain identical information for this class of tables. Examples are the relational tables named `Zone` and `Accident_Class`. This data is obtained from existing sources in electronic form or manually entered.
- **EOC specific** – Each EOC at the site will have distinct information for this class of tables. Examples are the relational tables named `Facility` and `Memo_Understanding`. Like the site global data, some of this information is available in electronic form and some will be gathered and entered manually.

The latter two classes of data prepared for a site have to be tailored to conditions present at that site. Factors to consider are the number and type of EOCs present, the objectives of the site, and the area of interest for map and GIS theme coverage. Another consideration is the amount of information contained in active Emergency Management Information System (EMIS) and Integrated Baseline System (IBS) databases that can be extracted for the new FEMIS system.

Figure 3.1 illustrates the general process of data preparation at a high level. The detailed steps to accomplish this are described in the following paragraphs.

EMIS is currently being used by the U.S. Army as the onpost automation system at most CSEPP sites. EMIS has a centralized database using the Oracle DBMS, and it also has a GIS that is used somewhat in the same manner as ArcView GIS is used in FEMIS. Therefore, EMIS is a source for onpost relational data (such as igloos) and spatial information (such as base maps tailored to the site environment).

IBS is used at some CSEPP sites for offpost EOC automation at the county and state levels. The IBS EOCs tend to operate autonomously so each contains information that is unique. The data contained in IBS is in ASCII files and binary files for the spatial information. In general, data must be extracted from each IBS system deployed at the site. Then parts of this data have to be merged to ensure that common information is consistent. IBS is a source for offpost facility, personnel, and resource information.

The FEMIS database includes some types of data not present in IBS and EMIS. This type of information is obtained during the Site Survey. Also, the Site Survey is used to validate some of the data captured from IBS and EMIS; more details are provided in Section 3.1, Site Survey.

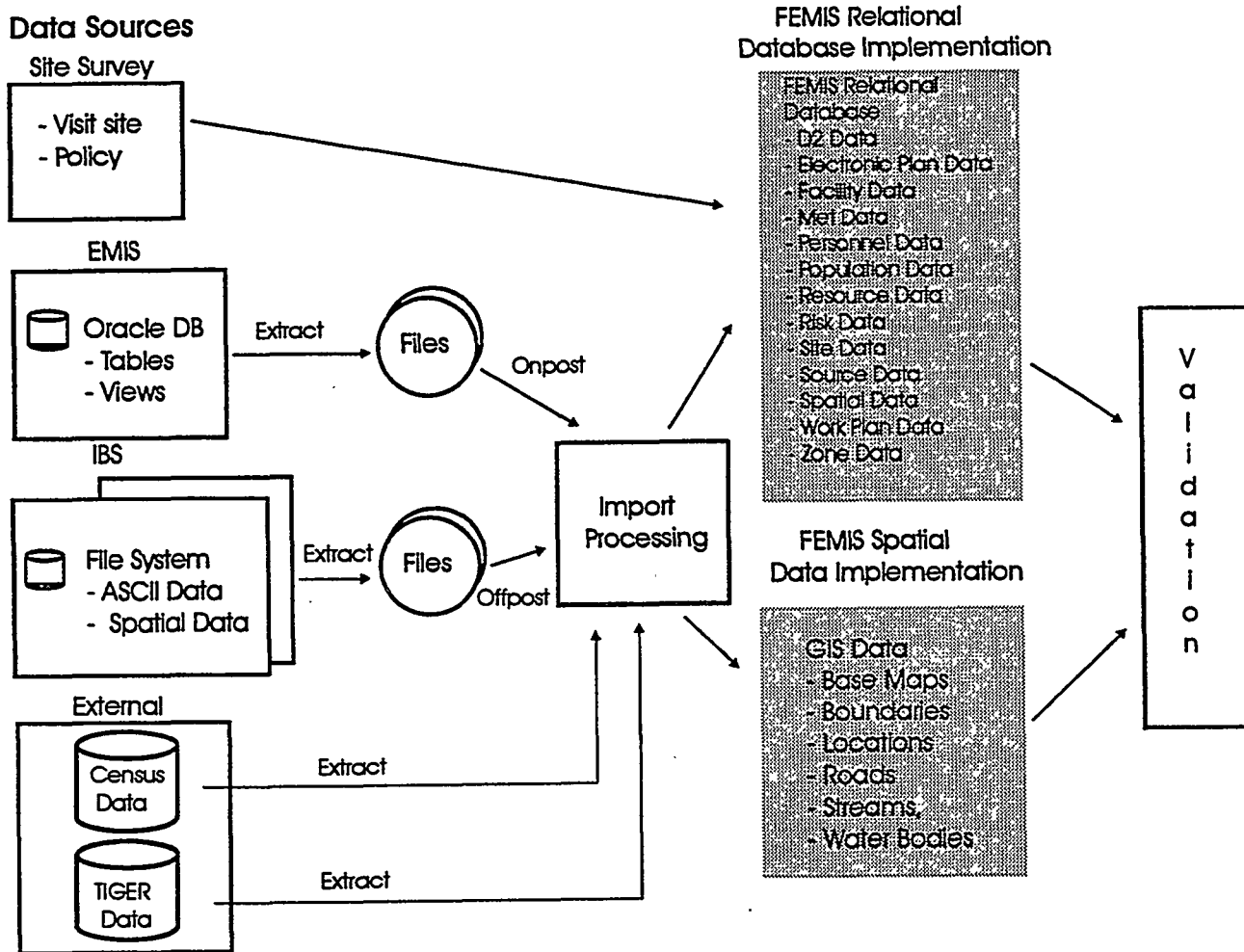

Figure 3.1. General Process of Data Preparation at a High Level

The extraction and post processing required for relational and spatial data are discussed in Sections 3.2, Building Relational Data and 3.3, Building Spatial Data. In general, each relational table or spatial data file requires individualized processing.

Census data and TIGER/Line data provided by the government are important external data sources. As shown in Figure 3.1, subsets of information from these sources are extracted and used for both spatial and relational databases. Section 3.3, Building Spatial Data, discusses how this is accomplished.

The validation step shown in Figure 3.1 is very important. It is accomplished after the spatial and relational databases are created. Even though some validation is done during the import processing, the final validation is needed to ensure consistency between the inter-related tables and files that comprise the FEMIS database.

3.1 Site Survey

Although much of the information needed to preset the FEMIS database is available in electronic format, some information is not. Therefore, a means to collect a varied set of parameters that are not available in IBS, EMIS, or the government-furnished external sources is needed. All sites will require a common set of parameters obtained from the Site Survey. Depending on how widely IBS and EMIS are used at a given site, additional information may be required.

The Site Survey provides default and recommended values in many cases. The EOC personnel should review the data provided and modify it directly on the form. The electronic Site Survey form uses a computer spreadsheet for capturing extensive amounts of data.

An example of a Site Survey is included in Appendix A to indicate the basic information that is needed for FEMIS. Electronic copies of the survey form will be sent to each EOC site for completion. When completed, the survey is returned to the development location for analysis of compatibility with other information. An onsite follow up meeting is held at each EOC to resolve questions and ensure consensus at the site.

3.2 Building Relational Data

The relational database in FEMIS is managed by Oracle7, a commercial DBMS. The distributed processing features of Oracle are utilized to produce a multi-server distributed data architecture. Data replication is widely used to provide a local copy of most shared tables. This replication is important because it allows an EOC to operate autonomously in case the links to other EOCs are not operational. Also, performance is enhanced because the shared tables are located on the local database.

The FEMIS relational database is comprised of approximately 180 tables. The FEMIS logical data model describes graphically what information is present and how the data objects are interrelated. This model represents a large collection of general purpose tables, such as evacuation data and GIS and dispersion tables. Appendix B, FEMIS Data Schema Changes, provides the database schema changes that have been implemented to update the database from FEMIS v1.4.5 to the current version, FEMIS v1.4.6. A diagram of the FEMIS model is included in Appendix C, Database Data Model. Definitions of the database attributes can be found in Appendix D, FEMIS Data Dictionary.

Based on design efforts and testing results, each relational database table is either local to an EOC or shared with the other EOCs. Data in the local tables can be accessed only from users logged in to that EOC database. The data in shared tables is available to users at all EOCs. Details of data placement are made transparent to the FEMIS users, so the FEMIS database appears to be a single, unified collection of tables. This physical design of the Oracle database is provided as a part of database implementation and can be tailored to CSEPP sites. Instructions about site tailoring are discussed in Section 2.3.4, Defining the Database Topology, in the *FEMIS Installation Guide*.

Approximately one-half of the tables do not contain any information when the system is installed. These are tables, such as the Situation Summary table, that will contain information about the current conditions at the site. As the system is used, data will accumulate in these tables and become a useful resource. The management of these tables will be discussed in Section 4.0, *Managing Relational Data*.

The remaining tables are preset with data as part of the system installation process. Over the life-cycle of FEMIS, some of the data in this class of tables may require updates after installation, which are discussed in Section 4.0, *Managing Relational Data*. How preset data is collected and processed to become part of the delivered database is the subject of the remainder of this section.

Tables containing preset information that is universal to all sites are called CSEPP Global tables. During FEMIS development, information was assembled from various sources and loaded into this class of tables. Table 3.1 lists the Oracle tables that are in this class, what type of user interface manages the data in the table (all of these tables are managed by the FEMIS Data Manager), and comments.

Table 3.2. illustrates the source of the information for the CSEPP Global tables, the filename (if appropriate), the loading strategy, and the contents of the information in the table. A PNNL source means that the information was assembled from various sources available to PNNL.

The other two table classes with preset information contain site-specific and EOC- specific data. Table 3.3 lists the tables in these two classes (similar to Table 3.1) illustrating the table name, what type of user interface manages the data in the table, and comments. More complete details for gathering and loading these tables are provided in Table 3.4.

3.3 Building Spatial Data

FEMIS spatial data contains location information in the form of geographic coordinates of points, lines, and polygons that represent physical features and non-physical area boundaries on the surface of the earth. Within FEMIS, this location information is stored as ArcView GIS themes which are accessed by the FEMIS application via the ArcView GIS software. Each theme represents a coherent set of similar geographic features (e.g., roads, facility locations, census tract boundaries). FEMIS spatial data also contains attribute information that is associated with the geographic features that make up the themes. These attribute values are stored and maintained in the FEMIS relational database. They are attached to the features within the ArcView GIS themes as required by the FEMIS applications.

Figure 3.1 shows the general approach to building the initial FEMIS spatial and relational databases. Data from various information sources must be processed by the appropriate FEMIS data import software programs to extract the required data elements and place them into the proper data structures for storage in the FEMIS relational and spatial databases. All required attributes associated with both geographic and non-geographic data objects are stored in the FEMIS relational database. The geographic coordinates of the spatial features, together with selected attributes of those features, are stored as ArcView GIS themes in the FEMIS spatial database.

Table 3.1. CSEPP Global Preset FEMIS Tables

Table #	Table Name	User Interface	Comments
1	ACCIDENT_CLASS	DataMgr	
2	ACTIVITY	DataMgr	
3	AGENT_MUNITION	DataMgr	
4	CHEMICAL_AGENT	DataMgr	
5	CONTROL_POINT	DataMgr	Initial
6	DOSAGE	DataMgr	
7	EP_ERROR_CODES	DataMgr	
8	FACILITY_TYPE	DataMgr	
9	GOAL	DataMgr	
10	HAZARD_SITE	DataMgr	
11	LOCATION_TYPE	DataMgr	
12	MEASUREMENT_DEFN	DataMgr	
13	MEASUREMENT_TYPE	DataMgr	
14	MET_PARAMETER	DataMgr	
15	MUNITION	DataMgr	
16	OBJECT_SUBTYPE	DataMgr	
17	PD_LEVEL	DataMgr	
18	PLAN_DETAIL	DataMgr	Template
19	PLAN_HEADER	DataMgr	Template
20	PRIVILEGE	DataMgr	
21	PROTECTIVE_ACTION	DataMgr	
22	SHELTER_DEFINITION	DataMgr	
23	STATE	DataMgr	
24	SYSTEM_MODE	DataMgr	
25	SYSTEM_PHASE	DataMgr	
26	SYSTEM_STAGE	DataMgr	
27	VAL_LIST	DataMgr	
28	VAL_LIST_DATA	DataMgr	
29	VAL_LOCATION_TYPE	DataMgr	
30	ZONE_TYPE	DataMgr	For CSEPP zones only

Table 3.2. Global Preset Database Tables

Table Loaded	Source	Filename	Load Strategy	Contents
ACCIDENT_CLASS	PNNL	None	SQL load using data acquired during development	Global validation for accident classes and descriptions
ACTIVITY	PNNL	None	SQL load using data acquired during development	Global validation for activity codes and descriptions
AGENT_MUNITION	EMIS	AGENT_MN.DAT	SQL load using EMIS data	Global agents, munitions and quantities per munition
CHEMICAL_AGENT	PNNL	None	SQL load using data acquired during development	Global agent codes and types
CONTROL_POINT	PNNL	None	SQL load using software control points	Global control point names and descriptions
DOSAGE	PNNL	None	SQL load using normal D2PC dosages	Dosage levels and descriptions from D2PC model
EP_ERROR_CODES	PNNL	ERROR.DAT	SQL load ESIM user manual error codes	Error code with description of error for EVAC
FACILITY_TYPE	PNNL/ IBS	FACIL.DAT	SQL load from both the PNNL data and the Facility_Type field within the facility data file	Global facility types and their descriptions
GOAL	PNNL	None	SQL load with data based on user advisory board	"Save lives, protect property"
HAZARD_SITE	PNNL	None	SQL load using data acquired during development	Compilation of the names, locations, and description for the CSEPP sites
LOCATION_TYPE	IBS	LOC_TYPE.DAT	SQL load with control data file. To generate the control file, the original data file from IBS must be edited to remove unrelated data.	Global validation for location types and descriptions
MEASUREMENT_DEFN	PNNL	None	SQL load using data acquired during development	Global validation for measurement classes
MEASUREMENT_TYPE	PNNL	None	SQL load using data acquired during development	Global validation for measurement types and description
MET_PARAMETER	PNNL	None	SQL load using data acquired during development	Global validation for parameter codes and descriptions
MUNITION	PNNL	None	SQL load using normal D2PC munitions	Global munitions and descriptions
OBJECT_SUBTYPE	PNNL/ IBS	FACIL.BAT	SQL load from both PNNL control data and the Facility_Type field within the facility data file	Global validation for location types and FEMIS object subtypes
PD_LEVEL	PNNL	None	SQL load using data acquired during development	Plan level name and number
PLAN_DETAIL	PNNL	None	SQL load using data acquired during development	Plan reference ID, responsible parties, start, finish, and duration times for plan template
PLAN_HEADER	PNNL	None	SQL load with plan data template	Plan reference ID, name, status, descriptions for initial plan template

Table Loaded	Source	Filename	Load Strategy	Contents
PRIVILEGE	PNNL	None	SQL Plus query based on CONTROL_POINT table	Global privilege numbers and flags for assigned privileges based on control points
PROTECTIVE_ACTION	PNNL	None	SQL load using data acquired during development	Global validation for protective actions and descriptions
SHELTER_DEFINITION	PNNL	None	SQL load using data acquired during development	Global validation for shelter types and descriptions
STATE	PNNL	None	SQL load using data acquired during development	Global validation for state codes and names
SYSTEM_MODE	PNNL	None	SQL load using data based on user advisory board	Global system modes, default flags and description
SYSTEM_PHASE	PNNL	None	SQL load using data based on user advisory board	Global phase names, flags and descriptions
SYSTEM_STAGE	PNNL	None	SQL load using data based on user advisory board	Modes, phases, and stages
VAL_LIST	PNNL	None	SQL load using data acquired during development	Validation lists names and descriptions for Visual Basic applications
VAL_LIST_DATA	PNNL	None	SQL load using data acquired during development	Validation lists data and text
VAL_LOCATION_TYPE	PNNL	None	SQL load using data acquired during development	Global validation table for location types
ZONE_TYPE	PNNL	None	SQL load using data acquired during development	Global validation for CSEPP zones and descriptions

3.3.1 Data Sources and Import Processing

The five major sources of FEMIS spatial data are discussed below:

1. **EMIS (Emergency Management Information System).** EMIS was developed for the U.S. Army as an interim onpost emergency management system. EMIS stores and manages spatial data and related attributes for onpost geographic features, model results, and raster image background maps. The attribute information is stored in Oracle relational database tables or ASCII text files.
2. **IBS (Integrated Baseline System).** IBS was developed as an interim offpost emergency management system. IBS stores and manages spatial data and related attributes for offpost geographic features and model results. The information is stored in a file system developed specifically for IBS. Most of the data is available in the form of ASCII files.

Table 3.3. Site-Specific and EOC-Specific FEMIS Tables

Table #	Table Name	User Interface	Comments
1	AGENCY	Agency UI	
2	BUNKER	GIS	Read only
3	CENSUS_BLOCK	DataMgr	Read only
4	CENSUS_SUBDIVISION	DataMgr	Read only
5	CENSUS_TRACT	DataMgr	Read only
6	COUNTY	DataMgr	
7	DEPARTMENT	Department UI	
8	EMERGENCY_SUPPORT	DataMgr	
9	EOC	DataMgr	
10	EOC_OBJECTIVE	DataMgr	
11	EOC_ZONE	DataMgr	For CESPP zones only
12	FACILITY	Facility UI	
13	FEMIS_USER	Manage User UI	
14	GEO_OBJECT	DataMgr	Data captured with GIS load, export
15	GIS_LAYER	DataMgr	Data captured with GIS load
16	GIS_LAYER_DEFINITION	DataMgr	
17	MET_TOWER	DataMgr	Compatibility to Met towers onsite
18	NAME_SUBSTITUTION	DataMgr	
19	PA_UNIT	DataMgr	
20	PERSON	Person Form UI	
21	POSITION	DataMgr	
22	POSITION_ASSIGNMENT	DataMgr	
23	RESOURCE_CATEGORY	DataMgr	
24	RESOURCE_DEFINITION	Resource Definition UI	
25	RESOURCE_LOCATION	Facility UI	
26	RESOURCE_OWNER	Facility UI	
27	STORED_AGENT	DataMgr	
28	USER_MODE_PRIV	DataMgr	
29	VAL_POSITION	DataMgr	
30	WK_POSITION	DataMgr	
31	ZONE	DataMgr	For CSEPP zones only
32	ZONE_IN_GROUP	DataMgr	For CSEPP zones only
33	ZONE_RISK_GROUP	DataMgr	For CSEPP zones only

Table 3.4. Site-Specific and EOC-Specific Preset Database Tables

Table Loaded	Source	Filename	Load Strategy	Contents
AGENCY	IBS	AGENCY_LOOKUP.DAT	SQL load with validated data	Agency codes and their associated agency names
BUNKER	EMIS	GISIGL.DAT (onpost)	SQL load with validated data	Igloo names and codes specific to the site
CENSUS_BLOCK	Census	STF1B tape files	SQL load with census data	State and county FIPS codes and block name
CENSUS_SUBDIVISION	Census	STF1B tape files	SQL load with census data	State and county FIPS codes and subdivision name
CENSUS_TRACT	Census	STF1B tape files	SQL load with census data	State and county FIPS codes and tract name
COUNTY	PNNL	None	SQL load with preset data. Use Site Survey results if different	State and county FIPS codes and county name
DEPARTMENT	PNNL and Site Survey	None	SQL load with Dept_Code set to Agency_Code or Site Survey	Department and agency codes. IBS does not have department code so this is generated.
EMERGENCY_SUPPORT	IBS and Site Survey	EF.DAT	SQL load with preset data. Use Site Survey results if different	Emergency support functions and descriptions
EOC	IBS and Site Survey	None	SQL load with preset data. Use Site Survey results if different.	EOC names, types number, description
EOC_OBJECTIVE	Site Survey	None	SQL load with data from Site Survey	EOC name, notify, decision and goal times, description and dose levels
EOC_ZONE	PNNL	None	Preloaded list of zones associated with an EOC. Use Site Survey results if different.	EOC and zone names
FACILITY	IBS and Site Survey	FACIL.DAT	See Facility Note	Facility names, capacity, description
FEMIS_USER	Site Survey	None	SQL load with data from Site Survey	User code with encrypted password, account status
GEO_OBJECT	PNNL	None	SQL load with preset data	Data for all spatial objects
GIS_LAYER	PNNL	None	SQL load with preset data	Data for existing themes
GIS_LAYER_DEFINITION	PNNL	None	SQL load with preset data	Data for defining themes
MET_TOWER	Site Survey	METTOWER.DAT	SQL load with data from the Site Survey	Names and locations of Met towers
NAME_SUBSTITUTION	PNNL	None	SQL load with preset data	Standard case naming
PA_UNIT	Site Survey	None	SQL Plus query based on zone and facility tables	Protective action units, type and zone or facility name
PERSON	IBS	PERSON.DAT	See Person Note	Person reference number, name, address
POSITION	Site Survey	None	SQL load with data from Site Survey	Position code with address, phone and description

Table Loaded	Source	Filename	Load Strategy	Contents
POSITION_ASSIGNMENT	Site Survey	None	SQL load with data from Site Survey	Persons who are users
RESOURCE_CATEGORY	Site Survey	RESOURCE.DAT	SQL load with data from Site Survey	The category and its description
RESOURCE_DEFINITION	Site Survey	RESOURCE.DAT	SQL load with data from Site Survey	Resource reference number, name, description
RESOURCE_LOCATION	Site Survey	None	SQL Plus query based on RESOURCE_FACILITY table	Location of the resource at the facility
RESOURCE_OWNER	Site Survey	None	SQL load with data from Site Survey	Agency that controls the resource.
STORED_AGENT	EMIS	GISIGL.DAT	SQL load with validated data	Bunker name, agent code and munition type
USER_MODE_PRIV	Site Survey	None	SQL Plus query based on tables PERSON, PRIVILEGE and SYSTEM_MODE	Control point names, privilege numbers, user codes, and mode names
VAL_POSITION	Site Survey	VAL_POS.DAT	SQL load with preset data. Use Site Survey results if different	Position codes and names
WK_POSITION	Site Survey	POSITION_LOOKUP.DAT	SQL load with validated data	Agency, department, and title of position
ZONE	IBS	Spatial data files	SQL load with validated data	Zone name and type
ZONE_IN_GROUP	Site Survey	None	SQL load with data from Site Survey	List of zones in risk groups
ZONE_RISK_GROUP	Site Survey	None	SQL load with data from Site Survey	Name of risk groups
<p>A temporary table, T_FACILITY is created, loaded and updated with the data in FACIL.DAT. The data load is completed when the data is copied from the T_FACILITY table to the facility table. Updates from the Site Survey will be included.</p> <p>Since the GEO_OBJECT table data represents geographical coordinates for many objects represented in the relational portions of the database, it has several different SQL Loader control scripts which load data into the table. Examples include the facilities from each EOC, igloos, zones, and counties.</p> <p>Person Note: Two temporary tables, T_PERSON and T_AGENCY are created, loaded and updated with the data from PERSON.DAT. The data load is completed when the data is copied from the T_PERSON table to the person table. Updates from the Site Survey will be included.</p>				

3. **TIGER/Line Data.** The U.S. Bureau of the Census provides TIGER/Line data files that contain detailed location and attribute information for a variety of physical and non-physical features such as roads, railroads, streams and water bodies, facilities, landmarks, state and county boundaries, census unit boundaries, and other political and administrative boundaries. These ASCII files are organized into 12 record types at the county level (or equivalent to the county level for all states in the United States). Import processing of TIGER/Line data is discussed in detail in Section 3.3.2, TIGER/Line Data.
4. **1990 Census Statistical Data.** The U.S. Bureau of the Census provides statistical census data files that contain demographic information from the 1990 decennial census. This data consists of large ASCII files, which contain population, family, and household counts within various demographic

groupings (i.e., by age, sex, race, household type, income, and other social and economic factors). The information is reported at several geographic levels (e.g., county, subdivision, census tract, block group, block). Selected portions of this data are required by FEMIS applications and must be extracted and attached as attributes to the corresponding TIGER/Line census area polygons.

5. **Site Configuration Data.** Some spatial data related to planning decisions made at the site (e.g., accident-based planning category boundaries) may not be available from EMIS or any other existing data system. This data must be obtained directly from site personnel and must be entered into ASCII files prior to FEMIS import processing.

The FEMIS spatial data themes are listed and characterized in Table 3.5. They can be divided into three categories as discussed below: static spatial datasets, user-modifiable spatial datasets, and model-related spatial datasets.

1. **Static spatial datasets** change infrequently and are managed and controlled by your Database Administrator. Users cannot modify the spatial information contained in these datasets. Examples of static spatial datasets are roads, census blocks, and emergency planning zone boundaries. All of these themes must be initially loaded into the FEMIS spatial database.
2. **User-modifiable spatial datasets** are the themes that can be created and/or modified by users from within certain FEMIS modules. User-modifiable themes include facilities, known points, traffic control points, sirens, and user-defined threat area wedges. The facilities theme is initially loaded with the locations of facilities that are known to be of interest for emergency planning purposes. Users can then add other facilities to this theme through the FEMIS Facility Management interface. The traffic control points theme is initially loaded with road and street intersections and other locations where it is expected that roadblocks or other traffic/access control mechanisms would be applied in an emergency. Users can then add other traffic control points through the FEMIS Known Points interface. The sirens theme is initially loaded with locational and attribute information on emergency warning sirens. Users can then add other siren locations through the FEMIS Known Points interface. Known points are other geographic point locations that users may wish to include as reference points for locating a hypothetical or real event, or for other purposes. Known points data optionally can be initially loaded into the FEMIS database. Users can then add other known points to this theme through the FEMIS Known Points interface. User-defined threat area wedges and D2PC plume-based wedges are not initially loaded into the FEMIS database. They are defined and generated through the FEMIS Threat Area interface.
3. **Model-related spatial datasets** are created by the hazard and evacuation model for each model case that is run. These themes are created and stored on the user's PC. Data on these model-related themes are also stored in the relational database to facilitate access by other users. These themes are generated entirely by the FEMIS software under the user's control and are thus not initially loaded.

The following sections briefly discuss typical data sources and import processing for each of the FEMIS spatial themes that must be initially loaded. Management of spatial data, after it has been initially loaded, is the responsibility of the site.

Table 3.5. Spatial Data Theme Descriptions

Generic Theme (Layer) Description	Data Source	User Directory	Filename	Data Type	User Modify	FEMIS Object ^(a)	Number of Themes
Facilities	IBS, FEMIS App	FACILITY	FACILITY	Vector - Point	Yes	Yes	1
Accident Based Planning Wedges	FEMIS App	WA_<eoc_code>	<eoc_code>_WA	Vector - Polygon	Yes	Yes	1 per EOC
D2 Plume (Dosage)	FEMIS App	D2_<eoc_code>	D<case_id(7)>	Vector - Polygon	Yes	Yes	1 per EOC and case
D2 Plume (Concentration)	FEMIS App	D2_<eoc_code>	K<case_id(7)>	Vector - Polygon	Yes	Yes	1 per EOC and case
D2 Wedge	FEMIS App	D2_<eoc_code>	W<case_id(7)>	Vector - Polygon	Yes	Yes	1 per EOC and case
Evacuation Centroids	FEMIS App	EV_<eoc_code> E<exercise_num>	C<case_id(7)>	Vector - Point	Yes	No	1 per EOC and case
Evacuation Links	FEMIS App	EV_<eoc_code> E<exercise_num>	L<case_id(7)>	Vector - Line	Yes	No	1 per EOC and case
Evacuation Nodes	FEMIS App	EV_<eoc_code> E<exercise_num>	N<case_id(7)>	Vector - Point	Yes	No	1 per EOC and case
Census Blocks	TIGER/Line	CEDBLOCK	<site_code>_TB ^(a)	Vector - Polygon	No	No	1
County Boundaries	TIGER/Line	STCOUNTY	<site_code>_SC	Vector - Polygon	No	Yes	1
Accident-Based Planning Categories	Site Configuration	ABPC	<site_code>_PC	Vector - Polygon	No	Yes	1
Igloos (point)	EMIS	IGLOO_P or CHEMSTOR	<site_code>_IP	Vector - Point	No	Yes	1
Emergency Planning Zones	IBS	ZONE	<site_code>_EZ	Vector - Polygon	No	Yes	1
Depot Zones	EMIS	ZONE	<site_code>_DEP	Vector - Polygon	No	No	1
Traffic Control Points	IBS, Site Survey	TCP	TCP	Vector - Point	Yes	Yes	1
Known Points	Various	KNOWN_P	KNOWN_P	Vector - Point	Yes	Yes	1
Met Towers	Site Configuration	METTOWER	<site_code>_MT	Vector - Point	No	Yes	1
Warning Sirens	IBS, Site Survey	SIREN	SIREN	Vector - Point	No	Yes	1
Administrative Boundaries	IBS	ADMINBND	<site_code>_AB	Vector - Polygon	No	No	1
Detailed Roads	TIGER/Line	ROADALL	<county_code>_RA	Vector - Line	No	No	1 per county
Major Roads	TIGER/Line	ROADMAJ	<site_code>_RM	Vector - Line	No	No	1
Railroads	TIGER/Line	RAILROAD	<site_code>_RR	Vector - Line	No	No	1
Streams, Water Bodies	TIGER/Line	STREAM	<site_code>_ST ^(a)	Vector - Line	No	No	1
Elevation Contours	IBS	CONTOUR	<site_code>c<interval(m)>	Vector - Line	No	No	1 per interval value
Image Maps	EMIS	IM <scale>	<site_code><scale><file>	Image	No	No	1 or more per scale

(a) "Yes" --> Contains entries in GEO_OBJECT table to link spatial and relational data.

3.3.1.1 Facilities

Facility locations and attributes are obtained from the IBS “known points” and “facility” ASCII files. An IBS export utility is used to create an ASCII file containing the facility names, locations, descriptions, and other attribute information. This file may be supplemented by information on additional facilities from the Site Survey or other sources. A loader script is used to load the data from this file into the relational database. An SQL script is then used to query the relational database and create an ASCII file containing facility locations and attributes in ArcView GIS Event Theme format. This file can be directly loaded as a point theme into ArcView GIS.

3.3.1.2 Accident Based Planning Wedges

Accident Based Planning Wedges (user-defined threat wedges) are generated within the Threat Analysis module of FEMIS and can be named and saved in the database for later use.

3.3.1.3 D2PC Plume Themes

D2PC Plume (Dosage and Concentration) themes and plume-based wedge themes are dynamic model-related themes generated within FEMIS. They are based on output from the D2PC model. D2PC cases may be imported from IBS or EMIS, or they may be created by running D2PC from within FEMIS.

3.3.1.4 Evacuation Themes

Evacuation themes (centroids, links, and nodes) are dynamic model-related themes generated in support of the Evacuation SIMulation (ESIM), part of the Oak Ridge Evacuation Modeling System (OREMS) model within FEMIS. There may be one set of evacuation theme files for every evacuation case in the system. Evacuation cases may be imported from IBS or OREMS, or they may be created from within FEMIS.

3.3.1.5 Census Blocks

The ARC/INFO® TIGERTOOL command (see Section 3.3.2, TIGER/Line Data) is used to convert TIGER/Line data files into ARC/INFO coverages for the counties surrounding the hazard site. Census enumeration district boundaries are then extracted from the ARC/INFO coverages, and separate coverages are created for census blocks. These coverages are then converted to ArcView GIS themes. Census tracts and subdivisions are not currently included as themes in the spatial database.

Census demographic data (e.g., population counts) are extracted from the STF-1B census statistical data files and stored in a text file as attributes of each census block, tract, or subdivision. These demographic attributes are then attached to an ArcView GIS census theme by running an Avenue script to join the demographic columns of the text file to the appropriate census theme’s attribute table.

3.3.1.6 County Boundaries

The ARC/INFO TIGERTOOL command is used to convert TIGER/Line data files into ARC/INFO coverages for the counties surrounding the hazard site. County boundary polygons are then extracted from the full TIGER/Line ARC/INFO coverages and stored in a new ARC/INFO coverage. This coverage is then converted to an ArcView GIS theme.

3.3.1.7 Accident-Based Planning Categories

For planning purposes, each CSEPP site determines the geographic boundaries of several categories of potential accidents. The categories represent different levels of impact severity and are typically represented geographically by concentric circles of differing radii centered on the site's Chemical Limited Area. Given the number of categories and the center and radius of each category's circle, the theme is generated by running an ArcView GIS/Avenue script using the appropriate input parameters for each circle.

3.3.1.8 Igloos (Point Locations)

Igloo locations and attribute data are obtained from EMIS or other sources. A script is used to extract the data from EMIS and create ASCII files containing the igloo names, locations, and contents (agents/munitions). A loader script is used to load the data from the ASCII file into the appropriate relational database tables. A second SQL script is then used to query the FEMIS relational database and create an ASCII file containing igloo locations and attributes in ArcView GIS Event Theme format. Some minor editing of this ASCII file may be needed to transfer multiple agent-munition data for an igloo from multiple records into a single record. This file can then be directly loaded as a point theme into ArcView GIS.

3.3.1.9 Emergency Planning Zones

Emergency planning zone boundary and attribute data are extracted from the IBS spatial data zone files into ASCII files. A loader script is used to load the zone data from the ASCII files into the appropriate relational database tables. Another ASCII file containing the zone coordinates in ARC/INFO Generate format is used to create an ARC/INFO polygonal coverage, which is then converted into the ArcView GIS zone theme.

3.3.1.10 Depot Zones

At a minimum, the Depot Zones theme will contain the Chemical Limited Area (CLA) boundary. For some CSEPP sites, the Depot Zones theme may also contain other on-post zones, sub-zones, or other designated non-overlapping areas within the depot boundary. The CLA and any other onpost zone boundary data to be included is obtained from EMIS text files, imported into an ARC/INFO coverage, and then converted to shape files which can be directly loaded into ArcView GIS.

3.3.1.11 Traffic Control Points

The locations of traffic control points are obtained from IBS (if available) or from site survey information. An IBS export utility or a text editor is used to create an ASCII file containing the traffic control point names, locations, descriptions, and other attribute information. A loader script is used to load the data from this file into the relational database. An SQL script is then used to query the relational database and create an ASCII file in ArcView GIS Event Theme format. This file contains the traffic control point locations and attribute information and can be directly loaded as a point theme into ArcView GIS.

3.3.1.12 Known Points

Known point locations normally are not initially loaded into a FEMIS database unless the site requests some special locations to be loaded as known points because they do not fit the data type of any of the other standard FEMIS point themes. Also, the ability is needed to modify these points dynamically from within FEMIS. If it is desired to load known points data into the database, a text file is created with the names, lat/lon locations, and other relevant information on the known points. A loader script is used to load the data from the text file into the relational database. An SQL script is then used to query the relational database and create a text file containing known point locations and attributes in ArcView GIS Event Theme format. This file can be directly loaded as a point theme into ArcView GIS.

3.3.1.13 Met Towers

Meteorological (Met) monitoring tower data is obtained from the Met subsystem's METTOWER.DAT file (see Section 7.0, Managing Meteorological [Met] Data). A loader script is used to load the data from the ASCII file into the appropriate relational database tables. An SQL script is then used to query the relational database and create an ASCII file containing Met tower locations and attributes in ArcView GIS Event Theme format. This file can be directly loaded as a point theme into ArcView GIS. The Met tower attribute table must also include properly named placeholder columns for the weather data variables that are transferred to the GIS at run time from the Met status board.

3.3.1.14 Warning Sirens

The locations of warning sirens are obtained from IBS (if available) or from site survey information. An IBS export utility or a text editor is used to create an ASCII file containing the siren names, locations, descriptions, and other attribute information. A loader script is used to load the data from this file into the relational database. An SQL script is then used to query the relational database and create an ASCII file in ArcView GIS Event Theme format. This file contains the siren locations and attribute information and can be directly loaded as a point theme into ArcView GIS.

3.3.1.15 Administrative Boundaries

Data on administrative boundaries (e.g., national forests, state parks, Native American reservations) are obtained from the IBS Administrative Boundaries data layer. An ASCII file containing the spatial

coordinates and attributes of Administrative Boundary polygons is exported from IBS, imported into ARC/INFO, and then converted into shape files for an ArcView GIS theme using ARC/INFO's ARCSHAPE command.

3.3.1.16 Road Themes (Detailed, Major)

The ARC/INFO TIGERTOOL command is used to convert TIGER/Line data files into ARC/INFO coverages for the counties surrounding the hazard site. Road features are then extracted from the full ARC/INFO coverages, and separate ARC/INFO coverages are created for detailed roads (one theme per county line segments with a Census Feature Class Code [CFCC] that begins with "A") and for major roads (CFCC beginning with "A1" or "A2") for this entire area. These coverages are then converted to ArcView GIS themes. Other CFCC road feature codes may optionally be included in the "major road" theme, depending on site preferences.

3.3.1.17 Railroads

The ARC/INFO TIGERTOOL command is used to convert TIGER/Line data files into ARC/INFO coverages for the counties surrounding the hazard site. Railroad features (CFCC beginning with "B") are then extracted from the full TIGER/Line ARC/INFO coverages and stored in a new ARC/INFO coverage. This coverage is then converted into an ArcView GIS theme.

3.3.1.18 Streams and Water Bodies

The ARC/INFO TIGERTOOL command is used to convert TIGER/Line data files into ARC/INFO coverages for the counties surrounding the hazard site. Stream and water body features (CFCC beginning with "H") are then extracted from the full TIGER/Line ARC/INFO coverages and stored in a new ARC/INFO coverage. This coverage is then converted to an ArcView GIS theme.

3.3.1.19 Elevation Contours

Elevation contour lines are normally obtained from IBS. An IBS import/export utility is used to generate an ASCII file in ARC/INFO Generate format for a line (arc) theme. The resulting file may need to be edited or regenerated to retain only the contour lines for the contour interval desired. Multiple files can be generated if multiple contour themes with different contour intervals are desired. Each ASCII file is used to generate an ARC/INFO line coverage, and the coverage is then converted into the shape files of an ArcView GIS theme.

3.3.1.20 Image Maps

Background image maps of the area surrounding the hazard site are obtained from the Sunraster format images used to create the EMIS background image library, or directly from USGS maps or other sources. Images at up to five different scales (1:24,000, 1:100,000, 1:250,000, 1:500,000, and 1:1 million) are incorporated into the FEMIS spatial database. The ARC/INFO GIS is used to register each image to

another FEMIS data layer, such as roads or streams. The image must then be converted to a Tagged Information File Format (TIFF) graphics file, integrated with other images of the same scale, and exported to ArcView GIS.

3.3.1.21 Other Themes

Other spatial data themes may be incorporated into a site-specific spatial database as required by the site. These themes may include (but are not limited to) interstate highways, interstate exits, populated places, place name boundaries, emergency route alerts, fire district boundaries, daytime population centroids, and nighttime population centroids. The procedures used to prepare and import these datasets into ArcView GIS varies depending upon the source and format of the original data.

3.3.2 TIGER/Line Data

The TIGER/Line files, available on a CD, contain coordinates of points, lines, and polygons that represent physical features (e.g., roads, streams and water bodies, landmarks) and non-physical boundaries (e.g., states and counties, 1990 census tracts and blocks, state parks). The files also contain attribute information (e.g., feature name, feature type, census unit identifier) associated with each point, line, and polygon feature. The attribute information can be used by the ARC/INFO GIS software to select individual features by name or to select a group of features by feature type (e.g., interstate highways). The TIGER/Line files also contain topological information (left and right area identifiers for a line segment) that allows ARC/INFO to construct polygons and to link the polygon areas to their associated arcs, label points, and area attributes. TIGER/Line files do not contain statistical census demographic data.

Each TIGER/Line dataset represents one county in a given state and may contain up to 12 different record (file) types. Some of the record types are optional, and thus not all county datasets have all 12 files. The format and content of these 12 file types are documented in the *Technical Documentation for TIGER/Line Census Files, 1990* (U.S. Department of Commerce, Bureau of the Census, Washington, D.C., 1991).

ARC/INFO provides two commands that can be used to convert TIGER/Line data to Arc coverages and associated Info attribute files. The TIGERARC command performs the basic conversion of point, line, and attribute data and completes the conversion rather quickly (usually 3 to 5 minutes). The TIGERTOOL command performs a comprehensive conversion using a macro supplied with ARC/INFO, version 6.0 and higher. TIGERTOOL runs TIGERARC and also builds the line and polygon coverages, relates those coverages to the Info files that contain the various attributes associated with the geographic objects, and checks for and reports detectable errors or inconsistencies in the data. TIGERTOOL takes approximately 15 to 20 minutes to complete for a typical county dataset.

The syntax for the TIGERTOOL command for use within FEMIS is as follows:

```
TIGERTOOL <tiger_line_file_prefix> <out_cover_prefix> VTD
```

Each TIGER/Line county dataset contains a set of files with names that are identical except for the last character in the filename. The second item in the command line, <tiger_line_file_prefix>, should be set to this common part of the filename. The last character appended to the common filename indicates the file type. The 12 file types are described via an example dataset in the following paragraphs. Similarly, <out_cover_prefix> is the filename prefix to be used to identify the output coverages to be created by TIGERTOOL. The VTD option instructs TIGERTOOL to extract and store the Voting Tabulation District boundaries.

The set of TIGER/Line files for Gilliam County, Oregon (State FIPS Code 41, County FIPS Code 021) is given below as an example.

Note: The filenames contain a common prefix (tgr41021.f4) followed by a single character denoting the file type.

tgr41021.f41 - Type 1: Basic data records
tgr41021.f42 - Type 2: Shape coordinate points
tgr41021.f43 - Type 3: Additional census geographic area codes
tgr41021.f44 - Type 4: Index to alternate feature names
tgr41021.f45 - Type 5: Feature name list
tgr41021.f47 - Type 7: Landmark features
tgr41021.f48 - Type 8: Area landmarks
tgr41021.f4a - Type A: Additional polygon geographic area codes
tgr41021.f4i - Type I: Area boundaries
tgr41021.f4p - Type P: Polygon locations (internal points)
tgr41021.f4r - Type R: Record number ranges

There was no Type 6 data file (additional address range and ZIP code information) available for Gilliam County. Because the TIGERTOOL user documentation suggests that Type 4, 5, and 6 files should not be converted if the information in them is not needed, these files can be renamed so TIGERTOOL will not find them under the input file prefix tgr41021.f4.

TIGERTOOL creates three output coverages:

1. <outcover_prefix>1 – contains arc (line) coordinates and polygon topology extracted from the basic data records (Type 1) and the shape coordinate points (Type 2)
2. <outcover_prefix>2 – point coverage containing polygon label points from Type P records
3. <outcover_prefix>3 – point coverage containing point landmark features from Type 7 records.

In addition, TIGERTOOL creates a collection of ARC/INFO attribute files that contain the attributes of points, lines, and polygons contained in the three GIS coverages. TIGERTOOL also builds a set of “relates” (relational joins) to link these Info attribute files to the arc attribute table (AAT) and point/polygon attribute table (PAT) files of the coverages. These “relate” definitions are named and stored in a file named <outcover_prefix>.rel and can be activated in ARC/INFO by using the RELATE RESTORE <file_name> command. Items (columns) in the related attribute files can then be accessed in ARC/INFO

commands as though they were an item in the PAT or AAT file by using the syntax `<relate_name>//<item_name>`. The attribute files created by TIGERTOOL and their associated relate names are listed below.

1. `<outcover_prefix>1.acode` – arc attributes from Type 1 records. Relate name: ACODE.
2. `<outcover_prefix>1.type3` – additional census geographic area codes, including voter tabulation districts, from Type 3 records. Relate name: TYPE3.
3. `<outcover_prefix>1.pcode` – polygon (area) attributes from Type 1 records. Relate name: PCODE.
4. `<outcover_prefix>2.typea` – additional polygon geographic area codes, including congressional districts, from Type A records. Type A files also have reserved placeholders for possible future storage of school district boundaries, traffic analysis zones, and urbanized area codes. Relate name: ACODE.
5. `<outcover_prefix>2.xcode` – polygon label points from Type P records. Relate name: XCODE.
6. `<outcover_prefix>2.typei` – area boundary identifiers from Type I records (contains both Type 1 record numbers and Type P polygon identifiers). Links Type 1 line segment records to the corresponding Type P polygon records (left and right). Relate name: TYPEI.
7. `<outcover_prefix>3.xcode` – attributes of point and area landmark features and longitude/latitude coordinates of point landmarks from Type 7 records. Relate name: TYPE7.
8. `<outcover_prefix>3.type8` – polygon identifiers for area landmarks from Type 8 records. Relate name: TYPE8.

These ARC/INFO attribute files and the predefined relates allow users of Arcplot (ARC/INFO map display subsystem) to select and display a specific theme (e.g. all hydrographic features) or a subset of features (e.g., primary and secondary divided highways) by relating the coverage to the CFCC attribute and selecting CFCC values that correspond to the desired feature types. Individual features (e.g., Interstate Highway 84) can be selected by feature name. Polygons of a specific type (e.g., census blocks boundaries) can be displayed by selecting all the line segments for which the left area identifier (e.g., census block identifier) differs from the right area identifier. Once the user has selected a group of similar features, these features can be extracted into an ARC/INFO coverage and then exported to an ArcView GIS theme for use within FEMIS.

4.0 Managing Relational Data

The relational database contains approximately 180 tables that hold information used by the application software. As described in Section 3.2, *Building Relational Data*, some of the tables are preloaded with records before the system is deployed. As the system is used, new information is added and some of the initial information may be modified or deleted.

The FEMIS application software, including the models, is largely responsible for managing the information in the relational database. This section discusses the default information in the database and then describes the general purpose query tool that allows users to browse and modify data.

In the FEMIS system, all data access protection is performed by means of user interface windows. The procedures for giving FEMIS users the correct privileges to perform their tasks are provided in the System Administration topic of FEMIS Help.

Version 1.4.6 of the relational database has improved security over previous versions. The FEMIS software uses a database schema that has limited privileges so it is no longer possible to accidentally change the structure of a table or delete a table. Also available, is the capability to change database passwords. This additional security is transparent to users of FEMIS. Section 13.2, *Database Security*, in the *FEMIS System Administration Guide* has more details on security features.

4.1 Site Default Information and Considerations

When the database for a new CSEPP site is created, a set of default information is defined that meets the specialized requirements of the site. This information is solicited from the EOC users at the site and is loaded into the EOC_Objective table for each EOC.

The type of population information in the database is another default consideration. The database is designed to contain a set of “normal condition” population counts and then have flux or change counts to account for non-normal conditions. The census data available from the government is the primary source of population information.

The census data contains counts for many categories of people, such as by age range, gender, and race. For the Utah, Alabama, and Oregon/Washington sites that have databases now, the “total population” category was the default. This contains counts for all ages, both sexes, and all races. The definition of attributes of population categories are stored in the table called Population_Definition.

The census data is gathered by asking people in residential areas how many people live at that residence. Since most people in a residence are more likely to be at home during the night than the day, these counts best define night time numbers. Also, since many families have routines that are structured around the 5-day workweek, the counts are good indicators of weekday populations while not accounting for the whereabouts of people on weekends or special events. Based on these considerations, the normal condition for population information is weekday, nighttime conditions. These counts are stored in the Population_Location table.

4.2 FEMIS Data Manager Tool

This FEMIS application has many user interface windows for accessing and managing relational data. The online help function provides a convenient user guide. A collection of the relational tables has no formal user windows and relies on a general-purpose tool to manage the records in them. This section describes how this tool is used and provides guidelines to manage the relational database while FEMIS is in use.

The FEMIS Data Manager Tool is activated by clicking on the Start → Programs → FEMIS → Database Manager. The FEMIS login window displays and the user must enter a valid username and password for the EOC database that will be accessed. Then the FEMIS Database Manager window displays.

The appearance of the window depends on the privilege of the user. Edit privilege for UN.DB_mgr is required for the full function version shown below. A view only version of the window is displayed if the user has at least View privilege for UN.DB_mgr. This contains the same information as the full function version except that no Recordset Type: Edit button is provided and no SQL window is provided. Other differences are dependent on which Form Type: is selected prior to opening a table.

Figure 4.1. FEMIS Database Manager Window

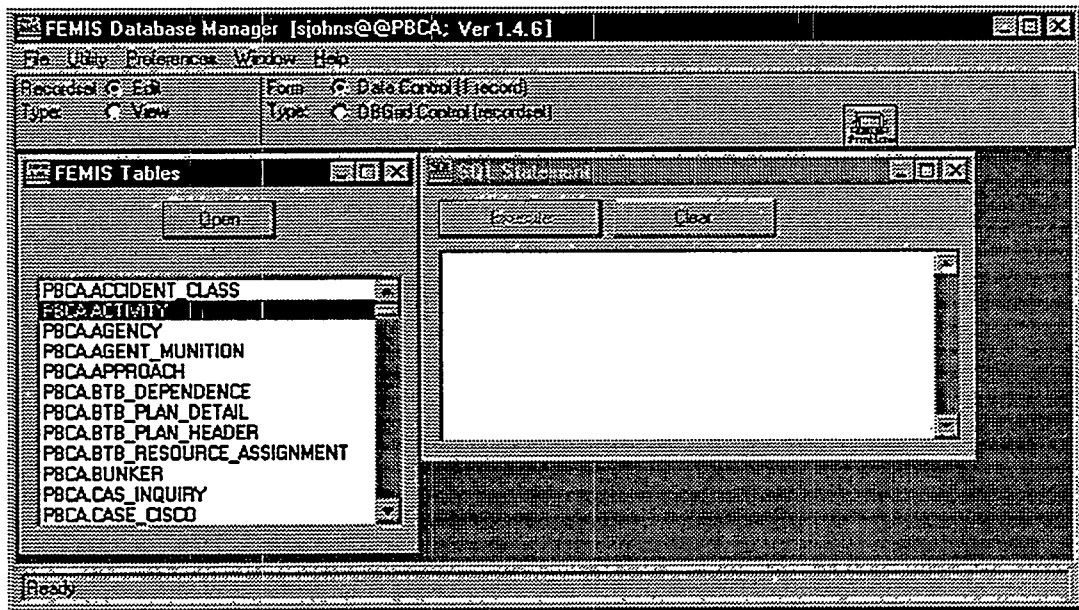

The FEMIS Tables window contains a list of all tables in the relational database which are appropriate to the user's Recordset Type: selection and the current default EOC. Replicated tables (S_XXX...) are removed from the list when in Edit mode; system tables and MLOG\$ tables are never shown.

The SQL Statement window on the right is used to formulate a user query, but normally it is not used. You can minimize it by selecting the Close option or by double-clicking on the control box in the upper left corner of this window.

Regardless of mode, two options exist for viewing the data in a table. This is controlled by selecting a Form Type. A Form Type: Data Control will present the data one record at a time with a Data Control bar to move from record to record. A Form Type: DBGrid Control will present the data in a spreadsheet format with scroll bars.

Note: The only time records can be edited are when you have selected Recordset Type: Edit and Form Type: Data Control as well as opened the table using the FEMIS Tables window. Otherwise all data is read-only.

4.2.1 Data Control

The Form Type: Data Control, which presents a single record at a time for viewing or editing (if in Edit mode), contains some additional command buttons which are sometimes useful. The Add, Update, and Delete buttons (available only in Edit mode) allow editing of the current record in the Data Control window. The Filter, Sort and Move buttons provide search and organization options for viewing the data regardless of mode. The Refresh button will requery the database and all previous sorting and filtering activities will be cleared. The Close button will close the window and prompt you to commit changes, if any were made.

Figure 4.2. Data Control on the FEMIS Database Manager Window

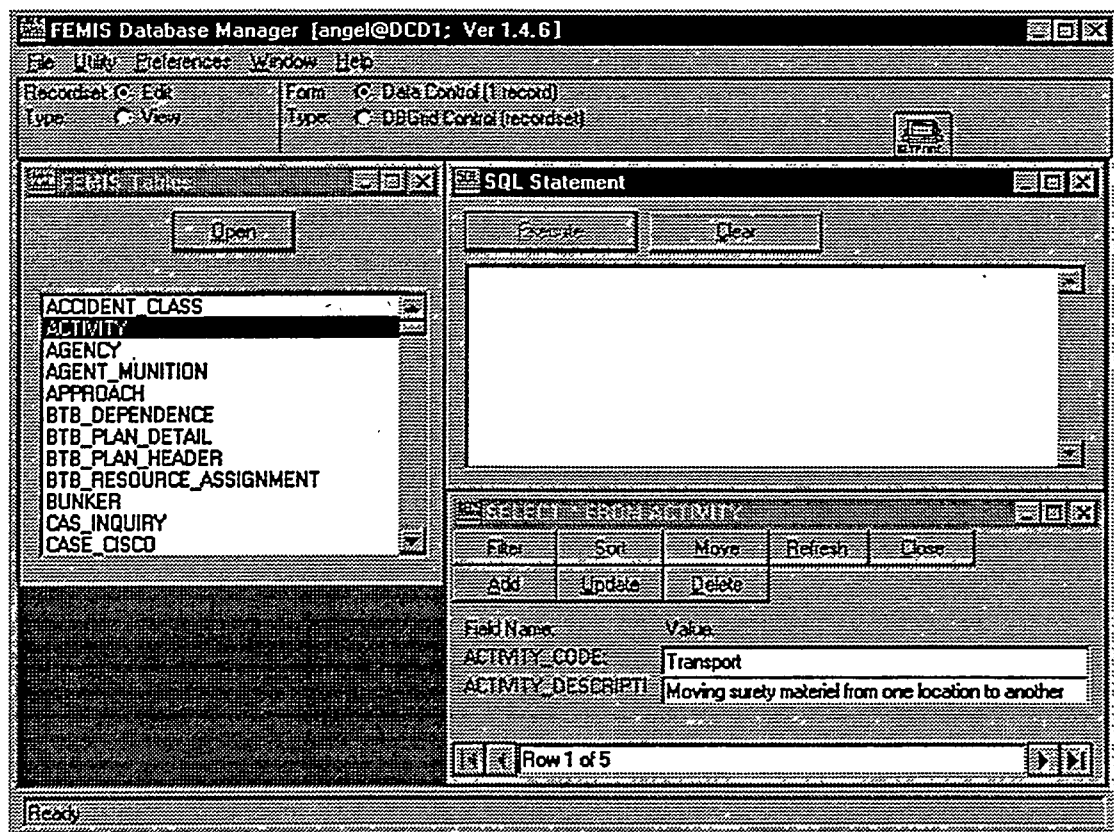

4.2.2 DBGrid Control

To view multiple records, select the DBGrid Control radio button and select a table from the list. You can double click on a table name, or highlight it and then click on the Open button. This will display a read-only window on the selected table and display it in a multi-record grid display. If the record is longer than the width of the window or there are more records available than can be shown, scroll bars are presented to view all the records and fields. The Refresh button will requery the database and all previous sorting and filtering activities will be cleared. The Sort and Filter buttons are search and organization options for viewing the records in the table. The Close button will close the window. The control bar at the bottom of the window can be used to quickly move through large numbers of records or to view current data control properties. These properties are not editable regardless of mode.

Figure 4.3. DBGrid Control on the FEMIS Database Manager Window

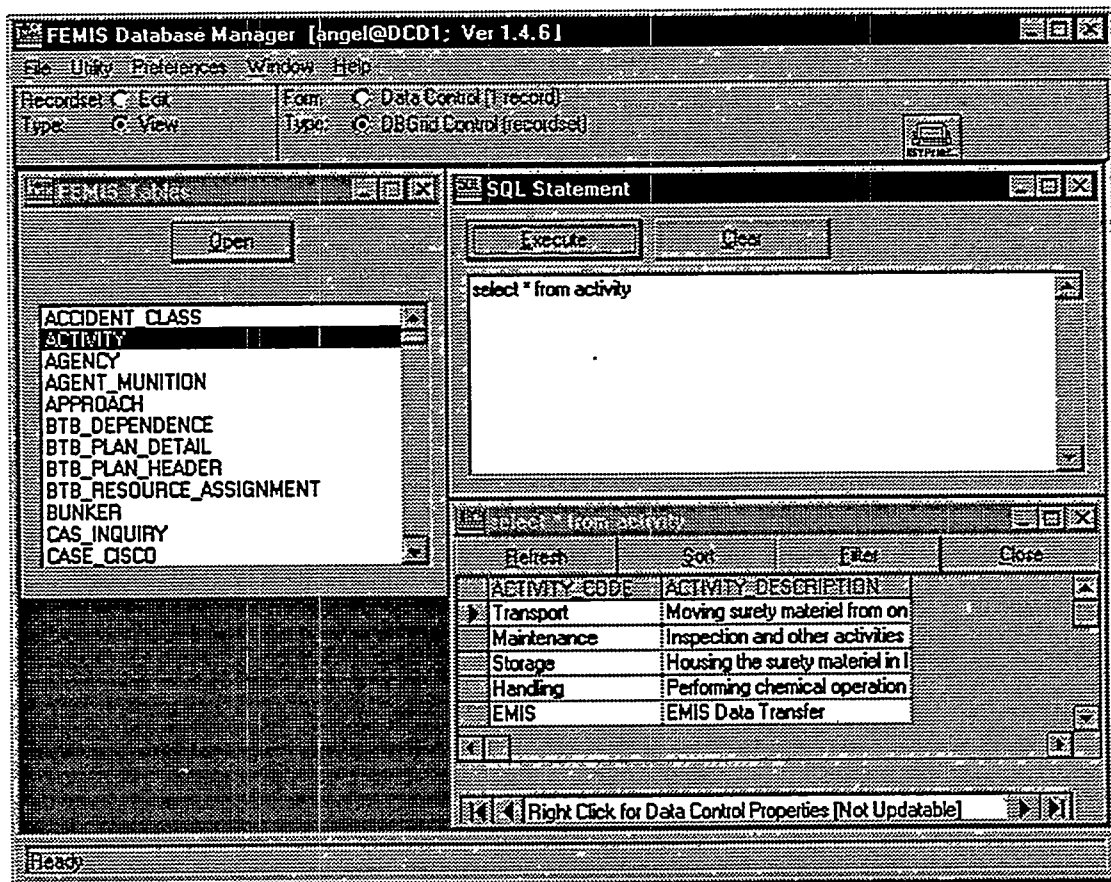

4.2.3 Other Data Manager Functions

To obtain a list of any errors you may have encountered during your session, click on Errors under the File menu. You can click on Properties to view properties of the DBEngine or Workspace and the Print entry will allow you to print the Current Screen, Current FEMIS Window, Current FEMIS Child Window or Selected Area. The Print button also provides this capability.

The Utility menu provides various options for closing windows.

The Show Performance Numbers option in the Preferences drop-down menu allows you to turn on/off the display of statistics on the opening/loading of tables. This option only applies when the Form Type: Data Control radio button is selected. It is not available when the Form Type: DBGrid Control option is selected.

4.3 Managing Relational Data

This section describes several considerations and provides some guidelines that will help you manage the relational database. Topics included are database integrity, testing modifications, managing exercise data, archiving data, and backup and recovery of the database.

4.3.1 Database Integrity

The information in the relational database has complex inter-relationships that must be maintained. FEMIS has been designed and tested to achieve this integrity.

When changes are made using the FEMIS Data Manager tool or other tools, such as SQL*Plus, care must be taken to prevent inconsistencies in the database. Only System Administrators that understand the database should use these tools to make database modifications.

4.3.2 Testing Modifications

It is recommended that any significant changes to the database should first be tested by implementing them on an exercise dataset, see Section 6.0, Managing Exercise Data. If problems are encountered, the exercise data can be easily deleted without any impact on the operational data. When the changes have been tested, then they may be applied to the operational data.

4.3.3 Exercise Data

Each time a new exercise dataset is generated, approximately one-half of the tables in the relational database gain a significant number of new records. If the obsolete exercise data is not removed, database performance may be impacted. Section 6.0, Managing Exercise Data, describes the maintenance of this type of data. Each dataset should be documented and unnecessary exercises deleted.

4.3.4 Archiving Tables

The Journal table (where events are logged) and the Met tables require some maintenance because these tables grow daily as the system is used. The frequency of archiving depends on how the system is used. For example, if FEMIS is operated 7 days a week for 24 hours a day with continuous Met feed, the MET_CONDITION table records could increase by approximately 1,000 records per day. In a month, nearly 30,000 records would accumulate, and in a year the count would be approximately 360,000. The rate of growth for the Journal table would be less than the Met tables, but after a year's time, it may approach 100,000 records. These numbers of records would not fill the tables or the database but would be undesirable to view in the Met status boards.

Data should be archived when users indicate too many records are present or when the Database Administrator determines older records in the table are no longer useful. Because the archived data can be reloaded, archival does not mean the data is lost. Once the FEMIS system use pattern is set and fairly stable, archiving can be done periodically as part of standard system administration policies.

A timed archiving capability is available to periodically remove records from these two tables. Section 14.0, Backup Strategy for FEMIS, in the *FEMIS System Administration Guide* describes how to use this capability. The manual archiving program still exists and can be used for special situations and is described below.

The archive program is located in the /home/femis/database/eocdba directory.

Note: The archive program is a generic tool for archiving two types of data for any FEMIS database. The tool will allow you to archive and delete data for other EOCs—do not archive or delete data for other EOCs unless authorized to do that task.

The following example illustrates how to archive Journal data for the onpost EOC in Utah.

Go to the directory where the archive programs are kept.

```
% cd ~femis/database/eocdba
```

Start the archive program.

```
% archive.sh
```

The first menu that displays allows you to select the database from which you wish to archive data.

```
Databases
=====
tead
ctoo
utst
=====
Choice ==>
```

For example: to archive data for the onpost EOC, enter tead.

The second menu allows you to select the type of data to archive.

```
Archive Data Menu
=====
met
journal
=====
Choice ==>
```

For example: to archive Journal data, enter journal.

Then you will see some informational messages, including the directory into which the .dmp file will be placed and the name of the .dmp file.

```
*** MSG: Output to: /files6/home/femis/dev/inf/eocdba
*** MSG: Exporting to: tead_1996-04-19-09-52_journal.dmp
```

Note: The .dmp file name includes both the date and time.

Then the actual export begins, so you will see some messages from the Oracle Export utility, exp. The name of each table and the number of records exported are also displayed; you should verify that the record count is an expected value.

When the export completes, you should see the message:

```
Export terminated successfully without warnings.
```

The following message is verifying that you saw the message above regarding the export completing successfully.

```
Did the export complete successfully? [N] ==>
```

Enter Y if the export was successful, and the program will continue and allow you to specify which data to delete. If the export did not work properly OR if you do not want to delete any data, then enter N.

Normally you will enter Y, and then you will be asked for an archive date.

Enter archive date (MM/DD/YY) [04/23/96] ==>

Any data older than the date you enter will be deleted from the database. If you want to use the default date (today), just press <Enter>.

Then you will be asked to confirm the deletion of data.

Do you really want to delete records older than 4/1/96? [N] ==>

If you do want to delete the data, enter Y.

Then the Oracle SQL*Plus utility will delete records from the table(s), displaying other status messages as it runs. The last message from SQL*Plus is the important one—how many rows were deleted? Was it the expected number?

Finally, the archive tool will display the following archive complete message and exit.

```
* * * MSG: Archive of journal in tead is complete
```

The .dmp file should then be moved to the exports directory.

```
% mv *.dmp ../exports
```

The .dmp file will be backed up to tape as part of the normal system backup process. However, the Database Administrator should periodically remove old .dmp files, especially when the volume of data is over 100MB.

4.3.5 Backup and Recovery of the Database

The database files should be backed up at regular intervals. One backup per day, during off-use times, should be sufficient; your System Administrator may decide that more frequent backups are desirable. In case of disk failures or other serious problems involving the database, the files can be restored from the last backup. See the Section 14.0, Backup Strategy for FEMIS, in the *FEMIS System Administration Guide* for additional details on backing up the database.

4.4 Data Sharing Between EOCs

Information in the EOC databases is shared between EOCs in order to provide users with a site-wide concept of the current status of conditions. In FEMIS, this sharing is done several different ways.

4.4.1 Depot Owned Tables

The simplest sharing is done with the depot tables that only the depot can modify. Examples are the BUNKER and MET_CONDITION tables. Offpost EOCs are provided with a read only copy of this data that reflects all changes made onpost. These shared tables are listed as follows:

BUNKER
CSEPP_ACCIDENT
D2_MET_SELECTION
MET_CLUSTER
MET_CONDITION
MET_TOWER
STORED_AGENT
WORK_PLAN
WORK_PLAN_ACT
WORK_PLAN_ACTIVITY

4.4.2 Site-wide Shared Tables

The other form of data sharing assembles copies of other EOC data in a site-wide view. For example, Facility table data is shared in a view named S_FACILITY that contains information from all EOCs including the local one. There are several options available for this type of data. Table 4.1 shows the tables shared with the site-wide views and indicates the default options. If additional tables are shared, a new version of FEMIS is required.

One option is to share the data conditionally based on the setting of a flag in the table. This allows changes in the local database to occur without propagation of the data until the user wants to share it (if sharing is desired). This option is not modifiable in the current release of FEMIS; if changes are desired, a new version of FEMIS would be required to account for the modifications.

The other option allows the depot to not share its data in these site-wide views. For example, the depot may not want the offpost EOCs to view its resource data. It is possible to modify this option by tailoring data sharing at the site. To do this, modify the default settings in the vuelist.tpl file in the /home/femis/database/dba directory. To remove the depot FACILITY table from the offpost S_FACILITY views, change the Restricted condition from N to Y. This modification has to be done at the time of a fresh install or a complete reinstall of FEMIS.

CAUTION

Be very careful when changing data sharing options since errors may cause FEMIS to operate incorrectly and serious errors could be introduced.

Table 4.1. Site-wide View Tables

Table Name	Conditional	Restricted
AGENCY	N	N
CONTROL_POINT	Y	N
D2_INPUT	Y	N
D2_ITEM_OF_INTEREST	Y	N
D2_I_CONCENTRATION	Y	N
D2_I_DOSAGE	Y	N
D2_I_MET	Y	N
D2_I_QUANTITY	Y	N
D2_I_RELEASE_NUM	Y	N
D2_O_POSINP	Y	N
DEPARTMENT	N	N
EXERCISE_CONTROL	N	N
FACILITY	N	N
G_DEF_COMMUNITY	N	N
G_DEF_COMMUNITY_VAL	N	N
G_DEF_EMERGENCY	N	N
G_DEF_EMERGENCY_LEVELS	N	N
G_DEF_HAZARD_CLASS	N	N
G_DEF_NAV_BUTTON	N	N
G_DEF_NAV_FUNCTION	N	N
G_DEF_NAV_FUNCTION_IO	N	N
G_DEF_PAD_LABELS	N	N
G_EMERGENCY	N	N
G_NAVIGATOR_ITEM	N	N
GENERIC_TEXT	Y	N
GEO_OBJECT	N	N
GEO_OBJECT_ZONE	N	N
GIS_LAYER	N	N
GIS_THEME_DATA	N	N
INTERVAL_QUANTITY	Y	N
JOURNAL	Y	N
KNOWN_POINT	N	N
KNOWN_POLYGON	Y	N

Table Name	Conditional	Restricted
KP_CLASS_DEF	N	N
KP_SUB_CLASS_DEF	N	N
LOCAL_CONFIG	Y	N
MEMO_UNDERSTANDING	N	N
PA_DECISION_MATRIX	Y	N
PA_UNIT	N	N
PERSON_SHELTERED	N	N
PLUME	Y	N
POLYGONAL_LAYER	N	N
POSITION	N	N
POTENTIAL_ACCIDENT	Y	N
POTENTIAL_THREAT	Y	N
PRIVILEGE	Y	N
RELEASE	Y	N
REPLICATION_TEST	N	N
RESOURCE_CATEGORY	N	N
RESOURCE_DEFINITION	N	N
RESOURCE_OWNER	N	N
RESOURCE_LOCATION	N	N
RESOURCE_MOU	N	N
SHELTER	N	N
SITUATION_SUMMARY	N	N
UDS_COLUMN	Y	N
UDS_ROW	Y	N
USER_DEFINED_STATUS	Y	N
USER_MODEL_CASE	Y	N
WEDGE_POLYGON	Y	N
WK_POSITION	N	N
ZONE_CLUSTER_IN_GROUP	N	N
ZONE_IN_GROUP	N	N
ZONE_RISK_GROUP	N	N

4.5 Security Provisions

FEMIS provides table access security so it is possible to limit access to individual tables. This access is controlled by the `tablist.tpl` template file found in the `/home/femis/database/dba` directory. This table has six columns and a row for each table in the database.

The first column is the tablename and the rest of the columns control access on the table.

The second column specifies if the table is only located at the onpost database. A Y value means that a table like BUNKER is only found onpost; a B means the table is found both onpost and offpost.

The next three columns control the select, update, and insert/delete privileges, respectfully.

The sixth column controls which administrative schema has access to the table. A B here means both the femis and oracle schema have access. An N means neither have access, while an O lets only oracle have access. An F gives only the femis schema access.

5.0 Managing Spatial Data

FEMIS spatial datasets are stored as ArcView themes (layers) and referenced by the FEMIS GIS ArcView Project (APR) file. Each theme represents a specific type of physical or geopolitical feature (e.g., roads, state and county boundaries, chemical storage locations) within the area of interest surrounding a CSEPP site. Table 3.5 lists and describes the standard FEMIS spatial themes that are required or are typically included in each CSEPP site database. Additional site-specific themes may also be included to meet the needs or interests of a specific site. The data files for each spatial theme are stored on the UNIX server in a directory structure that allows them to be easily installed on each PC. Users maintain copies of these theme files in a parallel directory structure on their client PCs for use with the ArcView GIS software. When additions or changes are made to spatial data files on the server, an update program that runs during PC login is used to update the PC's copy of those files.

The GIS LAYER and GIS_LAYER_DEFINITION tables in the relational database contain metadata that define the storage structures and display characteristics of the spatial themes. Other tables contain location information and attribute values associated with individual geographic features within a spatial theme. The GEO_OBJECT table contains unique feature identifiers that link the attribute information in the relational database to the corresponding features in the spatial data.

The FEMIS spatial data can be divided into three categories: static spatial data, user-modifiable spatial data, and model-related spatial data. These categories are discussed below.

1. Static spatial data themes cannot be modified by FEMIS users. Required changes or upgrades to these themes occur infrequently and are managed and controlled by the System Administrator. Examples of static spatial themes are roads, census blocks, and emergency planning zone boundaries.
2. User-modifiable spatial data themes can be modified by authorized users from within certain FEMIS modules. These modifications may include addition and deletion of map features (objects) and modification of the location and other attributes of existing map features. The changes are first applied to the FEMIS relational database. The FEMIS software then updates the corresponding spatial themes in ArcView based on the values in the relational database. Facilities and traffic control points are examples of user-modifiable spatial themes.
3. Model-related spatial data themes are created dynamically for each model case that is run. These themes are temporarily generated and stored on the user's PC as needed.

5.1 Static Spatial Datasets

The following paragraphs briefly describe the management and maintenance process for the static FEMIS spatial themes that cannot be modified by FEMIS users.

5.1.1 Census Blocks

Census enumeration district boundaries are maintained by your System Administrator. Changes in the data would normally originate from updated TIGER/Line data files from the U.S. Bureau of the Census. The entire census block theme would be regenerated from the new TIGER/Line files for the included counties or other geographic areas. Changes in the values of the Population attribute for each census unit may also need to be made as new census statistical data becomes available.

5.1.2 County Boundaries

The county boundaries theme is maintained by your System Administrator. Changes in the data would normally originate from updated TIGER/Line data files from the U.S. Bureau of the Census. Depending on the nature and magnitude of the changes, your System Administrator could choose either to regenerate the entire theme from the new TIGER/Line files (the recommended method), or to use a spatial data editing tool to edit the existing county boundaries theme.

5.1.3 Accident-Based Planning Categories

Your System Administrator is responsible for maintaining this theme. If changes in the planning category boundaries are recommended for your site, the theme can be regenerated by running the ArcView/Avenue script createABPC, using the desired parameter values for center location and radius.

5.1.4 Igloos (Point Theme)

The igloo point location theme is maintained by your System Administrator. Changes in the onpost igloo data (due to igloo construction or destruction or a correction in the location and/or content of an existing igloo) are made by updating the igloo information in the relational database and then running GENGIS (a FEMIS data utility script) to regenerate the ArcView event theme text file. The igloo event file is then used to generate an event theme in ArcView GIS, from which the shape files for the igloo theme are created.

5.1.5 Emergency Planning Zones

The emergency planning zones theme is maintained by your System Administrator. Changes in the data, necessitated by changes in zone boundaries or the addition of new zones, can be made by using the Zone Editor tools in the FEMIS GIS APR to modify or add zone boundaries and/or change zone attributes. The Zone Editor tools also generate zone modification files. These files are then read by a UNIX shell script which generates and runs a sequence of SQL database scripts to make the corresponding updates to the ZONE table and other related tables in the FEMIS relational database. See Section 9.3, Zone Editor, in the *FEMIS System Administration Guide* for instruction on how to use the Zone Editor tools and scripts.

5.1.6 Depot Zones

The Depot Zones theme, which consists of the Chemical Limited Area (CLA) boundary plus any other onpost zones that the site desires to include, is maintained by your System Administrator. Changes to the Depot Zones theme can be made by replacing the theme in its entirety with new data, by using a spatial data editing tool to graphically edit the existing Depot Zones theme, or by performing the following steps: 1) Edit the original ARC/INFO Generate text file that contains the polygonal vertex locations for the CLA boundary and any other included depot sub-zones; 2) use the edited file to recreate the ARC/INFO Depot Zones coverage; and 3) convert the coverage to an ArcView shape file set.

5.1.7 Met Towers

The Met tower point location theme is maintained by your System Administrator. If a new Met tower is constructed, an existing tower is taken out of service or a correction is needed in the location data for an existing tower. The changes would be made by updating the information on Met towers in the relational database and then running GENGIS (a FEMIS data utility script) to regenerate the ArcView event theme text file. The Met tower event file is then used to generate an event theme in ArcView, from which the shape files for the Met tower theme are created.

5.1.8 Administrative Boundaries

Administrative boundaries (e.g., national forest boundaries, military reservation boundaries) are maintained by your System Administrator. Changes in the data would likely originate from new or updated United States Geological Survey (USGS) Digital Line Graph (DLG) data, which was the original source of the IBS administrative boundaries data. Depending on the nature and magnitude of the changes, your System Administrator could choose either to regenerate the entire theme from the new USGS data files (the recommended method), or to use a spatial data editing tool to edit the administrative boundaries theme.

5.1.9 Road Themes (Detailed, Major)

Road network themes (Detailed and Major) are maintained by your System Administrator. Changes in the data would likely originate from updated TIGER/Line data from the U.S. Bureau of the Census. Depending on the nature and magnitude of the changes, your System Administrator could choose either to regenerate each affected theme from the new TIGER/Line files (the recommended method), or to use a spatial data editing tool to edit the appropriate road themes.

5.1.10 Railroads

The railroads theme is maintained by your System Administrator. Changes in the data would likely originate from updated TIGER/Line data from the U.S. Bureau of the Census. Depending on the nature and magnitude of the changes, your System Administrator could choose either to regenerate the entire theme from the new TIGER/Line files for the affected counties (the recommended method), or to use a spatial data editing tool to edit the existing railroads theme.

5.1.11 Streams and Water Bodies

The streams and water bodies theme is maintained by your System Administrator. Changes in the data would likely originate from updated TIGER/Line data from the U.S. Bureau of the Census. Depending on the nature and magnitude of the changes, your System Administrator could choose either to regenerate the entire theme from the new TIGER/Line files for the affected counties (the recommended method), or to use a spatial data editing tool to edit the existing streams and water bodies theme.

5.1.12 Elevation Contours

The elevation contours theme is maintained by your System Administrator. Changes in the data would likely originate from new or updated USGS elevation data, which was the original source of the IBS elevation contours data. Depending on the nature and magnitude of the changes, your System Administrator could choose either to regenerate the entire theme from the new USGS data files (the recommended method), or to use a spatial data editing tool to edit the existing elevation contours theme.

5.1.13 Image Maps

Image maps are maintained by your System Administrator. Revised image maps are incorporated into the spatial database in the same manner as the original image maps were installed (registration to the target map projection in ARC/INFO or other geo-referencing software, conversion to a TIFF formatted file, integration with other images as necessary, and export to ArcView). A revised image map of an area previously represented would replace the obsolete image map file of the same area. An image map of an area not previously represented could be added to the image files.

5.2 User-Modifiable Spatial Datasets

This section discusses facility, traffic control point, siren, and known point themes. Users that have the appropriate privileges can modify these themes from within FEMIS.

5.2.1 Facilities

Users can add, delete, or modify facility locations and attributes in their EOC from within FEMIS. After a user has finished making the changes and submits the new information to the database, an SQL-PASSTHRU query is automatically run from the FEMIS application. This query updates the appropriate database tables and creates an ASCII event file that is used to regenerate the facility theme. Your System Administrator can update the facility theme by following the same process.

5.2.2 Traffic Control Points

Users can add, delete, or modify traffic control point locations and attributes in their EOC from within FEMIS. After a user has finished making the changes and submits the new information to the database, an SQL-PASSTHRU query is automatically run from the FEMIS application. This query updates the

appropriate database tables and creates an ASCII event file that is used to regenerate the traffic control point theme. Your System Administrator can update the traffic control point theme by following the same process.

5.2.3 Sirens

Users can add, delete, or modify warning siren locations and attributes in their EOC from within FEMIS. After a user has finished making the changes and submits the new information to the database, an SQL-PASSTHRU query is automatically run from the FEMIS application. This query updates the appropriate database tables and creates an ASCII event file that is used to regenerate the siren theme. Your System Administrator can update the siren theme by following the same process.

5.2.4 Known Points

Users can add, delete, or modify known point locations and attributes in their EOC from within FEMIS. After a user has finished making the changes and submits the new information to the database, an SQL-PASSTHRU query is automatically run from the FEMIS application. This query updates the appropriate database tables and creates an ASCII event file that is used to regenerate the known point theme. Your System Administrator can update the known point theme by following the same process.

5.3 Model-Related Spatial Datasets

Model related spatial datasets include the following themes: D2PC plumes, Threat Area wedges, Evacuation nodes, Evacuation links, and Evacuation centroids. For each of these themes, the actual ArcView GIS files are created dynamically by the FEMIS application and stored temporarily on the PC. No model spatial data files for the GIS are stored on the server.

5.3.1 D2PC Theme Data (Plume Contours)

Although D2PC theme files are stored on the PC, they are actually regenerated each time a D2PC plume plotting function is invoked by the FEMIS application. D2PC themes are temporarily created and displayed on the map as needed and are not part of the permanent FEMIS spatial database.

5.3.2 Threat Area Wedge Theme Data

Threat Area wedge theme files are regenerated on the PC each time a plume-based threat area or user-defined threat area plotting function is invoked by the FEMIS application. Threat area wedge themes are temporarily created and displayed on the map as needed and are not part of the permanent FEMIS spatial database.

5.3.3 Evacuation Theme Data

Evacuation theme data is stored in the database and used to generate GIS files within ArcView on a PC by PC basis. For example, if someone changes some geographic information for an evacuation case on one PC, the evacuation grid for that case will need to be regenerated on any other PC to utilize the latest information. The GIS layer for an existing evacuation case may be generated on any PC by using the Create Network option contained within the evacuation interface.

6.0 Managing Exercise Data

Training and readiness are evaluated through exercises. The FEMIS system supports training or exercise of any aspect of the system's use while still maintaining the integrity of the real world data and situation. In Exercise mode, FEMIS uses copies of the real data so the exercise can be as similar to real world use as possible. Both Planning and Operational modes exist under exercise.

An exercise situation can be set up to meet exercise objectives. Over 90 of the tables in the relational database are used for exercises. Each table can contain data for many exercises. This section describes how to manage this type of data.

When you are in Exercise mode, a bicycle icon is displayed on FEMIS windows.



6.1 Selecting Exercise Modes

To start the Exercise model from the Select Mode window, click on either the Operational or Planning button located on the right side of this window. You will use these modes for training or formal site exercises.

Figure 6.1. Select CSEPP Mode Window

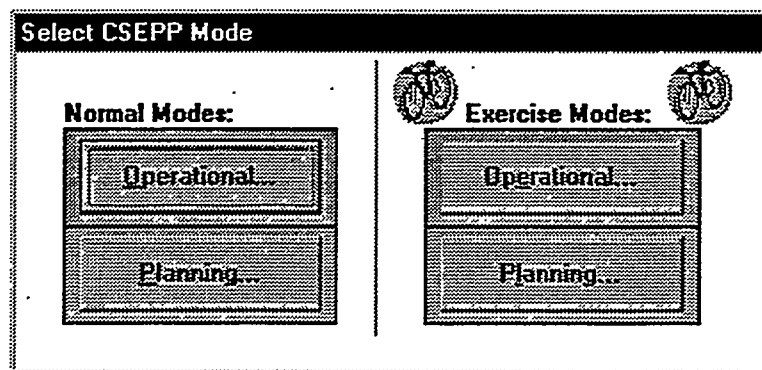

The Select Exercise window is displayed with a drop-down list so you can select an exercise. After you have selected an exercise, the Tracking Navigator window is displayed.

Figure 6.2. Select Exercise Window

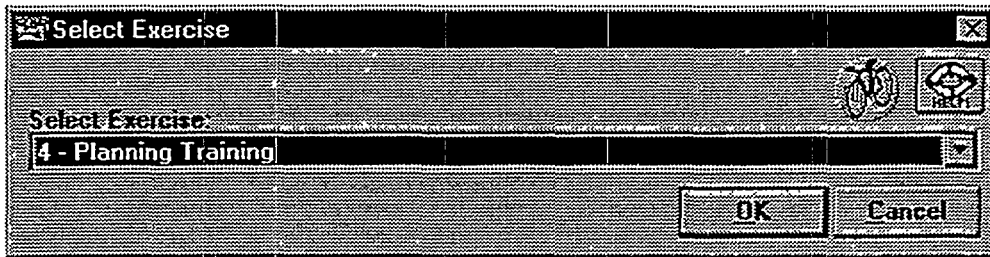

To create, modify, or delete an exercise, click on Utility → System Utilities → Exercise Setup on the FEMIS menu bar, and the Exercise Setup window displays. By clicking on the All EOCs radio button, you can see all of the exercises for all of the EOCs for a site.

Figure 6.3. Exercise Setup Window

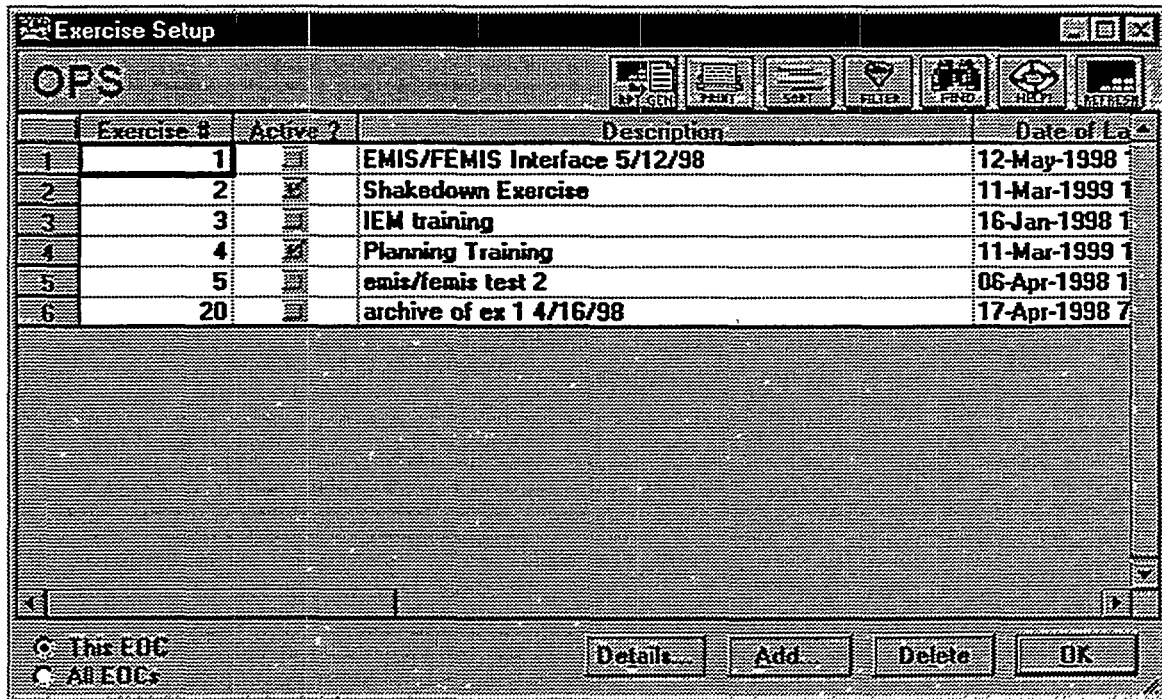

6.2 Creating an Exercise

FEMIS enables the appropriate environment to be created for a desired exercise. Because exercise objectives may require particular circumstances, the user should have a clear understanding of the new exercise before proceeding.

On the Exercise Setup window, click the Add button to display the Create Exercise window.

To create a unique exercise, click on the drop-down list to display the available choices for the Source of Data to Copy to This Exercise. Usually you will want to use real operational data as the basis of the new exercise, so you will select 0 ->> Real Operations data from the list. You can also select an existing exercise, assign it a new number, and later modify it serve your exercise purpose (see Section 6.3, Modifying an Exercise).

The Mini Onpost Exercise for Event Declaration checkbox is available only for the onpost EOC. It copies only the data necessary to declare an event and should only be used for declaring events. The Copy Evacuation Data checkbox allows the Evacuation tables to be copied. Due to the size of these tables, use this option sparingly. The Release Exercise after Creation checkbox is used to manage when users can start using the new exercise.

To save the new exercise, click the OK button. Click Cancel to exit without creating a new exercise. A message window will be displayed when the exercise has been created and will display how many records were copied.

FEMIS will ensure data integrity between exercise, real, and planning data. During an exercise some data may be entirely simulated while other data may be real. FEMIS enables you to specify when the data is real in as non-obtrusive a way as possible.

During the exercise itself, FEMIS supports exercise control by allowing the controller to inject information into the exercise data, use E-mail, and review the exercise using FEMIS status boards.

Figure 6.4. Exercise Setup: Create Exercise Window

The screenshot shows a dialog box titled "Exercise Setup: Create Exercise". It has a standard Windows-style title bar with minimize, maximize, and close buttons. The dialog contains the following elements from top to bottom:

- A label "Enter Exercise Number:" followed by a single-line text input field.
- A label "Source of Data to Copy to This Exercise:" followed by a dropdown menu currently displaying "0 ->> Real Operational data".
- A label "Brief Description of New Exercise:" followed by a single-line text input field.
- A label "Detailed Description of New Exercise:" followed by a multi-line text area.
- Three checkboxes at the bottom left:
 - Release Exercise after Creation
 - Mini Onpost Exercise for Event Declaration
 - Copy Evacuation Data
- Two buttons at the bottom right: "OK" and "Cancel".

6.3 Modifying an Exercise

FEMIS enables the system manager/exercise director to modify an existing exercise to fit changing site requirements.

To modify an exercise, select the exercise to modify from the spreadsheet and click the Details button on the Exercise Setup window. The Exercise Setup: Modify Exercise window is displayed with the details of the selected exercise loaded in the various fields. Click the OK button to save your changes. Click Cancel to exit without modifying the exercise.

Figure 6.5. Exercise Setup: Modify Exercise Window

The screenshot shows a window titled "Exercise Setup: Modify Exercise". It has a title bar with a question mark icon, a close button, and a maximize button. The window contains the following elements:

- Exercise Number:** A text input field with a small grid icon to its right.
- EDC Name:** A text input field containing "Benton County EDC".
- Brief Description of Exercise:** A text input field containing "EMIS/FEMIS Interface 5/12/98".
- Detailed Description of Exercise:** A text input field containing "CSEPP Exercise May 1998".
- Release Exercise:** An unchecked checkbox.
- Edit:** A selected radio button.
- View:** A selected radio button.
- Buttons:** "OK" and "Cancel" buttons at the bottom right.
- Icons:** "HELP" and "FRESH" icons in the top right corner.

At this point, you can modify the exercise to fit your needs by using the FEMIS user interface and the FEMIS Data Manager. The Brief Description of Exercise and the Detailed Description of Exercise fields should be modified to indicate details of the modified exercise.

6.4 Deleting an Exercise

FEMIS enables you to delete an exercise without affecting the Operational mode.

Exercises take up a lot of database space. To keep your database from filling up with exercises, delete them as necessary.

To delete an exercise, select the exercise from the Exercise Setup spreadsheet, and click the Delete button. To confirm that you want to delete the selected exercise, click the Yes button. Click No to exit without deleting an exercise.

7.0 Managing Meteorological (Met) Data

Meteorological (Met) information is normally supplied continuously by EMIS or the subsystem that collects data from the towers. The subset of data required for dispersion modeling is stored in the relational database in real time. As shown in Figure 1.1, the EMIS server collects the data and sends it to the UNIX server where it is loaded into the MET_CONDITION database table. If EMIS is used for the onpost EOC, EMIS will supply the meteorological data, and DEI (Data Exchange Interface) will load it into the same MET_CONDITION table in the FEMIS database.

For the FEMIS UNIX Met subsystem to operate correctly on the UNIX server, a tower configuration file must be available. This file contains information about the Met towers and sensors for the site. An example of this file, METTOWER.DAT, is shown in Table 7.1. When the FEMIS system is installed, this file may need to be modified to reflect the current configuration.

Data records will accumulate in the MET_CONDITION table while the Met collection subsystem is in operation. Because there is no automated archive function that removes old data, archiving has to be done periodically by the Database Administrator or a user that is familiar with Met data (see Section 4.3.4, Archiving Tables). To illustrate how the data records accumulate, we will use the example of 10 towers with each tower providing 4 data records every hour. Each record is about 100 bytes so this amounts to nearly 3MB a month.

$$10 \text{ towers} \times \frac{4 \text{ records}}{\text{hr}} \times \frac{24 \text{ hr}}{\text{day}} \times \frac{30 \text{ day}}{\text{month}} = \frac{28,800 \text{ records}}{\text{month}}$$

Note: If you do not archive the meteorological data weekly, you may not be able to delete the data because the rollback segment will be too small.

An automated method to archive Met data is provided as a UNIX cron job. When this cron job is activated, the Met data will be archived periodically, usually once per week. For more details, see Section 14.1.4, Removing Historical Met, D2PC, and Journal Log Data, in the *FEMIS System Administration Guide*.

If site policy requires that the old information has to be saved, then the data must be copied to a permanent media for the archiving.

Table 7.1. METTOWER.DAT File Example

Type	Description	Data Units
1	Wind Speed	m/sec, km/hr, ft/sec, miles/hr, knots
2	Wind Direction	deg
3	Wind Gust Speed	m/sec, km/hr, ft/sec, miles/hr, knots
4	Wind Gust Direction	deg
5	Wind Sigma	deg
6	Air Temperature	C, F
7	Relative Humidity	%
8	Atmospheric Pressure	mm_hg, in_hg, atm, bar, mil bar, psi
9	Height of Mixing Layer	m, km, ft
10	Cloud Height	m, km, ft
11	Cloud Cover	%
12	Rain Gauge	mm, cm, inches
13	Tipping Bucket	#
14-98	Unused/Unknown	
99	Battery Voltage	(volts)

```

TOWER_ID towerid lat(deg min sec dir) lon(deg min sec dir)
CLUSTER clusterid height-in-meters
SENSOR sensorid type units
TOWER_ID 00000001 37 44 03.85 N 084 11 45.70 W
CLUSTER 00000001 15
SENSOR 01 99 volts
SENSOR 61 01 m/sec
SENSOR 63 02 deg
SENSOR 64 04 deg
SENSOR 66 06 C
TOWER_ID 00000002 37 41 35.94 N 084 11 09.52 W
CLUSTER 00000001 15
SENSOR 01 99 volts
SENSOR 51 01 m/sec
SENSOR 53 02 deg
SENSOR 54 04 deg
SENSOR 56 06 C
    
```

8.0 Managing Evacuation (Evac) Data

Evacuation model case data is managed from the Evacuation Case interface by activating the Edit radio button and then selecting an option under the pull-down File menu. These options enable you to 1) create a new evacuation case, 2) open an existing case, 3) save an existing case with a new case number, 4) delete a case, 5) import a case, and 6) export a case.

8.1 Creating an Evacuation Case

CAUTION

Creating a new evacuation case is an involved process and is not recommended for those without FEMIS evacuation software training

To create a case, click the New Case menu item under the File pull-down menu on the Evacuation Case window.

Figure 8.1. Evacuation Case Window

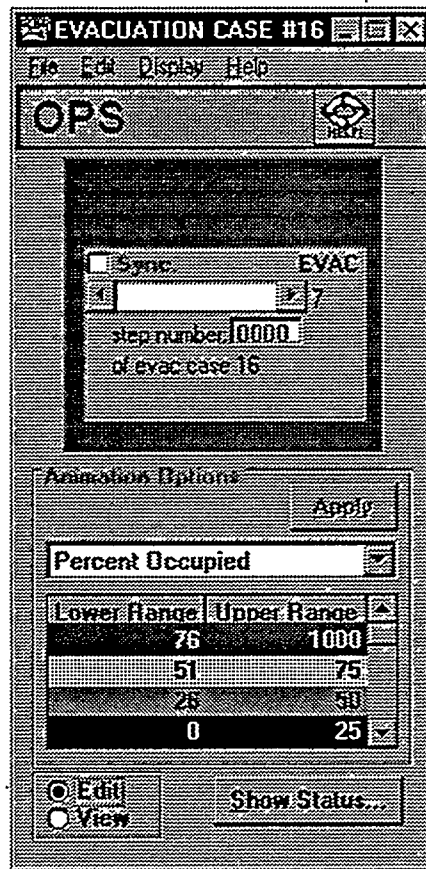

The New Case window displays with a suggested case number for the new case. You can enter your own case number, if you do not want to use the suggested case number. After you click OK, a window to enter a case description, affected evacuation zones, and case conditions will display. Once you have entered this information and clicked the OK button, the (Add) Case Parameters: Evac Case # window is displayed. This window contains high level case information, such as case identification, run control, and time period/output control. Once you fill out this form, click the OK button. The next step is to actually build the evacuation network and add a traffic load to it. To create the network, use the Add options under the Edit pull-down menu. To modify the network, use the Modify options under Edit pull-down menu.

8.2 Opening an Existing Case

When you select Open Case from the File pull-down list, the Open Evacuation Case window displays with a list of available evacuation cases. Select a case from the list and click on the OK button to open the case.

If you want to preview a complete description of a case, highlight the case and then click the View Desc button. If you want your current case to be highlighted, you can click the Show Current button. To clear highlighted cases, click on the Clear button.

Figure 8.2. Open Evacuation Case Window

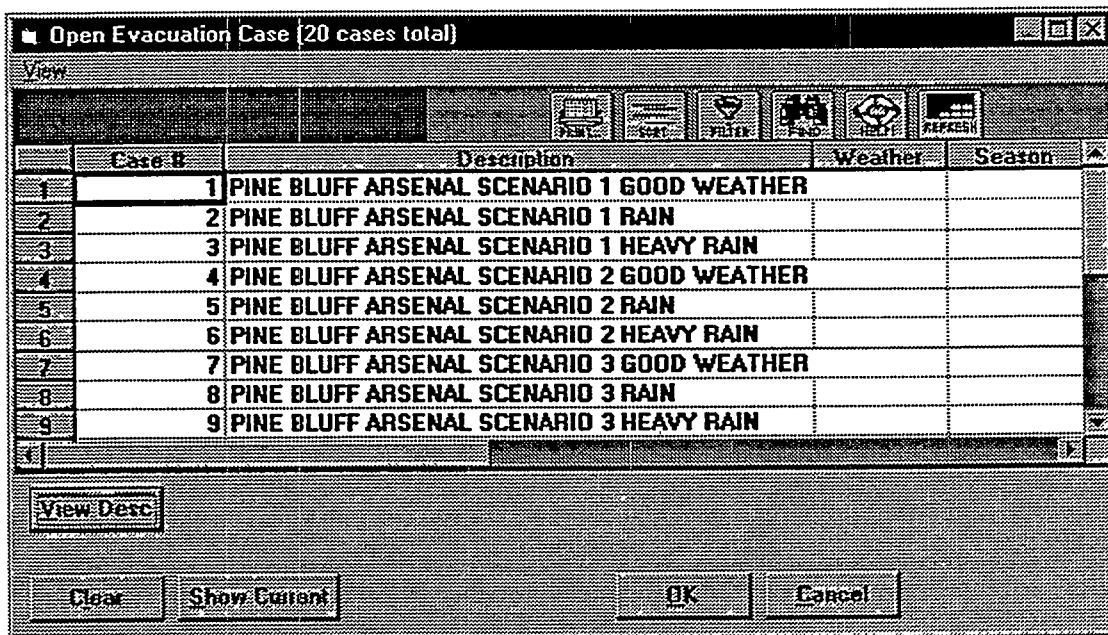

8.3 Saving an Evacuation Case

Changes made to an evacuation case are saved as you modify the case. It is therefore unnecessary to have a special save option for the evacuation case shown in the interface. If you want to save your current case

with a new case number, use the Save Case As option from the File pull-down menu. This option will copy all the input of your current case to a new case number, and you can then modify the new case as desired.

Figure 8.3. Save Evacuation Case As Window

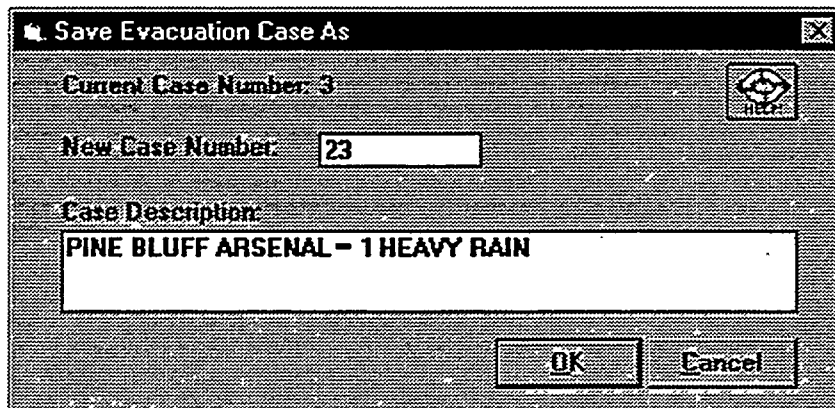

8.4 Deleting an Evacuation Case

To delete an evacuation case, complete the following steps.

1. Select Delete Case from the File pull-down menu. A window with a listing of evacuation cases will display.

Figure 8.4. Delete Evacuation Case Window

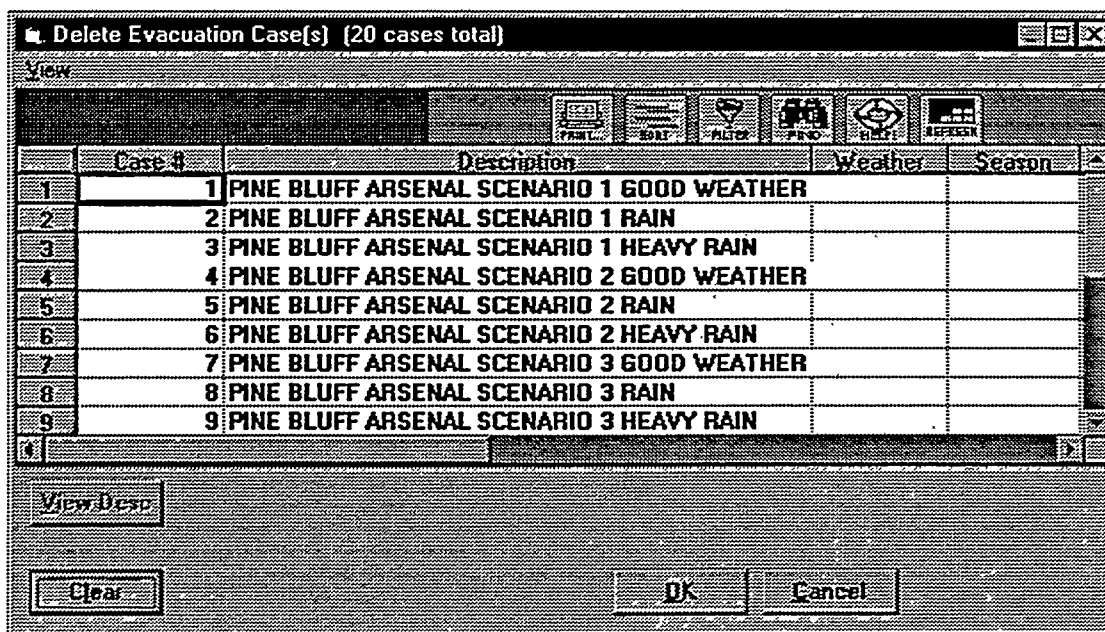

2. Select the case or cases you want to delete. If you want to delete more than one case, hold down the <Ctrl> key while you click in the row number column of the additional cases. To delete contiguous rows (cases), you can either hold down the <Shift> key while you click in the row number column of the first and last cases to be deleted or drag the cursor over the rows to select the range of cases to be deleted. Click the OK button. A message will display requesting verification of the cases to be deleted. Click the Yes button to delete, or click the No button to cancel.

8.5 Importing an Evacuation Case

FEMIS can import existing ESIM or IDYNEV (Interactive DYNAMIC EVacuation) input files for execution. Generally, IDYNEV input files come from IBS, and ESIM input files come from OREMS. Before you can import a file, you must know whether it is an ESIM or IDYNEV file. The import file must also be accessible from your PC.

CAUTION

If you transfer an input file from one platform to another, verify that the carriage returns were properly converted and the first column in the file was not deleted.

To verify, bring up the new PC file into a DOS editor and compare it with the original file on the other platform. If they are different, the import utility will not be able to import the file without some cleanup.

To import an evacuation case, complete the following steps.

1. Select the Import Case option from the File pull-down menu, and the Import File Selection window will display.

Note: Evacuation case files will usually have a .in, .dat, or .tdt file name extension.

2. To find the file you want to import, click on the drive and file path names until the file you want is listed. Select the file from the list and click on the OK button. The Import Case window will display.
3. A new suggested case number will be displayed in the New Case Number field. You can accept this case number or enter your own. Case numbers must be unique within an EOC for a particular exercise. If you select a case number which is already in use, you will be warned, and a new case number will be suggested.

Indicate the type of file you are importing: ESIM (OREMS, FEMIS) or IDYNEV (IBS) by clicking on the radio button next to the appropriate file type. Verify that the case is in the correct area of the world, and click the OK button to complete the import process.

When the file import is complete, the system will display a message box stating the import is complete. The message also asks if you want to make the imported case your current case.

Figure 8.5. Import Case Window

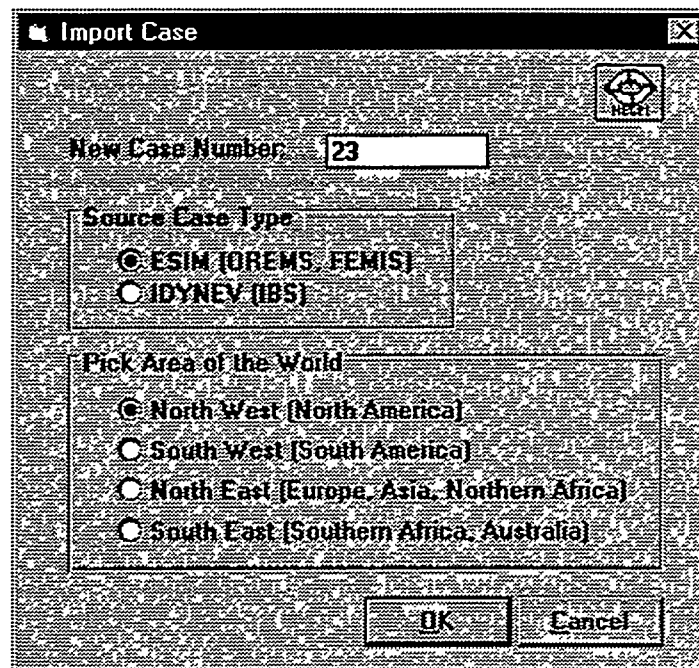

4. To make the imported case your current case, click on the Yes button. Click the No button to keep your current case (the imported case will be added to your evacuation case list where you can open it later).

Note: The import function only imports input information. You will need to run the case before output information can be viewed.

8.6 Importing Incomplete Evacuation Cases

Generally evacuation cases must be complete to be used. The following exceptions have been accounted for in the import utility.

1. If you import a case that lacks complete specification of node coordinates: This will happen if IDYNEV type 36 node offset specifications are provided but no type 6 record model origin is provided because the system cannot provide actual longitude and latitude for nodes. It will use a default value for the model origin (based on hemisphere) to create node locations. You will then need to use the map tools to move the network into alignment with the map although the system will automatically place it in your map area, if you so specify. A window with one or more diagnostics messages will be presented. The first diagnostic message should be

No type 6 case origin record was found yet record type 36 offsets were present. A default origin based on hemisphere was used.

2. If you import a case that lacks type 36 coordinate offsets and also lacks type 195 node coordinate specifications, you will get a diagnostic message, such as

No type 36 offsets were present and no type 195 coordinates were found. Although the case may be imported, it will not be possible to create a meaningful map graphic.

In addition, a variety of turn movement and other adjustments are attempted for IDYNEV cases that do not follow all the rules of case topology required by ESIM. Such corrections will produce diagnostics messages and provide before and after values for the fields modified.

8.7 Exporting an Evacuation Case

The export function allows a user to create an ESIM input file based on an evacuation case stored in the database. This function may be useful if you want to share cases with another EOC. The case could be exported from one EOC database and imported to another EOC database.

To export a case, open the case, and select the Export Case option from the File pull-down menu. Enter the filename you want to be created and select the directory in which the new file is to be placed. Once this is done, click the OK button and the file will be exported.

9.0 Managing D2PC Model Data

D2PC model data is managed from the D2PC interface by selecting an option under the pull-down File menu. These options enable you to: 1) Open Case(s), 2) Save Case or Save Case As, 3) Delete Case(s), and 4) Import Case(s). You can archive D2PC Cases using UNIX scripts (see Section 9.4, Archiving D2PC Cases).

Figure 9.1. D2PC Interface Window

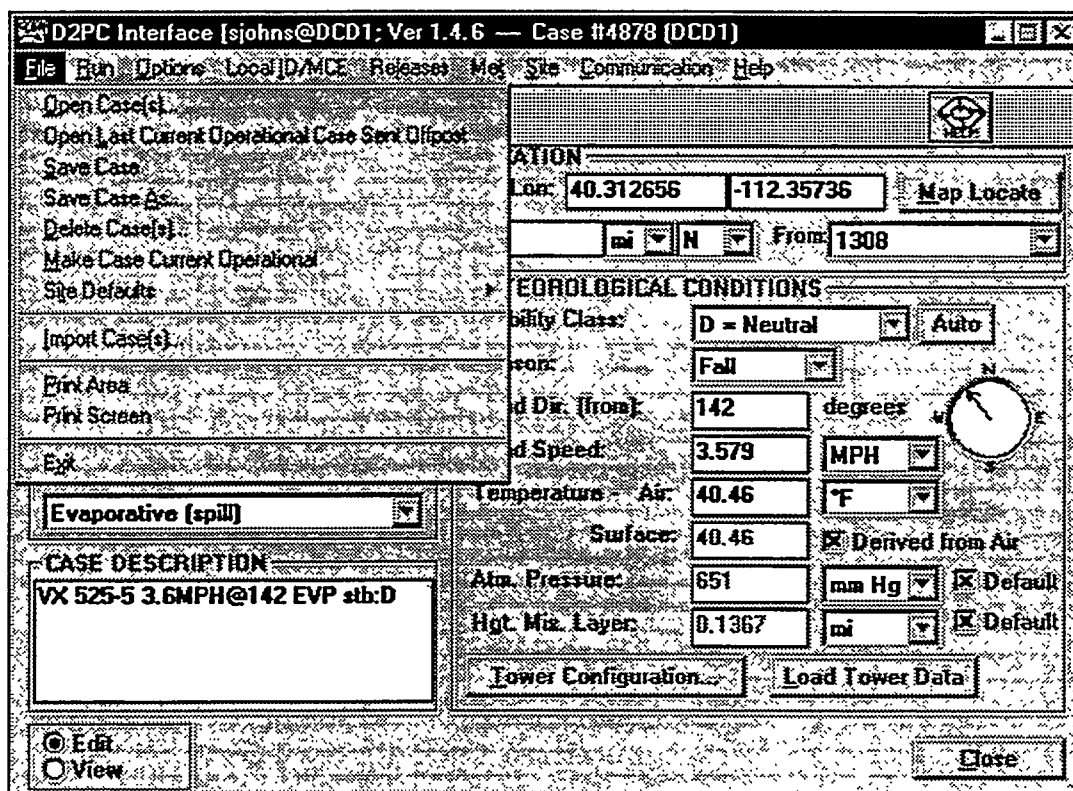

9.1 Opening a D2PC Case

When you select Open Case(s), the Open D2PC Case window displays with a list of the available D2PC cases. You have two options to open a case. To open a case from the list, either double-click on the left-most column of the case you want to open or click once to highlight the case and then click the OK button. When this window displays, the current case associated with your dataset is highlighted. If you want to clear the highlighted case, click on the Clear button. To redisplay the current case, click on the Show Current button and the current case will be highlighted.

By opening more than one D2PC case, you can have these cases plotted on the map at the same time. To open more than one case, hold down the <Ctrl> key while clicking on additional cases. To open contiguous rows (cases), either hold down the <Shift> key while you click in the row number column of the first and last cases to be opened or drag the cursor over the rows to select a range of cases. Each case

number will be added to the Current Case a pull-down list on the Open D2PC Case window above the OK button. From this list, select the D2PC case you actually want to view in the D2PC interface. The other cases will not display in the D2PC interface but will be plotted on the map the next time you select the Run and Plot Model Results option.

Figure 9.2. Open D2PC Case Window

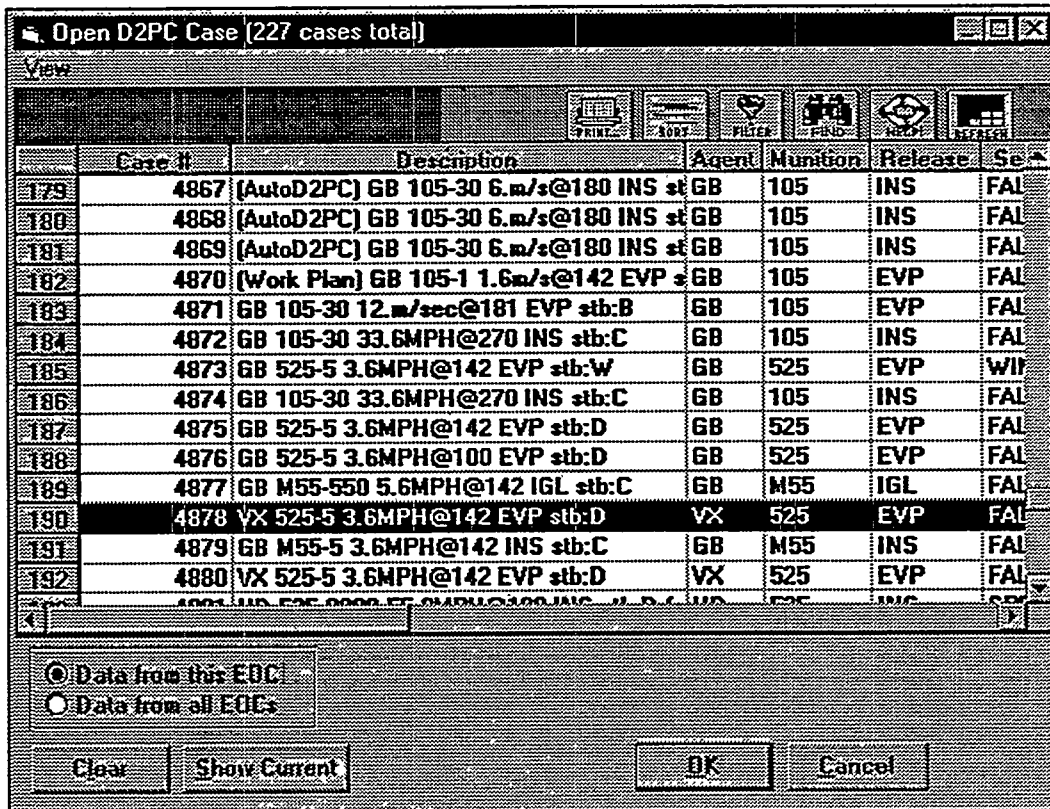

9.2 Saving a D2PC Case

The Save Case(s) option enables you to save any changes to the current D2PC case. You must activate the Edit radio button on the D2PC interface. The Save Case(s) option saves your changes to the case you currently have open. To save D2PC case changes to a new case, use the Save Case As option.

The Save Case As option enables you to save D2PC case changes to a new case number which creates a new D2PC case.

1. When you select this option, a window similar to the following example will display.
2. A suggested new case number will be displayed in the New Case Number field. If the suggested case number is not acceptable, enter your own number.

3. Type a case description in the Case Description field or accept the default description. You can enter details such as type of release, wind speed, and temperature.

Figure 9.3. Save D2PC Case As Window

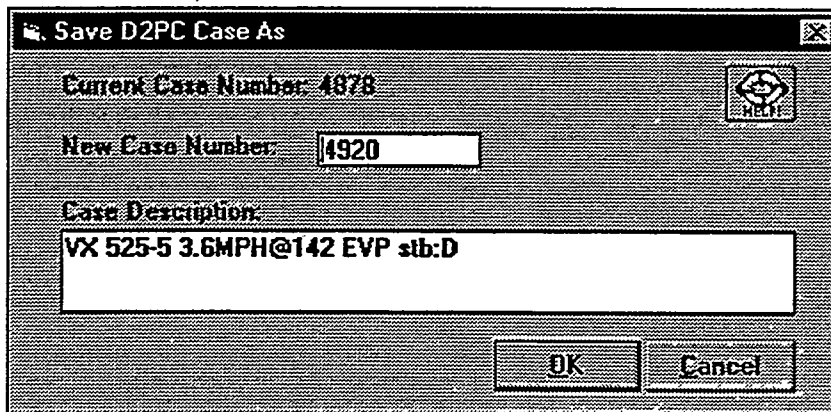

4. Click on the OK button to save the D2PC case to the new case number, or click on the Cancel button to quit without saving the case.

9.3 Deleting a D2PC Case

1. Select Delete Case(s) from the File pull-down menu. A window similar to the following will display.

Figure 9.4. Delete D2PC Case(s) Window

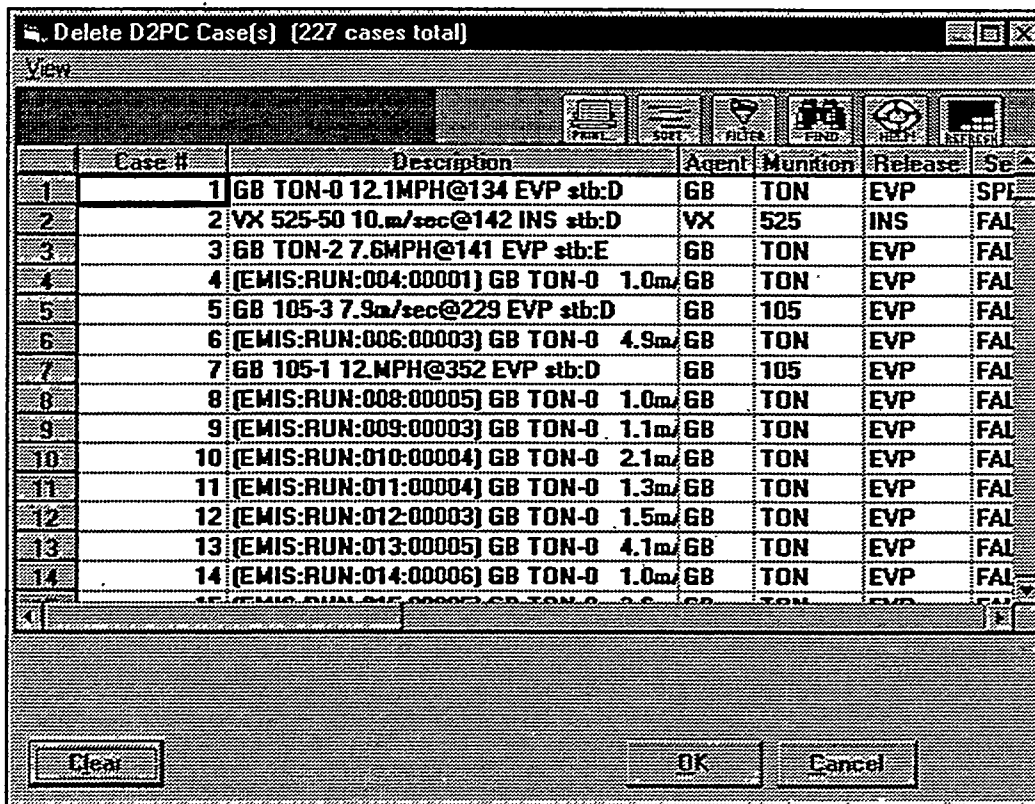

2. Select the D2PC case or cases you want to delete. If you want to delete more than one case, hold down the <Ctrl> key while you click in the row number column of the additional cases. To delete contiguous rows (cases), you can either hold down the <Shift> key while you click in the row number column of the first and last cases to be deleted or drag the cursor over the rows to select the range of cases to be deleted. Click the OK button. A message will display requesting verification of the cases to be deleted. Click the Yes button to delete, or click the No button to cancel.
3. You cannot delete the current operational case. If the case you want to delete is the current case, select a different case to be your current case; then you can delete the desired case.

9.4 Archiving D2PC Cases

If a database is accumulating a large number of D2PC cases, some of the older cases should be archived to free up database space and improve the performance of the software. The archive_d2.sh script has been written to do this. This script has two parts: 1) it does a database export of all the D2PC tables to a dump file, and 2) it deletes old D2PC cases from the database.

WARNING: Do not archive cases if you think you will need to quickly retrieve them. Running this script will write all the D2PC cases to a dump file and delete them from the database.

9.4.1 Using the archive_d2.sh Script

The archive_d2.sh script should be located in the /home/femis/database/eocdba directory along with the following support files: archive_d2.exp, archive_d2.sql, and archive_d2_n.sql. Move to the appropriate directory and start the script as shown below:

```
% cd /home/femis/database/eocdba
% archive_d2.sh
```

A menu will display the possible databases on which to perform the D2PC archive. Below is an example of what this menu would look like for Oregon/Washington. Enter the four character site code for which you want to perform D2PC archiving.

```
Databases
=====
umcd
cben
cmor
cuma
sore
swas
=====
Choice ==>
```

Then the following menu presents two options for deleting cases. If you want to delete cases older than a certain date, enter the number 1. If you wish to keep a certain number of the most recent cases, enter the number 2. Sections 9.4.2, Archiving D2PC by Date, and 9.4.3, Archiving D2PC by Number of Cases, provide details for using these options.

Note: Option 2 is not recommended for an onpost FEMIS database unless it is getting its cases from EMIS. See Section 9.4.5, Archiving Limitations, for more information.

Archive D2PC Menu

=====

- 1) Archive D2PC by date
- 2) Archive D2PC by number of cases

=====

Choice ==>

At this point, the script will export all of the D2PC database tables to a dump file with a filename form of <site code>_<year>-<month>-<day>-<hour>-<minute>_d2.dmp. For example, if the current date/time is March 6, 1997 09:11, and you are exporting from the swas database, the filename would be swas_1997-03-06-09-11_d2.dmp. If you watch during processing, a message will display with the specific filename created by this script.

Once the export has completed, you will receive the following prompt.

Did the export complete successfully? [N] ==>

If a message saying the export was terminated without warnings or errors, enter the letter Y.

From this point on, the script behaves differently based on whether you have chosen to archive by date or by the number of cases. Please see the appropriate sections for details.

9.4.2 Archiving D2PC by Date

If archiving by date, you will receive the following prompt.

Archive cases not modified in how many days? [7] ==>

If you accept the default, the script will remove any cases older than 7 days. You can change this default number of days to the number of days you want.

Note: If you have a specific date in mind and do not know how many days ago it was, you may also simply press <enter> and wait for the verification date prompt coming up next.

Next, you will be prompted for verification of the cutoff date for deleting D2PC cases. Below is an example of this prompt.

```
The date 7 days ago was 02/19/97.  
Enter archive date if date shown is incorrect (MM/DD/YY) [02/19/97] ==>
```

Once you have accepted the cutoff date for D2PC case deletion, you will be given one more chance for verification. Remember, any D2PC cases older than the displayed date will be deleted from the system. Another prompt displays the following:

```
Do you really want to delete records older than 02/19/97? [N] ==>
```

The script will then perform the D2PC deletions and return with the following message.

```
*** MSG: Archive of D2PC in <site> is complete.
```

9.4.3 Archiving D2PC by Number of Cases

If archiving by number of cases, you will be prompted for the number of cases you want to keep in the database for a particular exercise.

```
How many D2PC cases to you want to keep [1000] ==>
```

Enter any number of cases you want to keep. If you accept the default value of 1000, then all but the most recent 1000 D2PC cases for that exercise will be deleted.

You will be prompted for an exercise number on which to perform the archive:

```
What exercise number do you wish to archive? [0] ==>
```

Normal operations is exercise number 0 (zero). You can accept this number or enter another exercise number.

The script will then perform the D2PC deletions and return with the following message.

```
*** MSG: Archive of D2PC in <site> is complete
```

9.4.4 Running D2PC Archiving from the Command Line

If no command line options are specified, archive_d2.sh runs with user-interactive prompts. It is possible, however, to run the script with the following command line options.

-h will display syntax help

-n will allow you to archive all but a certain number of the most recent cases for an exercise.

-d will allow you to archive all cases older than a certain number of days.

The syntax for the **-n** option is

-n <database> <num cases> <exercise> [export dir]

<database> is the four character database code in lower case (i.e., umcd, sore, swas).

<num cases> is the number of the most recently modified cases you want to keep.

<exercise> is the exercise number for which you want to perform the archive. Exercise number 0 is normal operations.

[export dir] is an optional parameter specifying the output directory for the export dump file. If a directory is not specified, the export will be placed in your current working directory.

The following command line is an example of the **-n** option that will archive all but the most recent 55 cases found in exercise number 0 on the sore database. It will write the export file to the **/tmp/** directory

```
archive_d2.sh -n sore 55 0 /tmp/
```

The syntax for the **-d** option is

-d <database> <num days> [export dir]

<database> is the four character database code in lower case (i.e., umcd, sore, swas).

<num days> is the number days cases you wish to keep in the database. Cases older than the number of days specified will be deleted from the database.

[export dir] is an optional parameter specifying the output directory for the export dump file. If a directory is not specified, the export will be placed in your current working directory.

The following command is an example for the **-d** option that will archive all cases more than 7 days old on the sore database. It will write the export file to the **/tmp/** directory.

```
archive_d2.sh -d sore 7 /tmp/
```

9.4.5 Archiving Limitations

This archiving script deletes cases based on the XMIT_INIT_DATE found in the D2_INPUT database table. The purpose of this field is to trigger replication of information from one EOC to another, and as such, this date is only set for cases which have been marked for replication. If this date is not set, the archive script cannot tell how old the unmarked case is. In this instance, the behavior of the archive script can be unpredictable for the option to archive D2PC by number of cases. This set of circumstances should only arise for onpost databases in which users have created cases within FEMIS but have not sent them offpost via the FEMIS Tracking Navigator. Because all offpost cases are automatically replicated, the archive script should work fine for all offpost databases. Also, because all cases sent from EMIS to FEMIS are replicated, the script should also work on all onpost FEMIS databases connected to EMIS.

CAUTION

This script will archive the current operational D2PC case if it matches the criteria selected for archival.

9.5 Importing a D2PC Case

1. Select the Import Case(s) option from the File pull-down menu. An Import D2PC window similar to the following example will display.

Figure 9.5. Import D2PC Window

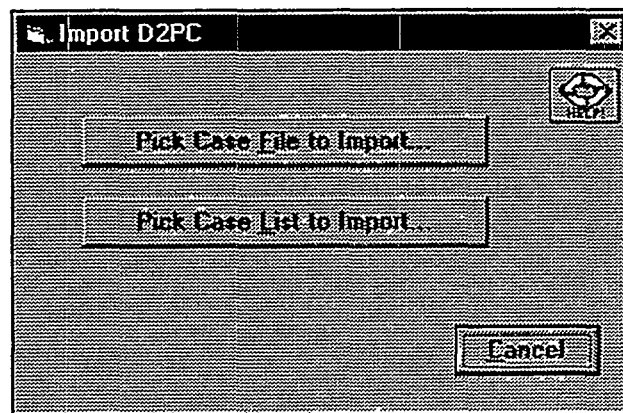

2. The two options available are
 - Pick Case File to Import to import a single case. The default extension for a D2PC Case File is .dat.

- **Pick Case List to Import to import multiple cases. Before you can import this list, you will need to create a Case List. You must use an editor and produce a file that contains the full path name for each D2PC case included in the Case List. The default list file extension is *.lst; an example filename is myd2list.lst.**

Files with other extensions can be displayed by changing the extension in the List files of type box on the Pick D2PC Case Import window.

- 3. To find the file you want to import, click on the drive and file path name until the file you want is listed. Select the file from the list, and click on the OK button.**

For more details regarding managing D2PC cases, see the FEMIS Online Help.

Appendix A
Site Survey Form

Appendix A – Site Survey Form

Because FEMIS encompasses different functionality than IBS and EMIS, some site-specific information that is essential for FEMIS is not present electronically. This type of information is obtained during the database kickoff meetings held at each site. The Site Survey form, designed by Innovative Emergency Management, Inc. (IEM) and PNNL, is used to gather this information. The surveys are tailored for each site.

An example of a Site Survey is included to indicate the types of information needed for FEMIS. This example is for the Umatilla site in Oregon.

Umatilla Site FEMIS Database Survey: Priority 1 Data, *Umatilla Chemical Depot*

INTRODUCTION

The Federal Emergency Management Information System (FEMIS) is under development by Battelle Memorial Institute, Pacific Northwest National Laboratory (PNNL). The system's purpose is to serve as the automation system in support of the Chemical Stockpile Emergency Preparedness Program (CSEPP).

The government is preparing to field FEMIS v1.2 at the Umatilla, OR site. For FEMIS to work properly at the Umatilla site, the software must have site-specific geographical data. IEM has been tasked by the government to populate a FEMIS database for the Umatilla site.

To start this task, IEM is hosting a Umatilla FEMIS database meeting at PNNL facilities on July 9, 1996. The meeting will be attended by representatives from the Umatilla jurisdictions and from PNNL. Meeting participants will generate a list of requested data for the FEMIS database. The final data list will be included in the *Umatilla FEMIS Database Meeting: After-Action Report*, to be distributed July 12.

In that report, the requested data will be ranked according to a set of priorities:

- Priority 1: These data are *required* data and must be present in the database for FEMIS to operate.
- Priority 2: These data are supporting data that are not needed for FEMIS to operate, but are *critical* to planning and response in FEMIS, and are *easy* to gather and maintain.
- Priority 3: These data are supporting data that are not needed for FEMIS to operate, and are *critical* to planning and response in FEMIS, but are *difficult* to gather or maintain.
- Priority 4: These data are supporting data that are not needed for FEMIS to operate, and are *not critical* to planning and response in FEMIS, but are *easy* to gather and maintain.
- Priority 5: These data are supporting data that are not needed for FEMIS to operate, and are *not critical* to planning and response in FEMIS, and are *difficult* to gather or maintain.

To facilitate the gathering of Priority 1 data, IEM is distributing this survey to all Umatilla jurisdictions. The survey results are needed as soon as possible, but no later than July 26, 1996, to expedite fielding of the FEMIS database. A survey for gathering data at Priority 2-5 will be provided later, based on guidance from the CSEPP Core Team.

HOW TO USE THIS SURVEY

PLEASE ANSWER THE QUESTIONS IN THIS SURVEY AS COMPLETELY AS POSSIBLE

When done, please return the survey to IEM by mail or fax. Send the survey to the attention of Todd Pierce at the following address.

Dr. Todd M. Pierce
IEM, Inc.
7423 Picardy Avenue, Suite E
Baton Rouge, LA 70808
504/767-8191 (phone)
504/767-8122 (fax)

If you need help answering any of the survey questions, please contact Todd Pierce at the same address.





PLEASE BEGIN SURVEY ON THE NEXT PAGE



EOC INFORMATION

Please review the following information about your Emergency Operating Center. This information will be used to identify your FEMIS database. Please correct any erroneous information.

1. EOC Agency Name: **Umatilla Chemical Depot**
2. EOC Code: **UMCD (for UMatilla Chemical Depot)**
(4 letters maximum)

Please review the following information about your EOC response functions. This information will be used to group tasks by function in an electronic plan in FEMIS. Please correct any erroneous information.

3. Listed below are the emergency support functions for response that are currently in FEMIS. Please review the list and perform the following actions:

- A. Delete any unneeded functions by drawing a line through the function in column A, *FUNCTION*.
- B. Edit a function by drawing a line through the function and writing the new function next to the old one in column B, *EDIT FUNCTION*.
- C. List any new functions by writing them in column C, *NEW FUNCTIONS*.

A. FUNCTION	B. EDIT FUNCTION	C. NEW FUNCTIONS
Alert Notification		
Communications		
Damage Assessment		
Direction Control		
Energy		
EOC Activation		
Evacuation		
Firefighting		
Food		
Hazard Analysis		
Hazardous Materials		
Health and Medical Services		
Information and Planning		
Law Enforcement		
Mass Care		
Public Information		
Public Works and Engineering		
Resource Support		
Sheltering		
Transportation		
Urban Search and Rescue		



EMERGENCY PLANNING ZONES

Please answer the following question about your Emergency Planning Zones. This information will be used when you make a Protective Action Decision in FEMIS.

4. Which Emergency Planning Zones (EPZs) are your EOC responsible for? In other words, what are the EPZs for which your EOC can make a Protective Action Decision (PAD)? Please list them below.

EMERGENCY PLANNING ZONES FOR YOUR EOC

--	--



PLEASE TURN PAGE TO BEGIN NEXT SECTION.



EOC POSITIONS

Please review the following information about your EOC positions. This information will be used when creating the FEMIS personnel database. Please correct any erroneous information.

5. Listed below are the EOC positions currently in FEMIS. Please review the list and perform the following actions:

- A. Delete any unneeded positions by drawing a line through the position in column A, *EOC POSITION*.
- B. Edit a position by drawing a line through the position and writing the new position next to the old one in column B, *EDIT EOC POSITION*.
- C. Add any new positions by writing them in column C, *NEW EOC POSITION*.

A. EOC POSITION	B. EDIT EOC POSITION	C. NEW EOC POSITION
Accounting Personnel		
Administration Clerk		
Administration Officer		
Agriculture Department Representative		
Ammunition Branch Representative		
Assistant EOC Coordinator/Director		
Automation System Manager		
Auditor		
Chemical Accident or Incident Control Officer		
Casualty Coordinator		
Chemical Changehouse Operator		
Chart Control Operator		
Chemical Lab Representative		
Chemical Operations Director		
Chief Plotter		
City Government Representative		
Civil Defense Director		
Claims Officer		
Communications Coordinator		
Communications Representative		
Command Post Officer		
Community Affairs Representative		
Chemical Containment Team Representative		
County Government Representative		
CSEPP Coordinator		
Deputy Director of Operations		
Depot Commander		
Department of Environmental Quality Representative		
Director of Operations		
Dispatcher		
Department of Natural Resources Representative		



A. EOC POSITION	B. EDIT EOC POSITION	C. NEW EOC POSITION
Emergency Aid Organization Representative		
Emergency Medical Personnel		
Emergency Team Captain		

A. EOC POSITION	B. EDIT EOC POSITION	C. NEW EOC POSITION
EMIS System Manager		
Engineering Assistant		
Environmental Branch Representative		
EOC Coordinator		
EOC Coordinator/Director		
EOC Operations Officer		
Environmental Protection Agency Representative		
Equipment Coordinator		
Evacuation Coordinator		
Exercise Controller		
Exercise Evaluator		
Explosive Ordnance Disposal Representative		
Facilities Coordinator		
Federal Emergency Management Agency Representative		
Fire Protection/Prevention Representative		
Governor's Representative		
Hazard Analyst/Modeler		
Hazard Plotter		
Health Department Representative		
Human Resource Coordinator		
Information Systems Command Representative		
Information Coordinator/Manager		
Insurance Commission Representative		
Inventory Management Representative		
Initial Response Force (IRF) Commander		
Law Enforcement Representative		
Legal Counselor		
Legal Officer		
Logistics Director/Officer		
Medical Facility Representative		
Message Controller		
Military Affairs Representative		
Monitoring Team Coordinator		
National Guard Coordinator		
On-Scene Coordinator (OSC)		
Operations Analyst		



A. EOC POSITION	B. EDIT EOC POSITION	C. NEW EOC POSITION
Operations Officer		
Personnel Coordinator		
Planner		
Production and Planning Control Representative		
Plotter		
Post Sergeant Major		

A. EOC POSITION	B. EDIT EOC POSITION	C. NEW EOC POSITION
Public Information/Public Affairs Officer		
Public Information Coordinator		
Public Safety Representative		
Public Works/Infrastructure Representative		
Quality Assurance Representative		
Radio Operator		
Recorder		
Records Section Representative		
Report Coordinator		
Resource Coordinator		
Resource Management Officer		
Safety Representative		
Sampling Specialist		
School Superintendent		
Security Guard		
Security/Intelligence Officer		
Shelter Coordinator		
Social Services Representative		
Special Population Coordinator		
Service Response Force Commander (SRF)		
State Coordinating Officer		
State Emergency Management Director		
State Emergency Management Liaison		
Storage Section Representative		
Surety Officer		
Training Officer		
Transportation/Highway Department Representative		



PLEASE TURN PAGE TO BEGIN NEXT SECTION.



RESOURCE CATEGORIES

Please review the following information about resource categories. This information will be used when creating the FEMIS resource database. Please correct any erroneous information.

6. Listed below are the resource categories currently in FEMIS. Please review the list and perform the following actions:

- A. Delete any unneeded categories by drawing a line through the position in column A, *RESOURCE CATEGORY*.
- B. Edit a category by drawing a line through the category and writing the new category next to the old one in column B, *EDIT RESOURCE CATEGORY*.
- C. Add any new categories by writing them in column C, *NEW RESOURCE CATEGORY*.

A. RESOURCE CATEGORY	B. EDIT RESOURCE CATEGORY	C. NEW RESOURCE CATEGORY
Barricades		
Cars		
Communication Equipment		
Construction Equipment		
Dry Goods		
Emergency Equipment		
First Aid Supplies		
Food		
Generators		
Hand Tools		
Heavy Equipment		
Lights		
Medical Equipment		
Office Machines		
Paving Equipment		
People		
Power Tools		
Prefabricated Buildings		
Rescue Squad		
Scales		
Siren-Non-rotating		
Siren-Rotating		
Transport Vehicles		
Trucks		
Water		
Weapons		



PLEASE TURN PAGE TO BEGIN NEXT SECTION.



ACCIDENT CATEGORIES

Please answer the following question about your accident categories. This information will be used when creating the FEMIS map database.

7. Please list below the accident categories for your site. For each category, please indicate the range of downwind No Effects distances (for example, from 0 km to 2 km, or 2 km to 6 km). Add more categories if needed.

Category I	Downwind No Effects distance from	km to	km
Category II	Downwind No Effects distance from	km to	km
Category III	Downwind No Effects distance from	km to	km
Category IV	Downwind No Effects distance from	km to	km
Category V	Downwind No Effects distance from	km to	km
Category	Downwind No Effects distance from	km to	km
Category	Downwind No Effects distance from	km to	km

FACILITIES

Please answer the following question about your facilities. This information will be used when creating the FEMIS facilities database.

8. Use the attached Table 1 to list basic information about facilities you would like to have in your FEMIS facilities database. For the Priority 1 data, IEM needs only the following information:

- A. Facility Name
- B. Facility Address
- C. Latitude and Longitude (if known)
- D. EPZ Containing the Facility

You may also provide this information electronically in a word processor or spreadsheet format, if desired.

If you have more facilities than can fit in Table 1, please make extra copies of Table 1.

Further facility information would be gathered as Priority 2 data.

CONTACT INFORMATION

Please provide the requested contact information.

9. Name of Person Who Completed This Survey: _____

10. Phone # of Person Who Completed This Survey: _____





**YOU HAVE NOW COMPLETED THIS SURVEY.
THANK YOU FOR YOUR TIME**



Appendix B
FEMIS Database Changes

Appendix B – FEMIS Database Changes

The FEMIS database consists of the Oracle relational database and the GIS data.

Oracle Database Schema Changes

The following list details all the Oracle database schema changes that have been implemented to update the database from FEMIS v1.4.5 to the current version, FEMIS v1.4.6.

Table Name	Column Name/Definition	Description of Change
AGENCY	BEEPER_PHONE	Added column to table. Defined as VARCHAR2(30).
AGENCY	CEL_PHONE	Added column to table. Defined as VARCHAR2(30).
AGENCY	CITY_NAME	Added column to table. Defined as VARCHAR2(20).
AGENCY	EMAIL_ADDRESS	Added column to table. Defined as VARCHAR2(80).
AGENCY	EMAIL_ADDRESS2	Added column to table. Defined as VARCHAR2(80).
AGENCY	FAX_PHONE	Added column to table. Defined as VARCHAR2(30).
AGENCY	MAIN_PHONE	Added column to table. Defined as VARCHAR2(30).
AGENCY	STATE_CODE	Added column to table. Defined as VARCHAR2(2).
AGENCY	STREET_ADDRESS1	Added column to table. Defined as VARCHAR2(40).
AGENCY	STREET_ADDRESS2	Added column to table. Defined as VARCHAR2(40).
AGENCY	WEB_ADDRESS	Added column to table. Defined as VARCHAR2(255).
AGENCY	ZIP_CODE	Added column to table. Defined as VARCHAR2(10).
BTB_PLAN_DETAIL	RESPONSIBLE_AGENCY	Changed column definition to NUMBER(9).
BTB_PLAN_DETAIL	RESPONSIBLE_DEPT	Changed column definition to NUMBER(9).
BTB_PLAN_HEADER	HAZARD_ID	Added column to table. Defined as NUMBER(9).
BTB_RESOURCE_ASSIGNMENT	PLAN_POC_AGENCY	Changed column definition to NUMBER(9).

Table Name	Column Name/Definition	Description of Change
BTB_RESOURCE_ASSIGNMENT	PLAN_POC_DEPT	Changed column definition to NUMBER(9).
CAS_INQUIRY	INFO_REQUESTED	Added column to table. Defined as VARCHAR2(255).
CAS_INQUIRY	INFORMATION_REQUESTED	Dropped column.
CAS_INQUIRY	INQ_NAME	Added column to table. Defined as VARCHAR2(40).
CAS_INQUIRY	INQ_TK_REF_NUM	Added column to table. Defined as NUMBER(9). Part of the FOREIGN KEY on the TRACKED_PERSON table.
CAS_INQUIRY	INQUIRY_ID	Added column to table. Defined as NUMBER(9). N PRIMARY KEY.
CASE_LINK		Dropped table. Dropped CASE_LINK sequence.
CASUALTY	EOC_NAME	Added column to table. Defined as VARCHAR2(30).
CASUALTY	VICTIM_AGENCY_CODE	Changed column definition to NUMBER(9).
CASUALTY	VICTIM_PERSON_REF_NUM	Dropped column.
CONTROL_POINT		Updated table data. Mostly from the CONTROL_POINT table.
CONTROL_POINT	CP_NAME	Lengthened to VARCHAR2(60).
CONTROL_POINT	CP_TYPE	Added column to table. Defined as VARCHAR2(30).
CONTROL_POINT	HAZARD_ID	Added column to table. Defined as NUMBER(9).
CONTROL_POINT	XMIT_INIT_DATE	Added column to table. Defined as DATE.
CSEPP_ACCIDENT	UPDATE_USER_CODE	Added column to table. Defined as VARCHAR2(8)
CSEPP_ACCIDENT	UPDATE_USER_NAME	Added column to table. Defined as VARCHAR2(48).
D2_INPUT	D2_I_AS_CLDCOV	Added column to table. Defined as NUMBER(2,0).
D2_INPUT	D2_I_AS_CLDCOV_SRC	Added column to table. Defined as VARCHAR2(1).
D2_INPUT	D2_I_AS_CLDHT	Added column to table. Defined as NUMBER(8,2).
D2_INPUT	D2_I_AS_CLDHT_SRC	Added column to table. Defined as VARCHAR2(1).

Table Name	Column Name/Definition	Description of Change
D2_INPUT	D2_I_AS_METPOL	Added column to table. Defined as NUMBER(6,1).
D2_INPUT	D2_I_AS_METPOL_SRC	Added column to table. Defined as VARCHAR2(1).
D2_INPUT	D2_I_AS_SOLRAD	Added column to table. Defined as NUMBER(7,2).
D2_INPUT	D2_I_AS_TGRADH	Added column to table. Defined as NUMBER(8,4).
D2_INPUT	D2_I_AS_TGRADL	Added column to table. Defined as NUMBER(8,4).
D2_INPUT	D2_I_AS_WSIG	Added column to table. Defined as NUMBER(9,2).
D2_INPUT	D2_I_AS_WSPD	Added column to table. Defined as NUMBER(6,3).
D2_INPUT	D2_I_AUTO_STB	Added column to table. Defined as VARCHAR2(1).
D2_INPUT	D2_I_CLS_AS_CLOUD	Added column to table. Defined as NUMBER(2,0).
D2_INPUT	D2_I_CLS_AS_SOLRAD	Added column to table. Defined as NUMBER(2,0).
D2_INPUT	D2_I_CLS_AS_TGRADH	Added column to table. Defined as NUMBER(2,0).
D2_INPUT	D2_I_CLS_AS_TGRADL	Added column to table. Defined as NUMBER(2,0).
D2_INPUT	D2_I_CLS_AS_WSIG	Added column to table. Defined as NUMBER(2,0).
D2_INPUT	D2_I_CLS_AS_WSPD	Added column to table. Defined as NUMBER(2,0).
D2_INPUT	D2_I_HTUSED	Added column to table. Defined as NUMBER(3).
D2_INPUT	D2_I_TMP_GRND_SRC	Added column to table. Defined as VARCHAR2(1).
D2_INPUT	D2_I_TWR_AS_CLOUD	Added column to table. Defined as VARCHAR2(9).
D2_INPUT	D2_I_TWR_AS_SOLRAD	Added column to table. Defined as VARCHAR2(9).
D2_INPUT	D2_I_TWR_AS_TGRAD	Added column to table. Defined as VARCHAR2(9).
D2_INPUT	D2_I_TWR_AS_WSIG	Added column to table. Defined as VARCHAR2(9).

Table Name	Column Name/Definition	Description of Change
D2_INPUT	D2_I_TWR_AS_WSPD	Added column to table. Defined as VARCHAR2(9).
D2_INPUT	D2_I_WEDGE_ANGLE	Added column to table. Defined as NUMBER(3).
D2_MET_SELECTION		Created a FOREIGN KEY to the MET_CONDITION table.
DEPARTMENT	BEEPER_PHONE	Added column to table. Defined as VARCHAR2(30).
DEPARTMENT	CEL_PHONE	Added column to table. Defined as VARCHAR2(30).
DEPARTMENT	EMAIL_ADDRESS	Added column to table. Defined as VARCHAR2(80).
DEPARTMENT	EMAIL_ADDRESS2	Added column to table. Defined as VARCHAR2(80).
DEPARTMENT	FAX_PHONE	Added column to table. Defined as VARCHAR2(30).
DEPARTMENT	MAIN_PHONE	Added column to table. Defined as VARCHAR2(30).
DEPARTMENT	WEB_ADDRESS	Added column to table. Defined as VARCHAR2(255).
DEPT_EOC		Dropped table.
EOC_OBJECTIVE	D2PC_EVENT_DELTA_MINUTES	Added D2PC_EVENT_DELTA_MINUTES to table. Defined as NUMBER(5).
EOC_ZONE	POLYGONAL_LAYER_ID	Added column to table. Defined as NUMBER(9). Part of the PRIMARY KEY. Also part of a FOREIGN KEY for the ZONE table.
EV_INQUIRY	EV_REL_PERSON_REF_NUM	Change name from EV_REL_PERSON_REF_NUM to REL_PERSON_REF_NUM.
EV_INQUIRY	INFO_NOTES	Changed Name from EV_INFO_NOTES to INFO_NOTES. Lengthened the column to 2000.
EV_INQUIRY	INFO_RELEASED_FLAG	Changed name from EV_INFO_RELEASED_FLAG to INFO_RELEASED_FLAG.
EV_INQUIRY	INFO_REQUESTED	Changed Name from EV_INFORMATION_REQUESTED to INFO_REQUESTED. Lengthened the column to 255.
EV_INQUIRY	INFO_REQUESTED_FLAG	Changed name from EV_INFO_REQUESTED_DATE to INFO_REQUESTED_DATE.

Table Name	Column Name/Definition	Description of Change
EV_INQUIRY	INQUIRY_ID	Added INQUIRY_ID to table. Defined as NUMBER(9). INQUIRY_ID replaces INQ_TK_REF_NUM as part of the PRIMARY KEY.
EXERCISE_CONTROL	EOC_NAME	Added column to table. Defined as VARCHAR2(30). Part of the PRIMARY KEY.
EXERCISE_CONTROL	EXERCISE_DATA_DATE	Dropped column.
EXERCISE_CONTROL	EXERCISE_DATA_NAME	Dropped column.
EXERCISE_CONTROL	EXERCISE_DESCRIPTION	Added column to table. Defined as VARCHAR2(127).
EXERCISE_CONTROL	EXERCISE_LONG_DESCRIPT	Added column to table. Defined as VARCHAR2(2000).
EXERCISE_CONTROL	EXERCISE_NAME	Dropped column.
EXERCISE_CONTROL	XMIT_INIT_DATE	Added column to table. Defined as DATE.
FACILITY	BEEPER_PHONE	Added column to table. Defined as VARCHAR2(30).
FACILITY	CEL_PHONE	Added column to table. Defined as VARCHAR2(30).
FACILITY	EMAIL_ADDRESS	Added column to table. Defined as VARCHAR2(80).
FACILITY	EMAIL_ADDRESS2	Added column to table. Defined as VARCHAR2(80).
FACILITY	FACILITY_POC_AGENCY	Changed column definition to NUMBER(9).
FACILITY	FACILITY_POC_DEPT	Changed column definition to NUMBER(9).
FACILITY	FACILITY_POC_POSITION	Changed column definition to NUMBER(9).
FACILITY	FAX_PHONE	Added column to table. Defined as VARCHAR2(30).
FACILITY	MAIN_PHONE	Added column to table. Defined as VARCHAR2(30).
FACILITY	MUTUAL_AID_FLAG	Dropped column.
FACILITY	WEB_ADDRESS	Added column to table. Defined as VARCHAR2(255).
G_DEF_COMMUNITY		Added new table.
G_DEF_COMMUNITY_VAL		Added new table.
G_DEF_EMERGENCY		Added new table.
G_DEF_EMERGENCY_LEVELS		Added new table.

Table Name	Column Name/Definition	Description of Change
G_DEF_HAZARD_CLASS		Added new table.
G_DEF_NAV_BUTTON		Added new table.
G_DEF_NAV_FUNCTION		Added new table.
G_DEF_NAV_FUNCTION_IO		Added new table.
G_DEF_PAD_LABELS		Added new table.
G_EMERGENCY		Added new table.
G_NAVIGATOR_ITEM		Added new table.
GENERIC_TEXT	EOC_NAME	Added column to table. Defined as VARCHAR2(30).
GENERIC_TEXT	GENERIC_TEXT_ID	Added column to table. Defined as NUMBER(9) NOT NULL. Part of the PRIMARY KEY.
GENERIC_TEXT	HAZARD_ID	Added column to table. Defined as NUMBER(9).
GEO_OBJECT		Added new table.
GEO_OBJECT_ZONE		Added table.
GIS_LAYER		Updated table data.
GIS_LAYER		Updated table data.
GIS_LAYER		Updated table data.
GIS_LAYER	CLASSIFICATION_FIELD	Added column to table. Defined as VARCHAR2(20).
GIS_LAYER	DEFAULT_LEGEND_TYPE	Added column to table. Defined as VARCHAR2(8).
GIS_LAYER	DYNAMIC_LAYER_FLAG	Added column to table. Defined as VARCHAR2(1). Column constraint - the value must equal Y.
GIS_LAYER	EOC_NAME	Added EOC_NAME to table and defined it as a Foreign Key to the EOC table. Defined as VARCHAR2(30).
GIS_LAYER	EXERCISE_NUM	Added column to table. Defined as NUMBER(9) NOT NULL. Part of the PRIMARY KEY.
GIS_LAYER	GIS_LAYER_FILE_PATH	Added column to table. Defined as VARCHAR2(32).
GIS_LAYER	GIS_LAYER_FILL_PATTERN	Dropped column.
GIS_LAYER	GIS_LAYER_LINE_STYLE	Dropped column.
GIS_LAYER	GIS_LAYER_POINT_SYMBOL	Dropped column.
GIS_LAYER	GIS_LAYER_SYMBOL_ID	Added column to table. Defined as NUMBER(3).

Table Name	Column Name/Definition	Description of Change
GIS_LAYER	HAZARD_ZONE_LAYER_FLAG	Added column to table. Defined as VARCHAR2(1).
GIS_LAYER	LABEL_FIELD	Added column to table. Defined as VARCHAR2(20).
GIS_LAYER	LENGEND_ORDER	Added column to table. Defined as NUMBER(9,2).
GIS_LAYER	LOAD_FLAG	Added column to table. Defined as VARCHAR2(1).
GIS_LAYER	MAXIMUM_SCALE	Added column to table. Defined as NUMBER(9).
GIS_LAYER	MINIMUM_SCALE	Added column to table. Defined as NUMBER(9).
GIS_LAYER	OBJ_LOOKUP_CATEGORY	Added column to table. Defined as VARCHAR2(20).
GIS_LAYER	VISIBLE_FLAG	Added column to table. Defined as VARCHAR2(1).
GIS_THEME_DATA		Added new table.
HAZARD		Dropped table.
INTERVAL_QUANTITY	QUANTITY_PER_INTERVAL_SRC	Added column to table. Defined as CHAR(1).
JOURNAL	HAZARD_ID	Added column to table. Defined as NUMBER(9).
KNOWN_POINT	CREATION_DATE	Dropped column.
KNOWN_POINT	LAST_CHANGE_PERSON	Added column to table. Defined as VARCHAR2(40) NOT NULL.
KNOWN_POINT	POC	Added column to table. Defined as VARCHAR2(255).
KNOWN_POINT	POC_AGENCY_NAME	Dropped column.
KNOWN_POINT	TRANSMIT_DATA	Dropped column.
KNOWN_POLYGON	EOC_NAME	Added column to table. Defined as VARCHAR2(30) NOT NULL. FOREIGN KEY to the EOC table.
KNOWN_POLYGON	KP_SUB_CLASS_REF_ID	Added column to table. Defined as NUMBER(9) NOT NULL. Part of the FOREIGN KEY to the KP_SUB_CLASS_DEF table.
KNOWN_POLYGON	KPOLY_DESCRIPTION	Added column to table. Defined as VARCHAR2(255).
KNOWN_POLYGON	KPOLY_NAME	Added column to table. Defined as VARCHAR(30) NOT NULL.

Table Name	Column Name/Definition	Description of Change
KNOWN_POLYGON	KPOLY_REF_ID	Added column to table. Defined as NUMBER(9) NOT NULL. Part of the PRIMARY KEY.
KNOWN_POLYGON	LAST_CHANGE_DATE	Added column to table. Defined as DATE NOT NULL.
KNOWN_POLYGON	LAST_CHANGE_PERSON	Added column to table. Defined as VARCHAR2(40) NOT NULL.
KNOWN_POLYGON	NOTES	Added column to table. Defined as VARCHAR2(2000).
KNOWN_POLYGON	POC	Added column to table. Defined as VARCHAR2(255).
KNOWN_POLYGON	POLYGON_DESCRIPTION	Dropped column.
KNOWN_POLYGON	POLYGON_NAME	Dropped column.
KNOWN_POLYGON	STATUS_1	Added column to table. Defined as VARCHAR2(32).
KNOWN_POLYGON	STATUS_2	Added column to table. Defined as VARCHAR2(32).
KNOWN_POLYGON	STATUS_3	Added column to table. Defined as VARCHAR2(32).
KNOWN_POLYGON	STATUS_4	Added column to table. Defined as VARCHAR2(32).
KNOWN_POLYGON	STATUS_5	Added column to table. Defined as VARCHAR2(32).
KNOWN_POLYGON	XMIT_INIT_DATE	Added column to table. Defined as DATE.
KP_CLASS_DEF	CLASS_NOTES	Added column to table. Defined as VARCHAR2(2000).
KP_CLASS_DEF	DEFAULT_POC	Added column to table. Defined as VARCHAR2(255).
KP_CLASS_DEF	EDIT_FLAG	Added column to table. Defined as CHAR(1).
KP_CLASS_DEF	EOC_NAME	Added column to table. Defined as VARCHAR2(30) NOT NULL. FOREIGN KEY to the EOC table.
KP_CLASS_DEF	FEATURE_TYPE	Added column to table. Defined as VARCHAR2(30) NOT NULL.
KP_CLASS_DEF	LAST_CHANGE_DATE	Added column to table. Defined as DATE NOT NULL.
KP_CLASS_DEF	LAST_CHANGE_PERSON	Added column to table. Defined as VARCHAR2(40) NOT NULL.
KP_CLASS_DEF	PERMANENT_CLASS	Dropped column.
KP_CLASS_DEF	STATUS_1_LABEL	Added column to table. Defined as VARCHAR2(16).

Table Name	Column Name/Definition	Description of Change
KP_CLASS_DEF	STATUS_1_TYPE	Added column to table. Defined as VARCHAR2(32).
KP_CLASS_DEF	STATUS_2_LABEL	Added column to table. Defined as VARCHAR2(16).
KP_CLASS_DEF	STATUS_2_TYPE	Added column to table. Defined as VARCHAR2(32).
KP_CLASS_DEF	STATUS_3_LABEL	Added column to table. Defined as VARCHAR2(16).
KP_CLASS_DEF	STATUS_3_TYPE	Added column to table. Defined as VARCHAR2(32).
KP_CLASS_DEF	STATUS_4_LABEL	Added column to table. Defined as VARCHAR2(16).
KP_CLASS_DEF	STATUS_4_TYPE	Added column to table. Defined as VARCHAR2(32).
KP_CLASS_DEF	STATUS_5_LABEL	Added column to table. Defined as VARCHAR2(16).
KP_CLASS_DEF	STATUS_5_TYPE	Added column to table. Defined as VARCHAR2(32).
KP_CLASS_DEF	TRANSMIT_DATA	Dropped column.
KP_HISTORY		Dropped table.
KP_SUB_CLASS_DEF KP_CLASS_DEF KNOWN_POINT		Updated table data. Mostly from the KP_SUB_CLASS_DEF, KP_CLASS_DEF, and KNOWN_POINT tables.
KP_SUB_CLASS_DEF KP_CLASS_DEF		Updated flags in KP_SUB_CLASS_DEF and KP_CLASS_DEF tables.
KP_SUB_CLASS_DEF	DEFAULT_AGENCY	Dropped column.
KP_SUB_CLASS_DEF	EDIT_FLAG	Added column to table. Defined as CHAR(1).
KP_SUB_CLASS_DEF	EOC_NAME	Added column to table. Defined as VARCHAR2(30) NOT NULL. FOREIGN KEY to the EOC table.
KP_SUB_CLASS_DEF	GIS_LAYER_NAME	Added column to table. Defined as VARCHAR2(30).
KP_SUB_CLASS_DEF	LAST_CHANGE_DATE	Added column to table. Defined as DATE NOT NULL.
KP_SUB_CLASS_DEF	LAST_CHANGE_PERSON	Added column to table. Defined as VARCHAR2(40) NOT NULL.
KP_SUB_CLASS_DEF	PERMANENT_SUBCLASS	Dropped column.
KP_SUB_CLASS_DEF	STATUS_1_LABEL	Dropped column.
KP_SUB_CLASS_DEF	STATUS_1_TYPE	Dropped column.
KP_SUB_CLASS_DEF	STATUS_2_LABEL	Dropped column.

Table Name	Column Name/Definition	Description of Change
KP_SUB_CLASS_DEF	STATUS_2_TYPE	Dropped column.
KP_SUB_CLASS_DEF	STATUS_3_LABEL	Dropped column.
KP_SUB_CLASS_DEF	STATUS_3_TYPE	Dropped column.
KP_SUB_CLASS_DEF	STATUS_4_LABEL	Dropped column.
KP_SUB_CLASS_DEF	STATUS_4_TYPE	Dropped column.
KP_SUB_CLASS_DEF	STATUS_5_LABEL	Dropped column.
KP_SUB_CLASS_DEF	STATUS_5_TYPE	Dropped column.
KP_SUB_CLASS_DEF	SUB_CLASS_TYPE	Dropped column.
KP_SUB_CLASS_DEF	TRANSMIT_DATA	Dropped column.
LINK_TYPE		Dropped table
LOCAL_CONFIG	CURRENT_WORK_PLAN_DATE	Added column to table. Defined as DATE.
LOCAL_CONFIG	CURRENT_WORK_PLAN_USER	Added column to table. Defined as VARCHAR2(8).
LOCAL_CONFIG	CURRENT_WPA_DATE	Dropped column.
LOCAL_CONFIG	CURRENT_WPA_ID	Dropped column.
LOCAL_CONFIG	CURRENT_WPA_USER	Dropped column.
LOCAL_CONFIG	CURRNET_WORK_PLAN_ID	Added column to table. Defined as NUMBER(9).
MEMO_UNDERSTANDING	MOU_DESCRIPTION	Lengthened column to VARCHAR2(255).
MEMO_UNDERSTANDING	MOU_POC_AGENCY	Changed column definition to NUMBER(9).
MEMO_UNDERSTANDING	MOU_POC_DEPT	Changed column definition to NUMBER(9).
MEMO_UNDERSTANDING	MOU_POC_POSITION	Changed column definition to NUMBER(9).
MET_CLUSTER		Created table.
MET_CONDITION		Created a FOREIGN KEY to the MET_CLUSTER table.
MET_CONDITION	CLUSTER_HEIGHT	Dropped column.
MET_CONDITION	WIND_SIGMA	Added column to table. Defined as NUMBER(9,2).
NEXT_OF_KIN	EV_NOK_NOTIFY_FLAG	Added column to table. Defined as VARCHAR2(1).
NEXT_OF_KIN	NOK_COMMENT	Lengthened column to VARCHAR2(255).
PA_DECISION_MATRIX	HAZARD_ID	Added column to table. Defined as NUMBER(9).
PA_DECISION_MATRIX	PA_ACTIVITY	Dropped column.

Table Name	Column Name/Definition	Description of Change
PA_DECISION_MATRIX	PROT_ACT_INDEX	Added column to table. Defined as NUMBER(2).
PA_LOOKUP	HAZARD_ID	Added column to table. Defined as NUMBER(9). Part of the PRIMARY KEY.
PA_LOOKUP	PA_ACTIVITY	Dropped column.
PA_LOOKUP	PA_TASK_NAME	Dropped column.
PA_LOOKUP	PROT_ACT_INDEX	Added column to table. Defined as NUMBER(2). Part of the PRIMARY KEY.
PA_UNIT		Added a FOREIGN KEY to the FACILITY table.
PA_UNIT	POLYGONAL_LAYER_ID	Added column to table. Defined as NUMBER(9) NOT NULL. Also a FOREIGN KEY for the ZONE table.
PERSON	CEL_PHONE	Added column to table. Defined as VARCHAR2(30).
PERSON	EMAIL_ADDRESS2	Added column to table. Defined as VARCHAR2(80).
PERSON	POSITION_TITLE	Dropped column.
PERSON	WEB_ADDRESS	Added column to table. Defined as VARCHAR2(255).
PERSON	WK_POSITION_ID	Added column to table. Defined as NUMBER(9). Part of the FOREIGN KEY to the WK_POSITION table.
PERSON	WK_POSITION_ID	Added column to table. Defined as NUMBER(9).
PERSON_SHELTERED	EOC_NAME	Added column to table. Defined as VARCHAR2(30).
PERSON_SHELTERED	EV_NOTES	Lengthen to 2000 characters.
PERSON_SHELTERED	NOK_NOTIFY_FLAG	Added column to table. Defined as VARCHAR2(1). Column constraint - the value must equal Y or N.
PERSON_SHELTERED	POST_EV_PHONE	Lengthen to 30 characters.
PERSON_SHELTERED	SP_MEDICAL_NEEDS	Lengthen to 2000 characters.
PLAN_DETAIL	RESPONSIBLE_AGENCY	Changed column definition to NUMBER(9).
PLAN_DETAIL	RESPONSIBLE_DEPT	Changed column definition to NUMBER(9).
PLAN_HEADER	HAZARD_ID	Added column to table. Defined as NUMBER(9).
POLYGONAL_LAYER		Create table. Has a FOREIGN KEY for the GIS_LAYER table.

Table Name	Column Name/Definition	Description of Change
POLYGONAL_LAYER	EOC_NAME	Added EOC_NAME to table and defined it as a Foreign Key to the EOC table. Defined as VARCHAR2(30).
POPULATION_CONDITION		Dropped table.
POPULATION_DEFINITION		Dropped table.
POPULATION_FLUX		Dropped table.
POPULATION_LOCATION		Dropped table.
POSITION	POSITION_DESCRIPTION	Lengthen to 255 characters.
POSITION	POSITION_PHONE	Lengthen to 30 characters.
POSITION_PRIV	CP_NAME	Lengthened to VARCHAR2(60).
POTENTIAL_ACCIDENT	EOC_NAME	Added EOC_NAME to table and defined it as a Foreign Key to the EOC table. Defined as VARCHAR2(30).
POTENTIAL_ACCIDENT	LID_DIRECTION_FROM_IGLOO	Added column to table. Defined as VARCHAR2(2).
POTENTIAL_ACCIDENT	LID_DISTANCE_FROM_IGLOO	Added column to table. Defined as NUMBER(8,2).
POTENTIAL_ACCIDENT	LID_EOC_NAME	Added column to table. Defined as VARCHAR2(30).
POTENTIAL_ACCIDENT	LID_IGLOO	Added column to table. Defined as VARCHAR2(30).
POTENTIAL_ACCIDENT	LID_LATITUDE	Added column to table. Defined as NUMBER(12,6).
POTENTIAL_ACCIDENT	LID_LONGITUDE	Added column to table. Defined as NUMBER(12,6).
POTENTIAL_THREAT	EOC_NAME	Added column to table. Defined as VARCHAR2(30).
POTENTIAL_THREAT	HAZARD_ID	Added column to table. Defined as NUMBER(9).
PRIVILEGE	CP_NAME	Lengthened to VARCHAR2(60).
PRIVILEGE	HAZARD_ID	Added column to table. Defined as VARCHAR2(30).
PRIVILEGE	USE_FLAG	Dropped column.
PRIVILEGE	XMIT_INIT_DATE	Added column to table. Defined as DATE.
PROGRAM_LOCK	LOCK_PROGRAM	Lengthened column to VARCHAR2(40).
PROTECTIVE_ACTION	HAZARD_ID	Added column to table. Defined as NUMBER(9). Part of the PRIMARY KEY.
PROTECTIVE_ACTION	PA_ACTIVITY	Dropped column.
PROTECTIVE_ACTION	PA_DESCRIPTION	Dropped column.

Table Name	Column Name/Definition	Description of Change
PROTECTIVE_ACTION	PROT_ACT_ABBREV	Added column to table. Defined as VARCHAR2(16).
PROTECTIVE_ACTION	PROT_ACT_DESC	Added column to table. Defined as VARCHAR2(127).
PROTECTIVE_ACTION	PROT_ACT_INDEX	Added column to table. Defined as NUMBER(2). Part of the PRIMARY KEY.
PROTECTIVE_ACTION	PROT_ACT_NAME	Added column to table. Defined as VARCHAR2(60).
PROTECTIVE_ACTION	XMIT_INIT_DATE	Added column to table. Defined as DATE.
RELEASE	HEIGHT_OF_SOURCE_SRC	Added column to table. Defined as VARCHAR2(1).
RELEASE	QUANTITY_PER_RELEASE_SRC	Added column to table. Defined as VARCHAR2(1).
RELEASE	SIGMA_X_SRC	Added column to table. Defined as VARCHAR2(1).
RELEASE	SIGMA_Y_SRC	Added column to table. Defined as VARCHAR2(1).
RELEASE	SIGMA_Z_SRC	Added column to table. Defined as VARCHAR2(1).
RELEASE	SOURCE_QUANTITY_IND	Dropped column.
RELEASE	TIME_AFTER_FUNCT_SRC	Added column to table. Defined as VARCHAR2(1).
RESOURCE_ASSIGNMENT	PLAN_POC_AGENCY	Changed column definition to NUMBER(9).
RESOURCE_ASSIGNMENT	PLAN_POC_DEPT	Changed column definition to NUMBER(9).
RESOURCE_OWNER	RESOUCRE_POC_POSITION	Changed column definition to NUMBER(9).
RESOURCE_OWNER	RESOURCE_POC_DEPT	Changed column definition to NUMBER(9).
RESOURCE_OWNER	RESOURCE_POS_AGENCY	Changed column definition to NUMBER(9).
SHELTER		Added a FOREIGN KEY to the FACILITY table.
SHELTER	EOC_NAME	Added column to table. Defined as VARCHAR2(30).
SHELTER	SHELTER_DESCRIPTION	Lengthen to 255 characters.
SITUATION_SUMMARY	COMBO_VALUE_1	Added column to table. Defined as VARCHAR2(30).
SITUATION_SUMMARY	COMBO_VALUE_2	Added column to table. Defined as VARCHAR2(30).

Table Name	Column Name/Definition	Description of Change
SITUATION_SUMMARY	COMBO_VALUE_3	Added column to table. Defined as VARCHAR2(30).
SITUATION_SUMMARY	COMBO_VALUE_4	Added column to table. Defined as VARCHAR2(30).
SITUATION_SUMMARY	COMBO_VALUE_5	Added column to table. Defined as VARCHAR2(30).
SITUATION_SUMMARY	COMBO_VALUE_6	Added column to table. Defined as VARCHAR2(30).
SITUATION_SUMMARY	COMMUNITY_CONDITION	Dropped column.
SITUATION_SUMMARY	HAZARD_ID	Added column to table. Defined as NUMBER(9).
SITUATION_SUMMARY	HAZARD_TYPE	Dropped column.
SITUATION_SUMMARY	ORGANIZATIONAL_CONDITION	Dropped column.
SITUATION_SUMMARY	OTHER_CONDITION	Dropped column.
SITUATION_SUMMARY	POP_COND_NAME	Dropped column.
SITUATION_SUMMARY	PROT_ACT_INDEX	Added column to table. Defined as NUMBER(2).
SITUATION_SUMMARY	ROAD_CONDITION	Dropped column.
SITUATION_SUMMARY	SITUATION_COMMENT	Dropped column.
SITUATION_SUMMARY	SITUATION_SEASON	Dropped column.
SITUATION_SUMMARY	SPECIAL_WEATHER	Dropped column.
SITUATION_SUMMARY	SS_NAME	Added column to table. Defined as VARCHAR2(127).
SITUATION_SUMMARY	TEXT_VALUE_1	Added column to table. Defined as VARCHAR2(256).
SITUATION_SUMMARY	TEXT_VALUE_2	Added column to table. Defined as VARCHAR2(256).
SITUATION_SUMMARY	TEXT_VALUE_3	Added column to table. Defined as VARCHAR2(256).
SITUATION_SUMMARY	TEXT_VALUE_4	Added column to table. Defined as VARCHAR2(256).
SITUATION_SUMMARY	TEXT_VALUE_5	Added column to table. Defined as VARCHAR2(256).
SITUATION_SUMMARY	TEXT_VALUE_6	Added column to table. Defined as VARCHAR2(256).
SITUATION_SUMMARY	XMIT_INIT_DATE	Added column to table. Defined as DATE.
TRACKED_PERSON	CEL_PHONE	Added column to table. Defined as VARCHAR2(30).
TRACKED_PERSON	EMAIL_ADDRESS2	Added column to table. Defined as VARCHAR2(80).

Table Name	Column Name/Definition	Description of Change
TRACKED_PERSON	TK_BEEPER_PHONE	Lengthen to 30 characters.
TRACKED_PERSON	TK_COMMENT	Lengthen to 255 characters.
TRACKED_PERSON	TK_EMAIL_ADDRESS	Lengthen to 80 characters.
TRACKED_PERSON	TK_FAX_PHONE	Lengthen to 30 characters.
TRACKED_PERSON	TK_HOME_PHONE	Lengthen to 30 characters.
TRACKED_PERSON	WEB_ADDRESS	Added column to table. Defined as VARCHAR2(255).
UDS_COLUMN	AGGR_ITEM_ATTRIBUTES	Added column to table. Defined as VARCHAR2(2000).
UDS_COLUMN	AGGR_ITEM_NAME	Added column to table. Defined as VARCHAR2(30).
UDS_COLUMN	AGGR_PARENT_NAME	Added column to table. Defined as VARCHAR2(30).
UDS_COLUMN	EXTRA_ATTRIBUTES	Added column to table. Defined as VARCHAR2(2000).
UDS_COLUMN	FORM_FIELD_ATTRIBUTE	Added column to table. Defined as VARCHAR2(2000).
UDS_COLUMN	GRID_COLUMN_ATTRIBUTES	Added column to table. Defined as VARCHAR2(2000).
UDS_COLUMN	HAZARD_ID	Added column to table. Defined as NUMBER(9). Part of the PRIMARY_KEY.
UDS_COLUMN	MOD_COUNT	Added column to table. Defined as NUMBER(8).
UDS_COLUMN	MOD_DATE	Added column to table. Defined as DATE.
UDS_COLUMN	MOD_USERCODE	Added column to table. Defined as VARCHAR2(30).
UDS_COLUMN	MOD_USERNAME	Added column to table. Defined as VARCHAR2(60).
UDS_COLUMN	SQL_DATA_TYPE	Added column to table. Defined as VARCHAR2(30).
UDS_ROW	EXTRA_ATTRIBUTES	Added column to table. Defined as VARCHAR2(2000).
UDS_ROW	HAZARD_ID	Added column to table. Defined as NUMBER(9). Part of the PRIMARY_KEY.
UDS_ROW	MOD_COUNT	Added column to table. Defined as NUMBER(8).
UDS_ROW	MOD_DATE	Added column to table. Defined as DATE.
UDS_ROW	MOD_USERCODE	Added column to table. Defined as VARCHAR2(30).

Table Name	Column Name/Definition	Description of Change
UDS_ROW	MOD_USERNAME	Added column to table. Defined as VARCHAR2(60).
UDS_ROW	UDS_DATE11	Added column to table. Defined as DATE.
UDS_ROW	UDS_DATE12	Added column to table. Defined as DATE.
UDS_ROW	UDS_DATE13	Added column to table. Defined as DATE.
UDS_ROW	UDS_DATE14	Added column to table. Defined as DATE.
UDS_ROW	UDS_DATE15	Added column to table. Defined as DATE.
UDS_ROW	UDS_DATE16	Added column to table. Defined as DATE.
UDS_ROW	UDS_DATE17	Added column to table. Defined as DATE.
UDS_ROW	UDS_DATE18	Added column to table. Defined as DATE.
UDS_ROW	UDS_DATE19	Added column to table. Defined as DATE.
UDS_ROW	UDS_DATE20	Added column to table. Defined as DATE.
UDS_ROW	UDS_NUMBER11	Added column to table. Defined as NUMBER.
UDS_ROW	UDS_NUMBER12	Added column to table. Defined as NUMBER.
UDS_ROW	UDS_NUMBER13	Added column to table. Defined as NUMBER.
UDS_ROW	UDS_NUMBER14	Added column to table. Defined as NUMBER.
UDS_ROW	UDS_NUMBER15	Added column to table. Defined as NUMBER.
UDS_ROW	UDS_NUMBER16	Added column to table. Defined as NUMBER.
UDS_ROW	UDS_NUMBER17	Added column to table. Defined as NUMBER.
UDS_ROW	UDS_NUMBER18	Added column to table. Defined as NUMBER.
UDS_ROW	UDS_NUMBER19	Added column to table. Defined as NUMBER.
UDS_ROW	UDS_NUMBER20	Added column to table. Defined as NUMBER.

Table Name	Column Name/Definition	Description of Change
UDS_ROW	UDS_NUMBER21	Added column to table. Defined as NUMBER.
UDS_ROW	UDS_NUMBER22	Added column to table. Defined as NUMBER.
UDS_ROW	UDS_NUMBER23	Added column to table. Defined as NUMBER.
UDS_ROW	UDS_NUMBER24	Added column to table. Defined as NUMBER.
UDS_ROW	UDS_NUMBER25	Added column to table. Defined as NUMBER.
UDS_ROW	UDS_NUMBER26	Added column to table. Defined as NUMBER.
UDS_ROW	UDS_NUMBER27	Added column to table. Defined as NUMBER.
UDS_ROW	UDS_NUMBER28	Added column to table. Defined as NUMBER.
UDS_ROW	UDS_NUMBER29	Added column to table. Defined as NUMBER.
UDS_ROW	UDS_NUMBER30	Added column to table. Defined as NUMBER.
UDS_ROW	UDS_VALUE11	Added column to table. Defined as VARCHAR2(2000).
UDS_ROW	UDS_VALUE12	Added column to table. Defined as VARCHAR2(2000).
UDS_ROW	UDS_VALUE13	Added column to table. Defined as VARCHAR2(2000).
UDS_ROW	UDS_VALUE14	Added column to table. Defined as VARCHAR2(2000).
UDS_ROW	UDS_VALUE15	Added column to table. Defined as VARCHAR2(2000).
UDS_ROW	UDS_VALUE16	Added column to table. Defined as VARCHAR2(2000).
UDS_ROW	UDS_VALUE17	Added column to table. Defined as VARCHAR2(2000).
UDS_ROW	UDS_VALUE18	Added column to table. Defined as VARCHAR2(2000).
UDS_ROW	UDS_VALUE19	Added column to table. Defined as VARCHAR2(2000).
UDS_ROW	UDS_VALUE20	Added column to table. Defined as VARCHAR2(2000).
UDS_ROW	UDS_VALUE21	Added column to table. Defined as VARCHAR2(2000).
UDS_ROW	UDS_VALUE22	Added column to table. Defined as VARCHAR2(2000).

Table Name	Column Name/Definition	Description of Change
UDS_ROW	UDS_VALUE23	Added column to table. Defined as VARCHAR2(2000).
UDS_ROW	UDS_VALUE24	Added column to table. Defined as VARCHAR2(2000).
UDS_ROW	UDS_VALUE25	Added column to table. Defined as VARCHAR2(2000).
UDS_ROW	UDS_VALUE26	Added column to table. Defined as VARCHAR2(2000).
UDS_ROW	UDS_VALUE27	Added column to table. Defined as VARCHAR2(2000).
UDS_ROW	UDS_VALUE28	Added column to table. Defined as VARCHAR2(2000).
UDS_ROW	UDS_VALUE29	Added column to table. Defined as VARCHAR2(2000).
UDS_ROW	UDS_VALUE30	Added column to table. Defined as VARCHAR2(2000).
UDS_ROW	UDS_VALUE31	Added column to table. Defined as VARCHAR2(2000).
UDS_ROW	UDS_VALUE32	Added column to table. Defined as VARCHAR2(2000).
UDS_ROW	UDS_VALUE33	Added column to table. Defined as VARCHAR2(2000).
UDS_ROW	UDS_VALUE34	Added column to table. Defined as VARCHAR2(2000).
UDS_ROW	UDS_VALUE35	Added column to table. Defined as VARCHAR2(2000).
UDS_ROW	UDS_VALUE36	Added column to table. Defined as VARCHAR2(2000).
UDS_ROW	UDS_VALUE37	Added column to table. Defined as VARCHAR2(2000).
UDS_ROW	UDS_VALUE38	Added column to table. Defined as VARCHAR2(2000).
UDS_ROW	UDS_VALUE39	Added column to table. Defined as VARCHAR2(2000).
UDS_ROW	UDS_VALUE40	Added column to table. Defined as VARCHAR2(2000).
UDS_ROW	UDS_YESNO10	Added column to table. Defined as VARCHAR2(1).
UDS_ROW	UDS_YESNO11	Added column to table. Defined as VARCHAR2(1).
UDS_ROW	UDS_YESNO12	Added column to table. Defined as VARCHAR2(1).

Table Name	Column Name/Definition	Description of Change
UDS_ROW	UDS_YESNO13	Added column to table. Defined as VARCHAR2(1).
UDS_ROW	UDS_YESNO14	Added column to table. Defined as VARCHAR2(1).
UDS_ROW	UDS_YESNO15	Added column to table. Defined as VARCHAR2(1).
UDS_ROW	UDS_YESNO16	Added column to table. Defined as VARCHAR2(1).
UDS_ROW	UDS_YESNO17	Added column to table. Defined as VARCHAR2(1).
UDS_ROW	UDS_YESNO18	Added column to table. Defined as VARCHAR2(1).
UDS_ROW	UDS_YESNO19	Added column to table. Defined as VARCHAR2(1).
UDS_ROW	UDS_YESNO20	Added column to table. Defined as VARCHAR2(1).
UDS_ROW	UDS_YESNO6	Added column to table. Defined as VARCHAR2(1).
UDS_ROW	UDS_YESNO7	Added column to table. Defined as VARCHAR2(1).
UDS_ROW	UDS_YESNO8	Added column to table. Defined as VARCHAR2(1).
UDS_ROW	UDS_YESNO9	Added column to table. Defined as VARCHAR2(1).
USER_DEFINED_STATUS	EXTRA_ATTRIBUTES	Added column to table. Defined as VARCHAR2(2000).
USER_DEFINED_STATUS	HAZARD_ID	Added column to table. Defined as NUMBER(9). Part of the PRIMARY_KEY.
USER_DEFINED_STATUS	MOD_COUNT	Added column to table. Defined as NUMBER(8).
USER_DEFINED_STATUS	MOD_DATE	Added column to table. Defined as DATE.
USER_DEFINED_STATUS	MOD_USERCODE	Added column to table. Defined as VARCHAR2(30).
USER_DEFINED_STATUS	MOD_USERNAME	Added column to table. Defined as VARCHAR2(60).
USER_DEFINED_STATUS	PRIMARY_DATA_TABLE	Added column to table. Defined as VARCHAR2(120).
USER_DEFINED_STATUS	RELATION_ATTRIBUTES1	Added column to table. Defined as VARCHAR2(2000).
USER_DEFINED_STATUS	RELATION_ATTRIBUTES2	Added column to table. Defined as VARCHAR2(2000).

Table Name	Column Name/Definition	Description of Change
USER_DEFINED_STATUS	RELATION_ATTRIBUTES3	Added column to table. Defined as VARCHAR2(2000).
USER_DEFINED_STATUS	RELATION_ATTRIBUTES4	Added column to table. Defined as VARCHAR2(2000).
USER_DEFINED_STATUS	RELATION_ATTRIBUTES5	Added column to table. Defined as VARCHAR2(2000).
USER_DEFINED_STATUS	RELATION_STRING1	Added column to table. Defined as VARCHAR2(2000).
USER_DEFINED_STATUS	RELATION_STRING2	Added column to table. Defined as VARCHAR2(2000).
USER_DEFINED_STATUS	RELATION_STRING3	Added column to table. Defined as VARCHAR2(2000).
USER_DEFINED_STATUS	RELATION_STRING4	Added column to table. Defined as VARCHAR2(2000).
USER_DEFINED_STATUS	RELATION_STRING5	Added column to table. Defined as VARCHAR2(2000).
USER_DEFINED_STATUS	SHARING_FLAGS	Added column to table. Defined as VARCHAR2(30).
USER_DEFINED_STATUS	TABLE1_ATTRIBUTES	Added column to table. Defined as VARCHAR2(2000).
USER_DEFINED_STATUS	TABLE2_ATTRIBUTES	Added column to table. Defined as VARCHAR2(2000).
USER_DEFINED_STATUS	TABLE3_ATTRIBUTES	Added column to table. Defined as VARCHAR2(2000).
USER_DEFINED_STATUS	TABLE4_ATTRIBUTES	Added column to table. Defined as VARCHAR2(2000).
USER_DEFINED_STATUS	TABLE5_ATTRIBUTES	Added column to table. Defined as VARCHAR2(2000).
USER_DEFINED_STATUS	VISIBILITY_ATTRIBUTES	Added column to table. Defined as VARCHAR2(2000).
USER_DEFINED_STATUS	VISIBILITY_FLAGS	Added column to table. Defined as VARCHAR2(30).
USER_MODE_PRIV	CP_NAME	Lengthened to VARCHAR2(60).
USER_MODEL_CASE		Modified the FOREIGN KEY to the LOCAL_CONFIG table.
USER_PREFERENCES		Created table.
WK_POSITION	AGENCY_CODE	Dropped column.
WK_POSITION	AGENCY_CODE	Dropped column.
WK_POSITION	WK_POSITION_ID	Added column to table. Defined as NUMBER(9) NOT NULL. Part of the PRIMARY KEY.

Table Name	Column Name/Definition	Description of Change
WK_POSITION	WK_POSITION_ID	Added column to table. Defined as NUMBER(9). Part of the PRIMARY KEY.
WORK_PLAN	LAST_CHANGE_DATE	Added column to table. Defined as DATE NOT NULL.
WORK_PLAN	LAST_CHANGE_PERSON	Added column to table. Defined as VARCHAR2(40) NOT NULL.
WORK_PLAN	WP_AUTHORIZED_BY	Dropped column.
WORK_PLAN_ACT	WORK_PLAN_INDEX	Added column to table. Defined as NUMBER(9) NOT NULL. Part of the PRIMARY KEY. Also part of the FOREIGN KEY to the WORK_PLAN table.
WORK_PLAN_ACT	WPA_AGENT_CODE	Added column to table. Defined as VARCHAR2(2).
WORK_PLAN_ACT	WPA_DESCRIPTION	Added column to table. Defined as VARCHAR2(254).
WORK_PLAN_ACT	WPA_INDEX	Dropped column.
WORK_PLAN_ACT	WPA_MUNITION_IN_ACT	Added column to table. Defined as NUMBER(7).
WORK_PLAN_ACT	WPA_MUNITION_TYPE	Added column to table. Defined as VARCHAR2(4).
WORK_PLAN_ACT	WPA_NOTE	Added column to table. Defined as VARCHAR2(254).
ZONE	POLYGONAL_LAYER_ID	Added column to table. Defined as NUMBER(9). Part of the PRIMARY KEY. Also a FOREIGN KEY for the POLYGONAL_LAYER table.
ZONE_CLUSTER_IN_GROUP	POLYGONAL_LAYER_ID	Added column to table. Defined as NUMBER(9). Also a FOREIGN KEY for the POLYGONAL_LAYER table.
ZONE_IN_GROUP	EOC_NAME	Added column to table. Defined as VARCHAR2(30).
ZONE_IN_GROUP	POLYGONAL_LAYER_ID	Added column to table. Defined as NUMBER(9) NOT NULL. Part of the PRIMARY KEY. Also part of a FOREIGN KEY for the ZONE table.
ZONE_RISK_GROUP	EDIT_FLAG	Added column to table. Defined as VARCHAR2(1).
ZONE_RISK_GROUP	EOC_NAME	Added column to table. Defined as VARCHAR2(30).

GIS Changes

The structural changes to the GIS in upgrading from FEMIS v1.4.5 to v1.4.6 involve changes to the FEMISGIS.INI file and dynamic themes.

FEMISGIS.INI File

Modification of the structure of the FEMISGIS.INI file:

1. Changed the name of the site code section from [SiteCode] to [SITE_CODE] for consistency with the other section names.
2. Added a [FEMIS_VERSION] section to identify the FEMIS version number and GIS size category (small, medium, or large) referenced by this file.
3. Added a [DEFAULT_HAZARD_THEME] section to identify the default polygonal theme that contains emergency “zones” for Risk Area and PAR/PAD.
4. Replaced the [THEME_PARAMETERS] section with two sections: [STATIC_THEMES] and [DYNAMIC_THEMES] to differentiate between the static themes that cannot be changed by the FEMIS application and the dynamic themes that are updated in the GIS as information in the relational database is changed.
5. Addition of the following data columns (theme parameters) to the theme definition lines in the [STATIC_THEMES] and [DYNAMIC_THEMES] sections:

Load Flag – indicates whether to load (include) this theme in the GIS (used to create "medium" and "small" INI versions). Previously the themes to be excluded were “commented out” by a single quote (apostrophe) as the first character in the line.

Display Order – indicates the relative order (top to bottom) in which to place the theme’s legend in the ArcView Table of Contents. A theme with a small display order number will be placed near the top of the Table of Contents and will be drawn on the map after all themes below it (with larger Display Order numbers) have been drawn.

Customize Flag – (Applies only to dynamic themes.) A yes value indicates that the theme will retain the (possibly customized) display parameters stored initially in the INI file. A value of no indicates that any changes made in the theme's display parameters from the FEMIS application and stored in the relational database will be used to dynamically update the theme's display characteristics when the theme is regenerated.

Back Color— Contains a color palette index (number) specifying the background color to be used in the theme's default display symbolization. Applies primarily to polygonal features, although some point symbols include a background color. (The existing Color column specifies the foreground color of the symbol.)

Outline Color— Specifies the outline color to be used in the theme's default display symbolization. Applies only to polygonal features.

6. Modification of the allowable values of the Default Legend column:

Simple indicates that a simple legend consisting of a single point, line, or polygon symbol is to be used for all features in the theme.

Classify indicates that a classification legend is to be used based on the values in the theme's attribute column as specified by the Classification Field, and the corresponding symbol entries in the object type lookup table (obj_type.lut) file for the theme type (object type) specified in the Object Lookup Category column.

None or N/A indicates that the theme is a raster image file or other type of theme for which the concept of a classification legend is not applicable.

Dynamic Themes

Dynamic themes for pre-defined polygon classes have been added. For this version, this includes Generic User Defined Polygons and Flood Polygons. These themes will be created and displayed in the GIS only when there are polygon features defined in the FEMIS interface and Oracle database for those themes.

The Siren theme has been transferred from a static to a dynamic theme. Sirens are now included in the pre-defined point classes.

The capability for users to add new classes for user defined point themes has been added. The FEMISGIS.INI file is automatically updated to add a new theme definition line in the Dynamic Themes section for each new user defined point theme.

Appendix C

Database Data Models

Appendix C – Database Data Models

The diagrams for the main data model illustrate what information is present and how the data objects are interrelated. The data model can be assembled so you can view the entire schema. For the data model, pages C-2 through C-21 should be assembled like the following.

C-2	C-3	C-4	C-5
C-6	C-7	C-8	C-9
C-10	C-11	C-12	C-13
C-14	C-15	C-16	C-17
C-18	C-19	C-20	C-21

The second data model included in this appendix is the data model for LOCATION_TYPE tables (page C-22). These relationships were removed from the large data model to reduce complexity.

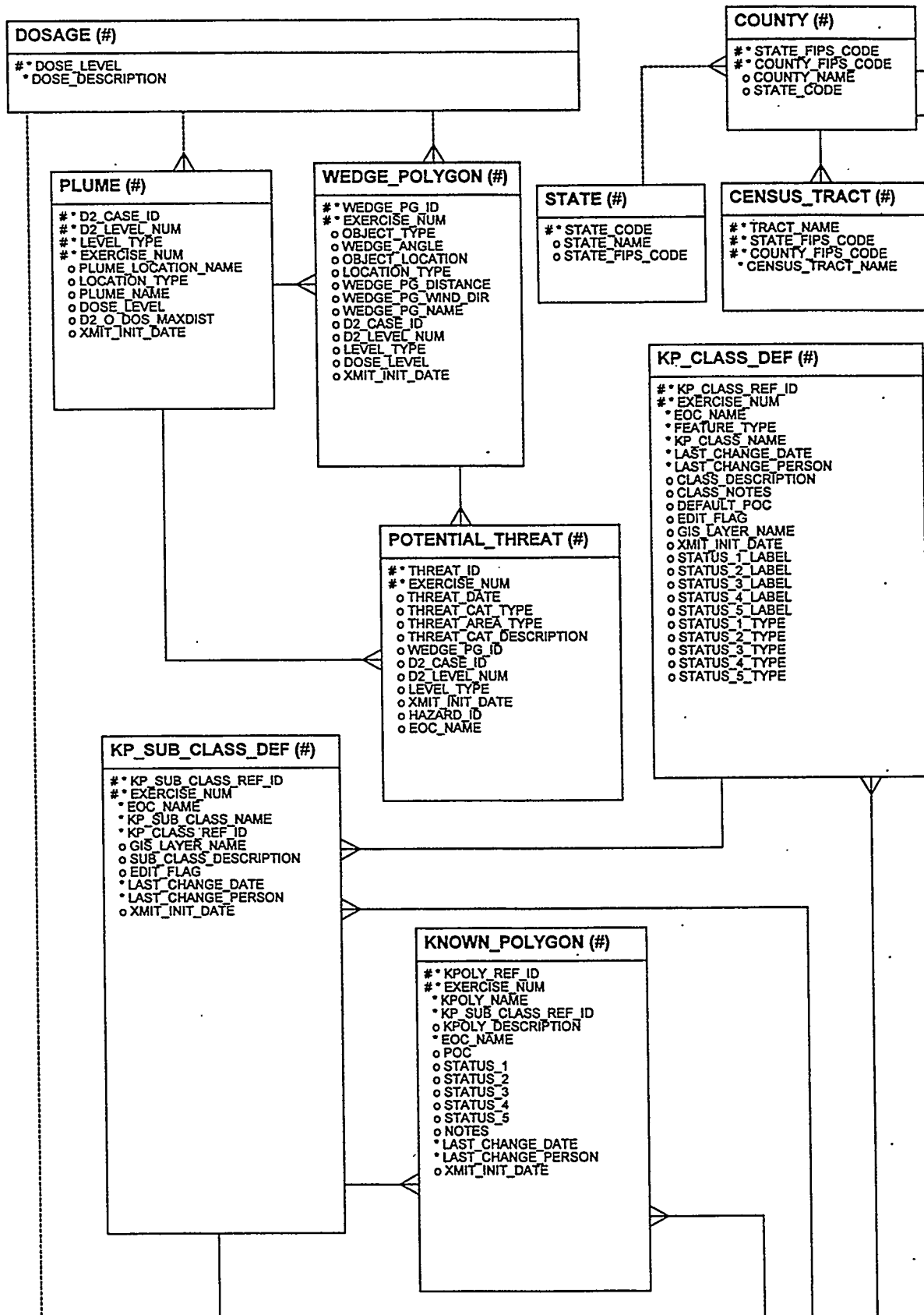

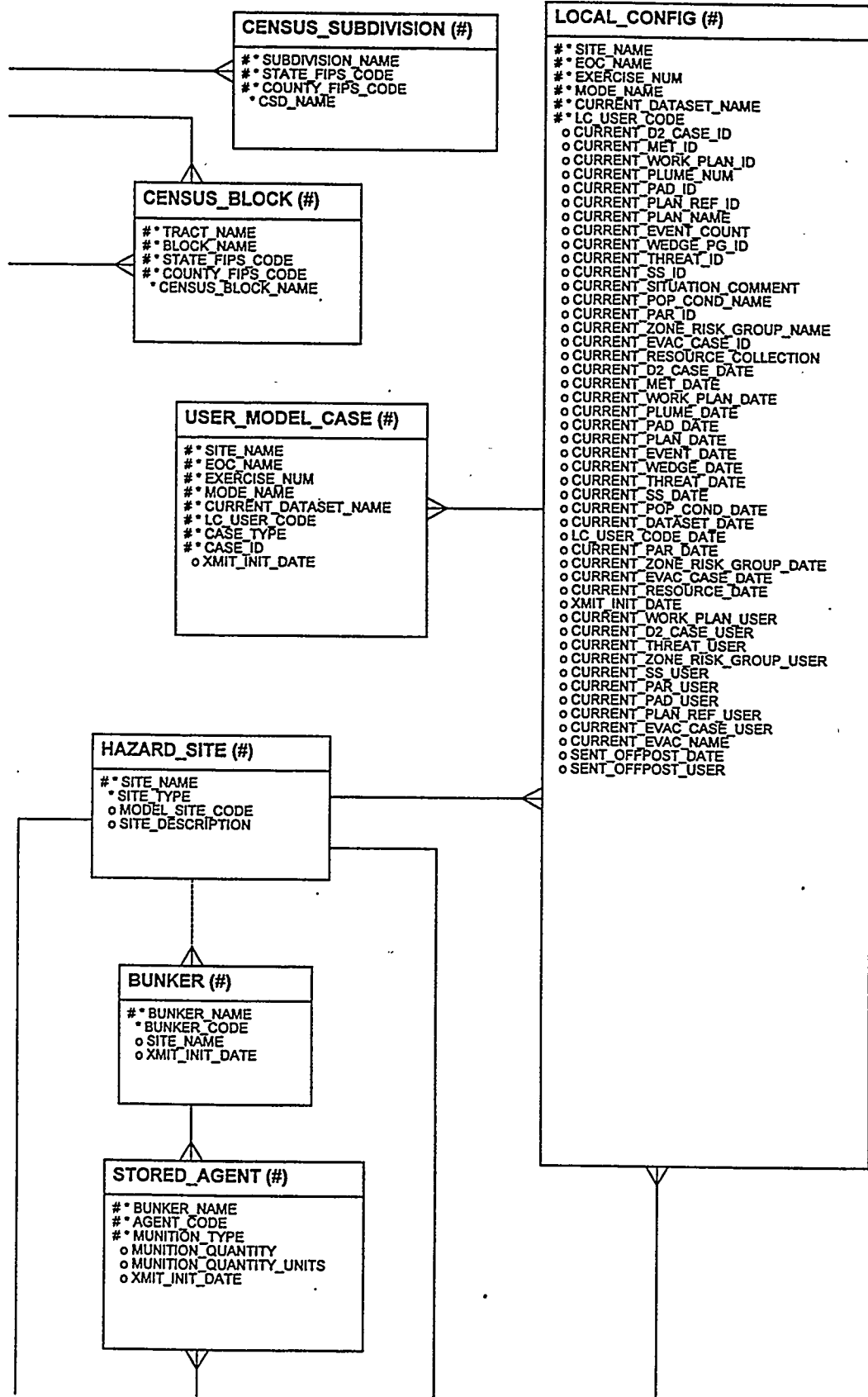

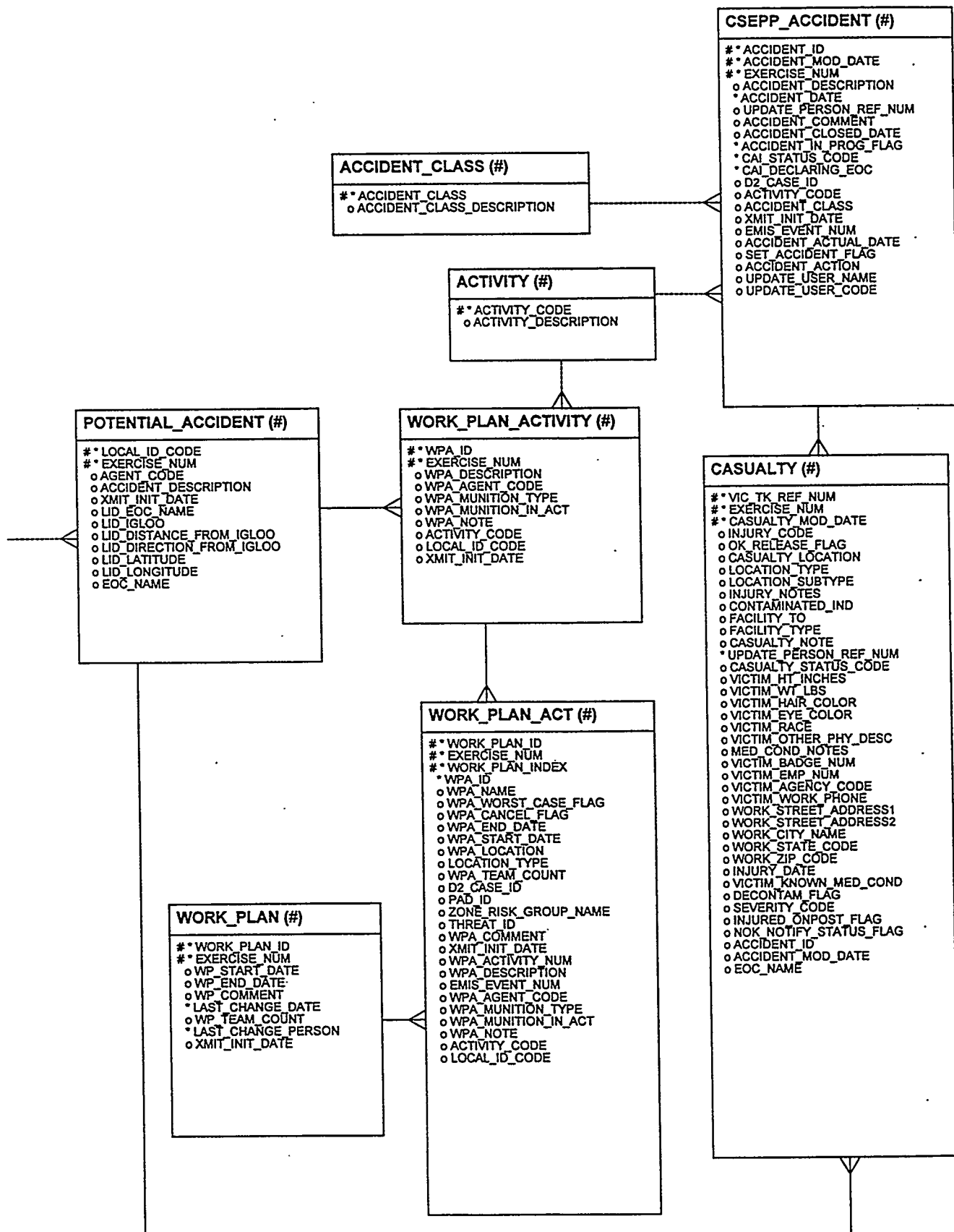

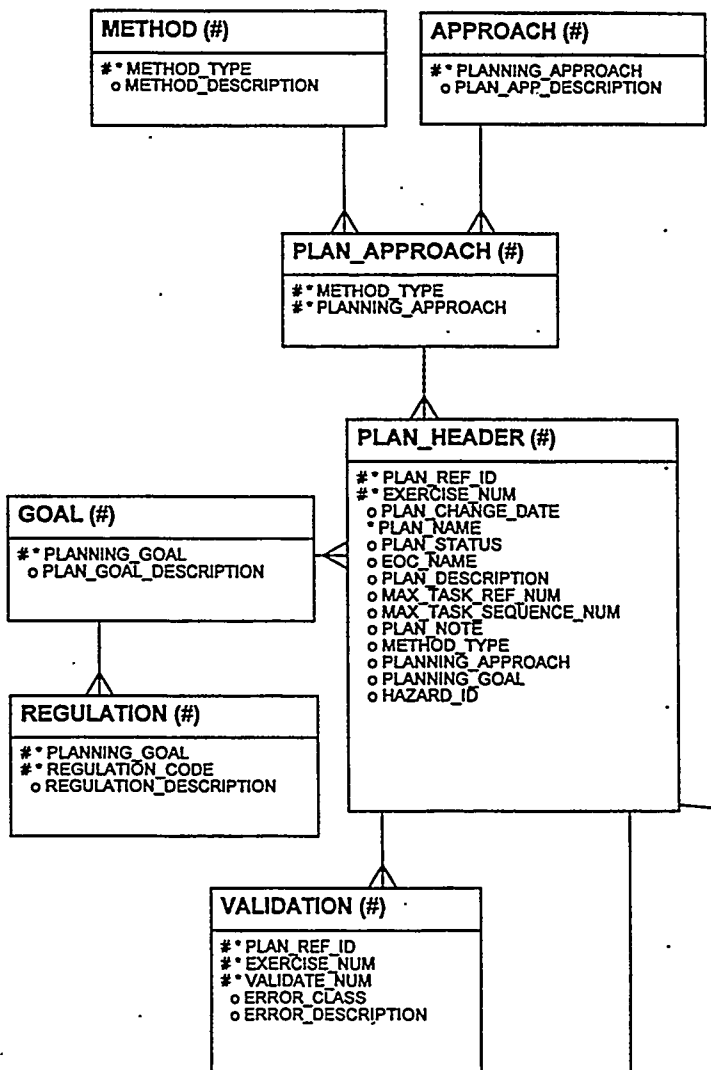

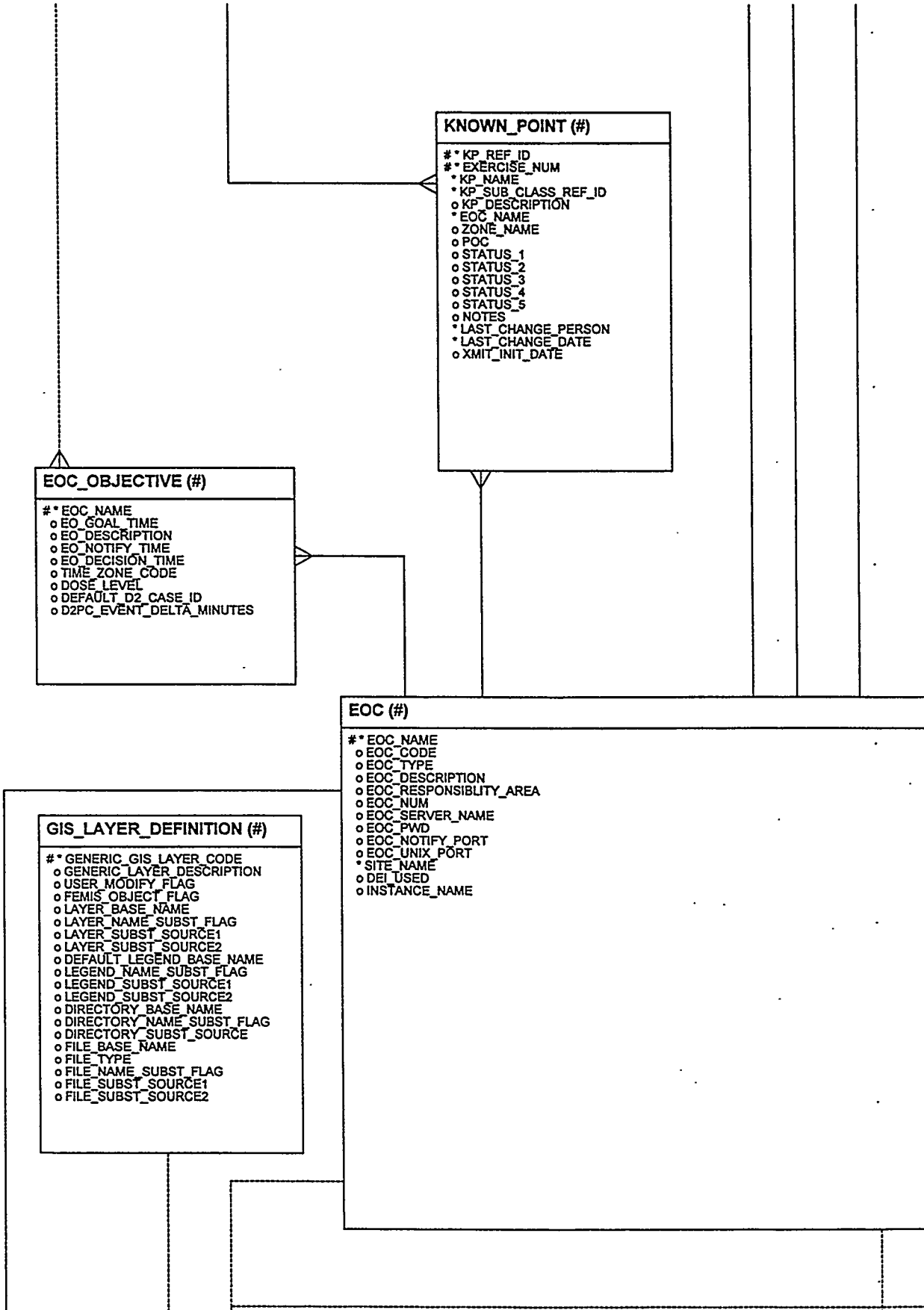

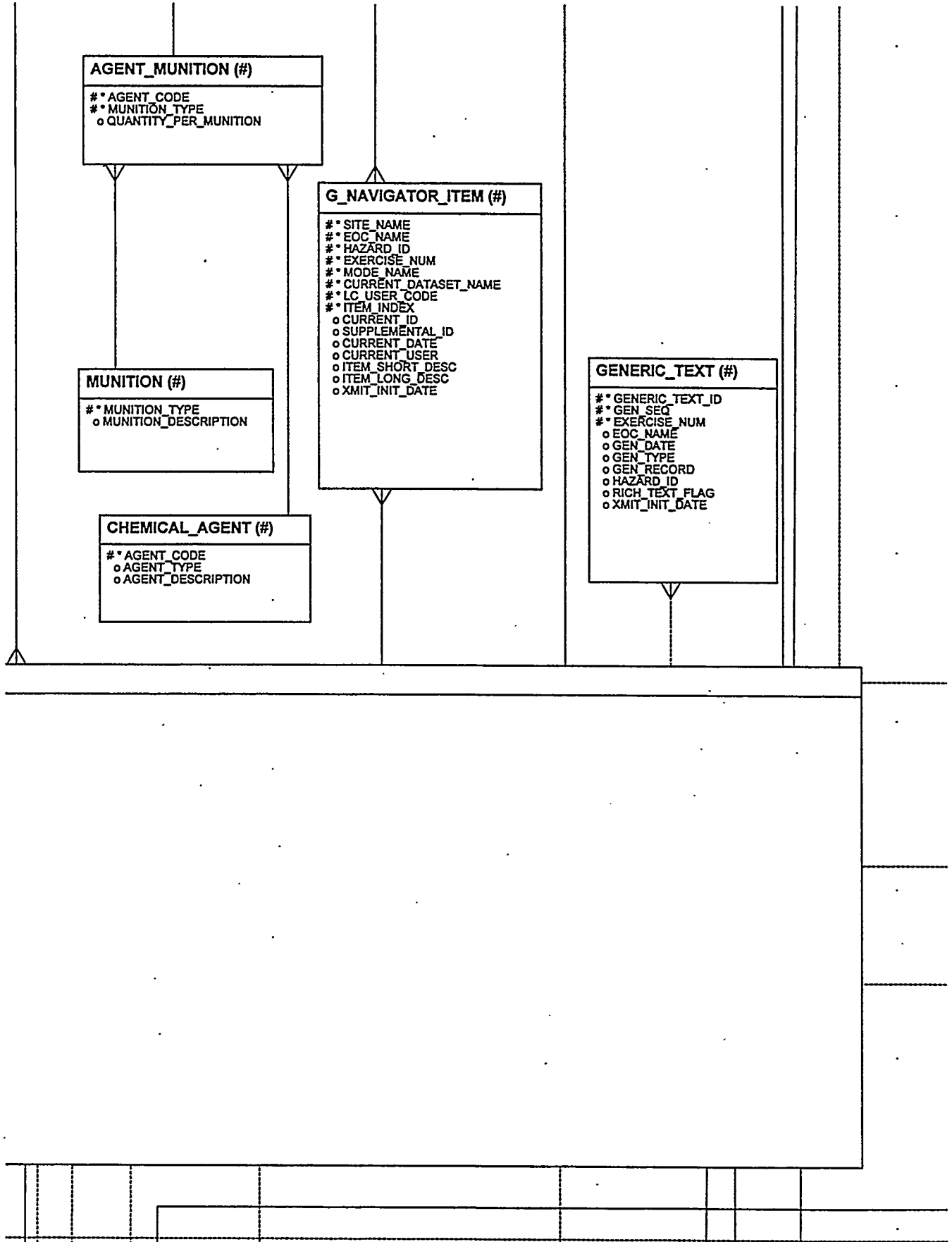

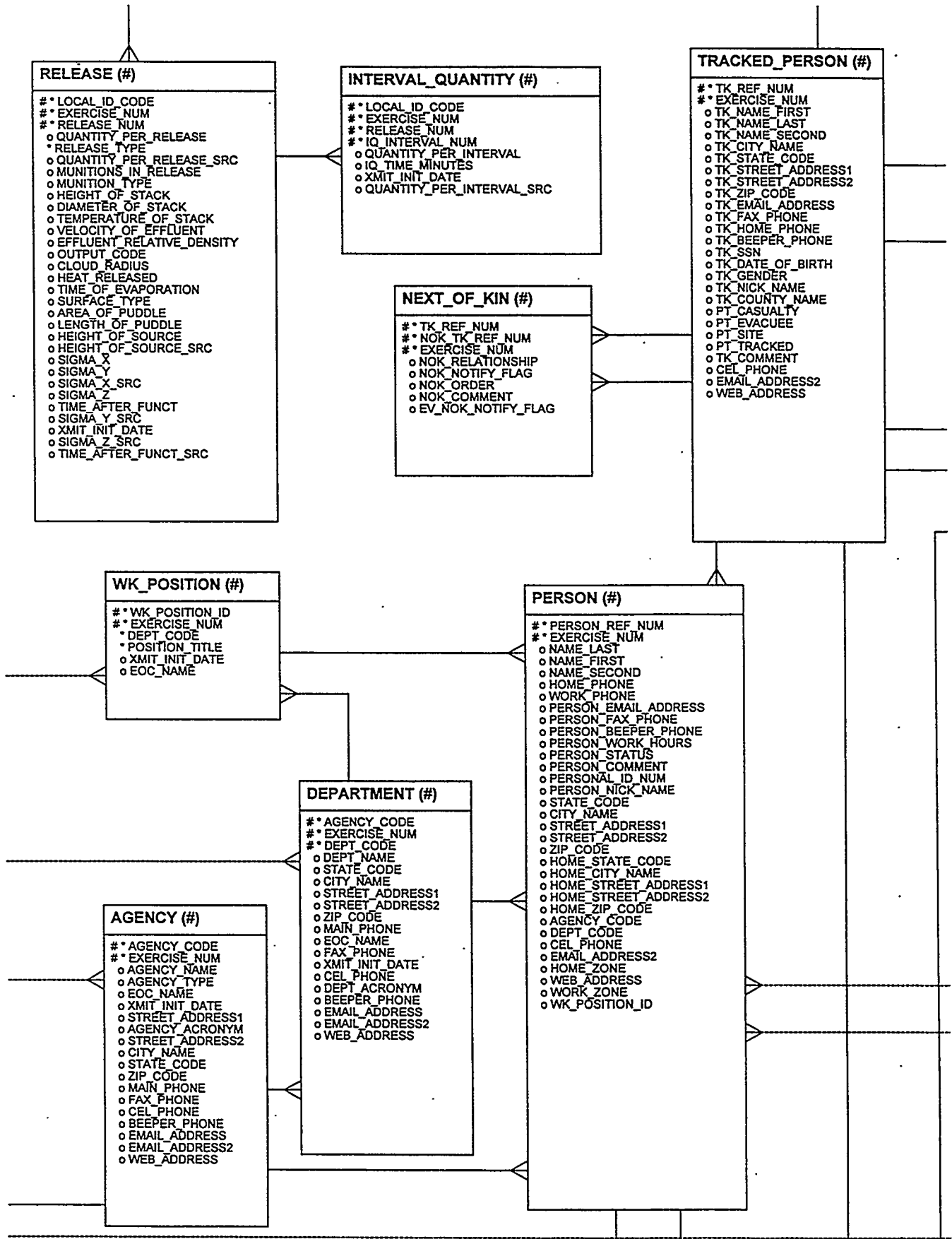

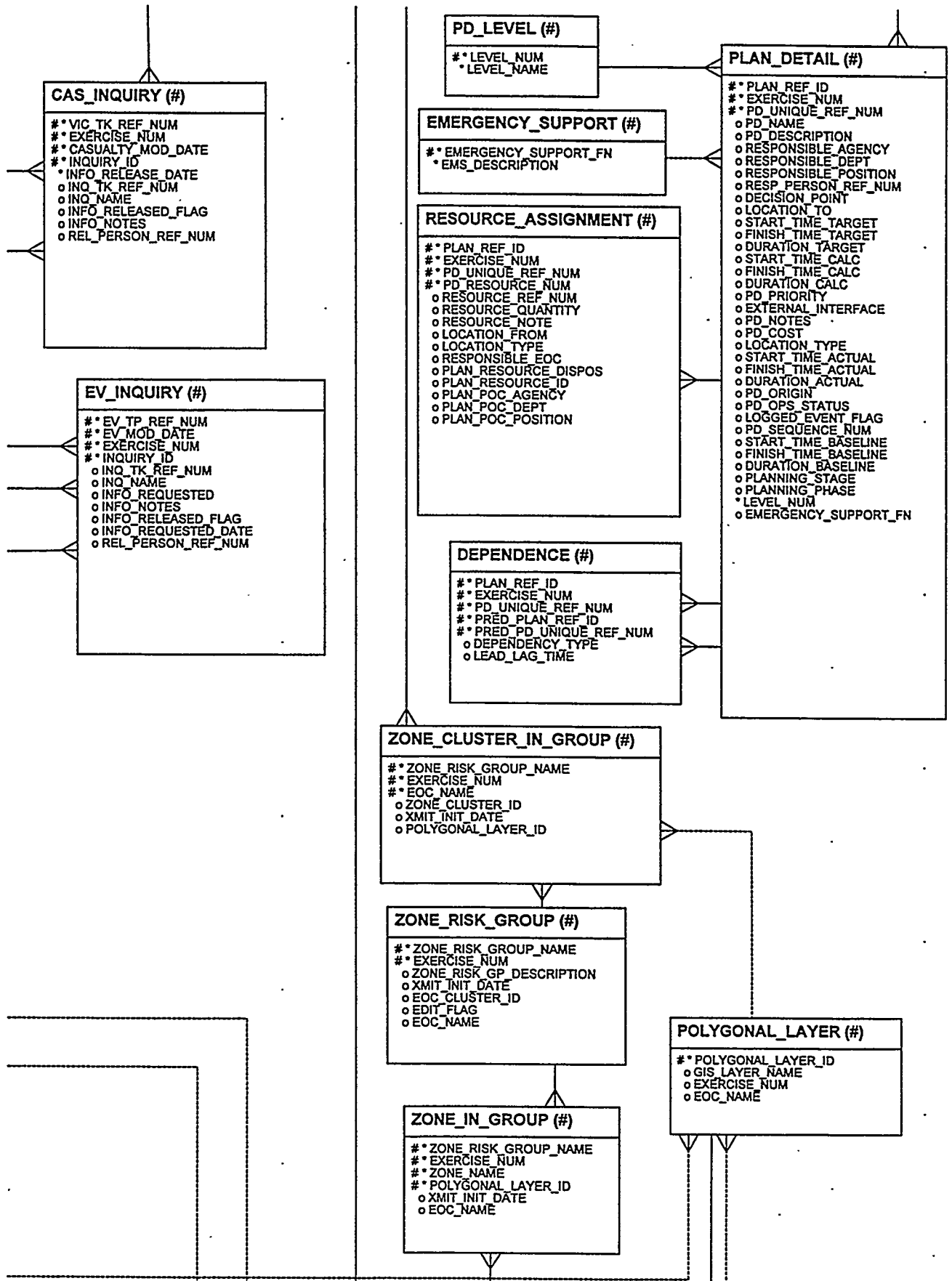

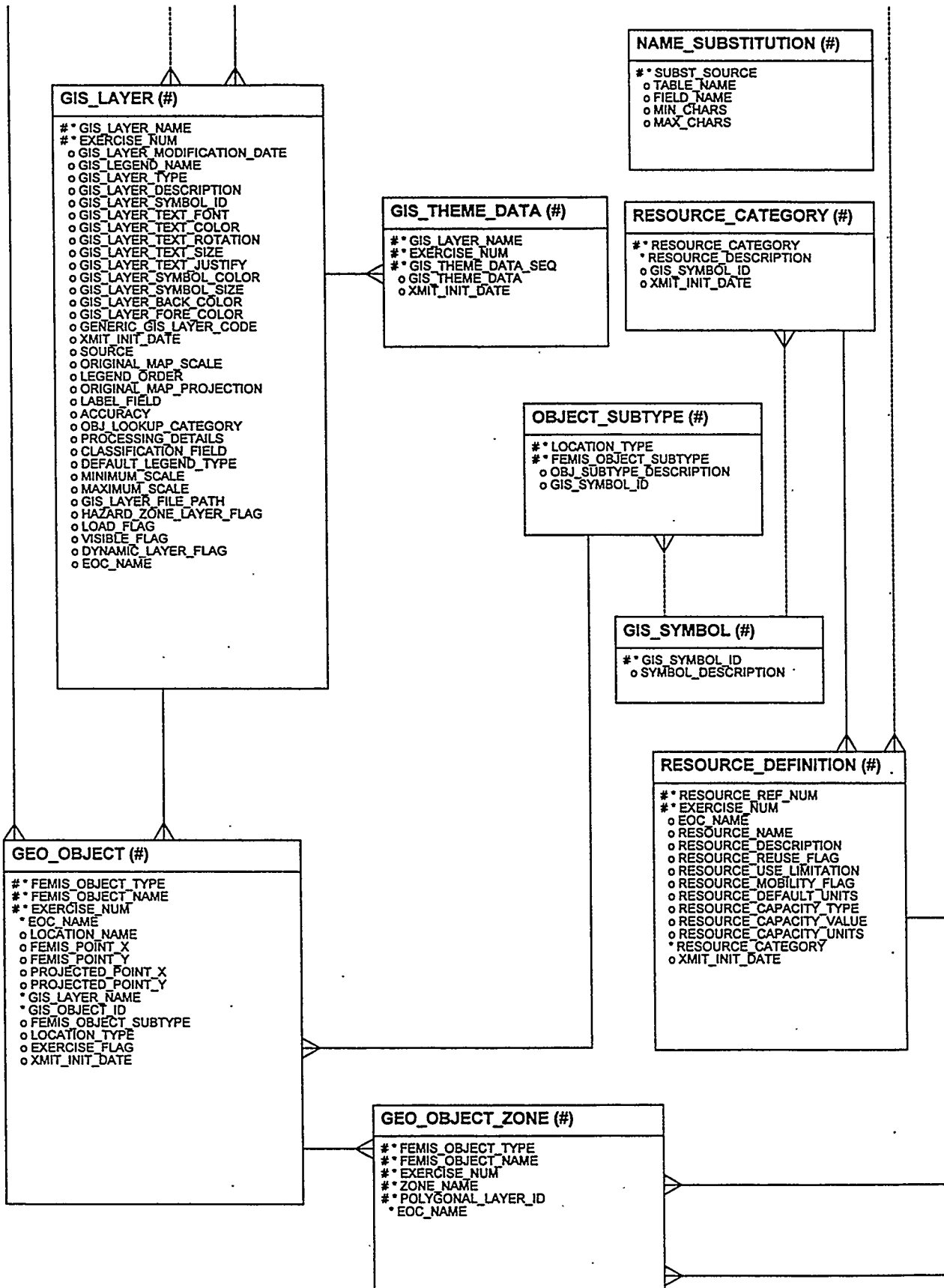

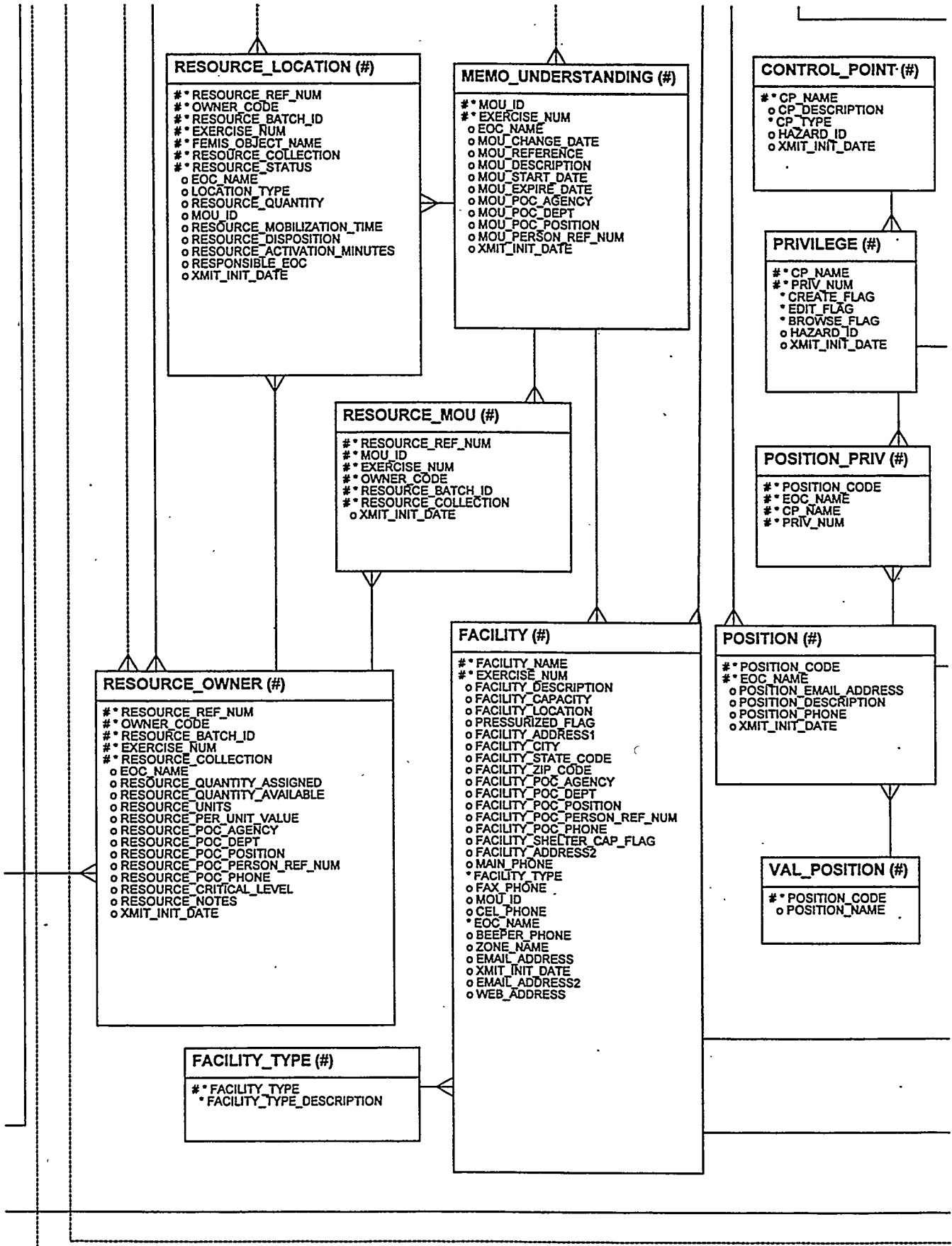

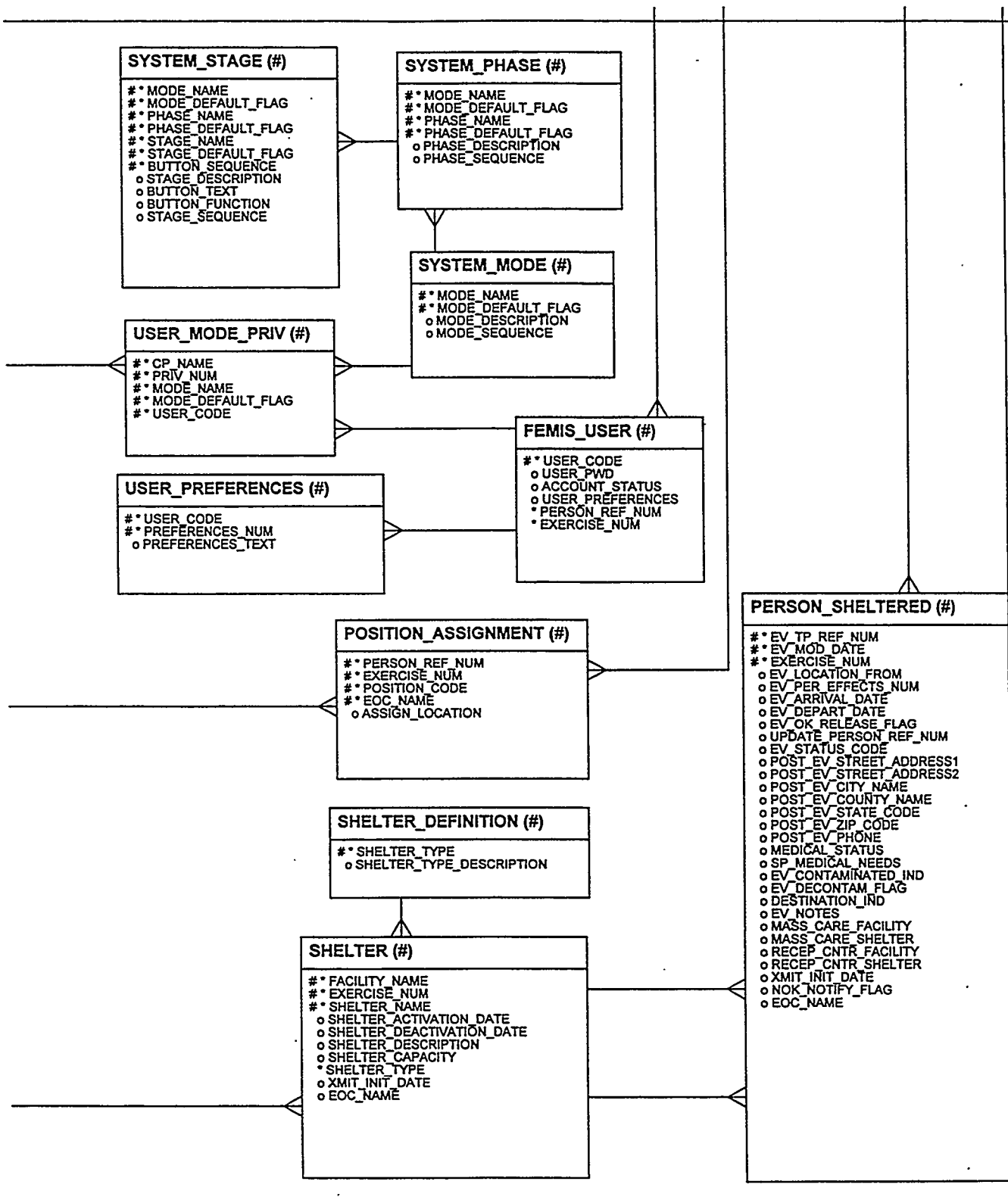

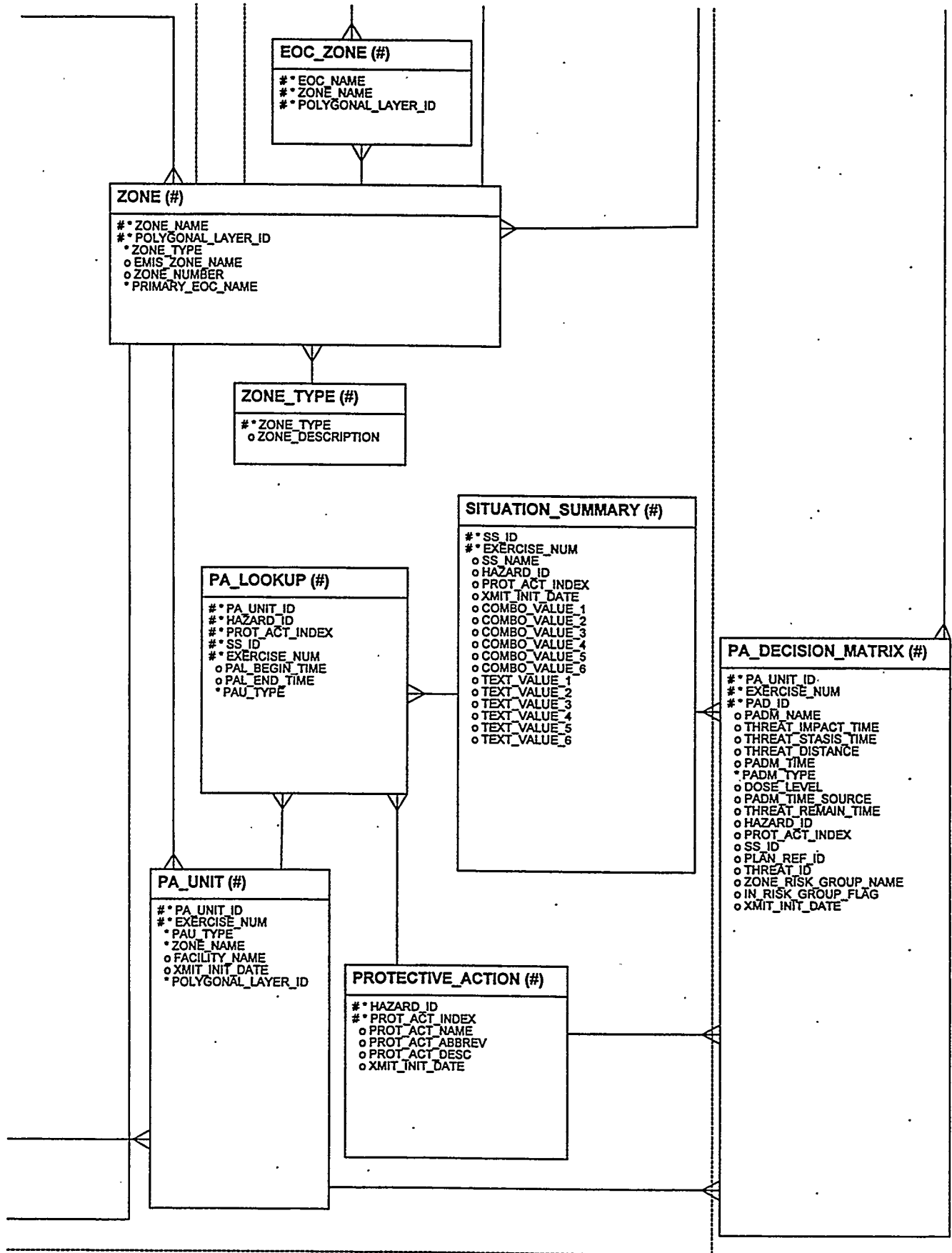

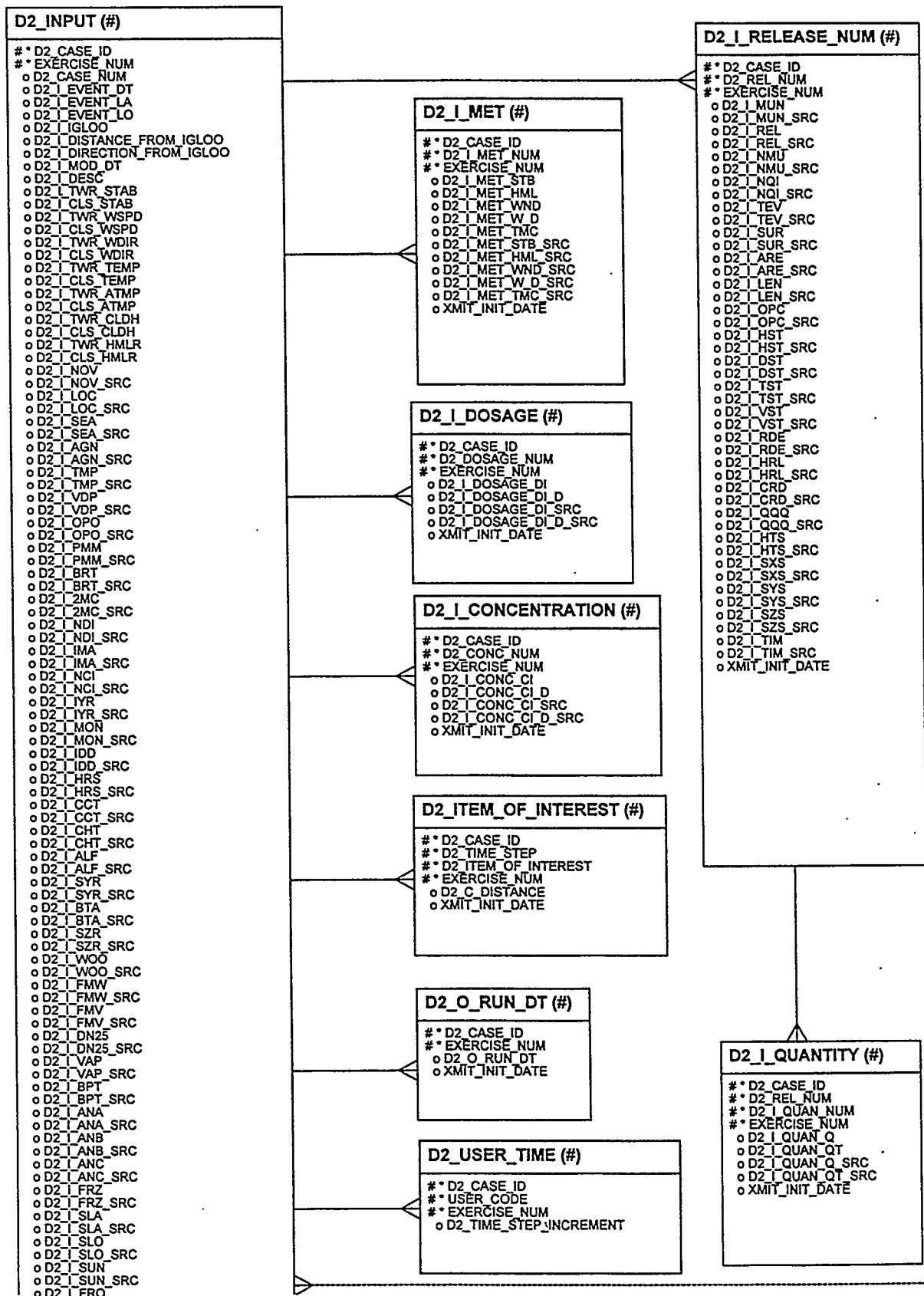

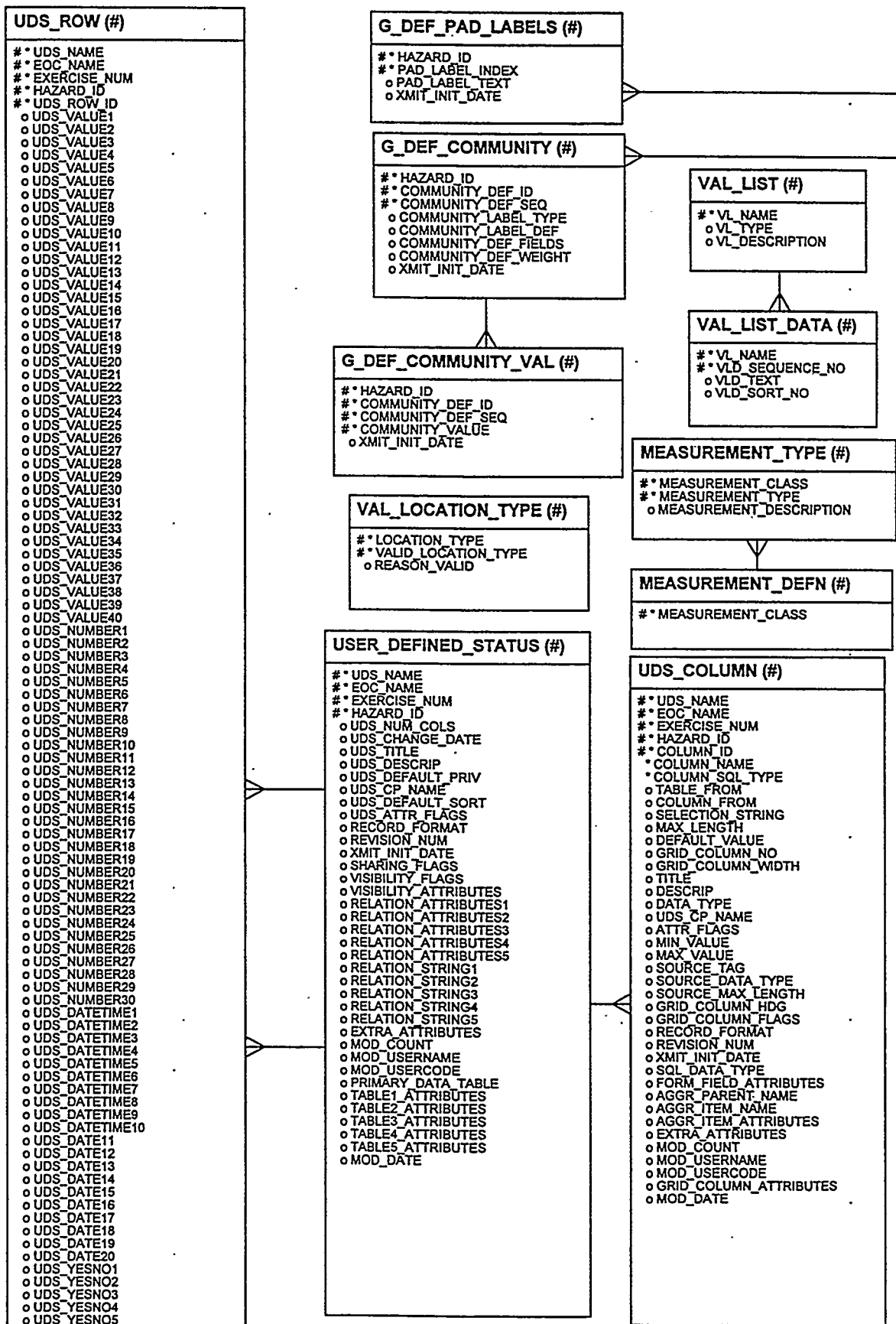

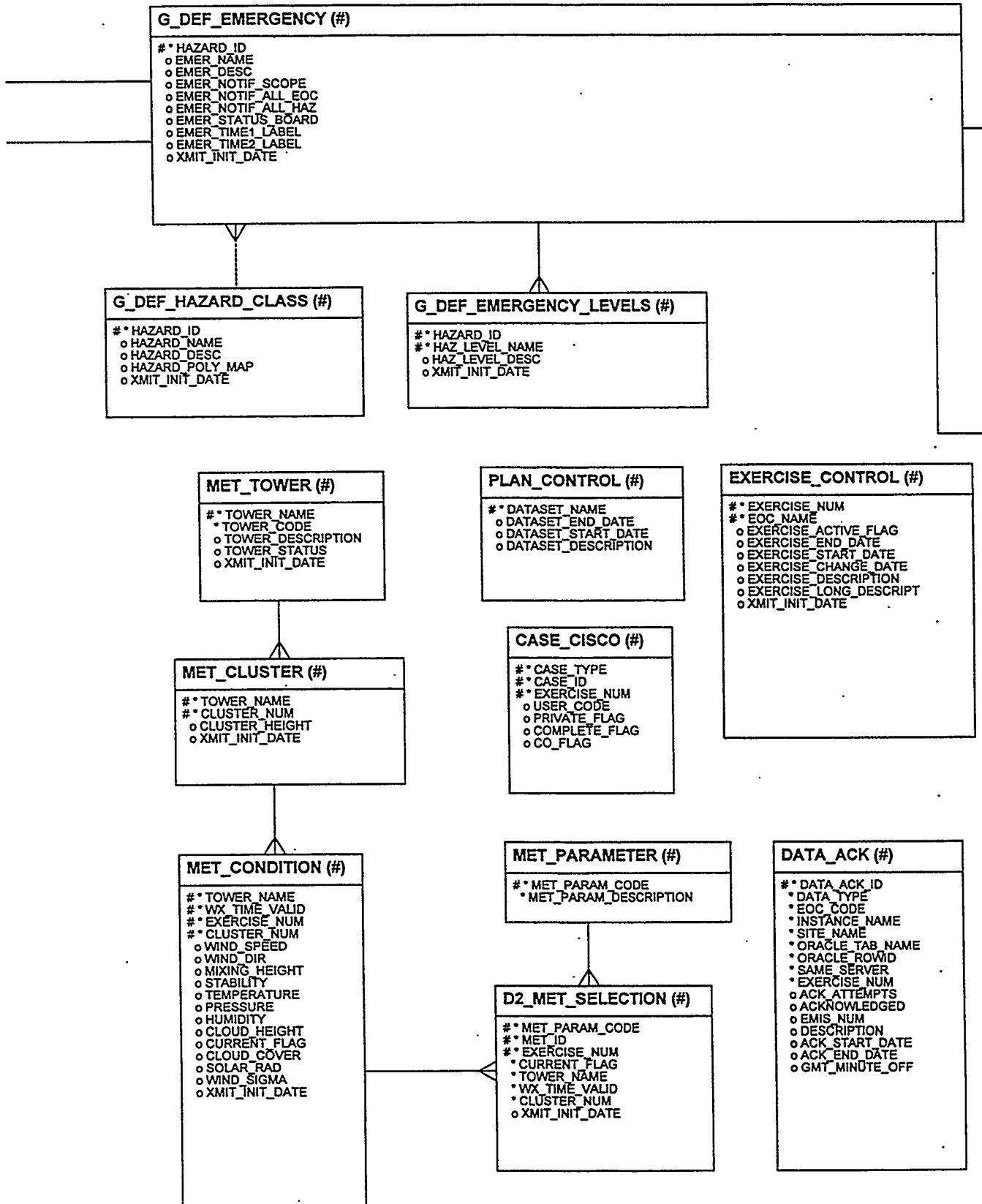

G_EMERGENCY (#)	
#*	EOC NAME
#*	HAZARD ID
#*	EXERCISE NUM
#*	EMERGENCY ID
#*	EMER_MOD_DATE
o	EMER_NAME
o	EMER_DESC
o	EMER_PERSON_DECLARED
o	EMER_USER_CODE
o	EMER_DATE_CLOSED
o	EMER_IN_PROG_FLAG
o	EMER_CURRENT_RECORD
o	EMER_NOTIF_ALL_EOC
o	EMER_NOTIF_ALL_HAZ
o	HAZ_LEVEL_NAME
o	EMER_TIME1
o	EMER_TIME2
o	XMIT_INIT_DATE

G_DEF_NAV_FUNCTION (#)	
#*	FUNCTION ID
o	VALID_NAV_INDEX
o	FUNCTION_NAME
o	FUNCTION_DESC
o	FUNCTION_TYPE
o	XMIT_INIT_DATE

JOURNAL (#)	
#*	JOURNAL_REC_ID
#*	EOC NAME
#*	EXERCISE NUM
o	JOURNAL_ENTERED_DATE
o	JOURNAL_CATEGORY
o	JOURNAL_PERSON_REF_NUM
o	JOURNAL_ACTUAL_TIME
o	JOURNAL_SUBJECT
o	JOURNAL_INFORMATION
o	JOURNAL_MANUAL_ENTRY_FLAG
o	JOURNAL_ATTR_FLAGS
o	JOURNAL_USER_NAME
o	JOURNAL_USER_CODE
o	HAZARD ID
o	XMIT_INIT_DATE

G_DEF_NAV_FUNCTION_IO (#)	
#*	FUNCTION ID
#*	DATA FORMAT NAME
o	DATA_FORMAT_DESC
o	DATA_FORMAT_TYPE
o	XMIT_INIT_DATE

G_DEF_NAV_BUTTON (#)	
#*	HAZARD ID
#*	BUTTON_INDEX
o	BUTTON_DEFINED
o	LABEL_NAME
o	AVAIL_IN_OPS
o	AVAIL_IN_PLAN
o	AVAIL_ON_NAV
o	AVAIL_ON_MENU
o	EXE_NAME
o	FUNCTION_ID
o	INPUT_FORMAT
o	OUTPUT_FORMAT
o	MAP_AVAILABLE
o	MAP_FUNCTION
o	AUTOCALC_AVAILABLE
o	AUTOCALC_FUNCTION
o	XMIT_INIT_DATE

PROGRAM_LOCK (#)	
#*	LOCK NAME
#*	LOCK ITEM
#*	EXERCISE NUM
o	LOCK_TYPE
o	LOCK_USER
o	LOCK_DATE
o	LOCK_PC
o	LOCK_PROGRAM

REPLICATION_TEST (#)	
#*	POINT_NAME
#*	EXERCISE NUM
o	POINT_DESCRIPTION

ROUTE (#)	
#*	EXERCISE NUM
#*	ROUTE_NAME
o	ROUTE_DESCRIPTION
o	ROUTE_FLAG
o	ROUTE_TO_LOCATION
o	ROUTE_FROM_LOCATION

ROAD_QUALIFICATION (#)	
#*	EXERCISE NUM
#*	ROAD CLASS
o	RQ_INCLUDE_FLAG
o	RQ_FREE_FLOW_SPEED
o	RQ_LANE_COUNT
o	RQ_DIVIDED_FLAG
o	RQ_DEFAULT_FLAG

EV_I_175_TA_PARMS (#)	
#*	EVAC_CASE ID
#*	EV TIME PERIOD
#*	EXERCISE NUM
o	EV_I_175_EXP_VAL
o	EV_I_175_MAX_INNER_ITER
o	EV_I_175_COEFF_A
o	EV_I_175_COEFF_B
o	EV_I_175_KALMAN_FILTER
o	EV_I_175_MAX_OUTER_ITER
o	EV_I_175_LS_ACC
o	EV_I_175_IMP_CODE
o	EV_I_175_OPT_CODE
o	EV_I_175_TA_CODE
o	EV_I_175_PCT_DISCHARGE
o	EV_I_175_PCT_IMPED

ROUTE_SEGMENT (#)	
#*	EXERCISE NUM
#*	ROUTE_NAME
#*	ROUTE_SEG_NUM
o	ROUTE_SEG_LOCATION
o	RS_TO_LOCATION
o	RS_FROM_LOCATION
o	RS_ID

EV_I_034_FREEWAY_SUB_PARM (#)	
#*	EVAC_CASE ID
#*	EXERCISE NUM
o	EV_I_034_REL_T_COEF
o	EV_I_034_ANT_COEF
o	EV_I_034_MAX_DUR_TS
o	EV_I_034_1ST_SDRG_R1
o	EV_I_034_1ST_SDRG_R2
o	EV_I_034_1ST_SDRG_R3
o	EV_I_034_2ND_SDRG_R1
o	EV_I_034_2ND_SDRG_R2
o	EV_I_034_2ND_SDRG_R3
o	EV_I_034_3RD_SDRG_R1
o	EV_I_034_3RD_SDRG_R2
o	EV_I_034_3RD_SDRG_R3
o	EV_I_034_4TH_SDRG_R1
o	EV_I_034_4TH_SDRG_R2
o	EV_I_034_4TH_SDRG_R3
o	EV_I_034_5TH_SDRG_R3
o	EV_I_034_JAM_DEN

EV_I_035_036_SIGNAL (#)	
#*	EVAC_CASE ID
#*	EV NODE_NUM
#*	EXERCISE NUM
o	EV_I_035_REF_OFFSET
o	EV_I_035_NN_UP_1
o	EV_I_035_NN_UP_2
o	EV_I_035_NN_UP_3
o	EV_I_035_NN_UP_4
o	EV_I_035_NN_UP_5
o	EV_I_035_SIG_INT_1
o	EV_I_035_SIG_INT_2
o	EV_I_035_SIG_INT_3
o	EV_I_035_SIG_INT_4
o	EV_I_035_SIG_INT_5
o	EV_I_035_SIG_INT_6
o	EV_I_035_SIG_INT_7
o	EV_I_035_SIG_INT_8
o	EV_I_035_SIG_INT_9
o	EV_I_036_CONTROL_CODE

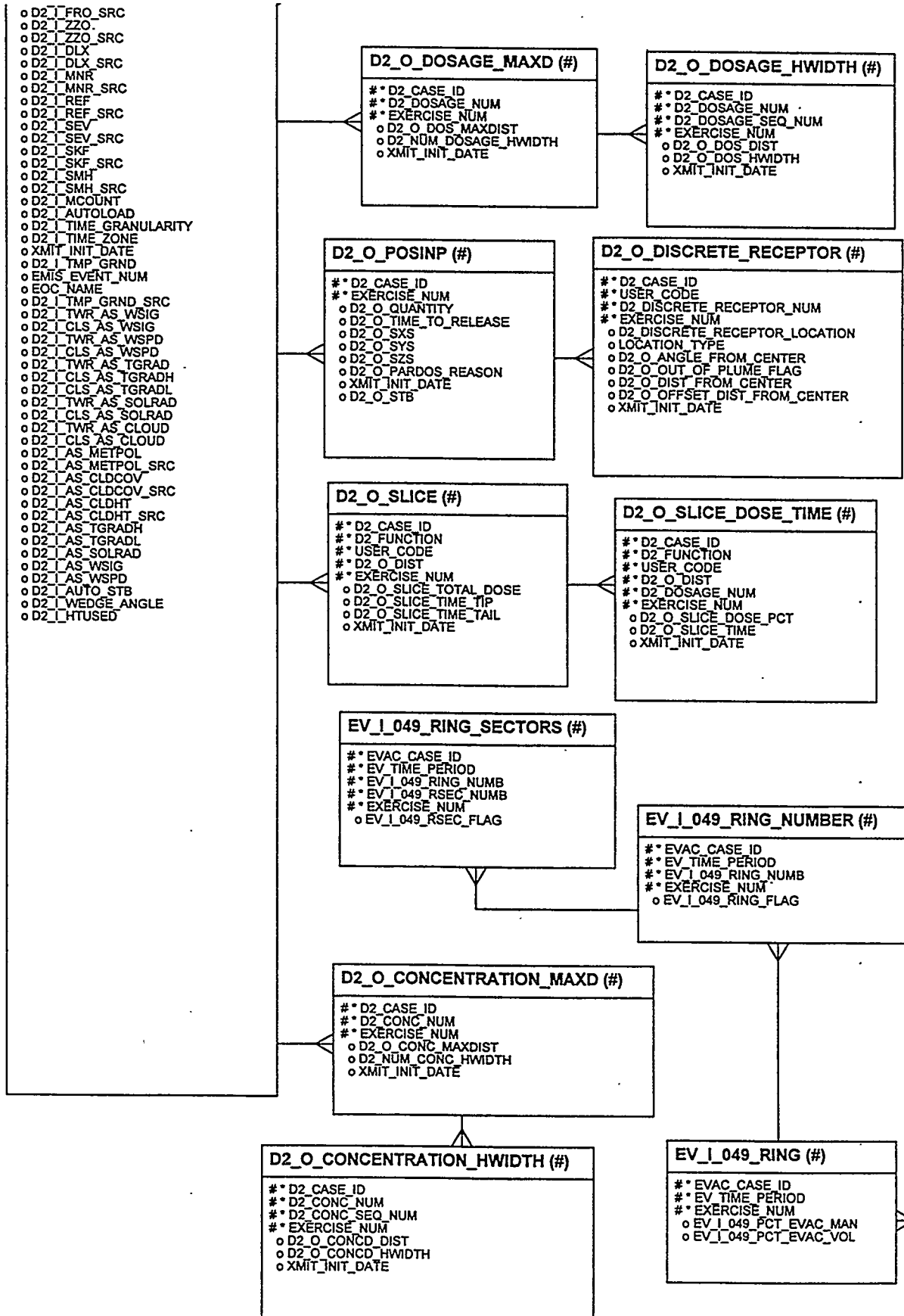

@ HBS_YESNO6
 @ UDS_YESNO7
 @ UDS_YESNO8
 @ UDS_YESNO9
 @ UDS_YESNO10
 @ UDS_YESNO11
 @ UDS_YESNO12
 @ UDS_YESNO13
 @ UDS_YESNO14
 @ UDS_YESNO15
 @ UDS_YESNO16
 @ UDS_YESNO17
 @ UDS_YESNO18
 @ UDS_YESNO19
 @ UDS_YESNO20
 @ UDS_LOCATION1
 @ UDS_LOCATION2
 @ UDS_LOCATION3
 @ UDS_LOCATION4
 @ UDS_LOCATION5
 @ UDS_ROW_CREATE_DATE
 @ UDS_ROW_MOD_DATE
 @ UDS_ACTUAL_TIME
 @ CURRENT_RECORD_FLAG
 @ UPDATE_PERSON_REF_NUM
 @ UDS_HISTORY_LINK_ID
 @ RECORD_FORMAT
 @ REVISION_NUM
 @ XMIT_INIT_DATE
 @ EXTRA_ATTRIBUTES
 @ MOD_COUNT
 @ MOD_USERNAME
 @ MOD_USERCODE
 @ MOD_DATE

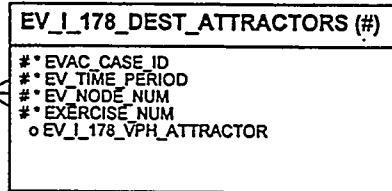
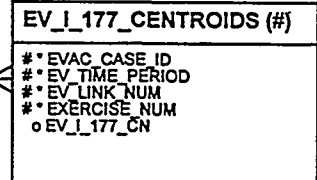
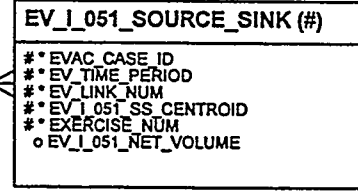
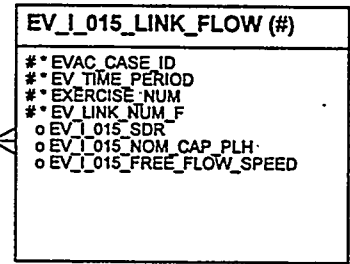
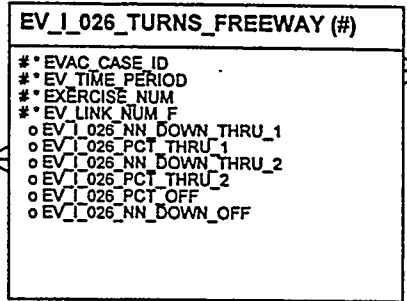
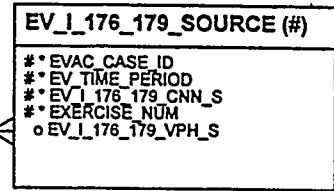
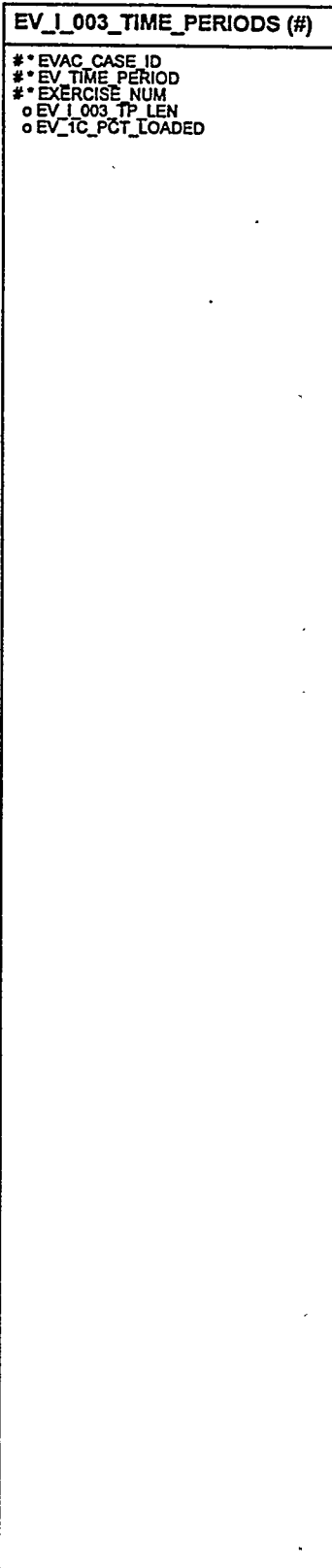

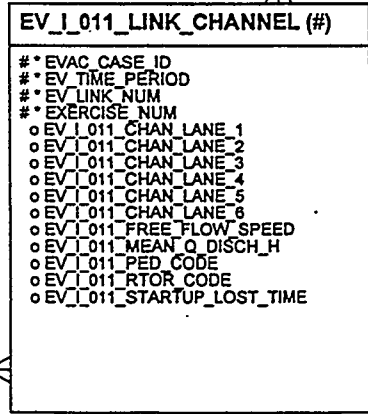
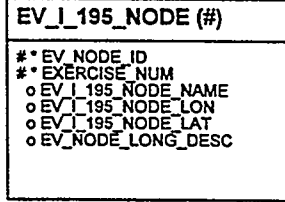
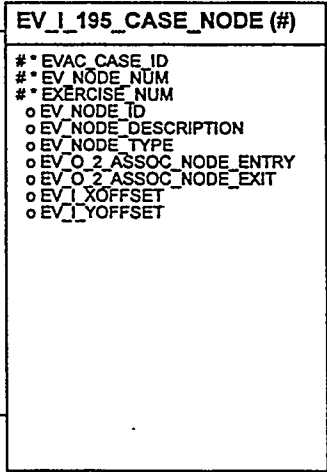
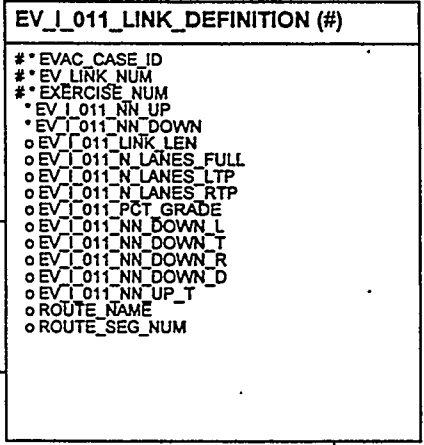
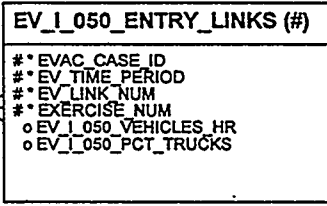
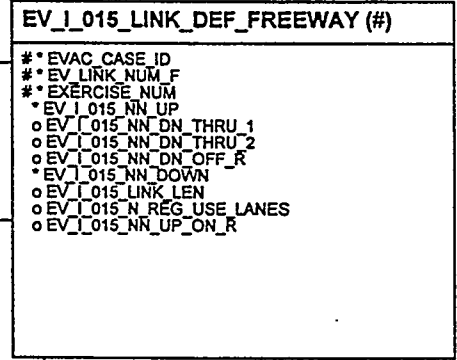
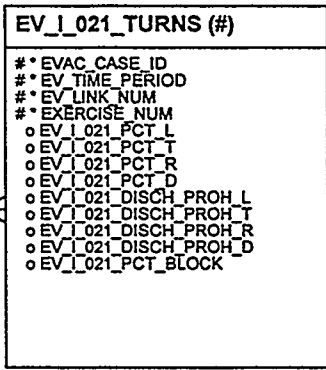
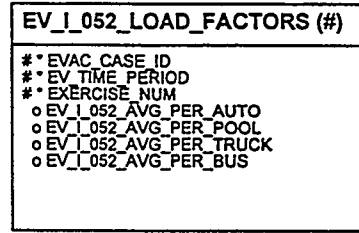
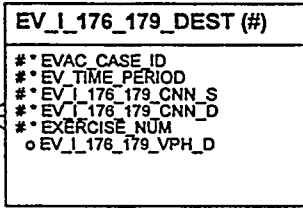

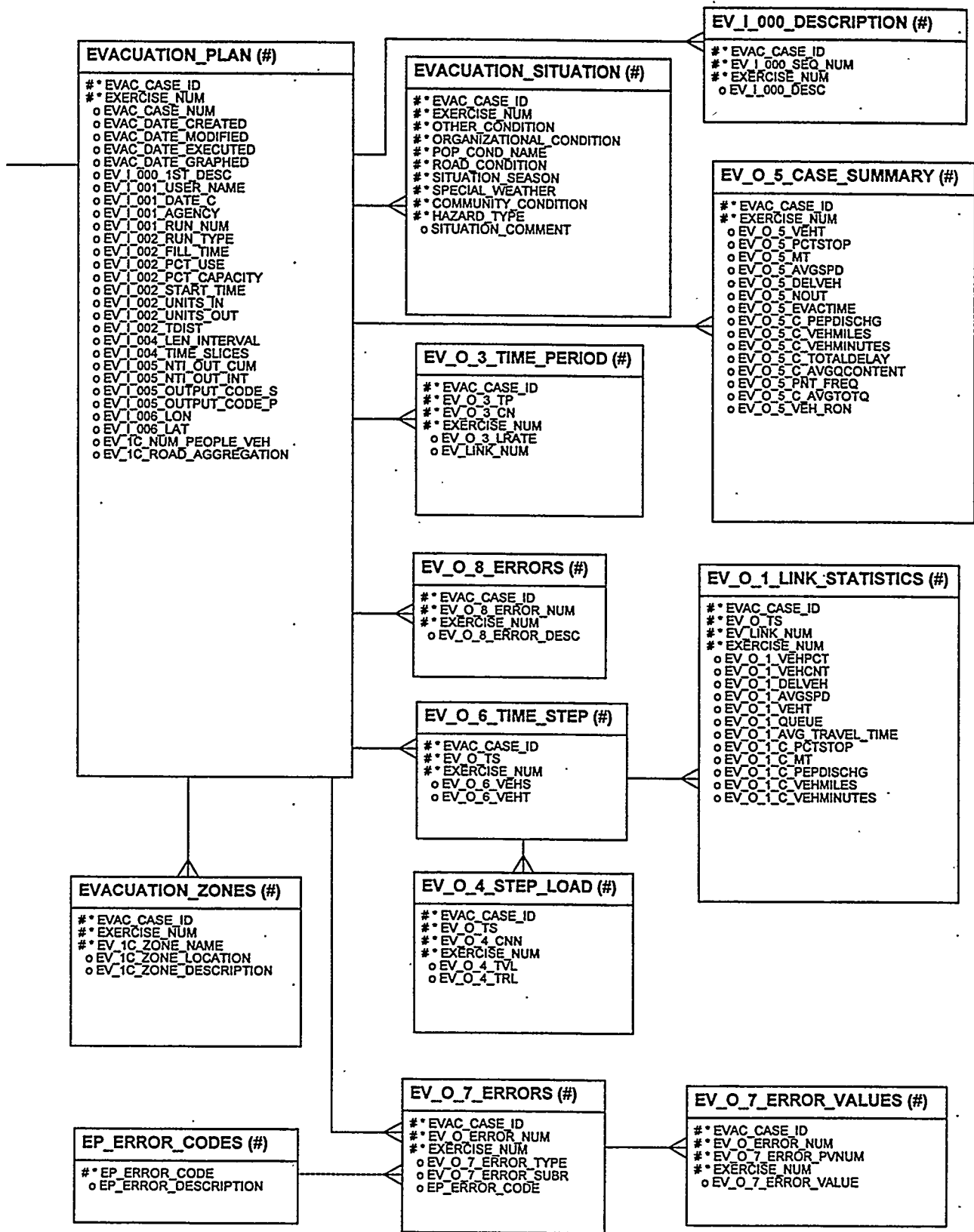

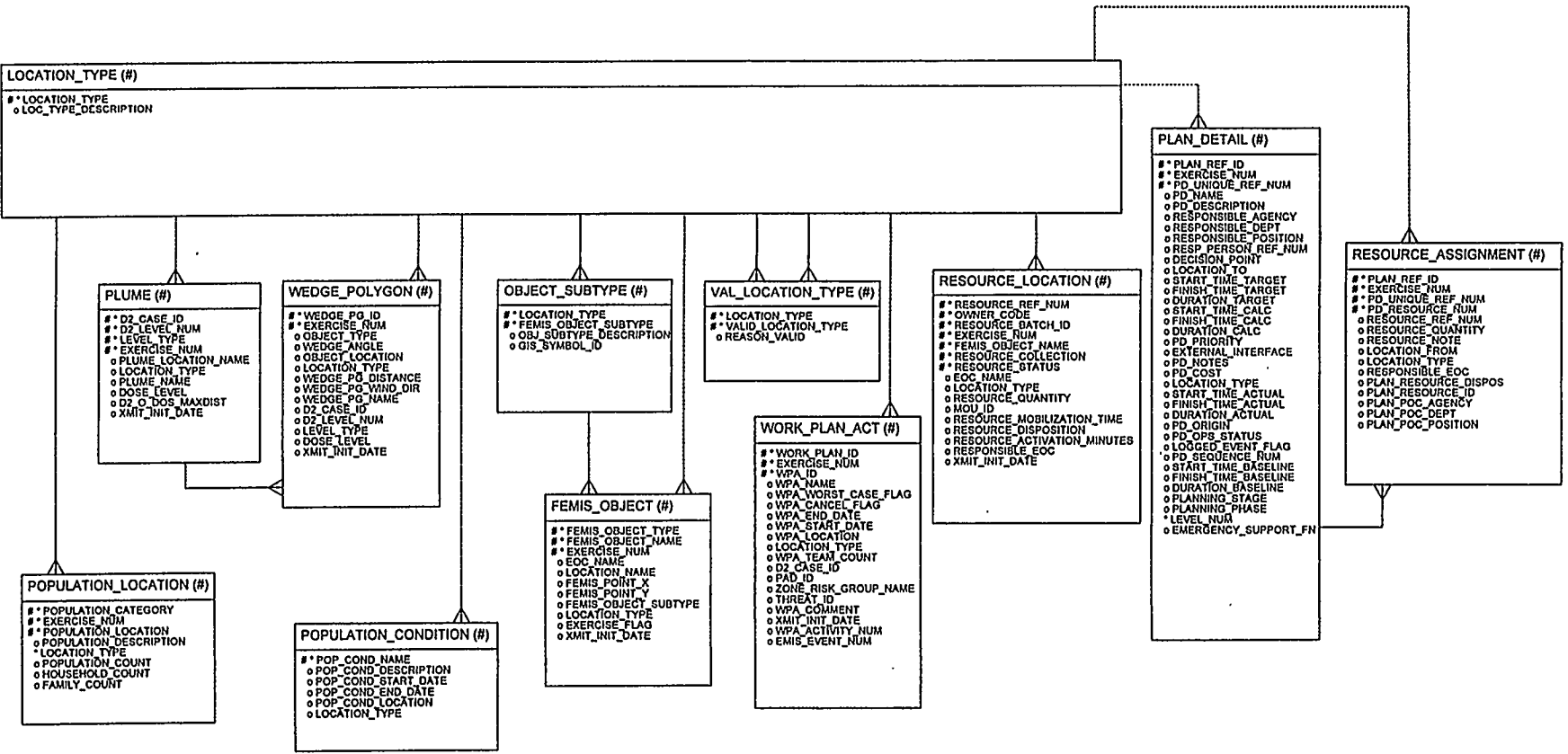

Appendix D
FEMIS Data Dictionary

Appendix D – FEMIS Data Dictionary

For the FEMIS data dictionary, the following lists the table name (in bold), a description of the table, and the fields of the table.

The Sequence is the order of the field in each table; the Name is the name of the field; the N heading is the null field, where N means not null and Y means null; and the Format shows the Oracle data format of the field.

Table Name

ACCIDENT_CLASS

The Accident Class table is a validation table for different types of accidents.

Sequence	Name	N	Format
1	ACCIDENT_CLASS	N	VARCHAR2 (20)
2	ACCIDENT_CLASS_DESCRIPTION	Y	VARCHAR2 (127)

Table Name

ACTIVITY

The Activity table contains a list of valid CSEPP activities.

Sequence	Name	N	Format
1	ACTIVITY_CODE	N	VARCHAR2 (20)
2	ACTIVITY_DESCRIPTION	Y	VARCHAR2 (127)

Table Name

AGENCY

The Agency table contains CSEPP agencies and other agencies that are important to the mission of FEMIS.

Sequence	Name	N	Format
1	AGENCY_CODE	N	NUMBER (9,0)
2	EXERCISE_NUM	N	NUMBER (9,0)
3	AGENCY_NAME	Y	VARCHAR2 (64)
4	AGENCY_TYPE	Y	VARCHAR2 (20)
5	AGENCY_ACRONYM	Y	VARCHAR2 (20)
6	EOC_NAME	Y	VARCHAR2 (30)
7	STREET_ADDRESS1	Y	VARCHAR2 (40)
8	STREET_ADDRESS2	Y	VARCHAR2 (40)
9	CITY_NAME	Y	VARCHAR2 (20)
10	STATE_CODE	Y	VARCHAR2 (2)
11	ZIP_CODE	Y	VARCHAR2 (10)
12	MAIN_PHONE	Y	VARCHAR2 (30)
13	FAX_PHONE	Y	VARCHAR2 (30)
14	CEL_PHONE	Y	VARCHAR2 (30)
15	BEEPER_PHONE	Y	VARCHAR2 (30)
16	EMAIL_ADDRESS	Y	VARCHAR2 (80)

17	EMAIL_ADDRESS2	Y	VARCHAR2(80)
18	WEB_ADDRESS	Y	VARCHAR2(255)
19	XMIT_INIT_DATE	Y	DATE 7

Table Name

AGENT_MUNITION

The Agent Munition table maintains combinations of agents and munitions.

Sequence	Name	N	Format
1	AGENT_CODE	N	VARCHAR2(2)
2	MUNITION_TYPE	N	VARCHAR2(4)
3	QUANTITY_PER_MUNITION	Y	NUMBER(13,2)

Table Name

APPROACH

The Approach table has a list of valid approaches to accomplish the mission of FEMIS.

Sequence	Name	N	Format
1	PLANNING_APPROACH	N	VARCHAR2(40)
2	PLAN_APP_DESCRIPTION	Y	VARCHAR2(127)

Table Name

BTB_DEPENDENCE

Sequence	Name	N	Format
1	PLAN_REF_ID	N	NUMBER(9,0)
2	EXERCISE_NUM	N	NUMBER(9,0)
3	PD_UNIQUE_REF_NUM	N	NUMBER(7,0)
4	PRED_PLAN_REF_ID	N	NUMBER(9,0)
5	PRED_PD_UNIQUE_REF_NUM	N	NUMBER(7,0)
6	DEPENDENCY_TYPE	Y	VARCHAR2(10)
7	LEAD_LAG_TIME	Y	NUMBER(6,2)

Table Name

BTB_PLAN_DETAIL

Sequence	Name	N	Format
1	PLAN_REF_ID	N	NUMBER(9,0)
2	EXERCISE_NUM	N	NUMBER(9,0)
3	PD_UNIQUE_REF_NUM	N	NUMBER(7,0)
4	PD_NAME	Y	VARCHAR2(254)
5	PD_DESCRIPTION	Y	VARCHAR2(2000)
6	RESPONSIBLE_AGENCY	Y	NUMBER(9,0)
7	RESPONSIBLE_DEPT	Y	NUMBER(9,0)
8	RESPONSIBLE_POSITION	Y	VARCHAR2(20)
9	RESP_PERSON_REF_NUM	Y	NUMBER(9,0)
10	DECISION_POINT	Y	VARCHAR2(1)
11	LOCATION_TO	Y	VARCHAR2(30)
12	START_TIME_TARGET	Y	DATE 7
13	FINISH_TIME_TARGET	Y	DATE 7

14	DURATION_TARGET	Y	NUMBER(8,0)
15	START_TIME_CALC	Y	DATE 7
16	FINISH_TIME_CALC	Y	DATE 7
17	DURATION_CALC	Y	NUMBER(8,0)
18	PD_PRIORITY	Y	NUMBER(2,0)
19	EXTERNAL_INTERFACE	Y	VARCHAR2(1)
20	PD_NOTES	Y	VARCHAR2(1999)
21	PD_COST	Y	NUMBER(10,2)
22	LOCATION_TYPE	Y	VARCHAR2(8)
23	START_TIME_ACTUAL	Y	DATE 7
24	FINISH_TIME_ACTUAL	Y	DATE 7
25	DURATION_ACTUAL	Y	NUMBER(8,0)
26	PD_ORIGIN	Y	VARCHAR2(10)
27	PD_OPS_STATUS	Y	VARCHAR2(15)
28	LOGGED_EVENT_FLAG	Y	VARCHAR2(1)
29	PD_SEQUENCE_NUM	Y	NUMBER(10,0)
30	START_TIME_BASELINE	Y	DATE 7
31	FINISH_TIME_BASELINE	Y	DATE 7
32	DURATION_BASELINE	Y	NUMBER(8,0)
33	PLANNING_STAGE	Y	VARCHAR2(30)
34	PLANNING_PHASE	Y	VARCHAR2(20)
35	LEVEL_NUM	N	NUMBER(1,0)
36	EMERGENCY_SUPPORT_FN	Y	VARCHAR2(30)

Table Name

BTB_PLAN_HEADER

Sequence	Name	N	Format
1	PLAN_REF_ID	N	NUMBER(9,0)
2	EXERCISE_NUM	N	NUMBER(9,0)
3	PLAN_CHANGE_DATE	Y	DATE 7
4	PLAN_NAME	N	VARCHAR2(64)
5	PLAN_STATUS	Y	VARCHAR2(11)
6	EOC_NAME	Y	VARCHAR2(30)
7	PLAN_DESCRIPTION	Y	VARCHAR2(254)
8	MAX_TASK_REF_NUM	Y	NUMBER(7,0)
9	MAX_TASK_SEQUENCE_NUM	Y	NUMBER(10,0)
10	PLAN_NOTE	Y	VARCHAR2(1999)
11	METHOD_TYPE	Y	VARCHAR2(20)
12	PLANNING_APPROACH	Y	VARCHAR2(40)
13	PLANNING_GOAL	Y	VARCHAR2(40)
14	HAZARD_ID	Y	NUMBER(9,0)

Table Name

BTB_RESOURCE_ASSIGNMENT

Sequence	Name	N	Format
1	PLAN_REF_ID	N	NUMBER(9,0)
2	EXERCISE_NUM	N	NUMBER(9,0)
3	PD_UNIQUE_REF_NUM	N	NUMBER(7,0)
4	PD_RESOURCE_NUM	N	NUMBER(3,0)
5	RESOURCE_REF_NUM	Y	NUMBER(9,0)
6	RESOURCE_QUANTITY	Y	NUMBER(10,0)

7	RESOURCE_NOTE	Y	VARCHAR2(127)
8	LOCATION_FROM	Y	VARCHAR2(30)
9	LOCATION_TYPE	Y	VARCHAR2(8)
10	RESPONSIBLE_EOC	Y	VARCHAR2(30)
11	PLAN_RESOURCE_DISPOS	Y	VARCHAR2(30)
12	PLAN_RESOURCE_ID	Y	NUMBER(9,0)
13	PLAN_POC_AGENCY	Y	NUMBER(9,0)
14	PLAN_POC_DEPT	Y	NUMBER(9,0)
15	PLAN_POC_POSITION	Y	VARCHAR2(30)

Table Name

BUNKER

The Bunker table contains information about the sites where chemical weapons are stored.

Sequence	Name	N	Format
1	BUNKER_NAME	N	VARCHAR2(30)
2	BUNKER_CODE	N	VARCHAR2(7)
3	SITE_NAME	Y	VARCHAR2(30)
4	XMIT_INIT_DATE	Y	DATE 7

Table Name

CASE_CISCO

The Case Check-in-check_out table contains information about case that are in use.

Sequence	Name	N	Format
1	CASE_TYPE	N	VARCHAR2(4)
2	CASE_ID	N	NUMBER(9,0)
3	EXERCISE_NUM	N	NUMBER(9,0)
4	USER_CODE	Y	VARCHAR2(8)
5	PRIVATE_FLAG	Y	VARCHAR2(1)
6	COMPLETE_FLAG	Y	VARCHAR2(1)
7	CO_FLAG	Y	VARCHAR2(1)

Table Name

CASUALTY

The Casualty table contains summary information about the victims of an accident.

Sequence	Name	N	Format
1	VIC_TK_REF_NUM	N	NUMBER(9,0)
2	CASUALTY_MOD_DATE	N	DATE 7
3	EXERCISE_NUM	N	NUMBER(9,0)
4	INJURY_CODE	Y	VARCHAR2(20)
5	OK_RELEASE_FLAG	Y	VARCHAR2(1)
6	CASUALTY_LOCATION	Y	VARCHAR2(92)
7	LOCATION_TYPE	Y	VARCHAR2(8)
8	INJURY_NOTES	Y	VARCHAR2(2000)
9	CONTAMINATED_IND	Y	VARCHAR2(1)
10	FACILITY_TO	Y	VARCHAR2(30)
11	FACILITY_TYPE	Y	VARCHAR2(40)

12	CASUALTY_NOTE	Y VARCHAR2 (2000)
13	UPDATE_PERSON_REF_NUM	N NUMBER (9,0)
14	CASUALTY_STATUS_CODE	Y NUMBER (1,0)
15	VICTIM_HT_INCHES	Y NUMBER (3,0)
16	VICTIM_WT_LBS	Y NUMBER (3,0)
17	VICTIM_HAIR_COLOR	Y VARCHAR2 (10)
18	VICTIM_EYE_COLOR	Y VARCHAR2 (10)
19	VICTIM_RACE	Y VARCHAR2 (20)
20	VICTIM_OTHER_PHY_DESC	Y VARCHAR2 (255)
21	MED_COND_NOTES	Y VARCHAR2 (1999)
22	VICTIM_BADGE_NUM	Y VARCHAR2 (10)
23	VICTIM_EMP_NUM	Y VARCHAR2 (10)
24	VICTIM_AGENCY_CODE	Y NUMBER (9,0)
25	VICTIM_WORK_PHONE	Y VARCHAR2 (30)
26	WORK_STREET_ADDRESS1	Y VARCHAR2 (40)
27	WORK_STREET_ADDRESS2	Y VARCHAR2 (40)
28	WORK_CITY_NAME	Y VARCHAR2 (20)
29	WORK_STATE_CODE	Y VARCHAR2 (2)
30	WORK_ZIP_CODE	Y VARCHAR2 (10)
31	INJURY_DATE	Y DATE 7
32	VICTIM_KNOWN_MED_COND	Y VARCHAR2 (2000)
33	DECONTAM_FLAG	Y VARCHAR2 (1)
34	SEVERITY_CODE	Y VARCHAR2 (12)
35	INJURED_ONPOST_FLAG	Y VARCHAR2 (1)
36	NOK_NOTIFY_STATUS_FLAG	Y VARCHAR2 (1)
37	ACCIDENT_ID	Y NUMBER (9,0)
38	ACCIDENT_MOD_DATE	Y DATE 7
39	LOCATION_SUBTYPE	Y VARCHAR2 (40)
40	EOC_NAME	Y VARCHAR2 (30)

Table Name
CAS_INQUIRY

The Casualty Inquiry table contains information about accident inquiries.

Sequence	Name	N Format
1	VIC_TK_REF_NUM	N NUMBER (9,0)
2	CASUALTY_MOD_DATE	N DATE 7
3	EXERCISE_NUM	N NUMBER (9,0)
4	INQUIRY_ID	N NUMBER (9,0)
5	INQ_TK_REF_NUM	Y NUMBER (9,0)
6	INQ_NAME	Y VARCHAR2 (40)
7	INFO_REQUESTED	Y VARCHAR2 (255)
8	INFO_NOTES	Y VARCHAR2 (2000)
9	INFO_RELEASED_FLAG	Y VARCHAR2 (1)
10	INFO_RELEASE_DATE	N DATE 7
11	REL_PERSON_REF_NUM	Y NUMBER (9,0)

Table Name

CENSUS_BLOCK

The Census Block table defines a block name within a tract.

Sequence	Name	N	Format
1	TRACT_NAME	N	VARCHAR2 (30)
2	BLOCK_NAME	N	VARCHAR2 (30)
3	STATE_FIPS_CODE	N	VARCHAR2 (2)
4	COUNTY_FIPS_CODE	N	VARCHAR2 (3)
5	CENSUS_BLOCK_NAME	N	VARCHAR2 (30)

Table Name

CENSUS_SUBDIVISION

The Census Subdivision table defines a subdivision within a county.

Sequence	Name	N	Format
1	SUBDIVISION_NAME	N	VARCHAR2 (30)
2	STATE_FIPS_CODE	N	VARCHAR2 (2)
3	COUNTY_FIPS_CODE	N	VARCHAR2 (3)
4	CSD_NAME	N	VARCHAR2 (30)

Table Name

CENSUS_TRACT

The Census Tract table defines a tract within a district.

Sequence	Name	N	Format
1	TRACT_NAME	N	VARCHAR2 (30)
2	STATE_FIPS_CODE	N	VARCHAR2 (2)
3	COUNTY_FIPS_CODE	N	VARCHAR2 (3)
4	CENSUS_TRACT_NAME	N	VARCHAR2 (30)

Table Name

CHEMICAL_AGENT

The Chemical Agent table describes the agents stored at a CSEPP site.

Sequence	Name	N	Format
1	AGENT_CODE	N	VARCHAR2 (2)
2	AGENT_TYPE	Y	VARCHAR2 (30)
3	AGENT_DESCRIPTION	Y	VARCHAR2 (127)

Table Name

CONTROL_POINT

The Control Point table contains the software branch points used to control user access privileges.

Sequence	Name	N	Format
1	CP_NAME	N	VARCHAR2 (60)
2	CP_DESCRIPTION	Y	VARCHAR2 (127)
3	CP_TYPE	N	VARCHAR2 (30)

4	HAZARD_ID	Y NUMBER(9,0)
5	XMIT_INIT_DATE	Y DATE 7

Table Name
COUNTY

The County table contains the name of counties and the state they are in.

Sequence	Name	N Format
1	STATE_FIPS_CODE	N VARCHAR2(2)
2	COUNTY_FIPS_CODE	N VARCHAR2(3)
3	COUNTY_NAME	Y VARCHAR2(30)
4	STATE_CODE	Y VARCHAR2(2)

Table Name
CSEPP_ACCIDENT

The CSEPP_Accident table describes the chemical or other type of accident that has occurred.

Sequence	Name	N Format
1	ACCIDENT_ID	N NUMBER(9,0)
2	ACCIDENT_MOD_DATE	N DATE 7
3	EXERCISE_NUM	N NUMBER(9,0)
4	ACCIDENT_DESCRIPTION	Y VARCHAR2(127)
5	ACCIDENT_DATE	N DATE 7
6	UPDATE_PERSON_REF_NUM	Y NUMBER(9,0)
7	ACCIDENT_COMMENT	Y VARCHAR2(1999)
8	ACCIDENT_CLOSED_DATE	Y DATE 7
9	ACCIDENT_IN_PROG_FLAG	N VARCHAR2(1)
10	CAI_STATUS_CODE	N NUMBER(1,0)
11	CAI_DECLARING_EOC	N VARCHAR2(30)
12	D2_CASE_ID	Y NUMBER(9,0)
13	ACTIVITY_CODE	Y VARCHAR2(20)
14	ACCIDENT_CLASS	Y VARCHAR2(20)
15	XMIT_INIT_DATE	Y DATE 7
16	EMIS_EVENT_NUM	Y NUMBER(4,0)
17	ACCIDENT_ACTUAL_DATE	Y DATE 7
18	SET_ACCIDENT_FLAG	Y VARCHAR2(1)
19	ACCIDENT_ACTION	Y VARCHAR2(256)
20	UPDATE_USER_NAME	Y VARCHAR2(48)
21	UPDATE_USER_CODE	Y VARCHAR2(8)

Table Name
D2_INPUT

The table that contains common D2 input parameters and other control information.

Sequence	Name	N Format
1	D2_CASE_ID	N NUMBER(9,0)
2	EXERCISE_NUM	N NUMBER(9,0)
3	D2_CASE_NUM	Y NUMBER(9,0)
4	D2_I_EVENT_DT	Y VARCHAR2(28)
5	D2_I_EVENT_IA	Y NUMBER(12,6)

6	D2_I_EVENT_LO	Y NUMBER(12,6)
7	D2_I_IGLOO	Y VARCHAR2(30)
8	D2_I_DISTANCE_FROM_IGLOO	Y NUMBER(8,2)
9	D2_I_DIRECTION_FROM_IGLOO	Y VARCHAR2(2)
10	D2_I_MOD_DT	Y VARCHAR2(28)
11	D2_I_DESC	Y VARCHAR2(127)
12	D2_I_TWR_STAB	Y VARCHAR2(9)
13	D2_I_CLS_STAB	Y NUMBER(2,0)
14	D2_I_TWR_WSPD	Y VARCHAR2(9)
15	D2_I_CLS_WSPD	Y NUMBER(2,0)
16	D2_I_TWR_WDIR	Y VARCHAR2(9)
17	D2_I_CLS_WDIR	Y NUMBER(2,0)
18	D2_I_TWR_TEMP	Y VARCHAR2(9)
19	D2_I_CLS_TEMP	Y NUMBER(2,0)
20	D2_I_TWR_ATMP	Y VARCHAR2(9)
21	D2_I_CLS_ATMP	Y NUMBER(2,0)
22	D2_I_TWR_CLDH	Y VARCHAR2(9)
23	D2_I_CLS_CLDH	Y NUMBER(2,0)
24	D2_I_TWR_HMLR	Y VARCHAR2(9)
25	D2_I_CLS_HMLR	Y NUMBER(2,0)
26	D2_I_NOV	Y NUMBER(1,0)
27	D2_I_NOV_SRC	Y VARCHAR2(1)
28	D2_I_LOC	Y VARCHAR2(3)
29	D2_I_LOC_SRC	Y VARCHAR2(1)
30	D2_I_SEA	Y VARCHAR2(3)
31	D2_I_SEA_SRC	Y VARCHAR2(1)
32	D2_I_AGN	Y VARCHAR2(2)
33	D2_I_AGN_SRC	Y VARCHAR2(1)
34	D2_I_TMP	Y NUMBER(8,4)
35	D2_I_TMP_SRC	Y VARCHAR2(1)
36	D2_I_VDP	Y NUMBER(1,0)
37	D2_I_VDP_SRC	Y VARCHAR2(1)
38	D2_I_OPO	Y NUMBER(1,0)
39	D2_I_OPO_SRC	Y VARCHAR2(1)
40	D2_I_PMM	Y NUMBER(6,2)
41	D2_I_PMM_SRC	Y VARCHAR2(1)
42	D2_I_BRT	Y NUMBER(6,2)
43	D2_I_BRT_SRC	Y VARCHAR2(1)
44	D2_I_2MC	Y NUMBER(1,0)
45	D2_I_2MC_SRC	Y VARCHAR2(1)
46	D2_I_NDI	Y NUMBER(2,0)
47	D2_I_NDI_SRC	Y VARCHAR2(1)
48	D2_I_IMA	Y NUMBER(1,0)
49	D2_I_IMA_SRC	Y VARCHAR2(1)
50	D2_I_NCI	Y NUMBER(2,0)
51	D2_I_NCI_SRC	Y VARCHAR2(1)
52	D2_I_IYR	Y NUMBER(4,0)
53	D2_I_IYR_SRC	Y VARCHAR2(1)
54	D2_I_MON	Y VARCHAR2(3)
55	D2_I_MON_SRC	Y VARCHAR2(1)
56	D2_I_IDD	Y NUMBER(2,0)
57	D2_I_IDD_SRC	Y VARCHAR2(1)
58	D2_I_HRS	Y NUMBER(4,0)
59	D2_I_HRS_SRC	Y VARCHAR2(1)
60	D2_I_CCT	Y NUMBER(2,0)

61	D2_I_CCT_SRC	Y VARCHAR2 (1)
62	D2_I_CHT	Y NUMBER (8,2)
63	D2_I_CHT_SRC	Y VARCHAR2 (1)
64	D2_I_ALF	Y NUMBER (6,2)
65	D2_I_ALF_SRC	Y VARCHAR2 (1)
66	D2_I_SYR	Y NUMBER (6,2)
67	D2_I_SYR_SRC	Y VARCHAR2 (1)
68	D2_I_BTA	Y NUMBER (6,2)
69	D2_I_BTA_SRC	Y VARCHAR2 (1)
70	D2_I_SZR	Y NUMBER (6,2)
71	D2_I_SZR_SRC	Y VARCHAR2 (1)
72	D2_I_WOO	Y VARCHAR2 (2)
73	D2_I_WOO_SRC	Y VARCHAR2 (1)
74	D2_I_FMW	Y NUMBER (6,3)
75	D2_I_FMW_SRC	Y VARCHAR2 (1)
76	D2_I_FMV	Y NUMBER (6,3)
77	D2_I_FMV_SRC	Y VARCHAR2 (1)
78	D2_I_DN25	Y NUMBER (6,3)
79	D2_I_DN25_SRC	Y VARCHAR2 (1)
80	D2_I_VAP	Y NUMBER (6,3)
81	D2_I_VAP_SRC	Y VARCHAR2 (1)
82	D2_I_BPT	Y NUMBER (6,2)
83	D2_I_BPT_SRC	Y VARCHAR2 (1)
84	D2_I_ANA	Y NUMBER (6,2)
85	D2_I_ANA_SRC	Y VARCHAR2 (1)
86	D2_I_ANB	Y NUMBER (6,2)
87	D2_I_ANB_SRC	Y VARCHAR2 (1)
88	D2_I_ANC	Y NUMBER (6,2)
89	D2_I_ANC_SRC	Y VARCHAR2 (1)
90	D2_I_FRZ	Y NUMBER (6,2)
91	D2_I_FRZ_SRC	Y VARCHAR2 (1)
92	D2_I_SLA	Y NUMBER (12,6)
93	D2_I_SLA_SRC	Y VARCHAR2 (1)
94	D2_I_SLO	Y NUMBER (12,6)
95	D2_I_SLO_SRC	Y VARCHAR2 (1)
96	D2_I_SUN	Y NUMBER (6,3)
97	D2_I_SUN_SRC	Y VARCHAR2 (1)
98	D2_I_FRO	Y NUMBER (6,3)
99	D2_I_FRO_SRC	Y VARCHAR2 (1)
100	D2_I_ZZO	Y NUMBER (7,3)
101	D2_I_ZZO_SRC	Y VARCHAR2 (1)
102	D2_I_DLX	Y NUMBER (6,2)
103	D2_I_DLX_SRC	Y VARCHAR2 (1)
104	D2_I_MNR	Y NUMBER (1,0)
105	D2_I_MNR_SRC	Y VARCHAR2 (1)
106	D2_I_REF	Y NUMBER (6,2)
107	D2_I_REF_SRC	Y VARCHAR2 (1)
108	D2_I_SEV	Y NUMBER (6,2)
109	D2_I_SEV_SRC	Y VARCHAR2 (1)
110	D2_I_SKF	Y NUMBER (6,3)
111	D2_I_SKF_SRC	Y VARCHAR2 (1)
112	D2_I_SMH	Y NUMBER (8,2)
113	D2_I_SMH_SRC	Y VARCHAR2 (1)
114	D2_I_MCOUNT	Y NUMBER (3,0)
115	D2_I_AUTOLOAD	Y VARCHAR2 (1)

116	D2_I_TIME_GRANULARITY	Y NUMBER(3,0)
117	D2_I_TIME_ZONE	Y VARCHAR2(4)
118	XMIT_INIT_DATE	Y DATE 7
119	D2_I_TMP_GRND	Y NUMBER(8,4)
120	EMIS_EVENT_NUM	Y NUMBER(4,0)
121	EOC_NAME	Y VARCHAR2(30)
122	D2_I_TMP_GRND_SRC	Y VARCHAR2(1)
123	D2_I_TWR_AS_WSIG	Y VARCHAR2(9)
124	D2_I_CLS_AS_WSIG	Y NUMBER(2,0)
125	D2_I_TWR_AS_WSPD	Y VARCHAR2(9)
126	D2_I_CLS_AS_WSPD	Y NUMBER(2,0)
127	D2_I_TWR_AS_TGRAD	Y VARCHAR2(9)
128	D2_I_CLS_AS_TGRADH	Y NUMBER(2,0)
129	D2_I_CLS_AS_TGRADL	Y NUMBER(2,0)
130	D2_I_TWR_AS_SOLRAD	Y VARCHAR2(9)
131	D2_I_CLS_AS_SOLRAD	Y NUMBER(2,0)
132	D2_I_TWR_AS_CLOUD	Y VARCHAR2(9)
133	D2_I_CLS_AS_CLOUD	Y NUMBER(2,0)
134	D2_I_AS_METPOL	Y NUMBER(6,1)
135	D2_I_AS_METPOL_SRC	Y VARCHAR2(1)
136	D2_I_AS_CLDCOV	Y NUMBER(2,0)
137	D2_I_AS_CLDCOV_SRC	Y VARCHAR2(1)
138	D2_I_AS_CLDHT	Y NUMBER(8,2)
139	D2_I_AS_CLDHT_SRC	Y VARCHAR2(1)
140	D2_I_AS_TGRADH	Y NUMBER(8,4)
141	D2_I_AS_TGRADL	Y NUMBER(8,4)
142	D2_I_AS_SOLRAD	Y NUMBER(7,2)
143	D2_I_AS_WSIG	Y NUMBER(9,2)
144	D2_I_AS_WSPD	Y NUMBER(6,3)
145	D2_I_AUTO_STB	Y VARCHAR2(1)
146	D2_I_WEDGE_ANGLE	Y NUMBER(3)
147	D2_I_HTUSED	Y VARCHAR2(1)

Table Name

D2_ITEM_OF_INTEREST

This table contains D2 input parameters and other control information.

Sequence	Name	N Format
1	D2_CASE_ID	N NUMBER(9,0)
2	D2_TIME_STEP	N NUMBER(4,0)
3	D2_ITEM_OF_INTEREST	N VARCHAR2(6)
4	EXERCISE_NUM	N NUMBER(9,0)
5	D2_C_DISTANCE	Y NUMBER(6,0)
6	XMIT_INIT_DATE	Y DATE 7

Table Name

D2_I_CONCENTRATION

This table contains D2 input parameters and other control information.

Sequence	Name	N Format
1	D2_CASE_ID	N NUMBER(9,0)
2	D2_CONC_NUM	N NUMBER(3,0)
3	EXERCISE_NUM	N NUMBER(9,0)

4	D2_I_CONC_CI	Y NUMBER(15,9)
5	D2_I_CONC_CI_D	Y VARCHAR2(127)
6	D2_I_CONC_CI_SRC	Y VARCHAR2(1)
7	D2_I_CONC_CI_D_SRC	Y VARCHAR2(1)
8	XMIT_INIT_DATE	Y DATE 7

Table Name

D2_I_DOSAGE

This table contains D2 input parameters and other control information.

Sequence	Name	N Format
1	D2_CASE_ID	N NUMBER(9,0)
2	D2_DOSAGE_NUM	N NUMBER(2,0)
3	EXERCISE_NUM	N NUMBER(9,0)
4	D2_I_DOSAGE_DI	Y NUMBER(15,9)
5	D2_I_DOSAGE_DI_D	Y VARCHAR2(127)
6	D2_I_DOSAGE_DI_SRC	Y VARCHAR2(1)
7	D2_I_DOSAGE_DI_D_SRC	Y VARCHAR2(1)
8	XMIT_INIT_DATE	Y DATE 7

Table Name

D2_I_MET

This table contains D2 input parameters and other control information.

Sequence	Name	N Format
1	D2_CASE_ID	N NUMBER(9,0)
2	D2_I_MET_NUM	N NUMBER(3,0)
3	EXERCISE_NUM	N NUMBER(9,0)
4	D2_I_MET_STB	Y VARCHAR2(1)
5	D2_I_MET_HML	Y NUMBER(8,2)
6	D2_I_MET_WND	Y NUMBER(6,3)
7	D2_I_MET_W_D	Y NUMBER(6,3)
8	D2_I_MET_TMC	Y NUMBER(6,2)
9	D2_I_MET_STB_SRC	Y VARCHAR2(1)
10	D2_I_MET_HML_SRC	Y VARCHAR2(1)
11	D2_I_MET_WND_SRC	Y VARCHAR2(1)
12	D2_I_MET_W_D_SRC	Y VARCHAR2(1)
13	D2_I_MET_TMC_SRC	Y VARCHAR2(1)
14	XMIT_INIT_DATE	Y DATE 7

Table Name

D2_I_QUANTITY

This table contains D2 input parameters and other control information.

Sequence	Name	N Format
1	D2_CASE_ID	N NUMBER(9,0)
2	D2_REL_NUM	N NUMBER(3,0)
3	D2_I_QUAN_NUM	N NUMBER(2,0)
4	EXERCISE_NUM	N NUMBER(9,0)
5	D2_I_QUAN_Q	Y NUMBER(13,2)
6	D2_I_QUAN_QT	Y NUMBER(6,2)
7	D2_I_QUAN_Q_SRC	Y VARCHAR2(1)

8 D2_I_QUAN_QT_SRC Y VARCHAR2(1)
9 XMIT_INIT_DATE Y DATE 7

Table Name

D2_I_RELEASE_NUM

This table contains D2 input parameters and other control information.

Sequence	Name	N Format
1	D2_CASE_ID	N NUMBER(9,0)
2	D2_REL_NUM	N NUMBER(3,0)
3	EXERCISE_NUM	N NUMBER(9,0)
4	D2_I_MUN	Y VARCHAR2(3)
5	D2_I_MUN_SRC	Y VARCHAR2(1)
6	D2_I_REL	Y VARCHAR2(3)
7	D2_I_REL_SRC	Y VARCHAR2(1)
8	D2_I_NMU	Y NUMBER(6,2)
9	D2_I_NMU_SRC	Y VARCHAR2(1)
10	D2_I_NQI	Y NUMBER(1,0)
11	D2_I_NQI_SRC	Y VARCHAR2(1)
12	D2_I_TEV	Y NUMBER(6,2)
13	D2_I_TEV_SRC	Y VARCHAR2(1)
14	D2_I_SUR	Y VARCHAR2(3)
15	D2_I_SUR_SRC	Y VARCHAR2(1)
16	D2_I_ARE	Y NUMBER(7,3)
17	D2_I_ARE_SRC	Y VARCHAR2(1)
18	D2_I_LEN	Y NUMBER(7,3)
19	D2_I_LEN_SRC	Y VARCHAR2(1)
20	D2_I_OPC	Y NUMBER(1,0)
21	D2_I_OPC_SRC	Y VARCHAR2(1)
22	D2_I_HST	Y NUMBER(7,3)
23	D2_I_HST_SRC	Y VARCHAR2(1)
24	D2_I_DST	Y NUMBER(7,3)
25	D2_I_DST_SRC	Y VARCHAR2(1)
26	D2_I_TST	Y NUMBER(6,3)
27	D2_I_TST_SRC	Y VARCHAR2(1)
28	D2_I_VST	Y NUMBER(6,3)
29	D2_I_VST_SRC	Y VARCHAR2(1)
30	D2_I_RDE	Y NUMBER(6,3)
31	D2_I_RDE_SRC	Y VARCHAR2(1)
32	D2_I_HRL	Y NUMBER(11,2)
33	D2_I_HRL_SRC	Y VARCHAR2(1)
34	D2_I_CRD	Y NUMBER(8,2)
35	D2_I_CRD_SRC	Y VARCHAR2(1)
36	D2_I_QQQ	Y NUMBER(13,2)
37	D2_I_QQQ_SRC	Y VARCHAR2(1)
38	D2_I_HTS	Y NUMBER(8,2)
39	D2_I_HTS_SRC	Y VARCHAR2(1)
40	D2_I_SXS	Y NUMBER(8,2)
41	D2_I_SXS_SRC	Y VARCHAR2(1)
42	D2_I_SYS	Y NUMBER(8,2)
43	D2_I_SYS_SRC	Y VARCHAR2(1)
44	D2_I_SZS	Y NUMBER(8,2)
45	D2_I_SZS_SRC	Y VARCHAR2(1)
46	D2_I_TIM	Y NUMBER(6,2)

47 D2_I_TIM_SRC Y VARCHAR2(1)
48 XMIT_INIT_DATE Y DATE 7

Table Name

D2_MET_SELECTION

This table determines which combination of met parameters are used.

Sequence	Name	N Format
1	MET_PARAM_CODE	N VARCHAR2(2)
2	MET_ID	N NUMBER(9,0)
3	EXERCISE_NUM	N NUMBER(9,0)
4	CURRENT_FLAG	N VARCHAR2(1)
5	TOWER_NAME	N VARCHAR2(30)
6	WX_TIME_VALID	N DATE 7
7	CLUSTER_NUM	N NUMBER(2,0)
8	XMIT_INIT_DATE	Y DATE 7

Table Name

D2_O_CONCENTRATION_HWIDTH

This table contains D2 output results.

Sequence	Name	N Format
1	D2_CASE_ID	N NUMBER(9,0)
2	D2_CONC_NUM	N NUMBER(3,0)
3	D2_CONC_SEQ_NUM	N NUMBER(4,0)
4	EXERCISE_NUM	N NUMBER(9,0)
5	D2_O_CONCD_DIST	Y NUMBER(10,2)
6	D2_O_CONCD_HWIDTH	Y NUMBER(10,2)
7	XMIT_INIT_DATE	Y DATE 7

Table Name

D2_O_CONCENTRATION_MAXD

This table contains D2 output results.

Sequence	Name	N Format
1	D2_CASE_ID	N NUMBER(9,0)
2	D2_CONC_NUM	N NUMBER(3,0)
3	EXERCISE_NUM	N NUMBER(9,0)
4	D2_O_CONC_MAXDIST	Y NUMBER(10,2)
5	D2_NUM_CONC_HWIDTH	Y NUMBER(4,0)
6	XMIT_INIT_DATE	Y DATE 7

Table Name

D2_O_DISCRETE_RECEPTOR

This table contains D2 output results.

Sequence	Name	N Format
1	D2_CASE_ID	N NUMBER(9,0)
2	USER_CODE	N VARCHAR2(7)
3	D2_DISCRETE_RECEPTOR_NUM	N NUMBER(4,0)
4	EXERCISE_NUM	N NUMBER(9,0)

5	D2_DISCRETE_RECEPTOR_LOCATION	Y VARCHAR2(92)
6	LOCATION_TYPE	Y VARCHAR2(4)
7	D2_O_ANGLE_FROM_CENTER	Y NUMBER(6,3)
8	D2_O_OUT_OF_PLUME_FLAG	Y VARCHAR2(3)
9	D2_O_DIST_FROM_CENTER	Y NUMBER(10,2)
10	D2_O_OFFSET_DIST_FROM_CENTER	Y NUMBER(10,2)
11	XMIT_INIT_DATE	Y DATE 7

Table Name

D2_O_DOSAGE_HWIDTH

This table contains D2 output results.

Sequence	Name	N Format
1	D2_CASE_ID	N NUMBER(9,0)
2	D2_DOSAGE_NUM	N NUMBER(2,0)
3	D2_DOSAGE_SEQ_NUM	N NUMBER(4,0)
4	EXERCISE_NUM	N NUMBER(9,0)
5	D2_O_DOS_DIST	Y NUMBER(10,2)
6	D2_O_DOS_HWIDTH	Y NUMBER(10,2)
7	XMIT_INIT_DATE	Y DATE 7

Table Name

D2_O_DOSAGE_MAXD

This table contains D2 output results.

Sequence	Name	N Format
1	D2_CASE_ID	N NUMBER(9,0)
2	D2_DOSAGE_NUM	N NUMBER(2,0)
3	EXERCISE_NUM	N NUMBER(9,0)
4	D2_O_DOS_MAXDIST	Y NUMBER(10,2)
5	D2_NUM_DOSAGE_HWIDTH	Y NUMBER(4,0)
6	XMIT_INIT_DATE	Y DATE 7

Table Name

D2_O_POSINP

This table contains D2 output results.

Sequence	Name	N Format
1	D2_CASE_ID	N NUMBER(9,0)
2	EXERCISE_NUM	N NUMBER(9,0)
3	D2_O_QUANTITY	Y NUMBER(13,2)
4	D2_O_TIME_TO_RELEASE	Y NUMBER(6,2)
5	D2_O_SXS	Y NUMBER(8,2)
6	D2_O_SYS	Y NUMBER(8,2)
7	D2_O_SZS	Y NUMBER(8,2)
8	D2_O_PARDOS_REASON	Y VARCHAR2(80)
9	XMIT_INIT_DATE	Y DATE 7
10	D2_O_STB	Y VARCHAR2(1)

Table Name
D2_O_RUN_DT

This table contains D2 output results.

Sequence	Name	N	Format
1	D2_CASE_ID	N	NUMBER(9,0)
2	EXERCISE_NUM	N	NUMBER(9,0)
3	D2_O_RUN_DT	Y	DATE 7
4	XMIT_INIT_DATE	Y	DATE 7

Table Name
D2_O_SLICE

This table contains D2 output results.

Sequence	Name	N	Format
1	D2_CASE_ID	N	NUMBER(9,0)
2	D2_FUNCTION	N	VARCHAR2(14)
3	USER_CODE	N	VARCHAR2(7)
4	D2_O_DIST	N	NUMBER(10,2)
5	EXERCISE_NUM	N	NUMBER(9,0)
6	D2_O_SLICE_TOTAL_DOSE	Y	NUMBER(10,4)
7	D2_O_SLICE_TIME_TIP	Y	NUMBER(8,2)
8	D2_O_SLICE_TIME_TAIL	Y	NUMBER(8,2)
9	XMIT_INIT_DATE	Y	DATE 7

Table Name
D2_O_SLICE_DOSE_TIME

This table contains D2 output results.

Sequence	Name	N	Format
1	D2_CASE_ID	N	NUMBER(9,0)
2	D2_FUNCTION	N	VARCHAR2(14)
3	USER_CODE	N	VARCHAR2(7)
4	D2_O_DIST	N	NUMBER(10,2)
5	D2_DOSAGE_NUM	N	NUMBER(2,0)
6	EXERCISE_NUM	N	NUMBER(9,0)
7	D2_O_SLICE_DOSE_PCT	Y	NUMBER(5,2)
8	D2_O_SLICE_TIME	Y	NUMBER(10,4)
9	XMIT_INIT_DATE	Y	DATE 7

Table Name
D2_USER_TIME

This table contains D2 control parameters.

Sequence	Name	N	Format
1	D2_CASE_ID	N	NUMBER(9,0)
2	USER_CODE	N	VARCHAR2(7)
3	EXERCISE_NUM	N	NUMBER(9,0)
4	D2_TIME_STEP_INCREMENT	Y	NUMBER(3,0)

Table Name

DATA_ACK

This table contains DAI control parameters.

Sequence	Name	N Format
1	DATA_ACK_ID	N NUMBER(9,0)
2	DATA_TYPE	N VARCHAR2(9)
3	EOC_CODE	N VARCHAR2(4)
4	INSTANCE_NAME	N VARCHAR2(4)
5	SITE_NAME	N VARCHAR2(30)
6	ORACLE_TAB_NAME	N VARCHAR2(30)
7	ORACLE_ROWID	N ROWID 6
8	SAME_SERVER	N CHAR(1)
9	EXERCISE_NUM	N NUMBER(9,0)
10	ACK_ATTEMPTS	Y NUMBER(2,0)
11	ACKNOWLEDGED	Y CHAR(1)
12	EMIS_NUM	Y NUMBER(8,0)
13	DESCRIPTION	Y VARCHAR2(2000)
14	ACK_START_DATE	Y DATE 7
15	ACK_END_DATE	Y DATE 7
16	GMT_MINUTE_OFF	Y NUMBER(4,0)

Table Name

DCDI_UPDATE_STATUS

Sequence	Name	N Format
1	GROUP_INDEX	N NUMBER(3,0)
2	GROUP_NAME	Y VARCHAR2(10)
3	TABLE_NAME	Y VARCHAR2(30)
4	UPDATE_TIME	Y DATE 7
5	DELTA_TIME	Y NUMBER(3,0)
6	DEFER_FLAG	Y VARCHAR2(1)

Table Name

DEPARTMENT

The Department table names the departments in agencies that are concerned with the FEMIS mission.

Sequence	Name	N Format
1	DEPT_CODE	N NUMBER(9,0)
2	EXERCISE_NUM	N NUMBER(9,0)
3	DEPT_NAME	Y VARCHAR2(30)
4	DEPT_ACRONYM	Y VARCHAR2(20)
5	STATE_CODE	Y VARCHAR2(2)
6	CITY_NAME	Y VARCHAR2(20)
7	STREET_ADDRESS1	Y VARCHAR2(40)
8	STREET_ADDRESS2	Y VARCHAR2(40)
9	ZIP_CODE	Y VARCHAR2(10)
10	MAIN_PHONE	Y VARCHAR2(30)
11	FAX_PHONE	Y VARCHAR2(30)
12	CEL_PHONE	Y VARCHAR2(30)
13	BEEPER_PHONE	Y VARCHAR2(30)

14	EMAIL_ADDRESS	Y VARCHAR2 (80)
15	EMAIL_ADDRESS2	Y VARCHAR2 (80)
16	WEB_ADDRESS	Y VARCHAR2 (255)
17	EOC_NAME	Y VARCHAR2 (30)
18	AGENCY_CODE	N NUMBER (9,0)
19	XMIT_INIT_DATE	Y DATE 7

Table Name
DEPENDENCE

The Dependence table shows the plan detail task(s) that must be finished before the indicated task is done.

Sequence	Name	N Format
1	PLAN_REF_ID	N NUMBER (9,0)
2	EXERCISE_NUM	N NUMBER (9,0)
3	PD_UNIQUE_REF_NUM	N NUMBER (7,0)
4	PRED_PLAN_REF_ID	N NUMBER (9,0)
5	PRED_PD_UNIQUE_REF_NUM	N NUMBER (7,0)
6	DEPENDENCY_TYPE	Y VARCHAR2 (10)
7	LEAD_LAG_TIME	Y NUMBER (6,2)

Table Name
DOSAGE

The Dosage table is a validation of the dose levels used to run the D2 model.

Sequence	Name	N Format
1	DOSE_LEVEL	N VARCHAR2 (40)
2	DOSE_DESCRIPTION	N VARCHAR2 (127)

Table Name
EMERGENCY_SUPPORT

The Emergency Support table contains valid support functions for use in an electronic plan.

Sequence	Name	N Format
1	EMERGENCY_SUPPORT_FN	N VARCHAR2 (30)
2	EMS_DESCRIPTION	N VARCHAR2 (127)

Table Name
EOC

The EOC table contains information about EOCs at a CSEPP site.

Sequence	Name	N Format
1	EOC_NAME	N VARCHAR2 (30)
2	EOC_CODE	Y VARCHAR2 (4)
3	EOC_TYPE	Y VARCHAR2 (30)
4	EOC_DESCRIPTION	Y VARCHAR2 (127)
5	EOC_RESPONSIBILITY_AREA	Y VARCHAR2 (92)
6	EOC_NUM	Y NUMBER (3,0)
7	EOC_SERVER_NAME	Y VARCHAR2 (30)
8	EOC_PWD	Y VARCHAR2 (10)

9	EOC_NOTIFY_PORT	Y	NUMBER(9,0)
10	EOC_UNIX_PORT	Y	NUMBER(9,0)
11	SITE_NAME	N	VARCHAR2(30)
12	DEI_USED	Y	CHAR(1)
13	INSTANCE_NAME	Y	VARCHAR2(4)

Table Name

EOC_OBJECTIVE

The EOC Objective table contains operational objectives for center.

Sequence	Name	N	Format
1	EOC_NAME	N	VARCHAR2(30)
2	EO_GOAL_TIME	Y	NUMBER(6,2)
3	EO_DESCRIPTION	Y	VARCHAR2(127)
4	EO_NOTIFY_TIME	Y	NUMBER(6,2)
5	EO_DECISION_TIME	Y	NUMBER(6,2)
6	TIME_ZONE_CODE	Y	VARCHAR2(3)
7	DOSE_LEVEL	Y	VARCHAR2(40)
8	DEFAULT_D2_CASE_ID	Y	NUMBER(9,0)
9	D2PC_EVENT_DELTA_MINUTES	Y	NUMBER(5,0)

Table Name

EOC_ZONE

The EOC Zone table contains the mapping of zones to EOCs.

Sequence	Name	N	Format
1	EOC_NAME	N	VARCHAR2(30)
2	ZONE_NAME	N	VARCHAR2(30)
3	POLYGONAL_LAYER_ID	N	NUMBER(9,0)

Table Name

EP_ERROR_CODES

These are the error codes used in the Evac model.

Sequence	Name	N	Format
1	EP_ERROR_CODE	N	NUMBER(5,0)
2	EP_ERROR_DESCRIPTION	Y	VARCHAR2(900)

Table Name

EVACUATION_PLAN

The Evacuation Plan table contains data describing how an evacuation should take place.

Sequence	Name	N	Format
1	EVAC_CASE_ID	N	NUMBER(9,0)
2	EXERCISE_NUM	N	NUMBER(9,0)
3	EVAC_CASE_NUM	Y	NUMBER(9,0)
4	EVAC_DATE_CREATED	Y	DATE 7
5	EVAC_DATE_MODIFIED	Y	DATE 7
6	EVAC_DATE_EXECUTED	Y	DATE 7
7	EVAC_DATE_GRAPHED	Y	DATE 7

8	EV_I_000_1ST_DESC	Y VARCHAR2 (72)
9	EV_I_001_USER_NAME	Y VARCHAR2 (36)
10	EV_I_001_DATE_C	Y DATE 7
11	EV_I_001_AGENCY	Y VARCHAR2 (24)
12	EV_I_001_RUN_NUM	Y NUMBER (4,0)
13	EV_I_002_RUN_TYPE	Y NUMBER (1,0)
14	EV_I_002_FILL_TIME	Y NUMBER (4,0)
15	EV_I_002_PCT_USE	Y NUMBER (3,0)
16	EV_I_002_PCT_CAPACITY	Y NUMBER (3,0)
17	EV_I_002_START_TIME	Y DATE 7
18	EV_I_002_UNITS_IN	Y VARCHAR2 (1)
19	EV_I_002_UNITS_OUT	Y VARCHAR2 (1)
20	EV_I_002_TDIST	Y VARCHAR2 (1)
21	EV_I_004_LEN_INTERVAL	Y NUMBER (4,0)
22	EV_I_004_TIME_SLICES	Y NUMBER (4,0)
23	EV_I_005_NTI_OUT_CUM	Y NUMBER (4,0)
24	EV_I_005_NTI_OUT_INT	Y NUMBER (4,0)
25	EV_I_005_OUTPUT_CODE_S	Y VARCHAR2 (1)
26	EV_I_005_OUTPUT_CODE_P	Y VARCHAR2 (1)
27	EV_I_006_LON	Y NUMBER (13,8)
28	EV_I_006_LAT	Y NUMBER (13,8)
29	EV_1C_NUM_PEOPLE_VEH	Y NUMBER (4,2)
30	EV_1C_ROAD_AGGREGATION	Y VARCHAR2 (30)

Table Name
EVACUATION_SITUATION

Sequence	Name	N Format
1	EVAC_CASE_ID	N NUMBER (9,0)
2	EXERCISE_NUM	N NUMBER (9,0)
3	OTHER_CONDITION	N VARCHAR2 (256)
4	ORGANIZATIONAL_CONDITION	N VARCHAR2 (256)
5	POP_COND_NAME	N VARCHAR2 (30)
6	ROAD_CONDITION	N VARCHAR2 (256)
7	SITUATION_SEASON	N VARCHAR2 (6)
8	SPECIAL_WEATHER	N VARCHAR2 (15)
9	COMMUNITY_CONDITION	N VARCHAR2 (256)
10	HAZARD_TYPE	N VARCHAR2 (15)
11	SITUATION_COMMENT	Y VARCHAR2 (127)

Table Name
EVACUATION_ZONES

Sequence	Name	N Format
1	EVAC_CASE_ID	N NUMBER (9,0)
2	EXERCISE_NUM	N NUMBER (9,0)
3	EV_1C_ZONE_NAME	N VARCHAR2 (30)
4	EV_1C_ZONE_LOCATION	Y VARCHAR2 (92)
5	EV_1C_ZONE_DESCRIPTION	Y VARCHAR2 (127)

Table Name
EV_INQUIRY

Sequence	Name	N	Format
1	EV_TP_REF_NUM	N	NUMBER(9,0)
2	EV_MOD_DATE	N	DATE 7
3	EXERCISE_NUM	N	NUMBER(9,0)
4	INQUIRY_ID	N	NUMBER(9,0)
5	INQ_TK_REF_NUM	Y	NUMBER(9,0)
6	INQ_NAME	Y	VARCHAR2(40)
7	INFO_REQUESTED	Y	VARCHAR2(255)
8	INFO_NOTES	Y	VARCHAR2(2000)
9	INFO_RELEASED_FLAG	Y	VARCHAR2(1)
10	INFO_REQUESTED_DATE	Y	DATE 7
11	REL_PERSON_REF_NUM	Y	NUMBER(9,0)

Table Name
EV_I_000_DESCRIPTION

Sequence	Name	N	Format
1	EVAC_CASE_ID	N	NUMBER(9,0)
2	EV_I_000_SEQ_NUM	N	NUMBER(4,0)
3	EXERCISE_NUM	N	NUMBER(9,0)
4	EV_I_000_DESC	Y	VARCHAR2(72)

Table Name
EV_I_003_TIME_PERIODS

Sequence	Name	N	Format
1	EVAC_CASE_ID	N	NUMBER(9,0)
2	EV_TIME_PERIOD	N	NUMBER(2,0)
3	EXERCISE_NUM	N	NUMBER(9,0)
4	EV_I_003_TP_LEN	Y	NUMBER(4,0)
5	EV_1C_PCT_LOADED	Y	NUMBER(3,0)

Table Name
EV_I_011_LINK_CHANNEL

Sequence	Name	N	Format
1	EVAC_CASE_ID	N	NUMBER(9,0)
2	EV_TIME_PERIOD	N	NUMBER(2,0)
3	EV_LINK_NUM	N	NUMBER(5,0)
4	EXERCISE_NUM	N	NUMBER(9,0)
5	EV_I_011_CHAN_LANE_1	Y	VARCHAR2(1)
6	EV_I_011_CHAN_LANE_2	Y	VARCHAR2(1)
7	EV_I_011_CHAN_LANE_3	Y	VARCHAR2(1)
8	EV_I_011_CHAN_LANE_4	Y	VARCHAR2(1)
9	EV_I_011_CHAN_LANE_5	Y	VARCHAR2(1)
10	EV_I_011_CHAN_LANE_6	Y	VARCHAR2(1)
11	EV_I_011_FREE_FLOW_SPEED	Y	NUMBER(2,0)
12	EV_I_011_MEAN_Q_DISCH_H	Y	NUMBER(4,0)

13	EV_I_011_PED_CODE	Y VARCHAR2(1)
14	EV_I_011_RTOR_CODE	Y VARCHAR2(1)
15	EV_I_011_STARTUP_LOST_TIME	Y NUMBER(3,0)

Table Name
EV_I_011_LINK_DEFINITION

Sequence	Name	N Format
1	EVAC_CASE_ID	N NUMBER(9,0)
2	EV_LINK_NUM	N NUMBER(5,0)
3	EXERCISE_NUM	N NUMBER(9,0)
4	EV_I_011_NN_UP	N NUMBER(4,0)
5	EV_I_011_NN_DOWN	N NUMBER(4,0)
6	EV_I_011_LINK_LEN	Y NUMBER(5,0)
7	EV_I_011_N LANES FULL	Y NUMBER(1,0)
8	EV_I_011_N LANES LTP	Y NUMBER(1,0)
9	EV_I_011_N LANES RTP	Y NUMBER(1,0)
10	EV_I_011_PCT_GRADE	Y NUMBER(3,0)
11	EV_I_011_NN_DOWN_L	Y NUMBER(4,0)
12	EV_I_011_NN_DOWN_T	Y NUMBER(4,0)
13	EV_I_011_NN_DOWN_R	Y NUMBER(4,0)
14	EV_I_011_NN_DOWN_D	Y NUMBER(5,0)
15	EV_I_011_NN_UP_T	Y NUMBER(4,0)
16	ROUTE_NAME	Y VARCHAR2(30)
17	ROUTE_SEG_NUM	Y NUMBER(6,0)

Table Name
EV_I_015_LINK_DEF_FREEMWAY

Sequence	Name	N Format
1	EVAC_CASE_ID	N NUMBER(9,0)
2	EV_LINK_NUM_F	N NUMBER(5,0)
3	EXERCISE_NUM	N NUMBER(9,0)
4	EV_I_015_NN_UP	N NUMBER(4,0)
5	EV_I_015_NN_DN_THRU_1	Y NUMBER(4,0)
6	EV_I_015_NN_DN_THRU_2	Y NUMBER(4,0)
7	EV_I_015_NN_DN_OFF_R	Y NUMBER(4,0)
8	EV_I_015_NN_DOWN	N NUMBER(4,0)
9	EV_I_015_LINK_LEN	Y NUMBER(4,0)
10	EV_I_015_N REG USE LANES	Y NUMBER(1,0)
11	EV_I_015_NN_UP_ON_R	Y NUMBER(4,0)

Table Name
EV_I_015_LINK_FLOW

Sequence	Name	N Format
1	EVAC_CASE_ID	N NUMBER(9,0)
2	EV_TIME_PERIOD	N NUMBER(2,0)
3	EXERCISE_NUM	N NUMBER(9,0)
4	EV_LINK_NUM_F	N NUMBER(5,0)

5	EV_I_015_SDR	Y NUMBER(1,0)
6	EV_I_015_NOM_CAP_PLH	Y NUMBER(4,0)
7	EV_I_015_FREE_FLOW_SPEED	Y NUMBER(3,0)

Table Name
EV_I_021_TURNS

Sequence	Name	N Format
1	EVAC_CASE_ID	N NUMBER(9,0)
2	EV_TIME_PERIOD	N NUMBER(2,0)
3	EV_LINK_NUM	N NUMBER(5,0)
4	EXERCISE_NUM	N NUMBER(9,0)
5	EV_I_021_PCT_L	Y NUMBER(4,0)
6	EV_I_021_PCT_T	Y NUMBER(4,0)
7	EV_I_021_PCT_R	Y NUMBER(4,0)
8	EV_I_021_PCT_D	Y NUMBER(4,0)
9	EV_I_021_DISCH_PROH_L	Y VARCHAR2(1)
10	EV_I_021_DISCH_PROH_T	Y VARCHAR2(1)
11	EV_I_021_DISCH_PROH_R	Y VARCHAR2(1)
12	EV_I_021_DISCH_PROH_D	Y VARCHAR2(1)
13	EV_I_021_PCT_BLOCK	Y NUMBER(3,0)

Table Name
EV_I_026_TURNS_FREEWAY

Sequence	Name	N Format
1	EVAC_CASE_ID	N NUMBER(9,0)
2	EV_TIME_PERIOD	N NUMBER(2,0)
3	EXERCISE_NUM	N NUMBER(9,0)
4	EV_LINK_NUM_F	N NUMBER(5,0)
5	EV_I_026_NN_DOWN_THRU_1	Y NUMBER(4,0)
6	EV_I_026_PCT_THRU_1	Y NUMBER(3,0)
7	EV_I_026_NN_DOWN_THRU_2	Y NUMBER(4,0)
8	EV_I_026_PCT_THRU_2	Y NUMBER(3,0)
9	EV_I_026_PCT_OFF	Y NUMBER(3,0)
10	EV_I_026_NN_DOWN_OFF	Y NUMBER(4,0)

Table Name
EV_I_034_FREEWAY_SUB_PARM

Sequence	Name	N Format
1	EVAC_CASE_ID	N NUMBER(9,0)
2	EXERCISE_NUM	N NUMBER(9,0)
3	EV_I_034_REL_T_COEF	Y NUMBER(4,0)
4	EV_I_034_ANT_COEF	Y NUMBER(4,0)
5	EV_I_034_MAX_DUR_TS	Y NUMBER(4,0)
6	EV_I_034_1ST_SDR_C_R1	Y NUMBER(4,0)
7	EV_I_034_1ST_SDR_C_R2	Y NUMBER(4,0)
8	EV_I_034_1ST_SDR_C_R3	Y NUMBER(4,0)
9	EV_I_034_2ND_SDR_C_R1	Y NUMBER(4,0)
10	EV_I_034_2ND_SDR_C_R2	Y NUMBER(4,0)
11	EV_I_034_2ND_SDR_C_R3	Y NUMBER(4,0)

12	EV_I_034_3RD_SDR_C_R1	Y NUMBER(4,0)
13	EV_I_034_3RD_SDR_C_R2	Y NUMBER(4,0)
14	EV_I_034_3RD_SDR_C_R3	Y NUMBER(4,0)
15	EV_I_034_4TH_SDR_C_R1	Y NUMBER(4,0)
16	EV_I_034_4TH_SDR_C_R2	Y NUMBER(4,0)
17	EV_I_034_4TH_SDR_C_R3	Y NUMBER(4,0)
18	EV_I_034_5TH_SDR_C_R3	Y NUMBER(4,0)
19	EV_I_034_JAM_DEN	Y NUMBER(4,0)

Table Name
EV_I_035_036_SIGNAL

Sequence	Name	N Format
1	EVAC_CASE_ID	N NUMBER(9,0)
2	EV_NODE_NUM	N NUMBER(4,0)
3	EXERCISE_NUM	N NUMBER(9,0)
4	EV_I_035_REF_OFFSET	Y NUMBER(4,0)
5	EV_I_035_NN_UP_1	Y NUMBER(4,0)
6	EV_I_035_NN_UP_2	Y NUMBER(4,0)
7	EV_I_035_NN_UP_3	Y NUMBER(4,0)
8	EV_I_035_NN_UP_4	Y NUMBER(4,0)
9	EV_I_035_NN_UP_5	Y NUMBER(4,0)
10	EV_I_035_SIG_INT_1	Y NUMBER(4,0)
11	EV_I_035_SIG_INT_2	Y NUMBER(4,0)
12	EV_I_035_SIG_INT_3	Y NUMBER(4,0)
13	EV_I_035_SIG_INT_4	Y NUMBER(4,0)
14	EV_I_035_SIG_INT_5	Y NUMBER(4,0)
15	EV_I_035_SIG_INT_6	Y NUMBER(4,0)
16	EV_I_035_SIG_INT_7	Y NUMBER(4,0)
17	EV_I_035_SIG_INT_8	Y NUMBER(4,0)
18	EV_I_035_SIG_INT_9	Y NUMBER(4,0)
19	EV_I_036_CONTROL_CODE	Y VARCHAR2(45)

Table Name
EV_I_049_RING

Sequence	Name	N Format
1	EVAC_CASE_ID	N NUMBER(9,0)
2	EV_TIME_PERIOD	N NUMBER(2,0)
3	EXERCISE_NUM	N NUMBER(9,0)
4	EV_I_049_PCT_EVAC_MAN	Y NUMBER(3,0)
5	EV_I_049_PCT_EVAC_VOL	Y NUMBER(3,0)

Table Name
EV_I_049_RING_NUMBER

Sequence	Name	N Format
1	EVAC_CASE_ID	N NUMBER(9,0)
2	EV_TIME_PERIOD	N NUMBER(2,0)
3	EV_I_049_RING_NUMB	N NUMBER(1,0)
4	EXERCISE_NUM	N NUMBER(9,0)
5	EV_I_049_RING_FLAG	Y VARCHAR2(1)

Table Name
EV_I_049_RING_SECTORS

Sequence	Name	N Format
1	EVAC_CASE_ID	N NUMBER(9,0)
2	EV_TIME_PERIOD	N NUMBER(2,0)
3	EV_I_049_RING_NUMB	N NUMBER(1,0)
4	EV_I_049_RSEC_NUMB	N NUMBER(2,0)
5	EXERCISE_NUM	N NUMBER(9,0)
6	EV_I_049_RSEC_FLAG	Y VARCHAR2(1)

Table Name
EV_I_050_ENTRY_LINKS

Sequence	Name	N Format
1	EVAC_CASE_ID	N NUMBER(9,0)
2	EV_TIME_PERIOD	N NUMBER(2,0)
3	EV_LINK_NUM	N NUMBER(5,0)
4	EXERCISE_NUM	N NUMBER(9,0)
5	EV_I_050_VEHICLES_HR	Y NUMBER(4,0)
6	EV_I_050_PCT_TRUCKS	Y NUMBER(3,0)

Table Name
EV_I_051_SOURCE_SINK

Sequence	Name	N Format
1	EVAC_CASE_ID	N NUMBER(9,0)
2	EV_TIME_PERIOD	N NUMBER(2,0)
3	EV_LINK_NUM	N NUMBER(5,0)
4	EV_I_051_SS_CENTROID	N NUMBER(4,0)
5	EXERCISE_NUM	N NUMBER(9,0)
6	EV_I_051_NET_VOLUME	Y NUMBER(4,0)

Table Name
EV_I_052_LOAD_FACTORS

Sequence	Name	N Format
1	EVAC_CASE_ID	N NUMBER(9,0)
2	EV_TIME_PERIOD	N NUMBER(2,0)
3	EXERCISE_NUM	N NUMBER(9,0)
4	EV_I_052_AVG_PER_AUTO	Y NUMBER(4,0)
5	EV_I_052_AVG_PER_POOL	Y NUMBER(4,0)
6	EV_I_052_AVG_PER_TRUCK	Y NUMBER(4,0)
7	EV_I_052_AVG_PER_BUS	Y NUMBER(4,0)

Table Name
EV_I_175_TA_PARMS

Sequence	Name	N	Format
1	EVAC_CASE_ID	N	NUMBER(9,0)
2	EV_TIME_PERIOD	N	NUMBER(2,0)
3	EXERCISE_NUM	N	NUMBER(9,0)
4	EV_I_175_EXP_VAL	Y	NUMBER(4,0)
5	EV_I_175_MAX_INNER_ITER	Y	NUMBER(4,0)
6	EV_I_175_COEFF_A	Y	NUMBER(4,0)
7	EV_I_175_COEFF_B	Y	NUMBER(4,0)
8	EV_I_175_KALMAN_FILTER	Y	NUMBER(4,0)
9	EV_I_175_MAX_OUTER_ITER	Y	NUMBER(4,0)
10	EV_I_175_LS_ACC	Y	NUMBER(4,0)
11	EV_I_175_IMP_CODE	Y	VARCHAR2(1)
12	EV_I_175_OPT_CODE	Y	VARCHAR2(1)
13	EV_I_175_TA_CODE	Y	VARCHAR2(1)
14	EV_I_175_PCT_DISCHARGE	Y	NUMBER(3,0)
15	EV_I_175_PCT_IMP	Y	NUMBER(3,0)

Table Name
EV_I_176_179_DEST

Sequence	Name	N	Format
1	EVAC_CASE_ID	N	NUMBER(9,0)
2	EV_TIME_PERIOD	N	NUMBER(2,0)
3	EV_I_176_179_CNN_S	N	NUMBER(4,0)
4	EV_I_176_179_CNN_D	N	NUMBER(4,0)
5	EXERCISE_NUM	N	NUMBER(9,0)
6	EV_I_176_179_VPH_D	Y	NUMBER(4,0)

Table Name
EV_I_176_179_SOURCE

Sequence	Name	N	Format
1	EVAC_CASE_ID	N	NUMBER(9,0)
2	EV_TIME_PERIOD	N	NUMBER(2,0)
3	EV_I_176_179_CNN_S	N	NUMBER(4,0)
4	EXERCISE_NUM	N	NUMBER(9,0)
5	EV_I_176_179_VPH_S	Y	NUMBER(4,0)

Table Name
EV_I_177_CENTROIDS

Sequence	Name	N	Format
1	EVAC_CASE_ID	N	NUMBER(9,0)
2	EV_TIME_PERIOD	N	NUMBER(2,0)
3	EV_LINK_NUM	N	NUMBER(5,0)
4	EXERCISE_NUM	N	NUMBER(9,0)
5	EV_I_177_CN	Y	NUMBER(4,0)

Table Name
EV_I_178_DEST_ATTRACTORS

Sequence	Name	N	Format
1	EVAC_CASE_ID	N	NUMBER(9,0)
2	EV_TIME_PERIOD	N	NUMBER(2,0)
3	EV_NODE_NUM	N	NUMBER(4,0)
4	EXERCISE_NUM	N	NUMBER(9,0)
5	EV_I_178_VPH_ATTRACTOR	Y	NUMBER(4,0)

Table Name
EV_I_195_CASE_NODE

Sequence	Name	N	Format
1	EVAC_CASE_ID	N	NUMBER(9,0)
2	EV_NODE_NUM	N	NUMBER(4,0)
3	EXERCISE_NUM	N	NUMBER(9,0)
4	EV_NODE_ID	Y	NUMBER(9,0)
5	EV_NODE_DESCRIPTION	Y	VARCHAR2(127)
6	EV_NODE_TYPE	Y	VARCHAR2(1)
7	EV_O_2_ASSOC_NODE_ENTRY	Y	NUMBER(4,0)
8	EV_O_2_ASSOC_NODE_EXIT	Y	NUMBER(4,0)
9	EV_I_XOFFSET	Y	NUMBER(6,0)
10	EV_I_YOFFSET	Y	NUMBER(6,0)

Table Name
EV_I_195_NODE

Sequence	Name	N	Format
1	EV_NODE_ID	N	NUMBER(9,0)
2	EXERCISE_NUM	N	NUMBER(9,0)
3	EV_I_195_NODE_NAME	Y	VARCHAR2(20)
4	EV_I_195_NODE_LON	Y	NUMBER(13,8)
5	EV_I_195_NODE_LAT	Y	NUMBER(13,8)
6	EV_NODE_LONG_DESC	Y	VARCHAR2(127)

Table Name
EV_O_1_LINK_STATISTICS

Sequence	Name	N	Format
1	EVAC_CASE_ID	N	NUMBER(9,0)
2	EV_O_TS	N	NUMBER(3,0)
3	EV_LINK_NUM	N	NUMBER(5,0)
4	EXERCISE_NUM	N	NUMBER(9,0)
5	EV_O_1_VHPCT	Y	NUMBER(3,0)
6	EV_O_1_VHCNT	Y	NUMBER(6,0)
7	EV_O_1_DELVEH	Y	NUMBER(8,0)
8	EV_O_1_AVGSPD	Y	NUMBER(3,1)
9	EV_O_1_VEHT	Y	NUMBER(8,0)
10	EV_O_1_QUEUE	Y	NUMBER(6,0)
11	EV_O_1_AVG_TRAVEL_TIME	Y	NUMBER(8,2)

12	EV_O_1_C_PCTSTOP	Y NUMBER(3,0)
13	EV_O_1_C_MT	Y NUMBER(7,1)
14	EV_O_1_C_PEPDISCHG	Y NUMBER(10,0)
15	EV_O_1_C_VEHMILES	Y NUMBER(10,0)
16	EV_O_1_C_VEHMINUTES	Y NUMBER(10,0)

Table Name
EV_O_3_TIME_PERIOD

Sequence	Name	N Format
1	EVAC_CASE_ID	N NUMBER(9,0)
2	EV_O_3_TP	N NUMBER(2,0)
3	EV_O_3_CN	N NUMBER(4,0)
4	EXERCISE_NUM	N NUMBER(9,0)
5	EV_O_3_LRATE	Y NUMBER(4,0)
6	EV_LINK_NUM	Y NUMBER(5,0)

Table Name
EV_O_4_STEP_LOAD

Sequence	Name	N Format
1	EVAC_CASE_ID	N NUMBER(9,0)
2	EV_O_TS	N NUMBER(3,0)
3	EV_O_4_CNN	N NUMBER(4,0)
4	EXERCISE_NUM	N NUMBER(9,0)
5	EV_O_4_TVL	Y NUMBER(5,0)
6	EV_O_4_TRL	Y NUMBER(5,0)

Table Name
EV_O_5_CASE_SUMMARY

Sequence	Name	N Format
1	EVAC_CASE_ID	N NUMBER(9,0)
2	EXERCISE_NUM	N NUMBER(9,0)
3	EV_O_5_VEHT	Y NUMBER(8,0)
4	EV_O_5_PCTSTOP	Y NUMBER(3,0)
5	EV_O_5_MT	Y NUMBER(7,1)
6	EV_O_5_AVGSPD	Y NUMBER(3,1)
7	EV_O_5_DELVEH	Y NUMBER(8,0)
8	EV_O_5_NOUT	Y NUMBER(3,0)
9	EV_O_5_EVACTIME	Y NUMBER(6,0)
10	EV_O_5_C_PEPDISCHG	Y NUMBER(10,0)
11	EV_O_5_C_VEHMILES	Y NUMBER(10,0)
12	EV_O_5_C_VEHMINUTES	Y NUMBER(10,0)
13	EV_O_5_C_TOTALDELAY	Y NUMBER(10,0)
14	EV_O_5_C_AVGQCONTENT	Y NUMBER(6,1)
15	EV_O_5_PNT_FREQ	Y NUMBER(8,0)
16	EV_O_5_C_AVGTOTQ	Y NUMBER(9,1)
17	EV_O_5_VEH_RON	Y NUMBER(9,4)

Table Name
EV_O_6_TIME_STEP

Sequence	Name	N	Format
1	EVAC_CASE_ID	N	NUMBER(9,0)
2	EV_O_TS	N	NUMBER(3,0)
3	EXERCISE_NUM	N	NUMBER(9,0)
4	EV_O_6_VEHS	Y	NUMBER(8,0)
5	EV_O_6_VEHT	Y	NUMBER(8,0)

Table Name
EV_O_7_ERRORS

Sequence	Name	N	Format
1	EVAC_CASE_ID	N	NUMBER(9,0)
2	EV_O_ERROR_NUM	N	NUMBER(4,0)
3	EXERCISE_NUM	N	NUMBER(9,0)
4	EV_O_7_ERROR_TYPE	Y	VARCHAR2(12)
5	EV_O_7_ERROR_SUBR	Y	VARCHAR2(6)
6	EP_ERROR_CODE	Y	NUMBER(5,0)

Table Name
EV_O_7_ERROR_VALUES

Sequence	Name	N	Format
1	EVAC_CASE_ID	N	NUMBER(9,0)
2	EV_O_ERROR_NUM	N	NUMBER(4,0)
3	EV_O_7_ERROR_PVNUM	N	NUMBER(1,0)
4	EXERCISE_NUM	N	NUMBER(9,0)
5	EV_O_7_ERROR_VALUE	Y	NUMBER(9,0)

Table Name
EV_O_8_ERRORS

Sequence	Name	N	Format
1	EVAC_CASE_ID	N	NUMBER(9,0)
2	EV_O_8_ERROR_NUM	N	NUMBER(4,0)
3	EXERCISE_NUM	N	NUMBER(9,0)
4	EV_O_8_ERROR_DESC	Y	VARCHAR2(2000)

Table Name
EXERCISE_CONTROL

The Exercise Control table is the link between the exercise data and the exercise scenario data.

Sequence	Name	N	Format
1	EXERCISE_NUM	N	NUMBER(9,0)
2	EOC_NAME	N	VARCHAR2(30)
3	EXERCISE_ACTIVE_FLAG	Y	VARCHAR2(1)

4	EXERCISE_END_DATE	Y DATE 7
5	EXERCISE_START_DATE	Y DATE 7
6	EXERCISE_CHANGE_DATE	Y DATE 7
7	EXERCISE_DESCRIPTION	Y VARCHAR2 (127)
8	EXERCISE_LONG_DESCRIPTOR	Y VARCHAR2 (2000)
9	XMIT_INIT_DATE	Y DATE 7

Table Name

FACILITY

The Facility table contains information about a building or structure that may need to be considered for some protective action.

Sequence	Name	N Format
1	FACILITY_NAME	N VARCHAR2 (30)
2	EXERCISE_NUM	N NUMBER (9,0)
3	FACILITY_DESCRIPTION	Y VARCHAR2 (255)
4	FACILITY_CAPACITY	Y NUMBER (5,0)
5	FACILITY_LOCATION	Y VARCHAR2 (92)
6	PRESSURIZED_FLAG	Y VARCHAR2 (1)
7	FACILITY_ADDRESS1	Y VARCHAR2 (40)
8	FACILITY_CITY	Y VARCHAR2 (20)
9	FACILITY_STATE_CODE	Y VARCHAR2 (2)
10	FACILITY_ZIP_CODE	Y VARCHAR2 (10)
11	FACILITY_POC_AGENCY	Y NUMBER (9,0)
12	FACILITY_POC_DEPT	Y NUMBER (9,0)
13	FACILITY_POC_POSITION	Y NUMBER (9,0)
14	FACILITY_POC_PERSON_REF_NUM	Y NUMBER (9,0)
15	FACILITY_POC_PHONE	Y VARCHAR2 (30)
16	FACILITY_SHELTER_CAP_FLAG	Y VARCHAR2 (1)
17	FACILITY_ADDRESS2	Y VARCHAR2 (40)
18	FACILITY_TYPE	N VARCHAR2 (40)
19	MAIN_PHONE	Y VARCHAR2 (30)
20	FAX_PHONE	Y VARCHAR2 (30)
21	CEL_PHONE	Y VARCHAR2 (30)
22	BEEPER_PHONE	Y VARCHAR2 (30)
23	EMAIL_ADDRESS	Y VARCHAR2 (80)
24	EMAIL_ADDRESS2	Y VARCHAR2 (80)
25	WEB_ADDRESS	Y VARCHAR2 (255)
26	MOU_ID	Y NUMBER (9,0)
27	EOC_NAME	N VARCHAR2 (30)
28	ZONE_NAME	Y VARCHAR2 (30)
29	XMIT_INIT_DATE	Y DATE 7

Table Name

FACILITY_TYPE

The Facility table contains the valid list of facility types that may be used.

Sequence	Name	N Format
1	FACILITY_TYPE	N VARCHAR2 (40)
2	FACILITY_TYPE_DESCRIPTION	N VARCHAR2 (127)

Table Name

FEMIS_USER

The FEMIS User table contains information about all users of the system.

Sequence	Name	N	Format
1	USER_CODE	N	VARCHAR2(8)
2	USER_PWD	Y	VARCHAR2(10)
3	ACCOUNT_STATUS	Y	VARCHAR2(30)
4	USER_PREFERENCES	Y	LONG
5	PERSON_REF_NUM	N	NUMBER(9,0)
6	EXERCISE_NUM	N	NUMBER(9,0)

Table Name

GENERIC_TEXT

The GENERIC TEXT table is used by the FEMIS application to store lines of text for multiple uses.

Sequence	Name	N	Format
1	GENERIC_TEXT_ID	N	NUMBER(9,0)
2	GEN_SEQ	N	NUMBER(4,0)
3	EXERCISE_NUM	N	NUMBER(9,0)
4	GEN_TYPE	Y	VARCHAR2(80)
5	GEN_DATE	Y	DATE 7
6	EOC_NAME	Y	VARCHAR2(30)
7	HAZARD_ID	Y	NUMBER(9,0)
8	RICH_TEXT_FLAG	Y	VARCHAR2(1)
9	GEN_RECORD	Y	VARCHAR2(512)
10	XMIT_INIT_DATE	Y	DATE 7

Table Name

GEO_OBJECT

The GEO Object table contains positional information about all objects that can be viewed by the GIS.

Sequence	Name	N	Format
1	FEMIS_OBJECT_TYPE	N	VARCHAR2(8)
2	FEMIS_OBJECT_NAME	N	VARCHAR2(30)
3	EXERCISE_NUM	N	NUMBER(9,0)
4	EOC_NAME	N	VARCHAR2(30)
5	LOCATION_NAME	Y	VARCHAR2(30)
6	FEMIS_POINT_X	Y	NUMBER(20,6)
7	FEMIS_POINT_Y	Y	NUMBER(20,6)
8	PROJECTED_POINT_X	Y	NUMBER(20,6)
9	PROJECTED_POINT_Y	Y	NUMBER(20,6)
10	GIS_LAYER_NAME	N	VARCHAR2(30)
11	GIS_OBJECT_ID	N	NUMBER(9,0)
12	FEMIS_OBJECT_SUBTYPE	Y	VARCHAR2(40)
13	LOCATION_TYPE	Y	VARCHAR2(8)
14	EXERCISE_FLAG	Y	VARCHAR2(1)
15	XMIT_INIT_DATE	Y	DATE 7

Table Name

GEO_OBJECT_ZONE

The GEO OBJECT_ZONE table associates objects in the GEO OBJECT table with zones from the ZONE table

Sequence	Name	N Format
1	FEMIS_OBJECT_TYPE	N VARCHAR2 (8)
2	FEMIS_OBJECT_NAME	N VARCHAR2 (30)
3	EXERCISE_NUM	N NUMBER (9,0)
4	ZONE_NAME	N VARCHAR2 (30)
5	POLYGONAL_LAYER_ID	N NUMBER (9,0)
6	EOC_NAME	N VARCHAR2 (30)

Table Name

GIS_LAYER

This table defines the GIS layers or themes available.

Sequence	Name	N Format
1	GIS_LAYER_NAME	N VARCHAR2 (30)
2	EXERCISE_NUM	N NUMBER (9,0)
3	GIS_LAYER_MODIFICATION_DATE	Y DATE 7
4	GIS_LEGEND_NAME	Y VARCHAR2 (32)
5	GIS_LAYER_TYPE	Y VARCHAR2 (10)
6	GIS_LAYER_DESCRIPTION	Y VARCHAR2 (127)
7	GIS_LAYER_SYMBOL_ID	Y NUMBER (3,0)
8	GIS_LAYER_TEXT_FONT	Y NUMBER (3,0)
9	GIS_LAYER_TEXT_COLOR	Y NUMBER (3,0)
10	GIS_LAYER_TEXT_ROTATION	Y NUMBER (3,0)
11	GIS_LAYER_TEXT_SIZE	Y NUMBER (3,0)
12	GIS_LAYER_TEXT_JUSTIFY	Y VARCHAR2 (2)
13	GIS_LAYER_SYMBOL_COLOR	Y NUMBER (3,0)
14	GIS_LAYER_SYMBOL_SIZE	Y NUMBER (3,0)
15	GIS_LAYER_BACK_COLOR	Y NUMBER (3,0)
16	GIS_LAYER_FORE_COLOR	Y NUMBER (3,0)
17	GENERIC_GIS_LAYER_CODE	Y VARCHAR2 (2)
18	SOURCE	Y VARCHAR2 (127)
19	ORIGINAL_MAP_SCALE	Y NUMBER (9,0)
20	ORIGINAL_MAP_PROJECTION	Y VARCHAR2 (127)
21	ACCURACY	Y VARCHAR2 (127)
22	LEGEND_ORDER	Y NUMBER (9,2)
23	LABEL_FIELD	Y VARCHAR2 (20)
24	OBJ_LOOKUP_CATEGORY	Y VARCHAR2 (20)
25	CLASSIFICATION_FIELD	Y VARCHAR2 (20)
26	DEFAULT_LEGEND_TYPE	Y VARCHAR2 (8)
27	MINIMUM_SCALE	Y NUMBER (9,0)
28	MAXIMUM_SCALE	Y NUMBER (9,0)
29	GIS_LAYER_FILE_PATH	Y VARCHAR2 (32)
30	PROCESSING_DETAILS	Y VARCHAR2 (2000)
31	HAZARD_ZONE_LAYER_FLAG	Y VARCHAR2 (1)
32	LOAD_FLAG	Y VARCHAR2 (1)
33	VISIBLE_FLAG	Y VARCHAR2 (1)

34	XMIT_INIT_DATE	Y DATE 7
35	DYNAMIC_LAYER_FLAG	Y VARCHAR2(1)
36	EOC_NAME	Y VARCHAR2(30)

Table Name

GIS_LAYER_DEFINITION

This table contains parameters that control a GIS layer presentation.

Sequence	Name	N Format
1	GENERIC_GIS_LAYER_CODE	N VARCHAR2(2)
2	GENERIC_LAYER_DESCRIPTION	Y VARCHAR2(40)
3	USER_MODIFY_FLAG	Y VARCHAR2(1)
4	FEMIS_OBJECT_FLAG	Y VARCHAR2(1)
5	LAYER_BASE_NAME	Y VARCHAR2(8)
6	LAYER_NAME_SUBST_FLAG	Y VARCHAR2(1)
7	LAYER_SUBST_SOURCE1	Y VARCHAR2(12)
8	LAYER_SUBST_SOURCE2	Y VARCHAR2(12)
9	DEFAULT_LEGEND_BASE_NAME	Y VARCHAR2(16)
10	LEGEND_NAME_SUBST_FLAG	Y VARCHAR2(1)
11	LEGEND_SUBST_SOURCE1	Y VARCHAR2(12)
12	LEGEND_SUBST_SOURCE2	Y VARCHAR2(12)
13	DIRECTORY_BASE_NAME	Y VARCHAR2(8)
14	DIRECTORY_NAME_SUBST_FLAG	Y VARCHAR2(1)
15	DIRECTORY_SUBST_SOURCE	Y VARCHAR2(12)
16	FILE_BASE_NAME	Y VARCHAR2(8)
17	FILE_TYPE	Y VARCHAR2(10)
18	FILE_NAME_SUBST_FLAG	Y VARCHAR2(1)
19	FILE_SUBST_SOURCE1	Y VARCHAR2(12)
20	FILE_SUBST_SOURCE2	Y VARCHAR2(12)

Table Name

GIS_SYMBOL

This table is used to define symbol parameters that may be used by the GIS.

Sequence	Name	N Format
1	GIS_SYMBOL_ID	N NUMBER(9,0)
2	SYMBOL_DESCRIPTION	Y VARCHAR2(127)

Table Name

GIS_THEME_DATA

This table is used to store information about a given GIS theme.

Sequence	Name	N Format
1	GIS_LAYER_NAME	N VARCHAR2(30)
2	EXERCISE_NUM	N NUMBER(9,0)
3	GIS_THEME_DATA_SEQ	N NUMBER(9,0)
4	GIS_THEME_DATA	Y VARCHAR2(2000)
5	XMIT_INIT_DATE	Y DATE 7

Table Name

GOAL

The Goal table is used to validate CSEPP goals.

Sequence	Name	N	Format
1	PLANNING_GOAL	N	VARCHAR2(40)
2	PLAN_GOAL_DESCRIPTION	Y	VARCHAR2(128)

Table Name

G_DEF_COMMUNITY

Sequence	Name	N	Format
1	HAZARD_ID	N	NUMBER(9,0)
2	COMMUNITY_DEF_ID	N	NUMBER(9,0)
3	COMMUNITY_DEF_SEQ	N	NUMBER(2,0)
4	COMMUNITY_LABEL_TYPE	Y	VARCHAR2(5)
5	COMMUNITY_LABEL_DEF	Y	VARCHAR2(20)
6	COMMUNITY_DEF_FIELDS	Y	VARCHAR2(32)
7	COMMUNITY_DEF_WEIGHT	Y	NUMBER(5,2)
8	XMIT_INIT_DATE	Y	DATE 7

Table Name

G_DEF_COMMUNITY_VAL

Sequence	Name	N	Format
1	HAZARD_ID	N	NUMBER(9,0)
2	COMMUNITY_DEF_ID	N	NUMBER(9,0)
3	COMMUNITY_DEF_SEQ	N	NUMBER(2,0)
4	COMMUNITY_VALUE	N	VARCHAR2(20)
5	XMIT_INIT_DATE	Y	DATE 7

Table Name

G_DEF_EMERGENCY

Sequence	Name	N	Format
1	HAZARD_ID	N	NUMBER(9,0)
2	EMER_NAME	Y	VARCHAR2(20)
3	EMER_DESC	Y	VARCHAR2(2000)
4	EMER_NOTIF_SCOPE	Y	VARCHAR2(40)
5	EMER_NOTIF_ALL_EOC	Y	VARCHAR2(1)
6	EMER_NOTIF_ALL_HAZ	Y	VARCHAR2(1)
7	EMER_STATUS_BOARD	Y	VARCHAR2(30)
8	EMER_TIME1_LABEL	Y	VARCHAR2(30)
9	EMER_TIME2_LABEL	Y	VARCHAR2(30)
10	XMIT_INIT_DATE	Y	DATE 7

Table Name
G_DEF_EMERGENCY_LEVELS

Sequence	Name	N	Format
1	HAZARD_ID	N	NUMBER(9,0)
2	HAZ_LEVEL_NAME	N	VARCHAR2(30)
3	HAZ_LEVEL_DESC	Y	VARCHAR2(256)
4	XMIT_INIT_DATE	Y	DATE 7

Table Name
G_DEF_HAZARD_CLASS

Sequence	Name	N	Format
1	HAZARD_ID	N	NUMBER(9,0)
2	HAZARD_NAME	Y	VARCHAR2(20)
3	HAZARD_DESC	Y	VARCHAR2(2000)
4	HAZARD_POLY_MAP	Y	VARCHAR2(30)
5	XMIT_INIT_DATE	Y	DATE 7

Table Name
G_DEF_NAV_BUTTON

Sequence	Name	N	Format
1	HAZARD_ID	N	NUMBER(9,0)
2	BUTTON_INDEX	N	NUMBER(2,0)
3	BUTTON_DEFINED	Y	VARCHAR2(1)
4	LABEL_NAME	Y	VARCHAR2(15)
5	AVAIL_IN_OPS	Y	VARCHAR2(1)
6	AVAIL_IN_PLAN	Y	VARCHAR2(1)
7	AVAIL_ON_NAV	Y	VARCHAR2(1)
8	AVAIL_ON_MENU	Y	VARCHAR2(1)
9	EXE_NAME	Y	VARCHAR2(200)
10	FUNCTION_ID	Y	VARCHAR2(50)
11	INPUT_FORMAT	Y	VARCHAR2(50)
12	OUTPUT_FORMAT	Y	VARCHAR2(50)
13	MAP_AVAILABLE	Y	VARCHAR2(1)
14	MAP_FUNCTION	Y	VARCHAR2(50)
15	AUTOCALC_AVAILABLE	Y	VARCHAR2(1)
16	AUTOCALC_FUNCTION	Y	VARCHAR2(50)
17	XMIT_INIT_DATE	Y	DATE 7

Table Name
G_DEF_NAV_FUNCTION

Sequence	Name	N	Format
1	FUNCTION_ID	N	NUMBER(9,0)
2	VALID_NAV_INDEX	Y	VARCHAR2(20)
3	FUNCTION_NAME	Y	VARCHAR2(50)
4	FUNCTION_DESC	Y	VARCHAR2(50)
5	FUNCTION_TYPE	Y	VARCHAR2(50)
6	XMIT_INIT_DATE	Y	DATE 7

Table Name
G_DEF_NAV_FUNCTION_IO

Sequence	Name	N	Format
1	FUNCTION_ID	N	NUMBER(9,0)
2	DATA_FORMAT_NAME	N	VARCHAR2(50)
3	DATA_FORMAT_DESC	Y	VARCHAR2(50)
4	DATA_FORMAT_TYPE	Y	VARCHAR2(6)
5	XMIT_INIT_DATE	Y	DATE 7

Table Name
G_DEF_PAD_LABELS

Sequence	Name	N	Format
1	HAZARD_ID	N	NUMBER(9,0)
2	PAD_LABEL_INDEX	N	NUMBER(2,0)
3	PAD_LABEL_TEXT	Y	VARCHAR2(127)
4	XMIT_INIT_DATE	Y	DATE 7

Table Name
G_EMERGENCY

Sequence	Name	N	Format
1	EOC_NAME	N	VARCHAR2(30)
2	HAZARD_ID	N	NUMBER(9,0)
3	EXERCISE_NUM	N	NUMBER(9,0)
4	EMERGENCY_ID	N	NUMBER(9,0)
5	EMER_MOD_DATE	N	DATE 7
6	EMER_NAME	Y	VARCHAR2(30)
7	EMER_DESC	Y	VARCHAR2(2000)
8	EMER_PERSON_DECLARED	Y	VARCHAR2(40)
9	EMER_USER_CODE	Y	VARCHAR2(8)
10	EMER_DATE_CLOSED	Y	DATE 7
11	EMER_IN_PROG_FLAG	Y	VARCHAR2(1)
12	EMER_CURRENT_RECORD	Y	VARCHAR2(1)
13	EMER_NOTIF_ALL_EOC	Y	VARCHAR2(1)
14	EMER_NOTIF_ALL_HAZ	Y	VARCHAR2(1)
15	HAZ_LEVEL_NAME	Y	VARCHAR2(30)
16	EMER_TIME1	Y	DATE 7
17	EMER_TIME2	Y	DATE 7
18	XMIT_INIT_DATE	Y	DATE 7

Table Name
G_NAVIGATOR_ITEM

Sequence	Name	N	Format
1	SITE_NAME	N	VARCHAR2(30)
2	EOC_NAME	N	VARCHAR2(30)
3	HAZARD_ID	N	NUMBER(9,0)
4	EXERCISE_NUM	N	NUMBER(9,0)
5	MODE_NAME	N	VARCHAR2(10)

6	CURRENT_DATASET_NAME	N VARCHAR2 (20)
7	LC_USER_CODE	N VARCHAR2 (8)
8	ITEM_INDEX	N NUMBER (2,0)
9	CURRENT_ID	Y VARCHAR2 (2000)
10	SUPPLEMENTAL_ID	Y VARCHAR2 (2000)
11	CURRENT_DATE	Y DATE 7
12	CURRENT_USER	Y VARCHAR2 (8)
13	ITEM_SHORT_DESC	Y VARCHAR2 (50)
14	ITEM_LONG_DESC	Y VARCHAR2 (2000)
15	XMIT_INIT_DATE	Y DATE 7

Table Name

HAZARD_SITE

The Hazard Site table describes common hazards that are possible at the emergency operations site.

Sequence	Name	N Format
1	SITE_NAME	N VARCHAR2 (30)
2	SITE_TYPE	N VARCHAR2 (20)
3	MODEL_SITE_CODE	Y VARCHAR2 (30)
4	SITE_DESCRIPTION	Y VARCHAR2 (127)

Table Name

INTERVAL_QUANTITY

Sequence	Name	N Format
1	LOCAL_ID_CODE	N VARCHAR2 (20)
2	EXERCISE_NUM	N NUMBER (9,0)
3	RELEASE_NUM	N NUMBER (2,0)
4	IQ_INTERVAL_NUM	N NUMBER (2,0)
5	QUANTITY_PER_INTERVAL	Y NUMBER (13,2)
6	IQ_TIME_MINUTES	Y NUMBER (6,2)
7	XMIT_INIT_DATE	Y DATE 7
8	QUANTITY_PER_INTERVAL_SRC	Y CHAR (1)

Table Name

JOURNAL

The Journal table is used to save significant events that occurred while the FEMIS system was in operation.

Sequence	Name	N Format
1	JOURNAL_REC_ID	N NUMBER (9,0)
2	EOC_NAME	N VARCHAR2 (30)
3	EXERCISE_NUM	N NUMBER (9,0)
4	JOURNAL_ENTERED_DATE	N DATE 7
5	JOURNAL_CATEGORY	N VARCHAR2 (15)
6	JOURNAL_ACTUAL_TIME	Y DATE 7
7	JOURNAL_SUBJECT	Y VARCHAR2 (30)
8	JOURNAL_INFORMATION	Y VARCHAR2 (2000)
9	JOURNAL_MANUAL_ENTRY_FLAG	Y VARCHAR2 (1)
10	JOURNAL_ATTR_FLAGS	Y VARCHAR2 (10)
11	JOURNAL_USER_NAME	Y VARCHAR2 (40)

12	JOURNAL_USER_CODE	Y VARCHAR2(8)
13	XMIT_INIT_DATE	Y DATE 7
14	HAZARD_ID	Y NUMBER(9,0)

Table Name
KNOWN_POINT

A control table that describes an area defined by a point on a map.

Sequence	Name	N Format
1	KP_REF_ID	N NUMBER(9,0)
2	EXERCISE_NUM	N NUMBER(9,0)
3	KP_NAME	N VARCHAR2(30)
4	KP_SUB_CLASS_REF_ID	N NUMBER(9,0)
5	KP_DESCRIPTION	Y VARCHAR2(255)
6	EOC_NAME	N VARCHAR2(30)
7	ZONE_NAME	Y VARCHAR2(30)
8	POC	Y VARCHAR2(255)
9	STATUS_1	Y VARCHAR2(32)
10	STATUS_2	Y VARCHAR2(32)
11	STATUS_3	Y VARCHAR2(32)
12	STATUS_4	Y VARCHAR2(32)
13	STATUS_5	Y VARCHAR2(32)
14	NOTES	Y VARCHAR2(2000)
15	LAST_CHANGE_DATE	N DATE 7
16	LAST_CHANGE_PERSON	N VARCHAR2(40)
17	XMIT_INIT_DATE	Y DATE 7

Table Name
KNOWN_POLYGON

A control table that describes an area defined by a polygon on a map.

Sequence	Name	N Format
1	KPOLY_REF_ID	N NUMBER(9,0)
2	EXERCISE_NUM	N NUMBER(9,0)
3	KPOLY_NAME	N VARCHAR2(30)
4	KP_SUB_CLASS_REF_ID	N NUMBER(9,0)
5	KPOLY_DESCRIPTION	Y VARCHAR2(255)
6	EOC_NAME	N VARCHAR2(30)
7	POC	Y VARCHAR2(255)
8	STATUS_1	Y VARCHAR2(32)
9	STATUS_2	Y VARCHAR2(32)
10	STATUS_3	Y VARCHAR2(32)
11	STATUS_4	Y VARCHAR2(32)
12	STATUS_5	Y VARCHAR2(32)
13	NOTES	Y VARCHAR2(2000)
14	LAST_CHANGE_DATE	N DATE 7
15	LAST_CHANGE_PERSON	N VARCHAR2(40)
16	XMIT_INIT_DATE	Y DATE 7

Table Name
KP_CLASS_DEF

Sequence	Name	N	Format
1	KP_CLASS_REF_ID	N	NUMBER(9,0)
2	EXERCISE_NUM	N	NUMBER(9,0)
3	FEATURE_TYPE	N	VARCHAR2(30)
4	EOC_NAME	N	VARCHAR2(30)
5	KP_CLASS_NAME	N	VARCHAR2(8)
6	CLASS_DESCRIPTION	Y	VARCHAR2(255)
7	CLASS_NOTES	Y	VARCHAR2(2000)
8	GIS_LAYER_NAME	Y	VARCHAR2(30)
9	EDIT_FLAG	Y	CHAR(1)
10	STATUS_1_TYPE	Y	VARCHAR2(32)
11	STATUS_1_LABEL	Y	VARCHAR2(16)
12	STATUS_2_TYPE	Y	VARCHAR2(32)
13	STATUS_2_LABEL	Y	VARCHAR2(16)
14	STATUS_3_TYPE	Y	VARCHAR2(32)
15	STATUS_3_LABEL	Y	VARCHAR2(16)
16	STATUS_4_TYPE	Y	VARCHAR2(32)
17	STATUS_4_LABEL	Y	VARCHAR2(16)
18	STATUS_5_TYPE	Y	VARCHAR2(32)
19	STATUS_5_LABEL	Y	VARCHAR2(16)
20	DEFAULT_POC	Y	VARCHAR2(255)
21	LAST_CHANGE_DATE	N	DATE 7
22	LAST_CHANGE_PERSON	N	VARCHAR2(40)
23	XMIT_INIT_DATE	Y	DATE 7

Table Name
KP_SUB_CLASS_DEF

Sequence	Name	N	Format
1	KP_SUB_CLASS_REF_ID	N	NUMBER(9,0)
2	EXERCISE_NUM	N	NUMBER(9,0)
3	EOC_NAME	N	VARCHAR2(30)
4	KP_SUB_CLASS_NAME	N	VARCHAR2(40)
5	GIS_LAYER_NAME	Y	VARCHAR2(30)
6	KP_CLASS_REF_ID	N	NUMBER(9,0)
7	SUB_CLASS_DESCRIPTION	Y	VARCHAR2(255)
8	EDIT_FLAG	Y	CHAR(1)
9	LAST_CHANGE_DATE	N	DATE 7
10	LAST_CHANGE_PERSON	N	VARCHAR2(40)
11	XMIT_INIT_DATE	Y	DATE 7

Table Name
LOCAL_CONFIG

The Local Configuration table contains information about the current state of the system.

Sequence	Name	N	Format
1	SITE_NAME	N	VARCHAR2(30)
2	EOC_NAME	N	VARCHAR2(30)

3	EXERCISE_NUM	N	NUMBER(9,0)
4	MODE_NAME	N	VARCHAR2(10)
5	CURRENT_DATASET_NAME	N	VARCHAR2(20)
6	LC_USER_CODE	N	VARCHAR2(8)
7	CURRENT_D2_CASE_ID	Y	NUMBER(9,0)
8	CURRENT_MET_ID	Y	NUMBER(9,0)
9	CURRENT_WORK_PLAN_ID	Y	NUMBER(9,0)
10	CURRENT_PLUME_NUM	Y	NUMBER(9,0)
11	CURRENT_PAD_ID	Y	NUMBER(9,0)
12	CURRENT_PLAN_REF_ID	Y	NUMBER(9,0)
13	CURRENT_PLAN_NAME	Y	VARCHAR2(64)
14	CURRENT_EVENT_COUNT	Y	NUMBER(2,0)
15	CURRENT_WEDGE_PG_ID	Y	NUMBER(9,0)
16	CURRENT_THREAT_ID	Y	NUMBER(9,0)
17	CURRENT_SS_ID	Y	NUMBER(9,0)
18	CURRENT_SITUATION_COMMENT	Y	VARCHAR2(127)
19	CURRENT_POP_COND_NAME	Y	VARCHAR2(30)
20	CURRENT_PAR_ID	Y	NUMBER(9,0)
21	CURRENT_ZONE_RISK_GROUP_NAME	Y	VARCHAR2(30)
22	CURRENT_EVAC_CASE_ID	Y	NUMBER(9,0)
23	CURRENT_RESOURCE_COLLECTION	Y	VARCHAR2(20)
24	CURRENT_D2_CASE_DATE	Y	DATE 7
25	CURRENT_MET_DATE	Y	DATE 7
26	CURRENT_WORK_PLAN_DATE	Y	DATE 7
27	CURRENT_PLUME_DATE	Y	DATE 7
28	CURRENT_PAD_DATE	Y	DATE 7
29	CURRENT_PLAN_DATE	Y	DATE 7
30	CURRENT_EVENT_DATE	Y	DATE 7
31	CURRENT_WEDGE_DATE	Y	DATE 7
32	CURRENT_THREAT_DATE	Y	DATE 7
33	CURRENT_SS_DATE	Y	DATE 7
34	CURRENT_POP_COND_DATE	Y	DATE 7
35	CURRENT_DATASET_DATE	Y	DATE 7
36	LC_USER_CODE_DATE	Y	DATE 7
37	CURRENT_PAR_DATE	Y	DATE 7
38	CURRENT_ZONE_RISK_GROUP_DATE	Y	DATE 7
39	CURRENT_EVAC_CASE_DATE	Y	DATE 7
40	CURRENT_RESOURCE_DATE	Y	DATE 7
41	XMIT_INIT_DATE	Y	DATE 7
42	CURRENT_WORK_PLAN_USER	Y	VARCHAR2(8)
43	CURRENT_D2_CASE_USER	Y	VARCHAR2(8)
44	CURRENT_THREAT_USER	Y	VARCHAR2(8)
45	CURRENT_ZONE_RISK_GROUP_USER	Y	VARCHAR2(8)
46	CURRENT_SS_USER	Y	VARCHAR2(8)
47	CURRENT_PAR_USER	Y	VARCHAR2(8)
48	CURRENT_PAD_USER	Y	VARCHAR2(8)
49	CURRENT_PLAN_REF_USER	Y	VARCHAR2(8)
50	CURRENT_EVAC_CASE_USER	Y	VARCHAR2(8)
51	CURRENT_EVAC_NAME	Y	VARCHAR2(80)
52	SENT_OFFPOST_DATE	Y	DATE 7
53	SENT_OFFPOST_USER	Y	VARCHAR2(8)

Table Name

LOCATION_TYPE

The Location Type table describes the kinds of objects that can be displayed in the GIS.

Sequence	Name	N Format
1	LOCATION_TYPE	N VARCHAR2(8)
2	LOC_TYPE_DESCRIPTION	Y VARCHAR2(127)

Table Name

MEASUREMENT_DEFN

The Measurement Definition table describes the valid units of measurements.

Sequence	Name	N Format
1	MEASUREMENT_CLASS	N VARCHAR2(10)

Table Name

MEASUREMENT_TYPE

The Measurement Type table describes the valid classes of measurements.

Sequence	Name	N Format
1	MEASUREMENT_CLASS	N VARCHAR2(10)
2	MEASUREMENT_TYPE	N VARCHAR2(10)
3	MEASUREMENT_DESCRIPTION	Y VARCHAR2(127)

Table Name

MEMO_UNDERSTANDING

The Memo of Understanding table documents an agreement to supply resources, services, etc.

Sequence	Name	N Format
1	MOU_ID	N NUMBER(9,0)
2	EXERCISE_NUM	N NUMBER(9,0)
3	EOC_NAME	Y VARCHAR2(30)
4	MOU_CHANGE_DATE	Y DATE 7
5	MOU_REFERENCE	Y VARCHAR2(10)
6	MOU_DESCRIPTION	Y VARCHAR2(255)
7	MOU_START_DATE	Y DATE 7
8	MOU_EXPIRE_DATE	Y DATE 7
9	MOU_POC_AGENCY	Y NUMBER(9,0)
10	MOU_POC_DEPT	Y NUMBER(9,0)
11	MOU_POC_POSITION	Y NUMBER(9,0)
12	MOU_PERSON_REF_NUM	Y NUMBER(9,0)
13	XMIT_INIT_DATE	Y DATE 7

Table Name

METHOD

The Method table contains the valid list of methods for FEMIS operations.

Sequence	Name	N	Format
1	METHOD_TYPE	N	VARCHAR2(20)
2	METHOD_DESCRIPTION	Y	VARCHAR2(127)

Table Name

MET_CLUSTER

The Met Cluster table has the parameters about the sensor clusters on the towers.

Sequence	Name	N	Format
1	TOWER_NAME	N	VARCHAR2(30)
2	CLUSTER_NUM	N	NUMBER(2,0)
3	CLUSTER_HEIGHT	Y	NUMBER(5,0)
4	XMIT_INIT_DATE	Y	DATE 7

Table Name

MET_CONDITION

The Met Condition table has the current weather parameters from towers in operation.

Sequence	Name	N	Format
1	TOWER_NAME	N	VARCHAR2(30)
2	WX_TIME_VALID	N	DATE 7
3	EXERCISE_NUM	N	NUMBER(9,0)
4	CLUSTER_NUM	N	NUMBER(2,0)
5	WIND_SPEED	Y	NUMBER(5,2)
6	WIND_DIR	Y	NUMBER(3,0)
7	MIXING_HEIGHT	Y	NUMBER(5,0)
8	STABILITY	Y	VARCHAR2(1)
9	TEMPERATURE	Y	NUMBER(5,1)
10	PRESSURE	Y	NUMBER(6,2)
11	HUMIDITY	Y	NUMBER(4,1)
12	CLOUD_HEIGHT	Y	NUMBER(5,0)
13	CURRENT_FLAG	Y	VARCHAR2(1)
14	CLOUD_COVER	Y	NUMBER(2,0)
15	SOLAR_RAD	Y	NUMBER(7,1)
16	XMIT_INIT_DATE	Y	DATE 7
17	WIND_SIGMA	Y	NUMBER(9,2)

Table Name

MET_CONDITION_OLD

Sequence	Name	N	Format
1	TOWER_NAME	N	VARCHAR2(30)
2	WX_TIME_VALID	N	DATE 7
3	EXERCISE_NUM	N	NUMBER(9,0)
4	CLUSTER_NUM	N	NUMBER(2,0)

5	WIND_SPEED	Y NUMBER(5,2)
6	WIND_DIR	Y NUMBER(3,0)
7	MIXING_HEIGHT	Y NUMBER(5,0)
8	STABILITY	Y VARCHAR2(1)
9	TEMPERATURE	Y NUMBER(5,1)
10	PRESSURE	Y NUMBER(6,2)
11	HUMIDITY	Y NUMBER(4,1)
12	CLOUD_HEIGHT	Y NUMBER(5,0)
13	CLUSTER_HEIGHT	Y NUMBER(5,0)
14	CURRENT_FLAG	Y VARCHAR2(1)
15	CLOUD_COVER	Y NUMBER(2,0)
16	SOLAR_RAD	Y NUMBER(7,1)
17	XMIT_INIT_DATE	Y DATE 7
18	WIND_SIGMA	Y NUMBER(9,2)

Table Name

MET_PARAMETER

This is the Weather database area that contains weather related information.

Sequence	Name	N Format
1	MET_PARAM_CODE	N VARCHAR2(2)
2	MET_PARAM_DESCRIPTION	N VARCHAR2(127)

Table Name

MET_TOWER

The Met Tower table contains information about the sensors on the tower.

Sequence	Name	N Format
1	TOWER_NAME	N VARCHAR2(30)
2	TOWER_CODE	N VARCHAR2(9)
3	TOWER_DESCRIPTION	Y VARCHAR2(127)
4	TOWER_STATUS	Y VARCHAR2(127)
5	XMIT_INIT_DATE	Y DATE 7

Table Name

MUNITION

The Munition table describes the munitions that are commonly stored with chemical weapons.

Sequence	Name	N Format
1	MUNITION_TYPE	N VARCHAR2(4)
2	MUNITION_DESCRIPTION	Y VARCHAR2(127)

Table Name

NAME_SUBSTITUTION

The Name Substitution table controls how case numbers are formulated.

Sequence	Name	N Format
1	SUBST_SOURCE	N VARCHAR2(12)
2	TABLE_NAME	Y VARCHAR2(30)
3	FIELD_NAME	Y VARCHAR2(30)

4	MIN_CHARS	Y NUMBER(2,0)
5	MAX_CHARS	Y NUMBER(2,0)

Table Name
NEXT_OF_KIN

The Next of Kin table contains information about a victims relatives or NOK.

Sequence	Name	N Format
1	TK_REF_NUM	N NUMBER(9,0)
2	NOK_TK_REF_NUM	N NUMBER(9,0)
3	EXERCISE_NUM	N NUMBER(9,0)
4	NOK_RELATIONSHIP	Y NUMBER(2,0)
5	NOK_NOTIFY_FLAG	Y VARCHAR2(1)
6	NOK_ORDER	Y NUMBER(2,0)
7	NOK_COMMENT	Y VARCHAR2(255)
8	EV_NOK_NOTIFY_FLAG	Y VARCHAR2(1)

Table Name
OBJECT_SUBTYPE

The Object Subtype table contains valid subtypes for GIS objects.

Sequence	Name	N Format
1	LOCATION_TYPE	N VARCHAR2(8)
2	FEMIS_OBJECT_SUBTYPE	N VARCHAR2(40)
3	OBJ_SUBTYPE_DESCRIPTION	Y VARCHAR2(127)
4	GIS_SYMBOL_ID	Y NUMBER(9,0)

Table Name
PA_DECISION_MATRIX

The PA Decision Matrix table contains many of the parameters describing the threat that are used to make protective action decisions and recommendations.

Sequence	Name	N Format
1	PA_UNIT_ID	N NUMBER(9,0)
2	EXERCISE_NUM	N NUMBER(9,0)
3	PAD_ID	N NUMBER(9,0)
4	PADM_NAME	Y VARCHAR2(30)
5	THREAT_IMPACT_TIME	Y NUMBER(6,2)
6	THREAT_STASIS_TIME	Y NUMBER(6,2)
7	THREAT_DISTANCE	Y NUMBER(7,0)
8	PADM_TIME	Y NUMBER(6,2)
9	PADM_TYPE	N VARCHAR2(3)
10	DOSE_LEVEL	Y VARCHAR2(40)
11	PADM_TIME_SOURCE	Y VARCHAR2(2)
12	THREAT_REMAIN_TIME	Y NUMBER(6,2)
13	HAZARD_ID	Y NUMBER(9,0)
14	PROT_ACT_INDEX	Y NUMBER(2,0)
15	SS_ID	Y NUMBER(9,0)
16	PLAN_REF_ID	Y NUMBER(9,0)
17	THREAT_ID	Y NUMBER(9,0)

18	ZONE_RISK_GROUP_NAME	Y VARCHAR2(30)
19	IN_RISK_GROUP_FLAG	Y VARCHAR2(1)
20	XMIT_INIT_DATE	Y DATE 7

Table Name

PA_LOOKUP

The PA Lookup table contains protective action recommendations for each protective action unit.

Sequence	Name	N Format
1	PA_UNIT_ID	N NUMBER(9,0)
2	HAZARD_ID	N NUMBER(9,0)
3	PROT_ACT_INDEX	N NUMBER(2,0)
4	SS_ID	N NUMBER(9,0)
5	EXERCISE_NUM	N NUMBER(9,0)
6	PAL_BEGIN_TIME	Y NUMBER(6,2)
7	PAL_END_TIME	Y NUMBER(6,2)
8	PAU_TYPE	N VARCHAR2(10)

Table Name

PA_UNIT

The PA Unit table contains a list of protective action units for use in planning.

Sequence	Name	N Format
1	PA_UNIT_ID	N NUMBER(9,0)
2	EXERCISE_NUM	N NUMBER(9,0)
3	PAU_TYPE	N VARCHAR2(10)
4	ZONE_NAME	N VARCHAR2(30)
5	FACILITY_NAME	Y VARCHAR2(30)
6	XMIT_INIT_DATE	Y DATE 7
7	POLYGONAL_LAYER_ID	N NUMBER(9,0)

Table Name

PD_LEVEL

The PD Level table contains identifying information for each level of the plan.

Sequence	Name	N Format
1	LEVEL_NUM	N NUMBER(1,0)
2	LEVEL_NAME	N VARCHAR2(30)

Table Name

PERSON

The Person table contains information about people that interact with FEMIS.

Sequence	Name	N Format
1	PERSON_REF_NUM	N NUMBER(9,0)
2	EXERCISE_NUM	N NUMBER(9,0)
3	NAME_LAST	Y VARCHAR2(20)
4	NAME_FIRST	Y VARCHAR2(12)

5	NAME_SECOND	Y VARCHAR2(12)
6	HOME_PHONE	Y VARCHAR2(30)
7	WORK_PHONE	Y VARCHAR2(30)
8	PERSON_EMAIL_ADDRESS	Y VARCHAR2(80)
9	PERSON_FAX_PHONE	Y VARCHAR2(30)
10	PERSON_BEEPER_PHONE	Y VARCHAR2(30)
11	PERSON_WORK_HOURS	Y VARCHAR2(30)
12	PERSON_STATUS	Y VARCHAR2(30)
13	PERSON_COMMENT	Y VARCHAR2(255)
14	PERSONAL_ID_NUM	Y VARCHAR2(15)
15	PERSON_NICK_NAME	Y VARCHAR2(12)
16	STATE_CODE	Y VARCHAR2(2)
17	CITY_NAME	Y VARCHAR2(20)
18	STREET_ADDRESS1	Y VARCHAR2(40)
19	STREET_ADDRESS2	Y VARCHAR2(40)
20	ZIP_CODE	Y VARCHAR2(10)
21	HOME_STATE_CODE	Y VARCHAR2(2)
22	HOME_CITY_NAME	Y VARCHAR2(20)
23	HOME_STREET_ADDRESS1	Y VARCHAR2(40)
24	HOME_STREET_ADDRESS2	Y VARCHAR2(40)
25	HOME_ZIP_CODE	Y VARCHAR2(10)
26	HOME_ZONE	Y VARCHAR2(30)
27	WORK_ZONE	Y VARCHAR2(30)
28	CEL_PHONE	Y VARCHAR2(30)
29	EMAIL_ADDRESS2	Y VARCHAR2(80)
30	WEB_ADDRESS	Y VARCHAR2(255)
31	AGENCY_CODE	Y NUMBER(9,0)
32	DEPT_CODE	Y NUMBER(9,0)
33	WK_POSITION_ID	Y NUMBER(9,0)

Table Name

PERSON_SHELTERED

The Person Sheltered table contains identifying information about the evacuee.

Sequence	Name	N Format
1	EV_TP_REF_NUM	N NUMBER(9,0)
2	EV_MOD_DATE	N DATE 7
3	EXERCISE_NUM	N NUMBER(9,0)
4	EV_LOCATION_FROM	Y VARCHAR2(60)
5	EV_PER_EFFECTS_NUM	Y VARCHAR2(12)
6	EV_ARRIVAL_DATE	Y DATE 7
7	EV_DEPART_DATE	Y DATE 7
8	EV_OK_RELEASE_FLAG	Y VARCHAR2(1)
9	UPDATE_PERSON_REF_NUM	Y NUMBER(9,0)
10	EV_STATUS_CODE	Y NUMBER(1,0)
11	POST_EV_STREET_ADDRESS1	Y VARCHAR2(40)
12	POST_EV_STREET_ADDRESS2	Y VARCHAR2(40)
13	POST_EV_CITY_NAME	Y VARCHAR2(20)
14	POST_EV_COUNTY_NAME	Y VARCHAR2(20)
15	POST_EV_STATE_CODE	Y VARCHAR2(2)
16	POST_EV_ZIP_CODE	Y VARCHAR2(10)
17	POST_EV_PHONE	Y VARCHAR2(30)
18	MEDICAL_STATUS	Y VARCHAR2(40)

19	SP_MEDICAL_NEEDS	Y VARCHAR2 (2000)
20	EV_CONTAMINATED_IND	Y VARCHAR2 (1)
21	EV_DECONTAM_FLAG	Y VARCHAR2 (1)
22	DESTINATION_IND	Y VARCHAR2 (1)
23	EV_NOTES	Y VARCHAR2 (2000)
24	MASS_CARE_FACILITY	Y VARCHAR2 (30)
25	MASS_CARE_SHELTER	Y VARCHAR2 (30)
26	RECEP_CNTR_FACILITY	Y VARCHAR2 (30)
27	RECEP_CNTR_SHELTER	Y VARCHAR2 (30)
28	XMIT_INIT_DATE	Y DATE 7
29	NOK_NOTIFY_FLAG	Y VARCHAR2 (1)
30	EOC_NAME	Y VARCHAR2 (30)

Table Name

PLAN_APPROACH

The Plan Approach table contains the pairing of a method and an approach for an electronic plan.

Sequence	Name	N Format
1	METHOD_TYPE	N VARCHAR2 (20)
2	PLANNING_APPROACH	N VARCHAR2 (40)

Table Name

PLAN_CONTROL

The Plan Control table contains control information about an electronic plan.

Sequence	Name	N Format
1	DATASET_NAME	N VARCHAR2 (20)
2	DATASET_END_DATE	Y DATE 7
3	DATASET_START_DATE	Y DATE 7
4	DATASET_DESCRIPTION	Y VARCHAR2 (127)

Table Name

PLAN_DETAIL

The Plan Detail table contains the lower level detail of an electronic plan.

Sequence	Name	N Format
1	PLAN_REF_ID	N NUMBER (9,0)
2	EXERCISE_NUM	N NUMBER (9,0)
3	PD_UNIQUE_REF_NUM	N NUMBER (7,0)
4	PD_NAME	Y VARCHAR2 (254)
5	PD_DESCRIPTION	Y VARCHAR2 (2000)
6	RESPONSIBLE_AGENCY	Y NUMBER (9,0)
7	RESPONSIBLE_DEPT	Y NUMBER (9,0)
8	RESPONSIBLE_POSITION	Y VARCHAR2 (20)
9	RESP_PERSON_REF_NUM	Y NUMBER (9,0)
10	DECISION_POINT	Y VARCHAR2 (1)
11	LOCATION_TO	Y VARCHAR2 (30)
12	START_TIME_TARGET	Y DATE 7
13	FINISH_TIME_TARGET	Y DATE 7
14	DURATION_TARGET	Y NUMBER (8,0)
15	START_TIME_CALC	Y DATE 7

16	FINISH_TIME_CALC	Y DATE 7
17	DURATION_CALC	Y NUMBER(8,0)
18	PD_PRIORITY	Y NUMBER(2,0)
19	EXTERNAL_INTERFACE	Y VARCHAR2(1)
20	PD_NOTES	Y VARCHAR2(1999)
21	PD_COST	Y NUMBER(10,2)
22	LOCATION_TYPE	Y VARCHAR2(8)
23	START_TIME_ACTUAL	Y DATE 7
24	FINISH_TIME_ACTUAL	Y DATE 7
25	DURATION_ACTUAL	Y NUMBER(8,0)
26	PD_ORIGIN	Y VARCHAR2(10)
27	PD_OPS_STATUS	Y VARCHAR2(15)
28	LOGGED_EVENT_FLAG	Y VARCHAR2(1)
29	PD_SEQUENCE_NUM	Y NUMBER(10,0)
30	START_TIME_BASELINE	Y DATE 7
31	FINISH_TIME_BASELINE	Y DATE 7
32	DURATION_BASELINE	Y NUMBER(8,0)
33	PLANNING_STAGE	Y VARCHAR2(30)
34	PLANNING_PHASE	Y VARCHAR2(20)
35	LEVEL_NUM	N NUMBER(1,0)
36	EMERGENCY_SUPPORT_FN	Y VARCHAR2(30)

Table Name

PLAN_HEADER

The Plan Header table contains high level, header information about an electronic plan.

Sequence	Name	N Format
1	PLAN_REF_ID	N NUMBER(9,0)
2	EXERCISE_NUM	N NUMBER(9,0)
3	PLAN_CHANGE_DATE	Y DATE 7
4	PLAN_NAME	N VARCHAR2(64)
5	PLAN_STATUS	Y VARCHAR2(11)
6	EOC_NAME	Y VARCHAR2(30)
7	PLAN_DESCRIPTION	Y VARCHAR2(254)
8	MAX_TASK_REF_NUM	Y NUMBER(7,0)
9	MAX_TASK_SEQUENCE_NUM	Y NUMBER(10,0)
10	PLAN_NOTE	Y VARCHAR2(1999)
11	METHOD_TYPE	Y VARCHAR2(20)
12	PLANNING_APPROACH	Y VARCHAR2(40)
13	PLANNING_GOAL	Y VARCHAR2(40)
14	HAZARD_ID	Y NUMBER(9,0)

Table Name

PLUME

The Plume table contains the identifier and location of a plume from a D2 model.

Sequence	Name	N Format
1	D2_CASE_ID	N NUMBER(9,0)
2	D2_LEVEL_NUM	N NUMBER(2,0)
3	LEVEL_TYPE	N VARCHAR2(1)
4	EXERCISE_NUM	N NUMBER(9,0)

5	PLUME_LOCATION_NAME	Y VARCHAR2 (30)
6	LOCATION_TYPE	Y VARCHAR2 (8)
7	PLUME_NAME	Y VARCHAR2 (30)
8	DOSE_LEVEL	Y VARCHAR2 (40)
9	D2_O_DOS_MAXDIST	Y NUMBER(10,2)
10	XMIT_INIT_DATE	Y DATE 7

Table Name
POLYGONAL_LAYER

Sequence	Name	N Format
1	POLYGONAL_LAYER_ID	N NUMBER(9,0)
2	GIS_LAYER_NAME	Y VARCHAR2 (30)
3	EXERCISE_NUM	Y NUMBER(9,0)
4	EOC_NAME	Y VARCHAR2 (30)

Table Name
POSITION

Sequence	Name	N Format
1	POSITION_CODE	N VARCHAR2 (20)
2	EOC_NAME	N VARCHAR2 (30)
3	POSITION_EMAIL_ADDRESS	Y VARCHAR2 (40)
4	POSITION_DESCRIPTION	Y VARCHAR2 (255)
5	POSITION_PHONE	Y VARCHAR2 (30)
6	XMIT_INIT_DATE	Y DATE 7

Table Name
POSITION_ASSIGNMENT

The Assignment table shows the valid operator positions that a person may assume.

Sequence	Name	N Format
1	PERSON_REF_NUM	N NUMBER(9,0)
2	EXERCISE_NUM	N NUMBER(9,0)
3	POSITION_CODE	N VARCHAR2 (20)
4	EOC_NAME	N VARCHAR2 (30)
5	ASSIGN_LOCATION	Y VARCHAR2 (92)

Table Name
POSITION_PRIV

The Position Privilege table has the mapping of operator positions and privileges.

Sequence	Name	N Format
1	POSITION_CODE	N VARCHAR2 (20)
2	EOC_NAME	N VARCHAR2 (30)
3	CP_NAME	N VARCHAR2 (60)
4	PRIV_NUM	N NUMBER(2,0)

Table Name

POTENTIAL_ACCIDENT

The Potential Accident table describes the potential accident arising from a work plan activity.

Sequence	Name	N	Format
1	LOCAL_ID_CODE	N	VARCHAR2 (20)
2	EXERCISE_NUM	N	NUMBER (9,0)
3	AGENT_CODE	Y	VARCHAR2 (2)
4	ACCIDENT_DESCRIPTION	Y	VARCHAR2 (127)
5	XMIT_INIT_DATE	Y	DATE 7
6	LID_EOC_NAME	Y	VARCHAR2 (30)
7	LID_IGLOO	Y	VARCHAR2 (30)
8	LID_DISTANCE_FROM_IGLOO	Y	NUMBER (8,2)
9	LID_DIRECTION_FROM_IGLOO	Y	VARCHAR2 (2)
10	LID_LATITUDE	Y	NUMBER (12,6)
11	LID_LONGITUDE	Y	NUMBER (12,6)
12	EOC_NAME	Y	VARCHAR2 (30)

Table Name

POTENTIAL_THREAT

The Potential Threat table describes potential threats arising from an accident.

Sequence	Name	N	Format
1	THREAT_ID	N	NUMBER (9,0)
2	EXERCISE_NUM	N	NUMBER (9,0)
3	THREAT_DATE	Y	DATE 7
4	THREAT_CAT_TYPE	Y	VARCHAR2 (20)
5	THREAT_AREA_TYPE	Y	VARCHAR2 (20)
6	THREAT_CAT_DESCRIPTION	Y	VARCHAR2 (127)
7	WEDGE_PG_ID	Y	NUMBER (9,0)
8	D2_CASE_ID	Y	NUMBER (9,0)
9	D2_LEVEL_NUM	Y	NUMBER (2,0)
10	LEVEL_TYPE	Y	VARCHAR2 (1)
11	XMIT_INIT_DATE	Y	DATE 7
12	HAZARD_ID	Y	NUMBER (9,0)
13	EOC_NAME	Y	VARCHAR2 (30)

Table Name

PRIVILEGE

The Privilege table describes the authorities and roles of the user.

Sequence	Name	N	Format
1	CP_NAME	N	VARCHAR2 (60)
2	PRIV_NUM	N	NUMBER (2,0)
3	CREATE_FLAG	N	VARCHAR2 (1)
4	EDIT_FLAG	N	VARCHAR2 (1)
5	BROWSE_FLAG	N	VARCHAR2 (1)
6	HAZARD_ID	Y	NUMBER (9,0)
7	XMIT_INIT_DATE	Y	DATE 7

Table Name

PROGRAM_LOCK

The Program Locking table controls multi-user locking.

Sequence	Name	N Format
1	LOCK_NAME	N VARCHAR2(40)
2	LOCK_ITEM	N VARCHAR2(80)
3	EXERCISE_NUM	N NUMBER(9,0)
4	LOCK_TYPE	Y VARCHAR2(10)
5	LOCK_USER	Y VARCHAR2(8)
6	LOCK_DATE	Y DATE 7
7	LOCK_PC	Y VARCHAR2(40)
8	LOCK_PROGRAM	Y VARCHAR2(40)

Table Name

PROTECTIVE_ACTION

The Protective Action table describes the protective action activities that are to be used or have been recommended for use.

Sequence	Name	N Format
1	HAZARD_ID	N NUMBER(9,0)
2	PROT_ACT_INDEX	N NUMBER(2,0)
3	PROT_ACT_NAME	Y VARCHAR2(60)
4	PROT_ACT_ABBREV	Y VARCHAR2(16)
5	PROT_ACT_DESC	Y VARCHAR2(127)
6	XMIT_INIT_DATE	Y DATE 7

Table Name

REGULATION

The Regulation table contains a list of regulations that relate to FEMIS operations.

Sequence	Name	N Format
1	PLANNING_GOAL	N VARCHAR2(40)
2	REGULATION_CODE	N VARCHAR2(20)
3	REGULATION_DESCRIPTION	Y VARCHAR2(127)

Table Name

RELEASE

The Release table describes the agent released from a potential accident.

Sequence	Name	N Format
1	LOCAL_ID_CODE	N VARCHAR2(20)
2	EXERCISE_NUM	N NUMBER(9,0)
3	RELEASE_NUM	N NUMBER(2,0)
4	QUANTITY_PER_RELEASE	Y NUMBER(13,2)
5	RELEASE_TYPE	N VARCHAR2(3)
6	QUANTITY_PER_RELEASE_SRC	Y VARCHAR2(1)
7	MUNITIONS_IN_RELEASE	Y NUMBER(6,2)
8	MUNITION_TYPE	Y VARCHAR2(4)
9	HEIGHT_OF_STACK	Y NUMBER(7,3)

10	DIAMETER_OF_STACK	Y	NUMBER(7,3)
11	TEMPERATURE_OF_STACK	Y	NUMBER(6,3)
12	VELOCITY_OF_EFFLUENT	Y	NUMBER(6,3)
13	EFFLUENT_RELATIVE_DENSITY	Y	NUMBER(6,3)
14	OUTPUT_CODE	Y	NUMBER(1,0)
15	CLOUD_RADIUS	Y	NUMBER(8,2)
16	HEAT_RELEASED	Y	NUMBER(11,2)
17	TIME_OF_EVAPORATION	Y	NUMBER(6,2)
18	SURFACE_TYPE	Y	VARCHAR2(3)
19	AREA_OF_PUDDLE	Y	NUMBER(7,3)
20	LENGTH_OF_PUDDLE	Y	NUMBER(7,3)
21	HEIGHT_OF_SOURCE	Y	NUMBER(8,2)
22	HEIGHT_OF_SOURCE_SRC	Y	VARCHAR2(1)
23	SIGMA_X	Y	NUMBER(8,2)
24	SIGMA_X_SRC	Y	VARCHAR2(1)
25	SIGMA_Y	Y	NUMBER(8,2)
26	SIGMA_Y_SRC	Y	VARCHAR2(1)
27	SIGMA_Z	Y	NUMBER(8,2)
28	SIGMA_Z_SRC	Y	VARCHAR2(1)
29	TIME_AFTER_FUNCT	Y	NUMBER(6,2)
30	TIME_AFTER_FUNCT_SRC	Y	VARCHAR2(1)
31	XMIT_INIT_DATE	Y	DATE 7

Table Name
REPLICATION_TEST

Sequence	Name	N	Format
1	POINT_NAME	N	VARCHAR2(30)
2	EXERCISE_NUM	N	NUMBER(9,0)
3	POINT_DESCRIPTION	Y	VARCHAR2(127)

Table Name
RESOURCE_ASSIGNMENT

The Resource Assignment table shows the resources assigned to the details of an electronic plan.

Sequence	Name	N	Format
1	PLAN_REF_ID	N	NUMBER(9,0)
2	EXERCISE_NUM	N	NUMBER(9,0)
3	PD_UNIQUE_REF_NUM	N	NUMBER(7,0)
4	PD_RESOURCE_NUM	N	NUMBER(3,0)
5	RESOURCE_REF_NUM	Y	NUMBER(9,0)
6	RESOURCE_QUANTITY	Y	NUMBER(10,0)
7	RESOURCE_NOTE	Y	VARCHAR2(127)
8	LOCATION_FROM	Y	VARCHAR2(30)
9	LOCATION_TYPE	Y	VARCHAR2(8)
10	RESPONSIBLE_EOC	Y	VARCHAR2(30)
11	PLAN_RESOURCE_DISPOS	Y	VARCHAR2(30)
12	PLAN_RESOURCE_ID	Y	NUMBER(9,0)
13	PLAN_POC_AGENCY	Y	NUMBER(9,0)
14	PLAN_POC_DEPT	Y	NUMBER(9,0)
15	PLAN_POC_POSITION	Y	VARCHAR2(30)

Table Name

RESOURCE_CATEGORY

This is the validation data for the types of resources.

Sequence	Name	N	Format
1	RESOURCE_CATEGORY	N	VARCHAR2 (20)
2	RESOURCE_DESCRIPTION	N	VARCHAR2 (127)
3	GIS_SYMBOL_ID	Y	NUMBER (9,0)
4	XMIT_INIT_DATE	Y	DATE 7

Table Name

RESOURCE_DEFINITION

This is the validation data for the types of resources.

Sequence	Name	N	Format
1	RESOURCE_REF_NUM	N	NUMBER (9,0)
2	EXERCISE_NUM	N	NUMBER (9,0)
3	EOC_NAME	Y	VARCHAR2 (30)
4	RESOURCE_NAME	Y	VARCHAR2 (40)
5	RESOURCE_DESCRIPTION	Y	VARCHAR2 (127)
6	RESOURCE_REUSE_FLAG	Y	VARCHAR2 (1)
7	RESOURCE_USE_LIMITATION	Y	VARCHAR2 (254)
8	RESOURCE_MOBILITY_FLAG	Y	VARCHAR2 (1)
9	RESOURCE_DEFAULT_UNITS	Y	VARCHAR2 (10)
10	RESOURCE_CAPACITY_TYPE	Y	VARCHAR2 (10)
11	RESOURCE_CAPACITY_VALUE	Y	NUMBER (10,0)
12	RESOURCE_CAPACITY_UNITS	Y	VARCHAR2 (10)
13	RESOURCE_CATEGORY	N	VARCHAR2 (20)
14	XMIT_INIT_DATE	Y	DATE 7

Table Name

RESOURCE_LOCATION

The Resource Location table describes the amount and kind of resource found at a location.

Sequence	Name	N	Format
1	RESOURCE_REF_NUM	N	NUMBER (9,0)
2	OWNER_CODE	N	NUMBER (9,0)
3	RESOURCE_BATCH_ID	N	NUMBER (9,0)
4	EXERCISE_NUM	N	NUMBER (9,0)
5	FEMIS_OBJECT_NAME	N	VARCHAR2 (30)
6	RESOURCE_COLLECTION	N	VARCHAR2 (20)
7	RESOURCE_STATUS	N	VARCHAR2 (10)
8	EOC_NAME	Y	VARCHAR2 (30)
9	LOCATION_TYPE	Y	VARCHAR2 (8)
10	RESOURCE_QUANTITY	Y	NUMBER (9,0)
11	MOU_ID	Y	NUMBER (9,0)
12	RESOURCE_MOBILIZATION_TIME	Y	NUMBER (5,0)
13	RESOURCE_DISPOSITION	Y	VARCHAR2 (20)
14	RESOURCE_ACTIVATION_MINUTES	Y	NUMBER (5,0)
15	RESPONSIBLE_EOC	Y	VARCHAR2 (30)
16	XMIT_INIT_DATE	Y	DATE 7

Table Name
RESOURCE_MOU

The Resource MOU table describes Memos of Understanding for a resource.

Sequence	Name	N Format
1	RESOURCE_REF_NUM	N NUMBER(9,0)
2	MOU_ID	N NUMBER(9,0)
3	EXERCISE_NUM	N NUMBER(9,0)
4	OWNER_CODE	N NUMBER(9,0)
5	RESOURCE_BATCH_ID	N NUMBER(9,0)
6	RESOURCE_COLLECTION	N VARCHAR2(20)
7	XMIT_INIT_DATE	Y DATE 7

Table Name
RESOURCE_OWNER

The Resource Owner table describes Agencies, Departments and points of contact for a resource.

Sequence	Name	N Format
1	RESOURCE_REF_NUM	N NUMBER(9,0)
2	OWNER_CODE	N NUMBER(9,0)
3	RESOURCE_BATCH_ID	N NUMBER(9,0)
4	EXERCISE_NUM	N NUMBER(9,0)
5	RESOURCE_COLLECTION	N VARCHAR2(20)
6	EOC_NAME	Y VARCHAR2(30)
7	RESOURCE_QUANTITY_ASSIGNED	Y NUMBER(10,2)
8	RESOURCE_QUANTITY_AVAILABLE	Y NUMBER(10,2)
9	RESOURCE_UNITS	Y VARCHAR2(10)
10	RESOURCE_PER_UNIT_VALUE	Y NUMBER(10,2)
11	RESOURCE_POC_AGENCY	Y NUMBER(9,0)
12	RESOURCE_POC_DEPT	Y NUMBER(9,0)
13	RESOURCE_POC_POSITION	Y NUMBER(9,0)
14	RESOURCE_POC_PERSON_REF_NUM	Y NUMBER(9,0)
15	RESOURCE_POC_PHONE	Y VARCHAR2(17)
16	RESOURCE_CRITICAL_LEVEL	Y NUMBER(9,0)
17	RESOURCE_NOTES	Y VARCHAR2(254)
18	XMIT_INIT_DATE	Y DATE 7

Table Name
ROAD_QUALIFICATION

The Road Qualification table contains information about a roadway used for Evac modeling.

Sequence	Name	N Format
1	EXERCISE_NUM	N NUMBER(9,0)
2	ROAD_CLASS	N VARCHAR2(2)
3	RQ_INCLUDE_FLAG	Y CHAR(10)
4	RQ_FREE_FLOW_SPEED	Y CHAR(10)
5	RQ_LANE_COUNT	Y CHAR(10)
6	RQ_DIVIDED_FLAG	Y CHAR(10)
7	RQ_DEFAULT_FLAG	Y CHAR(10)

Table Name

ROUTE

The Route table contains information about a road or highway used for Evac modeling.

Sequence	Name	N Format
1	EXERCISE_NUM	N NUMBER(9,0)
2	ROUTE_NAME	N VARCHAR2(30)
3	ROUTE_DESCRIPTION	Y VARCHAR2(127)
4	ROUTE_FLAG	Y VARCHAR2(1)
5	ROUTE_TO_LOCATION	Y VARCHAR2(30)
6	ROUTE_FROM_LOCATION	Y VARCHAR2(30)

Table Name

ROUTE_SEGMENT

The Route Segment table contains information about a road segment used for Evac modeling.

Sequence	Name	N Format
1	EXERCISE_NUM	N NUMBER(9,0)
2	ROUTE_NAME	N VARCHAR2(30)
3	ROUTE_SEG_NUM	N NUMBER(6,0)
4	ROUTE_SEG_LOCATION	Y VARCHAR2(92)
5	RS_TO_LOCATION	Y VARCHAR2(92)
6	RS_FROM_LOCATION	Y VARCHAR2(92)
7	RS_ID	Y NUMBER(7,0)

Table Name

SHELTER

The Shelter table contains information about a facility that can operate as a shelter.

Sequence	Name	N Format
1	FACILITY_NAME	N VARCHAR2(30)
2	EXERCISE_NUM	N NUMBER(9,0)
3	SHELTER_NAME	N VARCHAR2(30)
4	SHELTER_ACTIVATION_DATE	Y DATE 7
5	SHELTER_DEACTIVATION_DATE	Y DATE 7
6	SHELTER_DESCRIPTION	Y VARCHAR2(255)
7	SHELTER_CAPACITY	Y NUMBER(5,0)
8	SHELTER_TYPE	N VARCHAR2(10)
9	XMIT_INIT_DATE	Y DATE 7
10	EOC_NAME	Y VARCHAR2(30)

Table Name

SHELTER_DEFINITION

The Shelter Definition table defines capabilities of a shelter used for evacuation.

Sequence	Name	N	Format
1	SHELTER_TYPE	N	VARCHAR2 (10)
2	SHELTER_TYPE_DESCRIPTION	Y	VARCHAR2 (127)

Table Name

SITUATION_SUMMARY

The Situation Summary table contains information about conditions present at the onset of a planned or actual emergency.

Sequence	Name	N	Format
1	SS_ID	N	NUMBER (9,0)
2	EXERCISE_NUM	N	NUMBER (9,0)
3	SS_NAME	Y	VARCHAR2 (127)
4	COMBO_VALUE_1	Y	VARCHAR2 (30)
5	COMBO_VALUE_2	Y	VARCHAR2 (30)
6	COMBO_VALUE_3	Y	VARCHAR2 (30)
7	COMBO_VALUE_4	Y	VARCHAR2 (30)
8	COMBO_VALUE_5	Y	VARCHAR2 (30)
9	COMBO_VALUE_6	Y	VARCHAR2 (30)
10	TEXT_VALUE_1	Y	VARCHAR2 (256)
11	TEXT_VALUE_2	Y	VARCHAR2 (256)
12	TEXT_VALUE_3	Y	VARCHAR2 (256)
13	TEXT_VALUE_4	Y	VARCHAR2 (256)
14	TEXT_VALUE_5	Y	VARCHAR2 (256)
15	TEXT_VALUE_6	Y	VARCHAR2 (256)
16	HAZARD_ID	Y	NUMBER (9,0)
17	PROT_ACT_INDEX	Y	NUMBER (2,0)
18	XMIT_INIT_DATE	Y	DATE 7

Table Name

STATE

The State table contains information about the states of the USA.

Sequence	Name	N	Format
1	STATE_CODE	N	VARCHAR2 (2)
2	STATE_NAME	Y	VARCHAR2 (15)
3	STATE_FIPS_CODE	Y	VARCHAR2 (2)

Table Name

STORED_AGENT

The Stored Agent table contains information about agents stored at a CSEPP site.

Sequence	Name	N	Format
1	BUNKER_NAME	N	VARCHAR2 (30)
2	AGENT_CODE	N	VARCHAR2 (2)

3	MUNITION_TYPE	N VARCHAR2(4)
4	MUNITION_QUANTITY	Y NUMBER(6,0)
5	MUNITION_QUANTITY_UNITS	Y VARCHAR2(30)
6	XMIT_INIT_DATE	Y DATE 7

Table Name
SYSTEM_MODE

The System Mode table contains a list of the modes that FEMIS can assume.

Sequence	Name	N Format
1	MODE_NAME	N VARCHAR2(10)
2	MODE_DEFAULT_FLAG	N VARCHAR2(1)
3	MODE_DESCRIPTION	Y VARCHAR2(127)
4	MODE_SEQUENCE	Y NUMBER(2,0)

Table Name
SYSTEM_PHASE

The System Phase table contains a list of the Phases that FEMIS can assume.

Sequence	Name	N Format
1	MODE_NAME	N VARCHAR2(10)
2	MODE_DEFAULT_FLAG	N VARCHAR2(1)
3	PHASE_NAME	N VARCHAR2(20)
4	PHASE_DEFAULT_FLAG	N VARCHAR2(1)
5	PHASE_DESCRIPTION	Y VARCHAR2(127)
6	PHASE_SEQUENCE	Y NUMBER(2,0)

Table Name
SYSTEM_STAGE

The System Stage table contains a list of the stages that FEMIS can assume.

Sequence	Name	N Format
1	MODE_NAME	N VARCHAR2(10)
2	MODE_DEFAULT_FLAG	N VARCHAR2(1)
3	PHASE_NAME	N VARCHAR2(20)
4	PHASE_DEFAULT_FLAG	N VARCHAR2(1)
5	STAGE_NAME	N VARCHAR2(30)
6	STAGE_DEFAULT_FLAG	N VARCHAR2(1)
7	BUTTON_SEQUENCE	N NUMBER(2,0)
8	STAGE_DESCRIPTION	Y VARCHAR2(127)
9	BUTTON_TEXT	Y VARCHAR2(32)
10	BUTTON_FUNCTION	Y VARCHAR2(10)
11	STAGE_SEQUENCE	Y NUMBER(2,0)

Table Name

TRACKED_PERSON

The Tracked Person table contains the names and addresses of accident victims or their next of kin.

Sequence	Name	N Format
1	TK_REF_NUM	N NUMBER(9,0)
2	EXERCISE_NUM	N NUMBER(9,0)
3	TK_NAME_FIRST	Y VARCHAR2(12)
4	TK_NAME_LAST	Y VARCHAR2(20)
5	TK_NAME_SECOND	Y VARCHAR2(12)
6	TK_CITY_NAME	Y VARCHAR2(20)
7	TK_STATE_CODE	Y VARCHAR2(2)
8	TK_STREET_ADDRESS1	Y VARCHAR2(40)
9	TK_STREET_ADDRESS2	Y VARCHAR2(40)
10	TK_ZIP_CODE	Y VARCHAR2(10)
11	TK_EMAIL_ADDRESS	Y VARCHAR2(80)
12	TK_FAX_PHONE	Y VARCHAR2(30)
13	TK_HOME_PHONE	Y VARCHAR2(30)
14	TK_BEEPER_PHONE	Y VARCHAR2(30)
15	TK_ISSN	Y VARCHAR2(15)
16	TK_DATE_OF_BIRTH	Y DATE 7
17	TK_GENDER	Y VARCHAR2(1)
18	TK_NICK_NAME	Y VARCHAR2(12)
19	TK_COUNTY_NAME	Y VARCHAR2(20)
20	PT_CASUALTY	Y CHAR(1)
21	PT_EVACUEE	Y CHAR(1)
22	PT_SITE	Y CHAR(1)
23	PT_TRACKED	Y CHAR(1)
24	TK_COMMENT	Y VARCHAR2(255)
25	CEL_PHONE	Y VARCHAR2(30)
26	EMAIL_ADDRESS2	Y VARCHAR2(80)
27	WEB_ADDRESS	Y VARCHAR2(255)

Table Name

T_GIS_LAYER

Sequence	Name	N Format
1	GIS_LAYER_NAME	N VARCHAR2(30)
2	EXERCISE_NUM	N NUMBER(9,0)
3	GIS_LAYER_MODIFICATION_DATE	Y DATE 7
4	GIS_LEGEND_NAME	Y VARCHAR2(32)
5	GIS_LAYER_TYPE	Y VARCHAR2(10)
6	GIS_LAYER_DESCRIPTION	Y VARCHAR2(127)
7	GIS_LAYER_SYMBOL_ID	Y NUMBER(3,0)
8	GIS_LAYER_TEXT_FONT	Y NUMBER(3,0)
9	GIS_LAYER_TEXT_COLOR	Y NUMBER(3,0)
10	GIS_LAYER_TEXT_ROTATION	Y NUMBER(3,0)
11	GIS_LAYER_TEXT_SIZE	Y NUMBER(3,0)
12	GIS_LAYER_TEXT_JUSTIFY	Y VARCHAR2(2)
13	GIS_LAYER_SYMBOL_COLOR	Y NUMBER(3,0)
14	GIS_LAYER_SYMBOL_SIZE	Y NUMBER(3,0)
15	GIS_LAYER_BACK_COLOR	Y NUMBER(3,0)

16	GIS_LAYER_FORE_COLOR	Y NUMBER(3,0)
17	GENERIC_GIS_LAYER_CODE	Y VARCHAR2(2)
18	SOURCE	Y VARCHAR2(127)
19	ORIGINAL_MAP_SCALE	Y NUMBER(9,0)
20	ORIGINAL_MAP_PROJECTION	Y VARCHAR2(127)
21	ACCURACY	Y VARCHAR2(127)
22	LEGEND_ORDER	Y NUMBER(9,2)
23	LABEL_FIELD	Y VARCHAR2(20)
24	OBJ_LOOKUP_CATEGORY	Y VARCHAR2(20)
25	CLASSIFICATION_FIELD	Y VARCHAR2(20)
26	DEFAULT_LEGEND_TYPE	Y VARCHAR2(8)
27	MINIMUM_SCALE	Y NUMBER(9,0)
28	MAXIMUM_SCALE	Y NUMBER(9,0)
29	GIS_LAYER_FILE_PATH	Y VARCHAR2(32)
30	PROCESSING_DETAILS	Y VARCHAR2(2000)
31	HAZARD_ZONE_LAYER_FLAG	Y VARCHAR2(1)
32	LOAD_FLAG	Y VARCHAR2(1)
33	VISIBLE_FLAG	Y VARCHAR2(1)
34	XMIT_INIT_DATE	Y DATE 7
35	DYNAMIC_LAYER_FLAG	Y VARCHAR2(1)
36	EOC_NAME	Y VARCHAR2(30)

Table Name
UDS_COLUMN

Maintains data areas that can be used for the column data for a User Defined Status Board.

Sequence	Name	N Format
1	UDS_NAME	N VARCHAR2(30)
2	EOC_NAME	N VARCHAR2(30)
3	EXERCISE_NUM	N NUMBER(9,0)
4	COLUMN_ID	N NUMBER(9,0)
5	COLUMN_NAME	N VARCHAR2(30)
6	COLUMN_SQL_TYPE	N VARCHAR2(15)
7	TABLE_FROM	Y VARCHAR2(60)
8	COLUMN FROM	Y VARCHAR2(250)
9	SELECTION_STRING	Y VARCHAR2(1000)
10	MAX_LENGTH	Y NUMBER(6,0)
11	DEFAULT_VALUE	Y VARCHAR2(127)
12	GRID_COLUMN_NO	Y NUMBER(6,0)
13	GRID_COLUMN_WIDTH	Y NUMBER(4,0)
14	TITLE	Y VARCHAR2(30)
15	DESCRIP	Y VARCHAR2(127)
16	DATA_TYPE	Y VARCHAR2(30)
17	UDS_CP_NAME	Y VARCHAR2(30)
18	ATTR_FLAGS	Y VARCHAR2(30)
19	MIN_VALUE	Y VARCHAR2(127)
20	MAX_VALUE	Y VARCHAR2(127)
21	SOURCE_TAG	Y VARCHAR2(30)
22	SOURCE_DATA_TYPE	Y VARCHAR2(30)
23	SOURCE_MAX_LENGTH	Y VARCHAR2(4)
24	GRID_COLUMN_HDG	Y VARCHAR2(30)
25	GRID_COLUMN_FLAGS	Y VARCHAR2(30)
26	RECORD_FORMAT	Y VARCHAR2(30)

27	REVISION_NUM	Y NUMBER(,)
28	XMIT_INIT_DATE	Y DATE 7
29	SQL_DATA_TYPE	Y VARCHAR2(30)
30	FORM_FIELD_ATTRIBUTES	Y VARCHAR2(2000)
31	AGGR_PARENT_NAME	Y VARCHAR2(30)
32	AGGR_ITEM_NAME	Y VARCHAR2(30)
33	AGGR_ITEM_ATTRIBUTES	Y VARCHAR2(2000)
34	EXTRA_ATTRIBUTES	Y VARCHAR2(2000)
35	MOD_COUNT	Y NUMBER(8,0)
36	MOD_USERNAME	Y VARCHAR2(60)
37	MOD_USERCODE	Y VARCHAR2(30)
38	GRID_COLUMN_ATTRIBUTES	Y VARCHAR2(2000)
39	MOD_DATE	Y DATE 7
40	HAZARD_ID	N NUMBER(9,0)

Table Name

UDS_ROW

This table contains data areas that can be used for the row data for User Defined Status Boards.

Sequence	Name	N Format
1	UDS_NAME	N VARCHAR2(30)
2	EOC_NAME	N VARCHAR2(30)
3	EXERCISE_NUM	N NUMBER(9,0)
4	UDS_ROW_ID	N NUMBER(9,0)
5	UDS_ROW_CREATE_DATE	Y DATE 7
6	UDS_ROW_MOD_DATE	Y DATE 7
7	UDS_VALUE1	Y VARCHAR2(2000)
8	UDS_VALUE2	Y VARCHAR2(2000)
9	UDS_VALUE3	Y VARCHAR2(2000)
10	UDS_VALUE4	Y VARCHAR2(2000)
11	UDS_VALUE5	Y VARCHAR2(2000)
12	UDS_VALUE6	Y VARCHAR2(2000)
13	UDS_VALUE7	Y VARCHAR2(2000)
14	UDS_VALUE8	Y VARCHAR2(2000)
15	UDS_VALUE9	Y VARCHAR2(2000)
16	UDS_VALUE10	Y VARCHAR2(2000)
17	UDS_ACTUAL_TIME	Y DATE 7
18	CURRENT_RECORD_FLAG	Y VARCHAR2(1)
19	UPDATE_PERSON_REF_NUM	Y NUMBER(9,0)
20	UDS_HISTORY_LINK_ID	Y NUMBER(9,0)
21	UDS_NUMBER1	Y NUMBER(,)
22	UDS_NUMBER2	Y NUMBER(,)
23	UDS_NUMBER3	Y NUMBER(,)
24	UDS_NUMBER4	Y NUMBER(,)
25	UDS_NUMBER5	Y NUMBER(,)
26	UDS_NUMBER6	Y NUMBER(,)
27	UDS_NUMBER7	Y NUMBER(,)
28	UDS_NUMBER8	Y NUMBER(,)
29	UDS_NUMBER9	Y NUMBER(,)
30	UDS_NUMBER10	Y NUMBER(,)
31	UDS_DATETIME1	Y DATE 7
32	UDS_DATETIME2	Y DATE 7

33	UDS_DATETIME3	Y DATE 7
34	UDS_DATETIME4	Y DATE 7
35	UDS_DATETIME5	Y DATE 7
36	UDS_YESNO1	Y VARCHAR2 (1)
37	UDS_YESNO2	Y VARCHAR2 (1)
38	UDS_YESNO3	Y VARCHAR2 (1)
39	UDS_YESNO4	Y VARCHAR2 (1)
40	UDS_YESNO5	Y VARCHAR2 (1)
41	RECORD_FORMAT	Y VARCHAR2 (30)
42	REVISION_NUM	Y NUMBER (,)
43	XMIT_INIT_DATE	Y DATE 7
44	UDS_LOCATION1	Y NUMBER (20,6)
45	UDS_LOCATION2	Y NUMBER (20,6)
46	UDS_LOCATION3	Y NUMBER (20,6)
47	UDS_LOCATION4	Y NUMBER (20,6)
48	UDS_LOCATION5	Y NUMBER (20,6)
49	UDS_DATETIME6	Y DATE 7
50	UDS_DATETIME7	Y DATE 7
51	UDS_DATETIME8	Y DATE 7
52	UDS_DATETIME9	Y DATE 7
53	UDS_DATETIME10	Y DATE 7
54	UDS_VALUE11	Y VARCHAR2 (2000)
55	UDS_VALUE12	Y VARCHAR2 (2000)
56	UDS_VALUE13	Y VARCHAR2 (2000)
57	UDS_VALUE14	Y VARCHAR2 (2000)
58	UDS_VALUE15	Y VARCHAR2 (2000)
59	UDS_VALUE16	Y VARCHAR2 (2000)
60	UDS_VALUE17	Y VARCHAR2 (2000)
61	UDS_VALUE18	Y VARCHAR2 (2000)
62	UDS_VALUE19	Y VARCHAR2 (2000)
63	UDS_VALUE20	Y VARCHAR2 (2000)
64	UDS_VALUE21	Y VARCHAR2 (2000)
65	UDS_VALUE22	Y VARCHAR2 (2000)
66	UDS_VALUE23	Y VARCHAR2 (2000)
67	UDS_VALUE24	Y VARCHAR2 (2000)
68	UDS_VALUE25	Y VARCHAR2 (2000)
69	UDS_VALUE26	Y VARCHAR2 (2000)
70	UDS_VALUE27	Y VARCHAR2 (2000)
71	UDS_VALUE28	Y VARCHAR2 (2000)
72	UDS_VALUE29	Y VARCHAR2 (2000)
73	UDS_VALUE30	Y VARCHAR2 (2000)
74	UDS_VALUE31	Y VARCHAR2 (2000)
75	UDS_VALUE32	Y VARCHAR2 (2000)
76	UDS_VALUE33	Y VARCHAR2 (2000)
77	UDS_VALUE34	Y VARCHAR2 (2000)
78	UDS_VALUE35	Y VARCHAR2 (2000)
79	UDS_VALUE36	Y VARCHAR2 (2000)
80	UDS_VALUE37	Y VARCHAR2 (2000)
81	UDS_VALUE38	Y VARCHAR2 (2000)
82	UDS_VALUE39	Y VARCHAR2 (2000)
83	UDS_VALUE40	Y VARCHAR2 (2000)
84	UDS_NUMBER11	Y NUMBER (,)
85	UDS_NUMBER12	Y NUMBER (,)
86	UDS_NUMBER13	Y NUMBER (,)
87	UDS_NUMBER14	Y NUMBER (,)

88	UDS_NUMBER15	Y NUMBER(,)
89	UDS_NUMBER16	Y NUMBER(,)
90	UDS_NUMBER17	Y NUMBER(,)
91	UDS_NUMBER18	Y NUMBER(,)
92	UDS_NUMBER19	Y NUMBER(,)
93	UDS_NUMBER20	Y NUMBER(,)
94	UDS_NUMBER21	Y NUMBER(,)
95	UDS_NUMBER22	Y NUMBER(,)
96	UDS_NUMBER23	Y NUMBER(,)
97	UDS_NUMBER24	Y NUMBER(,)
98	UDS_NUMBER25	Y NUMBER(,)
99	UDS_NUMBER26	Y NUMBER(,)
100	UDS_NUMBER27	Y NUMBER(,)
101	UDS_NUMBER28	Y NUMBER(,)
102	UDS_NUMBER29	Y NUMBER(,)
103	UDS_NUMBER30	Y NUMBER(,)
104	UDS_DATE11	Y DATE 7
105	UDS_DATE12	Y DATE 7
106	UDS_DATE13	Y DATE 7
107	UDS_DATE14	Y DATE 7
108	UDS_DATE15	Y DATE 7
109	UDS_DATE16	Y DATE 7
110	UDS_DATE17	Y DATE 7
111	UDS_DATE18	Y DATE 7
112	UDS_DATE19	Y DATE 7
113	UDS_DATE20	Y DATE 7
114	UDS_YESNO6	Y VARCHAR2(1)
115	UDS_YESNO7	Y VARCHAR2(1)
116	UDS_YESNO8	Y VARCHAR2(1)
117	UDS_YESNO9	Y VARCHAR2(1)
118	UDS_YESNO10	Y VARCHAR2(1)
119	UDS_YESNO11	Y VARCHAR2(1)
120	UDS_YESNO12	Y VARCHAR2(1)
121	UDS_YESNO13	Y VARCHAR2(1)
122	UDS_YESNO14	Y VARCHAR2(1)
123	UDS_YESNO15	Y VARCHAR2(1)
124	UDS_YESNO16	Y VARCHAR2(1)
125	UDS_YESNO17	Y VARCHAR2(1)
126	UDS_YESNO18	Y VARCHAR2(1)
127	UDS_YESNO19	Y VARCHAR2(1)
128	UDS_YESNO20	Y VARCHAR2(1)
129	EXTRA_ATTRIBUTES	Y VARCHAR2(2000)
130	MOD_COUNT	Y NUMBER(8,0)
131	MOD_USERNAME	Y VARCHAR2(60)
132	MOD_USERCODE	Y VARCHAR2(30)
133	MOD_DATE	Y DATE 7
134	HAZARD_ID	N NUMBER(9,0)

Table Name

USER_DEFINED_STATUS

This is the high level description table of a User Defined Status Board.

Sequence	Name	N Format
1	UDS_NAME	N VARCHAR2 (30)
2	EOC_NAME	N VARCHAR2 (30)
3	EXERCISE_NUM	N NUMBER (9,0)
4	UDS_NUM_COLS	Y NUMBER (4,0)
5	UDS_CHANGE_DATE	Y DATE 7
6	UDS_TITLE	Y VARCHAR2 (127)
7	UDS_DEFAULT_PRIV	Y VARCHAR2 (15)
8	UDS_DESCRIP	Y VARCHAR2 (255)
9	UDS_CP_NAME	Y VARCHAR2 (30)
10	UDS_DEFAULT_SORT	Y VARCHAR2 (255)
11	UDS_ATTR_FLAGS	Y VARCHAR2 (30)
12	RECORD_FORMAT	Y VARCHAR2 (30)
13	REVISION_NUM	Y NUMBER (,)
14	XMIT_INIT_DATE	Y DATE 7
15	SHARING_FLAGS	Y VARCHAR2 (30)
16	VISIBILITY_FLAGS	Y VARCHAR2 (30)
17	VISIBILITY_ATTRIBUTES	Y VARCHAR2 (2000)
18	RELATION_ATTRIBUTES1	Y VARCHAR2 (2000)
19	RELATION_ATTRIBUTES2	Y VARCHAR2 (2000)
20	RELATION_ATTRIBUTES3	Y VARCHAR2 (2000)
21	RELATION_ATTRIBUTES4	Y VARCHAR2 (2000)
22	RELATION_ATTRIBUTES5	Y VARCHAR2 (2000)
23	RELATION_STRING1	Y VARCHAR2 (2000)
24	RELATION_STRING2	Y VARCHAR2 (2000)
25	RELATION_STRING3	Y VARCHAR2 (2000)
26	RELATION_STRING4	Y VARCHAR2 (2000)
27	RELATION_STRING5	Y VARCHAR2 (2000)
28	EXTRA_ATTRIBUTES	Y VARCHAR2 (2000)
29	MOD_COUNT	Y NUMBER (8,0)
30	MOD_USERNAME	Y VARCHAR2 (60)
31	MOD_USERCODE	Y VARCHAR2 (30)
32	PRIMARY_DATA_TABLE	Y VARCHAR2 (120)
33	TABLE1_ATTRIBUTES	Y VARCHAR2 (2000)
34	TABLE2_ATTRIBUTES	Y VARCHAR2 (2000)
35	TABLE3_ATTRIBUTES	Y VARCHAR2 (2000)
36	TABLE4_ATTRIBUTES	Y VARCHAR2 (2000)
37	TABLE5_ATTRIBUTES	Y VARCHAR2 (2000)
38	MOD_DATE	Y DATE 7
39	HAZARD_ID	N NUMBER (9,0)

Table Name

USER_MODEL_CASE

The User Model Case table is used to track the cases that a FEMIS user is currently accessing.

Sequence	Name	N Format
1	SITE_NAME	N VARCHAR2 (30)
2	EOC_NAME	N VARCHAR2 (30)

3	EXERCISE_NUM	N	NUMBER(9,0)
4	MODE_NAME	N	VARCHAR2(10)
5	CURRENT_DATASET_NAME	N	VARCHAR2(20)
6	LC_USER_CODE	N	VARCHAR2(8)
7	CASE_TYPE	N	VARCHAR2(4)
8	CASE_ID	N	NUMBER(9,0)
9	XMIT_INIT_DATE	Y	DATE 7

Table Name

USER_MODE_PRIV

The User Mode Privilege table maps the privileges available to a user in the current mode.

Sequence	Name	N	Format
1	CP_NAME	N	VARCHAR2(60)
2	PRIV_NUM	N	NUMBER(2,0)
3	MODE_NAME	N	VARCHAR2(10)
4	MODE_DEFAULT_FLAG	N	VARCHAR2(1)
5	USER_CODE	N	VARCHAR2(8)

Table Name

USER_PREFERENCES

Sequence	Name	N	Format
1	USER_CODE	N	VARCHAR2(8)
2	PREFERENCES_NUM	N	NUMBER(9,0)
3	PREFERENCES_TEXT	Y	VARCHAR2(255)

Table Name

VALIDATION

Sequence	Name	N	Format
1	PLAN_REF_ID	N	NUMBER(9,0)
2	EXERCISE_NUM	N	NUMBER(9,0)
3	VALIDATE_NUM	N	NUMBER(3,0)
4	ERROR_CLASS	Y	VARCHAR2(40)
5	ERROR_DESCRIPTION	Y	VARCHAR2(127)

Table Name

VAL_LIST

The Val List table is used to validate various sets of user entered values.

Sequence	Name	N	Format
1	VL_NAME	N	VARCHAR2(30)
2	VL_TYPE	Y	VARCHAR2(10)
3	VL_DESCRIPTION	Y	VARCHAR2(127)

Table Name

VAL_LIST_DATA

The Val List Data table contains validate sets of system values.

Sequence	Name	N	Format
1	VL_NAME	N	VARCHAR2(30)
2	VLD_SEQUENCE_NO	N	NUMBER(7,0)
3	VLD_TEXT	Y	VARCHAR2(80)
4	VLD_SORT_NO	Y	NUMBER(7,0)

Table Name

VAL_LOCATION_TYPE

The Val Location Type table contains valid location types for objects that can be located at or near another object.

Sequence	Name	N	Format
1	LOCATION_TYPE	N	VARCHAR2(8)
2	VALID_LOCATION_TYPE	N	VARCHAR2(8)
3	REASON_VALID	Y	VARCHAR2(127)

Table Name

VAL_POSITION

The Val Position table is used to validate position descriptions.

Sequence	Name	N	Format
1	POSITION_CODE	N	VARCHAR2(20)
2	POSITION_NAME	Y	VARCHAR2(50)

Table Name

WEDGE_POLYGON

The Wedge or Polygon table contains parameters about the wedge or user defined polygon used for threat analysis.

Sequence	Name	N	Format
1	WEDGE_PG_ID	N	NUMBER(9,0)
2	EXERCISE_NUM	N	NUMBER(9,0)
3	OBJECT_TYPE	Y	VARCHAR2(4)
4	WEDGE_ANGLE	Y	NUMBER(3,0)
5	OBJECT_LOCATION	Y	VARCHAR2(92)
6	LOCATION_TYPE	Y	VARCHAR2(8)
7	WEDGE_PG_DISTANCE	Y	NUMBER(10,2)
8	WEDGE_PG_WIND_DIR	Y	NUMBER(3,0)
9	WEDGE_PG_NAME	Y	VARCHAR2(30)
10	D2_CASE_ID	Y	NUMBER(9,0)
11	D2_LEVEL_NUM	Y	NUMBER(2,0)
12	LEVEL_TYPE	Y	VARCHAR2(1)
13	DOSE_LEVEL	Y	VARCHAR2(40)
14	XMIT_INIT_DATE	Y	DATE 7

Table Name

WK_POSITION

The Work Position table has information about the positions within a department.

Sequence	Name	N	Format
1	WK_POSITION_ID	N	NUMBER(9,0)
2	EXERCISE_NUM	N	NUMBER(9,0)
3	POSITION_TITLE	N	VARCHAR2(40)
4	DEPT_CODE	N	NUMBER(9,0)
5	EOC_NAME	Y	VARCHAR2(30)
6	XMIT_INIT_DATE	Y	DATE 7

Table Name

WORK_PLAN

The Work Plan table has header information about a Work Plan.

Sequence	Name	N	Format
1	WORK_PLAN_ID	N	NUMBER(9,0)
2	EXERCISE_NUM	N	NUMBER(9,0)
3	WP_START_DATE	Y	DATE 7
4	WP_END_DATE	Y	DATE 7
5	WP_COMMENT	Y	VARCHAR2(255)
6	WP_TEAM_COUNT	Y	NUMBER(6,0)
7	LAST_CHANGE_DATE	N	DATE 7
8	LAST_CHANGE_PERSON	N	VARCHAR2(40)
9	XMIT_INIT_DATE	Y	DATE 7

Table Name

WORK_PLAN_ACT

The Work Plan Act is a link between the Work Plan and the activities on the Work Plan.

Sequence	Name	N	Format
1	WORK_PLAN_ID	N	NUMBER(9,0)
2	EXERCISE_NUM	N	NUMBER(9,0)
3	WORK_PLAN_INDEX	N	NUMBER(9,0)
4	WPA_NAME	Y	VARCHAR2(30)
5	WPA_WORST_CASE_FLAG	Y	VARCHAR2(1)
6	WPA_CANCEL_FLAG	Y	VARCHAR2(1)
7	WPA_END_DATE	Y	DATE 7
8	WPA_START_DATE	Y	DATE 7
9	WPA_LOCATION	Y	VARCHAR2(92)
10	LOCATION_TYPE	Y	VARCHAR2(8)
11	WPA_TEAM_COUNT	Y	NUMBER(3,0)
12	D2_CASE_ID	Y	NUMBER(9,0)
13	PAD_ID	Y	NUMBER(9,0)
14	ZONE_RISK_GROUP_NAME	Y	VARCHAR2(30)
15	THREAT_ID	Y	NUMBER(9,0)
16	WPA_COMMENT	Y	VARCHAR2(512)
17	WPA_ACTIVITY_NUM	Y	NUMBER(2,0)
18	EMIS_EVENT_NUM	Y	NUMBER(4,0)
19	WPA_DESCRIPTION	Y	VARCHAR2(254)

20	WPA_AGENT_CODE	Y VARCHAR2 (2)
21	WPA_MUNITION_TYPE	Y VARCHAR2 (4)
22	WPA_MUNITION_IN_ACT	Y NUMBER (7,0)
23	WPA_NOTE	Y VARCHAR2 (254)
24	ACTIVITY_CODE	Y VARCHAR2 (20)
25	LOCAL_ID_CODE	Y VARCHAR2 (20)
26	XMIT_INIT_DATE	Y DATE 7

Table Name

WORK_PLAN_ACTIVITY

The Work Plan Activity table contains information a specific Work Plan item.

Sequence	Name	N Format
1	WPA_ID	N NUMBER (9,0)
2	EXERCISE_NUM	N NUMBER (9,0)
3	WPA_DESCRIPTION	Y VARCHAR2 (254)
4	WPA_AGENT_CODE	Y VARCHAR2 (2)
5	WPA_MUNITION_TYPE	Y VARCHAR2 (4)
6	WPA_MUNITION_IN_ACT	Y NUMBER (7,0)
7	WPA_NOTE	Y VARCHAR2 (254)
8	ACTIVITY_CODE	Y VARCHAR2 (20)
9	LOCAL_ID_CODE	Y VARCHAR2 (20)
10	XMIT_INIT_DATE	Y DATE 7

Table Name

ZONE

The Zone table contains the zones that have been defined for a site.

Sequence	Name	N Format
1	ZONE_NAME	N VARCHAR2 (30)
2	POLYGONAL_LAYER_ID	N NUMBER (9,0)
3	ZONE_TYPE	N VARCHAR2 (5)
4	EMIS_ZONE_NAME	Y VARCHAR2 (80)
5	ZONE_NUMBER	Y NUMBER (9,0)
6	PRIMARY_EOC_NAME	N VARCHAR2 (30)

Table Name

ZONE_CLUSTER_IN_GROUP

Sequence	Name	N Format
1	ZONE_RISK_GROUP_NAME	N VARCHAR2 (30)
2	EXERCISE_NUM	N NUMBER (9,0)
3	EOC_NAME	N VARCHAR2 (30)
4	ZONE_CLUSTER_ID	Y NUMBER (9,0)
5	XMIT_INIT_DATE	Y DATE 7
6	POLYGONAL_LAYER_ID	Y NUMBER (9,0)

Table Name

ZONE_IN_GROUP

The Zone In Group table contains the zones that are in a risk group.

Sequence	Name	N Format
1	ZONE_RISK_GROUP_NAME	N VARCHAR2(30)
2	EXERCISE_NUM	N NUMBER(9,0)
3	ZONE_NAME	N VARCHAR2(30)
4	POLYGONAL_LAYER_ID	N NUMBER(9,0)
5	XMIT_INIT_DATE	Y DATE 7
6	EOC_NAME	Y VARCHAR2(30)

Table Name

ZONE_RISK_GROUP

The Zone Risk Group table contains the names of risk groups commonly used at an EOC.

Sequence	Name	N Format
1	ZONE_RISK_GROUP_NAME	N VARCHAR2(30)
2	EXERCISE_NUM	N NUMBER(9,0)
3	ZONE_RISK_GP_DESCRIPTION	Y VARCHAR2(127)
4	XMIT_INIT_DATE	Y DATE 7
5	EOC_CLUSTER_ID	Y NUMBER(9,0)
6	EDIT_FLAG	Y VARCHAR2(1)
7	EOC_NAME	Y VARCHAR2(30)

Table Name

ZONE_TYPE

The Zone Type table contains the valid list of zone types that may be used.

Sequence	Name	N Format
1	ZONE_TYPE	N VARCHAR2(5)
2	ZONE_DESCRIPTION	Y VARCHAR2(127)