

BOA: Asbestos Pipe Insulation Removal Robot System -- Phase I

Topical Report

Hagen Schempf
John E. Bares

February 1995

Work Performed Under Contract No.: DE-AC21-93MC30362

U.S. Department of Energy
Office of Environmental Management
Office of Technology Development
Washington, DC

For

U.S. Department of Energy
Office of Fossil Energy
Morgantown Energy Technology Center
Morgantown, West Virginia

By
The Robotics Institute
Pittsburgh, Pennsylvania

MASTER

DISCLAIMER

This report was prepared as an account of work sponsored by an agency of the United States Government. Neither the United States Government nor any agency thereof, nor any of their employees, makes any warranty, express or implied, or assumes any legal liability or responsibility for the accuracy, completeness, or usefulness of any information, apparatus, product, or process disclosed, or represents that its use would not infringe privately owned rights. Reference herein to any specific commercial product, process, or service by trade name, trademark, manufacturer, or otherwise does not necessarily constitute or imply its endorsement, recommendation, or favoring by the United States Government or any agency thereof. The views and opinions of authors expressed herein do not necessarily state or reflect those of the United States Government or any agency thereof.

This report has been reproduced directly from the best available copy.

Available to DOE and DOE contractors from the Office of Scientific and Technical Information, 175 Oak Ridge Turnpike, Oak Ridge, TN 37831; prices available at (615) 576-8401.

Available to the public from the National Technical Information Service, U.S. Department of Commerce, 5285 Port Royal Road, Springfield, VA 22161; phone orders accepted at (703) 487-4650.

DISCLAIMER

Portions of this document may be illegible in electronic image products. Images are produced from the best available original document.

BOA: Asbestos Pipe Insulation Removal Robot System -- Phase I

Topical Report

Hagen Schempf
John E. Bares

Work Performed Under Contract No.: DE-AC21-93MC30362

U.S. Department of Energy
Office of Environmental Management
Office of Technology Development
1000 Independence Avenue
Washington, DC 20585

For

U.S. Department of Energy
Office of Fossil Energy
Morgantown Energy Technology Center
P.O. Box 880
Morgantown, West Virginia 26507-
0880

By
The Robotics Institute
School of Computer Science
Carnegie Mellon University
Pittsburgh, Pennsylvania 15213

February 1995

Abstract

The project described in this report targets the development of a mechanized system for safe, cost-efficient and automated abatement of asbestos containing materials used as pipe insulation. Based on several key design criteria and site visits, a proof-of-concept prototype robot system, dubbed *BOA*, was designed and built, which automatically strips the lagging and insulation from the pipes, and encapsulates them under complete vacuum operation. The system can operate on straight runs of piping in horizontal or vertical orientations. Currently we are limited to four-inch diameter piping without obstacles as well as a somewhat laborious emplacement and removal procedure - restrictions to be alleviated through continued development. *BOA* removed asbestos at a rate of 4-5 ft./h compared to 3 ft./h for manual removal of asbestos with a 3-person crew. The containment and vacuum system on *BOA* was able to achieve the regulatory requirement for airborne fiber emissions of 0.01 fibers/ccm/8-hr. shift. A complete paper¹ has been submitted and accepted for presentation at the next ANS Topical Meeting in Monterey, CA, in February, 1995.

This program consists of two phases. The first phase was completed and a demonstration was given to a review panel, consisting of DoE headquarters and site representatives as well as commercial abatement industry representatives. Based on the technical and programmatic recommendations drafted, presented and discussed during the review meeting, a new plan for the Phase II effort of this project was developed. Phase II will consist of a 26-month effort, with an up-front 4-month site-, market-, cost/benefit and regulatory study before the next *BOA* robot (14 months) is built, and then deployed and demonstrated (3 months) at a DoE site (such as Fernald or Oak Ridge) by the beginning of FY'97.

1. "*BOA: Pipe Asbestos Insulation Removal Robot System*", with J. Bares, E. Mutschler, B. Albrecht, B. Laffitte, American Nuclear Society 6th Topical Meeting on Robotics and Remote Systems, Feb. 5 - 10, 1995, Monterey, CA

Acknowledgments

This work was performed under contract No. DE-AR21-93MC30362 for the Department of Energy, Morgantown Energy Technology Center.

We would like to acknowledge and express our sincerest gratitude to various entities for their constructive support and guidance during the performance of this project:

- **Morgantown Energy Technology Center**

Steve Bossart - Technical Project Officer, Phase I

Vijendra P. Kothari - Technical Project Officer, Phase II

- **DoE ER&WM Robotics Technology Development Program**

Dr. Linton Yarbrough

- **Oak Ridge National Laboratory's Telerobotics Systems Section**

Dr. William Hamel

- **Oak Ridge K-25 D&D Coordinator**

Roy Sheely

- **Fernald Environmental Restoration & Management Co.**

David Tashjian - Asbestos Abatement Coordinator

Don Herman

Brack Hazen

Table of Contents

Abstract	i
Acknowledgments	ii
Table of Contents	iii
List of Figures and Tables	v
1.0 Executive Summary	1
1.1 Background	1
1.2 Programmatic	1
1.3 DoE Site Visits	1
1.4 Robot System Description	2
1.5 Experimental Program	3
1.6 Conclusions and Recommendations	4
1.7 Future Work	5
2.0 Introduction	7
2.1 Background	7
2.2 Robot Concept	7
2.3 Phased Development Program	7
3.0 Project Overview - Phase I	10
3.0.1 Objective	10
3.0.2 Success Criteria	10
3.0.3 Scope of work	10
3.0.4 Task List	10
3.1 Site Visits	12
3.2 Pre-Design Experimentation	15
3.2.1 Cutting Tool Evaluations	15
3.2.2 Compression Testing	15
3.2.3 Compression Mechanism Testing	16
3.3 Robot Design	17
3.3.1 Problem Description	17
3.3.2 System Specifications	17
3.3.2.1 Mechanical	18
3.3.2.2 Operational	18
3.3.2.3 Regulatory	18
3.3.3 Phased Development	18
3.3.4 System Overview	19
3.4 Pre-Testing	30
3.4.1 Robot Functionality Tests	30
3.4.2 Pipe Network Construction	32
3.5 Robot Abatement Experimentation	33
3.5.1 Test-plan description	33
3.5.2 Summary of Results	33
4.0 Phase I Conclusions	37
4.1 Scope of Work	37
4.2 Success Criteria	37
4.3 Overall System Performance	37
4.4 Phase II Motivations	37
5.0 Phase II Recommendations	38
5.1 Technical Recommendations	38

5.1.1 Operations	38
5.1.2 Configuration	39
5.1.3 Design	39
5.2 Programmatic Recommendations	41
6.0 Phase II Follow-on work	43
6.1 Technical Summary - Phase II	43
6.2 Overall Objective	44
6.3 Success Criteria - Phase II	48
6.4 Task List - Phase II	49
6.5 Deliverables	52
7.0 Appendix A: Experimental Apparatus - Photographs	53
8.0 Appendix B: Experimental List	60
Locomotor Functionality Test	62

List of Figures and Tables

Figure 2-1: Operational scenario for the pipe-asbestos insulation removal robot system in a fully robotic and human assistance modes, showing the asbestos removal and packaging actions in progress	8
Figure 3-1: Overall schematic view of the BOA abatement system.....	21
Figure 3-2: Mechanical configuration of the BOA pipe-crawler.....	22
Figure 3-3: Detailed view of the BOA locomotor section, showing the clamping and locomotion systems	23
Figure 3-4: Cross-cut view of the remover section of BOA.....	24
Figure 3-5: Sequence of steps for the BOA removal module.....	25
Figure 3-6: Dimensional views of the BOA robot pipe crawler (dimensions in inches).....	27
Figure 3-7: Overview layout of the movable control rack and the portable operator console and the SPARC development workstation	28
Figure 3-8: Process timeline for a typical abatement cycle (productivity of 2 to 8 feet per hour)	29
Figure 6-1: Operational scenario for the pipe-asbestos insulation removal robot system in a fully robotic and human assistance modes, showing the asbestos removal and packaging actions in progress	45
Figure 6-2: View of the BOA crawler robot developed in Phase I.....	46

List of Acronyms

A

ACM - Asbestos containing materials	7
AL - Aluminum	15

B

BOA - Name of Asbestos Pipe Insulation Removal Robot	i
--	---

C

CALSIL - Calcium Silicate	16
CERCLA - Comprehensive Environmental Response, Compensation and Liability Act	13
CMU - Carnegie Mellon University	11
CO - Contracting Officer	15
CW - Chicken-wire	31

D

DoE - Department of Energy	7
DoE - Department of Energy	8
DOF - Degrees of Freedom.....	12

E

EPA - Environmental Protection Agency	14
ES&H - Environmental Safety and Health	32

F

FEMP - Fernald Environmental Management Project	14
FERMCO - Fernald Environmental Restoration and Management Corporation	12
FRC - Field Robotics Center	11

H

HEPA - High Efficiency Particle	19
---------------------------------------	----

I

I/O - Input/Output	25
--------------------------	----

K

K-25 - Gaseous Diffusion plant at Oak Ridge	14
---	----

L

L&I - Lagging and Insulation	7
------------------------------------	---

M

MAGBLOCK - Magnesium Block	16
METC - Morgantown Energy Technology Center	9

O

O.D. - outside diameter	12
OEM - Original Equipment Manufacturer	35
ORNL - Oak Ridge National Laboratory	16
OSHA - Occupational Safety and Health Administration	16
OU - Operable Unit	14

P

PI - Principal Investigator	14
POC - Point of Contact	14
PPT - Paint and plaster tape	17

R

RI/FS - Remedial Investigation/Feasibility Study	13
ROD - Record of Decision	13
ROI - Return on Investment.....	74

S

SPARC - Scaleable Processor Architecture	19
--	----

T

THK - Mechanical component vendor name.....	53
TIS - Thermal Insulation System	14

X

X-10 - Oak Ridge National Laboratory	14
--	----

1.0 Executive Summary

1.1 Background

Many DoE processing facilities across the country are slated for decontamination and dismantling activities over the next few decades. All of these facilities contain thermal insulation systems (TIS) on walls and ceilings, with most of the TIS accumulated as pipe insulation on steam and process piping. Abatement of these asbestos containing insulation materials is a legally mandated pre-condition for any D&D activities. These TISs not only pose health risks due to airborne fibers which have been identified as a source of various airway, lung and intestinal cancers, but also due to their possible contamination with radioactive process and waste materials. As such, these materials require even more careful treatment during removal, handling and disposal, than regular asbestos. The currently projected abatement and disposal costs for TIS across the DoE processing facility complex, lies in the 10s of millions of dollars, based on manual removal using human workers.

The development of a mechanical means, whether in the form of a hand-tool or teleoperated/semi-autonomous robot system that could increase worker safety and reduce abatement costs while ensuring all federally mandated air quality and related pollution hazard levels was proposed as a viable alternative to human asbestos abatement in 1993 by Carnegie Mellon University. The Department of Energy funded the proposed project via the Morgantown Energy Technology Center, and continues to manage the project for the DoE.

1.2 Programmatic

The BOA project is a two-phase program focussed on the development of an asbestos abatement robot targeting the removal of asbestos-containing pipe insulation and lagging materials. The entire program was broken into a 14-month experimentation and proof-of-concept phase (Phase I) and a 12-month commercial prototype development and demonstration phase (Phase II). The project kicked off in November 1993, and has since completed Phase I (December 1994), and is in the process of kicking off Phase II (January 1995).

Phase I focussed on the development of a proof-of-concept robot system to prove the feasibility of a mechanical removal system and extensive experimentation to understand the behavior of insulation and lagging materials under diverse environmental conditions and handling methods. Site visits were undertaken to better understand the state of TIS in two key DoE sites (Fernald and Oak Ridge), to aid in the development of the first robot system. Experiments on insulation simulant and lagging types were undertaken to explore the proper type and arrangement of cutting, removal, compression and cleaning methods for a completely mechanical abatement system.

Phase II is intended to use Phase I results in order to develop a commercial prototype abatement system that could be used at various DoE sites. Towards that goal, a market study, regulatory evaluation and a cost/benefit analysis will be commissioned to tailor the design and operations of the robot to the most cost-effective pipe-sizes within the DoE site network. Upon completion of the robot development phase, a cold test will be held at CMU on a simulated replica of a real DoE site pipe-network. Upon successful conclusion, the system will be deployed in a DoE site and demonstrated in a real asbestos abatement activity. At that point the industrial partner, RedZone Robotics, Inc. will continue the development, marketing, sales and service of the device to support abatement operations in government and commercial settings.

1.3 DoE Site Visits

The CMU development team visited Fernald and Oak Ridge and inspected process buildings insides for the state, distribution and types of asbestos insulation and cladding materials. The visits served to

calibrate the team to the technical requirements and operational constraints that the robot would have to meet. Both sites were quite different in terms of the prevalent pipe sizes, distribution of piping runs, the state of the insulation and lagging, and the levels of contamination present within each site.

Fernald's main indoor pipe insulation, excluding the outdoor steam-piping, consists mainly of 4 to 6 inch paper and aluminum clad piping runs in various buildings, with approximately 10 to 12 miles of piping in that size range. Some of the insulation is clad with aluminum, but most is mostly paper and plaster-wrap, with some sections reinforced with chicken-wire. All insulation is considered contaminated and as such needs to be carefully handled. All facilities were shut down but the process piping had not been flushed, and hence it was desirable to remove the insulation and lagging without damaging or removing the pipe. It was made clear to us that air-quality and worker safety were the major concerns during any abatement operation, and that all DoE, contractor, local, state and federal EPA and OSHA guidelines would have to be adhered to if robotic abatement was to be considered a viable alternative.

Oak Ridge's K-25 site was personified by the K-23 building that was toured in order to ascertain the scope of the problem at Oak Ridge. Most piping was in the 8 to 12 inch size and purely clad with paper and in somewhat worse shape than at Fernald. Pipe runs were mostly horizontal and widely spaced, with indoor process piping being the main target, since most outdoor piping insulation had either been abated or stabilized with aluminum cladding. We were not able to see more of the K-25 site due to security clearance requirements, but were told of the similarity and larger magnitude of piping in other buildings. Besides the same advice and concerns acquired during the Fernald trip, we also learned that the development of a robotic asbestos abatement device would aid in ensuring a more reliable and consistent/traceable abatement quality than is currently possible with the human approach.

Both sites expressed strong interest in continued collaboration with CMU and offered assistance to review designs, host site visits and to possibly serve as a future demo site for the eventual technology. Dialogs with key people at both sites was maintained during the duration of the program, and pictures obtained from both sites aided in guiding the design and experimentation phases of the proof-of-concept robot development.

1.4 Robot System Description

The proof-of-concept robot system was designed to be a hydraulically powered and remotely controlled self-locomoting mechanical removal system suited for 4-inch diameter piping with up to 1.5 inch thick insulation. The overall system is comprised of an on-pipe system, namely the robot itself, and off-board logistics, consisting of the control rack with the remote control computing, power conditioning and servo-valves, the remote console and video monitor, and the required support logistics in the form of the hydraulic power supply and valving, a HEPA vacuum and an encapsulant/wettant fluid system. A computer workstation was used for software development and system monitoring. All abated insulation was dropped into an attachable glove-bag and disposed off upon filling the bag.

The individual subsystems of the BOA robot system can be further detailed as follows:

Control Rack - The remote control rack consisted of a castered, half-height, 19-inch standard rack-mount console, into which separate compartments were integrated to house the MC68HC11 microprocessor controller and I/O modules, the power conditioning units, the hydraulic valve-controllers, as well as the hydraulic servo-valves. Atop the rack, a video monitor displayed the video fed back from the frontal robot camera.

Tether - The tether connecting to the robot was comprised of all the individual hydraulic control lines, sensor feedback and video cabling, as well as the encapsulant fluid supply line and the HEPA vacuum hose. The hydraulic pump was removed from the system and had supply and return lines connected to the servo-valve block. The HEPA vacuum and encapsulant fluid units were free-standing, with line and

hose bundled into the robot tether.

Control Console - The robot was remotely controllable from a wearable control console, consisting of a tethered vacuum-formed plastic-shell strapped to the operators neck and belly, housing a touch-screen, emergency-stop button and a joystick, and a top-mounted miniature LCD video-monitor for camera feedback from the robot. All subsystems and abatement processes on the robot could be monitored and controlled from the touch-screen.

Robot - The robot itself consists of two main units, namely the locomotor and the remover. The locomotor enables the robot, once clamped onto the pipe, to locomote along the pipe, while the remover is a sealed compartment that contains all the articulated cutting, digging, compression, ejection, sealing and brushing units to properly remove clad insulation from a section of pipe. The vacuum hood used to seal off the remover is transparent for observation purposes and has a frontally attached micro-camera to view the progress of the robot along the pipe.

The locomotor consists of two individually controllable clamping units which can move w.r.t. each other in an inch-worm fashion to allow the entire robot to rigidly clamp onto the bare pipe and locomote along it in a multi-step fashion. Contact pads on the clampers have been rounded and outfitted with hardened and pointy setscrews to ensure proper alignment and non-slip clamping. The locomotor mounts rigidly to the main structural body of the remover.

The remover consists of a set of two circularly articulated c-shaped ring gears, mounted to a base-plate with a central ejection hole, that carry the individual cutting and compression tools needed for abatement. An articulated high-speed abrasive diamond coated cutter wheel residing on a cantilevered deployment plate, and articulated via a hydraulic cylinder is used to create the circumferential cut via digging into the insulation and then using the rotation of the front c-gear it resides on, to achieve a full 360 degree circumferential cut. A set of two paddles with sharp teeth, mounted to each c-gear via a dfpset of hydraulic cylinder actuated plate-systems, allow for digging into the cut insulation and then compressing it off the pipe in a counterrotating movement of both c-gears. Upon completion of the compression, the paddles are hyper-extended, thus ejecting the compressed section of lagging and insulation off the pipe. Several spray-nozzles mounted to the inside faces of each c-gear allow for the application of wetting and sealant to the pipe and open face-cut of insulation remaining on the pipe. Exchanging the cutter blade with a wire-brush allows for the effective cleaning of baked-on insulation and even corroded pipe-surfaces. The unit is sealed to the outside with a plexi-glass vacuum shell which has brush-seals along all its seams and around the insulation and bare pipe, to ensure a good seal between the outside environment and the inside of the remover where all the fibers are generated during the mechanical removal process. An ejection chute mounted to the bottom of the robot allows for the attachment of a glove-bag and the HEPA-vacuum hose.

Through coordination of the individual motions using absolute actuator feedback sensors, the system steps through a sequence of pre-determined motions and performs the abatement process in a programmed and repeatable fashion. The system was tuned to operate at a speed where any type of lagging material and underlying insulation could be successfully abated without human nor computer intervention. This pre-programmed sequence of steps was enabled for each phase of the abatement from the remote console using the touch-screen based menu and interface.

1.5 Experimental Program

An experimental plan for the functional and performance testing of the robot and all its subsystems was drafted, approved and then executed towards the end of the program. Locomotor and remover systems were tested and individual small modifications made in order to increase overall performance or increase the capabilities of the overall system.

The clamping locomotor was tested and found to work quite well, and improvements made to increase its stiffness were found to greatly aid in the accuracy of the device. Special modifications to the contact

pads proved to allow the robot to center itself and walk along pipes in even a vertical orientation without noticeable slippage. The remover was tested and found to work satisfactorily, with certain improvements made to key systems (cutter, paddles) to remove excessive wear and slop due to tolerance stack-up. Sealing of the unit with brush-seals and the applied HEPA-vacuum proved to result in a reliable negative-pressure enclosure within the remover.

Removal experiments on various insulation types (fiberglass and Calcium Silicate) and lagging materials (paper, aluminum and chicken-wire) were carried out and lessons drawn from the results of these experiments. In general it was found that the high-speed cutter worked quite well, but that an additional longitudinal cut was necessary to ensure a reliable removal of the insulation and lagging off the pipe via compression. A deeper cut was needed to fully separate the fiberglass, while the CalSil separated even with a half-depth cut. Wetting and encapsulation worked very well using the embedded nozzles, except for the need to better control the flow-rate of the fluid to avoid excessive runoff. Compression chute size was found to determine the compression forces, while vacuum intake and glove-bag positioning were deemed very successful. Brushing of the pipe via an exchangeable wire-brush head was extremely successful, as it cleaned the pipe to the degree that is specified by law and can be verified via a magnifying lens and the naked eye.

The experimental results collected during this extensive experimental program were invaluable for drafting the list of technical conclusions and recommendations. In summary, the robot was able to abate pipe-insulation at the rate of 4 to 5 feet per hour, under full containment and within legal fiber-count emission levels (< 0.1 fibers/cc), while brushing, wetting and encapsulating the pipe to the legally required cleanliness levels. A total of 32 feet of a variety of insulation and cladding types was successfully removed during the multi-day testing period.

1.6 Conclusions and Recommendations

The experimental testing period proved some of the successfully implemented designs, while highlighting those subsystems that need further improvement or re-design. In addition more general knowledge about the overall abatement approach based on mechanical system performance and material behavior (insulation and lagging), and the deployment process of the system were gained. The conclusions drawn from the results of our experimental testing and the proposed recommendations for each of these areas are detailed below:

Configuration - We would recommend to separate locomotor and remover sections in order to reduce the single-unit weight and to ease deployment using a human worker. The variability of the configuration should allow for the use of the robot system on a variety of pipe diameters through reconfiguration by adaptive means or exchangeable units. Cutting should be ensured to achieve the deepest cut possible and the addition of a longitudinal cut to ease insulation removal. Paddling should be enhanced by stiffening the paddles through double-ended support to also enable the grasping and holding of the cut insulation. The ejection process can be eased and made more reliable by enlarging the chute and using a forced ejection mechanism to 'fling' the insulation into the appended bag. The final cleaning step for the pipe should involve a vigorous circumferential wire-brush system.

System Design - In order to reduce weight and increase system reliability, alternate light-weight materials should be considered (magnesium, composites) and the number of actuated degrees of freedom should be reduced. The entire system should be switched to electrical power, namely a standard 110VAC, 30Amp system. Interfaces for the manual work positioner should be provided in case the robot system is too heavy to deploy manually. The tether system should be simplified and integrated with the fluid and vacuum hosing. Locomotion strokes should be increased and made smoother to reduce cycle time, but without sacrificing system rigidity. The nozzles used to seal the pipe and the insulation should be under flow control to minimize effluent flow and maximize coverage/

saturation. Better static brush-seals along the pipe and insulation are required, as are gaskets and o-rings to seal off mechanical contact areas. A stronger vacuum (between 500 and 1,000 cfm) should be used to achieve the negative pressure requirements and ensure fiber entrapment. Bagging and ejection should be automated and the disposable bags made easy to attach and remove from the robot. The entire robot system should be made waterproof to allow for full immersion cleanup and underwater storage. The overall abatement productivity needs to be boosted, which is achievable through a variety of means such as increased bite-size, reduced cutting time, and coupling several abatement steps - i.e. run them in parallel.

Operations - In order to make the system a more field-worthy operational tool, its applicability will need to be increased. For one we should target the straight runs of piping with all types of insulation and lagging, except for chicken-wire. Insulation thickness variability should be allowable (1 to 3 inch thick), and the system should be usable on various pipe diameters. The overall productivity needs to be brought up to as much as 10 feet per hour (if possible). The deployment of the system should be performed manually if weight allows, but a manual work-positioner could also be used to aid in installation and handling. As before, the system should be self-contained and meet all federal fiber-emissions regulations. Operational support for the system is to be provided by the operator who operates the system and clears obstacles for the robot to be easily emplaced.

In summary one can say that the system performed rather well. Even though unable to demonstrate abatement on vertical piping due to a damaged mechanism, the overall objectives of a high-quality abatement process to at least human quality standard while passing the loose-fiber inspection test, higher abatement throughput and productivity of 3 to 4 feet per hour, while complying with the federally mounted fiber-emissions standard of less than 0.1 fibers/cc, were all met and demonstrated. Improvements to the power system (going from hydraulic to electric), the current mechanical abatement systems (circumferential cutter, paddles, gears) and additions to ease the removal of CalSil insulation simulants (longitudinal cutter) while reducing the compression/removal forces through the addition of a larger chute have all been recommended for the next iteration. Weight and size reduction will also have to be targeted to increase the application domain of the robot and ease the deployment procedures. Increased productivity to up to 10 feet per hour seems achievable by increasing the bite-size of the robot, while the use of a non-contact removal method such as abrasive water-jet might even allow us to abate around hangers and bends (excluding valves and junctions). The next phase will also have to look closely at whether to design a system that can handle a variety of pipe-sizes by having a discretely adjustable mechanism or through the use of exchangeable modules.

1.7 Future Work

Upon conclusion of the Phase I demonstration, the DoE review panel and CMU agreed on the scope of work for Phase II in order to ensure a fieldable and widely useful prototype by the beginning of FY 97. The panel suggested a three-tiered approach in Phase II, with a study, development and deployment period stretching over 22 months, and starting in January 1995. The review panel was to reconvene at the conclusion of each period to evaluate the study results, the proposed and demonstrated prototype robot system, as well as viewing the field test of the system within a DoE site.

The overall program for Phase II and the summary of each activity period can be summarized as follows:

Study - CMU was asked to engage in a study period in conjunction with their industrial partner, RedZone Robotics, Inc., to develop a market study and a cost benefit evaluation subject to a regulatory analysis to guide the design of the robot for cost-effective use within the DoE and potential for commercialization in industrial or commercial nuclear settings. Results from the study were to guide the design specifications as well as manufacturing and operating methods and costs.

The market study was to focus on the DoE sites via Fernald and Oak Ridge, as well as the industrial and commercial nuclear markets. Questions such as market size in demolition and reconstruction, pipe sizes and linear footage, insulation and lagging types and their distribution were all to be used in a cost benefit analysis to determine what sector of the market to target to maximize cost savings within the DoE. Design criteria were to be developed to ensure as economical and manufacturable a design as possible, with easy extensibility to the non-government market sectors. In addition, a regulatory analysis was requested to draft the path for successful acceptance and deployment of the system in accordance with all the DoE, site-contractor and EPA and OSHA regulations that govern asbestos abatement within a DoE site.

Development - The robot prototype is meant to be developed during this period, with the typical design review, fabrication and assembly and experimentation activities and milestones. A pipe network typical of a DoE site was to be constructed at CMU to enable realistic deployments and experimentation during the evaluation period of the prototype. A cold demo on said network will be held at CMU at the conclusion of this period. Should the demo be successful, the system will be readied for a deployment at a selected DoE site.

Field-Test - The deployment of the robot in a real DoE site will require the drafting of all the necessary NEPA information and a detailed field test plan for the specified site. In addition the deployment and DoE site teams will have to be trained in respective areas such as radiation worker and also the operation of the robot once on site. The field test will take place over a few days, with the rest of the time spent setting up, training, and cleanup upon completion of the test and demonstration. Upon conclusion of the project, the robot system hardware and all relevant operations and maintenance documentation will be handed over to the DoE site where the robot has been demonstrated. CMU will also supply copies of all relevant design information to the industrial partner to facilitate the further development and commercialization of the technology. A topical report to be submitted upon concluding the project will summarize all of the Phase II activities and represent the final deliverable from CMU to DoE-METC.

2.0 Introduction

This report is intended to provide a summary of the Phase I activities for the development of *BOA*: Asbestos Pipe-Insulation Removal Robot System, funded under contract # DE-AR21-93MC30362. Towards that purpose, we provide the necessary background in this section to understand the focus and results of the current phase, while motivating the need for continued development.

2.1 Background

The environmental restoration and waste management problem addressed in this project focuses on the abatement of pipe-asbestos insulation inside Department of Energy (DoE) facilities across their entire complex of processing plants. Much of this thermal insulation system is also considered to be radioactively contaminated. The abatement process targets the removal of asbestos pipe insulation from a large range of pipes (typically process or hot-water or steam) with sizes from 4 inches (w/o insulation) to 8 inches in diameter. The objective was to increase abatement productivity, to remove most of the human manpower needed for such a remediation task from the hazardous area, and to ultimately reduce the amount of airborne asbestos fiber emissions. Typical sites that could benefit from such a system after the relatively short development period (2 yrs.) could include building 7 at the Feed Materials Production Center in Fernald, Ohio, and the K-25 uranium enrichment plant at the Oak Ridge Reservation in Oak Ridge, Tennessee.

2.2 Robot Concept

The proposed robot system consists of a dual-robot system (see Figure 2-1), with one mobile boom or platform vehicle supporting a mobile 'pipe-hugging' pipe crawler to remotely remove and package asbestos pipe insulation, thereby completely eliminating the hazard of operator exposure to asbestos. The system will be able to remotely remove asbestos insulation from 4-inch to 8-inch diameter pipes which are currently located in facilities being, or scheduled to be, decommissioned. The developed system consists of an externally-attached pipe-crawler, dubbed *BOA*, which propels along the pipe using a combination of clamping and inching motions, while cutting, compressing and removing the lagging and insulation (L&I). Generation of airborne asbestos fibers is minimized by establishing a negative pressure on the removal module, and coating the stripped pipe and unremoved sections of asbestos around obstacles (valves, hangers, bends, junctions) with a brightly-colored quick-drying thin coat of encapsulant agent to trap any loose fibers. A support-system such as a robotic workplatform working in conjunction with the crawler would carry a continuous bagging device to collect and tie-off sections of stripped asbestos insulation in thick (> 10 mils) plastic 'candy-bags', and leave the bagged insulation pieces on the floor as it progresses, for removal by humans or another automated/teleoperated system. The bags can then be dealt with off-site by processing the asbestos, or disposing of it through burial. Some DoE sites require multiple bagging which will have to be accomplished in a sequence of single-bagging steps. The remaining pipe can then be cut as in a normal decommissioning task. We also have visions to make the system modular to allow for operator-assisted abatement (see Figure 2-1) in the DoE complex.

2.3 Phased Development Program

Our principal objective for Phase I (12 months duration) was to develop a crawler to strip insulation and lagging from 4 inch diameter pipes covered with 1 to 3 inches thick asbestos insulation or ACM (asbestos containing material), be it contaminated or not, with our scope initially limited to work only on straight runs of pipe. We have completed all the prescribed tasks and have developed a prototype robot crawler and control console to better study and understand the issues involved in the development of a complete robotic abatement system. The experimental results gathered during this period on a fiberglass insulated mock-up pipe network, clearly indicate the strengths and weaknesses of the current design, while identifying the complexities and complications in a real abatement process. The details of the individual task activities and the results and recommendations from this first phase are further detailed in the sections to follow.

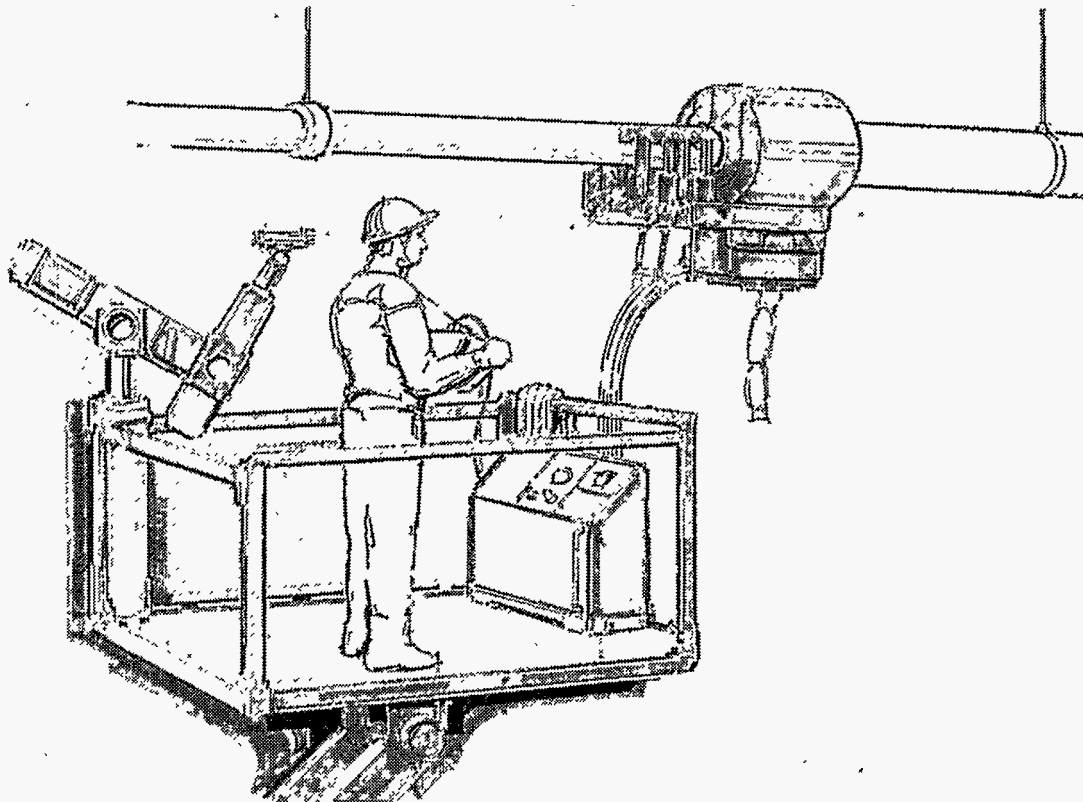
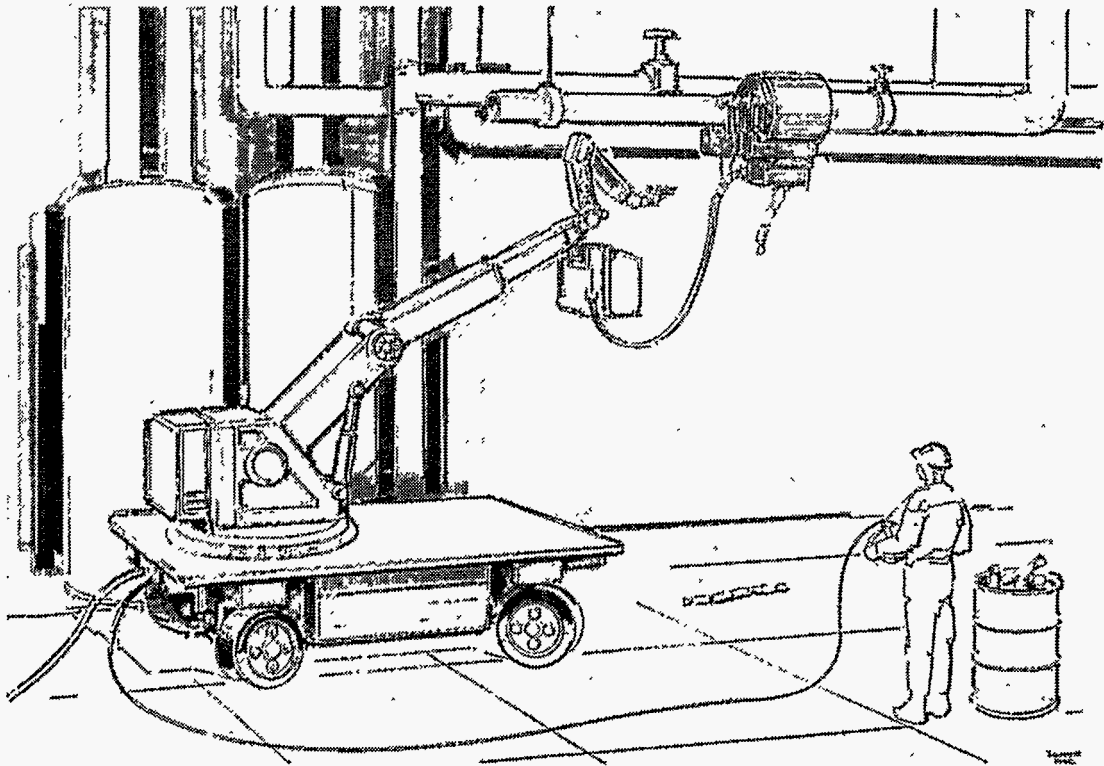

Figure 2-1 : Operational scenario for the pipe-asbestos insulation removal robot system in a fully robotic and human assistance modes, showing the asbestos removal and packaging actions in progress

The remainder of the topical report is organized as follows:

Chapter 3: Phase I Overview details the activities during the Phase I effort as described by the task list in the METC contract. We describe the individual tasks such as the design of the robot, its procurement and fabrication, the preliminary tests to be performed as well as the extensive insulation abatement experiments we intend to perform as part of this phase.

Chapter 4: Phase I Conclusions describes the conclusions drawn from the experimental testing performed at the end of the program. These conclusions are all mainly targeted to benefit the follow-on phase in terms of overall design, compliance with regulations and handling the realities of insulation abatement within the DoE complex.

Chapter 5: Phase II Recommendations provides a more detailed summary and description of the proposed scope of work based on the Phase I experimental results.

Chapter 6: Phase II Follow-on Work summarizes the scope and details of the proposed work to build on Phase I and improve the system and tailor it to the DoE site needs.

Chapter 7: Appendices collects a set of digitized prototype pictures, as well as a sample of one of the many experimental test plans that were used to evaluate the robot's performance.

3.0 Project Overview - Phase I

3.0.1 Objective

The objective of the first project phase was to develop and test a prototype abatement pipe crawler to learn more about this complex abatement task. As part of that objective, we identified a variety of experimental, design, procurement, fabrication, and demonstration tasks to provide guidelines for the development of a more complete robot system in the second Phase of the program. The end-of-phase demonstration would be on a realistic mock-up of a fiberglass-insulated pipe such as one would find at Building 7 in Fernald, OH, or in the K-25 plant in Oak Ridge, TN. The goal of this program was to provide for a comprehensive solution for the abatement of hazardous asbestos insulation, including the removal, sealing, packaging, and delivery for easy processing or disposal. The system would allow for commercially available systems on-site at DoE facilities removing asbestos within one to two years after the conclusion of the two-phase development program.

3.0.2 Success Criteria

The prototype would be considered a success, if at the conclusion of Phase I we could demonstrate, that the crawler is indeed able to easily attach/detach itself from target pipes, and locomote effectively on different pipe surfaces (wet, dry, etc.), while removing insulation. The success was to be measured by how effectively asbestos insulation could be removed in the presence of all the cladding-types we found to be present within DoE facilities; i.e. paint, plaster-tape, wire-mesh, aluminum-cladding, bands, etc. Furthermore, the crawler had to be able to prove that obstacles such as pipe-hangers could effectively be sealed in place by the crawler for later human removal, leaving only a minimal amount of unstripped insulation behind. A measurement of the crawler's ability to remove linear footage of asbestos insulation per hour was designated to be the ultimate performance measure, and we tasked ourselves to demonstrate that it could at least match the productivity of a human worker performing the same task.

3.0.3 Scope of work

During Phase I, applied engineering design and experimentation efforts were focussed on cutting methods, optimal frame geometry and location of drive/removal/sealant modules to enable obstacle negotiation (hangers), locomotor actuator and actuated frame geometry, and miniaturized component packaging. Experimentation with various insulation-removal methods such as slicing, cutting and peeling were initially prototyped, in order to better understand the physical processes and issues involved in insulation-removal while driving along a pipe. The task of engineering detailing for the structural frame and locomotor frame geometries, locomotor actuators, insulation slicing/peeling/cutting system, sealant-module layout, and operator control-box design and layout were all part of this first phase. Procurement, fabrication, assembly, testing, and demonstration concluded this phase. This first phase was considered heaviest on applied and experimental engineering groundwork and design, with a moderate effort in engineering detailing.

3.0.4 Task List

During the performance of this first phase, we engaged in several tasks which are further detailed in this section. The overall task descriptions are given below:

- **DOE Site Assessment**

We travelled to Fernald and Oak Ridge to better study the on-site problems at Building 7 and K-25, respectively. A set of summary reports about these fact-finding trips were generated and submitted to METC, and are summarized in Section 3.1.

- **Pre-Design Experimentation**

The prototyping and testing of various cutting and removal methods was the most important activity in this phase. We tested many alternative ways to cut and remove lagging and

insulation from pipes, with results that clearly steered our prototype robot design reflects. A summary of the pre-design experimentation results is given in Section 3.2.

- **Detailed Design**

During the detailed design phase we included all of our practical experience gained during the experimental phase into the design of the locomotion and removal module. The results of the design were presented to a DoE review team at the end of May, after which we were given the approval to proceed. A detailed design presentation document was generated and has also been submitted to METC. Highlights from this document are given in Section 3.3.

- **Fabrication and Integration**

The assembly and integration was performed and the system was readied for the exhaustive testing period on the pipe-network we installed at the Field Robotics Center (FRC). A summary of the fabrication and integration phase is given in Section 3.4.

- **Pre-Testing**

During this activity we performed all of the functional evaluations of the robot system and subsystems. The testing and burn-in phase was guided by the experimental plan which was developed by Carnegie Mellon University (CMU) and delivered to METC for comment in the month of September. A summary of the results of these tests is included in Section 3.4.

- **Abatement Experimentation**

The complete abatement experiments were performed mainly in the months of September and October 1994 and used to gather data of the overall performance of the prototype system and provide useful guidelines for the next robot version. A complete set of experimental test plans and the derived results is provided in Section 3.5.

3.1 Site Visits

The principal investigators from CMU took two separate trips to Fernald and Oak Ridge's target facilities where the abatement robot was thought to be of future use. For brevity sake, only abbreviated summaries from these two trips are included below. The information gathered during these visits was priceless, since it provided the needed background and guidance to focus the phased development specifications for the robot system.

• Fernald Environmental Restoration and Management Corporation

Fernald's main indoor pipe insulation, excluding the outdoor steam-piping, consists mainly of 4 to 6 inch paper and aluminum clad piping runs in various buildings, with approximately 10 to 12 miles of piping in that size range. Some of the insulation is clad with aluminum, but most is mostly paper and plaster-wrap, with some sections reinforced with chicken-wire. All insulation is considered contaminated and as such needs to be carefully handled. All facilities were shut down but the process piping had not been flushed, and hence it was desirable to remove the insulation and lagging without damaging or removing the pipe. It was made clear to us that air-quality and worker safety were the major concerns during any abatement operation, and that all DoE, contractor, local, state and federal EPA and OSHA guidelines would have to be adhered to if robotic abatement was to be considered a viable alternative.

Technical issues that were discussed can be summarized as follows:

- Process lines rather than steam lines were suggested as targets for the system. The implication is that only radioactively contaminated asbestos will need to be abated.
- Inside process lines were the most desirable target as outside lines are in good condition and there are comparatively few feet of outside steam piping due to the concentration of buildings on the 100 acre site.
- Prevalent pipe diameters range from 2 to 18 inches, or 5 to 22 inches including insulation. Insulation thicknesses were said to vary, but no more detailed data was available.
- The most common and desirable range of piping was around 4 inches nominal pipe OD, with 1.5 to 3 inches of insulation (i.e., overall OD ranging from 7.5 to 10.5 inches).
- Typical 4" pipe has runs of 25 feet between bolted flanges, with most of those flange connections remaining uninsulated, while other connections seemed welded and were insulated (about a 50%/50% split).
- Clearances to surrounding obstacles and other piping and supports makes outside pipe travel and removal extremely difficult. An orientable removal and bagging subsystem will be needed to negotiate varying location and sizes of obstacles.
- Removal of insulation around hangers without human assistance seems extremely desirable and key to the attractiveness of the system. Valves and junctions/bends however, could require the assistance of human abatement workers.
- About 50% of the internal lines are aluminum clad; of these, 50% have straps, while the other 50% have sheet metal screws along the longitudinal seam of the cladding.
- Removal of cladding and insulation in chunks without separation is acceptable, while wetting and encapsulation are a must.
- Chicken wire exists within the DoE, but it is also rare and its location many times unknown. Stainless cladding was not encountered.
- Removal of hangers was deemed a sticky issue, due to the creation of large unsupported loads (pipes). Most workers seem to cut pipe length between hangers and leave a minimum pipe length supported by the hanger for later removal (assuming all the TIS has been removed). Requiring BOA to also remove hangers seems an unrealistic scenario.

- Removal costs (without adding transport and disposal costs which are known to be the largest portion of the abatement costs) are somewhat insensitive to pipe diameter, but very sensitive to contamination levels. No data was available for the storage, transport and disposal costs. FERMCO removal costs seemed very low compared to industrial abatement and other DoE abatement costs we were quoted which lay in the \$100 to \$200 per linear foot range!
- Removal of the insulation fibers that are attached to the outside of the pipe due to corrosion effects is currently the toughest part of the removal, as it requires workers to use scrapers and knives to remove the scale. It was likened to removing corrosion from pipes (using a steel brushing or sand-paper)
- If FERMCO is to use the BOA machine, it will have to meet EPA regulations. Containment regulations are a key!
- Fiber release has to be well controlled, and the system will be held to all federal, state, local and company regulations.
- The system should be deployable by a human operator and allow for human-assisted operation. Totally self-operating and unassisted operation seems unrealistic, especially as most pipes are well within reach of a person and require little or no scaffolding. This would also allow the human to re-position the system and replace filled bags.
- Using calcium silicate half-shells and encapsulant to simulate sticking insulation was suggested as the best comparable experimental insulation, but was not deemed very representative since the insulation we will be removing is extremely friable and hence does not have a block-like nature.
- The biggest win of the system would be if it can contain airborne fibers and thus avoid the construction of containment sections, reduce the amount of scaffolding, increase the linear working efficiency which now lies at no more than 65 minutes per 3 foot pipe section, and be adaptable to as large a pipe range as possible. The pipe must be cleaned at least as well as with current human methods.
- Fernald will issue to the EPA their draft Record of Decision (ROD) for asbestos abatement at FEMP by August '94, which will be expected to be signed by early 1995. The final ROD will be submitted before 1997, and the actual abatement phase is scheduled to start at that time. No estimates were given as to how long it would take to complete the entire abatement job. As the treatability study (component of the ROD) is completed, this data and the expected utility of BOA will become apparent¹.
- It was recommended to us that we acquire more CERCLA and EPA/OSHA documents to be knowledgeable about asbestos abatement regulations. A contact to an EPA asbestos expert within the EPA has since been established.

• Oak Ridge National Laboratory

Oak Ridge's K-25 site was personified by the K-23 building that was toured in order to ascertain the scope of the problem at Oak Ridge. Most piping was in the 8 to 12 inch size and purely clad with paper and in somewhat worse shape than at Fernald. Pipe runs were mostly horizontal and widely spaced, with indoor process piping being the main target, since most outdoor piping insulation had either been abated or stabilized with aluminum cladding. We were not able to see more of the K-25 site due to security clearance requirements, but were told of the similarity and larger magnitude of piping in other buildings. Besides the same advice and concerns acquired during the Fernald trip, we also learned that the development of a robotic asbestos abatement device would aid in ensuring a more reliable and

1. The treatability study is part of the CERCLA Remedial Investigation/Feasibility Study (RI/FS) process (product of a consulting engineering firm), which results in a recommended approach for cleanup. The Record of Decision (ROD) (product of DOE contractor) takes the recommended action and documents the selected cleanup approach.

consistent/traceable abatement quality than is currently possible with the human approach.

In summary, here are the key technical issues that were addressed:

- The robot system will need to either just remove insulation (and hence travel on the outside of the pipe), or remove piping and insulation (thus potentially traveling on the inside of the pipe). The basic choice is between a decommissioning and a maintenance asbestos abatement system.
- Prevalent pipe sizes range from 6 to 8 inches, or 10 to 12 inches with insulation.
- Pure steam lines rather than process lines were suggested as targets for the system. The implication is that no radioactively or classified contaminated asbestos will need to be abated.
- Clearances to surrounding obstacles and other piping and supports makes external pipe travel and removal extremely difficult. An orientable removal and bagging subsystem will be needed to negotiate varying locations and sizes of obstacles.
- Removal of insulation around hangers without human assistance seems extremely desirable and key to the attractiveness of the system. Valves and junctions/bends however, could require the assistance of human abatement workers.
- Insulation on the inside of buildings rather than the outside, is the main area of interest at K-25 and X-10 (K-25 is the gaseous diffusion plant and X-10 is the National Laboratory). Insulation on outside piping is aluminum clad, and of lower priority.
- Removal of cladding and insulation in chunks without separation is acceptable, while wetting and encapsulation are a must.
- Most internal piping insulation has none or very little aluminum cladding, but certainly aluminum straps. Chicken wire exists but is also rare and its location unknown. Stainless cladding was not encountered.
- Fiber release has to be well controlled and the system will be held to all federal, state, local and company regulations.
- The system should be deployable by a human operator and allow for human-assisted operation.
- Using calcium silicate half-shells and encapsulant to simulate sticking insulation was suggested as the best comparable experimental insulation.

3.2 Pre-Design Experimentation

As part of our up-front experimental phase, we engaged in a variety of subtasks to generate hands-on empirical data to better guide our design process. The activities under this task can be summarized as follows:

- Cutting Tool Evaluations
- Compression Testing
- Compression Mechanism Testing

Each of these subtasks involved a variety of activities which are summarized below according to subtask:

3.2.1 Cutting Tool Evaluations

We procured a set of diamond-tipped saws and routing bits and performed a variety of lagging removal tests. The results are listed below:

- Regular milling-endbits are satisfactory for cutting through aluminum (AL) lagging and steel bands, but were absolutely hopeless and caused tangling and complete system jamming when cutting chicken-wire. We are convinced that no cutter with serrated, nor sharp long edges should be used.
- Router bits coated with diamond fragments were successful in cutting through all forms of lagging, bands and chicken wire, albeit at a slow pace and causing extreme heat build-up on the tool and requiring substantial feeding force for a successful abrasion pressure.
- Simple round disks with sharp and diamond-coated edges were tested and found to have excellent cutting performance with any form of cladding - including stainless steel. Further, they can be run in forward and reverse with no difference in cutting efficiency. This is currently our preferred cutting method.

We hence decided to incorporate circular cutting blades into our system design. We also measured cutting-power measurements using a hand-held grinder outfitted with the abrasive cutting wheel. It was interesting to note that it took about 250 Watts to idle the cutter blade, while power jumped to 550 Watts during the dive-in and to about 450 Watts during the cutting of straps or thicker lagging sections. This experiment helped to define the cutter specifications including the need for a coarser grit of synthetic diamond or carbide on the cutting blade.

3.2.2 Compression Testing

We developed a linear compression test-jig with AL sheathing and fiberglass insulation and installed it in a materials testing laboratory at CMU. We found the following results:

- For sections of 24-inch long aluminum lagging (0.030 in. thick) and insulation (1.5 inches thick), we achieved 5:1 compression ratios with as little as 500 pounds of compressive force, while a compression ratio of 10:1 was possible with up to 4,000 lbs of compressive force.
- Once compressed, the material tended to relax back by about 30% of its compressed size, due to the compliance of the fiberglass insulation. We believe that in real situations the friable aspect of ACM will result in much less relaxation. This has an effect on sizing the packaging module on the crawler, and the bags to hold the removed insulation.

We hence added a compression step to the removal process due to the inherent benefits in waste-size reduction, easier waste handling, and reduction in airborne fiber generation.

We studied different types of insulation materials ranging in consistency from cardboard to a hard-packed silicate material, based on additional information from insulation manufacturers and installers and from the two DoE sites (Fernald and ORNL) that we visited. Upon further questioning, it became

clear that it is impossible to guarantee that all insulation is *friable*¹ or compliant like fiberglass or cardboard. Even though the majority of the insulation we expect to find will have such compressible characteristics, we were warned that these properties may not be evenly distributed, and that some sections of piping may have been re-insulated with newer insulation materials available at the time.

These newer materials were identified as CALSIL and MAGBLOCK² and they have the consistency of very hard styrofoam. The implications of these materials being interspersed in unknown locations and with unknown frequency along pipes in all these facilities, posed an even greater design challenge to the removal system than previously expected.

3.2.3 Compression Mechanism Testing

We acquired two pipe-bevelling mechanisms used in the pipeline construction industry, due to their ingenious pipe-encircling mechanism which we intend to integrate into our final removal system. The purpose of this purchase, was to use the appropriate components in an experimental setup to test the lagging and insulation compression theories on pipes while measuring forces and rates. This experimental activity was to feed results into the continuing design effort for the final mechanism.

Interesting results highlighted the need for lead-in sections and the tendency of the lagging to spread and 'accordion' along the corrugation lines during compression, while the fiberglass insulation tended to generate large compression forces, and return to its normal volume once un-compressed. It was interesting to realize the deflection characteristics of the gears and structure under compressive loads leading to a re-evaluation of material selection and bearing supports for the paddles. Paddle cross-section was increased and the ability to add lead-in sections was added. The paddles and jigs were also modified to allow for compression experiments with an opening at one end to simulate the ejection hole.

1. *friable* is defined as turning to dust as soon as it is touched and slightly compressed

2. CALSIL and MAGBLOCK are trade-names and stand for Calcium-Silicate and Magnesium-aggregate block

3.3 Robot Design

The robot design activity can best be described by providing a summary of the design review meeting in May 1994:

- **Problem Description**
- **System Specifications**
- **Phased Development**
- **System Overview**

Each of these topics is covered in detail in the following sections.

3.3.1 Problem Description

The description of the problem that we would have to deal with, based on the site-visits, yielded a structured description of the issues we would need to keep in mind. The main descriptors of pipe-insulation we identified as:

- **Material Types**

The material types typically found in insulation material consist of the insulation material itself and the covering/lagging material that protects the insulation against the elements and gives it structural integrity. These two are referred to as lagging and insulation (L&I).

The insulation material is typically made of asbestos-containing materials (ACM), such as asbestos(rock)-wool, cardboard or fibrous filler, or CALSIL or Mag-block. Lagging materials are typically found to be paint or plaster tape (PPT), aluminum sheathing (with clamps or screws), chicken-wire (on large or repaired sections), and sometimes even stainless steel sheathing (which we do not address in this scope of work, though).

- **State of L&I**

The state of the ACM ranges from '*friable*' to woolen and possibly even solid with high potential of being 'baked' onto the pipe, while the lagging ranges from structurally sound (aluminum sheet and chicken wire) to brittle (PPT).

- **Distribution of L&I Types and States**

More importantly it was determined that it is very likely that the distribution of these various L&I types and states is present across all facilities, and that the actual L&I on any given pipe is likely to be unknown. Any effective robot system would hence have to be able to deal with all these possible states.

- **Obstacles**

Along any run of piping it was determined that we would encounter obstacles such as pipe hangers, valves and diameter changes, junctions and bends, and crossing/neighborhood pipe runs.

- **Access**

Access to pipe runs could be difficult due to large and hidden reaches, and occluding pipes (mazes).

- **Operations**

As part of the operational certification for the system, issues such as acceptance and certification by agencies such as EPA and OSHA, as well as the strict air monitoring requirements will have to be considered if the system is to be widely used.

3.3.2 System Specifications

Based on all the information gathered during the initial months of the project, we developed a set of specifications that we wanted the robot to be able to comply with at the end of the full program. We split those specifications into mechanical, operational and regulatory categories. A tabular form of the desirable system specifications is given below. After further review and discussion, the key attributes

will mainly be in the area of regulatory compliance with existing regulations imposed by OSHA and EPA (local, state and federal).

3.3.2.1 Mechanical

- Pipe Size (nom. O.D. [in]).....4 - 8
- Insulation Thickness [in]1 - 2
- LaggingPaint/Plaster, Chicken-wire, Aluminum Sheet, Clamp/Screw
- Insulation TypesPowder to Mag-block
- Loose Fiber EntrapmentWetting/Encapsulation
- Fiber Flyings ReductionVacuum/Air Flow
- L&I PackagingYes
- Weight [lbs].....Minimum
- SuppliesHydraulics, Electric, Air, Encapsulant, Poly-bags
- L&I Bagging.....6-mil poly-bags; continuous stream
- Waste Stream.....Mixed ACM & Lagging
- CleanupWash-down or Immersion

3.3.2.2 Operational

- ApplicabilityVarious pipe sizes and self-starting
- Deployment.....Manual and Remote
- Exceptions.....Hangers, valves, bends, junctions
- Containment No full-containment enclosures
- Manual Touch-up.....+/- 6' around obstacles
- L&I Removal Speed.....2 to 8 feet/hr.
- Operational ModeManual & Automatic

3.3.2.3 Regulatory

- Fiber Emissionsaccording to EPA & OSHA & Contractor
- Wetting..... Yes, internally
- EncapsulationYes
- Air Monitoringif required

3.3.3 Phased Development

After reviewing the overall requirements, we split the program into a two-phase program, where the initial phase was to be a proof of concept to answer some of the more difficult questions about the abatement process itself, without needing to develop a fully integrated and field-worthy prototype. The overall development plan then proposed that the overall system requirements be split among the first two phases as shown in the table below:

	GOAL	RESULTS
Insulated piping	4.5" OD; 1-2" thick	full-depth cut hard
Lagging	all, except stainless	OK - long. cut needed
Pipe cleanliness	brush demo (off robot)	OK
In-situ bagging	no	yes, simple bag
Waste compaction	yes (4:1 estimate)	no, not needed with chute
Removal around obstacles	no, only face-cut spray	OK
Locomotion past obstacles	no	no
Insulation wetting	100%	yes (5% absorption)
Pipe encapsulation	100%	yes
Operational mode	Self-propelled	yes
	Cleared pipe to start	yes (15" required)
	Manually emplaced	yes (117 lbs)
Full emission containment	0.010 fibers/ccm/8-hours	0.0103 fibers/ccm/8-hour
L&I removal in any orientation	yes	OK - horizontal
		failed - vertical
Abatement productivity	2 to 8 ft./hr	4.7 ft./hr
Self-cleaning	no	no

Table 3-1 : BOA system performance capabilities

3.3.4 System Overview

A diagram of the overall system is shown in Figure 3-1. The overall configuration consists of an off-board system of support logistics that supply power to and receive data from the abatement robot mounted to the pipe. The abatement robot rides the pipe while systems and video feedback are relayed via tether to the support systems on the ground. The entire robot is hydraulically powered (at least in this prototype version), with only the electric cutter, front-mounted video-camera and all feedback sensors being electric. The off-board systems comprise the hydraulic power and control system, the wetting/encapsulant system, as well as the HEPA-vacuum filter unit. The entire hydraulic valving and driver sections are mounted into an off-board electronic rack, together with the microprocessor controller, video display and recording unit. The operator controls and monitors the system using a portable console with a touch-screen, joystick and emergency kill switch. A more elaborate monitoring and display system is coupled to a Sun SPARC station, which is only used for development purposes and the evaluation of appropriate graphical user interfaces. A set of photographs of the prototype system are included in Appendix A: Experimental Apparatus - Photographs on page 53.

- **Mechanical configuration**

The overall design of the pipe-crawler system is shown in Figure 3-2. Notice that the crawler consists of several subsystems, two of which make up its main body, namely the locomotor and the remover. The sealant hood or vacuum shell is used to contain all fluids and fiber flyings during the abatement operation. The video camera is housed in a sealed container on the front of the robot, providing the operator with an along-the-pipe view. The current system has been designed to strip 8 inch OD L&I insulation from 4-inch nominal O.D. steel piping.

- **Locomotor**

The robot locomotes along the pipe using an inch-worm approach (see Figure 3-3). Two separate clamping modules use three-point shoe-clamps to attach to the pipe, and by alternating the clamping and release functions, the two separate clamping modules can be moved with respect to each other using an actuator. The locomotor is then attached to the remover section.

- **Remover - Overall**

The remover section shown in Figure 3-4 consists of two separately actuated c-gears (open-cut ring-gears) on either end, supporting the paddling, cutting and spraying systems. The c-gears are supported by t-rails in the frame and are actuated using a hydraulic gear-pump/reducer combination via a chain-drive. A compression paddle is affixed to each c-gear. In addition, a circular cutter is mounted to the forward c-gear. The c-gears are used to synchronously turn or counterrotate depending on the desired function to be accomplished. Feedback is obtained using an environmentally-housed multi-turn pot.

The remover performs several sequential functions which are shown in Figure 3-5, and consist of start, cut, plunge, compress and re-align. The starting phase allows the robot to locomote and clamp itself into place for the beginning of the abatement process. Wetting fluid is sprayed on the 6-inch section of L&I and the HEPA vacuum is started. The cutting operation involves the actuation of a short-stroke hydraulic cylinder to plunge an electric cutter motor with a diamond-grit blade into the L&I, after which the c-gear holding the cutter is turned in a full 360 degree rotation to provide a full circumferential cut. The cutter is retracted and the c-gear aligned to allow for the actuation of the 4-bar paddle-linkage mechanism to plunge two serrated compression paddles into the top of the L&I section. Since each paddle rides on a separate c-gear, compression is possible by counterrotating the two gears to the point where the L&I section has been compressed to within the size of the chute-opening. Both paddle linkage mechanisms are then hyper-extended to allow for the ejection of the compressed L&I-brick. The paddles are then retracted and the c-gears re-aligned. Encapsulant fluid is then pumped and sprayed onto the exposed pipe by counterrotating the rear c-gear to allow full circular coverage. The cutter has its own dedicated wetting spray nozzle to minimize the release of any airborne fiber flyings. After the encapsulant has been sprayed, and while it is still wet, the robot walks forward about 6 inches to begin the process anew. The entire cycle of the removal and the particulars of the cycle-steps are detailed later in this section.

- **Overall dimensions**

The overall dimensions for the robot crawler are given in Figure 3-6.

- **Off-board Logistics**

The off-board logistics consist mainly of the control rack, the remote console, the HEPA filter, the wettant/encapsulant system and the hydraulic power supply.

The control rack shown in Figure 3-7 shows the integrated components to operate the complete robot system, except for the relays to turn the HEPA filter and the fluid supplies on and off controls. We also provided a portable control console with a built-in touch-screen and a kill-button and joystick. In addition an off-board SPARC workstation is used to make software and interface code developments and port them to the console and microprocessors for testing.

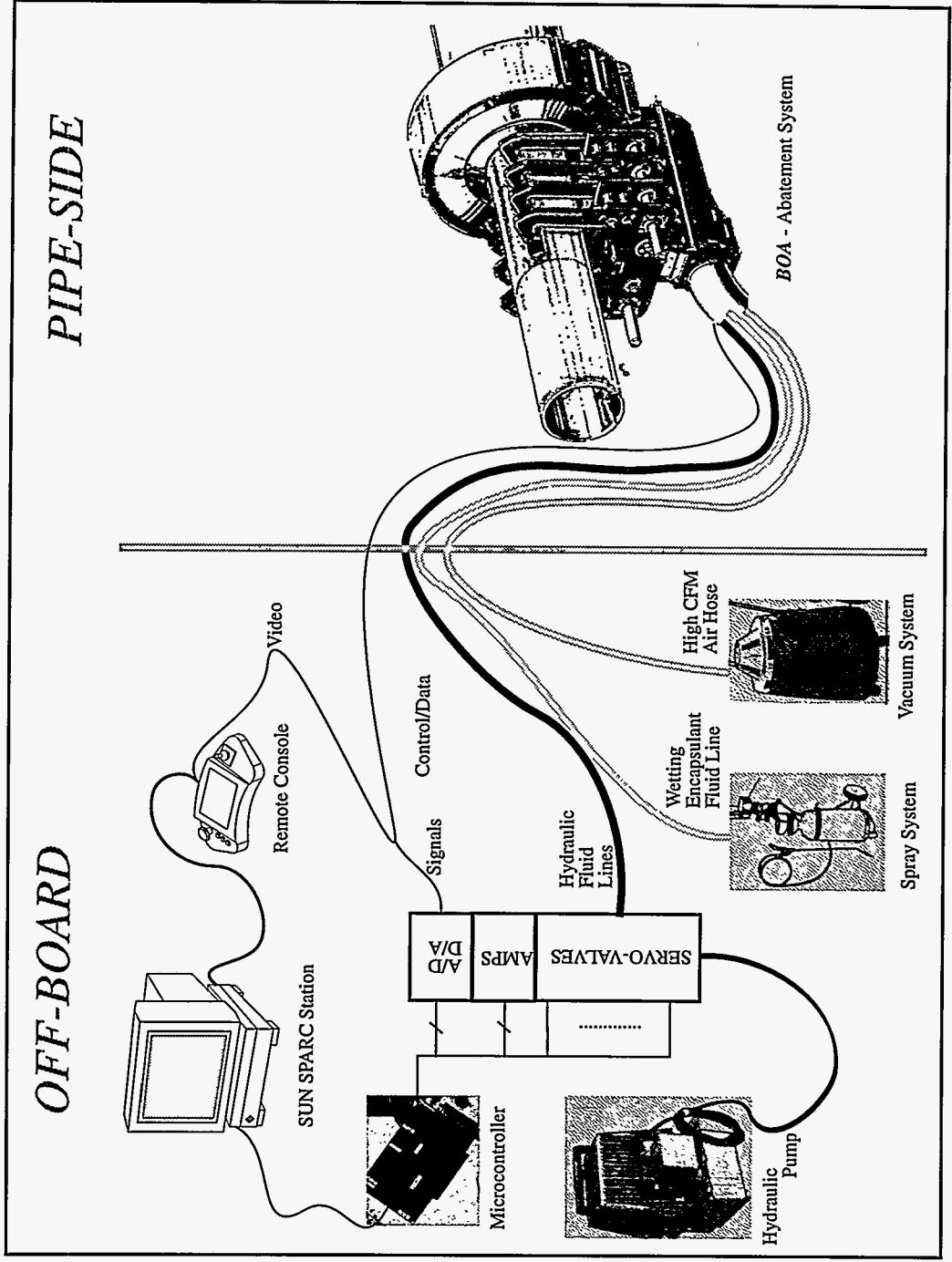

Figure 3-1: Overall schematic view of the BOA abatement system

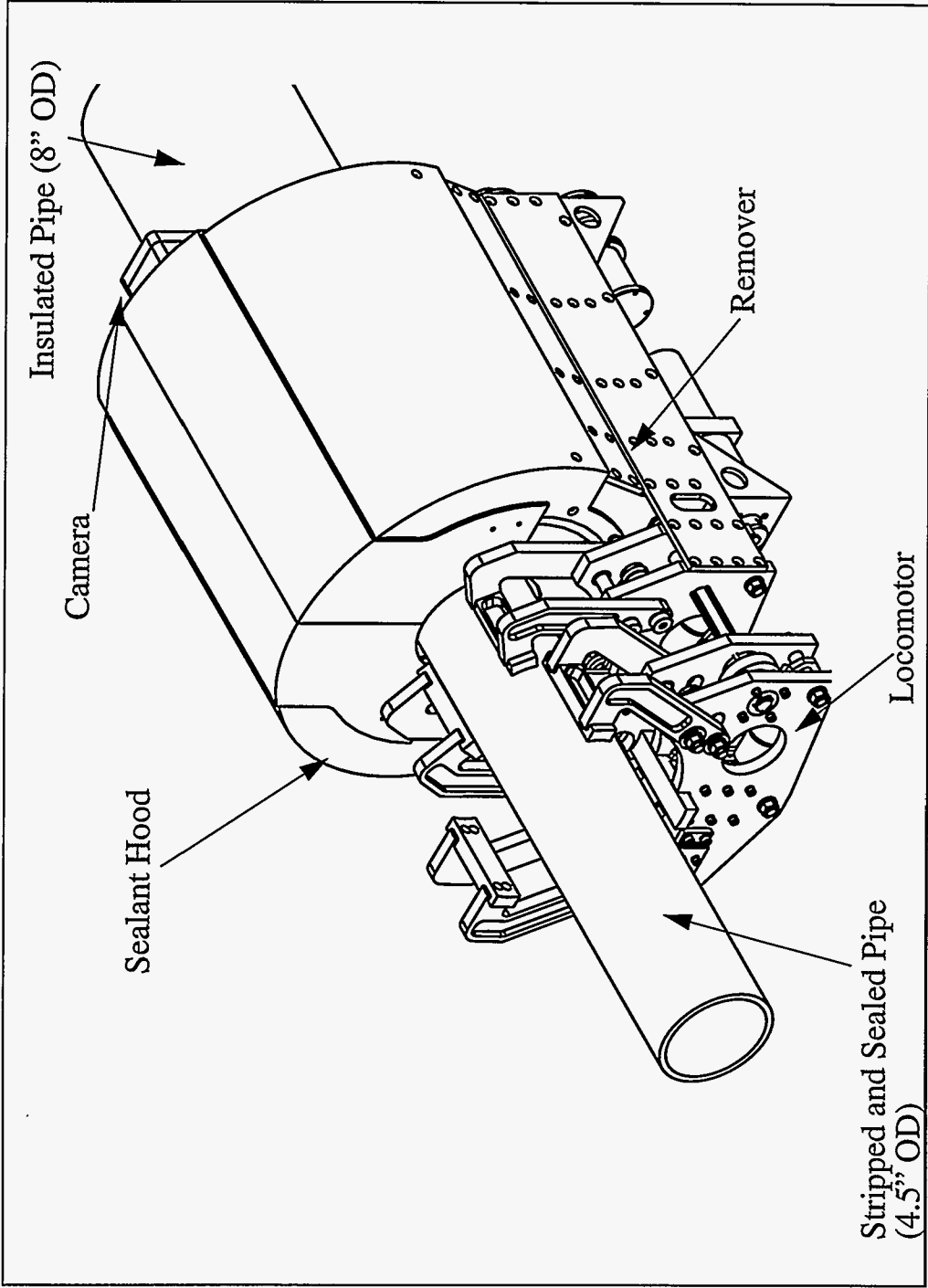

Figure 3-2 : Mechanical configuration of the BOA pipe-crawler

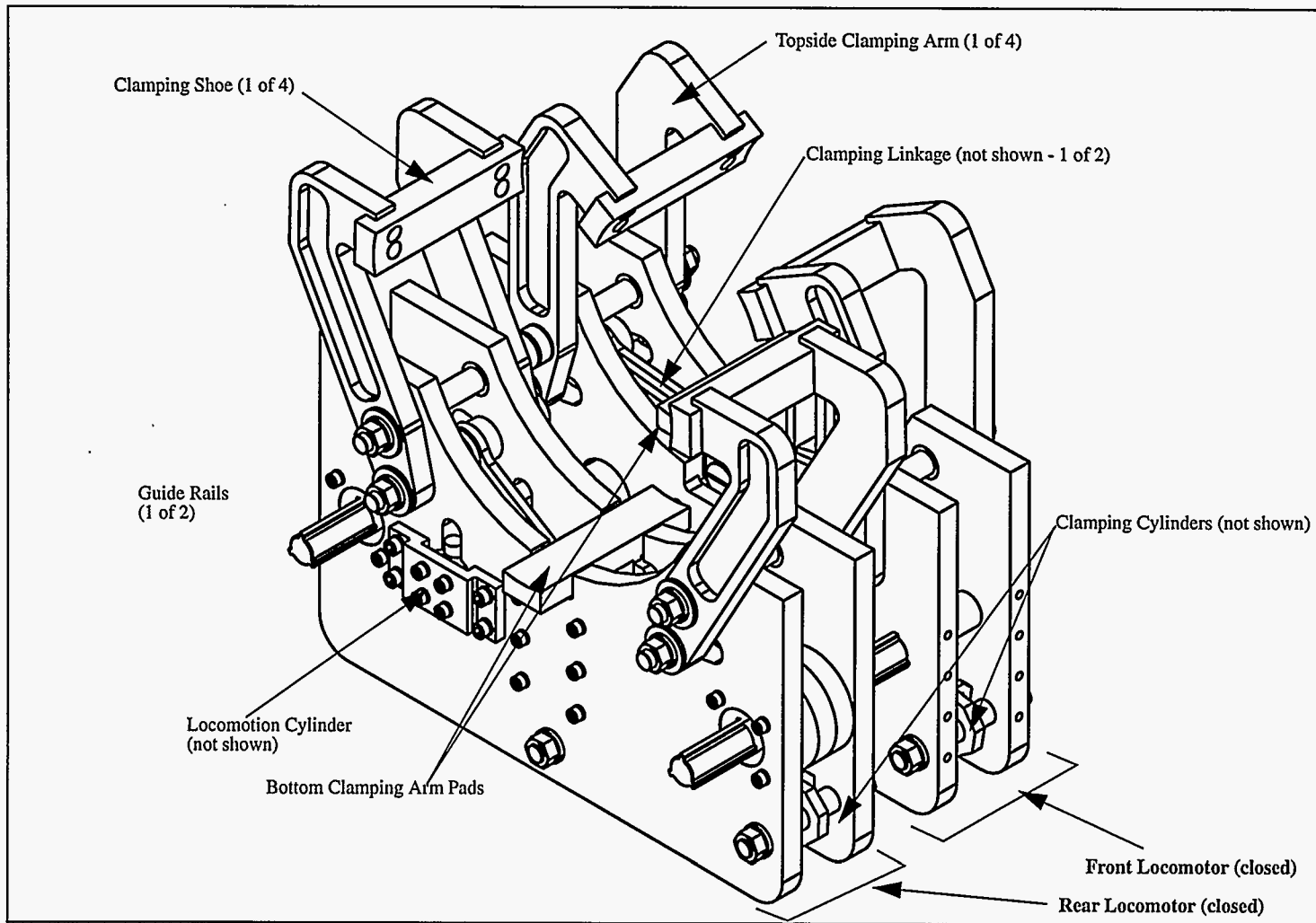

Figure 3-3 : Detailed view of the *BOA* locomotor section, showing the clamping and locomotion systems

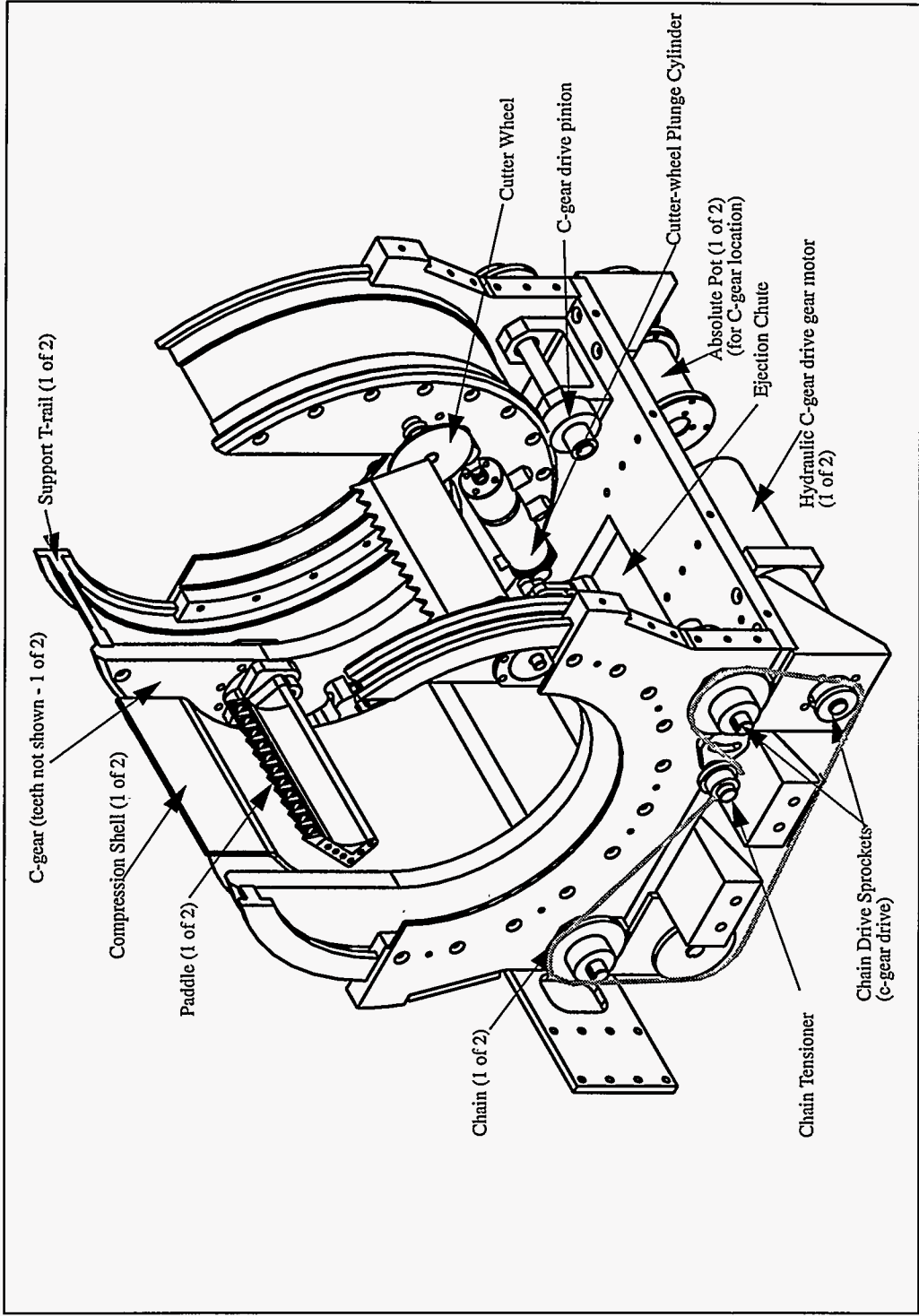

Figure 3-4 : Cross-cut view of the remover section of BOA

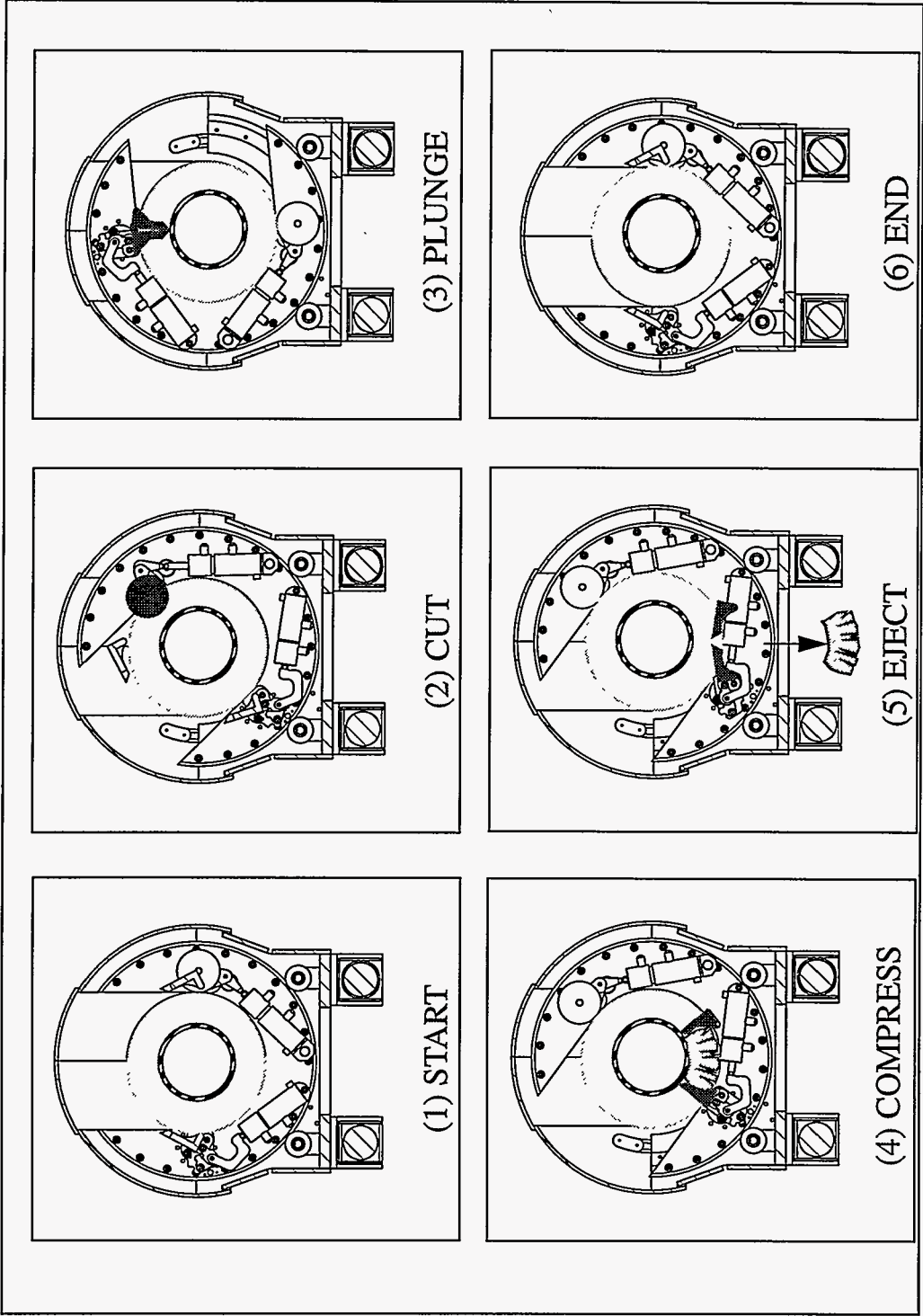



Figure 3-5 : Sequence of steps for the BOA removal module

The operational scenario is one of an infinite loop of sequential tasks as shown below:

- Facility Access.....Deploy system-dolly/handler to desired abatement site
 - System CheckoutPower-up system and test functionalities
 - Pipe-Prep.....Clear 8” long section of L&I using 1-foot glove-bag
 - DeploymentReach tool to desired location and align with pipe
 - Clamping.....Clamp feet onto pipe and release handling mechanism
 - SealingClose sealing enclosure around removal module
 - Vacuum.....Enable pump and draw vacuum
 - WettingEnable fluid flow to wet insulation during cutting/paddling
 - Circumferential cuttingPlunge cutter and cut +/-180°
 - PaddlingPlunge paddles and rip longitudinal seam
 - CompressionCompress L&I by counterdriving c-gears
 - Ejection.....Eject L&I by overdriving paddle mechanism
 - Stowage.....Retract paddles & cutter to stowed position
 - EncapsulationSpray encapsulant agent to seal in all exposed surfaces
 - LocomotionInch along pipe in 1.5” increments over 6” stroke
- 

The overall process depicted by the looping arrow above is estimated to take no more than 7.5 minutes per 6-inch section of L&I (worst-case). A detailed breakdown of the individual activities and estimated times for each is shown in Figure 3-8.

The overall weight for the current prototype lies at 115 pounds, as detailed in the listing below:

Sub-System	Entity	Weight [lbs]
Locomotor	All	53
Remover	All	50
Sealing	Shell	5
Miscellaneous	Fasteners, Screws, Hoses, etc.	7
TOTAL		~115

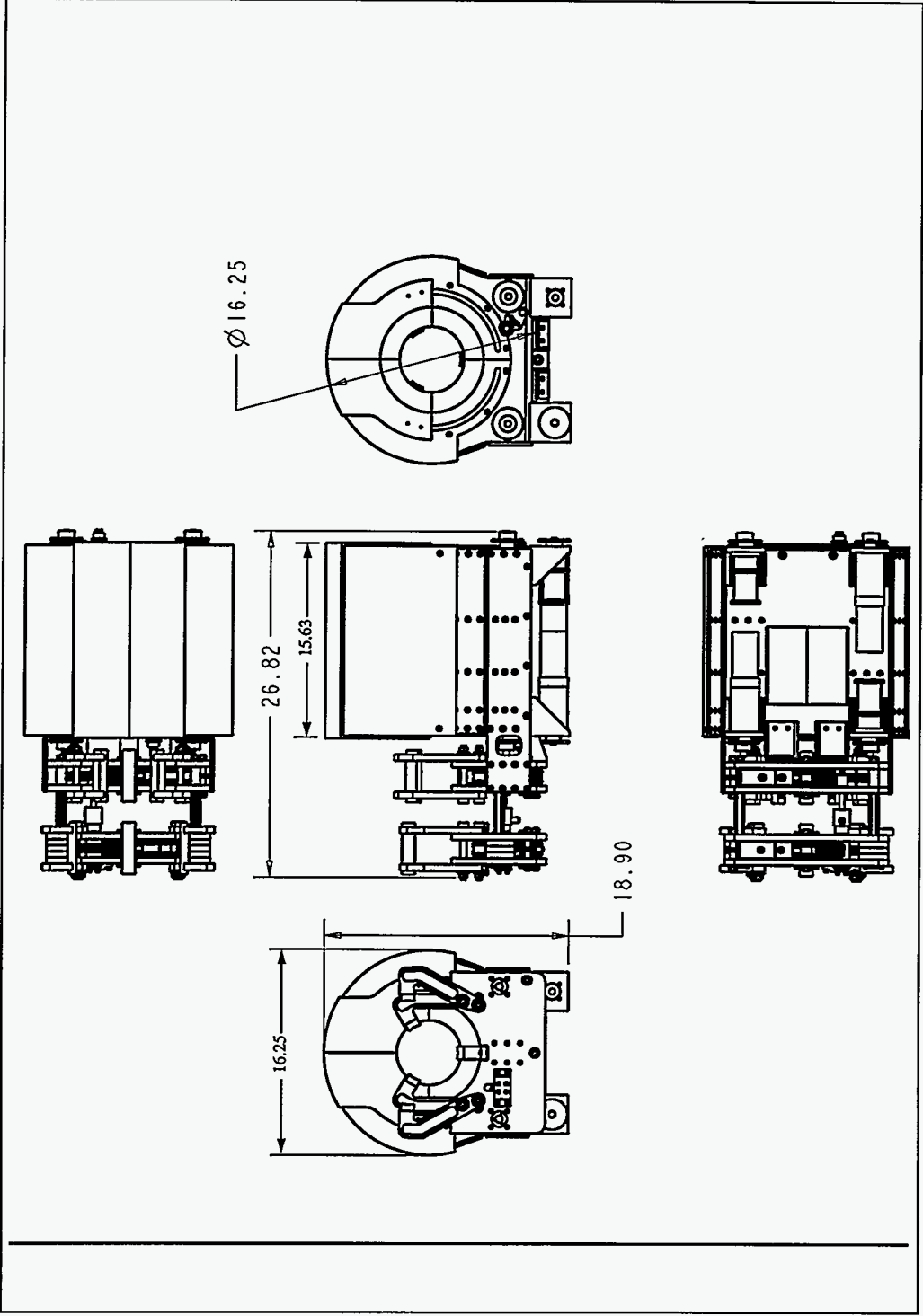

Figure 3-6 : Dimensional views of the BOA robot pipe crawler (dimensions in inches)

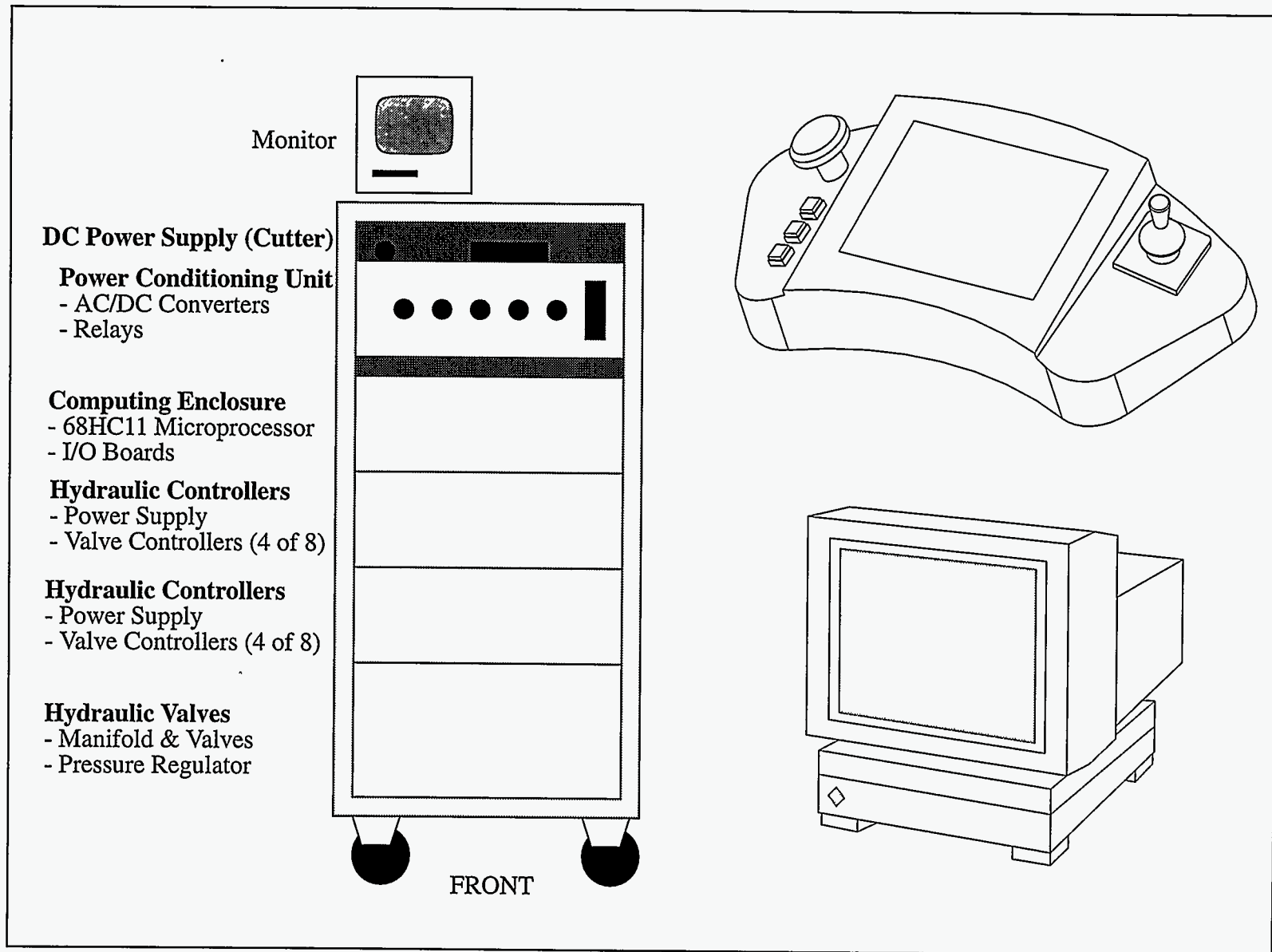

Figure 3-7 : Overview layout of the movable control rack and the portable operator console and the SPARC development workstation

BOA System Activity	Details	Duration [sec]	Run-Time Chronology [mins]															
			1	2	3	4	5	6	7	8								
Axial Translation	4x1.5" @7sec. ea.	28	█															
Wetting Agent Application	Parallel activity	282	█															
Circumferential Cutter Engagement	Dip-in cut	1	█															
Circumferential Cut	feed ~ 0.2"/sec	120	█															
Circumferential Cutter Retraction	Dip-out motion	1			█													
Paddling Mechanism Alignment	C-gear rotation	20			█													
Paddle Engagement	Plunge paddles	5			█													
Compression of L&I	Counterrotation	120				█												
L&I Ejection	Paddle eject	15								█								
Paddle Retraction		2								█								
Encapsulation System Alignment	Rotate C-gears	5								█								
Encapsulation Application	Counterrotation	12								█								
Sealant Drying	Dwell time	120	█															
BOA Abatement Time		449	█															

Figure 3-8 : Process timeline for a typical abatement cycle (productivity of 2 to 8 feet per hour)

3.4 Pre-Testing

Pre-testing was identified as a task to allow for the functional testing of the robot and the setup and testing of the simple pipe network to be used for experimentation and demonstration purposes. Each of the subtasks is detailed further below.

3.4.1 Robot Functionality Tests

The robot's functional performance characteristics were to be tested based on a test plan drafted in the summer of 1994. The system functionality testing focussed on determining the functional problems to ensure that the mechanisms worked as intended. Before any performance measures could be determined, the individual subsystems had to be exercised and tuned to ensure the most optimum overall performance.

We identified the following sub-systems as relevant for such a systems functionality test: (a) control console, (b) electronics rack, (c) hydraulic system, (d) locomotor, (e) c-gears, (d) paddle, (e) cutter, (f) vacuum hood, and (g) the encapsulant system. The results for each of the tests is summarized by subsystem below:

- **Control Console**

All systems, including the touch-screen, joystick and the kill button worked as expected. We made continued use of the system and found it to be reliable and extremely useful in operating a system as complex as *BOA*. For future versions, we believe that if the system could be simplified, a simpler button-box, akin to those used for overhead gantry cranes, would suffice to control the robot.

- **Electronics Rack**

The control rack worked flawlessly and proved to be easily serviceable. Most of the unit's space was occupied with hydraulic controllers and valves, which could be easily shrunk should we decide to go to an electric system.

- **Hydraulic System**

Initial run-up problems with insufficient pressure and flow-rate from the hydraulic pump were remediated to receive better cooling and we chased down all plumbing and electrical problems. The system then worked flawlessly.

- **Locomotor**

The locomotion system, including the clamper was tested and found to need some subtle yet important improvements. The clamping pads were found to need a combination of pointed and hardened setscrews to avoid slippage due to vertical or cantilevered loads, and one clamper (in this case the front clamper) was needed to self-center the locomotor on the pipe, requiring it to have rounded edges that would not dig into the pipe. As a future modification, the bottom clamp-shoes should have the pointed setscrews, while the top shoes should be rounded and plain.

The rigidity of the locomotor needed to be increased, which we accomplished using an additional set of side-plates and cam-follower bearing supports (increased rigidity between the locomotor and the remover), and a remover-mounted beam and roller-follower that would roll along the pipe (increased rigidity during locomotion when only one clamp is attached to the pipe). Otherwise, the system was found to work flawlessly once modified and tuned.

- **C-gears**

The c-gears were found to operate flawlessly, but it was noticed that in future operations they would have to be better shielded and protected from the debris created during cutting. This was not only the case for the gear-teeth, but also the support T-rails which were lubricated aluminum-on-aluminum contact areas. In the future, proper shielding and dissimilar materials should be used for the T-rail section, and its cantilevered action (distance between gear and T-rail) should be minimized. In addition, the T-rail support for the c-gears could be brought up higher so as to just allow the mounting to the pipe - making assembly trickier but resulting in

a stiffer system. The pinion-gear indexing and preloading worked well, but the chain-tensioner needs to be better secured in the future to not allow motion despite loads. A brass-key could then become the shear-point of the mechanism. Hose routing was an issue for the hydraulic system - an effort should be made with the electric solve to avoid long cable lengths and the need to do a 360 deg rotation of any c-gear (cabling nightmare and pinion indexing very critical). In the current prototype system a set of clamps and a counterweight were used to ensure that the hose routed properly during operation.

- **Paddles**

The paddles were found to work as intended once properly tuned and shimmed to remove clearances. The large cantilever was found to be a problem in the presence of no longitudinal cut, and the size and number of teeth is not needed in that case anyway. We hence recommended that the paddles be supported on both sides and possibly made immovable. In addition, the intent was to also reduce the number of actuators, since dig-in was found to not be effective and ejection to not really add much to the system's handling of L&I - hence actuators to move the paddles are not really needed. Tapered lead-ins were successfully used but their value does not seem to justify the effort. The compression shell clearance was found to be excessive and should be reduced in the next iteration.

- **Cutter**

The cutter mechanism was a high-speed (10,000 RPM) diamond-grit coated steel blade mounted off-center on a plunge mechanism. The cutter method worked very well on all types of L&I materials, but the life of the blade on aluminum was limited if wetting agent was used (gumming). The off-center gear-train was unprotected and the excessive dig-in loads created excessive bending and slop in the system so as to continually destroy gears and require excessive running currents from the motor. We recommend increased support and protection of the c-gears in the next phase (if this cutter type is used).

A new cutter method consisting of toothed endmill cutters is currently proposed to replace the bladed. Chicken-wire has been found to not be part of any substantial lagging system within the DoE and has since been recommended to be dropped as one of the types of lagging. Modified endmill cutters are thus proposed, and could be rigidly mounted and require no real drivetrain nor plunging mechanism - we will explore this in the next phase.

A deeper cut to the pipe seemed needed for fiberglass (irrespective of lagging type) but not for CALSIL insulation. More tests in the next phase will determine the appropriate cutting depth.

- **Vacuum Hood**

The vacuum hood was found to work well, except that the next version should be LEXAN rather than plexiglass. The stationary and dynamic seal areas need to be better designed, including gasketing and o-rings and rubber seals and longer brush-seals. A better fastening and holding approach should also be conceived.

- **Encapsulant System**

The encapsulant system was designed to completely soak the L&I, to the point where it is able to generate a higher flow rate and better coverage than the human approach using spray guns or bottles. The wetting and encapsulant systems were combined due to the use of a chemical that does the job for both tasks. It was found that c-gear mounted nozzles near the cutter and paddles worked well. The size of the nozzle orifice was crucial to get the proper misting and flow-rate actions. The pump needs to have better flow-control including the ability of immediate on/off control. It was determined that we typically over-saturated the piping and insulation and created excessive run-off which would be problematic in vertical abatement conditions as it would run down the pipe uncontrolled.

3.4.2 Pipe Network Construction

The pipe network consists of a simple U-shaped configuration made from five sections of 8-foot long four-inch (nominal) diameter steam piping. The system is supported from pipe hangers underneath a catwalk. This arrangement allows us to test the crawler on the horizontal and vertical pipe-runs through the use of a lift platform to handle the 115-pound weight of the robot.

We use this network and clad it with fiberglass insulation and aluminum lagging for insulation removal experimentation purposes. Since we are not permitted to work with asbestos¹, we selected fiberglass as the simulant. It is a less friable, yet a more 'spring-like' insulation material than the ACM that we expect to find at the DoE sites (powderous, rock-wool, cardboard paper, half-round blocks). Fiberglass is a tougher material to work with than the powderous, rock-wool or cardboard-paper material, except for the generation of airborne fibers. The (CALSIL) block-like insulation has been used to size the strength and power factors for the removal unit and is hence considered to not be a limiting factor.

Upon further review and recommendation, we decided to switch to CALSIL as the ACM-simulant since its properties seem to more realistically represent the ACM in DoE sites. Initial tests have been conducted and will be continued in the next phase.

1. The concerns raised by CMU's Environmental Health & Safety (ES&H) office caused us to drop the plans to work with ACM due to the high costs and safety concerns.

3.5 Robot Abatement Experimentation

The robot abatement experimentation represents the most important task to be performed during this phase in order to generate knowledge to be used in the design of the next phase integrated robot system. Toward that end, we developed a three-level experimental plan that focussed on three key aspects of BOA's capabilities, namely system performance, process performance and overall performance.

3.5.1 Test-plan description

The description of the test types is given below, while results of the tests are discussed on the subsequent pages:

- **System Performance**

In the system performance experimental phase, we tested the overall performance of each key sub-system. These tests occurred after the robot had been assembled, and that each subsystem is tested individually. Many of the tests involve more qualitative or overall measures of performance, requiring the use of additional measurement or observation equipment. We identified the following sub-systems which were to be tested individually as part of the whole mechanism: (a) locomotor, (b) clamper, (c) remover, (d) wettant/encapsulant system, (e) hood, and (f) the vacuum system.

- **Overall Performance & Specifications**

As part of the overall performance specification tests, we determined the key performance parameters that were needed to measure overall performance - namely those parameters that ultimately matter in an evaluation process to establish the suitability of this remote abatement robot system. They are: (a) removal methods, (b) containment efficacy, and (c) overall cleanliness.

3.5.2 Summary of Results

The main results of our experiments can be split into functionality and abatement results with their own separate criteria. This section summarizes these in tabular form and provides for a comparison with the goals set for the conclusion of the first phase. A discussion of the results concludes this section.

- **System Functionality Results**

A summarizing table with all the functionality test results is appended here and shows some of the results and comments we generated after our testing period.

CATEGORY	RESULTS & COMMENTS
Rigidity	Remover sag reduced through pipe follower and side-plates <i>Increased rail χ-section & roller-follower arm</i>
Clamping	Minimum contact pressure needed to avoid slippage <i>Use of pointed setscrews and rounded clamps reduces slippage and alignment problems</i>
Cutting	Circular cutter works well but cannot be made to reach to the pipe surface <i>Depth of cut to the pipe is needed for fully separated section - try alternate cutters Chicken-wire & aluminum are crucial design drivers (cutting and springing)</i>
Paddling	Longitudinal cut is essential to ensure full dig-in & removal <i>If circumferential & longitudinal cuts exist any L&I is removable</i>

CATEGORY	RESULTS & COMMENTS
Compression	Paddling forces are dominated by compression shell size No real compression ratio was achieved due to ejection chute <i>Increase compression shell size to reduce forces and create recyclable material</i>
Vacuum System	Measured 0.005 in/H ₂ O at 100 cfm and acceptable fiber-count values <i>Better sealing and no sliding hose seals are advisable</i>
Encapsulant System	Pulsing and flow-control needed to avoid excess fluid run-off <i>Entire robot to be waterproof to allow for full immersion cleanup</i>
Brushing	Wire brush works very well <i>Fine tune brush design and circumferential application</i>
Mechanism	Number of small problems (gear jams and wear, dirt, grime and cuttings an issue) <i>Fully enclose, seal and protect gearing and other sensitive components</i>

We found that a few tuning and design modifications were able to make the locomotor rigid and the clamping reliable. The cutter was found to be the weakest member due to its high speeds, loads and unprotected gearing. Deeper cuts seemed to be needed for fiberglass, but CALSIL does not seem that susceptible to cutting depth. Paddling actions were unable to puncture and rip aluminum and chicken-wire lagging, while plain paper-tape and fiberglass simply yielded. The compression cycle worked very well and at much lower forces than expected due to the increased chute size, which we propose to enlarge even further. The vacuum system worked well, except that better stationary seals (o-rings, gaskets) and dynamic seals (longer brush-seals) are recommended - all sliding tether protrusions should be eliminated or fully sealed as well. The brushing method was successful and now needs to be fine-tuned (brush selection) and incorporated into the circumferential mechanism. Overall we need to better seal, enclose and protect the components and make them submersible for cleanup after abatement due to excessive build-up of fibers and dust.

•L&I Abatement Results

A summarizing table with all the abatement test results is appended here and shows some of the results and comments we generated after our testing period.

CATEGORY	RESULTS & COMMENTS
Productivity	Abatement of 4 to 5 feet/hour - dominated by cutting process <i>Simultaneous cut/compress cycle</i>
Containment	Achieved a net emission of 0.0103 fibers/ccm/8 hour shift <i>Improve static/dynamic sealing and make a fixed-exit tether</i>
Insulation	Fiberglass insulation: 1.5" - <i>Increased variations possible with more clearance</i>
Lagging	Paper-tape, aluminum sheathing, chicken-wire <i>Paper can get hung up on paddle. Aluminum & wire splay open after cutting</i>
Compaction	None really - <i>Not needed: can be acceptably handled as a post-process</i>
L&I Ejection	Simple drop-off or removal due to open ejection chute <i>Include a simple grab/fling mechanism (e.g. running toothed rubber belt)</i>

CATEGORY	RESULTS & COMMENTS
Bagging	In-situ handling or dropped into attached 6-mil poly-bag sufficient <i>Allow the operator to switch out bags (12 feet fit into 1 bag)</i>
Wetting	Coverage of 100% with about 5% absorption (excessive run-off) <i>Better flow-control and separate spray circuits (cutter, sealant, etc.)</i>
Encapsulation	Face-cut seal fully covered and sealed Encapsulant dries in 30 minutes => walking over it is not an issue
Operational Scenario	Horizontal pipe abatement of 20 feet to date - 6 feet continuous to date Not able to abate vertically due to bent mechanism - <i>repair & retry</i> Mechanism too heavy and cumbersome <i>Simplify design, lighter/stronger materials, separate locomotor/clamper & remover</i>

The productivity of abatement we achieved exceeded that of a human crew, but can be easily doubled by increasing the bite-size and by combining cutting and compression actions. The containment figures are encouraging, even with a large number of seals and excessively large sliding tether seals. Variations in insulation thickness and alignment needs to be compensated for in the future with lead-in sections and larger internal clearances. Teeth are no longer recommended and fully cut lagging is best held in place in order to be easily compressed and removed. Compaction was not occurring due to the increased ejection-chute size. We recommend to increase it even further to make removal easier and further reduce the compression/paddling forces. A separate grab/fling mechanism will be needed to handle the cut and removed L&I section - especially if abating in the vertical position where gravity does not pull the section into the bag. Manual bagging worked quite well and no further mechanical sealing/handling system is currently proposed. However, attachment of the glove-bag should be easier and replaceable while retaining full containment. The location of the vacuum system should be reconsidered to allow for better removal of the material from the cutter and through the bottom of the glove-bag. A better controlled flow rate and on/off flow controller needs to be integrated to reduce excess encapsulant delivery, saturation and leakage. Applying and walking over the encapsulant was not an issue as previously thought. The overall system needs to be lightened and the off-board logistics better integrated and controlled. The actual emplacement and removal of bags and the robot itself need to be better detailed to ensure compliance with EPA and OSHA regulations.

•Overall Comparison

The table below compares the goals for this phase with the achieved results from our experimental program. We have taken the liberty to grade ourselves:

	GOAL	RESULTS	GRADE
Insulated piping	4.5" OD; 1-2" thick	full-depth cut hard	B
Lagging	all, except stainless	OK - long. cut needed	C
Pipe cleanliness	brush demo (off robot)	OK	B
In-situ bagging	no	yes, simple bag	A
Waste compaction	yes (4:1 estimate)	no, not needed with chute	-
Removal around obstacles	no, only face-cut spray	OK	A
Locomotion past obstacles	no	no	-
Insulation wetting	100%	yes (5% absorption)	A
Pipe encapsulation	100%	yes	A
Operational mode	Self-propelled	yes	A
	Cleared pipe to start	yes (15" required)	A
	Manually emplaced	yes (117 lbs)	B
Full emission containment	0.010 fibers/ccm/8-hours	0.0103 fibers/ccm/8-hour	B
L&I removal - any orientation	yes	OK - horizontal	A
		failed - vertical	D
Abatement productivity	2 to 8 ft./hr	4.7 ft./hr	A
Self-cleaning	no	no	-

We met and/or exceeded goals set for abatement productivity, horizontal abatement, emission containment, the operational mode (except for the excessive robot weight), wetting and encapsulation, pipe cleanliness, bagging and insulation and lagging types we could handle. Two areas that clearly need improvement are (i) the need for a deeper and longitudinal cut, and (ii) the ability to abate in the vertical position. The former will be incorporated into the re-design of the Phase II robot, while the latter will be retested in Phase II (damage to a major component of the Phase I robot during the experimental phase precluded us from performing the vertical experiment).

4.0 Phase I Conclusions

This section details overall conclusions drawn from the complete Phase I.

4.1 Scope of Work

The scope of work was left sufficiently vague at the start in order to allow sufficient flexibility in performing the actual body of work. As determined later, the problem turned out to be harder to solve than expected, and experimental testing had to be expanded and resulted in a two-month delay of the overall demonstration of our effort. The lesson learned here is that on unquantifiable works, a substantial up-front experimentation and even pre-prototyping effort should be included to properly scope and budget the envisioned effort.

4.2 Success Criteria

The success criteria were sufficiently clear to drive not only the performance specifications, but also the details of the experimental plan in order to fully meet those criteria. We believe the development of clear success criteria to be an important area often overlooked, which helped provide experimentation and evaluation focus and metrics. We need to also continue improving the process of determining realistic and measurable goals.

4.3 Overall System Performance

Based on the performance metric comparison and grading scheme detailed earlier, we believe that our overall performance metrics were sound and complete. Our performance with respect to the metrics is open to debate, but based on the review panels' feedback, we believe that our Phase I effort can be deemed a success. Additional work is needed to harden and improve upon the process and the engineering, and we have identified Phase II as the appropriate time. The current prototype system taught us invaluable lessons and the robot remains available for further testing. Based on the Phase I test results we have drawn a set of technical and programmatic recommendations for a Phase II effort (with the help of the Phase I review panel) - these are detailed in the following sections.

4.4 Phase II Motivations

We believe that there are several key points worth mentioning which form our argument for continuation into an additional phase to complete the work begun here. We simply list them below as they are self-explanatory and are further justified in Section 5.0 on page 38:

- **We believe the process can be successfully automated.**
- **We now understand the process sufficiently well.**
- **We have a prototype that has, and can continue to, generate experimental data.**
- **We now have sufficient results and information to build a more capable and fieldable prototype through re-design and optimization.**
- **We can now apply operational criteria to the next prototype.**

5.0 Phase II Recommendations

Recommendations that CMU and the DoE review panel made at the Phase I review are clearly split along technical and programmatic lines. We will detail these separately in this section, thus providing a basis for the proposed scope of work for Phase II detailed later in this report. Please note that these recommendations represent a collection of edited and re-phrased remarks agreed upon by the whole committee and project team as viable and desirable for continuation of this project.

5.1 Technical Recommendations

The technical recommendations made by the CMU project team can be summarized in a tabular form, and they are shown in such a form below. Please note that they are split into areas of (i) *operations*, (ii) *configuration* and (iii) *design*. The currently embraced concept for a Phase II system is shown in Figure 2-1 on page 8.

5.1.1 Operations

The topic of operations reflects the characteristics of the system's ease of deployment and operation, compliance with regulations, applicability to a wide range of piping, and its overall productivity.

AREAS	MODIFICATIONS
<i>Applicability</i>	<ul style="list-style-type: none"> - Straight piping with friable and block-like insulation with paper, plaster & aluminum lagging - Insulation thicknesses: 1 < t < 3 inches - Usable only on single pipe diameter (4, 6 or 8 in. dia.) but designed to be scalable
<i>Productivity</i>	<ul style="list-style-type: none"> - Increased to between 4 and 8 feet per hour
<i>Deployment</i>	<ul style="list-style-type: none"> - Manual deployment off floor/platform with work positioner (OEM-supplied); Remote system deployment is possible
<i>Containment</i>	<ul style="list-style-type: none"> - Self-contained and within legal limits during robot and bag re-emplacment
<i>Operator</i>	<ul style="list-style-type: none"> - Worker abates starting locations and around all obstacles

Note that we are striving for an OSHA-compliant system with sufficient productivity to exceed human performance by attempting to achieve 4 to 8 feet per hour of abatement productivity. The robot should be easily usable by on-site contractors by making it straightforward to deploy, the operator interface simple and the robot system reliable and requiring low maintenance. The system should be designed to be widely applicable across the DoE complex by allowing various pipe-sizes and varying thicknesses of insulation. The issue of whether single or multiple pipe-sizes will be resolved upon conclusion of a site study to be performed at the beginning of Phase II. Compliance with EPA and OSHA regulations will be ensured through careful design and their participation during the study, development and deployment stages of the currently envisioned Phase II. We will accomplish these goals through careful analysis of existing marketing and site information as well as a detailed review of human abatement practices and the cost/benefit of employing a robotic abatement system.

5.1.2 Configuration

The topic of configuration relates to the overall functionality and design of the robot's abatement tools and processes. We have identified the following areas in which improvement is desirable and possible:

AREAS	MODIFICATIONS
<i>Modularity</i>	- Separate remover/locomotor to reduce handled weight
<i>Variability</i>	- Design of exchangeable components for various pipe diameters (4, 6, 8 in), but built for only one diameter
<i>Cutting</i>	- Full-depth cutting system & longitudinal cut
<i>Paddling</i>	- Fixed paddles without motion - used for holding lagging and compression only
<i>Compression</i>	- Coupled c-gear counterrotation
<i>Ejection</i>	- Grabbing/flinging mechanism inside of chute with increased chute opening dimensions
<i>Brushing</i>	- Full circumferential wire brush system

The intent for Phase II will be to possibly develop the *BOA* crawler in separate pieces for reduced weight handling by an operator when emplacing/removing it on/from the pipe. The intent will be to develop the next generation clamber and remover systems to allow them to handle variable diameter pipe and insulation systems. We will determine through the study whether it is most advantageous to develop separate locomotors and removers for different pipe sizes, whether a certain backbone with exchangeable components should be developed, or whether it is desirable and technically feasible to develop a single device that adapts to several combinations of pipe sizes and L&I conditions. It has also been recommended that we expand the current circumferential cut to achieve a deeper cut that cuts closer to the pipe. It was also determined that we will need to generate a longitudinal cut to split the L&I material and allow for easy entry and start of the compression cycle. Based on our experience with the cantilevered and actuated paddle systems, we would attempt to develop a fixed paddle system that could be supported on both ends to reduce bending loads on the paddle and supporting c-gear mechanism. The compression cycle was found to be invaluable, even though it is only used to remove the L&I off the pipe. Sizing of the ejection chute will be guided by the compression/removal forces exerted on the paddles, making it possible for L&I to simply fall off the pipe or be easily handled by an ejection mechanism that transports or flings the removed L&I into the attached glove bag. It became very clear that the expected 'bake-on' phenomenon due to condensation and rusting in old pipes, will have to be addressed. We demonstrated a small area of a circumferential brushing cycle which will have to be expanded to cover the whole pipe. The challenge will be the integration of this process into the existing mechanical system.

Overall we believe that the challenges will mainly lie in the areas of weight reduction, mechanical simplification and the integration of additional processes such as longitudinal cutting and circumferential brushing into the overall abatement process. We propose to have a conceptual design complete by the time the development stage of Phase II begins, in conjunction with a presentation of our study results.

5.1.3 Design

The topic of design refers more to the more detailed technical improvements we recommend to be executed during the design and implementation stage in Phase II. They are detailed as follows:

AREAS	MODIFICATIONS
<i>Materials</i>	- Castings and fiber-composites to reduce weight
<i>Complexity</i>	- Reduce the number of independent degrees of freedom
<i>Interfacing</i>	- Mechanical interface for use of work-positioner/robot
<i>Actuation</i>	- Purely electrical; 110VAC, 30 Amp circuit
<i>Tether</i>	- Single power and communications tether
<i>Locomotion</i>	- Larger stroke only if increased rigidity is achieved to avoid remover sag
<i>Sealing</i>	- C-gear mounted nozzles for full pipe and cut-face coverage with flow-controlled circuits
<i>Vacuum</i>	- Improved static seals (o-rings, gaskets) with longer brush seals on front insulation - Increased flow-rate vacuum system
<i>Bagging</i>	- Mechanical ejection support means - Manual bagging system exchange (clamped-on glove-bag)
<i>Cleaning</i>	- Unit rated for immersion and spray wash-down
<i>Abatement Cycle Time</i>	- Increased bite-size, reduced cutting time, or coupled cutting/compression/brushing cycle

We would like to explore the possibility of using metal composite materials in the structural elements of the system in order to reduce weight. We will do so if it is a cost-effective approach only - actual optimization for mass-production is not one of our charters but we will push the prototype as far as reasonable in Phase II. Our design effort will also attempt to reduce system complexity and thus number of separately actuated degrees of freedom. We will do so by attempting to combine certain steps such as locomotion and longitudinal cutting and compression with circumferential cutting or slaving the compression cycle to a single actuator, etc. A mechanical interface will be provided on the robot to allow for attachment of a work-positioner or a mechanical robot arm for possible human and robotic handling scenarios. Actuation will be purely electrical - we envision the need for a 110VAC/30 Amp circuit for the entire system (robot and off-board logistics). The current tether system will be simplified to rely on a bulkhead interface at the robot and possible routing along/within the vacuum hose, thus eliminating any sliding and open seals on the robot system. Locomotion of the Phase I prototype was satisfactory in terms of speed and performance, but we might be able to increase speed to increase productivity. The wetting and encapsulation will rely on the same spray/nozzle system currently in use, but we will need to have better flow and on/off control to reduce excessive wetting and excess runoff. The vacuum hood requires better seals (gaskets and o-rings) and we will need to provide gaskets or o-rings for the metal-to-metal joints. An increased flow-rate vacuum will be procured and better brush-seals installed along the dynamic seal interfaces on the frontal L&I and the rear piping. A better open/close mechanism and holding hardware will be designed into the transparent hood. The bagging will be performed by a simple grabbing/flinging belt-driven mechanism to eject the removed L&I into an attached glove-bag, which allows the operator to reach in and aid the ejection should it be needed. All components and connectors/seals/bearings/gears will be rated for full immersion and spray washdown as post-cleaning is important. By increasing the bite size through increased removal chamber length, and combining cutting/locomotion and compression, we expect to increase our abatement productivity by at least a factor of two to four to achieve 8 feet per hour.

5.2 Programmatic Recommendations

Programmatic changes proposed by the review panel focussed on a change of scope of work for Phase II, including an up-front study period and a DoE field test at the conclusion of the development work originally proposed for Phase II. Both these additional tasks are detailed below:

• Systems Approach Study

The review panel requested that we perform an additional set of survey, analysis and networking activities to clearly develop economic and site-based justifications to guide the design and commercialization efforts of Phase II. The committee identified four main activities, including (i) a regulatory analysis, (ii) a more directed and thorough site evaluation, (iii) a comparison of human vs. robotic abatement techniques and costs, and (iv) a cost/benefit analysis for the complete system once applied to the DoE sites. Each of these topics is further detailed below:

- *Regulatory Analysis (OSHA, EPA, DoE)*

We intend to review the standing EPA and OSHA regulations to see what the currently mandated work practices are for human asbestos abatement operations. In addition, we will compare these to the standing regulations that DoE site contractors adhere to when they are performing the same tasks on DoE facilities. Furthermore, we will identify and involve key people within the EPA and OSHA organizations to comment on the current, and participate in the future developments of the BOA system (research and enforcement).

- *Site Evaluation*

We will undertake a set of site visits to Fernald and Oak Ridge and confer with Hanford and Savannah River, to gain a clearer picture of their current mileage, status and types of L&I piping based on existing information. We will corroborate and expand said information at Fernald and Oak Ridge and in addition identify a DoE field test site at both and make a recommendation as to where the system should be field tested to be as realistic and representative of the DoE complex as possible.

- *Comparison of Robotic vs. Human Abatement*

An overall comparison between human and robotic performance will be drawn based on data gathered from commercial and DoE abatement contractors. We will visit Fernald and Oak Ridge to corroborate these numbers, and we will train our team to perform our own baseline abatement numbers.

- *Market Study (within and outside of DoE)*

The marketability of the BOA system will be explored in terms of its potential and allowable pricing for equipment and servicing for not only DoE but also commercial applications. This information will allow us to single out appropriate pipe size and types to pursue the design of a system widely usable under certain cost criteria.

- *Cost/Benefit Analysis (targeted at DoE deployment only)*

A cost/benefit study will be undertaken to incorporate all site information, cost and insulation figures to determine what the most cost-effective area and system design should be pursued in order to maximize the return on investment (ROI) or operational costs within the DoE complex as well as in the commercial setting.

• Field Test

The review panel also recommended that the Phase II not only include a 'cold' test at CMU as planned, but also budget for training, transport, deployment and field test within a DoE site such as Fernald or Oak Ridge. We have identified a set of four main activities including (i) permitting, (ii) logistics and transportation, (iii) site setup and training, and (iv) a field test and demobilization. These four sub-tasks envisioned to be executed during this stage are

detailed below:

- ***Permitting, Site Training & Compliance***

A few weeks will be spent preparing and all relevant permits and NEPA information for submittal to local, state, federal and DoE-site officials for allowance of the DoE field test. Necessary training for the field test team and other needed education, etc. will be accomplished during that period of time.

- ***Logistics Setup and Transportation***

The logistics needed for the field test will be planned out between CMU and the selected DoE site. These will include site-access, deployment location, on-site power, support personnel, field test logistics, etc.

- ***Site Setup and Training***

A detailed plan will be drafted and submitted to the DoE site for evaluation. The plan will include every detail of on-site deployment, setup and the necessary operator training to deploy, operate and maintain the *BOA* robot system.

- ***Field Test and Cleanup***

We will assist in the setup and execution of the abatement field test at the selected DoE site. In addition, we will be assisting in the demobilization of the entire system upon conclusion of the field test.

Overall, these recommendations have been accepted by CMU and the DoE review panel and have been used to redraft a new scope of work for the reformulated Phase II. An overview of the proposed scope of work for Phase II is included in Section 6.0 on page 43.

6.0 Phase II Follow-on work

6.1 Technical Summary - Phase II

The environmental restoration and waste management problem addressed in the originally submitted proposal focuses on the abatement of asbestos pipe insulation at Department of Energy (DoE) facilities across the entire complex of DoE processing plants. The abatement process targets the removal of asbestos pipe insulation from a large range of pipes (typically hot water or steam) ranging from 8 inches to 12 inches in diameter (with insulation). The objective is to significantly reduce the manpower needed for remediation, reduce the time and cost associated with erecting scaffolding and performing multiple bagging, reduce the amount of airborne asbestos fiber emissions and to remove and package only the asbestos and cladding material. Sites that could benefit from such a system include Building 7 at the Feed Materials Production Center in Fernald, Ohio, and the K-25 uranium enrichment plant at the Oak Ridge Reservation in Oak Ridge, Tennessee.

A key advantage of the system is that waste volume is greatly reduced because the asbestos is separated from the pipes and packaged instead of removing entire sections of asbestos-clad pipe intact. Additional cost savings can be realized because far fewer workers are required for the abatement activity. Economic justification is based on the knowledge that the K-25 plant alone has at least 35 miles of asbestos-clad piping, which if abated at the estimated cost of \$100.- to \$150.- per linear foot using conventional manual techniques would cost \$18.5 to \$28 million and is not scheduled to be completed before the year 2000. The *BOA* crawler and boom vehicle system offer a much improved solution to the asbestos pipe insulation abatement needs in DoE facilities.

We propose to develop an automated asbestos pipe-insulation removal robot system. The proposed dual-robot system consists of a crawler, dubbed *BOA*, which propels along the outside of the pipe, while slicing and peeling off the asbestos insulation. *BOA* is also able to move around valves, junctions and bends with assistance from an operator or a mobile worksystem, while being controlled/monitored by an operator from a safe distance. Generation of airborne asbestos fibers is minimized by use of a vacuum, and by coating the stripped section of pipe with a quick-drying coat of encapsulant agent to trap any loose fibers. We are currently envisioning two deployment modes: (i) a mobile boom vehicle working as a support robot in conjunction with *BOA*, and (ii) a human operator assisted by *BOA*. The latter deployment would involve the use of a human operator to emplace/remove the crawler from the pipe, while he/she tends the supply system and clears asbestos around obstacles (via standard glove-bag method), which the robot could not clean, but had sealed up as it passed by them. A continuous bagging unit attached to the crawler continuously bags and seals the insulation. An off-board logistics support unit containing computing, power system, HEPA filter and wetting/encapsulant fluid systems will be tethered to the crawler and installed on either (i) the end of the long-reach boom of the robotic worksystem, or (ii) atop a man-cage on a shooting-boom vehicle. *BOA* is handled onto/off the pipe and around obstacles either by (i) the dexterous manipulator mounted to the end of the robotic worksystem's heavy-duty boom, or (ii) a manual work positioner mounted atop the man platform on a hi-reach boom vehicle. The bagged insulation is lowered to the floor for removal by workers or another remote system. The bags of removed asbestos can then be processed off-site by decomposing the asbestos chemically, or disposing of it through burial. The remaining pipe can then be sectioned and removed as in a normal decommissioning task.

The proposed multi-month follow-on phase (Phase II) is intended to build on the efforts from Phase I. Overall, Phase II will unfold in three separate and sequential stages. The first 4-month period will be spent on performing site assessments, a market study, a cost/benefit analysis and a review of regulatory guidelines. The second stage (14 months) is the actual period in which we design and build the improved robotic system, including activities such as improving the crawler, developing a packaged off-board logistics support unit, provide for a manual positioning capability, develop an auto-

mated bagging system and provide for an integrated control console and software system. The third stage (6 months) will be to prepare the system for deployment at a real DoE site (5 months) and assist in the performance of a real abatement demonstration at the selected site (1 month). A cold-test will be held at the end of the second stage at CMU on CALSIL insulation with a variety of expected lagging materials, demonstrating the full operational deployment sequence, while the DoE field test will be held at a yet-to-be-selected DoE site such as Fernald or Oak Ridge. Emphasis will be placed on leveraging from the results of the first phase effort, and ongoing DoE development programs in the areas of mobile worksystems and asbestos processing equipment. Likewise, the asbestos packaging approach will consider the needs of the insulation processing system currently under development by KAI Technologies for the DoE.

6.2 Overall Objective

The Phase II effort will focus on three consecutive efforts: (i) a systems approach study, (ii) the system development and (iii) the field test. The entire phase is scheduled to last 22 months, with a scheduled deployment and field test at a DoE site in October of 1996.

The systems study will cover such areas as a regulatory analysis of current EPA/OSHA and DoE requirements and work practices, a comparison to current ACM abatement practices, a market study within and outside the DoE, a cost/benefit analysis for operations within the DoE and a market study on using the BOA system within DoE and in the commercial abatement industry.

The systems development stage will conceptualize, design, build and test the robot prototype which best serves all critical criteria developed during the study, namely cost/benefit, marketability, wide use within DoE, etc. We will concentrate on refining the pipe-crawler based on the expanded capability requirements identified in the study, as well as the conclusions drawn from the experimental test-phase at the end of Phase I. At the conclusion of this stage, we will hold a cold test at CMU for all interested DoE and commercial entities on ACM simulant on a mock-up pipe-network. Successful demonstration at this point will be considered as having met all the success criteria of this phase.

The site field test will involve a variety of activities such as NEPA documentation and acceptance, EPA/OSHA and site permission and acquisition of all local, state and federal permits in order to deploy the BOA system within a DoE site such as Fernald or Oak Ridge. The system will then be transported and deployed to a selected site, all logistics having been planned out and coordinated with the site. A field test will be conducted on piping networks clad with ACM insulation.

In summary, Phase II will involve efforts in the following three areas:

- **Systems Approach Study**

- *Regulatory Analysis (OSHA, EPA, DoE)*

We intend to review the standing EPA and OSHA regulations to see what the currently mandated work practices are for human asbestos abatement operations. In addition, we will compare these to the standing regulations that DoE site contractors adhere to when they are performing the same tasks on DoE facilities. Furthermore, we will identify and involve key people within the EPA and OSHA organizations to comment on the current, and participate in the future developments of the BOA system (research and enforcement).

- *Site Evaluation*

We will undertake a set of site visits to Fernald and Oak Ridge and confer with Hanford and Savannah River over the phone, to get a clearer picture of their current mileage, status and types of L&I piping based on existing information. We will corroborate and expand said information at Fernald and Oak Ridge and identify a field test site at both and make a recommendation as to where the system should be field tested in as realistic and representative conditions as are prevalent throughout the DoE complex.

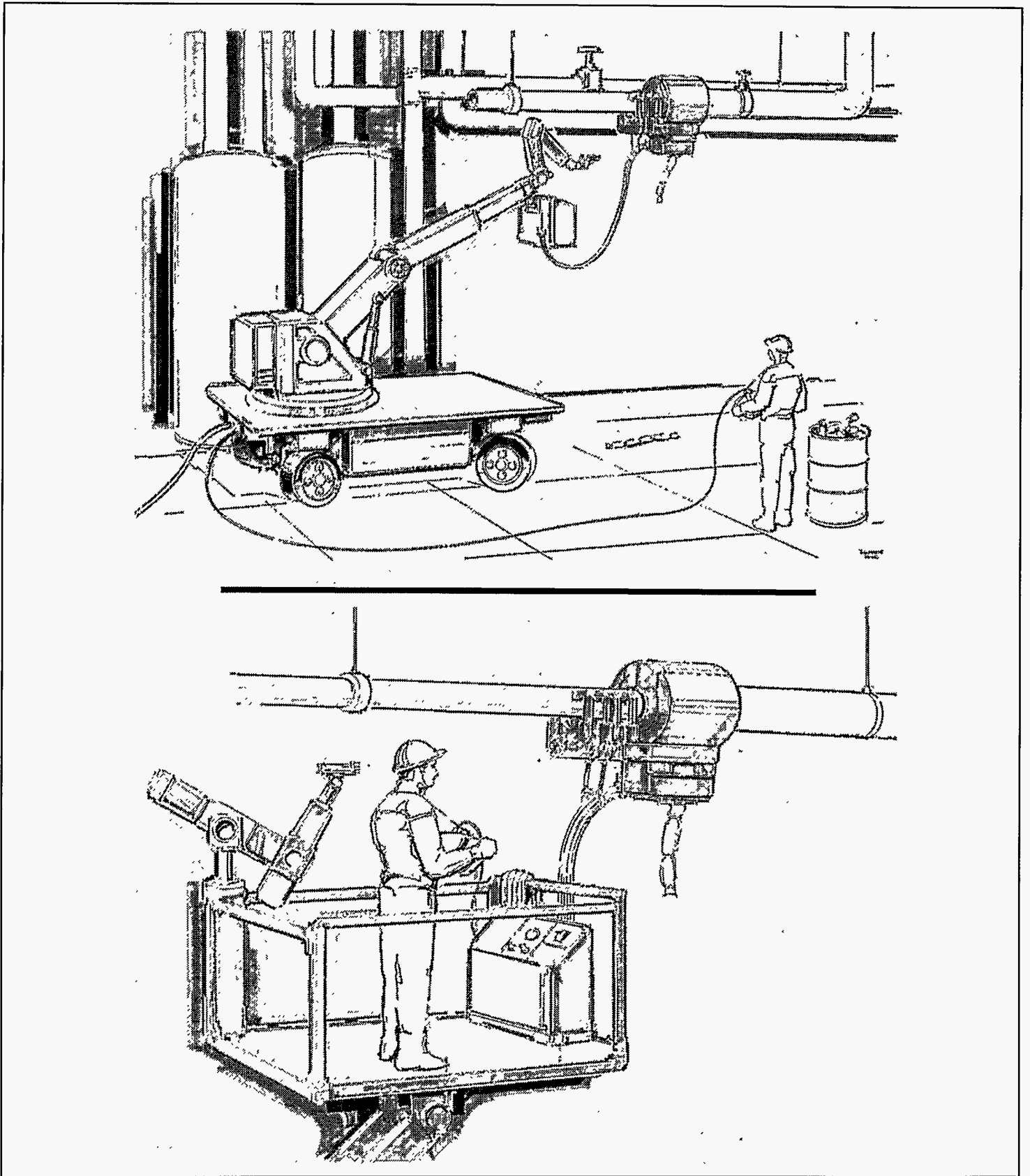

Figure 6-1 : Operational scenario for the pipe-asbestos insulation removal robot system in a fully robotic and human assistance modes, showing the asbestos removal and packaging actions in progress

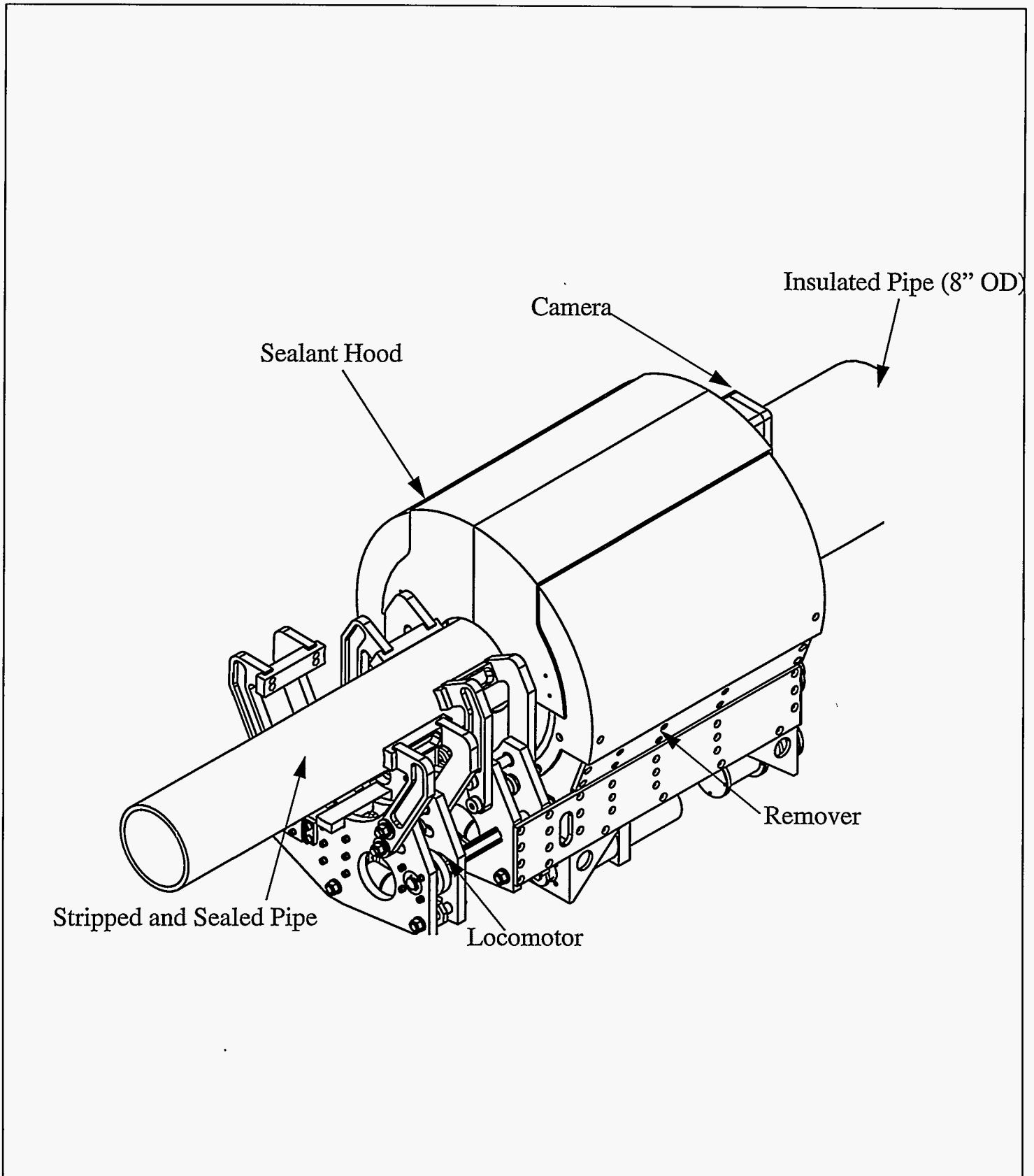

Figure 6-2: View of the BOA crawler robot developed in Phase I

- ***Comparison of Robotic vs. Human Abatement***

An overall comparison between human and robotic performance will be drawn based on data gathered from commercial and DoE abatement contractors. We will visit Fernald and Oak Ridge to corroborate these numbers, and we will train our team to perform our own baseline abatement numbers. Market Study (within and outside of DoE)

The marketability of the BOA system will be explored in terms of its potential and allowable pricing for equipment and servicing for not only DoE but also commercial applications. This information will allow us to single out appropriate pipe size and types to make the system as widely usable under certain cost criteria.

- ***Cost/Benefit Analysis (targeted at DoE deployment only)***

A cost/benefit study will be undertaken to incorporate all site information, cost and insulation figures to determine what the most cost-effective area and system design should be pursued in order to maximize the return on investment (ROI) or operational costs within the DoE complex as well as in the commercial setting.

• **Systems Development**

- ***Pipe-crawler Enhancements***

The pipe crawler will be modified to (i) implement the changes recommended after the experimental program is completed at the end of Phase I, and (ii) allow for multi-diameter pipe applications. In addition, the system will be re-designed from the ground up to optimize such criteria as reliability, ease of manufacture and maintenance, integration and use of OEM components, etc.

- ***Automated Bagging System***

The automated bagging system will either be specified and acquired from an OEM supplier (yet to be identified), or it will have to be designed and built from the ground up - the former is the preferred choice. Interfacing the system to the poly-bag supply system, the crawler and the HEPA filter system will be an important design task.

- ***Off-board Logistics Support System***

A compact and rugged off-board logistics support unit will need to be designed and built in order to house the power conditioning, computing, HEPA filter and encapsulant systems, and provide for a simple switch-based operator control panel. A hybrid tether will be specified to connect the crawler to this support unit, including power, video, feedback, motor-control, vacuum and fluid conductors and lines.

- ***Vehicle Positioner Interface***

An OEM-supplied manual work-positioner will be specified and acquired from an OEM supplier. The intent will be to customize the system to allow for ease of handling of the BOA crawler if deployed manually from a man-cage atop a shooting-boom platform vehicle. A special-purpose grappling and mating adapter will be designed and built to allow the positioner and even a robotic manipulator to handle the crawler.

- ***Portable Control Console***

A portable control console, similar to the one prototyped in Phase I, will be developed to provide for a minimal and rugged interface for day-to-day operations of the entire system.

• **Site Demonstration**

- ***Permitting, Site Training & Compliance***

A few weeks will be spent preparing and all relevant permits and NEPA information for submittal to local, state, federal and DoE-site officials for allowance of the DoE field test site. Necessary training for the field test team and other needed education, etc. will be accomplished during that period of time.

- ***Logistics Setup and Transportation***

The logistics needed for the site field test will be planned out between CMU and the selected DoE site. These will include site-access, deployment location, on-site power, support personnel, field test logistics, etc.

- ***Site Setup and Training***

A detailed plan will be drafted and submitted to the DoE site for evaluation. The plan will include every detail of on-site deployment, setup and the necessary operator training to deploy, operate and maintain the *BOA* robot system.

- ***Site Field Test and Cleanup***

We will assist in the setup and execution of the abatement field test at the selected DoE site. In addition we will be assisting in the demobilization of the entire system upon conclusion of the field test.

Overall, this phase is considered heavy on application-specific studies, engineering design, detailing, system integration and demonstration efforts. Again procurement, fabrication, assembly, testing, and demonstration are the follow-on activities that produce a demonstration of the integrated system operating on a mock-up pipe network at CMU and at a DoE site.

6.3 Success Criteria - Phase II

The integrated system will be considered a success, if we are able to demonstrate at the conclusion of Phase II, that the crawler and the human operator are able to easily and productively work together removing and bagging asbestos. The enhanced crawler should be able to successfully deal with specific pipe sizes and prevalent insulation types (no chicken-wire), and the manual work positioner (or the robotic manipulator) should be able to handle and position the crawler around obstacles such as valves, bends (whether vertical up/down or horizontal left/right) and junctions. We will demonstrate the robotically assisted approach with a deployment off the floor or a DoE-supplied work platform. Bagging and sealing the removed insulation and placing it on the floor should be achieved successfully and repetitively. Being able to grasp and remove the crawler from one section of pipe and placing it on a different section, should also be successfully demonstrated, and easy to perform by a trained operator. Use of an integrated control console should clearly show the transparency of control of two systems (off-board logistics unit and the crawler) working in unison, without overloading the operator nor affecting the theoretically achievable productivity of the removal system. The overall removal rate of the system will be measured and we should be able to at least match, if not exceed, the removal rate of a human operator performing the same task, which has been identified to us to be about 1 linear foot per hour (to be corroborated by the study). The entire system should be built to comply with all applicable EPA and OSHA regulations, so that the identified commercial partner interested in the commercialization of the system would be able to pursue certification through those agencies. We intend to involve the EPA and OSHA in the study, design, review and demonstration process.

We will consider the development a success, if we meet the internal milestones of design completion, and assembly in time to allow for two to three months of solid testing time, followed by a field test which proves all the claimed performance characteristics laid out for the system. Similar to Phase I, milestones where DoE sponsors will be invited to attend and give feedback as to successful completion, will be the design review, and the cold-test demonstration towards the end of this phase. Should interest persist within the DoE to pursue this system further, we will team up with an industrial partner, to propose follow-on phases for technology transfer and commercial system development phases to the DoE.

6.4 Task List - Phase II

- ***Task 2.1: National Environmental Policy Act Information***

The basic development and cold-test demonstration tasks laid out in the Phase II effort will not require the use of any current DoE facilities nor US government properties, and does in no way or form involve itself with the use of any product or process which could have any effect on air quality, water resources, land use, nor waste management. Ecological and socioeconomic impacts will not be felt, nor will occupational health and safety of the people directly involved nor the general public be jeopardized nor threatened.

Once a particular DoE-site expresses interest in having the system field tested at one of their own facilities, we do not anticipate requiring any further permits beyond those that the site already holds. We would however engage in such a task early enough in this phase, should it become clear that a DoE site field test has been approved and a site selected.

- ***Task 2.2: Project Kickoff Meeting @METC***

The program will commence with a meeting between CMU project team members, the commercial partner, as well as DoE personnel. During this meeting, the project schedule, objectives, and work plan will be reviewed; lines of communication and responsibility will be established; and DoE personnel will be identified for further involvement in the program activities.

- ***Task 2.3: Project Initiation***

A complete project team will be identified, briefed on technical scope, schedule, and budget, and areas of responsibility will be determined for each team member. Contractual issues will be finalized, and project cost and schedule tracking systems will be initiated for the duration of this phase.

- ***Task 2.4: Systems Approach Analysis***

This task will involve four different yet connected activities, surrounding (i) a regulatory analysis, (ii) site evaluation, (iii) robotic vs. human abatement comparison, and (iv) a cost/benefit analysis. In this task, we will perform the following activities:

- **Sub-Task 2.4.1: Regulatory Analysis (OSHA, EPA, DoE)**

We intend to review the standing EPA and OSHA regulations to see what the currently mandated work-practices are for human asbestos abatement operations. In addition we will compare these to the standing regulations that DoE site-contractors adhere to when they are performing the same tasks on DoE facilities. Furthermore we will identify and involve key people within the EPA and OSHA organizations to comment on the current, and participate in the future developments of the *BOA* system (research and enforcement).

- **Sub-Task 2.4.2: Site Evaluation**

We will undertake a set of site visits to Fernald and Oak Ridge and confer with Hanford and Savannah River over the phone, to get a clearer picture of their current mileage, status and types of L&I piping based on existing information. We will corroborate and expand said information at Fernald and Oak Ridge and in addition identify a field test site at both and make a recommendation as to where the system should be field tested to be as realistic and representative of the DoE complex as possible.

- **Sub-Task 2.4.3: Comparison of Robotic vs. Human Abatement**

An overall comparison between human and robotic performance will be drawn based on data gathered from commercial and DoE abatement contractors. We will visit Fernald and Oak Ridge to corroborate these numbers, and we will train our team to perform our own baseline abatement numbers. Market Study (within and outside of DoE)

The marketability of the *BOA* system will be explored in terms of its potential and allowable pricing for equipment and servicing for not only DoE but also commercial applications. This information will allow us to single out appropriate pipe size and types to make the system as widely usable under certain cost criteria.

- **Sub-Task 2.4.4: Cost/Benefit Analysis (targeted at DoE deployment only)**

A cost/benefit study will be undertaken to incorporate all site information, cost and insulation figures to determine what the most cost-effective area and system design should be pursued in order to maximize the ROI or operational costs within the DoE complex as

well as in the commercial setting.

- ***Task 2.5: Study Presentation***

The results of the study will be drafted, sent to the standing *BOA* review committee for comment, and then presented in a coherent fashion at a design review set up at CMU. The intention will be to summarize the key results and outline their effect on the overall design and present a conceptual drawing of the envisioned design. We would expect to fine-tune our design based on the committee's input and proceed with the detailed engineering design tasks.

- ***Task 2.6: Engineering Design***

This task will involve five different yet connected activities, surrounding (i) design enhancements to the existing crawler, (ii) design of an integrated off-board support and logistics unit, (iii) specification or design, and acquisition of a manual work positioner and the interface to the crawler, (iv) redesign and refinement of a portable control console, and (v) the design of an automated bagging system and its interface to the crawler. In this task, we will:

- **Sub-Task 2.6.1: Crawler Enhancements**

Design and detail the crawler system to allow fully electric operation, specific-pipe diameter and lagging type operations, ease of manufacture and other improvements based on the experimental results from Phase I.

- **Sub-Task 2.6.2: Automated Bagging System**

Design or specify a continuous bagging system for the removed lagging and insulation. Also detail the interfaces to the crawler, to the supply system (for poly-bags) and the approach of handling and removing the waste stream away from the crawler.

- **Sub-Task 2.6.3: Manual Work Positioner and Interface**

Specify and acquire an OEM device to manually emplace the crawler onto the pipe from a platform shooting-boom vehicle. In addition, design the male and female portions of a grasping fixture on the crawler and the positioner's endeffector to allow for grasping and handling of the same.

- **Sub-Task 2.6.4: Off-board support and Logistics Unit**

Design and detail the off-board system comprised of the computing system, power units, HEPA filter system, wetant/encapsulant fluid supply, video and control panels.

- **Sub-Task 2.6.5: Portable Control Console**

Re-design and detail a simple and functional control console with the required capabilities for system monitoring and control based on the experimental results from Phase I.

- ***Task 2.7: Design Review***

A review of the completed system designs will be conducted, including all CMU project team members, commercial partner and relevant DoE personnel. The design will include definition of all major components, their general locations and powering/control interconnections, overall dimensions, and rough estimates of the crawler's and deployment systems' weight and power requirements. A copy of the design presentation will be completed and distributed prior to the review, and will be used as a guide for presenting the design. Areas requiring further enhancement or definition to the design will be determined from the review and immediately addressed to avoid any conflicts with the implementation and integration schedules.

- ***Task 2.8: Procurement of long-lead items***

At the conclusion of the customer design review, we will seek authorization from the review committee and the CO at METC to go ahead and procure the long-lead items. The design will be advanced enough at that point in time, where these purchases are firm and avoid a delay in the implementation schedule.

- ***Task 2.9: Design Drawings Generation***

At the conclusion of the customer design review, we will begin the creation of all detailed custom and modified components of the system, in order to release them to fabrication as soon as possible after internal review.

- **Task 2.10: Design Drawings Release**
All drawings will be checked for accuracy and completeness and tolerances to allow easy assembly and economize on the fabrication cost.
- **Task 2.11: Software Development and Integration**
This task will involve the generation of software code based on the software architecture developed during Phase I and slightly modified based on the experimental and operator interface experiments at the conclusion of Phase I.
- **Task 2.12: Fabrication and Assembly**
This task will involve the fabrication of all custom and modified OEM components. We will also track all parts in the shops and frequently interface with suppliers to ensure on-time delivery of the properly ordered component(s). As components are delivered, we will begin functional assemblies to check for proper sizes, fits and functions of all mechanical, electrical and fluid systems.
- **Task 2.13: System Integration & Testing**
This task will involve the detailed integration issues (mechanical/electric/software) to bring together the individual system components into a single integrated and mutually cooperative device. In this task we will fabricate and assemble all sub-components and integrate them into sub-assemblies and eventually the complete system. All crawler, bagging, support and handling systems will be assembled separately and tested. A major task will also be the extension of the pipe mock-up built in Phase I. The individual sub-tasks are hence:
 - **Sub-Task 2.13.1: Overall System Integration**
Integrate all crawler subsystems (locomotor, remover, bagging unit, sensors, etc.), support systems (computing, power, HEPA, fluids, etc.), and handling systems (grappling fixture, manual positioner) and test them separately and as a progressively integrated system.
 - **Sub-Task 2.13.2: Mock-up Pipe Network Extension**
Extend the pipe network mock-up from the previous program phase to higher-reach heights and include more pipe length and more parallel pipe runs and obstacles.
- **Task 2.14: Review and Demonstration @ CMU**
A demonstration will be held at the offerors' facilities. Various modes of operation will be demonstrated to the DoE. In this task we will test and debug the system and get reliability to allow for flawless system operation before the actual demonstration. We will also demonstrate complete system functionality and operational scenarios of the complete integrated system. Demos of the scenario of system setup, installation, operation, insulation removal and handling, emplacement and removal of crawler onto/from diverse pipe diameters materials and locations, and overall operational simplicity and capability will be given. We will show the crawler being handled around various obstacles such as valves, bends and junctions, and illustrate the insulation bagging, placement and subsequent handling, including possible local operator assistance and supervision activities. All demonstrations will be conducted with fiberglass insulation on the pipe-mock-up network.
- **Task 2.15: Field Test**
This task will involve the drafting and submission of all regulatory paperwork to allow for the transition of the BOA prototype for a field test at a selected DoE site. Activities will include permitting, personnel training, site logistics, setup, testing and demobilization logistics. The individual sub-tasks are hence:
 - **Sub-Task 2.15.1: Permitting, Site Training & Compliance**
A few weeks will be spent preparing and all relevant permits and NEPA information for submittal to local, state, federal and DoE-site officials for allowance of the DoE site-demo. Necessary training for the field test team and other needed education, etc. will be accomplished during that period of time.
 - **Sub-Task 2.15.2: Logistics Setup and Transportation**
The logistics needed for the site demonstration will be planned out between CMU and the selected DoE site. These will include site-access, deployment location, on-site power,

support personnel, field test logistics, etc.

- Sub-Task 2.15.3: Site Setup and Training

A detailed plan will be drafted and submitted to the DoE site for evaluation. The plan will include every detail of on-site deployment, setup and the necessary operator training to deploy, operate and maintain the *BOA* robot system.

- Sub-Task 2.15.4: Site Field Test and Cleanup

We will assist in the setup and execution of the abatement field test at the selected DoE site. In addition we will be assisting in the demobilization of the entire system upon conclusion of the field test.

● ***Task 2.16: Project Management***

Throughout the duration of the project, the project manager will be responsible for assuring that team members comply with the schedule. Regular meetings will provide opportunities for the project manager to monitor team member activities and make any adjustments deemed necessary. Control of the financial aspects of the project will also be the responsibility of the project manager. Reporting requirements as laid out in the ROA will also be fulfilled as part of this task. In this task, we will hold weekly meetings to assess progress and chart new directions.

The activities that are part of this task, include:

- Review the state of the project
- Discuss and assign any technical problems to proper personnel for resolution
- Review the budget at the first meeting of every month. The review will include a check to ensure that spending matches expected spending for the work completed to date.
- Maintain projections of expenditures for the upcoming months.
- Prepare and disseminate required reporting documents to DoE.

6.5 Deliverables

The prototype system consisting of the external pipe crawler, the off-board logistics support unit, the work positioner and the portable control console, will be demonstrated to the DoE at our facilities and at another selected DoE site, such as Fernald or Oak Ridge (under separate DOE funding), at the conclusion of this second phase. At the conclusion of the site field test, all aforementioned hardware will be left at the DoE site and become property of the Department of Energy to use as they see fit.

The offeror will also comply with the Contract Reporting Requirements Checklist supplied in contract No. DE-AR21-93MC30362.

7.0 Appendix A: Experimental Apparatus - Photographs

A complete and labelled set of digitized hardware pictures is attached in this appendix. A video of the system and its abatement process can be obtained from CMU at a nominal cost. A brief description of the appended photographs is given below.

• BOA Test Setup

The test setup shows the entire system (excluding the hydraulic power supply and the HEPA vacuum) in the CMU test site. Notice the pipe mock-up, the control console and the control rack and the tether connected to the robot. In this picture we are in the process of removing insulation and lagging in the horizontal position.

• BOA Prototype Robot

The BOA prototype robot shown clamped to a horizontal pipe. Notice the individual components of the robot as well as the vacuum shell.

• BOA Close-Up

The close-up of the robot internals reveals details about the clamper and the paddling/cutting mechanism. The details of the articulation of these off the front/rear c-gears are also apparent.

• BOA Control Rack

The control rack shows the individual components of the off-board controller hardware, including the power conditioning rack, the computing rack, the valve controller racks, the servo-valve drawer and the top-mounted VCR and video display. The electric/hydraulic/fluid tether connects the rack to the robot.

• BOA Control Console

The control console is shown to be a portable unit with a touch-screen, a joystick and an emergency kill-switch. The entire robot system is controlled off this console, which the operator is intended to be wearing during the abatement operation.

• BOA Abated Materials

This picture shows the before and after for different types of lagging materials on fiberglass insulation simulant material. The purpose is to show the successful removal of the insulation and lagging and the deformation (despite relaxation) that the material experienced after the compression and ejection cycles.

BOA Test-Setup

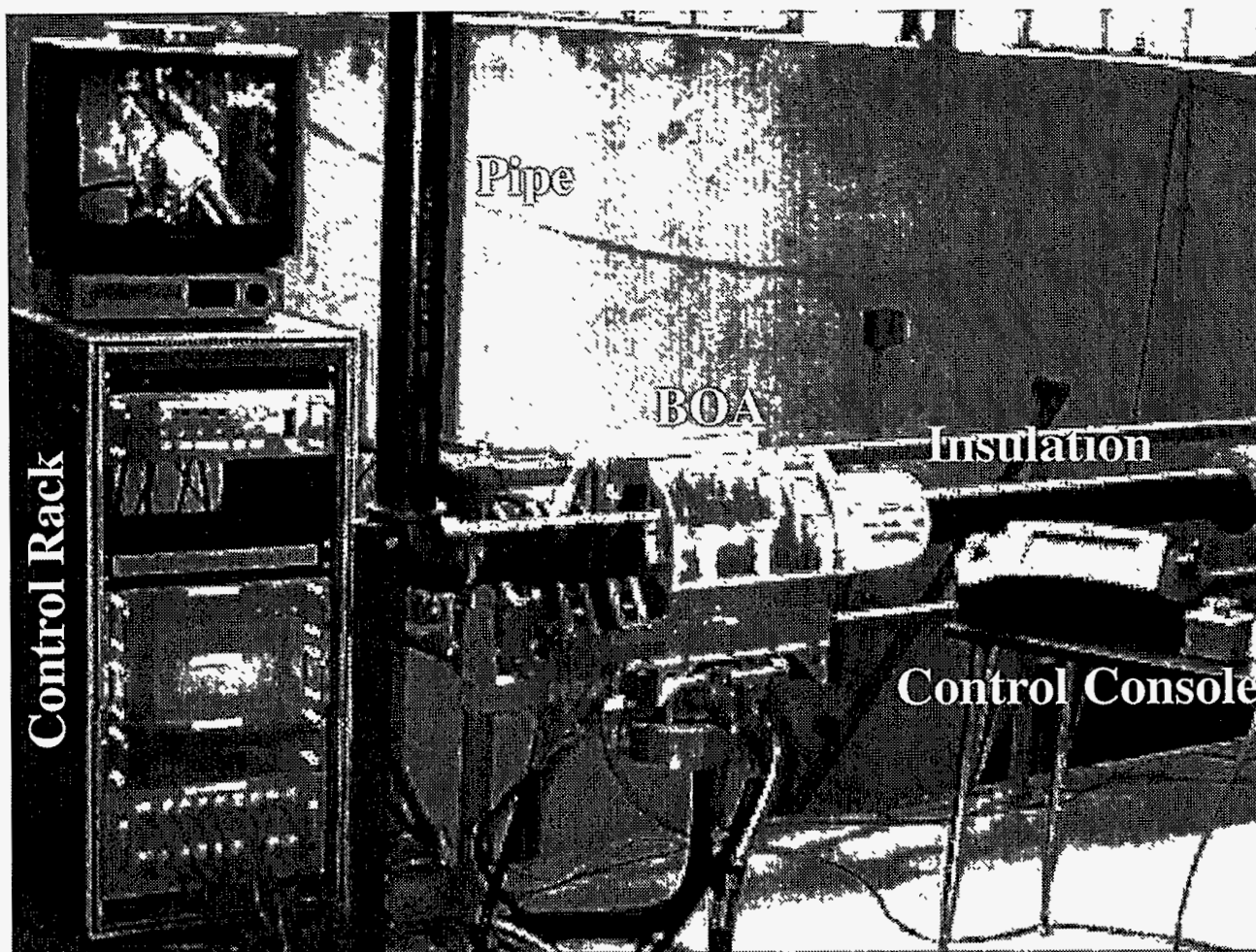

BOA Prototype Robot

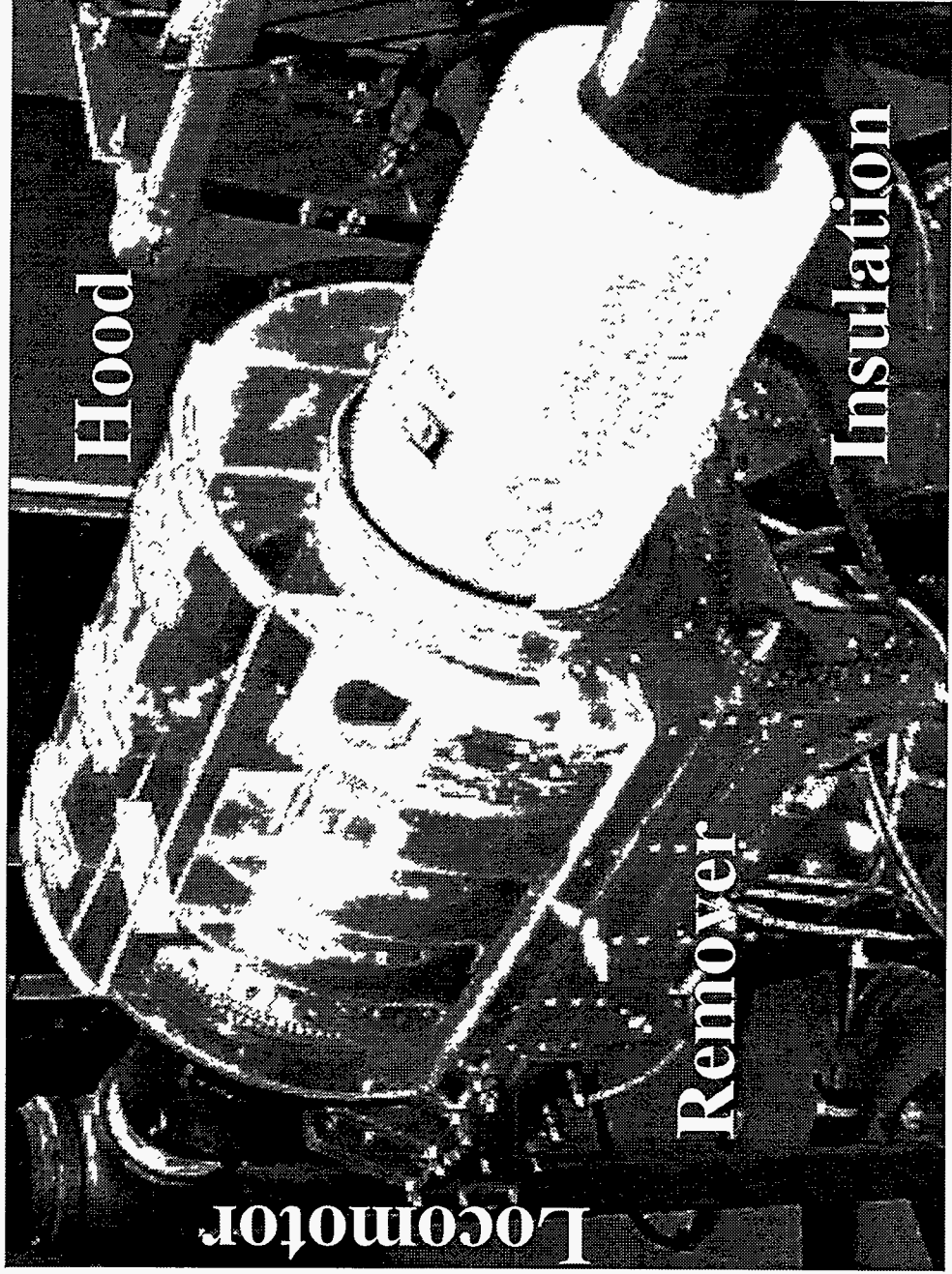

BOA Close-up

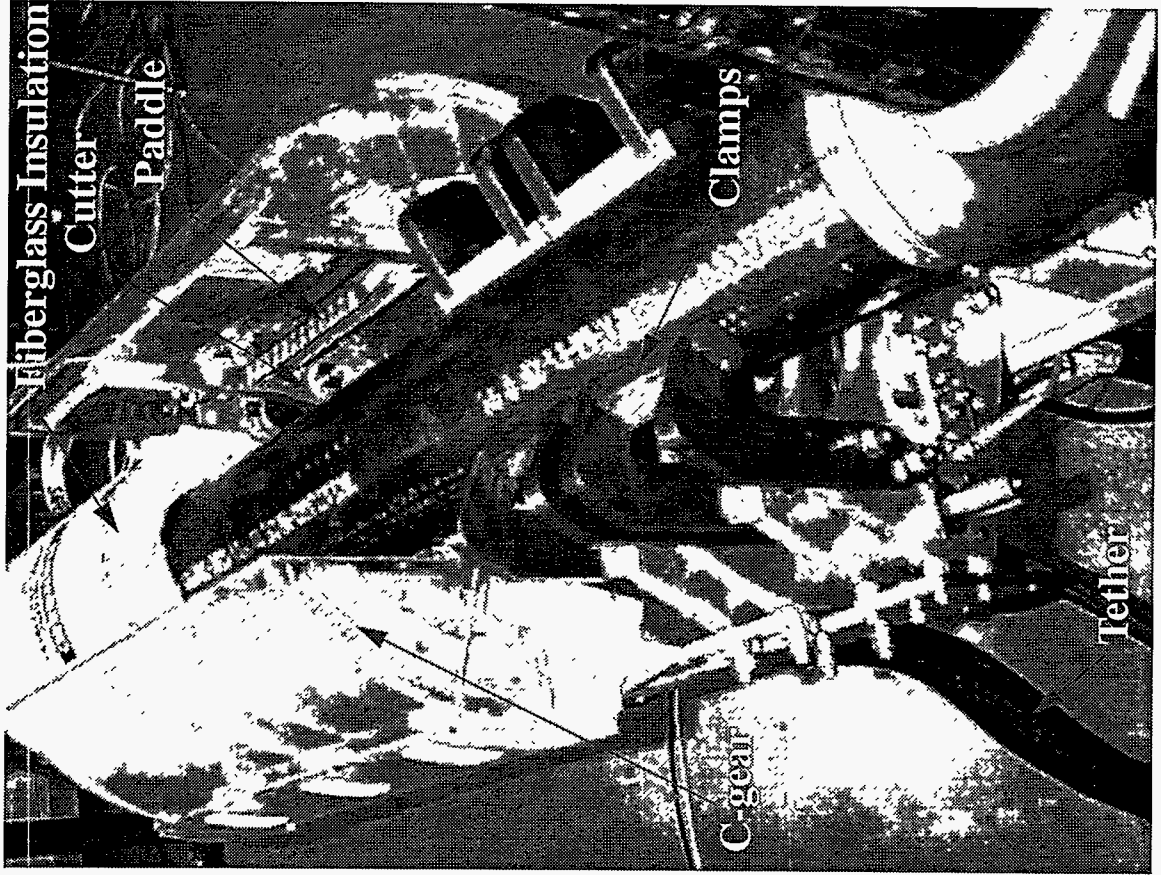

BOA Control Rack

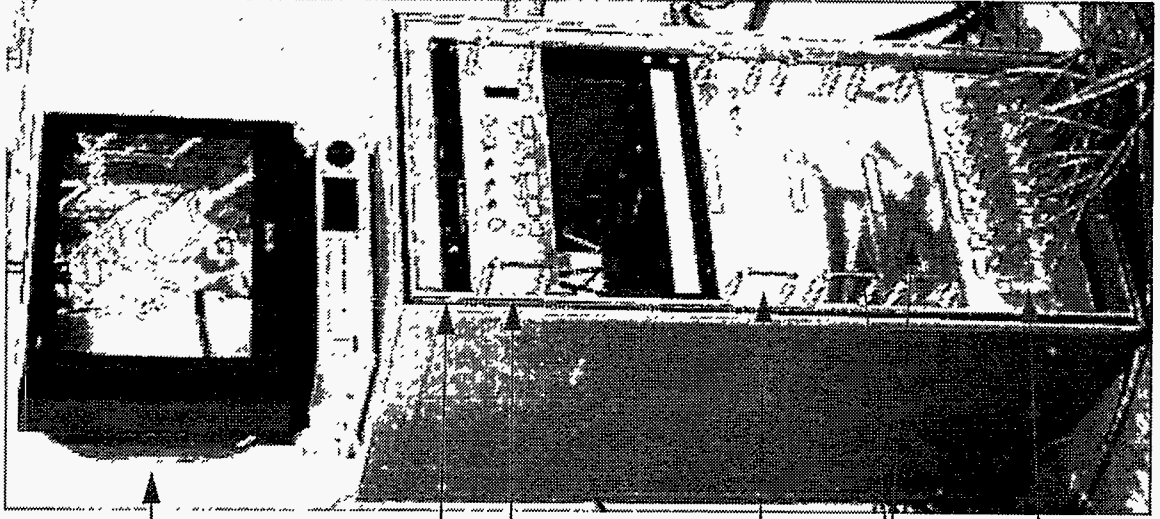

Video Monitor

**Cutter Power-Supply
Power Switching
Enclosure**

Computing Enclosure

**Hydraulic Controller
Enclosures**

**Hydraulic Valves
Enclosure**

BOA Control Console

Touchscreen

TV Monitor

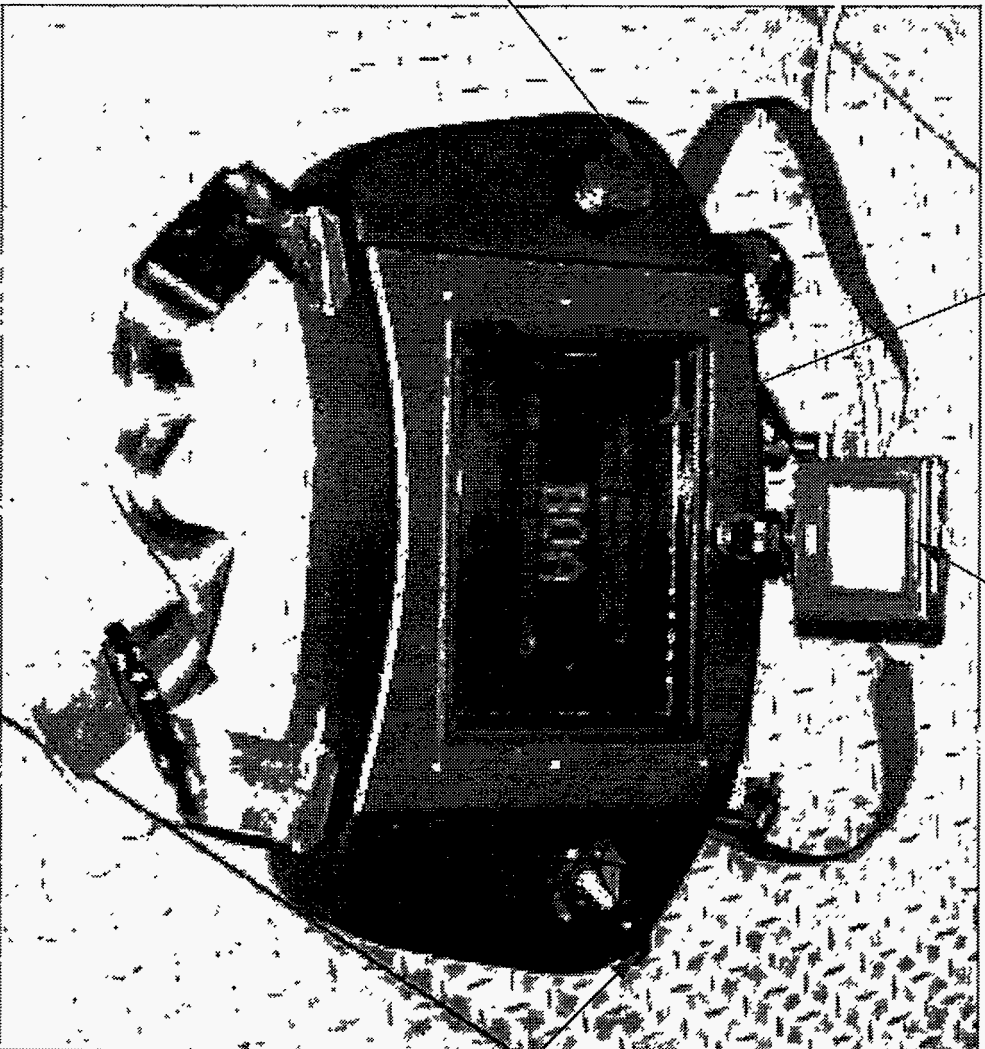

E-Stop

Joystick

BOA Abated Materials



Cut pieces of paper, aluminum & chicken-wire clad fiberglass insulation

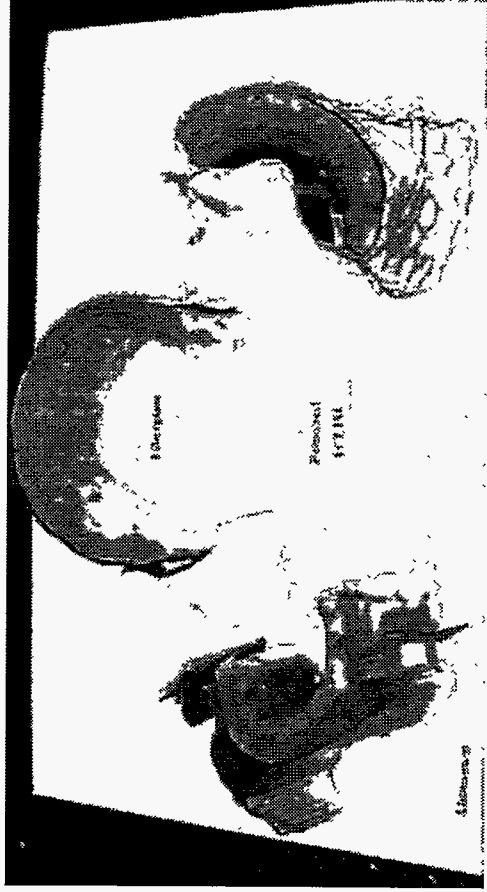

Removed sections of paper, aluminum & chicken-wire clad fiberglass

8.0 Appendix B: Experimental List

A sample of the individual experiments carried out during this phase are included in this appendix for completeness sake. The results were distilled from the data gathered during the performance of the experiments and are summarized in Section 3.5.2: Summary of Results on page 33.

The individual experiments and the goals of the experiment are included here for completeness sake, while only the detailed experimental data sheet for the locomotor functionality test has been included as an example:

•Locomotor Functionality Test

We need to determine the difference between as-built and designed system parameters to insure we can fit onto the pipe (given the variability in OD), locomote and remove insulation. We also need additional data to compute the accurate productivity of the system in feet/ per hour. The effects of a wet pipe and operating in a vertical configuration needs to be studied. A secondary motivation for the required hydraulic pressure experiments will be to obtain data to possibly modify the unit to operate with electrical actuators, which requires knowledge about gripping forces.

•Remover Functionality Test

We need to determine the proper functionality of all individual and combined remover subsystems. Operation of the c-gears under different loads must be ascertained to insure no binding nor interference at the teeth nor bearing surfaces. Operation of the paddles must be controlled and repeatable and not cause any interference with the c-gears nor the cutter-wheel. The operation of the cutter motor must be within tolerable audio and vibration levels and not generate excessive heat that can not be properly dissipated. The actuation of the cutter-cylinder should cause the desired cutting depth as per design.

•Vacuum Hood Functionality Test

We wish to determine the proper functionality of the vacuum hood and the vacuuming system under realistic test conditions such as a bare pipe and an insulated section of pipe. All stationary seams covered with brush seals are to be perfect seals or cause an in-flow of air to avoid release of particles to the outside. All dynamic seals such as along the cleared pipe and the insulated pipe should also be perfect or have an inward airflow, despite the presence of encapsulant and different insulation and lagging materials.

•Wetting Agent/Encapsulant Spray System Functionality Test

We want to make sure that the encapsulant system has the proper coverage and operational characteristics in the face of different insulation types, orientation on a pipe (horiz. vs. vert.), location of insulation within the remover section, etc. We hope to determine the optimal configuration by adjusting the nozzle type, rotational carrier speed, etc. Of importance will also be to minimize effluent encapsulant flow by dripage, while maximizing the absorption of the encapsulant into the insulation.

•Overall System Performance Test - No Lagging

The goal of this experiment is to test the entire system performance under benign conditions, namely insulation without lagging. We will want to monitor all parts of the mechanized abatement procedure, and determine key performance parameters, such as operating temperature, insulation behavior and -weight, abatement cycle time, etc. We hope to establish a performance baseline and validate our abatement approach. The baseline will be optimized and then applied to the more demanding abatement operations which involve lagging and operations on vertical piping.

- **Overall System Performance Test - Vertical**

The goal of this experiment is to test the entire system performance in a vertical abatement situation. The goals are hence the same as in the NO-LAGGING experiment, except that we will be more interested in the behavior of the encapsulant in terms of absorption into the insulation being removed, and effluent streams from drippage or flow along the pipe.

- **Overall System Performance Test - Aluminum Lagging**

The goal of this experiment is to test the entire system performance under more stringent conditions, where aluminum lagging is covering the insulation. Similar to the NO LAGGING experiment, we are interested in all the basic parameters, but re placing emphasis on such issues as cutter motor jamming, feed-rates, and operating temperature, encapsulant absorption and effluent volume(s), paddle dig-in and compression behaviors of the L&I material as well as the ejection behavior. The main interest here is to ensure that since we expect higher forces during this type of abatement, that the machine can handle the loads and that the lagging does not cause any other unforeseen problems. We want to establish a performance figure for this situation and further validate our abatement approach. We will also look into the effects of operating on vertical piping.

- **Overall System Performance Test - Chicken Wire**

The goal of this experiment is to test the entire system performance under more stringent conditions, where chicken-wire lagging is covering the insulation. Similar to the ALUMINUM LAGGING experiment, we are interested in all the basic parameters, and are placing emphasis on such issues as cutter motor jamming, feed-rates, and operating temperature, encapsulant absorption and effluent volume(s), paddle dig-in and compression behaviors of the L&I material as well as the ejection behavior. The main interest here is to ensure that since we expect higher forces during this type of abatement, that the machine can handle the loads and that the lagging does not cause any other unforeseen problems. We want to establish a performance figure for this situation and further validate our abatement approach.

- **Regulatory Compliance - Air Monitoring**

The goal is to determine how close our current system comes to the established levels of allowable fiber-counts in abatement operations. We intend to test the system during a normal operational cycle over a fixed period of time performing abatement operations, while monitoring a variety of different location along static and dynamic seals and the environment around the sealed off abatement area. The measurements (average and maximum values) will be compared to the ambient fiber count before the experiment was started. The entire monitoring and laboratory work will be performed by an outside contractor certified by the EPA and OSHA. Our data will be used to extrapolate our performance over an 8-hour work-shift and guide us in improving the system in the next phase.

- **Regulatory Compliance - Pipe Cleanliness**

We want to determine how clean we can get the pipe using (i) just the paddles, (ii) scrapers attached to the backs of the paddles, and (iii) a separate wire-brush system to clean the pipe. Since we can only simulate the 'bake-on' phenomenon (accomplished using solvent-based glue), we will attempt to remove all attached fiber particles so that a clean pipe can be guaranteed, whether we wet-scrape/brush or dry scrape/brush the pipe. We will try to determine the best approach to pass the 'white-glove' test, and make recommendations for future approaches to succeed.

EXPERIMENT TITLE: Locomotor Functionality Test

EXPERIMENT GOAL(S): We need to determine the difference between as-built and designed system parameters to insure we can fit onto the pipe (given the variability in OD), locomote and remove insulation. We also need additional data to compute the accurate productivity of the system in feet/ per hour. The effects of a wet pipe and operating in a vertical configuration needs to be studied. A secondary motivation for the required hydraulic pressure experiments will be to obtain data to possibly modify the unit to operate with electrical actuators, which requires knowledge about gripping forces.

EXPERIMENTAL DATA TO BE COLLECTED: Clamper open and closed dimensions

Measure length and repeatability of locomotor stroke

Measure system sag under overhung load of remover (i.e. pipe-gap)

Measure slippage of clamper at different HPU pressures

EXPERIMENTAL MEASURING EQUIPMENT: Ruler, Dial-calipers, micrometer, stop-watch

EXPERIMENTAL SUCCESS CRITERIA:

As-built dimensions of clamper (open/closed) and locomotor stroke to within 5% of design goal. Repeatability to within 1% of full stroke. MUST fit over and onto a 4" nominal pipe (up to 4.5" O.D.).

System sag must not cause settling or interference between any part of the system and the pipe and/or insulation.

Slippage pressure to be determined to lie within pressure rating of HPU variability (+/-5% of current pressure), irrespective of wet or dry surface conditions. Calculation of clamping force to be used for site and design information.

EXPERIMENTS TO BE COVERED: 1.4, 2.1

DATE OF TEST: 11/7/94

SET-UP PROCEDURE:

1. Turn on HPU, set pressure at 3000 psig with low flow
2. Check for system leaks and fix any that are found
3. Bleed air from locomotor clamp & stroke cylinders and hydraulic lines
4. Place BOA on hydraulic lift platform with rear clamp suspended to allow motion
5. Cycle locomotor clamp and stroke cylinders several times to verify proper motion

TEST PLAN:

1. Drive front clamp to open. Measure corner-to-corner distance between the top pads 7.703 [in] using vernier calipers. (1.4.1.1)
2. Drive front clamp to closed. Measure distance between the centers of the three pads a) 3.729, b) 3.400, c) 3.360 [in] using vernier calipers. (1.4.1.1)
3. Repeat steps 1 and 2 twice each to check repeatability of results. Repeatability was averaged to lie within +/-.010 [in].
4. Drive rear clamp to open. Measure corner-to-corner distance between the top pads 7.824 [in] using vernier calipers. (1.4.1.1)
5. Drive rear clamp to closed. Measure distance between the centers of the three pads a) 3.768, b) 3.402, c) 3.457 [in] using vernier calipers. (1.4.1.1)
6. Repeat steps 4 and 5 twice each to check repeatability of results. Repeatability was averaged to lie within +/-.010 [in].
7. Extend stroke cylinder. Measure distance between pads 1.641 [in]. (1.4.2)
8. Retract stroke cylinder. Measure distance between pads .143 [in]. (1.4.2)
9. Repeat steps 7 and 8 twice each to check repeatability of results using dial gage or vernier calipers. Repeatability measured and averaged to lie within +/-.001 [in].
10. Clamp BOA onto dry horizontal pipe in bottom position. Mark starting position on the pipe, and have stopwatch ready.
11. Step BOA through 3 complete stroke/clamp cycles. Record avg. speed .03 [ft./min]. (1.4.3, 2.1.1)
12. Repeat step 11. Record and compute results .03 [ft./min]. (1.4.3, 2.1.1)
13. Repeat step 11. Record and compute results .03 [ft./min]. (1.4.3, 2.1.1)
14. Compute average: averaged to be .03 [ft./min].
15. Repeat step 11 with BOA on a vertical pipe. Record average speed .03 [ft./min.] (1.4.3, 2.1.1).
16. Repeat step 15. Record and compute results .03 [ft./min]. (1.4.3, 2.1.1)
17. Repeat step 15. Record and compute results .03 [ft./min]. (1.4.3, 2.1.1)
18. Compute average: averaged to be .03 [ft./min].
19. Clamp BOA onto horizontal pipe at 90 degrees from bottom resting position.
20. With BOA at 90 degrees from bottom position, gradually reduce line pressure until circumferential slippage occurs. Record results. 2000 [psig]. (2.1.2)
21. Repeat step 21. Record results. 2000 [psig]. (2.1.2)
22. Repeat step 21. Record results. 2000 [psig]. (2.1.2)
23. Compute average pressure 2000 [psig], and resultant pipe contact force 285 [lbs] (based on kinematics equations).
24. Repeat step 21 on wet pipe. Record results. 2000 [psig]. (2.1.2)
25. Repeat step 21. Record results. 2000 [psig]. (2.1.2)
26. Compute average pressure 2000 [psig], and resultant pipe contact force 285 [lbs].
27. Clamp BOA onto vertical pipe.
28. Step locomotor forward and backwards two (2) steps each to check system rigidity under overhung load conditions. (1.4.1.2). Measure the sag of the front of the unit during each step (relative to when the unit is clamped and stationary pipe) .150 [in] using a ruler. Monitor if the clamping of the front clamp recenters the unit on the pipe after this sag. yes/no

29. Gradually reduce line pressure until slippage occurs. Record results. 2000 [psig]. (2.1.2)
30. Repeat step 30. Record results. 2000 [psig]. (2.1.2)
31. Repeat step 30. Record results. 2000 [psig]. (2.1.2)
32. Compute average pressure 2000 [psig], and resultant pipe contact force 285 [lbs].
33. Repeat step 30 on wet pipe. Record results. 2000 [psig]. (2.1.2)
34. Repeat step 30. Record results. 2000 [psig]. (2.1.2)
35. Repeat step 30. Record results. 2000 [psig]. (2.1.2)
36. Compute average pressure 2000 [psig], and resultant pipe contact force 285 [lbs] (based on kinematics equations).

OBSERVATIONS:

2000 psi. min. for no slip, 2500 psi. = very safe. Spikes on side pads of front clamp causes BOA to walk off pipe, but spikes are needed in vert. walk on front clamps to prevent slippage. Solution: put spikes on bottom shoes of front and rear clamp. 1 step sag =.150", 10 step cumulative sag =.165".

CONCLUSIONS:

See summary of results