

ANL/CMT-ACL/CP-94051

RESULTS OF PILOT IMPLEMENTATION STUDIES OF DOE'S  
INTEGRATED PERFORMANCE EVALUATION PROGRAM (IPEP)\*

P. C. Lindahl, W. E. Streets, J. J. Marr, K. J. Parish, A. E. Scandora, Jr.

Analytical Chemistry Laboratory  
Chemical Technology Division  
Argonne National Laboratory

RECEIVED  
JUL 01 1999  
OSTJ

G. A. Anast  
Environmental Assessment Division  
Argonne National Laboratory  
Argonne, IL 60439

W. R. Newberry  
U.S. Department of Energy  
Office of Environmental Management  
Washington, DC 20585

J. R. Dahlgran  
U.S. Department of Energy  
Radiological and Environmental Sciences Laboratory  
Idaho Falls, ID 83415

C. Watkins and J. Connolly  
Idaho National Engineering and Environmental Laboratory  
Idaho Falls, ID 83415

J. Fisk  
U.S. Environmental Protection Agency  
Washington, DC 20460

to be presented at  
37<sup>th</sup> ORNL-DOE Conference  
on Analytical Chemistry in Energy Technology  
October 7-9, 1997  
Gatlinburg, TN

The submitted manuscript has been created by the University of Chicago as Operator of Argonne National Laboratory ("Argonne") under Contract No. W-31-109-ENG-38 with the U.S. Department of Energy. The U.S. Government retains for itself, and others acting on its behalf, a paid-up, nonexclusive, irrevocable worldwide license in said article to reproduce, prepare derivative works, distribute copies to the public, and perform publicly and display publicly, by or on behalf of the Government.

\*Work supported by the U.S. Department of Energy under Contract W-31-109-ENG-38.

## **DISCLAIMER**

**This report was prepared as an account of work sponsored by an agency of the United States Government. Neither the United States Government nor any agency thereof, nor any of their employees, make any warranty, express or implied, or assumes any legal liability or responsibility for the accuracy, completeness, or usefulness of any information, apparatus, product, or process disclosed, or represents that its use would not infringe privately owned rights. Reference herein to any specific commercial product, process, or service by trade name, trademark, manufacturer, or otherwise does not necessarily constitute or imply its endorsement, recommendation, or favoring by the United States Government or any agency thereof. The views and opinions of authors expressed herein do not necessarily state or reflect those of the United States Government or any agency thereof.**

## **DISCLAIMER**

**Portions of this document may be illegible in electronic image products. Images are produced from the best available original document.**

# **Results of Implementation Pilot Studies of DOE's Integrated Performance Evaluation Program (IPEP)\***

---

**37th ORNL-DOE Conference on  
Analytical Chemistry in Energy Technology  
Gatlinburg, TN  
October 7-9, 1997**

\* Work supported by the U.S. Department of Energy under Contract W-31-109-ENG-38.

# Co-contributors

---

P.C. Lindahl, W.E. Streets, J.J. Marr, K.J. Parish, G.A. Anast, and A.E. Scandora, Jr.  
Analytical Chemistry Laboratory  
Argonne National Laboratory  
Argonne, IL 60439

W.R. Newberry  
U.S. Department of Energy  
Office of Environmental Management  
Washington, DC 20585

J.R. Dahlgran  
U.S. Department of Energy  
Radiological and Environmental Sciences Laboratory  
Idaho Falls, ID 83415

C. Watkins and J. Connolly  
Idaho National Engineering Laboratory  
Idaho Falls, ID 83415

J. Fisk  
U.S. Environmental Protection Agency  
Washington, DC 20460

# Objectives of Pilot Studies

---

## SMO Objectives:

- Access laboratory performance information quickly, in useful formats
- Have meaningful, consistent assessments of laboratory performance

## IPEP Objectives:

- Provide laboratory performance information to various user audiences quickly, in useful formats for each users needs
- *Develop a system for providing information to the various IPEP user audiences*

# Types of IPEP Reports

PEPROG/ QUARTER	CLP INORG	CLP ORG	WS	WP	EML QAP	MAPEP	PESP
FY93 Q2	<i>FY93 Q2</i>	<i>FY93 Q2</i>		030			
FY93 Q3	<i>FY93 Q3</i>	<i>FY93 Q3</i>	032		39		
FY93 Q4	<i>FY93 Q4</i>	<i>FY93 Q4</i>		031			
FY94 Q1	<i>FY94 Q1</i>	<i>FY94 Q1</i>	033		40		
FY94 Q2	<i>FY94 Q2</i>	<i>FY94 Q2</i>		032		S1	
FY94 Q3	<i>FY94 Q3</i>	<i>FY94 Q3</i>	034		41	W1	
FY94 Q4	<i>FY94 Q4</i>	<i>FY94 Q4</i>		033		S2	
FY95 Q1	<i>FY95 Q1</i>	<i>FY95 Q1</i>	035		42	W2	<i>AF: GA, B</i> <i>Water: Gamma</i>

Consolidated Reports

WS035  
Single Study  
Report \*

EML QAP  
Single Study  
Report\*

WP033  
Single Study  
Report\*

\* Single Study Reports include historical studies.

# IPEP Report Production Process

---

- Acquiring information about laboratories & services being provided to EM & PE Program participation
- Acquiring data from PE Programs
- Providing reports to user audiences



# Acquiring Information about Laboratories

---

1. Identify laboratories providing services to EM
2. Identify type of service each laboratory provides to EM  
**OPS Offices, SMOs → LAB DB**
3. Match laboratory EM services to PE program participation
4. Summarize laboratory services, PE participation  
**LAB DB → IPEP → Various PE programs**
5. Query apparent lapses in PE program participation  
**IPEP → OPS Offices, SMOs**
6. Initiate participation in appropriate PE programs  
**OPS Offices, SMOs → Laboratories**
7. Return to Step One

# Integrated Performance Evaluation Program

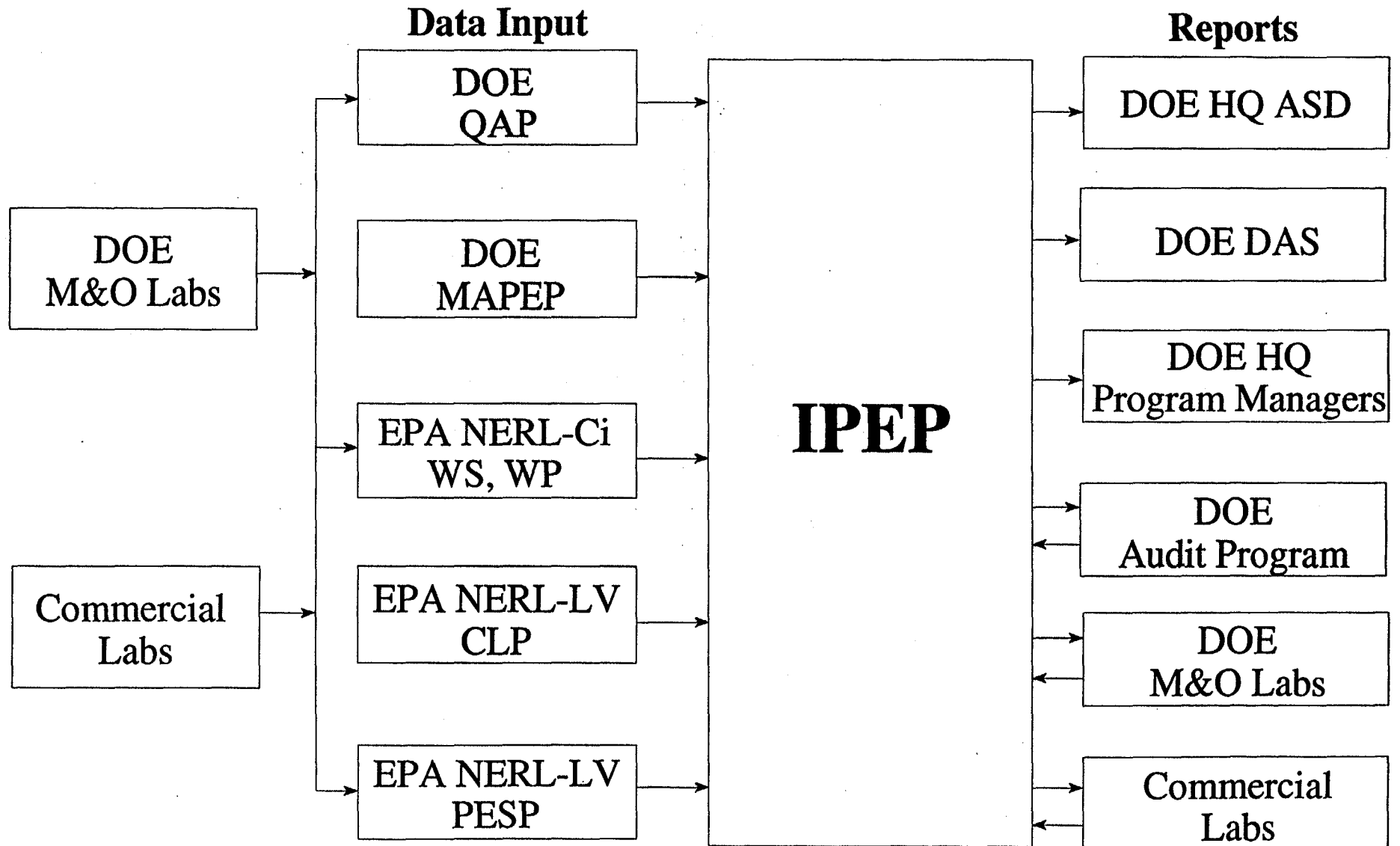

# Providing Reports to SMOs, OPS Offices

---

- Hard Copies
- Electronic versions of reports, via Internet
- ☼ Electronic transmission of data to SMOs, OPS Offices in formats compatible for incorporation into local assessment systems

# IPEP Reports

---

- IPEP Objectives
  - Normalize assessments in all reports
  - Support assessments with Corrective Action Protocols
  - Produce all reports in similar formats

*to facilitate*

  - Ease of use by the End Users
  - Subsequent incorporation of information into Consolidated & Management Reports

# Corrective Action Philosophy for Single Study Reports

---

- Be reactive enough to be effective for EM needs,
- ... *But* not over-reactive to the detriment of budget or professional relationships
- Attempt to use one system for all reports for consistency & simplicity to end users
- Identify real, acute, problems in current studies
  - Problems with the same analyte in more than 1 matrix
  - Problems with several analytes in the same matrix
- Use historical data to identify chronic problems
- ☼ Bias not yet incorporated into Corrective Action Protocols

# Formats for Hard Copy Single Study Reports are designed to be progressive in level of detail

---

- **Introduction:**
  - Specify particular study
  - Detail any problems or anomalies reported by PE Program Sponsor
- **Summaries (Tables & Graphs):**
  - Overall, Matrix/Analyte Class
- **Individual Laboratory Reports (Current & Historical Information):**
  - Individual Laboratory Summary Report (ILSR)
  - Laboratory Individual Analyte Summary Report
- **Appendix:**
  - Brief Individual PE Program Description
  - Explanation of scoring algorithms, assessments

# Individual Laboratory Summary Reports (ILSRs)

---

## Formats for WS & WP

- Overall Summary of Performance in Current Study
- & Summary by Matrix/Analyte Class for:
  - % Participation
  - % Acceptable
  - IPEP Assessment
- Identification of Unacceptable Analytes in Current Study
- Recommended Areas for Corrective Action, with Reasons Specified

# Internet Versions of Reports

---

- Currently WS, WP, & QAP posted
- No Summaries
- No Corrective Actions
- False Positives correctly incorporated into all reports
- Able to use both graphical and non-graphical browsers



# Laboratory Individual Analyte Summary Report Formats:

---

## **WS & WP:**

- Same as Sponsor Format for Current Study

## **WP:**

- Two water samples are treated as different matrices
- Oil is not summarized separately
- False Positives not incorporated

## **QAP:**

- Individual analyte results have been arranged to present data the same as other PE Program Sponsors

## **All:**

- IPEP Assessments
- Historical data for previous three studies

# Operational Issues to Resolve

---

1. Permission to access & publish PE data
2. Provision of PE data in local formats for electronic download into local assessment systems
3. Corrective Action:
  - Who informs laboratories?
  - Who initiates follow-up?
4. Others??