

## Development of the Low Return Loss 340-Size Ceramic Window for the APS Linac

S. Berg, D. Bromberek, G. Goepfner, A. Haase\*

J. Hoyt, W. Michalek, T. Smith,

*Advanced Photon Source, Argonne National Laboratory, Argonne, IL 60439, U.S.A.*

*Phone: (630) 252-2916, Fax: (630) 252-8342*

*E-mail: sberg@aps.anl.gov*

*\*Stanford Linear Accelerator, Stanford University, Stanford CA 94309 U.S.A.*

*Phone: (650) 926-8612, Fax: (650) 926-4974*

*E-mail: aah@SLAC.Stanford.EDU*

### Abstract

The Advanced Photon Source (APS) linac high-power switching system makes use of 340-size waveguide components. These components include vacuum-grade furnace-brazed transitions, pressurized-grade aluminum 340-size switches, and more recently 340-size ceramic windows. The fabrication of these 340-size windows proceeded with brazing of ceramic membrane to thin-walled copper sleeves and real-time network analyzer testing performed by the ASD (Accelerator Systems Division) RF (Radio Frequency) Group. Initially it was thought that this real-time testing of prototype hardware would be necessary in the investigative stage to establish the required dimensions and physical geometry to satisfy the 40-dB return-loss criteria. However, producing four windows now installed involved real-time network analyzer testing during production of each window conducted in parallel with adjustments of tuners designed into each 340-size ceramic window.

**Keywords:** radio frequency, vacuum, brazing

### 1. Introduction

The Advanced Photon Source (APS) is a high-brightness, third-generation light source user facility. The waveguide switching/distribution system installed in the APS linac klystron gallery currently provides a hot spare for half of the S-band transmitters [1] of the APS linac required for normal storage ring injection operations. Although L3 was originally used to drive the sixth 2856-MHz accelerating structure located immediately downstream of the positron conversion target, the change from positron to electron operation in the APS storage ring changed the line configuration by eliminating from the linac this sixth accelerating structure. Accordingly, L3 has adopted the role of hot spare for L2 and for L1. Through the waveguide switching/distribution system, L3 also supplies rf power to the photocathode gun at the front end of the linac. For normal storage ring injection operation, L1, L2, L4, and L5 are operated, and for the SASE-FEL studies that require the photocathode gun, all five klystrons are operated [2]. A sixth klystron L6 has been installed in the linac gallery and may become a hot spare for L4 and L5 but currently serves as a high-power test stand for the pressurized 340-size switches and windows being modified and fabricated at the APS [3]. Figure 1 shows one such switching subsystem installed in the gallery above L2 comprising these components. The 340-size waveguide leads from L3 at a 15°4' elevation and is directed to either the L2 sled or to an additional subsystem above L1 through the use of 340-size switches and a 340-size waveguide. To join both the L2 SLED (SLAC Energy Development) and L2 to this subsystem, wire

electrical discharge machined tapered transition pieces are used to make the size transition from rectangular 284-size copper waveguide to rectangular 340-size copper waveguide. At the L2 subsystem, two 340-size switches facilitate the waveguide switching. Tests at L6 by the Accelerator Systems Division (ASD) RF Group indicate these 340-size switches handle greater than 40 MW at the 2856-MHz rf operating frequency whereas 284-size switches safely handle less power. In addition, the larger 340-size waveguide supports the rf signal more efficiently and with less loss over long distances of the overhead run. Because the 340-size switches are pressurized with SF<sub>6</sub> at 28 to 32 psig, the RF Group indicated the need for 340-size windows to separate the pressurized SF<sub>6</sub> from the vacuum ( $10^{-9}$  Torr) maintained in the 284-size waveguide. A low return loss criteria of 40-dB for this new window was established by the RF Group, and the ASD Vacuum Group worked closely with the RF Group in the initial investigative stage of window development and in production of four installed windows to date. The 340-size windows manufactured to meet this return loss criteria could in theory be installed wherever desired in series without degrading overall performance of the distribution system and can be installed to further separate the distribution system into maintainable isolated zones.

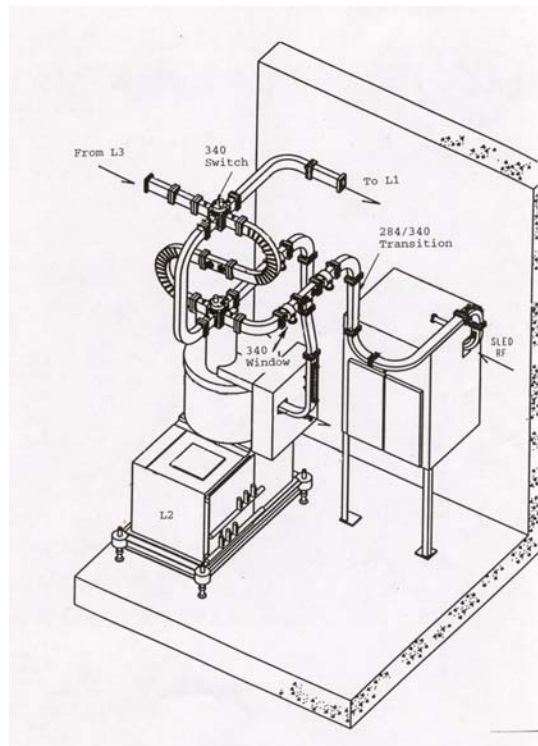

Figure 1: Waveguide switching system.



Figure 2: Ceramic brazing technique.

## 2. Standard Pill Box Design with Slip-Fit Plungers

Some discussion of the standard pillbox design for waveguide windows long used at SLAC follows. Figure 2 shows the technique used to achieve a vacuum-tight braze between the metalized edge of a 0.15"-thick 3.99" diameter alumina disk and a thin-walled (0.04") copper

sleeve, where a fixture supports the ceramic disk and the shrink-fit copper sleeve is heated on a hot plate and then slipped over the ceramic. The shrink-fitted copper sleeve in turn is tied with

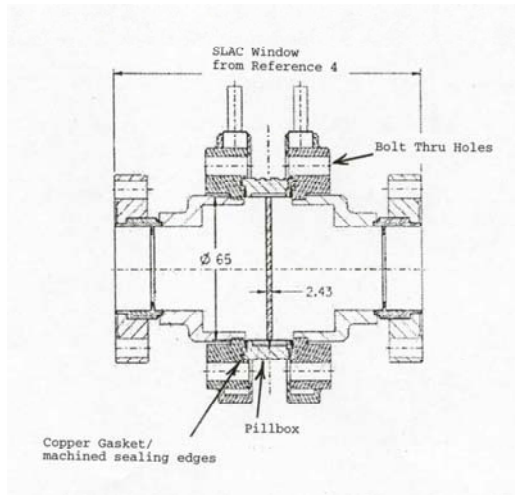

Figure 3: Pillbox style window.

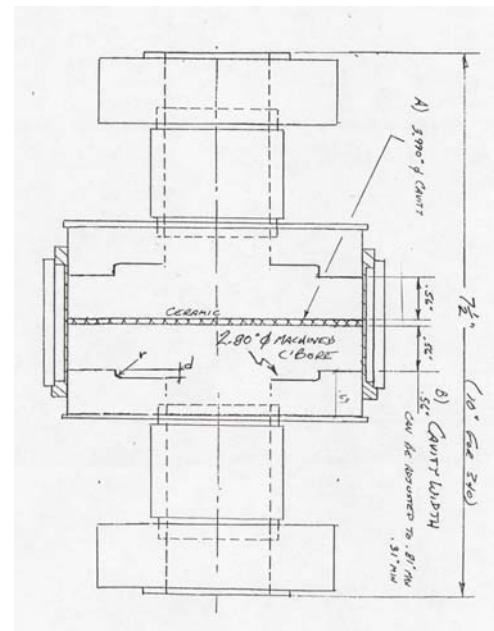

Figure 4: Initial investigative hardware.

annealed molybdenum wire to prevent the thin wall from unacceptably expanding from the ceramic during the braze cycle. The copper sleeve/ceramic sub-assembly is slipped into a reinforcing stainless ring to which it is also brazed. This ceramic brazing technique is largely the same as that has been used at SLAC. The result is a ceramic window center (pillbox), which is circular in cross section. This is the style window eventually arrived at, with the serviceable circular pillbox sandwiched between two similar ends. In the 340-size window developed at the APS these two ends are a rectangular male crush seal flange end and a rectangular female crush seal flange end. We refer to this three-piece construction as the standard pillbox design. Taken from a discussion [4] regarding high power window development for X-Band where double irises cancel the unwanted TE<sub>02</sub> mode, Figure 3 shows how this style window at SLAC is assembled by means of two copper gaskets. Each copper gasket mates a sealing edge of circular outline machined into the stainless steel pillbox ring with a sealing edge of circular outline machined into the mating end piece. On each side of the pillbox this union is established in removable fashion with bolts that insert through each end piece. Coincidentally, the investigative stage of the APS 340 window program necessitated a crude initial hardware unit that also was a three-piece construction. This initial hardware was not vacuum-tight brazed and was used rather like a double slide trombone to investigate the gap size on each side of the ceramic (i.e., cavity size) to establish the dimensional geometry necessary to achieve better than 40-dB measured return loss. The initial adjustable hardware consisted of a modified pillbox that was machined to receive a plunger style end in slip fit fashion from either side.

### **3. Adjustable Plungers Achieve better than 40-dB Return Loss.**

Using the initial hardware on a low-power rf test bench, it was learned that the return loss is extremely sensitive to the position of the plungers into the pillbox (cavity width), which defines the cavity volume on either side of the ceramic. Using shims and a threaded rod fixture that assisted in finer adjustment, the plungers and cavities were adjusted and measured with a network analyzer on a low-power test bench by the RF Group to have achieved greater than 40-dB return loss. This is better than any window available today commercially in the more common 284-size, yet alone 340-size. Although shims and the crude fixture (not shown) made finding the correct cavity match difficult, this achievement demonstrated that a 340-size window with greater than 40-dB return loss given the 3.990” diameter ceramic and 2.80” diameter machined plunger counter-bore could be achieved (Figure 4). The transition from a crude investigative unit of hardware to a vacuum-tight unit ready for high-power testing and installation was the next step. One remaining question was, “Is there reason to believe that extreme control of fabrication tolerances and absence of adjustability will lead to 40-dB consistently in production?” A pillbox manufactured at SLAC was inspected, and the mean distance from ceramic face 1 to machined sealing edge 1 (cavity width) differed by only 0.0005” compared to the mean distance from ceramic face 2 to machined sealing edge 2. On each side of the ceramic, the standard deviation of this distance was only 0.00025”. Considering that remaining question, SLAC manufacturing tolerances of vacuum tight pillboxes are viewed by the ASD Vacuum Group to be a standard that needs no improvement, but the typical SLAC window is approved for installation at 32-dB, not 40-dB. A 40-dB return loss is not a SLAC necessary criteria. SLAC personnel indicate that a challenging window program at SLAC has as a design goal the improvement of power-handling capability rather than return loss. SLAC has in the past utilized copper gaskets of varying thickness to achieve return loss tuning of 32-dB or better for certain S-band windows. The ASD Vacuum Group had to weigh the process at SLAC that produces such impressive manufacturing tolerances, and yet is not known to have regularly produced a 40-dB return loss or better, against the success of the adjustable plunger model in Figure 4. We decided at that time to further develop the adjustable pillbox and plunger style.

### **4. TIG Welded Pillbox Design with Plungers, Knife Edges, Cavity Tuners**

The status of a pillbox that has its sealing edges machined and that does not meet the return loss requirement once it is assembled with copper gaskets can be uncertain when engineers ask what should be done to improve the return loss. Should thinner or thicker copper gaskets be used? Should the sealing edge (edges) be remachined? Whether or not the cavity volumes are minutely too small or too large and by how much are difficult questions to answer. The answers can more quickly come on a test bench in real time if the design allows for adjustability of either cavity volume in minute increments. Since sealing edges are needed to render the standard pillbox design a unit ready for rf bench testing, we sought a solution where the position of the plunger face relative to the ‘sealing edges’ is not rigidly fabricated until after the initial rf bench testing and investigation into cavity adjustment is complete. The crude hardware shown in Figure 4 evolved into the hardware shown in Figure 5. With the TIG (tungsten-inert-gas)-welded adjustable design, the plungers are adjusted into the center assembly (pillbox). After the rf engineer is satisfied with his electrical measurements/cavity

volumes, using a network analyzer, the plungers are TIG-welded at the location shown in Figure 5. Essentially, the adjustable plunger that slip-fits into the pillbox sleeve is not yet TIG-welded to its 6 3/4" Conflat until after rf bench testing. The three-piece vacuum-tight assembly is achieved by means of one 6 3/4" Conflat TIG-welded to each end-piece (following low-power bench testing/adjustment) and two 6 3/4" Conflats TIG-welded to the pillbox (prior to all low-

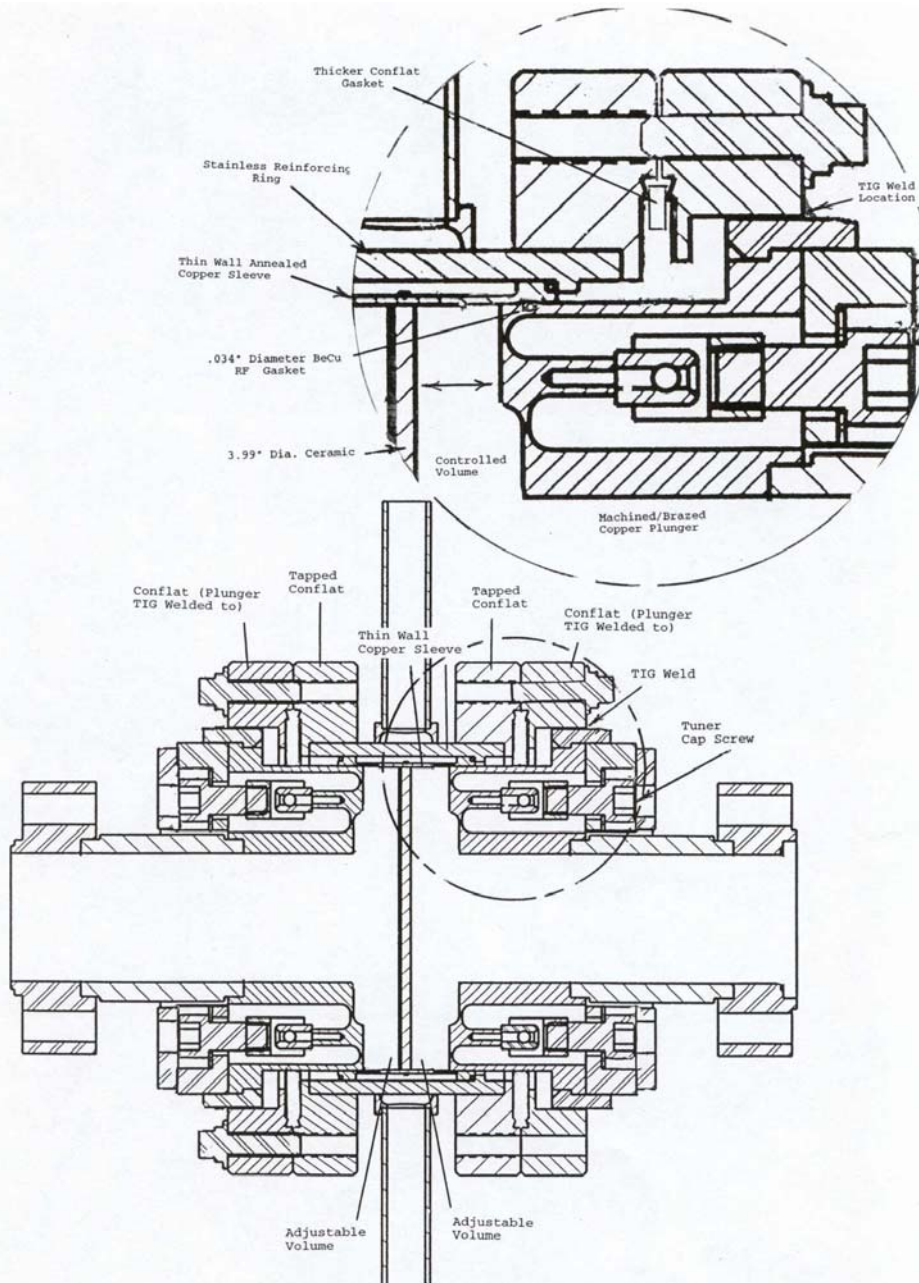

Figure 5: Sectional view of 340 window.

power bench testing/adjustment). While this eliminates the need to machine/remachine sealing edges, the TIG welding has the effect of departing from the ideal 40-dB (or better) benchmark established on the test bench. It was originally hoped that TIG welding would produce a consistent volume change in one direction, probably decreased.

Figure 5 shows why the TIG-weld location is thought to cause the plunger to be pulled toward the ceramic. However, this paper does not ignore available measurement data, including electrical, that indicates plunger movement after the TIG weld can also be away from the ceramic. Physical plunger movement was measured by a coordinate measuring machine on three points per plunger of two assembled windows using the TIG-welded outer stainless collar as a reference. From this sparse data, the actual plunger face movement internal to the window is best reported as not exceeding 0.005" and not less than 0.0005". Following are the methods used to bring the unit back to the 40-dB benchmark following the TIG weld. Most frequently, the tuner cap screws (Figure 5) are turned clockwise, pulling the plunger face to increase volume. The tuner cap screws are viewed by the RF Group to be indispensable. In three units, the unit was disassembled following TIG welding and a Conflat gasket 0.010" thicker (being 0.010" thicker than the standard 0.084") than the gasket prior to the TIG weld was inserted. The Conflat bolts and thicker gaskets can be regarded as tuners, not unlike what SLAC has done in the past. One difference is that the commercially available 6 3/4" Conflat knife edges are more acute and higher profile than are the relatively flat SLAC machined sealing edges. In this way, increased Conflat bolt torque on a copper Conflat gasket can offer a way to approach variable degrees of decreasing volume, and, if employed following the insertion of a 0.010" thicker gasket, can be used to approach a minute volume increase following the TIG weld. Dimensional variations from thicker gaskets and various adjustments yield a completed 340-size window length that is within 0.030" of the nominal 10" length. Figure 6 shows a completed reduced-weight version window with one plunger removed. Figure 7 shows a unit that has been TIG welded. Shown attached to the unit is the removable adjustable fixture, which evolved from earlier designs, which is used to adjust the plungers into the sleeve in preparation for TIG welding. One fixture on each end of the pillbox allows individual plunger adjustment prior to TIG welding.

## **5. High-Power Testing**

To date four 340-size windows with greater than 40-dB return loss have been high-power tested at the L6 test stand to 42 MW and 4.5 microsecond pulse at 2856 MHz. The ASD RF Group indicates that the test level is limited by the 45-MW klystron recently installed at L6 and that the typical peak power limit of this window is unknown until further testing is pursued with higher power klystrons, possibly at SLAC. A one time test to date with the first production unit indicated that the return loss measurements on the low power test bench were unchanged following high power testing; but, return loss has not yet been measured while the window is subjected to vacuum and pressurized SF<sub>6</sub> and cooling jacket water flow. The ceramics are coated at SLAC on each side with TiN<sub>2</sub> measured at 15 Å by Rutherford back scattering analysis and have tested consistently with no sign of multipactor or breakdown. Yet, severe arcing persisted at the sleeve/plunger slip-fit until BeCu rf gaskets of a spiral design and 0.034" diameter were installed. This is also shown in Figure 5.

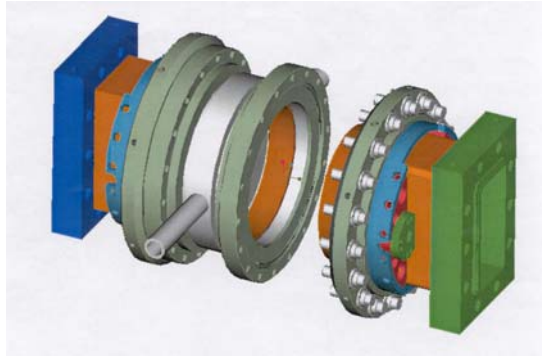

Figure 6: Disassembled 340 window.

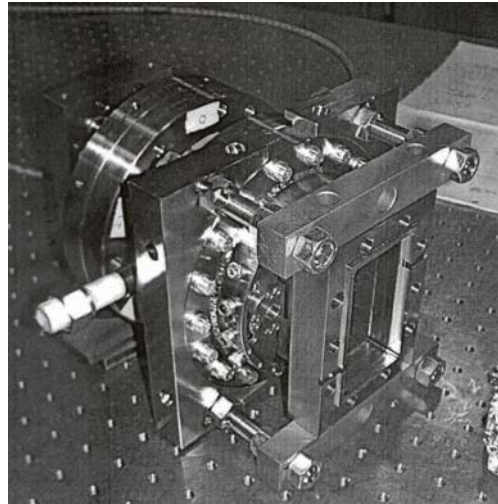

Figure 7: Weld fixture.

## 6. Conclusions

During this program the ASD RF Group secured hardware and designed a setup that enabled measurement with repeatable results of return losses greater than 40-dB. This paper describes one course taken, but invites additional hardware approaches. A different route may be one where the TIG-weld fixture is discarded. Perhaps if one of the TIG welded and 40-dB units is disassembled and measured internally using a coordinate measuring machine to determine plunger penetration, then from these constraints a machined/brazed fabrication with 40-dB return loss or better may be possible. Simply, the SLAC fabrication tolerance for cavity width (0.0005" when the sealing edge is machined following ceramic braze) are tighter than the tolerances lost during the TIG weld (0.005"). Yet a question asked in Section 3 leads to another: "How confident can one be that the correct nominal dimension for cavity width is independent of variances in braze fillet, precise cavity roundness, and especially machined inconsistencies such as steps, counter-bores, 45-degree chamfers, so that the optimal nominal dimension for cavity width is known?" Successful units described herein make great use of slip-fit plunger/sleeve design, acute and high profile knife-edges to bite into the copper gaskets, and tuner cap screw tuner design. So, the TIG weld itself is one of the least expensive features. The most expensive feature is the plunger/ sleeve slip fit, and if that feature is pursued, then the TIG welding is cost efficient provided the loss in tolerance from welding is recoverable. The four inch diameter plunger/copper sleeve slip-fit can be within 0.001/0.002 inch diameter clearance if the plungers are initially slightly oversized and then turned to match the final inner diameter of the thin-walled annealed sleeve, which is bored slightly following brazing. If there is one feature that upon elimination would avoid difficult machining, it would be the slip-fit.

"Is the slip-fit necessary?" That may be the most important question. Smaller windows such as WR284 or X-band require smaller diameter sleeves, which may be more easily

controlled in roundness for the required plunger/sleeve slip-fit. Because of smaller diameter, tolerance lost in TIG welding may translate to a greater percentage of volume change for X-band. Perhaps with features described herein this too is recoverable, and perhaps a different welding technique, such as laser, or different welding procedure (process of tacking prior to welding) can be investigated. The ceramic brazing at this date has evolved into a dry hydrogen one-step braze where the stainless/copper/ceramic center is brazed in a single furnace run. Finally, measuring return loss on a unit while it is subjected to actual installation conditions of vacuum, SF6 pressure, and water jacket flow would be desirable.

## **7. Acknowledgments**

The authors thank J. Gagliano and Dan Van Lannen of the ASD Vacuum Group and ANL Central Shops, respectively, for their support and TIG welding; Mark Martens and Val Svirtun of the ASD Vacuum Group for their attention to detail in the cleaning and preparation of window components; Rich Callin of SLAC Light Fabrication for his instruction regarding ceramic brazing; George Gorski of ANL Central Shops for his machining expertise; Michael Douell of the ASD RF Group for assistance with the rf test bench; Dale Miller at SLAC for his work on coating ceramics; and Chris Pearson and Rich Atkinson at SLAC for their assistance with hydrogen brazing. This work was supported by the U.S. Department of Energy, Office of Basic Energy Sciences, under Contract No. W-31-109-ENG-38.

## **8. References**

- [1] A. E. Grelick, N. Arnold, S. Berg, Y. W. Kang, R. L. Kustom, A. Nassiri, J. Noonan and M. White, "A High Power S-Band Switching System for the Advanced Photon Source (APS) Linear Accelerator (LINAC)," Proceedings of the XIX International Linac Conference, Chicago, IL, pp. 914-916 (1998).
- [2] A. E. Grelick, N. Arnold, S. Berg, D. Dohan, G. Goepfner, Y. W. Kang, A. Nassiri, S. Pasky, G. Pile, T. Smith, S. J. Stein, "Testing and Implementation Progress on the Advanced Photon Source (APS) Linear Accelerator (LINAC) High Power S-Band Switching System," Proceedings of the XX International Linac Conference, Monterey, CA, pp. 983-985 (2000).
- [3] A. Nassiri, A. Grelick, R. L. Kustom and M. White, "High Peak Power Test of S-Band Waveguide Switches," Proceedings of the 1997 Particle Accelerator Conference, Vancouver, B.C., Canada, pp. 3174-3176 (1997).
- [4] W. R. Fowkes, R. S. Callin, E. N. Jongewaard, D. W. Sprehn, S. G. Tantawi, "Large Diameter Reduced Field TE01 Traveling Wave Window for X-Band," Proceedings of the 1999 Particle Accelerator Conference, New York, NY, pp. 783-785 (1999).