

Title: **THE PROTOTYPE FUNDAMENTAL POWER
COUPLER FOR THE SPALLATION NEUTRON
SOURCE SUPERCONDUCTING CAVITIES:
DESIGN AND INITIAL TEST RESULTS**

Author(s): K. M. Wilson, I. E. Campisi, E. F. Daly, G. K. Davis,
M. Drury, J. E. Henry, P. Kneisel, G. Myneni,
T. Powers, W. J. Schneider, M. Stirbet, Y. Kang,
K. Cummings and T. Hardek

Submitted to:

<http://lib-www.lanl.gov/cgi-bin/getfile?00796799.pdf>

THE PROTOTYPE FUNDAMENTAL POWER COUPLER FOR THE SPALLATION NEUTRON SOURCE SUPERCONDUCTING CAVITIES: DESIGN AND INITIAL TEST RESULTS*

K. M. Wilson[†], I. E. Campisi, E. F. Daly, G. K. Davis, M. Drury, J. E. Henry, P. Kneisel, G. Myneni, T. Powers, W. J. Schneider, M. Stirbet, TJNAF, Newport News, VA 23606, USA
Y. Kang, Spallation Neutron Source, Oak Ridge, TN 37830, USA
K. Cummings, T. Hardek, LANL, Los Alamos, NM 87545, USA

Abstract

Each of the 805 MHz superconducting cavities of the Spallation Neutron Source (SNS) is powered via a coaxial Fundamental Power Coupler (FPC) with a 50 Ω impedance and a warm planar alumina window.

The design is derived from the experience of other laboratories; in particular, a number of details are based on the coupler developed for the KEK B-Factory superconducting cavities. However, other design features have been modified to account for the fact that the SNS FPC will transfer a considerably lower average power than the KEK-B coupler.

Four prototypes have been manufactured so far, and preliminary tests performed on two of them at Los Alamos National Laboratory (LANL). During these tests, peak powers of over 700 kW were transferred through the couplers in the test stand designed and built for this purpose.

This paper gives details of the coupler design and of the results obtained from the RF tests on the test stand during the last few months. A more comprehensive set of tests is planned for the near future.

1 INTRODUCTION

The SNS makes use of superconducting RF cavities resonating at 805 MHz in the fundamental $TM_{010}-\pi$ mode to accelerate H^+ ions in the main linac from 185 MeV to the full final energy (840-1300 MeV) [1].

The superconducting cavities, under development at Jefferson Lab [2], must produce accelerating gradients consistent with peak surface electric fields of 27.5 MV/m, or better. In order to power the cavities, coaxial couplers were chosen. The couplers must be able to withstand at least the peak power delivered by the SNS klystrons (shown in Table 1), 550 kW for a 1.3-msec pulse length at a repetition rate of 60 pulses per seconds (pps).

A simple window geometry was chosen to facilitate manufacturing and assembly. The KEK-B couplers had reached close to 1 MW in CW during conditioning and close to 400 kW in operation [3]. To adapt that design to the SNS frequency, a geometrical scaling of the coupler's main dimensions with frequency was implemented. The FPC design is shown in Figure 1.

By this method, several properties would remain

invariant, including the impedance and the multipacting levels in the coaxial part of the FPC [4]. However, some of the constraints imposed by the cryomodule geometry and assembly procedures led to a number of significant design modifications.

Table 1: Coupler requirements

Parameter	Operation	Processing
Q_{ext}	about 7×10^5	NA
Impedance	50 Ω	
Peak power	550 kW	1 MW max
Pulse length	1.3 ms	1.3 + ms
Repetition rate	60 pps	60 pps max
Average power	48 kW	60 kW
Bias	± 2.5 kV	± 2.5 kV

To ensure that the FPCs will perform properly during linac operation, they must be processed with pulsed RF power at levels about twice the operating power level. A room-temperature test stand has been designed and built at Jefferson Lab for the characterization, testing and processing of the FPCs before they are assembled onto the superconducting cavities.

The test stand allows for simultaneous processing of two FPCs and has the following capabilities: 1) modularity, mobility and clean room compatibility; 2) *in situ* baking of the FPCs and of the ultrahigh vacuum (UHV) components; 3) monitoring of critical RF and vacuum parameters; 4) diagnostics and control equipment for baking and RF processing; 5) interface with data acquisition and retrieval systems.

This paper discusses the design characteristics of the SNS FPCs, design of the test stand, and the results of the initial testing.

2 FUNDAMENTAL POWER COUPLER DESIGN

2.1 Electrical and RF Design

The design of the SNS prototype FPCs relies on a 50 Ω coaxial line. The planar alumina window includes impedance-matching elements [3, 5] as well as TiN anti-multipacting coating (Figure 2). Modified Conflat[®] gaskets are used at the joint on the vacuum side of the

* Supported by US DOE Contract No. DE-AC05-00OR22725

[†]kwilson@jlab.org

window to provide good RF contact by minimizing the gap at the flange, and to achieve a UHV joint.

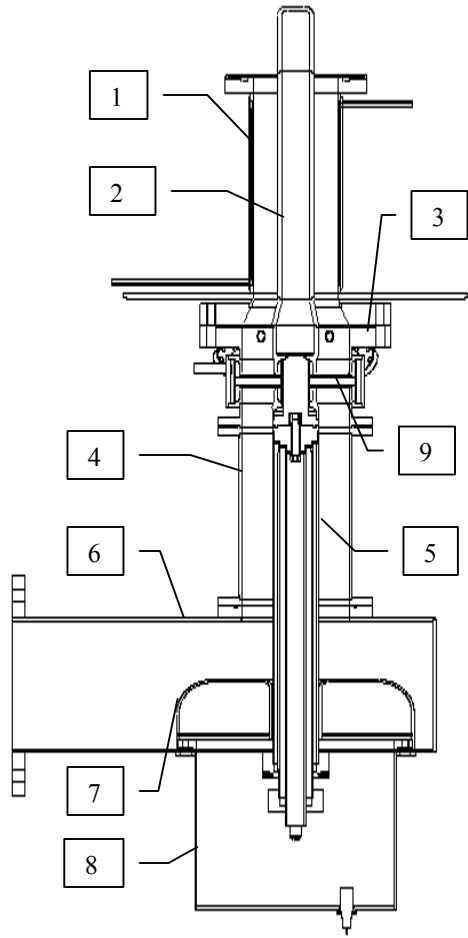

- | | |
|---------------------|---------------------|
| 1 – Outer Conductor | 2 – Inner Conductor |
| 3 – Window Assembly | 4 – Outer Extension |
| 5 – Inner Extension | 6 – Waveguide |
| 7 – Doorknob | 8 – Waveguide Cover |
| 9 – Ceramic Window | |

Figure 1: Fundamental Power Coupler

The transition between the WR975 waveguide from the klystron and the coaxial line of the FPC is provided by a doorknob configuration [4]. At the doorknob/inner extension interface, there is the possibility of biasing the inner extension via a capacitor between the doorknob and the inner conductor itself at d. c. voltages in the range of ± 2.5 kV.

Multipacting in the coaxial line and at the window can produce window limitations and failures. Extensive simulations have been performed to study the multipacting behavior of the FPC and the levels and locations have been predicted [4]. One critical parameter which the FPC must be able to meet is the Q_{ext} for the SNS superconducting cavities ($7.3\text{E-}5$ for medium and $7.0\text{E-}5$ for high β cavities). Again, extensive simulations and measurements have been performed and reported [4].

The Q_{ext} can vary due to the following reasons:

- The thermal contraction of the outer conductor and the thermal expansion of the inner conductor during full power operation (as much as 48 kW average power). This effect is estimated to alter the Q_{ext} by no more than 10%.
- Mechanical tolerances of the FPC's inner and outer conductors. These variations should alter the Q_{ext} by no more than 10%.
- Line mismatch in the window assembly and in the door knob transition. The total VSWR is estimated to be around 1.05, so the variation of Q_{ext} would amount to about 5%.
- Uneven field profile in the cavity. This effect is currently under study. Since few statistics are available, this effect is estimated to be around 40%.

The average RF dielectric losses in the window are estimated to be around 2 W, whereas the losses in the transmission line are 30 W in the inner and 3 W in the outer conductor, between the window and the FPC's tip. These losses can be handled by the cooling systems described in section 2.3.



Figure 2: Window and inner conductor (a) and outer conductor (b)

2.2 Mechanical Design

Once the FPC is fully installed on the cavity, it is expected to be subjected to minimal mechanical loads.

The weight of the extensions, waveguide, doorknob and cover is about 9 kg. This weight is primarily conveyed through the outer extension and conductor of the FPC to the cryomodule and thus does not stress the window. In addition, a bracket bolted to the outside of the cryomodule will be supporting some of the weight of the assembly.

The total thermal contraction of the outer conductor as it ranges from room temperature to 2 K is 0.4 mm. The FPC is designed so that the compliance in the bellows

between the coupler and the cryomodule will compensate for this deflection. Another load will be produced by the pressure of the atmosphere on the large flange of the outer conductor when the space inside the cryomodule is evacuated. Analysis shows that this force would cause only negligible stresses, 30 MPa in compression and 12 MPa in bending.

To verify that the coupler assembly is not excited by the macropulse repetition rate of the accelerator, which is 60 pps, a normal modes analysis of the assembly was performed. The calculated fundamental frequency of the FPC assembly is 97 Hz. The lowest mode found that is a multiple of 60 Hz is 720 Hz.

2.3 Thermal Design

To minimize heat transfer to the cavity beampipe, the FPC outer conductor is helium cooled. By design, the total heat load, including static and dynamic contributions, from the FPC to the 2K circuit must be less than 2 W. To handle these loads, a stream of 3 atm, 5 K supercritical helium with a flow rate of 0.038 g/s per FPC removes ~30 W of static and dynamic heating during normal operation. As shown in Figure 3, a heater-thermocouple control loop maintains the window at 300 K while the cold end operates at ~5K.

A single helical flow passage is machined into a thick-walled stainless steel tube. A thin-walled stainless steel tube is then shrunk-fit over the outer diameter of the flow passages and welded onto the ends nearest the flanges. The internal vacuum surface is copper plated with a nominal thickness of 15 μm (RRR \approx 10) to reduce resistive wall losses induced by the RF surface currents while minimally increasing the heat load to the 2 K circuit.

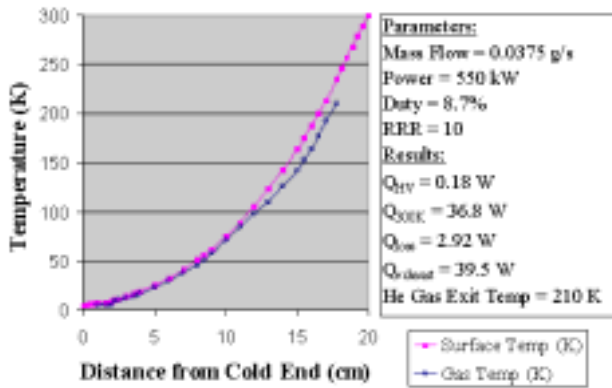

Figure 3: FPC outer conductor thermal profile

The inner extension is water cooled to remove heat from the inner conductor and reduce radiative heating of the cavity beam pipes. A system was designed in which water enters through the outer of three concentric tubes and exits through the middle tube (the inner tube being hollow and air filled). The stream of water passes near the window-inner extension interface and removes the heat deposited in the window and inner conductor, which is then conducted through the inner extension.

3 TEST STAND DESIGN

3.1 Mechanical Design

The test stand used for the RF processing of the FPCs includes a robust, mobile aluminum cart. The test stand cart is clean-room compatible and has adjustable feet, which allow the height of the FPCs to be altered to meet the requirements of the test situation. The test cart and associated components are shown in Figure 4.

The cart houses the vacuum system, the connecting waveguide and two SNS FPCs, a deionized-water-compatible cooling manifold for the inner conductor extensions, and instrumentation needed during baking or RF processing. For convenience, the FPCs are tested in an inverted orientation.

To allow for simultaneous RF conditioning and power testing of two SNS FPCs under UHV, each pair of FPCs is mounted in a connecting waveguide and operated in transmission from one coupler to the other.

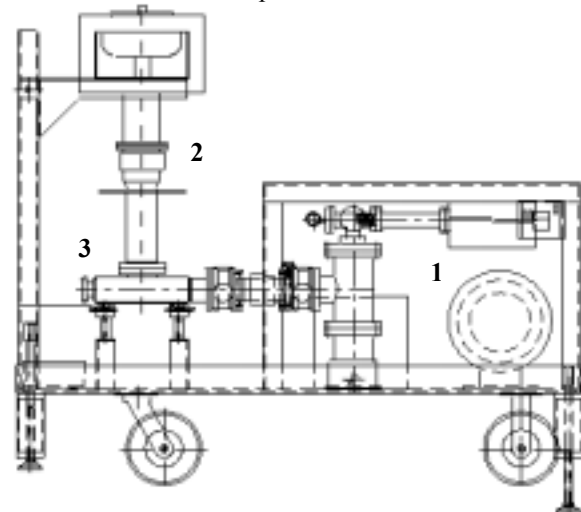

Figure 4: The FPC test cart includes a pumping unit (1) and a coupler pair (2) on a connecting waveguide (3).

3.2 Vacuum Layout

Preprocessing and RF conditioning of the couplers is performed under ultrahigh vacuum (better than 7×10^{-9} torr), and materials compatible with this requirement have been used. UHV is maintained using a turbomolecular pump, which is backed by a dry rough pump.

Vacuum pressure near the ceramic window is measured with inverted magnetron gauges. In addition, a compact, full-range vacuum gauge, a helium leak standard, and a residual gas analyzer are mounted on a manifold and connected to the connecting waveguide.

The vacuum system is compatible with baking at 200°C. After RF processing the couplers, the system can be backfilled with dry, dust-free nitrogen through a nanofilter which is installed on the connecting waveguide. Two couplers can then be stored under nitrogen on the connecting waveguide until they are required for installation onto the cavity.

3.3 Instrumentation and Controls

Baking of the FPCs prior to conditioning was performed using a Programmable Logic Controller (PLC). A LabView-based user interface program was developed to control the baking process and for data acquisition (temperature, vacuum and residual gas analysis).

For RF processing, RF power meters, fast-response vacuum controllers and a feedback RF control loop were used. Additionally, flow and temperature of the cooling water in the inner extensions were monitored and interlocked with the PLC.

3.4 RF System

An RF system consisting of a 805 MHz, 2.5 MW pulsed klystron connected via WR975 waveguide to a water-cooled high-power load was used to transfer the RF power through the FPCs as shown in Figure 5. Three sets of directional couplers (two between the klystron and the test cart and one between the test cart and the terminating load) were used to independently measure the transmitted RF power levels. Additionally, as a calibration measure, the transmitted power was measured calorimetrically at the terminating load [7].

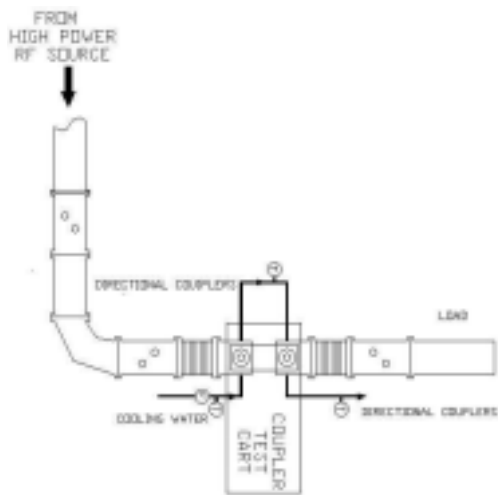

Figure 5: RF layout used in testing SNS couplers

4 ASSEMBLY AND TESTING PROCEDURES

4.1 Incoming Inspection

Before assembly, all components underwent incoming inspections, including dimension checks, visual examinations, and vacuum leak checks. In addition, the copper-plating adherence to the stainless steel outer conductor was checked with high-pressure water rinsing.

4.2 Cleaning

The outer conductors and all the stainless steel components (bellows, vacuum manifolds, connecting

waveguide) were cleaned by immersion in an ultrasonic bath, followed by a DI-water rinse and drying with dust-free nitrogen gas. In addition to this, prior to drying, the window assemblies were also cleaned with DI water jets to reduce concentration of dust particles and contaminants trapped in the windows' RF chokes.

4.3 Mechanical Assembly, Vacuum Tests and Baking

The window assemblies were inserted into the outer conductors and connecting waveguide in a class-100 clean room. The instrumentation ports on the window assembly were equipped with a vacuum gauge, an electron pick-up antenna and two sapphire optical viewports for an infrared detector and an arc detector.

The assembled connecting waveguide with the two couplers was transferred to the test cart and connected to the vacuum system. The entire system was then vacuum leak checked.

The FPC couplers and the waveguide were baked out at 200°C for 24 hours to remove the adsorbed water [8].

The couplers' extensions were attached after baking. Figure 6 shows a preliminary RF check of the assembled FPCs.



Figure 6: FPCs mounted on connecting waveguide

4.4 System Check-Out

Prior to testing at the Los Alamos National Laboratory, the first two SNS prototype FPCs were assembled at TJNAF on the test cart, baked, and then connected to an 805-MHz, 20-kW system.

As a system checkout test, 1 kW of CW power was transferred through the two FPCs. This initial commissioning verified all the aspects of the testing, from assembly to power control, and was also a test of all the safety and operational procedures necessary for a successful testing of the couplers. The test stand was then transferred to LANL for the full power testing.

5 TEST RESULTS

5.2 Results

RF conditioning at high power was performed at LANL. Starting with a pulse duration of 1 ms at 1 pps repetition rate, over 100 kW peak power was reached without any vacuum activity. A vacuum outburst occurred at about 125 kW. After vacuum recovery, the normal conditioning process (with vacuum and electron activity) was restarted from 35 kW. In about 32 hours of RF conditioning with different pulse durations and repetition rates (from 100 μ s to 1 ms and at 1, 10 and 20 pps), 500 kW peak power was reached (Figure 7). (Due to power supply limitations, the pulse rate was only 20 pps instead of the 60 pps used during operation; therefore, the FPCs only reached 33% of the average operational power.)

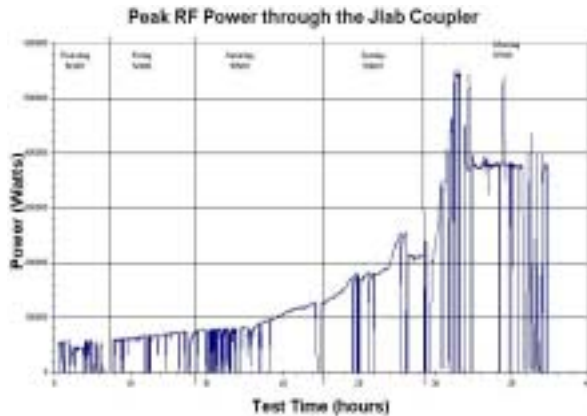

Figure 7: RF conditioning and power tests as recorded on an independent power meter at LANL.

After RF conditioning, no evidence of multipacting was observed at power up to 550 kW. Also, no appreciable temperature increase on the FPC components was observed during RF processing.

5.3 Reconditioning

The test cart and the SNS FPCs were kept under vacuum for a period of two weeks and then exposed again to RF (pulse duration 1 ms and repetition rate 20 pps). Less than two hours RF reconditioning was necessary before reaching 300 kW.

After reconditioning, no more arcing or vacuum events were observed and the RF power could be cycled and maintained constant at 300 kW, then cycled again and increased to over 550 kW. A more detailed description of these testing results can be found in [9].

5.4 Recent Test Results

After a period of several months, processing was resumed at LANL. The FPCs had been exposed to air, recleaned and reassembled. Conditioning began at 1 kW and proceeded, over a period of days, to a maximum power of 720 kW (at 30 pps, an average power of 22 kW).

Some outgassing was seen, with the primary constituents being H₂ and water vapor. There was only minor heating of the window and the inner conductor tip (less than ten degrees Celsius).

6 CONCLUSIONS

The prototype FPC for the SNS superconducting cavities has been designed based on a scaled design for the KEK-B coupler. Some modifications were made to adapt the FPC to the design requirements of the SNS cryomodule. The FPCs have been processed on a stand which is designed to accommodate in-situ baking and RF conditioning under vacuum. Peak power levels in excess of 700 kW were achieved without evidence of any significant design problems.

Four couplers are currently being processed at Los Alamos in a similar fashion. The work will continue to extend the tests on additional FPCs to a full 1 MW standing wave power at 60 pps.

7 ACKNOWLEDGEMENTS

The authors wish to thank the FPC design and testing teams and the LANL personnel for their invaluable help.

8 REFERENCES

- [1] T. E. Mason, "The Spallation Neutron Source: A Powerful Tool for Materials Research," PAC2001, Chicago, IL, June 2001.
- [2] G. Ciovati et al., "Superconducting Prototype Cavities for the Spallation Neutron Source (SNS) Project," PAC2001, Chicago, IL, June 2001.
- [3] S. Mitsunobu et al., "High Power Input Coupler for KEKB SC Cavity," 9th Workshop on RF Superconductivity, Santa Fe, NM, November 1999.
- [4] Y. Kang et al., "Electromagnetic Simulations and Properties of the Fundamental Power Couplers for the SNS Superconducting Cavities," PAC2001, Chicago, IL, June 2001.
- [5] W. R. Fowkes et al., "1.2-MW Klystron for Asymmetric Storage Ring B-Factory," PAC95, Dallas, TX, May 1995.
- [6] I. E. Campisi et al., "The Fundamental Power Coupler Prototype for the Spallation Neutron Source (SNS) Superconducting Cavities," PAC 2001, Chicago, IL, June 2001.
- [7] K.A. Cummings et al., "Results and Lessons Learned from Conditioning 1 MW CW 350 MHz Coaxial Vacuum Windows," Linac98, Chicago, IL, August 1998.
- [8] M. Stirbet et al., "Processing Test Stand for the Fundamental Power Couplers of the Spallation Neutron Source (SNS) Superconducting Cavities," PAC2001, Chicago, IL, June 2001.
- [9] M. Stirbet et al., "Testing Procedures and Results of the Prototype Fundamental Power Coupler for the Spallation Neutron Source," PAC2001, Chicago, IL, June 2001.