

GA-A22906

CONF-980922--

**3 MW, 110 GHz ECH SYSTEM FOR THE
DIII-D TOKAMAK**

RECEIVED

AUG 10 1998

OSTI

by

**R.W. CALLIS, J. LOHR, D. PONCE, T.E. HARRIS, R.C. O'NEILL,
D.B. REMSEN, R. PRATER, and T.C. LUCE**

DISTRIBUTION OF THIS DOCUMENT IS UNLIMITED *ph*

MASTER

JULY 1998

 **GENERAL ATOMICS**

DISCLAIMER

**Portions of this document may be illegible
electronic image products. Images are
produced from the best available original
document.**

GA-A22906

3 MW, 110 GHz ECH SYSTEM FOR THE DIII-D TOKAMAK

by

**R.W. CALLIS, J. LOHR, D. PONCE, T.E. HARRIS, R.C. O'NEILL,
D.B. REMSEN, R. PRATER, and T.C. LUCE**

This is a preprint of a paper to be presented at the 20th Symposium on Fusion Technology, September 7-11, 1998, Marseille, France, and to be published in the *Proceedings*.

**Work supported by
the U.S. Department of Energy
under Contract DE-AC03-89ER51114**

**GA PROJECT 3466
JULY 1998**



3 MW, 110 GHz ECH System for the DIII-D Tokamak

R.W. Callis, J. Lohr, D. Ponce, T.E. Harris, R.C. O'Neill, D.B. Remsen, R. Prater, T.C. Luce

General Atomics, P.O. Box 85608, San Diego, California 92186-5608

1. INTRODUCTION

To support the Advanced Tokamak (AT) operating regimes in the DIII-D tokamak, methods need to be developed to control the current and pressure profiles across the plasma discharge. In particular, AT plasmas require substantial off-axis current in contrast to normal tokamak discharges where the current peaks on-axis. An effort is under way to use Electron Cyclotron Current Drive (ECCD) as a method of sustaining the off-axis current in AT plasmas. The first step in this campaign is the installation of three megawatts of electron cyclotron heating power. This involves the installation of three rf systems operating at 110 GHz, the second harmonic resonance frequency on DIII-D, with each system generating nominally 1 MW. The three systems will use one GYCOM [1] (Russian) gyrotron and two CPI [2,3] (formerly Varian) gyrotrons, all with windowless evacuated corrugated low loss transmission lines.

2. RF SYSTEM OVERVIEW

Two gyrotrons have been installed and operated on the DIII-D tokamak. One, a GYCOM gyrotron [1] has been in operation since 1996 and the second a Communications and Power Industries (CPI) gyrotron [2] model VGT-8011A has been in service since May 1997. Both gyrotrons are nominally 1 MW at a central frequency of 110 GHz. Although each gyrotron is designed for long pulse capability (>10 s), their present pulse capability is limited to 2 s and 0.8 s respectively, owing to the output windows currently installed upon the tubes. The GYCOM gyrotron uses a BN edge cooled window, and CPI uses a double disk sapphire window design with an inert Chloro-fluorocarbon (FC-75) coolant flowing between the two disks. A second CPI gyrotron with basically the same internal configuration has been built with a CVD diamond window[3]. This gyrotron offers the first practical design of 1 MW cw operation. The gyrotron performance parameters are shown in Table I.

Table I
GYROTRON PERFORMANCE PARAMETERS

	GYGOM	CPI #1	CPI #2
Frequency, GHz	109.8 – 110.15	110	110
Output Window Design	Single Disk	Double Disk	Single Disk
Material	BN	Sapphire	CVD Diamond
Cooling method	Edge Cooled	Face Cooled	Edge Cooled
RF power (kW) and Pulse Duration (s)	(960)/2.0	(350)/10 (530)/2, (1000)/.8	(1000)/10 effectively cw
Efficiency, %	38.0	32.0	32
Beam Voltage, kV	72.0	80.0	80
Beam Current, A	33.8	35	35

The transmission line is 31.75 mm diameter aluminum circularly corrugated waveguide carrying the HE_{11} mode. The waveguide diameter represents a compromise between power handling capability and the desirability that the transmission line be insensitive to misalignment, thermal growth, and motion. For the first two gyrotrons the rf beam exiting the side of the gyrotron is a modified gaussian beam with a flattened profile to minimize the peak temperature and thus the stresses in the window. Since the window and rf beam are made as large as practical, ≈ 100 mm, to reduce the thermal load on the window, direct coupling from the gyrotron into the waveguide is impractical and an interface device is required. Using two mirrors, the rf beam exiting the gyrotron is phase corrected to restore it to a free-space Gaussian and is then focused to couple into the 31.75 mm waveguide diameter. These mirrors are housed in a Mirror Optics Unit (MOU) which also contains a water-cooled resistive load, which absorbs any stray rf power that exits the gyrotron at an angle that can not be focused into the waveguide. The output beam of the diamond window gyrotron is a free-space Gaussian, but is larger in diameter, ≈ 51 mm, than the 31.75 mm diameter of the waveguide, so a MOU will also be needed to focus the beam into the waveguide.

An entire single transmission line system, shown in Fig. 1, consists of six mitre bends and is ≈ 40 m long with an estimated 2% loss in the waveguide and 0.6% loss per mitre bend. The mitre bend losses are from mode conversion 0.5% and ohmic losses 0.1%. The waveguide is evacuated to a pressure of $\approx 1 \times 10^{-5}$ Torr by a turbomolecular pump at the MOU and a similar pump on a special section of waveguide near the tokamak, where the waveguide has been slotted to allow pumping between the corrugations. This waveguide pumping section is placed as close to the DIII-D vacuum vessel as practical so that any impurities evolving from the waveguide upstream of the tokamak can be pumped out before they reach the plasma and possibly contaminate it. For the FC-75 cooled CPI gyrotron a fast shutter located just upstream of the pumping section has been installed. This shutter can close faster than the pressure wave can travel down the waveguide and, in conjunction with the pumping section, maintains the vacuum pressure at the tokamak entrance waveguide. To aid in gyrotron optimization a dummy load is connected to the system via a waveguide switch located near the gyrotron. Polarization control is achieved by a set of grooved motorized polarizing mirrors mounted in two of the mitre bends. By appropriate rotation of these two mirrors, any elliptical polarization desired can be obtained.

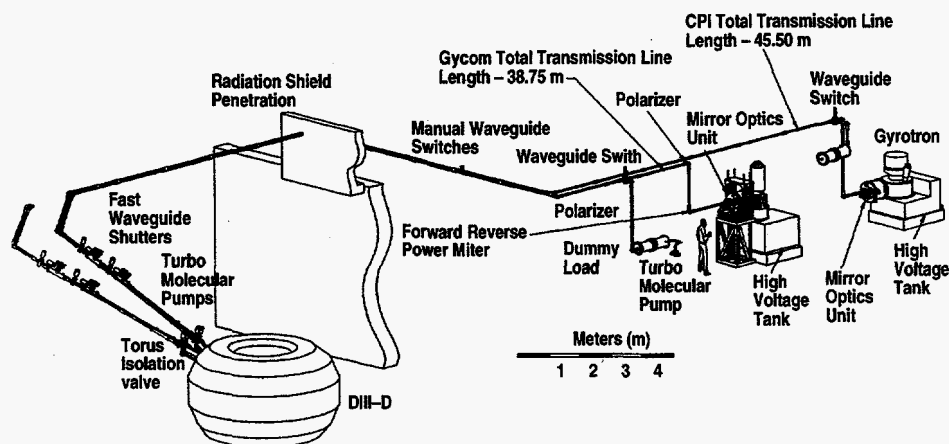

Fig. 1. ECH System layout showing the routing of the transmission line and the location of the major transmission line components.

There are two sets of dual launchers attached to DIII-D. Each launcher is composed of two mirrors; a focusing mirror and a flat tilting mirror. In the first set the flat mirrors are permanently angled at 19° off normal to provide the appropriate current drive injection angle. The flat tilting mirror rotates vertically so the injected beam can be steered poloidally from slightly below the midplane, to the outermost top edge of the plasma. On the second set of launchers the tilting mirrors are aimed normal to the plasma. The two gyrotrons can be interchanged between these two launcher sets by the simple task of breaking the connection at the second-to-last mitre bend and adding or removing a 2 m length of waveguide.

3. INITIAL OPERATION INTO DIII-D

The initial ECH system checkout and operation of the first two gyrotron systems has been described in Ref. 4, and since that time ECH Experiments have been performed on the DIII-D tokamak using up to 1.5 MW of 110 GHz power from the two gyrotron systems. For these experiments the GYCOM gyrotron was operated for 2 s pulses at 0.8 MW and the CPI #1 gyrotron for 1 s at 0.7 MW.

3.1. Plasma Heating Characteristics

By modulating the ECH power and detecting the modulation with the various chords of the electron cyclotron emission (ECE) diagnostic, the power deposition profile of the rf beam can be measured directly. Figure 2(a) shows the ray path for a radial launch of the rf beam with a flat tilting mirror angle of 62° . The measurements of the 32 channel ECE diagnostic is shown in Fig. 2(b). Measurements were made with the waveguide polarizers set to launch O-mode only, X-mode only and combined O+X-mode. Note the X-mode polarization has a peaked power absorption at $\rho = 0.45$, where the launched beam crosses the 2ω resonance layer. For O-mode the low electron temperature at the first interception of the resonance zone produces weak absorption, and it is only during the second pass, at $\rho = 0.15$, after the beam bounces off the inner wall of the tokamak is there significant heating. The combine O+X-mode launch shows a dual absorption but with a lower peak power density owing to the power being spread over a larger plasma volume.

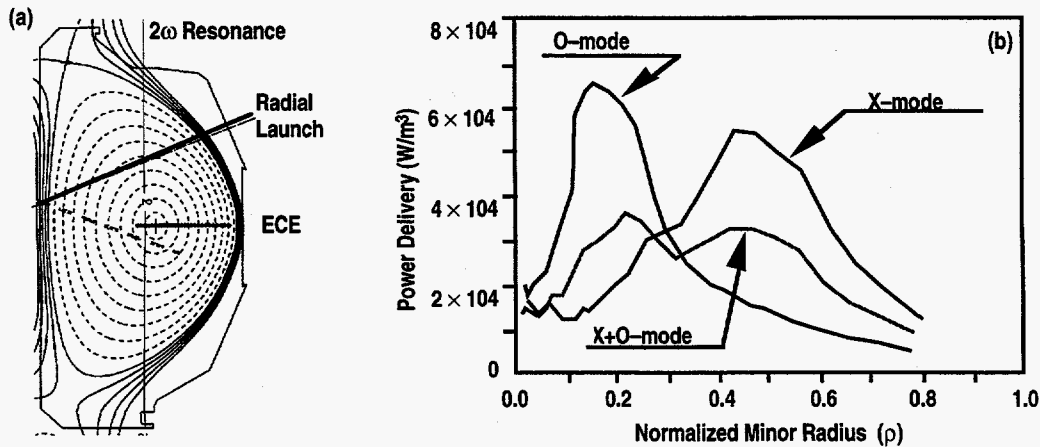

Figure 2. (a) ECH ray path through the plasma, for a launching mirror angle of 62° . (b) Amplitude of the absorbed power density as a function of the plasma minor radius, from ECE measurements, for O-mode, X-mode and O+X-mode polarization. The modulation frequency is 100 Hz.

3.2. Electron Cyclotron Current Drive

Both on-axis and off-axis ECCD experiments have been performed using the two gyrotron systems. In these experiments a low density plasma, $\approx 1 \times 10^{19} \text{m}^{-3}$, is preheated with neutral beams to improve rf absorption and to suppress sawteeth during the current drive phase. Using the method of time sequence equilibrium reconstruction, the current density and local electric field E (from the time derivative of the flux) the EC-driven current density can be found [5]. EC-driven currents up to 170 kA for on-axis heating and 50 kA for off-axis heating have been determined using this method. Figure 3 shows calculations for a pair of discharges with and without on-axis ECH. Note the highly localized central current density when ECH is applied in Fig. 2(a), this demonstrates the effectiveness that ECH can have on modifying the current profile. The 170 kA of ECCD is in good agreement with code predictions and represents a figure of merit of $\gamma = 0.35 \times 10^{19} \text{A/W m}^2$.

4. CONCLUSION

The first two of three 1 MW ECH systems is operating routinely at DIII-D with injected power at 110 GHz of approximately 1.5 MW with good power accountability. Transport experiments using modulated ECH have been performed confirming the power deposition location. On-axis and off-axis current drive experiments have been successfully performed with on-axis ECCD currents of 170 kA being observed.

ACKNOWLEDGMENT

Work supported by U.S. Department of Energy under Contract No. DE-AC03-89ER51114.

REFERENCES

- [1] Agapova, M.V., *et al.*, Proc. 20th Int. Conf. on Infrared and Millimeter Waves, Ed. R. Temkin, Boca Beach, Florida, 205, 1995.
- [2] Felch, K., *et al.*, Proc. 20th Int. Conf. on Infrared and Millimeter Waves, Ed. R. Temkin, Boca Beach, Florida, 191, 1995.
- [3] Felch, K., *et al.*, Proc 22st Int. Conf on Infrared and Millimeter Waves, Colchester, England, 1998, to be published.
- [4] Callis, R.W., *et al.*, to be published in the Proc. 17th Symposium on Fusion Engineering, San Diego, CA., 1997.
- [5] Prater, R., *et al.*, Proc. of the second Europhysical Topical Conference on RF Heating and Current Drive of Fusion Devices, January 1998, Brussels, Belgium.

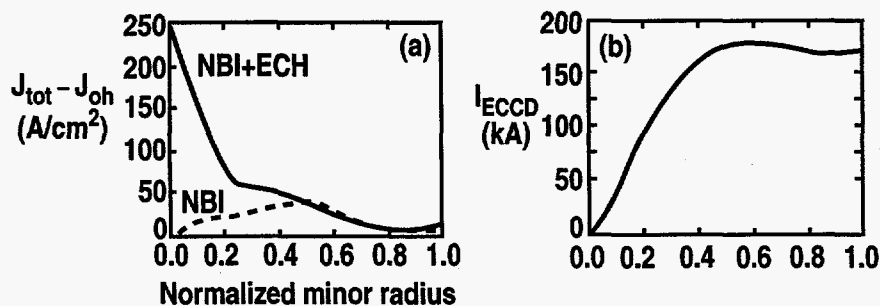

Figure 3 Profiles for two discharges, one with 0.82 MW of ECH (solid line) and one without ECH (dashed line). (a) noninductive current density, and (b) integrated current. The NB power is 2.8 MW, the density is $1 \times 10^{19} \text{m}^{-3}$, and the plasma current is 1.0 MA.