

C13.44:97 (a Errata)

NBS MONOGRAPH 97

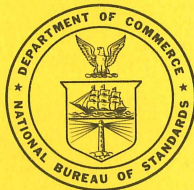

**MICROWAVE ATTENUATION
MEASUREMENTS AND STANDARDS**



UNIVERSITY OF
ARIZONA LIBRARY
Documents Collection
APR 12 1967

**U.S. DEPARTMENT OF COMMERCE
NATIONAL BUREAU OF STANDARDS**

THE NATIONAL BUREAU OF STANDARDS

The National Bureau of Standards is a principal focal point in the Federal Government for assuring maximum application of the physical and engineering sciences to the advancement of technology in industry and commerce. Its responsibilities include development and maintenance of the national standards of measurement, and the provisions of means for making measurements consistent with those standards; determination of physical constants and properties of materials; development of methods for testing materials, mechanisms, and structures, and making such tests as may be necessary, particularly for government agencies; cooperation in the establishment of standard practices for incorporation in codes and specifications; advisory service to government agencies on scientific and technical problems; invention and development of devices to serve special needs of the Government; assistance to industry, business, and consumers in the development and acceptance of commercial standards and simplified trade practice recommendations; administration of programs in cooperation with United States business groups and standards organizations for the development of international standards of practice; and maintenance of a clearinghouse for the collection and dissemination of scientific, technical, and engineering information. The scope of the Bureau's activities is suggested in the following listing of its three Institutes and their organizational units.

Institute for Basic Standards. Applied Mathematics. Electricity. Metrology. Mechanics. Heat. Atomic Physics. Physical Chemistry. Laboratory Astrophysics.* Radiation Physics. Radio Standards Laboratory.* Radio Standards Physics; Radio Standards Engineering. Office of Standard Reference Data.

Institute for Materials Research. Analytical Chemistry. Polymers. Metallurgy. Inorganic Materials. Reactor Radiations. Cryogenics.* Materials Evaluation Laboratory. Office of Standard Reference Materials.

Institute for Applied Technology. Building Research. Information Technology. Performance Test Development. Electronic Instrumentation. Textile and Apparel Technology Center. Technical Analysis. Office of Weights and Measures. Office of Engineering Standards. Office of Invention and Innovation. Office of Technical Resources. Clearinghouse for Federal Scientific and Technical Information.**

*Located at Boulder, Colorado 80302.

**Located at 5285 Port Royal Road, Springfield, Virginia 22151.

C13 44:97/msta

Errata Sheet for
NBS Monograph 97
Microwave Attenuation Standards and Measurements
by Robert W. Beatty

- p. 3 Section 2.2, paragraph 4, line 1
Change "1953" to "1959"
- p. 17 Section b, paragraph 4, line 1
Change "messurement" to "measurement"
- p. 19 Section 3.4, paragraph 7, line 2
Change "30 GHz" to "30 MHz" and "60 GHz" to
"60 MHz"
- p. 22 line 8 Change "agaisnt" to "against"
- p. 24 paragraph 6, line 1 Change "thid" to "this"
paragraph 7, line 4 Change second "of" to "or"
paragraph 7, line 8 Change "sidely" to "widely"
- pp. 26 and 27 Interchange the diagrams of figures 10
and 11. The figure captions will then be under
the correct diagrams.
- p. 29 paragraph 2, line 2
Change "appaerently" to "apparently"
- p. 33 Section 5.5, line 2 Change first "in" to "an"
- p. 42 Change reference 1 to read:
IRE standards on antennas and waveguides:
Waveguide and waveguide component measurements,
1959, Proc. IRE 47, No. 4, 568-582, April, 1959,
Standard 59 IRE 2.51, 1959.

UNIVERSITY OF
ARIZONA LIBRARY
Documents Collection
AUG 15 1967

June 1967

Mg 8/31/67

UNITED STATES DEPARTMENT OF COMMERCE
Alexander B. Trowbridge, *Acting Secretary*
NATIONAL BUREAU OF STANDARDS • A. V. Astin, *Director*

Microwave Attenuation Measurements and Standards

Robert W. Beatty
Institute for Basic Standards
National Bureau of Standards
Boulder Laboratories
Boulder, Colorado 80302



National Bureau of Standards Monograph 97

Issued April 3, 1967

For sale by the Superintendent of Documents, U.S. Government Printing Office
Washington, D.C. 20402 - Price 25 cents

Library of Congress Catalog Card No. 66-62097

Preface

This publication is an introductory, inclusive review of microwave attenuation measurement methods and standards. It presents some relatively new material on basic concepts including a more rigorous analysis of mismatch and connector errors.

Particular attention is given to analysis and discussion of errors in methods that permit the highest precision. The means by which confidence is developed in attenuation standards are described, and criteria are given which attenuators should satisfy if they are to be worthy of precise calibration. Methods of measurement are classified, including those not requiring any attenuation standard, and each method is evaluated on the basis of convenience and accuracy.

A list of selected references, covering most of the significant developments in the field, is included.

Contents

	Page
Preface.....	III
1. Introduction.....	1
2. Definitions of attenuation, error analyses.....	2
2.1. Selection of a model for an attenuator.....	2
2.2. Insertion loss.....	3
2.3. Substitution loss.....	4
2.4. Analysis of substitution loss.....	6
2.5. Expression for insertion loss.....	8
2.6. Expression for attenuation.....	8
2.7. Analysis of attenuator calibration.....	9
2.8. Analysis of mismatch and connector errors.....	10
2.9. Intrinsic attenuation.....	12
3. Standards of attenuation.....	14
3.1. Power ratio standards at d-c and audio frequencies.....	14
a. Power ratio standards at d-c.....	14
b. Power ratio standards at audio frequencies.....	14
3.2. Broadband attenuators.....	15
3.3. Waveguide-below-cutoff attenuators.....	15
a. General considerations.....	15
b. Dimensional tolerances and accuracy of measurement of displacement.....	17
c. Skin depth corrections.....	18
d. Loading effects.....	18
e. Mode purity.....	18
3.4. Rotary vane type attenuators.....	19
4. Types of attenuators suitable for calibration.....	20
4.1. Criteria for suitable attenuators.....	20
4.2. Coaxial attenuators.....	21
4.3. Attenuators in rectangular waveguide.....	21
5. Measurement methods.....	22
5.1. Classification of methods.....	22
5.2. D-c substitution.....	23
5.3. Audio substitution.....	25
5.4. IF substitution.....	27
a. General considerations.....	27
b. Discussion of errors.....	28
Introduction.....	28
Mismatch errors.....	28
Converter errors.....	29
Instability of signal source.....	29
RF leakage.....	30
IF leakage.....	31
Errors in standard attenuator.....	31
Noise.....	31
Errors from connectors or waveguide joints and from waveguide or cable.....	32
Errors associated with the device under test.....	32
Overall error.....	33
5.5. Modulated subcarrier.....	33
5.6. Direct substitution.....	34
5.7. Short-circuited attenuator.....	37
5.8. Methods not requiring attenuation standards.....	38
5.9. Measurement of small attenuation.....	40
6. Conclusions.....	41
7. References.....	42

Microwave Attenuation Standards and Measurements

R. W. Beatty

A comprehensive and commentarial review of microwave attenuation measurement methods and standards is presented. In addition, a relatively new and more precise way of representing and analyzing an attenuation measurement is presented. This in turn permits more rigorous definitions and error analyses than were previously possible. Expressions for both mismatch and connector errors are presented.

The referral of microwave attenuation measurements to standards operating at lower frequencies is discussed with particular attention to the errors in the referral processes as well as the errors in the standards themselves. Standards operating at d-c, audio frequencies, and higher frequencies are included in this discussion which covers waveguide-below-cutoff attenuators and rotary vane attenuators.

Desirable characteristics are listed for attenuators which are suitable for calibration, and examples of these are given.

Measurement methods are classified and described, giving greatest emphasis to the intermediate-frequency substitution method using a waveguide-below-cutoff standard attenuator, and to d-c substitution techniques. Methods for measurement of small attenuations as well as methods not requiring reference to any standard attenuators are covered.

Comments are made on the accuracy and convenience of various methods, and references are given which cover most of the basic and important research in this field.

Key words: Microwave, attenuation, measurements, standards, tutorial.

1. Introduction

The measurement of microwave attenuation is a rather complex subject about which much has been written. There are subtle concepts involved and unfortunately, failure to handle them carefully has resulted in occasional disagreement and confusion. Thus it is important that we agree, at least in these remarks, on certain definitions and terms which will be used.

A model to represent an attenuator will be chosen from which quantitative definitions will be drawn. The analysis of mismatch errors and the effects of connectors on the measurement of attenuation will be carefully considered. The analysis will initially be as general as possible, and special cases will then be considered.

Standards of attenuation will be discussed, as well as methods of measurement which do not require reference to a standard attenuator. The types of attenuators which are considered suitable for calibration will be briefly mentioned, and various measurement methods will be described.

The discussion of measurement methods will pay special attention to sources of error and their reduction through the employment of good experimental practices.

In conclusion, an evaluation of the present state of the art as well as some predictions of future developments will be attempted.

2. Definitions of Attenuation, Error Analyses

2.1. Selection of a Model for an Attenuator

Before defining attenuation for our purposes, it is convenient to choose a model which corresponds as closely as possible to actual situations to be encountered. We can then base quantitative definitions and the analysis of errors on this model.

It has been customary to use as a model for an attenuator a two-port, as shown in figure 1(b), to which one has access by means of ideal waveguide leads (or uniform, lossless transmission lines). Although this has proven satisfactory for most purposes and will no doubt continue to be used, it is not satisfactory when extremely precise results are desired. A slightly more complicated model as shown in figure 1(c) will be initially considered. This model is a more faithful representation of the actual situations encountered and permits more rigorous definitions and analyses. This approach is used because it will give a truer picture of what actually occurs in an attenuation measurement.

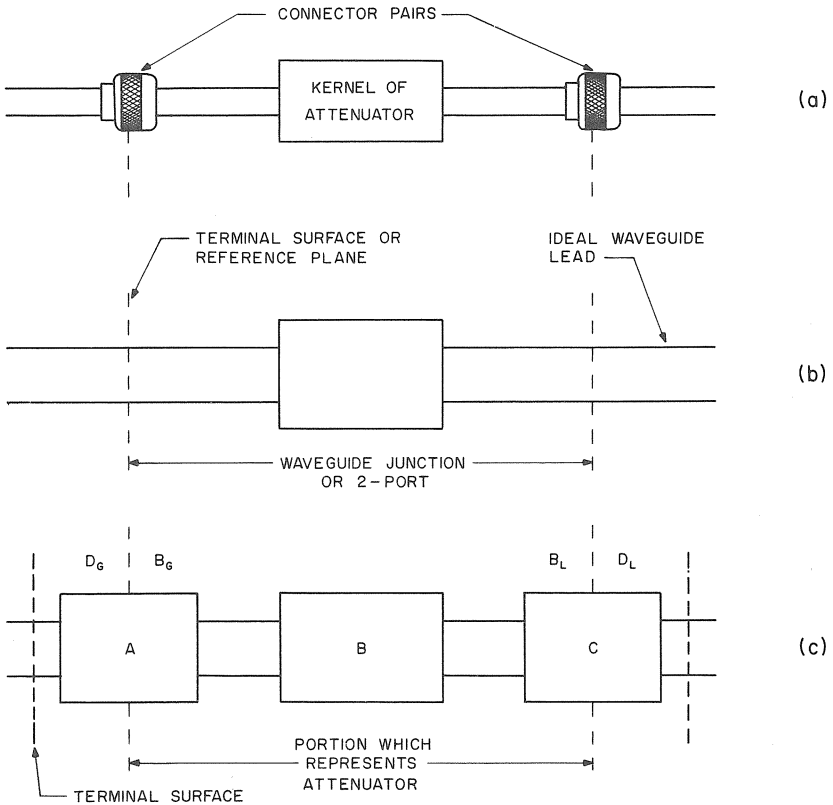

FIGURE 1. Two models to represent an attenuator.

(a) an attenuator, (b) a two-port representation, (c) use of three cascaded two-ports to represent an attenuator connected in a system. Connector pairs are represented by two-ports A and C. The individual connectors are not separately represented by two-ports but are designated by D_G , B_G , B_L , and D_L .

The simpler model which is normally used will be regarded as a special case of the more rigorous model, and the assumptions required to derive the usual equations will then be clearly stated.

The case of a single fixed attenuator is considered first in detail. Consideration of variable attenuators follows in outline form.

2.2. Insertion Loss

When an attenuator is used between a generator and a load, one is interested in its effect on the power P_L absorbed by the load. P_L is also called the power delivered to the load, the net power to the load, the power received at the load, and the power dissipated in the load—all of these terms being equivalent.

The procedure in an attenuation measurement is simply to open up the waveguide system at some point, insert the attenuator, and note the relative powers absorbed by the load. In the case of a variable attenuator, it is inserted and remains in the circuit while it is adjusted from an initial setting to a final setting. Again, the relative powers absorbed by the load are noted.

Because of the insertion process, it is generally regarded that one actually measures insertion loss or changes of insertion loss by the above procedures. This is certainly true, if the definition of insertion loss [1]¹ is the ratio, expressed in decibels, of the power received at the load before insertion of the attenuator, to the power received at the load after insertion. Note that nothing is said about the initial condition of the system which will depend upon the characteristics of the connector pair at the insertion point. This is one defect of this concept when one desires precise terminology.

Note also that the 1953 IRE standard [1] gives two definitions for insertion loss; a general one in which the system mismatch is not specified, and a particular one in which the system is non-reflecting. One cannot have it both ways at once, since the insertion loss of an attenuator will amount to a different number of decibels in each case. A way out of this dilemma is to call the insertion loss in a non-reflecting system the "attenuation." Actually this conforms to longstanding usage by early workers at the M.I.T. Radiation Laboratory and elsewhere. These definitions still are defective in that they say nothing about the connector pair at the insertion point in the system. *

Although this definition applies to most procedures used in attenuation measurements, the term "insertion loss" has been associated with various modifications [2] of this basic concept, and the exact meaning has become unclear. In addition, the model used in the analysis of insertion loss has been a simple one, and not truly representative of the actual situation. One can apply a more rigorous model which accounts for the connector pair at the insertion point and make a different analysis, obtaining a different equation for insertion loss. However, this would result in a situation in which two different equations were obtained for the same loss concept.

The problem would be solved if agreement could be obtained on a definition of attenuation in which the connector pair at the insertion point and the system mismatch conditions were clearly specified [3].

¹ Figures in brackets indicate the literature references at the end of this Monograph.

An alternate way out of this difficulty is to introduce a slightly more general loss concept [2] called "substitution loss," of which "insertion loss" is a special case. The analysis of this more general concept makes use of the more rigorous model and results in equations which can then be specialized to yield the conventional ones for insertion loss, attenuation and other quantities. In using the concept of substitution loss, the initial condition of the system before insertion of the attenuator must be clearly specified.

2.3. Substitution Loss

When measuring the loss produced by a fixed attenuator, one must first break the circuit at the point where the attenuator is to be inserted. This may be done by separating a connector pair, for example. Or if the attenuator is to be inserted at a place where two different types of waveguides are connected together by an adapter, this adapter might need to be removed. In any case, the attenuator is substituted for the joining device initially in the circuit at the insertion point.

This procedure may be represented as in figure 2, where an initial and a final two-port represent the joining device and the attenuator, respectively. The quantity of interest is P_L , the power absorbed by the load, and the effect on P_L of the substitution process is measured and is called the substitution loss, L_S . It is the ratio expressed in decibels of iP_L , the power initially absorbed by the load to fP_L , the power finally absorbed by the load after the substitution process has been completed. It is written

$$L_S = 10 \log_{10} \left(\frac{{}^iP_L}{{}^fP_L} \right). \quad (1)$$

It is usually assumed that the initial and final conditions of the signal source and the load are the same. However, special precautions may be required to enforce this state of affairs in an actual measurement system. The possibility that the initial and final generator and load conditions might not be the same is recognized by distinguishing between ${}^i b_G$ and ${}^f b_G$, between ${}^i \Gamma_G$ and ${}^f \Gamma_G$, and between ${}^i \Gamma_L$ and ${}^f \Gamma_L$ in figure 2. The generator wave amplitudes delivered to non-reflecting loads are designated by ${}^i b_G$ and ${}^f b_G$.

The substitution process represented by figure 2 is quite general and can apply to the procedure used in measuring variable attenuators as well as fixed attenuators. When the attenuator is variable in steps, as is the case with a drum-type attenuator, the substitution of another step on the drum for the initial or "zero decibel" step corresponds very closely to the substitution process shown in figure 2. When the attenuator is continuously variable, a change of the attenuator from its initial or "zero" setting to another setting may also be represented by the substitution process, although the attenuator is not physically removed from the circuit.

The effect of connectors or adapters on the measurement of attenuation can be taken into account by application of the model of figure 1(c) to the initial and final waveguide junctions shown in figure 2. The breakdown of these waveguide junctions into their component two-ports is shown in figure 3 for the measurement of fixed attenuators, figure 4 for the measurement of attenuators variable in steps such as drum-type

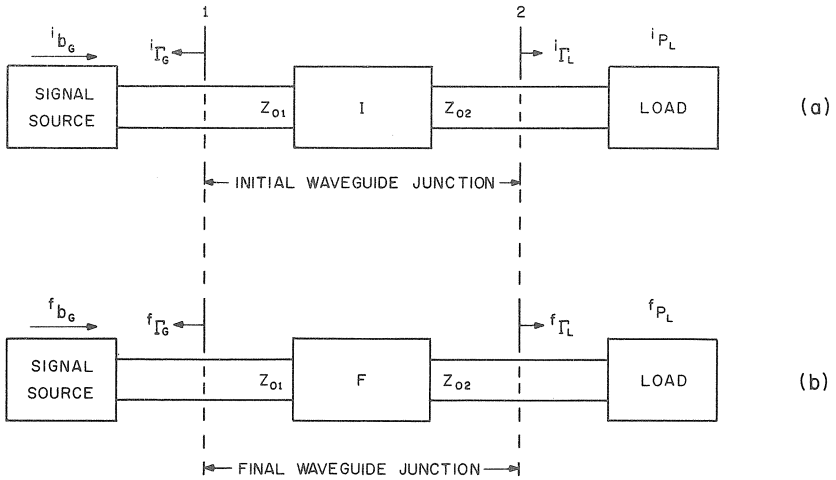

FIGURE 2. The general representation of the situation that occurs when an attenuator is inserted into a waveguide system.

(a) In general, an adapter or a connector pair (represented by the initial waveguide junction) is initially in the waveguide circuit. An adapter is required to join two different kinds of waveguides which may have the characteristic impedances Z_{01} and Z_{02} as shown. When the two waveguides are alike, then $Z_{01} = Z_{02}$, and a connector pair joins them. (b) The attenuator and its associated connector pairs (represented by the final waveguide junction) is substituted for the initial adapter or connector pair.

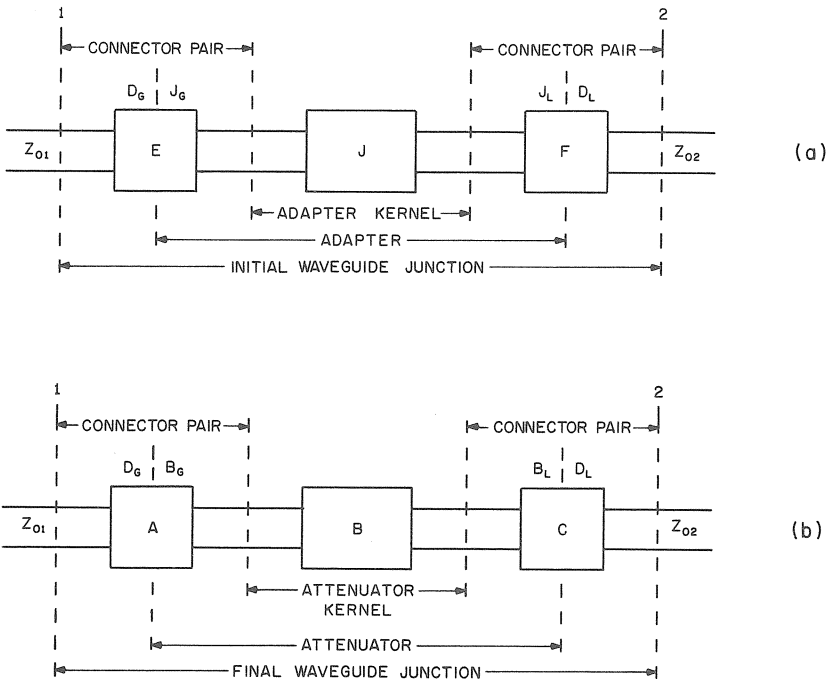

FIGURE 3. Representation of a fixed attenuator inserted into a waveguide system.

The breakdown of initial and final waveguide junctions into their component two-port representations is shown. (a) The adapter consists of a central portion or kernel to which is attached portions of connector pairs, the connector on one end being in general of a different type than that on the other end. (b) The attenuator consists of a central portion or kernel to which is attached connectors which will mate with the connectors belonging to the waveguide system to form the connector pairs (represented by two-ports).

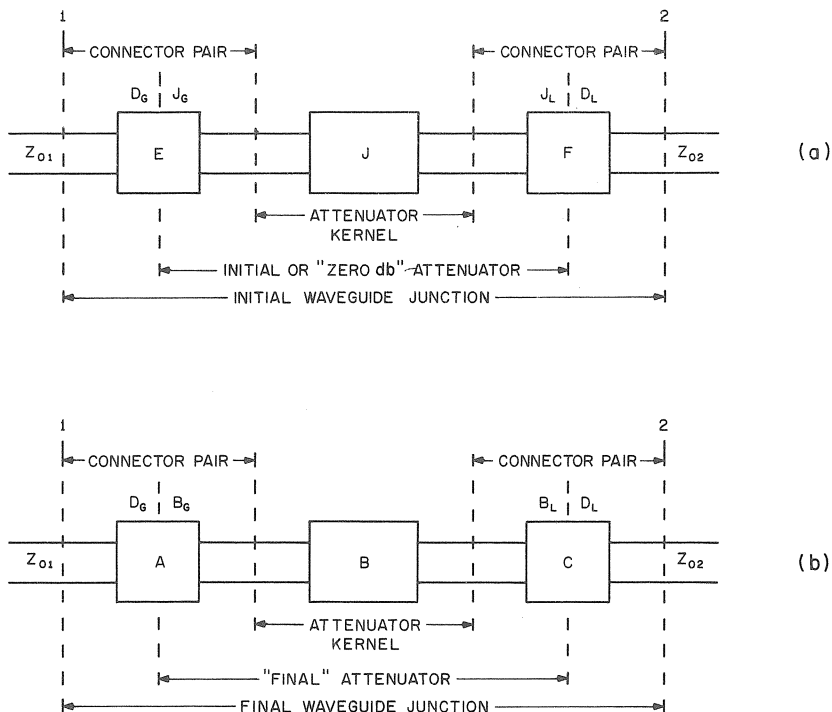

FIGURE 4. Representation of an attenuator variable in steps such as a drum-type attenuator.

(a) Initial or "zero decibel" attenuator installed in the circuit.

(b) Final attenuator installed in the circuit.

Usually the connector pairs represented by two-ports A, C, E, and F will be nearly identical but are shown individually for generality.

attenuators, and figure 5 for continuously variable attenuators. Unlike connector pairs, the individual connectors cannot be represented by two-ports because one cannot in general couple into and out of a single connector by means of lossless waveguide leads alone. Another connector is needed, and this forms a connector pair.

In the special case where mating surfaces of inner and outer conductors are coplanar, one can closely approach representation of a single connector by a two-port [4]. However, one is left with a "contact impedance" associated with the joint. By arbitrarily dividing this in half and assigning each half to one of the connectors, one probably can come close to a valid representation of a connector of this type, especially if the "contact impedance" is small. Any non-repeatability obtained in mating two given connectors can then be ascribed to variations in the "contact impedance."

2.4. Analysis of Substitution Loss

If one refers to the definition given previously for substitution loss and uses the representation of figure 2, then eq (1) is obtained. It is useful to put eq (1) into a form which explicitly involves the characteristics of the generator and load as well as those of the initial and final waveguide junctions. The scattering coefficients of the initial and final

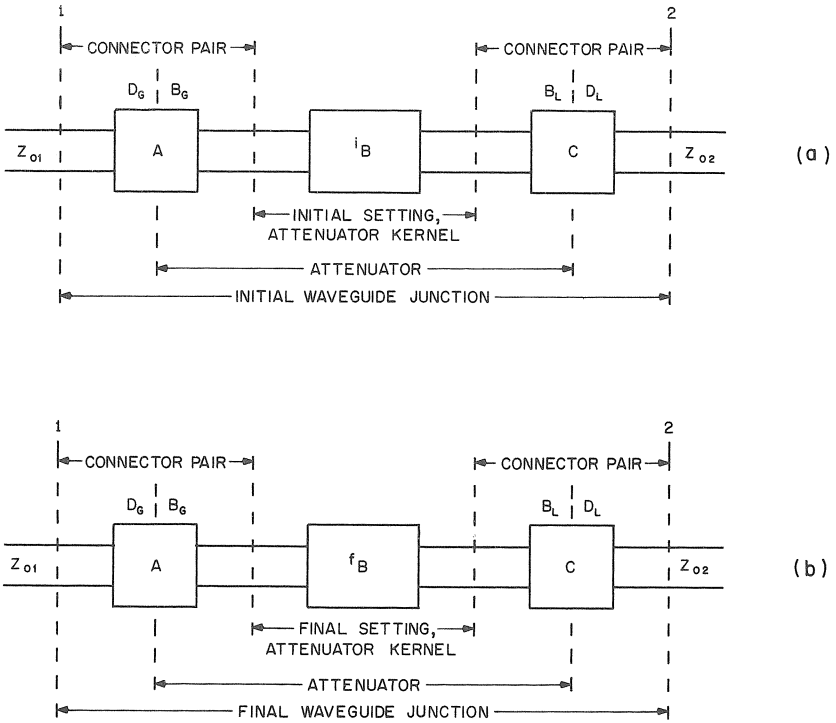

FIGURE 5. Representation of a continuously variable attenuator installed in a waveguide system.

It is assumed that the connector pairs represented by two-ports A and C do not change.

(a) An initial two-port iB represents the initial setting of the attenuator kernel.

(b) A final two-port fB represents the final setting of the attenuator kernel.

waveguide junctions are denoted by ${}^iS_{11}$, ${}^iS_{12}$, ${}^iS_{21}$, ${}^iS_{22}$, ${}^fS_{11}$, ${}^fS_{12}$, ${}^fS_{21}$, and ${}^fS_{22}$, where the front superscripts i and f refer to initial and final conditions, respectively. The substitution loss can be written [5] as follows:

$$L_S = 10 \log_{10} \left[\frac{{}^i b_G \cdot {}^i S_{21} \cdot (1 - {}^f S_{11} {}^f \Gamma_G)(1 - {}^f S_{22} {}^f \Gamma_L) - {}^f S_{12} {}^f S_{21} {}^f \Gamma_G {}^f \Gamma_L}{{}^f b_G \cdot {}^f S_{21} \cdot (1 - {}^i S_{11} {}^i \Gamma_G)(1 - {}^i S_{22} {}^i \Gamma_L) - {}^i S_{12} {}^i S_{21} {}^i \Gamma_G {}^i \Gamma_L} \right]^2 \cdot \frac{1 - |{}^i \Gamma_L|^2}{1 - |{}^f \Gamma_L|^2}. \quad (2)$$

It is of interest to consider the effect of a number of special conditions upon eq (2) because these special conditions can be closely realized in practice.

If the signal source or generator is stable and well isolated from pulling effects, then we can assume that ${}^i b_G = {}^f b_G$ and ${}^i \Gamma_G = {}^f \Gamma_G$. Alternatively one can assume that even though such changes might occur, their values at the instant of the final measurement of P_L are readjusted to equal their initial values. Assuming that the initial and final loads are the same, the equation for substitution loss is then

$$L_S = 20 \log_{10} \left| \frac{{}^iS_{21} \cdot (1 - fS_{11}\Gamma_G)(1 - fS_{22}\Gamma_L) - fS_{12}fS_{21}\Gamma_G\Gamma_L}{{}^fS_{21} \cdot (1 - {}^iS_{11}\Gamma_G)(1 - {}^iS_{22}\Gamma_L) - {}^iS_{12}{}^iS_{21}\Gamma_G\Gamma_L} \right|. \quad (3)$$

2.5. Expression for Insertion Loss

In the definition given for insertion loss, the initial condition of the system is not usually specified, but in many analyses [6], it is assumed that the system can be broken apart at the insertion point without introducing any discontinuity. This is equivalent to considering insertion loss as a special case of substitution loss, in which the initial waveguide junction is a perfect connector or adapter (one having no dissipative loss, no reflection, and no phase shift). For such an adapter, the scattering coefficients will satisfy the following relationships:

$$\left\{ \begin{array}{l} {}^iS_{11} = {}^iS_{22} = 0 \text{ (non-reflection),} \\ {}^iS_{12} = \frac{Z_{01}}{Z_{02}} {}^iS_{21} \text{ (reciprocity), and} \\ {}^iS_{12}{}^iS_{21} = 1 \text{ (no dissipative loss and no phase shift).} \end{array} \right. \quad (4)$$

Substitution of these conditions into eq (3) yields the following equation for the insertion loss:

$$L_I = 10 \log_{10} \left[\frac{Z_{02}}{Z_{01}} \cdot \left| \frac{(1 - S_{11}\Gamma_G)(1 - S_{22}\Gamma_L) - S_{12}S_{21}\Gamma_G\Gamma_L}{S_{21}(1 - \Gamma_G\Gamma_L)} \right|^2 \right]. \quad (5)$$

The above expression gives the insertion loss of the final waveguide junction which represents the attenuator. The representation by a single two-port as in figure 1(b) is tacitly assumed, since it would make little sense to assume that the connectors were perfect in the initial waveguide junction but not in the final waveguide junction. In the usual case, the waveguides are practically identical and propagating a single mode so that one conveniently sets $Z_{01} = Z_{02}$ in eq (5).

It is observed that the insertion loss cannot be considered characteristic of a device because it depends upon Γ_G and Γ_L , which are properties of the system external to the device. A quantity more nearly characteristic of a device is the attenuation.

2.6. Expression for Attenuation

Attenuation is defined as the insertion loss in a nonreflecting system. It is obtained from eq (5) by setting $\Gamma_G = \Gamma_L = 0$, as follows:

$$A = 10 \log_{10} \left[\frac{Z_{02}}{Z_{01}} \cdot \frac{1}{|S_{21}|^2} \right]. \quad (6)$$

It is characteristic of the two-port used to represent the attenuator and is characteristic of the attenuator to the degree that the two-port actually represents the attenuator. The faithfulness of such a representation depends upon the excellence of the connectors and/or adapters of the attenuator and of the system in which it is measured.

2.7. Analysis of Attenuator Calibration

In the calibration of an attenuator, it is universal practice to reduce the reflections of the system to a low level before observing the substitution loss. In the limit as Γ_G and Γ_L approach zero, the substitution loss according to eq (3) becomes

$$[L_S]_{\Gamma_G = \Gamma_L = 0} = 20 \log_{10} \left| \frac{iS_{21}}{fS_{21}} \right|. \quad (7)$$

This is seen to be the difference between the attenuations of the final and initial waveguide junctions.

Usually the initial waveguide junction represents a connector pair as shown in figure 6, formed of connectors similar to these on the attenuator under test. Although connectors are designed and constructed so as to closely approximate ideal conditions, they will have some dissipative loss and some loss due to reflection.

Thus the attenuation of the initial waveguide junction may be small, but is not zero, and the measured substitution loss does not equal the attenuation of the final waveguide junction. It should be noted that improved connectors have been developed, and if they are used, the need for the more precise analysis given here is diminished or even eliminated. For various reasons, improved connectors are not yet in general use, so that the precise analysis is needed if precise results are desired.

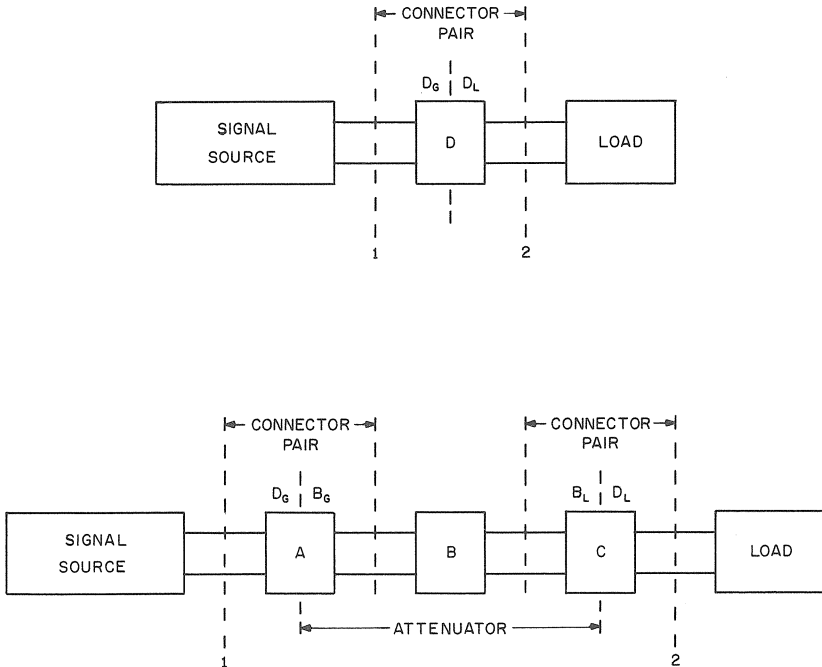

FIGURE 6. Representation of usual case of insertion of an attenuator into a waveguide system.

Actually, one may not really wish to measure the attenuation of the final waveguide junction. Instead, it may be more desirable to know the substitution loss in a nonreflecting system having a standard connector at the insertion point. This is a more realistic quantity to measure and is more characteristic of the attenuator. It is called the standard attenuation.

An expression for the standard attenuation sA is obtained from eq (7), replacing ${}^fS_{21}$ by its equivalent expression which involves the scattering coefficients of the cascaded two-ports A , B , and C , and replacing ${}^iS_{21}$ by d_{21} , the corresponding scattering coefficient of D . (It is understood that the connector pair represented by D is made strictly according to standard specifications.)

$${}^sA = 20 \log_{10} \left| \frac{d_{21}}{a_{21}b_{21}c_{21}} [(1 - a_{22}b_{11})(1 - b_{22}c_{11}) - a_{22}b_{12}b_{21}c_{11}] \right|. \quad (8)$$

In the special case when the connector pairs are all identical and non-reflecting (but have some dissipative loss), the standard attenuation becomes

$$[{}^sA]_{\Gamma_G = \Gamma_L = b_{11} = c_{11} = 0} = A_A + A_B. \quad (9)$$

$$A \equiv C \equiv D$$

This is the attenuation of the kernel B plus that of one connector pair A . Since one portion B_G of connector pair A belongs to the attenuator and the other portion is identical to connector B_L , eq (9) is a quantity that is characteristic of the attenuator itself. It follows that to the first order, the standard attenuation given by eq (8) is also characteristic of the attenuator itself.

Thus the quantity actually measured in an attenuator calibration is most closely represented by the standard attenuation. This is the substitution loss in a nonreflecting system when the initial waveguide junction is a standard connector pair. It is a quantity characteristic of the attenuator.

The analysis of the calibration of variable attenuators follows along the same lines and has been described in detail in the literature [7].

2.8. Analysis of Mismatch and Connector Errors

The errors in the measurement of standard attenuation due to mismatch and to connector deficiencies have been analyzed [7]. The basis for the analysis is shown in figure 7. The attenuator is first installed in a nonreflecting system joined by a standard connector pair, and then in a system having reflections and joined by a nonstandard connector pair. The substitution loss in the first case is the desired standard attenuation and in the second case corresponds to what is actually measured. The difference in the substitution losses in the two cases is the error ϵ_S . It can be resolved into three components ϵ_I , ϵ_{II} , and ϵ_{III} , which can be written as follows:

$$\epsilon_I = (A_D - A_H) + (A_P - A_A) + (A_Q - A_C), \quad (10)$$

$$\epsilon_{II} = 20 \log_{10} \left| \frac{(1 - p_{22}b_{11})(1 - b_{22}q_{11}) - p_{22}b_{12}b_{21}q_{11}}{1 - p_{22}q_{11}} \right|$$

$$- 20 \log_{10} \left| \frac{(1 - a_{22}b_{11})(1 - b_{22}c_{11}) - a_{22}b_{12}b_{21}c_{11}}{1 - a_{22}c_{11}} \right| \quad (11)$$

$$+ 20 \log_{10} \left| \frac{1 - p_{22}q_{11}}{1 - a_{22}c_{11}} \right|, \text{ and}$$

$$\epsilon_{III} = 20 \log_{10} \left| \frac{(1 - {}^f S_{11} \Gamma_G)(1 - {}^f S_{22} \Gamma_L) - {}^f S_{12} {}^f S_{21} \Gamma_G \Gamma_L}{1 - \Gamma_G \Gamma_L} \right|$$

$$- 20 \log_{10} \left| \frac{(1 - h_{11} \Gamma_G)(1 - h_{22} \Gamma_L) - h_{12} h_{21} \Gamma_G \Gamma_L}{1 - \Gamma_G \Gamma_L} \right| \quad (12)$$

Note that ${}^f S_{11}$ refers to a scattering coefficient of the final composite waveguide junction in system N . It is composed of two-ports P , B , and Q connected in cascade. Other scattering coefficients of this final waveguide junction are similarly designated.

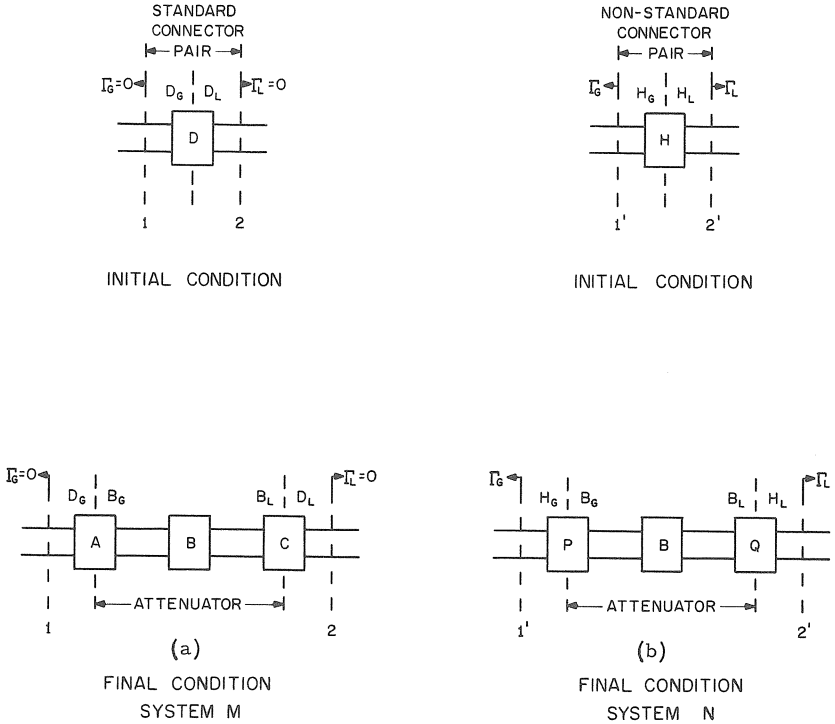

FIGURE 7. Representation of same attenuator installed alternately in two systems.
 (a) System M nonreflecting and joined with a standard connector pair.
 (b) System N has reflections and is joined with a nonstandard connector pair.

The error component ϵ_I consists of differences of attenuations of connector pairs and will vanish if corresponding connectors $D_G \equiv H_G$ and $D_L \equiv H_L$, since it then follows that $D \equiv H$, $A \equiv P$, and $C \equiv Q$. This is a sufficient but not necessary condition, since ϵ_I will vanish also when $A_D + A_P + A_Q = A_H + A_A + A_C$. Usually the corresponding connector pairs D and H will be similar, so that ϵ_I may be less than 0.01 decibel (dB). Evidently, it is desirable to make D and H identical, or in other words to use standard connectors at the insertion point.

The error component ϵ_{II} consists of terms similar to eq (5). It is the difference between the insertion losses of the attenuator kernel B if installed alternately into two nonreflecting systems in which the connector pairs A , C , P , and Q had reflections. This is a hypothetical situation, and one in which identity of the corresponding connectors $D_G \equiv H_G$, and $D_L \equiv H_L$ would also cause ϵ_{II} as well as ϵ_I to vanish. Since ordinarily the connector pairs at the insertion point are quite close to standard connectors, this error component will normally be small (of the order of 0.001 dB or less).

The error component ϵ_{III} differs from the other components in that it does not necessarily vanish if $D_G \equiv H_G$ and $D_L \equiv H_L$. However, it will vanish if the system reflection coefficients Γ_G and Γ_L vanish.

It is the most significant of the error components and may well exceed 0.01 dB if the VSWR of the system exceeds 1.02. The vanishing of Γ_G and Γ_L is a sufficient but not a necessary condition for the vanishing of ϵ_{III} . This is apparent since the two terms may cancel due to fortuitous amplitude and phase relationships of the scattering and reflection coefficients involved.

The above analysis reduces to the usual analysis [6, 7, 8] for mismatch error using a simpler model, if we assume that the connectors are all nonreflecting, lossless, and introduce no phase shift. In this case ϵ_I and ϵ_{II} vanish, and ϵ_{III} reduces to [7].

$$\epsilon_M = 20 \log_{10} \left| \frac{(1 - b_{11}\Gamma_G)(1 - b_{22}\Gamma_L) - b_{12}b_{21}\Gamma_G\Gamma_L}{1 - \Gamma_G\Gamma_L} \right|. \quad (13)$$

In order to facilitate rapid estimates of mismatch error, eq (13) has been used to obtain the graph of figure 8. It is assumed that the magnitudes of the system reflection coefficients Γ_G and Γ_L are equal, and that the attenuator is symmetrical, and has an attenuation greater than 20 dB. It is seen that this error can easily reach 0.1 dB if the VSWR of the attenuator is 1.15 and the VSWR of the system is also 1.15. Thus the mismatch error is quite important and must be carefully considered and reduced if accurate results are to be obtained.

Corresponding errors in the calibrations of variable attenuators are important and have been analyzed [8, 9].

In summary, one observes that two sources of error can be controlled and reduced to small amounts (1) by making the connector pair at the insertion point a standard connector pair, and (2) by reducing the magnitudes of the system reflection coefficients Γ_G and Γ_L to very small values. It is also helpful to choose attenuators for calibration which have small reflections.

2.9. Intrinsic Attenuation

Although not a very useful concept from a practical point of view, the intrinsic attenuation [10, 11] of a two-port is interesting and will be discussed for completeness.

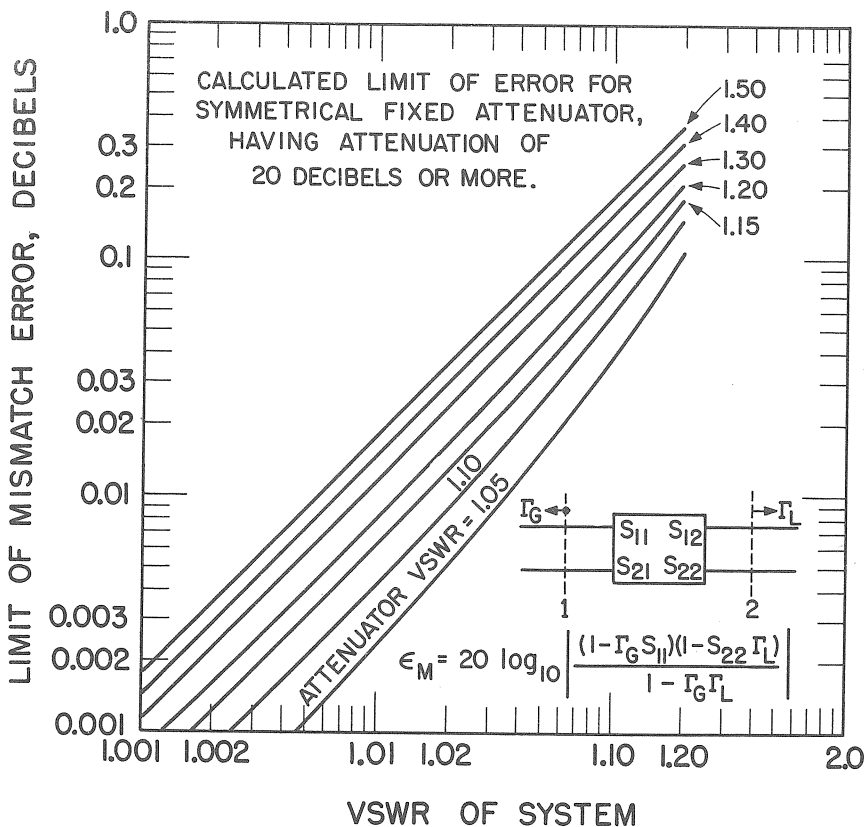

FIGURE 8. Graph for rapid estimates of limits of mismatch error.

The intrinsic attenuation can be defined as the attenuation of three two-ports in cascade; the inner two-port represents the attenuator and the other two represent lossless tuners that have been adjusted to eliminate reflections ($S_{11} = S_{22} = 0$ for the composite two-port). The fact that it is always possible to make such an adjustment is seen by considering what has been called [12] the "modified Wheeler network." The intrinsic attenuation is never greater than, and usually less than, the attenuation of the two-port representing the attenuator. Hence, it should be possible to reduce the attenuation by the use of tuners as described above. However, in a practical situation, it may be found that the losses added due to dissipation in the tuners may exceed the expected reduction in attenuation.

Another way of defining the intrinsic attenuation of a two-port makes use of its efficiency η , the ratio of net power output to net power input. The efficiency depends upon the reflection coefficient Γ_L of the load and will be maximum η_M for a particular value Γ_M of Γ_L .

The intrinsic attenuation A_I is then given by

$$A_I = 10 \log_{10} \frac{1}{\eta_M}, \quad (14)$$

where

$$\eta_M = \frac{Z_{01}}{Z_{02}} \cdot \frac{|S_{21}|^2(1 - |\Gamma_M|^2)}{|1 - S_{22}\Gamma_M|^2 - |(S_{12}S_{21} - S_{11}S_{22})\Gamma_M + S_{11}|^2}, \quad (15)$$

and

$$\Gamma_M = \frac{B}{2A} \left[1 \pm \sqrt{1 - \left(\frac{2|A|}{B} \right)^2} \right], \quad (16)$$

where $A = S_{22} + S_{11}^*(S_{12}S_{21} - S_{11}S_{22})$, and $B = 1 - |S_{11}|^2 + |S_{22}|^2 - |S_{12}S_{21} - S_{11}S_{22}|^2$.

It is evident that for a reciprocal two-port the intrinsic attenuation is the same regardless of the direction of energy flow through the two-port. However, for a nonreciprocal two-port, there will be two different intrinsic attenuations, one for each direction of energy flow.

3. Standards of Attenuation

3.1. Power Ratio Standards at D-C and Audio Frequencies

Power ratio standards developed at d-c and audio frequencies are not only important at these frequencies but are useful at much higher frequencies where substitution devices and techniques have been developed. Devices such as barretter detectors accurately follow a square-law response over a useful range and permit one to measure ratios of microwave signal levels by referring to audio frequency or to d-c ratio standards.

a. Power Ratio Standards at D-C

Although attenuators or resistive voltage dividers [13] which operate at d-c are commercially available, they are not as widely used as potentiometers. The potentiometer has been highly developed and is a versatile instrument that is available in most laboratories.

In order to determine d-c power with a potentiometer, one ordinarily measures the current through a resistor of known value. The uncertainty in making such a power measurement is ordinarily small. For example, the current may be obtained by measuring the voltage across a standard resistor of one ohm (known to 0.001 percent). If a voltage of 9.0 mV is measured with a potentiometer, the uncertainty may be 0.01 percent. Consequently, the uncertainty in the measurement of a current of 9 mA is 0.011 percent. The corresponding uncertainty in determining the d-c power (16.2 mW) dissipated in a 200-ohm resistor, known to an uncertainty of 0.01 percent, is 0.032 percent. The uncertainty in determining d-c power ratios would then be 0.064 percent or 0.0028 dB.

Somewhat lower uncertainties [13] may be obtained with commercially available equipment of higher quality. An order of magnitude improvement is possible (0.0064 percent, or 0.00028 dB in power ratio).

b. Power Ratio Standards at Audio Frequencies

Inductive voltage dividers or ratio transformers have been developed as standards of voltage ratio at audio frequencies. Commercially available units may have a typical ratio uncertainty of 0.001 percent + 0.0006 percent ÷ ratio. Variations of the uncertainty calculated from this

formula are shown in table 1. For ratios near unity or below 1 dB, the uncertainty remains at 0.0016 percent or 0.00014 dB. At lower ratios, the uncertainty continues to rise, reaching 0.6 percent or 0.052 dB for a ratio of 0.001 or 60 dB.

The inductive voltage divider is usually quite stable and can be calibrated [14] in order to obtain somewhat greater accuracy. Perhaps an order of magnitude decrease in the uncertainties in voltage ratios quoted in table 1 is possible. Calibration of these inductive voltage dividers may be carried out with respect to capacitance standards, [15] or by other methods [16] which have been recently developed.

The frequency range of most commercially available inductive voltage dividers is 30 to 1,000 Hz, and some will operate at 20 kHz.

TABLE 1. *Typical uncertainty in the ratio of a commercially available inductive voltage divider*

Ratio	Ratio in decibels	Uncertainty	
		Percent	Decibels
0.900	0.9152	0.00166	0.00014
.500	6.0206	.0022	.00019
.100	20.000	.0070	.00061
.010	40.000	.061	.0053
.001	60.000	.601	.052

3.2. Broadband Attenuators

At frequencies above approximately 1 kHz, most inductive voltage dividers become less accurate due to capacitance effects, and broadband drum-type attenuators are used as standards. Carbon-film, π -section attenuators having 0.1-dB steps have been made [17] that do not exhibit much change in attenuation from d-c to 1,000 MHz. For frequency changes from 0 to 200 MHz, corresponding changes in attenuation were less than 0.1 dB and up to 1 GHz were less than 1 dB.

In addition, metallic film attenuators are commercially available which operate from d-c to microwave frequencies. Some of these are quite stable and are available in drum-type attenuators having 0.1-dB steps and a range of 0 to 64 dB. They have a frequency range from d-c through 2 GHz and an uncertainty, when calibrated, of 0.02 dB per 10 dB, or 0.02 dB, whichever is greater. It is possible to obtain specially selected single attenuators of this type which operate up to 12.4 GHz and calibrate them to higher accuracy; but at frequencies of approximately 10 MHz to 1 GHz, higher accuracy can be obtained with waveguide-below-cutoff attenuators.

3.3. Waveguide-Below-Cutoff Attenuators

a. General Considerations [18]

A waveguide section, excited in one mode by a sinusoidal signal at a frequency below cutoff, has an exponential decay of field strength along its axis. The rate of decay may be closely predicted from a knowledge of the cross-sectional dimensions of the waveguide. A moving probe which couples to the field will therefore have a predictable output variation. The entire arrangement constitutes a standard of attenuation.

Practical waveguide-below-cutoff attenuators are usually made from metal tubes of circular cross section and operated in the $TE_{1,1}$ mode.

(Rectangular cross section is also used and has the advantages that there is greater separation between the cutoff frequencies of higher modes and the attenuation rates are relatively greater for the unwanted modes.)

For a perfectly conducting waveguide of circular cross section of radius r , and having a $TE_{1,1}$ mode cutoff frequency f_c , the attenuation rate when operating at frequency f below cutoff is:

$$\alpha = \frac{15.99}{r_{cm}} \sqrt{1 - \left(\frac{f}{f_c}\right)^2} \text{ decibels per centimeter,} \quad (17)$$

where

$$f_c = \frac{55.20}{2\pi r_{cm}} \text{ GHz.} \quad (18)$$

A graph of eqs (17) and (18) for a limited range of r is shown in figure 9. It has been assumed in plotting the curves that the operating frequency is well below cutoff so that the term $(f/f_c)^2 \ll 1$, and can be neglected.

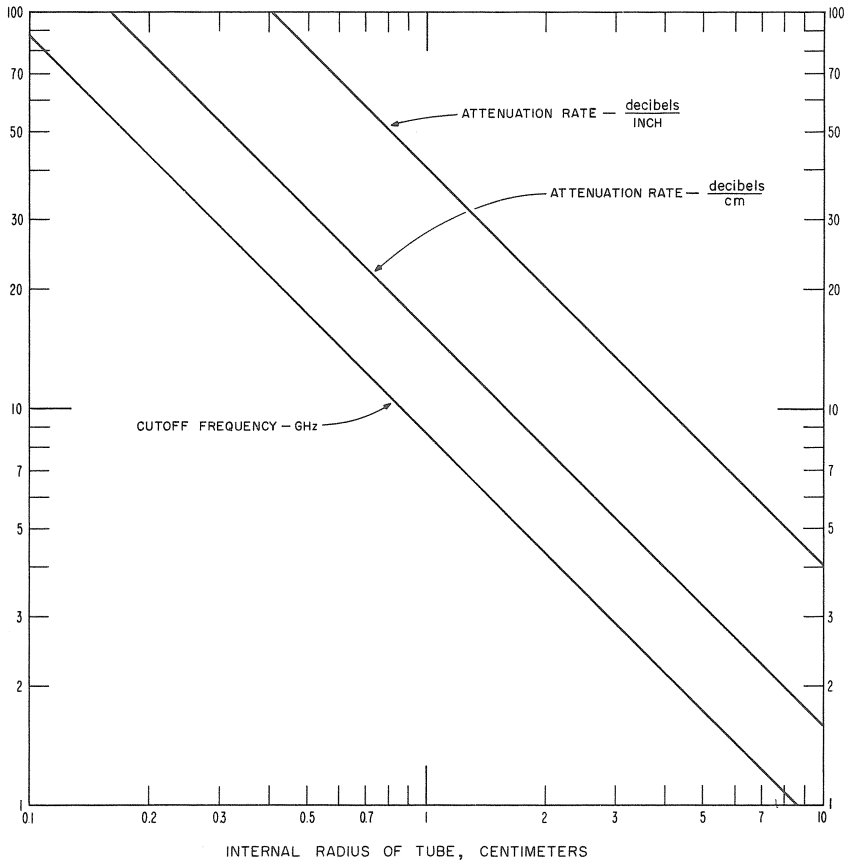

FIGURE 9. Cutoff frequencies of perfectly conducting tubes of circular cross section, and their well below-cutoff attenuation rates plotted versus the internal radius in centimeters.

It is advantageous to operate well below cutoff to reduce errors in the attenuation rate due to any possible uncertainty in the frequency.

As one goes to higher frequencies, it is necessary to use tubes of smaller radii in order to stay below the cutoff frequency, as seen from eq (18). It is seen that this will result in an increased attenuation rate according to eq (17). For a given tolerance in the radius, and for a given uncertainty in measuring the displacement of the pickup coil, the errors will increase. For this reason, the waveguide-below-cutoff attenuator has not been used as a precise standard of attenuation much above 1 GHz, although it has been used for direct reading variable attenuators up to 11 GHz, in applications where an accuracy of ± 2 dB is considered satisfactory.

As one goes to lower frequencies, the skin depth becomes appreciable compared to the wall thickness, and waveguide-below-cutoff attenuators are seldom used below 1 MHz. The skin depth in brass at 1 MHz is approximately 0.005 in. The wall thickness should be much greater than the skin depth if leakage through the tube [18n] is to be negligible.

A desirable characteristic of waveguide-below-cutoff attenuators is that the phase shift does not change as one varies the attenuation over the linear range.

When used as a variable attenuator, the below-cutoff attenuator has the disadvantages of almost purely reactive input and output impedances and a high residual attenuation of 20 to 30 dB. The large residual is due to the fact that the attenuation rate is not accurately predictable when the separation of the pickup and exciting coils is too small. This minimum spacing is dependent upon both loading effects and the presence of higher modes (to be discussed).

b. Dimensional Tolerances and Accuracy of Measurement of Displacement

The dimensional tolerances on the internal radius of the tube are important. For example, a tube having a nominal radius of 0.80 cm has an attenuation rate well below cutoff of approximately 20 dB per centimeter. In order to keep the uncertainty in the attenuation rate to within 0.002 dB per centimeter, the radius must be held to the nominal value to within 0.000080 cm, or 0.000032 in. Thus, close tolerances must be held in the fabrication of the tube, and electroforming techniques are often used. In addition, machining and honing of stainless steel cylinders have been carried out [18n].

At higher frequencies of operation, this problem becomes more critical. At an operating frequency of 30 MHz, a tube radius of 2.9 cm might be used, with an attenuation rate of 5.5 dB per centimeter. Assuming an uncertainty of 0.001 cm in the radius, the corresponding uncertainty in the attenuation rate would be 0.0019 dB per centimeter. This would result in an uncertainty of ± 0.019 dB in a measurement of 55 dB.

The same 0.001 cm uncertainty in a radius of 2.9 mm, for a tube operating at 3 GHz would cause an uncertainty of 0.019 dB per centimeter in the attenuation rate of 55 dB per centimeter. This would increase the uncertainty of a 55 dB measurement to ± 1.9 dB.

The uncertainty in the measurement of the displacement of the pickup coil is also important. For example, if the attenuation rate is 5.5 dB per centimeter as in the case above, an error of 0.001 cm will cause a

corresponding error of 0.0055 dB at 30 MHz. At 3 GHz, with an attenuation rate of 55 dB per centimeter, the same 0.001 cm error in the measurement of displacement will cause an error of 0.055 dB.

It is clear that the dimensional tolerances on tube radius eventually limit the upper frequency at which below-cutoff attenuators are useful as standards.

c. Skin Depth Corrections

The effect of the penetration of the current into the metal walls of a waveguide is to decrease the attenuation rate by a small but appreciable amount. In a copper waveguide of circular cross section operating at 30 MHz, the skin depth is approximately 0.0005 in., and the effective radius is increased by half [18e] this amount. Thus for a tube radius of 1.6 in. the attenuation rate might be 0.00156 dB per inch lower than that predicted without accounting for the skin depth. One ordinarily corrects for this in the design of the attenuator so that only the error in determining the skin depth contributes to the uncertainty in the attenuation rate.

A nomogram [18i] is available for determining the attenuation rate of a waveguide-below-cutoff attenuator operating in the $TE_{1,1}$ mode, and taking into account the skin depth. Corresponding charts for rectangular waveguide are not available, but the effect of skin depth on the propagation constant of the dominant mode has been analyzed [18j].

d. Loading Effects

As the coupling coils are brought closer together, there is an effect on the input power due to loading of the input circuit by the circuit connected to the pickup coil. If adequate coil separation is maintained, this effect is negligible, but one pays a price of tolerating perhaps 30 dB of initial attenuation. This limits the range over which attenuation measurements can be made with the IF substitution technique.

Several approaches have been made to reduce the initial attenuation or its effect in limiting the range of accurate measurement. Two different analyses [18h], giving different results, are available to determine the effects of loading. These effects are avoided by using a feedback system to provide constant current to the exciting coil [18k]. Another approach is to employ a separate source of energy at the intermediate frequency to excite the below-cutoff attenuator, and to switch between the attenuator output and the output of the mixer in the IF substitution system [18c]. This removes the below-cutoff attenuator from the circuit between mixer and detector and effectively increases the range of the measurement by the amount of the initial attenuation of the below-cutoff attenuator.

e. Mode Purity

In exciting the waveguide-below-cutoff attenuator, one attempts to excite only the desired mode, but unless unduly elaborate exciting arrangements are used, other modes will also be excited. The higher modes will have somewhat higher attenuation rates than the desired mode. Thus for large probe separations, the higher modes will have

decayed faster than the desired mode and will have negligible effect on the output. One does not usually rely on this effect to obtain mode purity, but instead uses mode filters [18e] to attenuate the higher modes. The thickness of the mode filter then limits the closeness of separation of the exciting and pickup coils, and this in turn limits the minimum or residual attenuation of the below-cutoff attenuation standard.

The possibility of rotation of the polarization of the desired mode should be reduced by careful fabrication of the tube to avoid any eccentricity. This can easily be checked experimentally for a given tube.

3.4. Rotary Vane Type Attenuators [19]

The type of variable attenuator in which a dissipative resistive vane is rotated in a section of waveguide of circular cross section has one of the properties essential for a standard attenuator. That is, the incremental attenuation can be accurately determined by calculation from the angle that the vane makes with the polarization of the $TE_{1,1}$ mode in the waveguide.

In addition to its possible use as a standard attenuator, this type has found wide use as a direct reading variable attenuator.

The attenuation is given [19d] by the expression

$$A = (40 \log_{10} \sec \theta + C) \text{dB}, \quad (19)$$

where θ is the angle of the central vane with respect to the normal to the plane of polarization of the electric field in the $TE_{1,1}$ mode, and C is a constant representing the residual attenuation when $\theta=0$. Tables based upon eq (19) are available [19h] to determine the variable component of attenuation as a function of the vane angle θ .

Errors in the incremental attenuation as given by the dial reading are usually small but are appreciable and are caused by a number of factors, such as mismatch, drive gear imperfections, misalignment of end vanes, initial misalignment of central vane, insufficient attenuation of central vane, mode impurity in central section, perturbation of $TE_{1,1}$ fields by the vane, imperfections in the rotating chokes, parallax in the readout device, mechanical flexure of the end vanes during connection of the attenuator in the circuit, warping of the vane, etc.

Practically all of these errors have been investigated except for some alignment problems and perturbation of the field by the central vane.

The results [20] shown in table 2, if they can be considered typical, are a tribute both to the original concept upon which the attenuator is based, and the design and construction of commercially available attenuators. At present, the rotary vane attenuator is available in many sizes of waveguide operating from 2.6 to 220 GHz.

At frequencies from 2.6 to perhaps 170 GHz, the waveguide-below-cutoff attenuator operating at 30 GHz (or 20 to 60 GHz) in an IF substitution system will probably continue to be used to calibrate rotary vane attenuators. Somewhat greater resolution and accuracy are available [20] with reference to d-c standards, but the method is presently not as convenient as the IF substitution technique. The modulated subcarrier technique appears promising as a competitor, but comparable confidence has not yet been developed.

TABLE 2. Results of three sets of measurements on a rotary vane attenuator

Attenuator dial reading	Average of measured values
<i>Decibels</i>	<i>Decibels</i>
0.01	0.0107
.02	.0214
.03	.0303
.04	.0407
.05	.0521
.06	.0609
.07	.0700
.08	.0802
.09	.0909
.1	.1021
.12	.1191
.14	.1375
.16	.1573
.18	.1783
.2	.2007
.25	.2471
.5	.4979
1	1.004
2	1.996
3	2.998
5	4.990
10	9.965
15	14.99
20	19.95
25	25.01
30	30.07
40	40.33
50	52.24

4. Types of Attenuators Suitable for Calibration

4.1. Criteria for Suitable Attenuators

Not all types of attenuators are suitable for calibration for various reasons. They should meet the following criteria:

1. Electrical characteristics should be stable over long periods of time (several years).

2. They should be mechanically stable and rugged so as not to undergo any permanent changes of characteristics under careful handling and shipping.

3. Changes of electrical characteristics with changes of environmental conditions such as temperature, pressure, humidity, etc., should be small (less than 0.01 dB over ranges encountered in various laboratories).

4. Changes of electrical characteristics with power level should be small (less than 0.01 dB over ranges used).

5. Reflections should be small (VSWR certainly less than 1.5, preferably less than 1.15).

6. Leakage should be negligible.

4.2. Coaxial Attenuators

Sections of lossy cable such as RG-21/U have been used as attenuation standards. These are especially attractive when average powers of 10 watts or higher are encountered. However, unless special precautions [21] are taken to eliminate flexure of the cable, especially near the connectors, they are not ordinarily suitable for precise work.

Both T and π configurations are used to construct attenuators in coaxial line. The elements are rods and discs with a resistive film of graphite or metal baked on an insulating base, then covered with a protective insulating film. Such attenuators have been highly developed to have stable characteristics and low reflections over frequency ranges from d-c to 12 GHz.

Coaxial attenuators having only resistive center conductors may also be suitable for calibration over a limited bandwidth, for example 2 to 18 GHz.

Extremely broadband coaxial attenuators have recently been built using a resistive card [22] as the lossy element, and attaching leads to certain points on the card. They are useful at frequencies from 0 to at least 18 GHz.

The use of in-line directional coupler types of standard attenuators is an anticipated development which should result in standard coaxial attenuators having superior characteristics.

Ordinarily, coaxial pads can be easily checked at d-c to see whether there is any defect which would make them unsuitable for calibration at higher frequencies.

Coaxial variable attenuators have been constructed using stripline and rotating discs of resistive material, hybrid or ring circuits in stripline with sliding contacts, and sliding contacts on resistive cards. A capacitively coupled metal slider, shorting out portions of a resistive center conductor has been used. Variable directional coupler types of coaxial attenuators have been very successful. In addition, flap-type variable attenuators have been built in coaxial line. The waveguide-below-cut-off attenuator has also been used as a basis for a variable coaxial attenuator. Very few of these designs have met the criteria for a good standard variable attenuator, so that more development needs to be done in this area.

4.3. Attenuators in Rectangular Waveguide

Both fixed and variable attenuators are available in rectangular waveguide which are suitable for calibration.

The type of fixed pad having best characteristics for a standard is the in-line directional coupler [23] and related types. True in-line arrangements can be calibrated more accurately than offset "in-line" arrangements. Fixed pads have the disadvantage that they must be inserted and removed from the circuit during the calibration.

Single-step attenuators are available in which the in-line directional coupler principle is used. A movable resistive vane is positioned in the main waveguide between the two sets of coupling holes of an in-line directional coupler. When the vane is flat against the wall of the waveguide, energy passes through the main waveguide with very little loss. When the vane is moved out into the electric field, it attenuates effectively all of the energy which tends to pass through the main waveguide.

In this case only the energy which passes through the coupling holes into the auxiliary waveguide and back again arrives at the output. Thus two steps are provided; an initial step having very little attenuation and a final step having an attenuation determined by the sets of coupling holes. Such an attenuator has a low VSWR, is not frequency sensitive and does not need to be removed from the circuit during calibration. However, the minimum loss position may show a small variation (less than 0.1 dB) if the vane does not lay flat ^{against} the wall each time it ^{is} so positioned.

Continuously variable attenuators of mainly two designs are suitable for calibration. These are (1) the rotary vane type, and (2) the type in which a resistive vane moves in and out of the waveguide field, remaining parallel to the side wall.

The rotary vane type has superior resolution at the lower attenuation values while some models of the parallel translating vane type have higher resolution at the higher attenuation values. The rotary vane type has much lower phase change (less than 1 degree over the entire range) and is less frequency sensitive than the other type.

Presently realizable accuracy [20] of attenuator calibration exceeds the resolution to which these "precision" attenuators can be set and read; therefore, further developments are indicated.

5. Measurement Methods

5.1. Classification of Methods

A large variety of methods is available for attenuation measurements. They can be classified as follows, according to the kind of standard used:

1. D-c substitution
2. Audio substitution
3. IF substitution
4. Direct substitution
 - a. Series
 - b. Parallel
5. Methods requiring no standard of attenuation
6. Others

Many variations on, and mixtures of methods are possible, so that the above classification scheme is not perfect. However, most of the "standard" methods will be accommodated.

Perhaps the greatest range (150 dB) has been obtained [18k] with the direct (parallel) substitution method at 30 MHz. Ordinarily up to 70 dB range is obtained using the IF substitution technique, and this may be extended at least 30 dB by use of a separate IF source [24] and switching arrangement and by combining this with direct substitution.

The greatest accuracy has been obtained using a d-c substitution technique. Although comparable precision was obtained with a modulated sub-carrier method, the error evaluation of this method is not so complete.

Audio modulation methods are convenient to use with equipment ordinarily available in most laboratories, but have limited range and accuracy. However, continued refinement of the equipment, and use of dual channel systems, synchronous detection, and noise suppressors, can markedly increase the accuracy and ranges of these methods.

Methods requiring no attenuation standard are attractive from one point of view—minimum equipment—but are comparatively tedious in operation and limited in range. However, they may be quite useful when an attenuation standard is not available.

5.2. D-C Substitution

In d-c substitution methods, some sort of converter is ordinarily used to produce a change in d-c power bearing a known relationship to the change in a-c power to be measured. The converter may be a crystal rectifier, thermocouple, bolometer, etc. The “law” of the converter must be known in order to convert from the measured d-c ratios to the desired a-c ratio. A crystal rectifier may operate in a square-law region at low signal levels, and in a linear region at high signal levels. At intermediate levels, the “law” is somewhere between the two.

It is clear that a precise knowledge of how much the converter deviates from its ideal “law” is necessary if accurate results are to be obtained.

A d-c substitution technique using bolometers (barretters or thermistors) in a balanced bridge arrangement has been described [20]. In this method, microwave power dissipated in a barretter causes a change in its d-c resistance away from its initial value corresponding to a certain d-c bias power. The barretter resistance is returned to its initial value by withdrawing some of the d-c bias power. The amount of d-c power withdrawn is nearly equal to the microwave power dissipated in the barretter. The ratio of the two powers is nearly unity. In order to measure the absolute microwave power by this method, one would need to know this ratio; but in an attenuation measurement, we need to determine only the relative power. Hence we do not need to know the ratio, but we do need to know that it is constant for a given bolometer and independent of power level over the range of observation.

The constancy of the ratio is difficult to determine absolutely, but has been investigated [25] by an experiment in which microwave power was fed through a power divider (3 dB directional coupler) to a barretter mount and a thermistor mount. The microwave power level was varied in steps over a 20 dB range, and the ratio of the d-c substituted powers in the two bolometers was noted at each step. Within the experimental error (0.1 percent) no change in the ratio was observable, indicating either that no change occurred, or that it was identical for the two elements. However, the barretter and thermistor are sufficiently different that it seems more likely that no appreciable change in the ratio occurred. Since the experimental error of 0.1 percent corresponds to 0.0043 dB, over a 20 dB range, it is reasonable to place at least this much confidence in the results of a 20 dB attenuation measurement using this d-c substitution technique. The confidence limit should be correspondingly better for attenuation smaller than 20 dB.

Actually an error of 0.1 percent $+ 0.1\mu\text{W}$ in measuring power differences can lead to errors of 0.0001 to 0.0043 dB in attenuation as the attenuation varies from approximately 0.06 to 3 dB. This follows if one measures directly the change in d-c power, $W_2 - W_1$, corresponding to a change in the microwave attenuator rather than measuring each time the departure from the initial bias power W_0 . The error evaluation procedure is illustrated in the following example:

The attenuation A is given by

$$A = 10 \log_{10} \frac{W_0 - W_1}{W_0 - W_2} \quad (20)$$

Instead of measuring $W_0 - W_1$ and $W_0 - W_2$, it is preferable for attenuations less than 3 dB to measure $W_2 - W_1$, a smaller difference. This quantity appears explicitly by rewriting eq (20)

$$A = 10 \log_{10} \frac{1}{1 - \frac{W_2 - W_1}{W_0 - W_1}} \quad (21)$$

An example will show the difference in the error in A as determined by the two methods. The character of the error in measuring differences in d-c power is such that it is partially random and partially systematic. In a particular example, it is assumed that this error has equal random and systematic components. Thus if $W_0 - W_1$ is 0.1 percent high, $W_0 - W_2$ will be between 0 and 0.1 percent high. Let $W_0 = 15.00$ mW, $W_1 = 10.10$ mW, and $W_2 = 10.64$ mW, so that $A = 0.5071$ dB. If we measure $W_0 - W_1$ with an error of 0.1 percent high, obtaining 4.095 mW, then the measured value of $W_0 - W_2$ will be between 4.3600 and 4.3644 mW. We can then obtain A as high as 0.5115 dB, or an error limit of 0.0044 dB.

Now suppose that we measure $W_2 - W_1$ with an error of 0.1 percent high, obtaining 0.5405 mW, then the measured value of $W_0 - W_1$ will be between 4.900 mW and 4.905 mW. We then can obtain A as high as 0.5076 dB, or an error limit of 0.0005 dB. Thus the error limit is reduced to approximately one ninth of the error limit which occurs when measuring $W_0 - W_1$ and $W_0 - W_2$.

For attenuations above 3 dB, one measures the d-c power differences $W_0 - W_2$ and $W_0 - W_1$, and uses eq (20).

* In using this d-c substitution method, it is recognized that other sources of error will be present, and they must have correspondingly low limits if one is to take full advantage of the high accuracies of d-c standards. One must pay close attention to the reduction of system reflections and carefully evaluate the mismatch errors. It has been found worthwhile to use this technique to calibrate rotary vane attenuators because they have quite small variations of phase shift as the attenuation is changed, have low reflections, and have high resolution over the lower part of their range.

Strictly speaking, any method in which the attenuation at some desired higher frequency is obtained by reference to d-c standards can be regarded as a d-c substitution technique. Thus the measurement of the power to a load before and after insertion of variation of the attenuator can be a d-c substitution technique provided that the power is measured by a method using d-c standards. The direct substitution of d-c attenuation for the attenuation to be measured at a higher frequency has not been so widely employed because other techniques have been easier to apply and have wider direct ranges.

5.3. Audio Substitution

Accurate standards of attenuation, such as drum-type attenuators having step intervals as small as 0.01 dB, have been available for use at audio frequencies for many years. Such standards are relatively inexpensive and are available in most measurement laboratories. In addition, accurately square-law converters such as barretters have also been available and inexpensive for many years. Consequently, audio substitution techniques of attenuation have been popular [26] in spite of the limited range (below approximately 40 dB, directly) of the converters.

Basically the method involves the following steps: modulation of the signal source or its output, square-law detection, attenuation of the audio frequency by a calibrated audio attenuator, amplification, and, finally, detection and indication.

In this substitution method, as well as all others, a basic question must be answered. That is, how much does the converter or detector deviate from the assumed law? Studies have been made [27] of barretters and crystal detectors, with the result that the range of use depends upon the tolerable deviation from square law. If 0.2 dB is tolerable, the crystal video diode can have a range of approximately 38 dB, and the barretter a range of 53 dB. However, if less than 0.01 dB is tolerable, use of a crystal is not recommended, but a barretter has a range of approximately 20 or 30 dB.

Other types of square-law detectors, such as thermistors, [28], thermocouples, bolomistors [29], ferrite [30] and ferroelectric [31] detectors, and thermoelectric films [32], have also been used.

The deviations from square-law behavior are somewhat different for each of these types of detectors. No exhaustive comparative study has been made; therefore, it is good practice to check the deviations from square law when using audio substitution techniques.

One can determine this experimentally in a given system by starting at a fairly low power level and measuring a given change of attenuation, e.g., 1 dB, at progressively higher power levels to the detector. When the observed attenuation increment changes by an amount equal to the tolerable deviation, the power to the detector is noted. If one stays below this power level, then deviations from square law will remain below the tolerable deviation. This is true because the small signal theory of crystal and barretter detectors predicts square-law behavior, and the smaller the signal, the closer one comes to ideal behavior.

The lower end of the range is limited by noise which increases approximately as $1/f$, where f is the frequency. One cannot decrease noise indefinitely by increasing f , especially with barretters, because their time constant will reduce their detection efficiency. Also, the frequency ranges of audio standards such as resistive attenuators and inductive voltage dividers are limited. Considerable reduction in the effect of noise has been achieved by using synchronous detection which effectively decreases the bandwidth.

The effects of noise on errors in attenuation measurements have been investigated [33] for different kinds of detectors. The results apply to IF substitution methods employing audio modulation as well as to audio substitution methods. Graphs are available [34] to show the increase in d-c output due to noise and the rms fluctuation of linear detector output as a function of signal-to-noise ratio at the detector input.

The range of attenuation measurements using audio substitution methods can be increased by first measuring a 20 or 30 dB fixed pad and using it as a "gage block." When measuring an attenuator of 50 dB, for example, a "gage block" of 30 dB is first inserted ahead of the detector as shown in figure 10. The "gage block" is then removed and the attenuator under test inserted in its place. The range of level change

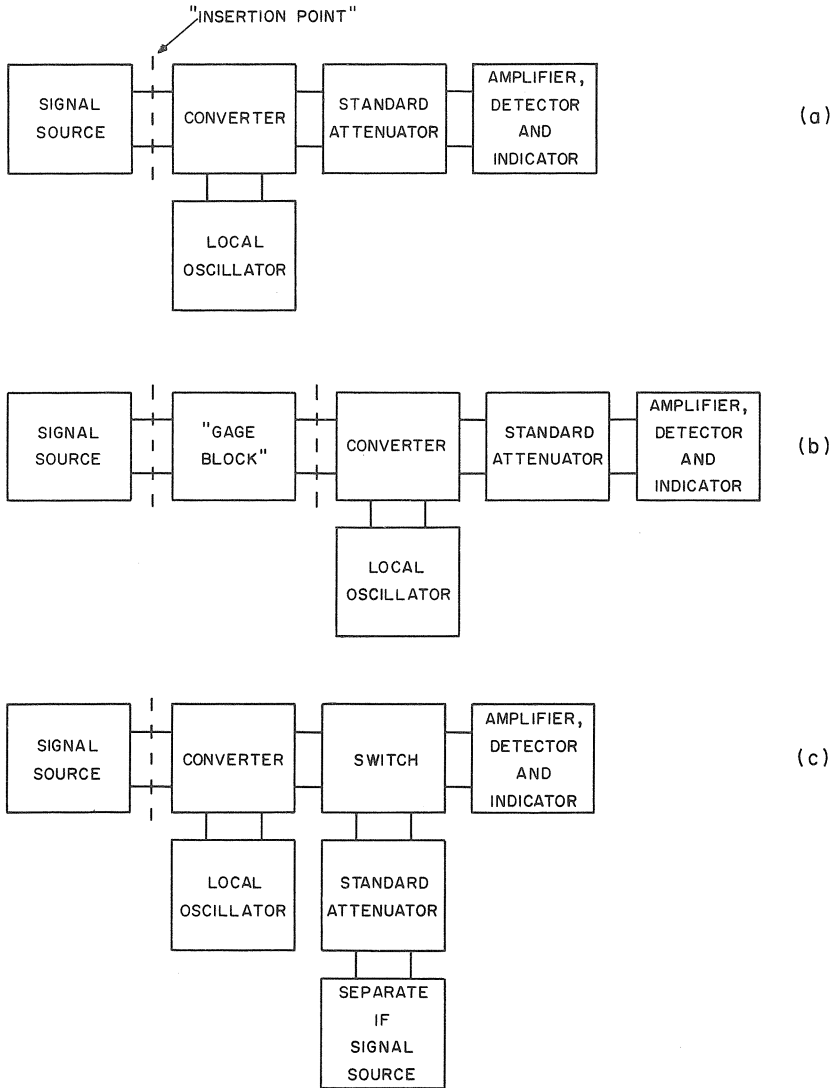

* FIGURE 10. Arrangement for extending range of attenuation measurement by using a "gage block".

(a) Standard attenuator set on maximum, indicator on reference level.
 (b) "Gage block" inserted, standard attenuator changed to set indicator on reference level, thus measuring attenuation of "gage block." Next, standard attenuator is set on maximum and signal level and amplifier are adjusted to restore indicator to reference level.
 (c) Attenuator under test is substituted for "gage block," and standard attenuator changed to restore indicator to reference level, thus measuring attenuation difference between gage block and attenuator under test.

at the converter is then only 20 dB instead of the full 50 dB of the attenuator under test. This procedure has the advantage that the square-law range of the converter is not exceeded. However, the use of the "gage block" or pad may cause additional mismatch error [35], and it is desirable to choose a pad for this purpose which has low reflections, and to reduce the reflections of the system at the insertion point.

5.4. IF Substitution

a. General Considerations

Any method which uses a superheterodyne receiver and employs a standard attenuator operating at the intermediate frequency falls within this category. It is usually understood that the intermediate frequency is above the audio range to separate this from audio substitution techniques. However, it would be possible to have an IF substitution system employing a standard at audio frequencies, but this is unusual.

A "straight" IF substitution attenuation measurement system is shown in figure 11(a), and variations of it for the purpose of improving the range are shown in figures 11(b) and 11(c). These techniques, using a "gage block" and a separate IF source and switching, have already been mentioned. In addition, audio modulation of the signal

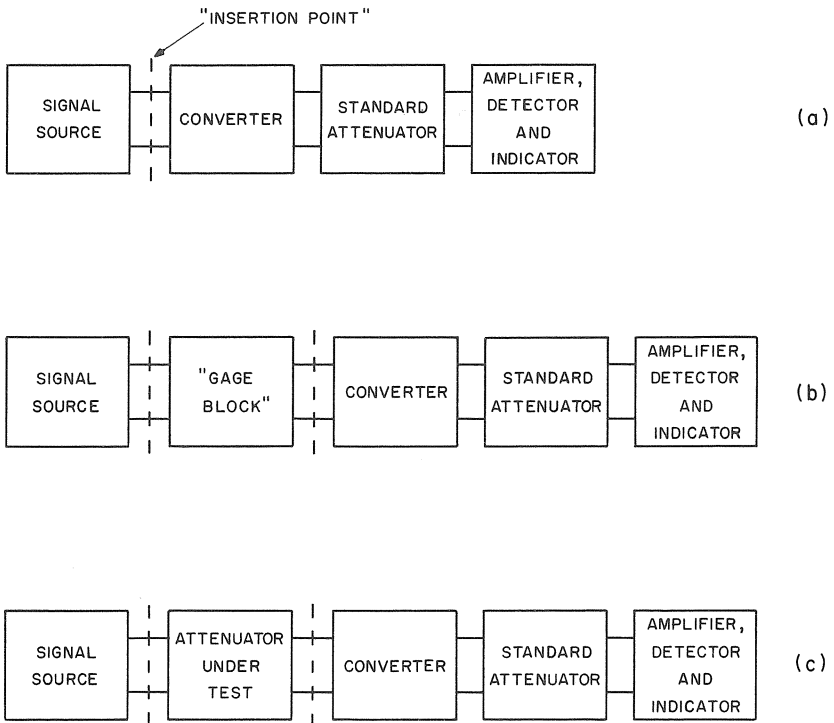

* FIGURE 11. *Basic IF substitution attenuation measurement systems.*

- (a) "straight" IF substitution
- (b) use of "gage block" attenuator
- (c) use of separate IF signal source

source output and synchronous detection are sometimes used to increase the range.

Because of its importance, the "straight" IF substitution attenuation measurement system will be discussed with particular emphasis on the analysis and reduction of errors. A system such as is shown in figure 11(a) is considered a basic one. In practice it will include isolators following the signal source, tuners on each side of the insertion point, and possibly phase locking circuits to maintain the local oscillator and signal frequencies at a constant separation frequency (the IF). Modulation of the signal source or its output will not be considered, although it is apparent that additional errors can be introduced by this modification of the basic method. If modulation is used to obtain increased range, the additional errors resulting from this practice should be evaluated and controlled.

b. Discussion of Errors

1. *Introduction*—In addition to the departure of the converter or mixer from linear power conversion, many other sources of error are present and may be significant. Unless they are all accounted for to the best of one's ability, one is not justified in placing a great deal of confidence in a precise measurement of attenuation.

Some errors are mainly systematic in nature, such that they produce the same deviation in the same direction each time that a measurement is repeated in the same system operating at the same frequency. The nonlinearity of power conversion in the mixer is an example of this.

Other errors are ordinarily systematic, but can be made random by changing or adjusting a portion of the system between measurements. An example of this is the mismatch error. One can readjust the tuners used for reduction of the system reflections between measurements, or they can be left alone. Even if left alone, a small random component may be introduced if there are slight frequency changes between measurements.

Finally, errors are present which are mainly random in nature, and their effect will diminish upon averaging the result of a number of measurements. An example of this type of error is caused by the inability of the operator to restore the output indicator exactly to the reference level after insertion or variation of the attenuator under test. One may have a small systematic component here, depending upon the way the operator looks at the output indicator.

2. *Mismatch errors*—From previous considerations which led to eqs (10), (11), and (12), it is apparent that the interaction of system reflections and reflections from the attenuator are significant sources of error in attenuation measurements using practically any method. In very precise measurements, one cannot completely separate connector errors from errors caused by interaction of reflections, and the analysis of section 2.8 applies. If the precision is not greater than 0.01 dB, and the connectors are not uniform and conform to standard specifications, then the relatively simple eq (13) applies. The mismatch errors based upon eq (13) for fixed pads, and similar equations for variable attenuators [8, 9], have been analyzed and graphs [6] are available for rapid estimates of error limits. The use of figure 8 gives an especially rapid, if perhaps too conservative, estimate of the limits of error.

It should be kept in mind that one could, in principle, determine the mismatch error and make a correction for it. However, this would require information on both magnitudes and phases of a number of reflection and scattering coefficients. Usually, one determines only magnitudes. This permits calculation of the limits between which the error must lie, but gives no idea where it actually lies between those limits. In addition, equipment such as slotted lines is limited in the accuracy with which the nonreflecting condition can be recognized. The result is that the so-called limit of mismatch error is really a conservative limit on our ability to determine how closely we have approached the desired nonreflecting condition. This is an important source of error which can quickly become the dominant one if not carefully controlled.

Attempts to eliminate mismatch error by special techniques have ^{apparently} not yet been successful [36]. *

3. *Converter errors*—The power conversion linearity of the mixer or converter is of basic importance, and it is well known that appreciable deviations can occur if special precautions are not observed. Investigations have shown that the deviations from linear power conversion are reduced when the signal level in the mixer is reduced relative to the level of the local oscillator power. It has been determined experimentally that for a range of at least 80 dB, such deviations remain less than 0.01 dB if the signal power in the mixer is always at least 30 dB below the local oscillator power in the mixer.

Some analysis of this error has appeared [37, 38] but additional work will be needed if all other sources of error in this method are reduced to the point where 0.001 dB is a significant amount of error.

If the system has sufficient stability, resolution, and repeatability, one can experimentally investigate the deviations from linear power conversion by repeating the measurement of the same increment of attenuation, e.g., 1 dB, at progressively increasing power levels. The results of such an experiment would be valuable even (or especially) if such deviations were too small to be detected by the system due to its other imperfections. If this were the case, no further information about the linearity of power conversion would be required for that system.

Additional errors associated with the converter might be caused by: (1) instability of the local oscillator signal level and frequency, causing fluctuations in the conversion loss of the mixer; (2) pulling of the local oscillator by load changes due to varying the rf attenuator (this normally is not serious but can occur if there is insufficient isolation between local oscillator and signal inputs to the mixer); (3) instability of the crystal current (This is normally not serious but can occur if the crystal or any part of the path of its d-c current is not stable.).

4. *Instability of signal source*—It is well known that because of frequency-sensitive components such as tuners in the system, frequency instability of the source will cause fluctuations of the output level of the system. Without phase locking of the frequency, the output fluctuations of the system caused by signal source instability can be held to ± 0.02 dB. This requires stabilized power supplies and may require water cooling [39, 40] of the oscillator. It has been found that phase locking of the oscillator to a stable source operating at a lower frequency will permit holding the system output level fluctuations to within ± 0.002 dB.

* See Errata Sheet in front of book

The system output fluctuations are important because they limit the ability of the operator to return the output indicator to the reference level. He must do this twice in an attenuation measurement, so that system output fluctuations of ± 0.002 dB could, under the most unfavorable conditions, cause an uncertainty of ± 0.004 dB. Since this is mainly a random error, the accuracy of the average of a number of readings might be considerably better.

5. *RF leakage* [41]—Usually a small amount of rf energy will reach the mixer from paths other than directly through the attenuator under test. Leakage can occur from imperfectly shielded signal sources and isolators, from components, cables, and from joints or connectors. It will add vectorially to the desired signal and will affect the measured attenuation within the limits shown in table 3.

Leakage effects are usually not observed when measuring attenuation less than 40 dB. They may become troublesome at higher values because the attenuation to be measured reduces the signal to the mixer by that amount from its initial value (see fig. 11). However, if a small step of a variable attenuator set near its maximum attenuation is measured, a large amount of attenuation may be present in both the initial and final settings of the system. If the leakage adds directly to the signal for one setting and is changed only in phase so as to subtract for the other setting, a maximum error will result which is double the error given in table 3. The data in table 3 is computed for the case in which the initial signal is well above the leakage but the final signal may not be.

The relationship upon which table 3 is based is [6]

$$\Delta P = 20 \log_{10} \frac{|E_S| \pm |E_L|}{|E_S|} = 20 \log_{10} \left(1 \pm \frac{|E_L|}{|E_S|} \right)$$

where $|E_S|$ represents the signal level, $|E_L|$ represents the leakage level, and ΔP is the limit (in decibels) of the effect upon the attenuation measurement.

TABLE 3. *Effect of rf leakage on measured attenuation*

Ratio in decibels of signal power to leakage power in mixer	Limits of effect on measured attenuation	
	<i>Decibels</i>	
10	-3.3	+2.4
20	-0.92	+0.83
30	-.28	+.27
40	-.087	+.086
50	-.027	+.027
60	-.009	+.009

If appreciable leakage is present, its effect on the output may usually be observed by moving a metal object in close proximity to the outside of the rf portion of the system. Another way to detect leakage is to progressively increase the attenuation in the rf portion of the circuit. When no further decrease is observed in the output level, the residual output is due to either leakage or noise. One can usually tell the difference by observing the character of the output signal, or by turning off the oscillator.

Perhaps the most sensitive method for detecting and locating sources of leakage is to use an auxiliary receiver having a cable and movable probe or antenna. One explores the vicinity of joints and connectors with the probe. At present, there are no really satisfactory methods to measure or specify leakage from individual sources. Thus the reduction of leakage from a system is usually accomplished by a tedious process of elimination which ends when the leakage effects are no longer observed.

One method used to indicate a reduction of leakage is to record the system output on a sensitive recorder. Output variations will result from system instabilities and also from leakage fluctuations caused by movement of personnel in the vicinity. When personnel movement has no further effect on output variations (as determined by personnel temporarily leaving the room), leakage is probably at least 20 dB below signal level.

It is usually necessary to place oscillators in shield cans, use gaskets at joints, and to wrap leaking components with steel wool or metal mesh, when measuring high attenuations.

Errors caused by leakage can have both systematic and random components, but can be made more random by varying the phase of the leakage in some way from one measurement to another. One way would be to make a number of measurements, each at a slightly different frequency from the desired frequency. Also, a line stretcher might be used to change the phase of the energy reaching the mixer via the desired path through the attenuator.

6. *IF leakage*—Leakage in the IF portion of the system is usually not as bad a problem as in the rf portion. This is not because the loss in the path is not as great, but because the openings which permit leakage are smaller compared to a wavelength. However, any IF leakage that does occur is usually more difficult to detect or eliminate and can cause errors at higher attenuations. It is also good practice to reduce IF leakage so as to reduce interference from (or to) nearby systems which may be operating at the same frequency.

7. *Errors in standard attenuator*—The errors in the standard attenuator are basic and have been discussed previously in section 3.3. Experience with various methods of attenuation measurement leads to the conclusion that with sufficient refinement of design, construction, and operation of the waveguide below cutoff attenuator, the uncertainty of the average of five attenuation measurements can be less than 0.001 dB at 20 dB. With little or no refinement, the corresponding uncertainty could have been as much as 2.0 dB. This indicates that considerable attention must be paid to the waveguide below cutoff attenuation standard if one is to have confidence in its calculated attenuation rate given by eq (17).

8. *Noise*—As long as the signal levels in the system are at least 10 dB above the noise, as is usually the case, the noise does not contribute significantly to uncertainties in attenuation measurement. However, when large attenuations are to be measured, one inserts a large amount of IF attenuation and sets the output signal to a reference level near the noise level. This noise may originate within the IF amplifier, the mixer, the local oscillator, or the signal source.

In the "straight" IF substitution system, the unknown and the standard attenuators are varied so as to present the same signal level to the IF amplifier. Thus if the noise originates mainly within the IF ampli-

fier, there will be little effect on the measured attenuation other than to decrease the resolution with which the reference level can be reset, and thereby decrease the precision of the measurement. Systematic effects have been noted [42] by some observers.

If the noise originates mainly within the mixer, it will have its greatest effect on the output when the IF attenuator is set to the least attenuation, and least effect when it is set to the greatest attenuation during a measurement. In making a measurement of 20 dB or more, the reference level will be obtained from amplified signal and noise in one case, and amplified signal in the other. Less signal will be required when noise is present, so that the IF attenuation change will be less than the rf change. The result is that the measured rf attenuation will be low.

If the noise originates mainly in the rf portion of the circuit, it will tend to remain fairly steady as the rf attenuator varies and should have a similar effect to noise originating within the mixer.

If noise originating within the local oscillator is troublesome, its effect can be diminished by using a balanced mixer. As with audio substitution, synchronous detection at the intermediate frequency can reduce the effect of noise considerably.

9. Errors from connectors or waveguide joints and from waveguide or cable—It was mentioned earlier (sect. 2.7) that the desired quantity in an attenuation measurement is the substitution loss in a nonreflecting system which is initially joined at the insertion point by a standard connector pair or adapter. If the connector pair at the insertion point is not standard, an error is introduced which has been analyzed [7]. This error is normally less than 0.1 dB, for ordinary connectors and is probably less than 0.01 dB for high-precision connectors.

Errors caused by slightly nonstandard waveguide at the insertion point are difficult to assess, but have been experimentally found to be negligible (less than 0.001 dB) in practical cases.

Flexible cable or waveguide is ordinarily not used at the insertion point or elsewhere in the rf portion of the system. When flexed, the phase shift through the cable changes and the interaction of reflections may cause amplitude changes large enough to result in serious errors. Changes in the dissipative losses in the cable when flexed may cause similar errors. At frequencies of approximately 100 MHz and below, loops of flexible cable are used to minimize flexing and these undesirable effects are largely avoided by this technique. However, at higher frequencies it becomes increasingly difficult to avoid flexing effects. Above approximately 6 GHz, leakage is such a serious problem that use of flexible cables is rare.

When the attenuation measurement requires the insertion and removal of an attenuator, it is necessary to move a portion of the rf system such as the local oscillator and mixer assembly. In order to facilitate this motion, flexible cables are used in the IF and the d-c portions of the circuit, where they ordinarily cause no trouble.

10. Errors associated with the device under test—The characteristics of the device under test definitely affect certain sources of error in its measurement. For example, mismatch error depends upon the reflections from the device under test. If we knew that the system had no reflections at all, the mismatch error according to eq (13) would vanish regardless of the reflections from the device under test. In practice, this is not the case, so that given the same system, lower limits will be

obtained for the uncertainty of attenuation measurement of a device having low reflections than for one having higher reflections.

A pad which is not stable, or has poor quality connectors, may have a different loss each time it is measured. Similarly, a variable attenuator may not be capable of repeating the same step in attenuation due to mechanical defects or other difficulties. Unless these effects are noted, the operator may mistakenly attribute them to his system rather than to the device under test.

11. Overall error—It should be apparent that it is difficult to quote reliable limits for the uncertainty of attenuation measurements with a given system. The quoted limits of error should vary with the amount of the attenuation being measured, gradually increasing at the extreme ends of the range. Also, since the characteristics of the device under test influence the errors, limits on these characteristics should be quoted.

In some cases, the uncertainty limits quoted for calibrating attenuators are sufficiently conservative so that they are seldom exceeded. In other cases, it is implied, but not stated, that the devices under test must meet certain requirements and have certain characteristics.

It appears that the best way to compare different attenuation measurement systems is to use them to measure the same attenuators at the same frequency and under similar conditions. This has the disadvantage that similar systematic errors in the systems will not be revealed. For this reason, confidence in an attenuation measurement system can be increased by comparing measurements [43] of the same attenuators in systems having different systematic errors.

5.5. Modulated Subcarrier

The modulated subcarrier technique [44, 45] bears marked similarity to ^(a)in IF substitution technique in which the signal source and the local oscillator operate at the same frequency and the signal source alone is amplitude modulated. The signals combine in a mixer and produce an output at the modulation frequency. The power conversion is very nearly linear over wide ranges of attenuation, as in the IF substitution technique, and the standard attenuator operates at the modulation frequency.

Actually one signal source is used, and its unmodulated output is split and fed to two channels as shown in figure 12. The channel containing the device under test is modulated and the modulator also excites a standard attenuator. The signals from the two channels are combined and fed to a phase sensitive detector which also receives a signal from the standard attenuator at the modulation frequency. In this version of the system, a detector null is obtained which depends upon phase and amplitude relationships at the modulation frequency.

The modulated subcarrier technique has the following advantages over the IF substitution technique: (1) only one signal source is required, (2) satisfactory audio attenuation standards are commercially available at relatively low cost, (3) the phase shift of the device under test may be determined at the same time that its attenuation is being measured, and (4) a higher resolution is obtained at low attenuations.

The following disadvantages tend to "balance the scales": (1) the procedure in making a measurement is less convenient; (2) the range

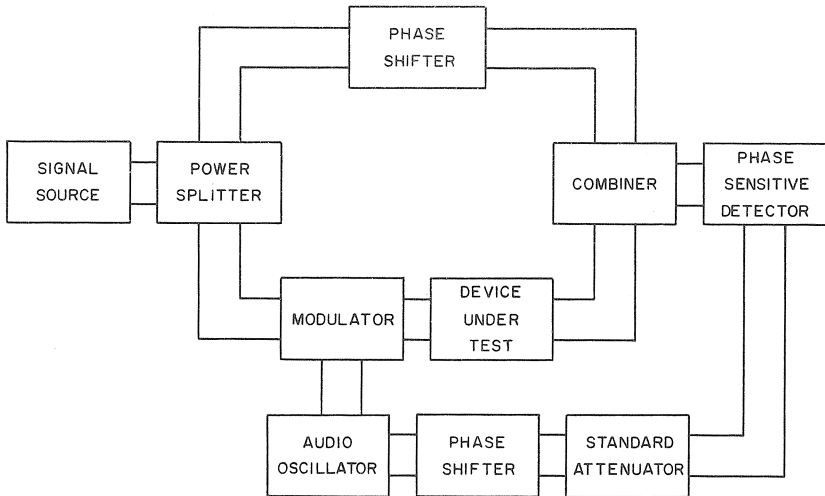

FIGURE 12. *Essential components of a modulated subcarrier attenuation measurement system using null detection.*

of attenuation measurement is presently not as great as with an IF substitution system having a separately excited IF attenuator and using modulation and a phase sensitive detector; (3) additional sources of error are present; (4) the apparatus is more difficult to set up and adjust; and (5) leakage control is more difficult.

It should be noted that although the attenuation is measured with reference to an audio standard, the phase shift is measured with reference to a calibrated microwave phase shifter. In measuring a fixed pad, it is usually necessary to substitute in its place a section of waveguide having the same physical length. This is true when rigid components are used to construct the two-channel microwave circuit which is used. Thus the method offers more convenience in measuring variable attenuators which remain in the circuit than fixed pads.

Among the additional sources of error are the following: (1) usually some adjustment of the phase shifters is necessary during a measurement and they cause unknown amplitude changes, (2) imperfect isolation between the two channels, (3) modulator instability, and (4) ground loops and pickup at the modulation frequency.

Precisions of 0.0001 dB at 0.01 dB and 0.02 dB at 50 dB obtained by this method are comparable with the d-c substitution technique described in section 3.2. It seems well-suited for the calibration of the rotary vane type of attenuator because of the very small change of phase shift of these attenuators and because of their high resolution at the lower end of their attenuation ranges.

5.6. Direct Substitution

The measurement of attenuation by comparison with a standard operating at the same frequency is called direct substitution. Thus, the IF, audio, and d-c substitution techniques have the advantage over the direct substitution technique that the attenuation standards always

operate at a fixed frequency, no matter what frequency is chosen for the attenuator calibration. However, the direct substitution technique has other advantages, such as increased range. Three direct substitution arrangements are shown in figure 13.

The parallel substitution arrangement of figure 13(a) is often used because it offers high resolution and range, and tolerates more amplitude instability of the signal source. It does require adjustment of a phase shifter which ideally should have an unchanging loss during these adjustments.

One should not confuse this parallel substitution arrangement with that of figure 11(c), which has been called [24] parallel IF substitution.

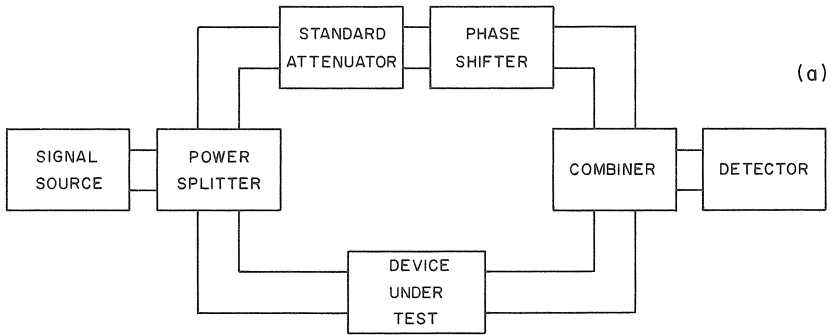

(a)

(b)

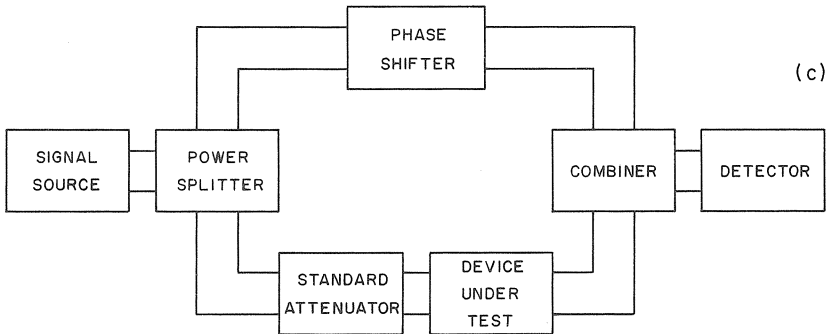
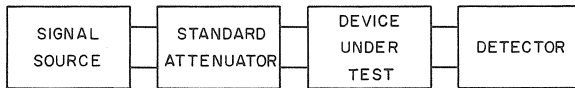

(c)

FIGURE 13. Basic arrangements for the measurement of attenuation using direct substitution.

- (a) Parallel
- (b) Series
- (c) Combination

The parallel substitution arrangement is well suited to use with waveguide-below-cutoff attenuators which have a high residual attenuation and very little change of phase shift.

The series substitution arrangement is often used when an attenuator is calibrated with reference to a standard attenuator built into a standard signal generator. It is also used to extend the range of IF substitution systems. It is very convenient and requires no phase shifters. However, it introduces additional loss between the signal source and the detector. For this reason, it is well-suited for use with the rotary vane attenuator which has small residual attenuation.

The combination arrangement [18k] has also been used for a wide range, high-precision, fixed-frequency system.

In addition to the waveguide-below-cutoff and the rotary vane types of attenuators, other attenuation standards have been used with direct substitution systems. For example, a short-circuited slotted line ideally has a sinusoidal voltage standing wave. One can then vary the output of the traveling probe in a predictable manner and calculate the relative output from the measured probe displacement relative to a minimum position. An arrangement for doing this is shown in figure 14(a). As one approaches a minimum, the probe response departs from the sinus-

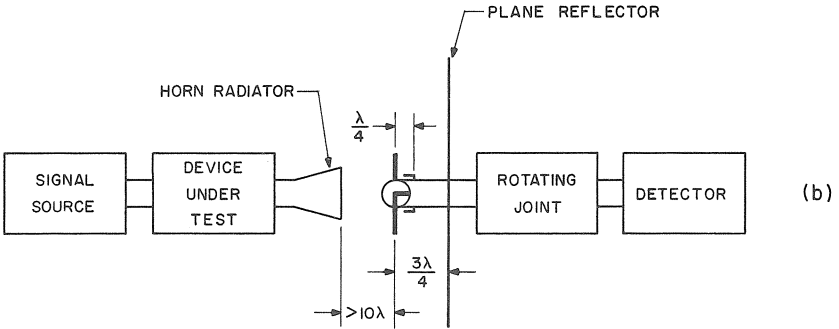
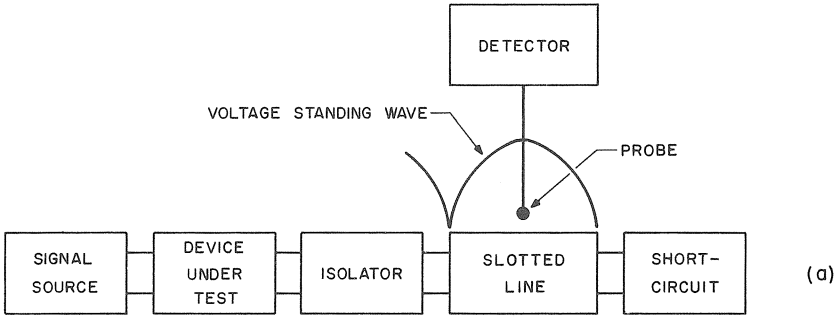

FIGURE 14. Standard attenuators for direct substitution attenuation measurements.

- (a) short-circuited slotted line
- (b) rotating dipole in plane polarized field

oidal distribution due to line losses. However, a practical range of 5 to 15 dB is possible. Near the maximum, the response is closest to sinusoidal. The variation of probe coupling with travel is within 0.5 percent or 0.04 dB in a slotted line of high quality.

Another standard of attenuation for direct substitution consists of a rotating dipole antenna in a linearly polarized field, as shown in figure 14(b). The probe response is ideally proportional to the cosine of the angle θ between the dipole and the E -field. Hence, relative levels can be predicted given the angular position of the dipole relative to the E -field.

5.7. Short-Circuited Attenuator [46]

The wave traveling through an attenuator and reflected by a short-circuit is attenuated twice before it reaches the input and becomes the reflected wave. Thus the reflection coefficient Γ at the input to a short-circuited attenuator should have a magnitude

$$|\Gamma| = e^{-2\alpha},$$

where α is the attenuation in nepers. (If A is the attenuation in decibels, $A = 8.686\alpha$.) Thus a short-circuited 20 dB pad should have an input reflection coefficient of 0.01, or a VSWR of 1.02. This assumes that the attenuator introduces no additional reflections. If this were generally true, it would be possible to determine the attenuation by measuring the VSWR of a short-circuited pad.

Unfortunately, attenuators usually produce internal reflections which are large enough to cause serious errors if the above procedure were followed. However, it is still possible to determine attenuation in terms of the input reflection coefficients of a short-circuited pad, the short-circuit being a sliding short-circuit in a section of waveguide.

Using a two-port network as a model for the attenuator, and assuming that $Z_{01} = Z_{02}$ it is known that the attenuation A is

$$A = 10 \log_{10} \frac{1}{|S_{21}|^2} = 10 \log_{10} \frac{1 - |S_{11}|^2}{|S_{21}|^2} + 10 \log_{10} \frac{1}{1 - |S_{11}|^2}, \quad (22)$$

where the two components are those due to dissipation and to reflection of energy, respectively, and it is assumed that energy enters port 1 and leaves port 2.

It is also known that the reflection coefficient Γ_2 is

$$\Gamma_2 = S_{22} + \frac{S_{12}S_{21}\Gamma_L}{1 - S_{11}\Gamma_L}, \quad (23)$$

where Γ_L is the reflection coefficient of a load terminating port 1, and the signal source is connected to arm 2.

If the phase of Γ_L is varied, while $|\Gamma_L|$ remains constant, the locus of Γ_2 is a circle of radius

$$R_2 = \frac{|S_{12}S_{21}\Gamma_L|}{1 - |S_{11}\Gamma_L|^2}. \quad (24)$$

Note that if $|\Gamma_L| = 1$ and $S_{12} = S_{21}$, then eq (24) gives the component of attenuation due to dissipation of energy. The component of attenuation due to reflection is calculated from eq (22). $|S_{11}|$ can be determined by measuring the input VSWR with port 2 terminated in a nonreflecting load.

Although this technique is interesting, it has limited applications. It is tedious to obtain the required data, since both magnitude and phase of reflection coefficient must be determined, and enough points obtained to determine a circle. Fair accuracy is possible with ordinary slotted line techniques over the range 0.5 to 25 dB. As the attenuation increases, the reflection coefficient circle gets smaller, and finally becomes indeterminate due to errors in the individual points.

A somewhat similar but more general technique [47] permits the determination of the attenuations of nonreciprocal or active devices. But again, this has limited application, and is usually accomplished better by other methods previously described.

5.8. Methods not Requiring Attenuation Standards [48]

Since the measurement of attenuation is basically the determination of a dimensionless ratio, a standard is not actually required. Although methods which do not require an attenuation standard may be relatively awkward or tedious, they are valuable in the event that a standard is not available. They may also be used to independently check an attenuation standard.

A number of methods have been developed in which known signal ratios are obtained by "power division," adding, and subtracting of signals. Two similar methods were independently developed and described at approximately the same time by Allred [48a] and Laverick [48b]. In order to illustrate these techniques, the method of Laverick will be briefly described.

As shown in figure 15, a three-channel system is employed in which the signal in the upper arm can be combined with either or both of the signals from the lower arms. The latter two signals can be switched in and out at will. Phase shifters and level set attenuators are provided so that a detector null can be obtained.

The procedure follows the sequence of operations shown in table 4.

(1) With the unknown attenuator X set to the maximum setting to be calibrated and arms P and Q open, the signal from the upper arm is adjusted to have a convenient amplitude α . (This is usually a small amplitude, but well above noise level in the detector.)

(2) This signal is combined with that from the central arm Q which is then adjusted so as to produce a detector null. The signal from arm Q then has an amplitude of $-\alpha$.

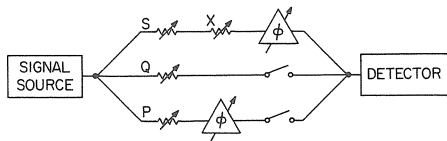

FIGURE 15. A three-channel arrangement for measuring ratios by sequential nulling techniques, thus permitting measurement of attenuation without reference to any standard attenuator.

TABLE 4. Signal amplitudes in each channel in successive operations in Laverick's procedure for calibrating an attenuator

Channel	Step 1					Step 2			Step 3			Etc.
	1	2	3	4	5	1	2	3	1	2	3	
<i>S</i>	α	α	α	α	2α	2α	2α	3α	3α	3α	4α	Etc.
<i>P</i>	-	-	$-\alpha$	$-\alpha$	$-\alpha$	-2α	-2α	-2α	-3α	-3α	-3α	
<i>Q</i>	-	$-\alpha$	-	$-\alpha$	$-\alpha$	-	$-\alpha$	$-\alpha$	-	$-\alpha$	$-\alpha$	

(3) With arm *Q* open, the signal from arm *S* is combined with that from the lower arm *P*. Arm *P* is then adjusted so as to produce a detector null. The signal from arm *P* then has an amplitude of $-\alpha$.

(4) The signals from all three channels are then combined.

(5) The attenuator *X* to be calibrated in arm *S* is adjusted for a detector null. (Some adjustment of the phase shifter in arm *S* may also be required, but it is assumed that this causes negligible change in the signal amplitude.)

This completes step 1.

It is clear that the attenuator adjustment changed the amplitude of the signal of arm *S* from α to 2α , and thus produced an attenuation change of 6.02 dB. In the subsequent steps, as shown in table 4, channel *Q* is not adjusted, but channel *P* is adjusted each time to balance channel *S*. Then, all three channels are combined so that the attenuator *X* must be changed a known amount to restore the detector null. The corresponding attenuation steps are 6.0206, 3.5218, 2.4988 dB, etc., as shown in table 5. The attenuator under test must be initially set at a fairly large dial reading, say 20 dB, since each step in the above procedure reduces its attenuation by a certain amount. Intermediate points can then be obtained by starting over again with a different initial setting of the test attenuator.

It is apparent that even though no attenuation standard is used, there are a number of sources of error present. For example, there are mis-

TABLE 5. Magnitude of amplitude ratio expressed in decibels for successive steps in the calibration of an attenuator by Laverick's procedure

Step	Magnitude of ratio of amplitude change in channel <i>S</i>	Incremental attenuation change in decibels	Total attenuation change in decibels
1	2	6.0206	6.0206
2	3/2	3.5218	9.5424
3	4/3	2.4988	12.0412
4	5/4	1.9382	13.9794
5	6/5	1.5836	15.5630
6	7/6	1.3390	16.9020
7	8/7	1.1598	18.0618
8	9/8	1.0230	19.0848
9	10/9	0.9152	20.0000
10	11/10	0.8278	20.8278

match errors caused by system reflections at the place where the test attenuator is inserted, changes in power division between channels caused by changes in reflection, changes in level caused by readjustments of phase shifters, and changes in level caused by frequency drift. There is also a small error each time that the signal in any channel is adjusted to produce a detector null, due to the limited resolution of this process. This error depends upon the sensitivity of the detector, repeatabilities of the attenuators, and noise level, and has a cumulative effect as more and more steps are taken. The procedure is not as convenient to use as methods which employ standard attenuators. However, if no standard is available, the method can be used, and with care, uncertainties of less than 0.02 dB in measurements of up to 20 dB can be achieved.

This method is well-suited for the calibration of variable attenuators which do not produce large changes in phase shift. Laverick has used the method for the calibration of rotary vane attenuators in rectangular waveguide, and Allred has calibrated waveguide-below-cutoff attenuators in coaxial systems. When such an attenuator is used as a standard in an intermediate frequency substitution method for attenuation measurement, confidence in the standard may be increased by calibrating it as Allred has done. In addition, he has shown how a measurement of the phase shift of the attenuator may also be made.

Several other methods not requiring a standard attenuator have been described by Peck [48c] and Davies [48d]. One of the methods [48c] makes use of a detector whose response varies linearly with the magnitude of the signal amplitude (a linear voltmeter, for example). A graphical method is used to eliminate the constants in the linear relationship, and the accuracy of the results is limited by the linearity of the detector and the precision of the graphical analysis.

This method is modified by using two- and three-channel nulling arrangements in which the dependence on detector linearity is eliminated, and the detector serves only as a null indicator. An interesting test of these methods was described by Peck. A waveguide-below-cutoff attenuation standard was "calibrated" by several methods and the results compared with the attenuation rate of 10.000 ± 0.002 dB per inch predicted from design data. Using three versions of his method, the following results were obtained: 10.006, 10.003, and 10.023 dB per inch. The discrepancy of approximately 0.02 dB per inch was ascribed to reflection interactions in the system.

The method described by Davies [48d] makes use of two identical 3-dB directional couplers and employs a two-channel circuit, nulling the demodulated outputs. Thus adjustable phase shifters are not required. The accuracy is claimed to be 1 percent of the attenuation in decibels, in contrast to Laverick's estimate of 0.1 percent.

5.9. Measurement of Small Attenuation

The measurement of small attenuation is of interest in the determination of losses in short sections of waveguide, and other low-loss components.

A number of methods are based upon the measurement of the VSWR of a short-circuited section of waveguide [49a, b].

Another method [49c] measures the loss of a transmission cavity constructed of the waveguide sample and two irises. The loss of each of the irises must be evaluated. Although not claimed to be highly accurate, the method is very convenient to use. The low loss is measured with reference to a rotary vane attenuator.

Methods having high resolution have been developed using a two-channel arrangement with nulling of audio or d-c signals after detection [49d, e]. They are inexpensive and convenient to use.

Another method having high resolution and accuracy uses a two-channel arrangement in which a null is obtained with a phase shifter and attenuator [49f]. Errors are reduced by use of a quarter-wavelength short-circuit and the selection of a frequency at which the length of the sample is effectively a half wavelength. Then no change in the phase shifter is required to restore the null. A rotary vane attenuator is used as a standard and a precision of 0.001 dB is obtained.

Direct substitution techniques are also used, but require exceptionally high stability of the signal source and detector.

6. Conclusions

Many methods are available to measure attenuation. The current state of the art can be inferred from articles in the literature [50]. It can be measured without reference to an attenuation standard. However, methods which employ an attenuation standard are more convenient to use.

At present, the claim of highest accuracy is ± 0.0001 dB at 0.01 dB, using d-c substitution techniques. At 30 MHz, a range of 150 dB is obtained in a series-parallel substitution arrangement using a waveguide-below-cutoff attenuator of high accuracy. Somewhat greater ranges are obtainable from signal generators, but accuracy is ± 2 dB.

The rotary vane attenuator shows promise as a standard attenuator. However, refinements and the analysis of errors are currently underway. The rotary vane attenuator will probably be used as a standard of attenuation in IF substitution systems operating at 0.1 to 10 THz. At higher frequencies, prisms, polarizers-analyzers, and other optical techniques will probably take over.

The above material has evolved as a result of two courses presented at NBS over the past several years. One was entitled Microwave Measurements and the other was the RSL Summer Course in Electromagnetic Measurements. The author has consulted notes prepared for these courses by C. M. Allred and G. E. Schafer of NBS, as well as textbook material by numerous other authors [51]. In addition, considerable information arising out of the author's own experience is presented. Helpful discussions on attenuation measurements and standards have been held with a number of NBS personnel, including D. A. Ellerbruch, W. Larson, W. E. Little, A. Y. Rumfelt, and D. H. Russell. The very thorough review of this manuscript by C. C. Cook was especially valuable. References to work published in the literature may not actually be complete but are fairly extensive.

7. References

- * [1] IRE standards on antennas and waveguides: Definitions of terms, Proc. IRE **41**, No. 12, 1721-1728; Standard 53-IRE 2.S1, 1953.
- [2] R. W. Beatty, Insertion loss concepts, Proc. IEEE **52**, 663-671 (June 1964).
- [3] R. W. Beatty, The system of electromagnetic quantities at frequencies above 1 GHz, Metrologia **2**, 46-54 (Jan. 1966).
- [4] I. A. Harris, Mode of use and assessment of precision coaxial connectors, Proc. IEE (London) **112**, 2025-2032 (Nov. 1965).
- [5] By adapting eq (2.50) of Basic Theory of Waveguide Junctions and Introductory Microwave Network Analysis, David M. Kerns and Robert W. Beatty, Pergamon Press, New York, N.Y., May 1967, one can write

$$iP_L = \frac{|b_G|^2}{Z_{02}} \cdot \frac{|iS_{21}|^2(1 - |\Gamma_L|^2)}{|(1 - iS_{11}i\Gamma_G)(1 - iS_{22}i\Gamma_L) - iS_{12}iS_{21}i\Gamma_Gi\Gamma_L|^2}$$

It follows that the ratio of iP_L to jP_L is

$$\frac{iP_L}{jP_L} = \frac{|b_G|^2}{|b_G|^2} \cdot \frac{|iS_{21}|^2}{|jS_{21}|^2} \cdot \frac{1 - |\Gamma_L|^2}{1 - |j\Gamma_L|^2} \cdot \frac{|(1 - jS_{11}i\Gamma_G)(1 - jS_{22}i\Gamma_L) - jS_{12}iS_{21}i\Gamma_Gi\Gamma_L|^2}{|(1 - iS_{11}i\Gamma_G)(1 - iS_{22}i\Gamma_L) - iS_{12}iS_{21}i\Gamma_Gi\Gamma_L|^2}$$

and eq (3) then follows from substitution of the ratio of iP_L to jP_L into eq (1).

- [6] See for example Ernst Weber, The measurement of attenuation, in Technique of Microwave Measurements, Sect. 13.5, Ch. 13, MIT Rad. Lab. Series **11**, McGraw-Hill Book Co., Inc., New York, N.Y., 824-832 (1947).
- [7] R. W. Beatty, Effects of connectors and adapters on accurate attenuation measurements at microwave frequencies, IEEE Trans. Instr. **13**, 272-284 (Dec. 1964).
- [8] R. W. Beatty, Mismatch errors in the measurement of ultrahigh-frequency and microwave variable attenuators, J. Res. NBS **52**, 7-9 (Jan. 1954).
- [9] G. E. Schafer and A. Y. Rumpf, Mismatch errors in cascade-connected variable attenuators, IRE Trans. MTT **7**, 447-453 (Oct. 1959).
- [10] K. Tomiyasu, Intrinsic insertion loss of a mismatched microwave network, IRE Trans. MTT **3**, 40-44 (Jan. 1955).
- [11] R. W. Beatty, Intrinsic attenuation, IEEE Trans. MTT **11**, 179-182 (May 1963).
- [12] H. M. Altschuler and W. K. Kahn, Nonreciprocal two-ports represented by modified Wheeler networks, IRE Trans. MTT **4**, 228-233 (Oct. 1956).
- [13] Andrew F. Dunn, Calibration of a Kelvin-Varley voltage divider, IEEE Trans. Instr. Meas. **13**, 129-139 (June-Sept. 1964).
- [14] Walter J. Karplus, Design and error analysis of high-accuracy DC voltage-measuring systems, IEEE Trans. Instr. Meas. **13**, 139-145 (June-Sept. 1964).
- [15] Thomas L. Zapf, Voltage ratio measurements with a transformer capacitance bridge, J. Res. NBS **66C**, 25-32 (Jan.-Mar. 1962).
- [16] T. L. Zapf, The accurate measurement of voltage ratios of inductive voltage dividers, Acta IMEKO **III**, 317-331 (1964).
- [17] J. S. Elliott, Coaxial attenuation standards, Bell Labs. Record **27**, 221-225 (June 1949).
- [18] Selected bibliography on waveguide-below-cutoff attenuators:
- a. D. E. Harnett and N. P. Case, The design and testing of multirange receivers, Proc. IRE **23**, 578-593 (June 1935).
 - b. R. N. Griesheimer, Microwave attenuators. Cutoff attenuators, Technique of microwave measurements, Ch. 11, MIT Rad. Lab. Series, **11**, McGraw-Hill Book Co., Inc., New York, N.Y., 685-719 (1947).
 - c. G. F. Gainsborough, A method of calibrating standard-signal generators and radio-frequency attenuators, J. IEEE (London) **94**, Pt. III, 203-210 (May 1947).
 - d. J. J. Freeman, Theory and design of a cavity attenuator, J. Res. NBS **40**, 235-243 (Mar. 1948).
 - e. R. E. Grantham and J. J. Freeman, A standard of attenuation for microwave measurements, Trans. AIEE **67**, 329-335 (June 1948).
 - f. H. A. Wheeler, The piston attenuator in a waveguide below cutoff, Wheeler Mono. No. 8 (Jan. 1949).
 - g. J. Brown, Corrections to the attenuation constants of piston attenuators, Proc. IEE (London) **96**, Pt. III, 491-495 (Nov. 1949).
 - h. H. M. Barlow and A. L. Cullen, Microwave measurements, Constable and Co., Ltd., London, England, 242-254, 384-388 (1950).

- i. C.M. Allred, Chart for the TE₁₁ mode piston attenuator, J. Res. NBS **48**, 109–110 (Feb. 1952).
- j. D. M. Kerns and R. W. Hedberg, Propagation constant in rectangular waveguide of finite conductivity, J. Appl. Phys. **25**, 1550–1551 (Dec. 1954).
- k. C. M. Allred and C. C. Cook, A precision RF attenuation calibration system, IRE Trans. Instr. **9**, 268–274 (Sept. 1960).
- l. L. A. Birger, Nonlinearity of cutoff attenuators due to the effect of loading, Izv. Tekh. No. 11, 59–61 (1960).
- m. D. L. Hollway and F. P. Kelly, A standard attenuator and the precise measurement of attenuation, IEE Trans. Instr. Meas. **13**, 33–44 (Mar. 1964).
- n. B. O. Weinschel and G. U. Sorger, Waveguide below cutoff attenuation standard, Acta IMEKO **III**, 407–424 (1964).
- [19] Selected bibliography on the rotary vane attenuator:
 - a. G. C. Southworth, Principles and Applications of Waveguide Transmission, D. Van Nostrand Co., Inc., New York, N.Y. 374–376 (1950).
 - b. B. P. Hand, A precision waveguide attenuator which obeys a mathematical law, Hewlett-Packard Journal **6**, 1–2 (Jan. 1955).
 - c. Wilbur Larson, Analysis of rotation errors of a waveguide rotary vane attenuator, IRE International Convention Record, Pt. 3, 213–219 (1962).
 - d. P. F. Mariner, An absolute microwave attenuator, Proc. IEE (London) **109**, Pt. B, 415–419 (Sept. 1962).
 - e. Allan V. James, A high-accuracy microwave-attenuation standard for use in primary calibration laboratories, IRE Trans. Instr. **11**, 285–290 (Dec. 1962).
 - f. Wilbur Larson, Table of attenuation error as a function of vane-angle error for rotary vane attenuators, NBS Tech. Note No. 177 (May 1963).
 - g. Wilbur Larson, Gearing errors as related to alignment techniques of the rotary vane attenuator, IEEE Trans. Instr. Meas. **14**, 117–123 (Sept. 1965).
 - h. Wilbur Larson, Table of attenuation as a function of vane angle for rotary-vane attenuators ($A = -40 \log_{10} \cos \theta$), NBS Tech. Note No. 229 (Jan. 7, 1965).
- [20] G. F. Engen and R. W. Beatty, Microwave attenuation measurements with accuracies from 0.0001 to 0.06 decibel over a range of 0.01 to 50 decibels, J. Res. NBS **64C**, 139–145 (Apr.–June 1960).
- [21] R. W. Beatty and C. E. Huber, Lossy cable attenuator pads, Rev. Sci. Instr. **24**, 1002–1003 (Oct. 1953).
- [22] B. O. Weinschel, Card attenuator for microwave frequencies, U.S. Patent No. 3,157,846 (17 Nov. 1964).
- [23] Wilbur Larson, Inline waveguide attenuator (correspondence), IEEE Trans. MTT **12**, 367–368 (May 1964).
- [24] B. O. Weinschel, An accurate attenuation measuring system with great dynamic range, Microwave J. **4**, 77–83 (Sept. 1961).
- [25] Glenn F. Engen, Recent developments in the field of microwave power measurements at the National Bureau of Standards, IRE Trans. Instr. **7**, 304–306 (Dec. 1958).
- [26] John Korewick, A-M System measures microwave attenuation, Electronics **27**, 175–177 (Jan. 1954).
- [27] G. U. Sorger and B. O. Weinschel, Comparison of deviations from square law for RF crystal diodes and barretters, IRE Trans. Instr. **8**, 103–111 (Dec. 1959).
- [28] G. F. Engen, A DC-RF substitution error in dual-element bolometer mounts, IEEE Trans. Instr. Meas. **13**, 58–64 (June–Sept. 1964). (It is noted that the substitution error varies with power level.)
- [29] Square-law microwave detector, Military Sys. Design **6**, 58 (Sept.–Oct. 1962).
- [30] G. B. Bogdanov, Possible application of ferrites for absolute measurement of microwave power (Radiotekhnika i Elektronika, **4**, 663 (1961)). Radio Engineering and Electronic Physics **4**, 587 (1961).
- [31] F. L. Wentworth, J. D. Rodgers, J. W. Dozier, and M. Cohn, Millimeter wave harmonic generators, mixers, and detector, Program and Digest, The Millimeter and Submillimeter Conference. (Copies available from E. D. Houseman, MP-75, Martin Co., Orlando, Florida) 103–105 (1963).
- [32] S. Hopfer, N. H. Riederman, and L. Nadler, The properties of thermoelectric elements as microwave power detectors, IRE Intern. Convention Record, Pt. 3, 77–84 (1962).
- [33] G. U. Sorger and B. O. Weinschel, Precise insertion loss measurements using imperfect square law detectors and accuracy limitations due to noise, IRE Trans. Instr. **4**, 55–68 (Oct. 1955).
- [34] The Microwave Engineer's Handbook and Buyer's Guide, 318–319 (1966).
- [35] R. W. Beatty, Cascade-connected attenuators, J. Res. NBS **45**, 231–235 (Sept. 1950).
- [36] A. N. Leber, Method free from mismatching errors for measuring the loss of attenuators (Correspondence), IEEE Trans. MTT **12**, 480 (July 1964).

- [37] F. E. Terman, *Radio Engineering*, McGraw-Hill Book Co., Inc., New York, N.Y., 2d ed., 448–449 (1937).
- [38] B. O. Weinschel, G. U. Sorger, and A. L. Hedrich, Relative voltmeter for VHF/UHF signal generator attenuator calibration *IRE Trans. Instr.* **8**, 22–31 (Mar. 1959).
- [39] E. Niesen, R. W. Beatty, and W. J. Anson, Water-cooling of low-power klystrons used in the laboratory, *Rev. Sci. Instr.* **29**, 791–792 (Sept. 1958).
- [40] Wilbur Anson and Edward Niesen, Fast melting alloy forms water jacket for small klystrons, *Micro Waves* **42** (Mar. 15, 1962).
- [41] A good discussion is given on pp. 830–831 of reference 6.
- [42] See pp. 845–846 of reference 6.
- [43] Comparison of two techniques for measuring microwave attenuation. *NBS Tech. News Bull.* **44**, 192–193 (Nov. 1960).
- [44] G. E. Schafer and R. R. Bowman, A modulated sub-carrier technique of measuring microwave attenuation, *Proc. IEE (London)* **109**, Pt. B, Suppl. No. 23, 783–786 (May 1962).
- [45] William E. Little, Further analysis of the modulated subcarrier technique of attenuation measurement, *IEEE Trans. Instr. Meas.* **13**, 71–76 (June–Sept. 1964).
- [46] R. W. Beatty, Determination of attenuation from impedance measurements, *Proc. IRE* **38**, 895–897 (Aug. 1950).
- [47] H. M. Altschuler, The measurement of arbitrary linear microwave two-ports, *Proc. IEE (London)* **109**, Pt. B, Suppl. No. 23, 704–712 (May 1962).
- [48] Selected bibliography on measurement of attenuation without using a standard:
- Self-calibrating method of measuring insertion ratio, *NBS Tech. News Bull.* **41**, 132–133 (Sept. 1957).
 - E. Laverick, The calibration of microwave attenuators by an absolute method, *IRE Trans. MTT* **4**, 250–254 (Oct. 1957).
 - R. L. Peck, A method for the self-calibration of attenuation-measuring systems, *J. Res. NBS* **66C**, 13–18 (Jan.–Mar. 1962).
 - M. C. Davies, An absolute method for calibrating microwave attenuators, *Proc. IEE (London)* **109**, Pt. B, Suppl. No. 23, 796–800 (May 1962).
- [49] Selected bibliography on the measurement of small attenuations:
- W. T. Blackband and D. R. Brown, The two-point method of measuring characteristic impedance and attenuation of cables at 3000 Mc/s, *J. IEE*, Pt. IIIA, **93**, 1383–1386 (1946).
 - J. H. Vogelman, Precision measurement of waveguide attenuation, *Electronics* **26**, 196–199 (Dec. 1953).
 - Peter D. Lacy and Kenneth E. Miller, An improved method for measuring losses in short waveguide lengths, *Hewlett-Packard J.* **9** (Nov.–Dec. 1957).
 - B. O. Weinschel, Insertion loss test sets using square law detectors, *IRE Trans. Instr.* **4**, 160–164 (Oct. 1955).
 - C. T. Stelzried and S. M. Petty, Microwave insertion loss test set (correspondence), *IEEE Trans. MTT* **12**, 475–477 (July 1964).
 - R. W. Beatty, A two-channel nulling method for measuring attenuation constants of short sections of waveguide and the losses in waveguide joints (correspondence), *Proc. IEEE* **53**, 642–643 (June 1965).
- [50] The current state of the art in attenuation standards can be inferred from manufacturer's literature and from articles in the literature such as the following:
- R. E. Larson, Microwave measurements in the NBS electronic calibration center, *Proc. IEE (London)* **109**, Pt. B, Suppl. No. 23, 644–650 (May 1962).
 - R. W. Beatty, Standards and measurements of attenuation, impedance, and phase shift, September 1960–December 1962 (URSI USA National Committee Report, XIVth General Assembly, 1963), *Radio Science J. Res. NBS/USNC-URSI* **68D**, 529–533 (May 1964).
 - R. W. Beatty, Microwave standards and measurements, A progress review 1960–1963, *IEEE Trans. Instr. Meas.* **12**, 134–138 (Dec. 1963). Also see the book *Progress in Radio Science, 1960–1963, Vol. I. Radio Standards and Measurements*, Elsevier Publ. Co., Amsterdam, 1965. Articles in this book by D. Woods, S. Okamura and K. Sakurai, D. L. Holloway, and others discuss attenuation measurements.
 - Engineering Division, Radio Standards Laboratory, National Bureau of Standards, Microwave and high-frequency calibration services of the National Bureau of Standards, part II (correspondence), *IEEE Trans. MTT* **12**, 572–576 (Sept. 1964).
 - W. A. Wildhack, R. C. Powell, and H. L. Mason (editors), *Accuracy in measurements and calibrations*, 1965, *NBS Tech. Note* 262 (June 15, 1965).
 - J. E. Ebert and G. U. Sorger, Survey of precision microwave attenuation measuring techniques, *ISA Trans.* **3**, 280–290 (July 1964).

[51] The following textbooks contain valuable source material on microwave attenuation measurements and standards.

- a. C. G. Montgomery (editor), *Technique of Microwave Measurements*, MIT Rad. Lab. Series 11, McGraw-Hill Book Co., Inc., New York, N.Y., 1947. (See part IV, beginning on p. 679.)
- b. Donald D. King, *Measurements at Centimeter Wavelength*, D. Van Nostrand Co., Inc., New York, N.Y., 1952. (See sect. 3.13 beginning on p. 99.)
- c. E. L. Ginzton, *Microwave Measurements*, McGraw-Hill Book Co., Inc., New York, N.Y., 1957. (See ch. 11, beginning on p. 462.)
- d. Sucher & Fox (editors), *Handbook of Microwave Measurements*, 3d ed., Polytechnic Press, Polytechnic Institute of Brooklyn, Brooklyn, N.Y., 1963. (See ch. VII, beginning in vol. I, p. 377.)

U. S. GOVERNMENT PRINTING OFFICE : 1967 OL-229-293



U.S. DEPARTMENT OF COMMERCE
WASHINGTON, D.C. 20230

POSTAGE AND FEES PAID
U.S. DEPARTMENT OF COMMERCE

OFFICIAL BUSINESS
