

Nuclear Waste Policy Act
(Section 113)

DOE/RW--0160-Vol.5
DE88 007746

Consultation Draft

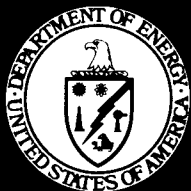

Site Characterization Plan

***Yucca Mountain Site, Nevada Research
and Development Area, Nevada***

Volume V

January 1988

U.S. Department of Energy
Office of Civilian Radioactive Waste Management
Washington, DC 20585

Prepared Under Contract No. DE-AC08-87NV 10576

MASTER

EB

DISCLAIMER

This report was prepared as an account of work sponsored by an agency of the United States Government. Neither the United States Government nor any agency thereof, nor any of their employees, make any warranty, express or implied, or assumes any legal liability or responsibility for the accuracy, completeness, or usefulness of any information, apparatus, product, or process disclosed, or represents that its use would not infringe privately owned rights. Reference herein to any specific commercial product, process, or service by trade name, trademark, manufacturer, or otherwise does not necessarily constitute or imply its endorsement, recommendation, or favoring by the United States Government or any agency thereof. The views and opinions of authors expressed herein do not necessarily state or reflect those of the United States Government or any agency thereof.

DISCLAIMER

Portions of this document may be illegible in electronic image products. Images are produced from the best available original document.

CONSULTATION DRAFT

DOCUMENT ORGANIZATION

Introduction

Part A: Description of the mined geologic disposal system

Introduction

Chapter 1--Geology

Chapter 2--Geoengineering

Chapter 3--Hydrology

Chapter 4--Geochemistry

Chapter 5--Climatology and meteorology

Chapter 6--Conceptual design of a repository

Chapter 7--Waste package

Part B: Site characterization program (Chapter 8)

8.0 Introduction

8.1 Rationale

8.2 Issues

8.3 Planned tests, analyses, and studies

8.3.1 Site program

8.3.1.1 Site overview

8.3.1.2 Geohydrology

8.3.1.3 Geochemistry

8.3.1.4 Rock characteristics

8.3.1.5 Climate

8.3.1.6 Erosion

8.3.1.7 Rock dissolution

8.3.1.8 Postclosure tectonics

8.3.1.9 Human interference

8.3.1.10 Population density and distribution

8.3.1.11 Land ownership and mineral rights

8.3.1.12 Meteorology

8.3.1.13 Offsite installations

8.3.1.14 Surface characteristics

8.3.1.15 Thermal and mechanical properties

8.3.1.16 Preclosure hydrology

8.3.1.17 Preclosure tectonics

8.3.2 Repository program

8.3.2.1 Repository overview

8.3.2.2 Configuration of underground facilities (postclosure)

8.3.2.3 Repository design criteria for radiological safety

8.3.2.4 Nonradiological health and safety

8.3.2.5 Preclosure design and technical feasibility

8.3.3 Seal program

8.3.3.1 Seal overview

8.3.3.2 Seal characteristics

CONSULTATION DRAFT

DOCUMENT ORGANIZATION (continued)

- 8.3.4 Waste package
 - 8.3.4.1 Waste package overview
 - 8.3.4.2 Waste package characteristics (postclosure)
 - 8.3.4.3 Waste package characteristics (preclosure)
 - 8.3.4.4 Waste package production technologies
- 8.3.5 Performance assessment program
 - 8.3.5.1 Strategy for preclosure performance assessment
 - 8.3.5.2 Waste retrievability
 - 8.3.5.3 Public radiological exposures--normal conditions
 - 8.3.5.4 Worker radiological safety--normal conditions
 - 8.3.5.5 Accidental radiological releases
 - 8.3.5.6 Higher-level findings--preclosure radiological safety
 - 8.3.5.7 Higher-level findings--ease and cost of construction
 - 8.3.5.8 Strategy for postclosure performance assessment
 - 8.3.5.9 Containment by waste package
 - 8.3.5.10 Engineered barrier system release rates
 - 8.3.5.11 Seal performance
 - 8.3.5.12 Ground-water travel time
 - 8.3.5.13 Total system performance
 - 8.3.5.14 Individual protection
 - 8.3.5.15 Ground-water protection
 - 8.3.5.16 Performance confirmation
 - 8.3.5.17 NRC siting criteria
 - 8.3.5.18 Higher level findings--postclosure system and technical guidelines
 - 8.3.5.19 Completed analytical techniques
 - 8.3.5.20 Analytical techniques requiring development
- 8.4 Planned site preparation activities
- 8.5 Milestones, decision points, and schedule
- 8.6 Quality assurance program
- 8.7 Decontamination and decommissioning

Glossary and acronyms

Nuclear Waste Policy Act
(Section 113)

Section 8.3.14

Consultation Draft

ROCK CHARACTERISTICS



Site Characterization Plan

***Yucca Mountain Site, Nevada Research
and Development Area, Nevada***

Volume V

January 1988

U.S. Department of Energy
Office of Civilian Radioactive Waste Management
Washington, DC 20585

CONSULTATION DRAFT

8.3.1.4 Overview of the rock characteristics program: Description of the present and expected rock characteristics required by performance and design issues

Summary of performance and design requirements for rock characteristics information

Compliance with performance and design criteria for a geologic repository will require information about the rock characteristics of the Yucca Mountain site. This information will be used in the design of underground repository facilities and to support assessments of site performance related to ground-water travel time, waste-package lifetime, radionuclide releases from the engineered-barrier system (EBS), and radionuclide releases to the accessible environment. The various regulatory requirements are concerned with rock characteristics, conditions, and processes in different subsurface regions within and around Yucca Mountain.

The siting criteria discussed in 10 CFR 60.122 must also be evaluated, including the favorable condition for waste emplacement at a depth of 300 m and characterization of structural, stratigraphic, and geomechanical conditions to determine if potentially adverse conditions are present. Design criteria for the underground facility, seals of shafts and boreholes, and waste packages are also evaluated in the context of the natural rock properties of the site. Assessments of whether the performance objectives, siting criteria, and design criteria can be met will rely on information about the stratigraphy and structure of the Yucca Mountain site, the properties of the rock units occurring at the site, and the temperature and stress conditions before excavation of underground openings.

Approach to satisfy performance and design requirements

The geologic and geophysical site characterization activities described in this section provide an important category of information needed to develop a three-dimensional physical property model, i.e., the geometry associated with the material properties of the rock at the Yucca Mountain site. The objective of the three-dimensional model is to provide a computer-based representation of the physical properties of the rocks at the site. The data base for the model will contain the distribution of parameters (physical properties) within property-dependent units. An important function of the computer-based model will be to provide input for numerical computer analyses that involve hydrologic, thermal, thermomechanical, and geochemical processes.

The three-dimensional physical properties model is a representation of the Yucca Mountain repository site containing various kinds of data on its geologic, geohydrologic, thermal, mechanical, and geochemical properties. The model will allow predictions of how a physical property changes spatially within and across the boundaries of the model. The boundaries represent distinct changes in a property.

The location of the physical property boundaries will be based on three sources of information: (1) geologic studies, (2) geophysical studies, and (3) the physical property data. The physical properties model could be

CONSULTATION DRAFT

developed based entirely on the samples from site characterization. However, the geologic complexity of the Yucca Mountain site may cause large amounts of uncertainty associated with the variability of the properties between sample locations. Therefore, the geologic and geophysical data will be used to provide the geometric framework for the physical property data in the model. The nature and number of site characterization studies to be conducted will be determined by the level of confidence required for the physical properties and the numerical models in which they are being input.

Figure 8.3.1.4-1 provides the overall logic for developing the three-dimensional physical property model. The geologic, hydrologic, geochemical, and thermal/mechanical properties are the fundamental information to be contained in the model. The geologic framework serves as the geometric framework for the physical property model. The hydrologic, geochemical, and thermal mechanical properties will be developed in Sections 8.3.1.2, 8.3.1.3 and 8.3.1.15 respectively. These separate categories of properties are called on in this section in order to integrate them into the physical properties model. Table 8.3.1.4-1 serves as the first step in the correlation of parameter requests from design or performance issues (e.g., performance or design parameters in sections 8.3.5.12, 8.3.5.13, 8.3.2.2, and 8.3.3) and results from data gathering activities (activity parameters and associated characterization parameters). The parameter categories listed in Table 8.3.1.4-1 are topical categories that are used to translate data requests for types of design and performance information into similar types of site data to be collected. Because of the diversity and volume of data needs called for in the design and performance issues and data provided by characterization activities, it is inappropriate to expect a one-to-one correspondence between a requested performance parameter and an activity parameter. Rather, a given characterization parameter in almost every case will require data reduction and analysis of several related tests and data gathering activities to transform them into the information directly used in design or performance analysis.

Characterization parameters commonly will take the form of maps and other two- or three-dimensional illustrations, such as isopach maps, isopleth maps and structure contour maps, or diagrams displaying statistical distributions of activity parameters throughout the site. Many parameters will also include a spatial or unit-specific component such as an isopach map of a specific stratigraphic unit within a specified area. The eventual formulation of an appropriate testing basis for each characterization parameter will include the identification of (1) tentative parameter goals, (2) current estimate of parameter values, (3) current confidence level, and (4) needed confidence level. For example, if an isopach map of the thermomechanical unit TSw2 within the boundary of the repository perimeter drift is identified as a characterization parameter, then the tentative parameter goal may be that contours are accurate to within ± 30 m. Current estimates of the parameter will be obtained from information or references in Chapter 1 of the SCP. Needed confidence levels will indicate how important this information is to design and performance issues. Current levels of confidence will, in most cases, be low.

The grouping of performance parameters into categories is a necessary first step because individual parameter requests commonly differ with respect to such things as specific spatial locations, stratigraphic units, and

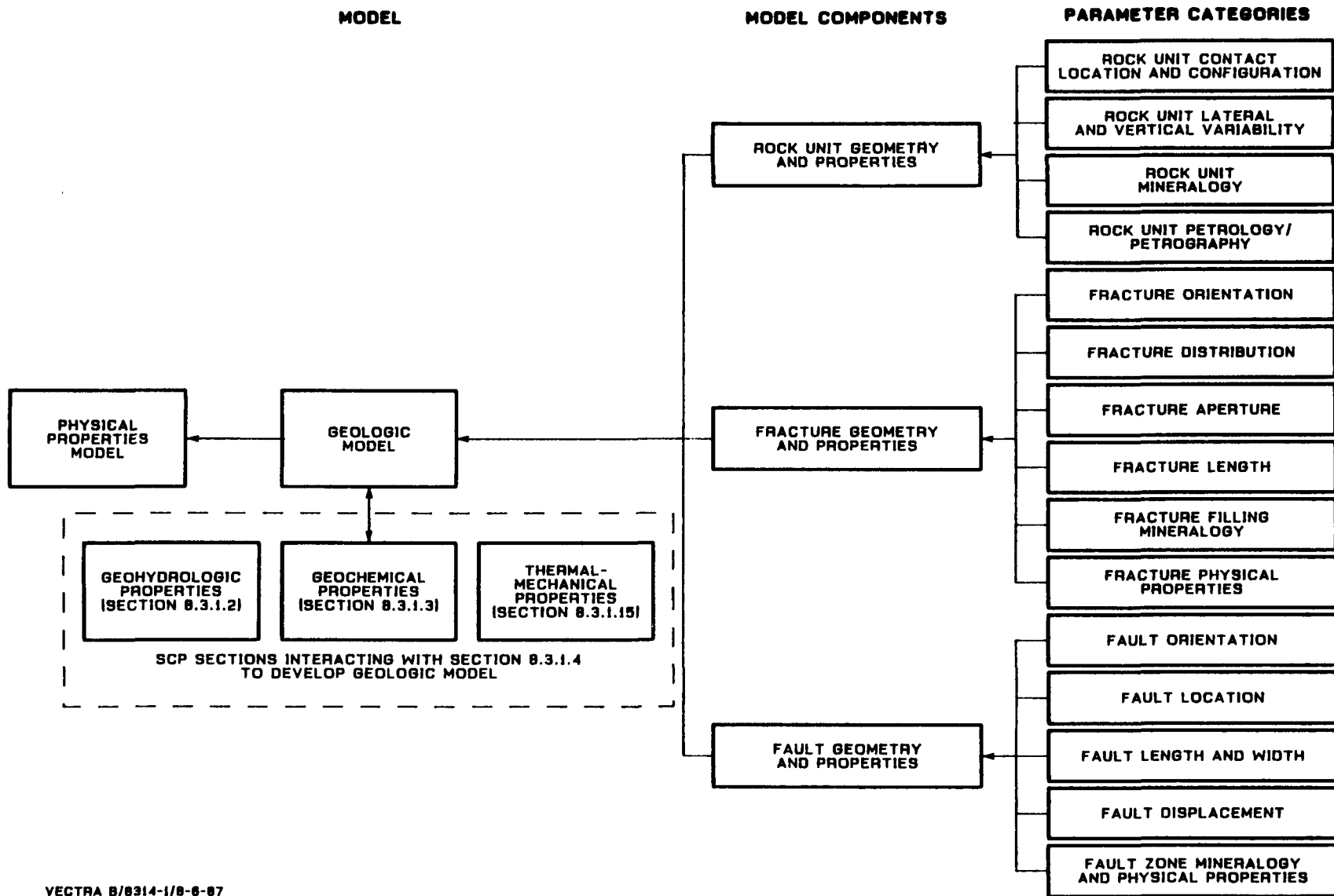

Figure 8.3.1.4-1. Logic diagram for the three-dimensional physical properties model.

Table 8.3.1.4-1. Activity parameters provided by the rock characteristics program that support performance and design issues (page 1 of 12)

Calls by performance and design issues		Parameter category	Response by rock characteristics program	
Issue	SCP section		Activity parameter	SCP activity
ROCK UNIT GEOMETRY AND PROPERTIES				
1.1	8.3.5.13	Rock-unit contact location and configuration	Attitude, ash-flow zones	8.3.1.4.2.2.1
1.6	8.3.5.12		Attitude, bedded-tuff zones	8.3.1.4.2.2.1
1.11	8.3.2.2		Attitude, lithostratigraphic units	8.3.1.4.2.1.1
1.12	8.3.3.2		Borehole diameter	8.3.1.4.2.1.3
4.4	8.3.2.5		Color, lithostratigraphic units	8.3.1.4.2.1.1
			Contacts, flow units	8.3.1.4.2.1.5
			Contacts, lithostratigraphic units, nature	8.3.1.4.2.1.1
			Correlatable sequences	8.3.1.4.2.1.1
			Depth, lithostratigraphic units	8.3.1.4.2.1.1
			Geophysical signature, lithostratigraphic markers	8.3.1.4.2.1.3
			Key marker beds	8.3.1.4.2.1.1
			Lateral continuity of horizons	8.3.1.4.2.1.2
			Lithology, stratigraphic sequence	8.3.1.4.2.2.4
			Locations, bedded tuff units	8.3.1.4.2.1.1
			Magnetic property changes, core samples	8.3.1.4.2.1.5
			Petrographic changes, core samples	8.3.1.4.2.1.4
		Seismic velocities	8.3.1.4.2.1.3	
		Spontaneous potential	8.3.1.4.2.1.3	
Stratigraphic sequence, Topopah Spring welded unit	8.3.1.4.2.2.4			
Stratigraphic sequence, lithostratigraphic units	8.3.1.4.2.1.1			
Thickness, flow units	8.3.1.4.2.1.5			
Thickness, lithostratigraphic units	8.3.1.4.2.1.1			

8.3.1.4-4

CONSULTATION DRAFT

Table 8.3.1.4-1. Activity parameters provided by the rock characteristics program that support performance and design issues (page 2 of 12)

Calls by performance and design issues		Parameter category	Response by rock characteristics program	
Issue	SCP section		Activity parameter	SCP activity
			Vertical distribution, lithostratigraphic units	8.3.1.4.2.1.2
1.1	8.3.5.13	Rock-unit lateral and vertical variability	Acoustic velocity, core samples	8.3.1.4.2.1.4
1.6	8.3.5.12		Age, potassium-argon, lithostratigraphic units	8.3.1.4.2.1.1
1.11	8.3.2.2		Areal extent, exposed bedrock	8.3.1.4.2.2.1
1.12	8.3.3.2		Density, bulk, in situ	8.3.1.4.2.1.3
4.4	8.3.2.5		Density, grain and bulk, core samples	8.3.1.4.2.1.4
			Density, variations	8.3.1.4.2.1.2
			Depositional characteristics, lithostratigraphic units	8.3.1.4.2.1.1
			Depositional units, Topopah Spring Member	8.3.1.4.2.1.5
			Electrical conductivity	8.3.1.4.2.1.3
			Electrical resistivity, core samples	8.3.1.4.2.1.4
		Electromagnetic properties, variations	8.3.1.4.2.1.2	
		Emplacement history, ash-flow tuffs	8.3.1.4.2.1.1	
		Extent, lithostratigraphic units	8.3.1.4.2.1.1	
		Gravitational field, variations	8.3.1.4.2.1.2	
		Hydraulic conductivity, core samples	8.3.1.4.2.1.4	
		Induced polarization, core samples	8.3.1.4.2.1.4	
		Laboratory/in situ rock property correlation, surface and subsurface geophysics	8.3.1.4.2.1.4	
		Lateral continuity, horizons	8.3.1.4.2.1.2	
		Lateral continuity, repository host horizon	8.3.1.4.2.2.4	

8.3.1.4-5

CONSULTATION DRAFT

Table 8.3.1.4-1. Activity parameters provided by the rock characteristics program that support performance and design issues (page 3 of 12)

Calls by performance and design issues		Parameter category	Response by rock characteristics program	
Issue	SCP section		Activity parameter	SCP activity
			Lateral extent, ash-flow zones	8.3.1.4.2.2.1
			Lateral extent, bedded-tuff zones	8.3.1.4.2.2.1
			Lateral variability, lithostratigraphic units, exploratory shaft facility drifts	8.3.1.4.2.2.4
			Lithic fragments, concentration variations, subunit contacts	8.3.1.4.2.1.5
			Lithic fragments, type and abundance, lithostratigraphic units	8.3.1.4.2.1.1
			Lithic-rich subzones, locations, flow units	8.3.1.4.2.1.5
			Lithologic uniformity, relations to density, seismic velocity, porosity, and resistivity	8.3.1.4.2.1.4
			Lithophysal zone characteristics, lithostratigraphic units	8.3.1.4.2.1.1
			Lithophysal zones, geophysical signatures	8.3.1.4.2.1.3
			Magnetic field intensity, total	8.3.1.4.2.1.2
			Magnetic field, variations	8.3.1.4.2.1.2
			Magnetic susceptibility	8.3.1.4.2.1.3
			Magnetic susceptibility	8.3.1.4.2.1.5
			Porosity, core samples	8.3.1.4.2.1.4
			Porosity, variations	8.3.1.4.2.1.3
			Pumice characteristics, lithostratigraphic units	8.3.1.4.2.1.1
			Pumice clasts, concentration variations, subunit contacts	8.3.1.4.2.1.5

8.3.1.4-6

CONSULTATION DRAFT

Table 8.3.1.4-1. Activity parameters provided by the rock characteristics program that support performance and design issues (page 4 of 12)

Calls by performance and design issues		Parameter category	Response by rock characteristics program	
Issue	SCP section		Activity parameter	SCP activity
			Pumice clasts, concentrations, flow units	8.3.1.4.2.1.5
			Rock characteristics, changes, Topopah Spring Member	8.3.1.4.2.1.5
			Seismic velocity, contrasts	8.3.1.4.2.1.2
			Statistical analysis crossplots, geophysical measurements	8.3.1.4.2.1.3
			Thickness, ash-flow zones	8.3.1.4.2.2.1
			Thickness, bedded-tuff zones	8.3.1.4.2.2.1
			Thickness, volcanic section, from electromagnetic surveys	8.3.1.4.2.1.2
			Transport history, ash-flow tuffs	8.3.1.4.2.2.1
			Variability, lateral, lithostratigraphic units	8.3.1.4.2.1.1
1.1	8.3.5.13	Rock-unit	Alteration history, ash-flow tuffs	8.3.1.4.2.2.1
4.4	8.3.2.5	mineralogy and petrology	Alteration, degree and type, lithostratigraphic units	8.3.1.4.2.1.1
			Clay concentrations, from induced polarization data	8.3.1.4.2.1.4
			Compositional changes, anomalous, subunit contacts	8.3.1.4.2.1.5
			Cooling history, ash-flow tuffs	8.3.1.4.2.2.1
			Curie temperature	8.3.1.4.2.1.5
			Demagnetization, alternating field	8.3.1.4.2.1.5
			Demagnetization, thermal	8.3.1.4.2.1.5
			Depositional breaks, locations, flow units	8.3.1.4.2.1.5
			Essential minerals, abundance	8.3.1.4.2.1.1

8.3.1.4-7

CONSULTATION DRAFT

Table 8.3.1.4-1. Activity parameters provided by the rock characteristics program that support performance and design issues (page 5 of 12)

Calls by performance and design issues		Parameter category	Response by rock characteristics program	
Issue	SCP section		Activity parameter	SCP activity
			Gamma-radiation intensity temperature, relative	8.3.1.4.2.1.3
			Glassy intervals, lithostratigraphic units	8.3.1.4.2.1.1
			Grain size, bedded-tuff intervals, lithostratigraphic units	8.3.1.4.2.1.1
			Grain size, variations, flow units	8.3.1.4.2.1.5
			Induced polarization	8.3.1.4.2.1.3
			Isotopes, gamma-ray spectrometry	8.3.1.4.2.1.1
			Magnetic minerals, composition	8.3.1.4.2.1.5
			Magnetic minerals, grain size	8.3.1.4.2.1.5
			Magnetic minerals, grain size variation	8.3.1.4.2.1.5
			Magnetic minerals, relative abundance	8.3.1.4.2.1.5
			Magnetization, anhysteritic remanent	8.3.1.4.2.1.5
			Magnetization, isothermal remanent	8.3.1.4.2.1.5
			Magnetization, remanent, orientation and magnitude	8.3.1.4.2.1.5
			Magnetization, saturation	8.3.1.4.2.1.5
			Mineral phases, diagenetic, bedded tuffs	8.3.1.4.2.1.1
			Mineral phases, diagenetic, bedded tuffs	8.3.1.4.2.1.1
			Mineral phases, distinctive morphologies	8.3.1.4.2.1.1
			Mineralogy, bedded-tuff units	8.3.1.4.2.1.1
			Mineralogy, lithostratigraphic units	8.3.1.4.2.1.1
			Paleomagnetic directions, lithostratigraphic units	8.3.1.4.2.1.5
			Petrography, lithostratigraphic units	8.3.1.4.2.1.1

Table 8.3.1.4 1. Activity parameters provided by the rock characteristics program that support performance and design issues (page 6 of 12)

Calls by performance and design issues		Parameter category	Response by rock characteristics program	
Issue	SCP section		Activity parameter	SCP activity
			Petrography, stratigraphic sequence	8.3.1.4.2.2.4
			Potassium, uranium, thorium content	8.3.1.4.2.1.3
			Primary crystallization, lithostratigraphic units	8.3.1.4.2.1.1
			Smectite-rich intervals, geophysical signatures	8.3.1.4.2.1.3
			Sorting, bedded-tuff units	8.3.1.4.2.1.1
			Sorting, lithostratigraphic units	8.3.1.4.2.1.1
			Spherulitic zones, lithostratigraphic units	8.3.1.4.2.1.1
			Textural variation, across flow-unit boundaries	8.3.1.4.2.1.5
			Texture, lithostratigraphic units	8.3.1.4.2.1.1
			Welding characteristics, anomalous, subunit contacts	8.3.1.4.2.1.5
			Welding, lithostratigraphic units	8.3.1.4.2.1.1
			Zeolite-rich intervals, geophysical signatures	8.3.1.4.2.1.3
			Zeolites, concentrations, from induced polarization	8.3.1.4.2.1.4
FRACTURE GEOMETRY AND PROPERTIES				
1.1	8.3.5.13	Fracture distribution	Fractal analysis	8.3.1.4.2.2.2
1.6	8.3.5.12		Fracture characteristics, spatial variation	8.3.1.4.2.2.6
1.11	8.3.2.2			
1.12	8.3.3.2		Fracture distribution, spatial	8.3.1.4.2.2.2
4.4	8.3.2.5		Fracture frequency, apparent, lateral variability	8.3.1.4.2.2.3

8.3.1.4-9

CONSULTATION DRAFT

Table 8.3.1.4-1. Activity parameters provided by the rock characteristics program that support performance and design issues (page 7 of 12)

Calls by performance and design issues		Parameter category	Response by rock characteristics program	
Issue	SCP section		Activity parameter	SCP activity
			Fracture frequency, variation with depth	8.3.1.4.2.2.3
			Fracture frequency, variation with lithostratigraphic unit	8.3.1.4.2.2.3
			Fracture location	8.3.1.4.2.2.3
			Fracture network geometry	8.3.1.4.2.2.2
			Fracture network, three-dimensional distribution, exploratory shaft facility	8.3.1.4.2.2.4
			Fracture networks	8.3.1.4.2.2.2
			Fracture patterns, local, variations	8.3.1.4.2.2.2
			Fracture, spatial distribution	8.3.1.4.2.2.4
			Fractures, subsurface, near fault zones, lateral variability	8.3.1.4.2.2.3
			Seismic properties, relation to fracture properties	8.3.1.4.2.2.6
			Seismic shear-wave amplitudes	8.3.1.4.2.2.6
			Seismic shear-wave polarizations	8.3.1.4.2.2.6
			Seismic shear-wave travel times	8.3.1.4.2.2.6
			Seismic-wave propagation characteristics	8.3.1.4.2.2.6
1.6	8.3.5.12	Fracture orientation	Fracture attitude, statistical distribution	8.3.1.4.2.2.3
1.11	8.3.2.2		Fracture attitude, variation with depth	8.3.1.4.2.2.3
4.4	8.3.2.5		Fracture attitude, variation with lithostratigraphic unit	8.3.1.4.2.2.3
			Fracture orientation	8.3.1.4.2.2.2
			Fracture orientation	8.3.1.4.2.2.3

8.3.1.4-10

CONSULTATION DRAFT

Table 8.3.1.4-1. Activity parameters provided by the rock characteristics program that support performance and design issues (page 8 of 12)

Calls by performance and design issues		Parameter category	Response by rock characteristics program	
Issue	SCP section		Activity parameter	SCP activity
			Fracture orientation, statistical distribution	8.3.1.4.2.2.2
			Fracture orientation, statistical distribution	8.3.1.4.2.2.4
			Fracture strike direction, lateral variability	8.3.1.4.2.2.3
1.6	8.3.5.12	Fracture aperture	Fracture aperture	8.3.1.4.2.2.2
1.11	8.3.2.2		Fracture aperture	8.3.1.4.2.2.3
4.4	8.3.2.5		Fracture aperture	8.3.1.4.2.2.4
1.6	8.3.5.12	Fracture length	Fracture connectivity	8.3.1.4.2.2.2
1.11	8.3.2.2		Fracture dimension, maximum	8.3.1.4.2.2.3
4.4	8.3.2.5		Fracture intersections, distribution	8.3.1.4.2.2.2
			Fracture trace length	8.3.1.4.2.2.2
			Fracture trace length, statistical distribution	8.3.1.4.2.2.4
1.11	8.3.2.2	Fracture-filling mineralogy and physical properties	Fracture mineralization, degree	8.3.1.4.2.2.3
4.4	8.3.2.5		Fracture mineralization, relation to orientation	8.3.1.4.2.2.5
			Fracture roughness	8.3.1.4.2.2.2
			Fracture roughness	8.3.1.4.2.2.4
			Fracture roughness coefficient	8.3.1.4.2.2.3
			Fracture surface profile	8.3.1.4.2.2.3
			Fracture types	8.3.1.4.2.2.3
			Fracture-filling ages, potassium-argon dates, clay coatings	8.3.1.4.2.2.5
		Fracture-filling mineralogy	8.3.1.4.2.2.2	

8.3.1.4-11

CONSULTATION DRAFT

Table 8.3.1.4-1. Activity parameters provided by the rock characteristics program that support performance and design issues (page 9 of 12)

Calls by performance and design issues		Parameter category	Response by rock characteristics program	
Issue	SCP section		Activity parameter	SCP activity
			Fracture-filling mineralogy	8.3.1.4.2.2.3
			Fracture-filling mineralogy	8.3.1.4.2.2.4
			Fracture-filling mineralogy, fracture coatings	8.3.1.4.2.2.5
FAULT GEOMETRY AND PROPERTIES				
1.1	8.3.5.13	Fault location	Fault location	8.3.1.4.2.2.3
1.6	8.3.5.12		Fault trends, from electromagnetic surveys	8.3.1.4.2.1.2
1.11	8.3.2.2		Structural domains	8.3.1.4.2.2.4
4.4	8.3.2.5		Structural rotations, magnitude from paleomagnetic directions	8.3.1.4.2.1.5
			Tectonic style, faults	8.3.1.4.2.2.4
			Tectonic style, faults, Ghost Dance fault	8.3.1.4.2.2.4
1.1	8.3.5.13	Fault orientation	Fault and fault-zone attitude	8.3.1.4.2.2.1
1.6	8.3.5.12		Fault orientation	8.3.1.4.2.2.4
1.11	8.3.2.2		Structural rotations, magnitude from paleomagnetic directions	8.3.1.4.2.1.5
4.4	8.3.2.5			
1.1	8.3.5.13	Fault length and width	Fault and fault length	8.3.1.4.2.2.1
1.6	8.3.5.12		Fault-zone length and width	8.3.1.4.2.1.2
1.11	8.3.2.2		Fault-zone width	8.3.1.4.2.2.1
4.4	8.3.2.5		Fault-zone width	8.3.1.4.2.2.3

8.3.1.4-12

CONSULTATION DRAFT

Table 8.3.1.4-1. Activity parameters provided by the rock characteristics program that support performance and design issues (page 10 of 12)

Calls by performance and design issues		Parameter category	Response by rock characteristics program		
Issue	SCP section		Activity parameter	SCP activity	
1.11	8.3.2.2	Fault displacement	Fault displacement, deep-seated faults, indication from lateral discontinuities	8.3.1.4.2.1.2	
2.3	8.3.5.5		Fault displacement, faults and fault zones	8.3.1.4.2.2.1	
4.4	8.3.2.5			Strike-slip faults, indications from lateral discontinuities	8.3.1.4.2.1.2
				Structural domains	8.3.1.4.2.2.4
				Tectonic styles, faults	8.3.1.4.2.2.4
				Tectonic styles, faults, Ghost Dance fault	8.3.1.4.2.2.4
4.4	8.3.2.5	Fault-zone mineralogy and physical properties	Alteration characteristics, fault zones	8.3.1.4.2.1.2	
			Fault and fault-zone characteristics, near-surface faults and zones	8.3.1.4.2.2.1	
			Fault physical characteristics	8.3.1.4.2.2.4	
			Fault-zone hydraulic connectivity, from alteration zones	8.3.1.4.2.1.2	
GEOLOGIC FRAMEWORK					
1.1	8.3.5.13	Geologic framework	Correlation diagrams, lithostratigraphic units	8.3.1.4.2.3.1	
1.6	8.3.5.12		Correlation of laboratory values and in situ values for rock properties	8.3.1.4.2.3.1	
1.11	8.3.2.2			Cross sections, lithostratigraphic units	8.3.1.4.2.3.1
1.12	8.3.3.2				8.3.1.4.2.3.1
4.4	8.3.2.5				

8.3.1.4-13

CONSULTATION DRAFT

Table 8.3.1.4-1. Activity parameters provided by the rock characteristics program that support performance and design issues (page 11 of 12)

Calls by performance and design issues		Parameter category	Response by rock characteristics program	
Issue	SCP section		Activity parameter	SCP activity
			Fractures, spatial distribution	8.3.1.4.2.3.1
			Fractures, spatial distribution	8.3.1.4.2.3.1
			Geologic model, three-dimensional	8.3.1.4.2.3.1
			Interpretation of depositional and diagenetic history of rock units	8.3.1.4.2.3.1
			Interpretation of distribution of lithology, petrology, petrography, and mineralogy of rock units	8.3.1.4.2.3.1
			Isopach maps, lithostratigraphic units	8.3.1.4.2.3.1
			Isopleth maps, rock property values	8.3.1.4.2.3.1
			Relations between geologic and geophysical characteristics of rock units	8.3.1.4.2.3.1
			Rock properties, three-dimensional distribution	8.3.1.4.2.3.1
			Structure contour maps, lithostratigraphic units	8.3.1.4.2.3.1
			Surface geologic maps	8.3.1.4.2.3.1
GEOLOGIC MODEL				
1.1	8.3.5.13	Geologic model synthesis	Age, fracturing	8.3.1.4.2.2.4
1.6	8.3.5.12		Age, fracturing	8.3.1.4.2.2.5
1.11	8.3.2.2		Chronology, faulting	8.3.1.4.2.2.1
1.12	8.3.3.2		Chronology, faulting, relative	8.3.1.4.2.2.3
4.4	8.3.2.5		Faulting chronology	8.3.1.4.2.2.1
			Fracture age, ESR dates, quartz	8.3.1.4.2.2.5

8.3.1.4-14

CONSULTATION DRAFT

Table 8.3.1.4-1. Activity parameters provided by the rock characteristics program that support performance and design issues (page 12 of 12)

Calls by performance and design issues		Parameter category	Response by rock characteristics program	
Issue	SCP section		Activity parameter	SCP activity
			Fracture age, uranium-thorium, calcite, uraniferous opal	8.3.1.4.2.2.5
			Fracture chronology, fracture development	8.3.1.4.2.2.2
			Fracture chronology, relative changes due to tectonism--see tectonism studies	8.3.1.4.2.2.3 8.3.1.8.2
			Fracture chronology, relative changes due to erosion--see erosion studies	8.3.1.6.4.1
			Saturation	8.3.1.4.2.1.3
			Water content	8.3.1.4.2.1.3
			Relationships among hydrologic test results, VSP fracture data and lithologic data	8.3.1.4.2.2.6
			Relationships among geochemical test results, VSP fracture data, and lithologic data	8.3.1.4.2.2.6
			Poisson's ratio	8.3.1.4.2.1.3
			Young's modulus	8.3.1.4.2.1.3
			Relationships among geomechanical test results, VSP fracture data, and lithologic data	8.3.1.4.2.2.6

8.3.1.4-15

CONSULTATION DRAFT

CONSULTATION DRAFT

associated goals, in some cases for the same parameter type within a given category. Thus, the parameter categories are defined to properly correlate sets of related design or performance parameters with corresponding sets of characterization parameters.

Table 8.3.1.4-1 lists activity parameters associated with each parameter category that incorporates information provided by the Rock Characteristics Program. The following explanation is provided to summarize the types of design and performance parameters encompassed by each category.

The table entries labelled "rock unit geometry and properties," "fracture geometry and properties," "fault geometry and properties," and "geologic framework" each represents a broad group of geologic and geophysical information (Figure 8.3.1.4-1). "Rock unit geometry and properties" is divided into three parameter categories: rock unit contact location and configuration; rock unit lateral and vertical variability; and rock unit mineralogy and petrology. The performance and design parameters associated with "rock unit contact location and configuration" include such items as unit contact attitudes for geohydrologic, geochemical, thermomechanical, and lithologic units; thickness of the Topopah Spring and other rock units; lateral extent of thermomechanical units; attitudes of various units; and depths to various unit contacts. Rock unit lateral and vertical variability includes such performance and design parameters as spatial correlation scales for hydrologic and geochemical properties, and extent and abundance of lithophysal cavities in the Topopah Spring Member. The category "rock unit mineralogy and petrology" combines requests for site information on such parameters as calcite cementation above the repository, radionuclide concentrations, and mineralogy around the waste packages.

The second group of parameter categories, "fracture geometry and properties," addresses information about the fracture network of Yucca Mountain. It includes five parameter categories. The first, "fracture distribution," includes design and performance requests primarily for fracture frequency, spacing, and abundance, as well as for spatial distribution to aid classification of fracture and joint sets. The second category, "fracture orientation," is self explanatory and provides a rare one-to-one match with performance and design requests. The next category in this group, "fracture aperture," includes requests for fracture widths and their local spatial distribution. The category for "fracture length" includes requests for fracture persistence, as well as fracture length. The last category in this group, "fracture filling mineralogy and physical properties," includes parameter requests for such items as roughness coefficients of fracture walls, distribution and concentrations of fracture fillings in the repository, and fracture weathering information in the Topopah Spring Member.

The next broad group of parameters categories, "fault geometry and properties," deals with the characteristics of faults and fault zones. The first four of these categories are self-explanatory and summarize design and performance requests for information on fault locations, orientations, length and width, and displacement. The fifth and last entry, "fault zone mineralogy and physical properties," has no specific corresponding requests from design and performance issues that are directly addressed by the characterization program for rock characteristics. The hydrological, thermomechanical, and geochemical properties of rock materials within fault zones are

CONSULTATION DRAFT

requested, but are listed under parameter categories for the type of property (e.g., permeability or retardation coefficient) in the appropriate characterization program (Sections 8.3.1.2, geohydrology program; 8.3.1.3, geochemistry program; and 8.3.1.15, thermal and mechanical properties program). Also, several requests for information relating to faulting potential and to location of faults with such potential are not listed here but are addressed in the sections on postclosure tectonics (Section 8.3.1.8) and in preclosure tectonics (Section 8.3.1.17).

The last general category of parameters, "geologic framework," represents a set of synthesized parameters that will eventually constitute "characterization parameters." The form and content of these parameters are under development but will provide a vehicle for reducing the data represented by "activity parameters" to a proper form for transfer to uses in design and performance analysis.

As previously mentioned, a three-dimensional model could be developed based only on physical property data from core samples. Various interpolation methods can be used to estimate the variation in the value of a property of the rock between the locations of the samples. The use of the rock property data determines the degree to which it is important to know precisely how a particular property varies with the distance from the sample location. For example, if a hydrologic numerical model for calculating ground-water travel time requires a value for the effective permeability, several considerations will determine how well effective permeability must be known. First, the question of what level of uncertainty on travel time is acceptable should be addressed. Second, the sensitivity of the travel-time calculation to the effective permeability must be determined. If the travel time is very sensitive to permeability and the uncertainty associated with the calculation must be small, activities to obtain additional information to better describe the spatial variability of the parameter are justified. The planned geologic and geophysical studies are intended to identify correlations between the properties of interest that can be directly measured and other properties that must be estimated. The results of the geologic studies will therefore be used to calibrate the geophysical data and provide additional sources for correlating parameter information.

Interrelationships of rock characteristics investigations

This characterization program has been divided into three investigations: (1) development of an integrated drilling program, Investigation 8.3.1.4.1; (2) geologic framework of the Yucca Mountain site, Investigation 8.3.1.4.2; and (3) development of three dimensional models of rock characteristics at the repository site, Investigation 8.3.1.4.3. Feeding into Investigation 8.3.1.4.3 will be the results of investigations in Section 8.3.1.2 (geohydrology), Section 8.3.1.15 (thermal and mechanical rock properties) and Section 8.3.1.3 (geochemistry).

The schedule information provided for investigations in this section includes the sequencing, interrelationships, and relative durations of the studies in the investigation. Specific durations and start/finish dates for the studies are being developed as part of ongoing planning efforts and will be provided in the SCP at the time of issuance and revised as appropriate in subsequent semiannual progress reports.

CONSULTATION DRAFT

8.3.1.4.1 Investigation: Development of an integrated drilling program

Technical basis for obtaining the information

Link to the technical data chapters and applicable support documents

A summary of previous NNWSI Project drilling is contained in Chapter 1, Section 1.6 (drilling and mining).

Purpose and objectives of the investigation

Drilling is an integral portion of many investigations which are planned to obtain information needed for repository design and performance assessment. The specific activities and proposed boreholes are summarized in Table 8.3.1.4-2 and shown on Figure 8.3.1.4-2. Proposed boreholes are currently sited on the basis of two differing strategies: (1) characterize anomalies and gather data on subsurface conditions by siting of boreholes in order to sample known or inferred features of interest and (2) characterize the statistical distribution of needed parameters by random or gridded siting of boreholes to sample an entire volume of interest, without consideration of specific geologic features or known subsurface data. The overall purpose of the integration of drilling activities will be to most effectively meet the needs of the NNWSI Project.

To this end, the integration of borehole siting, sampling, and testing has several objectives that will be optimized by consideration of applicable tradeoffs: (1) coordinate sampling and testing programs to reduce redundant sampling and testing; (2) minimize both the potential alteration of ambient surface and subsurface conditions within the repository environment and the creation of possible preferential pathways caused by drilling that need to be sealed as required by 10 CFR 60.134; (3) ensure that drilling and sampling methods are well matched to applicable technical, regulatory, and scientific requirements; (4) maximize cost-effectiveness of drilling program; and (5) maximize returns from drilling in order to increase both sampling of the subsurface volume of interest and data returns from in situ monitoring activities. Each drill hole proposed in various site characterization programs (see Table 8.3.1.4-2 and Figure 8.3.1.4-2) represents a source for data intended to answer a particular requirement of design or performance assessment. Where feasible, objectives for separate, currently planned holes may be combined, if appropriate data can be obtained from a single hole. The process of integrating proposed drilling may result in the addition of new drill holes or deletion of previously scheduled holes as result of data obtained from completed studies and activities.

Technical rationale for the investigation

Drilling will provide physical samples of the subsurface materials and access to locations for long- and short-term subsurface testing and monitoring that will augment existing boreholes. However, drilling proposed in this document will require resolution of various regulatory and technical questions. These questions involve the impact of possible contamination of the unsaturated zone by water-based drilling fluids and whether holes should be drilled through the primary repository area to the saturated zone. This

CONSULTATION DRAFT

Table 8.3.1.4-2. Site characterization plan proposed drilling requirements
(page 1 of 4)

Hole Number	<u>Proposed depth</u> (in feet)	SCP activity	Remarks	
USW H-7	3,000	8.3.1.2.1.1	Hydrologic drilling	
VSP Support	1,800	8.3.1.2.2.2.1	Unsaturated zone drilling	
USW UZ-2	2,500	8.3.1.2.2.2.1		
USW UZ-3	1,500	8.3.1.2.2.2.1		
USW UZ-8	350	8.3.1.2.2.2.1		
USW UZ-9	2,000	8.3.1.2.2.2.1		
USW UZ-9a	1,500	8.3.1.2.2.2.1		
USW UZ-9b	1,500	8.3.1.2.2.2.1		
USW UZ-10	1,500	8.3.1.2.2.2.1		
USW UZ-11	400	8.3.1.2.2.3.1		
USW UZ-12	400	8.3.1.2.2.3.1		
USW UZ-14	400	8.3.1.2.2.2.1		
N11	50	8.3.1.2.2.1.1		Unsaturated zone neutron moisture logging
N15	50	8.3.1.2.2.1.1		
N16	50	8.3.1.2.2.1.1		
N17	50	8.3.1.2.2.1.1		
N27	50	8.3.1.2.2.1.1		
N31	50	8.3.1.2.2.1.1		
N32	50	8.3.1.2.2.1.1		
N33	50	8.3.1.2.2.1.1		
N34	50	8.3.1.2.2.1.1		
N35	50	8.3.1.2.2.1.1		
N36	50	8.3.1.2.2.1.1		
N37	50	8.3.1.2.2.1.1		
N38	50	8.3.1.2.2.1.1		
N39	50	8.3.1.2.2.1.1		
N46	50	8.3.1.2.2.1.1		
N53	50	8.3.1.2.2.1.1		
N53a	50	8.3.1.2.2.1.1		
N54	50	8.3.1.2.2.1.1		
N57	50	8.3.1.2.2.1.1		
N58	50	8.3.1.2.2.1.1		
N59	50	8.3.1.2.2.1.1		
N61	50	8.3.1.2.2.1.1		
N62	50	8.3.1.2.2.1.1		
N63	50	8.3.1.2.2.1.1		
N64	50	8.3.1.2.2.1.1		
LPRS1	<35 (10 holes)	8.3.1.2.2.1.1	Large plot rainfall simulation study	
LPRS2	<35 (10 holes)	8.3.1.2.2.1.1		
LPRS3	<35 (10 holes)	8.3.1.2.2.1.1		
LPRS4	<35 (10 holes)	8.3.1.2.2.1.1		

CONSULTATION DRAFT

Table 8.3.1.4-2. Site characterization plan proposed drilling requirements
(page 2 of 4)

Hole Number	<u>Proposed depth</u> (in feet)	SCP activity	Remarks
LPRS5	<35 (10 holes)	8.3.1.2.2.1.1	
LPRS6	<35 (10 holes)	8.3.1.2.2.1.1	
LPRS7	<35 (10 holes)	8.3.1.2.2.1.1	
LPRS8	<35 (10 holes)	8.3.1.2.2.1.1	
LPRS9	<35 (10 holes)	8.3.1.2.2.1.1	
LPRS10	<35 (10 holes)	8.3.1.2.2.1.1	
LPRS11	<35 (10 holes)	8.3.1.2.2.1.1	
LPRS12	<35 (10 holes)	8.3.1.2.2.1.1	
LPRS13	<35 (10 holes)	8.3.1.2.2.1.1	
LPRS14	<35 (10 holes)	8.3.1.2.2.1.1	
SPRS1	<5 (4 holes)	8.3.1.2.2.1.1	Small plot rainfall simulation study
SPRS2	<5 (4 holes)	8.3.1.2.2.1.1	
SPRS3	<5 (4 holes)	8.3.1.2.2.1.1	
SPRS4	<5 (4 holes)	8.3.1.2.2.1.1	
SPRS5	<5 (4 holes)	8.3.1.2.2.1.1	
SPRS6	<5 (4 holes)	8.3.1.2.2.1.1	
SPRS7	<5 (4 holes)	8.3.1.2.2.1.1	
SPRS8	<5 (4 holes)	8.3.1.2.2.1.1	
SPRS9	<5 (4 holes)	8.3.1.2.2.1.1	
SPRS10	<5 (4 holes)	8.3.1.2.2.1.1	
SPRS11	<5 (4 holes)	8.3.1.2.2.1.1	
SPRS12	<5 (4 holes)	8.3.1.2.2.1.1	
SPRS13	<5 (4 holes)	8.3.1.2.2.1.1	
SPRS14	<5 (4 holes)	8.3.1.2.2.1.1	
SPRS15	<5 (4 holes)	8.3.1.2.2.1.1	
SPRS16	<5 (4 holes)	8.3.1.2.2.1.1	
SPRS17	<5 (4 holes)	8.3.1.2.2.1.1	
SPRS18	<5 (4 holes)	8.3.1.2.2.1.1	
SPRS19	<5 (4 holes)	8.3.1.2.2.1.1	
SPRS20	<5 (4 holes)	8.3.1.2.2.1.1	
SPRS21	<5 (4 holes)	8.3.1.2.2.1.1	
SPRS22	<5 (4 holes)	8.3.1.2.2.1.1	
SPRS23	<5 (4 holes)	8.3.1.2.2.1.1	
USW WT-8	2,200	8.3.1.2.3.1.1	Water table drilling
USW WT-9	2,200	8.3.1.2.3.1.1	
UE25 WT-19	1,100	8.3.1.2.3.1.2	
UE25 WT-20	1,100	8.3.1.2.3.1.2	
UE25 WT-21	1,800	8.3.1.2.3.1.2	
USW WT-22	1,300	8.3.1.2.3.1.2	
USW WT-23	2,200	8.3.1.2.3.1.2	
USW WT-24	2,200	8.3.1.2.3.1.2	

CONSULTATION DRAFT

Table 8.3.1.4-2. Site characterization plan proposed drilling requirements
(page 3 of 4)

Hole Number	<u>Proposed depth</u> (in feet)	SCP activity	Remarks
FMN-1	>33	8.3.1.2.1.3.3	Neutron moisture logging as part of Fortymile Wash recharge study
FMN-2	>33	8.3.1.2.1.3.3	
FMN-3	>33	8.3.1.2.1.3.3	
FMN-4	>33	8.3.1.2.1.3.3	
FMN-5	>33	8.3.1.2.1.3.3	
FMN-6	>33	8.3.1.2.1.3.3	
FMN-7	>33	8.3.1.2.1.3.3	
FMN-8	>33	8.3.1.2.1.3.3	
FMN-9	>33	8.3.1.2.1.3.3	
FMN-10	>33	8.3.1.2.1.3.3	
UE25 FM#1	500	8.3.1.2.1.3.3	Fortymile Wash recharge study
UE25 FM#2	500	8.3.1.2.1.3.3	
UE25 FM#3	500	8.3.1.2.1.3.3	
STC-1	3,000	8.3.1.2.3.1.6	Southern Tracer Complex test holes; drilling decision based on C-hole Complex tests
STC-2	3,000	8.3.1.2.3.1.6	
STC-3	3,000	8.3.1.2.3.1.6	
STC-4	3,000	8.3.1.2.3.1.6	
SH-1	1,000	8.3.1.2.2.2.1.2	Solitario Canyon horizontal hole
USW G-5	5,000	8.3.1.4.2.1.1	Geologic drilling
USW G-6	5,000	8.3.1.4.2.1.1	
USW G-7	5,000	8.3.1.4.2.1.1	
USW SD-1	2,000	8.3.1.4.3.1	Sandia National Laboratories Performance Assessment-based drilling program SD-13 to SD-24 to be drilled only if results from SD-1 to SD-12 continued drilling
USW SD-2	2,000	8.3.1.4.3.1	
USW SD-3	2,000	8.3.1.4.3.1	
USW SD-4	2,000	8.3.1.4.3.1	
UE25 SD#5	2,000	8.3.1.4.3.1	
USW SD-6	2,000	8.3.1.4.3.1	
USW SD-7	2,000	8.3.1.4.3.1	
UE25 SD#8	2,000	8.3.1.4.3.1	
USW SD-9	2,000	8.3.1.4.3.1	
USW SD-10	2,000	8.3.1.4.3.1	
USW SD-11	2,000	8.3.1.4.3.1	
USW SD-12	2,000	8.3.1.4.3.1	
USW SD-13	2,000	8.3.1.4.3.1	
USW SD-14	2,000	8.3.1.4.3.1	
USW SD-15	2,000	8.3.1.4.3.1	
USW SD-16	2,000	8.3.1.4.3.1	
USW SD-17	2,000	8.3.1.4.3.1	

CONSULTATION DRAFT

Table 8.3.1.4-2. Site characterization plan proposed drilling requirements
(page 4 of 4)

Hole Number	<u>Proposed depth</u> (in feet)	SCP activity	Remarks
USW SD-18	2,000	8.3.1.4.3.1	
USW SD-19	2,000	8.3.1.4.3.1	
USW SD-20	2,000	8.3.1.4.3.1	
USW SD-21	2,000	8.3.1.4.3.1	
USW SD-22	2,000	8.3.1.4.3.1	
UE25 SD#23	2,000	8.3.1.4.3.1	
USW SD-24	2,000	8.3.1.4.3.1	
UE#25 SF#11	300	8.3.1.14.2.1	Engineering drilling for repository surface facilities construction
UE25 SF#2	300	8.3.1.14.2.1	
UE25 PH#1A	60 (5 holes)	8.3.1.5.2.1.5	Calcite-silica drilling
UE25 PH#1B	260	8.3.1.5.2.1.5	
V-1	1,000	8.3.1.8.5.1.1	Volcanic K-Ar drilling
V-2	1,000	8.3.1.8.5.1.1	
V-3	1,000	8.3.1.8.5.1.1	
V-4	1,000	8.3.1.8.5.1.1	
USW ISS-1	1,000	8.3.1.17.4.8.2	In situ stress drill- ing USW ISS-3 through USW ISS-22 based on results of USW ISS-1 and USW ISS-2
USW ISS-2	1,000	8.3.1.17.4.8.2	
USW ISS-3	1,000	8.3.1.17.4.8.2	
USW ISS-4	1,000	8.3.1.17.4.8.2	
USW ISS-5	1,000	8.3.1.17.4.8.2	
USW ISS-6	1,000	8.3.1.17.4.8.2	
USW ISS-7	1,000	8.3.1.17.4.8.2	
USW ISS-8	1,000	8.3.1.17.4.8.2	
USW ISS-9	1,000	8.3.1.17.4.8.2	
USW ISS-10	1,000	8.3.1.17.4.8.2	
USW ISS-11	1,000	8.3.1.17.4.8.2	
USW ISS-12	1,000	8.3.1.17.4.8.2	
USW ISS-13	1,000	8.3.1.17.4.8.2	
USW ISS-14	1,000	8.3.1.17.4.8.2	
USW ISS-15	1,000	8.3.1.17.4.8.2	
USW ISS-16	1,000	8.3.1.17.4.8.2	
USW ISS-17	1,000	8.3.1.17.4.8.2	
USW ISS-18	1,000	8.3.1.17.4.8.2	
USW ISS-19	1,000	8.3.1.17.4.8.2	
USW ISS-20	1,000	8.3.1.17.4.8.2	
USW ISS-21	1,000	8.3.1.17.4.8.2	
USW ISS-22	1,000	8.3.1.17.4.8.2	

CONSULTATION DRAFT

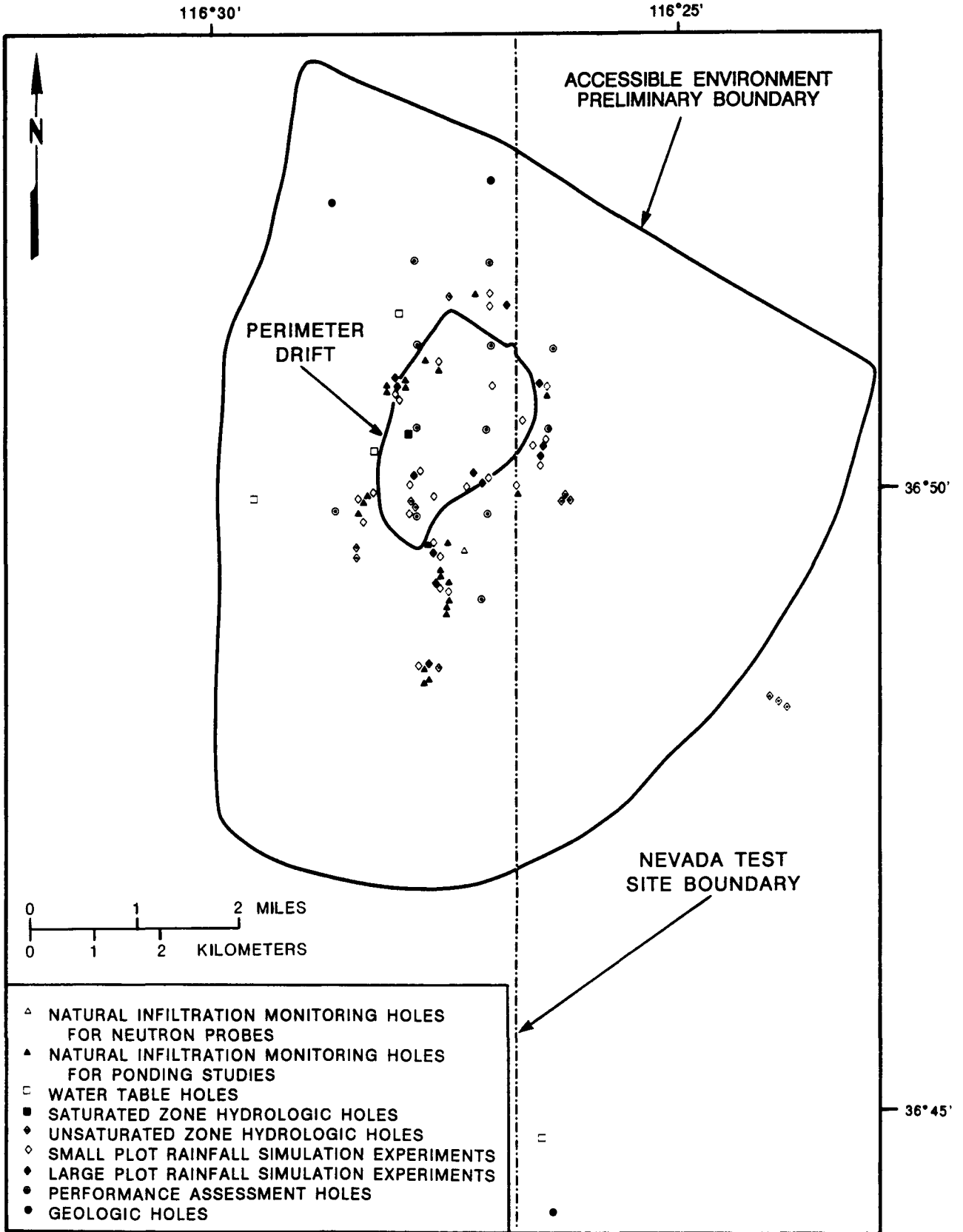

Figure 8.3.1.4-2. Proposed boreholes for site characterization.

CONSULTATION DRAFT

investigation will evaluate the scientific, regulatory and technical concerns associated with the proposed drilling, and will lay out a plan for integrating NNWSI Project drilling throughout site characterization.

8.3.1.4.1.1 Study: Develop positions on drilling issues that pertain to site characterization

The objective of this study is to investigate the various technical, regulatory, and scientific questions that have been raised concerning the drilling proposed in this document.

Activities planned for this study will: (1) develop and apply technical and regulatory positions on drilling through the waste emplacement area; (2) analyze the potential effects of wet borehole construction on the unsaturated zone; (3) assess the impacts on design and performance assessment if core samples cannot be recovered from the repository horizon and below because of adverse impacts determined as a result of items (1) and (2); (4) investigate alternative scheduling or methods for drilling and coring using dry drilling techniques that are different from those used in previous drilling; and (5) apply statistical methods to the existing data as an aid to determining the need for, and potential siting of, future drill holes.

8.3.1.4.1.1.1 Activity: Develop a position on drilling within the boundaries of the repository perimeter drift

Objectives

The objective of this activity is to determine if plans for drilling holes that will penetrate the repository horizon and extend below the water table may be precluded by existing regulations.

Parameters

Existing regulations covering site characterization.

Description

This activity will review the available data, technical analyses, modeling results, preliminary performance assessment calculations and existing regulations to document the regulatory and technical arguments for and against drilling that penetrate the repository horizon and reach the saturated zone within the boundary of the repository perimeter drift. The regulatory review will include the Nuclear Waste Policy Act of 1982, 10 CFR Part 60, 10 CFR Part 960, U.S. Nuclear Regulatory Commission Regulatory Guide 1.132, and 40 CFR Part 191.

The product of this activity will be a project position paper discussing the regulatory concerns pertaining to drilling within the boundary of the repository as defined by the perimeter drift. The report will develop a DOE

CONSULTATION DRAFT

position on the rationale and methodology for addressing these concerns in the performance of the overall site characterization program.

8.3.1.4.1.1.2 Activity: The effects of drilling boreholes on the unsaturated zone using water, mud, or air foam as a drilling circulation medium

The objective of this activity is to evaluate, through various subactivities, the potential problems associated with drilling and coring in the unsaturated zone posed by either the use or prohibition of use of conventional water-based drilling fluids. Four subactivities are included in this activity.

8.3.1.4.1.1.2.1 Subactivity: The effect of use of water-based drilling fluids

Objectives

The objective of this subactivity is to analyze the effects on hydrologic characterization of the unsaturated zone caused by the use of conventional circulation media such as drilling mud or foam in drillholes conducted before site characterization.

Parameters

There are no parameters for this subactivity.

Description

During pre-site characterization investigations, approximately 35 boreholes were drilled to depths >1,000 ft using a variety of drilling techniques, including extensive use of water-based polymer mud and air foam. Some preliminary assessment of the effects of drilling these holes has been made (Montazer, 1985, 1986). This subactivity will consider the amount of drilling fluid that has been introduced into the unsaturated zone as a result of the previous boreholes and the effects of the introduction of this fluid into the unsaturated zone.

The product of this subactivity will be a topical report describing the projected relative impact on site characterization studies of the unsaturated zone caused by past and continued use of water-based drilling fluids.

8.3.1.4.1.1.2.2 Subactivity: Evaluation of data losses to design and performance assessment caused by drilling restrictions

Objectives

The objective of this subactivity is to assess the potential loss of

CONSULTATION DRAFT

data for design and performance assessment issues, resulting from a decision not to use water-based drilling fluid in constructing coreholes in the unsaturated zone.

Parameters

There are no parameters for this subactivity.

Description

Drilling conducted before site characterization demonstrated the feasibility of drilling coreholes to 500 ft depth using only compressed air as the circulation medium. An analysis will be made to assess the effects to performance assessment and design issues incurred if it is not feasible to return core from >500 ft total depth by dry drilling methods. This analysis should consider, but not be limited to, the particular impacts that will result if no data or only poorly constrained data exist for the rock units critical to construction of the proposed repository or to assessment of critical performance measures.

This subactivity will produce a topical report detailing the results of the analysis and developing a DOE position on the need for returning core samples from depths >500 ft.

8.3.1.4.1.1.2.3 Subactivity: Review of alternate methods for dry drilling for core recovery below 500 ft

Objectives

The objective of this subactivity is to investigate methods for recovering core from depths of more than 500 ft using a dry drilling technology different from technology currently used at the Nevada Test Site.

Parameters

There are no parameters for this subactivity.

Description

A review will be made of currently available industry practices, services, and apparatus that may be applied to deep coring using dry drilling techniques.

The expected product of this subactivity will be a written report on the results of the investigation.

CONSULTATION DRAFT

8.3.1.4.1.1.2.4 Subactivity: Investigation of alternate scheduling practices for wet drilling

Objectives

The objective of this subactivity is to determine if alternative scheduling or two-phased drilling of coreholes in the unsaturated zone may allow drilling of holes using conventional water-based drilling fluid.

Parameters

There are no parameters for this subactivity.

Description

Disturbing the ambient conditions in the unsaturated zone may be avoided if wet drillholes are begun after testing and monitoring in the unsaturated zone is complete, or if the wet holes are drilled in a phased approach, with the upper segments drilled dry and the lower segments drilled wet.

An analysis will be made to assess the applicability of alternative scheduling or construction techniques. The expected output from this subactivity will be a written report on the results of the analysis.

8.3.1.4.1.1.3 Activity: Evaluation of drillhole and other subsurface data for the purpose of siting additional drillholes

Objectives

The objective of this activity is to perform evaluations of data available from drillholes, core samples, and other geologic and geophysical studies, in order to support determination of the need, location, and technical specifications for additional drillholes.

Parameters

There are no parameters for this activity.

Description

Two distinct approaches to siting, sampling, and testing of drillholes are planned by the NNWSI Project. One approach can be described as feature-of-interest sampling, and is intended to investigate known or suspected anomalous features that are associated with processes or variation of properties that impact the safe design or performance of a repository. Investigation of such anomalies will help ensure that potential design or performance failure modes have been characterized. The other approach can be described as representative sampling, whereby the overall variation of properties is estimated using data from spatially distributed drillholes. This approach is designed to support a representative model of rock characteristics at the site, and will also provide a basis for evaluating the distribution and relative importance of anomalous features.

CONSULTATION DRAFT

The two approaches are complementary, but must be carefully integrated to ensure effective application of effort. For example, statistical evaluations of existing data may indicate that a particular location for a future drillhole will effectively reduce interpolation errors for properties of interest between drillholes, but near the statistically optimal location is a suspected anomaly. In the hypothetical example, investigation of the anomaly by drilling could resolve a licensing issue concerning possible effects on repository performance. Several drilling and sampling options would be available, including (1) drilling both locations, (2) drilling the anomaly only and using an appropriate interpretation of the results in developing the model of rock characteristics, or (3) drilling only the statistically optimal location and assuming "worst-case" properties for the suspected anomaly. In the example, the evaluation activity would consider the tradeoffs and balance the objectives of the two general sampling approaches by performing applicable statistical analysis of existing data and defining the potential licensing issues raised by the anomaly. The product of this activity will be an analysis and issues evaluation report that will be provided to Project management for action.

Another facet of this activity will address the tradeoffs between (1) maximizing sampling density within the repository area and along potential flow paths to the accessible environment, and (2) maximizing sampling of features related to genesis of tuff units and structures at the site. Favorable locations for investigating tuff genesis may not occur directly within the area of concern for design or performance assessment issues, but sampling such locations may enhance general understanding of the rock unit variability and thereby provide information for inferring properties within the area of interest. In some instances such geological inference may better address uncertainty than direct sampling. There may be no unequivocal answer to determine where and how much drilling will best address the information requirements of design and performance assessment. Therefore, this activity will draw upon statistical analysis, professional judgment, and projections of likely licensing issues to focus the options for management disposition of drillhole siting.

8.3.1.4.1.2 Study: Integration of the drilling proposed during the first year of site characterization

Objectives

The objective of this study is to integrate the drilling activities for the first year of site characterization.

Parameters

There are no parameters for this study.

Description

Using existing schedules, representatives from all appropriate participating organizations will meet to integrate drilling planned for the first

CONSULTATION DRAFT

year of site characterization. This integrating effort will include (1) considerations of the results of activities proposed in Study 8.3.1.4.1.1; (2) prioritization of boreholes based on testing and monitoring intervals required and on potential interference with testing, monitoring, and sampling activities in the unsaturated zone caused by localized effects of drilling techniques; and (3) requirements of design and performance assessment for borehole-derived data to satisfy milestones or decision points for site characterization.

8.3.1.4.1.3 Study: Ongoing integration of the NNWSI Project drilling

Objectives

The objective of this study is to continue at regular intervals to integrate the NNWSI Project drilling.

Parameters

There are no parameters for this study.

Description

Following similar guidelines proposed in Study 8.3.1.4.1.2, integration of future boreholes will be carried out by a group of representatives from all participating organizations. This effort will cover approximately one year intervals ahead of existing schedules and will consider, in addition to the criteria considered in Study 8.3.1.4.1.2, (1) the results of the previous years drilling and (2) the additional site characterization studies that either may call for changes in the scheduled drilling of additional holes or may be affected by future drilling. Of paramount importance will be the requirement of this group to factor into future borehole siting the results of the completed site characterization studies.

The product of this group will be an updated drilling schedule plus an update of affected site characterization studies on the basis of data obtained since the last revision of the drilling.

8.3.1.4.1.4 Application of results

The information derived from the studies and activities of the plans described previously will be used in the following areas of site characterization, seal systems, and performance assessment:

For site characterization, the SCP sections include

<u>Section</u>	<u>Subject</u>
8.3.1.1	Site overview
8.3.1.2	Geohydrology program
8.3.1.3	Geochemistry program

CONSULTATION DRAFT

- 8.3.1.4 Rock characteristics program
- 8.3.1.8 Postclosure tectonics program
- 8.3.1.9 Human interference program
- 8.3.1.14 Surface characteristics program
- 8.3.1.15 Thermal and mechanical rock properties program
- 8.3.2.2 Configuration of underground facilities (postclosure) program

Section 8.3.3.2 (shaft and borehole seals characteristics) uses the information for seal systems. Section 8.3.5.12 (ground-water travel time) uses the information for performance assessment.

For schedule, the SCP sections include

<u>Section</u>	<u>Subject</u>
8.5.1	Site characterization
8.5.5	Major decision points
8.5.6	Schedules

8.3.1.4.1.5 Schedule and milestones

This investigation on the integrated drilling program contains three studies: 8.3.1.4.1.1 (develop positions on drilling issues), 8.3.1.4.1.2 (integration of the drilling proposed during the first year of site characterization), and 8.3.1.4.1.3 (ongoing integration of the NNWSI Project drilling). In the figure that follows, the schedule information for these studies is presented in the form of timelines. The timelines extend to the issuance of the final products associated with the studies. Summary schedule and milestone information for this investigation can be found in Section 8.5.1.1.

In this investigation, Studies 8.3.1.4.1.1 and 8.3.1.4.1.2 are ongoing. The integration efforts of Study 8.3.1.4.1.3 will begin following completion of an integrated drilling plan for the first year of site characterization.

The studies in this investigation will evaluate the scientific, regulatory, and technical concerns associated with the proposed drilling, and will lay out a plan for integrating drilling throughout site characterization. Planning for successive years of site characterization (Study 8.3.1.4.1.3) will consider criteria considered in Study 8.3.1.4.1.2, as well as the results of the previous year's drilling and additional site characterization studies that may call for changes in the scheduled drilling or may be affected by future drilling. The implementation of Study 8.3.1.4.3.1 (systematic acquisition of site-specific subsurface information) is contingent on the results of drilling integration from the first such effort in Study 8.3.1.4.1.3.

The studies in this investigation are not constrained by other program elements and can begin when the study plan is available.

CONSULTATION DRAFT

The study numbers and titles corresponding to the timelines are shown on the left of the following figure. The points shown on the timelines represent major events or important milestones associated with the study. Solid lines represent study durations, and dashed lines show interfaces. The data input and output at the interfaces are shown by circles.

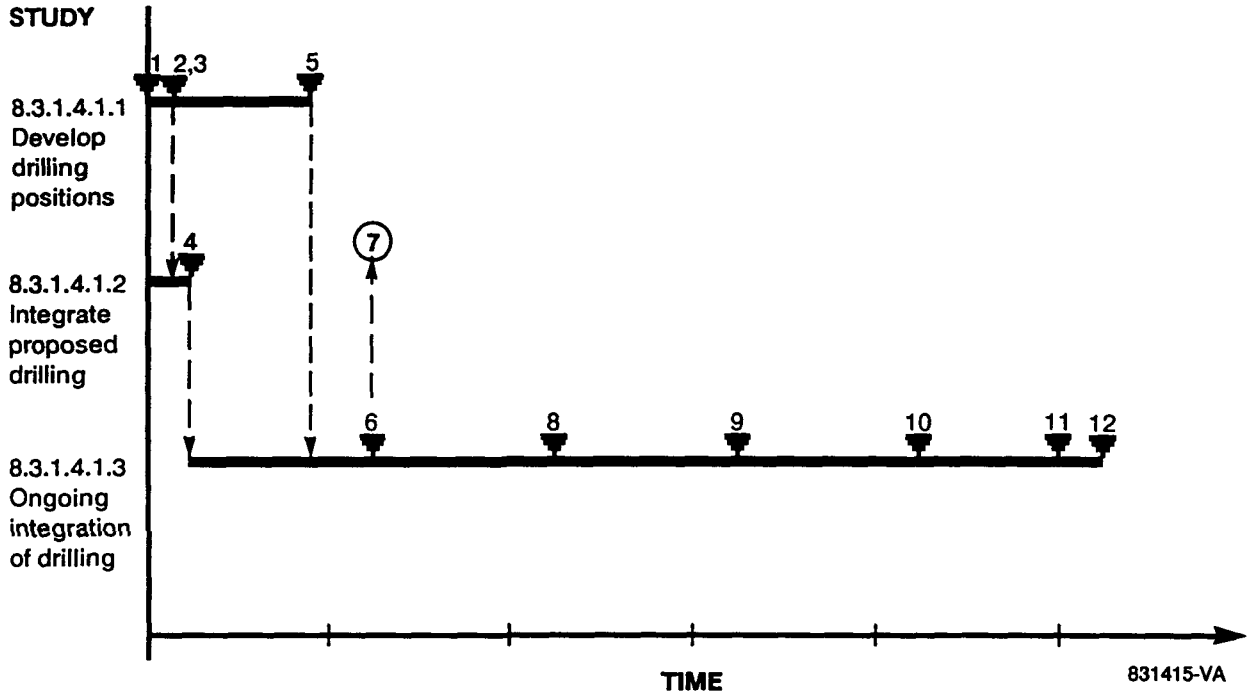

The points on the timeline and the data input and output at the interfaces are described in the following table:

<u>Point number</u>	<u>Description</u>
1	Milestone Q082. Complete technical reports on drilling concerns.
2	Milestone Q083. Decision on whether to drill within the repository block.
3	Milestone Q084. Decision on the use of drilling fluids within the repository block.
4	Milestone Q085. Produce integrated drilling plan for the first year of site characterization.

CONSULTATION DRAFT

<u>Point number</u>	<u>Description</u>
5	Milestone Q087. Evaluation of existing borehole and subsurface data for use in siting new boreholes.
6	Milestone Q094. Produce integrated drilling plans for successive years of site characterization.
7	Results of drilling integration available to Study 8.3.1.4.3.1 (systematic acquisition of site-specific subsurface information).
8-10	Milestones Q100, Q105, and Q116. Produce integrated drilling plans for successive years of site characterization.
11	Milestone Q120. Complete all borehole construction and testing for licensing application.
12	Milestone Q121. Issue final report on integration of site characterization borehole construction.

8.3.1.4.2 Investigation: Geologic framework of the Yucca Mountain site

Technical basis for obtaining the information

Link to the technical data chapters and applicable support documents

The following sections of Chapter 1 of this document summarize available data relevant to the Yucca Mountain stratigraphy and structure, and identify areas of insufficient or inconclusive information:

<u>SCP section</u>	<u>Subject</u>
1.2.2.2	Cenozoic rocks (stratigraphy and lithology at Yucca Mountain)
1.3.2.2.2	Structures and structural history of Yucca Mountain
1.8.1.2	Stratigraphy and lithology
1.8.1.3	Structural geology and tectonics
1.8.2.1	Relation of geology to repository design

Parameters

Table 8.3.1.4-1 summarizes the geologic characteristics that will be measured or calculated as a result of the studies planned for this investigation. The geologic characteristics provided through this program will be used in developing the hydrogeologic stratigraphy in Section 8.3.1.2, and the geochemical stratigraphy in Section 8.3.1.3. The geologic characteristics

CONSULTATION DRAFT

will also be combined with the data developed in Investigations 8.3.1.15.1 and 8.3.1.15.2 and in Characterization Programs 8.3.1.2 and 8.3.1.3 to develop three-dimensional models of thermal, mechanical, hydrologic, and geochemical properties in Study 8.3.1.4.1.3.

Purpose and objectives of the investigation

The objectives of this investigation are three-fold and, in general, cover those studies and activities that will allow an understanding of the large-scale variation in stratigraphy and structure in support of design and performance assessment calculations. First, this investigation will provide primary data on the lateral and vertical variations in site stratigraphy through acquisition of borehole cores and cuttings and surface geologic mapping. Second, it will provide information that will allow three-dimensional modeling (through the use of borehole and surface geophysical surveys) of the variation in properties of interest between points of primary data. Lastly, it will provide information on the lateral and vertical variation of structural elements that may affect in situ properties of interest (e.g., fracture-related flow) in conjunction with site characterization investigations on geohydrology, geochemistry, postclosure tectonics, and seismicity (i.e., preclosure tectonics) (Sections 8.3.1.2, 8.3.1.3, 8.3.1.8, and 8.3.1.17).

Technical rationale for the investigation

Development of a comprehensive, three-dimensional description of geologic and geophysical characteristics of the site requires integration of information from subsurface investigations, geologic mapping, surface-based and subsurface geophysical surveys, and geologic studies in the exploratory shaft and underground drifts. This model provides the geologic constraints for developing quantitative three-dimensional models of rock properties in Investigation 8.3.1.4.3. Such a model must be compatible with the stratigraphic, structural, and tectonic setting of the region, and must incorporate genetic models that address depositional, thermal, and alteration histories of local volcanic rock units, part of which are developed under Characterization Program 8.3.1.8.

On the basis of structural considerations, the areal extent of geologic investigations at Yucca Mountain can be divided into two areas, repository perimeter drift and site, as defined below (Figure 8.3.1.4-3). The perimeter drift defines an area where a significantly lower concentration of faults has been mapped relative to surrounding areas. This area is bounded on the north and northeast by Drill Hole Wash. The Solitario Canyon fault zone marks its western border, and a belt of small-scale structural features north of Abandoned Wash limits its eastern and southeastern extents. The site area boundary is located outward approximately 4 to 6 km from the boundaries of the perimeter drift. The northern, eastern, and southern limits of the region of investigation around the site are selected primarily on the basis of differences in structural styles inferred from existing geologic and geophysical data. They include Prow Pass (Claim Canyon Caldron), Fortymile Wash, and a northeast-trending lateral fault south of Busted Butte. The western boundary of the study region has been selected at the Windy Wash fault zone on the basis of maintaining a similar amount of lateral distance from the perimeter drift.

CONSULTATION DRAFT

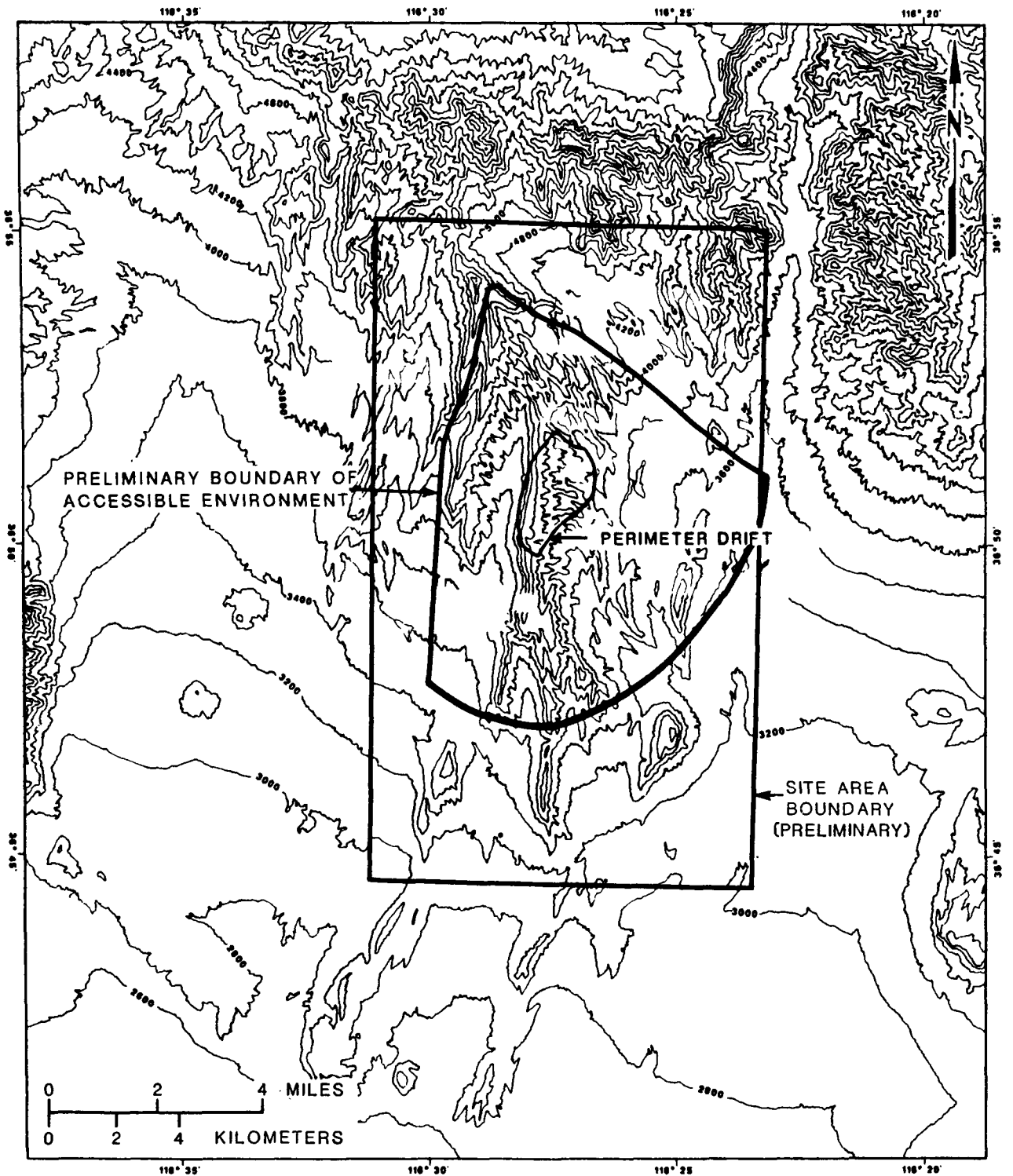

Figure 8.3.1.4-3. Areas of geologic investigation at Yucca Mountain.

CONSULTATION DRAFT

The area of investigation will include a larger area than the site as the understanding of the characteristics of each lithostratigraphic unit on a regional scale will allow a higher level of confidence when using deterministic information to interpolate between drillholes, shafts, and surface exposures within the site area.

The site geologic investigations can be divided into three principal investigations: (1) development of an integrated drilling program (8.3.1.4.1), (2) geologic framework of the Yucca Mountain site (this investigation), and (3) development of three-dimensional models of rock characteristics at the repository site (8.3.1.4.3). The area of investigation will include a larger area than the site as the understanding of the characteristics of each lithostratigraphic unit on a regional scale will allow a higher level of confidence when using deterministic information to interpolate between drillholes, shafts, and surface exposures within the site area. Integration of these investigations requires continual correlation at all levels from data collection to analysis and interpretation. These investigations will provide geologic, geomechanical, geothermal, geohydrologic, and geochemical information for the data base needed by the performance and design issues (Table 8.3.1.4-1).

Geophysical surveys may play a major role in providing information on the gross spatial distribution of bulk properties. They also will be used at particular drillholes to interpolate between depth intervals from which cores or other samples were acquired. Geophysical surveys will be evaluated, and if proven effective, will be used to detect possible rock property contrasts between drillholes. Surveys not proven to be effective will be eliminated from the investigations program. The results of direct in situ measurements made from drillholes and from the exploratory shaft facility, will be used to analyze data from methods such as seismic or electrical tomography to develop quantitative and empirical relationships needed to characterize subsurface variability between shafts and drillholes. A fundamental element of stratigraphic studies is the development of a data base of rock sample analyses collected from holes drilled for geologic and hydrologic purposes. Continuously cored geologic drillholes will continue to be used to establish the reference stratigraphic framework to currently planned depths of 1,828 m from which comparative studies between geophysical and geologic characteristics can be made. Geophysical relationships that are established in core studies can then be applied to the stratigraphic study of rotary drillholes (where rock samples are limited to drill bit-cuttings and sidewall samples) and to the geologic interpretation of data derived from surface-based and subsurface geophysical surveys. With the incorporation of additional stratigraphic data collected from surface field studies, a more complete stratigraphic data base will be used to map the distribution of intrinsic lithologic characteristics within Yucca Mountain. Primary geologic parameters that influence the distribution of rock properties include chemical composition, degree of welding, primary crystallization, and type and degree of alteration. Surface and subsurface mapping of lithologic characteristics within stratigraphic units aids in interpreting the transportation, emplacement, cooling, and alteration histories of major ash-flow tuff sheets. In turn, these interpretations will aid in the prediction of physical properties in parts of the repository block where relatively few subsurface samples will be collected. Stratigraphic investigations are grouped under Study 8.3.1.4.2.1.

CONSULTATION DRAFT

Characterization of the structural setting of the site requires detailed study of local fault and fracture systems and their relation to the local and regional stratigraphic, tectonic, and geophysical framework. Recognition of small-scale structures within and near the site area is achieved through detailed mapping of zonal features of exposed ash-flow tuffs and interpretation of detailed surface and subsurface geophysical surveys. An understanding of the fracture network at the site requires the application of innovative approaches because the fracture system (1) is poorly exposed at the surface, (2) is predominantly composed of steeply dipping (high-angle) fractures, (3) includes fractures induced by both tectonic and cooling processes, and (4) includes strata-bound subsystems. Lateral components of the system are studied principally by mapping and analyzing surface exposures. Characterization of the vertical component of the fracture system will largely be achieved through detailed study of the exploratory shaft and drifts, and to a lesser degree, by examination of drillhole walls and core samples. In addition, borehole geophysics, particularly surface-to-borehole seismic profiling, cross-hole seismic surveys, and borehole-to-surface electrical resistivity methods may provide information regarding bulk distribution of fractures. Structural investigations are grouped under Study 8.3.1.4.2.2.

Stratigraphic and structural information will be used in Investigation 8.3.1.4.3, to constrain the interpretation of: thermal and mechanical properties (Investigation 8.3.1.15.1), the in situ thermal and stress conditions (Investigation 8.3.1.15.2), geohydrologic properties (Investigations 8.3.1.2.1 and 8.3.1.2.2), and geochemical properties (Investigation 8.3.1.3.2). The final product (Study 8.3.1.4.3.2) is a three-dimensional model of rock characteristics of Yucca Mountain, which will be used in designing the underground facility and assessing performance.

8.3.1.4.2.1 Study: Characterization of the vertical and lateral distribution of stratigraphic units within the site area

The objective of this study is to determine the vertical and lateral variability and emplacement history of stratigraphic units and lithostratigraphic subunits within the Yucca Mountain site area.

Geologic mapping, geophysical surveys, borehole evaluations, and geologic sampling, testing, and analysis will be used to gather pertinent geologic data, develop lithologic correlations, and describe the geologic stratigraphy of the site area. Surface-based mapping and borehole activities will be complemented by geologic mapping and testing in the exploratory shaft and drifts (Activity 8.3.1.4.2.2.4).

Activities planned for this study include (1) surface and subsurface stratigraphic studies of the host rock and surrounding units, (2) surface-based geophysical surveys, (3) borehole geophysical surveys, (4) petrophysical properties testing, and (5) correlation of stratigraphy and rock magnetic properties.

CONSULTATION DRAFT

8.3.1.4.2.1.1 Activity: Surface and subsurface stratigraphic studies of the host rock and surrounding units

Objectives

The objective of this activity is to determine the spatial distribution, history, and characteristics of stratigraphic units within the Paintbrush Tuff, tuffaceous beds of Calico Hills, Crater Flat Tuff, and possibly older volcanic rocks within the site area.

Parameters

The characterization parameters for this activity are

1. Welding and primary crystallization characteristics of lavas and ash-flow tuffs.
2. Petrographic characteristics.
3. Pumice characteristics.
4. Type and abundance of lithic fragments.
5. Characteristics of lithophysal zones.
6. Degree and type of alteration.
7. Depth, thickness, attitude, and extent of lithostratigraphic units.
8. Location and general characteristics of bedded tuff intervals, including grain size and sorting characteristics, diagenetic mineral phases, and depositional characteristics.

Description

Characterization of the stratigraphic sequence within the site area will use (1) borehole drilling and coring, (2) sampling, lithologic examination, and analysis of drill-bit cuttings and core, (3) borehole video surveys and logging, (4) surface-outcrop mapping; (5) petrographic and geochemical analysis of drillcore, cuttings, and outcrop samples, and (6) surface and borehole geophysical surveys.

Geologic and geophysical data derived from existing holes and additional holes will provide information to aid in the development of three-dimensional rock characteristics models of the proposed repository area.

Pending the integration of the drilling program, three additional continuously cored holes may be drilled (Figure 8.3.1.4-4) in the vicinity of the site to better explain inferred geologic and geophysical anomalies and to help determine the lithologic variability in the Paintbrush Tuff, tuffaceous beds of Calico Hills, and Crater Flat Tuff. One hole (USW G-5) would be located along the northeast flank of Yucca Mountain, to determine if abrupt changes in lithologies of underlying units or changes in structural style within Yucca Wash are factors that influence the steeper gradient in the

CONSULTATION DRAFT

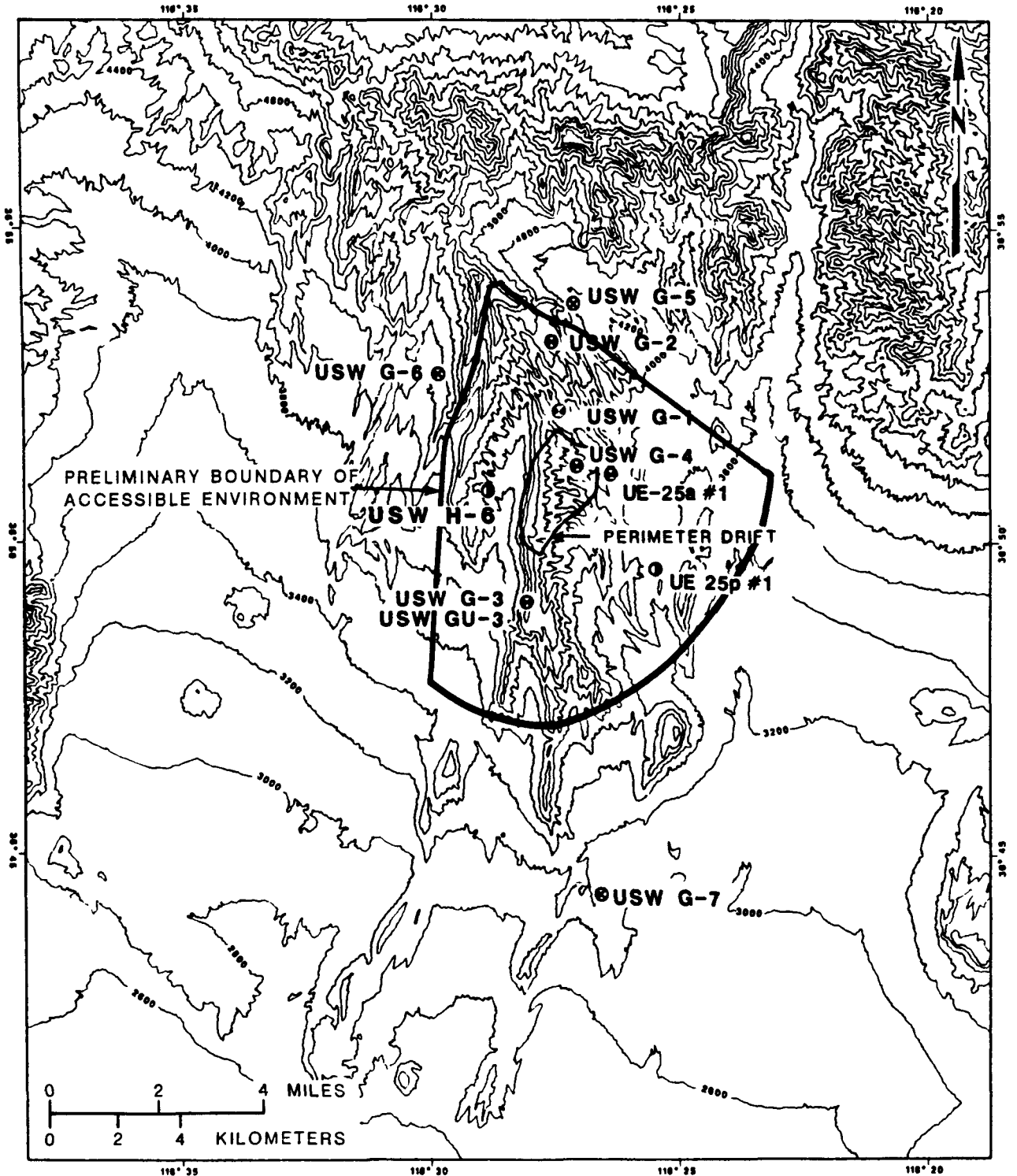

- EXPLANATION**
- Continuously cored hole
 - Proposed continuously cored hole
 - Intermittently cored hole

Figure 8.3.1.4-4. Locations of existing and proposed continuously cored holes at Yucca Mountain

CONSULTATION DRAFT

potentiometric surface north of drillhole USW G-1. Another hole (USW G-6) is planned along the northwest flank of Yucca Mountain in the vicinity of Windy Wash. This hole is expected to provide representative stratigraphic data for this area and allow correlation of thicknesses of key stratigraphic units across the site area. A third hole (USW G-7) may be located about 5 km southwest of Busted Butte in the southern part of Yucca Mountain. Within this area the Paintbrush Tuff is extremely thin and appears to onlap an inferred high point in the preexisting topography. This hole will be used to determine the nature of this feature and its effect on ground-water travel times and potential flow paths in southern Yucca Mountain for saturated zone flow modeling (Section 8.3.1.2.3.4). These holes will allow interpolation of lithologic characteristics between the repository area where more densely spaced holes may be drilled (Investigations 8.3.1.4.1 and 8.3.1.4.3) and the preliminary boundary of the accessible environment.

Studies of the hydrology of the unsaturated and saturated zones include plans for borehole drilling and coring (Section 8.3.1.2). The total suite of holes drilled by the DOE will provide an opportunity to study the lateral variability of the Topopah Spring Member, other members of the Paintbrush Tuff, tuffaceous beds of the Calico Hills, Crater Flat Tuff, and other units, and will provide samples for geologic evaluation.

Excavation of the exploratory shaft and drifts, and vertical and lateral boreholes drilled from the underground openings will provide additional opportunity to sample and perform geophysical measurements for characterizing the lithostratigraphic subunits between the ground surface and the upper part of the tuffaceous beds of the Calico Hills. The distribution of lithophysal zones within the Topopah Spring Member will be mapped in the exploratory shaft facility.

Bedded tuffs that divide major ash-flow tuffs commonly range in thickness from less than 1 m to about 61 m (Table 8.3.1.4-3) and include a variety of lithologies that range from fine-grained tuffaceous sandstone to verycoarse ash-fall tuff. Core recovery is typically poor in the unsaturated zone; consequently nearby outcrops will be sampled in the northern part of Yucca Mountain to fill gaps in the data. This study will aid in identifying stratigraphic lateral continuity and inhomogeneities that may act as potential lateral flow paths.

Video camera surveys will be performed in all holes drilled in the vicinity of Yucca Mountain. The textural and tonal contrasts that are seen on camera logs will provide valuable information about key stratigraphic features such as the vertical distribution of lithophysal cavities, thin-reworked and ash-fall tuff intervals, non- to partially welded zones, lithic-rich zones, spherulitic zones, glassy intervals, relative degree of sorting, relative sizes of pumice clasts, and nature of contacts between units. Video-camera observations will be correlated with core, drill bit-cuttings, and geophysical logs to interpret the subsurface characteristics of rock units.

The ability to predict lateral variability of the Paintbrush Tuff, tuffaceous beds of the Calico Hills, and Crater Flat Tuff beyond the perimeter drift can be enhanced by conducting a study of outcrops in highlands surrounding the site area. Stratigraphic sections of sufficient thickness will

CONSULTATION DRAFT

Table 8.3.1.4-3. Volcanic stratigraphy at Yucca Mountain

Potassium- argon dating method age (million years)	Magnetic _b polarity	Rock unit ^a	Range in thickness (m)
10.2		Basalt dikes	
		* Timber Mountain Tuff	
11.3		* Rainier Mesa Member	0-46
		Bedded tuff	0-61
		* Paintbrush Tuff	
12.5	R	* Tiva Canyon Member	69-148
		Bedded tuff	1-15
	R	* Yucca Mountain Member	0-29
		Bedded tuff	0-47
	R	* Pah Canyon Member	0-71
		Bedded tuff	0-9
13.1	N	* Topopah Spring Member	287-359
		Bedded tuff	1-17
13.4 ^c		Tuffaceous beds of Calico Hills	27-289
		Bedded tuff	0-21
		* Crater Flat Tuff	
	N	* Prow Pass Member	80-193
		Bedded tuff	2-10
13.5	N	* Bullfrog Member	68-187
		Bedded tuff	6-22
	R	* Tram Member	190-369
		Bedded tuff	3-50
	N	Dacite lava and flow breccia	0-249
		Bedded tuff	0-14
	I	* Lithic Ridge Tuff	
		Bedded tuff	3-7
13.9		Older volcanic rocks and volcanogenic sedimentary rocks	345+

^aNames and rankings of some units do not conform to U.S. Geological Survey usage. Formally recognized names are preceded by asterisks.

^bPolarity symbols: R = reversed, N = normal polarity, I = intermediate between reversed and normal.

^cAge determined from associated lava flow.

CONSULTATION DRAFT

be described and measured principally within the southwest quadrant of the NTS and in Crater Flat. Areas of particular interest will include northern Crater Flat, Calico Hills, Fortymile Canyon, Little Skull Mountain, Skull Mountain, and the northernmost part of Yucca Mountain. Efforts will focus on identifying and correlating lateral variations of subunits of the Topopah Spring Member (Figure 8.3.1.4-5). Additional thickness data also will be collected for the Yucca Mountain and Pah Canyon members, tuffaceous beds of Calico Hills, and Prow Pass and Bullfrog members (Figure 8.3.1.4-6).

Rock samples will be examined megascopically as well as with hand lens and binocular microscope. Samples of particular interest will be selected for further petrographic, mineralogical, and isotopic analyses. Samples also will be selected for detailed petrographic and geochemical analyses (see activities described in the geochemistry program (Section 8.3.1.3)). Megascopic descriptions, coupled with analyses of selected thin sections and grain mounts, will focus on identifying distinctive lithologies, key marker beds, and correlatable sequences. Scanning electron microscopy (SEM) will be used to identify distinctive morphologies and interpret modes and environments of deposition. X-ray powder diffraction and microprobe analyses on selected samples will be used to identify relative abundance of mineral phases.

On the basis of the mineralogical studies of core from Yucca Mountain, about 100 intervals (samples) of mordenite-bearing or suspected mordenite-bearing core from drillholes USW G-1, USW G-2, USW G-4, and UE-25 b#1h will be selected for additional studies. All samples will be from the Crater Flat Tuff, tuffaceous beds of Calico Hills, and the lower part of the Paintbrush Tuff. The mineralogy of each sample will be determined by X-ray powder diffraction. Results of these determinations will provide the abundance of mordenite in each sample and will be the basis for further selecting of certain samples for additional investigation by optical microscopy of these sections and grain mounts, SEM, and electron microprobe analysis. Studies by optical microscopy and SEM will provide information on the morphology of the mordenite, on the paragenetic relationships of mordenite with diagenetic clinoptilolite, and analcime. However, paragenetic relationships are poorly understood. Electron microprobe analyses of mordenite and associated diagenetic minerals will provide the chemical composition and suggest those chemical conditions that favored the growth of mordenite. Attempts will be made to prepare pure mordenite separates from mordenite-rich samples by size fractionation and heavy liquid separation. Chemical analyses by X-ray fluorescence and unit-cell parameters by X-ray powder diffraction will be obtained for the pure mordenite separates. In addition, unit-cell parameters by X-ray powder diffraction will be obtained for other suitable mordenites and then examined with respect to the zeolite composition, paragenetic sequences, host stratigraphic unit, and geographic location.

Data obtained from geologic mapping, borehole drilling, coring, video surveys, sampling and petrographic analysis and geophysical studies will be compiled into stratigraphic and lithologic models. This information will be used with geophysical data (Activities 8.3.1.4.2.1.2 and 8.3.1.4.2.1.3 petrophysical data (Activity 8.3.1.4.2.1.4), rock magnetic properties (Activity 8.3.1.4.2.1.5), and data from investigation of tectonics and igneous processes (Programs 8.3.1.8 and 8.3.1.17) to formulate the site geologic model in Study 8.3.1.4.2.3. These models will provide the geologic

CONSULTATION DRAFT

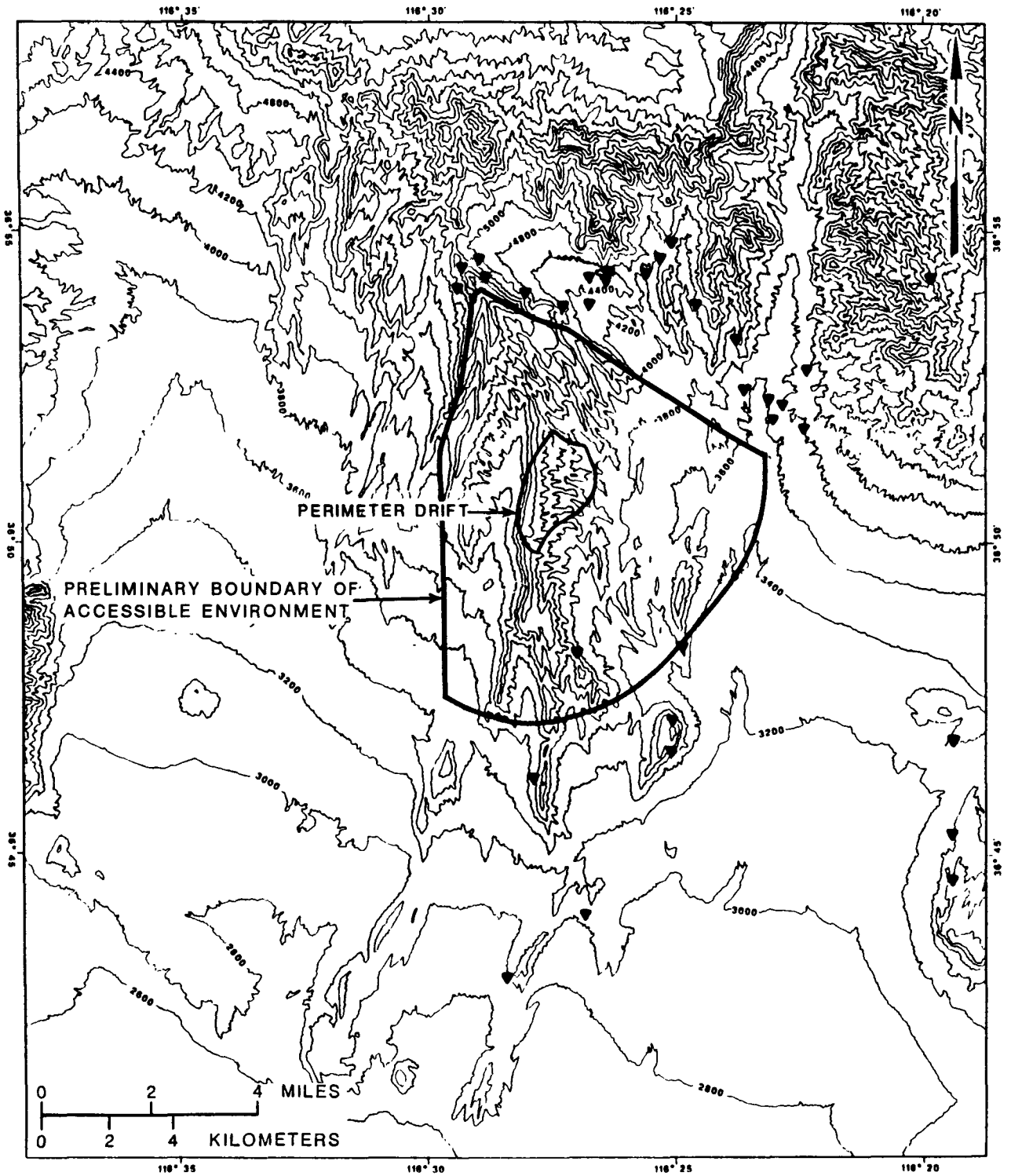

Figure 8.3.1.4-5. Approximate locations of additional surface stratigraphic studies of the Topopah Spring Member of the Paintbrush Tuff.

CONSULTATION DRAFT

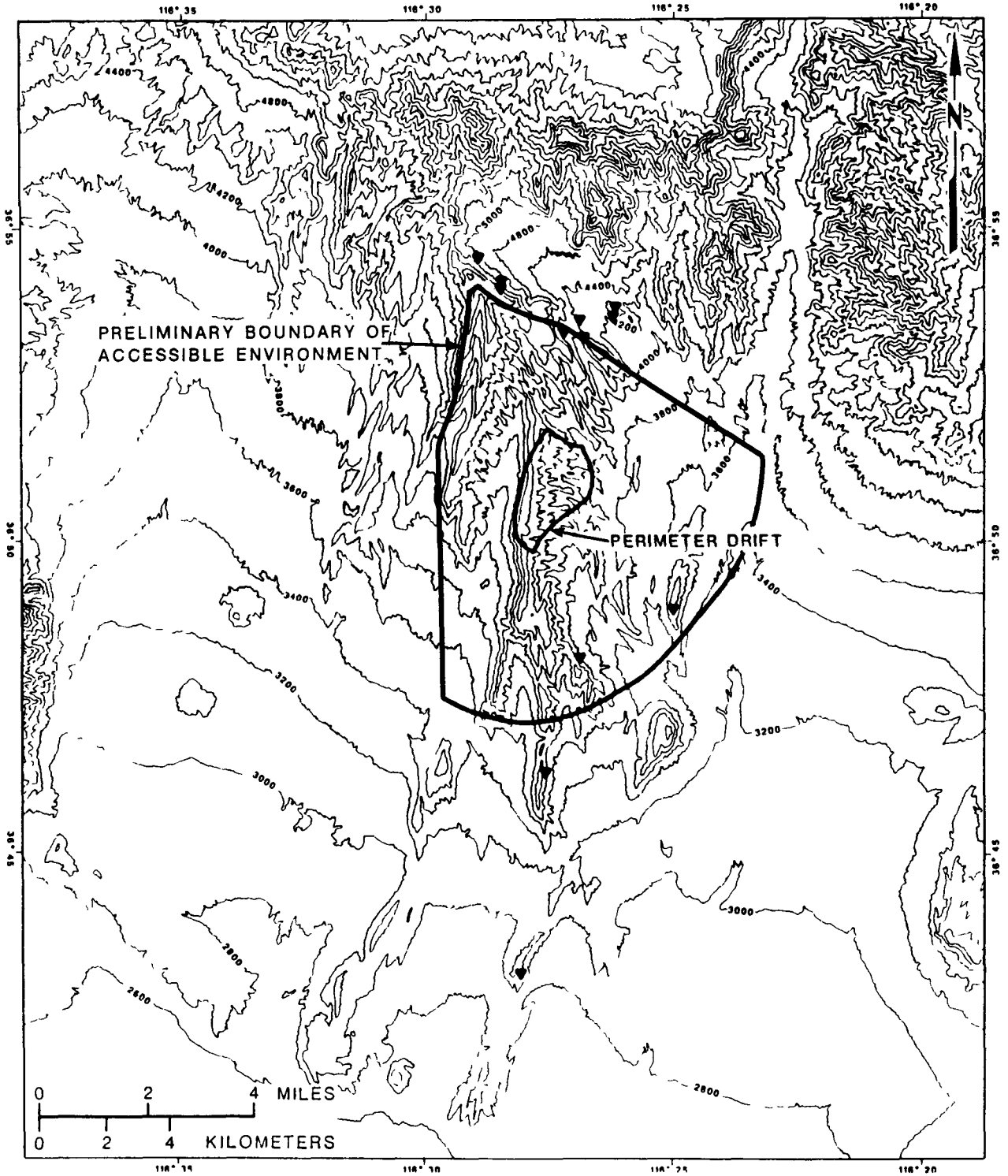

Figure 8.3.1.4-6. Approximate locations of additional surface stratigraphic studies of the Yucca Mountain and Pah Canyons Members of the Paintbrush Tuff, tuffaceous beds of the Calico Hills, and Prow Pass and Bullfrog Members of Crater Flat Tuff

CONSULTATION DRAFT

framework for use in the development of models of the vertical and lateral variability of subsurface rock properties.

Methods and technical procedures

The methods and technical procedures for Activity 8.3.1.4.2.1.1 are given in the following table.

Method	Technical procedure		Date
	Number	Title	
(NWM-USGS-)			
Borehole drilling and coring	TBD ^a	NNWSI Project borehole drilling and coring procedures	TBD
Sampling, lithologic examination, and analysis of drill bit-cuttings and core	TBD	NNWSI Project sampling and lithologic examination procedures for drill-bit cuttings and core samples	TBD
	GP-19, RO	Procedure for the identification, handling, and disposition of drillhole core and cutting samples from the drill site to the core library	6 Mar 87
(NWM-USGS-)			
	GP-02, RO	Subsurface investigations	1 Mar 83
	GP-05, RO	Geologic support activities	1 Mar 83
	GP-18, RO	Volcanic stratigraphic studies	24 Sep 86
	GP-20	Volumetric estimation of lithophysae	TBD
Borehole video surveys and logging	GP-02, RO	Subsurface investigations	1 Mar 83
	GP-10, RO	Borehole video fracture logging	12 Apr 85

CONSULTATION DRAFT

Method	Technical procedure		
	Number	Title	Date
Surface-outcrop mapping of exposures of the Paintbrush Tuff, tuffaceous beds of the Calico Hills, and Crater Flat Tuff units	GP-01, RO	Geologic mapping	1 Mar 83
	GP-05, RO	Geologic support activities	1 Mar 83
	GP-18, RO	Volcanic stratigraphic studies	24 Sep 86
Isotopic and geochemical studies	GP-18, RO	Volcanic stratigraphic studies	24 Sept 86
	GCP-01, RO	Radiometric-age data base	15 June 81
	GCP-02, R1	Labeling, identification and control of samples for geochemistry and isotope geology	20 Jan 87
	GCP-05, RO	Radium, equivalent uranium, thorium, and potassium analysis by gamma-ray spectrometry	15 June 81
	GCP-07, RO	Geochemical mineral separation	15 June 81

^aTBD = to be determined.

8.3.1.4.2.1.2 Activity: Surface-based geophysical surveys

Objectives

The objective of this activity is to improve confidence in stratigraphic models of Yucca Mountain by incorporating geophysical constraints.

Parameters

The parameters of this activity are

1. Seismic velocity contrasts, seismic attenuation, seismically reflective horizons, density variation, local variations in magnetic field orientation and strength, and variations in electrical properties which are associated with vertical or lateral changes in lithology.
2. Lateral continuity of horizons defined by geophysical surveys.

CONSULTATION DRAFT

Description

Surface-based geophysical surveys will be used to help define the lateral and vertical distribution of the stratigraphic units and litho-stratigraphic subunits of the Yucca Mountain tuffs. Table 8.3.1.4-4 summarizes the geophysical techniques that will be used to study the vertical and lateral continuity of rock units. The table provides information on the location and scope of the survey and is divided into two parts. The first part describes geophysical surveys to be used by Characterization Program 8.3.1.4, and the second part identifies geophysical surveys that are used primarily for Characterization Program 8.3.1.17 (preclosure tectonics) and Characterization Program 8.3.1.8 (postclosure tectonics) but will be used to develop the geologic model. Geophysical surveys will also aid in determining favorable sites for drillholes. These detailed geophysical surveys will include (1) seismic refraction, (2) seismic reflection by the Mini-sosie technique (Barbier, 1983), (3) gravity and magnetics, and (4) electromagnetic soundings.

A seismic refraction profile will be acquired in the Yucca Wash area (Figure 8.3.1.4-7). This profile will be used to investigate significant velocity contrasts in the volcanic section that are associated with abrupt lateral changes in lithology, and that may be the result of structural displacement or alteration associated with a steep gradient in the potentiometric surface north of drillhole USW G-1 and in the vicinity of proposed corehole USW G-5.

After proof-of-technique trials, as many as 15 seismic reflection profiles may be performed using a shallow penetrating, high-resolution method called Mini-sosie (Barbier, 1983). This technique will be used to study the position of marker-horizons that have a sufficient contrast in seismic velocity and is expected to be useful to a maximum depth of about 1,000 m. Of specific interest are possible marker horizons that may be buried beneath Yucca Wash and Midway Valley (Figure 8.3.1.4-8). Information collected will also be used to trace individual faults by studying the lateral continuity of reflecting horizons. This technique differs from previous reflection studies because it is designed to penetrate only the upper geologic section.

Two detailed ground magnetic and gravity surveys will be performed across Yucca Wash (near USW G-5) and south of Busted Butte (near USW G-7) (Figure 8.3.1.4-9) in association with proposed geologic coreholes USW G-5, G-6, and G-7. In situ magnetic and density variations will be used to map the local vertical and lateral distribution of lithostratigraphic units.

A number of geophysical surveys that will be performed for tectonics Investigation 8.3.1.17.4 will also provide information for evaluation of stratigraphy and structure. These surveys and methods are indicated in the second part of Table 8.3.1.4-4. Many of these methods have not been tried at the Yucca Mountain site and will be tested before application for data collection purposes.

Shallow seismic refraction and shear wave refraction and reflection, will be used for investigation of faults in the vicinity of Yucca Mountain, using sledgehammer and shear wave sources. The number and location of the traverses will be based on the results of detailed geologic mapping. These

Table 8.3.1.4-4. Summary of geophysical studies for Program 8.3.1.4 (rock characteristics)
(page 1 of 9)

Method	SCP section	Location	Scope	Decision points	Comments
ACTIVITIES DESCRIBED IN STUDIES 8.3.1.4.2.1 AND 8.3.1.4.2.2					
<u>Seismology</u>					
Vertical seismic profiling	8.3.1.4.2.2.6	Repository block and vicinity	15 to 25 geotomographic profiles, 0.2 to 2 km in length, cross-hole and surface-down-hole surveys. Directional shear and compression energy sources	Decision to Proceed (DTP) after feasibility test DTP after calibration in shaft and drifts	Used to map 3-dimensional network of rock mass fractures. 20-m per pixel geometry.
<u>Paleomagnetism</u>					
Site	8.3.1.4.2.1.5	Yucca Mountain	Orient drill core as it becomes available. Establish reference orientation through study of outcrop samples. Determine magnetic character of outcrop samples to aid in interpretation of aeromagnetic data	None	See Rosenbaum (1983), Rosenbaum and Rivers (1984), Rosenbaum and Snyder (1985), Rosenbaum (1985)
<u>Borehole geophysical methods</u>					
<u>Geophysical logging</u>					
Borehole gravimetry	8.3.1.4.2.1.3	Yucca Mountain	15 water-table (WT) drillholes, existing deep holes that can be made available, and all new holes that reach the base of the Topopah Spring Member (Tpt)	None	Already have data in H-1, P 1, C 1, G-3, and G-4. Data will be used to model structure in the immediate vicinity of each borehole, to study lithophysical zones, and to model the Paleozoic surface beneath Yucca Mountain. See Robbins et al. (1982), Healy et al. (1984), and Healey et al. (1986)

Table 8.3.1.4-4. Summary of geophysical studies for Program 8.3.1.4 (rock characteristics)
(page 2 of 9)

Method	SCP section	Location	Scope	Decision points	Comments
Borehole magnetic logs	8.3.1.4.2.1.3	Yucca Mountain	15 WT drillholes, and new drillholes before casing operations	None	Used to determine map-pable magnetic events for studying structural integrity of Yucca Mountain, and to supplement paleomagnetic and lithophysical studies. See Hagstrum et al. (1980).
Induced potential logs	8.3.1.4.2.1.3	Yucca Mountain	Test in one or two drillholes	Evaluate for effectiveness after 1 or 2 drillholes	Feasibility study to determine if the method can be used to map zeolitized rock
Commercially available logs	8.3.1.4.2.1.3	Yucca Mountain	All existing unlogged drillholes, all new holes, and relog selected holes	None	To obtain parameters for hydrologic, geologic, and geophysical models, and to determine uniformity and lateral distribution of rock properties within the stratigraphic units. See Spengler et al. (1979), Maldonado et al. (1979), Daniels and Scott (1981), Hagstrum et al. (1980), Daniels et al. (1981), Muller (1982), Muller and Kibler (1983 and 1984), Spengler and Chornack (1984), Muller (1985), and Muller and Kibler (1985)
Borehole radar logs	8.3.1.4.2.2.3	Yucca Mountain	Drillholes that penetrate the base of the Topopah Spring Member	Evaluate for effectiveness after 1 or 2 drillholes	Primarily used for fracture detection or to demonstrate the absence of fractures in the unsaturated zone

8.3.1.4-48

CONSULTATION DRAFT

Table 8.3.1.4-4. Summary of geophysical studies for Program 8.3.1.4 (rock characteristics)
(page 3 of 9)

Method	SCP section	Location	Scope	Decision points	Comments
Acoustic televiewer logs and TV camera logs	8.3.1.4.2.2.3	Yucca Mountain	All Yucca Mountain drillholes	None	For fracture and fault zone detection, and stratigraphic and lithologic correlation. See Healy et al. (1984), Stock et al. (1984), Stock and Healy (1984), Stock et al. (1985)
Large spacing EM and resistivity logs	8.3.1.4.2.1.3	Yucca Mountain	Selected drillholes	After evaluation of surface and borehole data	To determine accurate large-volume in situ values for studying fracture and lithophysical zones, and for interpreting anomalies detected with surface and borehole data
Borehole to surface methods					
Resistivity and EM methods	8.3.1.4.2.1.3, 8.3.1.4.2.2.3	Yucca Mountain	Selected drillholes	After evaluation of surface and borehole data	For fracture studies in the unsaturated zone, to obtain detailed structure in areas of anomalous surface geophysical data and in critical locations such as the shaft site and surface facilities locations, and to verify projected faults at critical locations. See Daniels and Scott (1981)
High resolution P and S wave seismic	8.3.1.4.2.2.3	Yucca Mountain	Selected drillholes	After evaluation of surface and borehole surveys	Same as previous, and to obtain parameters for designing effective, deeper-penetrating seismic surveys

8.3.1.4-49

CONSULTATION DRAFT

Table 8.3.1.4-4. Summary of geophysical studies for Program 8.3.1.4 (rock characteristics)
(page 4 of 9)

Method	SCP section	Location	Scope	Decision points	Comments
Surface to hole seismic refraction	8.3.1.4.2.2.3	Yucca Mountain	Selected drillholes	After evaluation of surface and borehole surveys	Same as two previous, and for critical fault location and bed tracing
Borehole to borehole methods	8.3.1.4.2.2.3	Yucca Mountain close-spaced holes for hydrologic testing and for surface facilities studies	Selected drillholes	None	Geotomography to map fractures and demonstrate mappability of features that intersect the drillholes using resistivity, EM, radar, and high resolution P and S seismic (Yo Yo) methods
Petrophysics	8.3.1.4.2.1.4	Yucca Mountain	Selected core from cored drillholes	None	To verify geophysical log accuracy, calibrate computed logs, determine properties that are not or cannot be measured in situ, and to model and interpret surface geophysical studies

SUMMARY OF GEOPHYSICAL STUDIES FROM OTHER INVESTIGATIONS CONTRIBUTING TO SITE GEOLOGY STUDIES 8.3.1.4.1.2 AND 8.3.1.4.2.2

Seismology

Deep refraction	8.3.1.17.4.3.1	E-W transect, Indian Spring-Stovepipe Wells (Figure 8.3.1.-17-12)	Reversed profiles and cross-profiles, shot-points 8- to 20-km spacing	None	Existing surveys shown in Figure 8.3.1.17-13. See Pankratz (1982), Mooney et al. (1982), Hoffman and Mooney (1983), Hoover et al. (1982), Monfort and Evans (1982), and Sutton (1984)
-----------------	----------------	---	---	------	---

Table 8.3.1.4-4. Summary of geophysical studies for Program 8.3.1.4 (rock characteristics)
(page 5 of 9)

Method	SCP section	Location	Scope	Decision points	Comments
Shallow (Bison) refraction and shear wave refraction and reflection	8.3.1.17.4.5.1 and others	Quaternary faults, Yucca Mountain and vicinity	250-500 m traverses, portable instruments, sledgehammer energy source. Shear wave method uses 12 (or more) geophones, 3-m spacing	Number and location to be decided on the basis of geologic mapping	Maximum depth of penetration 100 m. Used to detect offset in surficial deposits. Shear wave method capable of detecting 30 cm offset
Evaluation of proposed deep reflection survey	8.3.1.17.4.3.1	Proposed survey 15 km test located to the south of Amargosa Valley or southwest of Beatty	To be determined	DTP after evaluation of preliminary tests (15 km recon. line) and peer review	COCORP survey extending northward into southern Death Valley produced marginal quality data, although data in the upper one second are locally good. Five- and ten-second reflections were imaged with fair continuity. See de Voogd et al. (1986).
Intermediate reflection and intermediate refraction	8.3.1.17.4.7.1	Controlled area, Yucca Mountain	Evaluate previous results, assess potential for application of this method to Yucca Mountain, plan new application if appropriate	None	This is a planning activity only. Previous reflection survey using Vibroseis at Yucca Mountain failed (McGovern, 1983). More recent surveys using air gun at Mid Valley produced useful results (McArthur and Burkhard, 1986). See also Hoover et al. (1982).
Shallow (Mini-sosie) reflection	8.3.1.17.4.7.8 and others	Crater Flat, Jackass Flats (Figure 8.3.1.-17-8)	7 to 15 profiles, 1 to 5 km in length, hand carried instruments. Energy from battery of hand-operated tampers	DTP after evaluation of two preliminary profiles selected from profiles indicated in Figure 8.3.1.4 8	Maximum depth of penetration 1 km. Used to map shallow structural and stratigraphic features. Additional Mini-sosie surveys at Yucca Mountain are planned in Activity 8.3.1.4.2.1.1

Table 8.3.1.4-4. Summary of geophysical studies for Program 8.3.1.4 (rock characteristics)
(page 6 of 9)

Method	SCP section	Location	Scope	Decision points	Comments
<u>Gravity investigations</u>					
Regional maps	8.3.1.17.4.11.1	Yucca Mountain and vicinity	Beatty 1:100,000 quad, Pahute Mesa 1:100,000 quad, NTS 1:100,000 map area, Yucca Mountain, 1:48,000 map area	None	Field work complete, compilation complete, final results not yet available. See Snyder and Oliver (1981), Ponce (1981), Ponce and Oliver (1981), Hoover et al. (1982), Ponce and Hanna (1982), Jasma et al. (1982), Ponce (1984), and Snyder and Carr (1984).
Site area map	8.3.1.17.4.2	Yucca Mountain	1:24,000 map of site and vicinity, 200 ft spacing of stations along E-W lines spaced 500 ft apart (where topography permits)	None	Will require as many as 7,500 additional stations. Useful for establishing stratigraphic variability of repository host rock and fault location and offset. See Snyder (1981), Snyder and Carr (1982), Jansma et al. (1982), Kane et al. (1981), Ponce et al. (1985)
Detailed surveys, deep reflection profiles and shallow reflection profiles	8.3.1.17.4.3.1	Stovepipe Wells, Yucca Mountain, Indian Springs. Precise location to be determined.	Gravity determinations along profiles at 500 ft (150 m) spacing	DTP only if seismic surveys run	Assists interpretation of seismic results
<u>Magnetic methods</u>					
Regional aeromagnetic maps	8.3.1.17.4.11.1	Yucca Mountain and vicinity	Beatty, Pahute Mesa, Indian Springs, and Pahrangat 1:100,000 quadrangles to be	None	Field investigations complete; compilation 80% (?) complete. See Kane et al. (1981), Hoover

8.3.1.4-52

CONSULTATION DRAFT

Table 8.3.1.4-4. Summary of geophysical studies for Program 8.3.1.4 (rock characteristics)
(page 7 of 9)

Method	SCP section	Location	Scope	Decision points	Comments
Regional aeromagnetic maps (continued)			compiled from existing surveys		et al. (1982), Kane and Bracken (1983), U.S. Geological Survey (1984), Ponce (1984)
Site aeromagnetic maps	8.3.1.17.4.7.3	Yucca Mountain	1:12,000 scale map of site and vicinity, continuous aeromagnetic survey along E-W flight lines spaced 1/16 mile (0.1 km)	None	1:62,500 scale map complete (U.S. Geological Survey, 1984). See also Jansma et al. (1982), Bath et al. (1982), Kane et al. (1982), Kane and Bracken (1983), and Bath and Jahren (1984)
Ground magnetic survey, deep reflection profiles and shallow reflection profiles	8.3.1.17.4.3.1	Stovepipe Wells, Yucca Mountain, Indian Springs. Precise location to be determined.	Magnetic determinations along profiles at 10 to 20 ft (3 to 6 m) spacing where accessible by truck, 50 to 100 ft (15 to 30 m) spacing elsewhere	DTP only if seismic surveys run	Assists interpretation of seismic results
Site ground magnetic surveys	8.3.1.17.4.7.4	Yucca Mountain (Figure 8.3.1.4-9)	Ground magnetic surveys at (1) known and inferred structures, (2) vicinity of drillholes, (3) vicinity of shaft and surface facilities, (4) anomalies detected. Surveys to be semicontinuous: 10 to 20 ft (3 to 6 m) spacing	Number and location to be determined through evaluation of geologic and geophysical mapping	Primary purpose is to locate concealed extensions of faults. See Bath and Jahren (1984), Scott et al. (1984), and Bath and Jahren (1985)
Curie isotherm	8.3.1.8.5.2.1	Yucca Mountain region	Analysis of existing regional aeromagnetic data	None	Purpose is to map configuration of Curie isothermal surface, and to compare areas of shallow isotherms with areas of high heat flow and recent volcanism. See Connard et al. (1983).

8.3.1.4-53

CONSULTATION DRAFT

Table 8.3.1.4-4. Summary of geophysical studies for Program 8.3.1.4 (rock characteristics)
(page 8 of 9)

Method	SCP section	Location	Scope	Decision points	Comments
<u>Electrical methods</u>					
Regional magnetotelluric (MT)	8.3.1.17.4.3.1	Yucca Mountain, Crater Flat, Jackass Flats, Amargosa Desert, Death Valley (Figure 8.3.1.17-12)	Detailed survey with stations at 3 to 5 km spacing of Yucca Mountain, Crater Flat, and northern Amargosa Desert. Reconnaissance survey with stations at 10 km spacing in remainder of area	None	Previous survey by Furgerson (1982) shows mappable conductivity contrasts in 1 to 15 km depth range. See also Kauahikaua (1981), and Hoover et al. (1982)
Surface geoelectric investigations (airborne EM, slingram, VLF, dc resistivity, EM soundings, tensor audio magnetotelluric and telluric profiling filing)	8.3.1.17.4.7.5	Yucca Mountain	Assess potential for application of these methods, evaluate previous results, plan new applications if appropriate, conduct prototype tests	DTP with fullscale application of selected methods only if warranted by results of prototype testing	Applied to structural and stratigraphic problems at the site by Flanigan (1981), Smith and Ross (1982), Fitterman (1982), Hoover et al. (1982), Senterfit et al. (1982), Scott et al. (1984), Frischknecht and Raab (1984). Other studies in region include Zablocki (1979), Anderson et al. (1982), Smith et al. (1981), Greenhaus and Zablocki (1982).
<u>Radiometric and remote sensing methods</u>					
Surface and airborne gamma ray investigations	8.3.1.17.4.7.6	Yucca Mountain	Assess potential for application of these methods with preliminary survey over known faults using static ground measurements	DTP with full-scale application of airborne methods only if warranted by results of preliminary survey	Could detect percolation of radon through fault zones (gamma emitting daughter bismuth-214)

8.3.1.4-54

CONSULTATION DRAFT

Table 8.3.1.4-4. Summary of geophysical studies for Program 8.3.1.4 (rock characteristics)
(page 9 of 9)

Method	SCP section	Location	Scope	Decision points	Comments
Thermal infrared investigations	8.3.1.17.4.7.7	Yucca Mountain	Assess potential for application of aircraft and satellite thermal infrared imagery in mapping of fracture network	DTP based on evaluation of cost and expected results	Method depends on detection of surface temperature variation, which are largely dependent on soil moisture content, which in turn is in part related to infiltration along fractures.
Thematic Mapper Satellite Imagery	8.3.1.17.4.7.7	Yucca Mountain and vicinity	Tapes of the four Thematic Mapper V scenes encompassing the Yucca Mountain Region (Beatty, Indian Springs, Pahute Mesa, and Pahranaqat 1:100,000 quads) to be used to produce spectral and spectral ratio maps, from which areas containing distinctive patterns of lineations will be delineated.	None	Used to define structural domains, areas of well-developed desert varnish, and areas of hydrothermal alteration.
<u>Paleomagnetism</u>					
Region	8.3.1.17.4.7.2	Little Skull Mountain, Crater Flat, Skull Mountain, southern Yucca Mountain, eastern Yucca Flat.	10 to 20 sites at Little Skull Mountain will be sampled. If useful results are obtained, other sites as listed may be sampled.	DTP only if useful results obtained at Little Skull Mountain, and if suitable strata are present.	Preliminary results at Yucca Mountain indicate 30 degrees rotation (Scott and Rosenbaum, 1986)

CONSULTATION DRAFT

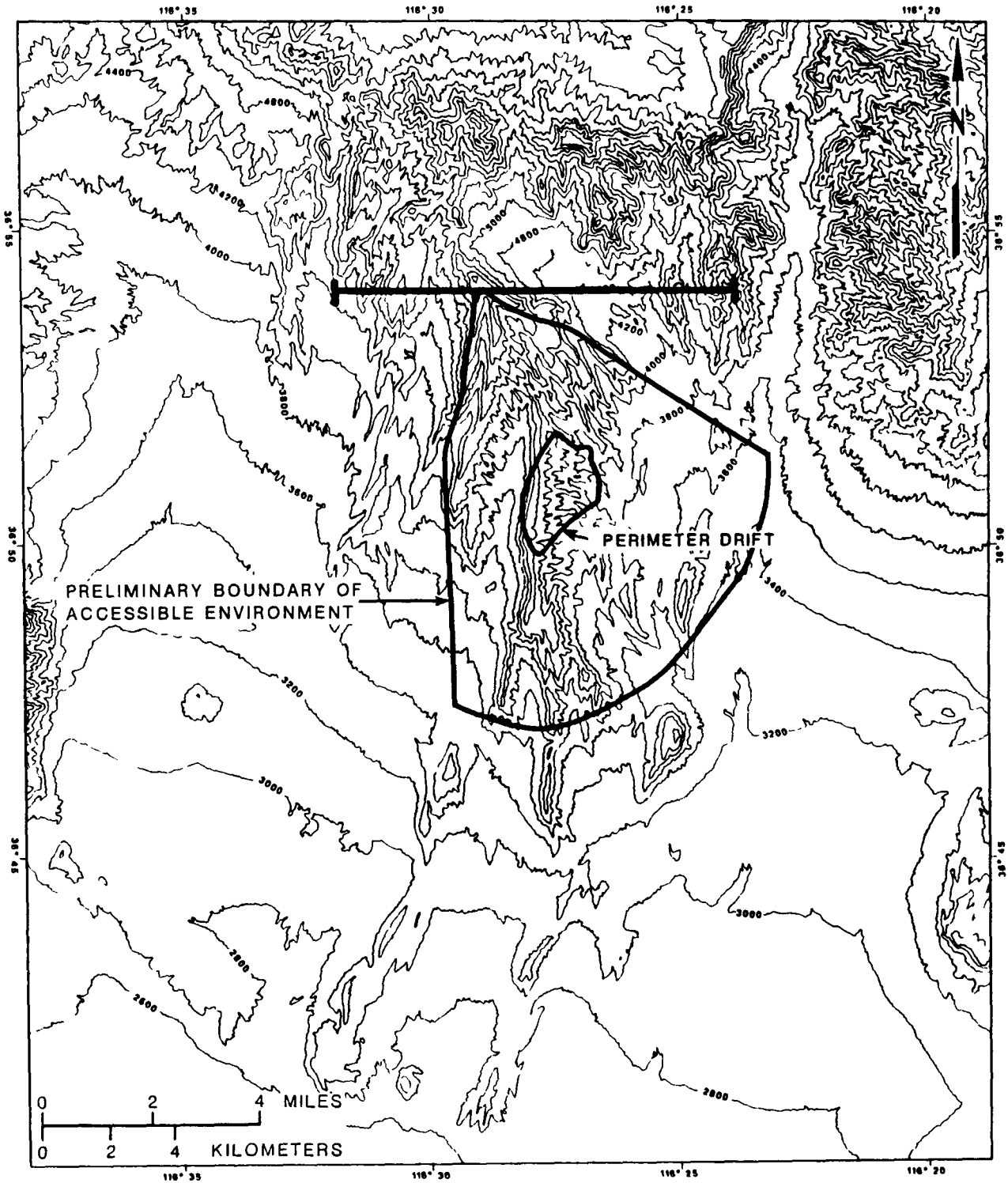

Figure 8.3.1.4-7. Approximate location of proposed seismic refraction survey across Yucca Wash.

CONSULTATION DRAFT

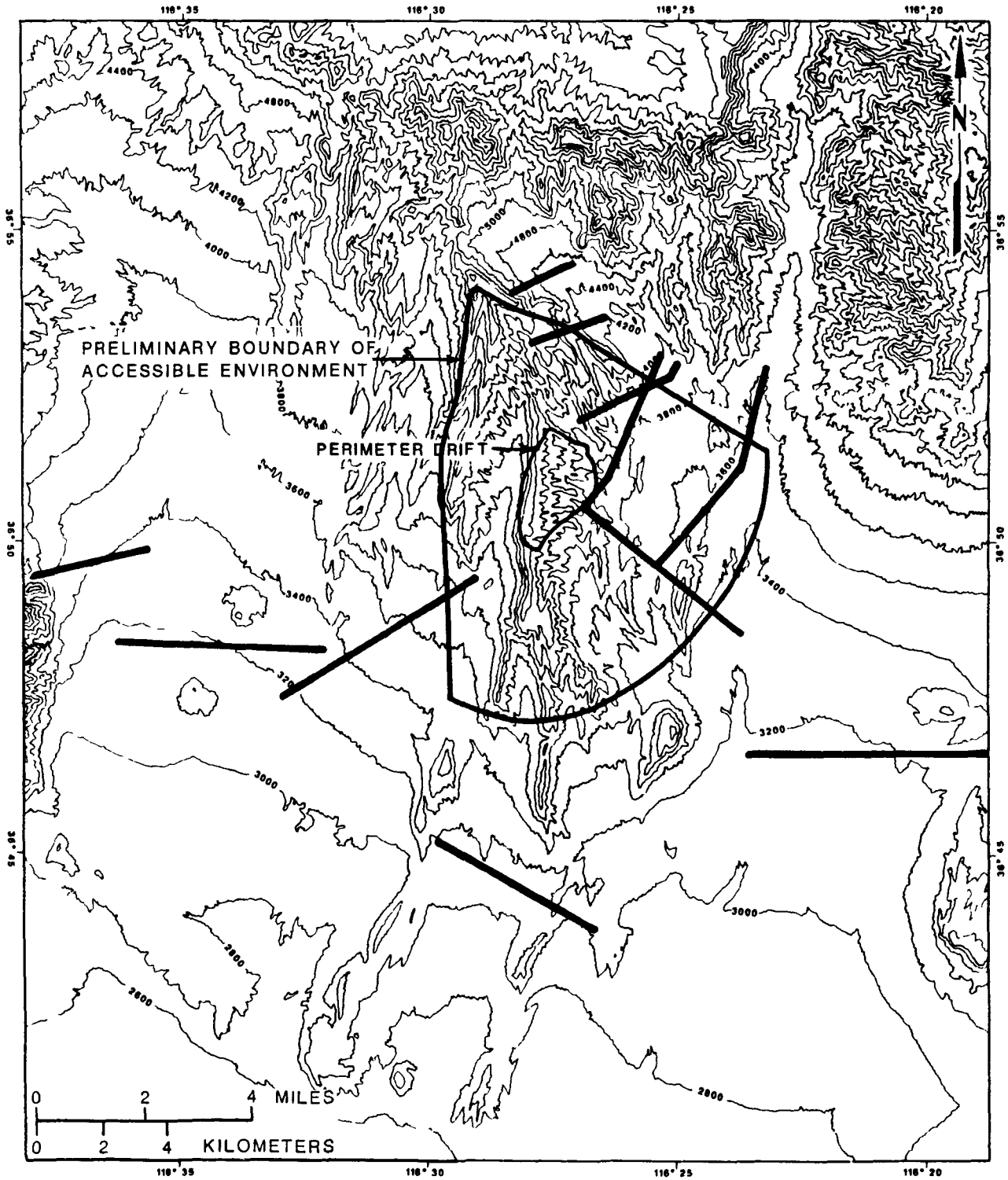

Figure 8.3.1.4-8. Approximate location of proposed seismic reflection surveys at Yucca Mountain

CONSULTATION DRAFT

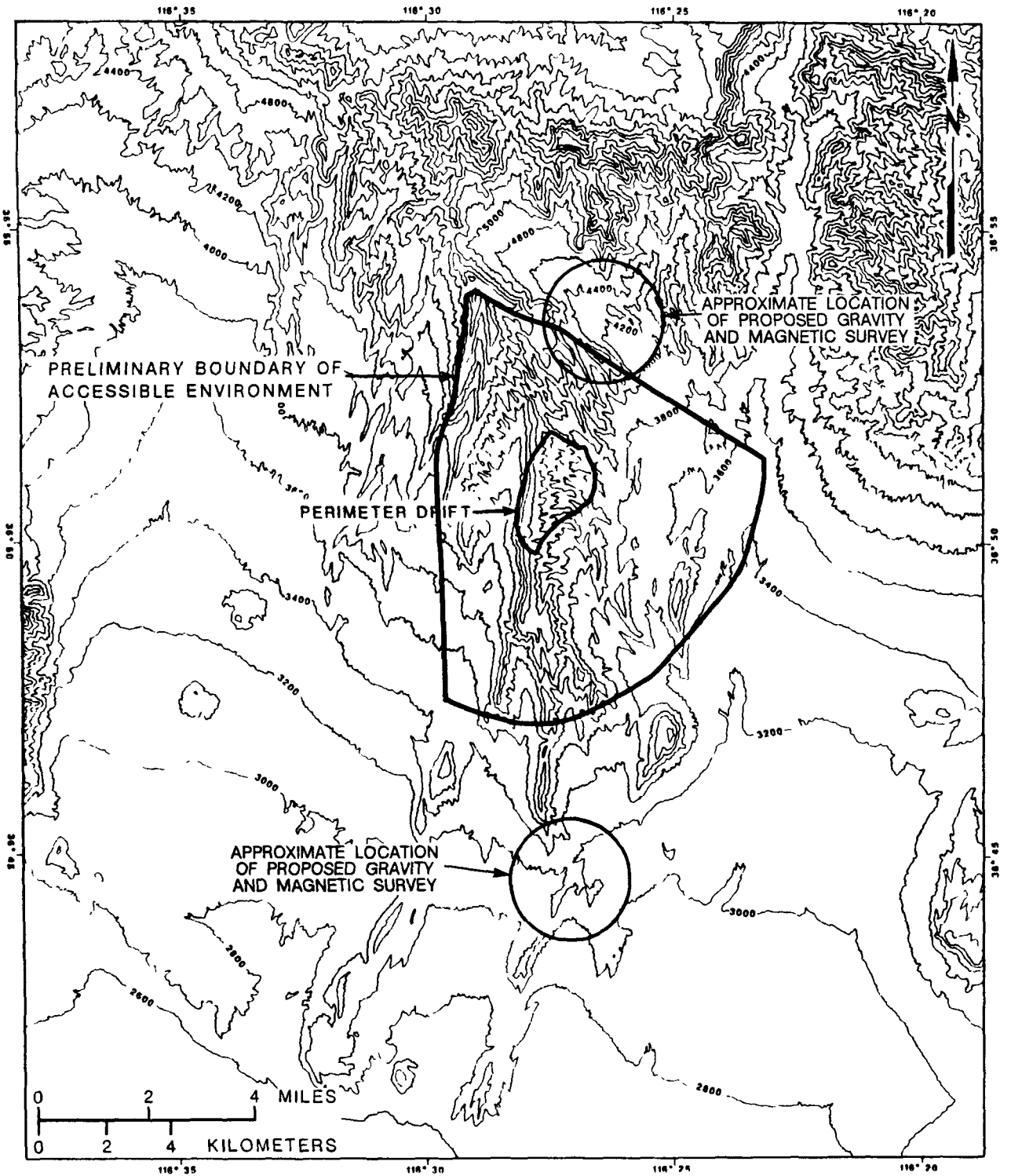

Figure 8.3.1.4-9. Approximate locations of proposed gravity and magnetic surveys near proposed coreh

CONSULTATION DRAFT

surveys are more completely described in Activities 8.3.1.17.4.4.1 and 8.3.1.17.4.4.4. In addition, a program of intermediate seismic reflection in the vicinity of Yucca Mountain is planned in Activity 8.3.1.17.4.7.1, using such sources as vibrators, explosives, and air guns. The locations of these seismic lines will be determined after further acquisition and analysis of tectonic data using criteria that will include obtaining the requisite stratigraphic information needed to input to the geologic model of the site.

Gravity and magnetic data will be acquired at 500-ft intervals along the same surface profiles as the intermediate seismic data and shallow seismic surveys. In addition, a site gravity map at a scale of 1:24,000 is proposed (Activity 8.3.1.17.4.7.2), for which as many as 7,500 gravity stations would be required. The stations would be located at 200-ft intervals along lines spaced about 500 ft apart. An aeromagnetic survey is proposed which would produce a higher resolution map (1:24,000 scale) than previous surveys (Bath and Jahren, 1984; Kane and Bracken, 1983; Jansma et al., 1982; Bath et al., 1982), but over a smaller region. Additional gravity and ground magnetic surveys may be performed to investigate aeromagnetic anomalies, the location of proposed shafts and repository surface facilities.

Various electrical methods including airborne electromagnetic (EM) surveys, EM soundings, tensor audio magnetotellurics, telluric profiling, and direct current resistivity will be evaluated for application to tectonic, structural, and stratigraphic problems in Activity 8.3.1.17.4.7.5. In addition, radiometric (airborne gamma intensity) and remote sensing methods (thermal infrared scanner and Thematic Mapper V) will be evaluated in Activities 8.3.1.17.4.7.7 and 8.3.1.17.4.3.5 for application to detection of faults and fractures at the surface. Radiometric or surface temperature anomalies may be associated with radon emanation or water infiltration, respectively, along faults or fractures. Application of these electrical and remote sensing methods for site characterization will depend on the outcome of feasibility tests.

Electromagnetic surveys will be performed to investigate the thickness of the volcanic section and fault trends in Yucca Wash (near USW G-5). Alteration zones associated with fault zones will be evaluated and may provide evidence of hydraulic connectivity of the inferred fault system.

Methods and technical procedures

The methods and technical procedures for Activity 8.3.1.4.2.1.2 are given in the following table.

CONSULTATION DRAFT

Method	Technical procedure		Date
	Number	Title	
	(NWM-USGS-)		
Seismic refraction surveys	SP-08, RO	Seismic study of the tectonic environment	6 June 83
	TBD ^a	Seismic refraction surveys	TBD
Seismic reflection surveys	TBD	Mini-sosie surveys	TBD
Gravity surveys	GPP-01, RO	Gravity measurement and data reduction	14 Jan 85
Magnetic surveys	TBD	Surface-based magnetic surveys	
Electromagnetic surveys	GPP-18, RO	Magnetotelluric measurements	27 May 86

^aTBD = to be determined.

8.3.1.4.2.1.3 Activity: Borehole geophysical surveys

Objectives

The objectives for this activity are (1) to aid in the definition and refinement of the location and character of lithostratigraphic units and contacts between units and (2) to determine the distribution of rock properties within lithostratigraphic units.

Parameters

The parameters for this activity are the direct measurements and quantities derived from geophysical logs, statistical analysis, cross plots, and correlation with core data, including the borehole diameter, in situ bulk density, electrical conductivity, resistivity, spontaneous potential, gamma radiation intensity, temperature, induced polarization, porosity, saturation, potassium-uranium-thorium (K-U-Th) content, water content, seismic velocities, deformation moduli, magnetic susceptibility, and total magnetic field intensity.

Description

A suite of commercially available geophysical logs will be obtained in future holes drilled in the vicinity of Yucca Mountain. Additional

CONSULTATION DRAFT

experimental geophysical logs also will be obtained in selected boreholes. Geophysical log data will be correlated with measurements of properties such as porosity, saturation, water content, seismic velocity (in the unsaturated zone), deformation moduli, magnetic susceptibility, total magnetic field intensity, K-U-Th content, and hydraulic conductivity.

Compensated-density, induction, resistivity, and spectral-gamma logs will be used most frequently for lithologic correlations, although other logs may be used such as caliper, spontaneous potential, temperature, neutron, and induced polarization. Signatures of compensated-density logs will provide information to identify dominant lithophysal zones in boreholes where only drill bit-cutting samples will be available, or where poor resolution exists on borehole video-camera logs. Induction, resistivity, and spectral-gamma logs are expected to serve as indicators of smectite- and zeolite-rich intervals. These logs also will be used to identify key stratigraphic markers at the top and base of major ash-flow tuffs, which commonly show an increase in alteration.

Borehole samples, borehole video-camera logs, and geophysical logs will be correlated to help determine the vertical and lateral continuity of the lithostratigraphic units. Geophysical log data will provide rock property data for the unsaturated and saturated zone hydrology models and mechanical and thermal models of the host rock and surrounding units.

Borehole gravimetry will be used in available boreholes to obtain bulk density and structural information for the region around each hole. In addition, data from this technique will be used to study lithophysal zones, and to model the Tertiary-Paleozoic surface at the site. Gravimeter logs have been obtained for several holes (UE-25p#1, UE-25c#1, and USW H-1) including several which were continuously cored (USW G-3 and G-4). Additional logs will be acquired from as many as 15 of the existing and proposed water table holes which are nearest the site, existing deep holes as available, and all of the proposed holes which penetrate the base of the Topopah Spring Member.

Large spacing electromagnetic (EM) and resistivity logging will be tested and evaluated to determine applicability for studying fracture and lithophysal zones, and for interpreting anomalies detected by means of other borehole and surface geophysical methods. The application of these methods to acquisition of site characterization data will depend on the outcome of preliminary testing.

Methods and technical procedures

The methods and technical procedures for Activity 8.3.1.4.2.1.3 are given in the following table.

CONSULTATION DRAFT

Method	Technical procedure		Date
	Number	Title	
	(NWM-USGS-)		
Borehole geophysical surveys and logging	GP-02, RO	Subsurface investigations	1 Mar 83
	GPP-12, RO	Borehole gravity measurement and data reduction	20 Mar 85
	GPP-14, RO	Induced polarization borehole logging operations	27 May 86
	TBD ^a	NNWSI Project logging procedures	TBD
	TBD	Statistical analysis of borehole geophysical log data	TBD

^aTBD = to be determined.

8.3.1.4.2.1.4 Activity: Petrophysical properties testing

Objectives

The objective of this activity is to provide geophysical and rock property data to be used in the interpretation of surface-based and borehole geophysical surveys.

Parameters

The parameters for this activity are

1. Electrical resistivity and bulk density of core samples containing in situ pore waters.
2. Electrical resistivity, induced polarization, bulk density, grain density, porosity, seismic velocities, and hydraulic conductivity on resaturated samples.

Description

Rock property testing will provide data for use in the interpretation of surface and borehole geophysical surveys (Activities 8.3.1.4.1.1.2 and

CONSULTATION DRAFT

8.3.1.4.1.1.3). Laboratory measurements will be made on core samples obtained from boreholes drilled in the area of interest. Mechanical and thermal properties determined by those testing activities described in Investigation 8.3.1.15.1 and other activities under Investigation 8.3.1.4.2 will also be used in interpretation of geophysical surveys.

This activity will provide data on (1) the degree of water saturation within the rock above the static water level, (2) the moisture flux through the rock matrix, (3) preferential paths for water flow, (4) the potential for contaminant transport by means of diffusion processes, (5) concentrations of clays and zeolites within the measured stratigraphic section, (6) statistical relationships of various rock properties to provide information on the degree of welding, alteration, and compositional uniformity, and (7) rock property variation for integration in a three-dimensional geophysical model of the site.

Methods and technical procedures

The methods and technical procedures for Activity 8.3.1.4.2.1.4 are given in the following table.

Method	Technical procedure		Date
	Number	Title	
	(NWM-USGS-)		
Laboratory measurements of rock properties	GPP-10, RO	Rock properties analysis of Yucca Mountain core samples	16 Jan 85

8.3.1.4.2.1.5 Activity: Magnetic properties and stratigraphic correlations

Objectives

The objectives of this activity are to

1. Provide magnetic property data to aid the interpretation of volcanic stratigraphy and structure of rock units within the Yucca Mountain site area.
2. Use paleomagnetic directions to provide orientations for drill core segments.
3. Assess the rotation of rock units in relation to the geologic structures of Yucca Mountain from paleomagnetic indications.

CONSULTATION DRAFT

Parameters

Three categories of parameters are required for this activity.

Measured magnetic parameters:

1. Orientation and magnitude of remanent magnetism.
2. Magnetic susceptibility.
3. Curie temperature.

Measured properties of flow units:

1. Textural variations across boundaries.
2. Grain size variations.
3. Pumice clast concentrations.
4. Locations of lithic-rich subzones.
5. Nature of contacts between flow units.

Inferred properties of flow units:

1. Locations of deposition breaks.
2. Thicknesses of individual flow units.

Description

Natural remanent magnetization (NRM) and magnetic susceptibility exhibit systematic variation that correlates with depositional breaks within several major ash-flow tuffs. Data will be collected to help understand the observed mineralogical variations that produce the observed changes in magnetic susceptibility and remnant magnetization. Empirical relationships will be developed between depositional breaks and variations in these magnetic properties to provide information for the three-dimensional geologic model.

Lithologic relationships will be developed based on observations of the following rock properties: (1) measurement of NRM, (2) measurement of anhysteritic remanent magnetization (ARM), (3) measurement of isothermal remanent magnetization (IRM), (4) measurement of saturation magnetization (M_{sat}), (5) measurement of magnetic susceptibility, (6) alternating field demagnetization, (7) thermal demagnetization, and (8) curie temperature determination.

Oriented samples for rock magnetic properties testing will be collected from surface outcrops in the vicinity of Yucca Mountain. Sampling sites will be selected where geologic evidence indicates that the area is relatively undisturbed and the identity of the unit sampled is well known. These sites are used to establish reference paleomagnetic directions for geologic units. Other sites will be selected where rotations of the geologic structure will be evaluated. Data from these sites will be used to assess the magnitudes of the rotations.

Samples have been collected from drill core segments at 3-m intervals from throughout drillholes USW G-1, USW G-2, USW GU-3, and USW G-3. Samples also have been collected from throughout the sections penetrated by two

CONSULTATION DRAFT

drillholes located on Crater Flat (VH-1 and VH-2). Further sampling from drill core will be obtained from oriented core segments.

Variations in magnetic properties determined in the laboratory will be used to select intervals of core from drillholes USW G-1, USW G-2, USW GU-3, and USW G-3 for detailed petrographic studies. Studies will focus on identifying subtle variations across contacts that separate subunits of major ashflow tuffs. These features include textural changes, localized concentrations of pumice clasts and lithic fragments, anomalous welding characteristics, and subtle compositional changes that may correlate with abrupt changes in magnetic properties.

Measurement of NRM and remanent magnetization will be determined with a spinner magnetometer after at least one level of alternating field demagnetization. Progressive alternating field and thermal demagnetization will help assess mineralogical variations within the rock. Additional rock magnetic measurements (ARM, IRM, M_{sat}) will be used to help assess variation in the composition, relative abundance, and magnetic grain size of magnetic minerals. Selected samples are subjected to progressive thermal demagnetization in order to determine blocking temperature spectra, and to assess whether samples possess multiple components of remanent magnetization. Curie temperatures will be determined from rock chips of mineral separates to help define the magnetic minerals present in the samples.

Measurements of the relative magnitude of magnetic susceptibility will be obtained using a hand-held magnetic susceptibility meter. This meter will provide relative values, and will help limit the size of intervals of core selected for petrographic studies. If this technique proves to be successful, the instrument will be used in continuously cored holes.

To measure total intensity and magnetic susceptibility variation with depth, borehole magnetic surveys using an experimental flux-gate magnetometer, proton-spinner magnetometer, and susceptometer will be performed as described in Activity 8.3.1.4.2.1.3. These logs will be correlated with available geologic data. Geologic correlations will focus on identifying depositional units and rock characteristics changes in the Topopah Spring Member.

Methods and technical procedures

The methods and technical procedures for Activity 8.3.1.4.2.1.5 are given in the following table.

CONSULTATION DRAFT

Method	Technical procedure		Date
	Number	Title	
	(NWM-USGS-)		
Sampling, examination and petrographic analysis of selected intervals of core and outcrop	MDP-01, RO	Identification, handling, storage, and disposition of drillhole core and samples	15 Oct 81
	GP-02, RO	Subsurface investigations	1 Mar 83
	GP-05, RO	Geologic support activities	1 Mar 83
	GP-19, RO	Procedure for the identification, handling, and disposition of drillhole core and cutting samples from the drill site to the core library	6 Mar 87
Density variation in rock mass	GP-14, RO	Measurement of dry bulk rock densities from paleomagnetic samples	25 Sept 86
Use of the hand-held magnetic susceptibility meter	GPP-06, RO	Rock and paleomagnetic investigations	1 Nov 84
Borehole magnetic surveys and logging	GPP-15, RO	Magnetic susceptibility borehole logging operation	27 May 86
	GPP-17, RO	Magnetometer borehole logging operations	27 May 86
Sampling, and paleomagnetic testing and analysis of selected intervals of core and outcrop	TBD ^a	NNWSI Project logging procedure	TBD

CONSULTATION DRAFT

Method	Technical procedure		Date
	Number	Title	
	GPP-06, RO	Rock and paleomagnetic investigations	1 Nov 84

^aTBD = to be determined.

8.3.1.4.2.2 Study: Characterization of the structural features within the site area

The objective of this study is to determine the frequency, distribution, characteristics, and relative chronology of structural features within the Yucca Mountain site area.

Surface and subsurface structural studies will be performed to identify and characterize fracture-fault systems within the site area. Detailed geologic mapping of zonal features in ash-flow tuffs that crop out at the surface of Yucca Mountain will provide the necessary stratigraphic control for identifying small-scale faults. Lateral variability of fracture networks will be studied by detailed mapping and pavement analysis. Subsurface distribution and geologic characteristics of fracture-fault zones will be studied by analysis of core samples, borehole evaluations, exploratory shaft studies, and application of geophysical techniques. Results of these studies will be integrated with hydrologic study results described in Section 8.3.1.2 to provide information for the development of geologic models of the site (Study 8.3.1.4.2.3).

Geologic mapping of the exploratory shaft and drifts will include detailed fracture mapping and photogeologic recording. Borehole evaluations in the exploratory shaft facility after drilling and coring, will include video, geophysical and vertical seismic profiling surveys. Fracture-filling mineralogy studies in the shaft, drifts, and boreholes will be conducted to evaluate the chronology of fracture development.

Activities planned for this study include (1) geologic mapping of zonal features in the Paintbrush Tuff at a scale of 1:12,000, (2) surface-fracture network studies, (3) borehole evaluation of fractures and faults, (4) geologic mapping of the exploratory shaft and drifts, and (5) vertical seismic profiling studies.

CONSULTATION DRAFT

8.3.1.4.2.2.1 Activity: Geologic mapping of zonal features in the Paintbrush Tuff at a scale of 1:12,000

Objectives

The objectives of this activity are (1) to map zonal variations within exposed tuffs that will aid in the identification of structural displacements at a scale of 10 m or less, and (2) to detect subtle changes in structural styles.

Parameters

The parameters for this activity are

1. Thickness, attitudes, and lateral extent of zones within ash-flow and bedded tuff intervals, areal extent of exposed bedrock.
2. Attitudes, lengths, displacements, and near-surface characteristics of faults and fault zones.

Description

Geologic mapping of zonal variations in ash-flow sheets and structural features that are exposed over much of the site area has been completed and published at a scale of 1:12,000. The mapped area forms an irregular pattern, the boundaries of which roughly coincide with prominent topographic features (Figure 8.3.1.4-10, Area A). The northernmost limit of the map is Prow Pass; the northeastern boundary is Yucca Wash; the eastern limit is Fortymile Wash; the southern extent is the southernmost exposure of Fran Ridge; and the western limit is Windy Wash.

Mapping will extend outward from the western and southern boundaries of the mapped area to include areas east of longitude 116° 32' and areas north of latitude 36° (Figure 8.3.1.4-10, Area B). The mapping will identify thickness, attitude, and lateral extent of zones within ash-flow tuffs and bedded tuff intervals; areal extent of exposed bedrock; and attitudes, lengths, displacements, and near-surface characteristics of faults and fault zones. Northern, northeastern, and eastern limits of the map area will not be extended because rock units of interest are poorly exposed in those areas. The need for larger scale mapping (e.g., 1:2,400) in the immediate vicinity of the repository facilities will be assessed.

Geologic information that is initially documented on aerial photographs during field mapping will be transferred to stable topographic base maps by using high-precision photogrammetric techniques.

Methods and technical procedures

The methods and technical procedures for Activity 8.3.1.4.2.2.1 are given in the following table.

CONSULTATION DRAFT

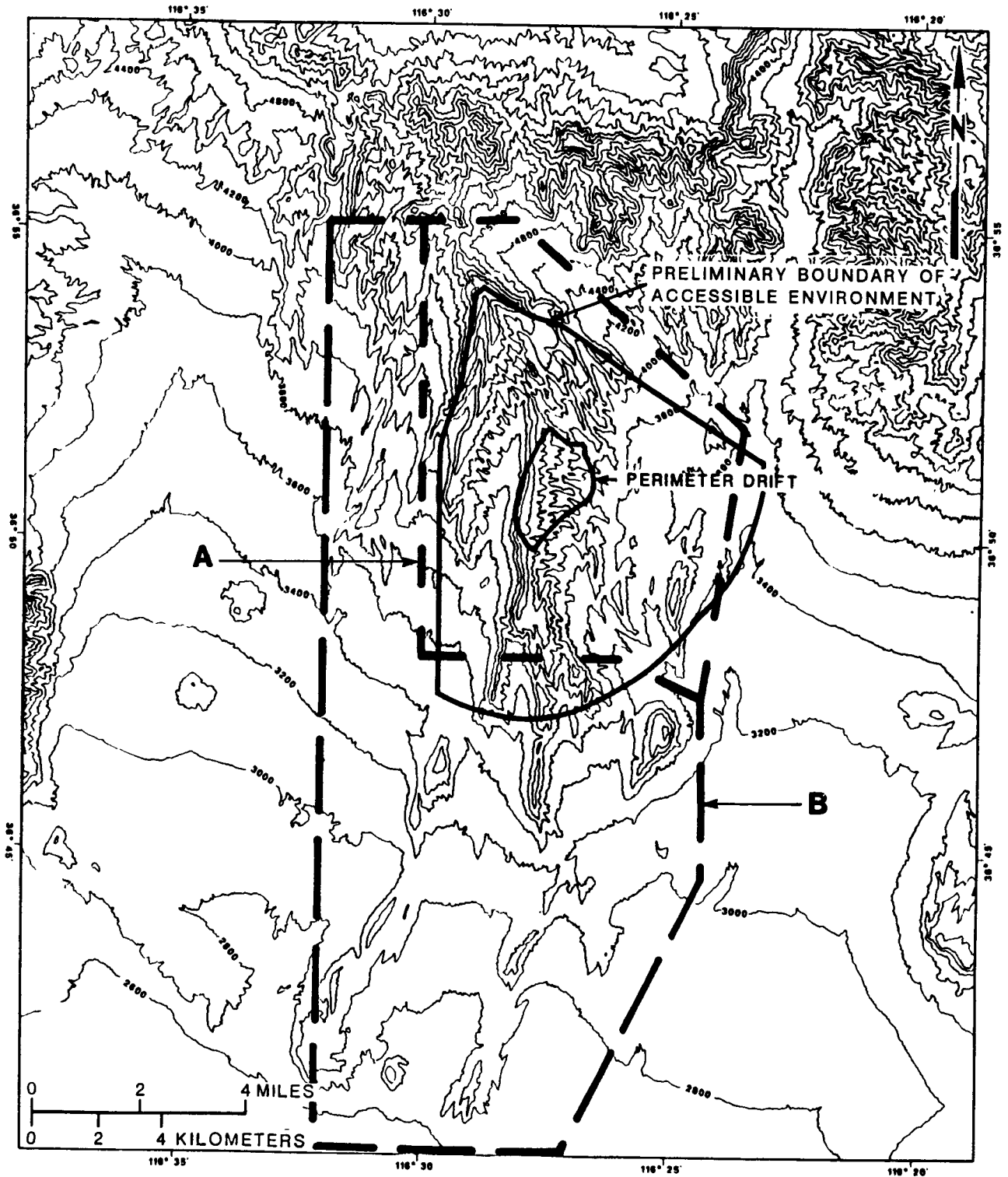

Figure 8.3.1.4-10. Approximate areal limits of mapped area (A) and area of additional mapping (B).

CONSULTATION DRAFT

Method	Technical procedure		Date
	Number	Title	
	(NWM-USGS-)		
Field mapping using 1:12,000-scale aerial photographs	GP-01, RO	Geologic mapping	1 Mar 83
Transfer of geologic features to topo- graphic base maps using high-precision photogrammetric techniques	GP-01, RO	Geologic mapping	1 Mar 83

8.3.1.4.2.2.2 Activity: Surface-fracture network studies

Objectives

The objective of this activity is to provide fracture parameters and analyses in support of hydrologic modeling of potential flow paths, particularly in the unsaturated zone. The analyses will provide quantitative approaches to determining spatial distribution of fractures, chronology of fracture development, and parametric characteristics of fractures. Applications are expected to aid development of tectonic models and possibly to aid determination of the bulk response of fractured rock in the context of excavation and loading.

Parameters

The parameters for this activity are fracture orientation, aperture, roughness, trace length, spatial distribution, interconnectedness, and fracture-filling mineralogy.

Description

The characterizations of fracture networks on the surface of Yucca Mountain will be carried out through a phased program of detailed studies of natural outcrops. Because analyses of fractures in drillholes (Activity 8.3.1.4.1.2.3), and exposed in the exploratory shaft (Activity 8.3.1.4.1.2.4) are based on relatively small samples that emphasize the vertical dimension, analyses based on surface exposures of fractures provide a unique opportunity to understand the character of fracture networks and spatial distribution. Preliminary work indicates that most fractures are strata-bound. Therefore, fluid flow paths through fractures depend to a large degree on the intersections of fracture networks at the strata boundaries. The outcrops which provide two-dimensional surfaces through three-dimensional fracture networks,

CONSULTATION DRAFT

will be selected to obtain the most effective samples of as many subunits as possible of the Paintbrush Tuff. Analyses will proceed only if sample areas continue to be representative of the stratigraphic sequence in the repository block.

The exposures will be mapped in the field on aerial photographs at a scale of approximately 1:50. Only fractures longer than 0.20 m will be mapped. After the exposures are mapped in detail, a fracture data base will be constructed from measurements and descriptions of the following fracture characteristics: (1) orientation, (2) aperture, (3) roughness, (4) trace length, (5) interconnectivity, and (6) fracture-filling material.

A fractal analysis of each exposure will be performed to quantify the spatial distribution of fracture traces, and fracture trace intersections. The utility of fractal description is based partly on the capability to describe geometric observations on different scales, using an approach that is independent of scale. Fractal descriptions may also serve as a means to identify and study spatial variation in network geometry. Fractal analysis offers the best available technique to characterize the complex three-dimensional fracture systems in the repository block, given the sparse observational data that can be obtained. Other analysis methods will be applied to the fracture data base where appropriate.

The data collected on the other parameters listed previously will be analyzed in various ways. Fracture orientations (strike and dip) of each network will be plotted onto lower hemisphere equal-area projections and examined for groupings into preferred sets. Fracture trace-lengths, aperture, and roughness frequency distributions will be plotted and characterized for each fracture network.

Photogeologic mapping of fracture traces will be investigated as a technique for documenting local fracture patterns and determining the degree of variation among them. Fracture traces will be mapped from black and white 1:2,400-scale aerial photographs by means of a Kern PG-2 mechanical stereoplotter. Data are traced directly onto a topographic base sheet oriented to the aerial photographs. The area covered by the photogeologic map will be determined by the areal coverage of the photograph set and the areas on the photographs where fracture traces are visible. Measurements from the photogeologic map will be limited to measuring the bearing of the fracture trace, measured directly from the base sheet.

Field work will be initiated as a means of checking the validity of fracture trace orientations measured from the photogeologic map. Areas selected on the photogeologic map will be located in the field. The number of areas selected will be based on the number determined to be representative of the photogeologic traces. Bearings of all exposed fracture traces are recorded from each area.

Methods and technical procedures

The methods and technical procedures for Activity 8.3.1.4.2.2.2 are given in the following table.

CONSULTATION DRAFT

Method	Technical procedure		Date
	Number	Title	
	(NWM-USGS-)		
Mapping of fracture traces from low-altitude aerial photography	TBD ^a	Surface-fracture trace mapping on aerial photographs	TBD
Outcrop studies	GP-12, R1	Mapping fractures on pavement outcrops and along traverses	6 Mar 87
Fracture mapping of hydraulically exposed pavements and natural washout strips	GP-12, R1	Mapping fractures on pavement outcrops and along traverses	6 Mar 87
Statistical analysis of data, including fractals	GP-12, R1	Mapping fractures on pavement outcrops and along traverses	6 Mar 87

^aTBD = to be determined.

8.3.1.4.2.2.3 Activity: Borehole evaluation of faults and fractures

Objectives

The objectives of this activity are to

1. Assess the reliability and usefulness of available borehole techniques for identifying and characterizing the subsurface fracture distribution.
2. Determine vertical and lateral variability and characteristics of subsurface fractures.
3. Identify subsurface characteristics of fault zones.

Parameters

The parameters for this activity are

1. Fracture location, dimension, type, orientation, relative chronology, aperture, degree of mineralization, mineralogy of fillings, surface profile, roughness coefficient, and apparent frequency.

CONSULTATION DRAFT

2. Lateral variability in apparent fracture frequencies and strike directions of fractures within lithostratigraphic units, and subsurface fracturing closely associated with fault zones.

Description

Analysis and interpretation of subsurface characteristics of faults and fractures in the site area will, in part, be based upon (1) core sampling and fracture logging, (2) borehole video camera logging, (3) acoustic televiewer surveys and logging.

Fracture and fault studies in continuous core will help determine the relative spatial relationships of these features. Measurements will include maximum dimension, relative chronology, apertures, and fracture surface characteristics (such as surface profile and roughness coefficient), degree of mineralization, and mineralogy of fillings. Attitudes of fractures and faults will be obtained by analysis of oriented cores and by orienting segments of core based on reorientation using paleomagnetic techniques (Activity 8.3.1.4.2.1.5).

Careful reconstruction and analysis of core segments will not eliminate many of the sampling limitations that are inherent to the study of fractures in near-vertical coreholes, particularly at Yucca Mountain where vertical fractures dominate. Characterization of fractures in core provides only one dimension of the total fracture network and will be integrated with surface studies that provide information from other sampling orientations to help understand sample bias in corehole data. The relatively small sample size of core also precludes the study of fracture dimensions. No distinction can be made between large, through-going fractures and fractures that have very short trace lengths. Future coreholes will be used to aid in planning studies in the exploratory shaft and associated drifts (Activity 8.3.1.4.2.2.4) where more accurate observations of three-dimensional fracture networks can be made.

A continuous visual display of borehole walls will be obtained in future holes drilled in the vicinity of Yucca Mountain by using an instrument assembly that includes a borehole television camera, compass, light source, and digital depth readout. Video-camera tapes will be reviewed and the location, orientation, and relative abundance of fractures will be recorded. Fracture data will be compiled to show changes in the apparent frequency of fractures as a function of depth, stratigraphic unit, and lithostratigraphic unit. Directional orientation histograms will be constructed that illustrate distribution of strike and dip directions within appropriate lithostratigraphic and stratigraphic units. These types of compilations will provide a means for estimating the degree of lateral variability in apparent fracture frequencies and strike directions of fractures within lithostratigraphic units, and provide a means for estimating subsurface fracturing closely associated with fault zones.

Acquisition of a continuous record of fractures intersecting a borehole is the primary advantage of using oriented borehole television to map fractures in the subsurface. However, several limitations of the method can be identified that limit the characterization of fracture networks. They include the following:

CONSULTATION DRAFT

1. Data are biased because vertical fractures are not adequately sampled as in core studies.
2. Only one dimension of the fracture network is sampled.
3. Inaccuracies in identifying and measuring the toes and heels of fracture planes that cut the borehole limit data acquisition to strike and dip directions only; the amount of dip of fracture planes often cannot be confidently measured and, therefore, true fracture spacings cannot be obtained.
4. Important fracture parameters that are useful for characterizing fracture sets, such as trace lengths, roughness, and mineral coatings, cannot be measured.

The significance and validity of subsurface fracture analyses based on core and television camera logging will depend largely on comparison with results of fracture analyses conducted in the exploratory shaft and associated underground workings.

Acoustic televiewer logging is an additional technique that can be used to study the distribution of fractures in the saturated zone by inspection of borehole walls. The televiewer provides an oriented image of the acoustic scattering profile of the borehole, in the form of a continuous log. The borehole is displayed on the log as if it were split vertically along magnetic north and unrolled onto a vertical plane. Nonvertical fractures form distinctive sinusoidal features that can be used to measure strike and dip directions as well as the amount of dip.

Fracture attitudes will be measured from existing televiewer logs as well as from logs of future holes. Data sets will be compiled to show the vertical variations as a function of depth and lithostratigraphic units. As in the analysis of fractures from video-camera observations, data will be displayed on direction orientation histograms. This will allow comparative analyses between drillholes. Unlike the video-camera log, the amount of dip often can be calculated from the televiewer log at depths where accurate determinations of hole diameters can be made from existing caliper logs. Acquisition of these data will allow application of statistical methods such as stereonet contouring to determine the significance of any preferential spatial distributions.

Several other borehole geophysical methods, including borehole-to-borehole techniques, will be evaluated in available drillholes at the site. These methods will include borehole radar, crosshole resistivity, crosshole EM, crosshole radar, and high resolution crosshole seismic surveys (Table 8.3.1.4-4). Evaluations also will involve comparative studies of the various methods used to identify subsurface fractures. Stratigraphic intervals for which fracture data are available for several subsurface techniques will be analyzed to assess the utility of each method.

CONSULTATION DRAFT

Methods and technical procedures

The methods and technical procedures for Activity 8.3.1.4.2.2.3 are given in the following table.

Method	Technical procedure		Date
	Number	Title	
Core sampling and fracture logging, including oriented core	GP-11, RO	Logging fractures in core	15 May 85
Borehole video camera surveys and logging	GP-10, RO	Borehole video fracture logging	12 Apr 85
Acoustic televiewer surveys and logging	TBD ^a	Borehole acoustic televiewer surveys	TBD

^aTBD = to be determined.

8.3.1.4.2.2.4 Activity: Geologic mapping of the exploratory shaft and drifts

Objectives

The objectives of this activity are to

1. Determine the vertical and horizontal variability of fracture networks in the exploratory shaft facility shaft, drifts, and boreholes.
2. Characterize major fault and fault zones in the subsurface.
3. Map the lithostratigraphic features of the subunits, and the abundance and character of lithophysal zones.
4. Assist in selection of test locations in the exploratory shaft test facility.

Parameters

Three categories of parameters are required for this activity.

Fault parameters:

1. Geometry.
2. Physical characteristics.

CONSULTATION DRAFT

3. Tectonic styles of faults bounding the repository on the northeast and east, and of the Ghost Dance fault.

Fracture parameters:

1. Orientation.
2. Aperture.
3. Roughness.
4. Trace length.
5. Surface characteristics.
6. Mineralogy.
7. Age.
8. Spatial distribution.

Stratigraphic parameters:

1. Lithology and petrography of Yucca Mountain stratigraphic sequence.
2. Lateral variability of repository host horizon.

Description

Figure 8.3.1.4-11 shows a conceptual layout of the exploratory shaft facility and associated drift projections to major geologic features. The subsurface structures near the northeastern and eastern boundaries of the repository could be directly studied at the ends of northeast and southeast drifts. The character of the Ghost Dance fault within the repository could be investigated at the end of a northwest drift. Lateral variability of the lithologic character of the repository host rock will be determined. Data obtained from fracture mapping in the drifts will be combined with fracture mapping data from the shaft and surface studies to describe the three-dimensional fracture network within the exploratory shaft facility.

Mapping in the shaft and drifts can provide a detailed description of stratigraphic, lithologic, and structural features. Descriptions of fracture networks and interconnections are enhanced by continuous observation because fracture spacing and attitude commonly vary over distances of tens to hundreds of meters. Both objectives can be met in a timely way by a two-tiered approach to the mapping: analysis of stereoscopic photographs of the exposed surfaces and continuous detailed mapping along reference lines.

Stereoscopic photographs will be taken of all exposed surfaces in the exploratory shaft and walls of all drifts as mining progresses; floors and working faces will not be mapped unless anomalous geologic features are exposed. Line drawings of discontinuities such as faults, other fractures, and breccia zones exposed on the walls and roof will be prepared from mosaics of the stereoscopic-photographs using close-range geologic photogrammetry.

More thorough mapping of geologic features will be done at regular intervals between mining shifts. Close-range geologic photogrammetry will provide continuous data for all exposures in the shaft and associated drifts. The shaft will be mapped along horizontal reference lines approximately 2 m apart, only if the photomosaic backup method is used. Also, the photomosaic backup method will be used in drifts, where data will be collected along one or more reference lines in the wall or roof (the number depending on the

CONSULTATION DRAFT

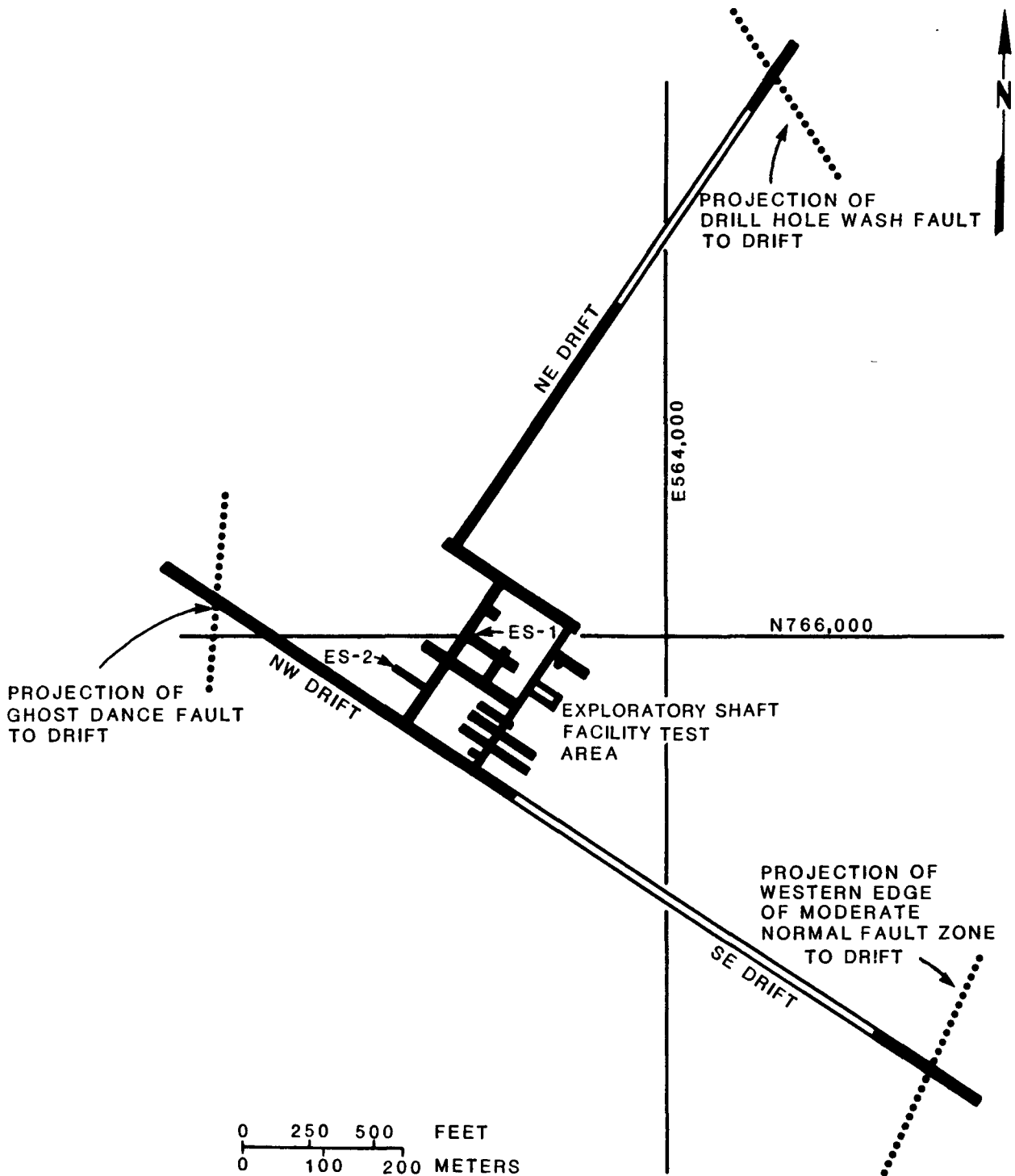

Figure 8.3.1.4-11. Proposed layout of exploratory shaft and drifts.

CONSULTATION DRAFT

amount of data needed to characterize fractures and faults). Data to be recorded and samples to be collected during in situ mapping will include (1) photographs of the drift walls and roofs, (2) fracture orientation, (3) fracture aperture, (4) fracture roughness, (5) fracture-trace length, (6) evidence and attitudes of shear on fracture surfaces, (7) fracture coatings, and (8) samples of rock representative of each stratigraphic interval. Observations of lithologic and stratigraphic features will be continuous as appropriate.

Detailed mapping will be emphasized in the area adjacent to the exploratory shaft facility tests, areas near major geologic structures within the repository, and across geologic structures near the borders of the repository. In addition, investigators will make detailed maps of test rooms and will log cores from holes drilled for hydrologic, geomechanical, and geochemical tests in the ESF test area.

If unusual pockets of alteration or fracture-filling minerals are encountered, representative samples may be acquired in conjunction with geologic mapping, as appropriate for mineralogical and age determinations. The location of origin of such samples, and the observed relationships between fracture mineralization and fracture orientation, will be recorded. Sampling of the face and muck pile for uraniferous opal or manganese-rich calcite can be aided by use of an ultraviolet lamp. Petrographic and x-ray diffraction analysis, and uranium-thorium disequilibrium dating, will be performed on collected samples.

In addition to sample collection performed by geologists as described above, two 55-gal (210 L) drums of debris will be salvaged from every round and stored at the Nevada Nuclear Waste Storage Investigations (NNWSI) Project Core Storage Facility for future use of investigations within the NNWSI Project.

Because fracture coatings are more commonly preserved underground than near the surface, they are protected to a greater degree from isotopic exchange. Uranium-thorium disequilibrium dating of calcite and uraniferous opal will be performed as a part of this activity. Electron spin resonance (ESR) dating of quartz and potassium-argon dating of clay fracture coatings from subsurface samples will be performed as a part of activities of Investigation 8.3.1.3.2.

Studies of fracture-filling mineralogy will be used to determine formation of the filling minerals to help infer the ages of fracturing and to estimate rates of tectonism. This information will be used in assessments of the potential for and likely character of additional fracturing and seismic movement at Yucca Mountain. The results of these analyses will be integrated with the evaluations planned for postclosure and preclosure tectonics and repository design.

Analyses of the ages of fracture mineralogy also provide information to aid in the interpretation of past fracture hydrologic-mineralogic processes in the repository host rock and surrounding units. These studies will be integrated with fracture mineralogy evaluations in unsaturated zone hydrology and mineralogic and geochemical activities.

CONSULTATION DRAFT

Products derived from this activity will include (1) photographic mosaics of the geologic features on the drift walls and roofs, (2) line drawings of fracture networks on the drift walls and roof, (3) fracture orientations and statistical distributions, (4) fracture-trace lengths and statistical distributions, (5) fracture intersection abundance, (6) fracture apertures and statistical distributions, (7) fracture roughness and statistical distributions, (8) two- or three-dimensional expression of fracture density, (9) three-dimensional estimate of fracture network characteristics and variability, (10) structural domains, (11) style of tectonism, (12) paleostress indications, as suggested by slickensides, (13) lithologic and petrographic description of stratigraphic sequence, (14) an assessment of lateral variability within the exploratory shaft drifts, and (15) archived representative rock samples.

Methods and technical procedures

The methods and technical procedures for Activity 8.3.1.4.2.2.4 are given in the following table.

Method	Technical procedure		
	Number	Title	Date
In situ measurement of geologic features	TBD ^a	TBD	TBD
Photogeologic recording	TBD	TBD	TBD
Shaft and drift fracture mapping	TBD	TBD	TBD
Borehole drilling and coring in the exploratory shaft and drifts	TBD	TBD	TBD
Sampling and analysis of fracture filling minerals	TBD	TBD	TBD
Dating of fracture-filling minerals	TBD	TBD	TBD

^aTBD = to be determined.

CONSULTATION DRAFT

8.3.1.4.2.2.5 Activity: Seismic tomography/vertical seismic profiling

Objectives

The objectives of this activity are to

1. Investigate, and if successful, provide a means for broadly detecting and characterizing the subsurface fracture network in regions between the surface, boreholes, and underground workings.
2. Calibrate and relate the seismic propagation characteristics of the host rock to the fracture patterns observed in boreholes and underground workings, and to extrapolate the observed fracture patterns to the surrounding region.

Parameters

The parameters for this activity are travel time, amplitudes, and polarizations of the direct, reflected, and refracted compressional and shear waves (SH and SV), as well as other wave propagation characteristics identified by investigating the relationship of wave propagation characteristics to fracture properties.

Description

Tomographic vertical seismic profiling (VSP) techniques may be used to study the degree and character of fracturing of the rock mass. Feasibility studies will be performed to establish whether these techniques are applicable to the unsaturated zone at Yucca Mountain. If they are successful, then multi-offset, multisource (P, SV, and SH) VSP surveys would be conducted between the surface and existing drillholes, and between the surface and the underground excavations of the exploratory shaft facility, to detect and map spatial variation of fracture characteristics in the repository area. The objective will be to derive a series of maps of the fracture characteristics of the subsurface, to be used in development of a three-dimensional descriptive model of fracturing at Yucca Mountain. From previous VSP resolution studies, it is estimated that the spatial resolution for characterization of fracturing, in the VSP study areas at Yucca Mountain, could approach 20 m. The velocities, amplitudes, and polarizations of seismic phases recorded on three-component sensors may be used to infer fracture orientations, density, and spacing. Tomographic analysis using the travel times, amplitudes, and shear wave polarization may be used to relate seismic properties to the fracture properties. Three-component sensors will be placed in available boreholes with the compressional and shear wave sources placed at the surface. Surveys in boreholes will be calibrated by performing similar surveys in the shafts and underground workings where direct observations of fracture characteristics can be obtained. The hydrologic, geochemical, and geomechanical test results obtained in the exploratory shaft facility will be evaluated in terms of the fracture network and host-rock lithology information for the VSP surveys.

The combination of the surface geologic mapping, drillhole studies, and exploratory shaft geologic data combined with the fracture properties mapped from the VSP surveys will be used to construct a three-dimensional geologic

CONSULTATION DRAFT

framework for the entire repository. That is, the data gained from the VSP studies coupled with the geologic results will provide a means to extrapolate the exploratory shaft facility hydrologic, geochemical, geomechanical, and geophysical properties from specific sites (e.g., boreholes and underground workings) to the entire repository.

The following steps are proposed for the VSP work. First, structural and fracture domains with similar properties will be selected and defined in the exploratory shaft facility soon after each section of drift has been mapped. Second, appropriate sensors will be installed in drillholes into the shaft wall, providing a vertical array of sensors that can then be used to carry out the VSP work with the P- and S-wave sources at the surface. (A similar array of sensors also will be installed in the drift walls to allow additional ray path coverage.) Finally, after the instrumentation has been emplaced, the VSP survey will be conducted.

Laboratory analysis of core samples will be performed to observe and measure seismic propagation effects appropriate for interpreting the properties of the in situ rock mass. Fractured and unfractured specimens will be subjected to seismic excitation at test conditions (frequency, strain amplitude) representative of field test condition.

Methods and technical procedures

The methods and technical procedures for Activity 8.3.1.4.2.2.5 are given in the following table.

Method	Technical procedure		
	Number	Title	Date
Tomographic/vertical seismic profiling surveys using P- and S-wave data for fracture and structural mapping	TBD ^a	NNWSI Project vertical seismic profiling	TBD

^aTBD = to be determined.

8.3.1.4.2.3 Study: Three-dimensional geologic model

Objectives

The objective of this study is to develop a three-dimensional geologic model of the site area. In doing so, much of the study will involve synthesis of the results of other studies in the investigation to develop a model that will be integrated into the three-dimensional rock characteristics model described in Study 8.3.1.4.3.2 of Investigation 8.3.1.4.3.

CONSULTATION DRAFT

8.3.1.4.2.3.1 Activity: Development of a three-dimensional geologic model of the site area

Objectives

The objective of this activity is to develop a three-dimensional geologic model of the Yucca Mountain site that incorporates stratigraphic, structural, geophysical, and rock properties information pertinent to site characterization, and design and performance assessment activities.

Parameters

The parameters of this activity fall into three categories.

Stratigraphy-lithology (Lateral and vertical variations in lithostratigraphic units):

1. Depth.
2. Thickness.
3. Attitude.
4. Welding and crystallization.
5. Alteration.
6. Petrography.
7. Lithophysal zones in Topopah Spring Member.
8. Geophysical characteristics.

Faults:

1. Distribution.
2. Displacements.
3. Orientations.
4. Age relationships.
5. Physical features.
6. Geophysical characteristics.
7. Tectonic styles.

Fractures:

1. Spatial distribution.
2. Frequencies.
3. Trace lengths.
4. Orientations.
5. Age relationships.
6. Surface characteristics.
7. Interconnectedness.
8. Aperture.
9. Mineral filling.
10. Geophysical characteristics.

Description

Geologic data that are collected from coreholes, drillholes, outcrops, and geophysical studies will be used to construct isopach maps, structural contour maps, correlation diagrams, and cross sections. These illustrations

CONSULTATION DRAFT

will show the distribution and lithologic variability of stratigraphic units that underlie the site and surrounding areas such as Crater Flat and Jackass Flats. Principal scales of compilations will be 1:48,000, 1:24,000, and 1:12,000.

As stratigraphic, structural, and geophysical studies progress from data collection and documentation phases into interpretation phases, important sources of information will be reviewed, assessed, and integrated into a model that describes all relevant aspects of the site geology. This descriptive model will also incorporate geologic constraints discovered during development of models of the depositional and diagenetic histories of units.

Methods and technical procedures

The methods and technical procedures for Activity 8.3.1.4.2.3.1 are given in the following table.

Method	Technical procedure		
	Number	Title	Date
Synthesis of geologic and geophysical data	TBD ^a	Geologic synthesis	TBD

^aTBD = to be determined.

8.3.1.4.2.4 Application of results

The information derived from the studies and activities of the plans described previously will be used in the following areas of site characterization, repository design, and performance assessment:

The areas of performance assessment include the following:

<u>Issue or information need</u>	<u>Subject</u>
1.1.1	Site information needed to calculate the releases of radionuclides to the accessible environment (Section 8.3.5.13.1).
1.6.1	Site information and design information needed to identify the fastest path of likely radionuclide travel and to calculate the ground-water travel time along that path (Section 8.3.5.12.1)

CONSULTATION DRAFT

<u>Issue or information need</u>	<u>Subject</u>
1.8	NRC siting criteria (Section 8.3.5.17)
2.4.1	Site and design information required to support retrieval (Section 8.3.5.2.1).

The areas of design include the following:

<u>Issue or information need</u>	<u>Subject</u>
1.10.4	Description of the postemplacement near-field environment (Section 8.3.4.2.4).
1.11.3	Design concepts for orientation, geometry, layout, and depth of the underground facility that contribute to waste containment and isolation, including flexibility to accommodate site-specific conditions (Section 8.3.2.2.3).
1.11.6	Predicted thermal and thermomechanical response of the host rock, surrounding strata, and ground-water system (Section 8.3.2.2.6).
1.12.1	Site, waste package, and underground facility information needed for design of seals and their placement methods (Section 8.3.3.2.1).
2.7.1	Radiological protection (Section 8.3.2.3.1).
4.2.1	Site performance information needed for design (Section 8.3.2.4.1).
4.4.1	Site and performance information needed for design (Section 8.3.2.5.1).

The areas of characterization include the following:

<u>Investigation</u>	<u>Subject</u>
8.3.1.2.2	Description of the unsaturated zone hydrologic system at the site
8.3.1.2.3	Description of the saturated zone hydrologic system at the site
8.3.1.3.2	Mineralogy, petrology, and rock chemistry within the potential emplacement horizon and along potential flow paths
8.3.1.4.2	Geologic framework

CONSULTATION DRAFT

<u>Investigation</u>	<u>Subject</u>
8.3.1.4.3	Three-dimensional rock characteristics model
8.3.1.8.2	Tectonic effects on waste package
8.3.1.15.1	Spatial distribution of thermal and mechanical properties
8.3.1.15.2	Spatial distribution of ambient stress and thermal conditions
8.3.1.17.2	Potential fault movements at the site

8.3.1.4.2.5 Schedule and milestones

This investigation contains three studies: 8.3.1.4.2.1 (characterization of vertical and lateral distribution of stratigraphic units), 8.3.1.4.2.2 (characterization of structural features), and 8.3.1.4.2.3 (three-dimensional geologic model). In the figure that follows, the schedule information for these studies is presented in the form of timelines. The timelines extend from implementation of the approved study plans to the issuance of the final products associated with the studies. Summary schedule and milestone information for this investigation can be found in Section 8.5.1.1. Additional schedule information for exploratory shaft activities can be found in Section 8.5.1.2.

Completion of Studies 8.3.1.4.2.1 and 8.3.1.4.2.2 is partly constrained by the start of the exploratory shaft because some of their activities involve acquisition of data from the exploratory shaft. However, each of these studies also contains activities that can be performed separately from the exploratory shaft, and these can begin after the study plan is available. Studies 8.3.1.4.2.1 and 8.3.1.4.2.3 are expected to begin within the first year of site characterization.

The studies in this investigation will acquire and evaluate data on the nature and spatial variability of the stratigraphic and structural characteristics of the site. The studies will be conducted in parallel to obtain descriptive data and will interact in an iterative fashion to produce the final three-dimensional geologic model for use in the repository license application. The geologic model will contain representations of past and present geologic processes that pertain to the performance of the site.

The study numbers and titles corresponding to the timelines are shown on the left of the figure. The points shown on the timelines represent major events or important milestones associated with the study. Solid lines represent study durations, and dashed lines show interfaces.

CONSULTATION DRAFT

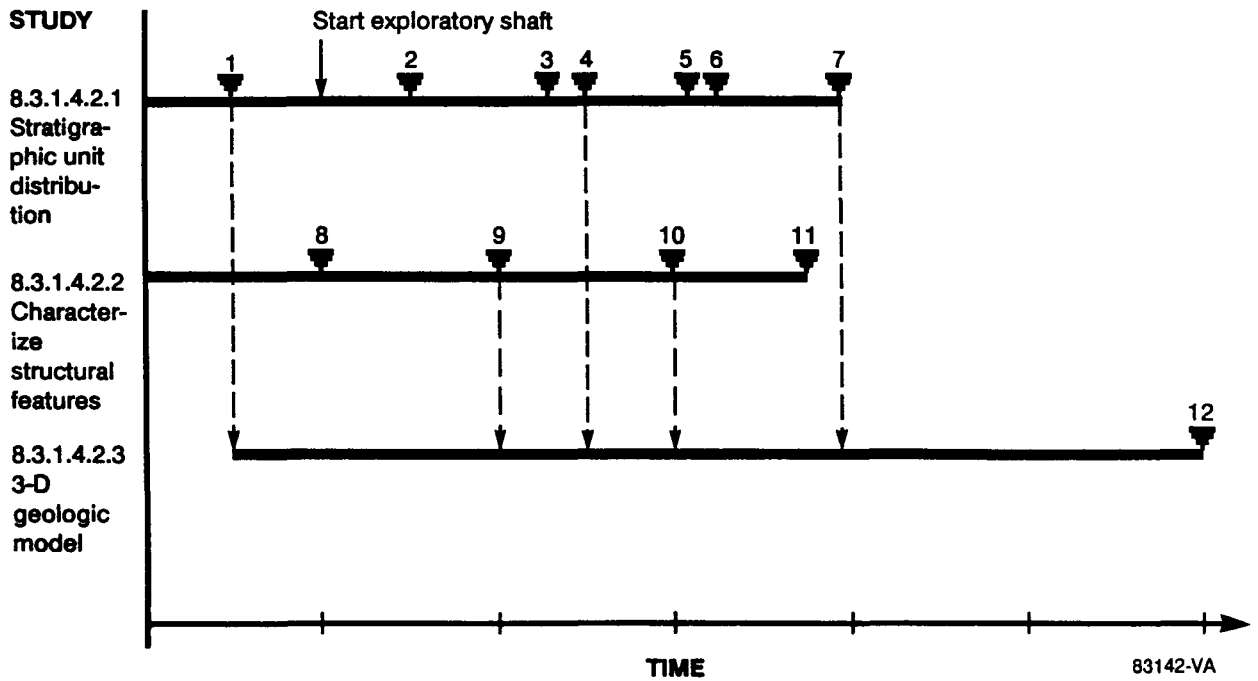

The points on the timeline are described in the following table:

<u>Point number</u>	<u>Description</u>
1	Milestone Q172. Decision whether to proceed with drillholes G-6 and G-7.
2	Milestone Z493. Complete preliminary geologic model of the site area.
3	Milestone P781. Issue report on lateral variation in stratigraphy.
4	Milestone M368. Issue report on preliminary site geologic description.
5	Milestone R757. Complete alteration and fracture mineralogy studies.
6	Milestone Q117. Complete drilling of geologic holes.
7	Issue report on compilation of structural and stratigraphic information from geologic holes.
8	Milestone P780. Issue final geologic map of Yucca Mountain.

CONSULTATION DRAFT

<u>Point number</u>	<u>Description</u>
9	Milestone Z263. Complete vertical seismic profiling studies.
10	Milestone Q009. Issue report on the characterization of structural features within the Yucca Mountain site area.
11	Milestone M624. Complete geologic map of the drift walls.
12	Milestone M384. Complete final 3-D geologic model of the site area.

8.3.1.4.3 Investigation: Development of three-dimensional models of rock characteristics at the repository site

Technical basis for obtaining the information

Link to technical data chapters and applicable support documents

The following sections summarize available data relevant to the development of three-dimensional models of rock characteristics for the repository area and the immediate vicinity.

<u>SCP section</u>	<u>Subject</u>
1.2.2.2	Cenozoic rocks (stratigraphy and lithology at Yucca Mountain)
1.3.2.2.2	Structures and structural history of Yucca Mountain
1.8.1.2	Stratigraphy and lithology (summary of significant results)
1.8.1.3	Structural geology and tectonics (summary of significant results)
1.8.2.1	Relation of geology to repository design
3.6.1	Hydrogeologic units
3.10.1	Summary of significant results (hydrogeology)
4.5	Summary of significant results (geochemistry)

Parameters

The principal result of this investigation will be the development of computer-based representations of the three-dimensional distribution of

CONSULTATION DRAFT

physical property data. Contour maps or cross sections will show the spatial distribution of such parameters as rock compressive strength, thermal conductivity, or gas permeability. Specific parameters to be modeled include those rock characteristics parameters requested as input to design or performance assessment information needs. As an intermediate step in the three-dimensional modeling process, this investigation will provide data such as porosity, saturated hydraulic conductivity, and saturation to provide a basis for defining the detailed spatial variability of the tuff rock mass upon which all rock characteristic distributions depend. Analysis of the core obtained by this study will also provide data pertaining to the following:

1. Location of geologic contacts.
2. Basic rock descriptions including degree of welding, types of pumice or lithic fragments, abundance of lithophysae, gross mineralogy, and alteration.
3. Subsurface characteristics of faults.
4. Fracture frequencies and orientation.
5. Rock quality designation.

The core will be available for more detailed examination of lithology, fractures, faults or other geologic features by other studies and investigations (particularly Investigation Section 8.3.1.4.2, geologic framework). As additional information from detailed study of core, geophysical logs, and other investigations becomes available, the three-dimensional model will be modified to reflect the new data.

Purpose and objectives of the investigation

The purpose of developing three-dimensional, computer-based models of rock characteristics at the Yucca Mountain site is two-fold: (1) to summarize information gained during the course of Investigations 8.3.1.4.2 (geologic framework), 8.3.1.2.1 through 8.3.1.2.3 (hydrologic material properties), 8.3.1.3.2 (geochemical material properties), and Program 8.3.1.15 (thermal/mechanical properties); and (2) to provide a mechanism for transfer of this integrated information to the design and performance assessment issues.

Specifically, performance assessment and design issues have called for quantitative information regarding the spatial distribution of various rock characteristics (Table 8.3.1.4-1). Numerous investigations have been designed to acquire the basic quantitative data or to develop the geologic framework that must be considered in the development of a three-dimensional model of rock characteristics.

Technical rationale for the investigation

This investigation consists of activities that integrate information collected by numerous other investigations. These diverse types of field and laboratory data are presented in the form of three-dimensional models of rock

CONSULTATION DRAFT

characteristics--models that have been requested by, and that will be utilized directly by, design and performance assessment studies.

Construction of a three-dimensional block model of rock properties that represents actual rock characteristics at the Yucca Mountain site is much more than the arbitrary "plugging" of quantitative values for some rock property into the proper "box" in 3-dimensional space. Interpolation algorithms are numerous, yet application of different procedures may yield vastly differing interpretations of identical input values. The critical factor for developing a model that is representative of in situ conditions is the extent to which the quantitative determinations of some rock property value are constrained by the geologic framework (Investigation 8.3.1.4.2) of the Yucca Mountain area. A porosity model that does not respect constraints imposed by geologic knowledge of the eruptive and depositional history of the rocks involved, the general vertical and lateral variability of similar rocks elsewhere, and the observed displacement of original rock units by faulting will not be generally accepted and therefore will not be useful to a performance assessment analyst or design engineer.

The essential philosophy of model development will be to use detailed information regarding the spatial structure of selected rock characteristics (e.g., porosity, saturated hydraulic conductivity) obtained by Study 8.3.1.4.3.1 (systematic drilling program) and less abundant, quantitative rock characteristics data obtained by Investigations 8.3.1.2.1 through 8.3.1.2.3, 8.3.1.3.2 and 8.3.1.15.1 in order to determine the spatial correlation structure of the rock characteristic(s) under current consideration. Quantitative descriptions of the identified spatial structure will be compared with descriptions of the geologic framework of Yucca Mountain (Investigation 8.3.1.4.2), and major discrepancies will be resolved. The quantitative descriptive data will then be interpolated and projected using a standard mathematical algorithm to create a model of the desired property(ies) as requested by performance assessment and design issues.

8.3.1.4.3.1 Study: Systematic acquisition of site-specific subsurface information

Only one activity is planned under this study.

8.3.1.4.3.1.1 Activity: Systematic drilling program

Objectives

This activity is an example of the type and scope of drilling programs that will be assessed in Investigation 8.3.1.4.1.

The objectives of this activity will be to acquire physical rock samples, analytical data and basic descriptions of the subsurface geology of the repository site on a systematic basis from which to determine the detailed, three-dimensional distribution of rock properties underlying Yucca Mountain. Data from this study are used principally in Programs 8.3.1.2

CONSULTATION DRAFT

(geohydrology), 8.3.1.3 (geochemistry), and 8.3.1.15 (thermal and mechanical rock properties) and Investigation 8.3.1.4.2 (geologic framework), which in turn provide essential data for Study 8.3.1.4.3.2 (three-dimensional rock characteristics models).

Description

The systematic drilling program that constitutes Study 8.3.1.4.3.1 is based upon the constraining requirement of data for input to the three-dimensional rock characteristics model (Study 8.3.1.4.3.2), which is systematic sampling and description of rock characteristics on a scale sufficiently detailed to allow quantitative characterization of the spatial variability. The appropriate sampling scale will depend upon the parameter of interest. Determination of adequate characterization of spatial variability will depend heavily upon geostatistical techniques and will be identified in close cooperation with the modeling efforts of Study 8.3.1.4.3.2. Stratigraphic and structural data from this study will be analyzed by Investigation 8.3.1.4.2 (geologic framework).

The data requirements specified by Study 8.3.1.4.3.2 (rock characteristics model) indicate that representative sampling of the repository site should be systematic in both horizontal and vertical dimensions. In support of this requirement, this activity proposes to drill up to 40 continuously cored holes and will provide for the basic geologic description and physical sampling of that core. The actual number and location of these holes will be determined at a later date as the drilling program matures, as described in Investigation 8.3.1.4.1. This study will also provide determinations of a small suite of parameter values (porosity, saturated hydraulic conductivity, saturation) for samples taken from this core in order to determine the spatial variability of the volcanic rock mass in detail. The logic behind this approach is that the basic spatial correlation data to be obtained are correlated statistically to the spatial distribution of other rock characteristics because these other parameters of interest are derived from the same physical rock mass. The essential correlation structure of the rock mass can be used to interpolate between more isolated data points determined through other investigations, including

1. Hydrologic properties (Investigations 8.3.1.2.1 through 8.3.1.2.3).
2. Thermal parameters (Investigation 8.3.1.15.1).
3. Mechanical parameters (Investigation 8.3.1.15.1).
4. Geochemical parameters (Investigations 8.3.1.3.2 through 8.3.1.3.3).

Holes will be located on a grid pattern (with allowance for topography, existing or other proposed site-characterization holes, the exploratory shaft drifts, etc.). The drilling program will be conducted in successive phases, allowing for evaluation of the data collected from each phase before continuing with the next stage. Information gained during each phase may, and probably will, result in a revised plan for the succeeding phase. The actual timing, locations, and phasing of these drillholes will be subject to the results of Investigation 8.3.1.4.1 (development of the integrated drilling program).

Theoretically, the first phase of drilling might consist of about 12 continuous core holes located of a grid of nominal dimensions 3,500 ft by

CONSULTATION DRAFT

4,200 ft (Figure 8.3.1.4-12), which covers the entire repository area including areas proposed for extensions. Holes will be drilled to approximately 200 ft below the static water table. The second phase of drilling, if undertaken, might consist of 12 additional continuous coreholes generally located half-way between the holes of the first phase to produce a grid with nominal dimensions of 2,700 by 2,700 ft (Figure 8.3.1.4-13). Several holes may be located at closer intervals in order to provide information on small-scale variability (order of 1,000 ft). Locations of holes for a third phase of drilling are more speculative, but options include completing the remaining 2,700-ft nominal grid locations or focusing on the current repository site and completing a local grid with nominal spacing of 1,750 by 2,100 ft. Both of these options can be tailored to look at specific plans, such as expansion of the presently planned repository, or investigating specific questions that arise during performance confirmation (Figure 8.3.1.4-13). Most holes will be vertical. However, several holes angled approximately minus-60-degrees to the west may be drilled.

The sampling program will be designed to obtain statistically representative measurements of porosity, saturated hydraulic conductivity, and saturation in order to define the basic spatial variability of the rock mass (this study). After measurements of porosity, saturation, and hydraulic conductivity are completed, these samples (and other samples on an as-requested basis) will be analyzed for additional rock characteristics to support the programs in geohydrology (Program 8.3.1.2), rock characteristics (Program 8.3.1.4), and geochemistry (Program 8.3.1.3). Determination of parameters that require destructive testing will be performed last. The process of determining multiple rock properties for the same physical piece of material will form much of the basis for correlating rock characteristics data.

Figure 8.3.1.4-14 summarizes in a conceptual manner a possible method of coordinating the multiple sampling efforts for the same core segment. The actual mechanism eventually used by the Project will be determined by Project needs and coordinated through the drilling integration group (Investigation 8.3.1.4.1) and the sample overview committee.

The sampling program for sample group A (sampled for porosity, hydraulic conductivity, and saturation) is predetermined and is carried out automatically by the Sample Management Facility. Porosity and saturation are determined on samples collected every 5 ft; saturated hydraulic conductivity would be determined on every other sample, or every 10 ft. A secondary sampling program would be conducted in at least two locations within each stratigraphic unit to ensure that close-order variability is adequately represented. This secondary sampling program is represented schematically on the left-hand side of Figure 8.3.1.4-14.

Sample Group B (Figure 8.3.1.4-14) may be collected to define other rock characteristics parameters under other investigations that do not call for the same level of detail as those characteristics in Sample Group A. Sample Group C (Figure 8.3.1.4-14), would be collected for an investigation that requires a different sampling density. Sample Group D (Figure 8.3.1.4-14) represents yet a third study that obtains core samples from the systematic drilling program. Each of these sampling programs, A, B, C, and D, would be predetermined and will take place automatically. In this manner, the

CONSULTATION DRAFT

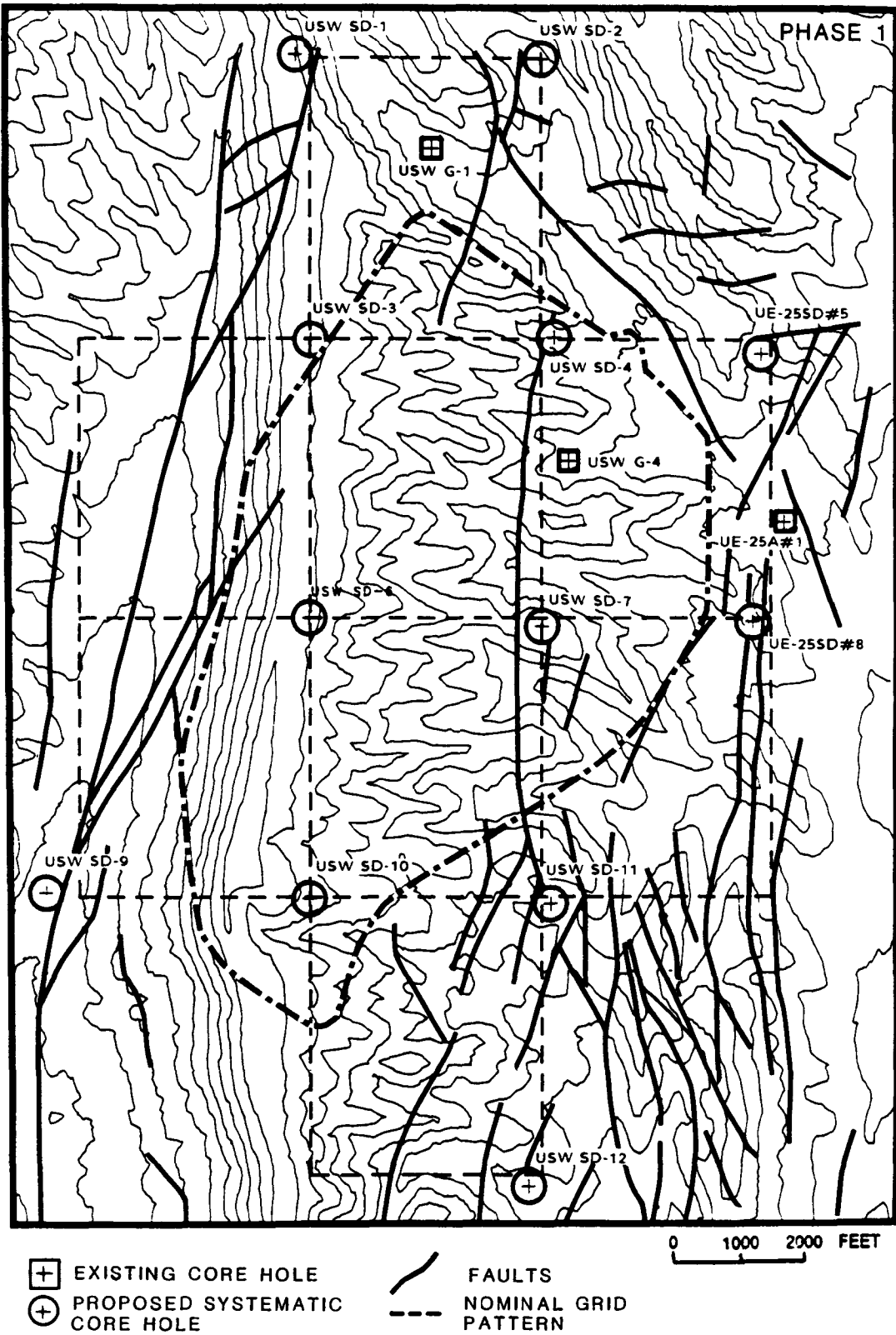
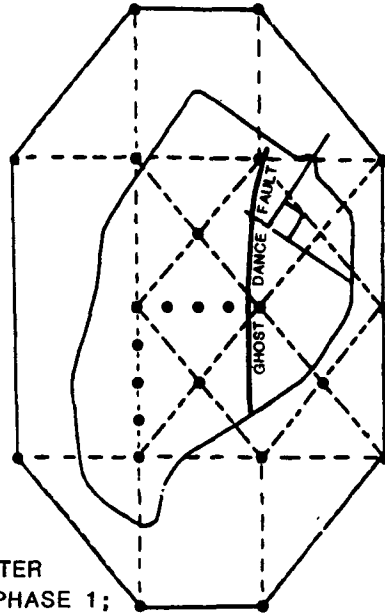
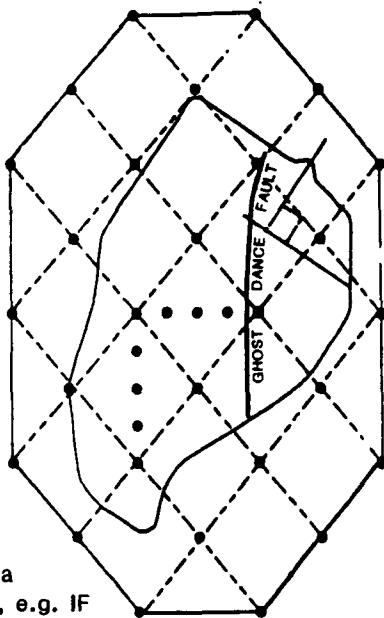

Figure 8.3.1.4-12. Distribution of proposed core holes for the first phase of systematic coring

CONSULTATION DRAFT



PHASE 2
(DESIGNED AFTER
ANALYSIS OF PHASE 1;
e.g. THIS OPTION YIELDS
SMALLER-SCALE VARIABILITY
IN FACILITY AREA)



PHASE 3a
(OPTION, e.g. IF
FACILITY EXPANSION
IS REQUIRED)

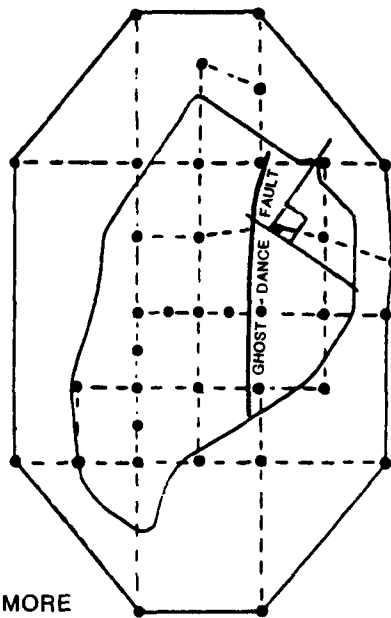

PHASE 3b
(OPTION, e.g. MORE
DETAIL REQUIRED ALONG
UNSATURATED ZONE
FLOWPATH OR IN HOST ROCK)

Figure 8.3.1.4-13. Conceptual example of additional phased systematic coring.

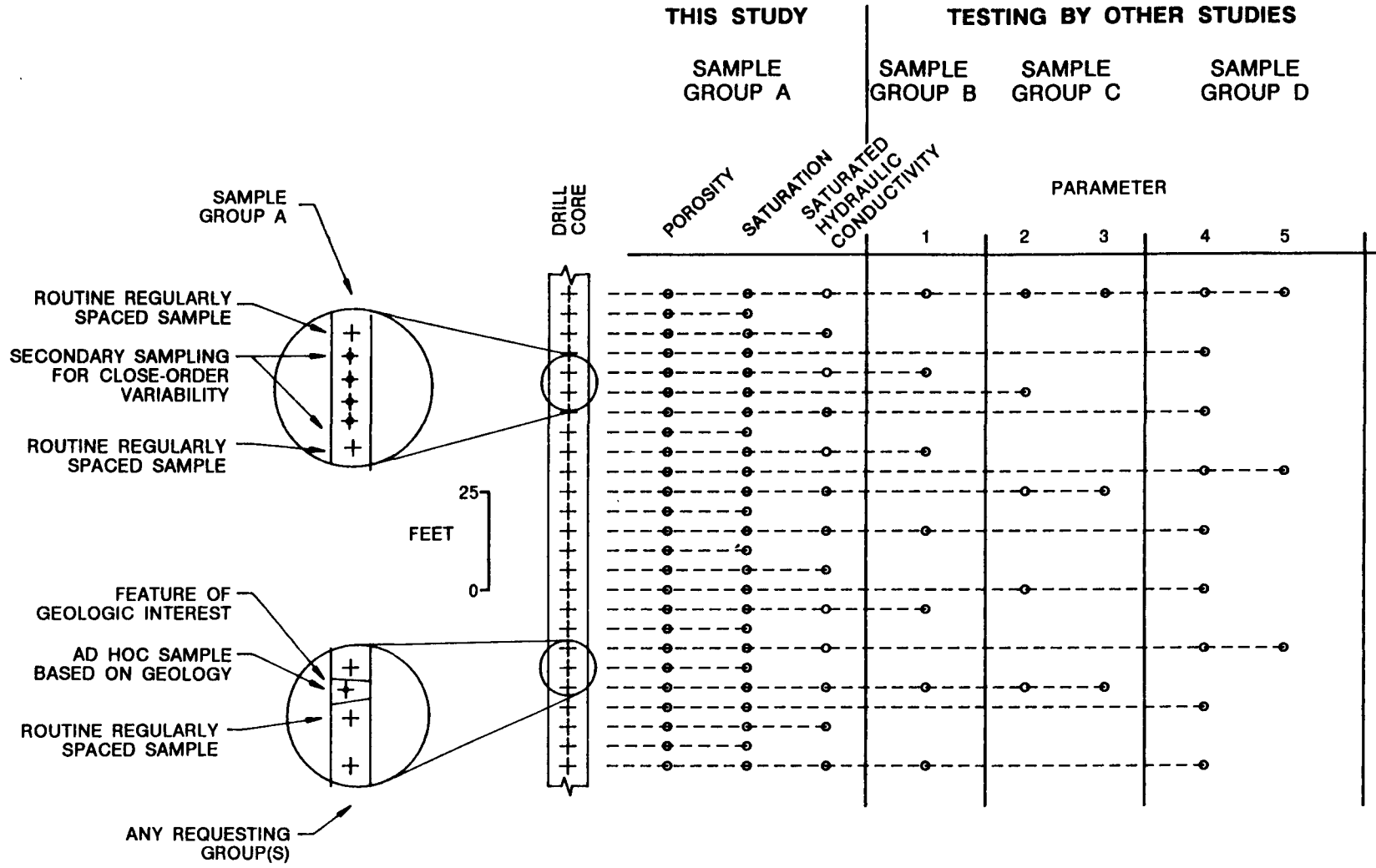

Figure 8.3.1.4-14. Possible systematic sampling program.

CONSULTATION DRAFT

systematic drilling (and sampling) program would provide both for samples that are relatively unbiased and representative of the bulk rock mass and for samples of anomalies or features of interest that may occur only locally.

Methods and technical procedures

The methods and technical procedures for Activity 8.3.1.4.3.1.1 are given in the following table.

Method	Number	Technical procedure	
		Title	Date
Drilling and coring	TBD ^a	Drilling and coring	TBD
Graphic logging	TBD	Graphic logging of drill core	TBD
Drillhole sampling	TBD	Routine sampling of drillholes	TBD
Sample identification, handling, and storage	TBD	Sample tracking	TBD

^aTBD = to be determined.

8.3.1.4.3.2 Study: Three-dimensional rock characteristics models

8.3.1.4.3.2.1 Activity: Development of three-dimensional models of rock characteristics at the repository site

Objectives

The objective of this activity is to develop computer-based three-dimensional models that integrate quantitative and semiquantitative data on rock characteristics in light of constraining information developed by studies of the geologic framework of the Yucca Mountain site (Investigation 8.3.1.4.2).

Description

This study will serve as the process whereby the majority of location-specific site characterization data describing rock characteristics is summarized and interpreted in light of a constraining geologic framework (Investigation 8.3.1.4.2) for Yucca Mountain. This study also will result in

CONSULTATION DRAFT

models that will be the means by which these data pass from site characterization investigations to design and performance assessment studies. Because the rock characteristics data and the geologic framework information both will be represented as three-dimensional computer-based models that are closely linked to the NNWSI Project Technical Data Base, representations of the model may take many forms depending upon the use to which the information will be put. For example, information from the model may be represented on contour (isopleth) maps, cross sections, level plans, "3-D" perspective illustrations, statistical distributions (histograms, means, variances), and as numerical data files for direct input to computer codes used for performance assessment or design analyses. The primary requirement of input data for the three-dimensional rock property models is systematic and statistically valid (unbiased) sampling at scales adequate to allow quantitative characterization of the spatial variability of the parameters of interest at Yucca Mountain. Characterization of spatial variability will depend heavily upon geostatistical techniques. Determination of sampling intervals and parameters will rely upon geostatistical analysis in conjunction with sensitivity studies conducted by the associated performance assessment or design information needs.

Much of the analysis of the spatial variability will depend upon detailed knowledge of a few selected rock characteristics (e.g., porosity, saturated hydraulic conductivity, saturation) that will be obtained as part of the integrated drilling program described by Investigation 8.3.1.4.1. These parameters will serve as surrogates in determining the spatial variability of several other parameters needed by performance assessment and design issues in preliminary stages of the analyses. Because the basic spatial distribution of properties of the rock mass at Yucca Mountain is that produced by the processes of volcanic eruption, transport, deposition, and post-depositional alteration (including welding and devitrification), the quantitative description of the distribution should correspond to parameters that derive their distribution from some part of those emplacement and alteration processes.

The measured values of parameters from which the final modeling activities will be conducted, will come largely from Site Programs 8.3.1.2 (geohydrology), 8.3.1.3 (geochemistry), and 8.3.1.15 (thermal and mechanical properties).

The models typically will be constructed as follows. First, measured values of the hydrogeologic, geochemical, or thermal/mechanical parameters of interest (from drillholes and the exploratory shaft facilities) will be mapped into their proper three-dimensional location in model space. Second, geologic framework information (the altitude of geologic contacts, fault locations and offsets, etc.), from Investigation 8.3.1.4.2 also will be mapped into three-dimensional model space. The spatial structure of the observed values (actual measurements) will be determined by geostatistical techniques (variogram or covariance analysis). The spatial structure of a group of related parameters may be further refined by study of the cross-covariances among those quantities. Conflicts between the observed spatial structure of quantitative data and the structure implied by the geologic framework will be resolved (for example, identification of a concealed fault, reinterpretation of volcanic source area or flow path, or identification of some previously unknown alteration phenomenon). Surface-based and borehole

CONSULTATION DRAFT

geophysical interpretations will also provide a constraint upon subsurface modeling. The geostatistical techniques of covariance analysis and kriging will be used to determine when the spatial structure of a parameter of interest is sufficient.

Hydrologic, thermal/mechanical, and geochemical rock property measurements then will be interpolated into unsampled areas constrained by the observed values at sampling points, by the faulted stratigraphy, and by the identified spatial structure. The most detailed approach to this phase of modeling involves the formulation of a three-dimensional block model, wherein the site is divided into numerous orthogonal blocks and each block is sufficiently small that the parameter of interest maybe treated as constant within the block. Once the structure of the data is determined, the values of unsampled blocks are estimated (interpolated) by kriging (or cokriging). Geostatistical techniques provide estimates of the uncertainty associated with each parameter within each block. Estimates of the probability that the true value in each block exceeds some predetermined limit or is within some range of values (specified by the corresponding performance assessment or design issue) are also possible. Geostatistics also attempts to address the question of variability of observed values for a parameter in terms of support, or the volume of material in which a determination of a parameter is made.

Methods and technical procedures

To be determined.

8.3.1.4.3.3 Application of results

The models and associated uncertainty information derived from this investigation will be used in the following areas of performance assessment and design.

The areas of performance assessment include the following:

<u>Issue or information need</u>	<u>Subject</u>
1.1.1	Site information needed to calculate the releases of radionuclides to the accessible environment (Section 8.3.5.13.1).
1.6.1	Site information and design information needed to identify the fastest path of likely radionuclide travel and to calculate the ground-water travel time along that path (Section 8.3.5.12.1).
1.8	NRC siting criteria (Section 8.3.5.17).
2.4.1	Site and design data required to support retrieval (Section 8.3.5.2.1).

CONSULTATION DRAFT

The areas of design include the following:

<u>Issue or information need</u>	<u>Subject</u>
1.10.4	Near-field environment (Section 8.3.4.2.4).
1.11.1	Site characteristics needed for design (Section 8.3.2.2.1).
1.12.1	Information needed for seal design and placement (Section 8.3.3.2.1).
2.7.1	Radiological protection (Section 8.3.2.3.1).
4.2.1	Site performance information needed for design (Section 8.3.2.4.1).
4.4.1	Site and performance information needed for design (Section 8.3.2.5.1).

8.3.1.4.3.4 Schedule and milestones

This investigation, addressing three-dimensional rock characteristics models, contains two out-year studies: 8.3.1.4.3.1 (systematic acquisition of site-specific subsurface information) and 8.3.1.4.3.2 (three-dimensional rock characteristics models). In the figure that follows, the schedule information for these studies is presented in the form of timelines. The timelines extend from implementation of the approved study plans to the issuance of the final products associated with the studies. Summary schedule and milestone information for this investigation can be found in Section 8.5.1.1.

Study 8.3.1.4.3.1 involves systematic drilling, sampling, logging, and compilation of the rock characteristics data that result from sample testing. The three-dimensional rock characteristics model of Study 8.3.1.4.3.2 will be used in design and performance assessment for the repository license application. Initiation of drilling for this study is contingent on the results from drilling integration in Study 8.3.1.4.1.3, as indicated on the figure. Successive phases of drilling are possible based on reevaluation of accumulated data and are also constrained by the results from drilling integration.

The study numbers and titles corresponding to the timelines are shown on the left of the following figure. The points shown on the timelines represent major events or important milestones associated with the study. Solid lines represent study durations, and dashed lines show interfaces. The data input and output at the interfaces are shown by circles.

CONSULTATION DRAFT

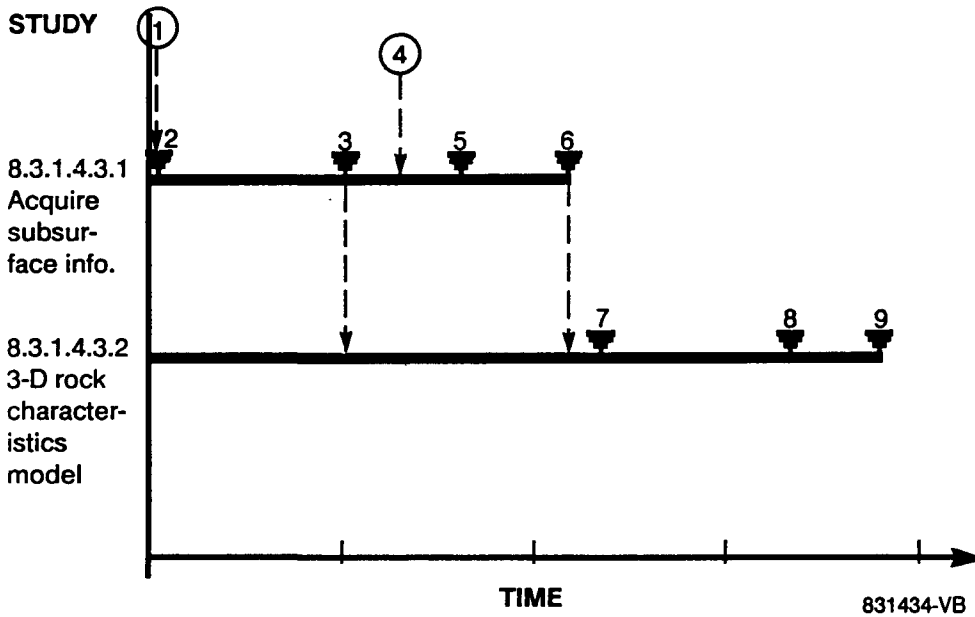

The points on the timeline and the data input and output at the interfaces are described in the following table:

<u>Point number</u>	<u>Description</u>
1	Input from integrated drilling plan for second year of site characterization (Study 8.3.1.4.1.3).
2	Milestone Q093. Begin Phase I of systematic site drilling (representative sampling) program.
3	Milestone Q101. Complete Phase I of systematic site drilling program.
4	Input from integrated drilling plan for third year of site characterization (Study 8.3.1.4.1.3).
5	Milestone Q102. Begin Phase II of systematic site drilling (representative sampling) program.
6	Milestone Q118. Complete Phase II of systematic site drilling program.
7	Milestone Z434. Issue reference model for 3-D rock characteristics of Yucca Mountain, to support advanced conceptual design.
8	Milestone Z436. Complete compilation of systematic drilling data for support of license application design.

CONSULTATION DRAFT

Point
number

Description

9 Milestone Q006. Complete final reference model for 3-D rock characteristics of Yucca Mountain.

Nuclear Waste Policy Act
(Section 113)

Section 8.3.1.5

Consultation Draft

CLIMATE



Site Characterization Plan

***Yucca Mountain Site, Nevada Research
and Development Area, Nevada***

Volume V

January 1988

U.S. Department of Energy
Office of Civilian Radioactive Waste Management
Washington, DC 20585

CONSULTATION DRAFT

8.3.1.5 Overview of the climate program: Description of future climate conditions, required by the performance and design issues

Summary of performance and design requirements for climate information

Certain performance and design issues address requirements that climate and climate-related factors be determined for past, present, and future conditions (Investigation 8.3.1.5.1) and that the effects of future climate on hydrology be determined (Investigation 8.3.1.5.2). The results of Investigation 8.3.1.5.1 are necessary inputs to Investigation 8.3.1.5.2. Pertinent available data on recent climate, meteorology, and paleoclimate are presented in Chapter 5 along with a discussion of methods for predicting future climate. Similarly, available hydrology data pertinent to Yucca Mountain are presented in Chapter 3. The general conclusions from Chapters 3 and 5 are that more data are required than are presently available on the paleohydrology, paleoclimate, and modern climate of the Yucca Mountain area in order to adequately predict future climate and its possible effect on site hydrology relative to repository performance.

Plans for two investigations making up the climate program are given in Sections 8.3.1.5.1 and 8.3.1.5.2. Other plans for site investigations requiring climate information include those for the erosion program (Section 8.3.1.6), the geochemistry program (Section 8.3.1.3), the preclosure hydrology program (Section 8.3.1.16), and the geohydrology program (Section 8.3.1.2). The relationship between the climate program and the design and performance issues is shown in Figure 8.3.1.5-1.

The climate program consists of investigations designed to provide data on past, present, and future climate conditions and to determine the effects of climate change on surface, unsaturated-zone, and saturated-zone hydrology. Specifically, determining the effects of future climate on geohydrology helps to satisfy the following performance and design issues.

<u>Issue</u>	<u>Short title</u>	<u>SCP section</u>
1.1	Total system performance (the system performance objective for limiting radionuclide releases to the accessible environment as required by 10 CFR Part 60 and 40 CFR 191.13)	8.3.5.13
1.8	NRC siting criteria (the favorable and potentially adverse conditions of 10 CFR Part 60)	8.3.5.17
1.9a	Higher level findings (postclosure) of 10 CFR Part 960: (1) 960.4-2-1, qualifying condition for geohydrology, (2) 960.4-2-4, qualifying condition for climate	8.3.5.18

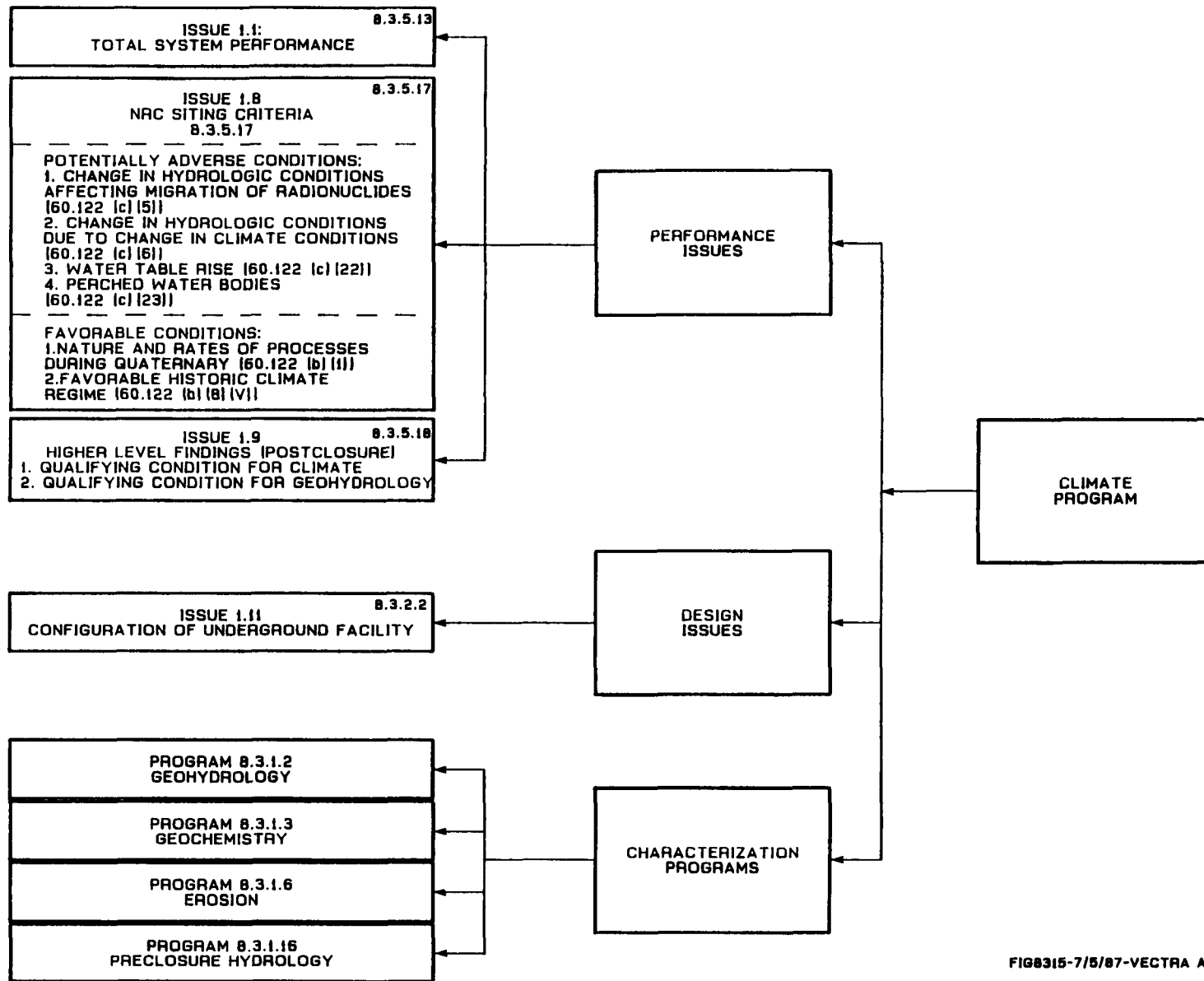

FIG8315-7/5/87-VECTRA A

Figure 8.3.1.5-1. General logic diagram showing ties between climate program and other characterization programs, design issues, and performance issues.

CONSULTATION DRAFT

<u>Issue</u>	<u>Short title</u>	<u>SCP section</u>
1.9b	Comparative evaluation over next 100,000 yr	8.3.5.18
1.10	Waste package characteristics (postclosure)	8.3.4.2
1.11	Configuration of underground facilities (postclosure)	8.3.2.2
1.12	Seal characteristics	8.3.3.2

For the 10,000-yr period (Issues 1.1, 1.8, 1.9a, 1.10, 1.11, and 1.12), it has been determined that information needed to satisfy Issue 1.1 will be sufficient to address Issues 1.8, 1.9a, 1.10, 1.11, and 1.12. However, to satisfy Issue 1.9b (the comparative evaluation over the next 100,000 yr), additional information is required within the climate program, including additional data and slightly different modeling strategies (Section 8.3.1.5.1.6.2).

Table 8.3.1.5-1 lists the specific repository performance scenarios related to climatic change in the "initiating event or process" column. These scenarios have been identified as being of concern to Issues 1.1 and 1.9b. Each scenario has a related performance measure, as shown in column 2. Each performance measure has two performance parameters in the third column, related to either the 10,000-yr or 100,000-yr period. Each performance measure has an additional parameter assigned as the quantitative bound on the expected magnitude of the performance parameter. Following the performance parameters are the tentative goals and corresponding confidence levels needed to meet the total system performance objectives.

The primary climatic variables that have an effect on the performance measures include magnitude and intensity of precipitation, storm types as they influence initial runoff and snow accumulation, and snowmelt and evapotranspiration. The relationship between the performance parameters and the related climate investigations is presented in the next section.

Approach to satisfy performance and design requirements

The investigations, studies, and activities within the climate program are designed to provide estimates of future climatic conditions and estimates of the effects of future climate on hydrologic conditions. Figure 8.3.1.5-2 traces the flow of information to show how data-gathering activities lead to modeling and synthesis activities to finally result in a determination of the effects of future climate on unsaturated-zone, saturated-zone, and surface-water hydrology to satisfy Performance Issues 1.1 and 1.9b (and subsequently Issues 1.8, 1.10, 1.11, and 1.12) as discussed in the previous section. This figure ties into Table 8.3.1.5-2.

Table 8.3.1.5-1. Initiating events or processes and associated performance measures (for climate program) (page 1 of 2)

Initiating event or process	Intermediate performance measures	Performance parameters	Tentative goal	Needed confidence
Climatic changes cause increase in infiltration over C-area ^a	Radionuclide transport time through UZ ^b , given fixed UZ thickness, rock hydrologic properties, and geochemical properties	Expected magnitude of flux change due to climatic changes over next 10,000 yr (to satisfy Issue 1.1)	Show expected flux change will be < 5 mm/yr	High
		Expected magnitude of flux change due to climatic changes over 100,000 yr (to satisfy Issue 1.9b)	Show expected flux change will be < 5 mm/yr	High
Climatic changes cause an increase in altitude of water table	Radionuclide transport time through UZ, given fixed UZ rock hydrologic and geochemical properties	Expected magnitude of change in water-table level due to climatic changes over next 10,000 yr (to satisfy Issue 1.1)	Show expected magnitude of change in water-table altitude will be <+100 m	High
		Expected magnitude of change in water-table level due to climatic changes over next 100,000 yr (to satisfy Issue 1.9b)	Show expected magnitude of change in water-table altitude will be <+100 m	Moderate
Climatic change causes an increase in the gradient of the water table within the C-area	Radionuclide transport time through SZ ^c , given fixed distances to accessible environment boundary	Expected magnitude of change in water-table gradient due to climatic change over the next 10,000 yr (to satisfy Issue 1.1)	Show change will be < 2 x 10 ⁻³	Moderate

8.3.1.5-4

CONSULTATION DRAFT

Table 8.3.1.5 1. Initiating events or processes and associated performance measures (for climate program) (page 2 of 2)

Initiating event or process	Intermediate performance measures	Performance parameters	Tentative goal	Needed confidence
		Expected magnitude of change in water-table gradient due to climatic change over next 100,000 yr (to satisfy Issue 1.9b)	Show change _s will be $< 2 \times 10^3$	Moderate
Climatic change causes appearance of surficial discharge points within C-area	Radionuclide transport time through SZ, given fixed SZ rock hydrologic and geochemical properties	Expected locations of surficial discharge points within C-zone over the next 10,000 yr; magnitudes of discharges at each location (to satisfy Issue 1.1)	Show that no significant surficial discharge points could appear within C-area, given a water-table rise $< +160$ m	Moderate
		Expected locations of surficial discharge points within the C-zone due to climatic change over the next 100,000 yr (to satisfy Issue 1.9b)	Show that no significant surficial discharge points could appear within C-area, given a water-table rise $< +160$ m	Moderate

^aC-area = controlled area.

^bUZ = unsaturated zone.

^cSZ = saturated zone.

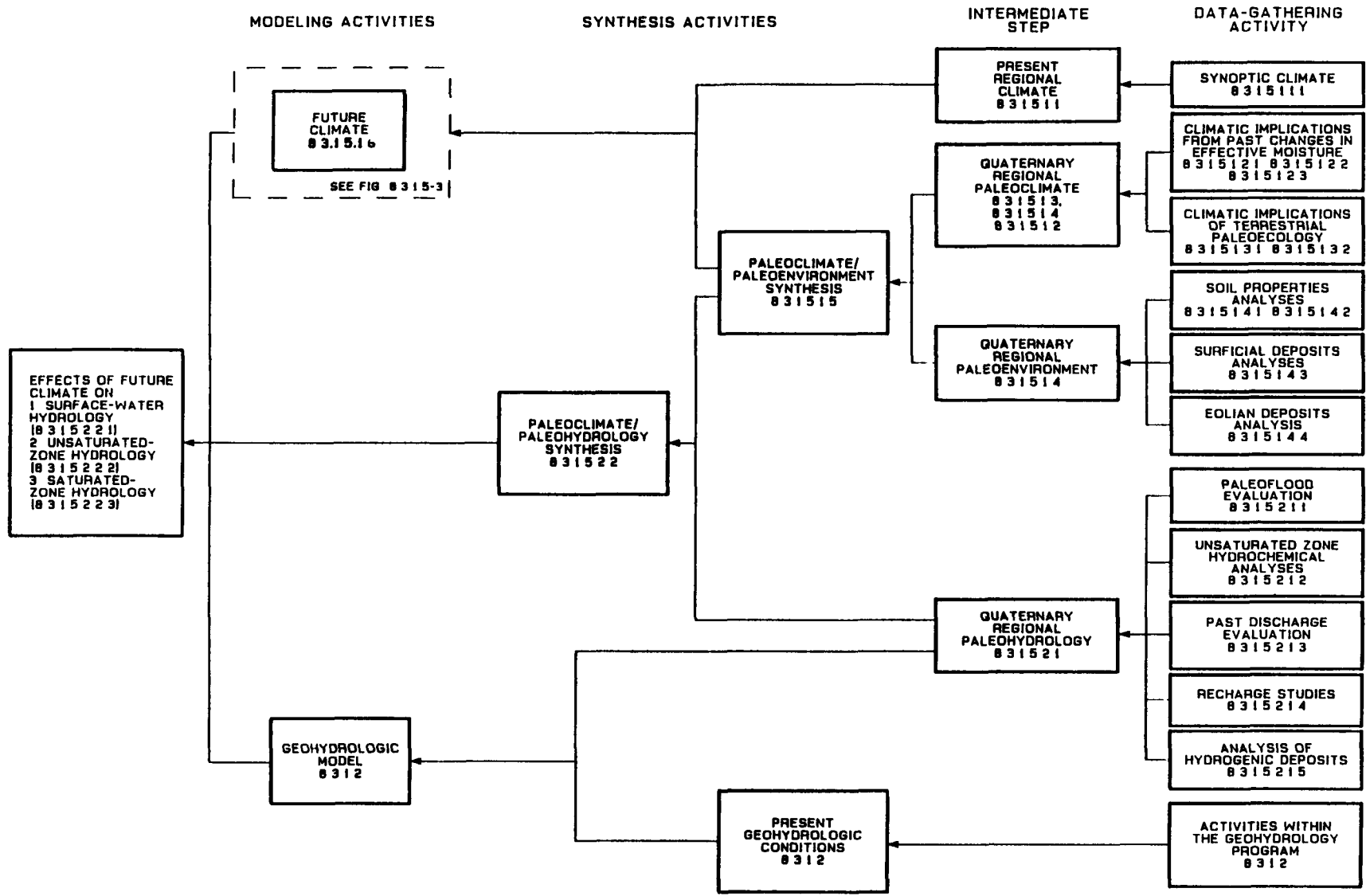

Figure 8.3.1.5-2. Logic diagram for climate program

Table 8.3.1.5-2. Activity parameters provided by the climate program that support performance and design issues (page 1 of 6)

Calls by performance and design issues		Parameter category	Response by climate characterization program	
Issue	SCP section		Activity parameter	SCP activity
1.1, 1.9.1	8.3.5.13, 8.3.5.18.1	Present regional climate	Monthly and annual values for temperature	8.3.1.5.1.1.1
			Monthly and annual values for precipitation	8.3.1.5.1.1.1
			Monthly and annual values for wind-velocity	8.3.1.5.1.1.1
			Spatial and temporal variation of precipitation	8.3.1.5.1.1.1
			Spatial and temporal variation of air temperature	8.3.1.5.1.1.1
1.1, 1.9.1	8.3.5.13, 8.3.5.18.1	Quaternary regional paleoclimate	Paleontology (ostracodes, diatoms, aquatic polynomorphs, etc.) in marsh, lake and playa deposits	8.3.1.5.1.2.1
			Lithostratigraphy of marsh, lake and playa deposits	8.3.1.5.1.2.2
			Clastic sedimentology of marsh, lake and playa deposits	8.3.1.5.1.2.2
			Chemical sedimentology of marsh, lake and playa deposits	8.3.1.5.1.2.2
			Major element analyses of bulk sediments from marsh, lakes and playas	8.3.1.5.1.2.2
			Carbonate mineralogy of bulk sediments from lakes, marshes, and playas	8.3.1.5.1.2.3

8.3.1.5-7

CONSULTATION DRAFT

Table 8.3.1.5-2.

Activity parameters provided by the climate program that support performance and design issues (page 2 of 6)

Calls by performance and design issues		Parameter category	Response by climate characterization program	
Issue	SCP section		Activity parameter	SCP activity
1.1, 1.9.1 (continued)	8.3.5.13, 8.3.5.18.1 (continued)	Quaternary regional paleoclimate (continued)	Non-carbonate mineralogy of bulk sediments from lakes, playas, and marshes	8.3.1.5.1.2.3
			Stable isotope analyses of bulk sediments from lakes, playas, and marshes	8.3.1.5.1.2.3
			Ages of playa, lake and marsh deposits	8.3.1.5.1.2.4
			Packrat midden compositions	8.3.1.5.1.3.1
			Packrat midden distributions	8.3.1.5.1.3.1
			Packrat midden ages	8.3.1.5.1.3.1
			Pollen and spore compositions	8.3.1.5.1.3.2
			Pollen and spore distributions	8.3.1.5.1.3.2
			Pollen and spore ages	8.3.1.5.1.3.2
			Pollen-climate transfer functions	8.3.1.5.1.3.3
			Vegetation-climate and pollen-climate response surfaces	8.3.1.5.1.3.3
			Soil morphology and distribution	8.3.1.5.1.4.1
			Soil physical properties	8.3.1.5.1.4.1, 8.3.1.5.1.4.2
			Soil chemical properties	8.3.1.5.1.4.1, 8.3.1.5.1.4.2

8.3.1.5-8

CONSULTATION DRAFT

Table 8.3.1.5-2. Activity parameters provided by the climate program that support performance and design issues (page 3 of 6)

Calls by performance and design issues		Parameter category	Response by climate characterization program	
Issue	SCP section		Activity parameter	SCP activity
1.1, 1.9.1 (continued)	8.3.5.13, 8.3.5.18.1 (continued)	Quaternary regional paleoclimate (continued)	Dust physical properties	8.3.1.5.1.4.1
			Dust chemical properties	8.3.1.5.1.4.1
			Soil water holding capacity	8.3.1.5.1.4.1
			Soil partial pressure of CO ₂	8.3.1.5.1.4.1
			Movement of soil solutions ²	8.3.1.5.1.4.1
			Rates of carbonate translocation in soils	8.3.1.5.1.4.1
			Ages of soils	8.3.1.5.1.4.1
			Physical properties of surficial deposits	8.3.1.5.1.4.2, 8.3.1.5.1.4.3
			Soil mineralogical properties	8.3.1.5.1.4.2
			Ages of surficial deposits	8.3.1.5.1.4.2, 8.3.1.5.1.4.3
			Soil water chemistry	8.3.1.5.1.4.2
			Distribution of surficial deposits	8.3.1.5.1.4.3
			Thickness of surficial deposits	8.3.1.5.1.4.3
			Chemical properties of surficial deposits	8.3.1.5.1.4.3
			Mineralogical properties of surficial deposits	8.3.1.5.1.4.3
			Ages of Eolian deposits	8.3.1.5.1.4.4
			Trace element geochemicals in Eolian deposits	8.3.1.5.1.4.4
			Trace element in alluvium paleo- wind velocity	8.3.1.5.1.4.4

8.3.1.5-9

CONSULTATION DRAFT

Table 8.3.1.5-2. Activity parameters provided by the climate program that support performance and design issues (page 4 of 6)

Calls by performance and design issues		Parameter category	Response by climate characterization program	
Issue	SCP section		Activity parameter	SCP activity
1.1, 1.9.1	8.3.5.13, 8.3.5.18.1	Paleoclimate paleoenvironmental synthesis	Paleoprecipitation distributions	8.3.1.5.1.5.1
			Paleoprecipitation intensities	8.3.1.5.1.5.1
			Paleotemperature patterns	8.3.1.5.1.5.1
			Paleoevaporation rates	8.3.1.5.1.5.1
			Time series of paleoprecipitation at key locations	8.3.1.5.1.5.1
			Time series of paleoevaporation rates at key locations	8.3.1.5.1.5.1
			Time series of paleotemperature at key locations	8.3.1.5.1.5.1
			Magnitude of high paleoprecipitation	8.3.1.5.1.5.1
			Duration of high paleoprecipitation periods	8.3.1.5.1.5.1
			Occurrence of high paleosnowmelt	8.3.1.5.1.5.1
			Magnitude of low paleotemperatures	8.3.1.5.1.5.1
Magnitude of low paleoevaporation	8.3.1.5.1.5.1			
1.1, 1.9.1	8.3.5.13, 8.3.5.18.1	Future climate	Future seasonal distribution and average annual rainfall	8.3.1.5.1.6.4
			Future type and intensity of storms	8.3.1.5.1.6.4
			Future distribution and average annual snowfall and rapidity of snowmelt	8.3.1.5.1.6.4
			Future evapotranspiration	8.3.1.5.1.6.4
			Future cloud cover	8.3.1.5.1.6.4
			Future temperature	8.3.1.5.1.6.4
			Future wind speed and direction	8.3.1.5.1.6.4

8.3.1.5-10

CONSULTATION DRAFT

Table 8.3.1.5-2. Activity parameters provided by the climate program that support performance and design issues (page 5 of 6)

Calls by performance and design issues		Parameter category	Response by climate characterization program	
Issue	SCP section		Activity parameter	SCP activity
1.1, 1.9.1	8.3.5.13, 8.3.5.18.1	Quaternary regional paleohydrology	Paleoflood magnitudes	8.3.1.5.2.1.1
			Paleoflood frequencies	8.3.1.5.2.1.1
			Paleoflood hydraulic characteristics	8.3.1.5.2.1.1
			Paleoflood debris movement quantities	8.3.1.5.2.1.1
			Paleoflood debris movement characteristics	8.3.1.5.2.1.1
			Travel times of Cl ³⁶ and C ¹⁴	8.3.1.5.2.1.2
			Unsaturated zone water isotopic characteristics	8.3.1.5.2.1.2
			Unsaturated zone water chemical characteristics	8.3.1.5.2.1.2
			Past evapotranspiration rate	8.3.1.5.2.1.3
			Past potentiometric head	8.3.1.5.2.1.3
			Location, type, and extent of hydrogeologic units	8.3.1.5.2.1.3
			Transmissivity	8.3.1.5.2.1.3
			Discharge of paleoseeps and paleosprings	8.3.1.5.2.1.3
			Locations of paleoseeps and paleosprings	8.3.1.5.2.1.3
			Analog infiltration rate	8.3.1.5.2.1.4
			Analog recharge rate	8.3.1.5.2.1.4
Analog site effective moisture	8.3.1.5.2.1.4			

8.3.1.5-11

CONSULTATION DRAFT

Table 8.3.1.5-2. Activity parameters provided by the climate program that support performance and design issues (page 6 of 6)

Calls by performance and design issues		Parameter category	Response by climate characterization program	
Issue	SCP section		Activity parameter	SCP activity
1.1, 1.9.1 (continued)	8.3.5.13, 8.3.5.18.1 (continued)	Quaternary regional paleohydrology (continued)	Mineralogy of calcite-silica deposits	8.3.1.5.2.1.5
			Petrology of calcite-silica deposits	8.3.1.5.2.1.5
			Morphology of calcite-silica deposits	8.3.1.5.2.1.5
			Paleontology of calcite-silica deposits	8.3.1.5.2.1.5
			Chemistry of calcite-silica deposits	8.3.1.5.2.1.5
			Ages of calcite-silica deposits	8.3.1.5.2.1.5
			Isotopic concentrations of calcite-silica deposits	8.3.1.5.2.1.5
1.1, 1.9.1	8.3.5.13, 8.3.5.18.1	Paleoclimate/ paleohydrology synthesis	Relationship between climate (e.g. precipitation, temperature, evapotranspiration) and infiltration and recharge	8.3.1.5.2.1.1, 8.3.1.5.2.1.2, 8.3.1.5.2.1.3, 8.3.1.5.2.1.4, 8.3.1.5.2.1.5

8.3.1.5-12

CONSULTATION DEPT

CONSULTATION DRAFT

Table 8.3.1.5-2 provides a direct link between the climate-related performance parameters (Table 8.3.1.5-1) and the activities in the climate characterization program by using "parameter categories." Each parameter category represents a group of activities (and the parameters to be addressed by those activities) that will be used to evaluate the climate-related performance parameters. There are seven parameter categories: present regional climate, Quaternary regional paleoclimate, Quaternary regional paleoenvironment, paleoclimate-paleoenvironmental synthesis, future climate, Quaternary regional paleohydrology, and paleoclimate-paleohydrology synthesis. From Table 8.3.1.5-1, there are essentially four types of performance parameters relating to changes in ground-water flux, changes in the elevation of the water table, changes in the gradient of the water table, and the potential for surface discharge points for ground water in the controlled area. All the parameter categories represent activities that provide information, directly or indirectly, to each of these performance parameters. The most direct link is between the future climate and the paleohydrology-paleoclimate synthesis parameter categories; however, the other categories are linked indirectly to the performance parameters through these categories.

The parameter categories listed in the table, which group the activity parameters, correspond to many of the square boxes on Figure 8.3.1.5-2. Two boxes, "present geohydrologic conditions" and "geohydrologic model," are not represented in the table because these activities do not take place within the climate program. The activity parameters represent either field or measured data or are directly calculated from field or measured data. These activity parameters are generally the output from their associated SCP activity listed in the next column. For data-gathering activities (far right on logic diagram), the associated parameter category is generally just a study-level grouping. For synthesis activities, which analyze data from multiple studies and activities, the parameter categories correspond exactly to the synthesis activities, and the associated activity parameters are the output from the synthesis activity. Modeling activities also have a direct correlation to parameter categories.

In all instances the calls by performance and design issues listed in the first column are derived from Issues 1.1 and 1.9b, and will also be used to satisfy Issues 1.8, 1.9a, 1.10, 1.11, and 1.12.

The following discussion follows the logic diagram and table and ties the climate program to the design and performance issues:

The first data-gathering activity (8.3.1.5.1.1.1) is designed to contribute to the characterization of the present regional synoptic climate along with temporal and spatial variations. This characterization is used to calibrate models of future climate as shown in the figure. The table shows the activity parameters (or data) gathered in this activity along with the parameter category associated with this study (modern regional climate).

The next two data gathering studies, 8.3.1.5.1.2 and 8.3.1.5.1.3, are designed to contribute to a chronology of paleoclimate. These studies draw upon evidence from lake, playa, and marsh sediments and terrestrial ecology (pollen and pack rat middens) to develop a qualitative interpretation of the Quaternary regional paleoclimate. The activity parameters associated with

CONSULTATION DRAFT

these activities are shown in the table and fall under the category "Quaternary regional paleoclimate." These studies form the basis for further activities within the climate program.

Complementing the paleoclimate history will be four data-gathering activities (8.3.1.5.1.4.1 to 8.3.1.5.1.4.4) leading in the same manner to a chronology of paleoenvironment. These activities draw upon lines of evidence from soils, surficial deposits, eolian deposits, and geomorphology. The paleoclimate and paleoenvironmental activities are to be integrated ultimately into a paleoclimate-paleoenvironmental synthesis (Activity 8.3.1.5.1.5.1). It is expected that the principal line of evidence for the synthesis will be the paleoclimate history and that the paleoenvironment history will serve to complement the paleoclimate chronology. This synthesis is necessary for the assessment of long-term variability of paleoclimate and to provide a basis for the estimation of future climatic episodes. In addition, the results of this synthesis activity will be used to determine the potential effects of future climatic conditions on hydrologic conditions. The specific output from this synthesis activity includes an assessment of paleoclimatological conditions, which will be used in the future climate modeling activities and in the paleohydrology activities.

Activities pertaining to the modeling of future climate are shown on Figure 8.3.1.5-3. Activity 8.3.1.5.1.6.1 contains the plans for global climate modeling and does not require input from any previously discussed site activities. The feasibility activity for regional numerical modeling requires information on present regional climate. The purpose of this activity is to determine if a regional numerical model is likely to provide timely and scientifically valid results. An additional empirical modeling activity (8.3.1.5.1.6.4) uses the integrated paleoclimate-paleoenvironmental chronology from Activity 8.3.1.5.1.5.1 to project past climatic episodes into the future. In the empirical modeling approach, the climatological values for past climatic regimes will provide estimates for ranges that may occur in the future. Therefore, the activity parameters listed under the category "future climate modeling" will be derived from either a linked global-regional modeling approach (8.3.1.5.1.6.3), a separate empirical modeling approach (8.3.1.5.1.6.4), or both. This model output will be used to determine the effects of future climate on geohydrology.

Five activities (8.3.1.5.2.1.1 to 8.3.1.5.2.1.5) will generate the data to be used to determine the Quaternary regional ground-water flow system. These activities include estimating severe paleorunoff and paleofloods, determining relationships between paleoinfiltration and paleorecharge, identifying areas of paleorecharge and paleodischarge in the Yucca Mountain region, and assessing the conditions and rates of recharge in that region. The specific activity-level parameters, which consist of measured or collected data, are shown in the table and are used to develop a picture of the paleohydrology at Yucca Mountain.

The data generated to determine the Quaternary regional paleohydrology will then be used along with the paleoclimate-paleoenvironmental data to determine the relationships between paleoclimate and paleohydrology. This synthesis work is not an independent study or activity but rather occurs within each of the paleohydrology activities. The parameter category,

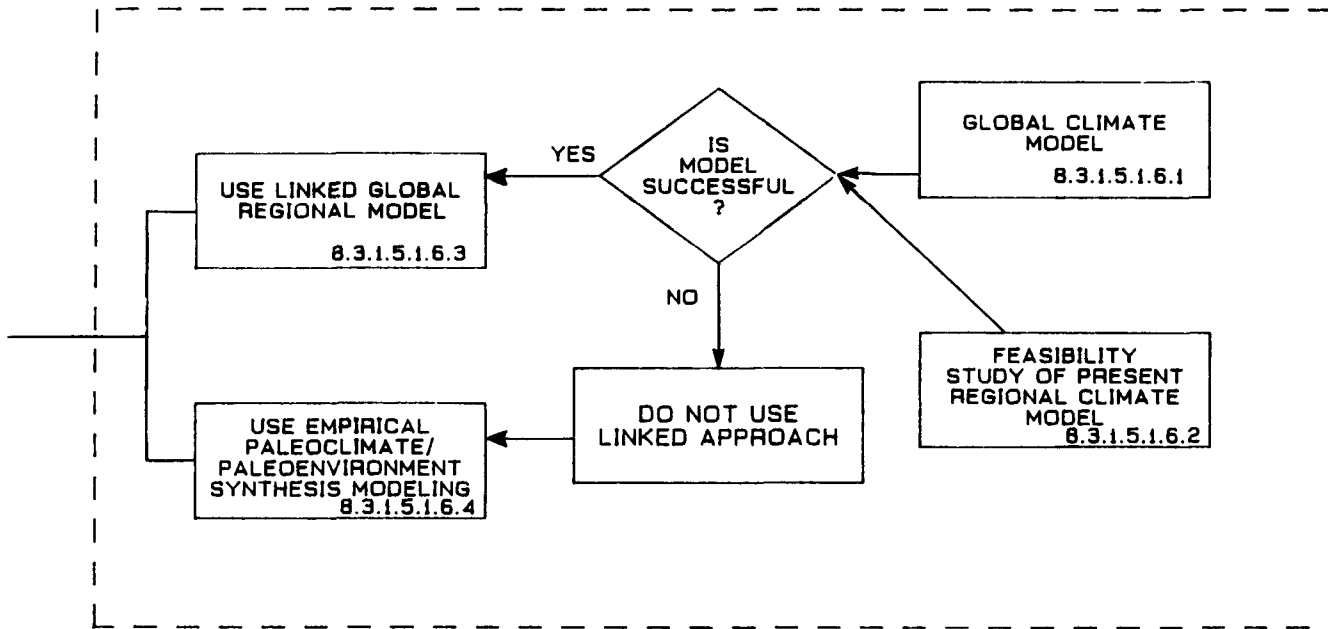

Figure 8.3.1.5-3. Detail of the climate model step (Study 8.3.1.5.1.6) in logic diagram.

CONSULTATION DRAFT

"paleoclimate-paleohydrology," contains one activity parameter, "relationships between paleoclimate and paleoinfiltration and paleorecharge," that is an additional output from each paleohydrology activity.

Activities within the geohydrology program (8.3.1.2) will proceed in parallel with the above mentioned climate program activities. Specifically, studies addressing the unsaturated- and saturated-zone hydrologic system (8.3.1.2.2.10 and 8.3.1.2.3.2) will be used to develop models of the flow systems in both the unsaturated and saturated zones. These models will be used to assist in the evaluation of baseline hydrologic conditions.

At this point, information will be available (1) on future climatic conditions, (2) on the relationships between paleohydrology and paleoclimate, and (3) from the geohydrology program (models of flow systems of the unsaturated and saturated zones and the surface water system) as shown in Figure 8.3.1.5-2. These three sources of information will be used by climate program Study 8.3.1.5.2.2 to characterize future regional hydrologic conditions based on the estimated climatic changes. The result of this study will be an estimate of the impact of future climate changes on the overall hydrologic system. The first activity (analysis of future surface hydrology) will result in a determination of future precipitation-runoff relationships to be used by the erosion program (8.3.1.6). The next activity (analysis of future unsaturated-zone hydrology) will provide quantitative estimates of future infiltration, percolation, and saturation of the unsaturated zone due to climatic changes, which are essentially some of the performance parameters listed in Table 8.3.1.5-1 used to satisfy the performance objectives of Issues 1.1 and 1.9b. The final activity will provide estimates of future water-table altitude, ground-water flow rates, and ground-water velocity, corresponding to other performance parameters listed in Table 8.3.1.5-1. The performance parameters listed in Table 8.3.1.5-1 will address the performance objectives of Issues 1.1 and 1.9b and therefore Issues 1.8, 1.9a, 1.10, 1.11, and 1.12.

The information presented in Table 8.3.1.5-2 is a step toward the development of "characterization parameters" for the climate program. Characterization parameters will be a specific limited set of parameters for which quantitative testing bases will be established. These testing bases will express, through parameter goals or degree of accuracy, how well a particular parameter important to the climate program needs to be understood. Characterization parameters will be developed from the individual activity parameters in the following parameter categories: paleoclimate-paleo-environment synthesis, future climate, and paleoclimate-paleohydrology synthesis. An example of one such characterization parameter is future precipitation. Initial sensitivity analyses performed on the hydrologic models will provide an idea as to how well future precipitation is needed to be known and what ranges of values are significant. This process will help to guide the future climate modelers as to how well they need to determine future precipitation and aid in prioritizing the activities within the climate testing program.

Interrelationships of climate investigations

Investigation 8.3.1.5.1 is designed to address the data, parameters, and processes that can be used to derive a model of future climatic change. This

CONSULTATION DRAFT

model is needed to predict potential future climatic changes that may (through the hydrologic regime) alter the long-term waste isolation capability of the Yucca Mountain site.

Data will be collected to characterize the present regional climate (Study 8.3.1.5.1.1) including the spatial and temporal variation. A study of the climatic inferences from paleolake, playa, and marsh sediments (Study 8.3.1.5.1.2) will draw upon the paleontology, stratigraphy, sedimentology, geochemistry, and chronology of these deposits. A study of the climatic implications of terrestrial paleoecology (Study 8.3.1.5.1.3) will draw upon evidence from pack rat midden macrofossils, palynology, and vegetation-climate relations. A paleoenvironmental study of the Yucca Mountain site (Study 8.3.1.5.1.4) will draw upon investigations into rates and conditions of soil development, distribution and geomorphology of surficial deposits, and the eolian history of the region. The paleoclimate history (from Studies 8.3.1.5.1.1 through 8.3.1.5.1.3) and the paleoenvironment history (8.3.1.5.1.4) will cross-check and complement each other and will be combined to create a final paleoclimate-paleoenvironment synthesis (Study 8.3.1.5.1.5), an integrated chronology, and a description of paleoclimate episodes at Yucca Mountain and environs.

The chronology produced in Study 8.3.1.5.1.5 will serve as the data base for the culmination of Investigation 8.3.1.5.1, modeling of future climates (Study 8.3.1.5.1.6). This study will employ a parallel approach of empirical modeling and numerical modeling to describe the timing and meteorology of future climate scenarios. This output will be used in Investigation 8.3.1.5.2 to estimate responses of the hydrologic regime to future climate.

Investigation 8.3.1.5.2 is designed to address the potential effects of future climatic conditions on hydrologic conditions. The characterization of Quaternary regional hydrology (Study 8.3.1.5.2.1) has the overall objective of defining relations between paleohydrology and paleoclimate, in order to understand how the hydrologic regime will respond to future climatic conditions. The study is planned to evaluate regional paleoflooding (Activity 8.3.1.5.2.1.1) and to assess both infiltration and percolation in the unsaturated zone and also ground-water potentiometric levels during the Quaternary (Activity 8.3.1.5.2.1.2). Isotopic composition and chemistry of water in the unsaturated zone will be analyzed to assess the Quaternary infiltration and recharge history of Yucca Mountain. An evaluation of paleodischarge areas and an evaluation of past water levels in carbonate caverns (Activity 8.3.1.5.2.1.3) will be completed to determine past discharge areas and regional ground-water levels. Potential modern analogs to pluvial climates at Yucca Mountain will be studied (Activity 8.3.1.5.2.1.4) to estimate conditions and rates of ground-water recharge at Yucca Mountain during the Quaternary. The hydrologic origin and significance of calcite and silica deposits in faults and fractures in the vicinity of Yucca Mountain (Activity 8.3.1.5.2.1.5) will be factored into this evaluation.

A study is planned to characterize the future regional hydrology taking into account future climatic changes (Study 8.3.1.5.2.2). A precipitation-runoff model is planned to simulate paleoconditions of precipitation and runoff (Activity 8.3.1.5.2.2.1). The model will then be used to estimate future precipitation-runoff conditions from scenarios for future climatic

CONSULTATION DRAFT

change. In addition, the unsaturated zone hydrologic model will be used to predict the potential changes in infiltration, percolation, and the degree of saturation due to future climatic change (Activity 8.3.1.5.2.2.2).

Finally, a synthesis of future hydrologic characteristics due to climatic changes will be completed (Activity 8.3.1.5.2.2.3). The objective of this study will be to integrate data on paleoclimatic and paleohydrologic conditions to complete a reconstruction of paleoclimatic conditions. The paleoclimatic reconstruction will be used, together with the meteorology of future climate scenarios and models of the present ground-water regime from Section 8.3.1.2 (geohydrology program), to predict the impacts of future climatic change on the unsaturated and saturated zone hydrologic system at Yucca Mountain. This study will involve incorporating paleohydrologic data into models to estimate potential changes in the altitude and gradient of the water table caused by future climatic change.

The schedule information provided for investigations in this section includes the sequencing, interrelationships, and relative durations of the studies in the investigation. Specific durations and start/finish dates for the studies are being developed as part of ongoing planning efforts and will be provided in the SCP at the time of issuance and revised as appropriate in subsequent semiannual progress reports.

8.3.1.5.1 Investigation: Studies to provide the information required on nature and rates of change in climatic conditions to predict future climates

Technical basis for obtaining the information

Link to the technical data chapters and applicable support documents

The following sections of the SCP data chapters provide a technical summary of existing data relevant to this information need:

<u>SCP section</u>	<u>Subject</u>
5.1	Recent climate and meteorology
5.2.1.1	Quaternary global paleoclimate
5.2.1.2	Quaternary regional paleoclimate
5.2.2.1	Components of the climate system
5.2.2.2	Climatic variations
5.2.2.3	Climate prediction methods
5.2.3	Site paleoclimatic investigations
5.3.1	Significant results

Parameters

The following parameters will be collected, measured, or calculated as a result of the site studies planned as part of this investigation:

CONSULTATION DRAFT

1. Recent meteorological data.
2. Great Basin historical climatic data--spatial and temporal variability of precipitation, wind, temperature, cloud cover.
3. Selected Great Basin hydrologic data--stream discharge, lake level.
4. Age, fossil content, sedimentary characteristics, mineral content, chemical content, and magnetic properties of lake, playa, and marsh sediments.
5. Age and paleontologic characteristics of pack rat midden macrofossil assemblages.
6. Vegetation-climate calibrations--response surfaces, transfer functions.
7. Prehistoric variation in lake levels over the Quaternary.
8. Synoptic "snapshots" of prehistoric climate extremes.
9. Analysis of Quaternary soil and surficial deposit properties, and Quaternary geomorphic characteristics of surfaces and drainages.
10. Forecasts (a general estimation, not a specific parameter or variable) of climatic variables for the next 100,000 yr in southern Nevada.

Other site studies that supply information to support the determination of the previous parameters are as follows:

<u>Study</u>	<u>Subject</u>
8.3.1.12.1.1	Characterization of the regional meteorology
8.3.1.2.2.1	Characterization of unsaturated zone infiltration
8.3.1.5.2.1	Characterization of Quaternary regional hydrology
8.3.1.6.1.1	Distribution and characteristics of past erosion

Purpose and objectives of the investigation

Investigation 8.3.1.5.1 provides information to help satisfy performance and design Issues 1.1, 1.8, 1.9a and b, 1.10, 1.11, and 1.12. Recent meteorological data and Great Basin historical climate data will be used to calibrate (using present conditions) and validate (using past conditions) models of future climate. A paleoclimate-paleoenvironment synthesis will be derived from lake, playa, and marsh sediments, pack rat middens, vegetation calibrations, and soil and surficial deposits. This synthesis will provide time-sequential reconstructions for the modeling activities as well as for Investigation 8.3.1.5.2. These models will attempt to forecast climatic variables for the next 100,000 yr to determine climatic conditions.

CONSULTATION DRAFT

Technical rationale for the investigation

The arid climate of the southern Great Basin is one of several factors making Yucca Mountain potentially attractive for the long-term disposal and isolation of radioactive waste. The persistence of arid conditions (and an accompanying thick unsaturated zone) in the region through the postclosure period would be advantageous to waste isolation. However, paleoclimatic studies in the surrounding region indicate that the modern degree of aridity is atypical of the past few hundreds of thousands of years. Shallow groundwater recharge occurred in southern Nevada between 20,000 and 10,000 yr ago (Claassen, 1985), when major climatic changes created vast lakes in many of the valleys of Nevada, Utah, and eastern California (Section 5.2). Although such high magnitude events may be cyclic on a time scale of 100,000 yr, most of the intervening periods appear to have been wetter than today (Smith, G.I., 1983).

When viewed on a scale of hundreds to thousands of years, climate is constantly changing, and future climatic fluctuations may significantly affect the hydrologic regime and erosion rates at Yucca Mountain. Thus, climate change must be considered when evaluating the suitability of the repository site.

If data are discovered within the Quaternary geologic period that document the above objectives, they will be studied. The exact studied time interval will be flexible depending upon the completeness of the recovered stratigraphic data. However, the late Quaternary will be emphasized.

Climatic scenarios of concern. Our present understanding of past climates suggests that there are primarily two recurring large-scale circulation patterns which may result in higher levels of effective moisture in southern Nevada. The future occurrence of either pattern could have a negative impact on the proposed repository. The first pattern is associated with the growth of continental ice sheets during glacial periods. Under modern conditions, the westerlies and the associated jet stream are strongest and in their most southerly position during winter, when cold arctic air is in close proximity to warm tropical air. During glacial periods, arctic air masses reached farther south than today in all seasons, but tropical air did not contract towards the equator to any significant degree (because orbitally induced variations in insolation have little effect in low latitudes). Thus, polar and tropical air masses would interact with each other year round in a region farther south than today, thereby potentially increasing frontal activity (storminess) and precipitation in the NTS region. An increase in frontal activity through the year would increase precipitation and reduce evaporation, factors that have the potential to increase recharge.

The second pattern involves an orbitally induced variation in insolation that results in higher than modern summer temperatures over land in the middle and high latitudes of the northern hemisphere. Under such conditions about 9,000 yr ago, the increased temperature contrast between land and sea brought moist tropical air masses (monsoons) into North Africa and the Indian subcontinent. The resulting increased rainfall and reduced evaporation turned now desert areas into savannas and woodlands (Kutzbach and Otto-Bleisner, 1982). Similar changes have been postulated to have occurred in

CONSULTATION DRAFT

the NTS region (Spaulding and Graumlich, 1986) and may occur again in modified form if future increases in atmospheric CO₂ concentrations cause a "greenhouse effect" on global climate.

In addition to the two patterns described above, both associated with extremes in glacial and solar insolation boundary conditions, it appears that other, more moderate, configurations of boundary conditions may result in high levels of effective moisture in the region of southern Nevada. For example, within 150 km of Yucca Mountain moderate to high lake levels were maintained for much of the period between the last interglacial (about 125,000 yr before present) and the last glacial maximum (about 20,000 yr before present) (G. I. Smith, 1983).

Paleoclimatic studies at Yucca Mountain will attempt to determine the past frequency and timing of occurrences of the scenarios listed above and to identify other patterns of past climatic circulation that led to high levels of effective moisture. Future climatic studies will attempt to estimate the probability of occurrences of these and other scenarios over the next 10,000 to 100,000 yr.

Paleoclimatic studies. The primary objectives of the paleoclimatic studies are to

1. Determine the magnitude, duration, and timing of past major periods effectively wetter than modern conditions in and near southern Nevada.
2. Provide data to establish the relationships between paleoclimate change and corresponding paleohydrologic responses.
3. Establish, where possible, the relationships between past climatic changes near Yucca Mountain and predictable elements of larger scale (global or northern hemispheric) climatic changes, such as those induced by changes in the earth's orbit.
4. Provide the basis for the validation of numerical climate models.

Constituent studies. The studies under the paleoclimatic investigation are

1. Study 8.3.1.5.1.1--Characterization of modern regional climate. The modern climate is the baseline for establishing the relationships between climatic variables (such as precipitation or temperature) and the various proxy data (such as plant distributions or lake size or chemistry). Thus, understanding modern climate is essential to reconstructing the past and predicting the future.
2. Study 8.3.1.5.1.2--Paleoclimate study: lake, playa, marsh deposits. Paleontological, stratigraphic-sedimentologic, and geochemical indicators preserved in lacustrine sediments provide the principal record of paleohydroenvironments, which for most shallow water systems are also sensitive paleoclimate records and the only available long records of climate change. These records will provide relative

CONSULTATION DRAFT

estimates of climate properties and in some instances may provide quantitative estimates of climate.

3. Study 8.3.1.5.1.3--Climatic implications of terrestrial paleoecology. Plant macrofossil assemblages from pack rat middens and fossil pollen spectra from stratigraphic deposits will provide the basis for reconstructing vegetation change near Yucca Mountain and in the surrounding region. Numerical methods (response surfaces, transfer functions) will translate these vegetation records into quantitative estimates of past changes in precipitation, temperature, and other climatic variables.
4. Study 8.3.1.5.1.4--Paleoenvironmental history. Investigations of soils and surficial deposits at Yucca Mountain are necessary to define the responses of local depositional and erosional regimes to climatic change.
5. Study 8.3.1.5.1.5--Paleoclimatic-paleoenvironmental synthesis. The various lines of evidence will be synthesized into chronologies of paleoclimatic changes in formats suitable for input into the paleohydrologic studies and the future climates studies.

Spatial scale. Investigators working within the paleoclimate program will attempt to discover any available evidence of past periods of greater than modern effective moisture in as close proximity to Yucca Mountain as possible. Data bearing on this problem that are available near the proposed repository include (1) plant assemblages from pack rat middens; (2) micro-paleontological, geochemical, and sedimentological data from playa and paleomarch sediments; (3) terrestrial pollen data; and (4) vertebrate paleontological data from outcrops, pack rat middens, and paleomarch sediments. (Refer to Tables 5-13 and 5-14 and Figure 5-24 for an analysis of currently available data.) In addition to these data, the age and nature of surficial deposits and soil development will be assessed, as appropriate, to develop an understanding of the paleoclimatic record at Yucca Mountain.

The characteristics of local playa and marsh records are planned to be evaluated in terms of climatic sensitivity, sediment accumulation rates, and preservation of paleontologic and mineralogic climatic indicators.

These records

1. Represent available aquatic record of Quaternary climatic and hydrologic events near Yucca Mountain.
2. Have direct bearing on hydrologic models and the tie between regional climatic change and local hydrologic changes.
3. Can be related to regional framework of climatic and hydrologic changes developed through regional paleoclimatic studies (discussed below). In this light, local aquatic records will provide evidence on climatic episodes that have resulted in significant hydrologic responses in this area but are of much less importance regionally.

CONSULTATION DRAFT

Climate is operative on a regional scale, and no single station or paleoclimatic site can provide an adequate record of past variability or be representative of the climate over the entire recharge area. The same characteristic applies to paleoclimatic records, which, on a regional scale, are necessary to provide a check on the continuity of the local records thereby reducing the uncertainty involved in identifying major past periods of higher effective moisture. Regional records, especially from extant lakes and wet playas, should provide thicker stratigraphic sections and greater temporal resolution for dating past periods of major recharge. The potential for missing portions of the record through deflation, etc. will be minimized by studying such sites. Regional scale data are also necessary for describing variations in past storm track positions, for the validation of climatic models, and for testing hypotheses on temporal and spatial patterns of climatic change. These aspects would require a spatial network of sites for key time periods in the past. The sources of paleoclimatic proxy data available on a regional scale are the same as on the local scale, with the notable addition of permanent lakes as sources of micropaleontological, geochemical, and sedimentological data.

Temporal scale. Over the last 50,000 yr, the climate of the Northern Hemisphere has changed from "interstadial glacial" (about 65,000 to 35,000 yr before present), to "full-glacial" conditions (about 20,000 to 18,000 yr before present), to conditions warmer than today (about 9,000 to 6,000 yr before present), to modern conditions. This period thus offers examples of extreme configurations of global climatic boundary conditions, and the effects of these changes in southern Nevada are planned to be studied in detail. Available techniques for dating paleoclimatic changes are also most precise over this period and "synoptic snapshots" of paleoclimatic conditions at appropriate times in southern Nevada can be constructed for numerical model validation.

The global climates of the next 10,000 to 100,000 yr may include a transition from the current interglacial, to moderate glacial, to full-glacial conditions. To understand the ramifications of this change, the last 200,000 yr are planned to be studied in moderate detail to provide examples of the climatic effects of such global changes on the Yucca Mountain region.

Over the last 500,000 to 1,000,000 yr, climatic conditions have varied enough to allow boreal small mammals such as the bog-lemming to live in wet seeps on Yucca Mountain. Some knowledge of these seemingly very different conditions is required to predict the possible magnitudes of future wet episodes at Yucca Mountain.

Future climate investigations. Forecasts of future climatic conditions at Yucca Mountain will be made primarily through numerical models of the climate system. A general circulation model (GCM) of global climate will be used to describe the expected responses of global climate to future variations in glacial ice extent, orbital parameters (which affect the distribution of incoming solar radiation on the earth's surface), atmospheric chemistry, and other climatic boundary conditions. A regional-scale meso-scale model will be linked to the GCM to provide the spatial resolution necessary for forecasting the future climatic conditions at Yucca Mountain.

CONSULTATION DRAFT

Before numerical models can be used to forecast future climatic conditions, they must incorporate evidence of past climatic change as reconstructed from paleoclimatic proxy data in the region on time scales commensurate with the periodicity of earth-sun orbital relations. This refinement is necessary because of the effects of complicated feedback systems, lag times, and topographic barriers on climate. It is performed by comparing paleoclimate records with model results and by improving the model so that it simulates known past climates more accurately.

The models will be calibrated and checked using present-day and historical data sets that will be validated in simulations of climates of key historic times such as periods of high lake stands, desiccation, vegetative change, or ground-water recharge.

Following successful model validation exercises, scenarios will be developed that include boundary conditions to account for inputs from natural and human activities to the atmosphere. The possible effects of volcanic dust, aerosol, and carbon dioxide on future climate conditions will be examined.

8.3.1.5.1.1 Study: Characterization of modern regional climate

The objective of this study is to provide a baseline and a background for the interpretation of climatic variation. Characterization of the synoptic climate will result in the determination of modern spatial and temporal variations in precipitation, air temperature, cloud cover, and other meteorological variables. These data will be used in the development of modern vegetation-climate calibration relationships, in the assessment of lake-climate relationships, and in the development and testing of climate circulation models and in specifying relationships between global-scale circulation patterns and the regional and local climate features of relevance to site performance coordinated by the overview activity in Section 8.3.1.12.1.2.1.

In cooperation with Meteorology Program 8.3.1.12 and Geohydrology Program 8.3.1.2, efforts will be made to relate modern storms (and their trajectories) to the isotopic signatures of infiltrating ground water. This analysis will be assisted by modeling of the carbon isotope systematics in ground water. These data may provide insight into past air-mass trajectories and will be available to the climatology program.

8.3.1.5.1.1.1 Activity: Synoptic characterization of regional climate

Objectives

The objectives of this activity are to

1. Provide the basis for developing vegetation-climate relationships, lake-climate relationships, and climate-circulation models (meteorological data).

CONSULTATION DRAFT

2. Provide an understanding of spatial and temporal variation in climate (synoptic climate).
3. Determine the climate conditions (i.e., time, temperature, seasonality, and air masses) under which recharge occurs (isotopic data).

Parameters

The parameters for this activity are

1. Meteorological data, such as monthly and annual values for temperature, precipitation, wind-velocity, from a regional network of sites.
2. Synoptic climate, such as spatial and temporal variation of precipitation, air temperature, cloud cover, and wind velocity.

Description

Meteorological data will be compiled from U.S. Weather Service stations from the southern Great Basin and surrounding region. The synoptic climate of the Great Basin region will be determined through statistical correlations with larger scale climate information. These correlations will include the longest usable climatic record, including possible use of tree ring data if applicable, and will be used to identify patterns of specific weather system development and to determine how the systems affect areas of particular interest within the Great Basin.

A network of weather stations will be set up in the region, in cooperation with meteorology program 8.3.1.12 and geohydrology program 8.3.1.2. Each station will include a precipitation collector for oxygen-18 and deuterium samples, a tipping bucket, and a temperature probe connected to a data logger. Temperature data will be collected every 15 to 20 minutes; water samples will be collected whenever possible within 24 hours of a storm event. The data will be statistically analyzed to determine the relation of oxygen-18 to deuterium to storm track, air temperature, altitude, and season. Results of the analysis will be used in Study 8.3.1.5.1.2 (paleolacustrine studies) to assist in estimating the source and seasonality of recharge that occurred in the Quaternary in the Yucca Mountain region and in Activity 8.3.1.5.2.1.2 (Quaternary unsaturated zone hydrochemical analysis).

Methods and technical procedures

The methods and technical procedures for Activity 8.3.1.5.1.1.1 are given in the following table.

CONSULTATION DRAFT

Method	Technical procedure		Date
	Number	Title	
	(NWM-USGS-)		
Collection, tabulation, and statistical analysis of historical climate data sets	TBD ^a	Historical climate data sets	TBD
Collection and preservation of atmospheric precipitation samples for isotope analysis	HP-16, R1	Collection and preservation of atmospheric precipitation samples of isotope analysis	14 Aug 84
Stable isotope sampling analysis	TBD (in preparation)	Stable isotope analysis of solid samples	TBD
CHEMTRAN modeling of carbon cycle during recharge to ground-water system	TBD (in preparation)	CHEMTRAN software	TBD

^aTBD = to be determined.

8.3.1.5.1.2 Study: Paleoclimate study: lake, playa, marsh deposits

This study will establish the nature, timing, duration, and amplitude of paleoclimate changes based on analyses of paleontologic, geochemical, and stratigraphic-sedimentologic data obtained from lacustrine sediments in or near southern Nevada (Figure 8.3.1.5-4). Planned locations of the marsh, playa, and lake sampling sites may change as data are collected and analyzed. Any such changes will be reported in study plans and SCP progress reports. In addition, information will be collected on paleolake levels and sizes to identify the timing and extent of paleoclimate events. These analyses will provide estimates of past changes in precipitation, temperature, relative moisture balance, and other climatic parameters. These estimates, when integrated regionally for particular climatic episodes, will aid in identifying the particular pattern of atmospheric circulation (air-mass interactions) responsible for the observed variations. Moreover, these estimates will provide the basic data to be used for analyzing past climatic periodicity and for validating climate models.

Because climate variability may contribute significantly to the hydrologic system, especially in terms of recharge and discharge, the results of this study will also be central to the paleohydrologic studies of this area

CONSULTATION DRAFT

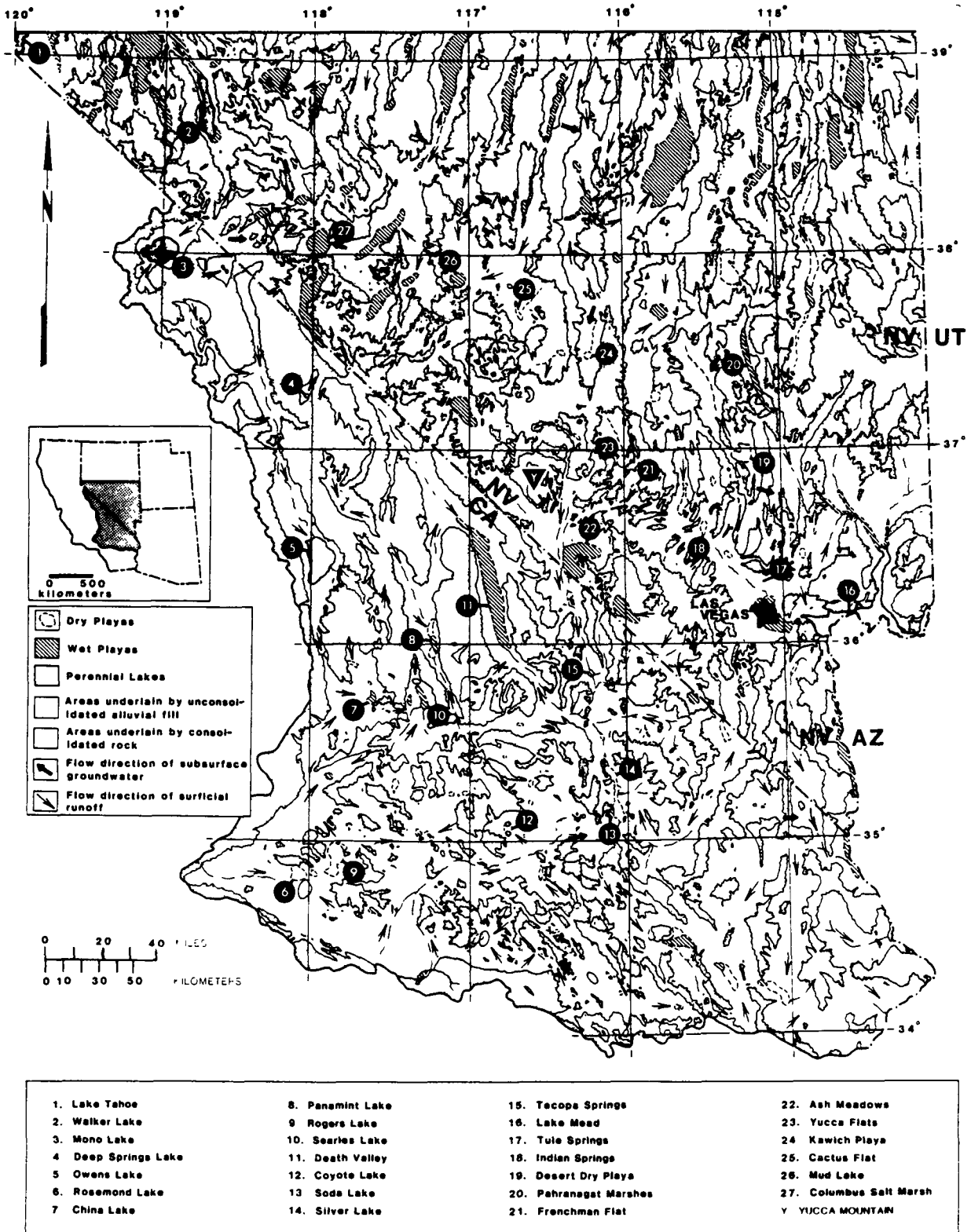

Figure 8.3.1.5-4. Possible sampling sites for paleoclimate studies. Modified from Bedinger et al. (1984).

CONSULTATION DRAFT

(Section 8.3.1.5.2). The degree to which past climatic and past hydrologic changes are linked will provide a basis for comparing or linking the outputs of models that predict future climatic and hydrologic variability.

8.3.1.5.1.2.1 Activity: Paleontologic analyses

Objectives

The objective of this activity will be to assemble and interpret, in paleoclimatic terms, detailed records of ostracodes, diatoms, and pollen, along with other types of fossils as warranted by specific paleoclimatic questions. This record will involve collection, identification, enumeration, and interpretation of paleontologic data that emphasizes the past 50,000 yr in great detail, the past 200,000 yr in moderate detail, and the past 1,000,000 yr in some detail. Calcareous fossils will also be collected for geochemical and age analyses of their carbonate.

Parameters

The parameters for this activity include paleoenvironmental interpretations of ostracodes, diatoms, aquatic palynomorphs, and other paleobiotic remains.

Description

Ostracodes. Ostracodes are minute crustacea with bivalved calcite carapaces that can be identified to the generic or specific levels. They are largely benthic animals, living at or just below the sediment-water interface. Ostracode life-cycles range from about three weeks to well over a year, and their ecology is therefore centered upon annual or seasonal phenomena. Ostracodes live in virtually all oxygenated water bodies that persist for more than about a month. They attain their highest population densities in quiet or gently flowing water and are most commonly preserved in circumneutral to alkaline water.

Nonmarine ostracodes are divided into two major ecologic groups: those that live in surface waters (epigean) and those that live in ground water (hypogean). Epigean taxa may be further divided ecologically into those living in ground-water discharge environments and those that live in lacustrine environments. Both ground-water discharge and lacustrine taxa may be further subdivided into groups of taxa that only live in very particular environments such as continuously cold water (cryobionts) or continuously warm water (thermobionts), or water that is warm for at least a given period during the year (thermophilic). Ostracodes are very sensitive to water chemistry, with the distribution of some taxa determined by the major dissolved ion content of the water. Other parameters, such as turbidity, oxygen levels, and biotic factors appear to influence ostracode productivity rather than their presence or absence.

Most ostracode species have well-defined biogeographic ranges that appear to be limited by seasonal variations in water temperature and chemistry. Ostracodes are capable of entering new environments through the

CONSULTATION DRAFT

transport of adult ostracodes or eggs by birds, insects, or wind. Similarly, as environments change, some species will no longer be able to survive and will become locally extinct. Thus ostracodes may rapidly expand or contract their geographic ranges in response to changing hydroenvironmental and climatic conditions. Ostracodes will be collected in conjunction with Activity 8.3.1.5.2.1.3 (evaluation of past discharge areas).

Diatoms. Diatoms are single-celled algae that produce an opaline silica frustule, which provides precise taxonomic information. Various species of diatoms cover a range of aquatic habitats from the sediment-water interface to the open-water epilimnion. Diatoms are short-lived organisms and therefore can respond by increasing species abundance to environmental phenomena operating on weekly time scales.

Particular diatom species are known from all aquatic environments within the photic zone. Diatom species are especially sensitive to water quality, including parameters such as solute composition, salinity, and pH. They are also extremely sensitive to the availability of nutrients such as nitrogen, phosphorous, silica, and dissolved organic compounds.

Diatoms have an excellent fossil record, and, unlike ostracodes, diatoms are commonly preserved in acidic environments or any environment low in HCO_3^- activity. Where both groups of organisms are preserved, the diatoms may provide useful information on short-term environmental phenomena that may have no obvious impact on the ostracode population. Conversely, ostracodes appear to be better suited to recognizing what may be termed the general environmental aspects of an aquatic environment such as temperature or water composition.

Aquatic palynomorphs. The pollen record of emergent or submergent macrophytes and the remains of certain algae provide important information about the chemical, and to a lesser extent thermal, properties of the water in which they lived. The response of aquatic plants to their general chemical environment is quite similar to the response of diatoms and ostracodes discussed above. In addition, aquatic macrophytes are sensitive to the stability of a water mass. For example, emergent plants such as cattails require that local water level remain within a specified range or they will drown from rising water levels or desiccate from falling levels. The stability of a water body on a seasonal to annual scale is an important hydrologic and climatic property.

Other biotic remains. Other fossils, ranging from terrestrial vertebrates to aquatic chrysophyte cysts and branchiopods, may prove vital to understanding the nature of a particular climate record. The way in which climate interpretations would be made from other kinds of fossils generally follows the format given above for ostracodes, diatoms, and pollen. Other types of fossils can be used to evaluate and refine the climatic interpretations derived from the principal organisms and may offer information not available from these organisms. For example, the occurrence of branchiopod fossils together with ostracodes implies a wet-playa hydrology whereas the presence of branchiopods without ostracodes implies a dry-playa hydrology. The recognition of a wet and dry playa record from cores in the modern day dry playas near Yucca Mountain would have climatic significance.

CONSULTATION DRAFT

Paleoclimatic interpretations of aquatic records. The ecologies of ostracodes, diatoms, and other aquatic organisms are necessarily related to the properties of the water in which they live. To extract climatic information from the fossil record of aquatic organisms, a relationship between aquatic parameters and climate parameters must be established.

Shallow wet-playa lakes, marsh ponds, and spring pools from shallow aquifers are surface-water features that are common today and were common in the past in southern Nevada. The water columns in each of these environments will typically be thermally coupled to the daily or weekly changes in air temperature over the water body (Forester, 1987). Furthermore, the water temperature of spring vents from shallow aquifers provide good estimates of mean annual air temperature. The seasonal variability in water temperature of standing bodies or the constant value of spring vents provides a thermal habitat that determines occurrence and abundance of all aquatic organisms, but especially ostracodes. New taxa appear as the thermal habitat changes with changing climate, while others become locally extinct. Thus knowledge about the thermal ecology and biogeography of aquatic taxa provides direct information about water temperature that may then be interpreted in terms of air temperature. These interpretations may be qualitative, based on empirical observations; semiquantitative, based on multivariate analyses techniques; or quantitative, based on statistical analyses and organism physiology.

Climate may play an important role in determining water chemistry when water with a given input composition is evaporatively coupled to the atmosphere over the basin. Wet periods result in dilution or flushing of dissolved salts from the basin. Dry periods result in concentration and solute evolution due to selective mineral precipitation and other processes. The chemistry of the surface water body is thus coupled to the atmospheric moisture balance over the water body. The chemical character of the water establishes a chemical habitat that determines organism occurrence and abundance. As the chemical habitat changes with changing climate, new taxa appear or become locally extinct and thus provide a record of the paleochemistry. Thus knowledge about the chemical ecology of aquatic taxa, especially diatoms and ostracodes, provides direct information about paleohydrochemistry that may be interpreted in terms of moisture balance. As with paleotemperature, these interpretations may be qualitative, semiquantitative, or quantitative.

The response of water chemistry to climate is operative on all time scales and for basins of all sizes whereas the response of water temperature to climate may be most sensitive in shallow water bodies that remain thermally mixed in all seasons. Aquatic records, whether they provide only hydrologic or both hydrologic and climatic information, are important to any study that seeks to understand past climate, because they are integrating climate processes that are operating on seasonal or annual scales rather than the much coarser scales common to other records.

Methods and technical procedures

The methods and technical procedures for Activity 8.3.1.5.1.2.1 are given in the following table.

CONSULTATION DRAFT

Method	Technical procedure		
	Number	Title	Date
	(NWM-USGS-)		
Palynological and paleo-ecological analyses	HP-76, RO	Diatom enumeration studies	08 Apr 85
	HP-78, RO	Ostracode sample preparation and data acquisition procedures	08 Apr 85
	TBD	Analyses of other fossils	TBD
	TBD	Pollen analysis	TBD

^aTBD = to be determined.

8.3.1.5.1.2.2 Activity: Analysis of the stratigraphy-sedimentology of marsh, lacustrine, and playa deposits

Objectives

The objectives of this activity are to

1. Identify and characterize the general physical and chemical properties of sedimentary units from outcrops, shore deposits, and cores. This information will provide a physical and relative temporal framework within which various paleoenvironmental studies will be made.
2. Determine the specific environment of deposition for the sedimentary units using the principles of clastic and chemical sedimentology.

Parameters

The parameters for this activity are

1. Lithostratigraphy of marsh, lacustrine, and playa deposits.
2. Clastic and chemical sedimentology of marsh, lacustrine, and playa deposits.

CONSULTATION DRAFT

Description

Reconnaissance coring, trenching, and seismic techniques will provide information about sample sites, access to sediments that cannot be sampled in outcrop, and general information about subsurface stratigraphy for all forms of analyses. This will minimize needed samples and maximize the climatic information obtained from the samples.

Lithostratigraphy involves the lithologic characterization of sedimentary units in order to define sedimentary units and to place these units in space and time. Investigations will describe sediment thickness, color, grain size, texture, bedding, magnetic susceptibility, bulk elements, mineralogy, and other properties deemed necessary for accomplishing this task.

Clastic and chemical sedimentology involves identifying and describing the chemical and physical nature of the sedimentary units identified by lithostratigraphy in order to define the nature of the depositional environment. Properties such as grain size, composition, bedforms, nature of contacts between sediment units or other properties that will aid in interpreting deposition environment will be investigated. Sedimentologic data provide general paleoclimatic information together with general environmental boundary conditions for other studies.

Methods and technical procedures

The methods and technical procedures for Activity 8.3.1.5.1.2.2 are given in the following table.

Method	Technical procedure		
	Number	Title	Date
	(NWM-USGS-)		
Coring, trenching, and sampling of lake, playa, and marsh sediments.	GCP-02, R1	Labeling, identification, and control of geochronology samples and separates	20 Jan 87
	GP-07, R0	Geologic trenching studies	15 June 81
	HP-37, R0	Preliminary procedure for drilling and coring of wet and dry lake sediments	14 Aug 84

CONSULTATION DRAFT

8.3.1.5.1.2.3 Activity: Geochemical analyses of lake, marsh, and playa deposits

Objectives

The objective of this activity is to provide a detailed chemical and mineralogic characterization of all sediments to provide information about the chemistry of the water from which the minerals precipitated and to determine sediment provenance.

Parameters

The parameters for this activity are

1. Element analyses of bulk sediments.
2. Carbonate mineralogy.
3. Noncarbonate mineralogy.
4. Stable isotope analyses.
5. Other chemical parameters.

Description

Element analyses of bulk sediments. Element analyses of bulk sediments involves determining the kind and quantity of elements present in sediment samples taken as a time series from a core. These data are subjected to a variety of multivariate analyses to characterize the data set in terms of origins of particular element groups. This information provides important insights into chemical processes (endogenic and authigenic (diagenetic)) operating within the local environment as well as processes (allogenic) that contribute materials from the surrounding region. These types of data are important for characterizing past climate because the endogenic-authigenic processes provide information about water chemistry that may be related to moisture balance whereas the allogenic record provides information about stream input and other factors that may characterize wet periods.

Carbonate mineralogy. Endogenic carbonate mineralogy is related to the Mg/Ca ratio of the water from which the carbonate precipitated. As lake water evaporates, the Mg/Ca ratio increases or conversely, as lake water is diluted or flushed, the ratio decreases resulting in a different suite of carbonate minerals. The expected mineral sequence from dilute water to concentrated water is low-Mg calcite, high-Mg calcite, aragonite (or dolomite), and monohydrocalcite. Thus, knowledge about the carbonate mineral sequence through a sedimentary deposit may provide evidence for wet and dry cycles. Moreover, biogenic carbonate, principally the shells of ostracodes or snails, may provide information about the temperature and salinity of the water in which the carbonate was precipitated. The Mg/Ca ratio of biogenic calcite is known to be closely related to the temperature at which the carbonate precipitated, whereas the Sr/Ca ratio appears to be related to the salinity of the water. Temperature and salinity are important climate indicators in climatically sensitive aquatic environments.

Noncarbonate mineralogy. Noncarbonate minerals such as salts and silica minerals (opals, clays) provide information about the composition of the parent body of water, about the diagenetic postdepositional environment, or

CONSULTATION DRAFT

both. The former provides information about moisture balance, whereas the latter provides an indication of the degree of alteration of a sedimentary unit.

Stable isotopes. Stable isotopes, principally of oxygen and carbon, but also of strontium, sulfur, deuterium/hydrogen, provide information about the source/temperature of precipitation, water salinity, water temperature, and other forms of environmental information. This information, as with aquatic microfossils, provides a means of evaluating the moisture balance or temperature of the atmosphere over the water body.

Other chemical parameters. Other types of geochemical analyses may prove necessary in some situations. Marsh sediments, for example, may be especially rich in organic compounds or other components not common in playas.

Methods and technical procedures

The methods and technical procedures for Activity 8.3.1.5.1.2.3 are given in the following table.

Method	Technical procedure		Date
	Number	Title	
Carbonate mineral analysis	TBD ^a (in preparation)	Quantitative x-ray diffraction analysis of carbonate minerals and quartz	TBD
Analyses of organics in lake, playa, and marsh sediments	TBD (in preparation)	A program to develop detailed technical procedures for the USGS quality assurance program of the NNWSI Project, to characterize and quantify organic matter biomarker contents of lake sediment samples	TBD
Textural and mineralogic analyses	TBD	Mineralogy of sediment samples	TBD
	TBD (in preparation)	Procedures for sedimentologic description of sediment cores	TBD
	TBD (in preparation)	Grain size analysis of sediment core samples	TBD

CONSULTATION DRAFT

Method	Technical procedure		Date
	Number	Title	
	TBD	Element analyses of bulk sediments	TBD
	TBD	Stable isotope analyses	TBD

^aTBD = to be determined.

8.3.1.5.1.2.4 Activity: Chronologic analyses of lake, playa, and marsh deposits

Objectives

The objective of this activity is to obtain an accurate, precise chronologic framework for the paleoclimatic information acquired in this study. Moreover, all age information should, whenever possible, be tested with other techniques to reduce uncertainties.

Parameters

The parameters for this activity are ages of biostratigraphic indicators and sediments using the following techniques: carbon-14, amino acid, thermoluminescent dates, uranium-series, uranium-trend, paleomagnetism, tephrochronology, fossils, and others.

Description

Carbon-14. Radiocarbon analyses will be conducted on organic rich sediments, on terrestrial organic matter deposited in aquatic sediments, or on biogenic carbonate using conventional or tandem accelerator methodologies. Radiocarbon can provide age information in the age range from modern to 50,000 yr before present, but is subject to decreasing confidence with decreasing sample size, increasing age, and errors due to contamination.

Amino acids. Amino acid analyses may be applied to well-preserved mollusc or ostracode shells. Particular amino acids are known to change from one state to another as a function of time and temperature. Thus when temperature is known to have been relatively constant, amino acid analyses may provide age, but when thermal histories are variable amino acid data may be used for relative age or as a correlation tool.

Thermoluminescent dating. This technique is in the experimental stage at this time, but may prove useful for dating aquatic sediments in the age range of 2,000 to 250,000 yr before present. The value of this method over most others is that it is usually not dependent on local geochemistry.

CONSULTATION DRAFT

Uranium-series. Uranium-series analyses are conducted largely on inorganic or biogenic carbonates. This method is useful for obtaining ages on materials that incorporate uranium but no thorium at the time of crystallization, and remain closed to uranium and its daughter products throughout their history. The age range of this method is from about 5,000 to approximately 350,000 yr before present.

Uranium-trend. Uranium-trend analyses will be conducted largely on surface sediments such as marsh outcrop or soil sequences. It may be applicable to playa cores under some circumstances. This method is an open-system dating method based on uranium-series decay and the migration of daughter products of U-238 through a soil or sediment column. The method is most effective on samples in the range of 60,000 to 600,000 yr.

Paleomagnetism. Paleomagnetic analyses will be applied to core and trench sediments to establish the remanent magnetism. Except for geologically short intervals, the past 700,000 yr has exhibited normal polarity. In most instances, the discovery of reversed polarity sediments indicates they were deposited before this date.

Tephrochronology. This method involves the comparison of the chemical and physical characteristics of volcanic ashes with those of ashes of known ages.

Fossils. The geologic history of many terrestrial and aquatic organisms are well known so that the occurrence of these organisms provides an age range for the sediment. Moreover, the timing of the expansion or contraction of biogeographic ranges for some organisms, largely rodents, is known so that the occurrence of such taxa in a particular area offers a more refined age than the geologic range of the species.

Other chronological methods. Techniques such as stratigraphic position, sediment accumulation rates, soil development, degree of weathering, or presence of artifacts may offer needed age estimates. Moreover, some forms of isotopic analyses, such as strontium isotopes, may provide a way of recognizing sediments deposited from different waters and thus offer a relative age.

Additional records that will be utilized include tree-ring data that have been collected in central and western Nevada as discussed in Chapter 5. These data will be interpreted to determine relationships between tree-ring widths and seasonal fluctuations in climate on the scale of 10 to 1,000 yr. This interpretation will be useful in the development of paleoclimatic transfer functions.

Methods and technical procedures

The methods and procedures for Activity 8.3.1.5.1.2.4 are given in the following table.

CONSULTATION DRAFT

Method	Technical procedure		Date
	Number	Title	
	(NWM-USGS-)		
Dating of lake, playa, and marsh deposits	GCP-06, R0	Potassium-argon dating	15 June 81
	GCP-01, R0	Radiometric-age data bank	15 June 81
	GCP-02, R1	Labeling, identi- fication and control of samples for geochemistry and isotope geology	20 Jan 88
	GCP-03, R0	Uranium-series dating	15 June 81
	GCP-04, R0	Uranium-trend dating	15 June 81
Dating of lake, playa and marsh deposits	GCP-05, R0	Radium, equivalent uranium, thorium, and potassium analysis by gamma-ray spectrometry	15 June 81
	GP-08, R0	Correlation of tephra by means of chemical analyses	19 Feb 86
	TBD ^a (in preparation)	Radiocarbon dating	TBD
	TBD	Amino acid	TBD
	TBD	Thermoluminescence	TBD

^aTBD = to be determined.

8.3.1.5.1.3 Study: Climatic implications of terrestrial paleoecology

This study will provide quantitative estimates of changes in climatic variables (e.g., precipitation and temperature) for the southern Great Basin. Plant macrofossils from pack rat middens will provide coverage for the last 50,000 yr (Activity 8.3.1.5.1.3.1), while fossil pollen from land plants recovered from cores of lacustral sediments will cover at least the last 150,000 yr (Activity 8.3.1.5.1.3.2). Transfer functions, response surfaces, or both will be developed through the statistical comparisons of modern

CONSULTATION DRAFT

climate to the vegetation data, and these equations will be used in the reconstructions of past climates from the paleovegetation data (Activity 8.3.1.5.1.3.3).

8.3.1.5.1.3.1 Activity: Analysis of pack rat middens

Objectives

The objective of this activity is to determine the nature, timing, duration, and magnitude of past vegetation change as recorded in plant macrofossil assemblages preserved in ancient pack rat middens.

Parameters

The parameters for this activity are

1. Macrofossil assemblages collected from pack rat middens in the southern Great Basin and surrounding region.
2. Radiocarbon age estimates.
3. Other data--vertebrates, insects, isotopic data.

Description

Pollen studies (discussed in Activity 8.3.1.5.1.3.2) are generally carried out in permanently wet environments, but pack rat midden analysis is restricted to the semiarid and arid deserts of western North America. In this method, past vegetation is reconstructed from plant remains preserved in middens deposited in rock cavities by rodents of the genus Neotoma (pack rats, wood rats, or trade rats). The plant remains can often be identified to the species level, and the assemblages are believed, based on the contents of modern middens, to represent vegetation growing within a radius of 30 m of the midden at the time of accumulation.

Pack-rat middens are collected by extracting kilogram-sized samples of material from different levels of the deposit. These are soaked in water to dissolve the cementing material and sieved to concentrate the plant remains (e.g., stems, needles, leaves, and seeds). When dry, the plant material is sorted and counted or weighed to produce a quantified record of the different plant taxa present.

Selected plant macrofossils or other materials from each midden are submitted for radiocarbon analysis. This dating method provides an estimate of the age of the midden assemblage, accurate to within a few hundred years. In instances where more precise dating is required, multiple samples from the same midden are submitted for radiocarbon dating. The paleobotanical data from the individual midden assemblages are compiled to create time series of vegetational change from a given area and vegetational setting. Replication of pack rat chronologies from sites with similar settings ensures that site-specific phenomena do not introduce bias into the interpretation of the data set.

CONSULTATION DRAFT

In addition to plant macrofossils, pack rat middens are rich sources of vertebrate and insect remains, pollen, and cellulose for isotopic investigations. The data may be analyzed to elucidate certain paleoclimatic signals. This activity will be carried out in conjunction with Activity 8.3.1.5.2.1.4 (analog recharge studies).

Methods and technical procedures

The methods and technical procedures for Activity 8.3.1.5.1.3.1 are given in the following table.

Method	Technical procedure		Date
	Number	Title	
Collection, analysis, and radiocarbon dating of pack rat midden macrofossil assemblages	TBD ^a (in preparation)	Pack rat midden quality assurance document	TBD

^aTBD = to be determined.

8.3.1.5.1.3.2 Activity: Analysis of pollen samples

Objectives

The objective of this activity is to determine the nature, timing, duration, and magnitude of past vegetation change as recorded in the stratigraphic record of fossil pollen grains.

Parameters

The parameters for this activity are

1. Pollen assemblages collected from lacustrine, marsh, and playa sediments (and other sedimentary deposits) in the southern Great Basin.
2. Radiocarbon dates, tephrochronology, and other chronological markers.

Description

Studies of fossil pollen in stratified deposits have been used extensively to reconstruct fluctuations in temperature and precipitation over the last 20,000 yr. The applicability of the method has been limited in the western United States by the relative scarcity of bogs and small lakes, the

CONSULTATION DRAFT

optimal settings for most types of pollen studies. However, paleoclimatological insights have been gained from studies of the fossil pollen contained in sediments deposited in western pluvial lakes, alpine lakes, caves, rock shelters, and alluvium. Pollen records, in general, provide quasi-continuous records of regional vegetational change. While the majority of these studies are restricted to the Holocene, palynological studies of pluvial lake, marsh, and playa sediments also provide information over the period of 10 to several hundreds of thousand years ago.

Pollen is extracted from samples by dissolving unwanted mineral and organic matter in the sample with strong acids and bases. The pollen is comparatively resistant and will remain and become concentrated after dissolution. The pollen is stained to enhance its microstructural detail and mounted on microscope slides for examination. Pollen grains of known plant taxa are identified, tabulated, and plotted stratigraphically according to absolute concentration (per gram or cubic centimeter of sediment) or relative percentages. The stratigraphic plots are interpreted in terms of increasing or decreasing amounts of plant taxa responsible for the various pollen types, taking into account the relative pollen production of individual plant groups, the ease by which pollen is distributed, and the processes by which it is incorporated into the sediment and preserved.

In some instances, pollen studies will be conducted at the same sites as those for paleolacustrine investigations (Study 8.3.1.5.1.2), because lake sediments may contain well preserved pollen and represent more or less continuous deposition. However, because of exposure and oxidation, playa deposits may be unsuitable for pollen analysis. Pack rat middens also contain pollen, particularly from the local vegetation surrounding the midden site, and its analysis can be helpful in determining the nature of the pollen rain (the pollen coming from and falling on any region) in areas where lakes and marshes are few.

Methods and technical procedures

The methods and procedures for Activity 8.3.1.5.1.3.2 are given in the following table.

Method	Technical procedure		
	Number	Title	Date
Collection and analysis of pollen deposited in lake sediment	TBD ^a (in preparation)	A program to develop needed technical procedures for the USGS quality assurance program of the NNWSI Project for paleoclimate pollen activity	TBD

^aTBD = to be determined.

CONSULTATION DRAFT

8.3.1.5.1.3.3 Activity: Determination of vegetation-climate relationships

Objectives

The objectives of this activity are to translate the vegetational records provided by pack rat midden and palynological investigations and available dendroclimatological data into quantitative estimates of past climatic variables.

Parameters

The parameters for this activity are

1. Vegetation-climate, pollen-climate response surfaces, or both.
2. Pollen-climate transfer functions.

Description

Palynological and pack rat midden studies together provide a regional network of time series of vegetational change spanning the last few tens of thousands of years. Much of the evidence for past climatic variations comes from such paleoecological records of past vegetation. The interpretation of these paleoecological records in climatic terms requires information on the modern relationships between vegetation and climate. Given the understanding of such relationships, and with certain assumptions, it is possible to infer the nature of the climatic variations responsible for the vegetation changes recorded by the fossil evidence.

Relationships between modern vegetation and climate are also required for the validation of climate simulation models. To judge the ability of the model to simulate correctly the past climate, modern vegetation-climate relationships are used to transform model simulations of past climates into estimates of past vegetation; these can then be compared with the observed fossil record.

There are two related approaches for constructing statistical relationships between modern vegetation and climate data: (1) a transfer function approach in which individual climate variables are expressed as a function of several vegetation predictor variables (e.g., the percentages of different pollen types); and (2) a response function approach in which the relative abundances (or the presence or absence) of individual taxa are expressed as nonlinear functions of one or more environmental variables.

The transfer function approach usually makes use of a multiple regression analysis to construct a relationship between a particular climate variable and a number of predictor variables, which are generally the percentages of individual pollen types. In practice, a data set of paired observations of modern surface pollen samples and climate is required for calibration of the equation. The resulting equation is then applied to fossil pollen data to interpret them in climatic terms.

CONSULTATION DRAFT

In the response function approach, the relative abundance or probability of occurrence of different taxa is expressed as a nonlinear (usually polynomial) function of one or more environmental variables. The resulting functions are usually displayed as "response surfaces" that show how the abundance or probabilities vary in the space defined by the environmental variables. For relative abundance data, the response functions are fit using linear regression, while for presence-absence data, the surfaces are fit using logistic regression.

Because response functions illustrate the environmental preferences of different taxa, they can provide guidance in the qualitative interpretation of fossil data in climatic terms. Quantitative reconstruction is possible as well, using response functions of several taxa to determine the environmental conditions necessary to give rise to a particular fossil assemblage.

Application of response functions for climate model validation is relatively straightforward. The relative abundance or the presence or absence of different taxa can be simulated by applying response functions to the values of climate variables simulated by climate models. The simulated vegetation variables can then be compared with the observed. In a typical example, the climate model would be set up to simulate some specific paleoclimate, and the simulated vegetation would be compared with the observed fossil record.

Methods and technical procedures

The methods and procedures for Activity 8.3.1.5.1.3.3 are given in the following table.

Method	Technical procedure		
	Number	Title	Date
Translation of paleobotanic data into a climate signal using statistical techniques: transfer functions and response surfaces from lake and playa sediment data	TBD ^a	Transfer functions and response surfaces	TBD
Preparation of "synoptic snapshots" of climate extremes	TBD (in preparation)	Synoptic snapshots of climate	TBD

^aTBD = to be determined.

CONSULTATION DRAFT

8.3.1.5.1.4 Study: Analysis of the paleoenvironmental history of the Yucca Mountain region

The objective of this study is to evaluate the paleoenvironmental record at Yucca Mountain and surroundings in the light of the inferred paleoclimate history of the southern Great Basin. It also provides information to distinguish between effects resulting from surficial processes, as opposed to tectonic activity, and to evaluate the age of tectonic events. The chronology of the erosional and depositional responses to climatic changes at Yucca Mountain will be used to cross-check and supplement the reconstruction of paleoclimate. A detailed paleoenvironmental history is needed to distinguish short- and long-term tectonic effects from local climatic controls on surficial processes. Therefore, dated deposits in this study will be used to constrain ages and recurrence intervals of fault movements.

The paleoenvironmental history of the Yucca Mountain region is a record consisting of surficial deposits and landforms resulting from a combination of specific climatic and tectonic conditions. Surficial processes involving weathering, water, and wind are dominantly controlled by climatic conditions. In surficial deposits with well-constrained ages, specific indicators of paleoclimate can be compared with the regional paleoclimatic history. Less specific indicators of paleoclimate at Yucca Mountain can be reconstructed from soils of different ages and from depositional environments of surficial deposits.

Although the characteristics of the diverse arid-region surficial deposits at Yucca Mountain and surroundings do not allow the precise determination of such climatic parameters as temperature and precipitation, they contain a valuable record of paleoclimate data pertinent to the site itself. The surficial deposits provide a tool for understanding how the Yucca Mountain region has responded to Quaternary climatic episodes and climatic change in the southern Great Basin, in that they suggest that the types and intensities of different erosional and depositional processes have changed throughout the Quaternary. To ascertain whether the climatic responses at Yucca Mountain have been synchronous with those of the rest of the Great Basin, it will be necessary to compare the paleoenvironmental record at Yucca Mountain (from surficial deposits data) with the regional paleoclimate history. If the responses have not been synchronous, it will be necessary to examine other factors besides regional paleoclimate to explain the history of erosional and depositional response at Yucca Mountain. Thus, the paleoenvironmental history serves as both a cross-check on the regional paleoclimate history, as well as a means by which the effect of past hydrologic and erosional episodes upon the Yucca Mountain landscape can be quantified. In addition, this history bears on assessing the influence of local and regional tectonic processes on the surficial processes operating at Yucca Mountain.

The modeling of soil properties at Yucca Mountain will result in a definition of the relation of the properties of late Holocene soils to modern climatic parameters, the comparison of paleoclimate scenarios to soil properties, and the quantification of soil development over time for use as a dating technique. Investigation of modern soils forming under soil moisture conditions similar to wetter paleoclimates at Yucca Mountain will result in the ability to characterize soil properties resulting from past pluvial

CONSULTATION DRAFT

conditions. Mapping of the surficial deposits of the Yucca Mountain area will aid in the evaluation of the influence of paleoclimate on their genesis and the history of erosion and landform development. Reconstruction of the eolian history of Yucca Mountain will result in an understanding of the role of eolian deposition and erosion in the paleoenvironment and aid in defining the Quaternary paleoclimates at Yucca Mountain.

8.3.1.5.1.4.1 Activity: Modeling of soil properties in the Yucca Mountain region

Objectives

The objectives of this activity are to

1. Determine the relations among properties of late Holocene soils and modern climatic parameters.
2. Compare properties of early Holocene and Pleistocene soils to paleoclimatic models that are reconstructed from other lines of evidence, such as paleolimnology and terrestrial paleoecology, as a check on these models.
3. Frame climatic scenarios as a function of the depth, distribution, and quantity of pedogenic carbonate and other soil parameters.
4. Quantify rates of soil development in specific climates for use as a dating tool for Quaternary deposits and ages of fault movements.

Parameters

The parameters for this activity are

1. Soil morphology and physical and chemical properties of Holocene and Pleistocene soils formed on a variety of parent material lithologies, under modern climates similar to Yucca Mountain at present and during the latest glacial maximum (the Pahute Mesa and Tonopah climatic analog sites).
2. The understanding of how airborne dust contributes to the development of soils on parent materials containing a high proportion of gravels.
3. Physical and chemical analyses of dust.
4. Field measurements of soil partial pressure of carbon dioxide (pCO_2) and available water-holding capacity (AWC).
5. Movement and composition of soil solutions as determined by lysimeter studies.

CONSULTATION DRAFT

6. Rates of carbonate translocation in soils of known composition, texture, and pCO_2 , under different climatic regimes and rates of accumulation of dust.
7. Rates of soil development from physical and chemical properties of dated soils, including field-described properties (color, texture, structure, clay content, and consistency) and laboratory measured properties (clay mineralogy, major elements, bulk density, soluble salts, carbonates, and extractable iron oxides).
8. Ages of soils at study sites (using cation ratios of rock varnish, potassium-argon, radiocarbon, uranium-trend, uranium-series, and thermoluminescence dating techniques). Experimental isotopic dating techniques such as beryllium-10 and chlorine-36, may be used if they are proved useful and reliable.

Description

An important aim of this activity will be to compare theoretical carbonate distributions, resulting from computer modeling under various simulated climatic conditions, with real carbonate distributions in sampled soils. This will result in a line of evidence that can be used as a check on paleoclimate models as reconstructed from other lines of evidence (paleolimnology and terrestrial paleoecology). Another aim of the activity is to apply the rates of soil development calculated from the physical and chemical properties of dated soils to undated soils in order to estimate the ages of undated soils. These ages will be important in the estimations of ages of Quaternary deposits and fault movements at Yucca Mountain and surroundings.

Soil properties are a function of time and climate. In particular, the distribution and concentration of calcium carbonate and other soluble salts are linked to temperature and precipitation. This relation can be quantified if other factors such as the available water-holding capacity (AWC) of the soil and the composition and influx rate of dust are known. Computer modeling of soils under various climatic regimes can simulate the distribution (depth) and concentration of carbonate in soils. This information, when compared with the movement of carbonate as measured by lysimeters and with carbonate distribution in soils of known age, will permit the evaluation and cross-checking of paleoclimate models proposed for the Yucca Mountain area from paleolimnology and terrestrial paleoecology. Paleoclimate models can be modified if the actual distribution of soil carbonates conflicts with distributions predicted by these models.

Rates of soil development will be calculated for dated surficial deposits, using measured physical and chemical properties. The result of these calculations will be the quantification of the development of some soil properties over time. Knowing the rates at which certain features of a soil develop will allow the dating of previously undated soils, through the examination and measurement of the same properties and the application of known rates. It is expected that this method of dating surficial deposits will also be applied to bracketing ages of fault movement in the Yucca Mountain area.

CONSULTATION DRAFT

Backhoe trenches will be excavated in soils developed on surficial deposits of known or inferred ages. The sites will be classified according to deposit age. Soil profiles at a minimum of two sites for each age category will be sampled and described. Sites under consideration in California include Silver Lake and the Cima volcanic field. These particular sites may provide information to the soil modeling effort. They are localities that are characterized by relatively complete stratigraphic sections that contain multiple well-developed paleosols of various ages. The chronology of the paleosols at these localities is well established by radiometric age dates and may provide a relatively complete record of soil development during Quaternary time. Proposed sites in Nevada include Kyle Canyon, Beatty, Fortymile Wash, and a location near Tonopah.

A regional network of dust traps has been set up in a variety of climatic, lithologic, and geomorphic settings. The purpose of the network is to collect airborne dust in marble traps to simulate dust additions to soils developed in gravelly parent materials. Samples will be collected at least once a year. Dust-collection data are required for input for the computer modeling of carbonate translocation and are not available in the existing soils literature.

Soil and dust samples will be analyzed in the laboratory for physical and chemical properties related to climate and age. The properties that may be measured include, but are not limited to, (1) particle size distribution, (2) organic matter content, (3) carbonate and silica content, (4) soluble salts, (5) extractable chemistry, (6) major and minor element chemistry, (7) soil water, (8) density, (9) mineralogy, and (10) morphology.

Available water-holding capacity and pCO_2 is measured in gravelly desert soils of a variety of ages at various locations in the vicinity of Yucca Mountain. These data are required as input for the computer modeling of ground-water transport of carbonate and are not available in the existing soils literature. Also, the movement and composition of soil solutions in soils near Yucca Mountain will be measured by lysimeters. This data will be compared with the movement of soil solutions predicted by computer modeling.

Therefore, a computer program has been developed to model the movement of carbonates in solution through soils of varying texture and AWC under varying climatic conditions. The program will be used to simulate carbonate development in soils according to the paleoclimatic conditions developed from paleolimnologic and terrestrial paleoecologic evidence. Simulated soil conditions will be compared with real soil conditions at Yucca Mountain to evaluate the paleoclimate history and, if necessary, modify it.

Methods and technical procedures

The methods and procedures for Activity 8.3.1.5.1.4.1 are given in the following table.

CONSULTATION DRAFT

Method	Technical procedure		
	Number	Title	Date
	(NWM-USGS-)		
Trenching, sampling, and description of soils	GP-07, R0	Geologic trenching studies	14 Aug 84
	GP-17, R0	Describing and sampling soils in the field	19 Feb 86
Dust trap sampling	TBD ^a	Dust trap sampling	TBD
Laboratory analyses of soil physical and chemical properties	TBD	Physical, chemical, and mineralogical properties of soils and surficial deposits	TBD
Field measurements of soil pCO ₂ and available water ₂ -holding capacity (AWC)	TBD	Field measurements of soil pCO ₂ and AWC	TBD
Development of computer model for the transport of carbonate by ground water	TBD	Computer modeling of soil carbonate translocation	TBD
Lysimeter studies of soil leachates	TBD	Lysimeter collection of soil leachates	TBD
Rates of soil development	TBD	Determination of rates of soil development	TBD
Dating of soils (cation ratio, thermoluminescence, radio-carbon, uranium-trend, uranium-series, and potassium-argon dating method techniques)	GCP-01, R0	Radiometric-age data bank	15 June 81
	GCP-02, R1	Labeling, identification and control of geochronology samples for geochemistry and isotope geology	4 Apr 81
	GCP-03, R0	Uranium-series dating	15 June 81
	GCP-04, R0	Uranium-trend dating	15 June 81
	GCP-06, R0	Potassium-argon dating	15 June 81
	TBD	Cation ratio (desert varnish) dating	TBD
	TBD	Thermoluminescence	TBD

CONSULTATION DRAFT

Method	Technical procedure		Date
	Number	Title	
	TBD (in preparation)	Radiocarbon dating	TBD

^aTBD = to be determined.

8.3.1.5.1.4.2 Activity: Soil moisture analog study

Objectives

The objective of this activity is to characterize physical, chemical, and mineralogic properties of selected soils at Pahute Mesa and areas near Tonopah, which have formed under conditions similar to those that may have existed at Yucca Mountain during pluvial conditions of Pleistocene glacial climatic cycles. Comparison of these soils with Yucca Mountain paleosols will allow inferences to be made concerning climate conditions that existed at Yucca Mountain at various times throughout the Quaternary.

Parameters

The parameters for this activity are

1. Chief characteristics of soil including profiles, color, structure, texture, stone content, secondary clay, calcium carbonate, secondary silica, consistency, and plasticity.
2. Chief physical properties of surficial deposits including lithology, stone content, texture, color, and depositional features.
3. Physical, chemical, and mineralogic properties of soils including, but not limited to, particle size distribution, calcium carbonate content, amorphous silica, amounts and types of soluble salts, clay mineralogy, amounts and types of extractable iron, bulk density, and soil water chemistry.
4. Ages of soils and surficial deposits.

Description

The modern soils of Pahute Mesa and areas near Tonopah in the Kawich Range, Toiyabe National Forest, have formed under approximately the same moisture levels as Yucca Mountain and the surrounding region during pluvial conditions of Pleistocene glacial climatic cycles. This activity is aimed at defining the physical, chemical, and mineralogic characteristics of soils in the region that are now developing under wetter conditions from those that

CONSULTATION DRAFT

presently exist at Yucca Mountain. Comparison of the properties of analog soils with those of similar soils at Yucca Mountain will provide a means of evaluating the paleoclimate history of the Yucca Mountain area.

Backhoe trenches will be excavated at selected sites at Pahute Mesa and near Tonopah to facilitate soil description and sampling. At each trench, the soil profile will be photographed and described, with the description focusing on the depth, form, and relative abundance of secondary calcium carbonate and amorphous silica. The amounts and forms of carbonate, amorphous silica, and soluble salts in soils and soil water are important to the interpretation of present and past soil moisture conditions on Pahute Mesa and other analog study areas.

Soil and soil water samples will be collected in the trenches. These samples will be analyzed in the laboratory to determine physical, chemical, and mineralogic properties. These properties may include, but are not limited to, (1) particle size distribution, (2) bulk density, (3) clay mineralogy, (4) abundance of secondary carbonate, (5) amount of amorphous silica, and (6) amounts and types of soluble salts and extractable iron oxides. Soil water chemistry will also be determined in the laboratory.

Dating of soils and surficial deposits, in conjunction with the calculation of soil profile summations (for carbonate, amorphous silica, secondary clay, and extractable iron oxides), will allow the determination of rates of accumulation of secondary constituents. Dating techniques will include an appropriate combination of uranium-series, uranium-trend, radiocarbon, thermoluminescence, and cation ratio dating.

Methods and technical procedures

The methods and procedures for Activity 8.3.1.5.1.4.2 are given in the following table.

Method	Technical procedure		
	Number	Title	Date
	(NWM-USGS-)		
Description of soil morphology in trenches, collection of soil samples in trenches	GP-07, RO	Geologic trenching studies	14 Aug 84
	GP-17, RO	Describing and sampling soils in the field	19 Feb 86
Collection of soil water samples	TBD ^a	Collection of soil water	TBD
Laboratory analyses of soil physical, chemical, and mineralogic properties	TBD	Physical, chemical, and mineralogical properties of soils	TBD

CONSULTATION DRAFT

Method	Number	Technical procedure	
		Title	Date
Laboratory chemical analysis of soil water	GP-21	Chemical analysis of soil water	TBD
Dating of soils	GCP-02, R1	Labeling, identification and control of samples for geo-chemistry and isotope geology	20 Jan 87
	GCP-03, R0	Uranium-series dating	15 June 81
	GCP-04, R0	Uranium-trend dating	15 June 81
	TBD	Cation ratio (desert varnish) dating	TBD
	TBD	Thermoluminescence	TBD
	TBD (in preparation)	Radiocarbon dating	TBD

^aTBD = to be determined.

8.3.1.5.1.4.3 Activity: Surficial deposits mapping of the Yucca Mountain area

Objectives

The objectives of this activity are to

1. Determine the distribution, age, genesis, soil properties, and physical properties of surficial deposits at Yucca Mountain and surroundings.
2. Evaluate the influences of climate and tectonics on the genesis of surficial deposits.
3. Provide a map of surficial deposits for facility placement planning, geomorphic studies, engineering property studies, and surface infiltration studies.

CONSULTATION DRAFT

Parameters

Among the parameters under consideration are the following:

1. Distribution, spatial relationships, and thicknesses of the various types of surficial deposits (e.g., fluvial, eolian, and colluvial).
2. Chief physical properties of surficial deposits, including lithology, stone content, particle size distribution, bulk density, soil moisture content, texture, color, and depositional features.
3. Chemical and mineralogical properties of surficial deposits and soils may include, but are not limited to, clay mineralogy, calcium carbonate content, amount of amorphous silica, amounts and types of soluble salts, amounts and types of extractable iron, and soil water chemistry.
4. Chief soil characteristics, including the profile, color, structure, texture, stone content, secondary clay amounts, calcium carbonate content, secondary silica content, consistency, and plasticity.
5. Ages of surficial deposits and soils.
6. Interpreted paleotemperatures during carbonate deposition.

Description

The distribution, spatial relationships, and thicknesses of the various surficial deposits of the Yucca Mountain area will be defined; the definition will be aimed at identifying the geomorphic settings of the various deposits (e.g., fluvial, eolian, and colluvial), the areal extents and proportion of each type of deposit within the region, their thicknesses, and their vertical and horizontal stratigraphic relations. The distribution of surficial deposits will be determined by mapping the deposits on aerial photographs and possibly on satellite imagery. The contacts of the deposits will be verified in the field by examining trenches and natural exposures. Field descriptions of surficial deposits and soils will focus upon characteristics and parameters that will aid in determining their age and genesis, as well as the influences of past climate and tectonics. The area of investigation is shown in Figure 8.3.1.5-5. This activity will be carried out in conjunction with Activity 8.3.1.6.1.1.1 (development of geomorphic map of Yucca Mountain). This activity will also interface and complement the work done in Section 8.3.1.14.2 (studies to provide soil and rock properties at potential locations of surface facilities).

To supplement the mapping (particularly with regard to deposit thicknesses, but more importantly for the description and sampling of the surficial deposits and soils), shallow trenches will be excavated by backhoe, bulldozer, or both at key sites. In addition to the detailed description of the stratigraphy, soil morphology, and other physical characteristics of the surficial deposits, samples will be collected for physical, chemical, and mineralogic analysis and for stable isotope analysis and dating. Another supplemental procedure for the mapping will be the compilation and interpretation of lithologic logs of previously drilled shallow drillholes to

CONSULTATION DRAFT

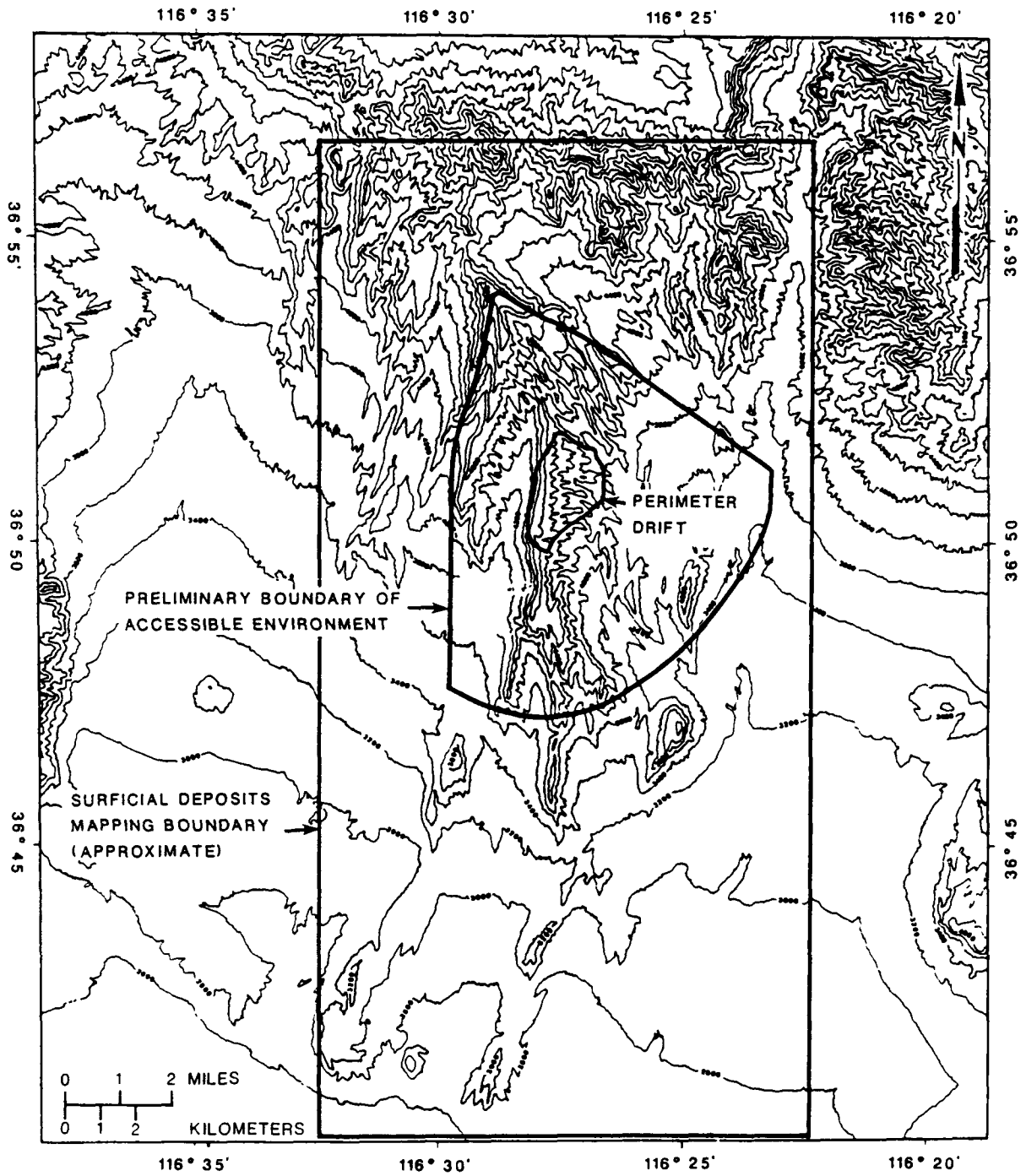

Figure 8.3.1.5-5. Approximate boundaries of Yucca Mountain surficial deposits mapping

CONSULTATION DRAFT

determine the thickness and other physical properties of surficial deposits encountered in drilling. This information will be correlated with results of the mapping and trenching procedures.

Soil water samples will be collected at selected sites for chemical analysis. Chemical data for modern soil water will aid in determining the paleoclimatic implications of the relative abundance, form, and distribution of secondary calcium carbonate and amorphous silica in the various surficial deposits. Also, this data will aid in applying the findings of the soil moisture analog study to the interpretation of paleosoil moisture conditions in the Yucca Mountain area.

Laboratory analysis of surficial deposits and soils will be conducted to determine a variety of physical, chemical, and mineralogical properties. These properties may include, but are not limited to, (1) particle size distribution, (2) bulk density, (3) soil moisture content, (4) clay mineralogy, (5) calcium carbonate content, (6) amounts of amorphous silica, and (7) amounts and types of soluble salts and extractable iron. Data from these analyses will provide a basis for characterizing key physical, chemical, and mineralogical properties of the surficial deposits and soils, and will aid in the determination of their genesis and relative ages.

The surficial deposits will also be dated to aid in correlation of depositional events with Pleistocene glacial and interglacial climatic cycles and the periods of transition between these cycles. Dating techniques will include uranium-series, uranium-trend, radiocarbon, thermoluminescence, and cation ratio dating. Dating will also contribute to the effort to correlate paleoecological evidence with the paleoenvironmental (erosional and depositional) history of Yucca Mountain area.

The uranium-series dating technique has been a useful tool in estimating the ages of crystallization of secondary carbonates. This technique can potentially be used on any materials that incorporate uranium but no thorium at the time of crystallization, and remain closed to uranium and its daughter products throughout their history (Bradley, 1985).

Preliminary analysis (Knauss, 1981) suggests that Quaternary secondary silica should be an ideal material for uranium-series disequilibrium methods. Dates on amorphous (opaline) silica would provide minimum limiting ages for their host sediments, and dates on buried opals would provide maximum limiting ages for overlying sediments. Secondary carbonates occur in a wide variety of forms in the Yucca Mountain area. Many have developed in surficial deposits; others occur as root casts in eolian-alluvial-colluvial "sand-ramp" deposits, as fracture-fill materials, and as throughflow seep deposits. Two important characteristics of these carbonates make them suitable materials for deriving paleoclimatic information: (1) they may have been deposited by meteoric waters and thus would reflect in part the temperature of crystallization in the near-surface environment, and (2) they are datable by uranium-series disequilibrium methods. Uranium is quite soluble in meteoric waters that pass through uranium-bearing minerals, especially in near-surface environments characterized by oxidizing conditions. Trace amounts of uranium are thus carried through soils, unconsolidated materials in water, or both and coprecipitated with calcium carbonate. In contrast, thorium is characterized by extreme insolubility in near-surface environments and thus does not

CONSULTATION DRAFT

coprecipitate with uranium because it is not leached from thorium-bearing minerals. This is significant because, with time, the amount of thorium-230 will increase by radioactive decay of uranium-234. The ratios of the activity of thorium-230 to its parent uranium-234 and its grandparent uranium-238 are used to calculate the date of crystallization of the carbonate. At present, this method is useful back to about 350,000 yr.

Uranium-trend dating is an open-system dating method based on uranium-series decay and the migration of daughter products of uranium-238 through a soil or sediment column. In the Yucca Mountain area, the uranium-trend dating method has thus far been limited mainly to alluvial deposits because they are the most extensive Quaternary sediments. Because one of the pertinent questions to be answered in geologic investigations of Yucca Mountain is the rate of hillslope erosion (Section 8.3.1.6), accurate dating of colluvial deposits is desirable. Dating of eolian sediments is also useful, because such deposits are significant from a paleoclimatic point of view. If uranium-trend dating is feasible on colluvial and eolian deposits, the derived ages should be consistent with the relative ages. Such a test is only a partial check on the suitability of the method, because consistent relative ages may result but may be incorrect in terms of absolute age. A further check is provided by the linearity of the uranium-trend plots; plots that show poor linearity indicate that the material is unsuitable for dating and little confidence can be placed in the derived absolute ages. Good linearity and consistent relative ages strongly suggest correct absolute ages. Alluvial deposits in this area generally show excellent linearity on uranium-trend plots. A final and more rigorous test of the suitability of the method would be to compare derived uranium-trend ages with independent absolute dating methods such as conventional closed-system uranium-series dates on secondary carbonates that occur in the same deposits or potassium-argon dates on volcanic rocks that underlie the deposits. This uranium-trend method is most effective on samples in the range of 60,000 to 600,000 yr (Rosholt et al., 1985).

Isotopic analyses of secondary carbonates will be performed to determine paleotemperatures from proportions of stable isotopes. The results of these analyses will include isotopic composition of secondary carbonates (oxygen-16 to oxygen-18 and carbon-13 to carbon-12 ratios), differences between crystallization temperatures of secondary carbonates and Holocene average temperatures of crystallization, and dates of crystallization of secondary carbonates. One of the primary factors controlling the oxygen isotope composition of secondary carbonates in near-surface environments is temperature of crystallization. Theoretical and empirical studies have shown that the ratio of oxygen-18 to oxygen-16 varies systematically with temperature in carbonates if the oxygen isotope compositions of the source waters are similar. Departure of carbonate crystallization temperatures from the present value can be determined using oxygen isotope compositions of Pleistocene samples in comparison with isotope composition of Holocene samples. Paleotemperatures thus determined can be very useful in testing the hypothesis that pluvial periods were caused at least in part by cooler temperatures and reduced rates of evapotranspiration. In addition, since there is a regular change in oxygen isotope composition of carbonates with temperature, the magnitude of temperature change can be estimated. Empirical studies have shown that carbon isotopic composition of soil carbonates is controlled to a great extent by the type of plant community. Because temperature is one of the controlling

CONSULTATION DRAFT

factors in plant geography, determination of the former vegetation type will serve as an independent, qualitative check on the paleotemperature determinations.

Erosional landforms ("nivation basins") above 2,200 m in the high mountain ranges near the Nevada Test Site reflect the past occurrence of perennial snowfields (Dohrenwend, 1984). Although the time of formation of these features is not yet known with certainty, they are presumably of Late Wisconsin age. The occurrence of perennial snowfields provides evidence on the past climate at the upper reaches of the recharge areas for Yucca Mountain. Investigations of these features will focus on their geographic and elevational distribution, their age, and the paleoclimatic inferences that can be drawn from their occurrence.

Methods and technical procedures

The methods and procedures for Activity 8.3.1.5.1.4.3 are given in the following table.

Method	Technical procedure		Date
	Number	Title	
	(NWM-USGS-)		
Mapping and interpretation of aerial photographs and satellite imagery; field mapping and verification	GP-01, RO	Geologic mapping	1 Mar 83
Excavation of shallow trenches at key sites for the description and sampling of surficial deposits and soils	GP-07, RO	Geologic trenching studies	14 Aug 84
Compilation and interpretation of lithologic logs of previously drilled shallow boreholes	GP-02, RO	Subsurface investigations	1 Mar 83
Collection of soil water samples	TBD ^a	Soil water collection	TBD
Laboratory analyses of surficial deposits and soils for physical, chemical, and mineralogic properties	TBD	Physical, chemical, and mineralogic properties of soils and surficial deposits	TBD

CONSULTATION DRAFT

Method	Technical procedure		Date
	Number	Title	
Laboratory chemical analysis of soil water	GP-21	Chemical analysis of soil water	TBD
Isotopic dating of surficial deposits and soil	GCP-01, R0	Radiometric-age data bank	15 June 81
	GCP-02, R1	Labeling, identification, and control of samples for geochemistry and isotope geology	20 Jan 87
	GCP-03, R0	Uranium-series dating	15 June 81
	GCP-04, R0	Uranium-trend dating	15 June 81
	TBD	Cation ratio (desert varnish) dating	TBD
	TBD	Thermoluminescence	TBD
Stable isotope analysis	TBD (in preparation)	Radiocarbon dating	TBD
	TBD (in preparation)	Stable isotope analysis	TBD
Testing of uranium-series and uranium-trend dating on new geologic materials	GCP-03, R0	Uranium-series dating	15 June 81
	GCP-04, R0	Uranium-trend dating	15 June 81

^aTBD = to be determined.

8.3.1.5.1.4.4 Activity: Eolian history of the Yucca Mountain region

Objectives

The objectives of this activity are

1. Document eolian erosion and deposition in the Yucca Mountain area during the last 750,000 yr.
2. Determine paleoenvironmental conditions during times of eolian deposition and intervening times of surface stability and soil formation.

CONSULTATION DRAFT

3. Determine source areas of sand and silt.

Parameters

The parameters for this activity are

1. Age of eolian sediments and soils developed on eolian deposits by uranium-series methods, thermoluminescence, and volcanic ash identification.
2. Textural characteristics of sediments.
3. Mineralogy of sediments.
4. Paleowind directions--directly determined from faceted bedrock surfaces, or determined from cross-bedding azimuth measurements of dune deposits.
5. Paleowind velocities--indirectly determined by measuring platelet spacing on the surface of abraded quartz grains.
6. Concentrations of thorium, titanium, zirconium, yttrium, and niobium in alluvial and eolian sands and in alluvial and eolian silts.

Description

Eolian deposits are widespread in the Yucca Mountain area. Thick deposits of sand have been blown against Fran Ridge, Busted Butte, and southern parts of Yucca Mountain, and veneers of eolian silt mantle nearly all flat and gently sloping surfaces and ridge tops in the area. These deposits range in age from at least 740,000 yr to only a few thousand years old. Thus, the great spatial and temporal distribution of eolian deposition and erosion, and the intervening episodes of surface stability and soil formation, record a long history of climatically influenced conditions at Yucca Mountain. Dating of eolian deposits is also important to the reconstruction of Quaternary fault movements at Yucca Mountain, because several major north-south trending faults offset these eolian deposits.

Eolian sands will be dated primarily by identifying volcanic ashes that are interbedded in sand ramps, and by uranium-series dating of secondary carbonates in the soils developed on these deposits. Paleoenvironmental conditions that have well-constrained ages can then be compared with other paleoclimatic reconstructions, most notably the lacustrine records developed under Activity 8.3.1.5.1.2.1. Because the paleoclimate record derived from pack rat middens in the Yucca Mountain area is limited to the age range of radiocarbon dating (about 50,000 yr before present), dated eolian deposits are one of the few sensitive paleoclimatic indicators available for reconstructing paleoenvironments older than 40,000 yr.

The Bishop ash has already been observed in the sand ramps, indicating that eolian deposition in the Yucca Mountain region began before 740,000 yr before present (Izett, 1982). Volcanic ashes of Lava Creek (610,000 yr before present) and Lathrop Wells basaltic core (the late Quaternary) occur in the Yucca Mountain area and may occur in the sand ramps.

CONSULTATION DRAFT

Uranium-series dating of the sand ramps is possible because these sediments contain secondary carbonates of two distinct types. The first type takes the form of rhizoliths or root casts; these features form as sheaths and casts of plant roots in sandy calcareous sediments. The presence of a plant cover implies that the sediments have been stabilized and that little or no deposition is taking place. The second type of carbonate deposit found in the sand ramps is laminar calcrete. Studies conducted elsewhere in the southwestern United States indicate that most laminar calcretes are of pedogenic origin and take a considerable amount of time to form after stabilization of the geomorphic surface (Gile et al., 1965). Uranium-series dating of rhizoliths yields a close minimum age for the time of stabilization of a sand ramp surface. Uranium-series dating of laminar calcretes yields a minimum age for the underlying sediments, but also a maximum age for overlying sediments. Thus, by dating both types of carbonates, bracketing uranium-series dates can be obtained for many of the sand ramp sediments; for the uppermost units, close minimum ages can be obtained.

Fine-grained eolian silt is an ideal geologic material for dating by thermoluminescence analysis over a time range of the last 100,000 yr. Silt-rich eolian deposits mantle gently dipping surfaces and may represent one or more episodes of eolian deposition. Preliminary thermoluminescence dating of vesicular A horizons from the Yucca Mountain area indicates that deposition of the fine silt fraction took place in the mid-Holocene (Whitney et al., 1986).

The distribution and thickness of these dated eolian deposits, both sand and silt, will be mapped to aid in the reconstruction of paleowind directions and in the identification of sediment source areas. Regional wind directions can be reconstructed from the position of dunes with respect to topographic barriers, and by regional comparison of the geometry, cross-bedding azimuths, and thickness of the deposits. Paleowind directions will also be measured from the orientation of wind-abraded bedrock surfaces on hills and mountains.

The geochemistry of immobile trace elements will be studied in eolian sediments to identify sediment source areas. Sand and silt-rich soil A horizons, typically with vesicular structure, are common surface horizons in soils of arid regions, including most soils in the Yucca Mountain area. Investigators who have studied these features in other parts of the southwestern United States have concluded that many such features are (1) primarily eolian in origin and (2) of Holocene age (McFadden et al., 1986). Particle size analyses of vesicular A horizons from the Yucca Mountain area indicate that these features have modal sizes in the fine sand and fine silt fractions, suggesting that (1) the features are probably eolian and (2) two sources of sediment may be involved, one local (fine sands) and one distant (fine silts). If the source of the fine silts can be identified, it may be possible to reconstruct the mid-Holocene paleowind pattern. The most likely candidates as distant sources for the fine silts are unvegetated playa surfaces found in the structural basins of southern Nevada. Identification of the source basin or basins is possible by analysis of playa fine silts and vesicular A horizon fine silts for immobile trace element concentrations. The term immobile here refers to elements that are usually chemically immobile under surface conditions. Such elements (thorium, titanium, zirconium, yttrium, and niobium) are not leached from crystal lattice positions under subaerial conditions and hence can serve as signatures for basins with

CONSULTATION DRAFT

distinctive lithologies. The five trace elements to be measured are those that have been used most extensively by igneous petrologists in classifications of volcanic rocks of different origins; their use here is appropriate because most of the basins in southern Nevada receive sediments eroded primarily from Tertiary volcanic rocks. In a similar fashion, local sources of the fine sands found in the vesicular A horizons can be identified using the same trace elements. Collectively, the data should identify the sources of sediment in soil A horizons and allow reconstruction of local and synoptic-scale paleowind patterns in the mid-Holocene.

Investigations of sand mineralogy will be performed to augment both sediment source identification and to search for volcanic ashes. Textural characteristics of the eolian deposits will be analyzed to aid in reconstructing eolian conditions and to determine how much sand has been reworked by alluvial processes. Bimodal grain-size distributions, for example, exist in the silt mantles, indicating two sources of sediment in the deposit.

Terrestrial paleoecologic studies will be done on pollen, teeth, bones, rootcasts, and burrows where such evidence is found and can be determined to indicate local paleoenvironmental conditions. Tests will be done to determine whether or not the pollen preserved in sand ramp sands and interbedded soils is of local or regional origin. This information can then be compared with paleoenvironmental information derived from macrofossil studies of local pack rat middens (Study 8.3.1.5.1.3). Soils analyses undertaken as part of the surficial deposits mapping of Yucca Mountain (see description of Activity 8.3.1.5.1.4.3) will yield paleotemperature information from oxygen isotopic analyses, and ranges of paleotemperatures and precipitation based on modeling of several soil properties (Activity 8.3.1.5.1.4.1).

Paleowind velocities will be measured indirectly by studying the surface textures of eolian quartz grains with a scanning electron microscope. The frosting of quartz grains is known to be caused by abrasion, and at the microscopic level this frosting is seen to be the formation of a series of parallel plates. The spacing between individual plates is related to the velocity of the wind that last transported the grains. Measurements of plate spacing on grains from different age deposits will allow comparison of paleowind velocities with those of present winds.

Methods and technical procedures

The methods and procedures for Activity 8.3.1.5.1.4.4 are given in the following table.

CONSULTATION DRAFT

Method	Technical procedure		Date
	Number	Title	
	(NWM-USGS-)		
Dating of eolian sands by identification of volcanic ash	GP-08, RO	Correlation of tephra by means of chemical analyses	17 Feb 86
Uranium-series dating of sand ramp secondary carbonates	GCP-03, RO	Uranium-series dating	15 June 81
Thermoluminescence dating of fine eolian silt	TBD ^a	Thermoluminescence	TBD
Mapping of distribution and thickness of eolian silt	GP-01, RO	Geologic mapping	1 Mar 83
Immobile trace element geochemistry of eolian sediments	TBD	Trace element geochemistry	TBD
Textural and mineralogic characteristics of eolian sand	TBD	Textural analyses	TBD
	TBD	Mineralogic analyses	TBD
Terrestrial paleo-ecological studies	TBD	Terrestrial paleoecology	TBD
Paleowind velocity analysis	TBD	Paleowind velocity analysis	TBD

^aTBD = to be determined.

8.3.1.5.1.5 Study: Paleoclimate-paleoenvironmental synthesis

This study consists of one activity and will compare the paleoclimatic estimates from the various proxy data sets and provide data syntheses in the formats required for future climate and paleohydrology investigations.

CONSULTATION DRAFT

8.3.1.5.1.5.1 Activity: Paleoclimate-paleoenvironmental synthesis

Objectives

The objective of this activity is to provide summaries of the paleoclimatic data in formats that can be utilized by investigations of future climatic changes and paleohydrology.

Parameters

The parameters for this activity are

1. Synoptic snapshots of climatic conditions during key time periods in the past.
2. Time series (chronologies) of changes in climatic variables (e.g., precipitation and temperature).
3. Estimates of magnitude, timing, and duration of major past periods of high effective moisture.

Description

Paleoclimatic data will be used (1) in future climate investigations to validate numerical climate models, (2) to establish the relationships between past periods of high levels of effective moisture in southern Nevada and global climate states, and (3) to provide input into paleohydrological models. The paleoclimatic estimates from paleolacustrine investigations, terrestrial paleoecology, and paleoenvironmental investigations must be compared and synthesized into the forms required by these other studies.

The numerical climate models will be constructed on the basis of modern climatic data, and paleoclimatic investigations will provide independent data for model validation. This exercise will require mapped arrays of paleoclimatic estimates (synoptic snapshots) for key time periods in the past (primarily over the last 50,000 yr). The periods will be selected to provide a range of differing boundary conditions, such as global ice maxima versus minima, and will demonstrate the validity and sensitivity of the models to changes in these conditions.

A second approach to predicting aspects of future climatic variations in southern Nevada will involve identifying the global climate states (e.g., glacials, interglacials, and interstadials) that accompanied regional periods of high effective moisture. Estimates of the characteristics, magnitudes, and durations of such periods will provide guidance in estimating the climatic infiltration parameters that would occur at Yucca Mountain, if, for example, a glacial climate occurred in the next 10,000 to 100,000 yr. Another aspect of these empirical studies will be to identify (if possible) periodic components in past climatic variations to provide a basis for estimating the timing of future changes. This approach will require time-series data of variations in climatic parameters.

Mapped summaries of paleoclimatic estimates will be compared with paleohydrologic data to establish the relationships between climatic phenomena and

CONSULTATION DRAFT

changes in hydrologic parameters. These maps will be similar to those required for model validations, but will be centered on Yucca Mountain and will be on finer, smaller spatial and temporal scales. Ongoing scientific work that bears directly on these modeling efforts is being carried out under the COHMAP project (Webb et al., 1987), a joint venture including Brown University, the University of Wisconsin, and the National Center for Atmospheric Research (NCAR). The COHMAP project includes mapping of general circulation model (GCM) simulated climates (from the NCAR Community Climate Model) at 3,000-yr intervals back to full glacial. The simulations are then compared with conditions inferred from paleoclimate indicators (e.g., fossil pollen). The results of the COHMAP project are expected to be extremely useful in implementing the site characterization plans, and COHMAP activities will be integrated with the SCP activities wherever appropriate.

8.3.1.5.1.6 Study: Characterization of the future regional climate and environments

The objective of this study is to estimate values for climatic parameters for the Yucca Mountain area over the next 100,000 yr, with special emphasis on the next 10,000 yr. The values for these parameters will be used in the hydrologic modeling of the ground-water regime at Yucca Mountain (Investigation 8.3.1.5.2) and in the investigation of the effects of future climate on erosion at Yucca Mountain (Investigation 8.3.1.6.2). Estimates for future precipitation, temperature, evapotranspiration, and other parameters will result from the modeling of certain climate scenarios expected to occur in the southern Great Basin over the next 100,000 yr.

Modeling of future climate requires the development of a procedure for quantitatively evaluating the characteristics of future climate scenarios. This study will employ a dual approach to modeling: a numerical approach (Activities 8.3.1.5.1.6.1 through 8.3.1.5.1.6.3) and an empirical approach (Activity 8.3.1.5.1.6.4). Both approaches first require the establishment of an integrated time series of paleoclimate change and the selection of expected future climate scenarios based on the nature and timing of climate scenarios in the Quaternary. In the numerical modeling approach, a linked global-regional numerical model will be employed to calculate the future meteorological parameters. The regional model will use boundary conditions for future scenarios as derived from a global climate model as well as from paleoclimate evidence from corresponding similar episodes in the Quaternary. In the empirical modeling approach, values of climate parameters for future scenarios will be estimated from evidence in the paleoclimate record for corresponding similar episodes in the Quaternary.

Both the numerical and the empirical approaches to modeling future climate are descriptive methods. They are two different ways of describing the meteorology of future climate scenarios, and both are based on the paleoclimate history of the region. This history will include the timing, duration, and meteorologic nature of Quaternary climatic episodes. The prehistorical record of climate must extend far enough back into the past and be dated with enough precision to allow the reconstruction of an integrated time series of paleoclimate from paleolacustrine, terrestrial paleoecologic, and paleoenvironmental evidence (Study 8.3.1.5.1.5).

CONSULTATION DRAFT

As an integral part of this study, two advisory panels will be formed. These panels, made up of specialists in areas of climate modeling, will be used to assess the specific details of the two climate modeling efforts (i.e., the global modeling and the regional modeling, if the feasibility study determines that regional modeling is appropriate), with particular attention to be given to (1) the development of criteria to evaluate the different models available and the different techniques used, (2) the establishment of boundary conditions, (3) the expected and realistically attainable output from each model, and (4) the ability of the two models to interact with each other. The potential use of the advisory panels is identified in the following discussion of the activities to be conducted under this study.

8.3.1.5.1.6.1 Activity: Global climate modeling

Objectives

The objectives of this activity are to

1. Identify and estimate factors controlling global climate.
 - a. Develop a sequence of "snapshots" of possible climate scenarios at intervals of up to 1,000 yr over the next 10,000 yr.
 - b. Develop a set of anticipated global climate scenarios over the next 100,000 yr.
2. Compute the configuration and extent of ice sheets at regular intervals of time over the next 100,000 yr to determine the effects of such ice volume changes upon the climatic system.
3. Provide boundary conditions, including precipitation, temperature, cloud cover, evapotranspiration, and wind velocity for regional climate models through the use of general circulation models.

Parameters

The output from the global climate modeling, to be used as boundary conditions for the regional modeling includes means and ranges of the following parameters:

1. Surface temperature.
2. Cumulative precipitation rate.
3. Condensed moisture.
4. Fractional cloud amount.
5. Averaged solar flux absorbed at surface.
6. Averaged solar flux absorbed by earth and atmosphere.
7. Averaged infrared flux upward at surface.
8. Averaged longwave flux at top of atmosphere.
9. Averaged total albedo of surface and atmosphere.
10. Shortwave heating rate.
11. Longwave heating rate.

CONSULTATION DRAFT

12. Convective temperature change.
13. Sensible heat flux at surface.
14. Latent heat flux at surface.
15. Wind velocity.

Description

The paleoenvironmental record for the Quaternary Period suggests that significant variations in climate have occurred in the past and are likely to occur in the future. Modeling future global and regional climate will help determine whether such variations in climate can significantly affect the proposed repository at Yucca Mountain. General circulation models (GCMs) can provide three-dimensional simulations of the atmosphere at too coarse a spatial resolution to provide meaningful results for specific sites. Regional mesoscale models are capable of disaggregating GCM output to represent explicitly the physical processes that govern the hydrologic balance. Therefore, the goal of this study is to link a GCM with a regional model to predict future climate. The details of how this is to be achieved are shown in Figure 8.3.1.5-6.

The prediction of future global climate rests largely on calculation of extreme climatic conditions (scenarios) that can be anticipated to occur in the future. A coupled ice sheet-energy balance modulus expected to be used to identify the scenarios pertinent to hydrology that are associated with repository performance. At present, the following scenarios have been identified as being of concern:

1. Natural variability under modern conditions.
2. Glacial periods that may correspond to pluvial conditions in the southern Great Basin.
3. A "super" glacial and resulting conditions in the southern Great Basin.
4. A "super" interglacial, in which increases in carbon dioxide and other trace gases lead to significant global warming.
5. A "super-long" period of changed climate, that, by virtue of its duration, could adversely affect site performance.

In addition, future climate for the next 10,000 yr will be modeled in time intervals of up to 1,000 yr in duration. Additional scenarios and time periods will be run as required by results of the energy balance model runs or other sources.

The best known changes in the global climate system during the Quaternary Period accompanied the growth and decay of major ice sheets. These glacial-interglacial cycles have been shown to correlate with the variations in orbital parameters of the earth (i.e., longitude of perihelion, obliquity, and eccentricity (Hays et al., 1976)).

One goal of climate modeling is to demonstrate that these ice volume variations follow deductively from a simple set of mathematical statements or

CONSULTATION DRAFT

forcing functions. Computer codes have been developed to simulate climate change based upon these forcing functions. These climate drivers will provide (1) estimates of the probability of certain climate scenarios, (2) timing of climate scenarios of concern, and (3) rough estimates of future climate states.

The success of such a modeling effort rests upon the degree to which model output agrees with the paleoclimate record. A key output parameter from climate drivers is the volume of glacier ice present on the earth at a given time. Therefore, global ice volume will be analyzed for over the range of values believed to have occurred during the Quaternary (as discussed in Section 5.2). Validation of the climate driver simulations will be based upon oxygen isotope records (found in cores of oceanic sediments), which are considered to reflect the total volume of ice on the earth's surface at a given time.

Various climate drivers have been developed to simulate future climate states at intervals of up to 1,000 yr for the first 10,000 yr and for the four scenarios mentioned earlier. The process of selection and implementation of the drivers will be reviewed by the advisory panel chosen from specialists in the field of climate modeling (as discussed in the previous section). At a minimum, the following models will be considered: (1) the Imbrie and Imbrie (1980) global ice volume forecast based upon orbital parameters and calibrated with oxygen isotope data, (2) the Hasselmann (1976) "red noise" model of climate change which makes stochastic forecasts of global ice volume, (3) Pollard's (1983) model of ice volume linked to orbital parameters and glacio-isostatic affects, (4) the astronomical climate index model developed by Kukla et al. (1981), (5) a spectral model based upon the observed spectrum of the oxygen-isotope ratio in the Northeastern Pacific Ocean, and (6) the Saltzman (Saltzman and Sutera, 1984) physically motivated model of the integrated climate system.

The next step in the modeling activity (as shown in Figure 8.3.1.5-6) involves estimating configurations of each major ice sheet on the globe at regular intervals of time over the next 100,000 yr. Although orbital variations may induce glacial-interglacial cycles, one of the important factors helping to maintain ice ages is the extensive ice sheets which increase the albedo of the earth. Therefore, a two-dimensional ice sheet model will be developed in this activity and will be calibrated to output from the global climate drivers.

General circulation models (GCMs) are sensitive to the volume and distribution of glacial ice covering the earth as well as variations in the orbital parameters of the earth. These scenarios of interest will be determined by an expert panel after examination of the simulated evolution of boundary conditions as produced by the climate-driver models possibly augmented by an energy-balance model. The scenarios of interest may not be limited to extreme boundary conditions, but may include situations which, because of their temporal persistence or other characteristics, are potentially relevant to site performance. Therefore, output from the climate driver and ice sheet models will be used as boundary conditions for GCM runs at the time periods or for the scenarios of interest (as shown in Figure 8.3.1.5-6). Additional boundary conditions for runs of GCMs include the locations and elevations of continental areas, the locations and elevations

CLASSES OF MODEL

WORK

OUTPUT

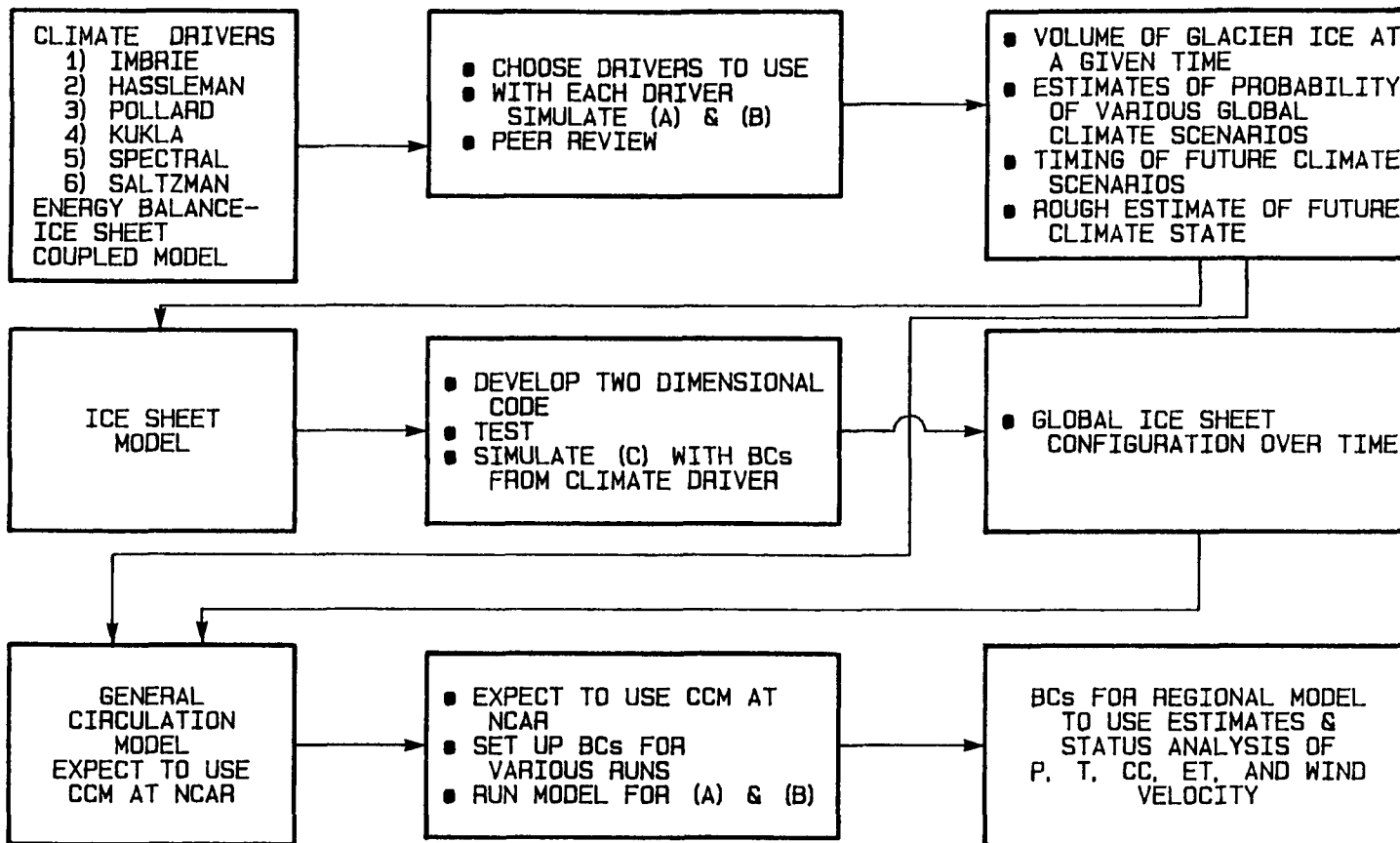

8.3.1.5-66

CONSULTATION DRAFT

- CCM - COMMUNITY CLIMATE MODEL
- NCAR - NATIONAL CENTER FOR ATMOSPHERIC RESEARCH
- BC - BOUNDARY CONDITION
- P - PRECIPITATION
- T - TEMPERATURE
- CC - CLOUD COVER
- ET - EVAPOTRANSPIRATION

- (A) SNAPSHOTS OF CLIMATE AT UP TO 1,000-yr INTERVALS FOR 10,000 yr
- (B) SCENARIOS
 - 1 - PRESENT (NATURAL VARIABILITY)
 - 2 - GLACIAL PERIODS THAT MAY CREATE "PLUVIAL" CONDITIONS IN THE SOUTHERN GREAT BASIN
 - 3 - SUPER GLACIAL-PLUVIAL
 - 4 - SUPER INTERGLACIAL
 - 5 - SUPER-LONG PERIOD OF CHANGED CLIMATE
- (C) ICE SHEET CONFIGURATION AT 1,000 yr INTERVALS FOR 10,000 yr

Figure 8.3.1.5-6. Flow of information for global climate modeling activity.

CONSULTATION DRAFT

of continental ice, the locations and temperature of sea ice, surface albedo, and sea-surface temperature.

Since uncertainties exist in specifying or computing factors such as CO₂ level or sea surface temperatures, the model simulations will include a sensitivity analysis of climate response to a plausible range of variables that may contribute to global climate change.

Present plans for the GCM modeling will use the CCM at the National Center for Atmospheric Research. This approach has been approved by the advisory panel mentioned earlier. A version of the CCM under development includes an oceanic circulation component and should result in documented, well-tested codes by FY 1989.

Initial model simulations are designed to determine the sensitivity of climate to uncertainties in the specified boundary conditions. These simulations will be done with fixed sea surface temperatures. Future simulations will be designed to incorporate the full seasonal cycle. Output data will include estimates of precipitation, temperature, cloud cover, evapotranspiration and wind velocity. Regional processors will be developed to manipulate the data that surrounds the Yucca Mountain site in coordination with the regional modeling activity. Input to the regional models will be in the form of boundary conditions.

Published model results (CLIMAP Project Members, 1981) for the last glacial maximum will provide a set of benchmarks in the early stages of the activity. Some examination of the validity of the model results can be obtained from the comparisons to the various time horizons represented in the geologic record.

Verification, validation, and benchmarking of all the computer codes and mathematical and numerical models will follow NRC guidelines for documentation of codes (NRC, 1983a). The basis of these efforts will be an examination of the ability of the coded procedures to reproduce accurately the modern circulation patterns and those reconstructed for the last glacial maximum and other time horizons (where data are available). All model results will be reviewed by the advisory panel at regular intervals during the characterization process.

Methods and technical procedures

The methods and procedures for Activity 8.3.1.5.1.6.1 are given in the following table.

Method	Technical procedure		
	Number	Title	Date
Software development for global climate modeling	SMP-301	Determination of software classification	19 May 86

CONSULTATION DRAFT

Method	Technical procedure		Date
	Number	Title	
	SMP-302	Software development specification preparation and approval	19 May 86
	SMP-303	Final internal development review of computer code and documentation	19 May 86
	SMP-304	Computer code acceptance testing	19 May 86
	SMP-305	Computer code configuration control	19 May 86
	SMP-306	Computer code and documentation change control	19 May 86
	SMP-307	Computer code verification and/or validation	19 May 86
	SMP-308	Utility code documentation, control, testing and use	19 May 86
	SMP-309	Computer code application control	19 May 86
	SMP-310	Magnetic media protection and control	19 May 86
	SMP-311	Computer software transfer	19 May 86
	SMP-312	Control of acquired data bases	19 May 86

8.3.1.5.1.6.2 Activity: Regional climate modeling

Objectives

The objective of this activity is to establish the feasibility of using a regional scale numerical climate model for predicting future climatic conditions at Yucca Mountain. If this task is accomplished, the model will be calibrated against modern climatic data and validated with paleoclimatic data.

CONSULTATION DRAFT

Parameters

The parameters for this activity are

1. Calibration of a regional-scale numerical climatic model (with historic data).
2. Validation of a regional-scale model (with paleoclimatic data).

Description

A feasibility study will be initiated to evaluate the applicability of numerical regional climate modeling in accomplishing the climate prediction requirements of the NNWSI Project within appropriate time and cost constraints. Regional numerical modeling is used to describe the meteorology of expected future climate scenarios resulting from the interpretation of the paleoclimate record. A numerical regional model is a mathematical description of the dynamics of the earth's atmospheric circulation, based upon the equations of fluid flow and specific boundary conditions. The model describes how the earth's atmosphere responds to imposed boundary conditions, with the output of the model being in the form of calculated values of meteorological parameters (precipitation, temperature, etc.) for discrete geographic areas--rectangles created by gridding the earth's surface parallel to latitude and longitude. Reducing grid size increases the spatial resolution of the model at the cost of increased computational load. The practicality of small grids will be studied.

The feasibility of a regional modeling approach would first be established by demonstrating that current climate conditions can be adequately simulated over the southern Great Basin. This validation exercise would emphasize amounts and seasonal patterning of precipitation and other surface climatological conditions. If it is successful in these simulations, the model would be tested against Quaternary paleoclimatic conditions for periods with adequate observational characterization of surface climate. If these efforts were also successful, the model would be deemed suitable for generating future climate scenarios for the proposed repository site at Yucca Mountain and would be so employed.

The development of a numerical atmospheric model will be pursued only if the proposed feasibility study indicates that the numerical modeling approach would be an effective and timely method of accomplishing the NNWSI Project climate prediction objectives. If the feasibility study does not produce encouraging results in terms of the resolution desired and computational efficiency regarding regional numerical modeling, as determined from criteria established by an expert panel, then the characterization of future regional climate and environments will be based essentially on the empirical modeling approach.

Methods and technical procedures

The methods and procedures for Activity 8.3.1.5.1.6.2 are given in the following table.

CONSULTATION DRAFT

Method	Technical procedure		Date
	Number	Title	
Projection of expected future climate scenarios	TBD ^a	TBD	TBD
Regional numerical modeling of future climate scenarios	TBD	TBD	TBD

^aTBD = to be determined.

8.3.1.5.1.6.3 Activity: Linked global-regional climate modeling

Objectives

The objectives of this activity are to

1. Formulate reasonable hypotheses for scenarios of future climate in the southern Great Basin and Yucca Mountain over the next 100,000 yr, with emphasis on the next 10,000 yr.
2. Model meteorological parameters of expected climate scenarios for the southern Great Basin.
3. Use the quantitative meteorologic descriptions resulting from the modeling of future climate scenarios to derive measurements of climate parameters to be used in hydrologic modeling of the Yucca Mountain area and in investigating the effects of climate on erosion at Yucca Mountain.

Parameters

The parameters for this activity are

1. Estimates of the nature, timing, and probability of occurrence of future climate scenarios.
2. Meteorologic parameters of expected future climate scenarios: average annual rainfall, seasonal distribution of rainfall, type and intensity of storms, average annual snowfall, distribution and duration of snow cover, rapidity of snowmelt, evapotranspiration, cloud cover, and temperature.
3. The values of meteorologic parameters over requisite time spans, to be used in the hydrologic modeling of Yucca Mountain and in erosion investigations.

CONSULTATION DRAFT

Description

Following the testing period for the regional climate model, it will be decided if such a modeling approach is within the time and cost constraints of the NNWSI Project. In addition, the defensibility of the model on its own will be analyzed as well as its ability to link with the global climate model. If the regional numerical model receives approval from an expert panel, it will be linked with a GCM (Section 8.3.1.5.1.6.1) to simulate future climatic conditions at Yucca Mountain. The outputs of the global future climate modeling activity will be used as boundary conditions on regional climate model runs to simulate future climate conditions at Yucca Mountain.

Methods and technical procedures

The methods and procedures for Activity 8.3.1.5.1.6.3 are given in the following table.

Method	Technical procedure		
	Number	Title	Date
Compilation of meteorological parameter values for input to hydrologic modeling	TBD ^a	TBD	TBD

^aTBD = to be determined.

8.3.1.5.1.6.4 Activity: Empirical climate modeling

Objectives

The objectives of this activity are to

1. Formulate reasonable hypotheses for scenarios of future climate in the southern Great Basin and Yucca Mountain over the next 100,000 yr, with emphasis on the next 10,000 yr.
2. Model meteorological parameters of expected climate scenarios for the southern Great Basin.
3. Use the quantitative meteorologic descriptions resulting from the modeling of future climate scenarios to derive measurements of climate parameters to be used in hydrologic modeling of the Yucca Mountain area and in investigating the effects of climate on erosion at Yucca Mountain.

CONSULTATION DRAFT

Parameters

The parameters for this activity are

1. Estimates of the nature, timing, and probability of occurrence of future climate scenarios.
2. Meteorologic parameters of expected future climate scenarios over requisite time spans: average annual rainfall, seasonal distribution of rainfall, type and intensity of storms, average annual snowfall, distribution and duration of snow cover, rapidity of snowmelt, evapotranspiration, cloud cover, wind speed and direction, and temperature.

Description

The empirical approach to climate modeling will be the direct application of meteorological values estimated for paleoclimate episodes to the description of analogous scenarios expected to occur in the future. For a given scenario, values of precipitation, temperature, and other parameters would be estimated directly from the paleolacustrine, terrestrial paleoecologic, and paleoenvironmental evidence. A simplistic example would be the following: statistical examination of the paleoclimate record might show that there is a moderate-to-high probability of another period of higher-than-present precipitation and lower-than-present temperatures (a pluvial), spanning several thousand years, occurring at some time between 80,000 and 100,000 yr from the present. To characterize the meteorology of this expected episode, the values of meteorologic parameters for prior pluvial episodes are assembled from the physical evidence of the paleoclimate record. The averages, seasonality, ranges, and areas of uncertainty for the parameters are synthesized in a form usable as input for hydrologic modeling. It should be noted that this approach of directly applying paleoclimate data to expected future scenarios is based directly on physical evidence, and on the assumption that climatic episodes within the next 100,000 yr in the southern Great Basin will resemble events in the Quaternary paleoclimate history of the area. The record of past climatic variations can thus provide a guide to the range of climatic conditions foreseeable in the future, providing that the large-scale controls of climate remain similar to those that prevailed in the past. The increase of CO₂ concentrations in the atmosphere in the future (due to the burning of² fossil fuels, etc.) makes it likely that the large-scale controls of climate in the future may differ from those experienced during the Quaternary. As a result, numerical approaches to the prediction of future climate may be required to supplement the empirical methods.

The time series of paleoclimate will then be statistically examined for possible periodic components in climatic variation, including an examination for the presence of astronomical forcing of atmospheric circulation (the influence of changes in the earth's orbital relations to the sun on global air mass circulation). The present state of our knowledge of Great Basin climate history, as evidenced by the highstands of paleolake systems, suggests periodic components in climatic episodes of higher-than-present effective moisture in the Great Basin. Should this be confirmed statistically, it will then be possible to apply this periodic forcing function to

CONSULTATION DRAFT

estimating the timing of possible future pluvial episodes over the next 100,000 yr. This exercise will be aided by the fact that the variations in orbital parameters (eccentricity, obliquity, and precession) governing astronomical forcing can be estimated over the next 10,000 to 100,000 yr, and thus changes in insolation in that period are predictable.

If a periodicity in the climate record can be established, a sequence of expected future climate scenarios can be formulated for the next 100,000 yr, possibly accompanied by estimates of probabilities of occurrence for different climatic scenarios over this period. Should a periodicity not be clearly established, it will become necessary to use an alternative approach to estimating the timing of future climate scenarios. Such an approach would likely be a statistical description of the probabilities of certain climate scenarios recurring over the next 100,000 yr.

Methods and technical procedures

The method and procedure for Activity 8.3.1.5.1.6.4 is given in the following table.

Method	Technical procedure		
	Number	Title	Date
Synthesis of a time series of paleoclimate history	TBD ^a	TBD	TBD

^aTBD = to be determined.

8.3.1.5.1.7 Application of results

The information derived from the studies and activities of the plans described previously will be used in the following areas of site characterization, repository design, and performance assessment:

Characterization program,
information need, issue
or investigation

Subject

- | | |
|-------|---|
| 1.1.1 | Site information needed for calculations
(Section 8.3.5.13.1) |
| 1.1.3 | Computational models for release scenario
classes (Section 8.3.5.13.3) |
| 1.8 | NRC siting criteria (Section 8.3.5.17) |

CONSULTATION DRAFT

Characterization program,
information need, issue
or investigation

Subject

1.9a	Higher level findings--postclosure (Section 8.3.5.18)
8.3.1.2.1	Regional hydrologic system
8.3.1.2.2	Site unsaturated zone hydrologic system
8.3.1.2.3	Site saturated zone hydrologic system
8.3.1.5.2	Climate effects on hydrology
8.3.1.6.2	Climate effects on erosion
8.3.1.12	Meteorology program

8.3.1.5.1.8 Schedule and milestones

Investigation 8.3.1.5.1 contains six studies: 8.3.1.5.1.1 (characterization of modern regional climate), 8.3.1.5.1.2 (paleoclimate study: lake, playa, marsh deposits), 8.3.1.5.1.3 (climatic implications of terrestrial paleoecology), 8.3.1.5.1.4 (analysis of the paleoenvironmental history of the Yucca Mountain region), 8.3.1.5.1.5 (paleoclimate-paleoenvironmental synthesis), and 8.3.1.5.1.6 (characterization of the future regional climate and environments). In the figure that follows, the schedule information for these studies is presented in the form of timelines. The timelines extend from implementation of the approved study plans to the issuance of the final products associated with the study. Summary schedule information for this investigation can be found in Section 8.5.1.1.

One of the studies in this investigation is ongoing (8.3.1.5.1.4). Three of the studies (8.3.1.5.1.1, 8.3.1.5.1.2, and 8.3.1.5.1.3) are scheduled to begin during the first year of site characterization. The remaining two activities are scheduled to begin during the second (Study 8.3.1.5.1.6) and third (Study 8.3.1.5.1.5) years of site characterization.

The data collection, analysis, and modeling in this investigation will proceed in parallel with geohydrology, performance, and design activities and will interface with them in an iterative fashion. The characterization of future regional climate will provide input to Study 8.3.1.5.2.2 (characterization of future regional hydrology due to climatic change), as well as support the development of models of the unsaturated and saturated zones and the surface water system in the geohydrology program (Section 8.3.1.2). Future climatic changes that may alter the hydrologic regime will contribute to predictions of radionuclide transport in Issue 1.1 (total system performance evaluations of seal characteristics (Section 8.3.3.2), and evaluation of waste package characteristics (Section 8.3.4.2). This investigation also provides input to the geohydrology, erosion, surface characteristics, and

CONSULTATION DRAFT

preclosure hydrology programs (Sections 8.3.1.2, 8.3.1.6, 8.3.1.14, and 8.3.1.16, respectively).

The studies in this investigation are not seriously constrained by other program elements and can begin when the study plans are approved.

The study numbers and titles corresponding to the timelines are shown on the left of the following figure. The points shown on the timelines represent major events or important milestones associated with the study. Solid lines represent study durations, and dashed lines represent interfaces. The data on input and output at the interfaces are shown by circles.

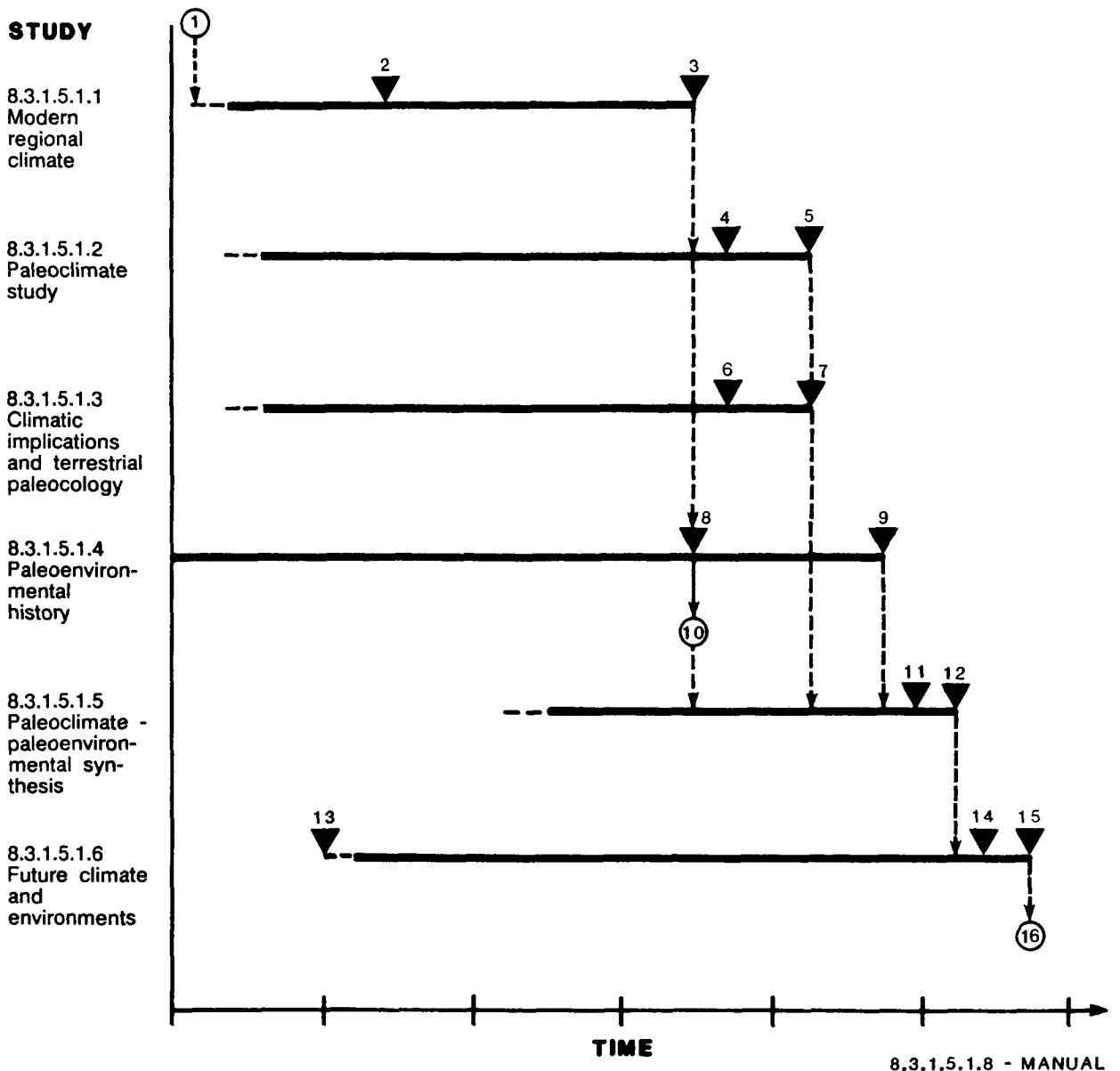

CONSULTATION DRAFT

The points on the timeline and the data input and output at the interfaces are described in the following table:

<u>Point number</u>	<u>Description</u>
1	Data received from meteorology program (Section 8.3.1.12) and geohydrology program (Section 8.3.1.2).
2	Milestone P725. Report available on synoptic climate of Yucca Mountain.
3	Milestone P101. Report available on characterization of the present regional climate and environment.
4	Reports available on paleontology, stratigraphy/sedimentology, geochemistry, and chronology of lake, playa, and marsh sediments near Yucca Mountain (Milestones Z265, Z266, Z267, and Z268).
5	Milestone Q039. Report available on lake, playa, and marsh sediments and their implications for paleoclimate at Yucca Mountain.
6	Milestone Z269. Report available on the evaluation of pack-rat middens in the Yucca Mountain region.
7	Milestone Q040. Report available on climatic implications of terrestrial paleoecology.
8	Milestone M698. Report available on the preliminary evaluation of paleoenvironment of Yucca Mountain. Milestone M892. Final 1:24,000 surface deposits map of the Yucca Mountain region available. Milestone P782. Final 1:12,000 scale map of site available.
9	Milestone Z272. Report on the synthesis of the paleoenvironmental history of the Yucca Mountain region.
10	Input to Study 8.3.1.17.4.6 (Quaternary faulting within the site area).
11	Milestone M395. Report available on Quaternary history of Yucca Mountain.
12	Milestone M366. Define Quaternary climate of Yucca Mountain.
13	Reports available on feasibility studies of regional climate modeling and global/regional modeling. (Milestones Z276 and Z277).

CONSULTATION DRAFT

<u>Point number</u>	<u>Description</u>
14	Milestone Z278. Report available on feasibility of empirical climate modeling approach.
15	Milestone P104. Report available on future climate as predicted from models based on the nature and rates of change in climatic conditions.
16	Input available for Study 8.3.1.5.2.2 (characterization of the future regional hydrology due to climatic changes).

8.3.1.5.2 Investigation: Studies to provide the information required on potential effects of future climatic conditions on hydrologic characteristics

Technical basis for obtaining the information

Link to the technical data chapters and applicable support documents

The following sections of the SCP data chapters provide a technical summary of existing data relevant to this investigation:

<u>SCP section</u>	<u>Subject</u>
3.7.4	Paleohydrology (regional)
3.9.8	Paleohydrology (site)
5.2.1	Paleoclimatology
5.2.2	Future climatic variation
5.2.3	Site paleoclimatic investigations

Parameters

The following parameters will be measured, estimated, or calculated as a result of the site studies planned as part of this investigation:

1. Relationship between climate and infiltration.
2. Past and future surface water characteristics--locations, frequency, and hydraulic properties of past and future flood events.
3. Past and future unsaturated-zone hydrologic characteristics--hydrochemical characteristics as an indication of past hydrology and prediction of future ground-water flow conditions.
4. Past and future saturated-zone hydrologic characteristics--water table altitude, and recharge and discharge locations and rates.

Other site studies that provide information that support the determination of the previous parameters include the following:

CONSULTATION DRAFT

<u>SCP section</u>	<u>Study</u>
8.3.1.2.1.2	Characterization of the regional surface water (present-day surface-water conditions)
8.3.1.2	Characterization of the regional ground-water flow system (present-day regional geohydrology)
8.3.1.2	Regional hydrologic system synthesis and modeling (present-day regional hydrology)
8.3.1.2	Characterization of unsaturated zone infiltration (present-day infiltration at the site)
8.3.1.2.2.3	Characterization of percolation in the unsaturated zone (present-day unsaturated-zone flux at the site)
8.3.1.2.2.8	Hydrochemical characterization of the unsaturated zone (present-day unsaturated-zone flux at the site)
8.3.1.2.2.9	Unsaturated zone flow and transport modeling
8.3.1.2.2.10	Unsaturated zone system analysis and integration (present-day unsaturated zone geohydrology)
8.3.1.2.3.1	Characterization of the saturated zone ground-water flow system (present-day saturated zone geohydrology)
8.3.1.2.3.2	Characterization of the site saturated zone hydrochemistry
8.3.1.2.3.3	Saturated zone hydrologic system synthesis and modeling (present-day saturated zone geohydrology)
8.3.1.5.1.1	Characterization of the modern regional climate (present-day regional climatic conditions)
8.3.1.5.1.2	Regional paleolimnologic studies (past regional climatic conditions)
8.3.1.5.1.3	Regional terrestrial paleoecologic studies (past regional climatic conditions)
8.3.1.5.1.4	Analysis of paleoenvironmental history of the Yucca Mountain region (past environments at the site)
8.3.1.5.1.6	Characterization of the future regional climate and environments (future climatic conditions at the site)
8.3.1.16.1.1	Site flood and debris hazards studies (present-day flood potential at the site)

CONSULTATION DRAFT

Purpose and objectives of the investigation

This investigation (8.3.1.5.2) provides information to help satisfy performance and design Issues 1.1, 1.8, 1.9a and b, and 1.10. Reconstructions from Investigation 8.3.1.5.1 along with past surface water, and unsaturated- and saturated-zone characterizations will lead to an understanding of the Quaternary regional hydrologic regime. This information along with models of future climate conditions and estimates of future meteorological conditions from Investigation 8.3.1.2.1, and models of the unsaturated and saturated zones from the geohydrology program (Section 8.3.1.2) will help determine the effects of climate change on geohydrology. This will require the development of a relationship between climate and infiltration and recharge.

Technical rationale for the investigation

Climatic, igneous, tectonic, and erosional processes may potentially change the geohydrologic setting at Yucca Mountain. The purpose of this investigation is to determine the hydrologic conditions during the Quaternary that have differed significantly from present conditions due to changes in the climatic processes. This information will be used to evaluate the likelihood of recurrence over the next 100,000 yr of episodic conditions that may affect the regional flow system. Of specific interest are (1) the maximum altitude of the water table during pluvial periods of the Pleistocene Epoch, (2) the effects of water-table rises on shortening of ground-water flow paths to discharge areas, and (3) the magnitude of increases in recharge during pluvial periods. With this information, questions such as the following can be addressed: "What is the possibility of the repository flooding due to a rising water table during a return of pluvial conditions?" and "How large an infiltration flux might move through the repository in the future?" These potential future hydrologic conditions resulting from changing climatic conditions will be predicted through the use of numerical model sensitivity analyses. These sensitivity analyses (which are discussed in detail in each appropriate activity) will involve assessing the sensitivity of flow in the unsaturated and saturated zones to variations in infiltration and recharge.

The relationship between climate and infiltration and recharge will be developed on the basis of studies conducted under this testing program. Once this relationship is developed, the results of the sensitivity analyses will be used to identify the climatic parameters needed for assessing future conditions in the unsaturated and saturated zones. This information can then be used by the future climate modeling study (Section 8.3.1.5.1.6) to simulate the necessary scenarios that describe the conditions and occurrence of significant periods of climatic variation. Subsequently, the hydrologic models will use these predicted climatic conditions to simulate future infiltration to the unsaturated zone and recharge to the saturated zone.

Recurring pluvio-glacial climate conditions could shorten the time for radionuclide transport from the repository to the accessible environment if it is shown that percolation flux is increased through the repository block. The velocity increase produced by increased infiltration will be predicted by site-scale modeling. Also of significance is the maximum water-table rise that might accompany a recurring pluvio-glacial climatic condition, travel time be shortened by reducing the thickness of unsaturated zone below the repository (Czarnecki, 1985).

CONSULTATION DRAFT

The water-table altitude beneath the repository block reflects an interaction of many factors, including (1) the local recharge rate, (2) the lateral flux in the saturated zone resulting from recharge in upgradient areas, (3) vestiges from prior climatic regimes that persist because of storage effects, (4) distance to and altitude of regional discharge boundaries, and (5) especially, the distribution of conductivities and structures in the saturated zone. Computer models can functionally relate these conditions. A water-table change can be predicted due to a change of any one (or more) variable, if the model has been calibrated and checked against known conditions. Obtaining reliable predictions of water-table change will require knowledge of past changes of recharge distribution and discharge positions as well as sufficient detailed geometry and conductivities of units in the entire flow field. The studies of this investigation include (1) the interpretation of geomorphic and stratigraphic evidence of paleofloods; (2) the evaluation of analog recharge sites to estimate past, and, therefore, future, infiltration characteristics (ground-water recharge); (3) the search for hydrochemical evidence of waters that infiltrated in the past; and (4) the location of past points of ground-water discharge as evidenced by former springs, mineral vein fillings, and cave deposits recording higher water levels in the past. These studies have been formulated to provide the information required to predict the water-table fluctuations.

Paleoflooding will be investigated to improve the knowledge of severe surface runoffs during prehistoric times and to ascertain the relationships between those floods and paleoclimates. The investigation will examine alluvial deposits, debris-flow scars and deposits, severe erosion scars, and stone-stripe deposits to improve the understanding of the processes that formed them, and to determine whether these features have modern analogs that were formed or are forming under present climatic conditions. Results will provide a perspective on differences and similarities between past and present floods, and the relations to different climates. In addition, an improved understanding of the relation between paleoclimate and past floods will supplement predictions of future flooding based on rainfall-runoff modeling (Section 8.3.1.2.1.3).

The increased recharge that would occur under a return to pluvial conditions would depend upon a variety of interrelated factors. These factors include not only the amount of increase in average annual precipitation, but also the seasonal distribution and type of precipitation; the amount and rate of snowmelt; and changes in evapotranspiration, runoff characteristics, and soil and plant cover. Modern settings analogous to past climatic conditions at Yucca Mountain will be identified, instrumented, and studied to determine the infiltration versus precipitation relationships that relate to past and future climates. These modern settings, referred to as analog recharge sites, will be identified based on the rock-soil-vegetation cover, geology, topography, meteorological conditions, and hydrochemical properties of the precipitation, surface water, and soil moisture. Then, by evaluating the characteristics of each site, the conditions and rates of ground-water infiltration and recharge representative of past and future pluvial conditions will be estimated.

To gain a further understanding of the Quaternary ground-water conditions at Yucca Mountain, the discharge area of the ground-water basin will be

CONSULTATION DRAFT

studied for evidence of prior water-table elevation, discharge, and temperature. The potentiometric surface in the regional carbonate aquifer is gentle in slope due to the high transmissivity (Section 3.6). Provided that tectonic deformation can be ruled out, prior gradients obtained from paleospring elevations are related linearly to prior discharge. Slope extrapolation to the site and to recharge areas may provide estimates of prior potentiometric altitudes. A study of paleospring deposits and fossils contained in them will indicate altitudes of former discharge points and suggest paleo-discharge rates. These studies are justified on the same basis as are efforts to interpret the fossil record and the paleohydrology of recharge areas. Both boundary conditions need to be defined for any one time modeled. Redundant and confirmatory data, such as the detailed study of zeolites for evidence of fossil saturation levels, will help substantiate the hydrologic model predictions.

Remote sensing and field survey methods will be used to locate structural features presently or formerly controlling regional flow and discharge areas. Biologic and fossil evidence will be assessed for past discharge rates and climatic implications. Carbonate deposits will be sampled in caves, where they formed at various levels reflecting different water-table elevations. Carbon and oxygen isotope ratios in such minerals reflect the age and climate of the waters that formed them; thus, cyclic history may be recorded for regional interpretation of the basin hydrology. Past discharges will also be estimated in discharge areas from measured conductivities and computed gradients.

On the basis of current knowledge of hydrogeologic properties, fluxes, hydraulic heads, and estimated recharge rates, past water-table altitudes will be calculated. To further reduce uncertainty in these results, additional information about past water tables will be sought. Hydrochemistry will be used to produce a second line of evidence for paleosaturation altitudes. Hydrochemical analyses have the potential of identifying waters of an age and oxygen-18/oxygen-16 ratio consistent with infiltration during a past pluvial period, thereby providing information on flow velocities and paths. In principle, a sufficiently refined model can then predict future fluctuations in the water table altitude if adequate boundary conditions are provided for the various climatic regimes.

8.3.1.5.2.1 Study: Characterization of the Quaternary regional hydrology

The objective of this study is to characterize the distribution of surface water, the unsaturated zone infiltration and percolation rates, and the ground-water potentiometric levels during the Quaternary Period in the vicinity of Yucca Mountain.

Activities planned for the study are (1) an evaluation of regional paleofloods, (2) an analysis of unsaturated zone hydrochemistry, (3) an evaluation of past regional discharge areas, (4) an analog recharge study, and (5) an assessment of calcite-silica vein deposits.

CONSULTATION DRAFT

8.3.1.5.2.1.1 Activity: Regional paleoflood evaluation

Objectives

The objectives of this activity are to

1. Identify the locations and investigate the hydraulic characteristics of paleoflood events, and compare this evidence with the locations and characteristics of modern flooding and geomorphic processes. These findings and comparisons will improve knowledge of the relationships between climate and flooding.
2. Assess the character and severity of paleoflood and debris hazards to assess the potential of flood and debris hazards for the repository during the preclosure period.

Parameters

The parameters for this activity are

1. Magnitudes, frequencies, areal extent, and hydraulic characteristics of paleoflood flows.
2. Quantities and characteristics of debris movement during paleofloods.

Description

Two trenches have been dug in the north fork of Coyote Wash; one cross-channel trench and one T-shaped trench. These trenches have exposed deposits recording a complex sequence of debris-flow and flood-flow events that occurred during the late Quaternary Period. The trenches have been mapped and analyzed to determine the interpretable characteristics of the paleofloods. Additional trenching, mapping, and stratigraphic analyses of alluvial deposits in neighboring stream channels north and south of Coyote Wash and in the NTS vicinity will be performed to improve understanding of past flooding in the Yucca Mountain region.

Erosion scars, stone stripes, and other debris deposits will be evaluated with regard to the geomorphic processes responsible for their formation (Investigation 8.3.1.6.1). Areas and drainages of concern will be reconnoitered for erosion scars and hillslope deposits. The features that may be the products of past extreme surface-water runoffs will be examined and recorded. Attempts will be made to develop criteria for dating the features to increase the value of these data with regard to ages and frequencies of debris movement. The widespread presence of stone stripes on hillslopes at and around Yucca Mountain may be evidence of paleofloods and related landslope failures. The presence of these large deposits of cobbles and boulders over substantial areas of steeply sloping terrain poses the concern that they could become entrained in future landslope failures and become incorporated within fluvially transported debris. Improved knowledge of the age and genesis of these deposits should confirm or allay concerns regarding their potential for contributing to future debris hazards. Results will be used in analyses of flooding and debris hazards (Investigation 8.3.1.16.1).

CONSULTATION DRAFT

Attempts will be made to date alluvial surfaces and unconsolidated stream-channel deposits. Much of the unconsolidated debris underlying alluvial surfaces and comprising stream-channel deposits was deposited by surface runoff. A determination of the ages of these alluvial surfaces will provide valuable knowledge of past floods. Specifically, it will date the recency of severe flooding at the sites of the deposits, and collectively, these ages may suggest whether severe runoff events of the Yucca Mountain area might be episodic or relatively continuous during recent geologic time. Relative ages of the surfaces will be determined from geomorphic mapping, and absolute ages might be determined using the newly developed technique of rock-varnish dating. A field and photo reconnaissance of areas of concern should help dictate the techniques to be applied in dating the surfaces.

The evidence of paleoflooding will be compared with the magnitudes and frequencies of historical floods. The streamflow and runoff information collected as part of the activities called "surface-water runoff monitoring" and "transport of debris by severe runoff" will be compared to assess the frequencies and magnitudes of present-day flooding in and around the NTS. Available evidence and knowledge of paleofloods will be compared with knowledge developed on current flooding to determine whether present-day flooding is more or less frequent and larger or smaller than past flooding. Modern geomorphic channel and slope processes and their resultant sediment deposits will be compared with fluvial and slope deposits of the past to determine similarities and dissimilarities between modern and paleo processes.

Methods and technical procedures

The methods and technical procedures for Activity 8.3.1.5.2.1.1 are given in the following table.

Method	Technical procedure		
	Number	Title	Date
Trench, map, and analyze stream-channels deposits	TBD ^a	TBD	TBD
Stone stripes, erosion scars, and other debris deposits evaluation	TBD	TBD	TBD
Dating of alluvial surfaces and unconsolidated stream-channel deposits	TBD	TBD	TBD

CONSULTATION DRAFT

Method	Technical procedure		Date
	Number	Title	
Comparison of evidence of paleofloods with magnitude and frequency of historical floods	TBD	TBD	TBD

^aTBD = to be determined.

8.3.1.5.2.1.2 Activity: Quaternary unsaturated zone hydrochemical analysis

Objectives

The objectives of this activity are to

1. Determine the past and infiltration percolation history at Yucca Mountain by analyzing the isotopic and chemical characteristics of water from the unsaturated zone.
2. Understand the past unsaturated-zone hydrologic system by modeling vadose-water hydrochemistry to help predict the future hydrologic system.

Parameters

The parameters for this activity are the isotopic composition and chemistry of unsaturated zone water; travel times (chlorine-36, carbon-14, tritium), flow paths (oxygen-18/oxygen-16 ratios, deuterium/hydrogen ratios), and sources of past recharge in the unsaturated zone.

Description

The unsaturated-zone hydrology of Yucca Mountain during the Quaternary will be characterized in terms of residence times, flow paths, and sources of infiltration from the chemical and isotopic characteristics of present-day vadose water. Isotopic data of tritium, carbon-14, and chlorine-36 (Activity 8.3.1.2.2.4.2) will be used to determine infiltration and percolation rates, residence times or travel times of the water in the unsaturated zone, and serve as a check on flow paths, velocities, and travel times computed from hydraulic parameters. By analyzing the isotopic composition of water, it will be possible to estimate the climatic conditions of past recharge and flow paths and support the findings of the paleoclimate studies (Investigation 8.3.1.5.1).

The results of other investigations associated with paleohydrology and paleoclimate, from which past vadose-water movement may be inferred, will be used in conjunction with the hydraulic parameters and hydrochemical and

CONSULTATION DRAFT

isotopic data of surface and subsurface waters for the interpretations of the Yucca Mountain recharge history.

All pore-water samples, if enough water can be obtained, will be analyzed for (1) carbon-14, tritium, and chlorine-36 isotopic activity; (2) oxygen, hydrogen, and carbon isotope ratios; and (3) water chemistry. If perched water is encountered in boreholes or the exploratory shaft facility, water samples will also be collected for chemical and isotopic analysis. Carbon-14 and chlorine-36 activities will be determined by tandem-accelerator mass spectrometry. Tritium activity will be analyzed using low-level gas counters or liquid scintillation counters. Stable isotope ratios will be determined using isotope-ratio mass spectrometry. Water chemistry, cations and anions, will be analyzed using inductively coupled plasma and ion chromatography. These tests will be performed in conjunction with other hydrochemical tests conducted in Activity 8.3.1.2.2.4.2.

Methods and technical procedures

The methods and procedures for Activity 8.3.1.5.2.1.2 are given in the following table.

Method	Technical procedure		Date
	Number	Title	
	(NWM-USGS-)		
Collect and transport core samples	HP-12,R2	Method for collection, processing, and handling of drill cuttings from unsaturated zone boreholes at the well site, NTS	30 Mar 87
	HP-131	Method for handling and transporting samples of unsaturated core for hydrochemical analysis	TBD ^a
Extract water from core samples	HP-125	Method of extraction of pore water by tri-axial compression	TBD
	HP-110	Extraction of pore waters by centrifuge methods	TBD
	HP-126	Extraction of pore waters by vacuum distillation	TBD

CONSULTATION DRAFT

Method	Technical procedure		Date
	Number	Title	
Analyze water samples	TBD	Procedure for determining the presence of tracers in pore water samples	TBD
	TBD	Data archiving, shipping and handling procedure	TBD
	HP-08, RO	Methods for determination of inorganic substances in water	6 Aug 82
	HP-11, RO	Method for determination of radioactive substances in water	18 June 82
Analyze water samples (continued)	HP-127	Carbon-14 dating by tandem accelerator mass spectrometer	TBD
	TBD	Procedure for analysis of constituent stable isotopes of water	TBD
	TBD	Method for analyzing water sample for chlorine-36	TBD

^aTBD = to be determined.

8.3.1.5.2.1.3 Activity: Evaluation of past discharge areas

Objectives

The objectives of this activity are to

1. Determine the location, type, and extent of hydrogeologic units in the ground-water discharge areas of the Amargosa Desert and Death Valley.
2. Understand the past quantity and quality of water in the discharge areas of Franklin Lake, Amargosa Desert-River, and Peter's Playa and to determine the paleohydrologic significance of Peter's Playa and Franklin Lake as discharge areas.

CONSULTATION DRAFT

3. Determine the location and hydrogeologic characteristics of paleo-spring deposits in the discharge area.
4. Determine the location and amount of discharge by evapotranspiration that has occurred at past discharge sites.
5. Understand the past and present discharge areas of the regional hydrologic system in order to predict the future saturated zone hydrologic system at Yucca Mountain.
6. Determine past ground-water levels in carbonate caverns as evidence of past hydrologic conditions.

Parameters

The parameters for this activity are

1. Past rates of evapotranspiration
2. Hydrogeologic units (location, type, and extent) in discharge areas.
3. Location of past discharge areas.
4. Past discharge of springs and seeps.
5. Past potentiometric head.

Description

Remote sensing techniques will be used to identify lineaments, fracture zones, types of vegetative cover and types of surficial units so that their hydrologic implications can be determined. The types of remote sensing techniques being considered for use include (1) Landsat multispectral scanner (MSS) and thematic mapping (TM) spectral bands; (2) high- and low-altitude aerial photography (black and white, color, and color infrared); (3) low-altitude predawn thermal data taken before, during, and after storm events; and (4) side-looking airborne radar. Remote sensing will be done in conjunction with Investigation 8.3.1.8.2. A literature search will be conducted to gather information about previous studies using these remote sensing techniques, and appropriate data bases will be collected from national agencies and private contractors. If necessary, new surveys will be run to supplement the existing information.

Linear features such as lineaments and fracture zones, will be mapped to identify areas of interaquifer connection. Existing geologic, geophysical, geochemical, hydrologic, and seismic activity data will be used to supplement the remote sensing data. Evidence of paleotectonic activity such as a facies change, and thickening or thinning of sedimentary units, will be identified from geologic data. Evidence of crystalline-basement discontinuities (structural or lithologic) will be identified by analyzing the geophysical data. Hydrologic and geochemical data will be compared with the lineament map to determine where linear structural or stratigraphic features appear to affect ground-water flow.

The characteristics of the vegetative cover and surficial units will also be identified using remote sensing techniques and categorized into units of equal infiltration-discharge capacity. Reflective and thermal-spectral characteristics will be used to identify the types, spatial distribution, and

CONSULTATION DRAFT

density of the vegetation and surficial units. The soil moisture content will also be evaluated using reflective and thermal scanner data. Field inspections will be made to verify the remote sensing data. The correlation between the hydrologic and spectral properties of the surficial materials will be evaluated.

Past evapotranspiration (ET) rates will be estimated by calculations using modern ET rates determined in the study area (Study 8.3.1.2.1.2). Present ET rates are a function of climate and near-surface hydrologic conditions, such as soil type, vegetative cover, and depth to water. Calculation of past ET rates will require considerable input from paleoclimate studies (Investigation 8.3.1.5.1).

The infiltration-discharge characteristics of the surficial units and the areas of interaquifer connections will be incorporated into the three-dimensional hydrologic flow model of the regional ground-water-flow system (Activity 8.3.1.5.2.2.3).

Where possible, discharge from springs and seeps will be measured. Water-level measurements will be made in existing wells, caverns, and springs in addition to those collected under Investigations 8.3.1.2.1 and 8.3.1.2.3. Approximately five sites will be selected and recorders installed to provide a record of discharge.

Carbonate caverns located in the ground-water discharge areas south of Yucca Mountain provide a convenient window to the regional carbonate aquifer. The caverns will be mapped, sampled, and analyzed. Previous studies of deposits from these caverns suggest a possible 300,000-yr record of carbon and oxygen isotope variation (Winograd et al., 1985) that may provide information about the Quaternary geohydrologic and paleoclimatologic conditions at these sites and at Yucca Mountain. Deposits on the cavern walls provide a record of water-level changes in the regional carbonate aquifer dating back through the Quaternary. Biologic evidence from the cavern deposits also provides an association with ground-water chemistry.

Where possible, several available caverns will be entered, mapped, and sampled. Approximately 50 samples of the carbonate layers that are exposed on the cavern walls will be collected. The water in these caverns will also be sampled.

The samples will be analyzed to determine mineralogic and biologic composition and age. Information such as ostracode and diatom biology will be used to provide data about mode and environment of occurrence, including water chemistry. Up to 150 thin-sections of carbonate samples will be analyzed to determine mineralogic variations that provide evidence of varying ground-water conditions. Scanning electron microscope (SEM) and x-ray techniques will also be used on up to 100 of the thin-sections to determine the microscopic structure and composition of the banded carbonate units. Chemical, physical, and isotopic analyses will be run on up to 50 samples to determine the age of the water in the aquifer.

Shallow test holes will be rotary drilled or hand augered in the ground-water discharge area south of Yucca Mountain to obtain samples of the subsurface materials. Up to 50 rock-mineral and water samples will be analyzed to

CONSULTATION DRAFT

determine radiometric dates. The dating method used will depend on the sample type and amount of sample available. Thin sections will be made from the collected samples and analyzed to determine the mineralogic makeup of the materials. Samples will also be analyzed using x-ray, SEM, particle induced x-ray emission (PIXE), inductively coupled plasma (spectrometer) (ICP), and chemical analyses to provide additional mineralogic information that will be used to support the chemical, geologic, and hydrologic studies. The drill cuttings and core will be evaluated for biological indicators, such as ostracodes, diatoms, and opal phytoliths, using standard methods such as screening and washing of samples and microscope analysis of residue. Samples will be analyzed to determine the species and the environmental conditions under which the biologic indicator lived.

Studies of ostracode ecology along with studies of ostracode-valve chemistry will be conducted at selected sites to provide detailed information about the thermal and chemical properties of both discharging ground-water and also of the pools, ponds, and marshes supported by that water. This modern ecologic study conducted in conjunction with Study 8.3.1.5.1.2 will use about 30 ground-water discharge environments surrounding Yucca Mountain. The selection of sites will be based upon acquiring water upwelling from the regional aquifers, water from or near recharge sites in the mountains, and water derived from perched ground water in the valleys. Site selection will emphasize thermal and chemical diversity of modern discharging ground water as well as the aquatic environments supported by the discharging ground water. The selected sites will be sampled on at least a quarterly basis and a few key sites may be sampled more frequently. Sampling at each site will include multiple samples of each local subenvironment such as spring vents, spring pools, and marshes, as well as the ground water itself at some sites. The expected sample set will be approximately 400 samples. The study and calibration of the magnesium-calcium and strontium-calcium ratios in biogenic carbonate will be based on living material collected from a limited number of sites as well as on laboratory cultures of material from those sites.

The data derived from the previous collections will be organized in two ways: (1) a record of all environmental parameters (temperature, hydrochemical) associated with a species living at the time of collection and (2) the absolute and relative abundances of all adult ostracodes found in one or more quantitative sediment samples taken from each environment. Both sets of information will be evaluated statistically as well as qualitatively and will form the baseline information needed to properly interpret any taxa found in the fossil record. The ostracode-valve chemistry data will be used to establish magnesium/calcium and strontium/calcium partitioning coefficients for common species to determine the potential temperature and salinity resolution of this method. Ecological and chemical data from the ostracodes will be correlated with the modern ground-water hydrology to establish process relationships between all ostracode environmental data and known ground-water hydrology, thereby providing the basis for evaluating the nature of past discharge areas.

Results of this activity are expected to provide estimates of the past ground-water levels in the vicinity of Yucca Mountain during the Quaternary to be used in conjunction with past ground-water level data derived from evaluations at other regional discharge areas.

CONSULTATION DRAFT

Methods and technical procedures

The methods and technical procedures for Activity 8.3.1.5.2.1.3 are given in the following table.

Method	Technical procedure		
	Number	Title	Date
	(NWM-USGS-)		
Remote sensing analysis	TBD ^a	Remote sensing for lineaments, fracture zones, vegetative cover, and surficial units	TBD
Field verification of remote sensing	GP-01, RO	Geologic mapping	1 Mar 83
	TBD	Geohydrologic mapping	TBD
Spring/seep discharge measurement	HP-34, RO	Preliminary method for measuring discharge for an aquifer test using a staff gage and a calibrated container	15 May 85
	TBD	Continuous recording of spring discharge	TBD
Petrographic and biological analysis	TBD	TBD	TBD
Radiometric dating	TBD	TBD	TBD
X-ray, SEM, PIXE, ICP and chemical analysis	TBD	TBD	TBD
Field mapping and sampling	TBD	Underwater procedures	TBD
Petrographic, SEM, and X-ray analysis of carbonate samples	TBD	TBD	TBD
Water sampling and chemical analysis	HP-08, RO	Methods for determination of inorganic substances in water	6 Aug 82

CONSULTATION DRAFT

Method	Technical procedure		Date
	Number	Title	
Water sampling and chemical analysis (continued)	HP-11, R0	Methods for determination of radioactive substance in water	18 June 82
	HP-13, R0	Collection and field analysis of unsaturated zone groundwater samples	29 Aug 83
	HP-23, R0	Collection and field analysis of saturated zone groundwater samples	4 Nov 83
Drilling, coring and hand augering of wells and test holes	HP-37, R0	Preliminary procedure for drilling and coring of wet- and dry-lake sediments	14 Aug 84
	HP-83, R0 (in preparation)	Preliminary procedure for drilling and casing observation holes in sand deposits	TBD
Very high frequency (VHF) ground conductivity measurements	TBD	Use of VHF ground-conductivity measurements for mapping of water tables	TBD
Sample collection and measurements	HP-54, R0 (in preparation)	Water-flow measurements using weirs, flumes, and barrels	TBD
	HP-91, R0 (in preparation)	Collection and field analysis of surface-water samples	TBD
	TBD	Procedure for conducting well inventory	TBD
Water-level measurements	HP-01, R0	Methods for determining water levels	11 Jan 82

CONSULTATION DRAFT

Method	Technical procedure		
	Number	Title	Date
Water-level measurements (continued)	HP-25, RO (R1 in review)	Methods for measuring water levels using the Dodge Logging Van (I-127410)	20 July 84
	GP-02	Subsurface investigation	1 Mar 83
	HP-26, RO	Method for calibrating water-level measurement equipment using the reference steel tape	14 Aug 84
	HP-39, RO (in preparation)	Methods for determining water levels using the trailer-mounted hoist (I-134719)	TBD
	HP-71, RO (in preparation)	Methods for monitoring water-level changes using a Campbell Scientific 21X micrologger	TBD
	HP-75, RO (in preparation)	Method for measuring water levels in wells using reeled (2,600-ft and 2,800-ft) steel tapes	TBD
	HP-99, RO (in preparation)	Instructions for operation of a well sounder (M-scope) for measuring water levels	TBD
Data collection	HP-37, RO	Preliminary procedure for drilling and coring wet-and dry-lake sediments	14 Aug 84
	HP-23, R1	Collection and field analysis of saturated-zone ground-water samples	4 Nov 83

CONSULTATION DRAFT

Method	Technical procedure		Date
	Number	Title	
Data collection (continued)	HP-76, RO	Diatom enumeration studies	8 Apr 85
	HP-78, RO	Ostracode sample preparation and data acquisition procedures	8 Apr 85
Analysis of samples	HP-08, RO	Methods for determination of inorganic substances in water	6 Aug 82
	TBD	Procedure for analysis of constituent stable isotopes of water	TBD
	TBD	Radiometric dating of samples using carbon, uranium, and other isotopes	TBD
	TBD	Mineralogic, chemical, and isotopic analysis of geologic samples	TBD

^aTBD = to be determined.

8.3.1.5.2.1.4 Activity: Analog recharge studies

Objectives

The objective of this activity is to estimate the conditions and rates of ground-water recharge (infiltration) during the Quaternary in the vicinity of Yucca Mountain.

Parameters

The parameters for this activity are

1. Recharge rates of analog sites.
2. Infiltration rates of analog sites.
3. Effective moisture of analog sites.
4. Relationships between climate and infiltration and recharge.

CONSULTATION DRAFT

Description

Four or five localities will be evaluated to determine if they are suitable as late Pleistocene analog recharge sites. This evaluation will consist of characterizing the rock types, vegetation types and coverage, precipitation amounts, and topography. Sites will be selected that include a range of climatic conditions postulated to have existed on Yucca Mountain during the past pluvial climatic regimes of the late Pleistocene; data will be collected and used to determine paleorecharge rates.

At each selected site, the infiltration rate will be evaluated. Water samples will be collected from the vadose-water zone to determine the local infiltration quantity and chemistry. To estimate infiltration rates from the samples, hydrochemical technique that uses the mobile chloride ion as a tracer through the hydrologic cycle will be used (Claassen et al., 1986). The plant community and its relationship to recharge and soil moisture will be studied to estimate an infiltration rate for the whole basin. Remote sensing techniques will be used to determine type, spatial distribution, and density of vegetation. Soil temperatures also will be collected on a continuous basis. Evaluation of soil characteristics to determine their hydrologic properties and effect on consumptive water use will be evaluated if needed.

The temporal and spatial variability of chloride deposition will be calculated or measured at each of the selected sites. To accomplish this task, samples of precipitation, surface water, and moisture content of soils from the vadose water zone will be collected and analyzed. The integrated precipitation samples will be collected four times per year using a bulk sampler. Surface-water samples will also be collected from creeks and springs. Soil-moisture samples will be analyzed for ionic concentrations and for hydrogen and oxygen isotope ratios. A computer code will be developed to calculate the chloride chemistry in the recharge water.

Stream gaging measurements may be made at each of the selected sites and continuous-stage recording instruments installed where appropriate when necessary. Crest-stage gages will be used to back up the peak runoff measurements made by the continuous recorders. These stream measurements will be used to aid in the development of a local basin water budget.

Field investigations will be conducted to locate and collect contemporary pack rat middens from each selected site. The contemporary plant communities and pack rat collecting habits also will be investigated in the field and by field experiments in conjunction with Activity 8.3.1.5.1.3.1 (analysis of pack rat middens). Plant macrofossil assemblages will be collected in the field and sent to the laboratory for identification. These modern biological indicators will be interpreted and compared with similar macrofossil data that were collected in the vicinity of Yucca Mountain.

Methods and technical procedures

The methods and procedures for Activity 8.3.1.5.2.1.4 are given in the following table.

CONSULTATION DRAFT

Method	Technical procedure		
	Number	Title	Date
	(NWM-USGS-)		
Evaluation of potential study area	TBD ^a	Evaluation of potential study area	TBD
Meteorological measurements	TBD	Meteorological measurement	TBD
Water sampling and processing	HP-91, R0 (in preparation)	Collection and field analysis of surface-water samples	TBD
	HP-16, R1	Collection and preservation of atmospheric precipitation samples for isotope analysis	14 Aug 84
Surface water discharge measurement	TBD	Vadose sampling techniques	TBD
	TBD	Water-level measurement using a 21X datalogger and ten turn pot	TBD
	HP-54, R0 (in preparation)	Water-flow measurements using weirs, flumes, and barrels	TBD
	TBD	Intermittent surface water discharge measurement	TBD
Experimental leaching of tuffaceous rocks	TBD	Experimental leaching of tuffaceous rocks	TBD
Evaluation of contemporary pack rat middens	TBD	Evaluation of contemporary pack rat middens	TBD
Hydrologic budget modeling	TBD	Hydrologic budget modeling	TBD
		Mass balance modeling	TBD
Analysis of samples	HP-08, R0	Methods for determination of inorganic substances in water	6 Aug 82

CONSULTATION DRAFT

Method	Technical procedure		
	Number	Title	Date
Analysis of samples (continued)	TBD	Procedure for analysis of constituent stable isotopes of water	TBD
	TBD	Radiometric dating of samples using carbon, uranium, and other isotopes	TBD
	TBD	Mineralogic, chemical, and isotopic analysis of geologic samples	TBD
Soil properties and vegetative cover analysis	TBD	Soil hydrologic properties	TBD
Infiltration sampling and analysis	TBD	Vadose sampling techniques	TBD
	TBD	Chloride calculations	TBD

^aTBD = to be determined.

8.3.1.5.2.1.5 Activity: Studies of calcite and opaline silica vein deposits

Objectives

The objective of this activity is to determine the ages, distribution, origin, and paleohydrologic significance of calcite and opaline silica deposits along faults and fractures in the vicinity of Yucca Mountain.

Parameters

A list of possible parameters includes

1. Mineralogy--including minerals present, degree of crystallinity, and chemical composition.
2. Petrology--including textures and mineral paragenesis.
3. Morphology--including large scale structure and vertical and areal extent.

CONSULTATION DRAFT

4. Paleontology--including species present and absolute and relative abundances.
5. Chemistry--including major, minor, and trace element contents of bulk samples and mineral separates.
6. Hydrology--including modeling of possible flow paths.
7. Geochronology--including uranium-series, uranium-trend, potassium-argon dating method, and fission-track ages of fracture-filling and fracture-hosting materials.
8. Isotopic compositions of hydrogen, carbon, oxygen, strontium, and lead.

Description

Cryptocrystalline calcite, with and without opaline silica, fills many faults and fractures in the vicinity of Yucca Mountain. These fillings may have originated by one or more mechanisms including pedogenic, perched-water spring, deep-seated spring, hydrothermal spring, or hydrotectonic processes similar to those described by Kopf (1982). Each possible origin may have significant implications for the paleohydrology at repository depth, and thus, knowledge of the origin is important for predicting anticipated and unanticipated events that may act on the repository in the future.

Plans for this activity are flexible because results obtained by many different methods will need to be integrated. Additionally, results from one method may either obviate or necessitate tests by other methods. Finally, before initiating the investigations, a detailed plan will be subjected to critical review by an external peer panel and will be modified according to suggestions of the review committee.

The general approach will be to gather data through a multidiscipline approach that will include field investigations, mineralogy, geochemistry, fluid-inclusion studies, geochronology, tracer-isotope, stable-isotope studies, paleontology, and hydrology. Materials that will be studied include not only fault and fracture fillings found in trenches, natural exposures, and drill cores, but also possible analog deposits such as cold spring, hydrothermal spring, and pedogenic deposits. Some of the materials collected by this broad approach are expected to have applications to other activities. For example, some data and raw sample material will likely be applicable to seismotectonic activities, and thus close cooperation with these aspects of the program will be necessary.

Field investigations of the deposits will be accomplished through a combination of trenching and drilling. Veins exposed in trench walls will be mapped in detail. Samples will be collected such that any changes in character as a function of lateral extent or vertical extent will be represented. If trenching does not expose the maximum depth of at least one vein deposit, a series of shallow vertical holes may be drilled so as to intersect the fracture containing the vein deposit at successively greater depths. If a base for the deposit is not found by a depth of 20 m, an angle hole may be

CONSULTATION DRAFT

drilled to an approximate depth of 80 m to attempt to ascertain the depth limit of the deposit.

Standard mapping techniques will also be used to determine the location and areal distribution of calcite and opaline silica deposits in the vicinity of Yucca Mountain. This datum will constrain possible origins for the deposits and will be a critical point for modeling of the paleo and possible future hydrologic flow systems. If field mapping locates an unfaulted calcite and opaline silica deposit at a bedrock-colluvium contact, that deposit will be thoroughly investigated as a possible analog to the fracture filling exposed in Trench 14, a trench located near the proposed surface facility site.

Fracture-filling materials, wallrock of the fractures, and samples of possible analog materials will be subjected to mineralogic study by such techniques as petrographic microscopy, x-ray diffraction, scanning electron microscopy, and standard clay-mineral analysis. Precise knowledge of mineral assemblages, degree of crystallinity of diagnostic phases, and mineral paragenesis of the fracture-filling materials may provide constraints on the origin of the deposits. In addition, alteration and reaction textures (or lack thereof) in the wallrock of the fractures may further constrain theories of origin.

Geochemical investigations will be used in support of and in conjunction with mineralogic studies. Major, minor, and trace-element compositions of whole-rock samples and of samples from specific phases from fracture filling and analog materials may prove to be diagnostic for certain possible modes of origin. The final choice of analytical methods will depend on sample sizes available, necessary precision, and detection limits. Anticipated methods include x-ray fluorescence, instrumental neutron activation analysis, and electron microprobe analysis. If any of the geochemical data reveal information of possible economic interest, samples will be referred to those investigating this aspect of the site (Section 8.3.1.9, human interference program).

Fluid inclusions (trapped samples of the liquids from which crystals grew) are common in carbonate and silicate minerals that crystallized in a variety of environments. Such inclusions, if present, will be analyzed in the fracture-filling materials as well as in samples from possible analogs. If fluid inclusions are of more than one phase, they will be heated to the homogenization temperature that represents a minimum estimate of the temperature of deposition.

Ages of fracture-filling materials will be determined by a number of different methods. These ages will be important in the understanding of sequential changes in the paleohydrology and in the determination of chronology for paleotectonics. The data will then be used to predict future hydrology and tectonics. Uraniferous calcite and opaline silica that behaved as closed systems can best be dated by uranium-series techniques. Uranium-series dating techniques on calcite and opaline silica may further constrain the age of these deposits if the uranium in these minerals behaves as a closed system. If suitable samples of volcanic ash can be obtained from within the fracture zones, potassium-argon dating will be attempted. Fission-track dating of apatite crystals separated from the wallrocks of the

CONSULTATION DRAFT

fractures will be attempted to see if temperatures were high enough to reset or lower apparent ages of the volcanic rocks.

The isotopic compositions of strontium and lead in the calcite-silica deposits and in samples from possible analog materials will be determined to see if these data can provide constraints on the origin of the calcite and opaline silica deposits. These isotopic compositions should be dependent on the isotopic compositions of the rocks through which the depositing fluid flowed and thus if the fluids passed through isotopically distinct units like those known to exist below Yucca Mountain, the data may identify paleohydrologic flow paths.

The isotopic compositions of oxygen, carbon, and hydrogen in the fracture-filling materials depend on temperature of deposition and isotopic compositions in the depositing fluid. If fluid inclusions can be found and analyzed, a unique temperature of deposition can be determined. Alternatively, the isotopic compositions of phases that crystallize in equilibrium with one another can be used to estimate the composition of the depositing fluid and the temperature of deposition. If the fact that equilibrium existed cannot be established, comparison of the data with data from possible analogs will at least constrain possible modes of origin.

Virtually all surface and many subsurface waters contain aquatic organisms and some of these become preserved as fossils in chemically precipitated deposits. The organisms present in a given body of water are determined by a large number of factors including temperature and chemical composition of the water. If organisms such as ostracodes are preserved within the fracture-filling material, their species and the trace-element composition of their calcareous remains can be compared with hydrologic and biologic data for present-day analogs to tightly constrain possible modes of origin.

The final phase of this activity will be to test possible modes of origin for consistency with hydrologic flow models (Section 8.3.1.2.1).

Methods and technical procedures

The methods and procedures for Activity 8.3.1.5.2.1.5 are given in the following table.

Method	Number	Technical procedure	
		Title	Date
Field work	UTP-01, RO	Hydrologic investigations	TBD ^a
	UTP-03, RO	Geologic investigations	TBD
	UTP-05, RO	Geochronologic investigations	TBD

CONSULTATION DRAFT

Method	Technical procedure		
	Number	Title	Date
	UTP-10, RO	Fenix & Scisson drill site unit task procedure	TBD
	GP-01, RO	Geologic mapping	1 Mar 83
	GP-05, RO	Geologic support activities	1 Mar 83
	GP-07, RO	Geologic trenching studies	14 Aug 84
	MDP-01, RO	Identification, handling, storage, and disposition of drillhole core and samples	
Isotope geology	GCP-02, R1	Labeling, identification, and control of samples for geochemistry and isotope geology	30 Apr 81
	GCP-03, RO	Uranium-series dating	15 June 81
	GCP-04, RO	Uranium-trend dating	15 June 81
	GCP-06, RO	Potassium-argon dating	15 June 81
	GCP-07, RO	Geochemical mineral separations	15 June 81
	GCP-08, RO	Fission-track dating	15 June 81
	GCP-09, RO	Spike calibrations	15 June 81
	TBD	Chemical separations of rubidium and strontium	TBD
	TBD	Mass-spectrometry of strontium	TBD
	TBD	Chemical separations of uranium, thorium, and lead	TBD
	TBD	Mass-spectrometry of lead	TBD
	TBD	Separation of oxygen and carbon from carbonate	TBD
	TBD	Separation of oxygen from silicate	TBD
	TBD	Separation of hydrogen from silicate	TBD
Isotope geology	TBD	Liberation and collection of fluid inclusions	TBD
	TBD	Mass-spectrometry for hydrogen	TBD

CONSULTATION DRAFT

Method	Technical procedure		Date
	Number	Title	
	TBD	Mass-spectrometry for carbon	TBD
	TBD	Mass-spectrometry for oxygen	TBD
	TBD	Alpha-spectrometry	TBD
Hydrologic studies	HP-08, R0	Methods for determination of inorganic substances in water	6 Aug 82
	HP-11, R0	Methods for determination of radioactive substances in water	18 June 82
	HP-23, R1	Collection and field analysis of saturated-zone ground-water samples	4 Nov 83
	HP-37, R0	Preliminary procedure for drilling and coring of wet- and dry-lake sediments	14 Aug 84
Biological studies	HP-76, R0	Diatom enumeration studies	8 Apr 84
	HP-78, R0	Ostracode sample preparation and data acquisition procedures	8 Apr 84
Mineralogical and chemical studies	QP-04, R2	Handling, storage, and shipping of samples	TBD
	QP-14, R0	One-time research and development work	TBD
	DP-04, R3	Thin-section preparation	TBD
	DP-06, R2	Carbon coating of samples with DV-502 vacuum evaporator	TBD
	DP-07, R1	Microprobe operating procedure	TBD
	DP-16, R1	Siemens x-ray diffractometer procedure	TBD
	DP-19, R1	Sample preparation: rock powders	TBD
Mineralogical and chemical studies	DP-20, R1	Preparation of fused-glass beads from rock powder	TBD
	DP-24, R0	Alignment of Siemens diffractometer	TBD

CONSULTATION DRAFT

Method	Technical procedure		Date
	Number	Title	
	DP-25, R1	Clay mineral separation and preparation for x-ray diffraction	TBD
	DP-50, RO	Sputter coating with gold	TBD
	DP-51, RO	Mettler H80 sample weighing procedure	TBD
	DP-52, RO	Making fused discs with junior orbit shaker	TBD
	DP-53, RO	Pulverizing with Spex 8500 shatterbox	TBD
	DP-54, RO	Crushing with 50-ton hydraulic press	TBD
	DP-55, RO	Rock-splitting with 50-ton hydraulic press	TBD
	DP-56, RO	Brinkman automated grinding procedure	TBD
	TBD	Fluid inclusion homogenization	TBD
	TBD	Instrumental neutron activation	TBD
	TBD	X-ray fluorescence procedures	TBD

²TBD = to be determined.

8.3.1.5.2.2 Study: Characterization of the future regional hydrology due to climate changes

The objective of this study is to characterize the impacts of potential future climate changes on the regional and site surface-water system, the site unsaturated-zone hydrology, and the regional and site saturated-zone hydrology.

8.3.1.5.2.2.1 Activity: Analysis of future surface hydrology due to climate changes

Objectives

The objectives for this activity are to

1. Simulate past changes in runoff and surface-water storage (lakes) resulting from past climatic change.

CONSULTATION DRAFT

- 2. Use the relationship between paleoclimate and paleo surface-water conditions to predict the impact of future climatic conditions on surface-water hydrology at the site.

Parameters

The parameters for this activity are past and future runoff and surface-water storage.

Description

Precipitation-runoff relations of modern surface-water conditions and basin characteristics will serve as the basis for the development of a present-day precipitation-runoff model (or models) for the Yucca Mountain site. Sufficient data will be collected through the current precipitation and streamflow gaging programs (Activity 8.3.1.2.1.2.1 and Section 8.3.1.12) and rainfall-runoff modeling in Fortymile Wash basin (Activity 8.3.1.2.1.3.3) to allow modeling of modern-day, precipitation-runoff relationships. The model will be run to simulate estimated paleoconditions derived from other activities such as precipitation, snowpack conditions, soil evaporation, interception of precipitation by vegetation, and transpiration. These model runs will be used to validate the model against inferred conditions derived from past proxy records. The model will be used to simulate future runoff conditions resulting from hypothesized climatic change based on results of the paleorunoff simulations.

Methods and technical procedures

The methods and procedures for Activity 8.3.1.5.2.2.1 are given in the following table.

Method	Technical procedure		Date
	Number	Title	
Precipitation-runoff modeling of past and future surface-water conditions	TBD ^a	Precipitation-runoff model	TBD

^aTBD = to be determined.

8.3.1.5.2.2.2 Activity: Analysis of future unsaturated zone hydrology due to climate changes

Objectives

The objective of this activity is to predict quantitatively the potential effects of future climatic conditions on infiltration, percolation, and the degree of saturation of the unsaturated zone at Yucca Mountain.

CONSULTATION DRAFT

Parameters

The parameters for this activity are

1. Relationship between climate and infiltration.
2. Time-dependent spatial distributions of moisture potential, pore-gas pressure, saturation, and moisture flux.

Description

The unsaturated-zone hydrologic model, to be developed in Activity 8.3.1.2.2.9.2, will provide a calibrated model of present-day flow conditions and processes. The model will be calibrated using initial and boundary conditions, and geohydrologic material properties. The results of artificial infiltration studies will be incorporated into the model development (Activity 8.3.1.2.2.1.3). Sensitivity studies will be performed on a sequence of transient simulations over the next 10,000 yr during which the rate of net land-surface infiltration will be varied over time and space. These mathematical simulations will investigate the effects of scenarios chosen to represent infiltration rates resulting from probable climatic changes extrapolated from paleoclimatologic and paleohydrologic conditions. The set of simulations will delimit the sensitivity of the moisture-potential, saturation, perched-water, and moisture-flux distributions within the natural, unsaturated-zone flow system to changes in infiltration arising from climatic variations.

Methods and technical procedures

The methods and procedures for Activity 8.3.1.5.2.2.2 are given in the following table.

Method	Technical procedure		Date
	Number	Title	
Unsaturated-zone hydro- logy model sensitivity analysis (due to climate changes)	TBD ^a	TBD	TBD

^aTBD = to be determined.

CONSULTATION DRAFT

8.3.1.5.2.2.3 Activity: Synthesis of effects of possible future recharge due to climate changes on hydrologic characteristics of the Yucca Mountain saturated zone

Objectives

The objectives of this activity are to

1. Reconstruct paleohydrologic conditions at Yucca Mountain and use these conditions together with the paleoclimatic conditions reconstructed under Investigation 8.3.1.5.1 as a basis to predict the impact of future climatic conditions on the saturated-zone hydrologic system.
2. Synthesize the existing paleohydrologic data through the use of numerical simulation techniques to determine the effects that greater recharge would have on water-table altitude, ground-water flow paths, and hydraulic gradients between Yucca Mountain and the accessible environment.

Parameters

The parameters for this activity are

1. Relationship between climate and recharge.
2. Distribution of potentiometric head (past, present, and future).

Description

Records of past climates for the Yucca Mountain area indicate that conditions wetter and cooler than modern day have occurred in the past (Section 5.2.1). These conditions may have led to higher water levels in the past (Winograd and Szabo, 1986). Correlations between past climatologic and geohydrologic conditions, including past recharge rates, will be inferred using paleo-water levels determined from the study of past discharge areas and analog recharge sites. Past climate changes will be correlated with geologic and biologic evidence of paleohydrologic conditions (Activities 8.3.1.5.1.2.1 and 8.3.1.5.1.3.1).

A three-dimensional numerical ground-water flow model of the regional flow system (developed under Activity 8.3.1.2.1.4.4.) will be calibrated using modern-day conditions. The higher water levels inferred for the past will be simulated to estimate the magnitude of past recharge.

The simulation of wetter conditions will be used to assess potential changes in water-table altitude, ground-water flow rates, and ground-water flow directions. Recharge will be varied from modern conditions up to the maximum probable amount to be expected in the next 10,000 yr. Sensitivity analyses will be done to determine the appropriate time periods needed for model input.

Results of previous modeling (Study 8.3.1.2.1.4) will be the basis for future work. Recharge boundary fluxes applied to both two- and three-dimensional models for regional ground-water saturated flow (Czarnecki, 1985;

CONSULTATION DRAFT

Sinton and Downey, 1986) were based on the best estimates of recharge believed to occur either as throughflow into the area or as areally distributed recharge. Principal areas where significant areally distributed recharge may occur are Pahute Mesa, Rainier Mesa, Timber Mountain, and Fortymile Wash.

New data on climatic conditions and recharge mechanisms under various scenarios (monsoon versus thunderstorm versus snowfall precipitation and corresponding vegetation changes) will be incorporated into the simulation of increased-recharge conditions.

Methods and technical procedures

The methods and procedures for Activity 8.3.1.5.2.2.3 are given in the following table.

Method	Technical procedure		Date
	Number	Title	
Documentation of calibrated regional ground-water flow model	TBD ^a	TBD	TBD
Simulation of future ground-water conditions due to climatic change	TBD	TBD	TBD

^aTBD = to be determined.

8.3.1.5.2.3 Application of results

The information derived from the studies and activities of the plans described previously will be used in the following areas of site characterization, repository design, and performance assessment:

<u>Information need, issue or investigation</u>	<u>Subject</u>
1.1.3	Calculational models for release scenario classes (Section 8.3.5.13.3).
1.8	NRC siting criteria (Section 8.3.5.17)
1.9a	Higher level findings (Section 8.3.5.18)
8.3.1.2.1	Regional hydrologic system.
8.3.1.5.1	Nature and rates of climate change.

CONSULTATION DRAFT

8.3.1.5.2.4 Schedules and milestones

Investigation 8.3.1.5.2 contains two studies: 8.3.1.5.2.1 (characterization of the Quaternary regional hydrology) and 8.3.1.5.2.2 (characterization of the future regional hydrology due to climatic changes). In the figure that follows, the schedule information for these studies is presented in the form of timelines. The timelines extend from implementation of the approved study plans to the issuance of the final products associated with the studies. Summary schedule and milestone information for this investigation can be found in Section 8.5.1.1.

The first study on Quaternary regional hydrology (8.3.1.5.2.1) is ongoing, while the second study on future regional hydrology (8.3.1.5.2.2) is expected to start in the second year of site characterization.

The synthesis and modeling performed in this investigation will proceed in parallel with activities in the geohydrology program and with performance and design activities and will interact with them in an iterative fashion. The impact of future climatic changes on the future regional hydrology system is needed to support the resolution of Issues 1.1 (total system performance, 1.8 (NRC siting criteria, and 1.9 (higher level findings--postclosure. This investigation will also provide data on future changes to the hydrologic system to the seal characteristics (Issue 1.12), waste package characteristics (Issue 1.10), the geohydrology program (Section 8.3.1.2), the geochemistry program (8.3.1.3), and the erosion program (8.3.1.6).

The study numbers and titles corresponding to the timelines are shown on the left of the following figure. Points shown on the timelines represent major events or important milestones associated with this study. Solid lines represent study durations, and dashed lines represent interfaces. The data input and output at the interfaces are shown by circles. The ticks on the time scale represent one-year increments.

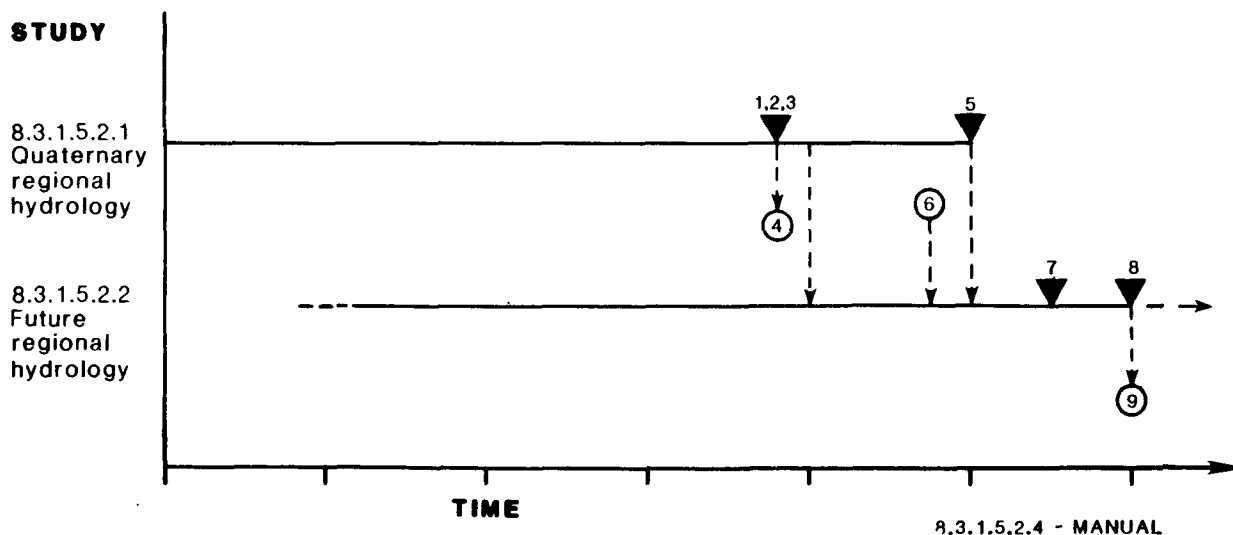

CONSULTATION DRAFT

The points on the timeline and the data input and output at the interfaces are described in the following table:

<u>Point number</u>	<u>Description</u>
1	Milestone P690. Report available on paleodischarge areas.
2	Milestone Z280. Report available on Quaternary recharge areas.
3	Milestone Z281. Report available on hydrogenic deposits.
4	Conceptual model of calcite silica deposits available for consideration in scenario screening in Issue 1.1 (total system performance, Section 8.3.5.13) and for postclosure tectonics.
5	Milestone Q041. Report available on the characterization of Quaternary regional hydrology.
6	Final input from 8.3.1.5.1.6 (characterization of future climates and environments) available for Study 8.3.1.5.2.2).
7	Milestone Z283. Report available on future changes in unsaturated zone hydrology due to climatic change. Milestone P745. Report available on effects of future climate change on saturated zone hydrologic system.
8	Milestone Q162. Report available on potential effects of future climate conditions on hydrologic characteristics at Yucca Mountain.
9	Input to Issue 1.1 (total system performance) on effects of future climatic change on the hydrologic system.

***Nuclear Waste Policy Act
(Section 113)***

Section 8.3.1.6

Consultation Draft

EROSION

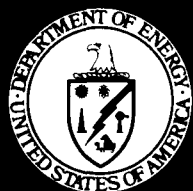

Site Characterization Plan

***Yucca Mountain Site, Nevada Research
and Development Area, Nevada***

Volume V

January 1988

***U.S. Department of Energy
Office of Civilian Radioactive Waste Management
Washington, DC 20585***

CONSULTATION DRAFT

8.3.1.6 Overview of the erosion program: Description of the future erosional rates required by the performance and design issue

Summary of performance and design requirements for erosion information

The following summarizes the requirements for erosion data from the design and performance issues:

1. The surface characteristics program (8.3.1.14), requires information on the expected magnitude and locations of erosion, both on bedrock and alluvial-colluvial surfaces.
2. Issue 1.12 (Section 8.3.3.2, seal characteristics), requires information on the erosion potential (rates) near shafts to support the design of seals.
3. The human interference program (8.3.1.9) requires information on erosion to determine the most suitable locations for the surface markers and monuments of the warning system.

Existing regional data indicate that erosion will not affect the minimum burial depth (200 m) required by 10 CFR 960.4-2-5(b). Using the maximum erosion rates presented in Section 1.1 of 40 cm/1,000 yr, the amount of erosion that will occur over the next 10,000 yr (4 m), or even 100,000 yr (40 m), is much less than the total burial depth. Therefore, even an increase in erosion rates by a factor of two or three would have no impact on burial depth relative to the 200 m disqualifying condition.

Large-scale mass wasting (e.g., rock slides and debris flows) does not appear to pose a significant hazard to waste isolation at Yucca Mountain. Eolian processes and plans to investigate them within the climate program, are discussed in Section 8.3.1.5.1.4.4. The erosion test program concentrates on fluvial and hillslope erosion.

Approach to satisfy performance and design requirements

The general strategy used in developing the postclosure erosion program is to identify the site-specific geomorphic parameters and data that are needed to satisfy the design and performance issues and to ensure that the 200 m disqualifying condition is not exceeded. As discussed in Chapters 1, 3, and 5, the desert environment of the southern Great Basin is one of the factors that has made Yucca Mountain potentially advantageous for the long-term disposal of high-level radioactive waste. From the standpoint of waste containment, the comparative aridity of the climate and the relatively low rates of tectonic uplift (relative stability of the tectonic setting) during the Quaternary period have kept the long-term erosion rates low. The future persistence of tectonic stability coupled with the semiarid-to-arid climatic conditions would result in continued low erosion rates through the post-closure period, and assist in the isolation of the waste. Thus, erosional processes are not believed to pose a hazard to waste isolation at Yucca Mountain.

CONSULTATION DRAFT

For the integrity of the repository to be at risk from erosional breaching, a combination of highly unlikely topographic, climatic, and tectonic conditions would be required. Climatic change in the postclosure period to relatively wetter semiarid conditions would result in a sustained period of higher precipitation and runoff, possibly increasing the average upland erosion rate above the present level. Although data presented in Chapter 1 indicate that Quaternary erosion rates during wetter climates were not substantially greater than present-day rates, an increase of precipitation and runoff could result in slightly higher erosion rates at Yucca Mountain. The erosion rates could also be aggravated by a period of sustained tectonic uplift, if uplift rates were to greatly exceed those estimated for the Quaternary period. It must be emphasized, however, that the probability of this hypothetical scenario occurring is extremely low. The relative vertical tectonic adjustment has been less than 3 cm/1,000 yr during the late Cenozoic (Miocene to present), and the average maximum downwasting rate was estimated to be 2 cm/1,000 yr (Section 1.1). It is highly unlikely that climatic or tectonic changes during the postclosure period will significantly change the rate of downwasting. Additionally, increased erosion of hillslope and uplands would result in increased aggradation on piedmonts and lowlands which would counterbalance local erosion rates.

Because erosion is not expected to pose a hazard to the isolation of waste at Yucca Mountain (Issue 1.1 Section 8.3.5.13), very few performance and design issues request information from the erosion program. Only Issue 1.12 (Section 8.3.3.2, seal characteristics), the surface characteristics program (Section 8.3.1.14), and the human interference program (Section 8.3.1.9), require input from the erosion program. Table 8.3.1.6-1 lists the parameters requested by these issues and programs.

Issue 1.12 (seal characteristics, Section 8.3.3), requests information on the erosion potential near specified shafts. This information will be provided through Investigation 8.3.1.6.1, which will determine the current rates of erosion at the site and through Investigations 8.3.1.6.2 and 8.3.1.6.3, which will determine the potential effects of future tectonic and climate activity on erosion at the site. The surface characteristics program (8.3.1.14) requires information on the present locations and rates of erosion. This information will be provided by Investigation 8.3.1.6.1.

The human interference program (8.3.1.9) requires information on erosion that will support the determination of the reliability and survivability of surface markers and monuments. Although erosional processes are not expected to pose a hazard to waste containment and isolation, the effects of rapid stream incision needs further study because of its potential consequences to surface markers and monuments. Markers need to be placed in areas of low erosion or deposition to aid survivability. The data obtained from studies of stream incision will be used in the design of the warning system, and will augment those studies being undertaken in support of the surface characteristics program (Section 8.3.1.14). Investigations 8.3.1.6.2 and 8.3.1.6.3 will provide information on the potential effects of future tectonic and climate activity on erosion at the site. This information will also be used to locate surface markers and monuments in areas with potential for low future erosion to enhance survivability.

Table 8.3.1.6-1. Parameters provided by the erosion program that support performance and design issues

Issue requesting parameter	SCP section number	Performance or design parameter	Tentative Goal	Desired confidence	Characterisation parameter	Testing basis			Study number
						Current estimate of parameter range	Current confidence	Needed confidence	
1 12 (seal characteristics)	8 3 3 2	Erosion potential at exploratory shafts 1 and 2, men and materials shaft, and emplacement area exhaust shaft	< 1 m of preferential erosion of bedrock at shaft entry locations over 1,000 yr	Low	Long term erosion rates at shaft entry locations	40 cm/1,000 yr	Very low	Low	Study 8 3 1 6 1 1 Study 8 3 1 16 1 1
1 1 (total system performance through human interference program)	8 3 5 13, 8 3 1 9	Locations of low erosion or deposition for surface markers	Identify geomorphologically stable areas along controlled-zone boundary	Low	Long term rates of erosion, deposition at proposed marker locations	40 cm/1,000 yr	Very low	Low	Study 8 3 1 6 1 1 Study 8 3 1 16 1 1
4 4 (technical feasibility through surface characteristics program)	8 3 2 5, 8 3 1 14	Scour potential along Forty-mile Wash at bridge locations, erosion potential along proposed roads	< 13 m of scour at bridge foundations over 100 yr, < 5 m of bed erosion in channel over 100 yr, < 1 m sheet erosion on roadways over 100 yr	Low	Rates of soil, bedrock erosion at bridge locations over 100 yr, erosion along roads and channel beds	40 cm/1,000 yr	Very low	Low	Study 8 3 1 6 1 1 Study 8 3 1 16 1 1

8.3.1.6-3

CONSULTATION DRAFT

CONSULTATION DRAFT

The relationship between the investigations performed under this characterization program and the issues and programs that require information on erosion locations, rates, and processes is shown in Figure 8.3.1.6-1.

Interrelationships of erosion investigations

Four investigations have been developed to provide the data required by the performance and design issues. Many of the necessary parameters have been obtained and evaluated as part of the ongoing scientific studies at the Nevada Test Site (NTS) in support of the weapons testing program. In most instances, data are not site specific and, therefore, not adequate to satisfy the performance and design issues. Studies will be carried out during site characterization to satisfy these remaining data needs.

Investigation 8.3.1.6.1 will collect site-specific data on Quaternary erosion and stream incision rates, which will be used to calculate average erosion rates on Yucca Mountain and to develop a history of the downcutting episode(s) of Fortymile Wash. Investigation 8.3.1.6.2 includes studies to assess the potential effects of future climatic changes on locations and rates of erosion. Previously established regional erosion rates suggest that future changes in the climatic regime will not significantly affect upland and hillslope erosion rates. Local erosion data on Yucca Mountain and an evaluation of the relationship of increased runoff in Fortymile Canyon, Fortymile Wash, and their tributaries to localized stream incision rates are needed for Information Need 2.7.1 (Section 8.3.2.3.1). Investigation 8.3.1.6.3 will evaluate the effects of tectonic activity on rates of erosion.

Investigation 8.3.1.6.4 addresses the potential effects of erosion on the baseline hydrologic, geochemical, and rock characteristics at Yucca Mountain. Because the effects of erosional processes on the baseline conditions are not expected to pose any hazard to waste isolation and are not expected to affect the postclosure ground-water travel time, no further studies or activities are planned. These topics will be addressed in a topical report, which will present the discussion supporting termination of the erosion program.

Other investigations will provide data in the form of input parameters to the erosion program. Investigations 8.3.1.5.1 and 8.3.1.8.2 will provide data on the nature and extent of future climatic changes and tectonic activity, respectively. Data obtained to date on regional tectonic and climatic activity during the Quaternary Period suggest that very little change will occur in the erosional regime at Yucca Mountain during the postclosure period as a result of these processes (Chapters 1 and 5). Limited site-specific studies will be completed to determine quantitatively, on the basis of Quaternary erosion rates, the extent of potential stream incision that could result from future tectonic activity and climatic changes.

Although the long-term average upland and hillslope erosion rates have been established for the southern Great Basin, they may not be representative of actual erosion rates on Yucca Mountain or of the short-term episodes of stream incision that may occur when a critical process threshold is exceeded. Fortymile Canyon, Fortymile Wash, and their tributary channels, that are located on the eastern flanks of Yucca Mountain, may be subject to critical

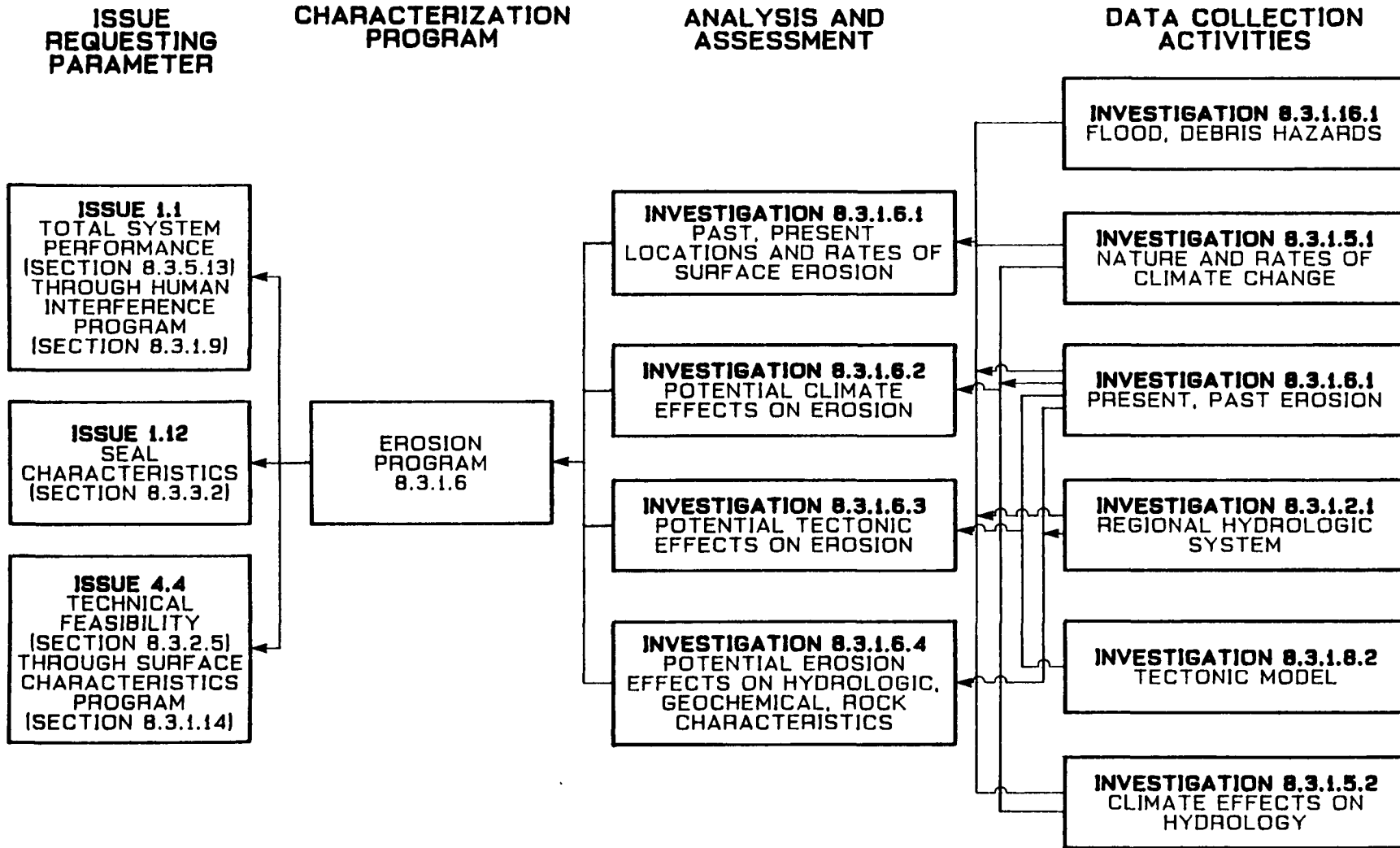

Figure 8.3.1.6-1. Relationship between erosion program and investigations.

CONSULTATION DRAFT

threshold (complex) response (the reaction of a fluvial system to a disruption of the equilibrium of the system). As discussed in Chapter 1, Section 1.1.3.2, very little site-specific information is presently available that would allow for the quantification of erosional processes at Yucca Mountain. Those data needs will be satisfied during site characterization.

The schedule information provided for investigations in this section includes the sequencing, interrelationships, and relative durations of the studies in the investigation. Specific durations and start/finish dates for the studies are being developed as part of ongoing planning efforts and will be provided in the SCP at the time of issuance and revised as appropriate in subsequent semiannual progress reports.

8.3.1.6.1 Investigation: Studies to determine present locations and rates of surface erosion

Technical basis for obtaining the information

Link to the technical data chapters and applicable support documents

Sections 1.1 (geomorphology), 3.2.1 (flood history and potential for future flooding), and 5.1 (modern climate and meteorology) summarize existing data relevant to this investigation. As discussed in these sections, site-specific data are not available for rates and locations of erosion, especially along Fortymile Canyon, Fortymile Wash, and their tributaries.

Parameters

Three groups of parameters will be measured or calculated as a result of the site studies planned for this investigation:

1. A geomorphic map of Yucca Mountain that defines areas of active erosion and areas of no erosion (i.e., geomorphic stability).
2. Rates, locations, and causes of incision in Fortymile Wash and its tributaries.
3. Average rates of hillslope erosion on Yucca Mountain.

Other site studies will provide data to support the determination of these parameters. Activities in support of Investigation 8.3.1.2.1 will supply data on the regional meteorology and surface water system. Investigation 8.3.1.5.1 will provide geomorphic information on surficial deposits and geomorphic interpretation of Quaternary history. Investigation 8.3.1.5.2 will provide paleoflood evaluations. Site flood and debris hazard data will be provided from Investigation 8.3.1.16.1.

Purpose and objectives of the investigation

The objectives of this investigation are to obtain the site-specific data needed to calculate average Quaternary hillslope erosion rates and accurate average short-term erosion rates associated with episodic erosion. This investigation will perform three activities and use information from the

CONSULTATION DRAFT

climate (Section 8.3.1.5) and geohydrology (Section 8.3.1.2) programs to support these objectives. Figure 8.3.1.6-2 shows how these data-collection sections will support the determination of present rates and locations of surface erosion. Three kinds of data will be obtained to characterize past distribution of hillslope and alluvial deposits, and surfaces of different ages will be shown on a geomorphic map of Yucca Mountain. First, the map will show the extent to which modern erosion has affected an essentially Pleistocene landscape. Second, local stream incision rates will be calculated by dating incised stream terraces and sand ramps by uranium-trend, uranium-series, radiocarbon, and cation ratio (rock varnish) dating methods. Third, average erosion rates on hillslopes will be calculated from dated hillslope surfaces by the rock varnish dating method.

Desert geomorphic processes acting in conjunction with extensional tectonism have molded the present topography of the Yucca Mountain area, and these processes continue very slowly to modify the landscape. The predominantly semiarid-to-arid climates of the past and present have helped to preserve the landscape of the region surrounding Yucca Mountain. Weathering in arid environments proceeds more slowly than in more humid environments, and materials on most of the bedrock slopes of the mountain appear to be only slightly weathered. Available data suggest that the region surrounding Yucca Mountain has been geomorphically stable during much of the middle and late Quaternary, and that rates of geomorphic processes are likely to remain generally low during the next 10,000 yr.

The locations of modern erosion are best shown on aerial photographs and large-scale topographic maps of Yucca Mountain where the drainage networks are clearly defined. Erosion on hillslopes is visible on aerial photographs because the recently stripped slopes are much lighter in color than adjacent deposits, which are coated with dark desert varnish. The amount and distribution of modern erosion is of very limited extent when compared with the vast areas of stable Pleistocene deposits in the Yucca Mountain area. The contrast between limited areas of modern upland and hillslope erosion versus large stable areas is a strong argument for low erosion rates at the proposed repository site.

Average late Tertiary and Quaternary erosion rates for local areas of the southern Great Basin and northern Mojave Desert have been inferred from height differences between active and relict basalt-capped erosion surfaces. Estimates based on this approach for several widely separated upland areas range between 1.2 and 4.7 cm per 1,000 yr for periods of 1.1 to 10.8 million years, and the differences in these average rates show no apparent relation to regional variations in late Tertiary and Quaternary vertical tectonic activity. Degradation of upland areas in the Yucca Mountain region is relatively slow, with average downwasting rates over the last 1 to 5 million years probably between 0.5 to 2.0 cm per 1,000 yr on lower hillslopes and proximal piedmont areas and less than 0.5 cm per 1,000 yr in middle and distal piedmont areas. Thus, it would appear that the general degradation of upland areas in the region surrounding Yucca Mountain is proceeding relatively slowly.

The sporadic nature and limited areal extent of individual precipitation events are major impediments to an accurate characterization of present-day

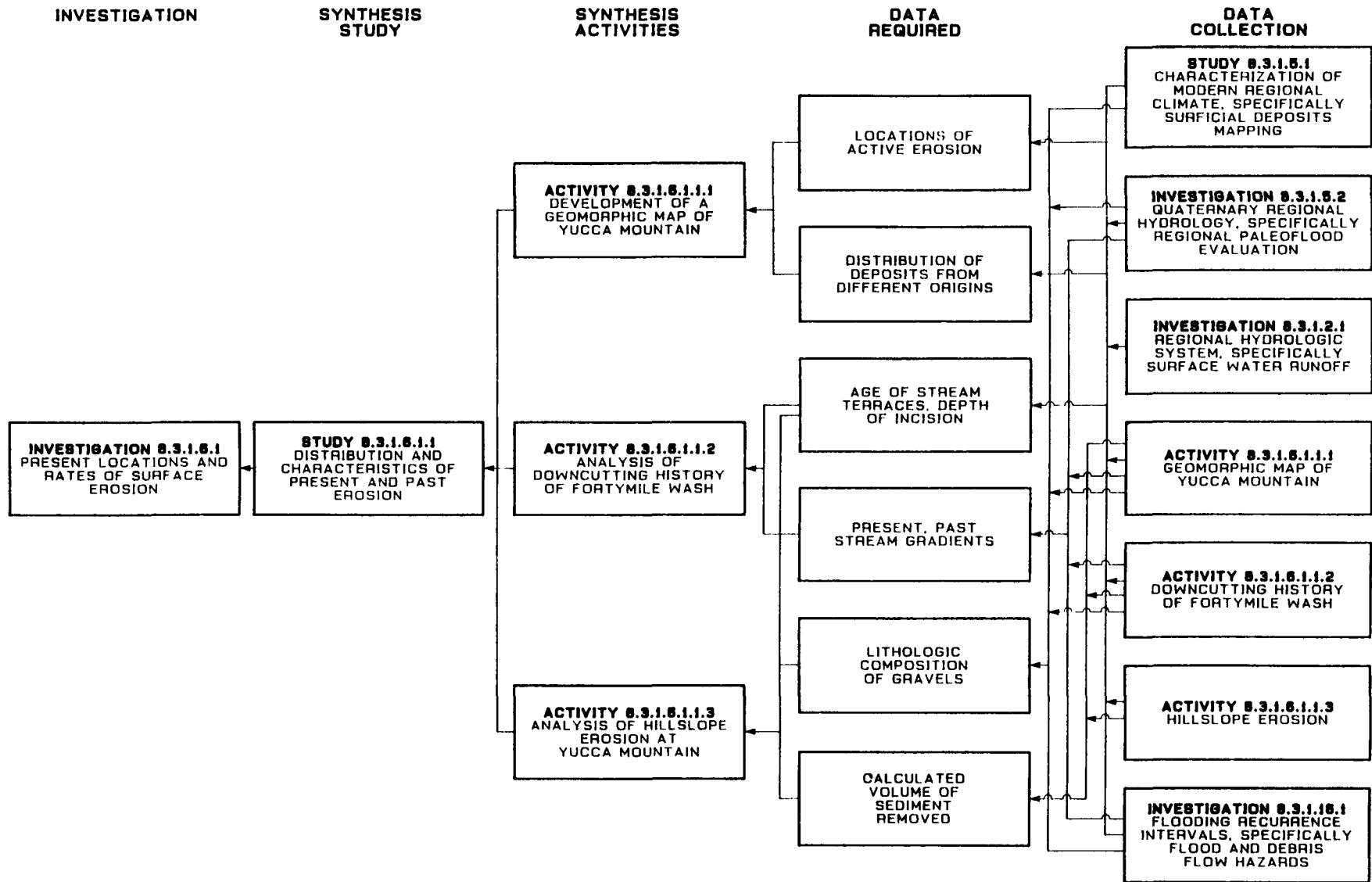

Figure 8.3.1.6-2. Logic diagram for Investigation 8.3.1.6.1.

CONSULTATION DRAFT

erosion. Few data have been collected in the Great Basin to correlate individual storm events with corresponding volumes of sediment transported out of a basin with the associated storm runoff. Because the storms can be of very limited areal extent, a single storm may cause measurable hillslope erosion and flooding in one tributary, while not providing sufficient precipitation to an adjacent tributary to cause runoff. Furthermore, the next storm to cause measurable erosion on the same hillslope may occur in the same month, or not for several years or even decades. The sporadic nature of these storms causes the complex response of the fluvial systems.

Complex response is a term applied to the reaction of a fluvial system to a disruption of the equilibrium of the system. Such disruptions can be due to base-level lowering, tectonic uplift or tilting, climatic change, or human activity. The disruption of equilibrium causes a critical threshold to be exceeded (Chapter 1, Section 1.1), and the system does not respond uniformly throughout. The lower-order tributary streams of the system do not respond at the same rate as the main channel (e.g., Fortymile Wash and its tributaries). In the example of base-level lowering, a pulse of erosion along the main channel will result in rejuvenation of the tributaries. The influx of sediment from the rejuvenated tributaries can result in aggradation on the main channel, and downcutting may stop until such a time when the aggraded material has been removed. When the system has removed the aggraded material, another episode of erosion may occur. Thus, erosion is episodic and depends on the response of the entire system (Matthusen, 1986).

Direct measurement of present rates of erosion at Yucca Mountain may be difficult to obtain over the next several years of site characterization. Stream gaging equipment has been installed and more stations are planned, but there is no guarantee that a variety of storms will take place over these specific drainages during the next few years. Even if storm events do occur, the characterization of erosion locations and calculated rates of erosion may be based on limited observations and collected discharge and sediment data, and may not accurately reflect long-term erosion rates.

Indirect measurements are thus necessary to supplement direct measurements to better characterize recent hillslope erosion and floods. These measurements include the evaluation of flood and debris-flow hazards from Holocene deposits and discharge volumes of paleofloods calculated from maximum particle size and engineering analysis techniques. These activities are all included within the characterization of the regional meteorology; description of the regional surface-water system (Study 8.3.1.2.1.2), regional meteorology (Section 8.3.1.2.1.1), geomorphic information (Section 8.3.1.5.1), paleoflood evaluation (Activity 8.3.1.5.2.1.1), and site flood debris-hazards studies (Activity 1.6.1.1.1).

One study, consisting of three activities, will be performed in support of Investigation 8.3.1.6.1. The study will focus on the identification and quantification of active erosional processes. Data on these processes and stream-incision rates will be used to determine the cause of downcutting in Fortymile Wash.

CONSULTATION DRAFT

8.3.1.6.1.1 Study: Distribution and characteristics of present and past erosion

The objectives of this study are to identify the erosional processes that have been operating in the Yucca Mountain area during the Quaternary, to identify the specific locations of past erosion, and to quantify the rates of the different processes and assess their relative importance.

A geomorphic map of the Yucca Mountain area will delineate erosionally active and stable areas, and will correlate the various surficial deposits with those geomorphic processes responsible for their origin. Investigation of the downcutting history of Fortymile Wash will yield ages of stream terraces, depths of stream incision, stream gradients, and lithologies of stream gravels, which will aid in identifying the controls on local stream incision.

8.3.1.6.1.1.1 Activity: Development of a geomorphic map of Yucca Mountain

Objectives

The objectives of this activity are to (1) determine the areal distribution of active erosional areas and geomorphically stable areas and (2) determine the spatial distribution of the different types of geomorphic processes and associated deposits.

Parameters

The parameters for this activity are

1. The locations of areas of active erosion.
2. The locations of geomorphically stable areas and the distribution of deposits originating from different geomorphic processes.

Description

The distribution of landforms and areas of present and past erosion at Yucca Mountain will be shown on a geomorphic map of the area. The map will show areas of modern erosion and the stable areas that are largely unaffected by modern erosion. Accurate distribution of areas of modern erosion is important for calculation of present and future erosion rates.

The geomorphic map will be a derivative map of the surficial deposits map (Activity 8.3.1.5.1.4.3). The surficial deposits map will show the types and ages of surficial deposits on the landscape. The geomorphic map will show landforms (both bedrock and surficial deposits) and the types of past and present geomorphic processes that are chiefly responsible for their formation. Ages of deposits can be used to infer the relative stability or instability of the landforms. The geomorphic map will be constructed from much of the aerial photographic interpretation and field checking of deposits and map-unit contacts that will be undertaken during preparation of the surficial deposits map (Activity 8.3.1.5.1.4.3). Dating of surficial deposits

CONSULTATION DRAFT

will also be accomplished in the surficial deposits map activity. The geomorphic interpretation of the surficial deposits will be primarily based upon the interpretations of origins from other paleoenvironmental studies of Yucca Mountain (Study 8.3.1.5.1.4) and reported in the synthesis of the Quaternary history of Yucca Mountain (Activity 8.3.1.5.1.5.1).

Methods and technical procedures

The method and technical procedure for Activity 8.3.1.6.1.1.1 is given in the following table.

Method	Technical procedure		
	Number	Title	Date
	(NWM-USGS)		
Preparation of a geomorphic map of Yucca Mountain from the surficial deposits map	GP-01, R0	Geologic mapping	11 Mar 83

8.3.1.6.1.1.2 Activity: Analysis of the downcutting history of Fortymile Wash and its tributaries

Objectives

The objectives of this activity are to (1) determine stream-incision rates on Fortymile Wash and selected tributaries and (2) determine the cause(s) of the major downcutting episode(s) on Fortymile Wash.

Parameters

The parameters for this activity are

1. The ages of stream terraces.
2. The depths of stream incision.
3. Present and past stream gradients.
4. The lithologic composition of stream gravels.

Description

Fortymile Wash is a major geomorphic feature situated about 3 km east of the proposed repository site. The wash flows south out of the Timber Mountain caldera drainage basin, about 680 km² in size, and is incised 20 to 25 m into Quaternary deposits along its course east of Yucca Mountain. Dune, Sevier, and Yucca Washes are incised from 2 to 25 m into Quaternary deposits. These washes and their tributaries are incised as much as 100 m into bedrock dip slopes along the fault and fracture zones on the east side of Yucca Mountain.

CONSULTATION DRAFT

Rates of stream incision are greater than surface degradation rates, and the downcutting of the Fortymile Canyon represents the highest localized erosion rates for the Yucca Mountain area. The average rate of stream incision below the main stream terrace is about 8.5 cm per 1,000 yr. However, the age of the stream terrace is based not on a direct radiometric age, but on the correlation to isotopically dated deposits with similar soil development. In this activity, all major stream terraces on Fortymile Wash will be dated by either uranium-trend, uranium-series, rock varnish (cation ratios), or radio-carbon methods. By dating all terraces, average incision rates can be refined for specific intervals of downcutting between episodes of valley aggradation and subsequent terrace formation. Terraces on Fortymile Wash tributaries will be dated in an effort to refine the youngest episodes of valley aggradation and incision. These site-specific incision rates will be used to calculate future erosion rates near the repository. This information may also be valuable for interpreting the paleoenvironmental history of Yucca Mountain (Activity 8.3.1.5.1.4).

Another aspect of this activity is to determine the cause or causes for the downcutting of Fortymile Canyon, which is unusually deep compared with other canyons in Great Basin piedmonts and basins. To identify contributing factors to this unique geomorphic feature, former stream gradients will be reconstructed from stream terrace profiles, and stream gravel lithologic compositions will be examined to identify any changes in upper basin source areas. These two activities will help in deciding if stream capture was a major factor in the formation of Fortymile Wash. Also, all relevant subsurface information, including both drillhole and geophysical data, will be examined to decide if Fortymile Wash is situated along a fault or fault zone.

Methods and technical procedures

The methods and technical procedures for Activity 8.3.1.6.1.1.2 are given in the following table.

Method	Technical procedure		
	Number	Title	Date
	(NWM-USGS)		
Dating of major terraces on Fortymile Wash	GCP-02, R1	Labeling, identification, and control of geochronology samples and separates	20 Jan 87
	GCP-04, R0	Uranium-Trend Dating	15 June 81
	GCP-03, R0	Uranium-Series Dating	15 June 81
	TBD ^a	Cation ratio (desert varnish) dating	TBD

CONSULTATION DRAFT

HQ MARKUP/FDP-1
8-Dec-87/#117

Method	Technical procedure		Date
	Number	Title	
	(NWM-USGS)		
	TBD (in preparation)	Radiocarbon dating	TBD
Generation of stream gradients from stream terrace profiles	TBD	Generation of stream gradients	TBD
Determination of lithologic compositions of stream gravels	GP-03, RO	Stratigraphic studies	1 Mar 83
Analysis of subsurface data to determine possibility of Fortymile Wash being situated along a fault or fault zone	GP-02, RO	Subsurface investigations	1 Mar 83

^aTBD = to be determined.

8.3.1.6.1.1.3 Activity: An analysis of hillslope erosion at Yucca Mountain

Objectives

The objectives of this activity are to (1) determine the average rates of Quaternary hillslope erosion on Yucca Mountain in bedrock and surficial deposits and (2) determine the genesis and the rates of movement of hillslope deposits.

Parameters

The parameters that will be obtained by this activity are

1. The absolute ages of the rock varnish coatings of bedrock and surficial deposits.
2. Maximum incision depth of hillslopes and adjacent dated surfaces.
3. Descriptions of the textures, grain size distributions, and sedimentary structures of the surficial deposits.
4. The calculated volume of sediment removed from hillslopes by erosional processes.

CONSULTATION DRAFT

Description

The calculation of site-specific erosion rates will be accomplished using a new rock-varnish dating technique. Rock varnish, also called desert varnish, is nearly ubiquitous in arid and semiarid regions. Rock varnish is a thin coat of ferromanganese oxides, clay minerals, and biologic materials accreted on rocks in a variety of environmental settings. Varnished deposits and surfaces can be dated because several mobile cations in the varnish are depleted with time. The ratio of mobile to immobile cations (K+Ca/Ti) decreases with time, providing a relative age sequence for varnishes in a given area (see Section 8.3.1.17.4.9.1).

Absolute age estimates have been determined by calibrating the cation-leaching curve with cation ratios from potassium-argon dated volcanic rocks in Crater Flat and uranium-trend-dated alluvial deposits along the flanks of Yucca Mountain and within the surrounding washes and canyons (Harrington and Whitney, 1987). Maximum incision parallel to the dated hillslope deposits and bedrock surfaces will be measured, and volumes of denuded sediment will be calculated where possible. Erosion rates for both bedrock and surficial deposits will be used to estimate future erosion rates during the postclosure period.

Methods and technical procedures

The methods and technical procedures for Activity 8.3.1.6.1.1.3 are given in the following table.

Method	Technical procedure		Date
	Number	Title	
Rock varnish dating hillslope deposits	TBD ^a	Cation-Ratio (desert varnish) Dating	TBD
Measurement of hillslope erosion	TBD	Measurement of Hillslope Erosion	TBD
Laboratory analysis of hillslope deposits	TBD	Sediment Size Analysis	TBD

^aTBD = to be determined.

8.3.1.6.1.2 Application of results

The information derived from the previously described activities will be used in the following areas of site characterization, repository design, and performance assessment:

CONSULTATION DRAFT

<u>SCP section</u>	<u>Subject</u>
8.3.5.17	Site information needed to identify favorable and potentially adverse conditions at the site that may influence postclosure repository performance (Issue 1.8).
8.3.1.6.2	Potential effects of tectonic activity on locations and rates of erosion
8.3.1.9.1	Natural phenomena and human activities that might degrade surface markers and monuments
8.3.1.14	Surface characteristics program
8.3.3.2	Seal characteristics
8.3.2.5	Technical feasibility

8.3.1.6.1.3 Schedule and milestones

The schedule and milestone information for this investigation is given in Section 8.3.1.6.4.3, at the end of Investigation 8.3.1.6.4 (potential effects of erosion on hydrologic, geochemical, and rock characteristics).

8.3.1.6.2 Investigation: Potential effects of future climatic conditions on locations and rates of erosion

Technical basis for obtaining the information

Link to the technical data chapters and applicable support documents

Sections 1.1.3 and 5.2.2 of the SCP data chapters provide a technical summary of existing data relevant to this investigation. Section 1.1.3 addresses the influence of climate on geomorphic processes, average erosion rates in the region surrounding Yucca Mountain, and significant late Quaternary geomorphic processes in the Yucca Mountain area. Future climatic variations and conceptual models used to investigate future climatic variation are presented in Section 5.2.

Parameters

This investigation will synthesize the results of studies undertaken in support of Investigations 8.3.1.5.1 (nature and rates of climate change) and 8.3.1.6.1 (present locations and rates of surface erosion). Thus, the parameters themselves are the results and conclusions from these studies. The parameters that will be used as input to this investigation are (1) predicted climate of the Yucca Mountain region over the next 1,000 to 100,000 yr, including the predicted timing of climatic changes, and the nature and

CONSULTATION DRAFT

duration of predicted climatic episodes; (2) the present locations and rates of surface erosion; and (3) the distribution and characteristics of past erosion.

Purpose and objectives of the investigation

An estimate of the potential effects of future climate on locations and rates of erosion will be derived in this investigation from converging lines of evidence. Figure 8.3.1.6-3 shows how information from Investigation 8.3.1.5.1 and from the activities within Investigation 8.3.1.6.1 will be used to determine potential effects of future climatic conditions on locations and rates of erosion. A projected sequence of climatic episodes, including the timing for their initiation and duration, will result from the climate modeling for Investigation 8.3.1.5.1. An ancillary product of the preparation for modeling will be a correlation of the paleoclimatic history of the southern Great Basin with the paleoenvironmental history of Yucca Mountain (erosional and depositional responses to climate). From the studies for Investigation 8.3.1.6.1 will come a characterization of present and past locations and rates of erosion in the Yucca Mountain region. Fitting the projected future climate sequence with corresponding known erosion rates and past geomorphic responses will allow the quantification of erosion effects at Yucca Mountain over the next 10,000 yr.

Yucca Mountain lies within one of the warmest and driest regions of the United States, with mean annual precipitation averaging about 110 mm per year and relative humidity commonly ranging between 25 and 55 percent. The full-glacial climate in the southern Great Basin is thought to have been semiarid in the basins and lower ranges, although subhumid climates may have existed in the highest mountains. Mean annual temperatures during full glacials were probably about 7 to 10°C colder than at present; annual precipitation was less than 40 percent greater than at present. Glacial processes were probably not active in the Yucca Mountain area during most or all of the Quaternary; lacustrine processes in the Great Basin appear to have been confined to playas, and lacustrine records from the southern Great Basin do not indicate deep lakes or continuous deposition during the late Quaternary.

The semiarid to arid climates of the past and present are responsible for low rates of weathering at Yucca Mountain. Physical weathering appears to be chiefly confined to exposed bedrock hillslopes and piedmont surfaces. Modern surface flow and sediment transport are brief and intermittent.

A future episode of increased precipitation would probably cause an increase in erosion rates. An estimate for (1) the timing, duration, and probability of an expected episode of increased erosion and (2) the expected quantitative effects of the episode at different locations in the Yucca Mountain region (e.g., stream incision versus hillslope erosion) will be made. Anticipated geomorphic responses to possible predicted increases in precipitation at Yucca Mountain will be based on past erosional responses to full pluvial climates during the Quaternary (Study 8.3.1.5.1.4).

One study, consisting of one activity, will be performed in support of this investigation. The study will be a synthesis of the results from activities in support of Investigations 8.3.1.5.1 and 8.3.1.6.1.

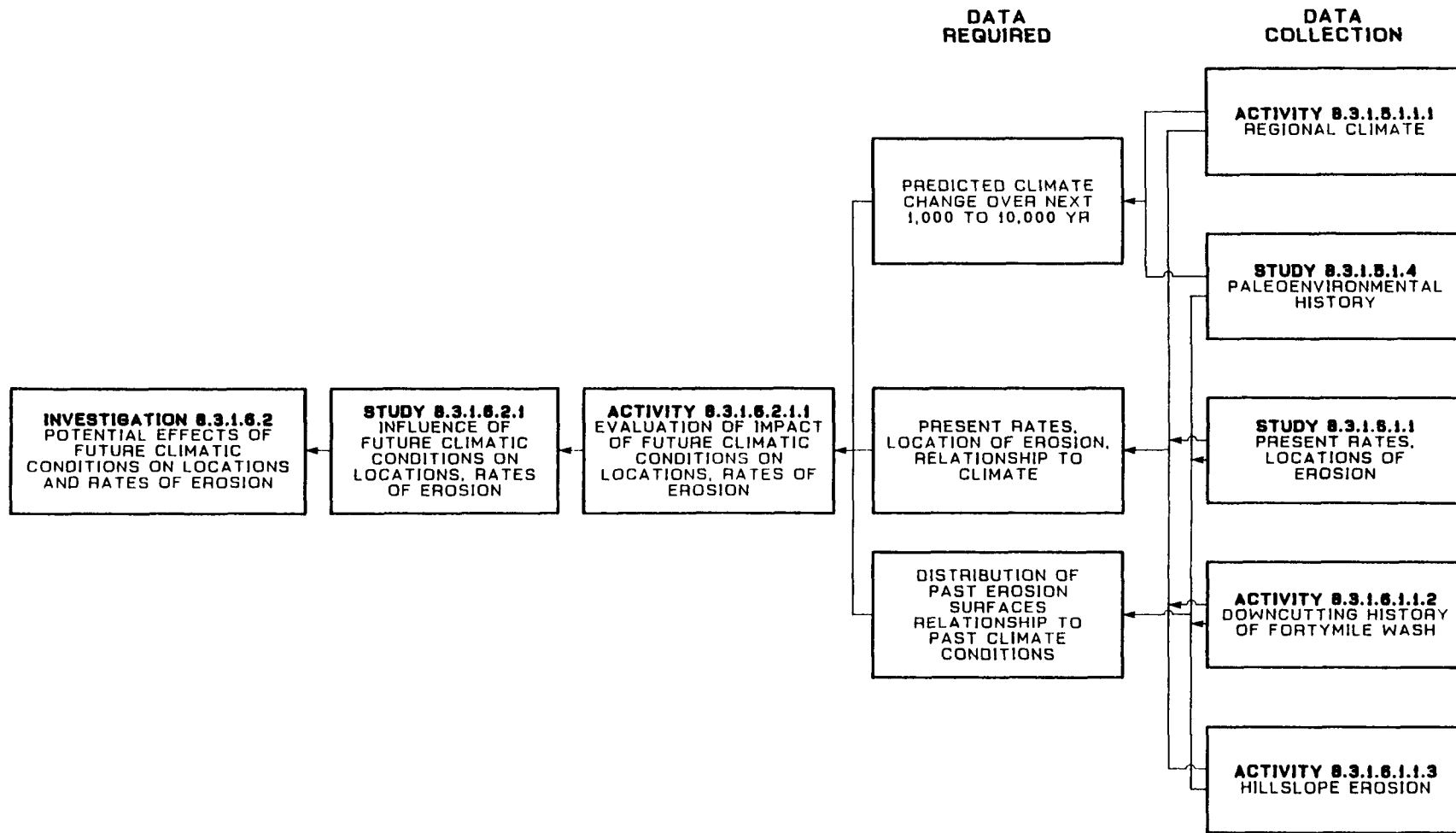

Figure 8.3.1.6-3. Logic diagram for Investigation 8.3.1.6.2.

CONSULTATION DRAFT

8.3.1.6.2.1 Study: Influence of future climatic conditions on locations and rates of erosion

The objectives of this study are to determine the effects of future climatic conditions on the locations and rates of erosion. This synthesis study will use climate and erosion parameters generated by Investigations 8.3.1.5.1 and 8.3.1.6.1 to identify areas and rates of potential stream incision and increased erosion.

8.3.1.6.2.1.1 Activity: Synthesis and data evaluation of impact of future climatic conditions on locations and rates of erosion

Objectives

The objective of this activity is to integrate Quaternary climate conditions and rates of surface erosion with predicted conditions of future climate, to estimate significant changes in the character, distribution and ratio of surface erosion in the Yucca Mountain region over the next 1,000 to 100,000 yr.

Parameters

Three sets of parameters will be evaluated in this activity:

1. The predicted climate of the Yucca Mountain region over the next 1,000 to 100,000 yr, including the predicted timing for climatic changes and the nature and duration of predicted climatic episodes.
2. The present locations and rates of surface erosion and their relationship to present climatic conditions.
3. The distribution and characteristics of past erosion and their relationship to past climatic conditions.

Description

One of the expected results of Investigation 8.3.1.5.1 will be the derivation of regional climate history for the Quaternary from paleolimnologic and terrestrial paleoecologic lines of evidence (Studies 8.3.1.5.1.2 and 8.3.1.5.1.3). However, another product of this investigation will be a synthesis of the site-specific Quaternary paleoenvironmental history of Yucca Mountain and surroundings, on the basis of local surficial deposits, soils, and past geomorphic processes (Study 8.3.1.5.1.4). The paleoenvironmental evaluation will focus on the geomorphic responses to paleoclimates and climatic changes. The evaluation will also incorporate data on distribution and characteristics of past erosion. A paleoclimate-paleoenvironmental synthesis (Study 8.3.1.5.1.5) will tie the paleoclimate history (especially known episodes of temperature and precipitation extremes) to dated responses in the depositional and geomorphic record that reflect these extremes. A possible example would be correlating an episode of higher precipitation, as evidenced by the palynology of lacustrine sediments, to a period of rising base levels as reflected in a dated period of stream aggradation or reduced incision.

CONSULTATION DRAFT

Thus, the paleoenvironmental history can serve as the baseline study to examine the relationship between different climatic episodes and the geomorphic responses that controlled erosion during the Quaternary. These responses can then be applied to future predicted climates, from which predicted erosion rates can be calculated.

To determine the effects of future climate on erosion, it will be necessary to integrate the results from Investigation 8.3.1.5.1 (nature and rates of climate change) with those from Investigation 8.3.1.6.1. The first important result of the latter studies will be the correlation of locations (e.g., stream incision) and rates of erosion to present climatic conditions. The second will be the determination of erosion rates and distribution of fluvial and hillslope processes during the Quaternary. By combining Quaternary erosion rates with the correlation between the regional paleoclimatic and local paleoenvironmental histories, together with the predicted future climates, it will be possible to describe expected locations and rates of erosion in response to expected future climatic episodes. If the durations of the future climatic episodes can be reasonably estimated, it will then be possible to quantify the effects of erosion at Yucca Mountain over the next 1,000 to 100,000 yr.

Methods and technical procedures

The methods and technical procedures for Activity 8.3.1.6.2.1.1 is given in the following table.

Method	Technical procedure		
	Number	Title	Date
Synthesis: Evaluation of future climatic effects on locations and rates of erosion at Yucca Mountain, using results of studies and activities from Investigations 8.3.1.5.1 and 8.3.1.6.1	TBD ^a	Data synthesis	TBD

^aTBD = to be determined.

8.3.1.6.2.2 Application of results

The information derived from the studies and activities of the plans described previously will be used in Investigation 8.3.1.9.1.

CONSULTATION DRAFT

8.3.1.6.2.3 Schedule and milestones

The schedule and milestone information for this investigation is given in Section 8.3.1.6.4.3, at the end of Investigation 8.3.1.6.4 (potential effects of erosion on hydrologic, geochemical, and rock characteristics).

8.3.1.6.3 Investigation: Studies to provide the information required to determine the potential effects of future tectonic activity on locations and rates of erosion

Technical basis for obtaining the information

Link to the technical data chapters and applicable support documents

The following sections of the SCP data chapters provide a technical summary of existing data relevant to this investigation. Section 1.3.2 discusses the structures and structural history of Yucca Mountain and the vertical and lateral crustal movement as they relate to tectonic activity. Section 1.1.3 examines the influence of tectonism on geomorphic processes and its effects on average erosion rates in the Yucca Mountain area and discusses significant late Quaternary geomorphic processes in the Yucca Mountain area.

Parameters

Four sets of parameters will be used in the site studies planned to obtain the needed information. This investigation is necessarily a synthesis of the results of studies undertaken to satisfy other investigations. Rates of regional uplift and subsidence, as determined from studies of tectonic geomorphology and the geodetic leveling network, will be supplied from Investigation 8.3.1.8.2. The present and past locations and rates of surface erosion will be determined from the geomorphic map. The effects of future climate on erosion will be obtained from Investigation 8.3.1.6.2.

Other site studies that provide data that support the determination of the parameters needed for this investigation include (1) a synthesis of the paleoenvironmental history of the Yucca Mountain region from Study 8.3.1.5.1.4 and (2) the tectonic model synthesis from Section 8.3.1.17.4.12.

Purpose and objectives of the investigation

Estimates of the potential effects of future tectonic activity on locations and rates of erosion will be derived in this investigation using information from Investigation 8.3.1.8.2, from Investigation 8.3.1.5.1, and from other activities performed within this program. The logic diagram for this investigation is shown in Figure 8.3.1.6-4.

Geomorphic processes in the southern Great Basin and northern Mojave Desert are determined largely by climate, existing topography, and tectonic activity, and by the spatial and temporal relations between these determinants. Late Cenozoic extensional tectonism and a predominantly semiarid-to-arid climate have combined to produce a structurally dominated landscape of high relief with narrow, rugged uplands separated by broad, gently sloping

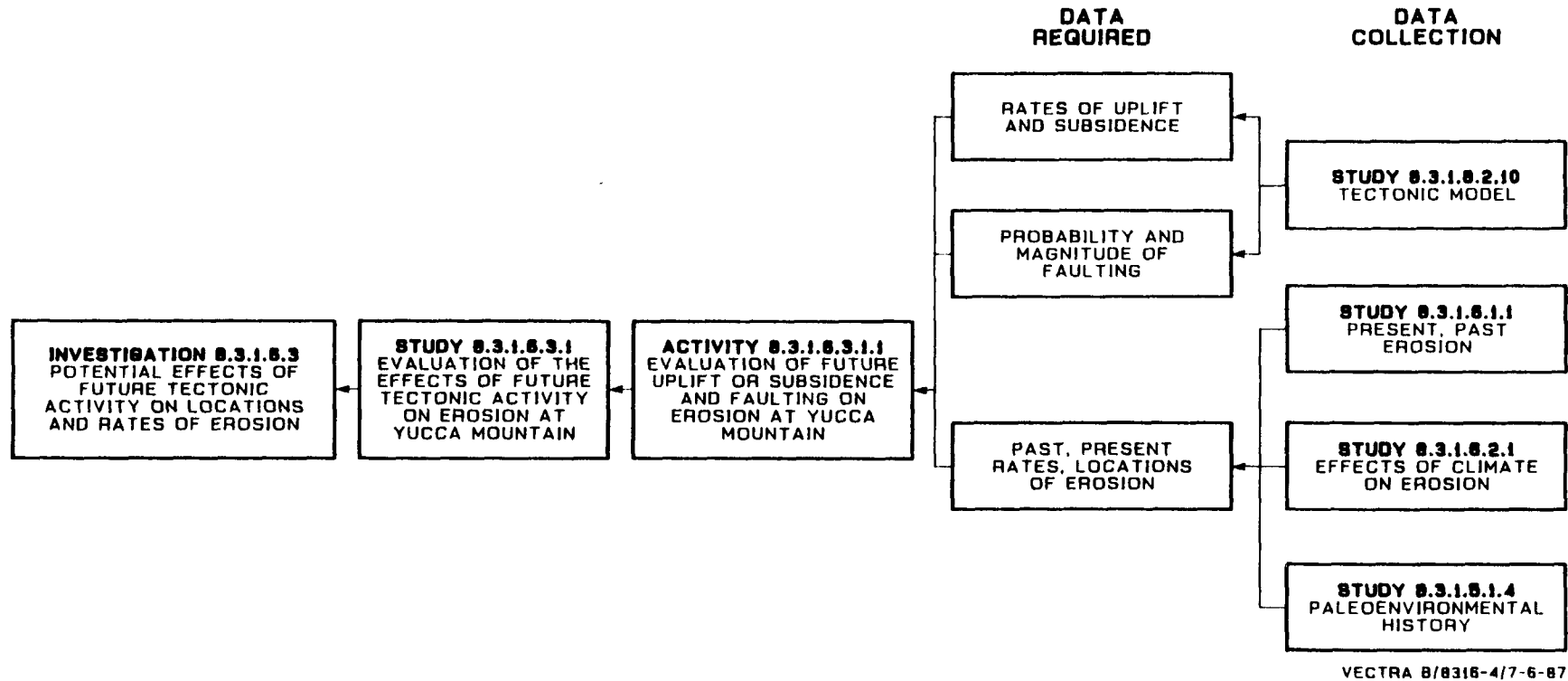

Figure 8.3.1.6-4. Logic diagram for Investigation 8.3.1.6.3.

CONSULTATION DRAFT

lowland basins. Within this landscape, erosion and erosional processes are concentrated in the high, steep, and relatively moist uplands, whereas deposition and depositional processes are generally concentrated in the low, gently sloping, and relatively arid lowlands. The intervening piedmonts serve primarily as surfaces of transport between the eroding uplands and aggrading basins.

Differential vertical movement induced by regional extensional tectonism has probably been the single most important factor in the development of the landscape of the region surrounding Yucca Mountain. Essentially all landscape elements in the southern Great Basin and northern Mojave Desert are the structurally dominated products of late Cenozoic tectonism. However, with the exception of the southwest Great Basin and its bounding fault zones, tectonism appears to have played a much less significant role in regional landscape evolution during the Quaternary. For example, regional morphometric analyses indicate that large areas of the northern Mojave Desert and southern Great Basin (in particular, the eastern and southern sections of the Goldfield block of the Walker Lane belt as discussed in Chapter 1, geology) have undergone little, if any, vertical tectonic activity during the Quaternary. Local tectonic stability since latest Miocene time is documented by relations between potassium-argon-dated lava flows and relict and active erosion surfaces near the Cima volcanic field in the northeastern Mojave Desert and in the Pancake and Reville Ranges of the central Great Basin. In the Yucca Mountain area, average rates of relative vertical tectonic adjustment during the latest Tertiary and Quaternary have been less than 3 cm per 1,000 yr. The impact of extensional tectonism on the late Quaternary landscape of Yucca Mountain has been extremely small, and the impact upon the magnitude and distribution of degradational processes in the area is very local, even in the vicinity of Quaternary faults.

If uplift rates at Yucca Mountain during the postclosure period are negligible, then (using present estimates of erosion rates) the average erosion rate of the mountain would probably be about 1 m over the next 10,000 yr. If the estimated Quaternary rate of uplift is projected over the postclosure period, even with a return to pluvial conditions, it is highly unlikely that the average rate of erosion will increase significantly. These regional erosion and uplift rates need to be verified with the site specific data from Yucca Mountain.

One study will be undertaken under Investigation 8.3.1.6.3. The study consists of one synthesis activity that will integrate data generated from tectonics investigations and from Investigations 8.3.1.6.1 and 8.3.1.6.2.

8.3.1.6.3.1 Study: Evaluation of the effects of future tectonic activity on erosion at Yucca Mountain

The objective of this study is to identify the potential effects of tectonic activity on erosion at Yucca Mountain during the postclosure period. The study is aimed at (1) defining those components of erosion that are dependent upon tectonic activity, and (2) determining how future tectonic adjustment might influence local incision rates.

CONSULTATION DRAFT

8.3.1.6.3.1.1 Activity: Synthesis and data evaluation of the impact of future uplift or subsidence and faulting on erosion at Yucca Mountain and vicinity

Objectives

The objectives of this activity are to estimate (1) the effects of tectonic activity on erosion over the repository postclosure period on the basis of probable future tectonic scenarios for the Yucca Mountain region, (2) the locations and rates of present and past erosion for present climatic conditions, and (3) the effects of future climatic conditions on erosion.

Parameters

Four sets of parameters will be evaluated in this activity:

1. The rates of regional uplift and subsidence, as determined from studies of tectonic geomorphology Section 8.3.1.17.4.9, and the geodetic leveling network in Section 8.3.1.17.4.10.
2. The tectonic model synthesis, including the probability and expected magnitude of faulting in the Yucca Mountain area during the repository postclosure period from Section 8.3.1.17.2 and 8.3.1.17.4.
3. Present and past locations and rates of erosion from Investigation 8.3.1.6.1.
4. Estimated effects of future climate on erosion from Investigation 8.3.1.6.2.

Description

This synthesis activity will be aimed at identifying the magnitudes of the components of erosion rate (both local and regional) caused by Quaternary tectonic activity, and assessing the effects of probable future tectonic activity on rates of erosion expected in the Yucca Mountain region over the repository postclosure period. The tectonic data for this synthesis will be derived from Programs 8.3.1.8. and 8.3.1.17. Erosion rate data will come from Study 8.3.1.6.1.1 (distribution and characteristics of present and past erosion), Activity 8.3.1.6.1.1.3 (hillslope erosion), Activity 8.3.1.6.2.1.1 (impact of future climatic conditions on erosion), and Study 8.3.1.5.1.4 (paleoenvironmental history of Yucca Mountain region).

The apportionment of local and regional erosion rates (Quaternary through present) into components attributed to climatic and tectonic causes will be critical to this activity. Although climatic conditions are believed to be the dominant control on erosion rates, proposed studies on past erosion in the Yucca Mountain region and the reconstruction of the paleoenvironmental history will yield a quantification of the tectonic erosional component for the Quaternary. Combining local data with projected regional uplift or subsidence rates, and probable local fault movement, will result in quantitative estimates for the tectonic influences on erosion rates in the postclosure period.

CONSULTATION DRAFT

Methods and technical procedures

The method and procedure for Activity 8.3.1.6.3.1.1 is given in the following table.

Method	Number	Technical procedure	
		Title	Date
Synthesis: Estimate of the effects of tectonic activity on erosion using the results and conclusions of studies and activities for Investigations 8.3.1.5.1, 8.3.1.6.1, 8.3.1.6.2, 8.3.1.8.2	Needed	Data synthesis	TBD ^a

^aTBD = to be determined.

8.3.1.6.3.2 Application of results

The information derived from the studies and activities in this investigation (8.3.1.6.3) will be used in Investigation 8.3.1.9.1 (degradation of markers).

8.3.1.6.3.3 Schedule and milestones

The schedule and milestone information for this investigation is given in Section 8.3.1.6.4.3, at the end of Investigation 8.3.1.6.4 (potential effects of erosion on hydrologic, geochemical, and rock characteristics).

8.3.1.6.4 Investigation: Potential effects of erosion on hydrologic, geochemical, and rock characteristics

Because existing data on the effects of erosion on hydrology, geochemistry and rock characteristics satisfy the design and performance requirements, no further studies are planned. Instead, a topical report will be prepared by the NNWSI Project to document the tentative conclusion that erosion will have a negligible effect on the hydrologic, geochemical, and rock characteristics important to waste isolation. The steps to be used in addressing this investigation are shown in Figure 8.3.1.6-5.

DOCUMENTATION

**DATA COLLECTION
AND SYNTHESIS**

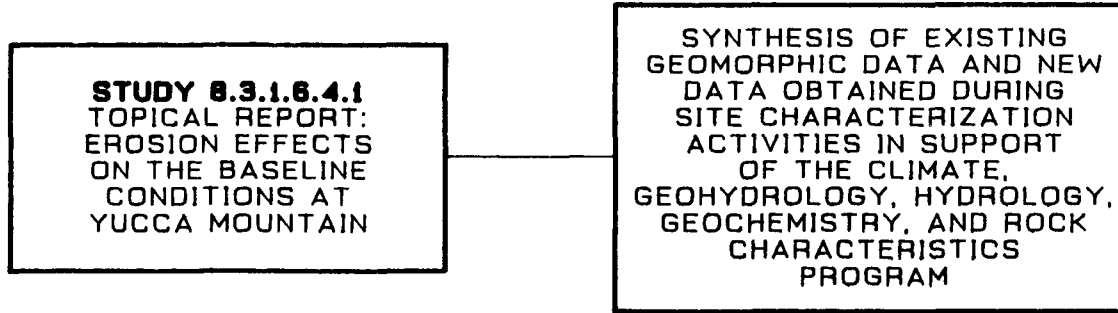

VECTRA B/8316-5/7-6-87

Figure 8.3.1.6-5. Logic diagram for Investigation 8.3.1.6.4.

CONSULTATION DRAFT

Technical basis for obtaining the information

Link to the technical data chapters and applicable support documents

The following sections of the SCP data chapters summarize the information related to this investigation:

<u>SCP section</u>	<u>Subject</u>
1.1.3.2	Average erosion rates in the region surrounding Yucca Mountain
1.1.3.3	Significant late Quaternary geomorphic processes in the Yucca Mountain area
1.8.1.1.2	Discussion of significant results (geomorphology)
1.8.3.1	Information needs bearing on geomorphology
2.1, 2.2, 2.3	Mechanical properties of rock units
2.4, 2.5	Thermal and thermomechanical properties
2.6	Existing stress regime
2.7	Special geoengineering properties
2.8	Excavation characteristics
3.7.1	Areas of recharge and discharge
3.7.2	Regional ground-water flow paths
3.9.3	Conceptual model for ground-water flow system
3.9.4	Calculations of ground-water velocity and travel time
3.10	Summary Sections
4.1	Baseline geochemical characteristics at Yucca Mountain

Parameters

The parameters for this investigation are:

1. The expected effects of erosion on hydrologic, geochemical and rock characteristics during the 10,000 yr postclosure period.
2. The probability that the repository will be exhumed during the next 10,000 and 100,000 yr.

CONSULTATION DRAFT

Purpose and objectives of the investigation

The product of this investigation, a topical report, will address the possibility that erosional processes at Yucca Mountain could adversely affect the potential for radionuclide releases to the accessible environment because of changes in the ground-water system, the geochemical conditions, or the rock characteristics. The likelihood of radionuclide releases because of changes in the hydrologic system is negligible. The probability that erosion will modify the surface-water regime during the postclosure period is extremely small. For erosion-induced changes in hydrologic characteristics to adversely affect waste isolation, a reduction in ground-water travel time resulting from the removal of enough rock above the water table to modify hydraulic gradients and locations of recharge or discharge near Yucca Mountain would be necessary. It is highly unlikely that expected erosion rates (even considering possible changes in climate and tectonism) will be adequate to cause the removal of sufficient overburden material necessary to change the hydrologic conditions.

Erosion-induced changes in geochemical characteristics that might adversely affect waste isolation most likely would be changes in geochemical properties along flow paths to the accessible environment. The effects of erosion on the geochemical properties along flow paths for both ground water and gases will be discussed in the topical report. Erosion is expected to have negligible effects on mechanical, thermal, or thermomechanical properties, on special geoengineering properties, or on excavation characteristics within the controlled area in ways that would affect waste isolation. Erosion may very slightly modify in situ stresses, but the expected amount of erosion within the controlled area and the corresponding change in in situ stress is so small that effects on waste isolation will be negligible.

One study, consisting of a synthesis activity and an analysis activity, will be undertaken in support of this investigation. The objective of the synthesis activity is to integrate the existing erosion data and additional erosion data that will be obtained from Investigations 8.3.1.6.1 through 8.3.1.6.3, with information on the hydrologic, geochemical, and rock characteristics. These data will be used to develop a topical report that will address the expected effects of erosion on conditions at the site needed to address the requirements of 10 CFR Part 60.

The objective of the analysis activity is to apply statistical techniques to information obtained from Investigations 8.3.1.6.1 through 8.3.1.6.3 to determine with a high level of certainty the probability that repository exhumation by erosional processes will not occur over the next 10,000 and 100,000 yr. The results of the statistical analysis will be presented in a topical report.

CONSULTATION DRAFT

8.3.1.6.4.1 Study: Development of a topical report to address the effects of erosion on the hydrologic, geochemical, and rock characteristics at Yucca Mountain

Objectives

The objective of this study is to assemble data showing the expected effects of erosion on (1) the hydrologic, geochemical, and rock characteristics of the controlled area and (2) the ability of the mined geologic disposal system to effectively isolate waste over 10,000 and 100,000 yr after disposal.

Parameters

The following parameters will be considered in the topical report:

1. Rates and locations of future erosion.
2. Depth to water table in the controlled area.
3. Geochemical process along flow paths to the accessible environment.
4. Effect of erosion on retardation of radionuclides by all geochemical processes along ground-water flow paths and gaseous flow paths.
5. Effects of erosion on in situ stresses in the controlled area.

Description

Two topical reports will be prepared that will assemble and analyze existing data and data gathered during site characterization. The first report will address the expected magnitude of erosion in the controlled area and on the extent to which such erosion would reduce ground-water travel time to the accessible environment. The report will also identify and address the expected effects of erosion on the geochemical characteristics along flow paths and the expected effects of erosion on the in situ stresses in the controlled area.

In the second report, existing information and data obtained during site characterization will be used in performing statistical calculations to determine the probability that erosion of overburden materials will result in repository exhumation during 10,000 and 100,000 yr after closure.

Methods and technical procedures

There are no methods and technical procedures for Study 8.3.1.6.4.1.

8.3.1.6.4.2 Application of results

The topical report on the effects of erosion on geohydrology, rock characteristics, and geochemistry will serve as a basis for interaction with the NRC to establish that the data base on erosion is sufficient to terminate

CONSULTATION DRAFT

further erosion-related site studies. Additional consideration of erosion as a potentially disruptive scenario is necessary for both Issue 1.1 (total system performance, Section 8.3.5.13) and Issue 1.8 (NRC siting criteria, Section 8.3.5.17). The second topical report will present statistical analyses to support the position that the current information is sufficient to resolve all questions related to erosion effects on postclosure waste containment and isolation at the Yucca Mountain site.

8.3.1.6.4.3 Schedule and milestones

The erosion program consists of four investigations, each of which contain one study: 8.3.1.6.1.1 (distribution and characteristics of present and past erosion), 8.3.1.6.2.1 (influence of future climatic conditions on locations and rates of erosion), 8.3.1.6.3.1 (evaluation of the effects of future tectonic activity on erosion at Yucca Mountain), and 8.3.1.6.4.1 (potential effects of erosion on hydrologic, geochemical, and rock characteristics). In the figure that follows, the schedule information for these studies is presented in the form of timelines. The timelines extend from the implementation of the approved study plans to the issuance of the final products associated with the studies. Summary schedule and milestone information for these studies can be found in Section 8.5.1.1.

The study on present and past erosion (8.3.1.6.1.1) is ongoing. The experimental and modeling work for this entire program will proceed in parallel with characterization, design, and performance activities and will interact with them in an iterative fashion. Rates and potential locations of erosion are needed to evaluate erosion potential at the shaft for Issue 1.12 (seal characteristics, Section 8.3.3.2), to identify stable locations for surface markers for the human interference program (Section 8.3.1.9), and to evaluate erosion potential at bridges and roads for the surface characteristics program (Section 8.3.1.14).

The completion of investigations in this program are constrained by needs for information from other characterization programs. Completion of the milestone reports will require information from Sections 8.3.1.2 (geohydrology program), 8.3.1.3 (geochemistry program), 8.3.1.5 (climate program), 8.3.1.16 (preclosure hydrology program), 8.3.1.8 (postclosure tectonics program), and 8.3.1.4 (rock characteristics program).

The investigation numbers and titles corresponding to the timeline are shown to the left on the following figure. The points shown on the timeline represent major events or important milestones associated with the investigation. Solid lines represent study durations, and dashed lines show interfaces. The data input or output at the interfaces are shown by circles.

CONSULTATION DRAFT

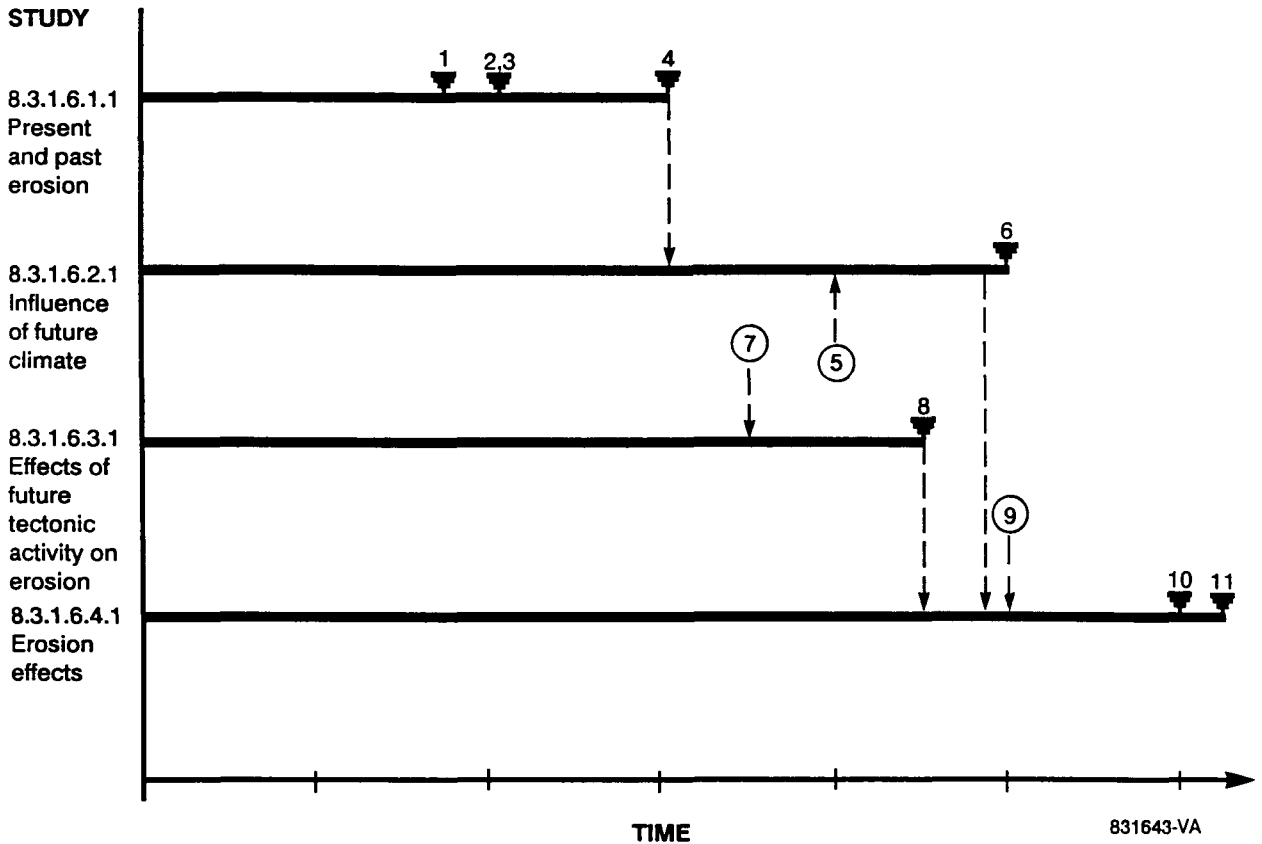

The points on the timeline are described in the following table:

<u>Point number</u>	<u>Description</u>
1	Milestone Z425. Issue report on the origin of hillslope deposits.
2	Milestone Z288. Issue report on the analysis of hillslope erosion.
3	Milestone Z287. Issue report on the analysis of the downcutting history of Fortymile Wash and its tributaries.
4	Milestone Z286. Complete development of geomorphic map of Yucca Mountain.
5	Information received from climate program (Section 8.3.1.5).
6	Milestone Z290. Issue topical report on the evaluation of the impact of future climatic conditions on locations and rates of erosion.

CONSULTATION DRAFT

<u>Point number</u>	<u>Description</u>
7	Information received from postclosure tectonics program (Section 8.3.1.8).
8	Milestone Z292. Issue topical report on the evaluation of the impact of future uplift/subsidence and faulting on erosion at Yucca Mountain and vicinity.
9	Information received from the geohydrology, geochemistry, and rock characteristics programs (Sections 8.3.1.2, 8.3.1.3, and 8.3.1.4).
10	Milestone Z294. Issue topical report on the evaluation of future erosion on baseline conditions at Yucca Mountain and vicinity.
11	Milestone Z498. Issue topical report on the effects of erosion on postclosure containment and isolation at Yucca Mountain.

Nuclear Waste Policy Act
(Section 113)

Section 8.3.1.7

Consultation Draft

ROCK DISSOLUTION



Site Characterization Plan

***Yucca Mountain Site, Nevada Research
and Development Area, Nevada***

Volume V

January 1988

U.S. Department of Energy
Office of Civilian Radioactive Waste Management
Washington, DC 20585

CONSULTATION DRAFT

8.3.1.7 Overview of rock dissolution program: Description of rock dissolution required by the performance and design issues

Because the findings made for the Yucca Mountain environmental assessment (EA) (DOE, 1986b) are adequate to meet the requirements of Issue 1.8 (Section 8.3.5.17, NRC siting criteria) and 1.9 (Section 8.3.5.18, higher level findings-- postclosure system and technical guidelines) no additional studies are specifically planned to resolve this issue. Further work related to chemical and mineralogical changes in the post-emplacement environment are discussed in Section 8.3.4.2.4.1.

8.3.1.7.1 Investigation: Rates of dissolution of crystalline and noncrystalline components in tuff

Technical basis for obtaining the information

Link to technical data chapters and applicable support documents

The following sections of the SCP data chapters provide a technical summary of existing data relevant to this investigation:

<u>SCP section</u>	<u>Subject</u>
4.1.1	Mineralogy and petrology
4.1.1.3.1	The potential host rock
4.1.1.4	Mineral stability
4.1.2	Ground-water chemistry

Parameters

For this investigation, parameters are not applicable.

Purpose and objectives of the investigation

For this investigation, purpose and objectives are not applicable.

Technical rationale for the investigation

This investigation has been satisfied by information presented in the Yucca Mountain EA (DOE, 1986b). The conclusions in the EA were as follows:

1. No evidence of Quaternary dissolution fronts or other dissolution features has been found.
2. None of the minerals in the host rock are considered soluble under expected repository conditions.
3. There is no evidence of past or potential future significant dissolution that would provide a hydraulic interconnection between the host rock and any immediately surrounding geohydrologic unit.

CONSULTATION DRAFT

4. The minerals that compose the rock in and around Yucca Mountain are considered insoluble, and significant subsurface rock dissolution is not a credible process leading to radionuclide releases greater than those allowable under the requirements of 10 CFR Part 960 and 10 CFR Part 60.

Because the findings made for the EA are adequate to meet the higher level findings of 10 CFR Part 960 and 10 CFR Part 60, no additional studies are specifically planned to address this issue. Studies on mineral stability are described in Section 8.3.1.3 (Geochemistry Program). These studies are being done to assess geochemical retardation along flow paths to support the assessments made in Issue 1.1 (total system performance, Section 8.3.5.13).

8.3.1.7.1.1 Application of results

The information generated in this investigation will be used to address higher level findings concerning dissolution (Issue 1.9, Section 8.3.5.18) and the requirements of the NRC siting criteria (Issue 1.8, Section 8.3.5.17).

8.3.1.7.1.2 Schedule and milestones

Investigation 8.3.1.7.1 (dissolution rates) has been satisfied and, therefore, no schedule and milestone information is required.

***Nuclear Waste Policy Act
(Section 113)***

Section 8.3.1.8

Consultation Draft

POSTCLOSURE TECTONICS



Site Characterization Plan

***Yucca Mountain Site, Nevada Research
and Development Area, Nevada***

Volume V

January 1988

***U.S. Department of Energy
Office of Civilian Radioactive Waste Management
Washington, DC 20585***

CONSULTATION DRAFT

8.3.1.8 Overview of the postclosure tectonics program: Description of future tectonic processes and events required by the performance and design issues

Summary of performance and design requirements for postclosure tectonics information

The flow of data through the postclosure tectonics program is shown in Figure 8.3.1.8-1. The performance and design requirements that the postclosure tectonics program must address are to supply data on the probability and effects of tectonic "initiating events" that may alter existing conditions at Yucca Mountain and adversely affect repository performance. These requirements for tectonic information can be summarized as follows:

1. Data on the probability and effects of potentially significant tectonic release-scenario classes addressing both anticipated and unanticipated conditions that are needed for performance assessment calculations of radionuclide releases to the accessible environment (Issue 1.1, Section 8.3.5.13, total system performance).
2. Data required to perform the analysis to determine the degree to which each of the favorable and potentially adverse conditions listed in 10 CFR 60.122 contributes to or detracts from isolation (Issue 1.8, Section 8.3.5.17, NRC siting criteria).
3. Data needed to accommodate requirements for knowledge of site-specific tectonic conditions in design concepts for the geometry, layout, and emplacement borehole locations of the underground facility (Issue 1.11, Section 8.3.2.2, configuration of underground facilities (postclosure)).
4. Data required so that the higher level findings of 10 CFR Part 960 can be evaluated (Issue 1.9a, Section 8.3.5.18, higher level findings (postclosure)).

Four investigations in the postclosure tectonics program provide the analysis and assessment of data necessary to meet these requirements (Figure 8.3.1.8-1). These four investigations have been designed to parallel the intermediate performance measures and initiating events defined in Sections 8.3.5.13 and 8.3.2.2. Investigation 8.3.1.8.3 (tectonic effects on hydrology) has been further subdivided into three separate intermediate performance measures because of the number of performance parameters that have been identified by Issue 1.1 in this investigation. The final column of Figure 8.3.1.8-1 identifies the investigations that will provide data required by Investigations 8.3.1.8.1 through 8.3.1.8.4 in order to complete their analysis and assessment for the postclosure tectonics program. These data collection investigations include Investigation 8.3.1.8.5 which will house the data collecting studies and activities specific to the postclosure tectonics program and investigations from several other programs that provide important data for the analysis and assessment investigations.

Tables 8.3.1.8-1 through 8.3.1.8-6 list the favorable and potentially adverse conditions on which data are required for the resolution of Issue 1.8 and the performance measures, intermediate performance measures and

PERFORMANCE AND DESIGN ISSUES CALLING FOR DATA

PROGRAM

ANALYSIS AND ASSESSMENT

DATA COLLECTION

8.3.1.8-2

ISSUE 1.1
TOTAL SYSTEM PERFORMANCE
8 3 5 13

ISSUE 1.8
NRC SITING CRITERIA
8 3 5 17

ISSUE 1.9
HIGHER LEVEL FINDINGS POST-CLOSURE
8 3 5 18

ISSUE 1.11
CONFIGURATION OF UNDERGROUND FACILITIES (POSTCLOSURE)
8 3 2 2

PROGRAM 8.3.1.8
POSTCLOSURE TECTONICS

INVESTIGATION 8.3.1.8.1
VOLCANIC ACTIVITY

INVESTIGATION 8.3.1.8.2
TECTONIC EFFECTS ON WASTE PACKAGES

INVESTIGATION 8.3.1.8.3
TECTONIC EFFECTS ON HYDROLOGY

INVESTIGATION 8.3.1.8.4
TECTONIC EFFECTS ON GEOCHEMISTRY

(1) ALTERED PERCOLATION FLUX

(2) CHANGES IN WATER TABLE ELEVATION

(3) ALTERATIONS OF ROCK PROPERTIES

INVESTIGATION 8.3.1.8.5
POSTCLOSURE TECTONICS DATA COLLECTION AND ANALYSIS

INVESTIGATION 8.3.1.17.4
PRECLOSURE TECTONIC DATA COLLECTION AND ANALYSIS

INVESTIGATION 8.3.1.4.2
GEOLOGIC FRAMEWORK

INVESTIGATION 8.3.1.2.2
SITE UNSATURATED ZONE HYDROLOGIC SYSTEM

INVESTIGATION 8.3.1.2.3
SITE SATURATED ZONE HYDROLOGIC SYSTEM

INVESTIGATION 8.3.1.3.2
MINERALOGY, PETROLOGY AND ROCK CHEMISTRY

INVESTIGATION 8.3.1.3.3
MINERAL/GLASS STABILITY

INFORMATION NEED 8.3.2.2.3
UNDERGROUND FACILITY ORIENTATION AND LAYOUT

INVESTIGATION 8.3.1.2.1
REGIONAL HYDROLOGIC SYSTEM

CONSULTATION DRAFT

Figure 8.3.1.8-1. Relationships between the postclosure tectonics program, investigations, and performance design issues

Table 8.3.1.8-1(a). Investigation 8.3.1.8.1 - Studies to provide information required on direct releases resulting from volcanic activity

SCP section requesting parameter	Potentially adverse condition addressed (10 CFR 60 122(c)) (Section 8 3 5 17)	Favorable condition addressed (10 CFR 60 122(b)) (Section 8 3 5 17)	Initiating event	Performance measure	Tentative goal	Intermediate performance parameter	Goal	Performance parameter
8 3 5 13 (Issue 1 1, total system performance)	15	1	Volcanic eruption penetrates repository and causes direct releases to the accessible environment	EPPM ^a	<<1	Not applicable	-	Annual probability of volcanic eruption that penetrates the repository
8 3 5 17 (Issue 1 8, NRC siting criteria)								Effects of volcanic eruption penetrating repository, including area of repository disrupted
8 3 5 18 (Issue 1 9, higher level findings-postclosure)								

^aEPPM = expected partial performance measure (Section 8 3 5 13)

Table 8.3.1.8-1(b). Investigation 8.3.1.8.1 - Studies to provide information required on direct releases resulting from volcanic activity (page 1 of 2)

Performance parameter	Tentative parameter goal	Needed confidence	Characterization parameter	Testing basis			Investigations supplying data	Key studies or activities supplying data	
				Current estimate (range or bound)	Confidence in current estimate	Needed confidence in final values			
Annual probability of volcanic eruption that penetrates the repository	< 10 ⁻⁶ per yr	High	Location and timing of volcanic events	See Section 1 3 2 1 2	Moderate	High	8 3 1 8 5	8 3 1 8 5 1 1 - Volcanism drill-holes	
								8 3 1 8 5 1 2 - Geochronology studies	
			Evaluation of structural controls on volcanism	See Section 1 3 2.1	Low	Moderate	8 3 1 8 1	8 3 1 8 5	8 3 1 8 5 1 3 - Field geologic studies
									8 3 1 8 5 1 4 - Geochemistry of scoria sequences
									8 3 1 8 1 1 1 - Location and timing of volcanic events
									8 3 1 8 5 1 5 - Regional geochemical evolution of the DV-PRVZ
Presence of magma bodies in the vicinity of the site	See Section 1 3 2 1	Low	Moderate	8 3 1 17 4	8 3 1 17 4	8 3 1 17 4 12 1 - Evaluate tectonic processes and tectonic stability at the site			
						8 3 1 17 4 7 - Subsurface geometry of Quaternary faults at Yucca Mountain			
						8 3 1 8 5 2 1 - Evaluation of depth of curie temperature isotherm			
						8 3 1 8 5 2 3 - Heat flow at Yucca Mountain			
							8 3 1 17 4	8 3 1 8 4 1 2 - Monitor current seismicity	
								8 3 1 17 4 3 1 - Evaluate crustal structure and subsurface expression of Quaternary faults	

8.3.1.8-4

CONSULTATION DRAFT

Table 8.3.1.8-1(b). Investigation 8.3.1.8.1 - Studies to provide information required on direct releases resulting from volcanic activity (page 2 of 2)

Performance parameter	Tentative parameter goal	Needed confidence	Characterization parameter	Testing basis		Investigations supplying data	Key studies or activities supplying data
				Current estimate (range or bound)	Confidence in current estimate		
Effects of volcanic eruption penetrating repository, including area of repository disrupted, and confidence bounds of estimate	Show that < 0.1% of repository area is disrupted with a conditional probability of <0.1 of being exceeded in 10,000 yr, should such an intrusion occur	Moderate	Effects of Strombolian eruptions	< 0.05% of repository area disrupted	Moderate	Moderate	None planned (See Sections 1.3.2.1 and 1.5.1)
			Effects of hydrovolcanic eruptions	Data not available	Low	Moderate	8.3.1.8.5 8.3.1.8.5.1.3 - Field geologic studies

Table 8.3.1.8-2(a). Investigation 8.3.1.8.2 - Studies to provide information required on rupture of waste packages due to tectonic events

SCP section requesting parameter	Potentially adverse condition addressed (10 CFR 60 122(c)) (Section 8 3 5 17)	Favorable condition addressed (10 CFR 60 122(b)) (Section 8 3 5 17)	Initiating event	Performance measure	Tentative goal	Intermediate performance measure	Performance parameter
8 3 5 17 (Issue 1 8, NRC siting criteria)	15	1	Igneous intrusion penetrating repository resulting in failure of waste packages	Usable area is usable area adequate for 70,000 MTU of waste?	Probability < 0 1 in 1,000 yr that > 0 5% of waste packages will be ruptured by tectonic processes or events	Not applicable	Probability of igneous intrusion penetrating repository Effects of igneous intrusion penetrating repository
8 3 2 2 (Issue 1 11, configuration of underground facilities-postclosure)							
8 3 5 18 (Issue 1 9, higher level findings-postclosure)	11	1	Offset of one or more faults intersect waste packages and cause failure	Same as above	Same as above	Same as above	Number of waste packages affected by fault penetrating repository Probability of faulting with displacement over 5 cm in repository
	12 13 14	1	Ground motion causes spalling or failure and closes air gap around waste package	Same as above	Placement of waste packages in zones with rock properties that will not lead to failure during expected ground motions	Same as above	Expected ground motion at emplacement boreholes in 1,000-yr period
	11	1	Folding or distributed shear causes waste emplacement borehole deformation and results in waste package failure	Same as above	Probability < 0 1 in 1,000 yr that > 0 5% of waste packages will be ruptured by tectonic processes or events	Same as above	Rate of deformation due to folding or distributed shearing in repository horizon

8.3.1.8-6

CONSULTATION DRAFT

Table 8.3.1.8-2(b). Investigation 8.3.1.8.2 - Studies to provide information required on rupture of waste packages due to tectonic events (page 1 of 2)

Performance parameter	Tentative parameter goal	Needed confidence	Characterisation parameter	Testing basis			Investigations supplying data	Key studies or activities supplying data
				Current estimate (range or bound)	Confidence in current estimate	Needed confidence in final values		
Probability of igneous intrusion penetrating repository	Annual probability less than 10^{-5}	High	Characterisation parameters identical to Investigation 1.19.1	10^{-8} to 10^{-10}	Moderate	High	8.3.1.8.1	8.3.1.8.1.1.4 - Probability calculations and assessment
Effects of igneous intrusion penetrating repository	Less than 0.5% of waste packages disrupted	Low	Number of waste packages disrupted by intrusion	1 to 10	Moderate	Moderate	8.3.1.8.1	8.3.1.8.1.2.1 - Effects of Strombolian eruptions
							8.3.2.2.3	8.3.2.2.3 - Design concepts for the underground facility
Number of waste packages affected by fault penetrating repository	Less than 0.5% of waste packages intersected by a single fault with a 95% level of confidence	High	Width of Quaternary fault zones in and near site in which faulting exceeds 5 cm in a single event	< 5 m	Low	Moderate	8.3.1.17.4	8.3.1.17.4.2.2 - Conduct exploratory trenching in Midway Valley 8.3.1.17.4.6.2 - Evaluate age and recurrence of movement on suspected and known Quaternary faults
							8.3.1.4.2	8.3.1.4.2.2.1 - Geologic mapping of sonal features of Paintbrush Tuff
			8.3.1.4	8.3.1.4.2.3.1 - Development of 3-D geologic model of the site area				
			8.3.1.17.4	8.3.1.17.4.6.1 - Evaluate Quaternary geology and potential Quaternary faults at Yucca Mountain				
			Repository layout of waste packages and fault slip rates	See Section 6.2.6; < 0.01 mm/yr	Moderate	High	8.3.2.2.3	8.3.2.2.3 - Design concepts for the underground facility
							8.3.1.17.4	8.3.1.17.4.2.2 - Conduct exploratory trenching in Midway Valley 8.3.1.17.4.6.1 - Evaluate Quaternary geology and potential Quaternary faults at Yucca Mountain 8.3.1.17.4.6.2 - Evaluate age and recurrence of movement on suspected and known Quaternary faults

8.3.1.8-7

CONSULTATION DRAFT

Table 8.3.1.8-2(b). Investigation 8.3.1.8.2 - Studies to provide information required on rupture of waste packages due to tectonic events (page 2 of 2)

Performance parameter	Tentative parameter goal	Needed confidence	Characterisation parameter	Testing basis			Investigations supplying data	Key studies or activities supplying data
				Current estimate (range or bound)	Confidence in current estimate	Needed confidence in final values		
Probability of faulting with displacement over 5 cm in repository	Annual probability less than 10^{-4} of faulting with displacement over 5 cm	Moderate	Characteristics of faults that penetrate the repository with total offset > 10 m				8.3.1.17.4	8.3.1.4.2.2.1 - Geologic mapping of sonal features of Paintbrush Tuff 8.3.1.2.3.1 - Development of 3-D geologic model of the site area
			Density	See Section 1.3.2.2.2	Low	Moderate	8.3.1.4.2	8.3.1.17.4.6.1 - Evaluate Quaternary geology and potential Quaternary faults at Yucca Mountain
			Length	< 3000 m	Moderate	High		8.3.1.17.4.6.2 - Age and recurrence of movement on suspected and known Quaternary faults
			Total Offset	10-50 m	Moderate	High		
			Characteristics of Quaternary faults in and near site with slip rates > 0.001 mm/yr				8.3.1.17.4	8.3.1.17.4.6.1 - Evaluate Quaternary geology and potential Quaternary faults at Yucca Mountain 8.3.1.17.4.6.2 - Age and recurrence of movement on suspected and known Quaternary faults
			Location	See Figure 1-36	Moderate	High		8.3.1.17.4.12.1 - Evaluate tectonic processes and tectonic stability at the site
			Slip rate	< 0.01 mm/yr	Moderate	High		
			Length	< 35 km	Low	Moderate		
Expected ground motion at emplacement boreholes in 1,000-yr period	Probability of exceeding ground motion values < 0.1 in 1,000-yr	Moderate	Characterisation parameters identical to Investigation 8.3.1.17.3	Expected PGA ^a (10,000 yr return period) 0.5-0.7g	Low-moderate	Moderate	8.3.1.17.3	8.3.1.17.3.5.2 - Characterize ground motion from the controlling seismic events 8.3.1.17.3.6.2 - Evaluate ground motion probabilities
Rate of deformation due to folding or distributed shearing in repository horizon	Waste emplacement boreholes will be subject to < 0.005 shear strain in 1,000 yrs as a result of folding or deformation	Low	Nature and age of folding in the repository horizon	No detectable folding in 10 million yr	Moderate	High	8.3.1.4.2	8.3.1.4.2.2.1 - Geologic mapping of sonal features of Paintbrush Tuff
							8.3.1.4.3	8.3.1.4.2.3.1 - Development of 3-D geologic model of the site area
							8.3.1.17.4	8.3.1.17.4.12.1 - Evaluate tectonic processes and tectonic stability at the site
							8.3.1.8.2	8.3.1.8.2.1.2 - Calculation of the number of waste packages intersected by a fault

^aPGA = Peak Ground Acceleration.

Table 8.3.1.8-3(a). Investigation 8.3.1.8.3 - Studies to provide information required on changes in unsaturated and saturated zone hydrology due to tectonic events (Study 1; alteration of average percolation flux) (page 1 of 2)

SCP section requesting parameter	Potentially adverse condition addressed (10 CFR 60.122(c)) (Section 8.3.5.17)	Favorable condition addressed (10 CFR 60.122(b)) (Section 8.3.5.17)	Initiating event	Performance measure	Goal	Intermediate performance measure	Goal	Performance parameter
8.3.5.13 (Issue 1.1, total system performance)	3, 15	1, 8(i)	Volcanic eruption causes flows or other changes in topography that result in impoundment or diversion of drainage	EPPM ^a	<< 1	Radionuclide transport time through UZ, given fixed UZ thickness, rock hydrologic properties and geochemical properties	Tectonic processes and events will not adversely alter the average percolation flux at the top of the Topopah Spring welded unit by more than a factor of 2. The probability of exceeding the goal will be <0.1 in 10,000 yr	Annual probability of volcanic events within the controlled area Effects of a volcanic event on topography and flux rates
8.3.5.17 (Issue 1.8, NRC siting criteria)			Igneous intrusion, such as a sill, that could result in a significant change in average flux	Same as above	Same as above	Same as above	Same as above	Annual probability of significant igneous intrusion in the controlled area Effects of an igneous intrusion on flux rates
8.3.5.18 (Issue 1.9, higher level findings-postclosure)	3, 4, 11	1, 8(i)	Offset on fault creates surface impoundments, alters drainage, creates perched aquifers, or changes dip of tuff beds, thereby significantly changing average flux	Same as above	Same as above	Same as above	Same as above	Probability of offset > 2 m on a fault in the controlled area in 10,000 yr Probability of changing dip by > 2° in 10,000 yr by faulting Effect of faulting on flux rates

8.3.1.8-9

CONSULTATION DRAFT

Table 8.3.1.8-3(a). Investigation 8.3.1.8.3 - Studies to provide information required on changes in unsaturated and saturated zone hydrology due to tectonic events (Study 1; alteration of average percolation flux) (page 2 of 2)

SCP section requesting parameter	Potentially adverse condition addressed (10 CFR 60.122(c)) (Section 8.3.5.17)	Favorable condition addressed (10 CFR 60.122(b)) (Section 8.3.5.17)	Initiating event	Performance measure	Goal	Intermediate performance measure	Goal	Performance parameter
	3, 4, 11	1, 8(i)	Folding changes dip of tuff beds controlled area thereby significantly changing average flux	EPPM	<< 1	Same as above	Same as above	Probability of changing dip by > 2' in 10,000 yr by folding
	3, 4, 11, 16	1, 8(i)	Uplift or subsidence changes topography or drainage thereby significantly changing average flux	Same as above	Same as above	Same as above	Same as above	Probability of exceeding 30 m elevation change in 10,000 yr

^aEPPM = expected partial performance measure (see Section 8.3.5.13).

Table 8.3.1.8-3(b). Investigation 8.3.1.8.3 - Studies to provide information required on changes in unsaturated and saturated zone hydrology due to tectonic events (Study 1; alteration of average percolation flux) (page 1 of 2)

Performance parameter	Tentative parameter goal	Needed confidence	Characterization parameter	Testing basis		Investigations supplying data	Key studies or activities supplying data
				Current estimate (range or bound)	Confidence in current estimate		
Annual probability of volcanic events within the controlled area	$< 10^{-5}$ per yr	High	Probability calculation for volcanic events	10^{-7} to 10^{-8} per yr	Moderate	High	8.3.1.8.1 8.3.1.8.1.1.4 - Probability calculations and assessment
Effects of a volcanic event on topography and flux rates	Show topographic changes are not great enough to significantly affect flux	Low	Data on topographic changes caused by an eruption	See Section 1.5.1.2.2	Moderate	Moderate	8.3.1.8.1 8.3.1.8.1.2.1 - Effects of Strombolian eruptions 8.3.1.8.1.2.2 - Effects of hydrovolcanic eruptions
			Hydrologic model of flow in the unsaturated zone	See Section 3.9.3.2.1	Moderate	High	8.3.1.2.2 8.3.1.2.2.9 - Unsaturated zone flow and transport modeling
Annual probability of significant igneous intrusion in the controlled area	$< 10^{-5}$ per yr	High	Probability calculation for igneous events	10^{-7} to 10^{-8} per yr	Moderate	High	8.3.1.8.1 8.3.1.8.1.1.4 - Probability calculations and assessment
Effects of an igneous intrusion on flux rates	Show igneous intrusion will not significantly affect flux because of depth, location, and extent of intrusion	Low	Orientation and dimensions of possible intrusions at the site	\approx N.30.E; < 4 km x 0.3-4 m	Moderate	Moderate	No new activities planned
			Hydrologic model of flow in the unsaturated zone	See Section 3.9.3.2.1	Moderate	High	8.3.1.2.2 8.3.1.2.2.9 - Unsaturated zone flow and transport modeling
Probability of offset > 2 m on a fault in the controlled area in 10,000 yr	$< 10^{-1}$ per 10,000 yr	Moderate	Vertical slip rate and recurrence interval on Quaternary faults in and near the site	Slip rate < 0.01 mm per yr	Moderate	High	8.3.1.17.4 8.3.1.17.4.4.3 - Evaluate Stagecoach Road fault zone 8.3.1.17.4.6.2 - Evaluate age and recurrence of movement on suspected and known Quaternary faults

8.3.1.8-11

CONSULTATION DRAFT

Table 8.3.1.8-3(b). Investigation 8.3.1.8.3 - Studies to provide information required on changes in unsaturated and saturated zone hydrology due to tectonic events (Study 1; alteration of average percolation flux) (page 2 of 2)

Performance parameter	Tentative parameter goal	Needed confidence	Characterization parameter	Testing basis		Investigations supplying data	Key studies or activities supplying data	
				Current estimate (range or bound)	Confidence in current estimate			
Probability of changing dip by > 2° in 10,000 yr by faulting	< 10 ⁻⁴ per 10,000 yr	Low	Vertical slip rate on Quaternary faults in and near the site and rate of tilting	< 0.01 mm per yr	Moderate	High	8.3.1.17.4	8.3.1.17.4.6.1 - Evaluate Quaternary geology and potential Quaternary faults at Yucca Mountain 8.3.1.17.4.6.2 - Evaluate age and recurrence of movement on suspected and known Quaternary faults
							8.3.1.4.2	8.3.1.4.2.2.1 - Geologic mapping of sonal features of Paintbrush Tuff
							8.3.1.4.3	8.3.1.4.2.3.1 - Development of a 3-D geologic model of the site area
Effect of faulting on flux rates	Show faulting will not significantly affect flux because of low slip rate	Moderate	Hydrologic model of flow in the unsaturated zone	See Section 3.9.3.2.1	Moderate	High	8.3.1.2.2	8.3.1.2.2.9 - Unsaturated zone flow and transport modeling
Probability of changing dip by > 2° in 10,000 yr by folding	< 10 ⁻⁴ per 10,000 yr	Low	Rate of folding in the unsaturated zone section	No detectable folding in 10 million yr	Moderate	High	8.3.1.4.2	8.3.1.4.2.2.1 - Geologic mapping of sonal features of Paintbrush Tuff
							8.3.1.4.3	8.3.1.4.2.2.4 - Geologic mapping of the exploratory shaft and drifts
Probability of exceeding 30 m elevation change in 10,000 yr	< 10 ⁻⁴ per 10,000 yr	Low	Rate of uplift or subsidence at site	< 3 x 10 ⁻² mm per yr	Moderate	Moderate	8.3.1.17.4	8.3.1.4.2.3.1 - Development of a 3-D geologic model of the site area 8.3.1.17.4.9.2 - Evaluate extent of Quaternary uplift and subsidence at and near Yucca Mountain 8.3.1.17.4.10 - Geodetic leveling

8.3.1.8-12

CONSULTATION DRAFT

Table 8.3.1.8-4(a). Investigation 8.3.1.8.3 - Studies to provide information required on changes in unsaturated and saturated zone hydrology due to tectonic events (Study 2; changes in water table elevation) (page 1 of 2)

SCP section requesting parameter	Potentially adverse condition addressed (10 CFR 60 122(c)) (Section 8 3 5 17)	Favorable condition addressed (10 CFR 60 122(b)) (Section 8 3 5 17)	Initiating event	Performance measure	Goal	Intermediate performance measure	Goal	Performance parameter
8 3 5 13 (Issue 1 1, total system performance)	5, 15, 22, 23	1, 8(11)	Igneous intrusion causes barrier to flow or thermal effects that alter water-table level	EPPM ^a	<< 1	Radionuclide transport time through UZ, given fixed UZ rock hydrologic and geochemical properties	Water table will not rise to within 100 m of emplaced waste in 10,000 yr	Annual probability of a significant igneous intrusion within 0.5 km of controlled area boundary
8 3 5 17 (Issue 1 8, NRC siting criteria)							No discharge points created in the controlled area	Barrier-to-flow effects of igneous intrusions on water-table levels
8 3 5 18 (Issue 1 9, higher level findings - postclosure)							Perched aquifers will not be created within 100 m of emplaced waste	Thermal effects of igneous intrusions on water-table levels
	4, 5, 11, 22, 23	1, 8(11)	Episodic changes in strain in the rock mass due to faulting causes changes in water-table level	Same as above	Same as above	Same as above	The probability of exceeding the goals will be < 0.1 in 10,000 yr	Probability that strain-induced changes increased to potentiometric level to > 850 m mean sea level

8.3.1.8-13

CONSULTATION DRAFT

Table 8.3.1.8-4(a). Investigation 8.3.1.8.3 - Studies to provide information required on changes in unsaturated and saturated zone hydrology due to tectonic events (Study 2; changes in water table elevation) (page 2 of 2)

SCP section requesting parameter	Potentially adverse condition addressed (10 CFR 60.122(c)) (Section 8.3.5.17)	Favorable condition addressed (10 CFR 60.122(b)) (Section 8.3.5.17)	Initiating event	Performance measure	Goal	Intermediate performance measure	Goal	Performance parameter
	4, 5, 11, 22, 23	1, 8(ii)	Folding, uplift, or subsidence lowers repository with respect to water table	Same as above	Same as above	Same as above	Same as above	Probability that repository will be lowered by 100 m through action of folding, uplift, or subsidence in 10,000 yr
	4, 5, 11, 22, 23	1, 8(ii)	Offset on fault juxtaposes transmissive and nontransmissive units resulting in either the creation of a perched aquifer or a rise in the water table	Same as above	Same as above	Same as above	Same as above	Probability of total offsets > 2.0 m in 10,000 yr on a fault within controlled area boundary Effects of fault offset on water-table levels

^aEPPM = expected partial performance measure (see Section 8.3.5.13).

Table 8.3.1.8-4(b). Investigation 8.3.1.8.3 - Studies to provide information required on changes in unsaturated and saturated zone hydrology due to tectonic events (Study 2; changes in water-table elevation) (page 1 of 2)

Performance parameter	Tentative parameter goal	Needed confidence	Characterization parameter	Testing basis			Investigations supplying data	Key studies or activities supplying data
				Current estimate (range or bound)	Confidence in current estimate	Needed confidence in final values		
Annual probability of a significant igneous intrusion within 0.5 km of controlled area boundary	< 10 ⁻⁵ per yr	Moderate	Probability calculation for volcanic events	10 ⁻⁷ to 10 ⁻⁹ per yr	Moderate	High	8 3 1 8 1	8 3 1 8 1 1 4 Probability calculations and assessment
Barrier-to-flow effects of igneous intrusions on water table levels	Show water table will not rise to within 100 m of repository horizon in 10,000 yr	Low	Orientation and dimensions of possible intrusions at the site	Orientation N 20°-40°E Length 400-4000 m	Moderate	Moderate	8 3 1 17 4	8 3 1 17 4 12 1 - Evaluate tectonic processes and tectonic stability at the site
			Hydrologic model of saturated zone flow system	See Section 3 9 3 2 2	Moderate	High	8 3 1 2 3	8 3 1 2 3 3 1 Conceptualization of saturated zone flow models
Thermal effects of igneous intrusions on water table levels	Show water table will not rise to within 100 m of repository horizon in 10,000 yr	Low	Model thermal effects around a dike	400°C at 2 m distance after 40 days	Moderate	Moderate	8 3 1 8 1	8 3 1 8 1 2 1 - Effects of Strombolian eruptions 8 3 1 8 1 1 3 Presence of magma bodies in vicinity of site
			Hydrologic model of saturated zone flow system	See Section 3 9 3 2 2	Moderate	High	8 3 1 2 3	8 3 1 2 3 3 1 - Conceptualization of saturated zone flow models
Probability that strain induced changes increase potentiometric level to > 850 m MSL	< 10 ⁻⁵ per yr	Low	Strain rates and strain changes due to faulting	See Section 1 3 2 3	Low	Moderate	8 3 1 17 4	8 3 1 17 4 12 1 Evaluate tectonic processes and tectonic stability at the site
			Hydrologic model of saturated zone flow system	See Section 3 9 3 2 2	Moderate	High	8 3 1 2 3	8 3 1 2 3 3 1 Conceptualization of saturated zone flow models
Probability that repository will be lowered by 100 m through action of folding, uplift, or subsidence in 10,000 yr	< 10 ⁻⁴ per 10,000 yr	Low	Folding, uplift, and subsidence rates in site area	< 3 x 10 ⁻² mm per yr	Moderate	Moderate	8 3 1 17 4	8 3 1 17 4 9 2 Evaluate extent of Quaternary uplift and subsidence at and near Yucca Mountain 8 3 1 17 4 10 Geodetic leveling
							8 3 1 4 2	8 3 1 4 2 2 1 - Geologic mapping of zonal features of Paintbrush Tuff 8 3 1 4 2 2 4 Geologic mapping of exploratory shaft and drifts
							8 3 1 4 3	8 3 1 4 2 3 1 - Development of a 3 D geologic model of the site area

CONSULTATION DRAFT

8.3.1.8-15

Table 8.3.1.8-4(b). Investigation 8.3.1.8.3 - Studies to provide information required on changes in unsaturated and saturated zone hydrology due to tectonic events (Study 2; changes in water-table elevation) (page 2 of 2)

Performance parameter	Tentative parameter goal	Needed confidence	Characterization parameter	Testing basis		Investigations supplying data	Key studies or activities supplying data
				Current estimate (range or bound)	Confidence in current estimate		
Probability of total offsets > 2.0 m in 10,000 yr on a fault within controlled area boundary	< 10 ⁻¹ per 10,000 yr	Low	Slip rates on Quaternary faults in and near site	< 0.01 mm/yr	Moderate	High	8 3 1 17 4 8 3 1 17 4 4 3 Evaluate Stage coach Road fault zone 8 3 1 17 4 6 1 Evaluate Quaternary geology and potential Quaternary faults at Yucca Mountain 8 3 1 17 4 6 2 - Evaluate age and recurrence of movement on suspected and known Quaternary faults
Effects of fault offset on water table levels	Show water table will not rise to within 100 m of repository horizon in 10,000 yr	High	Orientation and length of faulting	N 25°E - N 25°W 10-20 km	Moderate	Moderate	8 3 1 17 3 8 3 1 17 3 1 - Relevant earthquake sources
			Hydrologic model of saturated zone flow system	See Section 3 9 3 2 1	Moderate	High	8 3 1 2 3 8 3 1 2 3 3 1 - Conceptualization of saturated zone flow models
			Hydrologic model of unsaturated flow system	See Section 3 9 3 2 1	Moderate	High	8 3 1 2 2 8 3 1 2 2 9 Unsaturated zone flow and transport modeling
			Evidence of higher water levels in Quaternary due to faulting	See Section 1 2 2 2 10	Low	Moderate	8 3 1 5 2 8 3 1 5 2 1 5 Studies of calcite and opaline silica vein deposits

8.3.1.8-16

CONSULTATION DRAFT

Table 8.3.1.8-5(a). Investigation 8.3.1.8.3 - Studies to provide information required on changes in unsaturated and saturated zone hydrology due to tectonic events (Study 3; alteration of rock properties along significant travel paths)

SCP section requesting parameter	Potentially adverse condition addressed (10 CFR 60.122(c)) (Section 8.3.5.17)	Favorable condition addressed (10 CFR 60.122(b)) (Section 8.3.5.17)	Initiating event	Performance measure	Goal	Intermediate performance measure	Goal	Performance parameter
8.3.5.13 (Issue 1.1, total system performance)	5, 15, 24	1, 8(i)	Igneous intrusion causes changes in hydrologic properties	EPPM ^a	<< 1	Radionuclide transport time through UZ, given fixed thickness of UZ	The localized flux along travel paths from the repository to the accessible environment will not be significantly increased for distances that are a significant part of the travel path over 10,000 yr	Annual probability of significant igneous intrusions within 0.5 km of controlled area boundary Effects of igneous intrusions on local fracture permeabilities and effective porosities
8.3.5.17 (Issue 1.8, NRC siting criteria)								
8.3.5.18 (Issue 1.9, higher level findings-postclosure)	4, 5, 11, 24	1, 8(i)	Episodic offset on faulting causes local changes in rock hydrologic properties, thereby destroying existing barriers to flow, creating barriers to flow, or creating new conduits for drainage	Same as above	Same as above	Same as above	Same as above	Annual probability of faulting events on Quaternary faults within 0.5 km of controlled area boundary Effects of fault motion on local fracture permeabilities and effective porosities
	4, 5, 11, 24	1, 8(i)	Changes in stress or strain in the controlled area resulting from episodic faulting, folding, or uplift causes changes in the hydrologic properties of the rock mass	Same as above	Same as above	Same as above	Same as above	Effects of changes of stress or strain on hydrologic properties of the rock mass

^aEPPM = expected partial performance measure (Section 8.3.5.13).

Table 8.3.1.8-5(b). Investigation 8.3.1.8.3 - Studies to provide information required on changes in unsaturated and saturated zone hydrology due to tectonic events (Study 3; alteration of rock properties along significant travel paths)

Performance parameter	Tentative parameter goal	Needed confidence	Characterisation parameter	Testing basis			Investigations supplying data	Key studies or activities supplying data
				Current estimate (range or bound)	Confidence in current estimate	Needed confidence in final values		
Annual probability of significant igneous intrusions within 0.5 km of controlled area boundary	$< 10^{-5}$ per yr	Moderate	Probability calculation for volcanic events	10^{-7} to 10^{-9} per yr	Moderate	High	8.3.1.8.1	8.3.1.8.1.1.4 - Probability calculations and assessment
Effects of igneous intrusions on local fracture permeabilities and effective porosities	Show no significant changes in rock hydrologic properties	Low	Evidence of change in rock properties around dikes in the region	No data available	Low	Moderate	8.3.1.8.5	8.3.1.8.5.2.2 - Chemical and physical changes around dikes
Annual probability of faulting events on Quaternary faults within 0.5 km of controlled area boundary	Show $< 10^{-4}$ per yr for each fault	High	Location of Quaternary faults in and near site	See Figure 1-36	Moderate	High	8.3.1.17.4	8.3.1.17.4.6.1 - Evaluate Quaternary geology and potential Quaternary faults at Yucca Mountain
			Slip rate and recurrence interval for Quaternary faults in and near site	Slip rate < 0.01 mm per yr	Moderate	High	8.3.1.17.4	8.3.1.17.4.6.2 - Evaluate age and recurrence of movement on suspected and known Quaternary faults
Effects of fault motion on local fracture permeabilities and effective porosities	Show change in fracture permeability is $< a$ factor of 2, and that fracture porosity increases	High	Evidence of episodic rock property changes along faults	See Section 1.3.2.2.2	Low	Moderate	8.3.1.4.2	8.3.1.4.2.2.3 - Borehole evaluation of faults and fractures 8.3.1.4.2.2.4 - Geologic mapping of exploratory shaft and drifts 8.3.1.3.2.1.3 - Fracture mineralogy
Effects of changes of stress or strain on hydrologic properties of the rock mass	Show changes in conductivity and porosity of rock mass are $< a$ factor of 2	Low	Potential stress and strain changes in the rock mass due to faulting or other tectonic processes	See Section 1.3.2.3	Low	Moderate	8.3.1.17.4	8.3.1.17.4.12.1 - Evaluate tectonic processes and tectonic stability at the site
			Hydrologic models of flow in the saturated and unsaturated zone	See Sections 3.9.2.1 and 3.9.3.2.2	Low	Moderate	8.3.1.2.2 8.3.1.2.3	8.3.1.2.2.9 - Unsaturated zone flow and transport modeling 8.3.1.2.3.3.1 - Conceptualization of saturated zone flow models

8.3.1.8-18

CONSULTATION DRAFT

Table 8.3.1.8-6(a). Investigation 8.3.1.8.4 - Studies to provide information required on changes in rock geochemical properties resulting from tectonic processes

SCP section requesting parameter	Potentially adverse condition addressed (10 CFR 60 122(c)) (Section 8 3 5 17)	Favorable condition addressed (10 CFR 60 122(b)) (Section 8 3 5 17)	Initiating event	Performance measure	Goal	Intermediate performance measure	Goal	Performance parameter
8 3 5 13 (Issue 1 1, total system performance)	8, 15, 24	1, 3	Igneous intrusion causes changes in rock geochemical properties	EPPM ^a	<< 1	Radionuclide transport time through UZ, given fixed thickness of UZ	For radionuclides with travel times less than 10,000 yr, the change in K _d s will not be more than a factor of 2 in 10,000 yr with a high level of confidence	Annual probability of igneous intrusions within 0.5 km of the controlled area boundary Effects of intrusions on local rock geochemical properties
8 3 5 17 (Issue 1 8, NRC siting criteria)								
8 3 5 18 (Issue 1 9, higher level findings-postclosure)	8, 11, 24	1, 3	Offset on a fault causes changes in movement of ground water that result in mineralogical changes along fault zone	Same as above	Same as above	Same as above	Same as above	Probability of movement and location of Quaternary faults in controlled area Degree of mineral changes in fault zone in 10,000 yr
	8, 11, 24	1, 3	Offset on a fault changes travel pathway to one with different geochemical properties	Same as above	Same as above	Same as above	Same as above	Probability of total offsets > 2.0 m in 10,000 yr on a fault within 0.5 km of controlled area boundary Effects of fault offset on travel pathway
	8, 11, 24	1, 3	Tectonic processes cause changes in ground-water table or movement that results in mineral changes in controlled area	Same as above	Same as above	Same as above	Same as above	Degree of mineral change in the controlled area resulting from changes in water-table level or flow paths in 10,000 yr

^aEPPM = expected partial performance measure (Section 8 3 5 13)

Table 8.3.1.8-6(b). Investigation 8.3.1.8.4 - Studies to provide information required on changes in rock geochemical properties resulting from tectonic processes (page 1 of 2)

Performance parameter	Tentative parameter goal	Needed confidence	Characterisation parameter	Testing basis		Investigations supplying data	Key studies or activities supplying data
				Current estimate (range or bound)	Confidence in current estimate		
Annual probability of significant igneous intrusions within 0.5 km of the controlled area boundary	$< 10^{-5}$ per yr	Moderate	Probability calculations for volcanic events	10^{-7} to 10^{-9} per yr	Moderate	High	8 3 1 8 1 8 3 1 8 1 1 4 - Probability calculations and assessment
Effects of intrusions on local rock geochemical properties	Show potential changes in mineralogy will not be extensive	Low	Evidence of change in geochemical properties around dikes in the region	Data not available	Low	Moderate	8 3 1 8 5 8 3 1 8 5 2 2 - Chemical and physical changes around dikes
Probability of movement within 2 km of surface and location of Quaternary faults in controlled area	$< 10^{-4}$ per yr for each fault	Moderate	Location of Quaternary faults in controlled area	See Figure 1-36	Moderate	High	8 3 1 17 4 8 3 1 17 4 6 1 - Evaluate Quaternary geology and potential Quaternary faults at Yucca Mountain
			Slip rate and recurrence intervals for Quaternary faults in the controlled area	< 0.01 mm per yr	Moderate	High	8 3 1 17 4 8 3 1 17 4 6 2 - Evaluate age and recurrence of movement on suspected and known Quaternary faults
Degree of mineralogic change in fault zone in 10,000 yr	Show adverse changes in mineralogy will not occur	Moderate	Nature and age of mineralogic changes on faults in the controlled area	See Section 1 3 2 3	Low	Moderate	8 3 1 4 2 8 3 1 4 2 3 - Borehole evaluation of faults and fractures 8 3 1 4 2 2 4 - Geologic mapping of shafts and drifts 8 3 1 3 2 1 3 - Fracture mineralogy 8 3 1 3 2 2 - History of mineralogic and geochemical alteration of Yucca Mountain
Probability of total offsets > 2.0 m in 10,000 yr on a fault within controlled area boundary	$< 10^{-1}$ per 10,000 yr	Moderate	Slip rates on Quaternary faults in and near site	< 0.01 mm per yr	Moderate	High	8 3 1 17 4 8 3 1 17 4 4 3 - Evaluate Stagecoach Road fault zone 8 3 1 17 4 6 2 - Evaluate age and recurrence of movement on suspected and known Quaternary faults

8.3.1.8-20

CONSULTATION DRAFT

Table 8.3.1.8-6(b). Investigation 8.3.1.8.4 - Studies to provide information required on changes in rock geochemical properties resulting from tectonic processes (page 2 of 2)

Performance parameter	Tentative parameter goal	Needed confidence	Characterization parameter	Testing basis			Investigations supplying data	Key studies or activities supplying data
				Current estimate (range or bound)	Confidence in current estimate	Needed confidence in final values		
Effects of fault offset on travel pathway	Show significant changes will not occur	Moderate	Hydrologic models of unsaturated and saturated zone flow	See Sections 3 9 3 2 1 and 3 9 3 2 2	Moderate	High	8 3 1 2 2 8 3 1 2.3	8 3 1 2 2 9 - Unsaturated zone flow and transport modeling 8 3 1 8 3 3 1 - Conceptualization of saturated zone flow models
Degree of mineralogic change in the controlled area resulting from changes in water-table level or flow paths in 10,000 yr	Show adverse changes in mineralogy will not occur	Low	Probability and magnitude of hydrologic changes	Data not available	Low	Moderate	8 3 1 8 3	8 3 1 8 3 2 2 - Assessment of the effects of igneous intrusion on water-table elevations 8 3 1 8 3 2 3 - Assessment of the effect of strain changes on water table elevation 8 3 1 8 3 2 4 - Assessment of the effect of folding, uplift, or subsidence on water-table elevation 8 3 1 8 3 2 6 - Assessment of the effect of faulting on water table elevation

8.3.1.8-21

CONSULTATION DRAFT

CONSULTATION DRAFT

performance parameters on which data are required by Issue 1.1 and Issue 1.11. Each table is linked to a specific performance or intermediate performance measure identified by Issue 1.1 or 1.11 and a specific post-closure tectonics program investigation. The first column in Part A of the tables identifies the performance or design issue that has requested information from the postclosure tectonics program. The second and third columns identify the potentially adverse and favorable conditions from Issue 1.8 that will be addressed by each initiating event.

The fourth column lists the initiating events identified by Issues 1.1 or 1.11 that are related to the performance measure or intermediate performance measure. Initiating events are tectonic events or processes that, if they should occur during the period of interest, could directly or indirectly lead to releases or adversely affect estimates of release at the accessible environment boundary. An example of an initiating event that could directly lead to releases is the penetration of the repository by a volcanic event. Most initiating events only indirectly affect estimates of release by potentially altering another parameter (such as average percolation flux rates) that, if changed, could adversely affect estimates of releases at the accessible environment boundary.

The fifth and sixth columns identify a performance measure and associated goal. Performance measures are high level measures of total system performance and are described in more detail in Section 8.3.5.13 (Issue 1.1) and Section 8.3.2.2 (Issue 1.11). The seventh and eighth columns describe an intermediate performance measure and associated goal that is related to a significant component of the radionuclide release calculation (e.g., average percolation flux rates) that could be altered by tectonic processes or events. The goal for the intermediate performance measure is not intended to indicate the expected value that will result from the analysis of the tectonics program or the value at which the site would fail to meet the system performance objective. Instead, the goal provides an estimate of when the initiating event may start to become significant in performance calculations and is intended to provide guidance to the tectonics program on the level of accuracy or precision required in the program's analyses. The intermediate performance measures and the scenario classes to which they belong are further described in Section 8.3.5.13 for Issue 1.1 or in Section 8.3.2.2 for Issue 1.11.

The final column in Part A describes the performance parameters that have been related by Issue 1.1 or Issue 1.11 to each initiating event. For each initiating event in the tectonics program there are usually two performance parameters. The first performance parameter provides the probability that the tectonic event described in the initiating event will occur during the period of interest. In many instances, estimating probabilities for a tectonic initiating event over 10,000 yr may be difficult. Evaluation of these probabilities are subject to considerable uncertainty, but these uncertainties are quantifiable using available data and judgment. The second performance parameter provides a description of the effects of the event on the concern described in the intermediate performance measure should such an event actually occur. The specific requirements of 10 CFR Part 960 are not explicitly addressed in the tables because it has been determined that no

CONSULTATION DRAFT

additional data are needed to make the higher level findings of 10 CFR Part 960 over that required to resolve Issue 1.1 (total system performance, Section 8.3.5.13) and Issue 1.8 (10 CFR Part 60, NRC siting criteria, Section 8.3.5.17). Detailed discussion of the 10 CFR Part 960 higher level findings can be found in Section 8.3.5.18 (higher level findings--postclosure).

Part A of Tables 8.3.1.8-1 through 8.3.1.8-6 basically repeats the information called for in Tables 8.3.5.13-9 through 8.3.5.13-16 in Issue 1.1 and the requirements of Issue 1.11 (Section 8.3.2.2). Part B of the tables indicates the data that will be used and the activities supplying the data necessary in addressing the performance parameters. The first column of Part B repeats the performance parameters from Part A to provide a link between the two parts of the table. The second column provides a tentative parameter goal for the performance parameter. Like the goals for intermediate performance measure, performance parameter goals are intended to provide guidance on the level of accuracy or precision required in addressing the performance parameter rather than indicating anticipated results or levels at which total system performance objectives would not be met. The third column presents a subjective judgment on the needed level of confidence and relative importance of the performance parameters in order to demonstrate that the goals for the performance measure and intermediate performance measure are satisfied. These judgments combine a consideration of the level of detail that can reasonably be achieved in addressing the parameter, the probability of the initiating event having a significant impact on the component of the system performance calculation being considered, and the probability of the initiating event occurring. The information in this column is intended to provide guidance to the data gathering activities on the relative amount of effort that should be expended in addressing each performance parameter.

The fourth column identifies the characterization parameters associated with each performance parameter. A characterization parameter is an item of information necessary to prepare the analysis called for in the performance parameter. Characterization parameters are frequently higher level parameters themselves in that data supplied by other activities must generally be compiled and synthesized to supply the necessary information. The fifth column provides the current estimate of the characterization parameter. These estimates are based on the data presented in Chapter 1, the references supporting Chapter 1, and the technical judgments based on these data. The sixth and seventh columns provide a judgment of the confidence in the current estimate of the characterization parameter and a judgment of the confidence needed at the end of site characterization in the characterization parameter. These two columns are intended to provide guidance to the data collecting activities on the amount of additional effort that is required to complete the program. The final two columns in Part B identify the investigation number, and number and short title of the specific studies or activities that are called upon to supply data to satisfy the characterization parameter.

The approach used in this program to satisfy the data needs listed in the performance parameters is to have one activity associated with each initiating event whose role is to prepare a report that provides an assessment of that event. The assessment will address the performance parameters associated with the initiating event and provide an overview of the probability of significant changes in existing conditions that could affect

CONSULTATION DRAFT

radionuclide release rates resulting from the tectonic process being considered. The report will provide the basis for deciding how the initiating event will be treated in repository performance assessment calculations. The data presented in Chapters 1 and 4 indicate that several of the initiating events (e.g., those related to uplift, folding, and geochemical changes) can be considered as non-credible in repository release calculations. In these cases, the reports prepared by this program will document this conclusion using existing data or bounding calculations, and little or no additional data will be gathered to directly address these initiating events.

Approach to satisfy performance and design requirements

Both the NRC technical criteria (10 CFR 60.122) and the DOE siting guidelines (10 CFR 960.4-2-7) require that prediction of future tectonic processes and events be determined from projections based on an examination of these processes and events during the Quaternary. The NNWSI Project, therefore, intends to base its analysis of performance measures on a projection of Quaternary rates of tectonic processes on geologic structures at and proximal to the site.

This program also supplies data for the resolution of Issue 1.8 (Section 8.3.5.17): analyses to determine the degree to which each of the favorable and potentially adverse conditions, if present, has been characterized and the extent to which it contributes to or detracts from isolation. Specific guidance on the scopes of these analyses is provided in 10 CFR 60.21(c)(1)(ii)(B): "For the purpose of determining the presence of the potentially adverse conditions, investigations shall extend from the surface to a depth sufficient to determine critical pathways for radionuclide migration from the underground facility to the accessible environment. Potentially adverse conditions shall be investigated outside of the controlled area if they affect isolation within the controlled area."

The data identified in the first four investigations will provide the additional detail necessary to accurately characterize the effects of tectonic processes operating at or near the site and to measure the rates at which they operated during the Quaternary. This information will then be used to provide the projection of future rates necessary to satisfy the performance parameters. Before each data gathering activity begins, the related performance parameters will be evaluated to determine if currently available data are sufficient to satisfy the parameter with the required level of confidence. If the performance parameter has been satisfied, then further studies will not be undertaken (Figure 8.3.1.8-2). If the parameter has not been satisfied, then the feasibility of planned or potential activities will be evaluated to determine if the activities will reasonably increase the level of confidence in the parameters that describe the process or not. If it is not feasible to increase the level of confidence, then no additional studies will be performed and the site performance will be evaluated on the basis of available data. The data gathering activities identified in the analysis and assessment investigations will be undertaken if they are found to provide the additional data or confidence necessary to resolve the performance parameter.

CONSULTATION DRAFT

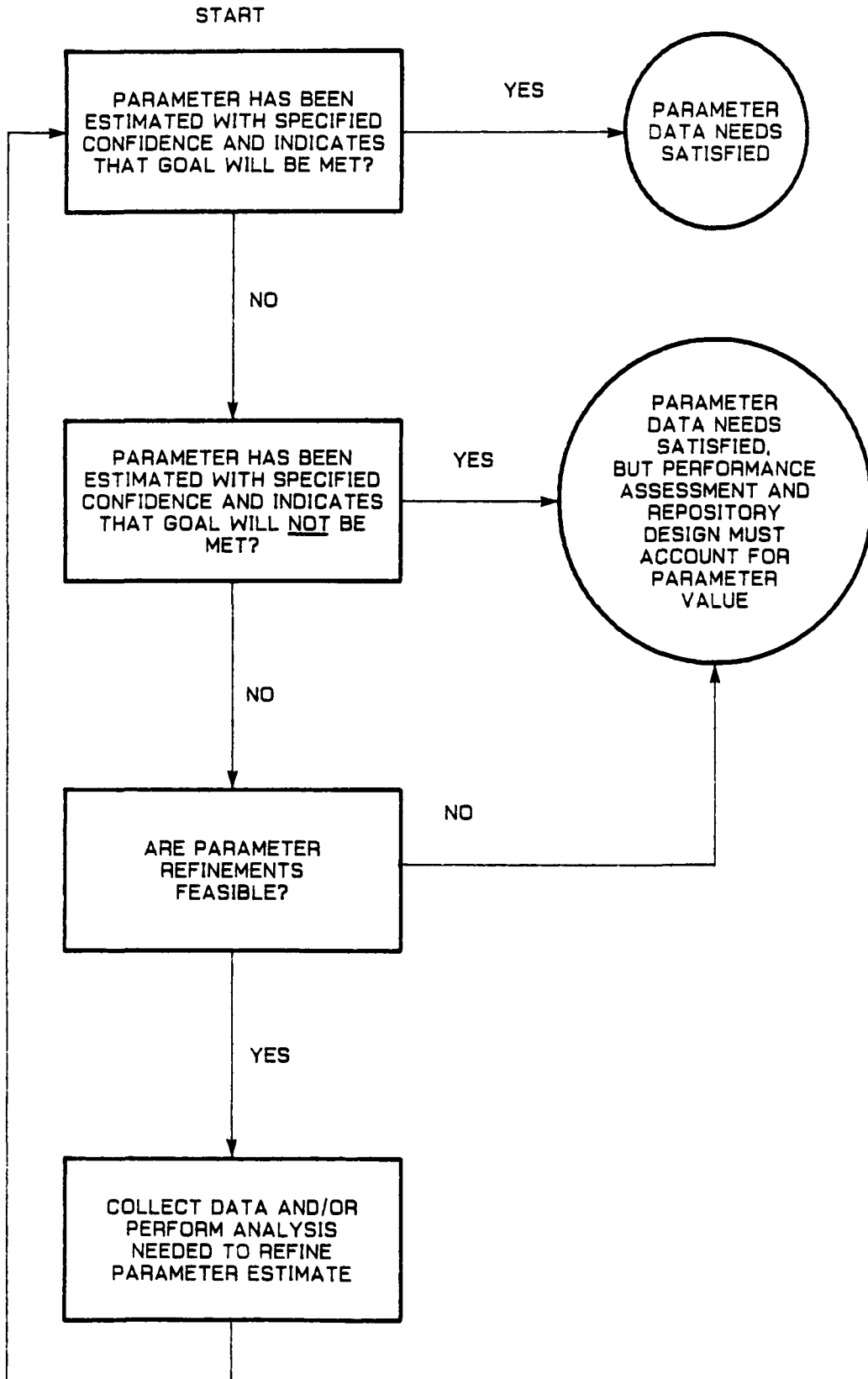

SCP83182

Figure 8.3.1.8-2. Parameter analysis

CONSULTATION DRAFT

Various data are used to make the projections of tectonic processes and events into the future, including earthquake observations, fault measurements, geologic mapping, drilling, gravity and magnetic surveys, and other geophysical data. Alternative interpretations of the data will be explored and evaluated with respect to implications for repository performance. These multiple interpretations will be refined to the extent necessary to establish the degree of confidence in the parameter characterization that is specified by the intermediate performance measure goals and performance parameter goals (Tables 8.3.1.8-1 through 8.3.1.8-6).

Five investigations have been identified under the postclosure tectonics program. The first four investigations are related to the six intermediate performance measures in Tables 8.3.1.8-1 through 8.3.1.8-6. The studies and activities connected with these investigations provide the analysis and interpretation necessary to evaluate the site against the performance parameter. These analysis activities also identify the type and level of detail of the data necessary for the resolution of the performance parameter. Because the analysis and interpretation activities for different performance parameters repeatedly call for the same type of data, data gathering activities are grouped separately under a fifth investigation that feeds data as required to the analysis activities associated with the performance and characterization parameters. The interrelationships among the investigations in this program are shown in Figure 8.3.1.8-1. Much of the data required to resolve this issue will be collected by activities associated with other programs. These activities and the data they are required to provide are identified in the investigation descriptions and in their accompanying logic diagrams.

Studies for Investigation 8.3.1.8.1 will provide the analyses to satisfy the performance parameters related to direct releases resulting from volcanic activity. These performance parameters address the initiating event related to the direct intrusion of magma into the repository or potential explosive episodes (hydrovolcanism) that may result from such intrusions which could directly result in releases to the accessible environment. As discussed in Sections 1.3 and 1.5, basaltic volcanism is considered the only credible scenario for igneous intrusion in the controlled area during the postclosure time period. Preliminary calculations of the probability of basaltic volcanism (Section 1.5.1.2.3) indicate that this type of igneous activity may fall into the range of unanticipated events (between 10^{-5} and 10^{-8} annual probability). The performance goal assumes that annual probabilities of occurrence for this type of event are independent of time (Poisson recurrence model) and sets for a goal that this type of event will remain unanticipated with a high level of confidence (10^{-6} annual probability or 99 percent level of confidence that the event will not occur in 10,000 yr). The strategy used in this investigation is to gather more refined data on the age, occurrence, and relation to geologic structure of basaltic volcanism in the site area and to use these data to calculate more detailed probabilistic assessments of the potential for basaltic volcanism intersecting the repository or occurring in the controlled area. The possibility that the occurrence of volcanism is not random over the region, but controlled by geologic structures or other factors will also be considered in the assessment. A second part of the strategy will be an assessment of the effects on a repository of Strombolian or hydrovolcanic eruptions that penetrate the repository.

CONSULTATION DRAFT

Investigation 8.3.1.8.2 will provide the analyses to resolve the performance measure related to the failure of waste packages due to tectonic events. Structural deformation resulting from tectonic processes such as faulting (including detachment faulting), uplift, subsidence, or folding could adversely affect the effective lifetime of the waste packages in containing the waste. If deformation was found to be significant enough that the requirements for waste package performance could not be met, the changes required in repository geometry may be such that the repository would no longer be able to accommodate the specified volume of waste (70,000 MTU). The goal (Table 8.3.1.8-2) for the performance measure is derived from the considerations discussed in Section 8.3.4.2. Section 8.3.4.2 sets design goals for rock-induced loads to the waste package. One goal states that less than 0.5% of the waste packages will be breached by anticipated tectonic processes and events that may occur during the first 1,000 yr. This level is designed to be compatible with the overall goal for waste package performance from all modes of failure of less than 5 percent in 300 yr and less than 20 percent in 1,000 yr. (Section 8.3.5.9). The level of confidence for the performance goal was set so that exceedance of the goal would be an unanticipated event.

The first initiating event considered under this intermediate performance measure is the possibility of igneous activity such as the intrusion of a dike or an explosive hydrovolcanic event which could lead to waste package failure (Table 8.3.1.8-2). The number of waste packages affected by a disruptive event such as a hydrovolcanic eruption has not been estimated. The performance parameter goal was set to have the penetration of the repository in 1,000 yr by igneous intrusions be an unanticipated event because waste package disruption scenarios only need to consider anticipated events.

The second initiating event considers the effect of fault displacement on waste package integrity. A value of 5 cm was selected as the performance parameter at which fault displacement becomes significant over a 1,000-yr period because at this value it is estimated that the 7.6-cm air gap around the waste package (Sections 6.2.6.2 and 7.3.1.3) would be substantially closed and any additional displacement might result in waste package failure.

The strategy for demonstrating that faulting will not lead to significant waste package failure in 1,000 yr will be to locate and characterize Quaternary faults in and proximal to the controlled area. Because these faults (such as Windy Wash and Paintbrush Canyon (Section 1.3.2.2.2)) have very low slip rates, it is anticipated that the demonstration can be made that the occurrence of 5 cm of displacement in 1,000 yr on even these longer, more significant faults is a very low probability event. The characteristics of the known Quaternary faults in the area will be compared to those of the faults that penetrate the repository block to demonstrate that these smaller faults are much less likely to support a slip rate comparable to the larger faults in the area. A second part of the strategy will be to estimate the number of waste packages a throughgoing fault would intersect in the repository. Using the formula of Link et al. (1982) to estimate the hazard posed by faulting, a randomly oriented fault would intersect about ten waste packages out of an inventory of 18,000 waste packages in a 510 ha repository. This type of analysis will be used to demonstrate that significant displacement would have to occur on several faults to create failures on more than 0.5 percent of the waste package inventory.

CONSULTATION DRAFT

The third initiating event considers the possibility that high rates of folding operating over a 1,000-yr period could result in sufficient waste-emplacement borehole deformation to lead to waste package failure. The performance parameter goal was selected so that, if the goal is met, then bending of waste emplacement boreholes by folding or deformation due to distributed shear of more than 5 cm will not be a credible event (less than 10^{-8} annual probability). The value of 5 cm for the goal for borehole deformation was also selected on the basis of a substantially reduced air gap around the waste package. The strategy for demonstrating compliance with the performance parameter goal will be to demonstrate the absence of significant folding in the repository horizon during the last 10 million yr.

Regional uplift and subsidence are not considered credible processes that could lead to waste package failure. The only conceivable mechanism by which uplift could lead to waste package failure is for extreme uplift rates to occur, which could lead to the exposure of waste packages to erosional processes. This initiating event is considered separately in Investigation 8.3.1.6.3.

Investigation 8.3.1.8.3 addresses the effects tectonic processes may have on hydrologic characteristics in the controlled area. A set of three intermediate performance measures have been identified as the significant hydrologic factors that could be adversely affected by tectonic processes and events. The three intermediate performance measures are alteration of average percolation flux, changes in water-table elevation, and alteration of rock properties along significant potential travel paths (Tables 8.3.1.8-3 to 8.3.1.8-5 and Section 8.3.5.13).

The initiating events identified for the intermediate performance measure that addresses the alteration of average percolation flux are concerned with tectonic processes that could alter flux rates such as (1) the creation of impoundments due to volcanic flows or the formation of fault scarps, (2) the diversion of drainage due to volcanic activity, faulting, uplift, or subsidence, (3) the creation of perched aquifers above the repository due to faulting, (4) the creation of impermeable zones such as the injection of a sill, and (5) a change in dip of the repository rock due to faulting or folding. The basic strategy in addressing this intermediate performance measure will be to measure the Quaternary rate of igneous activity and tectonic deformation due to faulting, folding, uplift, and subsidence in the repository area and demonstrate that these rates are low enough that the performance parameter goal would not be exceeded in a 10,000-yr period.

The intermediate performance measure concerned with changes in water table elevation (Table 8.3.1.8-4) considers the possibility that tectonic events or processes could result in rises in the water table, changes in the potentiometric level of confined aquifers, or the creation of perched aquifers. Such changes could result in the shortening of the ground-water travel pathway in the unsaturated zone and altered radionuclide release rates to the accessible environment. Changes in water-table elevation may also affect hydraulic gradients and the location of discharge points. The distance from the repository horizon to the water table is currently about 250 m. The intermediate performance measure goal was set at a distance of greater than 100 m because it is estimated that the reduction in unsaturated zone release rates would become significant at this point.

CONSULTATION DRAFT

The effects of tectonic initiating events considered as possible causes for these changes in the length of the unsaturated zone pathway in Table 8.3.1.8-4 include (1) the creation of barriers to ground-water flow as a result of the formation of igneous dikes, (2) offsets that juxtapose units with differing hydrologic properties due to movement on a fault, (3) the change in elevation of the repository with respect to the water table due to folding or subsidence, and (4) the change in water-table elevation or potentiometric level that might result from strain changes through the faulting cycle.

The intermediate performance measure addressing the alteration of rock properties along significant potential travel paths is concerned with possible changes in rock properties due to tectonic processes that could result in changes in the hydrologic flow properties of the rocks in the controlled area. The effects of initiating events considered are (1) changes in rock properties due to an igneous intrusion, (2) change in rock properties along a fault due to fault movement that results in the creation or destruction of barriers to lateral flow or the creation of conduits of increased vertical flow, and (3) changes in the hydrologic properties of the rock mass due to episodic changes in strain due to faulting or folding (Table 8.3.1.8-5). This intermediate performance measure will also consider the effects that changes in rock properties could have on the movement of gaseous decay products in the unsaturated zone. The strategy for evaluating the magnitude of such changes will be to estimate the rate of tectonic activity in the area and estimate the impact of tectonic processes through hydrologic modeling.

Investigation 8.3.1.8.4 addresses the possibility that geochemical characteristics could be changed in the controlled area as a result of tectonic processes and events. This investigation addresses the concerns of the intermediate performance measure that addresses the possible changes in rock geochemical properties or ground-water chemistry resulting from tectonic processes and events (Table 8.3.1.8-6). The goal for this intermediate performance measure was set so that tectonic processes would not adversely affect the radionuclide release rate due to changes in the distribution coefficient (K_d) of the rock by more than a factor of 2 in 10,000 yr for those radionuclides with expected travel times of less than 10,000 yr with a high level of confidence. The effects of initiating events that are considered for this intermediate performance measure are (1) alteration of the country rock caused by an igneous intrusion, (2) changes in the mineralogy along a fault zone due to changes in ground water flow paths caused by faulting, (3) changes in travel paths due to faulting, and (4) mineralogic changes caused by fluctuations in water level due to tectonic events. The principal strategy in addressing this intermediate performance measure will be to investigate the nature and extent of mineralogic changes that have occurred in the past around dikes and faults in the area around the site.

The studies and activities that provide the data for the analyses of the intermediate performance measures are collected under Investigation 8.3.1.8.5. The data-gathering studies and activities are aggregated separately from the investigations addressing the intermediate performance measures because each of the intermediate performance measures tends to call on the same data to analyze its initiating events. The separation of data-analysis activities from data-gathering activities by placing them in

CONSULTATION DRAFT

different investigations is believed to improve and clarify the logic flow in the investigations related to the analysis of the intermediate performance measures and to identify more clearly the nature and level of detail of data that must be collected. The activities collected under Investigation 8.3.1.8.5 for this tectonics program are few because most of the data necessary for the resolving of the intermediate performance measures are supplied by activities in other programs. The data that are being supplied by activities in other programs are identified in Tables 8.3.1.8-1 to 8.3.1.8-6 and in the investigation descriptions.

Interrelationships of postclosure tectonics investigations

The interrelationship among issues, programs, investigations, favorable conditions, and potentially adverse conditions is shown in Tables 8.3.1.8-1 to 8.3.1.8-6, Figure 8.3.1.8-1, and in the logic diagrams accompanying the investigation descriptions.

The assessment of potential igneous activity in Investigation 8.3.1.8.1 will require an improved data base on the nature and rate of past activity in order to prepare a probabilistic calculation on the possibility of future igneous activity. The assessment will also include a consideration of possible structural controls on igneous activity and an evaluation of the possibility of magma sources underlying the site. A second study will evaluate the disruptive effects of Strombolian and hydrovolcanic eruptions should they occur at the repository.

Investigation 8.3.1.8.2 is composed of one study that will assess the likelihood and effects of each of the four initiating events on waste package integrity. Data for the assessment of waste package rupture due to igneous activity will come from Investigation 8.3.1.8.1. The assessment of waste package rupture due to faulting will use (1) data on the number of waste packages that could be intersected by a throughgoing fault and (2) data on the slip rate, recurrence interval and displacement of individual events, length, sense of movement, and width of zone of Quaternary deformation for the north-trending normal faults found in and near the controlled area from Investigations 8.3.1.17.4 and 8.3.1.4.2.

The performance parameter goals for folding indicate levels of significance that are so high in relation to natural rates that existing data and data from Investigation 8.3.1.4.2 are sufficient to make an assessment. Only minor studies to gather additional data on folding in the region are planned.

Investigation 8.3.1.8.3 will use data on the nature and rates of igneous activity, faulting, folding, uplift, and subsidence collected by the investigations listed in Tables 8.3.1.8-3 to 8.3.1.8-6 to perform an assessment of the amount of change that could be expected over the next 10,000 yr for the three hydrologic concerns discussed in the intermediate performance measures. In each instance, this assessment will have two parts and will be an iterative process. The first part will be an estimation of the probability of occurrence of tectonic processes that could affect hydrologic properties and a characterization of the type of changes that could occur and the volume of rock affected. The second part of the assessment will be hydrologic modeling of potentially significant changes in model parameters due to tectonic

CONSULTATION DRAFT

processes to determine the expected amount of change in the hydrologic intermediate performance measures. This investigation therefore supplies the interface point needed for the integration of data between the geohydrology and postclosure tectonics program staff.

Investigation 8.3.1.8.4 will provide the analysis necessary to address the intermediate performance measure concerning changes in rock geochemical properties resulting from tectonic processes. The data necessary to perform the analysis will be supplied by activities in Investigations 8.3.1.17.4, 8.3.1.2.2, 8.3.1.2.3, and 8.3.1.4.2 (Table 8.3.1.8-6). The analysis will use data on mineral changes around dikes and faults in the area surrounding the site to project the amount of expected change in the next 10,000 yr. Other studies and activities will evaluate the probability of the initiating events and evaluate the potential mineral changes that could result from the occurrence of those events.

Investigation 8.3.1.8.5 will house the data-gathering studies and activities that are called for by the analysis activities. The studies contained in this investigation are related to the probability and effects of volcanic events and folding in region surrounding the repository. All other required data will be collected by investigations related to other programs.

8.3.1.8.1 Investigation: Studies to provide information required on direct releases resulting from volcanic activity

Technical basis for obtaining the information

Link to the technical data chapters and applicable support documents

The following sections of the SCP data chapters and support documents provide a technical summary of existing data relevant to this investigation:

<u>SCP section</u>	<u>Subject</u>
1.3.2.1	Volcanic history
1.5.1	Volcanism
1.8.1.3.1, 1.8.1.3.2	Significant results (structural geology and tectonics), discussion of significant results
1.8.1.5.1	Significant results (long-term regional stability)

Parameters

The following performance parameters (Table 8.3.1.8-1 and Section 8.3.5.13) will be measured or calculated as a result of the studies planned to satisfy this investigation:

1. Annual probability of a volcanic eruption that penetrates the repository.

CONSULTATION DRAFT

2. Effects of a volcanic eruption penetrating the repository including area of repository disrupted and confidence bounds of estimate.

Purpose and objectives of the investigation

The purpose of this investigation is to provide the data required for an assessment of repository performance with respect to the possibility of direct releases resulting from volcanic events. The two performance parameters for this investigation have been identified by Issue 1.1 (Section 8.3.5.13 and Table 8.3.1.8-1). The evaluation of these two performance parameters is the subject of the two studies in this investigation (Figure 8.3.1.8-3). The two studies in this investigation will also supply the data required by Issue 1.8 (Section 8.3.5.17) to address the favorable and potentially adverse conditions of 10 CFR 60.122 listed in Table 8.3.1.8-1. Investigations 8.3.1.8.2 through 8.3.1.8.4 will also use the results of this investigation in their analyses of other intermediate performance measures.

Technical rationale for the investigation

This investigation considers the single initiating event of a volcanic eruption penetrating the repository and resulting in direct releases to the atmosphere or land surface. As discussed in Sections 1.3.2.1 and 1.5.1, basaltic volcanism is considered to be the only credible type of activity to have a possibility of occurrence in the next 10,000 yr. Releases could occur as the result of a dike that feeds a volcanic vent intersecting the repository and entraining some waste. The waste could be ejected in a Strombolian eruption as pyroclasts and incorporated in an ash fall and cinder cone. As an alternative, if the ascending magma intersects a body of ground water, a hydrovolcanic explosion could occur at depths great enough to cause disruption of the repository. This hydrovolcanic type of eruption might result in the ejection of waste fragments as a result of the explosions from a tuff-ring or maar volcano. Hydrovolcanic eruptions may change in time to a Strombolian eruption resulting in the formation of a cinder cone.

Study 8.3.1.8.1.1 correlates to the first performance parameter listed in the previous section. This study will analyze the data collected by the program and estimate the probability of a volcanic event intersecting the repository. The logic flow for the four activities contained in the study is shown in Figure 8.3.1.8-3. The probability calculations will be refined versions of the estimates presented in Section 1.5.1.2 and will assume that the occurrence of basaltic volcanism in the region is independent of time and location (Poisson recurrence model). It is possible that the occurrence of volcanism is not actually a completely random process but that the location of volcanic vents and the probability of their occurrence can be affected by regional structural trends, local structures, and even topography. The influence of regional structural trends was factored into the area ratio (area of repository/area to which volcanic event rate applies) of the probability calculations (Section 1.5.1.2.3). The possibility of local structural controls will be assessed by evaluating the location of late Cenozoic basaltic vents in relation to known structures and aeromagnetic, gravity, and seismic data. The results of these analyses will be incorporated into the final volcanic probability assessment as appropriate. Geophysical evidence will also be evaluated for indications that magma bodies

INTERMEDIATE PERFORMANCE MEASURE

DATA ANALYSIS AND ASSESSMENT

DATA REQUIRED

KEY DATA GATHERING ACTIVITIES

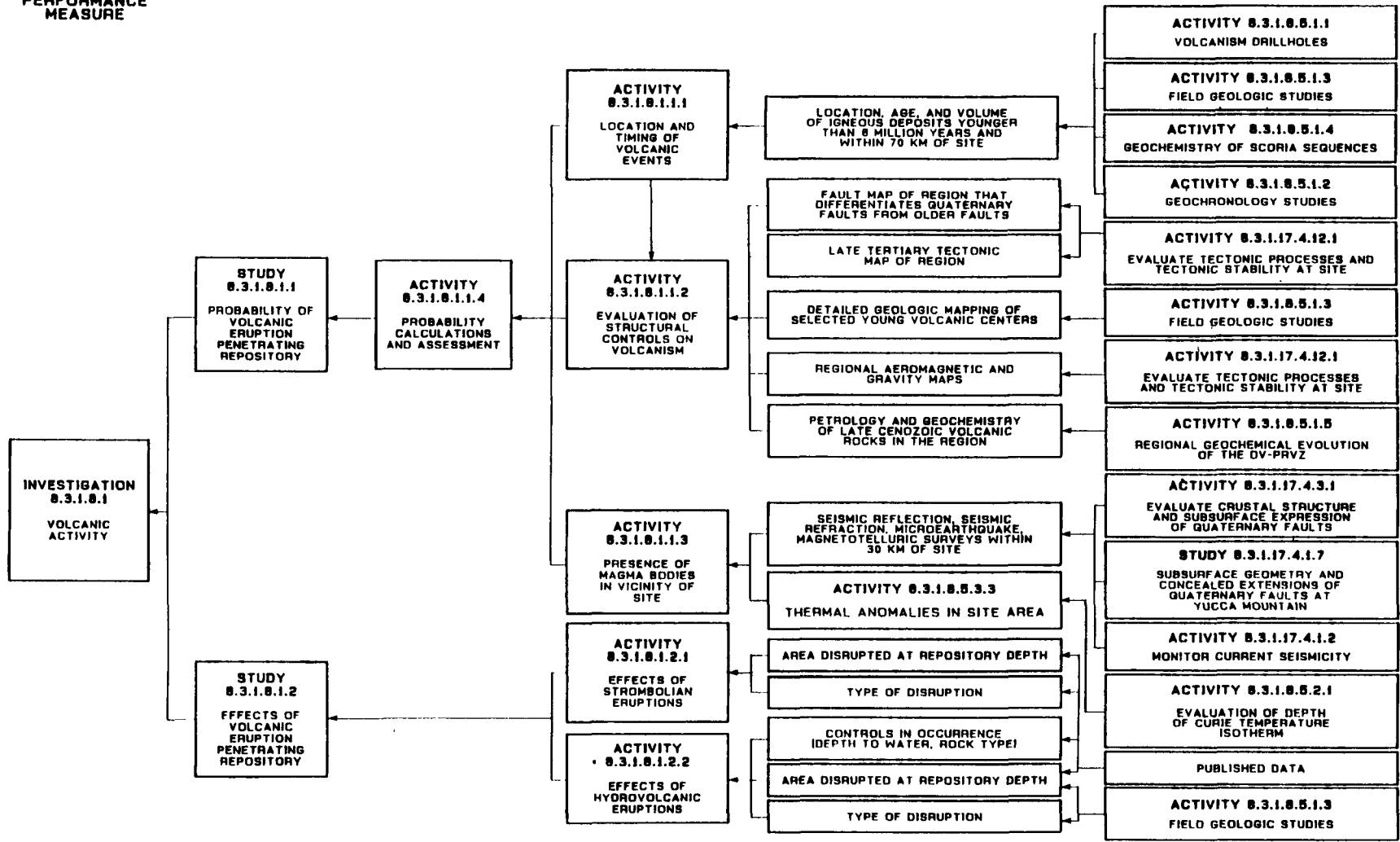

83185A

Figure 8.3.1.8-3. Logic diagram for Investigation 8.3.1.8.1 (volcanic activity).

CONSULTATION DRAFT

may be present in the vicinity of the site. The evidence for the presence or absence of magma bodies will also be factored into the probabilistic estimates.

Study 8.3.1.8.1.2 correlates with the second performance parameter listed in the previous section and will consider the effects a basaltic eruption could have on repository performance if such an event should occur. Two types of eruptions have been found to be characteristic of past activity in the region: Strombolian and hydrovolcanic (Section 1.3.2.1.2 and 1.5.1.2). Sufficient data have been collected on the effects of Strombolian eruptions for an analysis of repository performance so no additional field data gathering is planned. Additional data are needed on the effects of and controls of hydrovolcanic eruptions. This study will integrate current and newly acquired data into a format that can be used for repository performance assessment.

8.3.1.8.1.1 Study: Probability of a volcanic eruption penetrating the repository

The purpose of this study is to assess the probability of future volcanic activity with respect to siting of a repository for storage of high-level radioactive waste at Yucca Mountain. The probability assessment will be completed through a combination of studies and the results of these studies will be compared for consistency (Crowe et al., 1983a). The probability that volcanic activity could intersect the repository will be estimated from the analysis of a variety of data on the location and timing of volcanic events during the last 4 to 8 million yr, magma generation rates, structural controls on the location of volcanic activity, and geophysical data on the locations of potential magma bodies that could be the sources for future events.

8.3.1.8.1.1.1 Activity: Location and timing of volcanic events

Objectives

The objective of this activity is to synthesize the data collected by other activities (Figure 8.3.1.8-3) on the dating, location, and volume of late Cenozoic volcanic events in the region surrounding the site. These additional data will be used by Activity 8.3.1.8.1.4 to produce revised probability estimates of the disruption of the repository by volcanic events.

Parameters

The parameters for this activity are the location, age, and volume of volcanic deposits within 70 km of the site and younger than 8 million yr.

CONSULTATION DRAFT

Description

Data from the literature, previously completed studies and the planned studies in Investigation 8.3.1.8.5 will be compiled and synthesized to produce maps showing the age, location of vents, and distribution and volume of lava and pyroclastic deposits erupted from the vents. The resulting maps will be interpreted to determine eruptive patterns of volcanic activity during the last 8 million years. Magma volumes will be calculated as dense rock equivalents versus time and vent counts will be calculated to provide data for forecasting future rates of volcanic activity for probability calculations (Crowe et al., 1982). The data and analyses produced by this activity will be used to calculate the probability of volcanic eruptions (Activity 8.3.1.8.1.1.4) and in the evaluation of possible structural controls on volcanic activity (Activity 8.3.1.8.1.1.2).

Methods and technical procedures

Activity 8.3.1.8.1.1.1 will only synthesize and compile data collected by other activities and will use the methods and technical procedures given in the following table.

Method	Number	Technical procedure	
		Title	Date
Analysis of data	TWS-INC-WP-12, R0	Volcanic hazard investigations work plan	24 Nov 82

8.3.1.8.1.1.2 Activity: Evaluation of the structural controls of basaltic volcanic activity

Objectives

The time-space distribution of basaltic volcanic activity may not be completely random across the site area. This activity will investigate the time-space patterns of past volcanic activity in the Yucca Mountain region and the possible structural controls of volcanic centers and potential future volcanic centers at and adjacent to Yucca Mountain. Statistical evaluation of geophysical data will be undertaken to assess the significance of possible local and regional structures on the area ratio of the probability calculation.

Parameters

The data gathered from other activities that are needed for this work are

1. A tectonic model for the Yucca Mountain region (including fault map of the region that differentiates Quaternary faults from older

CONSULTATION DRAFT

faults and a late Cenozoic tectonic map of the region; Activity 8.3.1.17.4.12.2: evaluate tectonic models).

2. Aeromagnetic, gravity and seismic data for the Yucca Mountain region.
3. Field mapping of young volcanic centers (< 4 million years old) in the Yucca Mountain region (Activity 8.3.1.8.5.1.3: field geologic studies).
4. Geochronology measurements for young volcanic rocks (< 4.0 million years old; Activity 8.3.1.8.5.1.2: geochronology studies).
5. Petrologic cycles of volcanic rocks in the Yucca Mountain area (< 8.0 million years old) and from other basaltic volcanic fields of the southern Great Basin (Activity 8.3.1.8.5.1.5: petrologic cycles of basaltic volcanic fields).

The data to be gathered by this activity are

1. Cluster analysis of aeromagnetic data.

Description

The time-space patterns of basaltic volcanic activity will be examined for the Yucca Mountain region. Current data support a progressive south-westerly stepping of areas of volcanic activity through time. The youngest activity is concentrated in the Crater Flat area at, and northeast of, the intersection of the Bare Mountain fault system with the Mine Mountain-Spotted Range structural zone. Preliminary evidence suggests the Bare Mountain fault is no longer a structural boundary for the localization of sites of basaltic activity. This interpretation implies that future volcanic activity should occur southwest of the Crater Flat area, between the Bare Mountain and the Death Valley fault zones and that the peak of basaltic volcanic activity has passed from the Crater Flat area. Geologic and geophysical evidence will be evaluated for this volcanic/tectonic model and the model will be integrated with tectonic models developed in Investigation 8.3.1.17.4.

Three important lines of evidence will be evaluated for the volcanic/tectonic structural studies. First, plots of magma volume versus time for volcanic activity of the Yucca Mountain area show declining rates of magma production through time. This interpretation must be tested using refined data for the age of volcanic activity from Activity 8.3.1.8.5.1.2 (geochronology studies), and for the volume of volcanic activity from Activity 8.3.1.8.5.1.3 (field geologic studies). Second, geochemistry studies of the Crater Flat area (Vaniman et al., 1982; Crowe et al., 1983b, 1986) show distinct petrologic trends through time. The oldest basalts of the Crater Flat area are hypersthene-normative hawaiite and the youngest basalts are nepheline-normative hawaiite or basanite. These same trends have been observed, but not documented in detail, at other basaltic volcanic fields of the Basin and Range province (Lunar Crater and Cima volcanic fields). Further work is required to determine if the transition to nepheline-normative basalt is indicative of the waning or termination of

CONSULTATION DRAFT

volcanic activity at a field. Third, the transition from hypersthene- to nepheline-normative basalt in the Crater Flat area is accompanied by a decrease in the volume of eruptive products and an increase in the frequency of eruptions. This observation, if valid, may affect assumptions used for forecasting future rates of volcanic activity. It must be tested by studying time variations in the petrology and volume of basaltic activity at other volcanic fields in the Yucca Mountain vicinity.

The three topics, magma volume/time, petrologic patterns through time, and the decreased volume/increased eruptive frequency through time all are important observations that affect assumptions used for calculating the probability of future volcanic activity at Yucca Mountain. It is important that these concepts be tested at other volcanic fields in the region, particularly fields that have a more voluminous record of eruptive activity, to test the implications of conclusions for the Yucca Mountain area (Activity 8.3.1.8.5.1.5).

The second topic to be examined for this activity is the local structural controls for sites of volcanic activity in the Yucca Mountain area. Cluster analyses routines will be used to assess spatial patterns of aeromagnetic data in the Yucca Mountain area. Identified patterns will be correlated with known structures in the Yucca Mountain area and the location of volcanic centers to identify what structural features control the location of volcanic vents. This information will be used to test for the presence of potential structural features in the Yucca Mountain exploration block that could provide pathways for the localization of future volcanic activity. The results of this analysis will be factored into the volcanic probability calculations (Activity 8.3.1.8.1.1.4).

Methods and technical procedures

Activity 8.3.1.8.1.1.2 will only synthesize and compile data collected by other activities and will use the methods and technical procedures given in the following table.

Method	Technical procedure		Date
	Number	Title	
Analysis of data	TWS-INC-WP-12, RO	Volcanic hazard investigations work plan	24 Nov 82
Cluster analysis routines	TBD ^a	TBD	FY 1988

^aTBD = to be determined.

CONSULTATION DRAFT

8.3.1.8.1.1.3 Activity: Presence of magma bodies in the vicinity of the site

Objectives

The objective of this activity is to review geophysical data collected in the vicinity of the site to assess whether any indications of midcrustal magma bodies are present that might be the source for future volcanic events.

Parameters

The parameters for this activity are seismic refraction, seismic reflection, Curie temperature isotherm, heat flow, gravity, magnetotelluric and microearthquake data collected within 30 km of the site.

Description

The geophysical and microearthquake data collected at the site and in surrounding areas, such as Crater Flat, by Studies 8.3.1.17.4.1, 8.3.1.17.4.3, and 8.3.1.17.4.7 will be analyzed to determine if there are indications of a magma body in close proximity to the site. The magma bodies that would be associated with the Strombolian eruptions that have occurred in the region during the Quaternary probably occur at depths of 20 km or more. Magma bodies of this type have been found in Death Valley (de Voogd et al., 1986) and the Rio Grande rift (Brown et al., 1979; Jiracek et al., 1979; Rinehart et al., 1979) at depths of about 20 km using geophysical and micro-earthquake techniques. The regional depth to the Curie temperature isotherm and heat flow data will also be investigated for indications of possible temperature anomalies related to magmatism. This activity will consist of an interpretation of data collected by other activities only. No new data will be collected for this activity.

Methods and technical procedures

The methods and technical procedures for this activity are given in the following table.

Method	Technical procedure		
	Number	Title	Date
Analysis of data	TWS-INC-WP-12, R0	Volcanic hazard investigations work plan	24 Nov 82
Analysis of geophysical data	TBD ^a	TBD	TBD

^aTBD = to be determined.

CONSULTATION DRAFT

8.3.1.8.1.1.4 Activity: Probability calculations and assessment

Objectives

The objective of this activity is to revise the estimates of the probability of volcanic disruption of a repository site at Yucca Mountain (Crowe et al., 1982) incorporating newly acquired data on the age, location, and volume of volcanic centers in the NTS region and the results from activities investigating the possibility of structural controls of sites of volcanic activity and the presence of magma bodies in the Yucca Mountain area. These data may result in modifications of the area ratio and the rate of volcanic activity used in the probability formula.

Parameters

The parameters for this activity are

1. Maps showing the location and age of volcanic vents within 70 km of the site.
2. Magma generation rates within 70 km of the site.
3. Structural controls on volcanism.
4. Evidence for the presence of magma bodies in the vicinity of the site.

Description

Data from parameters 1 through 4 are used for probability calculations. The probability of disruption of a repository by basaltic magma is formulated as a case of conditional probability

$$Pr = \{E2 \text{ given } E1\} \quad (8.3.1.8-1)$$

where Pr is the probability of repository disruption, $E1$ is the rate of occurrence of volcanic events, and $E2$ is the probability of intersection of a repository by magma given $E1$. This probability is expressed as (Crowe et al., 1982)

$$Pr [\text{no disruptive event before time } t] = e^{-\lambda tp} \quad (8.3.1.8-2)$$

where λ is the rate of volcanic activity and p is the probability that an event is disruptive. The most difficult parameter to estimate for the calculations is λ . The NNWSI Project has defined the parameter λ in two ways using data for the Yucca Mountain region: (1) cone counts through time and (2) calculations of magma volume through time (rate of magma production). Alternative models are possible but are difficult to test with the limited data from the Yucca Mountain region. Much more comprehensive data will be obtained from high cone-density volcanic fields. These data will be used to test existing methods for calculating volcanic rates and developing additional alternative methods. If new methods are developed, they will be

CONSULTATION DRAFT

tested using the Yucca Mountain data set. Further work will be undertaken to attempt to revise the probability of repository disruption (p). Cluster analysis of the aeromagnetic and gravity data will be used to attempt to correlate spatial trends with sites of surface volcanic activity. If these correlations are successful, the disruption ratio will be revised for the probability calculations. Ongoing work described in Chapter 1 has shown that there has been a progressive southwest migration of sites of basaltic volcanic activity through time. These data lead to the conclusion that the Yucca Mountain region has passed the peak of the most intense volcanic activity. This interpretation will be tested using information on time-space patterns of basaltic volcanism from Activity 8.3.1.8.1.1.1. The results of the revised probability calculation and assessment will be summarized in a report that includes the following:

1. A summary of the data and calculations used in the assessment.
2. The results of the assessment on the probability of volcanic events.
3. An analysis of the assumptions and uncertainties in the data and the assessment.

Methods and technical procedures

The method and technical procedure for this activity are given in the following table.

Method	Technical procedure		Date
	Number	Title	
Probability modeling	TWS-INC-WP-12, R0	Volcanic hazard investigations work plan	24 Nov 82

8.3.1.8.1.2 Study: Effects of a volcanic eruption penetrating the repository

The purpose of this study is to gather data on the effects of a potential volcanic eruption should such an eruption penetrate the site. The data will be used by Issue 1.1 and the other investigations in this program to assess the consequences of such an eruption on repository performance.

8.3.1.8.1.2.1 Activity: Effects of Strombolian eruptions

Objectives

The objective of this activity is to summarize the effects of a

CONSULTATION DRAFT

Strombolian eruption on a repository. The summary will be available for use in consequence analyses of possible radiological releases.

Parameters

The parameters for this activity are representative eruption parameters for Strombolian eruptions including area of repository disrupted and confidence bounds of estimate.

Description

The published literature and completed Project reports (e.g., Link et al., 1982) provide sufficient data for the completion of this activity. This activity will compile and summarize those data for use in consequence analyses.

The data used will include the area of the repository that could potentially be disrupted, characteristics and dimensions of intrusions (dikes and sills) associated with an eruption, thickness and extent of flows and ashfalls, temperatures of magma, and duration of eruptions. The data summarized by this activity will also be used in Investigations 8.3.1.8.2, 8.3.1.8.3, and 8.3.1.8.4.

Methods and technical procedures

The method and technical procedure for this activity are given in the following table.

Method	Technical procedure		Date
	Number	Title	
Analysis of data	TWS-INC-WP-12, R0	Volcanic hazard investigations work plan	24 Nov 82

8.3.1.8.1.2.2 Activity: Effects of hydrovolcanic eruptions

Objectives

The objective of this activity is to obtain geologic parameters for the disruption of a repository by magmatic activity accompanied by hydrovolcanic (magma-water) explosions. Critical parameters controlling the hydrovolcanic explosions will be identified and information obtained on these parameters will be used for calculations of the radiological release levels for performance assessment.

CONSULTATION DRAFT

Parameters

The parameters for this activity are the representative eruption parameters for hydrovolcanic eruptions including the area of repository disrupted and the confidence bounds of the estimate.

Description

Eruption parameters will be defined for an eruption scenario involving an initial hydrovolcanic eruption changing in time to a Strombolian eruption. Parameters for a Strombolian eruption without a hydrovolcanic component have been completed (Link et al., 1982). There are two important categories of evidence related to the possibility of hydrovolcanic activity at Yucca Mountain: (1) theoretical models of magma/water interaction show that hydrovolcanic explosions are possible in the Yucca Mountain setting, and (2) geologic evidence suggests that the likelihood of a hydrovolcanic explosion decreases with increasing depth of the water source (Crowe et al., 1986). Consequence studies of the area of the repository disrupted by a basaltic eruption need to be repeated with a modified eruption scenario that includes hydrovolcanic explosions. Two topics require further studies for these modifications. First, likely scenarios for hydrovolcanic eruptions need to be identified based on information obtained from field studies of basalt centers that exhibited hydrovolcanic activity (Activity 8.3.1.8.5.1.3) and a review of the literature should be conducted. Second, data on key geologic parameters need to be obtained from the scenarios. The data needed will be used to predict (1) whether an ascending magma body will intersect water at a depth to cause an explosive fuel-coolant type reaction between magma and water, and (2) whether that reaction will be of sufficient magnitude to cause an explosive eruption that will disrupt the repository, possibly breach waste canisters, and cause the release of radioactive waste at the surface.

Methods and technical procedures

The method and procedure for this activity are given in the following table.

Method	Technical procedure		Date
	Number	Title	
Analysis of data	TWS-INC-WP-12, R0	Volcanic hazard investigations work plan	24 Nov 82

CONSULTATION DRAFT

8.3.1.8.1.3 Application of results

The information derived from the studies and activities described above will be used in the following issues and investigations.

<u>Issue or investigation</u>	<u>Subject</u>
1.1	Total system performance (Section 8.3.5.13)
1.8	NRC siting criteria (Section 8.3.5.17)
1.9	Higher level findings-postclosure (Section 8.3.5.18)
8.3.1.8.2	Tectonic effects on waste package
8.3.1.8.3	Tectonic effects on hydrology
8.3.1.8.4	Tectonic effects on geochemistry
8.3.1.9.1	Degradation of markers
8.3.1.17.1	Volcanic activity

Additionally, Investigation 8.3.1.8.1 will provide information to Investigation 8.3.1.17.4, which will be used to develop working models of the tectonic framework of the Yucca Mountain region. It is important that models of the tectonic setting of volcanism are consistent with the models of the tectonic framework.

8.3.1.8.1.4 Schedule and milestones

This investigation, addressing postclosure volcanic activity, contains two studies: 8.3.1.8.1.1 (probability of a volcanic eruption penetrating the repository) and 8.3.1.8.1.2 (effects of a volcanic eruption penetrating the repository). Both of these studies are ongoing.

In the figure that follows, the schedule information for these studies is presented in the form of timelines. The timelines extend from implementation of the approved study plans to the issuance of the final products associated with the studies. Summary schedule and milestone information of this investigation can be found in Section 8.5.1.1.

The activities of this entire investigation are planned to progress in parallel with performance and design activities in an iterative fashion. The results of these studies will be used to resolve Issue 1.1 (total system performance) and to support advanced conceptual and license application designs.

CONSULTATION DRAFT

The studies in this investigation are constrained by other program elements, as follows: Study 8.3.1.8.1.1 depends on the characterization of volcanic and igneous intrusive features (Studies 8.3.1.8.5.1 and 8.3.1.8.5.2). Study 8.3.1.8.1.2 depends upon data on the nature of hydrovolcanic eruptions from Study 8.3.1.8.5.1.

The study numbers and titles corresponding to the timelines are shown on the left of the following figure. The points shown on the timelines represent major events or important milestones associated with the study. Solid lines represent study durations and dashed lines show interfaces. The data input and output at the interfaces are shown by circles.

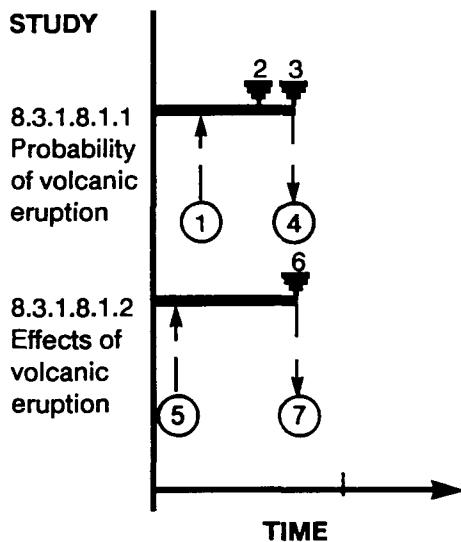

831815-VA

The points on the timeline and the data input and output at the interfaces are described in the following table:

<u>Point number</u>	<u>Description</u>
1	Data available on dating, location, and volume of flows; geochemical patterns of volcanism in the Great Basin; and anomalies that indicate the presence of magma bodies from Studies 8.3.1.8.5.1 and 8.3.1.8.5.2.
2	Milestone Z001. Final report available on volcanic chronology for volcanic risk assessment. Available for use by Issue 1.1 (total system performance).
3	Probability calculations for risk assessment completed.
4	Input to Issue 1.1 on results of study.
5	Data available from Study 8.3.1.8.5.1 on the nature of hydrovolcanic eruptions in the site region

CONSULTATION DRAFT

<u>Point number</u>	<u>Description</u>
6	Milestone Z378. Summary report available on effects of igneous and volcanic effects.
7	Results of Study 8.3.1.8.1.2 input to Issue 1.1.

8.3.1.8.2 Investigation: Studies to provide information required on rupture of waste packages due to tectonic events

Technical basis for obtaining the information

Links to the technical data chapters and applicable support documents

The following sections of the SCP data chapters provide a technical summary of existing data relevant to this investigation:

<u>SCP section</u>	<u>Subject</u>
1.3.2.1	Volcanic history
1.3.2.2	Structural history
1.4.1.5	Seismic hazard within the southern Great Basin
1.5.1	Volcanism
1.5.2	Faulting

Parameters

The following performance parameters will be measured or calculated as a result of the site studies planned as part of this investigation:

1. Probability of igneous intrusion penetrating repository.
2. Effects of igneous intrusion penetrating repository.
3. Effects on waste packages of a fault penetrating the repository.
4. Probability of faulting with displacement over 5 cm in repository.
5. Expected ground motion at emplacement boreholes in 1,000-yr period.
6. Rate of deformation due to folding or distributed faulting in repository horizon.

Purpose and objectives of the investigation

The purpose of this investigation is to provide the data necessary for an analysis and assessment of repository performance with respect to the possibility of tectonic processes and events affecting the lifetime of waste packages. The six performance parameters listed in the previous section have been defined to address the performance measure identified by Issue 1.11 (Section 8.3.2.2). The types of tectonic initiating events that may affect

CONSULTATION DRAFT

waste package performance and that will be considered in this analysis are listed in Table 8.3.1.8-2. The study and activities in this investigation will take data gathered by field studies in this and other programs and provide an analysis of the probability of the initiating events and their effects on waste package performance for use by Issue 1.11 (Section 8.3.2.2) in assessing layout and design of the underground facilities.

This investigation will also provide data on the nature of tectonic processes operating at the site for use by Issue 1.8 (Section 8.3.5.17, NRC siting criteria) in its analysis of favorable and potentially adverse conditions. The specific conditions addressed by this investigation are listed in Table 8.3.1.8-2.

Parameter 5 indicates the need for data on the ground motion that would be expected during the waste package lifetime. This parameter and its related initiating event respond to the need identified in Issue 1.11 (Section 8.3.2.2, configuration of underground facilities (postclosure)) for such data. Issue 1.11 will use the ground motion data to evaluate the design of emplacement drifts and boreholes in order to assess their postclosure stability.

Technical rationale for the investigation

The flow of data and interconnections between activities is shown on Figure 8.3.1.8-4. The first initiating event considered in this program is the possibility that igneous intrusions penetrating the repository could adversely affect waste package performance. This initiating event is similar to the one considered in Investigation 8.3.1.8.1, but assumes that the basaltic dikes or sills that might penetrate the repository do not feed a volcanic vent and do not directly result in releases at the ground surface. Activity 8.3.1.8.2.1.1 will address this initiating event and satisfy parameters 1 and 2. The assessment of this initiating event will be similar to that in Investigation 8.3.1.8.1 and will use the data analyzed in that investigation to calculate the probability of igneous intrusions penetrating the repository. The number of waste packages that an intrusion might intersect will also be calculated using data on the probable length, width, and orientation of intrusions and current repository design concepts.

The second initiating event considers the possibility that failure of waste packages could occur due to a fault that intersects waste packages and experiences offset that is great enough to cause failure through shearing. Activities 8.3.1.8.2.1.2, 8.3.1.8.2.1.3, and 8.3.1.8.2.1.4 will assess this initiating event and satisfy parameters 3 and 4. This assessment will include calculating (1) the probability that faulting with offset great enough to cause waste package failure would occur in the repository and (2) the number of waste packages that a through going fault might intersect. These activities will organize and assess data collected by Programs 8.3.1.17 and 8.3.1.4 to characterize the nature and Quaternary activity of faults that penetrate the repository and those faults in and near the controlled area. Because of the scarcity of Quaternary deposits on Yucca Mountain, it may not be possible to directly demonstrate the degree of Quaternary activity present on all the faults that potentially penetrate the repository. It is therefore probable that the assessment of the probability and amount of movement on these faults will be characterized by comparison with the known Quaternary

INTERMEDIATE PERFORMANCE MEASURE

DATA ANALYSIS AND ASSESSMENT

DATA REQUIRED

KEY DATA GATHERING ACTIVITIES

8.3.1.8-47

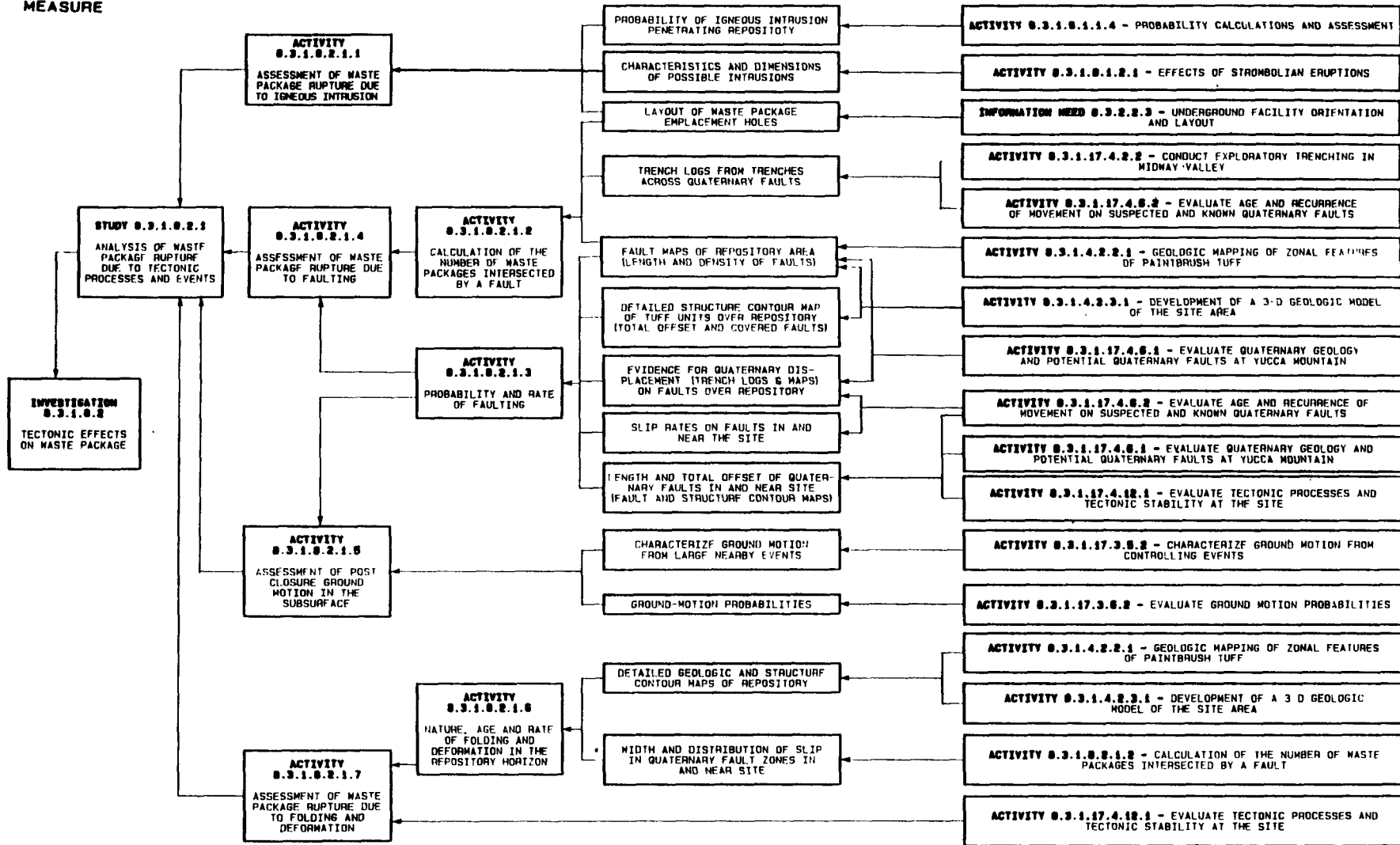

CONSULTATION DRAFT

Figure 8.3.1.8-4. Logic diagram for Investigation 8.3.1.8.2 (tectonic effects on waste package).

CONSULTATION DRAFT

faults in the vicinity of the site that have a similar trend and sense of movement. Faults such as the Paintbrush Canyon, Solitario Canyon, and Windy Wash traverse areas underlain by Quaternary deposits of a variety of ages (Sections 1.2.2.3 and 1.3.2.2.2) that can be used to determine the nature and rate of Quaternary activity. The comparison of the faulting potential of these larger faults with faults penetrating the repository will incorporate a consideration of the differences in length and total displacement between the two classes of faults. When all these data are collected and coordinated, an annual probability of fault displacement exceeding 5 cm will be calculated for faults that may penetrate the repository.

The second part of the assessment will be a calculation of the number of waste packages that a fault might intersect should a faulting event, with sufficient offset to rupture waste packages, occur. Data will be compiled on the length and width of fault zones, and then calculations similar to those in Link et al. (1982) will be carried out using current repository designs to estimate the number of waste packages that might be affected.

The third initiating event considers the possibility that ground motion occurring during the postclosure period could cause spalling or failure in the underground workings that would result in corrosion or mechanical failure of waste packages due to closure of the air gap around them. Activity 8.3.1.8.2.1.5 will partially address this initiating event and address parameter 5 by calculating expected ground motion values in the repository during the lifetime of the waste packages. The performance of underground excavations under these ground motion conditions will be evaluated separately in Issue 1.11 (Section 8.3.2.2). In this investigation, the ground motion estimates for preclosure design in Investigation 8.3.1.17.3 will be reviewed. Appropriate ground motion parameters for the postclosure time period will then be calculated on the basis of this data.

The fourth initiating event considers the possibility that folding, or fault offset distributed across a broad zone of minor shearing, could sufficiently deform the waste-emplacement boreholes through a closure of the air gap surrounding the waste packages such that the waste packages would fail through bending. Activities 8.3.1.8.2.1.6 and 8.3.1.8.2.1.7 will address this initiating event and satisfy parameter 6. These activities will collect data on rates and amount of post-Miocene folding in the repository horizon by reviewing the detailed geologic and structure contour maps of the repository horizon generated by Program 8.3.1.4. Rates of deformation will then be calculated using these data, and a probability of significant waste package failure due to deformation processes calculated.

8.3.1.8.2.1 Study: Analysis of waste package rupture due to tectonic processes and events

The assessment of the probability and effects of all tectonic processes and events that could result in adverse effects on waste package lifetime are aggregated under this study.

CONSULTATION DRAFT

8.3.1.8.2.1.1 Activity: Assessment of waste package rupture due to igneous intrusion

Objectives

The objective of this activity is to review and organize supporting field data collected by other activities, and to use this data to calculate the probability of an igneous intrusion penetrating the repository and the number of waste packages that would be affected by such an event.

Parameters

The parameters for this activity are

1. Probability of an igneous intrusion penetrating the repository.
2. Number of waste packages affected by an igneous intrusion.

Description

This activity will use the data and probability calculations in Activity 8.3.1.8.1.1.4 as the basis for estimating the probability that an igneous intrusion may penetrate the repository. The results of Link et al. (1982) will be reviewed and compared with current repository designs and the results of Activity 8.3.1.8.1.2.1 to calculate the number of waste packages that might be intersected by an igneous intrusion. These previous estimates will be revised as necessary to incorporate current data and designs. A report will be prepared that

1. Organizes and summarizes the data on which calculations are based.
2. Presents the theory and calculations used to estimate the probability of igneous intrusion and the number of waste packages affected.
3. Presents a discussion and assessment of the assumptions and uncertainties of the data and the calculations.

Methods and technical procedures

Activity 8.3.1.8.2.1.1 will only synthesize and compile data collected by other activities and will use the methods and technical procedures given in the following table.

CONSULTATION DRAFT

Method	Technical procedure		Date
	Number	Title	
Analysis of data	QP 3.1	Scientific investigation control and design control	20 Dec 86
Use of data from non-Project sources	NNWSI-SOP-03-03	Acceptance of data or data interpretation not developed under the NNWSI Project QA Plan	31 Jan 86

8.3.1.8.2.1.2 Activity: Calculation of the number of waste packages intersected by a fault

Objectives

The objective of this activity is to collect and summarize the relevant data from other activities and calculate the number of waste packages that a fault penetrating the repository would intersect.

Parameters

The parameter for this activity is the number of waste packages affected by a fault penetrating the repository.

Description

This activity will review data collected by trenching and geologic mapping activities in and around the site by Programs 8.3.1.4 and 8.3.1.17. The data on the length, width, and orientation of known Quaternary fault ruptures will be summarized. Representative values for these fault characteristics will be selected for use in calculations. Current repository designs will be reviewed to collect data on the layout and emplacement mode of waste packages. These data will be used to calculate the number of waste packages that a fault might intersect in the repository. The calculation method will be similar to that used by Link et al. (1982) for volcanic events and will result in a probability distribution of possible effects.

Methods and technical procedures

Activity 8.3.1.8.2.1.2 will only synthesize and compile data collected by other activities and will use the methods and technical procedures given in the following table.

CONSULTATION DRAFT

Method	Number	Technical procedure	
		Title	Date
Analysis of data	QP 3.1	Scientific investigation control and design control	20 Dec 86
Use of data from non-Project sources	NNWSI-SOP-03-03	Acceptance of data or data interpretation not developed under the NNWSI Project QA Plan	31 Jan 86

8.3.1.8.2.1.3 Activity: Probability and rate of faulting

Objectives

The objective of this activity is to summarize and evaluate the available data on slip rates and recurrence intervals on faults in and near the controlled area.

Parameters

The parameters for this activity are

1. Evidence of Quaternary activity on faults penetrating the repository.
2. Density, length and total displacement of faults penetrating the repository.
3. Slip rates and recurrence intervals of faults with Quaternary activity in and near the controlled area.
4. Location, length, and total displacement of faults with Quaternary activity in and near the controlled area.

Description

This activity will collect and summarize data on the length, total displacement, and Quaternary activity of faults that are mapped in and near the controlled area and can be projected downward or laterally to intersect the repository. The data will be gathered by several activities in Programs 8.3.1.4 and 8.3.1.17 (Figure 8.3.1.8-4). The data will consist of detailed bedrock geologic maps, structure contour maps, Quaternary deposits maps, remote sensing and geomorphic analyses, and trench logs. The various types of data available will be analyzed and compared with each other to generate a summary of the characteristics of these faults.

CONSULTATION DRAFT

Data will also be collected and summarized on the length, total displacement, slip rate, and recurrence interval of Quaternary faults such as the Paintbrush Canyon, Solitario Canyon, and Windy Wash that are in and near the controlled area. These data will come from trenching and mapping studies carried out mainly by Activities 8.3.1.17.4.6.1 and 8.3.1.17.4.6.2. The analyses and data summaries will be used by Activity 8.3.1.8.2.1.4 to assess the probability of significant effects on waste package lifetime due to faulting.

Methods and technical procedures

Activity 8.3.1.8.2.1.3 will only synthesize and compile data collected by other activities and will use the methods and technical procedures given in the following table.

Method	Number	Technical procedure	
		Title	Date
Analysis of data	QP 3.1	Scientific investigation control and design control	20 Dec 86
Use of data from non-Project sources	NNWSI-SOP-03-03	Acceptance of data or data interpretation not developed under the NNWSI Project QA Plan	31 Jan 86

8.3.1.8.2.1.4 Activity: Assessment of waste package rupture due to faulting

Objectives

The objective of this activity is to complete an assessment of the probability of faulting in waste emplacement boreholes and effects of faulting on waste package lifetime.

Parameters

The parameters for this activity are

1. Effects on waste packages of a fault penetrating the repository.
2. Probability of faulting with a displacement over 5 cm in the repository.

CONSULTATION DRAFT

Description

This activity will take the data summarized and compiled by Activities 8.3.1.8.2.1.2 and 8.3.1.8.2.1.3 and prepare an assessment of the hazard posed by fault displacement to waste package lifetime. The results of this assessment will be contained in a report that includes the following topics:

1. A summary of data on the characteristics of the faults projected to intersect the repository.
2. A summary of data on the characteristics of the Quaternary faults in and near the controlled area.
3. The calculation of the probability of a cumulative 5-cm displacement occurring in 1,000 yr on a known Quaternary fault in and near the controlled area using slip rates or recurrence intervals and including the type of analysis presented in URS/Blume (1987).
4. A comparison of the characteristics of known Quaternary faults in and near the controlled area with the characteristics of faults projected to intersect the repository and an estimation of the probability of a cumulative 5-cm displacement occurring in 1,000 yr on a fault intersecting the repository.
5. An evaluation of the number of faults penetrating the repository on which cumulative displacements greater than 5 cm could occur during a 1,000 yr period and the interrelationship of events on different faults.
6. The calculation of the number of waste packages that a fault penetrating the repository would intersect.
7. An analysis of the assumptions and uncertainties contained in the data and calculations used for the assessment.

Methods and technical procedures

Activity 8.3.1.8.2.1.4 will only synthesize and compile data collected by other activities and will use the methods and technical procedures given in the following table.

Method	Technical procedure		
	Number	Title	Date
Analysis of data	QP 3.1	Scientific investigation control and design control	20 Dec 86

CONSULTATION DRAFT

Method	Number	Technical procedure	
		Title	Date
Use of data from non-Project sources	NNWSI-SOP-03-03	Acceptance of data or data interpretation not developed under the NNWSI Project QA Plan	31 Jan 86

8.3.1.8.2.1.5 Activity: Assessment of postclosure ground motion in the subsurface

Objectives

The objective of this activity is to provide an assessment of expected ground motion at the repository horizon in a 1,000-yr period.

Parameters

The parameter for this activity is the expected ground motion at emplacement boreholes in 1,000-yr period.

Description

This activity will supply data that will be used by Issue 1.11 (Section 8.3.2.2) to analyze the postclosure performance of the underground workings under earthquake loading conditions. Data from Studies 8.3.1.17.3.5 and 8.3.1.17.3.6 will be used to characterize ground motions that have a probability of less than 0.1 of being exceeded in the 1,000-yr waste package lifetime. Time histories representative of the estimated ground motions at the repository horizon will be prepared for use in the engineering evaluations. A report will be prepared that

1. Summarizes the data used in the analysis.
2. Discusses the methods used to estimate expected ground motion levels.
3. Analyzes the assumptions and uncertainties in the data and estimation methods.
4. Provides time histories and other data characterizing expected ground motion parameters for use in engineering analysis.

CONSULTATION DRAFT

Methods and technical procedures

Activity 8.3.1.8.2.1.5 will only synthesize and compile data collected by other activities and will use the methods and technical procedures in the following table.

Method	Number	Technical procedure	Date
		Title	
Analysis of data	QP 3.1	Scientific investigation control and design control	20 Dec 86
Use of data from non-Project sources	NNWSI-SOP-03-03	Acceptance of data or data interpretation not developed under the NNWSI Project QA Plan	31 Jan 86

8.3.1.8.2.1.6 Activity: Nature, age, and rate of folding and deformation in the repository horizon

Objectives

The objective of this activity is to provide an estimate of the rate of folding or deformation in the repository horizon during Quaternary time.

Parameters

The parameters for this activity are

1. Wavelength and amplitude of folds in the Miocene rocks of the repository horizon.
2. Amount and nature of deformation resulting from faulting in the repository horizon.

Description

This activity will collect and analyze data from Program 8.3.1.4 (rock characteristics) to characterize folding in the repository horizon. The data evaluated will include geologic maps, detailed structure contour maps, and maps of the shafts and drifts. Data on the wavelength and amplitude of any folds found in the area of the repository will be summarized. The site data will also be reviewed for evidence of warping, distributed shear or faulting. Data on the width of Quaternary zones of deformation around faults in the

CONSULTATION DRAFT

area will also be taken from Activity 8.3.1.8.2.1.2. All the data will be used by Activity 8.3.1.8.2.1.7 in its evaluation of the rate of folding and deformation in the repository and its effect on waste package integrity.

Methods and technical procedures

Activity 8.3.1.8.2.1.6 will only synthesize and compile data collected by other activities and will use the methods and technical procedures given in the following table.

Method	Technical procedure		
	Number	Title	Date
Analysis of data	QP 3.1	Scientific investigation control and design control	20 Dec 86
Use of data from non-Project sources	NNWSI-SOP-03-03	Acceptance of data or data interpretation not developed under the NNWSI Project QA Plan	31 Jan 86

8.3.1.8.2.1.7 Activity: Assessment of waste package rupture due to folding and deformation

Objectives

The objective of this activity is to provide an assessment of the hazard resulting from folding and deformation to waste package integrity.

Parameters

The parameter for this activity is the rate of deformation due to folding or faulting in the repository horizon.

Description

This activity will use the data generated by Activity 8.3.1.8.2.1.6 and data on the rate and changes in deformation in the Neogene from Study 8.3.1.17.4.12 to estimate the rate of folding or deformation in the repository horizon and describe the effects such folding may have on waste package integrity. This activity will result in a report that will include

1. The data used in making the assessment.
2. The methods used to calculate or estimate Quaternary folding rates.

CONSULTATION DRAFT

3. Quaternary folding rates and an assessment of the impact on waste package integrity.
4. An analysis of the assumptions and uncertainties in the data and the assessment.

Methods and technical procedures

Activity 8.3.1.8.2.1.7 will only synthesize and compile data collected by other activities and will use the methods and technical procedures given in the following table.

Method	Technical procedure		Date
	Number	Title	
Analysis of data	QP 3.1	Scientific investigation control and design control	20 Dec 86
Use of data from non-Project sources	NNWSI-SOP-03-03	Acceptance of data or data interpretation not developed under the NNWSI Project QA Plan	31 Jan 86

8.3.1.8.2.2 Application of results

The information derived from the study and activities described above will be used in the following issues and investigations:

<u>Issue or investigation</u>	<u>Subject</u>
1.8	NRC siting criteria (Section 8.3.5.17)
1.9	Higher level findings - Postclosure (Section 8.3.5.18)
1.11	Configuration of underground facilities (postclosure) (Section 8.3.2.2)
8.3.1.8.3	Tectonic effects on hydrology
8.3.1.8.4	Tectonic effects on geochemistry

8.3.1.8.2.3 Schedule and milestones

This investigation addresses postclosure tectonic effects on the waste package and contains one out-year study: 8.3.1.8.2.1 (analysis of waste package rupture due to tectonic processes and events). In the figure that follows, the schedule information for this study is presented in the form of a timeline. The timeline extends from implementation of the approved study plan to the issuance of the final product associated with the study. Summary schedule and milestone information for this investigation can be found in Section 8.5.1.1.

The activities of this entire investigation are planned to progress in parallel with performance and design activities in an iterative fashion. The results of this study will be used to resolve Issue 1.11 (configuration of underground facilities (postclosure)), and to support advanced conceptual and license application designs, and waste package performance evaluation and design.

Completion of this study is constrained by the availability of data on the probability and dimensions of igneous intrusions from Investigation 8.3.1.8.1, underground design data from Information Need 8.3.2.2.3, exploratory trench data from Investigation 8.3.1.17.4, detailed geologic and structure contour maps from Investigation 8.3.1.4.2, and data on expected ground motions from Investigation 8.3.1.17.3.

The study number and title corresponding to the timeline are shown on the left of the following figure. The points shown on the timeline represent major events or important milestones associated with the study. Solid lines represent study durations, and dashed lines show interfaces. The data input and output at the interfaces are shown by circles.

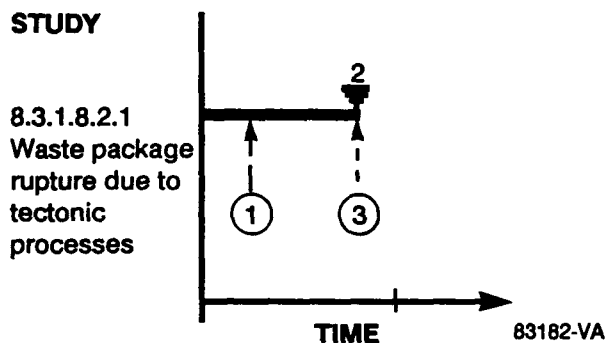

CONSULTATION DRAFT

The points on the timeline and the data input and output at the interfaces are described in the following table:

<u>Point number</u>	<u>Description</u>
1	Data available from Investigations 8.3.1.8.1 (volcanic activity), 8.3.1.17.3 (vibratory ground motion), 8.3.1.17.4 (preclosure tectonic data collection analysis), and 8.3.1.4.2 (geologic framework), and Information Need 8.3.2.2.3 (underground facility orientation and layout).
2	Milestones Z379, Z380, and Z382. A series of reports to be available for use by Issue 1.11 (configuration of underground facilities (postclosure)), assessing the effects on waste package integrity resulting from faulting, folding, deformation, and igneous intrusive processes, and on expected repository ground motions during the postclosure period (Milestone Z381).
3	Data input to Issue 1.11 from reports assessing the effects of faulting, folding, deformation and igneous intrusive processes on waste package performance.

8.3.1.8.3 Investigation: Studies to provide information required on changes in unsaturated and saturated zone hydrology due to tectonic events

Technical basis for obtaining the information

Links to the technical data chapters and applicable support documents

The following sections of the SCP data chapters provide a technical summary of existing data relevant to this investigation:

<u>SCP section</u>	<u>Subject</u>
1.3.2.1	Volcanic history
1.3.2.2	Structural history
1.3.2.3	Existing stress regime
1.5.1.2	Basaltic volcanism
1.5.2	Faulting
3.6	Regional hydrogeologic reconnaissance of candidate area and site
3.9	Site hydrogeologic system

CONSULTATION DRAFT

Parameters

The following performance parameters will be measured or calculated as a result of the site studies planned as part of this investigation:

1. Annual probability of volcanic events within the controlled area.
2. Effects of a volcanic event on topography and average flux rates.
3. Annual probability of significant igneous intrusion within 0.5 km of the controlled area.
4. Effects of an igneous intrusion on average flux rates.
5. Probability of offset more than 2 m on a fault in the controlled area in 10,000 yr.
6. Probability of changing dip by greater than 2 degrees in 10,000 yr by faulting.
7. Effect of faulting on average flux rates.
8. Probability of changing dip by greater than 2 degrees in 10,000 yr by folding.
9. Probability of exceeding 30 m of elevation change in 10,000 yr.
10. Barrier-to-flow effects of igneous intrusions on water-table levels and hydraulic gradients.
11. Thermal effects of igneous intrusions on water-table levels and hydraulic gradients
12. Probability that strain-induced changes will increase potentiometric level to greater than 850 m mean sea level (MSL).
13. Probability that repository will be lowered by 100 m through action of folding, uplift, or subsidence in 10,000 yr.
14. Probability of total offsets more than 2.0 m in 10,000 yr on a fault within 0.5 km of controlled area boundary.
15. Effects of fault offset on water-table levels and hydraulic gradient.
16. Effects of igneous intrusions on local fracture permeabilities and effective porosities.
17. Annual probability of faulting events on Quaternary faults within 0.5 km of controlled area boundary.
18. Effects of fault motion on local fracture permeabilities and effective porosities.

CONSULTATION DRAFT

19. Effects of changes of stress or strain on hydrologic properties of the rock mass.

Purpose and objectives of the investigation

The 19 performance parameters listed above have been identified by Issue 1.1 (Section 8.3.5.13 and Tables 8.3.1.8-3 to 8.3.1.8-5) to address the possibility that tectonic processes and events could produce the following changes in existing hydrologic conditions:

1. Alteration of average percolation flux over the repository.
2. Changes in water table elevation that affect the length of the unsaturated zone travel path or hydraulic gradients.
3. Alteration of rock hydrologic properties along significant travel paths.

The three studies in this investigation will provide assessments of the likelihood and magnitude of these hydrologic changes for use by Issue 1.1 in analyzing total system performance of the repository in limiting radionuclide releases to the accessible environment. Several of the initiating events considered in this investigation probably will have no significant impact on repository performance because of the very low rates at which the related tectonic processes operate at Yucca Mountain (e.g., folding, uplifting, and subsidence). It is anticipated that little or no additional data will be required to complete the assessments of the initiating events related to these tectonic processes. The level of effort for the activities related to these initiating events is therefore anticipated to be low and to consist primarily of organizing and presenting existing data in order to provide the basis for eliminating these initiating events from consideration during performance assessment evaluations.

This investigation will also provide data on the nature of tectonic processes operating at the site for use by Issue 1.8 (Section 8.3.5.17, NRC siting criteria) in its analysis of favorable and potentially adverse conditions. The specific conditions addressed by this investigation are listed on Tables 8.3.1.8-3 to 8.3.1.8-5.

Technical rationale for the investigation

The flow of data and interconnections between activities in each study are shown on Figures 8.3.1.8-5 to 8.3.1.8-7. Study 8.3.1.8.3.1 considers the initiating events that may affect the average percolation flux over the repository. The first initiating event considered in this study is the possibility that volcanic events may alter topography as a result of the extrusion of volcanic flows or other effects and create impoundments or diversions of drainage that could adversely affect average percolation flux rates. The second initiating event considers the possibility that an igneous intrusion such as a sill intruded above the repository horizon could divert downward percolating waters to the area above the repository and thereby increase average percolation flux rates. The first two activities in the study address these initiating events and will satisfy parameters 1 to 4. Activity 8.3.1.8.3.1.1 will use data from Activity 8.3.1.8.1.1.4 to calculate

INTERMEDIATE PERFORMANCE MEASURE

DATA ANALYSIS AND ASSESSMENT

DATA REQUIRED

KEY DATA GATHERING ACTIVITIES

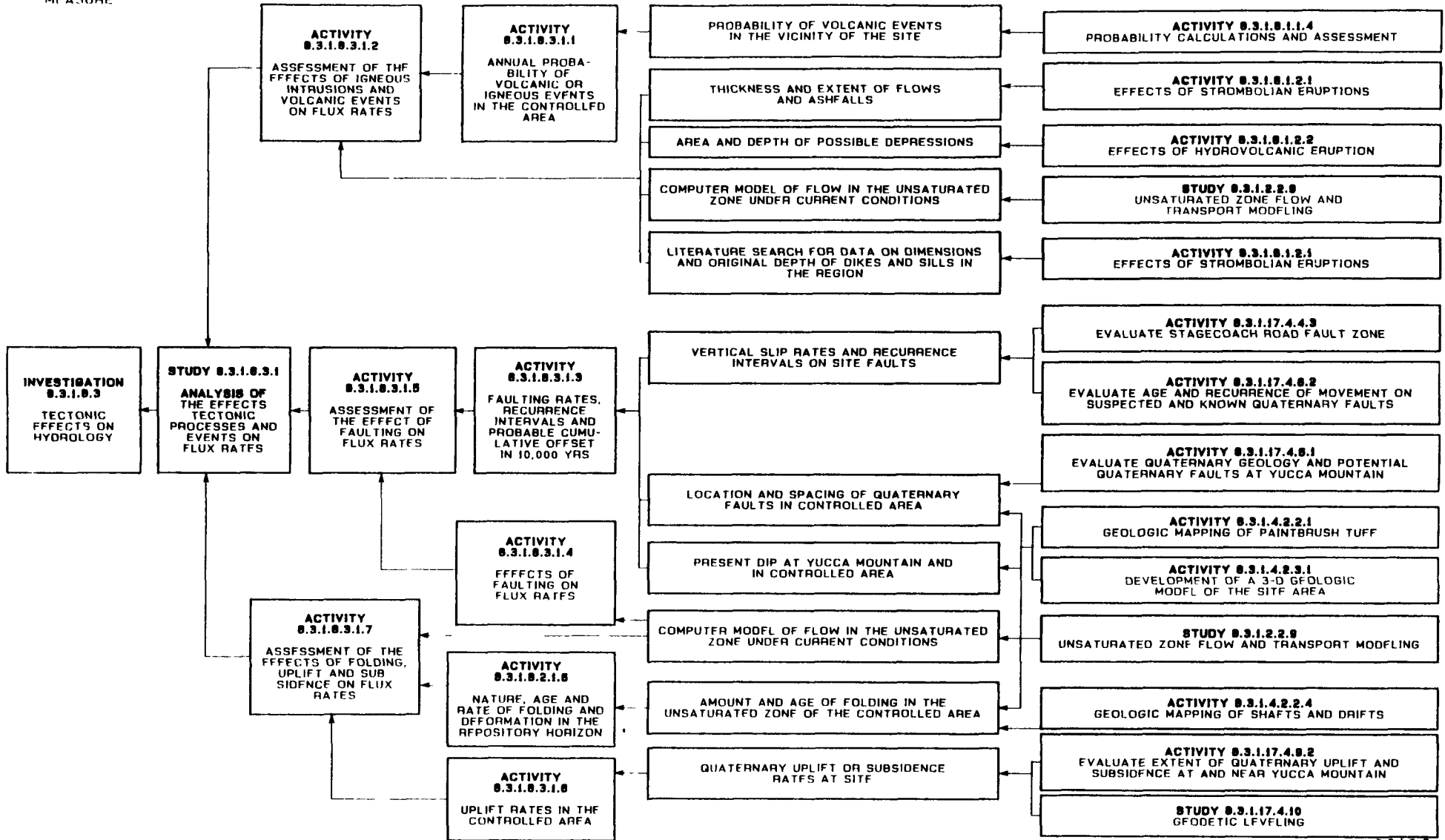

CONSULTATION DRAFT

8 3 1 8-5r

Figure 8.3.1.8-5. Logic diagram for Study 8 3 1 8 3 1 (analysis of the effects of tectonic processes and events on flux rates)

8.3.1.8-62

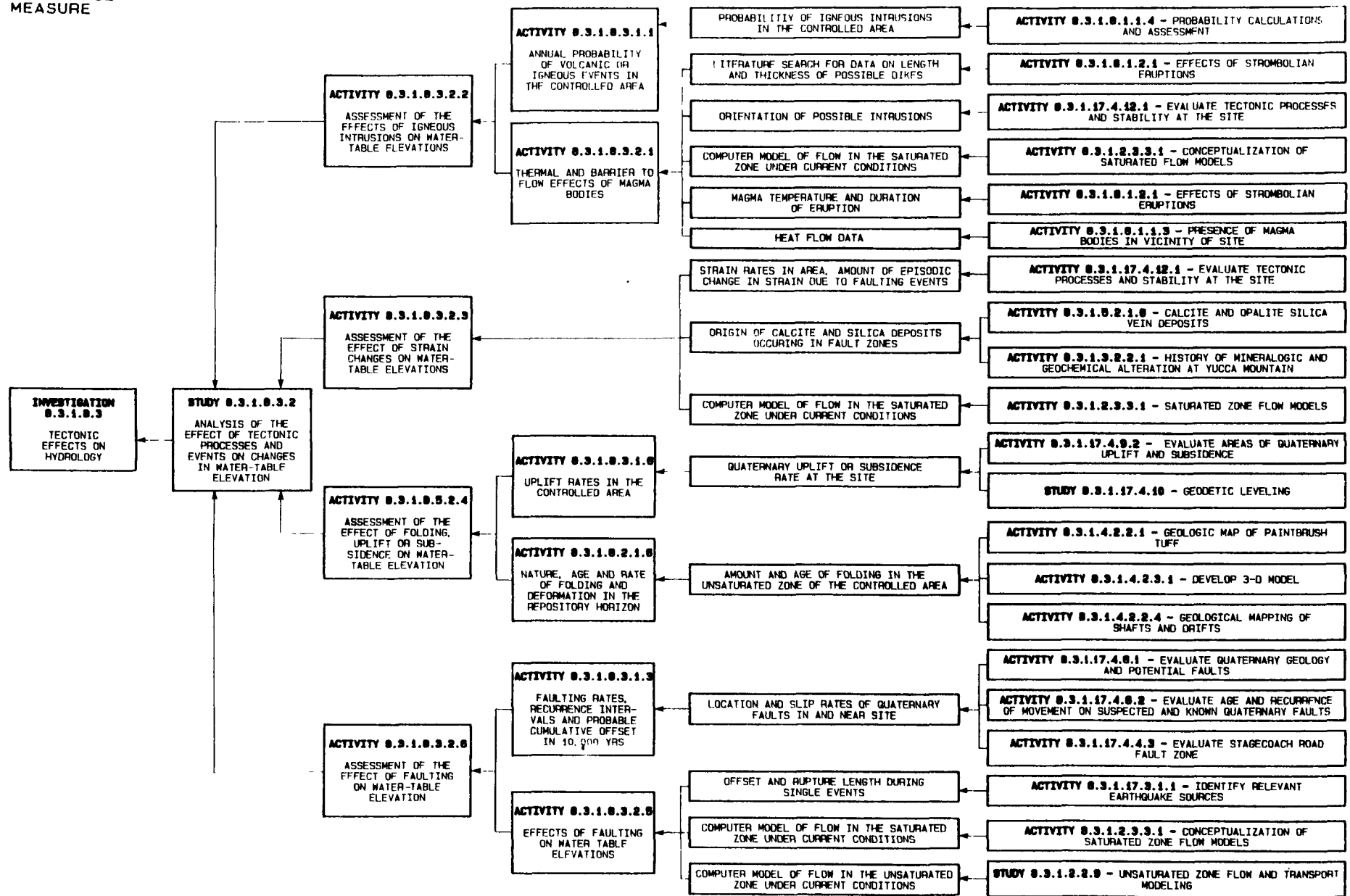

Figure 8.3.1.8-6. Logic diagram for Study 8.3.1.8.3.2 (analysis of effects of tectonic processes and events on changes in water-table elevation).

**INTERMEDIATE
PERFORMANCE MEASURE**

DATA ANALYSIS AND ASSESSMENT

DATA REQUIRED

**KEY DATA GATHERING
ACTIVITIES**

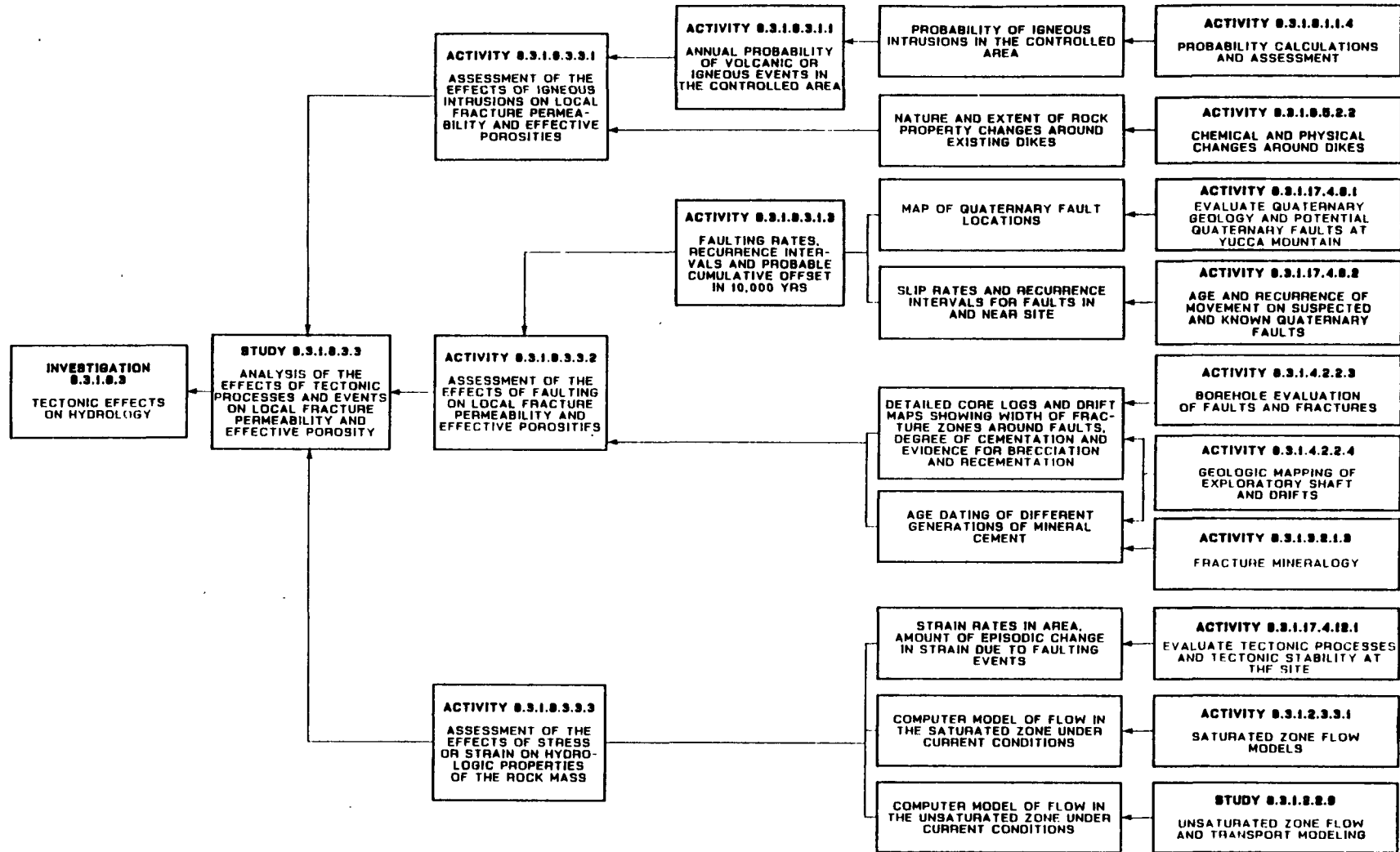

8.3.1.8-64

CONSULTATION DRAFT

8318-7-7/1087-VA

Figure 8.3.1.8-7. Logic diagram for Study 8.3.1.8.3.3 (effects of faulting on local fracture permeability and effective porosity).

CONSULTATION DRAFT

the probability of igneous events occurring in the larger area encompassing the controlled area and a buffer zone. Activity 8.3.1.8.3.1.2 will summarize the available data on the size and location of volcanic and igneous features that could occur in the area. This activity will also perform modeling studies to estimate the amount of change in flux rates that could occur as a result of an igneous event. The activity will then use this data and the data from Activity 8.3.1.8.3.1.1 to (1) provide an assessment of the possibility that significant changes could result from these initiating events and (2) prepare a report.

The third initiating event considered by Study 8.3.1.8.3.1 is the possibility that fault offset could affect average percolation flux rates. Effects to be considered include surface topographic changes such as the creation of a scarp that could create impoundments or divert drainage; and subsurface changes, such as the juxtaposition of units of different hydrologic properties or change in the dip of beds that could create perched aquifers or divert subsurface drainage toward the repository. Activity 8.3.1.8.3.1.3 will collect and summarize field data gathered by other activities and calculate slip rates, recurrence intervals and probable cumulative offset in 10,000 yr for faults in and near the controlled area. Activity 8.3.1.8.3.1.4 will perform hydrologic modeling studies to estimate the effect of faulting on flux rates. Activity 8.3.1.8.3.1.5 will use the data generated by the previous two activities to (1) generate an assessment of the effect of probable fault movement on flux rates that will satisfy parameters 5 to 7 and (2) prepare a report.

The fourth initiating event considers the possibility that folding processes could change the dip of beds in the repository area sufficiently to alter flux rates. This could occur where downward percolating waters are diverted laterally at the contact with a low permeability unit. The laterally moving waters at the contact could be diverted toward the repository by folding, thereby increasing repository flux rates. The fifth initiating event considers the possibility that rapid rates of area-wide uplift or subsidence could alter drainage patterns or gradients sufficiently to affect flux rates. These initiating events and parameters 8 and 9 associated with them will be addressed by Activities 8.3.1.8.3.1.6 and 8.3.1.8.3.1.7. Activity 8.3.1.8.3.1.6 will collect and summarize field data from other activities and calculate uplift and subsidence rates for the area including the site. Activity 8.3.1.8.3.1.7 will use these rates and rates of folding calculated by other activities to estimate the amount of folding uplift and subsidence expected in 10,000 yr. The activity will then (1) perform an assessment of the effect of these changes on average percolation flux rates using hydrologic modeling techniques and (2) summarize the assessment in a report.

Study 8.3.1.8.3.2 will analyze the possibility that tectonic processes and events could cause changes in the elevation of the water table or the potentiometric surface of confined aquifers. Rises in the water table would shorten the length of the unsaturated zone travel path and affect release rates. Such rises could also change the hydraulic gradient, alter the location of discharge points, or create perched aquifers in the area of the site. These effects could affect ground-water travel times or place locally saturated zones in close proximity to the waste. Four initiating events have been identified in connection with this study (Table 8.3.1.8-4).

CONSULTATION DRAFT

The first initiating event considers the possibility that igneous intrusions could affect water table elevations by creating barriers to flow such as a dike or creating thermally driven circulation systems that could cause water to rise to repository levels as the result of an intrusion or volcanic event. Activity 8.3.1.8.3.2.1 will collect and summarize data from other activities (Figure 8.3.1.8-6) on the dimensions and orientations of probable intrusions and the thermal effects around such intrusions. Hydrologic models of existing conditions at Yucca Mountain will then be used to estimate the magnitude of the changes that could result from igneous events. Activity 8.3.1.8.3.2.2 will take the results of this activity and combine them with data on the probability of such intrusions (Activity 8.3.1.8.3.1.1) to produce an assessment of the effects igneous intrusions would have on water table levels and will satisfy parameters 10 and 11. This activity will also prepare a report summarizing the results of the assessment.

The second initiating event considers the possibility that episodic movement on faults could result in variations in stress and strain levels in the rock mass that produce relatively short-lived fluctuations in water-table or potentiometric levels. If these fluctuations are great enough, these episodic changes could result in the periodic saturation of the repository horizon due to a general rise in the water table or water moving upward along a conduit such as a fault from a confined aquifer. Activity 8.3.1.8.3.2.3 will provide an assessment of the probability and magnitude of these effects and satisfy parameter 12. The activity will collect data on strain rates in the region and calculate the amount and nature of expected changes during a faulting event. Modeling studies will then be performed to analyze the amount of water table fluctuation that could be expected. The assessment will also include a consideration of the field evidence that significant water-table or potentiometric surface fluctuations have occurred in the past near Yucca Mountain and an evaluation of reports of water table occurring in connection with earthquakes at other locations. The activity will also prepare a report summarizing the assessment and the supporting data.

The third initiating event considers the possibility that folding, uplift, or subsidence could significantly change the position of the repository with respect to the water table in 10,000 yr. Activity 8.3.1.8.3.2.4 will review the data collected by other activities on the rates of folding, uplift, and subsidence in the area to provide an assessment of the probability of significant changes of this type and satisfy parameter 13.

The fourth initiating event considers the possibility that offset on faults could be great enough to juxtapose lithologic units of differing hydrologic properties and produce changes in ground-water flow that result in rises in the water table or the creation of perched aquifers. Activity 8.3.1.8.3.2.5 will conduct a hydrologic modeling study to estimate the amount of change in water-table levels that could be expected for a range of displacements. Activity 8.3.1.8.3.2.6 will combine this data with data on the probability of significant offsets (Activity 8.3.1.8.3.1.3) to produce an assessment of the probability of significant changes in water levels in a 10,000-yr period and satisfy parameters 14 and 15. The activity will also produce a report summarizing the data and the results of the assessment.

CONSULTATION DRAFT

Study 8.3.1.8.3.3 will consider the possibility that tectonic processes and events could alter the rock properties governing ground-water flow along significant travel paths. The initiating events are related to events or processes that could produce local changes in the saturated fracture permeability or fracture effective porosity. If such changes were to occur, they could result in the formation of barriers to ground-water flow or the creation of conduits to enhanced flow that could adversely affect the containment or transport rate of wastes. Three initiating events have been identified under this study (Table 8.3.1.8-5).

The first initiating event considers the possibility that an igneous intrusion could cause changes in the physical properties of the surrounding rocks. Activity 8.3.1.8.3.3.1 will collect and summarize data from the literature and field data gathering activities on the effects of the intrusion of dikes and sills in tuffs (Figure 8.3.1.8-7). This data will be combined with data on the probability of such intrusions in the controlled area (Activity 8.3.1.8.3.1.1) to produce an assessment that satisfies parameter 16 on the expected changes in local fracture permeability and fracture effective porosity resulting from igneous intrusions. The activity will result in a report summarizing the data and the results of the assessment.

The second initiating event considers the possibility that periodic offset on Quaternary faults in and near the controlled area could cause temporary changes in physical properties along the fault. These changes could result in the fault becoming a barrier to lateral ground-water flow or a conduit to vertical flow until mineralization or other processes return conditions to present values. Activity 8.3.1.8.3.3.2 will collect and summarize data from other activities on the width of fracturing around fault zones and evidence of significant fracturing and recementation along faults. These data will then be used to predict the variation in physical properties that can occur along faults through the faulting cycle. This information will then be combined with data on the probability of faulting events in the controlled area (Activity 8.3.1.8.3.1.3) to produce an assessment of the effects of the initiating event and satisfy parameters 17 and 18. The activity will also produce a report summarizing the data and the results of the assessment.

The third initiating event considers the possibility that episodic faulting, folding, uplift, or subsidence could result in cyclic changes in the physical properties of the rock mass because of changes in the stress and strain regime. Activity 8.3.1.8.3.3.3 will address this possibility and satisfy parameter 19 by summarizing data on strain rates in the area and modeling the changes in rock fracture permeability and porosity that could result. The activity will also produce a report summarizing the data and the results of the assessment.

CONSULTATION DRAFT

8.3.1.8.3.1 Study: Analysis of the effects of tectonic processes events on average percolation flux rates over the repository

This study will produce analyses and assessments of the probability and effects of tectonic initiating events that may result in changes in the average percolation flux rate at the top of the Topopah Spring welded unit.

8.3.1.8.3.1.1 Activity: Annual probability of volcanic or igneous events in the controlled area

Objectives

The objective of this activity is to calculate the annual probability of igneous and volcanic events within 0.5 km of the controlled area boundary.

Parameters

The parameters for this activity are

1. Annual probability of volcanic events within the controlled area.
2. Annual probability of significant igneous intrusion within 0.5 km of the controlled area boundary.

Description

This activity will take the data developed in Activity 8.3.1.8.1.1.4 on the probability of volcanic and igneous events penetrating the repository and expand that analysis to calculate probabilities for the area within 0.5 km of the controlled area boundary. Special attention will be paid to the possibility that the influence of structural controls on igneous activity may be different for this larger area than for the repository. The data supplied by this activity will be used by Activity 8.3.1.8.3.1.2 and in other studies in this investigation as part of the assessments of the effects of igneous activity in producing possible changes in hydrologic characteristics.

Methods and technical procedures

Activity 8.3.1.8.3.1.1 will only synthesize and compile data collected by other activities and will use the methods and technical procedures given in the following table.

CONSULTATION DRAFT

Method	Technical procedure		Date
	Number	Title	
Analysis of data	QP 3.1	Scientific investigation control and design control	20 Dec 86
Use of data from non-Project sources	NNWSI-SOP-03-03	Acceptance of data or data interpretation not developed under the NNWSI Project QA Plan	31 Jan 86

8.3.1.8.3.1.2 Activity: Assessment of the effects of igneous intrusions and volcanic events on flux rates

Objectives

The objective of this activity is to produce an assessment of the possibility that volcanic or igneous events could cause significant changes in the average percolation flux rate at the top of the Topopah Spring welded unit.

Parameters

The parameters for this activity are

1. The effects of a volcanic event on topography and average flux rates.
2. The effects of an igneous intrusion on average flux rates.

Description

This activity will collect and summarize data from the literature and other activities on the thickness and extent of lava flows and ash falls and the dimensions of Strombolian cones or hydrovolcanic maars that are possible in the site area. The data on these features will be reviewed to determine whether the appearance of such features could substantially alter average flux rates through changes in drainage and topography. This activity will also compile data and complete an estimate on the length, depth, and orientation of possible dikes and sills in the area. These data will then be used in computer modeling of the hydrologic flow system to determine the effect of intrusions on flux rates. The results of this analysis will be combined with the probability of such igneous events occurring calculated by Activity 8.3.1.8.3.1.1 into an assessment of the probability of significant changes in flux due to igneous events. The activity will prepare a report that will address the following topics:

1. A summary of the data used in the assessment.

CONSULTATION DRAFT

2. A discussion of the methods and models used in the analysis.
3. The results of the assessment.
4. A discussion of the assumptions and uncertainties in the data and the methods of analysis.

Methods and technical procedures

Activity 8.3.1.8.3.1.2 will only synthesize and compile data collected by other activities and will use the methods and technical procedures given in the following table.

Method	Technical procedure		
	Number	Title	Date
Analysis of data	QP 3.1	Scientific investigation control and design control	20 Dec 86
Use of data from non-Project sources	NNWSI-SOP-03-03	Acceptance of data or data interpretation not developed under the NNWSI Project QA Plan	31 Jan 86
Validation of computer models	NNWSI-SOP-03-02	Software quality assurance	28 Feb 86
	QP 3.2	Use and control of computer programs	20 Dec 86

8.3.1.8.3.1.3 Activity: Faulting rates, recurrence intervals, and probable cumulative offset in 10,000 yr

Objectives

The objective of this activity is to provide estimates of the slip rates, recurrence intervals, and probable cumulative offset in 10,000 yr on Quaternary faults in and near the controlled area.

Parameters

The parameters for this activity are

1. Location and spacing of Quaternary faults in and near the controlled area.
2. Slip rates on Quaternary faults in and near the controlled area.

CONSULTATION DRAFT

3. Recurrence intervals on Quaternary faults in and near the controlled area.
4. Present dip of tuff beds at Yucca Mountain in and near the controlled area.

Description

This activity will collect and summarize data from a number of field data gathering activities and synthesize that data to provide estimates of the parameters listed above. The data to be reviewed and summarized include detailed bedrock geologic mapping, mapping of Quaternary deposits and faults, detailed structure contour maps, and logs of trenches across Quaternary faults. Figure 8.3.1.8-5 indicates the key data gathering activities that will be supplying this data. The bedrock and Quaternary geologic maps and the structure contour maps will be used to define the location, length, and orientation of Quaternary faults in the area of the repository. Data on the amount and age of displacement from trench logs, detailed structure contour maps, and detailed geologic maps will be used to calculate slip rates and recurrence intervals. Slip rates for time intervals extending from the present to the Miocene will be calculated in order to determine Quaternary slip rates and to analyze the changes that have occurred in slip rates over the last 15 million yr. The detailed structure contour maps will also be used to determine the range of possible down-dip fault geometries that need to be considered in the depth range that is significant in calculating the effects of faulting on hydrologic properties. These structure contour maps will incorporate data obtained from the geophysical, drilling, and mapping activities. The information generated by this activity will be used by Activity 8.3.1.8.3.1.5 and the other studies in this investigation to satisfy the performance parameters.

Methods and technical procedures

Activity 8.3.1.8.3.1.3 will only synthesize and compile data collected by other activities and will use the methods and technical procedures given in the following table.

Method	Technical procedure		Date
	Number	Title	
Analysis of data	QP 3.1	Scientific investigation control and design control	20 Dec 86
Use of data from non-Project sources	NNWSI-SOP-03-03	Acceptance of data or data interpretation not developed under the NNWSI Project QA Plan	31 Jan 86

CONSULTATION DRAFT

8.3.1.8.3.1.4 Activity: Effects of faulting on average flux rates

Objectives

The objective of this activity is to estimate the effects that the creation of scarps, the diversion of drainage, the change in the dip of beds, or the juxtaposition of beds due to fault offset would have on average percolation flux at the top of the Topopah Spring welded unit.

Parameters

The parameters for this activity are models of average flux rate change resulting from a range of faulting conditions.

Description

This activity will generate models that can be used by Activity 8.3.1.8.3.1.5 to analyze the probability of significant changes in average percolation flux rates due to fault activity. These models will be based on the models of present conditions that control flux rates in Study 8.3.1.2.2.9. This activity will consider the perturbations to current conditions resulting from the offset or tilting of beds and changes to topography that a faulting event may cause. Various amounts and locations of offset will be modeled to determine the point at which fault offset could become a significant factor in controlling flux rates.

Methods and technical procedures

Activity 8.3.1.8.3.1.4 will only synthesize and compile data collected by other activities and will use the methods and technical procedures given in the following table.

Method	Technical procedure		Date
	Number	Title	
Analysis of data	QP 3.1	Scientific investigation control and design control	20 Dec 86
Use of data from non-Project sources	NNWSI-SOP-03-03	Acceptance of data or data interpretation not developed under the NNWSI Project QA Plan	31 Jan 86
Validation of computer models	NNWSI-SOP-03-02	Software quality assurance	28 Feb 86
	QP 3.2	Use and control of computer programs	20 Dec 86

CONSULTATION DRAFT

8.3.1.8.3.1.5 Activity: Assessment of the effects of faulting on flux rates

Objectives

The objective of this activity is to provide an assessment of the probability that average percolation flux rates at the top of the Topopah Spring welded unit at Yucca Mountain would be significantly affected by future fault activity.

Parameters

The parameters for this activity are

1. Probability of offset more than 2 m on faults in the controlled area in 10,000 yr.
2. Probability of changing dip by greater than 2 degrees in 10,000 yr.
3. Effect of faulting on average flux rates.

Description

This activity will use the data and models generated by the two previous activities to prepare an assessment of the probability that faulting will significantly affect flux rates at Yucca Mountain. The data on slip rates and recurrence intervals will be used to calculate the probability that faulting events will occur during a 10,000-yr period. These data will also be used to calculate the amount of expected offset in single events, the cumulative offset in 10,000 yr, and the probability of significantly large offsets (>2 m) occurring. The data on the present dips at the site, location and spacing of Quaternary faults, and slip rates will be analyzed to estimate the amount of change in dip that could result from fault displacement in 10,000 yr and the probability of significant changes (>2°) occurring. The models from Activity 8.3.1.8.3.1.4 will then be used to estimate the effects of expected faulting conditions on flux rates. A report that contains the results of the assessment will be prepared that includes the following topics:

1. A summary of the data and calculations used in the assessment.
2. A discussion of the modeling techniques used and their results.
3. The results of the assessment.
4. An analysis of the assumptions and uncertainties in the data and the assessment.

Methods and technical procedures

Activity 8.3.1.8.3.1.5 will only synthesize and compile data collected by other activities and will use the methods and technical procedures given in the following table.

CONSULTATION DRAFT

Method	Technical procedure		Date
	Number	Title	
Analysis of data	QP 3.1	Scientific investigation control and design control	20 Dec 86
Use of data from non-Project sources	NNWSI-SOP-03-03	Acceptance of data or data interpretation not developed under the NNWSI Project QA Plan	31 Jan 86

8.3.1.8.3.1.6 Activity: Uplift rates in the controlled area

Objectives

The objective of this activity is to calculate the rate of uplift or subsidence in and around the controlled area.

Parameters

The parameter for this activity is the uplift or subsidence rates in and around the controlled area.

Description

This activity will compile and summarize data collected by other field data-gathering activities that can be used to calculate the rates of uplift and subsidence affecting the controlled area. Data such as geodetic leveling and the geomorphic and geologic indicators of Quaternary uplift and subsidence will be used in the calculation. The rates estimated by this activity will be used by Activity 8.3.1.8.3.1.7 and the other studies in this investigation to assess the effect of uplift and subsidence on hydrologic conditions.

Methods and technical procedures

Activity 8.3.1.8.3.1.6 will only synthesize and compile data collected by other activities and will use the methods and technical procedures given in the following table.

CONSULTATION DRAFT

Method	Technical procedure		Date
	Number	Title	
Analysis of data	QP 3.1	Scientific investigation control and design control	20 Dec 86
Use of data from non-Project sources	NNWSI-SOP-03-03	Acceptance of data or data interpretation not developed under the NNWSI Project QA Plan	31 Jan 86

8.3.1.8.3.1.7 Activity: Assessment of the effects of folding, uplift, and subsidence on flux rates

Objectives

The objective of this activity is to assess the probability that folding, uplift, or subsidence will significantly alter average percolation flux rates at the top of the Topopah Spring welded unit over the repository.

Parameters

The parameters for this activity are

1. The probability of dip changing by greater than 2 degrees in 10,000 yr by folding.
2. The probability of exceeding 30 m of altitude change in 10,000 yr.

Description

This activity will use the data generated by Activities 8.3.1.8.2.1.6 and 8.3.1.8.3.1.6 to calculate (1) the expected amount of change in dip and altitude in 10,000 yr and (2) the probability that significant changes would occur. If significant changes are considered credible, models based on the present conditions controlling flux rates in Study 8.3.1.2.2.5 will be developed to consider the perturbations to current conditions resulting from the tilting of beds and changes to topography that could occur. A report will be prepared that includes the following topics:

1. A summary of the data and calculations used in the assessment.
2. A discussion of the modeling techniques used and their results.
3. The results of the assessment.
4. An analysis of the assumptions and uncertainties in the data and the assessment.

CONSULTATION DRAFT

Methods and technical procedures

Activity 8.3.1.8.3.1.7 will only synthesize and compile data collected by other activities and will use the method and technical procedures given in the following table.

Method	Technical procedure		Date
	Number	Title	
Analysis of data	QP 3.1	Scientific investigation control and design control	20 Dec 86
Use of data from non-Project sources	NNWSI-SOP-03-03	Acceptance of data or data interpretation not developed under the NNWSI Project QA Plan	31 Jan 86
Validation of computer models	NNWSI-SOP-03-02	Software quality assurance	28 Feb 86
	QP 3.2	Use and control of computer programs	20 Dec 86

8.3.1.8.3.2 Study: Analysis of the effect of tectonic processes and events on changes in water-table elevation

This study will produce analyses and assessments of the probability that tectonic initiating events could result in significant changes in the elevation of the water table or potentiometric surface, changes in the hydraulic gradient, the creation of discharge points in the controlled area, or the creation of perched aquifers in the controlled area.

8.3.1.8.3.2.1 Activity: Thermal and barrier-to-flow effects of igneous intrusions on water-table elevation

Objectives

The objective of this activity is to model the effects that dikes or other intrusions would have on water-table elevation due either to the barrier to flow created by intrusion or the thermal pulse produced by the intrusion.

Parameters

The parameters for this activity are models for predicting the effects of igneous intrusions on water-table levels.

CONSULTATION DRAFT

Description

This activity will produce models for use in assessing the effects of igneous intrusions on water-table levels. These models will be based on the models of present ground-water flow developed in Activity 8.3.1.2.3.3.1. The first part of the modeling activity will consider the perturbations to current conditions resulting from the barriers to flow that intrusive features such as a dike might produce. Dikes of various sizes and orientations will be modeled to estimate the range of effects and determine at what point igneous intrusions would begin to produce significant changes.

The second part of the modeling activity will consider the thermal effects of an intrusion on water levels. As discussed in Sections 1.3.2.1.2 and 1.5.1, basaltic volcanism is considered to be the only credible intrusive scenario during the postclosure period. This type of activity is characterized by the intrusion of dikes from magma bodies with depths of 20 to 30 km. Therefore, the intrusion of a dike is considered to be the only credible process by which changes in the thermal characteristics of the site could occur. Published methods (e.g., Link et al., 1982) will be used to calculate the magnitude and extent of thermal changes around a dike. The results of Activity 8.3.1.8.1.2.3 will also be reviewed to determine if there are any indications of magma bodies in the vicinity of the site with the potential for significant movement in 10,000 yr that could produce significant changes in the thermal gradient. Models will then be generated that predict the effects of thermal changes on water levels. These models will be used by Activity 8.3.1.8.3.2.2 in the assessment of the probability that igneous intrusions will cause significant changes in water-table levels.

Methods and technical procedures

Activity 8.3.1.8.3.2.1 will only synthesize and compile data collected by other activities and will use the methods and technical procedures given in the following table.

Method	Technical procedure		
	Number	Title	Date
Analysis of data	QP 3.1	Scientific investigation control and design control	20 Dec 86
Use of data from non-Project sources	NNWSI-SOP-03-03	Acceptance of data or data interpretation not developed under the NNWSI Project QA Plan	31 Jan 86
Validation of computer models	NNWSI-SOP-03-02	Software quality assurance	28 Feb 86
	QP 3.2	Use and control of computer programs	20 Dec 86

8.3.1.8.3.2.2 Activity: Assessment of the effects of igneous intrusions on water-table elevations

Objectives

The objective of this activity is to produce an assessment of the probability that igneous intrusions will cause (1) significant changes in the elevation of the water table or potentiometric surface, (2) changes in the hydraulic gradient, (3) the creation of discharge points in the controlled area, or (4) the creation of perched aquifers in the controlled area.

Parameters

The parameters for this activity are

1. Barrier-to-flow effects of igneous intrusions on water-table levels and hydraulic gradients.
2. Thermal effects of igneous intrusions on water-table levels and hydraulic gradients.

Description

This activity will use the data in Activity 8.3.1.8.3.1.1 to estimate the probability of an igneous event occurring in or near the controlled area. It will also collect and summarize data from other data gathering activities (Figure 8.3.1.8-6) to estimate the length, thickness, and orientation of possible future intrusions. This data will then be used with models developed in Activity 8.3.1.8.3.2.1 to estimate the effects of expected intrusions. This activity will also review the available literature for evidence of water-table changes during volcanic events in other parts of the world that are analogous to the types of events that might occur in the vicinity of the site. All of this information will then be integrated to produce an assessment of the probability that igneous intrusions will cause significant changes in the elevation of the water table or potentiometric surface, changes in the hydraulic gradient, the creation of discharge points in the controlled area, or the creation of perched aquifers in the controlled area. The results will be summarized in a report that will include the following topics:

1. A summary of the data and calculations used in the assessment.
2. A discussion of the modeling techniques used and their results.
3. The results of the assessment.
4. An analysis of the assumptions and uncertainties in the data and the assessment.

Methods and technical procedures

Activity 8.3.1.8.3.2.2 will only synthesize and compile data collected by other activities and will use the methods and technical procedures given in the following table.

CONSULTATION DRAFT

Method	Technical procedure		Date
	Number	Title	
Analysis of data	QP 3.1	Scientific investigation control and design control	20 Dec 86
Use of data from non-Project sources	NNWSI-SOP-03-03	Acceptance of data or data interpretation not developed under the NNWSI Project QA Plan	31 Jan 86

8.3.1.8.3.2.3 Activity: Assessment of the effect of strain changes on water-table elevation

Objectives

The objective of this activity is to estimate the probability that changes in stress or strain resulting from faulting events could significantly alter water-table levels or potentiometric surfaces in and around the controlled area.

Parameters

The parameter for this activity is the probability that strain-induced changes will increase the water-table level or the level of potentiometric surfaces to more than 850 m mean sea level (MSL).

Description

This activity will use the models of present flow in the saturated zone from Activity 8.3.1.2.3.3.1 to develop a model to predict the effects on the level of the water table or potentiometric surfaces in the vicinity of the site of changes in the present level of stress or strain caused by a faulting event. Data on the magnitude of such changes in stress and strain will be estimated using theoretical calculations and data from Activity 8.3.1.17.4.12.1. The model will be used to estimate the effects of anticipated strain changes and to determine the point at which such strain changes could become significant.

This activity will also compile and analyze data on the effects of historic earthquakes on water-table elevations. Earthquakes that have induced water-table fluctuations will be studied to determine the type of material in which changes occurred (rock or alluvium), the amount and duration of changes, and the local geologic and ground-water conditions that may influence whether or not significant changes occur. The results of this analysis will be compared with conditions present at the site to estimate whether any of these occurrences represent analogs of possible future site behavior.

CONSULTATION DRAFT

Field evidence from the site will be reviewed to determine if there is any evidence of past water-table fluctuations that may be related to tectonic events. For example, the results of Activity 8.3.1.5.2.2.6 will be reviewed to determine whether or not the calcite-silica deposits that are found along some faults are episodic spring deposits that may be related to fluctuations of the water table or potentiometric surface or whether the deposits are the result of surface pedogenic processes.

The results of these studies will then be incorporated into an assessment evaluating the possibility of significant water-table fluctuations due to strain changes. The results of the assessment will be summarized in a report that will include the following topics:

1. A summary of the data and calculations used in the assessment.
2. A discussion of the modeling techniques used and their results.
3. The results of the assessment.
4. An analysis of the assumptions and uncertainties in the data and the assessment.

Methods and technical procedures

Activity 8.3.1.8.3.2.3 will only synthesize and compile data collected by other activities and will use the methods and technical procedures given in the following table.

Method	Technical procedure		Date
	Number	Title	
Analysis of data	QP 3.1	Scientific investigation control and design control	20 Dec 86
Use of data from non-Project sources	NNWSI-SOP-03-03	Acceptance of data or data interpretation not developed under the NNWSI Project QA Plan	31 Jan 86
Validation of computer models	NNWSI-SOP-03-02	Software quality assurance	28 Feb 86
	QP 3.2	Use and control of computer programs	20 Dec 86

CONSULTATION DRAFT

8.3.1.8.3.2.4 Activity: Assessment of the effect of folding, uplift, or subsidence on water-table elevation

Objectives

The objective of this activity is to provide an assessment of the probability that folding, uplift, or subsidence could change the elevation of the repository with respect to the level of the water table sufficiently to significantly alter the length of the unsaturated zone travel path.

Parameters

The parameter for this activity is the probability that the repository will be lowered by 100 m through the action of folding, uplift, or subsidence in 10,000 yr.

Description

This activity will use the data generated by Activities 8.3.1.8.2.1.6 and 8.3.1.8.3.1.6 to calculate the expected amount of change in the elevation of the repository horizon over 10,000 yr caused by folding, uplift, or subsidence. This activity will also assess the probability that changes of a significant nature would occur. The results of the assessment will be summarized in a report that will include the following topics:

1. A summary of the data and calculations used in the assessment.
2. The results of the assessment.
3. An analysis of the assumptions and uncertainties in the data and the assessment.

Methods and technical procedures

Activity 8.3.1.8.3.2.4 will only synthesize and compile data collected by other activities and will use the methods and technical procedures given in the following table.

Method	Technical procedure		
	Number	Title	Date
Analysis of data	QP 3.1	Scientific investigation control and design control	20 Dec 86
Use of data from non-Project sources	NNWSI-SOP-03-03	Acceptance of data or data interpretation not developed under the NNWSI Project QA Plan	31 Jan 86

CONSULTATION DRAFT

8.3.1.8.3.2.5 Activity: Effects of faulting on water-table elevation

Objectives

The objective of this activity is to produce models to analyze the potential for fault offset to change the elevation of the water table or potentiometric surface, change the hydraulic gradient, create discharge points in the controlled area, or create perched aquifers in the controlled area.

Parameters

The parameters for this activity are the models for predicting the effects of faulting on water-table levels.

Description

This activity will use the models of present flow in the saturated zone from Activity 8.3.1.2.3.3.1 and unsaturated zone from Study 8.3.1.2.2.9 to develop a model to predict the effects of a faulting event on the level of the water table or the creation of a perched aquifer. The effects of a variety of fault offsets, orientations, down-dip geometries, and locations will be calculated to estimate the point at which faulting could become significant. The models produced by this activity will be used by Activity 8.3.1.8.3.2.6 in the assessment of the effects of faulting on water-table levels.

Methods and technical procedures

Activity 8.3.1.8.3.2.5 will only synthesize and compile data collected by other activities and will use the methods and technical procedures given in the following table.

Method	Technical procedure		Date
	Number	Title	
Analysis of data	QP 3.1	Scientific investigation control and design control	20 Dec 86
Use of data from non-Project sources	NNWSI-SOP-03-03	Acceptance of data or data interpretation not developed under the NNWSI Project QA Plan	31 Jan 86
Validation of computer models	NNWSI-SOP-03-02	Software quality assurance	28 Feb 86
	QP 3.2	Use and control of computer programs	20 Dec 86

CONSULTATION DRAFT

8.3.1.8.3.2.6 Activity: Assessment of the effect of faulting on water-table elevation

Objectives

The objective of this activity is to prepare an assessment of the probability that fault offset will result in significant changes in the elevation of the water table or potentiometric surface, changes in the hydraulic gradient, the creation of discharge points in the controlled area, the creation of perched aquifers in the controlled area in 10,000 yr.

Parameters

The parameters for this activity are

1. Probability of total offsets more than 2.0 m in 10,000 yr on faults within 0.5 km of the controlled area boundary.
2. Effects of fault offset on water-table levels and hydraulic gradient.

Description

This activity will use the data on slip rates and recurrence intervals on Quaternary faults in and near the controlled area from Activity 8.3.1.8.3.1.4 to calculate the expected cumulative displacement in 10,000 yr and the probability of significant cumulative offset (>2 m) occurring on any fault. These data and data on the length and location of Quaternary faults will then be used with the models produced in Activity 8.3.1.8.3.2.5 to estimate the changes that would be produced under anticipated and unanticipated conditions.

This activity will also consider the results of Activity 8.3.1.8.3.2.3 on the evidence of possible past changes in water-table levels in the site area and the effects of faulting during historic earthquakes on water-table levels. The above data will then be incorporated into an assessment of the probability of significant fault offsets occurring in 10,000 yr and the effects of fault offset on water-table elevation. The assessment will include an analysis of possible changes in the elevation of the water table or potentiometric surface, changes in the hydraulic gradient, the creation of discharge points in the controlled area, the creation of perched aquifers based on the results of the modeling and probability calculations. The results of the assessment will be summarized in a report that will include the following topics:

1. A summary of the data and calculations used in the assessment.
2. A discussion of the modeling techniques used and their results.
3. The results of the assessment.
4. An analysis of the assumptions and uncertainties in the data and the assessment.

CONSULTATION DRAFT

Methods and technical procedures

Activity 8.3.1.8.3.2.6 will only synthesize and compile data collected by other activities and will use the methods and technical procedures given in the following table.

Method	Technical procedure		Date
	Number	Title	
Analysis of data	QP 3.1	Scientific investigation control and design control	20 Dec 86
Use of data from non-Project sources	NNWSI-SOP-03-03	Acceptance of data or data interpretation not developed under the NNWSI Project QA Plan	31 Jan 86

8.3.1.8.3.3 Study: Analysis of the effects of tectonic processes and events on local fracture permeability and effective porosity

The activities in this study address tectonic initiating events and processes that could cause local changes in saturated fracture permeability or fracture effective porosity.

8.3.1.8.3.3.1 Activity: Assessment of the effects of igneous intrusions on local fracture permeability and effective porosities

Objectives

The objective of this activity is to assess the possibility that igneous intrusions, such as dikes or sills, could cause changes in the hydrologic flow properties of the surrounding rocks.

Parameters

The parameters for this activity are the effects of igneous intrusions on local fracture permeabilities and effective porosities.

Description

This activity will use the results of Activity 8.3.1.8.3.1.1 on the probability of igneous intrusions in and near the controlled area and Activity 8.3.1.8.5.2.3 that measures the nature and extent of physical changes around intrusions in tuff. These data will be reviewed, summarized, and combined into an assessment of the probability that igneous intrusions could result in significant changes in local saturated fracture permeability and

CONSULTATION DRAFT

fracture effective porosity. The assessment will also include a consideration of how probable changes in physical properties could affect the movement of gaseous decay products in the unsaturated zone. The assessment will be summarized in a report that includes the following topics:

1. A summary of the data and calculations used in the assessment.
2. The results of the assessment.
3. An analysis of the assumptions and uncertainties in the data and the assessment.

Methods and technical procedures

Activity 8.3.1.8.3.3.1 will only synthesize and compile data collected by other activities and will use the methods and technical procedures given in the following table.

Method	Technical procedure		Date
	Number	Title	
Analysis of data	QP 3.1	Scientific investigation control and design control	20 Dec 86
Use of data from non-Project sources	NNWSI-SOP-03-03	Acceptance of data or data interpretation not developed under the NNWSI Project QA Plan	31 Jan 86

8.3.1.8.3.3.2 Activity: Assessment of the effects of faulting on local fracture permeability and effective porosities

Objectives

The objective of this activity is to assess the probability that movement on faults could result in significant local changes in saturated fracture permeability and fracture effective porosity along the fault that could affect the regional ground water flow system.

Parameters

The parameters for this activity are

1. The annual probability of faulting events on Quaternary faults within 0.5 km of the controlled area boundary.
2. The effects of fault motion on local fracture permeabilities and effective porosities.

CONSULTATION DRAFT

Description

This activity will determine the nature of faulting and calculate the annual probability of faulting in and near the controlled area using the data on slip rates, recurrence intervals, down-dip geometry, and number of faults from Activity 8.3.1.8.3.1.3. Data on the width of fracture zones around faults, evidence of the possible episodic brecciation and recementation of mineral fillings along fault zones, and the age and nature of the mineral fillings will be collected and summarized after reviewing the core logs, the geologic mapping of shaft and drifts, and fracture mineralogy studies collected by other field data gathering activities (Figure 8.3.1.8-7) near Quaternary faults. These data will be analyzed to determine the nature, extent, and duration of changes in physical properties that could occur along faults in the vicinity of the site. An assessment of the probability of significant changes will then be produced by integrating all the above results. The assessment will also include a consideration of how the probable changes in physical properties could affect the movement of gaseous decay products in the unsaturated zone. The assessment will be summarized in a report that includes the following topics:

1. A summary of the data and calculations used in the assessment.
2. The results of the assessment.
3. An analysis of the assumptions and uncertainties in the data and the assessment.

Methods and technical procedures

Activity 8.3.1.8.3.3.2 will only synthesize and compile data collected by other activities and will use the methods and technical procedures given in the following table.

Method	Technical procedure		
	Number	Title	Date
Analysis of data	QP 3.1	Scientific investigation control and design control	20 Dec 86
Use of data from non-Project sources	NNWSI-SOP-03-03	Acceptance of data or data interpretation not developed under the NNWSI Project QA Plan	31 Jan 86

CONSULTATION DRAFT

8.3.1.8.3.3.3 Activity: Assessment of the effects of stress or strain on hydrologic properties of the rock mass

Objectives

The objective of this activity is to assess the probability that changes in stress or strain conditions around the site caused by a tectonic event could result in significant changes in the saturated fracture permeability and fracture effective porosity of the rock mass.

Parameters

The parameters for this activity are the effects of changes of stress or strain on hydrologic properties of the rock mass.

Description

This activity will use theoretical calculations and the data from Activity 8.3.1.17.4.12.1 to estimate the magnitude of stress and strain changes through the faulting cycle for the site area. Modeling studies will then be performed to estimate the effect that these changes might have on hydrologic properties. These results will then be combined with the probability of faulting events in and near the controlled area to calculate the probability that significant changes in the physical properties of the rock mass could occur. The assessment will also include a consideration of how the probable changes in physical properties could affect the movement of gaseous decay products in the unsaturated zone. The assessment will be summarized in a report that includes the following topics:

1. A summary of the data used in the assessment.
2. A summary and discussion of the models used in the assessment and their results.
3. The results of the assessment.
4. An analysis of the assumptions and uncertainties in the data and the assessment.

Methods and technical procedures

Activity 8.3.1.8.3.3.3 will only synthesize and compile data collected by other activities and will use the methods and technical procedures given in the following table.

CONSULTATION DRAFT

Method	Technical procedure		Date
	Number	Title	
Analysis of data	QP 3.1	Scientific investigation control and design control	20 Dec 86
Use of data from non-Project sources	NNWSI-SOP-03-03	Acceptance of data or data interpretation not developed under the NNWSI Project QA Plan	31 Jan 86
Validation of computer models	NNWSI-SOP-03-02	Software quality assurance	28 Feb 86
	QP 3.2	Use and control of computer programs	20 Dec 86

8.3.1.8.3.4 Application of results

The information derived from the studies and activities described above will be used in the following issues and investigations.

<u>Issue or investigation</u>	<u>Subject</u>
1.1	Total system performance (Section 8.3.5.13)
1.8	NRC siting criteria (Section 8.3.5.17)
1.9	Higher level findings--postclosure (Section 8.3.5.18)
8.3.1.8.4	Tectonic effects on geochemistry

8.3.1.8.3.5 Schedule and milestones

This investigation addresses postclosure tectonic effects on hydrology and contains three out-year studies: 8.3.1.8.3.1 (analysis of the effects of tectonic processes and events on average percolation flux rates over the repository), 8.3.1.8.3.2 (analysis of the effect of tectonic processes and events on changes in water-table elevation), and 8.3.1.8.3.3 (analysis of the effects of tectonic processes and events on local fracture permeability and effective porosity). In the figure that follows, the schedule information for these studies is presented in the form of timelines. The timelines extend from implementation of the approved study plans to the issuance of the final products associated with the studies. Summary schedule and milestone information for this investigation can be found in Section 8.5.1.1.

CONSULTATION DRAFT

The activities of this entire investigation are planned to progress in parallel with performance and design activities in an iterative fashion. The results of these studies will be used toward the resolution of Issue 1.1 (total system performance) and to support advanced conceptual and license application designs.

Completion of the studies in this investigation are constrained by the availability of data from several other investigations. Study 8.3.1.8.3.1 requires the following data: the probability and effects of volcanic eruptions from Investigation 8.3.1.8.1, computer models of flow in the unsaturated zone from Investigation 8.3.1.2.2; fault location, spacing, displacement and recurrence from Investigation 8.3.1.17.4; and detailed geologic and structure contour maps from Investigation 8.3.1.4.2.

Completion of Study 8.3.1.8.3.2 is constrained by the following information: the probability and effects of volcanic eruptions from Investigation 8.3.1.8.1; computer models of flow in the unsaturated zone from Investigation 8.3.1.2.2; fault location, spacing, displacement and recurrence from Investigation 8.3.1.17.4; detailed geologic and structure contour maps from Investigation 8.3.1.4.2; origin of calcite-silica deposits from Investigation 8.3.1.5.2; origin, nature and age of vein fillings and rock alteration from Investigation 8.3.1.3.2; computer models of flow in the saturated zone from Investigation 8.3.1.2.3; expected amounts of rupture length and offset during single faulting events from Investigation 8.3.1.17.3; and detailed mapping of the exploratory shaft and drifts from Investigation 8.3.1.4.2.

Completion of Study 8.3.1.8.3.3 depends on the availability of the following information: the probability and effects of volcanic eruptions from Investigation 8.3.1.8.1; computer models of flow in the unsaturated zone from Investigation 8.3.1.2.2; fault location, spacing, displacement and recurrence of faulting and area strain rates from Investigation 8.3.1.17.4; computer models of flow in the saturated zone from Investigation 8.3.1.2.3; evaluation of faults and fractures mapped or logged in boreholes or the exploratory shaft and drifts from Investigation 8.3.1.4.2; age dating of different generations of mineral fillings in faults and fractures from Investigation 8.3.1.3.2; and rock property changes around dikes and sills from Investigation 8.3.1.8.5.

The study numbers and titles corresponding to the timelines are shown on the left of the following figure. The points shown on the timelines represent major events or important milestones associated with the study. Solid lines represent study durations, and dashed lines show interfaces. The data input and output at the interfaces are shown by circles.

CONSULTATION DRAFT

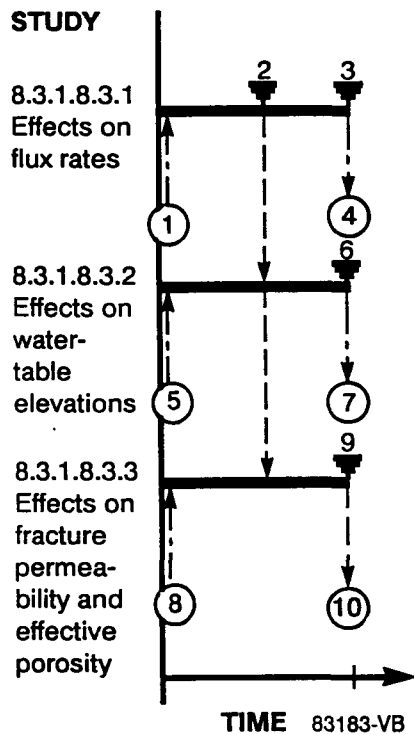

The points on the timeline and the data input and output at the interfaces are described in the following table:

<u>Point number</u>	<u>Description</u>
1	Data input from Investigations 8.3.1.8.1 (volcanic activity), 8.3.1.2.2 (site unsaturated zone hydrologic system), 8.3.1.17.4 (preclosure tectonics data collection analysis), and 8.3.1.4.2 (geologic framework).
2	Milestone Z297. Report available on faulting rates, recurrence intervals, and probable cumulative offset in 10,000 yr available for use by Studies 8.3.1.8.3.1, 8.3.1.8.3.2, and 8.3.1.8.3.3.
3	Milestones Z384, Z383, and Z393. A series of reports is available for use by Issue 1.1 (total system performance) assessing the effects of volcanism, faulting, folding, uplift and subsidence on flux rates.
4	Data input to Issue 1.1 from reports assessing the effects of volcanism faulting, folding, uplift and subsidence on flux rates.

CONSULTATION DRAFT

<u>Point number</u>	<u>Description</u>
5	Data input from Investigations 8.3.1.5.2 (climate effects on hydrology), 8.3.1.3.2 (mineralogy, petrology, and rock chemistry), 8.3.1.2.3 (site saturated zone hydrologic system), 8.3.1.17.3 (vibratory ground motion), 8.3.1.8.1, 8.3.1.2.2, 8.3.1.17.4, and 8.3.1.4.2.
6	Milestones Z385, Z386, Z387, and Z388. A series of reports available for use by Issue 1.1 assessing the effects of igneous intrusions, strain changes, faulting, folding, uplift and subsidence on water-table elevations.
7	Data input to Issue 1.1 from reports assessing the effects of igneous intrusions, strain changes, faulting, folding, uplift and subsidence on water-table elevations.
8	Data input from Investigations 8.3.1.8.1 (volcanic activity), 8.3.1.8.5 (postclosure tectonics data collection and analysis), 8.3.1.17.4 (preclosure tectonics data collection analysis), 8.3.1.4.2 (geologic framework), 8.3.1.3.2 (mineralogy, petrology, and rock chemistry), 8.3.1.2.2 (site unsaturated zone hydrologic system), and 8.3.1.2.3 (site saturated zone hydrologic system).
9	Milestones Z389, Z390, Z391. A series of reports available for use by Issue 1.1 assessing the effects of igneous intrusions, faulting and stress and strain changes on local fracture permeability and effective porosity.
10	Data input to Issue 1.1 from reports assessing the effects of igneous intrusions, faulting, and stress and strain changes on local fracture permeability and effective porosity.

8.3.1.8.4 Investigation: Studies to provide information required on changes in rock geochemical properties resulting from tectonic processes

Technical basis for obtaining the information

Links to the technical data chapters and applicable support documents

The following sections of the SCP data chapters provide a technical summary of existing data relevant to this investigation:

<u>SCP section</u>	<u>Subject</u>
1.3.2.1	Volcanic history
1.3.2.2	Structural history
1.5.1.2	Basaltic volcanism

CONSULTATION DRAFT

<u>SCP section</u>	<u>Subject</u>
1.5.2	Faulting
4.1.3.7	Geochemical retardation of the host rock and surrounding units--anticipated conditions
4.1.3.8	Geochemical retardation of the host rock and surrounding units--unanticipated conditions
4.4.2	Potential effects of natural changes

Parameters

The following performance parameters will be measured or calculated as a result of the site studies planned as part of this investigation:

1. Effects of igneous intrusions on local distribution coefficients.
2. Degree of mineralogic change in fault zones in 10,000 yr.
3. Effects of fault offset on travel pathway.
4. Degree of mineralogic change in the controlled area resulting from changes in water-table level or flow paths due to tectonic processes in 10,000 yr.

Purpose and objectives of the investigation

The four performance parameters listed in the previous section have been identified by Issue 1.1 (Section 8.3.5.13, total system performance, and Table 8.3.1.8-6) to address the possibility that tectonic processes and events could produce significant changes in the geochemical properties of the rocks of the controlled area that control the rate of radionuclide movement (distribution coefficients (K_d s)). The study and activities in this investigation will address these requirements by providing assessments of the probability that the tectonic initiating events that have been recognized by Issue 1.1 could significantly alter distribution coefficients. These results will be used by Issue 1.1 to analyze total system performance of the repository in limiting radionuclide releases to the accessible environment. The initiating events considered in this investigation probably will have no significant impact on repository performance because of the very low rate at which mineral alteration occurs in the site area (see Section 4.1.1.4). It is anticipated that the data to be gathered in the geochemistry program (Section 8.3.1.3) to address other concerns will provide the data necessary to evaluate the rate of geochemical change. The level of effort for the activities related to these initiating events is therefore anticipated to be low and to consist primarily of organizing and presenting the data collected in other programs to provide the basis for evaluating the credibility of the initiating events in performance assessment activities.

This investigation will also provide data on the nature of tectonic processes operating at the site for use by Issue 1.8 (Section 8.3.5.17, NRC siting criteria) in its analysis of favorable and potentially adverse

CONSULTATION DRAFT

conditions. The specific conditions addressed by this investigation are listed on Table 8.3.1.8-6.

Technical rationale for the investigation

The flow of data and interconnections between activities in the single study of this investigation are shown on Figure 8.3.1.8-8. The first tectonic initiating event considered in this investigation is the possibility that an igneous intrusion could alter the mineralogy of the surrounding host rocks. Activity 8.3.1.8.4.1.1 will provide an assessment of this initiating event and satisfy parameter 1 by considering (1) the probability of an igneous intrusion occurring in the controlled area and (2) the extent and nature of mineral changes that have been found to occur around dikes and sills in tuffs during field studies. The activity will combine these data in an assessment of the probability that significant changes would occur.

The second initiating event considers the possibility that offset on a fault could result in significant mineral changes along the fault that could affect local distribution coefficients. Changes in distribution coefficients could result from the growth of mineral fillings in the fault zone itself or from the sealing effect of the mineral fillings that prevent interaction between fluids moving through the fault zone and the surrounding country rock. Activity 8.3.1.8.4.1.2 will provide an assessment of this initiating event and satisfy parameter 2 by analyzing data from core and the mapping of drifts and shafts to review the evidence of significant changes during past faulting events to determine the age, type, and extent of mineral changes that have occurred. The probability and location of faulting events will be determined from mapping and trenching activities that will provide data on slip rates, recurrence intervals, and locations of Quaternary faults. The assessment will integrate these data.

The third initiating event considers the possibility that offset on a fault could significantly affect distribution coefficients by diverting flow to pathways with significantly different mineral properties or water chemistry as a result of the juxtaposition of different lithologic units. Activity 8.3.1.8.4.1.3 will provide an assessment of this initiating event and satisfy parameter 3 by conducting modeling studies to determine the amount of offset necessary to produce significant changes. The results of the modeling activity will be combined with the probability that such offsets could occur using data on slip rates and recurrence intervals of faults in and near the controlled area as part of the assessment. The activity will summarize the results of the assessment in a report.

The fourth initiating event considers the possibility that changes in water-table levels or ground-water movement as a result of tectonic processes could produce significant mineral alteration in the formerly unsaturated rocks. Activity 8.3.1.8.4.1.4 will provide an assessment of this initiating event and partially satisfy parameter 4 by calculating the probability of significant faulting events and the nature of water-table fluctuations that could be expected from such events. Activity 8.3.1.3.7.1.2 will complete the characterization of this parameter by calculating the rate that mineral changes could occur in this environment using data on the history of mineral and geochemical alteration at Yucca Mountain and incorporating the results in

INTERMEDIATE PERFORMANCE MEASURE

DATA ANALYSIS AND ASSESSMENT

KEY DATA GATHERING ACTIVITIES

8.3.1.8-94

CONSULTATION DRAFT

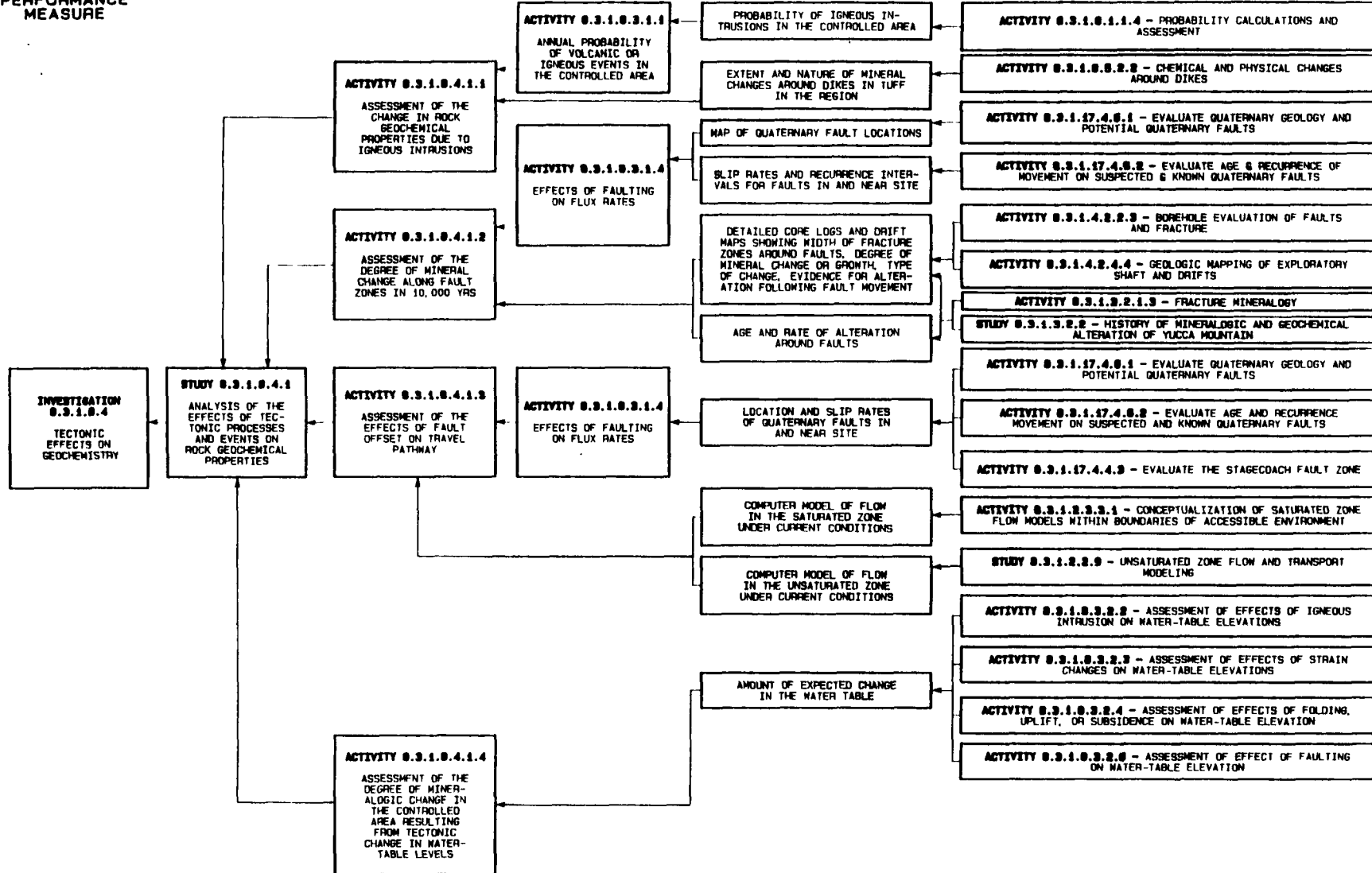

Figure 8.3.1.8-8. Logic diagram for Study 8.3.1.8.4.1 (analysis of the effects of tectonic processes on rock geochemical properties).

CONSULTATION DRAFT

the integrated geochemical transport calculations. These data will be combined with the results of Study 8.3.1.8.3.2 on the probability of significant water-level changes occurring as the result of tectonic processes to complete the assessment. The activity will summarize the results of the assessment in a report.

8.3.1.8.4.1 Study: Analysis of the effects of tectonic processes and events on rock geochemical properties

The activities in this study provide assessments of the initiating events related to local changes in distribution coefficients resulting from tectonic processes and events.

8.3.1.8.4.1.1 Activity: Assessment of the change in rock geochemical properties due to igneous intrusions

Objectives

The objective of this activity is to assess the probability that igneous intrusions will cause significant changes in local distribution coefficients in the controlled area in 10,000 yr.

Parameters

The parameters for this activity are the effects of igneous intrusions on local distribution coefficients.

Description

This activity will use the data collected by Activity 8.3.1.8.5.2.2 on the nature and extent of mineral changes occurring around dikes in tuffs to evaluate whether the observed changes would significantly alter distribution coefficients in the controlled area. The results of this evaluation will be combined with the probability of igneous intrusions occurring in the controlled area from Activity 8.3.1.8.3.1.1 to produce the assessment on the probability of significant change. The results of the assessment will be summarized in a report that will include the following topics:

1. A summary of the data and calculations used in the assessment.
2. The results of the assessment.
3. An analysis of the assumptions and uncertainties in the data and the assessment.

Methods and technical procedures

Activity 8.3.1.8.4.1.1 will only synthesize and compile data collected by other activities and will use the methods and technical procedures given in the following table.

CONSULTATION DRAFT

Method	Technical procedure		Date
	Number	Title	
Analysis of data	QP 3.1	Scientific investigation control and design control	20 Dec 86
Use of data from non-Project sources	NNWSI-SOP-03-03	Acceptance of data or data interpretation not developed under the NNWSI Project QA Plan	31 Jan 86

8.3.1.8.4.1.2 Activity: Assessment of the degree of mineral change along fault zones in 10,000 yr

Objectives

The objective of this activity is to assess the probability that local distribution coefficients will be significantly altered along faults in 10,000 yr by displacement events.

Parameters

The parameter for this activity is the degree of mineral change along a fault zone in 10,000 yr.

Description

This activity will review and summarize the data on the nature and extent of mineralization along faults for evidence of brecciation and re-ementation that would result from periodic fault offset. This data will come from drilling activities that recover core from fault zones and the activities that will conduct geologic mapping of the shafts and drifts of the exploratory shaft facility. Data on the age and mineralogy of these zones will also be used in an assessment of the nature, extent, and rate of possible changes in distribution coefficients. These results will be combined with the probability of faulting events occurring in the controlled area derived from the data on slip rates and recurrence intervals in Activity 8.3.1.8.3.2.3 to complete the assessment of the probability that significant changes will occur. The results of the assessment will be summarized in a report that will include the following topics:

1. A summary of the data and calculations used in the assessment.
2. The results of the assessment.
3. An analysis of the assumptions and uncertainties in the data and the assessment.

CONSULTATION DRAFT

Methods and technical procedures

Activity 8.3.1.8.4.1.2 will only synthesize and compile data collected by other activities and will use the methods and technical procedures given in the following table.

Method	Technical procedure		Date
	Number	Title	
Analysis of data	QP 3.1	Scientific investigation control and design control	20 Dec 86
Use of data from non-Project sources	NNWSI-SOP-03-03	Acceptance of data or data interpretation not developed under the NNWSI Project QA Plan	31 Jan 86

8.3.1.8.4.1.3 Activity: Assessment of the effects of fault offset on travel pathway

Objectives

The objective of this activity is to assess the possibility that offsets occurring on faults in 10,000 yr in the controlled area will divert radionuclides to travel pathways with significantly different distribution coefficients or water chemistry.

Parameters

The parameters for this activity are the effects of fault offset on travel pathway.

Description

This activity will use models based on the models of flow in the saturated and unsaturated zones under current conditions from Activity 8.3.1.2.3.3.1 and Study 8.3.1.2.2.5 to estimate the amount of offset necessary to produce significant changes in radionuclide travel pathways. To produce the assessment, these results will be combined with the probability of such displacements occurring in the controlled area derived from slip rate and recurrence interval data in Activity 8.3.1.8.3.1.4. The results of the assessment will be summarized in a report that will include the following topics:

1. A summary of the data and calculations used in the assessment.
2. A discussion of the modeling techniques and their results.

CONSULTATION DRAFT

3. The results of the assessment.
4. An analysis of the assumptions and uncertainties in the data and the assessment.

Methods and technical procedures

Activity 8.3.1.8.4.1.3 will only synthesize and compile data collected by other activities and will use the methods and technical procedures given in the following table.

Method	Technical procedure		
	Number	Title	Date
Analysis of data	QP 3.1	Scientific investigation control and design control	20 Dec 86
Use of data from non-Project sources	NNWSI-SOP-03-03	Acceptance of data or data interpretation not developed under the NNWSI Project QA Plan	31 Jan 86
Validation of computer models	NNWSI-SOP-03-02	Software quality assurance	28 Feb 86
	QP 3.2	Use and control of computer programs	20 Dec 86

8.3.1.8.4.1.4 Activity: Assessment of the degree of mineral change in the controlled area resulting from tectonically induced change in water-table elevations

Objectives

The objective of this activity is to assess the probability and nature of tectonically induced changes in water-table level that might result in significant mineral changes in the newly saturated or unsaturated rock.

Parameters

The parameter for this activity is the degree of mineral change in the controlled area resulting from changes in water-table level or flow paths caused by tectonic processes in 10,000 yr.

Description

This activity will generate an assessment of the probability that faulting events could significantly alter water levels during the postclosure

CONSULTATION DRAFT

period and estimate the amount of these water-table fluctuations. The data for this assessment will be provided by Study 8.3.1.8.3.2. The assessment will be used by Activity 8.3.1.3.7.1.2 to complete characterization of the parameter by calculating the degree of mineral change such fluctuation could produce and the effect of these changes on the geochemical/geophysical model of Yucca Mountain and integrated geochemical transport calculations. The results of the assessment will be summarized in a report that will include the following topics:

1. A summary of the data and calculations used in the assessment.
2. The results of the assessment.
3. An analysis of the assumptions and uncertainties in the data and the assessment.

Methods and technical procedures

Activity 8.3.1.8.4.1.4 will only synthesize and compile data collected by other activities and will use the methods and technical procedures given in the following table.

Method	Technical procedure		Date
	Number	Title	
Analysis of data	QP 3.1	Scientific investigation control and design control	20 Dec 86
Use of data from non-Project sources	NNWSI-SOP-03-03	Acceptance of data or data interpretation not developed under the NNWSI Project QA Plan	31 Jan 86

8.3.1.8.4.2 Application of results

The information derived from the study and activities described above will be used in the following issues and investigations.

<u>Issue or investigation</u>	<u>Subject</u>
1.1	Total system performance (Section 8.3.5.13)
1.8	NRC siting criteria (Section 8.3.5.17)
1.9	Higher level findings--postclosure (Section 8.3.5.18)
8.3.1.3.7	Radionuclide retardation investigation

CONSULTATION DRAFT

8.3.1.8.4.3 Schedule and milestones

This investigation addresses postclosure tectonic effects on geochemistry and contains one out-year study: 8.3.1.8.4.1 (analysis of the effects of tectonic processes and events on rock geochemical properties). In the figure that follows, the schedule information for this study is presented in the form of a timeline. The timeline extends from implementation of the approved study plan to the issuance of the final products associated with the study. Summary schedule and milestone information for this investigation can be found in Section 8.5.1.1.

The activities of this entire investigation are planned to progress in parallel with performance and design activities in an iterative fashion. The results of this study will be used toward the resolution of Issue 1.1 (total system performance) and to support advanced conceptual and license application designs.

Completion of Study 8.3.1.8.4 is constrained by the availability of the following data: the probability of igneous intrusions in the controlled area from Investigation 8.3.1.8.1; mineralogic changes around dikes and sills from Investigation 8.3.1.8.5; location, Quaternary slip rate, and recurrence interval on faults from Investigation 8.3.1.17.4; detailed core logs and exploratory drift maps showing degree and type of mineral change around faults and fractures from Investigation 8.3.1.4.2; age and rate of mineral alteration around fractures from Investigation 8.3.1.3.2; computer models of flow in the unsaturated zone from Investigation 8.3.1.2.2; computer model of flow in the saturated zone from Investigation 8.3.1.2.3; and the amount of expected change in water-table elevation due to tectonic processes and events from Investigation 8.3.1.8.3.

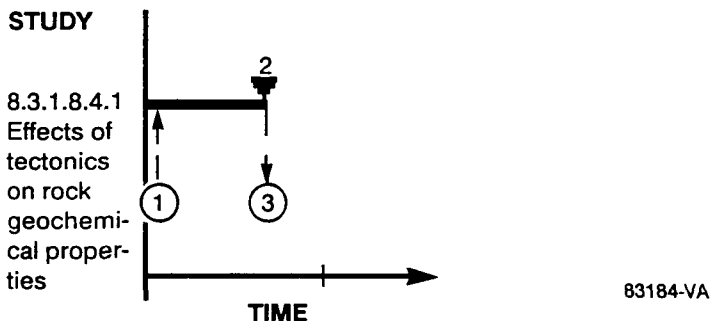

The study number and title corresponding to the timeline are shown on the left of the preceding figure. The points shown on the timeline represent major events or important milestones associated with the study. Solid lines represent study durations, and dashed lines show interfaces. The data input and output at the interfaces are shown by circles.

The points on the timeline and the data input and output at the interfaces are described in the following table:

CONSULTATION DRAFT

Point
number

Description

- 1 Data on input from Investigations 8.3.1.8.1 (volcanic activity), 8.3.1.8.5 (postclosure tectonics data collection and analysis), 8.3.1.17.4 (preclosure tectonics data collection and analysis), 8.3.1.4.2 (geologic framework), 8.3.1.3.2 (mineralogy, petrology, and rock chemistry), 8.3.1.2.2 (site unsaturated zone hydrologic system), 8.3.1.2.3 (site saturated zone hydrologic system), and 8.3.1.8.3 (tectonic effects on hydrology).
- 2 Milestones Q149, Z397, Z398, and Z399. A series of reports available for use by Issue 1.1 (total system performance) assessing the effects of igneous intrusions, faulting or tectonically induced changes in water-table elevation on rock geochemical properties along likely travel pathways.
- 3 Data input to Issue 1.1 from reports assessing the effects of igneous intrusions, faulting or tectonically induced changes in water table elevation on rock geochemical properties along likely travel pathways.

8.3.1.8.5 Investigation: Studies to provide the information required by the analysis and assessment investigations of the tectonics program

Technical basis for obtaining the information

Links to the technical data chapters and applicable support documents

The following sections of the SCP data chapters provide a technical summary of existing data relevant to this investigation:

<u>SCP section</u>	<u>Subject</u>
1.3.2.1	Volcanic history
1.3.2.2	Structural history
1.5.1	Volcanism

Parameters

The following parameters will be measured or calculated during the studies planned to satisfy this investigation:

1. Location, age, and volume of igneous deposits younger than 4 million yr and within 70 km of the site.
2. Detailed maps showing the relation of geologic structures to selected young volcanic centers.
3. Map showing depth to Curie isotherm.

CONSULTATION DRAFT

4. Chemical and physical changes around dikes in tuff.
5. Petrology and geochemistry of late Cenozoic volcanic rocks in the region.
6. Evaluation of folding in the region and its relation to faulting or detachments.
7. Evaluation of heat-flow data.

Purpose and objectives of the investigation

The studies and activities in this investigation will collect the field data called for by the analysis and assessment activities in Investigations 8.3.1.8.1 through 8.3.1.8.4. Because most of the data required by these analysis and assessment activities are being collected by other programs, the activities in this investigation are limited to a small number providing data to support the analysis of volcanic, igneous intrusion, and folding processes. Figures 8.3.1.8-3 through 8.3.1.8-8 and Tables 8.3.1.8-1 through 8.3.1.8-6 show the relationship of the data gathering activities in this section to the analysis and assessment investigations.

Technical rationale for the investigation

One of the main requirements in the evaluation of the hazard of volcanic or igneous events is the calculation of the probability that such events would actually occur in the repository or the controlled area. Parameter 1 indicates the data required by Activities 8.3.1.8.1.1.1 and 8.3.1.8.1.1.4 to carry out this calculation. Activities 8.3.1.8.5.1.1 through 8.3.1.8.5.1.4 are designed to improve the existing data base on the age, location, and volume of young volcanic and igneous rocks in the region surrounding the site. These activities refine the dating of known occurrences using a variety of techniques, many of which have not previously been employed, and determine by drilling the nature of suspected buried deposits.

Another concern related to the probability of volcanism in the site area is that the location of any intrusion may not be entirely random across the area but controlled by structural features. To address this possibility, parameter 2 has been identified as one of the data requirements of Activity 8.3.1.8.1.1.2. Activity 8.3.1.8.5.1.3 will satisfy the requirement by completing detailed geologic mapping around selected volcanic features to clarify the relationship that might exist between the volcanic features and local structures. Parameter 5 has also been identified as a data requirement of Activity 8.3.1.8.1.1.2; this parameter will be used to address tectonic models for the time-space patterns of igneous events in the Yucca Mountain area and the structural controls for volcanic sites or future volcanic sites at or adjacent to Yucca Mountain. These data will be factored into probability calculations. Activity 8.3.1.8.5.1.5 will evaluate petrologic and volume trends of volcanic fields through time to test for indications of waning volcanism or increases in the rate of eruptive activity associated with decreasing eruption volumes.

For data on thermal anomalies in the area that might be related to magma bodies that could be sources of volcanic or igneous activity, parameters 3

CONSULTATION DRAFT

and 7 have been identified as a data requirements of Activity 8.3.1.8.1.1.3. Activities 8.3.1.8.5.2.1 and 8.3.1.8.5.2.3 will satisfy the requirement by generating maps showing the depth to the Curie isotherm and heat-flow data in the area surrounding the site.

Parameter 4 has been identified as a data requirement of both Activities 8.3.1.8.3.3.1 and 8.3.1.8.4.1.1 and will provide information on the nature and extent of physical and geochemical changes around dikes and other intrusions. Activity 8.3.1.8.5.2.2 will satisfy this requirement by collecting the required data from field studies of known intrusions in the region around the site and from literature reviews.

Parameter 6 will provide general regional data on the relationship of Neogene folding in the region to faults and detachments. Activity 8.3.1.8.5.3.1 will satisfy this parameter by reviewing the available literature and possible detailed mapping in selected areas.

8.3.1.8.5.1 Study: Characterization of volcanic features

The activities under this study will provide refined data on the age, location, and volume of young volcanic rocks in the vicinity of the site. These data will be used to refine the calculations on the probability of igneous or volcanic events occurring in the controlled area and penetrating the repository. Much of the work for this study has been completed and is described in Chapter 1. The focus of this study is to summarize continuing activities that are necessary to complete risk assessment. The major activities include (1) geochronology studies to refine the ages of Quaternary basaltic activity and the youngest silicic volcanic activity in the Yucca Mountain area, (2) refining the area parameter used in probability calculations based on revised procedures to quantify the structural controls of surface volcanic centers, (3) drilling of prominent aeromagnetic anomalies in Crater Flat and the Amargosa Valley that are inferred to represent shallowly buried basaltic volcanic centers, and (4) collecting additional field data on the possibility of structural controls on volcanism in the vicinity of the site.

Other activities in this study will investigate the petrologic and geochemical cycles of volcanic fields in the region. The goals of these activities are to

1. Establish the geochemical sequence through time of the lava flows and scoria deposits at Crater Flat for correlation with basaltic ashes exposed in various trenches excavated in alluvium for the preclosure tectonic program (Study 8.3.1.17.6) and test petrologic models of polycyclic volcanism.
2. Examine and document the temporal and spatial geochemical patterns of the late Cenozoic basaltic fields of the southwest Basin and Range. These patterns will be compared in Activity 8.3.1.8.1.1.2 with patterns established from the Crater Flat data and to test tectonic models for the spatial distribution for volcanic activity at the Crater Flat volcanic field.

CONSULTATION DRAFT

These data will be used in Activity 8.3.1.8.1.2 to assess the significance of petrologic patterns of the Crater Flat volcanic field and to examine, in conjunction with geophysical data, the possibility that the Death Valley-Pancake Range volcanic zone (DV-PRVZ) represents an incipient rift zone.

8.3.1.8.5.1.1 Activity: Volcanism drillholes

Objectives

The objective of this activity is to investigate the origin of four aeromagnetic anomalies found in Crater Flat and the Amargosa Valley. These anomalies are inferred to represent shallowly buried basaltic or silicic volcanic centers or intrusive bodies. The anomaly sites will be drilled and continuous core recovered from the drillholes. Data from this work will be used to refine probability calculations, to evaluate the tectonic setting of volcanic centers, and to test concepts of the temporal geochemical patterns of basalts in the NTS region.

Parameters

The data gathered by other activities and needed for this activity are

1. The location and extent of aeromagnetic anomalies.
2. The potassium-argon (K-Ar) and Ar-40/Ar-39 age determinations of volcanic material recovered the drilling program. This information will be obtained from Activity 8.3.1.8.5.1.2.

The data to be gathered by this activity are

1. Core from drillholes.
2. Stratigraphy and location of core from drillholes.
3. Magnetic polarity measurements of core.
4. Major-element geochemical data of recovered volcanic materials.
5. Trace-element geochemical data of recovered volcanic materials.
6. Sr and Nd isotopic data of recovered volcanic materials.
7. Petrography of recovered volcanic materials.

Description

The inferred, buried volcanic centers may represent volcanic events that have not been documented in the geologic record. These anomalies need to be drilled, dated, and volumes obtained to apply to volcanic rate calculations used for the probability model for the Yucca Mountain area.

Four anomalies have currently been identified from aeromagnetic data for investigation using drillholes (USGS, 1978). One is located in southwest Crater Flat, the remaining three are in the Amargosa Valley (Figure 8.3.1.8-9). The anomaly sites will be drilled and core recovered from volcanic rocks encountered in the hole. Four drillholes are currently planned and each will be drilled to a depth of approximately 330 m.

CONSULTATION DRAFT

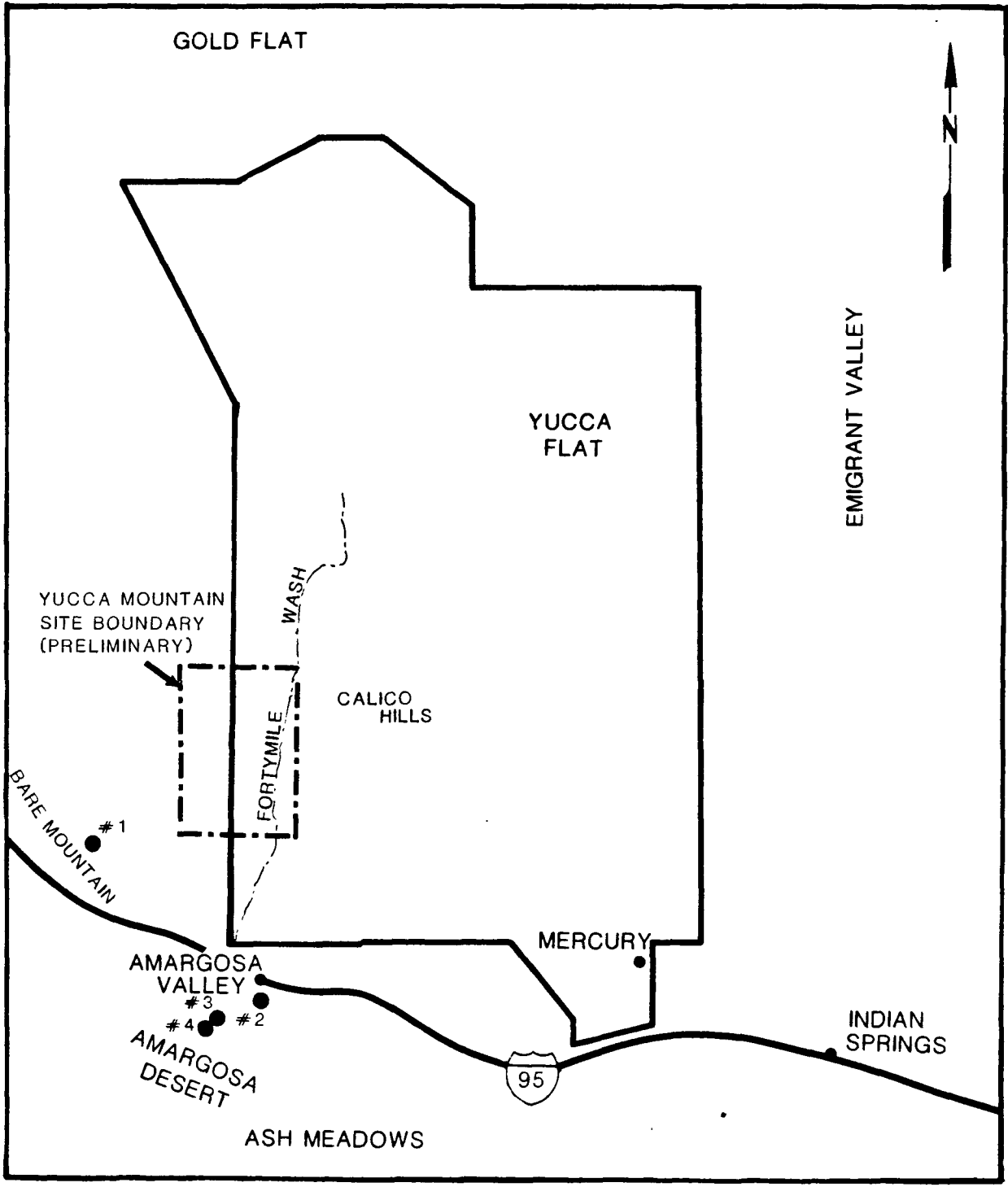

- NEVADA TEST SITE BOUNDARY
- #3 LOCATION AND DRILLHOLE NUMBER OF V-SERIES DRILLHOLES

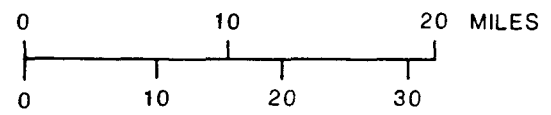

Figure 8.3.1.8-9. Map showing location of volcanism drillholes

CONSULTATION DRAFT

The anomalies may be buried surface volcanic centers or they could be intrusive bodies. If they are intrusive bodies, there are no established constraints on their age--they could be as young as the younger events in the Yucca Mountain region. The thickness of the recovered volcanic core material and the geometry of aeromagnetic anomalies will be used to estimate volumes of buried volcanic centers. This data will be combined with potassium-argon ages to refine probability calculations and establish a tectonic model of basaltic volcanic activity (Activity 8.3.1.8.1.1.4). K-Ar ages of the core will be combined with major- and trace-element data and isotopic data to test geochemical patterns of basaltic volcanism in the NTS region (Activities 8.3.1.8.5.1.4 and 8.3.1.8.5.1.5).

Methods and technical procedures

Drilling plans for the four holes will be completed in FY 1988 and drilling is scheduled to take place in FY 1989. Drilling plans for two holes (V-1 and V-2) have been completed. Procedures and the Quality Assurance program are detailed in the completed drilling plan. Major-element data will be obtained using x-ray fluorescence (XRF). Trace-element data will be obtained by instrumental neutron activation analysis (INAA) and XRF. Isotopic data for Sr and Nd are obtained by mass spectrometry.

Method	Technical procedure		
	Number	Title	Date
Magnetic polarity measurements	In preparation	TBD ^a	FY 1987
X-ray fluorescence procedures	In preparation	TBD	FY 1987
Isotopic measurements	In preparation	TBD	FY 1988
Microprobe operating procedure	TWS-ESS-DP-07, R2	TBD	Nov 82
Sample preparation: procedure	TWS-ESS-DP-04, R4	TBD	Jan 83
Sample preparation: rock powders	TWS-ESS-DP-10, R8	TBD	Nov 82
NTS core petrography procedure	TWS-ESS-DP-03	TBD	Nov 82
Volcanic hazard investigations work plan	TWS-INC-WP-12	TBD	Nov 82

CONSULTATION DRAFT

Method	Technical procedure		Date
	Number	Title	
Instrumental neutron activation analysis (INAA) procedures	In preparation	TBD	FY 1988

^aTBD = to be determined.

8.3.1.8.5.1.2 Activity: Geochronology studies

Objectives

The objective of this activity is to establish the chronology of basaltic volcanism and the youngest silicic volcanic activity in the Yucca Mountain region. These data will be used to revise the rate parameter of the volcanic probability calculations and to determine the age of cessation of silicic volcanic activity. The geochronology studies have been under way for a number of years and the chronology of older basaltic activity (> 8 million yr) has been established. Further studies are required for three topics:

1. The age of Quaternary volcanic events in the Yucca Mountain region.
2. The age of the youngest volcanic event in the Yucca Mountain area.
3. The age of the youngest silicic volcanic activity in the region with emphasis on the Black Mountain caldera or young silicic rocks that may be encountered in shallow volcanic drillholes.

Parameters

The data gathered by other activities and needed for this activity are

1. Geographic location and geologic field relations of volcanic rocks or volcanic features used for age determinations. This information will be obtained from Activity 8.3.1.8.5.1.3.
2. Core from volcanic rocks recovered from the volcanism drillholes. This material will be obtained from Activity 8.3.1.8.5.1.1.

The data to be gathered by this activity are

1. Age determinations of volcanic rocks using the potassium argon (K-Ar) and Ar-40/Ar-39 methods.
2. Age determinations of silicic volcanic rocks using a single crystal, laser-fusion method for determination of the Ar-40/Ar-39 ages.

CONSULTATION DRAFT

3. U-Th disequilibrium measurements of crystals and whole rock for age calibration of basaltic volcanic rocks.
4. Measurement of the cosmogenic He-3 accumulation in basaltic volcanic rocks to obtain the surface exposure age of the rocks.
5. Measurement of the cosmogenic Cl-36 accumulation in basaltic volcanic rocks to obtain the surface exposure age of the rocks.
6. Measurement of cation element ratios in desert varnish developed on basaltic volcanic rocks to calibrate the time of surface exposure of the rocks.
7. Carbon-14 dating of desert varnish developed on basaltic volcanic rocks to determine the surface exposure age of the rocks or volcanic features.
8. Measurement of the paleomagnetic pole position of young basaltic volcanic rocks to test age constraints from crystallization and surface exposure age determinations.
9. Measurement of scoria cone and lava flow geomorphic parameters to evaluate the surface exposure age of the volcanic features.
10. Measurement of soil development for evaluation of the age of soils developed on young basaltic rocks or volcanic features.

Description

Potassium-argon (K-AR) age determinations are needed to establish the chronology of volcanic activity in the Yucca Mountain region. Previous work has established the timing of major episodes of activity in the region (Crowe et al., 1986). The focus of work for probability calculations has been based on patterns of basaltic activity during the last 4.0 million yr (Crowe et al., 1982). The age of basaltic volcanic events during this interval is a key parameter for the probability calculations. It is important, therefore, to obtain high quality age determinations for volcanic events in this age interval. Duplicate ages are needed for the volcanic centers to

- (1) establish the accuracy and precision of the age determinations and
- (2) allow statistical analysis of age data.

A second problem is the age of the youngest silicic volcanic center in the Yucca Mountain region, the Black Mountain caldera. Published ages of the Thirsty Canyon Tuff, the major outflow unit of the Black Mountain caldera, are as young as 6.5 million yr (Kistler, 1968). These age determinations were obtained from anorthoclase mineral separates. This mineral tends to lose Ar and therefore the ages are probably minimum ages and do not record the crystallization age of the mineral. Dated basalt flows that overlie individual units of the Thirsty Canyon Tuff range in age from 8.0 to 9.1 million yr and are inconsistent with the anorthoclase ages. This inconsistency needs to be resolved through additional K-Ar dating of the overlying basalt flows and determination of single-crystal Ar-40/Ar-39 ages of minerals in the Thirsty Canyon Tuff.

CONSULTATION DRAFT

The final problem that requires refinement of continuing work is an evaluation of the age or ages of the Lathrop Wells volcanic center. This center was considered to be about 200,000 to 300,000 yr old as reported in the environmental assessment for Yucca Mountain (DOE, 1986b). However, new data suggest the lava flows are somewhat younger and the scoria cone is much younger than this reported age. A sufficient number of K-Ar dates will be obtained to resolve the age of the lavas through statistical analysis and to address the problem of why there has been such variability in the results of K-Ar age determinations. Dating of the scoria cone is much more difficult. To resolve this problem, a variety of techniques will be used that either provide crystallization ages of the magma that formed the cone or date the time of surface exposure of the cone. Because these techniques are developmental, multiple results will be obtained from two separate laboratories, and the results will be compared for consistency. Additionally, the measurements of paleomagnetic pole positions, the evaluation of geomorphic parameters of the cone, and the soils chronology provide cross-checking procedures for the data obtained from crystallization ages and surface exposure ages.

Methods and technical procedures

The methods and technical procedures for K-Ar measurements will follow the conventional techniques established by the University of California at Berkeley and the USGS geochronology laboratories. The USGS work is described in NWM-USGS-GCP-06, R0, Potassium-Argon Dating, effective date June 15, 1981, controlled date October 21, 1986. The procedures of U.C. Berkeley will be evaluated and necessary documentation will be provided to qualify or upgrade the procedures for the NNWSI Project Quality Assurance program.

The following work requires technique development to establish the procedures for the measurements and to evaluate whether this work will provide data that will be used in site characterization:

1. Measurement of single crystal Ar-40/Ar-39 ages in volcanic rocks using laser excitation.
2. Measurement of U-Th disequilibrium in volcanic crystals and whole rock samples.
3. Measurement of cosmogenic He-3 accumulation in basaltic volcanic rocks.
4. Measurement of cosmogenic Cl-36 accumulation in basaltic volcanic rocks.
5. Measurement of C-14 ages of desert varnish developed on basaltic volcanic rocks. This work will be covered by TWS-MSTQA-QP-14, R1, Research and Development (Experimental) Procedure, effective date May 19, 1986.

When these techniques are established and the data are judged to be of use to site characterization for the volcanic hazard studies, detailed procedures will be developed for each task.

CONSULTATION DRAFT

Detailed procedures are being prepared for the cation ratio work with desert varnish. The first procedure, TWS-ESS-DP-114, Sample Collection for Rock Varnish Studies, has been completed, with an effective date of issue of April, 1987.

The detailed procedures for the measurement of paleomagnetic pole positions are in preparation.

Procedures for studies related to the calibration of geomorphic parameters for basaltic volcanic centers and the measurement of soil parameters on basaltic volcanic flows and volcanic features are in preparation.

8.3.1.8.5.1.3 Activity: Field geologic studies

Objectives

The objective of this activity is to establish the field geologic relations and the eruptive history of basaltic volcanic centers in the Yucca Mountain region. Most of the work is completed, including reconnaissance mapping of older volcanic centers (>6 million yr) and detailed mapping of younger volcanic centers. Two problems remain:

1. Recently acquired geochronology data have shown that some small volume basalt centers may be polycyclic (i.e., formed during multiple cycles of volcanic activity separated by significant intervals of inactivity). Further geologic mapping coupled with geochronology studies are required to investigate how common polycyclic activity is at the young (<4.0 million yr) volcanic centers of the Yucca Mountain region.
2. Field studies are needed to attempt to correlate scoria sequences exposed in alluvial deposits in trenches with the scoria cone deposits in the Crater Flat area.

Parameters

The data gathered by other activities and needed for this activity are

1. The results of geochronology studies from Activity 8.3.1.8.5.1.2.
2. The results of scoria geochemistry studies from Activity 8.3.1.8.5.1.4.

The data to be gathered by this activity are

1. Contact relations and geologic maps of basaltic volcanic centers in the Yucca Mountain region.
2. Eruptive sequences of basaltic volcanic centers in the Yucca Mountain region.

CONSULTATION DRAFT

3. Volumes of eruptive deposits of the basaltic centers in the Yucca Mountain region.
4. Tephra sequences and correlations among the scoria deposits of the basaltic volcanic centers of the Yucca Mountain region.

Description

A major assumption over the past several decades in geology is that small volume volcanic centers form during short periods of time (days, months, or at most years). Rock units such as separate lava flows or scoria cone clusters at basaltic volcanic centers are inferred to have formed virtually instantaneously relative to the resolving ability of conventional dating techniques. Recent geologic work using new techniques for dating the time of surface exposure of volcanic features combined with geomorphic analysis of degradation rates of volcanic features, and calibration of the time required for development of soils on young volcanic rocks has shown that some basaltic volcanic centers may be polycyclic. This means that they were formed from multiple pulses of basaltic activity with significant time intervals between events. The time interval between pulses may be sufficiently long to affect the rate parameter of probability calculations. Studies at the Lathrop Wells volcanic center suggest that it was formed by two, possibly three, pulses of basaltic magma over a period of time that may have exceeded 100,000 yr. Further geologic mapping coupled with geochronology studies are needed to evaluate the possibility of multiple eruption cycles at the Quaternary volcanic centers of the Yucca Mountain region. This work will allow refinement of constructed curves of magma volume versus time, which yields the rate of generation of magma, a key parameter for probability calculations. The second problem, correlation of tephra sequences, requires the same information base. Petrologic studies conducted to date assume the composition of lava represents the composition of the entire range of eruptions at small volume basalt centers. If these centers are polycyclic, the magma that formed separate pulses may differ in composition. Geologic mapping is required to identify the separate eruptive units, and these units will be evaluated as potential eruptive sources for tephra deposits that are interbedded with alluvium in the Yucca Mountain region.

Methods and technical procedures

This procedure has been in effect since November 24, 1982. Separate procedures will be written to cover significant parts of the Work Plan listed in the following table. A field studies procedure will be written in FY 1987.

Method	Technical procedure		
	Number	Title	Date
Geologic mapping of Quaternary volcanic centers	TWS-INC-WP-12, R0	Volcanic hazard investigations work plan	24 Nov 82

CONSULTATION DRAFT

Method	Technical procedure		Date
	Number	Title	
(field studies)	TBD ^a	TBD	FY 1987

^aTBD = to be determined.

8.3.1.8.5.1.4 Activity: Geochemistry of scoria sequences

Objectives

The objective of this activity is to determine the geochemistry of scoria sequences of different ages at the Lathrop Wells center and older centers in the Crater Flat area. These data will be used to test and develop petrologic models of polycyclic volcanism. The models will be used to test geologic assumptions made for (1) the probability calculations and (2) the time-space tectonic model for the distribution of basaltic volcanism developed from Activity 8.3.1.8.1.1.2. In addition, the data on the geochemistry of the scoria sequences will also be used to correlate basaltic ash interbedded in trenches with their correct eruptive source.

Parameters

The data gathered by other activities and needed for this activity are

1. Field relationships of scoria sequences at the Lathrop Wells volcanic center. This information will be obtained from Activity 8.3.1.8.5.1.3.
2. Ages of multiple scoria sequences at the Lathrop Wells center. This information will be obtained from Activity 8.3.1.8.5.1.2.

The data to be gathered by this activity are

1. Major-element data of scoria from Lathrop Wells center, and centers of the 1.1 to 1.5 million-year-old event in Crater Flat, and the 0.3 million-year sleeping Butte basalt centers.
2. Trace-element data of scoria from Lathrop Wells center, centers of the 1.1 to 1.5 million-year-old event in Crater Flat, and the 0.3 million-year Sleeping Butte basalt centers.
3. Mineral chemistry and petrography of scoria from Lathrop Wells center, centers of the 1.1 to 1.5 million-year-old event in Crater Flat, and the 0.3 million-year Sleeping Butte basalt centers.
4. Major- and trace-element chemistry of lava flows at the Lathrop Wells center the 1.1 to 1.5 million-year cycle in Crater Flat and the 0.3

CONSULTATION DRAFT

million-year Sleeping Butte basalt center. Most of this information has already been obtained (Crowe et al., 1986).

Description

At least two eruptive events, separated by a significant time interval, occurred at the Lathrop Wells center. This indicates that small basaltic centers of this type may be polycyclic. The major-, trace-element, and mineral chemistry of scoria sequences, bombs, and lava flows will be determined and combined with chronologic information (Activity 8.3.1.8.5.1.2) to test petrologic models of polycyclic volcanism. An understanding of the mechanisms of polycyclic volcanism derived from this modeling will provide an important means of assessing the possibility of future eruptions at the Lathrop Wells center. The geochemistry of scoria sequences will be used to correlate eruptive events to basaltic ash deposits exposed in trenches dug for tectonic studies (Study 8.3.1.17.4.6). In addition, the geochemistry of scoria can be used to constrain the existence of discrete eruptive events where field relationships may be ambiguous.

Methods and technical procedures

Preliminary work will be required to determine if scoria geochemistry corresponds to magma geochemistry, or if scoria geochemistry is modified during or after eruption. This will be done by comparing the major, trace element, and mineral data of basalt flows and bombs with data for scoria sequences of the same eruptive episode. Developmental work will be done to determine the best method of preparing scoria for analysis to minimize the effects of post-eruption alteration or addition of foreign material. Major-element data will be obtained using x-ray fluorescence (XRF). Trace-element data will be obtained by instrumental neutron activation analysis (INAA) and XRF. Mineral chemistry will be obtained by electron microprobe analysis.

8.3.1.8.5.1.5 Activity: Geochemical cycles of basaltic volcanic fields

Objectives

The objective of this activity is to determine the time-space geochemical variations of the volcanic fields of the southern Great Basin. These patterns will be compared with the documented geochemical patterns for the volcanic fields of the Yucca Mountain area. This information will be used to test a model that associates changes in basalt composition, increases in the eruptive frequency of polycyclic eruptions, and decreases in the volume of eruptive activity with the waning or termination stages of basaltic volcanic fields. This model, if valid, supports the idea that the Yucca Mountain area has passed the peak of maximum basaltic volcanic activity. Probability calculations, which are based on the peak rate of activity, could therefore be shown to be a worst-case approach to volcanic risk assessment.

Parameters

The data gathered by other activities and needed for this activity are geologic, geochemical, and geochronologic data (geologic maps, geochemical

CONSULTATION DRAFT

data, and K-Ar ages) for volcanic fields of the southern Great Basin. This information will be obtained from the published literature and from Activities 8.3.1.8.5.1.2, 8.3.1.8.5.1.3, and 8.3.1.8.5.1.4.

The data to be gathered by this activity are geochemical patterns of basaltic volcanism through time for volcanic fields of the southern Great Basin.

Description

Geochemical and geochronological studies of basalt of the Yucca Mountain area have shown that there are distinct variations in these parameters with time. Early eruptions were moderately high volume ($> 0.5 \text{ km}^3$) hypersthene hawaiite (3.7 to 1.1 million years). Subsequent eruptions were smaller volume (0.1 km^3) and the rocks are increasingly undersaturated (Vaniman et al., 1982; Crowe et al., 1986). Similar trends have been noted at the Lunar Crater and southern Death Valley volcanic fields (Crowe et al., 1986). These geochemical patterns may be indicative of the terminal stage of basaltic volcanic activity at a volcanic field. If this interpretation is valid, it supports the concepts being developed for the volcanic/tectonic model for the Crater Flat area including: (1) southwesterly migration of basaltic volcanic activity in the Yucca Mountain region, and (2) the observed decreased volume of basaltic activity in the Yucca Mountain area. Both concepts support the assumption that the calculated probability bounds for future volcanic activity at Yucca Mountain are worst-case values. If volcanism is waning for this area, rates of magma generation calculated for past volcanic activity should be higher than future rates.

These concepts need to be tested by examining the time-space geochemical trends of other basaltic fields of the southern Great Basin. Emphasis would be placed on examining the geochemical patterns of older fields where there is clear evidence that volcanic activity has ended (no basaltic volcanic activity in Quaternary time). The patterns observed for the Yucca Mountain area need to be corroborated at several volcanic fields to support the volcanic/tectonic model. A second important parameter is the apparent increased frequency of volcanic eruptions associated with the transition to small volume, under-saturated basalt. This parameter needs to be investigated to determine if the trend could result in small-scale fluctuations in rates of volcanic activity. The fluctuations could be significant in forecasting future volcanic activity.

Methods and technical procedures

Major-element data will be obtained using x-ray fluorescence (XRF). Trace-element data will be obtained by instrumental neutron activation analysis (INAA) and XRF. Mineral chemistry will be obtained by electron microprobe analysis.

The methods and technical procedures for K-Ar measurements will follow the conventional techniques established by the University of California, Berkeley, and USGS geochronology laboratories. These procedures will be evaluated for conformance to the NNWSI Project Quality Assurance Program.

CONSULTATION DRAFT

Method	Technical procedure		Date
	Number	Title	
X-ray fluorescence (XRF) procedures	In preparation	TBD ^a	FY 1987
Microprobe operating procedure	TWS-ESS-DP-07	TBD	Nov 1982
Sample preparation: lab procedure	TWS-ESS-DP-04	TBD	Jan 1983
Sample preparation: rock powders	TWS-ESS-DP-10	TBD	Nov 1982
Volcanic hazard investigations work plan	TWS-INC-WP-12	TBD	Nov 1982
Instrumental neutron activation analysis (INAA) procedures	In preparation	TBD	FY 1988
Isotopic measurements	In preparation	TBD	FY 1988

^aTBD = to be determined.

8.3.1.8.5.2 Study: Characterization of igneous intrusive features

The activities in this study will gather data concerning the presence of thermal anomalies in the area and data on the geochemical and physical effects of intrusions on the surrounding rock. The evidence for the presence or absence of thermal anomalies will be used as part of the evaluation of the presence of significant magma bodies in the area and their relation to the probability of future volcanic events. The data on the effects of intrusions on surrounding rocks will be used as part of the assessments of the probability of significant changes on local fracture permeabilities and local effective porosities (Study 8.3.1.8.3.3) and local distribution coefficients (Study 8.3.1.8.4.1).

CONSULTATION DRAFT

8.3.1.8.5.2.1 Activity: Evaluation of depth of curie temperature isotherm

Objectives

The objective of this activity is to determine the depth of the curie temperature isotherm by analyses of existing magnetic survey data.

Parameters

The long wavelength attributes of magnetic survey data are the parameters for this activity.

Description

The curie temperature isotherm is the deepest level that significant crustal magnetic sources can exist; anomalies from these sources consequently have long wavelengths and very low amplitudes compared with shallower crustal sources. Hence, any method used to study the limiting depth of these sources must be capable of characterizing the long wavelength attributes of a magnetic survey. The Connard-Couch technique (Connard et al., 1983), accomplishes this characterization by dividing the survey area into overlapping rectangular cells, calculating the power spectrum of each cell, and analyzing the shape of the long wavelength part of each spectrum. All of the sources contributing to the spectrum are treated as a statistical set, or ensemble.

This method and its application to a part of the Oregon Cascade Range was described by Connard et al. (1983). Their curie temperature depths agreed approximately with published heat flow measurements, recent structural features, and surface geothermal manifestations. Couch et al. (1986) have summarized their results in the Cascade Range. They now have analyzed magnetic data over the Cascade geologic province from Mount Hood to Lassen Peak, and the agreement between their curie temperature depths and heat flow measurements is quite remarkable.

The proposed method has some limitations. Anomalies due to deep sources are difficult to separate from their dominant shallow counterparts, no matter which method is used, and particularly in Nevada, where the data are of lesser quality and the geologic situation more complex than in the Oregon Cascade Range. Finally, the method estimates the depth to the bottom of magnetic sources, which are assumed to correspond to curie temperatures.

Nevertheless, this technique offers a method for characterizing undulations of the curie temperature isotherm in Nevada, and to compare areas of shallow isotherms with areas of recent volcanism and zones of high heat flow.

Methods and technical procedures

The methods and technical procedures for Activity 8.3.1.8.5.2.1 are given in the following table.

CONSULTATION DRAFT

Method	Technical procedure		Date
	Number	Title	
	(NWM-USGS-)		
Curie temperature isotherm analysis	Needed	Connard-Couch technique of magnetic data analysis	TBD ^a

^aTBD = to be determined.

8.3.1.8.5.2.2 Activity: Chemical and physical changes around dikes

Objectives

The objective of this activity is to gather data on the nature and extent of chemical and physical changes that may occur in the surrounding tuffs as a result of the intrusion of dikes or sills.

Parameters

The parameters for this activity are

1. The extent and nature of changes to physical properties such as fracturing and effective porosity that could affect ground-water flow in tuffs surrounding a basaltic dike or sill.
2. The extent and nature of changes to geochemical properties that could affect local distribution coefficients (K_d s) in tuffs surrounding a basaltic dike or sill.

Description

As discussed in Sections 1.3.2 and 1.5.1, basaltic volcanism is considered the only credible igneous process that could affect the site. This activity will investigate the possibility that the intrusions related to this type of activity such as dikes or sills could adversely affect the hydrologic or geochemical characteristics of the surrounding rock in a significant manner. The first phase of the activity will be a literature review of the effects of dikes and sills of the type expected in the area on tuffs and other rock types. This will be followed, as necessary, by a field investigation of selected localities in the region where dikes or sills are known to have penetrated rock types similar to those found at the site. The rocks surrounding these intrusions will be examined petrologically to describe the nature of the mineral changes caused by the intrusion and the distance that these changes extend from the intrusion. Changes in fracturing and other physical characteristics that could affect ground-water flow will also be described. These data will be used by Activities 8.3.1.8.3.3.1 and

CONSULTATION DRAFT

8.3.1.8.4.1.1 as part of the assessment of the effects of igneous intrusions on hydrologic and geochemical characteristics of the site.

Methods and technical procedures

The methods and technical procedures for Activity 8.3.1.8.5.2.2 are given in the following table.

Method	Technical procedure		Date
	Number	Title	
	(NWM-USGS-)		
Petrologic examination of samples	GP-03, R0	Stratigraphic studies	1 Mar 83
	GCP-01, R0	Radiometric-age data bank	15 June 81
	GCP-02, R1	Labeling, identification, and control of samples for geochemistry and isotope geology	20 Jan 87
Description of fracturing and physical properties	GP-01, R0	Geologic mapping	1 Mar 83
	GP-03, R0	Stratigraphic investigations	1 Mar 83
	GP-04, R0	Structural studies	1 Mar 83
	GP-07, R0	Geologic trenching studies	14 Aug 84
	GP-17, R0	Describing and sampling soils in the field	19 Feb 86
	GCP-01, R0	Radiometric-age data bank	15 June 81
	GCP-02, R1	Labeling, identification, and control of samples for geochemistry and isotope geology	1 Jan 87

CONSULTATION DRAFT

Method	Technical procedure		Date
	Number	Title	
	GCP-03, RO	Uranium-series dating	15 June 81
	GCP-04, RO	Uranium-trend dating	15 June 81

8.3.1.8.5.2.3 Activity: Heat flow at Yucca Mountain and evaluation of regional ambient heat flow and local heat flow anomalies

This activity will be undertaken in cooperation with Activity 8.3.1.9.2.1.3 (assessment of geothermal resources). Both activities are aimed at characterizing the local geothermal regime as it might relate to repository performance during the postclosure period. Activity 8.3.1.9.2.1.3 will focus on assessing geothermal activity as a potential resource. This activity (8.3.1.8.5.2.3) will evaluate the local ambient heat flow and local heat flow anomalies in relation to Quaternary volcanism. Data compilation and evaluation will be carried out jointly through both activities.

Objectives

The objectives of this activity are to

1. Compile available heat flow data at and near Yucca Mountain and identify local heat flow anomalies in conjunction with activity 8.3.1.9.2.1.3. The quality of these data will be assessed under this activity in conjunction with Activity 8.3.1.9.2.1.3.
2. Compile available calcite and silicate geothermometry data from calcite and silica deposits in soils and core and along faults in the vicinity of Yucca Mountain. These data will be assessed with respect to their utility for measuring thermal and hydrothermal perturbation associated with Quaternary volcanism, such as that at the Lathrop Wells volcanic center. In addition, the utility of such data for calibrating and evaluating theoretical calculations of the thermal and hydrothermal effects of volcanism will be assessed.
3. Assess the potential value of additional heat flow and other geothermometry studies for satisfying project goals. Recommendations will be made as to the objectives, nature and scope of any additional studies that may be needed, including the collection of geothermal data from existing or planned drill holes or specific methods of drill hole construction necessary to collect the highest quality heat flow data.

CONSULTATION DRAFT

Parameters

The parameters for this activity are

1. Geothermal profiles of drillholes.
2. Temperature of ground water from springs and wells.
3. Thermal conductivity of core and other samples.
4. Surface temperature.
5. Silica geothermometry of water samples.
6. Calcite geothermometry of calcite-silica deposits.

Description

Local heat flow anomalies could be associated with faults, shallow magma bodies, and (or) local areas of anomalous ground-water flow, such as segments of thermally driven ground-water convection cells. Internally consistent heat-flow calculations from drillhole UE-25a#3 in the Calico Hills yield values of as much as 3.08 to 3.34 HFU. These data are between two and three times the expected ambient values according to Sass et al. (1980), who suggest that Calico Hills is the focus of an ascending segment of a geothermal convection cell. The ambient thermal regime beneath Yucca Mountain is not known with sufficient confidence that a similar geothermal process can be ruled out there. In this activity, heat-flow calculations will be made for existing and planned drillholes where feasible. The data will be compiled onto maps and compared with other geological, hydrological, and geophysical data. Recommendations for additional heat-flow measurements will be made to evaluate local heat-flow anomalies. Such recommendations could include plans for an additional drillhole specifically constructed to acquire high quality data to evaluate regional ambient heat flow. Additional heat-flow data could also be required to evaluate tectonic or fault models, tectonic history, geothermal resource potential, regional ground-water flow, and/or calculation of ambient heat flow at and near Yucca Mountain. The silica geothermometry method used by Fournier et al. (1979) will be evaluated as to its utility in corroborative heat-flow calculations for Yucca Mountain in conjunction with Activity 8.3.1.9.2.1.3.

An understanding of the present thermal regime also is helpful to evaluate the magnitude and areal extent of the thermal perturbation due to Quaternary igneous activity. Available calcite and silica geothermometry data from calcite and silica deposits along faults and in soils and cores in the vicinity of Yucca Mountain (collected for Activity 8.3.1.5.2.1.5) will be compiled and assessed as to their utility for measuring thermal and hydrothermal perturbation associated with volcanism such as that at the Lathrop Wells Volcanic center (part of which may have synchronous with a pluvial maximum). Such data will also be evaluated as a method to confirm calculations of the thermal effects. Plans for additional studies will be made depending on the findings of this activity and program needs.

Methods and technical procedures

The methods and technical procedures for Activity 8.3.1.8.5.3 are given in the following table.

CONSULTATION DRAFT

Method	Technical procedure		Date
	Number	Title	
Heat flow studies	GPP-02,R0		11 Jan 82
	GPP-05,R1		7 Jan 86
Calcite and silica geothermometry	TBD ^a	Separation of oxygen and carbon from carbonate	
	TBD	Separation of oxygen from silicate	
Calcite and silica geothermometry (continued)	TBD	Separation of hydrogen from silicate	
	TBD	Liberation and collection of fluid inclusions	
	TBD	Mass-spectrometry for carbon	
	TBD	Mass-spectrometry for oxygen	
	TBD	Alpha-spectrometry	

^aTBD = to be determined.

8.3.1.8.5.3 Study: Investigation of folds in Miocene and younger rocks of region

The objective of this study is to establish the regional pattern and rate of Neogene folding. The parameters to be determined are distribution, amplitude, and age of folds.

8.3.1.8.5.3.1 Activity: Evaluation of folds in Neogene rocks of the region

Objectives

The objective of this activity is to establish the pattern, rate, amplitude, and wavelength of post-middle-Miocene folding in the region.

CONSULTATION DRAFT

Parameters

The parameters for this activity are the distribution, amplitude, and age of folds.

Description

Neogene strain within the NTS and vicinity consists of displacements due both to folding and to faulting. To explain the strain in terms of some tectonic model or theory, the contribution from folding as well as faulting must be considered. Preliminary evaluation indicates that where detachment faults are present, the wavelength of folds in upper-plate rocks is substantially less than that in lower-plate rocks. No attempt has as yet been made to rationalize fold patterns or relate them to wrench tectonics, but it is possible that the fold pattern in the area of intersection of the left-lateral fault systems (Mine Mountain and Rock Valley faults) with the right-lateral faults of the Las Vegas Valley shear zone may help show whether these faults are contemporaneous conjugate systems or independent systems of different age.

As a first step, data pertaining to folds from existing detailed geologic maps of the NTS will be abstracted and synthesized. Depending on the results of this effort, it may be necessary to supplement the data base through detailed mapping of folds in selected areas.

Evaluation of the structural attitude of Neogene rocks of the NTS and vicinity will involve synthesis of data pertaining to the structural attitude of the Horse Spring, Pavits Spring, and the younger volcanic, pyroclastic, and volcanoclastic rocks from existing detailed geologic maps.

Methods and technical procedures

The method and technical procedure for Activity 8.3.1.8.5.3.1 are given in the following table.

Method	Technical procedure		
	Number	Title	Date
	(NWM-USGS-)		
Evaluation of structural attitude of Neogene rocks (NTS and vicinity)	GP-01, RO	Geologic mapping	1 Mar 83

8.3.1.8.5.4 Application of results

The information derived from the studies and activities described previously will be used in the following programs and investigations:

CONSULTATION DRAFT

<u>Investigation</u>	<u>Subject</u>
8.3.1.8.1	Studies to provide information required on direct releases resulting from volcanic activity.
8.3.1.8.2	Studies to provide information required on rupture of waste packages due to tectonic events.
8.3.1.8.3	Studies to provide information required on changes in unsaturated and saturated zone hydrology due to tectonic events.
8.3.1.8.4	Studies to provide information required on changes in rock geochemical properties resulting from tectonic processes.
8.3.1.17.1	Volcanic activity that could affect repository design or performance.

8.3.1.8.5.5 Schedule and milestones

This investigation, which collects and analyzes postclosure tectonics data, contains three studies: 8.3.1.8.5.1 (characterization of volcanic features), 8.3.1.8.5.2 (characterization of igneous intrusive features), and 8.3.1.8.5.3 (investigation of folds in Miocene and younger rocks of the region). The first of these studies is ongoing while 8.3.1.8.5.2 and 8.3.1.8.5.3 are out-year studies.

In the figure that follows, the schedule information for these studies is presented in the form of timelines. The timelines extend from implementation of the approved study plans to the issuance of the final products associated with the studies. Summary schedule and milestone information for this investigation can be found in Section 8.5.1.1.

The activities of this entire investigation are planned to provide some of the data necessary to complete the analyses in Investigations 8.3.1.8.1, 8.3.1.8.2, 8.3.1.8.3, 8.3.1.8.4 and investigations in other programs.

The studies in this investigation are not seriously constrained by other program elements.

The study numbers and titles corresponding to the timelines are shown on the left of the following figure. The points shown on the timelines represent major events or important milestones associated with the study. Solid lines represent study durations, and dashed lines show interfaces. The data input and output at the interfaces are shown by circles.

CONSULTATION DRAFT

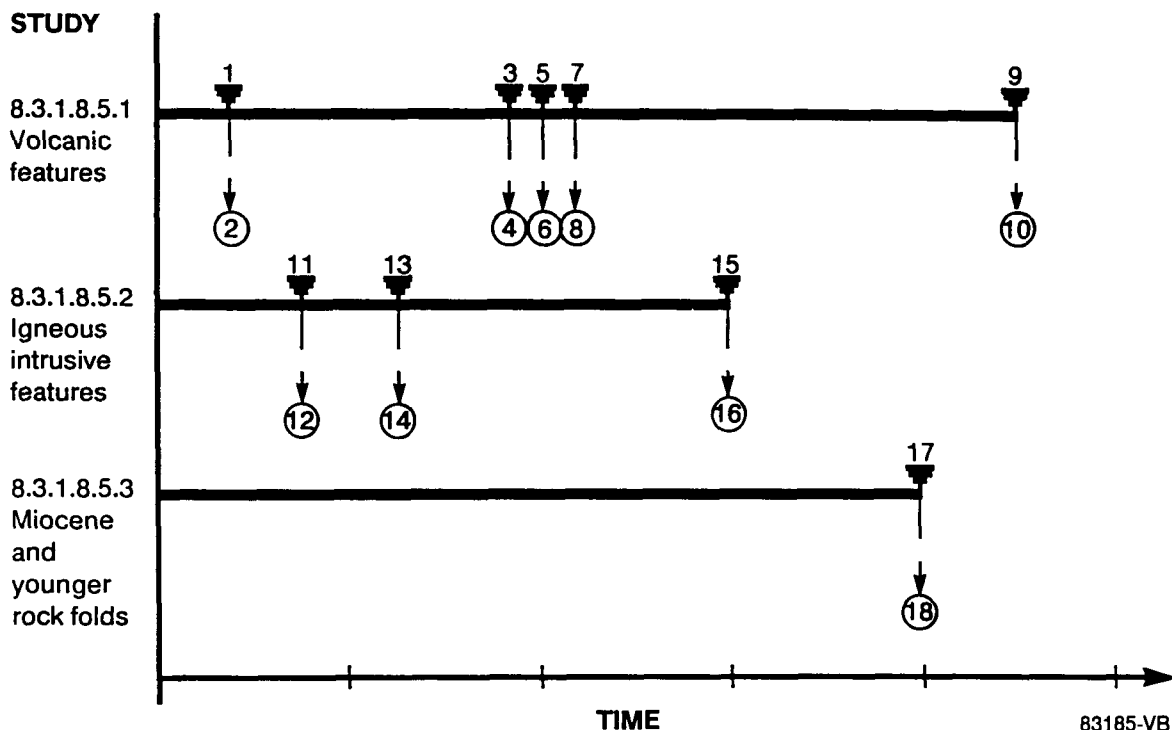

The points on the timeline and the data input and output at the interfaces are described in the following table:

<u>Point number</u>	<u>Description</u>
1	Milestone Z405. Field mapping of Lathrop Wells volcanic center completed.
2	Results from mapping of Lathrop Wells volcanic center to Studies 8.3.1.8.1.1 and 8.3.1.2.1.2.
3	Milestone Z407. Report available on geochemistry of Lathrop Wells scoria sequences.
4	Results from geochemistry of Lathrop Wells scoria sequences to Study 8.3.1.8.1.1.
5	Milestone Q114. Drilling completed on volcanism drillholes.
6	Drilling information to Study 8.3.1.8.1.1.
7	Milestones Z401, Z402, Z403, and Z404. Dating of volcanic deposits generally complete.
8	Results from dating of volcanic deposit to Study 8.3.1.8.1.1.

CONSULTATION DRAFT

<u>Point number</u>	<u>Description</u>
9	Milestone Z409. Report on geochemical cycles of basalt fields of the Great Basin available.
10	Results from geochemical cycles report to Study 8.3.1.8.1.1.
11	Milestone Z300. Report available on depth of Curie temperature isotherm.
12	Input from Curie temperature isotherm report to Study 8.3.1.8.1.1.
13	Milestone Z432. Report available on chemical and physical changes around dikes.
14	Results from chemical and physical changes around dikes to Studies 8.3.1.8.3.3 and 8.3.1.8.4.1.
15	Data on local heat flow anomalies available.
16	Results on local heat flow anomalies to Study 8.3.1.8.1.1.
17	Milestone Z302. Report available on evaluation of folds in Neogene rocks of the region.
18	Results from evaluation of folds in Neogene rocks of the region to Studies 8.3.1.17.4.5 (detachment faults) and 8.3.1.17.4.12 (tectonic models).

Nuclear Waste Policy Act
(Section 113)

Section 8.3.1.9

Consultation Draft

HUMAN INTERFERENCE

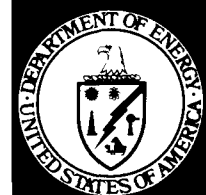

Site Characterization Plan

***Yucca Mountain Site, Nevada Research
and Development Area, Nevada***

Volume V

January 1988

U.S. Department of Energy
Office of Civilian Radioactive Waste Management
Washington, DC 20585

CONSULTATION DRAFT

8.3.1.9 Overview of the human interference program: Description of potential future human activities at or near the site, required by performance and design issues

Summary of performance and design requirements for human interference information

The postclosure human interference test program addresses (1) the likelihood of inadvertent human intrusion into a mined geologic disposal system (MGDS), (2) interference with long-term MGDS performance due to human activities, and (3) the possible consequences of such interference events. The likelihood of these events must be very low, because the potential consequences of events of this nature may pose unacceptable risks to the public health.

The performance and design requirements for the human interference program directly reflect the regulatory requirements of the NRC, the EPA, and the DOE. These requirements, and their relationships to the human activities program can be summarized as follows:

1. Issue 1.1 (total system performance, Section 8.3.5.13) requires information that can help in estimating the probability of human intrusion and interference during the postclosure period. This will be accomplished through the development of release scenarios. The development of these scenarios will focus on relating potential specific human activities to the specific effects on the variables of the system important to waste isolation. Thus, the human interference program will focus on identifying those factors that can affect the probability of future inadvertent human interference (i.e., the presence of potential economic resources at the site, and the long-term survivability of the surface markers), and describing qualitatively and quantitatively the effects of specific human activities.
2. Issue 1.8 (NRC siting criteria, Section 8.3.5.17) addresses NRC regulations 10 CFR 60.21(c)(13), 60.122(a), 60.122(c)(2), and 60.122(c)(17) requiring that resources at the site with current markets be identified, and described in terms of net and gross values. Resources that occur in abundances that may be marketable in the future must also be identified and described in terms of physical factors such as tonnage (or other amount), grade, and quality. The evaluation of resources, including undiscovered resources, shall be conducted for the site in comparison to areas similar to the site that are representative of and are within a similar geologic setting. A complete assessment of the potential consequences of exploration activities (e.g., drilling) or resource extraction that could realistically influence the ability of the MGDS to isolate waste during the postclosure period, is required. This would include identification of human activities such as ground-water withdrawal and fluid waste injection.
3. Issue 1.9 (higher level findings - postclosure system and technical guidelines, Section 8.3.5.18) is the evaluation of the site against

CONSULTATION DRAFT

the qualifying and disqualifying conditions of the DOE siting guidelines. For the site to be considered for selection as the first repository, it must be demonstrated that the site is located in an area such that natural resources at or near the site are not likely to give rise to interference activities. The presence of natural resources (whether known to be present or inferred to be present) could lead to exploration and exploitation activities by future generations that might affect long-term repository performance. Thus, information regarding the natural resource potential at and in the vicinity of the site will be obtained during the human activities program. The land ownership and mineral rights program (Program 8.3.1.11) addresses postclosure site ownership and control concerns, and discusses the only other qualifying conditions related to human interference.

4. Issue 4.4 (preclosure design and technical feasibility, Section 8.3.2.5) requires site-specific data for the design and placement of the permanent warning system. The warning system, which will consist of surface markers and monuments, will be placed along the boundary of the controlled area following repository closure and decommissioning. (The controlled area is the actual area chosen according to the 10 CFR 60.2 definition of controlled area.) Parameters relative to natural processes like erosion, deposition, ground motion, and burial by volcanic materials are required to identify the most suitable locations for the markers.

Approach to satisfy performance and design requirements

The consideration of inadvertent human intrusion or human interference events is based on several assumptions (10 CFR Part 60; 40 CFR Part 191, Appendix B). These assumptions, reproduced from the regulations, are as follows:

Processes and events initiated by human activities may only be found to be sufficiently credible to warrant consideration if it is assumed that (1) the monuments provided for by this part are sufficiently permanent to serve their intended purpose; (2) the value to future generations of potential resources within the site can be assessed adequately under the applicable provisions of this part; (3) an understanding of the nature of radioactivity, and an appreciation of its hazards, have been retained in some functioning institutions; (4) institutions are able to assess risk and to take remedial action at a level of social organization and technological competence equivalent to, or superior to, that which was applied in initiating the processes or events concerned; and (5) relevant records are preserved, and remain accessible, for several hundred years after permanent closure (10 CFR 60.2).

The [U.S. Environmental Protection] Agency believes that the most productive consideration of inadvertent [human] intrusion concerns those realistic possibilities that may be usefully mitigated by repository design, site selection, or use of passive controls (although passive institutional controls should not be assumed to

CONSULTATION DRAFT

completely rule out the possibility of intrusion). Therefore, inadvertent and intermittent intrusion by exploratory drilling for resources (other than any provided by the disposal system itself) can be the most severe intrusion scenario assumed by the implementing agencies. Furthermore, the implementing agencies can assume that passive institutional controls or the intruders own exploratory procedures are adequate for the intruders to soon detect, or be warned of, the incompatibility of the area with their activities. (40 CFR Part 191, Appendix B.)

The approach to assessing future human activities at Yucca Mountain will be consistent with the previously presented assumptions. The program will follow the principle that highly speculative intrusion scenarios will not be included, and that only those factors and potentially adverse human activities that could directly affect waste isolation will be addressed.

Human interference presents special problems because of its dependence upon unpredictable future human activities. This anthropogenic factor makes defining the potential for radionuclide releases resulting from human activities, in quantitative or probabilistic terms, particularly difficult. For this reason, professional judgment may be required (Study 8.3.1.9.3.1) to determine the likelihood of future human intrusion or interference that could result from resource exploration or extraction.

The general approach to obtaining the required parameters from the human interference program is to identify the natural and anthropogenic parameters that are required by the design and performance issues. Table 8.3.1.9-1 lists the performance issue that requests data from this program, along with the performance and characterization parameters required by the issue.

The data requirements of Issue 1.1 primarily involve quantifying, in probabilistic terms, the site-specific factors that could contribute to unanticipated natural phenomena or anthropogenic events at or in the vicinity of Yucca Mountain. Design of the marker system (Issue 4.4) requires site-specific data to ensure strategic placement of the monuments in locations having low risk associated with the consequences of natural phenomena or human activities. Archaeological studies of ancient monuments and structures (Kaplan, 1982; Berry et al., 1984) have been used to address identifiable and potentially disruptive and destructive anthropogenic factors that could affect marker survivability. The remaining parameters, the consequences of natural phenomena, will be obtained through other site activities and evaluated in Study 8.3.1.9.1.1 as listed in Table 8.3.1.9-1.

Current information and new data acquired from site activities will be employed to assess the natural resource potential of Yucca Mountain (Investigation 8.3.1.9.2). These data will be used to describe qualitatively the various categories of potential human interference and intrusion scenarios (Study 8.3.1.9.3.2). For example, the possible presence of four natural resources (i.e., mineral, geothermal, hydrocarbon, and ground-water resources) would require that at least one category of initiating events (exploratory drilling) must be evaluated. After examining the potential for

Table 8.3.1.9-1. Initiating events, associated performance parameters, and activity parameters for the human interference program (page 1 of 7)

Issue requesting parameter	SCP section	Initiating event	Performance parameter	Activity parameter	SCP section
1.1 Total system releases	8.3.5.13	Exploratory drilling intercepts a waste package and brings up waste with core or cuttings	Presence and readability of C-area ^a markers over 10,000 yr (long-term survivability of markers)	Rates of Erosion Weathering Deposition Igneous activity Seismic activity at marker locations	8.3.1.9.1
			Expected drilling rate (no. of boreholes/km ² /yr) in R-area ^b over the next 10,000 yr	Quantities, tonnages, and grades of known or inferred resources at Yucca Mountain	8.3.1.9.2.1
			Distribution of diameters of exploratory drilling	Types of known or inferred resources at Yucca Mountain	8.3.1.9.2 and 8.3.1.9.3
			Distribution of depths of exploratory drilling	Types of known or inferred resources at Yucca Mountain	8.3.1.9.2 and 8.3.1.9.3
		Extensive groundwater withdrawal occurs near C-area	Expected magnitude of change in water-table level in the C area due to extensive groundwater withdrawal in next 10,000 yr	Quantity, rates, well locations, and hydrostratigraphic unit sources of groundwater withdrawals	8.3.1.9.2.2 and 8.3.1.16.2.1

8.3.1.9-4

CONSULTATION DRAFT

Table 8.3.1.9-1. Initiating events, associated performance parameters, and activity parameters for the human interference program (page 2 of 7)

Issue requesting parameter	SCP section	Initiating event	Performance parameter	Activity parameter	SCP section
1.1 Total system releases (continued)	8.3.5.13 (continued)		Expected magnitude in changes in gradient of water table under C-area due to ground-water withdrawal near C-area in next 10,000 yr	Quantity, rates, well locations, and hydro-stratigraphic source of ground-water withdrawals	8.3.1.9.2.2 and 8.3.1.16.2.2
			Presence and readability of C-area markers over 10,000 yr	See the activity parameter for the exploratory drillers intercept under the initiating event column of this table	8.3.1.9.1.1
		Extensive surface or subsurface mining occurs near the C area	Expected magnitude of change in water-table level due to mine-water use or mine dewatering near C-area over next 10,000 yr	Estimated depth of mine, cross-sectional area of mines or shafts	8.3.1.9.3.2

8.3.1.9-5

CONSULTATION DRAFT

Table 8.3.1.9-1. Initiating events, associated performance parameters, and activity parameters for the human interference program (page 3 of 7)

Issue requesting parameter	SCP section	Initiating event	Performance parameter	Activity parameter	SCP section
1.1 Total system releases (continued)	8.3.5.13 (continued)		Expected magnitude of change in gradient under C-area due to mine-water usage or mine dewatering	Estimated water usage based on quantity of water available, depth of mine	8.3.1.9.3.2
			Expected magnitude of changes in distribution coefficient (K_d) of unsaturated zone (UZ) and saturated zone (SZ) due to mining activities near the C-area	No changes expected	8.3.1.9.3.2
			Presence and readability of C-area markers over next 10,000 yr	See the activity parameter for the exploratory drillers intercept under the initiating event column of this table	8.3.1.9.1.1

8.3.1.9-6

CONSULTATION DRAFT

Table 8.3.1.9-1. Initiating events, associated performance parameters, and activity parameters for the human interference program (page 4 of 7)

Issue requesting parameter	SCP section	Initiating event	Performance parameter	Activity parameter	SCP section
1.1 Total system releases (continued)	8.3.5.13 (continued)	Large-scale surface-water impoundments are constructed near the C-area	Expected magnitude of change in water table level due to presence of artificial lake near C-area	Area, depth, volume of surface-water impoundment; seepage rates, percolation rates and transmissivity of near-surface and subsurface materials	8.3.1.9.3.2
			Expected magnitude of changes in K_d^s for UZ and SZ units due to presence of an artificial lake near C-area	No changes expected	
			Expected magnitude of changes in head gradients of the SZ in C-area due to the presence of an artificial lake near C-area	Area, depth, volume of surface-water impoundments	8.3.1.9.3.2

Table 8.3.1.9 1. Initiating events, associated performance parameters, and activity parameters for the human interference program (page 5 of 7)

Issue requesting parameter	SCP section	Initiating event	Performance parameter	Activity parameter	SCP section
1.1 Total system releases (continued)	8.3.5.13 (continued)		Expected magnitude of flux change due to presence of an artificial lake near the C-area in next 10,000 yr	Area, depth, and volume of surface water impoundment; seepage rates, percolation rates, and transmissivity of near-surface and sub-surface materials	8.3.1.9.3.2
			Presence and readability of C-area markers over 10,000 yr	See the activity parameter for the exploratory drilling intercept under the initiating event column of this table	8.3.1.9.1.1
		Extensive irrigation is conducted near the C-area	Expected magnitude of change in altitude of water-table under C-area due to extensive irrigation near C-area over next 10,000 yr	Area of irrigation, crop cultivation, quantity of water used for irrigation based on quantity of water available	8.3.1.9.3.2

8.3.1.9-8

CONSULTATION DRAFT

Table 8.3.1.9-1. Initiating events, associated performance parameters, and activity parameters for the human interference program (page 6 of 7)

Issue requesting parameter	SCP section	Initiating event	Performance parameter	Activity parameter	SCP section
1.1 Total system releases (continued)	8.3.5.13 (continued)		Expected magnitude of flux change due to extensive irrigation near the C-area over next 10,000 yr	Area of irrigation, crop cultivation, quantity of water applied, infiltration, and percolation rate	
			Expected magnitude of change in read gradients below C-area due to extensive irrigation over next 10,000 yr	Quantity of irrigation withdrawals	8.3.1.9.3.2
			Expected magnitude of changes in K_d s of UZ and SZ	No change expected	8.3.1.9.3.2
			Presence and readability of surface markers over 10,000 yr	See the activity parameter for the exploratory drilling intercept under the initiating event column of this table	8.3.1.9.1.1

8.3.1.9-9

CONSULTATION DRAFT

Table 8.3.1.9-1. Initiating events, associated performance parameters, and activity parameters for the human interference program (page 7 of 7)

Issue requesting parameter	SCP section	Initiating event	Performance parameter	Activity parameter	SCP section
4.4 Technical feasibility	8.3.2.5	NA ^c	Surface markers located in geographically stable locations	Rates of erosion, deposition, igneous activity, and seismic activity near C-area boundary	8.3.1.9.1.1

^aC-area = controlled area, i.e., the actual area chosen according to the 10 CFR 191.12 definition of controlled area.

^bR = restricted area, i.e., the projection of the primary area and extensions onto the surface.

^cNA = not applicable.

CONSULTATION DRAFT

each resource, the probability of occurrence for each type of human intrusion scenario in the exploratory drilling category will be estimated. This will require the use of professional and expert opinion (Study 8.3.1.9.3.1). The probabilities obtained from this exercise will be provided to Issue 1.1, and will be used as input parameters in predicting potential radionuclide releases to the accessible environment.

The final information that will be obtained from the human activities program is an evaluation of the potential effects that could result from resource extraction. These data will be gathered under Investigation 8.3.1.9.3. Presently, only the effects of ground-water withdrawal on the hydrologic system will be evaluated because ground water is the only commodity currently identified as a resource. If other potentially marketable resources are identified during site characterization, plans will be developed to examine the effects of their extraction on the hydrologic, geochemical, and rock characteristics.

Interrelationships of human interference investigations

The first investigation (8.3.1.9.1) identified for this program determines all factors, both natural and anthropogenic, that could destroy or degrade the surface markers and monuments. Because the anthropogenic factors have been considered and incorporated into the marker design, only three specific data needs are identified, all of which will be provided from other investigations. The magnitudes and locations of fault rupture and seismically induced ground motion (Investigation 8.3.1.8.2); the rates, magnitudes, and locations of potential igneous activity (Investigation 8.3.1.8.1); and the potential effects of tectonic activity and future climatic conditions on locations and rates of erosion and deposition (Investigations 8.3.1.6.2 and 8.3.1.6.3, respectively) will aid in determining the best locations for the surface markers and monuments.

The second investigation (8.3.1.9.2) requires the identification of all resources at the site with current markets and an estimate of their gross and net value. Resources without current markets, but which are potentially marketable in the future, will be described in terms of such physical factors as tonnage (or other amount), grade, and quality. The evaluation of resources, including undiscovered resources, shall be conducted for the site in comparison to areas of similar size that are representative of and are within the geologic setting. The present assessment of commodities as presented in Chapter 1, Section 1.7 and reviewed in Section 1.8.1.7, classifies most commodities as "occurrences" and some as "undiscovered, speculative resources of subeconomic grade," using the USBM/USGS (1980) classification system. If identified resources and reserves are defined, they will be delineated and quantified (Study 8.3.1.9.2.1) and the impact of their presence will be addressed in Studies 8.3.1.9.3.1 and 8.3.1.9.3.2.

Ground water currently is the only commodity to be classified as a resource in the immediate vicinity of the site. Exploitation of this resource is expected to become economically feasible in the near future (DOI, 1985). Study 8.3.1.9.2.2 will integrate existing scientific and institutional data with information obtained during characterization of the saturated zone (Investigation 8.3.1.2.3) to (1) quantify and qualify the

CONSULTATION DRAFT

ground-water resources proximal to the site, (2) assess the current and future value of the resource, and (3) project the probable rates and locations of ground-water exploitation in the reasonably foreseeable future. These parameters (Table 8.3.1.9-1) will be considered in calculating the probability for human interference (Study 8.3.1.9.3.1) and in assessing the potential effects of ground-water exploitation on the conditions at the site (Study 8.3.1.9.3.2).

The final investigation (8.3.1.9.3) examines the potential effects of resource extraction on the baseline hydrologic, geochemical, and rock characteristics. The parameters that have been identified are the specific resources determined in Investigation 8.3.1.9.2, the conditions at the site and the extraction methods that would be used for the specific resources under consideration. The parameters obtained for this investigation will be analyzed and evaluated to determine whether the potential effects of resource exploitation can change the characteristics of the site such that repository performance would be affected. Professional judgment will then be used to define the interdependence between natural resources at the site and the potential for human intrusion as a result of exploratory drilling (Study 8.3.1.9.3).

The second part of Investigation 8.3.1.9.3 will focus on the initiating events of the release scenarios (Table 8.3.1.9-1) that relate to human interference, and their potential effects on long-term repository performance. The parameters defined for this investigation are (1) the initiating events identified in Issue 1.1 (total system performance) that may not be considered sufficiently credible to warrant further consideration because of the improbability of their occurrence (e.g., large-scale surface-water impoundment above the repository zone), and (2) those potential consequences of initiating events that are not expected to significantly affect long-term repository performance. These parameters will be evaluated to establish with a high level of confidence whether they are sufficiently credible or significant to warrant further consideration within Issue 1.1.

The information needed from the human interference program for the performance and design issues will be obtained from these three investigations. Table 8.3.1.9-2 lists the studies and activities that will be undertaken to obtain the required performance and design data. Figure 8.3.1.9-1 illustrates the relationships between the three investigations making up the human interference program and other issues that require input from this program.

The schedule information provided for information needs in this section includes the sequencing, interrelationships, and relative durations of the activities in the information need. Specific durations and start/finish dates for the activities are being developed as part of ongoing planning efforts and will be provided in the SCP at the time of issuance and revised as appropriate in subsequent semiannual progress reports.

CONSULTATION DRAFT

Table 8.3.1.9-2. Studies and activities making up the human interference program

Study	Activity	Description
8.3.1.9.1.1		An evaluation of natural processes that could affect the long-term survivability of the surface marker system at Yucca Mountain
	8.3.1.9.1.1.1	Synthesis of tectonic, seismic, and volcanic hazards data from other site characterization activities
	8.3.1.9.1.1.2	Synthesis--evaluation of the effects of future erosion and deposition on the survivability of the marker system at Yucca Mountain
8.3.1.9.2.1		Natural resource assessment of Yucca Mountain, Nye County, Nevada
	8.3.1.9.2.1.1	Geochemical assessment of Yucca Mountain in relation to the potential for mineralization
	8.3.1.9.2.1.2	Geophysical/geologic appraisal of the site relative to mineral resources
	8.3.1.9.2.1.3	Assessment of the potential for geothermal energy at and in the vicinity of Yucca Mountain, Nevada
	8.3.1.9.2.1.4	Assessment of hydrocarbon resources at and near the site
	8.3.1.9.2.1.5	Mineral and energy assessment of the site, comparison to known mineralized areas, and the potential for undiscovered resources and future exploration
8.3.1.9.2.2		Water resource assessment of Yucca Mountain, Nevada
	8.3.1.9.2.2.1	Projected trends in local and regional ground-water development, and estimated withdrawal rates in southern Nevada, proximal to Yucca Mountain
8.3.1.9.3.1		Compilation of data needed to support an assessment of the likelihood of inadvertent human intrusion at Yucca Mountain

CONSULTATION DRAFT

Table 8.3.1.9-2. Studies and activities making up the human activities program (continued)

Study	Activity	Description
	8.3.1.9.3.1.1	Compilation of data to support the assessment of the potential for inadvertent human intrusion at Yucca Mountain
8.3.1.9.3.2		An evaluation of the potential effects of exploration for or extraction of natural resources on the hydrologic characteristics at Yucca Mountain
	8.3.1.9.3.2.1	An analysis of the potential effects of future ground-water withdrawals on the hydrologic system in the vicinity of Yucca Mountain, Nevada
	8.3.1.9.3.2.2	Assessment of initiating events related to human interference that are considered not to be sufficiently credible or significant to warrant further investigation

8.3.1.9.1 Investigation: Studies to provide the information required on natural phenomena and human activities that might degrade surface markers and monuments

Technical basis for obtaining the information

Link to the technical data chapters and applicable support documents

Pursuant to the regulations of the EPA (40 CFR 191.14 (c)) and the NRC (10 CFR 60.21(c) and 60.51(a)), a warning system composed of surface markers and monuments will be placed at the site as a means of informing future generations of the risks associated with the repository and its contents. Human activities and many natural phenomena that could contribute to the degradation, destruction, or disruption of the marker system have been evaluated and presented in Kaplan (1982) and Berry et al. (1984). These factors have been considered and are being used as criteria in the final marker design. There are some site-specific natural processes and their consequences that require further consideration because of their potential to degrade, disrupt, or destroy the marker system. These processes are (1) potentially destructive fault displacement or seismically induced ground motion, (2) potentially destructive volcanic events or volcanic burial due to hydrovolcanic eruptions, and (3) increased erosion or deposition rates

**PERFORMANCE OR DESIGN
ISSUE CALLING FOR DATA**

**SITE
PROGRAM**

ANALYSIS AND ASSESSMENT

**KEY DATA COLLECTION
INVESTIGATION**

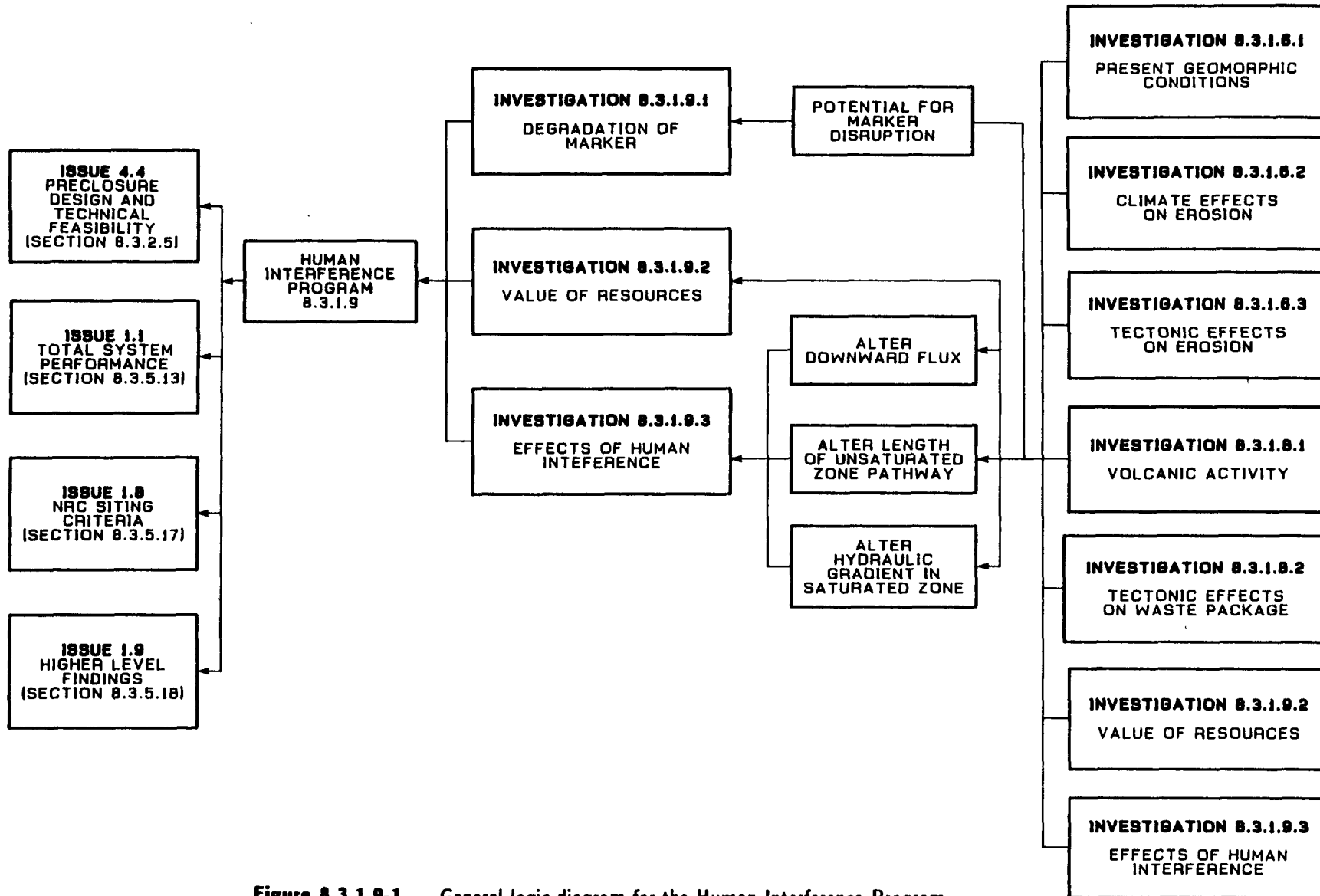

8.3.1.9-15

CONSULTATION DRAFT

Figure 8.3.1.9-1. General logic diagram for the Human Interference Program.

resulting from tectonic activity or climatic change. The current knowledge of these processes and their potential consequences as presented in Chapters 1, 3, and 5 of this document is not adequate to thoroughly assess the potential associated risks to the surface markers and monuments.

Parameters

Three parameters will be evaluated to resolve this portion of the investigation:

1. Potential fault movement and ground motion at the site from man-made natural seismic events (Investigation 8.3.1.8.2).
2. The rates and magnitudes of potential igneous activity that could affect the site (Investigation 8.3.1.8.1).
3. The potential effects of tectonic activity and future climatic conditions on locations and rates of erosion and deposition (Investigations 8.3.1.6.2, 8.3.1.6.3, and 8.3.1.5.1).

Purpose and objectives of the investigation

The purpose of Investigation 8.3.1.9.1 is to obtain the site-specific information on the occurrence and consequences of natural phenomena needed to satisfy the parameter requests of the performance and design issues. The objective of the investigation is to compile and evaluate these data so that they can provide information directly to the performance and design issues.

The information needed to satisfy Issue 1.1 is an estimate of the long-term survivability of the warning system. Data on the consequences of natural phenomena such as erosion, deposition, volcanic activity, and strong ground motion are needed to assess the possible damage to the warning system that might occur during the 10,000-yr postclosure period. The probability of inadvertent human intrusion and interference will be influenced by the effectiveness of the marker system to warn intruders of the potential hazards of the MGDS. Thus, bounds on the probability that the markers will be effective over the 10,000-yr postclosure period will provide input to the total system releases calculation.

Similar information is required by Issue 4.4 (preclosure design and technical feasibility) to supplement the general warning system design developed by the Office of Nuclear Waste Isolation (Kaplan, 1982). Geologic information gathered to assess the potential hazards associated with natural phenomena in the vicinity of the controlled area boundary will aid in determining the most suitable locations for the markers.

Investigation 8.3.1.9.1 ensures that the risks associated with natural phenomena are incorporated into the final design of the warning system. Figure 8.3.1.9-2 shows the flow of data for this investigation. By maximizing the effectiveness of the passive institutional controls, the likelihood that future generations will inadvertently affect the performance of the MGDS can be reduced.

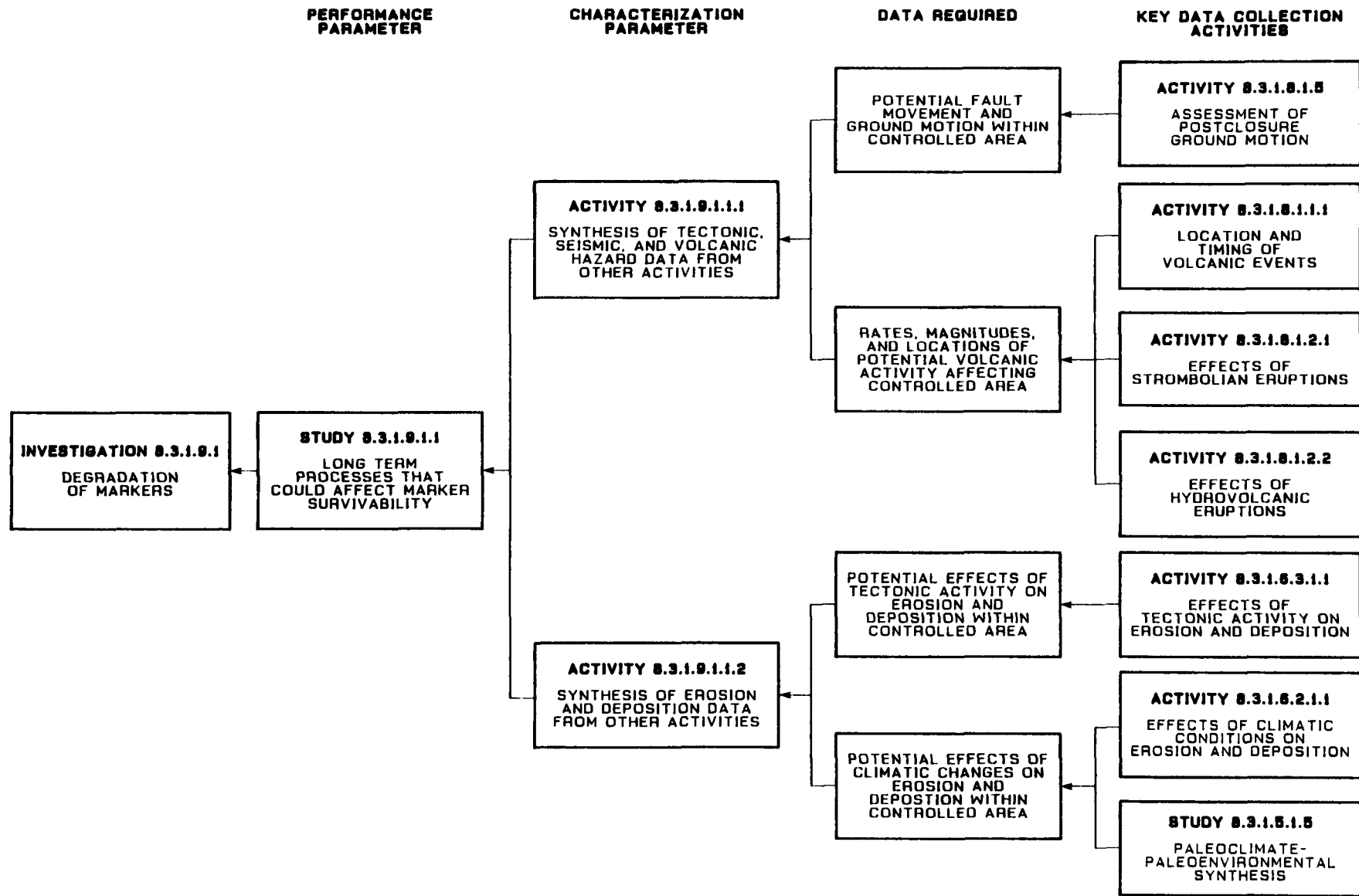

Figure 8.3.1.9-2. Logic diagram for Investigation 8.3.1.9.1.

Technical rationale for the investigation

Fault movement and ground motion at the site, whether from man-made or natural seismic events, could dislocate and damage large monuments and surface markers. Information regarding fault locations and the magnitudes of potential ground motions associated with fault rupture will aid in the placement and design of the surface marker system. Strategic placement of the markers will reduce the risk of their degradation or destruction.

Volcanic events could potentially degrade, cover, or destroy surface markers and monuments by dislocation, burial or incorporation into extruded volcanic material. Knowledge of the locations, rates, and magnitudes of potential volcanic events will aid in the placement of the markers and monuments, thereby reducing the associated risks.

Tectonic activity such as uplift or subsidence can increase erosion and deposition rates by changing the local or regional base level. Future climatic changes could potentially affect the locations and rates at which erosion and deposition occur. Erosion along the foundations of the markers could undermine their stability and result in dislocation. Deposition could result in rapid burial of the markers. Information regarding the locations and rates of potential erosion and deposition, which could contribute to marker dislocation or disruption, is needed to determine the most strategic placement of the markers and monuments.

Data that are required to satisfy the design and performance issues will be derived from studies done as part of Investigations 8.3.1.5.1, 8.3.1.6.2, 8.3.1.6.3, 8.3.1.8.1, and 8.3.1.8.2. The results obtained from these studies will be compiled and evaluated to determine the optimum locations for the surface markers.

8.3.1.9.1.1 Study: An evaluation of natural processes that could affect the long-term survivability of the surface marker system at Yucca Mountain

This study provides information on the currently or potentially active natural processes at Yucca Mountain capable of adversely affecting the long-term survivability of the surface marker system. This study will be a synthesis of data obtained from other activities to be undertaken in support of several investigations. The data will then be evaluated to determine the most suitable locations of the monuments for the surface marker system. Input for this study will be provided by Investigations 8.3.1.6.2, 8.3.1.6.3, 8.3.1.8.1, and 8.3.1.8.2. Detailed activity descriptions can be found under the appropriate investigation discussions.

8.3.1.9.1.1.1 Activity: Synthesis of tectonic, seismic, and volcanic hazards data from other site characterization activities

Objectives

The objective of this activity is to identify the potential locations of faulting and volcanic eruption or intrusion that could occur where they could affect the marker system.

Parameters

The parameters required for this activity will be derived from descriptions of the seismic, volcanic, and tectonic processes in the vicinity of the site and their associated physical consequences. These data will be taken from Studies 8.3.1.8.1.2 and 8.3.1.8.2.1.

Description

This activity will integrate all applicable data involving faulting, folding, uplift and subsidence, and volcanism. Each segment of the controlled area boundary will be examined in light of this information to determine the locations that have the lowest associated risk. The range of geologic consequences, as they might adversely affect the long-term survivability of the surface markers and monuments, will be described.

Methods and technical procedures

The methods and technical procedures for this activity are to be developed.

8.3.1.9.1.1.2 Activity: Synthesis: evaluation of the effects of future erosion and deposition on the survivability of the marker system at Yucca Mountain

Objectives

The objective of this activity is to determine the effects of future erosion and deposition on the topographic elements of the controlled area boundary at Yucca Mountain. This information will be evaluated to identify the optimum locations for the markers.

Parameters

The locations of potential future erosion surfaces identified in Activities 8.3.1.6.1.1.1 and 8.3.1.6.2.1.1 will be used as the input parameters for this activity.

Description

This synthesis activity will be aimed at identifying the locations along the controlled area boundary expected to have low rates of erosion and deposition during the postclosure period. Using this information in conjunction

CONSULTATION DRAFT

with results from volcanic and fault hazard analyses (Investigation 8.3.1.8.1) the tentative marker locations will be chosen.

Methods and technical procedures

The methods and technical procedures for this activity are to be developed.

8.3.1.9.1.2 Application of results

The data obtained from this study will be used to determine the most suitable locations for the surface markers and monuments. The strategic placement of the surface markers and monuments at locations unlikely to experience physical disruptions as a result of natural processes will contribute to the long-term stability of the warning system. The final locations chosen for the surface markers will be identified and evaluated in a milestone report. This report will provide input regarding marker survivability to Issue 1.1 (total system performance), which will be used in assessing the human interference scenarios.

8.3.1.9.1.3 Schedule and milestones

This investigation contains one study: 8.3.1.9.1.1 (long-term processes that could affect marker survivability). In the figure that follows, the schedule information for this study is presented in the form of a timeline. The timeline extends from implementation of the approved study plan to the issuance of the final products associated with the study. Summary schedule and milestone information for this investigation can be found in Section 8.5.1.1.

The study in this investigation is an out-year study, and its completion is constrained by the availability of data from other investigations (see figure in Investigation 8.3.1.9.2).

The basis of this investigation is acquiring and evaluating data to provide the information required on natural phenomena and human activities that might degrade surface markers and monuments. Synthesis of tectonic, seismic, volcanic hazard, erosion, and deposition data will determine the survivability of the marker system.

The study number and title corresponding to the timeline are shown on the left of the following figure. The points shown on the timeline represent major events or important milestones associated with the study. Solid lines represent study duration, and dashed lines show interfaces. The data input and output at the interfaces are shown by circles.

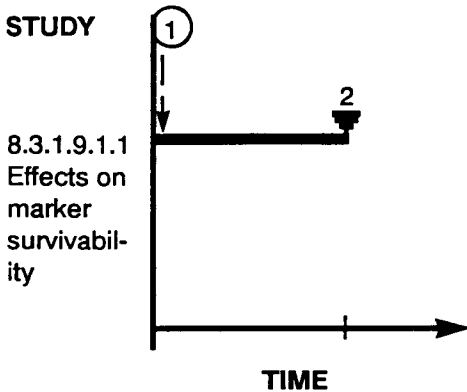

The points on the timeline and the data input and output at the interfaces are described in the following table:

<u>Point number</u>	<u>Description</u>
1	Data input from studies examining volcanic eruption and repository igneous intrusion, waste package, and modern regional climate (8.3.1.8.5 and 8.3.1.5.1.1) and activities examining potential impacts of tectonic activity on erosion and potential impacts of future climate on erosion (8.3.1.6.3.1.1 and 8.3.1.6.2.1.1).
2	Milestone Z472. Issue report synthesizing the natural processes that could affect marker survivability.

8.3.1.9.2 Investigation: Studies to provide the information required on present and future value of energy, mineral, land, and ground-water resources

Technical basis for obtaining the information

Link to the technical data chapters and applicable support documents

A preliminary assessment of the natural resource potential at Yucca Mountain (energy, mineral, ground water, and land), based on published literature, was presented in the Yucca Mountain environmental assessment (DOE, 1986b). Sections 1.7 and 1.8.1.7 (Summary) of the SCP provide additional information and an evaluation of the mineral and energy resources for the site. Section 3.8 of the SCP contains a preliminary assessment of the ground-water resources in the relevant geohydrologic basins at and in the vicinity of Yucca Mountain. Land resources have been evaluated in Sections 3.4 and 6.2 of the Yucca Mountain environmental assessment (DOE, 1986b).

CONSULTATION DRAFT

Parameters

Several groups of parameters must be evaluated to determine all the factors that must be considered when assessing the future value of potential resources at Yucca Mountain. These groups of parameters include the following:

1. The assessment for the occurrences of economically attractive deposits of precious metals, base metals, strategic metals, industrial minerals, or other commodities, and energy resources including hydrocarbon or geothermal resources.
2. The projected value and future development of local ground-water resources.

Purpose and objectives of the investigation

The natural resource potential of a candidate site for an MGDS is an important consideration in evaluating the likelihood for inadvertent human intrusion and interference. The presence of natural resources or an environment that is favorable for the occurrence of natural resources could lead to exploration within or near the controlled area, and possible subsequent resource exploitation. The exploration or extraction of resources could result in direct releases of radionuclides to the accessible environment or could modify the hydrologic, geochemical, and rock characteristics at the site (Investigation 8.3.1.9.3) by possibly shortening travel paths to the accessible environment. Thus, a complete evaluation of the natural resource potential of the Yucca Mountain site is essential in determining the likelihood for inadvertent human intrusion and interference.

Technical rationale for the investigation

The potential occurrence of precious- and base-metal deposits, other metallic or nonmetallic deposits, and geothermal or hydrocarbon resources at Yucca Mountain will play an important role in determining the likelihood for future exploratory drilling within the boundaries of the controlled area. This knowledge will provide the basis for Investigation 8.3.1.9.2 as outlined in Figure 8.3.1.9-3, and additionally will provide input to Investigation 8.3.1.9.3 by identifying those resources that may attract exploration or may potentially be exploited, and thus could affect the long-term waste isolation ability of the Yucca Mountain site. Figure 8.3.1.9-3 shows the flow of data for this investigation.

To assess the potential for resource exploration or exploitation over the next 10,000 yr, it will be necessary to identify all resources at the site with current markets and provide an estimate of their gross and net values. Resources without current markets, but which could potentially be marketable in the future, will be described in terms of physical factors such as tonnage (or other amount), grade, and quality. The discussion of commodities, as presented in Section 1.7 and reviewed in Section 1.8.1.7, classifies most commodities as "other occurrences" and some as "undiscovered, speculative resources of subeconomic grade," using the USBM/USGS (1980) classification system. It is extremely unlikely that drilling or mining will occur in the area unless commodities that are presently valued or may be valued in the

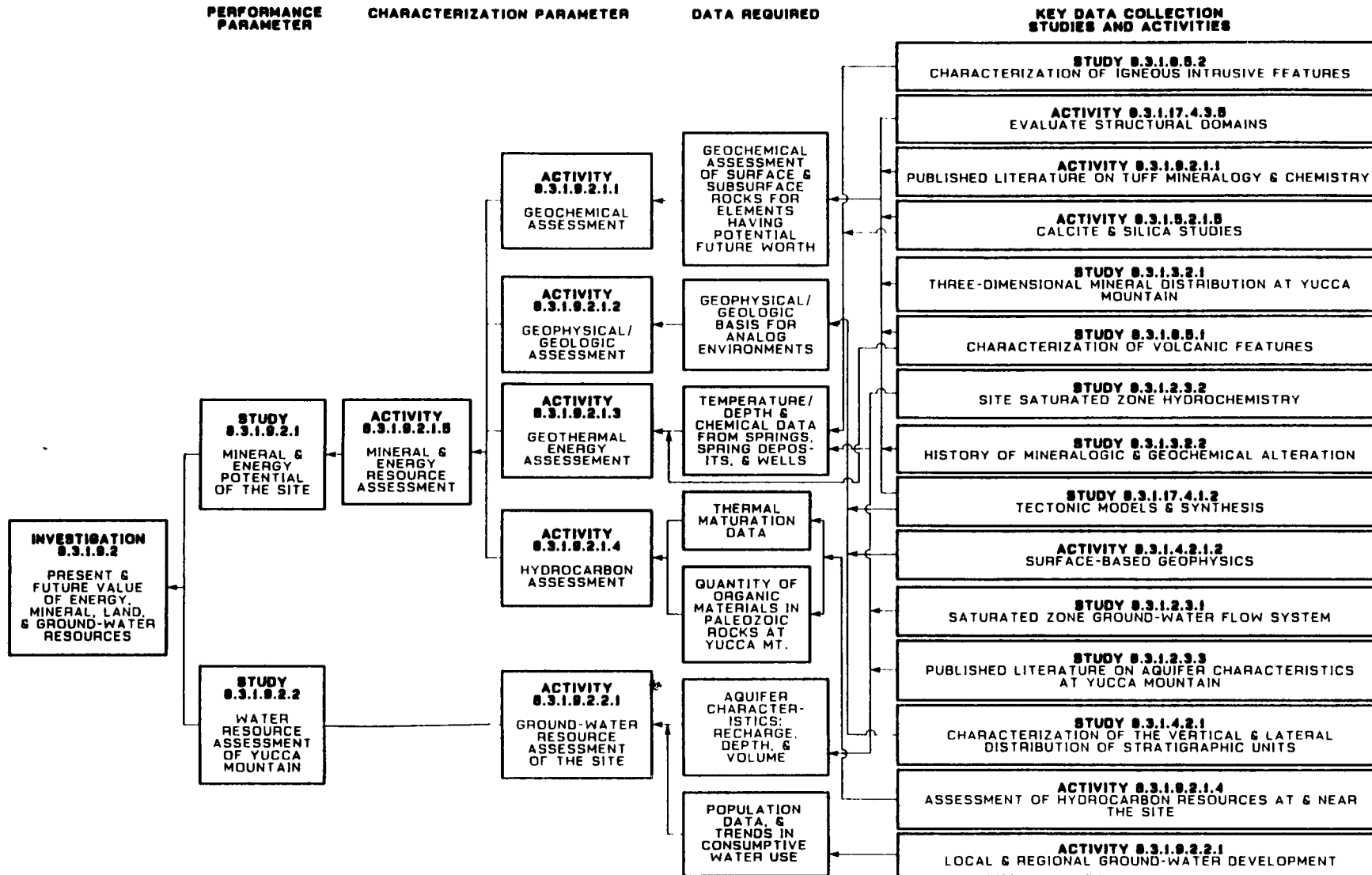

CONSULTATION DRAFT

Figure 8.3.1.9-3. Logic diagram for Investigation 8.3.1.9.2.

CONSULTATION DRAFT

future are found in amounts that greatly exceed the average crustal abundance (Section 1.7). Identified resources and reserves will be delineated and quantified (Study 8.3.1.9.2.1) and the impact of their presence will be addressed in Studies 8.3.1.9.3.1 and 8.3.1.9.3.2.

The relative value of the ground-water resources that are located proximal to the site is known to be low at the present time. The depth to these resources, and the distances over which transport would be required, currently preclude economic exploitation. Through time, these economic conditions may change, and ground-water development and exploitation may occur as a result. As discussed in the previous section, ground-water development and exploitation proximal to the site could affect the geo-hydrologic system. Such effects must be evaluated in Investigation 8.3.1.9.3. The projections of the probable future withdrawal rates that will be obtained from activities conducted in support of this investigation will be used as an input parameter for Investigation 8.3.1.9.3.

Sections 3.4 and 6.2 of the environmental assessment for Yucca Mountain (DOE, 1986b) suggest that the use of the land surface as a resource is highly unlikely for the following reasons:

1. The sparse vegetation within the boundaries of the controlled area has historically precluded this land from being used for grazing purposes. Other, better-suited areas are available nearby and throughout southern Nevada that would likely be preferred in the future.
2. Community settlement historically has occurred within valleys where water resources are more accessible. Yucca Mountain and the surrounding controlled area are physiographically poorly suited for community development because of the rough terrain, the absence of surface water, and the great depth to ground water.
3. There is low potential for agricultural development within the boundaries of the controlled area because of the poorly developed soils, the lack of surface water, the depth to ground water, and the variable topographic relief.

The scarcity of vegetation, wildlife, and water has historically precluded using the land within the controlled area for recreational purposes. Thus, based on the historical use of this land, there is little chance that it will ever be considered suitable for recreational use. Information will be used from climate prediction studies (Section 8.3.1.5.1.6) to assess the value of the land within the proposed controlled area. A topical report will be prepared that addresses present and future land use in the Yucca Mountain area. This topical report will be prepared in response to the human interference program, the NNWSI Project environmental programming planning efforts, and the environmental impact statement process, as required for the repository construction and operation phases of the Project.

The probability that natural resources occur at the Yucca Mountain site is a required input parameter for evaluating the probability that future exploratory drilling will occur. This probability will be evaluated by an

CONSULTATION DRAFT

expert panel and incorporated into a subjective probability that describes the likelihood of future exploratory drilling (Study 8.3.1.9.3.1).

Two studies are planned to address Investigation 8.3.1.9.2. The studies consist of activities designed to obtain data from the existing literature and from site characterization. Through these activities, an evaluation will be made of (1) the geochemical characteristics of the site (Activity 8.3.1.9.2.1.1), (2) the geophysical-geologic characteristics of the site (Activity 8.3.1.9.2.1.2), (3) the potential for future occurrences of geothermal resources in the vicinity of Yucca Mountain (Activity 8.3.1.9.2.1.3), (4) the potential for hydrocarbon resources at the site (Activity 8.3.1.9.2.1.4), and (5) a summary assessment of the mineral and energy potential of the site (Activity 8.3.1.9.2.1.5).

8.3.1.9.2.1 Study: Natural resource assessment of Yucca Mountain, Nye County, Nevada

This study will identify and assess the natural resource potential at the proposed repository site at Yucca Mountain. Mineral and energy resources (including hydrocarbon and geothermal resources) will be included. Water resources will be evaluated under Study 8.3.1.9.2.2. The study includes a geochemical assessment of Yucca Mountain in relation to the potential for mineralization (Activity 8.3.1.9.2.1.1), a geophysical-geologic appraisal of the site relative to mineral resources (Activity 8.3.1.9.2.1.2), an assessment of the potential for geothermal energy at and in the vicinity of Yucca Mountain (Activity 8.3.1.9.2.1.3), an assessment of the hydrocarbon resources of the site (Activity 8.3.1.9.2.1.4), and a mineral and energy assessment of the site, comparison to known mineralized areas, and the potential for undiscovered resources and future exploration (Activity 8.3.1.9.2.1.5). The information and data obtained in this study will provide the basis for probabilistic calculations for determining inadvertent human interference and intrusion (Study 8.3.1.9.3.1).

Mineral and energy resources have been discussed in Sections 1.7 and 1.8.1.7 and will be further assessed in this program. This includes information that will allow the calculation of gross and net values for any identified resources and reserves that have present markets, and the calculation of tonnage, grade, or volume for speculative, undiscovered resources (Section 1.7) that may have value in the future. These data will then be used as input to Issue 1.1.

8.3.1.9.2.1.1 Activity: Geochemical assessment of Yucca Mountain in relation to the potential for mineralization

Objectives

The overall objective of this activity is to conduct a geochemical sampling program to evaluate the potential for precious, base, and strategic metals; energy resources; and industrial mineral resources in the vicinity of Yucca Mountain. Specific objectives include:

CONSULTATION DRAFT

1. Selecting a suite of elements for analysis in a geochemical sampling program. The suite will be based upon known commodities that occur in silicic tuffs and/or trace elements indicative of commodities that occur in the tuffs.
2. Developing a field program to include a systematic and biased sampling of surface materials. Using existing core, core obtained during site characterization, and other subsurface samples to evaluate the potential of mineralization at and near the site.
3. Generating a first-order geochemical data base for selected elements obtained from surface and subsurface sampling within the vicinity of Yucca Mountain.
4. Evaluating the data base in conjunction with geological and geophysical data obtained from other site characterization activities to determine if additional data are needed for an evaluation of natural resources.
5. Evaluating the potential for the occurrence of natural resources in the vicinity of Yucca Mountain based on an analysis of the geochemical data. These data will be examined and evaluated statistically from anomaly and residual maps, and by comparison with calculated background levels and average elemental values found in silicic tuffs.

Information obtained from this activity will further address questions concerning the attractiveness of the site relative to the possible presence of resources (Activity 8.3.1.9.2.1.5) and the potential of future drilling or disruption (Study 8.3.1.9.3.1).

Parameters

The following list is considered to be a first approximation of the elements that are currently important commodities in silicic volcanic associations: gold, silver, copper, lead, zinc, mercury, thorium, and uranium. In addition, pathfinder elements may be considered and could include antimony, fluorine, barium, arsenic, and yttrium. Existing chemical analyses on the tuffs of Yucca Mountain will also be used in the site geochemical assessment. Additional elements that could be assessed or analyzed, if necessary, will be determined from a literature search and evaluation of the mineralogy and chemistry of tuff.

Description

Geochemical sampling of surface and subsurface materials will be conducted to determine the potential for exploration in the area of the repository. It is anticipated that future exploration for mineral commodities would likely be conducted before activities such as drilling or mining (Section 1.7). On the basis of currently available data and regional comparisons (Sections 1.7 and 1.8.1.7), the mineral-resource potential of the site is considered low, although certain commodities are viewed as having a slightly greater likelihood of occurrence. Chemical analyses of surface and subsurface samples could add further confidence to the conclusion that

CONSULTATION DRAFT

adjacent areas with surface and subsurface anomalies (e.g., Wahmonie, Calico Hills, Bare Mountain) would prove to be more likely locations for future drilling and mining (Section 1.7.1.1). A geochemical data base would help to determine if the site is likely to remain unattractive for exploration, even with anticipated changes in exploration methods and concepts.

The approach to the geochemical sampling program and Activity 8.3.1.9.2.1.5 will be based on a review of existing literature of similar geologic environments with known mineral occurrence, data from preliminary geochemical analyses (Section 1.7), the geologic setting of Yucca Mountain, and the nearby mineralized areas (Bare Mountain, Wahmonie, and Calico Hills). A comparison of the suite of elements determined for Yucca Mountain will be compared with proposed ore emplacement models found elsewhere in the literature. The geochemical sampling scheme to be developed will account for subsurface and surface variation in terrain, rock type, or soil type. The elements selected for analysis will be those that represent metallic and nonmetallic commodities known to be associated with silicic volcanic rocks. Geochemical sampling also will include rocks of various types and rocks exhibiting the effects of alteration or other geological phenomena commonly associated with mineralization. A geological deposit that will be included in this activity includes calcite and opaline silica deposits or breccias located along faults (Section 8.3.1.5). The sampling program will not be restricted to the controlled area. Samples will also be collected and analyzed from northern Yucca Mountain, Calico Hills, and Wahmonie. This will provide a comparative base, along with chemical analyses obtained from the available literature, to compare the site with other areas in Activity 8.3.1.9.2.1.5.

The configuration for the surface sampling program, including a number of sample locations, will be based on the geology, known and expected mineral occurrences, topography, and configuration of the perimeter drift and controlled area. A systematic sampling system will be used. Sample spacing within the controlled area is expected to range between 250 and 750 ft. A more closely spaced grid system may be necessary for a second-order geochemical sampling program if anomalies are identified from the first-order program. Surface sampling will not be restricted to the grid system. Biased sampling will also be done where rock types and alteration zones or other geological phenomena commonly associated with mineralization are observed. In addition, sediment sampling within selected areas, including drainages, may be necessary at similar spacing (250 and 750 ft).

The subsurface sampling program will be carried out in a similar manner. A representative number of drillhole cores will be selected that uniformly (depending on availability of core) cover the controlled area. Spacing of sampling locations of the core is expected to range between 50 and 300 ft. The program is intended to include the deep holes, including UE-25p#1, which intersect the Paleozoic rocks under Yucca Mountain. Biased samples will be taken from rock types and alteration zones commonly associated with mineralization. Additional sampling may be necessary if anomalies are identified.

Sampling intervals at the surface and of drillhole core will vary depending upon the particular element being measured. For instance, gold will require a more closely spaced sampling interval than base metals.

CONSULTATION DRAFT

Sampling intervals will be determined after a complete list of elements selected for analysis is finalized and a scoping assessment is made for each element.

Anomaly and residual maps will be prepared for each elemental analysis. Standard statistical analyses will be performed to characterize the background levels and spatial variability for each element, including averages and standard deviations of the results of the analyses. A comparison of background levels found in the silicic tuffs of Yucca Mountain with anomalies identified will be made. In addition, average elemental abundances found in silicic tuffs will be compared with elemental abundances found at Yucca Mountain.

This activity will generate a geochemical data base for two groups of elements. The first group will include those elements with known affinities for silicic volcanic rocks, including elements that are concentrated by primary magmatic processes, secondary weathering, or hydrothermal (mesothermal to epithermal) processes. The precious metals (gold and silver), mercury, and uranium are included in this group. The second group, the so-called pathfinder elements, such as antimony and arsenic, are usually subeconomic. Because of their solubility in alteration processes, however, these elements are useful in defining dispersion halos or detecting emanations from more deeply buried mineral deposits. Elements such as mercury are important as commodity elements (group 1) and are also excellent pathfinder elements (group 2).

Many elements can be excluded from this evaluation based on their known abundances and potential concentration factors in crustal rocks. These include cobalt, chromium, and the platinum group elements, which are known only to be associated with mafic and ultramafic rocks (Stanton, 1972). Additionally, a large body of literature exists relative to the distribution of elements in specific rock types that allow the prediction of which elements could occur in anomalous concentrations by such processes as weathering, hydrothermal activity, or magmatism. Therefore, many additional commodities and elements may be eliminated from further consideration.

Analytical methods to be used may include fire assays, atomic absorption, x-ray diffraction, x-ray fluorescence, neutron activation, or inductively coupled plasma emission spectroscopy. These methods will be evaluated based on their analytical detection limits and the projected number of samples to be analyzed.

Methods and technical procedures

The methods and technical procedures for this activity are given in the following table.

CONSULTATION DRAFT

Method	Technical procedure		
	Number	Title	Date
Geochemical sampling plan	TBD ^a	TBD	TBD
Analytical methods	TBD	TBD	TBD
Field methods	TBD	TBD	TBD

^aTBD = to be determined.

8.3.1.9.2.1.2 Activity: Geophysical/geologic appraisal of the site relative to mineral resources

Objectives

This activity will qualitatively evaluate the available geophysical data base as it relates to Study 8.3.1.9.2.1. The existing geophysical data base (Section 1.7.1.1) will be examined to define any geophysical anomalies that may require additional exploration and possibly constrain any known geochemical anomalies (Activity 8.3.1.9.2.1.1). The geophysical data base will also be used as a basis for comparisons to analog environments of known mineralization (Activity 8.3.1.9.2.1.5). Geologic models derived from geophysical data in Section 8.3.1.17 will be evaluated for their impact on mineral resources. Further work may be planned depending on the results of studies described in Section 8.3.1.17.4 and the qualitative evaluation performed in this activity.

Parameters

Existing regional and site-specific reports on geophysical surveys, as well as reports from geophysical work planned in Section 8.3.1.17.3 will be used in this qualitative assessment. Included in this assessment will be a review of the existing aeromagnetic, gravity, and electrical (induced polarization and magnetotelluric) data. Data obtained from the site-specific gravity, ground magnetic, selected geophysical logging, and magnetotelluric surveys (Section 8.3.1.17.4.3) may also be assessed. Possible hydrothermal alteration zones may be identified through the use of remote sensing (thematic mapper) and field mapping (Section 8.3.1.17.4.4). These techniques may provide useful information to the geochemical program (Section 8.3.1.9.2.1). Additional parameters may be defined during this activity.

Description

Interpretations described in the literature and derived from geophysical data may provide additional information to evaluate the geochemical data base (Activity 8.3.1.9.2.1.1) and to aid in determining which types of ore-forming models should be considered. In addition, preliminary geophysical models

that have been suggested for Yucca Mountain include the possible presence of detachment faults (Scott, 1986; Scott and Rosenbaum, 1986), and the presence of a metamorphic core complex under Yucca Mountain (Robinson, 1985). These interpretations, if correct, will be assessed relative to their significance to ore-forming processes.

Other geophysical methods (Section 8.3.1.17.4) that are responsive to local, surficial, or shallow variations of the bedrock will be evaluated as potential complements possibly to constrain the site-specific geochemical survey (Activity 8.3.1.9.2.1.1). The information and data evaluated in this activity will provide the geophysical basis for the comparisons to analog environments performed in Activity 8.3.1.9.2.1.5.

Methods and technical procedures

There are no procedures for Activity 8.3.1.9.2.1.2. Existing data will be used.

8.3.1.9.2.1.3 Activity: Assessment of the potential for geothermal energy at Yucca Mountain, Nevada

This activity will be undertaken in cooperation with Activity 8.3.1.8.5.2.3 (evaluation of regional ambient heat flow and local heat flow anomalies). Both activities are aimed at characterizing the local geothermal regime as it might relate to repository performance during the postclosure period. Activity 8.3.1.8.5.2.3 will focus on geothermal activity as it might relate to Quaternary volcanism. This activity (8.3.1.9.2.1.3) assesses the geothermal regime in terms of its energy resource potential. Data compilation and evaluation will be done jointly through both activities.

Objectives

The overall objective of this activity is to assess the potential for a geothermal energy resource at Yucca Mountain, Nevada.

The objectives of this activity are to

1. Compile measured geothermal and calculated heat flow data at and in Yucca Mountain and vicinity to quantify vertical and horizontal geothermal gradients. The quality of these data will be assessed under this activity in conjunction and cooperation with Activity 8.3.1.8.5.2.3. Temperature and other data collected under site unsaturated zone hydrology (Section 8.3.1.2.2) and site saturated zone hydrology (Section 8.3.1.2.3) will be assessed here and in cooperation with Activity 8.3.1.8.5.2.3.
2. Compile appropriate chemical and isotopic (oxygen and deuterium) analyses of water samples from springs and wells useful for predicting subsurface temperatures. These data will be useful in comparing subsurface temperatures at the site with measured temperature profiles and heat flow data for the region.

CONSULTATION DRAFT

3. Evaluate the existing data on geothermometry and heat flow necessary to adequately characterize the region for its geothermal resource potential.
4. Recommend whether additional studies may be needed, including the collection of additional geothermal data from existing or planned drillholes.
5. Provide the information necessary for the final resource assessment to be performed in Activity 8.3.1.9.2.1.5.

Parameters

The parameters that will be calculated and evaluated for this activity are

1. Downhole temperature gradients, thermal conductivity, data of core and samples from the exploratory shaft facility, geothermal gradient data, and thermal conductivity data will be used to calculate heat flow (Sections 8.3.1.8.5.3, 8.3.1.17.4.5, and 8.3.1.8.5.2).
2. Water chemistry and isotopic (oxygen and deuterium) analyses will be used in evaluating geothermometry methods (Study 8.3.1.2.3.2).
3. Temperature of ground water from springs and wells, and geological, hydrological, and structural data of the site and surrounding region will be used to assess the geothermal energy potential of Yucca Mountain (Section 8.3.1.2.3.2, 8.3.1.4.2.1, and 8.3.1.8.5.2).

Description

As discussed in Section 1.7.1.5.3, the existing heat flow calculations, temperature data, temperature gradient data, and isotopic analyses (oxygen and deuterium) for Yucca Mountain are consistent with a low-temperature (<90°C) geothermal regime.

Downhole temperature data from Yucca Mountain and temperature data obtained from nearby localities indicate that significant variations occur in temperature gradients for a single hole and between wells. Anomalous heat flow and thermal gradients are observed at localities near the site at drillhole UE-25a#3 (3.08 to 3.34 heat flow units (HFU)) located near Calico Hills, and drillhole UE-20F located at Pahute Mesa (thermal gradient is 37°C/km). These localized anomalies could be associated with water circulation in faults, shallow magma bodies, anomalous ground-water flow, and large variations in stratigraphic thickness (thermal conductivity).

The available data for geothermal assessment have not been compiled or thoroughly evaluated for adequacy or quality. Because data were not collected systematically (in some instances, measurements were taken during or soon after drilling (Sass et al., 1983)), some of the data are of questionable quality. Thus, the available data will be evaluated for their adequacy and quality, and the acquisition of temperature and thermal conductivity data from existing or new drillholes for use in heat flow calculations may be recommended as a result of this activity. A compilation of regional data

CONSULTATION DRAFT

obtained from the literature will also be assessed so that a comparison can be made with the data from the Yucca Mountain area.

Chemical and isotopic data will be compiled and evaluated for their application to the geothermal assessment of Yucca Mountain. Data will include chemical analyses of ground-water samples obtained from drillholes (Section 8.3.1.2.3.2), and springs near Yucca Mountain. These data will be evaluated to determine whether silica geothermometer analyses may be appropriate.

All the data compiled and evaluated will be used in conjunction with geologic, structural, stratigraphic, and hydrologic data to perform the geothermal assessment. This activity will lead into the final energy and resource assessment performed in Activity 8.3.1.9.2.1.5.

Methods and technical procedures

There are no methods and technical procedures for this activity. Existing data and data collected in support of other site characterization activities will be used.

8.3.1.9.2.1.4 Activity: Assessment of hydrocarbon resources at and near the site

Objectives

The objectives of this activity are to

1. Determine the potential for occurrence of conventional hydrocarbon resources (crude oil and natural gas) at and near the site.
2. Determine the potential for the presence or absence of suitable source rocks, reservoir rocks, and traps and seals at and near the site in the course of pursuing the first objective of this activity.
3. Provide necessary data for the overall mineral and energy resource assessment to be performed in Activity 8.3.1.9.1.5.

Parameters

Several investigative efforts and evaluation approaches are intended. First, the presence of organic matter within certain Paleozoic rocks will be ascertained. This will be based upon an examination of samples from drillholes and outcrops in the general area including core material from the one drillhole (UE-25p#1) that penetrated Paleozoic rocks close to the site. Newly obtained core or cuttings from drillholes in areas adjacent to the site will also be studied. An evaluation of the existing petroleum industry exploration drillholes in the vicinity of Yucca Mountain will be made to determine if information relevant to the site can be obtained. Outcrop material from adjacent areas such as Bare Mountain, Calico Hills, and Mine Mountain-Syncline Ridge will also be collected and evaluated.

CONSULTATION DRAFT

Second, the thermal maturation of any organic matter found in these samples will be determined. Several techniques, such as kerogen elemental analysis, kerogen coloration (temperature alteration index (TAI)), rock pyrolysis, and vitrinite reflectance, are among those available for determining thermal maturation-source-bed potential. These and possibly other techniques that are based upon organic matter will be compared relative to their applicability, especially with regard to outcrop samples using the most suitable method(s).

Third, parallel consideration of another thermal maturation technique, based upon microfaunal remains (conodonts) and termed the conodont color alteration index (CAI), will be undertaken in conjunction with a literature search intended to focus upon the thermal maturation experienced by the Paleozoic carbonate strata at and near the site. This will allow refinements to be made to the estimate of Lopatin's time-temperature index (Section 1.7.2.2.1) and will expand upon the work of Harris et al. (1980) and M. D. Carr et al. (1986). This will also allow the anticipated integration of the thermal history of adjacent sites (e.g., Bare Mountain) into an understanding of the thermal history of Yucca Mountain.

Other work is intended to review the stratigraphy and geologic structure of the Yucca Mountain site and of areas near the site within the context of available and future drillhole and geophysical data (Section 1.7.1.1; Study 8.3.1.17.4.4). This is intended to identify potential reservoir rocks, traps, and seals that may be present. An allied exercise will be to evaluate comparable petroleum-geology features as they are developed at known hydrocarbon occurrences within the Great Basin of Nevada, and, in particular, the highly productive trend that is present in the Railroad Valley area (e.g., Grant Canyon Field) of northeastern Nye County. This will provide a basis for assessing the degree to which these factors are relevant to the petroleum potential of the site (Activity 8.3.1.9.2.1.5). New data gathered by several planned geophysical surveys, such as the regional magnetotelluric, deep refraction-seismic, deep and intermediate reflection-seismic, and the ground magnetic surveys planned for fault detection (Table 8.3.1.17-8) will be assessed if applicable for evaluating oil or gas potential. Part of this effort will be conducted under Activity 8.3.1.9.2.1.2, particularly the evaluation of geophysical data, which will include an early assessment regarding the applicability of these data to the interpretation of subsurface geologic structures. Additional parameters may be defined and pursued if these several work efforts, evaluations, and literature investigations fail to provide adequate information on possible source rocks-organic matter, thermal maturation, and the integrated petroleum potential at and near the site. Among these may be a comparative evaluation of both surface hydrocarbon-prospecting techniques and indirect subsurface detection methods such as the analysis of ground water for dissolved hydrocarbon gases.

Description

To date, no hydrocarbons have been discovered at or in the vicinity of the Yucca Mountain site, although relatively few boreholes have been drilled for that purpose. Of the commercially drilled exploration holes located throughout southcentral and southeastern Nevada, none have encountered economic quantities of oil and gas. Significant shows of such hydrocarbons have similarly been lacking.

CONSULTATION DRAFT

The thermal history of the general Yucca Mountain area may have been too high over an extended period of geologic time to allow any previously formed hydrocarbons to persist as either oil or gas (Section 1.7.2.2.1). However, data presented by M. D. Carr et al. (1986) suggest that CAI-based temperatures within the Silurian portion of the Paleozoic carbonate sequence as encountered in drillhole UE-25p#1 have been no greater than 180°C, and possibly no less than 140°C (CAI = 3). If these paleogeothermal data represent an accurate reflection of the thermal maturation, these rocks would not be considered overly mature, and thus technically capable of some hydrocarbon potential within the gas range, provided that the several other factors necessary to generate and entrap hydrocarbons were present.

Further refinement of the thermal history will be pursued, along with work designed to evaluate the potential for reservoir rocks, the potential for trap-seals, and the comparison with other producing trends within the Great Basin and Nevada. Analyses of any detected organic matter (as found in drillhole cores and cuttings and samples collected from selected outcrops) will be made based upon an assessment of the most applicable petroleum geochemical methods. Companion work based upon faunal remains and their indications of thermal maturation will also be made. Inclusion of geophysical and drillhole data will also be implemented to evaluate the structural geologic setting as it relates to traps and seals.

Methods and technical procedures

The methods and technical procedures for this activity are given in the following table.

Method	Technical procedure		
	Number	Title	Date
Organic-matter sampling and sample-preparation plan	TBD ^a	TBD	TBD
Conodont sampling plan	TBD	TBD	TBD
Analytical methods-thermal maturation	TBD	TBD	TBD

^aTBD = to be determined.

CONSULTATION DRAFT

8.3.1.9.2.1.5 Activity: Mineral and energy assessment of the site, comparison to known mineralized areas, and the potential for undiscovered resources and future exploration

Objectives

The objective of this activity is to integrate the data and information collected from Activities 8.3.1.9.2.1.1 (geochemical assessment), 8.3.1.9.2.1.2 (geophysical/geologic assessment), 8.3.1.9.2.1.3 (geothermal energy assessment), and 8.3.1.9.2.1.4 (hydrocarbon assessment). Integration of these activities and the data acquired from them will allow:

1. The identification of mineral resources with current markets, as well as the calculation of gross and net values for identified resources or reserves.
2. The physical description of mineral resources with potential future markets relative to "tonnage, or other amount, grade, and quality," as described in 10 CFR 60.21(c)(13).
3. The physical description of energy resources using appropriate parameters that describe the extent and magnitude of those resources.
4. The evaluation of the resource potential of any identified or undiscovered mineral and energy resources, based upon a "representative" area of "similar size" and a comparison to the Yucca Mountain site (10 CFR 60.122(c)(17)).
5. An estimation of the potential for undiscovered deposits of those resources described in 10 CFR 60.21(c)(13). This will be accomplished using site-specific data in conjunction with evaluation of models found in the literature of economic mineralization, hydrocarbon generation and entrapping processes, and extraction-conversion methods in geothermal energy utilization.

This activity provides data necessary for the probabilistic calculations for determining future inadvertent human interference or intrusion (Study 8.3.1.9.3.2).

Parameters

Existing site-specific data and data collected under Activities 8.3.1.9.2.1.1, 8.3.1.9.2.1.2, 8.3.1.9.2.1.3, and 8.3.1.9.2.1.4 will be used to calculate grades, tonnages, or other amounts. Information obtained from the literature will allow a comparison of analog areas and literature models with the site-specific data obtained for Yucca Mountain under the activities just listed.

Description

Information from Activities 8.3.1.9.2.1.1 and 8.3.1.9.2.1.2 and other site-specific data from the literature will be used to calculate gross and net values of commodities of current commercial value and commodities that

CONSULTATION DRAFT

may have future commercial value. These site-specific grades, tonnages, or amounts will be compared with the average abundances in crustal rock types to determine if the site has extractable commodities that may be of commercial value, of future commercial value, or anomalous concentrations of a commodity that would attract exploration.

Information from Activities 8.3.1.9.2.1.3 and 8.3.1.9.2.1.4 and other site-specific data from the literature will be used to describe energy resource potential. More detailed assessment of energy resources will be conducted if warranted by data from this activity.

This activity will compare analog environments of known mineralization with the site. Information on selected analogs will be obtained from the existing literature and Activities 8.3.1.9.2.1.1, 8.3.1.9.2.1.2, 8.3.1.9.2.1.3, and 8.3.1.9.2.1.4. Ideally, the selected analogs will consist of similar rock types and will have originated under similar geologic conditions. Other analogs will be chosen to contrast the site with known areas of mineralization found within calderas (e.g., Jefferson Caldera) and in the margins of calderas (e.g., Round Mountain and Goldfield). The large body of available literature, including petrologic, petrogenetic, structural, geophysical, mineralogic, and analytical data of the rocks located at the site, will be incorporated into this activity. This information will be used to evaluate the potential for mineral exploration at the site and the potential for undiscovered deposits using reasonable inference based on geologic and geophysical evidence. This activity will allow a final qualitative assessment of the mineral resources at the site in terms of their present value, potential future value, and the site's attractiveness for future exploration.

For energy resources, a final qualitative assessment of the resources at the site will be based on the presence or absence of favorable circumstances, and other direct or indirect evidence.

This activity will also provide synthesized data and evaluations of those data relative to assessing any initiating events under human interference that may be potentially unworthy of further consideration (Activity 8.3.1.9.3.2.2). These data and data evaluations are anticipated to facilitate the requisite probabilistic calculations (Study 8.3.1.9.3.2), but in some instances a less rigorous treatment may be used to dismiss events if they are considered sufficiently noncredible.

Methods and technical procedures

There are no procedures for Activity 8.3.1.9.1.5. Existing data and data obtained from Activity 8.3.1.9.2.1.1 will be used in this activity.

8.3.1.9.2.2 Study: Water resource assessment of Yucca Mountain, Nevada

This study consists of a single activity that will use available data to estimate the present and future value of the ground-water resource at and in the vicinity of the Yucca Mountain site.

CONSULTATION DRAFT

8.3.1.9.2.2.1 Activity: Projected trends in local and regional ground-water development, and estimated withdrawal rates in southern Nevada, proximal to Yucca Mountain

Objectives

The objective of this activity is to (1) assess the current and projected supply and demand situation for ground water in the geohydrologic study area, and (2) estimate the value of the ground-water resource.

Parameters

Three sets of parameters are required for this activity:

1. The determinants of supply, which include quantities available from alternative sources; cost of water by alternative source; the physical and chemical characteristics of the ground-water system (e.g., recharge, aquifer depth, volume, and salinity); and institutional factors relating to water laws and rights (e.g., preferred beneficial uses).
2. The determinants of demand, which include population data (i.e., historical, current, and projected trends); economic conditions, including industry, employment, and income; trends in consumptive uses of water (i.e., domestic, commercial, industrial, and agricultural uses); climate; and price.
3. Empirical estimates of the value of water in various uses (i.e., domestic, commercial, industrial, and agricultural).

Description

Current and projected marginal supply curves for water will be estimated. The effects of various current and projected socioeconomic conditions on ground-water development, use, and allocation will be evaluated. Where sufficient price and quantity data are available, water-demand curves can be estimated, from which estimates can be made of the marginal value of the water. For a variety of reasons, market-established prices for water are not generally available. However, there are a number of alternative means of estimating the value of the ground-water resource even in the absence of markets. These include evidence of prices paid for water by a given sector as an indication of the user's willingness to pay (an example of this is the recent purchase of ground water by Nevada Power Company in the Moapa Valley area), shadow prices determined via linear programming, change in net income or value-added approaches, and alternative and opportunity cost.

This information will be used to estimate the current and future value of the ground-water resource in the geohydrologic study area and to project probable withdrawal rates and locations. Estimations will be limited to the reasonably foreseeable future (10 CFR 960.4-2-8-1).

Methods and technical procedures

Water supply information will be obtained from a variety of sources including the Nevada Department of Natural Resources and Conservation, the Water Resources Division; the USGS; the Bureau of Reclamation; the Las Vegas Valley Water District; and Activity 8.3.1.16.2.1.2 (location of primary water supply). Water use data will be obtained from the same sources.

Socioeconomic data (e.g., population, industry, and income) needed for the demand assessment will be acquired from a variety of sources, including the State of Nevada Employment Security Department, the U.S. Department of Commerce, the Bureau of Census, the Bureau of Economic Analysis, and future NNWSI Project socioeconomic county profiles.

The determination of water valuation methods will be made subsequent to a literature review of existing methodologies and their applicability to the relevant water uses in the study area.

8.3.1.9.2.3 Application of results

The information obtained from the activities of this investigation will be used in conjunction with data presented in the Yucca Mountain environmental assessment (DOE, 1986b) and Sections 1.7 and 3.8 of the SCP to determine those resources having any potential for occurrence at Yucca Mountain. These resources, and the applicable extraction and exploitation techniques, will be examined to determine the effects on the hydrologic, geochemical, and rock characteristics that could potentially result from future exploitation (Section 8.3.1.9.3).

The data from this investigation will also be considered in determining the likelihood for future exploratory drilling within the boundaries of the perimeter drift. Knowledge of the types of specific resources that could exist, based on geologic evidence and the geologic environment, can provide useful information regarding exploration techniques (e.g., random drilling and drill-bit diameter) that can be used as a logical basis for forming the assumptions for the most probable release scenarios. Thus, information obtained from these activities will be used as input parameters for Investigation 8.3.1.9.3.

8.3.1.9.2.4 Schedule and milestones

This investigation contains two studies: 8.3.1.9.2.1 (natural resource assessment of Yucca Mountain, Nye County, Nevada) and 8.3.1.9.2.2 (water resource assessment of Yucca Mountain, Nevada). In the figure that follows, the schedule information for these studies is presented in the form of timelines. The timelines extend from implementation of the approved study plans to the issuance of the final products associated with the studies. Summary schedule and milestone information for this investigation can be found in Section 8.5.1.1.

CONSULTATION DRAFT

Both studies in this investigation are planned to begin within the first year of site characterization. This investigation is planned to provide the information required to evaluate the present and future value of energy, mineral, hydrocarbon, and ground-water resources. Results will provide the input required to determine the likelihood of future inadvertent human interference with the site.

The studies in this investigation are constrained by the availability of data from other sources. The final products associated with these studies require data from Study 8.3.1.16.2 (location of adequate water supplies) and energy, mineral, land, and ground-water resource information from Federal, State, and local agencies.

The study numbers and titles corresponding to the timelines are shown on the left of the following figure. The points shown on the timelines represent major events or important milestones associated with the study. Solid lines represent study durations, and dashed lines show interfaces. The data input and output at the interfaces are shown by circles.

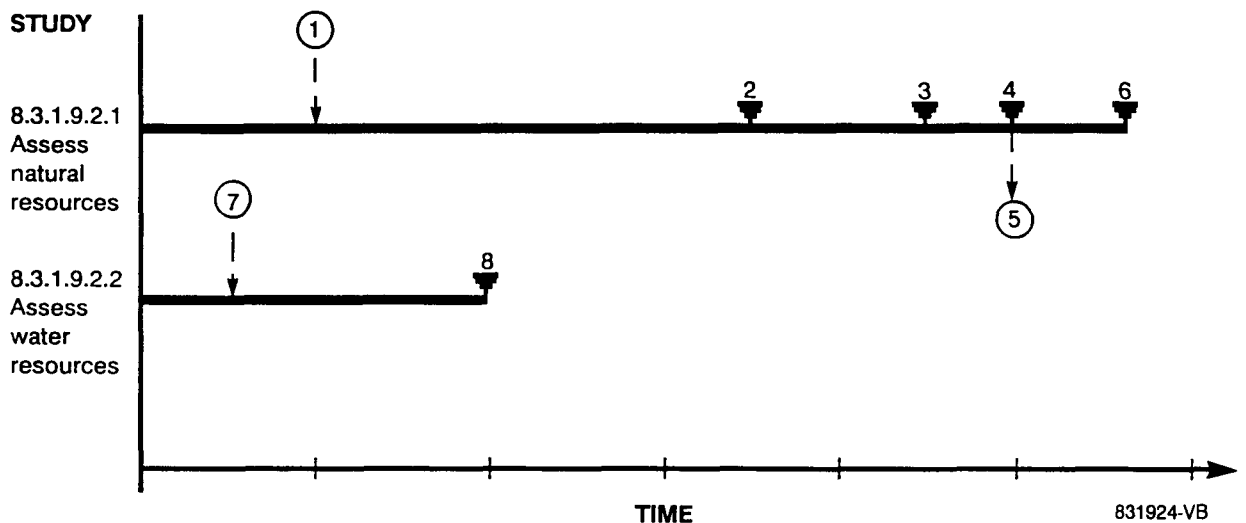

The points on the timeline and the data input and output at the interfaces are described in the following table:

<u>Point number</u>	<u>Description</u>
1	Data input from Study 8.3.1.8.5.2 (evaluation of heat flow at Yucca Mountain).

CONSULTATION DRAFT

<u>Point number</u>	<u>Description</u>
2	Milestones R589 and R590. Issue reports on assessment of mineral resources and geothermal energy potential.
3	Milestone R591. Issue report on assessment of hydrocarbon resources.
4	Milestones R595 and R596. Issue reports on potential for mineralization and potential for undiscovered resources.
5	Data results from study output to Investigation 8.3.1.9.3 (studies to provide the information required on potential effects of exploiting natural resources on hydrologic, geochemical, and rock characteristics).
6	Milestone T082. Issue final report on the evaluation of natural resources at Yucca Mountain and vicinity.
7	Input from Study 8.3.1.16.2 (adequate water supplies).
8	Issue report on water resource assessment at Yucca Mountain.

8.3.1.9.3 Investigation: Studies to provide the information required on potential effects of exploiting natural resources on hydrologic, geochemical, and rock characteristics

Technical basis for obtaining the information

Links to the technical data chapters and applicable support documents

A preliminary evaluation of the resource potential of the Yucca Mountain site is presented in the Yucca Mountain environmental assessment (DOE, 1986b) and in Sections 1.7 and 3.8 of the SCP. Studies will be performed to determine the extent to which the actual or inferred presence of resources at the site might influence the exploration activities of future generations. Additional studies will establish the potential effects of resource exploitation and extraction on the hydrologic, geochemical, and rock characteristics at and in the vicinity of Yucca Mountain.

Ground water currently is the only resource being considered. If other economically attractive resources or reserves are identified during the natural resource assessment that is being conducted in support of Investigation 8.3.1.9.2, the potential effects of their exploitation will also be evaluated. These data will be assessed by a panel of experts to determine the probability that human intrusion into, or interference with, a MGDS could result from the actual or inferred presence of natural resources.

CONSULTATION DRAFT

Parameters

The only parameters that have been identified to date are (1) projected rates and the probable locations of future ground-water withdrawals within the geohydrologic study area, (2) the results of the resource assessment (Study 8.3.1.9.2.1), and (3) the probabilities for inadvertent human interference and intrusions.

Additional parameters that will be required if other resources are identified (Investigation 8.3.1.9.2) include the specific types, locations, distributions, and quantities (i.e., grades, tonnages, and volumes) of the materials identified. Necessary information regarding the applicable extraction and exploitation methods will be taken from the literature. Site characterization activities and the existing data base will provide the baseline information relative to the hydrologic, geochemical, and rock characteristics at the site.

Purpose and objectives of the investigation

The purpose of this investigation is to obtain the information that will be used to satisfy the parameter requests made in Issue 1.1 (total system performance). Two types of data are requested in this performance issue: (1) information on the resources presently at the site that would influence the likelihood of exploratory drilling within the controlled area, and (2) the potential effects of resource extraction on the hydrologic, geochemical, and rock characteristics at the site. The first objective of this investigation is to evaluate the data relative to the resource potential of the site, resource extraction, and marker system survivability necessary to determine the probability range for exploratory drilling. The second objective is to assess the potential effects of resource extraction for all commodities known to be present or inferred to be present at the site. Thus, this investigation will compile all the site data generated by the human interference program and pass the required parameters to Issue 1.1.

Technical rationale for the investigation

To determine the effects of resource exploitation on the hydrologic, geochemical, and rock characteristics at the Yucca Mountain site, it will be necessary to estimate the quantities as well as the locations and distributions of those resources identified in the assessment. These resource parameters, together with their applicable extraction and exploitation methods, will be evaluated to determine qualitatively the effects of exploitation. For instances in which it is possible to model the effects using computer codes, such as with ground-water withdrawals, potential effects will be quantified. The data that will be collected by Studies 8.3.1.9.1.1, 8.3.1.9.2.1, and 8.3.1.9.2.2 will be evaluated to determine the likelihood for human interference and intrusion. Figure 8.3.1.9-4 shows the data flow for this investigation.

Two studies will be undertaken in fulfillment of this investigation. Study 8.3.1.9.3.1 will address factors that directly influence the amount of radionuclide releases that could result from inadvertent human interference and intrusion at the site. The studies to be undertaken to evaluate the potential effects of resource exploitation will be defined in detail when the

INTERMEDIATE PERFORMANCE MEASURE

PERFORMANCE PARAMETER

CHARACTERIZATION PARAMETER

DATA REQUIRED

KEY DATA COLLECTION ACTIVITIES

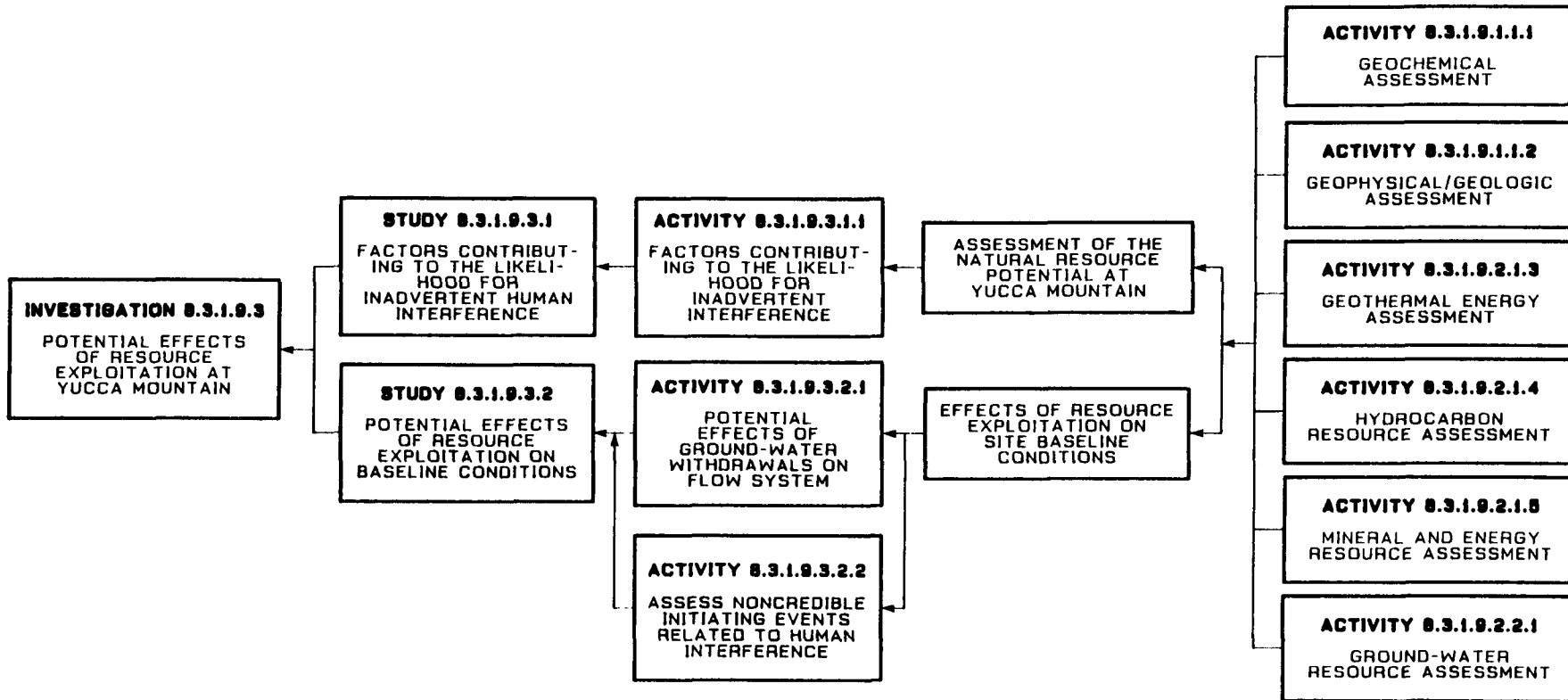

8.3.1.9-42

CONSULTATION DRAFT

Figure 8.3.1.9-4. Logic diagram for Investigation 8.3.1.9.3.

CONSULTATION DRAFT

resource assessment (Study 8.3.1.9.2.1) is completed. On the basis of the data available to date, ground water is the only resource known to be present. Specific plans for evaluating the effects of ground-water withdrawal are presented in the following sections. The second study (8.3.1.9.3.2) will present supporting discussions necessary to demonstrate that certain initiating events identified in the human interference program are not credible and therefore not significant.

8.3.1.9.3.1 Study: Evaluation of data needed to support an assessment of the likelihood of future inadvertent human intrusion at Yucca Mountain as a result of exploration and/or extraction of natural resources

In this study, data will be compiled and analyzed for assessing the likelihood of inadvertent human interference in the vicinity of Yucca Mountain. The initiating events for which data will be compiled include exploratory drilling for natural resources and ground-water withdrawal.

8.3.1.9.3.1.1 Activity: Compilation of data to support the assessment calculation of the potential for inadvertent human intrusion at Yucca Mountain

Objectives

The objectives of this activity are to

1. Determine the maximum drilling density and frequency (drillholes per square kilometer per 10,000 yr) that can be reasonably assumed for a repository at Yucca Mountain.
2. Determine the extent to which future ground-water withdrawals will modify the expected ground-water flow paths.

Parameters

The parameters that will be obtained or evaluated by this activity include:

1. Expected drilling density.
2. Distribution and expected depth of drillholes.
3. Expected distribution of drillhole diameters.
4. The probabilities that human interference or intrusion will occur as a result of exploratory drilling or exploitation.

The natural resource assessment parameters for this activity will be input from Study 8.3.1.9.2.1 (assessment of the natural resource potential at

CONSULTATION DRAFT

Yucca Mountain) and Study 8.3.1.9.3.1 (effects of natural resource exploitation at Yucca Mountain). These data will be used to aid in estimating the likelihood of the initiating events (Table 8.3.1.9-1) for human intrusion and interference at Yucca Mountain during the postclosure period.

Description

This activity will involve compiling data to determine the anticipated maximum drillhole density, borehole diameter, and depths of the drillholes over the next 10,000 yr in the vicinity of Yucca Mountain. The activity will also assess potential effects of future ground-water withdrawal on expected ground-water flow paths. The results of the natural resource assessment studies (8.3.1.9.2.1, 8.3.1.9.2.2, and 8.3.1.9.3.1) will be used in this activity. In addition, information on state-of-the-art exploration and drilling techniques, as well as information on expected future exploration and drilling equipment trends, will be analyzed in this activity.

Methods and technical procedures

The methods and technical procedures for this activity are to be determined.

8.3.1.9.3.2 Study: An evaluation of the potential effects of exploration for, or extraction of, natural resources on the hydrologic characteristics at Yucca Mountain

This study will assess in qualitative or quantitative terms, the effects of exploiting natural resources known or believed to be present at Yucca Mountain. Consideration of the effects of resource exploitation or extraction are limited to changes in the hydrologic, geochemical, and rock characteristics.

8.3.1.9.3.2.1 Activity: An analysis of the potential effects of future ground-water withdrawals on the hydrologic system in the vicinity of Yucca Mountain, Nevada

Objectives

The objective of this activity is to determine the potential effects of future ground-water withdrawals on the hydrologic system at Yucca Mountain. Effects of the withdrawals will be defined qualitatively and quantitatively.

Parameters

The parameters required for this study are the following:

1. The time-phased estimates of ground-water withdrawals as projected from the activity described in Investigation 8.3.1.9.2.

CONSULTATION DRAFT

2. The probable locations of the wells from which projected withdrawals would be made. Locations need only be accurate to within a single hydrographic area (Section 3.8.1). This parameter will also be passed from Investigation 8.3.1.9.2.
3. The appropriate hydrologic parameters (aquifer characteristics) will be obtained from Investigation 8.3.1.2.3.

Description

Various computer models, such as FEMOD (Czarnecki, 1985) will be used to analyze the potential effects of ground-water withdrawal on the local hydrologic system. The input parameters supplied from Investigation 8.3.1.9.2, when used in the computer model, will allow simulation of the changes in the geohydrologic system that might occur as a result of withdrawals through time. The results from the model will provide qualitative and quantitative information on the potential effects of ground-water withdrawals within the geohydrologic system.

Methods and technical procedures

The methods and technical procedures for this activity are to be determined.

- 8.3.1.9.3.2.2 Activity: Assessment of initiating events related to human interference that are considered not to be sufficiently credible or significant to warrant further investigation

Objectives

The objective of this activity is to demonstrate that those initiating events which have been identified (Table 8.3.1.9-1) for the human interference issue are not considered sufficiently credible or significant to necessitate additional investigation. This will be documented in a topical report.

Parameters

The parameters that will be obtained or calculated by this activity are grouped by initiating events and include the following:

1. Large-scale surface-water impoundment constructed near the controlled area.
 - a. Area, depth, and volume of surface impoundment.
 - b. Seepage and percolation rates, and transmissivities of near surface and subsurface materials.
2. Extensive irrigation is conducted near the controlled area.

CONSULTATION DRAFT

- a. Area of irrigation.
- b. Quantity of water available for irrigation.
- c. Types of crops cultivated.
- d. Infiltration and percolation rates.
- e. Quantity of water applied for irrigation.

All initiating events will require information on the presence and readability of the markers over 10,000 yr.

Description

The results of the natural resource assessment activities along with data from the activities in Section 8.3.1.2 (geohydrology) will provide input to this activity. These data will be used to assess the credibility and significance of the initiating events of potential human interference activities at Yucca Mountain. A special panel of experts from the disciplines of natural resources exploration, geosciences, economics, social sciences, and statistics will be convened to make a qualitative assessment of the non-credible or insignificant initiating events by using their experience and the parameters listed previously. The panel's professional judgment along with previously noted data will be used to prepare topical reports on those non-credible and insignificant initiating events.

Methods and technical procedures

The methods and technical procedures for this activity are to be determined.

8.3.1.9.3.3 Application of results

The information obtained from the activities supporting Investigations 8.3.1.9.1 and 8.3.1.9.2 will be assessed by a panel of experts (Study 8.3.1.9.3.1). The professional judgment of the panel members will be used to estimate the bounds on the probability of inadvertent human interference and intrusion resulting from potential exploratory activities (Louden, 1979). The information obtained in Investigation 8.3.1.9.2 will be used in Issue 1.9 (higher level findings--postclosure) to demonstrate that human interference and intrusion will not likely arise due to exploration and extraction of natural resources. The information obtained from Study 8.3.1.9.3.2 will be used in Issue 1.1 (total system performance) to develop the most-probable release scenarios. These data will be provided as input parameters to Issues 1.1 and 1.8 (NRC siting criteria) for use in calculating total system releases and in evaluating the potentially adverse conditions.

8.3.1.9.3.4 Schedule and milestones

This investigation contains two studies: 8.3.1.9.3.1 (factors contributing to the likelihood for inadvertent human interference) and 8.3.1.9.3.2 (potential effects of resource exploitation on site conditions). In the figure that follows, the schedule information for these studies is presented

CONSULTATION DRAFT

in the form of timelines. The timelines extend from implementation of the approved study plans to the issuance of the final products associated with the studies. Summary schedule and milestone information for this investigation can be found in Section 8.5.1.1.

Both studies in this investigation are out-year studies, and their completion is constrained by the availability of data from other investigations (See Figure 8.3.1.9-2). Results from these other studies will provide information required to evaluate the probability of future resource exploration and exploitation, and the potential effects of exploiting natural resources on hydrologic, geochemical, and rock characteristics.

The study numbers and titles corresponding to the timelines are shown on the left of the following figure. The points shown on the timelines represent major events or important milestones associated with the studies. Solid lines represent study durations, and dashed lines show interfaces. The data input and output at the interfaces are shown by circles.

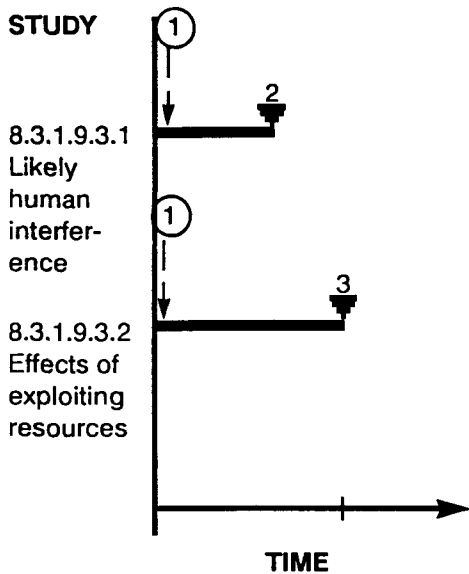

The points on the timeline and the data input and output at the interfaces are described in the following table:

<u>Point number</u>	<u>Description</u>
1	Data input from Investigation 8.3.1.9.2.
2	Milestone R676. Issue report on factors contributing to the likelihood of human interference and intrusion events at Yucca Mountain.

CONSULTATION DRAFT

Point
number

Description

3

Milestones Z473 and Z474. Issue reports on potential effects of exploiting ground water and assessment of unlikely initiating events of human interference.

Nuclear Waste Policy Act
(Section 113)

Section 8.3.1.10

Consultation Draft

**POPULATION DENSITY AND
DISTRIBUTION**



Site Characterization Plan

***Yucca Mountain Site, Nevada Research
and Development Area, Nevada***

Volume V

January 1988

U.S. Department of Energy
Office of Civilian Radioactive Waste Management
Washington, DC 20585

CONSULATIVE DRAFT

8.3.1.10 Overview of population density and distribution program: Description of population density and distribution required by the performance and design issues

This section presents references and information to support resolution of performance and design issues related to preclosure radiological safety. These requirements are derived from 10 CFR Part 20, 10 CFR Part 60, 40 CFR Part 191 and DOE orders. The detailed link to these regulations is presented in the performance and design issues that require data from the population density and distribution program.

Collection of population density and distribution data is not considered a site characterization activity as defined in the Nuclear Waste Policy Act (NWPA, 1983). Therefore, the format and details for data collection will not be presented in this document. However, population density and distribution remains an important component of the program of preclosure radiological safety for members of the general public, whether through normal operations or as a result of accident conditions (Issues 2.1 and 2.3). The data base established during this program will contribute to Issue 2.5, which addresses higher level findings on the qualifying and disqualifying conditions of the DOE siting guideline on population density and distribution (10 CFR 960.5-2-1).

The distribution of future populations in highly populated areas and in unrestricted areas is currently recognized as a significant factor in defining preclosure radiological safety programs. Preparation of a radiological monitoring plan will help to establish the data base required for resolution of performance and design issues related to radiological safety. This plan, in part, will be the mechanism for implementing the studies necessary for calculating radionuclide doses to members of the general public at varying distances from the potential repository location at Yucca Mountain. The details of the methodology to be used in analyzing the population related information will be discussed in the Radiological Monitoring Plan. The methods and procedures for collection of population data will be part of the NNWSI Project socioeconomic planning process and environmental program planning effort.

Nuclear Waste Policy Act
(Section 113)

Section 8.3.1.11

Consultation Draft

LAND OWNERSHIP AND
MINERAL RIGHTS

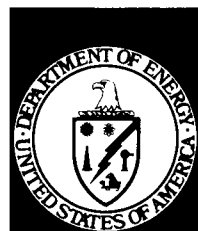

Site Characterization Plan

***Yucca Mountain Site, Nevada Research
and Development Area, Nevada***

Volume V

January 1988

U.S. Department of Energy
Office of Civilian Radioactive Waste Management
Washington, DC 20585

8.3.1.11 Overview of land ownership and mineral rights program: Description of status and plans for land ownership and mineral rights required by the performance and design issues

The land ownership and mineral rights program derives from the requirements of 10 CFR Part 960 and 10 CFR Part 60. The provisions of 10 CFR 60.121 require that

Both the geologic repository operations area and the controlled area shall be located in and on lands that are either acquired lands under the jurisdiction and control of DOE, or lands permanently withdrawn and reserved for its use.

This provision further requires that (1) such lands shall be held free and clear of all encumbrances, (2) the DOE shall exercise any jurisdiction and control over surface and subsurface estates necessary to prevent adverse human actions that could significantly reduce the repository's ability to achieve isolation, and (3) the DOE shall also have obtained water rights as may be needed to satisfy the requirements of the repository operations area.

The plans and procedures for acquiring land ownership and mineral rights are not considered site characterization activities as defined by the Nuclear Waste Policy Act (NWPA). Therefore, the standard format and level of detail as is presented for other programs will not be provided in this section. However, the regulatory requirements just listed are an essential component of the repository program in that they provide for a controlled site, which in part addresses preclosure radiological safety aspects of the program. Information about postclosure site ownership and control is presented in Sections 8.3.5.18 (postclosure higher level findings) and 8.3.1.9 (human interference). The performance and design issues concerning radiological dose calculations to the public and workers (Issues 2.1, 2.2, 2.3, and 2.7, Sections 8.3.5.3, 8.3.5.4, 8.3.5.5, and 8.3.2.3, respectively) can be addressed with the knowledge that actions will be taken to withdraw and control the appropriate portion of land in accordance with applicable regulations. In addition, compliance with these requirements will support Issue 2.5 (Section 8.3.5.6), which addresses higher level findings on the qualifying and disqualifying conditions of the site ownership and control guidelines in 10 CFR Part 960. Another aspect of the land ownership program is the process by which the land is acquired and controlled, including rights to subsurface resources. This process is described in the following paragraphs.

The parameters of the controlled area are defined in 40 CFR Part 191 and are based on information about the subsurface. After tentatively identifying the outline of the proposed repository site, the information-gathering elements of the land ownership program will occur in three basic steps. The first step is to define the boundaries of the parcel for which the DOE must obtain control and seek withdrawal. Inherent in this step is applying the information gained during site characterization that would influence the boundaries at the controlled area and accessible environment.

CONSULTATION DRAFT

The second step is to ascertain the status of any preexisting outside rights with respect to the land at the site. Prior investigations have identified no such rights (e.g., mineral, grazing, or water rights) at or in the immediate vicinity of Yucca Mountain. However, monitoring of these situations during site characterization will be conducted by the DOE.

The third step involves the actual process by which information will be obtained for purposes of supporting a withdrawal application as set forth in FLPMA and implementing Bureau of Land Management (BLM) regulations.

As established in the environmental assessment for the Yucca Mountain site (DOE, 1986b), the land area of interest to the DOE for the repository operations area and controlled area is entirely on Federal lands controlled by three Federal agencies. These lands include the Nellis Air Force Range (NAFR) controlled by the U.S. Department of the Air Force (DAF), the Nevada Test Site (NTS) controlled by the DOE, and public lands controlled by the U.S. Department of the Interior (DOI), BLM. The Military Lands Withdrawal Act of 1986 (Public Law 99-606), recently enacted by Congress, withdrew the 2.9 million acre NAFR for defense-related use by the DAF. Management of these lands remains the responsibility of the BLM.

The land area of interest to DOE currently under BLM control is in the public domain and has not been segregated from the operation of the public land laws. There exists, therefore, a possibility that control of surface and subsurface rights on the public lands could change as a result of rights granted under FLPMA or applicable mining laws.

The ownership and control status of the land area of interest is important to the DOE for a variety of reasons. These include the length of time required to conduct site characterization activities, the land management plans and agreements, and the public domain status of the BLM controlled lands. The DOE will monitor not only actions taken by the BLM or DAF with regard to the land areas of interest to the DOE but also the current or proposed laws and regulations that may impact land ownership and control, or the rights to access such lands.

If the Yucca Mountain site is recommended and approved for development as a repository following site characterization, it will be necessary, pursuant to 10 CFR 60.121, for the DOE to withdraw the land that would comprise the repository operations area and controlled area and reserve this land for its use. Such a withdrawal action, under current law, must be made pursuant to applicable implementing regulations. To initiate a withdrawal action, FLPMA and the implementing regulations define the data and information required to be provided at the time of application to Congress to support the review of the application. Much of the required data and information will be collected as part of the site characterization activities or other programmatic activities planned by the DOE. The programmatic activities include the repository land withdrawal and control process and the environmental program planning effort for the Yucca Mountain site. To ensure that the data and information relevant and necessary to support a withdrawal action are acquired and documented properly, site characterization activities must be reviewed and withdrawal information and documentation requirements conducted in parallel with the site characterization program. A similar requirement to recognize and address withdrawal requirements also exists for

CONSULTATION DRAFT

additional DOE activities directed at assessing the suitability of the Yucca Mountain site under 10 CFR Part 960 and preparing input to the environmental impact statement required by the NWPA (1983) and the National Environmental Policy Act (NEPA, 1969).

Nuclear Waste Policy Act
(Section 113)

Section 8.3.1.12

Consultation Draft

METEOROLOGY



Site Characterization Plan

Yucca Mountain Site, Nevada Research and Development Area, Nevada

Volume V

January 1988

U.S. Department of Energy
Office of Civilian Radioactive Waste Management
Washington, DC 20585

CONSULTATION DRAFT

8.3.1.12 Overview of the meteorology program: Description of meteorological conditions required by the performance and design issues

Summary of performance and design requirements for meteorological information

The purpose of the meteorological program is to provide data required for resolution of performance and design issues. The types of data requested fall into three categories: (1) data needed in calculating radiological doses resulting from airborne releases from the repository during the pre-closure operational period; (2) information required for design of surface facilities; and (3) hydrometeorological measurements for hydrologic and climatic studies. Table 8.3.1.12-1 shows the link between the design and performance parameters (information needed) and the meteorology program parameters that satisfy those needs, respectively.

Approach to satisfy performance and design requirements

The purpose of the meteorology program is to establish (1) regional meteorological conditions (Investigation 8.3.1.12.1), (2) atmospheric and meteorological phenomena at potential locations of surface facilities (Investigation 8.3.1.12.2), (3) locations of population centers relative to wind patterns in the general region of the site (Investigation 8.3.1.12.3), and (4) potential extreme weather phenomena and their recurrence intervals (Investigation 8.3.1.12.4).

The investigations were created so that an understanding of the meteorology of the area, including both average and extreme climatic phenomena, would be gained. Such an understanding will require looking at data from sites throughout the region and relating and comparing these data to site-specific conditions. Parameters that are important in determining the dispersion characteristics and general regional meteorology and, hence, are important to the performance and design issues, are as follows:

1. Wind speed.
2. Wind direction.
3. Ambient temperature.
4. Atmospheric moisture.
5. Precipitation type, amount, frequency of occurrence, and intensity.
6. Atmospheric stability.
7. Mixing layer depth.

These data will provide input to the performance and design issues that assess the preclosure radiological safety aspects of the mined geologic disposal system under normal and accident conditions. These issues are as follows:

<u>Issue</u>	<u>Short title</u>	<u>SCP section</u>
2.1	Public radiological exposures-- normal conditions	8.3.5.3
2.2	Worker radiological safety-- normal conditions	8.3.5.4

Table 8.3 1.12 1. Performance allocation table for meteorology program

Issue	SCP section	Performance or design parameter	Characterization parameter	Testing basis			SCP study (or activity) ^a
				Current estimate	Current confidence	Needed confidence	
2 1, 2 2, 2 3, 4 2, and 4 4	8 3 5 3, 8 3 5 4, 8 3 5 5, 8 3 2 3, 8 3 2 4, and 8 3 2 5	X/Q	Wind speed	Figures 5-3 to 5-7	Low	High	8 3 1 12 1 1- Regional meteorological conditions 8 3 1 12 2 1 1- Site meteorological monitoring program
			Wind direction	Tables 5-6 and 5-7	Low	High	
			Temperature	Figures 5-3 to 5-7	Low	High	
			Mixing layer depth	Tables 5-6 and 5-7	Low	High	
			Atmospheric stability	Tables 5 2 and 5-3	Low	High	
			Atmospheric moisture	Quiring (1968)	Low	High	
			Precipitation (type, amount, intensity)	Table 5-11	Low	High	
2 2	8 3 5 4	Radon emanation rate from tuff	Temperature	Tables 5-2 and 5-3	Low	High	8 3 1 12 2 1 2 -Data summary for input to dose assessments
			Barometric pressure	Table 5-2	Low	High	
2 3 and 4 4	8 3 5 5 and 8 3 2 5	Accident initiating events	Extreme winds and frequency of occurrence	Tables 5 2 and 5 8	Medium	High	8 3 1 12 4 1--Potential extreme weather phenomena and their reoccurrence
			Lightning strikes and frequency	Section 5 1 1 6	Medium	High	
			Precipitation extremes (snow, rain, ice, and amounts and frequency)	Tables 5 2, 5 4, and 5-10	Medium	High	
			Temperature extremes	Tables 5-2, 5-3, and 5-9	Medium	High	

^aStudies and activities listed apply to all parameters associated with the issue

CONSULTATION DRAFT

<u>Issue</u>	<u>Short title</u>	<u>SCP section</u>
2.3	Accidental radiological releases	8.3.5.5
2.5	Higher level findings--preclosure radiological safety	8.3.5.6
2.7	Repository design criteria for radiological safety	8.3.2.3

The investigation that deals with population centers relative to wind patterns (Investigation 8.3.1.12.3) will be a part of the radiological assessment because wind is the primary transport mechanism by which airborne radionuclides would reach these population centers. Finally, characterization of potential extreme weather phenomena (e.g., tornadoes, hurricanes, extreme wind speeds, temperature and humidity extremes, precipitation extremes, and obstructions to visibility) will provide input to design criteria issues relative to radiological safety. The extreme weather data will be evaluated in designing physical systems or components of the repository (e.g., wind or snow loading, heating and cooling systems, freeze protection) and must also be factored into the safety analysis in terms of the potential for extreme weather to initiate radiological accidents. Both repository operations and transportation of waste to the site will make use of the extreme weather data, and these data could be important in access route assessments.

Data collected as part of this program will also provide input to investigations associated with the geohydrology program and will be used, for example, in developing storm trajectories through the area. The relationship of the meteorology program to design issues, performance issues, and other programs is shown on the logic diagram for the meteorology program in Figure 8.3.1.12-1. This logic diagram also indicates how the investigations planned to provide the program data are linked to the individual studies and activities.

The NNWSI Project environmental assessment (EA) (DOE, 1986b) included meteorological data and analyses from existing meteorological monitoring networks in the vicinity of Yucca Mountain. These data and analyses proved useful for the purposes of the EA in that they provided enough information to support conclusions for the favorable and potentially adverse conditions of 10 CFR Part 960 and, more importantly, to support a preliminary finding on the qualifying condition. Additional data, both regional and site specific, are necessary to support the higher-level findings on the qualifying conditions required at the time of repository site selection (Section 8.3.5.6).

Interrelationships of meteorology investigations

The data and information developed through the meteorology program and associated investigations will have connections with the following issues, programs, investigations, and information needs:

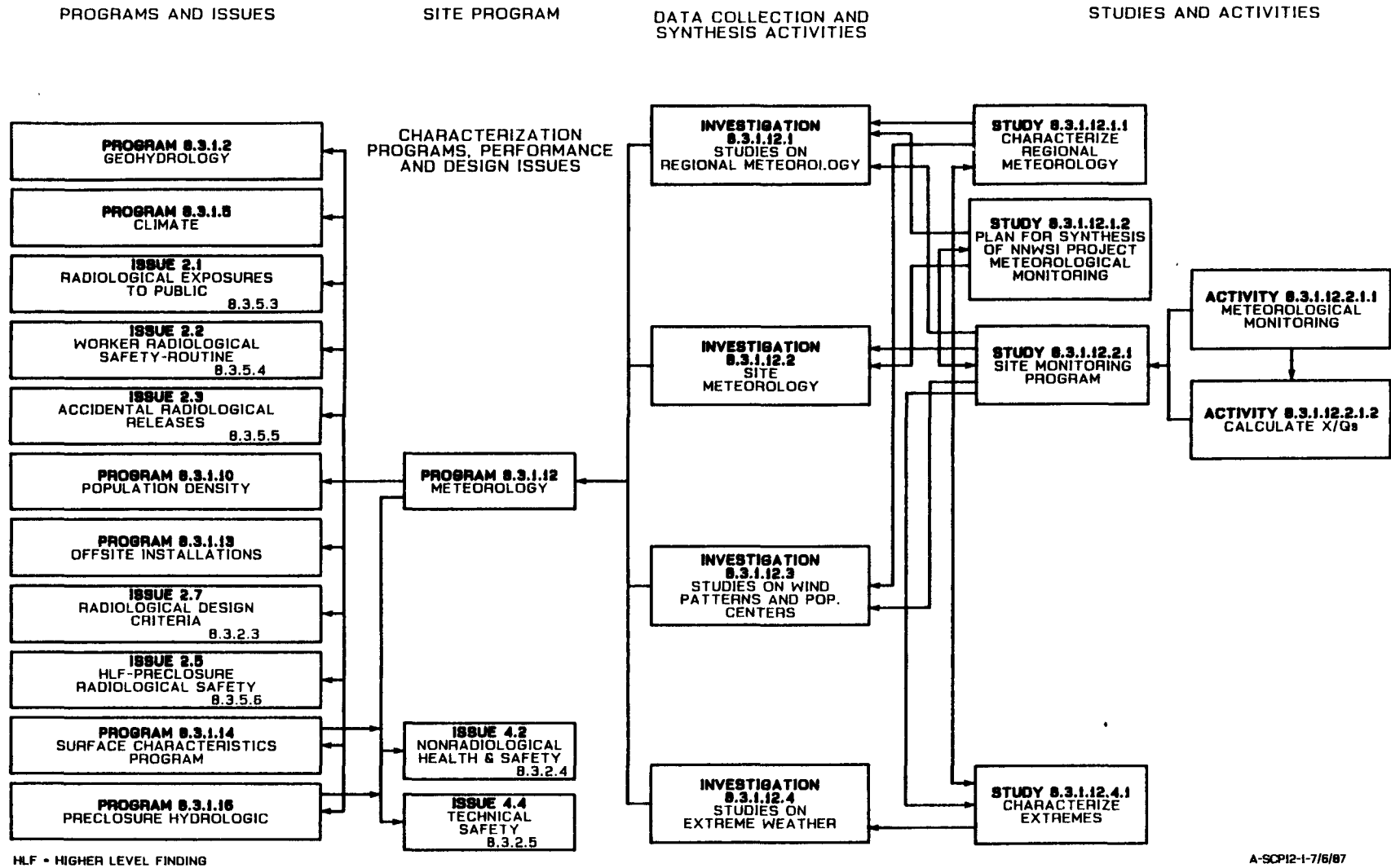

A-SCP12-1-7/6/87

Figure 8.3.1.12-1. General logic diagram for meteorology program.

CONSULTATION DRAFT

1. Issue 2.1: Preclosure doses to members of the public in highly populated areas and members of the public within any unrestricted area. Information Need 2.1.1--site and design information (Section 8.3.5.3.1)--is linked to the meteorology program.
2. Issue 2.2: Preclosure doses to workers. Information Need 2.2.1--natural radiation environment (Section 8.3.5.4.1)--is linked to the meteorology program.
3. Issue 2.3: Accident-related doses to workers and members of the public. This issue is resolved through Information Needs 2.3.3, worker exposures under accidental conditions (Section 8.3.5.5.3) and 2.3.4, public exposures under accidental conditions (Section 8.3.5.5.3).
4. Issue 2.5: Higher level findings relative to preclosure system and technical guidelines. Information Need 2.5.2--how the site meets and will continue to meet qualifying conditions of the technical guidelines (Section 8.3.5.6.2)--is related to the meteorology program.
5. Issue 2.7: Design characteristics of the repository in terms of design criteria and performance issues. Information Need 2.7.1--site information for design (Section 8.3.2.3.1)--is linked to the meteorology program.
6. Population density program. To be determined.
7. Program 8.3.1.13: Offsite installations. The investigation specifically linked with the meteorology program is offsite transportation (8.3.1.13.1).
8. Program 8.3.1.14: Surface characteristics. The applicable investigation under this program is meteorological conditions at surface facility locations.
9. Program 8.3.1.16: Preclosure hydrology. To be determined.
10. Program 8.3.1.2: Geohydrology. The investigations related to the meteorology program are Investigations 8.3.1.2.1 (description of the regional hydrologic system) and 8.3.1.2.2 (description of the unsaturated zone hydrologic system at the site).
11. Program 8.3.1.5: Climate. To be determined.

The schedule information provided for information needs in this section includes the sequencing, interrelationships, and relative durations of the activities in the information need. Specific durations and start/finish dates for the activities are being developed as part of ongoing planning efforts and will be provided in the SCP at the time of issuance and revised as appropriate in subsequent semiannual progress reports.

Summary of studies

The studies planned for the meteorology program fall into two general categories: (1) those studies that are concerned with only site-specific data and (2) those studies that are associated with regional meteorological conditions.

To gain an understanding of the regional meteorological conditions, existing data bases will be evaluated and their applicability to Yucca Mountain determined (Investigation 8.3.1.12.1). These data, in combination with data from the site monitoring program (see following discussion) will then be assimilated into a data set that represents the regional meteorological conditions. This investigation will also coordinate monitoring efforts needed for other issues or programs with the data being obtained through the meteorology program.

A site monitoring program consisting of five towers has been implemented at Yucca Mountain. The locations of these towers are shown in Figure 8.3.1.12-2. Although this network was initially established to support environmental permitting and licensing activities, the parameters being monitored will also be used as input in evaluating preclosure radiological impacts. The data being collected will serve as input to predictive models for dose calculations to ensure that radiological safety is not compromised as a result of the meteorological characteristics of the site.

The studies identified for characterizing wind patterns relative to population centers will consist of providing data on and analyses of wind parameters that will be used with the population density program identified in Section 8.3.1.10. These results will provide a clear understanding of wind transport patterns relative to population centers and will be used in determining if the patterns would preferentially carry radioactive material released to the air towards these centers.

The existing data bases and technical publications reviewed in characterizing the regional meteorology will also provide data on the extreme weather phenomena that may be experienced at the site. Because extreme weather can affect design and can cause accidents during repository operation and transportation of waste to the site, the occurrence of such phenomena and their recurrence interval must be determined (Investigation 8.3.1.12.4).

8.3.1.12.1 Investigation: Studies to provide data on regional meteorological conditions

Technical basis for obtaining the information

Link to the technical data chapters and applicable support documents

Technical data summaries of regional meteorological conditions are in Chapter 5 of the SCP and in the Yucca Mountain EA (DOE, 1986b). Specifically, Section 5.1 of the SCP includes descriptive text and tables on regional

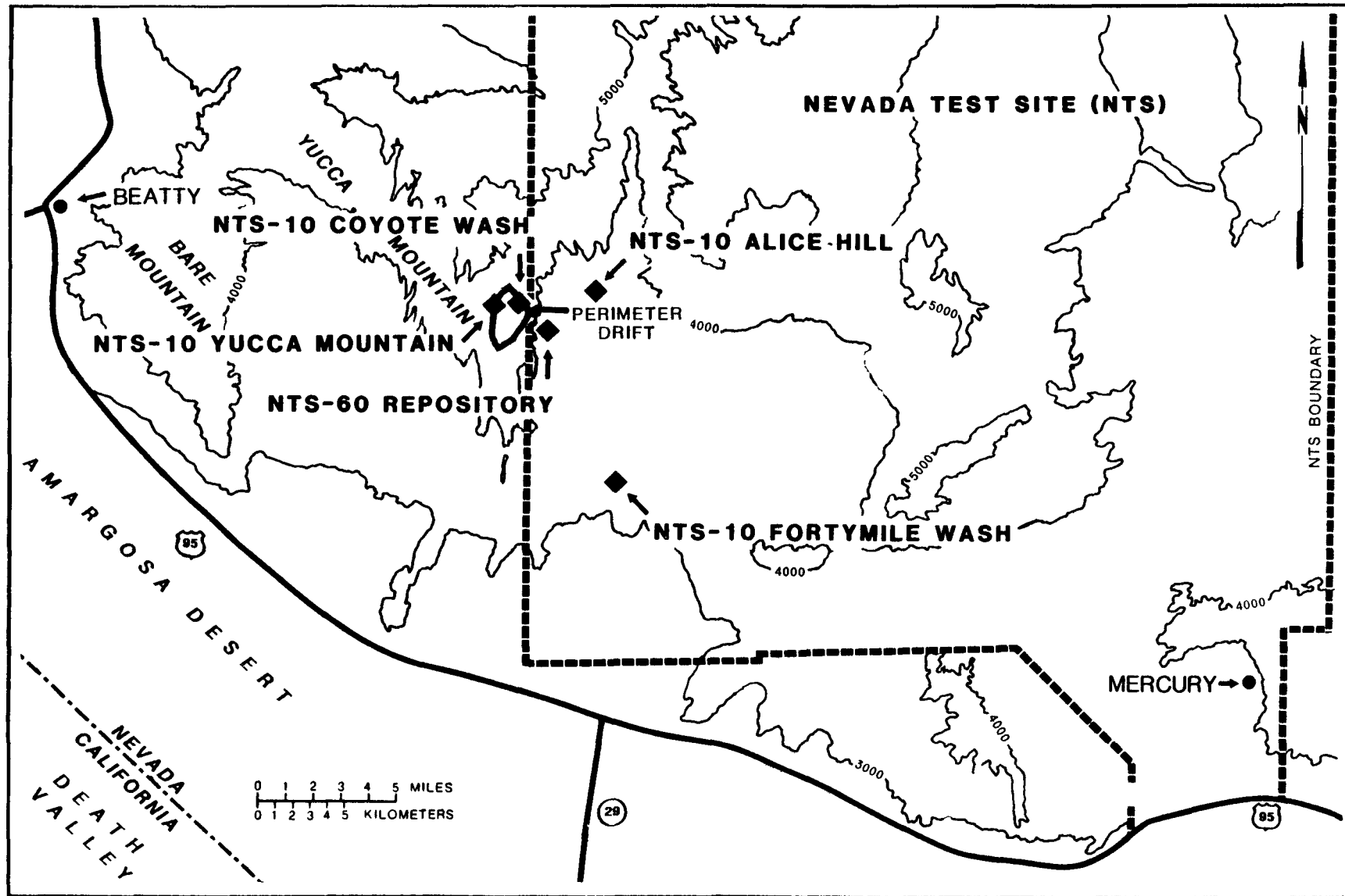

Figure 8.3.1.12-2. Meteorological monitoring sites operated as part of the Nevada Nuclear Waste Storage Investigations Project

CONSULTATION DRAFT

meteorology appropriate to the Yucca Mountain site. Section 3.4.3 of the EA includes material on regional meteorology and related environmental materials, such as air quality and noise.

Parameters

Existing data bases will be examined to characterize regional conditions in terms of the following meteorological parameters:

1. Wind speed.
2. Wind direction.
3. Ambient temperature.
4. Atmospheric moisture.
5. Precipitation type, amount, frequency of occurrence, and intensity.
6. Atmospheric stability.
7. Mixing layer depth.
8. Variability of parameters 1 through 5 at a given site and between sites.

Ideally, each data base examined would contain all of these parameters in a similar format (hourly averages). However, much of the existing data have been collected by private and governmental agencies for varying purposes and are not uniform in content, format, monitoring methodology, or quality. The data identified will, therefore, have to be carefully evaluated to determine their appropriateness to this study. Because some of the data will only be available as summaries of multiyear intervals (e.g., 5- or 10-yr climatological summaries), only general trends and averages for certain regions of the area around Yucca Mountain can be derived.

The data collected at the site (Section 8.3.1.12.2) will supplement the regional meteorology characterization and provide the relationship between the regional data and site-specific data. These data (specifically precipitation amounts used to track storm trajectories) will also serve as input to investigations associated with hydrology.

Purpose and objectives of the investigation

The purpose of this investigation is to provide data on the regional meteorological conditions in the general vicinity of Yucca Mountain, extending to Las Vegas, and to coordinate meteorology program monitoring efforts with other NNWSI Project meteorological monitoring. Some of the data can then be used in calculating radiation doses to the general public and at the nearest major population center that might be caused by the proposed repository under routine and accident scenarios.

CONSULTATION DRAFT

Technical rationale for the investigation

One of the major concerns in the siting of a geologic repository is to ensure that its design and performance do not result in radiological impacts, due to airborne releases, to workers and the general public that exceed established limits. Because this concern must be satisfied before the construction of the facility, predictive tools are used in estimating the impacts of postulated releases from the repository. These predictive tools are typically dispersion models, which require data on the transport mechanism (in this case the atmosphere). Impacts predicted to occur in the immediate vicinity of the release dictate the use of site-specific meteorological data. This need is covered in Section 8.3.1.12.2. However, the applicable regulations also require that impact determinations be made at distances up to 80 km (50 miles) from the source. Therefore, site-specific data must be used in conjunction with regional data. In addition, impacts at the nearest major population center must be evaluated. For Yucca Mountain, the nearest major center is Las Vegas, Nevada, which is 137 km (85 miles) by air southeast of the site.

Another aspect of the Yucca Mountain site that warrants examination of data from various locations is the terrain. Because the topography of the area is complex, data from any single location may reflect unique terrain influences. These site-specific data will be used in characterizing regional meteorology to show topographic influences on regional windflow and precipitation patterns.

The parameters listed above collectively determine how material emitted from the repository system will be transported downwind. In addition to providing a picture of the overall meteorology of the region, these parameters are required input to dispersion models that will be used in calculating impacts. Atmospheric moisture and precipitation, although not specifically needed in dispersion analyses, are other comparative tools used in determining overall weather patterns for the area. The seasonal variability of the data from any given site and the variability of parameters between sites will aid in constructing the regional meteorology. The operational life of the repository during which postulated releases could be occurring is several years. Therefore, regional data from stations that have operated for long periods of time will help establish a link between present-day meteorological conditions and long-term averages of meteorological parameters.

8.3.1.12.1.1 Study: Characterization of the regional meteorological conditions

Objectives

The objective of this study is to gather and analyze meteorological data from various locations to characterize the regional meteorology and assimilate that information into a regional summary report. This will be accomplished by determining if there are meteorological monitoring stations that have been operated in the general vicinity of the site and might be sources of information (in addition to those evaluated in Section 5.1). Comparisons between site and very-near-site data and data from these regional sources

CONSULTATION DRAFT

will give a more complete picture of the areal variability of conditions around the site than is presently available. This characterization will provide a regional overview of wind flow patterns and other meteorological parameters (related to atmospheric dispersion) associated with those patterns in and around Yucca Mountain.

Parameters

The parameters of interest, although many will not be available at all the monitoring locations identified, are

1. Wind speed.
2. Wind direction.
3. Ambient temperature.
4. Atmospheric moisture.
5. Precipitation type, amount, frequency of occurrence, and intensity.
6. Atmospheric stability (and method by which it was determined).
7. Mixing layer depth.

Description

This study will involve contacting potential sources of meteorological data and determining what data are available in the area of interest. Potential sources of data include the National Weather Service (NWS), State of Nevada agencies (the State), the Environmental Protection Agency (EPA), the Nevada Test Site (NTS), the Nellis Air Force Range (NAFR), Desert Research Institute (DRI), and any other entities, such as private industry, recommended by these initial contacts. The State and the EPA are likely to be useful sources of meteorological data because, in addition to data from stations they operate themselves, these agencies should be able to identify private industry concerns that are collecting or have collected meteorological data to fulfill regulatory requirements. The NTS will be a source of meteorological data because of its proximity to the Yucca Mountain site, and because it has operated a number of meteorological monitoring stations in support of DOE activities. The NWS is always a valuable resource in securing meteorological data, but the density of NWS stations in southwestern Nevada is somewhat low. Organizations like the DRI may be able to identify meteorological data collected in support of research efforts that are not driven by regulations. In addition, periodicals and journals will be reviewed for articles on the meteorology of the area. Obtaining the data on magnetic tape would facilitate analysis and summarization, but much of the data may not be available in that form.

Once the data have been obtained and reviewed in terms of the period of record, the parameters available, the sampling and averaging frequency and the quality, a report on the regional meteorology will be prepared. The report will include a discussion of general wind flow patterns and their seasonality, differences and similarities between sites, general trends of any given parameter, terrain influences, and the relationship between site-specific data (Section 8.3.1.12.2) and regional characteristics.

CONSULTATION DRAFT

Methods and technical procedures

The method and technical procedure for Study 8.3.1.12.1.1 is given in the following table:

Method	Number	Technical procedure	Date
		Title	
Data review and analysis	TBD ^a	Process for determining data acceptability	TBD

^aTBD = to be determined.

8.3.1.12.1.2 Study: Plan for synthesis of NNWSI Project meteorological monitoring

Objectives

The objective of this study is to develop a plan that provides for coordination of meteorological monitoring efforts proposed during site characterization by the various NNWSI Project participants.

Parameters

The parameters that will be incorporated into the coordination of NNWSI Project meteorological monitoring are:

1. Wind speed.
2. Wind direction.
3. Ambient temperature.
4. Atmospheric moisture.
5. Precipitation type, amount, frequency of occurrence, and intensity.
6. Atmospheric stability.
7. Mixing layer depth.
8. Barometric pressure.
9. Solar and terrestrial radiation.

Description

The plan that will be developed under this study will provide coordination between meteorological monitoring efforts initiated through Characterization Programs 8.3.1.12 (meteorology), 8.3.1.5 (climate), 8.3.1.2 (geohydrology), and 8.3.1.16 (preclosure hydrology). The plan will also provide for review of the various monitoring efforts proposed in terms of meteorological adequacy and consistency. The specific studies under these programs that are associated with meteorological monitoring are Study 8.3.1.2.1.1 (characterization of regional meteorology), Study 8.3.1.2.1.3

(characterization of regional ground-water flow), Study 8.3.1.2.2.1 (characterization of unsaturated zone infiltration), Study 8.3.1.5.1.1 (characterization of modern regional climate), and Study 8.3.1.12.2.1 (site meteorological monitoring). The preclosure hydrology program calls for meteorological data from geohydrology program Studies 8.3.1.2.1.1, 8.3.1.2.1.3, and 8.3.1.2.2.1.

Presently no single study encompasses all the meteorological monitoring needed to characterize the site because meteorological data are needed by four different programs for slightly different purposes. For example, the meteorology program needs those parameters that define atmospheric dispersion characteristics, the geohydrology program needs precipitation-related parameters, and the climate program needs meteorological characteristics that relate to regional climate. All the programs, however, need to be coordinated to avoid a duplication of monitoring efforts and to effectively make use of technical experts within each of the programs.

The plan will present a description of all the programs that call for meteorological data, a more complete explanation of why each program needs the data, the parameters that will be measured for the program, and any links between the monitoring efforts. An evaluation of each of the monitoring programs will also be conducted to ensure that adequate data are being collected to satisfy the identified needs. The plan will also include the developing of most of an integrated network of meteorological stations that will incorporate the needs of all the programs. All these efforts will be coordinated among the programs and will use the collective experience and discipline-specific needs of the participants involved. Some of the monitoring programs involved are ongoing or will be expanded as site characterization proceeds.

Methods and technical procedures

There are no specific methods or technical procedures associated with development of the plan for synthesis of project meteorological monitoring.

8.3.1.12.1.3 Application of results

The information derived from the study described previously will be used in the following information needs and investigations:

<u>Investigation or information need</u>	<u>Subject</u>
8.3.1.2.1	Description of the regional hydrologic system
8.3.1.2.2	Description of the unsaturated zone system at the site
8.3.1.5.1	Nature and rates of change in climatic conditions to predict future climates
2.1.1	Site and design information needed to assess preclosure radiological safety (Section 8.3.5.3.1)

CONSULTATION DRAFT

<u>Investigation or information need</u>	<u>Subject</u>
2.1.3	Determination that public radiation exposures resulting from the releases of radioactive material from the repository combined with exposures from offsite installations and operations meet applicable requirements
2.3.4	Determination that projected public exposures and exposure conditions under accident conditions meet applicable requirements (Section 8.3.5.5.3)
2.5.1	Determination that the site is not disqualified and is not likely to be disqualified for each of the disqualifying conditions (Section 8.3.5.6.1)
2.5.2	Determination that the site meets the qualifying conditions of the technical guidelines and is likely to continue to meet the qualifying conditions (Section 8.3.5.6.2)
2.7.1	Site information needed for design (Section 8.3.2.3.1)
8.3.1.12.2	Atmospheric and meteorological phenomena at potential locations of surface facilities
8.3.1.12.3	Location of population centers relative to wind patterns in the general region of the site

8.3.1.12.1.4 Schedule and milestones

This investigation, addressing regional meteorology, contains two studies: 8.3.1.12.1.1 (characterization of the regional meteorological conditions) and 8.3.1.12.1.2 (plan for synthesis of NNWSI Project meteorological monitoring). In the figure that follows, the schedule information for these studies is presented in the form of timelines. The timelines extend from initiation of the study to the issuance of the final product associated with the study. Summary schedule information for this investigation can be found in Section 8.5.1.1.

Both studies in this investigation are ongoing. However, Study 8.3.1.12.1.1 is constrained by Study 8.3.1.12.2.1 (meteorological data collection at the Yucca Mountain site), which provides data for analysis of regional meteorological conditions. Study 8.3.1.12.1.2 is not constrained by any other program element.

Study 8.3.1.12.1.1 will provide input to the performance and design issue that assess preclosure radiological safety aspects of the mined geologic disposal system under normal and accident conditions (Issues 2.1, 2.2, 2.3, 2.5, and 2.7, Sections 8.3.5.3, 8.3.5.4, 8.3.5.5, 8.3.5.6, and 8.3.2.3,

CONSULTATION DRAFT

respectively). The meteorological studies will be conducted in parallel with performance assessment and design activities and will interact with them in an iterative fashion.

The data from Investigation 8.3.1.12.1 will also be used by the geohydrology and the climate programs (Sections 8.3.1.2 and 8.3.1.5, respectively). The meteorological studies will be conducted in parallel with these programs.

The study numbers and titles corresponding to each timeline are shown on the left side of the following figure. The points on the timeline represent major events or important milestones associated with the study. Solid lines represent study durations, and dashed lines show interfaces. The data input and output at the interfaces are shown by circles.

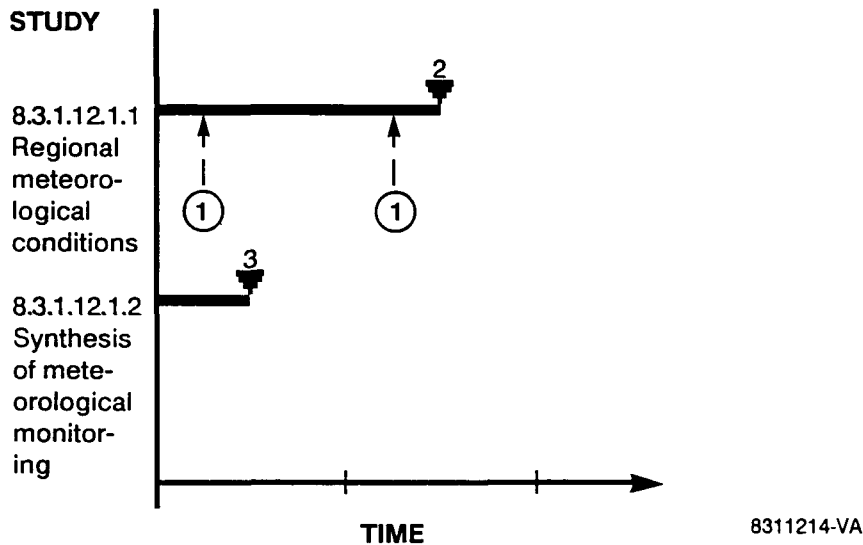

The points on the timeline and the data input and output at the interfaces are described in the following table:

<u>Point number</u>	<u>Description</u>
1	Data available from Study 8.3.1.12.2.1 (meteorological data collection at the Yucca Mountain site) for use in preparing report on regional meteorological conditions.
2	Milestone Q032. Issue report on regional meteorological conditions.
3	Milestone Z419. Issue plan for synthesis of the meteorological monitoring conducted as part of the NNWSI Project. The plan will determine the manner in which to expand the existing meteorological monitoring network.

CONSULTATION DRAFT

8.3.1.12.2 Investigation: Studies to provide data on atmospheric and meteorological phenomena at potential locations of surface facilities

Technical basis for obtaining the information

Link to the technical data chapters and applicable support documents

None of the technical data chapters provides an in-depth description of the site meteorological monitoring program. Section 5.1 of the SCP contains a brief summary of the program, and a detailed description can be found in the Meteorological Monitoring Plan (SAIC, 1985b).

Parameters

The following meteorological parameters are being monitored at the Yucca Mountain site:

1. Wind speed.
2. Wind direction.
3. Ambient temperature.
4. Atmospheric moisture.
5. Precipitation.
6. Atmospheric stability (calculated from either wind speed and standard deviation of wind direction or wind speed and net (solar and terrestrial) radiation).
7. Barometric pressure.

Each of these parameters is recorded as an hourly average and summarized in monthly and quarterly data reports.

Purpose and objectives of the investigation

The purpose of this investigation is to collect site-specific meteorological data that can be used in calculating doses to workers, including workers in restricted areas, and the general public under routine and accident scenarios.

Technical rationale for the investigation

One of the primary mandates of the Nuclear Waste Policy Act and associated siting guidelines is to ensure that releases from the repository system do not result in exposures to workers or the public in excess of applicable standards. Compliance with this requirement must be demonstrated before construction of the facility and is generally accomplished through dispersion modeling as explained in Section 8.3.1.12.2.2.2. Although the

information summarized for Section 8.3.1.12.1 (regional meteorological conditions) will provide a thorough understanding of the general wind flow patterns, atmospheric dispersion characteristics, temperature, and precipitation throughout the region, site-specific data from the proposed facility locations is needed to fully assess the potential impacts of releases. This is especially true for Yucca Mountain because the terrain in the immediate vicinity is quite complex, which results in micro-meteorological differences within relatively short distances. Regional conditions are, therefore, not sufficient in determining very-near-site meteorology.

To ensure that the meteorology specific to Yucca Mountain was completely evaluated, a monitoring network of five towers was installed and began operation in December 1985. The locations of these towers within the study area is shown in Figure 8.3.1.12-1. Two of the towers are located near potential facility locations: one tower is near the proposed repository surface facilities location and the other is near the proposed exploratory shaft site. If selected as a repository, the exploratory shaft at Yucca Mountain would be incorporated into the repository design as a ventilation shaft, so data from this site are quite important. Site-specific dispersion parameters, which will be used to calculate concentrations and subsequent doses, are required to satisfy this investigation.

The rationale for the meteorological monitoring program that has been implemented at Yucca Mountain, and the requirements for accuracy, calibration, auditing, reporting, and operating such a program were derived from a variety of rules, regulations, and guidelines. These governing documents are discussed in the following paragraphs.

Both the EPA and the NRC have promulgated regulations or guidelines outlining the meteorological data required to conduct certain environmental analyses, but none are specific to deep geologic repositories. The NRC regulations (10 CFR Part 60) under which a construction authorization and license for the repository would be issued have been approved, but they do not outline the scope and nature of the environmental analyses required to support those decisions. In lieu of specific guidelines concerning meteorological monitoring requirements, the Yucca Mountain monitoring program has been based on an understanding of the types of information (data and analyses) required by the NRC for licensing other nuclear facilities (e.g., reactors, reprocessing plants, spent fuel storage facilities). The primary NRC regulatory guideline that deals specifically with meteorological monitoring programs (NRC, 1980) is not repository specific but is, nonetheless, useful in helping to define the scope of the Yucca Mountain monitoring program. Sections C.2 (Siting of Meteorological Instruments), C.3 (Data Recorders), C.4 (System Accuracy), C.5 (Instrument Maintenance, Servicing Schedules, and Data Availability), and C.6 (Data Reduction and Compilation) of Regulatory Guide 1.23 (NRC, 1980) were evaluated for guidance in developing the monitoring network. To ensure that the monitoring programs implemented at Yucca Mountain would provide meteorological data acceptable for use in nonradiological regulatory permitting requirements, the program was also designed to comply with the EPA monitoring requirements for the Prevention of Significant Deterioration (40 CFR Part 58). The data these agencies require are to be used in addressing two aspects of repository development: (1) the potential for degrading the air quality in the vicinity of the repository by

CONSULTATION DRAFT

construction and excavation activities and (2) the role site-specific meteorological conditions would have in effectively dispersing routine operational and accidental releases from the repository.

The specific NRC Regulatory guides reviewed to ensure responsiveness to evaluating expected and potential atmospheric releases are Regulatory Guides 4.17 (Standard Format and Content of Site Characterization Reports for High-Level-Waste Geologic Repositories), 4.18 (Standard Format and Content of Environmental Reports for Near-Surface Disposal of Radioactive Waste), 4.2 (Preparation of Environmental Reports for Nuclear Power Stations, Revision 2), 1.70 (Standard Format and Content of Safety Analysis Reports for Nuclear Power Plants, LWR Edition, Revision 3), and 3.8 (Preparation of Environmental Reports for Uranium Mills).

8.3.1.12.2.1 Study: Meteorological data collection at the Yucca Mountain site

The purpose of conducting meteorological monitoring at Yucca Mountain is to provide data that can be used in resolving design and performance issues associated with preclosure radiological safety. This study consists of two activities, one that deals strictly with collecting the meteorological data and the other dealing with processing the data into dispersion-specific parameters.

8.3.1.12.2.1.1 Activity: Site meteorological monitoring program

Objectives

The objective of the site monitoring program is to collect meteorological data at potential locations of surface facilities and at a sufficient number of additional locations deemed necessary to characterize the wind flow patterns in the vicinity of Yucca Mountain.

These data must be suitable for use in dispersion models that will be used in assessing radiological impacts resulting from repository operations. Discussion on the use and applicability of the output of these dispersion models is presented under Information Need 2.7.1 (Section 8.3.2.3.1). Another objective of the site monitoring program, although not related to resolution of this information need, is to provide data that are suitable for permitting and licensing activities for both site characterization and repository development.

Parameters

The following meteorological parameters are measured or calculated from measured values and summarized as hourly averages at the five Yucca Mountain site locations discussed in the following description section:

1. Wind speed.
2. Wind direction.

CONSULTATION DRAFT

3. Ambient temperature.
4. Atmospheric moisture.
5. Precipitation.
6. Atmospheric stability.

Description

A detailed description of the site-monitoring activities can be found in the Meteorological Monitoring Plan (SAIC, 1985b) and is summarized below. All activities are conducted in accordance with the NNWSI Project Quality Assurance Program Plan (SAIC, 1986a).

Five sites in the vicinity of Yucca Mountain were chosen as monitoring locations. These sites are shown in Figure 8.3.1.12-1 and are further identified in Table 8.3.1.12-2.

The main meteorological tower (NTS-60 Repository) is located at an elevation of 1,143 m (3,751 ft) above mean sea level (MSL) near the proposed repository surface facility location. This area is bounded on the west by Yucca Mountain with peak elevation nearly 1,523 m (5,000 ft) above MSL and partially blocked from Jackass Flats to the east by three intermediate buttes with elevations of up to approximately 1,220 m (4,000 ft) above MSL. Data collected at this location will be used in assessing impacts associated with repository operations if the project proceeds to permitting activities.

The other four towers will be used to collect data on overall meteorological conditions in the area so that the site-specific data from the repository site can be interpreted more realistically. Data from these four remote sites will be particularly useful in characterizing terrain-induced perturbations that may significantly influence dispersion and transport of emissions.

The first of these remote locations is along the north-south trending ridge of Yucca Mountain approximately 3.9 km west-northwest of the main site at an elevation of 1,478 m (4,849 ft) above MSL, the highest elevation of any of the towers. This tower, NTS-10 Yucca Mountain, is 10 m high, and there are virtually no obstructions in any direction. Data from this site should be indicative of synoptic-scale weather conditions some of the time. Comparison of this data with the data from NTS-60 Repository during such times could provide insight into the relationship between synoptic-scale conditions and those that can be expected to occur at the surface facilities.

A second 10-m tower is located at the proposed site of the exploratory shaft, which is 2.7 km (1.7 miles) west-northwest of the main site at an elevation of 1,278 m (4,193 ft) above MSL. This tower is referred to as NTS-10 Coyote Wash and is located in one of the many drainages along the eastern side of Yucca Mountain. Data from this tower will be used primarily to assess impacts from exploratory shaft operations, but will also be used in the overall site evaluation.

A third 10-m tower is located at Alice Hill, one of the buttes separating the project area from Jackass Flats. This site is 3.0 km (1.9 miles) northeast of the main site at an elevation of 1,234 m (4,047 ft) above MSL and is referred to as NTS-10 Alice Hill. This tower is located such that

CONSULTATION DRAFT

Table 8.3.1.12-2. Meteorological monitoring sites operated by the Nevada Nuclear Waste Storage Investigations Project

Site	UTM ^a Coordinates Zone 11(m)	Nevada System (ft)	Latitude- longitude	Elevation (above, ^b MSL)
NTS-60 Repository	550,776E	569,127E	36°50'33"	3,751 ft
	4,077,427N	761,795N	116°25'49"	1,143 m
NTS-10 Yucca Mountain	547,660E	558,862E	36°51'20"	4,849 ft
	4,078,781N	766,434N	116°28'19"	1,478 m
NTS-10 Coyote Wash	548,884E	562,876E	36°51'17"	4,193 ft
	4,078,689N	766,195N	116°27'05"	1,278 m
NTS-10 Alice Hill	553,122E	576,810E	36°51'51"	4,047 ft
	4,079,787N	769,661N	116°24'14"	1,234 m
NTS-10 Forty- mile Wash	554,396E	580,882E	36°45'51"	3,124 ft
	4,068,691N	733,230N	116°23'27"	952 m

^aUTM = Universal Transverse Mercator.

^bMSL = mean sea level.

data from NTS-10 Yucca Mountain, NTS-10 Coyote Wash, and NTS-10 Alice Hill will provide a cross-section of the atmosphere in the lee of Yucca Mountain. In addition, because NTS-10 Coyote Wash and NTS-10 Alice Hill are at approximately the same elevation, comparisons with the main site can be used to evaluate the characteristics of the drainage flow that may form between the ridges.

The final 10-m tower is placed at the edge of Fortymile Wash, 9.2 km (5.7 miles) southwest of the main tower, at an elevation of 952 m (3,124 ft) above MSL. This wash is the major surface-water drainage for the area, and it is expected to influence significantly the air drainage during times when rapid nocturnal surface cooling causes air near the surface to subside. Data from NTS-10 Fortymile Wash will indicate how far down-valley repository emissions would be transported under these drainage conditions.

All monitoring equipment and stations have been designed and sited to ensure that all probes and samplers meet or exceed applicable EPA and NRC requirements and guidelines.

The meteorological sensors on the proposed 10-m towers are mounted at the top of the tower, precluding tower-induced turbulence interference. For the 60-m tower, wind speed and direction sensors will project approximately

CONSULTATION DRAFT

1.8 m (5.9 ft) from the tower in the direction of the prevailing wind to minimize tower-induced turbulence effects.

The four 10-m towers are instrumented identically to measure wind speed, wind direction, sigma theta (standard deviation of horizontal wind direction) for determination of atmospheric stability, relative humidity, and temperature at the 10-m level. The 60-m meteorological tower is instrumented to measure or calculate wind speed, wind direction, and sigma theta at the 10- and 60-m levels; sigma phi (standard deviation of vertical wind direction), temperature, and relative humidity at the 10-m level; temperature difference between the 10- and 60-m levels; net radiation (solar and terrestrial) at the 3-m level; and precipitation at essentially ground level a short distance from the base of the tower. The sensors at the 10-m level satisfy the requirement of applicable monitoring guidelines for monitoring meteorological parameters at the standard exposure heights over level, open terrain. The NTS-10 Coyote Wash and NTS-10 Fortymile Wash 10-m towers will be located so as to characterize particular drainage and terrain-induced flow patterns to help define site-specific conditions. The sensors at the 60-m level will provide an indication of larger-scale wind flow patterns. Other details of the monitoring program, such as temperature sensor ventilation and shielding, net radiometer (solar and terrestrial) exposure, and precipitation gauge heating (for water equivalent measurements of snow) are all designed to be in full compliance with acceptable meteorological practice and applicable EPA and NRC regulations and guidelines.

Instrument specifications and station design. Meteorological parameters at all four remote sites will be monitored using continuous analyzers to provide hourly average wind speed, wind direction, sigma theta, relative humidity, and temperature. Power will be supplied by batteries that are trickle-charged by solar cells. Continuous recording of the data on strip charts is not feasible at these sites because of the lack of available commercial electrical power. With this exception, the meteorological equipment and methodologies will be in accord with referenced EPA and NRC rules, regulations, and guidelines.

All meteorological parameters at the main site will also be monitored using continuous analyzers. The continuously recorded meteorological parameters will be reduced and averaged (scalar and/or vector, if appropriate) to produce the following meteorological data base:

1. Hourly average wind speed (10- and 60-m levels).
2. Hourly average wind direction (10- and 60-m levels).
3. Hourly average standard deviation of horizontal wind direction (10- and 60-m levels).
4. Hourly average atmospheric stability based on Pasquill Stability Category using continuous sigma theta monitoring (with differential temperature, sigma phi, and net radiation data as backup).
5. Hourly average surface temperature at standard height for climatic comparisons and plume rise calculations.

CONSULTATION DRAFT

6. Hourly average differential temperature measurements between the 10- and 60-m tower levels.
7. Hourly average dewpoint temperature.
8. Hourly precipitation amounts for climatic comparisons.

Except as noted above, meteorological analyzers, equipment, and methodologies will be in accord with applicable EPA and NRC rules, regulations, and guidelines, and will be purchased, installed, and monitored in compliance with NNWSI Project quality assurance requirements.

Instrument specifications will meet or exceed those given in applicable EPA and NRC rules, regulations, and guidelines. Where agency specifications differ, the more stringent specification has been used in designing the monitoring program. The specifications are as follows:

1. Wind direction: $\pm 3^\circ$ of true azimuth (including sensor orientation error) with a starting threshold of less than 0.45 m/s (1 mph).
2. Wind speed: ± 0.22 m/s (0.5 mph) for speeds above the starting threshold of 0.45 m/s (1 mph) but less than 11.1 m/s (25 mph), and ± 5 percent of true speed, not to exceed 2.5 m/s (5.6 mph), at speeds greater than 11.1 m/s (25 mph).
3. Sigma theta: wind vane damping ratio of between 0.4 and 0.6 (inclusive) with a 15° deflection and delay distance not to exceed 2 m.
4. Temperature: $\pm 0.5^\circ\text{C}$ (0.9°F).
5. Temperature difference (between levels): $\pm 0.003^\circ\text{C}$ (0.005°F) per meter.
6. Radiation (solar and terrestrial): ± 5 percent.
7. Precipitation: resolution of 0.25 mm (0.01 in) with recorded accuracy of ± 10 percent of total accumulated catch.
8. Time: within 5 minutes of actual time for all recording devices.

These specifications apply to digital systems; analog backup systems can deviate by up to 1.5 times these values.

Data reporting. The meteorological and quality control data collected during the monitoring program will be summarized in three types of reports: monthly reports at the end of each monitoring month that will be for internal data verification only, quarterly reports prepared after each monitoring quarter, and annual reports summarizing each baseline monitoring year.

The quarterly reports will contain a quality-assured (i.e., in accordance with written, approved procedures and instructions) listing of the meteorological data collected at each site during the previous quarter by month. A discussion of the data recovery rates and significant project

CONSULTATION DRAFT

activities will also be included in these reports. The monthly reports will serve to track the technical aspect of the monitoring program.

The content and basic format for the monthly, quarterly, and annual data reports will be in a format and scope consistent with reporting requirements for the EPA, NRC, and the State of Nevada, and shall be in accordance with supplemental written and approved instructions. All reports will provide an indication of progress to date, a review of all site activities during the period of record, problems encountered and their resolution, percentage data recovery rates, calibration-audit reports, and other pertinent information.

The quarterly reports will also contain a summary description of the site equipment and operating methodologies and a hard copy of the hourly data listing for each parameter monitored as a second volume. A wind rose for each site showing the percent frequency distribution of wind speed and direction will also be included in each report. In addition, the quarterly reports will include a description of quality assurance and of quality control activities for the quarter.

The annual report will contain discussions and data similar to the monthly and quarterly reports but summarized for the entire monitoring year. In addition, meteorological summaries such as wind direction and speed persistence, diurnal variations, seasonal variations, and meteorological influences will be presented and discussed. Also the annual report will present a chronology of data recovery detailing the annual data recovery rates by parameter. The joint frequency of wind speed, wind direction, and atmospheric stability will be presented and discussed in terms of persistence and frequency of occurrence. These data will be in a form suitable for use in air quality modeling analyses and for modeling potential radiological impacts.

Methods and technical procedures

The methods and procedures for Activity 8.3.1.12.1.2.1.1 are given in the following table.

Method	Technical procedure		Date
	Number	Title	
Collection of meteorological data	DOE/NV/10270-5 SAIC 84/7600	Meteorological Monitoring Plan	9 Jul 85
Collection of meteorological data (continued)	SAIC 85/8002	Instructions for receipt, acceptance testing, and perform- ance auditing of meteorological monitoring equipment	20 Jan 86

CONSULTATION DRAFT

Method	Technical procedure		Date
	Number	Title	
	SAIC 86/8000	Instructions for operation and calibration checks of meteorological monitoring equipment	30 Apr 86
	TBD ^a	Data Processing Instructions (in preparation)	TBD

^aTBD = to be determined.

8.3.1.12.2.1.2 Activity: Data summary for input to dose assessments

Objectives

The objective of this activity is to process the meteorological data collected as a result of Activity 8.3.1.12.2.1.1 into a format and content that will be useful in assessing radiological impacts, as required by the design and performance issues.

Parameters

The parameters listed in Activity 8.3.1.12.2.1.1 (from one or more sites) will be used in combination with an estimate of the mixing layer depth to calculate a concentration parameter: χ/Q . This parameter is calculated using dispersion models, and represents the concentration χ over the emission rate Q . χ/Q s will be calculated for several locations at various distances from the surface facilities. Calculating χ/Q s as opposed to concentrations allows the source term Q to be varied without rerunning the model, as needed for determining doses under accident versus routine emission scenarios.

Description

The concentration (χ/Q) values will be calculated using a dispersion model that is capable of simulating the meteorological and topographical influences on material emitted to the atmosphere as it is transported and dispersed downwind. A variety of models have been developed for this purpose, but most are appropriate only for use in flat or gently rolling terrain. The topography of the Yucca Mountain site, however, warrants the use of a model that can simulate complex terrain effects. Both the EPA and the NRC have issued documents that provide guidance on the selection and use of the various models that have been developed. This guidance will help ensure that the appropriate model is used.

CONSULTATION DRAFT

The NRC has issued at least four regulatory guides that either reference, provide examples of, or suggest the use of models to determine χ/Q values, but none of them were developed specifically for geologic repositories. However, some of the information in these guidelines will be applicable to a repository. These guides are (1) Regulatory Guide 1.109--Calculation of Annual Doses to Man from Routine Releases of Reactor Effluents for the Purpose of Evaluating Compliance with 10 CFR Part 50, Appendix I (NRC, 1977a); (2) Regulatory Guide 1.111--Methods for Estimating Atmospheric Transport and Dispersion of Gaseous Effluents in Routine Releases from Light-Water-Cooled Reactors (NRC, 1977d); (3) Regulatory Guide 1.145--Atmospheric Dispersion Models for Potential Accident Consequence Assessments at Nuclear Power Plants (NRC, 1982a); and (4) Regulatory Guide 3.8--Preparation of Environmental Reports for Uranium Mills (NRC, 1982c). These documents will be reviewed to ensure that the dispersion analysis done for Yucca Mountain is comprehensive enough to satisfy typical NRC requirements.

The guidance for the EPA is contained within the guideline on air quality models (EPA, 1986). The EPA has also developed and provides a magnetic tape containing a variety of the approved and most frequently used models. Although the EPA models are aimed at assessing nonradiological impacts, χ/Q values can be calculated using these models as well.

The χ/Q values will be calculated at discrete locations, but the receptor grid is arbitrary in that no specific sites have been selected for evaluation. Instead, a radial receptor grid will be used and χ/Q values at distances of 4, 8, 16, 24, 32, 40, 48, 56, 64, 72, and 80 km from an assumed source will be calculated in each of the 16 cardinal directions for a total of 176 receptors.

To ensure responsiveness to the design and performance issues, χ/Q s representing routine and accident release scenarios must be developed. Routine releases will be evaluated by calculating an annual average χ/Q value at each of the receptors. Because the accident scenarios must be evaluated under meteorologically worst-case conditions (in terms of dispersion), one-hour χ/Q values also will be required.

Other data needed as input to a dispersion model are one year of hourly sequential meteorological data (wind speed, wind direction, temperature, mixing height, and Pasquill stability class), receptor terrain heights and their Universal Transverse Mercator (UTM) coordinates, and source characteristics (UTM coordinates, stack height, stack diameter, exit gas velocity, exit gas temperature, and building-stack configuration). Once all these data have been put in the format required by the model, the model is run. Although the basic equations used in calculating an χ/Q value are not exceptionally complex, the large number of calculations required for a year of hourly meteorological data dictates the use of a computer.

A report presenting the χ/Q values and the information used in calculating those values will be prepared at annual intervals for up to 5 years.

Methods and technical procedures

The method and procedure for Activity 8.3.1.12.2.1.2 is given in the following table.

CONSULTATION DRAFT

Method	Technical procedure		Date
	Number	Title	
Dispersion modeling	TBD ^a	Instructions for performing dispersion analyses	TBD ^a

^aTBD = to be determined.

8.3.1.12.2.2 Application of results

The meteorological data and resultant dispersion parameters will be used in the following information needs dealing with routine and accident scenarios:

<u>Information need</u>	<u>Subject</u>	<u>SCP section</u>
2.1.1	Site and design information needed--public radiological exposures from normal conditions	8.3.5.3.1
2.2.2	Project worker exposures--normal conditions	8.3.5.4.2
2.3.1	Credible repository accidents	8.3.5.5.1
2.3.2	Projected accidental releases	8.3.5.5.2

In addition, the meteorological data will provide input to Investigations 8.3.1.2.1, 8.3.1.2.2, 8.3.1.5.1, and 8.3.1.14.3.

8.3.1.12.2.3 Schedule and milestones

This investigation, addressing site meteorology, contains one study: 8.3.1.12.2.1 (meteorological data collection at the Yucca Mountain site). In the figure that follows, the schedule information for this study is presented in the form of a timeline. The timeline extends to the issuance of the final products associated with the study. Summary schedule information for this investigation can be found in Section 8.5.1.1.

The site meteorological monitoring program was implemented in December 1985 and is ongoing. Meteorological data collection is not constrained by other program elements; no input is required from other investigations or activities.

CONSULTATION DRAFT

Meteorological data are required input to Study 8.3.1.12.1.1 (characterization of the regional meteorological conditions) and Study 8.3.1.12.4.1 (characterize the potential extreme weather phenomena and their recurrence intervals). The data from Study 8.3.1.12.2.1 will also be used by the geohydrology and the climate programs (Sections 8.3.1.2 and 8.3.1.5, respectively). The meteorological data also support performance and design issues related to routine operation of the repository and accident scenarios (Sections 8.3.2 and 8.3.5). The meteorological studies will be conducted in parallel with these programs and will interact with them in an iterative fashion.

The study number and title corresponding to the timeline are shown on the left side of the following figure. The points on the timeline represent major events or important milestones associated with the study. Solid lines represent study durations, and dashed lines show interfaces. The data input and output at the interfaces are shown by circles.

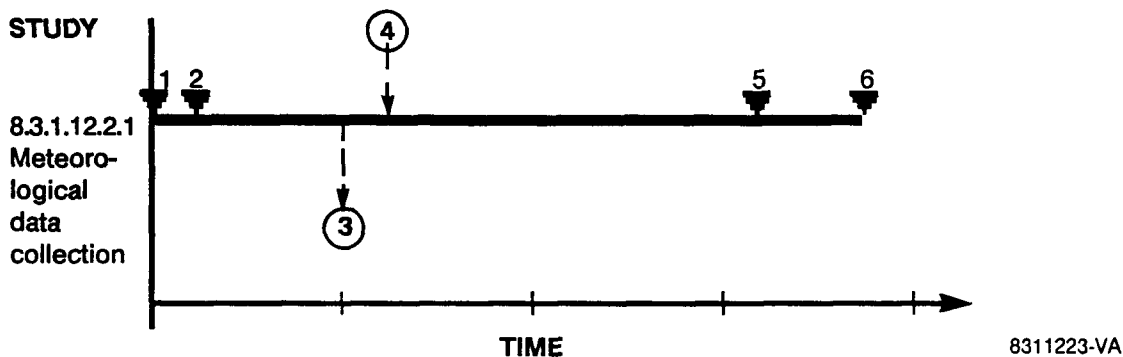

The points on the timeline and the data input and output at the interfaces are described in the following table:

<u>Point number</u>	<u>Description</u>
1	Issue seventh quarterly meteorological data report.
2	Issue second annual meteorological data report.
3	Data available for Study 8.3.1.12.1.1 for report on regional meteorological conditions.
4	Data available for Study 8.3.1.12.4.1 for report on extreme weather phenomena possible at Yucca Mountain.
5	Milestone Z423. Issue fifth and final annual report on average and unfavorable χ/Q values.
6	Milestone M393. Issue five-year summary report on meteorological conditions.

CONSULTATION DRAFT

8.3.1.12.3 Investigation: Studies to provide data on the location of population centers relative to wind patterns in the general region of the site

Technical basis for obtaining the information

Link to the technical data chapters and applicable support documents

The only data contained within the SCP relative to this investigation is in Section 5.1 (recent climate and meteorology). The preliminary finding relative to the qualifying condition associated with this investigation is contained in Chapter 6 of the Yucca Mountain environmental assessment (DOE, 1986b).

Parameters

The following summaries will be calculated using data from the site monitoring program (Activity 8.3.1.12.2.1.1) or from data gathered as a result of Investigation 8.3.1.12.1, regional meteorological conditions:

1. Frequency distribution of wind speed and direction.
2. Persistence of wind speed and direction.
3. Diurnal wind speed and direction.
4. Atmospheric dispersion associated with these summaries in parameters 1,2, and 3 (if appropriate).

Purpose and objectives of the investigation

The purpose of this investigation, similar to Investigation 8.3.1.12.1, is to provide data on wind flow patterns in the general region of Yucca Mountain. These data will then be used in estimating doses to the public and in doing so ensure that wind flow patterns would not preferentially transport material towards population centers.

Technical rationale for the investigation

The qualifying condition for meteorology (10 CFR 960.5-2-3) requires an evaluation of the potential for preferential transport of radioactive emissions toward population centers in the vicinity of the site. Although a preliminary assessment was conducted for the Yucca Mountain environmental assessment (EA) (DOE, 1986b) using existing regional data, site-specific meteorological data are needed to supplement the conclusions reached in the EA.

The population density and distribution data will be collected as part of the population density program (Section 8.3.1.10). The meteorological data gathered and summarized as part of Investigations 8.3.1.12.1 and 8.3.1.12.2 should provide sufficient data in combination with the population data for satisfying this investigation. Assimilation of the population and meteorological data into dose calculations will make use of the data generated in Activity 8.3.1.12.2.1.2 and will be completed as part of Information

CONSULTATION DRAFT

Need 2.5.2 (Section 8.3.5.6.2) and Issues 2.1 (Section 8.3.5.3) and 2.3 (Section 8.3.5.5).

8.3.1.12.3.1 Application of results

The information from this investigation together with the data associated with the population density program will be used in calculating doses to members of the public under routine and accident scenarios (Issues 2.1 and 2.3).

8.3.1.12.3.2 Schedule and milestones

All schedules and milestones are described in Sections 8.3.1.12.1 (regional meteorological conditions) and 8.3.1.12.2 (meteorological conditions at potential surface facility locations).

8.3.1.12.4 Investigation: Studies to provide data on potential extreme weather phenomena and their recurrence intervals

Technical basis for obtaining the information

Link to the technical data chapters and applicable support documents

Section 5.1 (recent climate and meteorology) provides a technical summary of existing data relevant to this investigation.
Parameters

The following parameters will be evaluated using existing historical data bases and technical publications:

1. Frequency of severe storms (tornadoes, hurricanes, etc.).
2. Magnitude and frequency of extreme wind speeds.
3. Extremes of temperature and humidity.
4. Precipitation extremes (including hail and snow) and their recurrence intervals.
5. Frequency and intensity of fog.

Purpose and objectives of investigation

The purpose of this investigation is to assimilate data that can be used in evaluating the impact of extreme weather phenomena on surface facilities.

CONSULTATION DRAFT

Technical rationale for the investigation

Extreme weather phenomena cannot be resolved from short-term, site-specific monitoring programs. Long-term meteorological and climatological data records must be used to provide a sufficient data base upon which to develop statistical predictions of extreme events along with their recurrence intervals.

The identification of extreme conditions is necessary to provide design information for the repository surface facilities. All structures must be designed for the meteorological conditions that may be experienced over the life of the facilities. Examples of how meteorological data will influence design are as follows:

1. Temperature and humidity extremes will affect the design of heating and cooling systems.
2. Precipitation extremes will provide data for the design of containment basins, diversion channels, and culverts.
3. Snow and hail data will provide input to the design of roof loadings and external facilities.
4. Extreme wind speed estimates will provide critical design criteria for surface facility structures.
5. The frequency and intensity of fog, dust storms, and other severe storms will be used to design lighting and emergency facilities and will be factored into the accident analyses relative to the repository.

8.3.1.12.4.1 Study: Characterize the potential extreme weather phenomena and their recurrence intervals

Objectives

The objective of this study will be to evaluate the existing historical meteorological and climatological records, technical publications, and other relevant information to quantify the extreme weather phenomena that may be expected at the Yucca Mountain site and determine their recurrence interval.

Parameters

1. Frequency of severe storms.
2. Magnitude and frequency of extreme wind speeds.
3. Extremes of temperature and humidity.
4. Precipitation extremes.
5. Frequency and intensity of fog.

Description

Existing data bases and technical publications will be reviewed to characterize the extreme weather phenomena that may be experienced at the site. Where necessary, calculations (e.g., statistical extrapolations) may be made to interpolate existing data to develop site-specific estimates. The data from the site-monitoring program will also be compared with the extreme data.

8.3.1.12.4.2 Application of results

The information derived from the activities described previously will be used in the following investigations for repository design:

<u>Information need</u>	<u>Subject</u>
2.2.1	Site and design information needed to assess preclosure radiological safety (Section 8.3.5.4.1)
2.7.1	Site information needed for design (Section 8.3.2.3.1)

8.3.1.12.4.3 Schedule and milestones

This investigation contains one study: 8.3.1.12.4.1 (characterize the potential extreme weather phenomena and their recurrence intervals). In the figure that follows, the schedule information for this study is presented in the form of a timeline. The timeline extends to the issuance of the final products associated with the study. Summary schedule information for this investigation can be found in Section 8.5.1.1.

Although the meteorological monitoring program is ongoing, this study is planned to begin in the second year of site characterization. This is because Study 8.3.1.12.4.1 is constrained by the availability of meteorological data from Study 8.3.1.12.2.1 (meteorological data collection at the Yucca Mountain site).

Study 8.3.1.12.4.1 will provide input to the performance issue that is to assess preclosure radiological safety (Issue 2.2) and to the repository surface-facility design issue (Issue 2.7). The meteorology studies will be conducted in parallel with performance assessment and design activities.

The study number and title corresponding to the timeline are shown on the left side of the following figure. The point on the timeline represents an important milestone associated with the study. Solid lines represent study durations, and dashed lines show interfaces. The data input and output at the interfaces are shown by circles.

CONSULTATION DRAFT

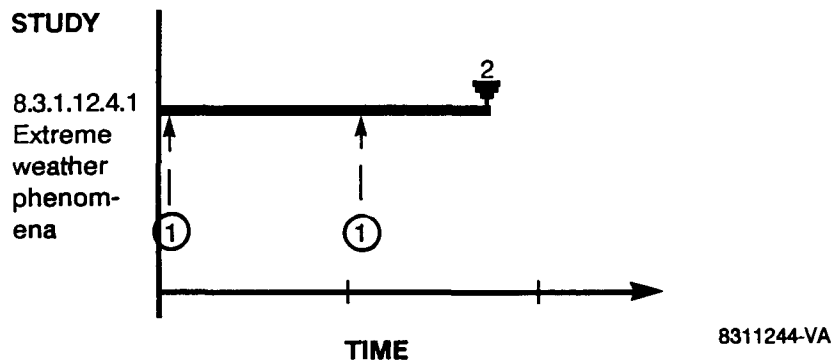

The points on the timeline and the data input and output at the interfaces are described in the following table:

<u>Point number</u>	<u>Description</u>
1	Meteorological data available from Study 8.3.1.12.2.1.
2	Milestone Q033. Issue report on extreme weather phenomena and expected recurrence intervals at Yucca Mountain.

***Nuclear Waste Policy Act
(Section 113)***

Section 8.3.1.13

Consultation Draft

OFFSITE INSTALLATIONS

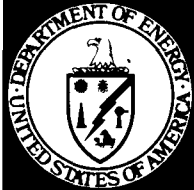

Site Characterization Plan

***Yucca Mountain Site, Nevada Research
and Development Area, Nevada***

Volume V

January 1988

***U.S. Department of Energy
Office of Civilian Radioactive Waste Management
Washington, DC 20585***

CONSULTATION DRAFT

8.3.1.13 Overview of offsite installations and operations program: Description of the offsite installations and operations required by performance and design issues

Summary of performance and design requirements for offsite installations and operations information

This program provides the technical data required to support the resolution of the following performance and design issues:

<u>Performance or design issue</u>	<u>Short title</u>	<u>SCP section</u>
2.1	Radiological exposures to public--normal conditions	8.3.5.3
2.2	Worker radiological safety--normal conditions	8.3.5.4
2.3	Accidental radiological releases	8.3.5.5
2.5	Higher level finding--preclosure radiological safety	8.3.5.6
2.7	Repository design criteria for radiological safety	8.3.2.3

All these issues address preclosure radiological safety requirements for the repository. The investigations derived from these issues address the following topics: (1) the data base necessary to assess the potential offsite accident initiators, (2) possible radioactive releases from other sites that affect the site's ability to comply with radiological requirements, (3) location and adequacy of the transportation access routes, and (4) the agricultural and cultural data required for analysis of the public exposure. This program requires the identification of all offsite operations that could impact the site. Potential impacts of offsite operations are determined to support the calculation of ingestion doses and exposures to the public and workers for Issues 2.1, 2.2, and 2.3. The data base established in this program will also be used in an evaluation of the higher level findings required for the qualifying condition in the offsite installations technical guideline (10 CFR Part 960), and for the qualifying condition for the preclosure radiological safety system guideline (Issue 2.5).

Approach to satisfy performance and design requirements

The data base presented in the environmental assessment (DOE, 1986b) describes the nearby offsite installations and operations that could potentially affect repository operations. Further information required to support resolution of design and performance issues related to radiological safety include the following:

1. An evaluation of offsite accident initiators, their probabilities and potential impacts, and the parameters required for calculation of public ingestion dose to support Issues 2.1 and 2.3.

CONSULTATION DRAFT

2. An assessment of releases from all nuclear fuel cycle operations to support Issues 2.1 and 2.5.
3. An assessment of the onsite impact of nonrepository-related routine and potential accidental releases of radioactive material to support Item 1 and to support resolution of Issues 2.2 and 2.5.
4. An evaluation of the adequacy of proposed transportation site access routes to support resolution of Issues 2.3 and 2.5.
5. The collection of agricultural and cultural data to support the calculation of the dose to the public from releases at the Yucca Mountain site and to support resolution of Issues 2.1 and 2.3.

Models and computer programs used in evaluating data and analyzing results or impacts will be verified and, if appropriate, validated in a manner consistent with the NNWSI Project Quality Assurance Program and the procedures normally used in the applicable technical discipline. These models and computer programs are addressed in Sections 8.3.5.19 and 8.3.5.20.

Interrelationships of offsite installations and operations investigations

The first investigation developed for this program addresses the requirement to document the presence of all nearby industrial, transportation, and military installations and operations, both nuclear and nonnuclear (Investigation 8.3.1.13.1). The second investigation requires an evaluation of the potential impacts of those nearby installations and operations (Investigation 8.3.1.13.2).

The investigations identified for nearby industrial, transportation, and military installations and operations (both nuclear and nonnuclear) consist of identifying the near-site operations, nuclear fuel cycle facilities, and nuclear facilities not associated with the nuclear fuel cycle in the area. Once these operations have been identified, the impacts of those facilities will be assessed. The planned activities for assessing impacts consist of evaluating (1) near-site operations, (2) nuclear fuel cycle facilities, (3) nuclear facilities not associated with the nuclear fuel cycle, (4) nuclear testing induced ground motion, (5) highway access routes to the site, and (6) rail access routes to the site.

Certain agricultural and cultural data are necessary for assessing radionuclide dose to the public. This information will not be collected as part of this program because this type of data is not considered part of site characterization activities as defined in the Nuclear Waste Policy Act (NWPA, 1983). However, these data are an essential component of the program of calculating doses to the public through the ingestion dose pathway and will be presented as part of the environmental program planning process within the NNWSI Project. Specific information on these data are addressed in the Radiological Monitoring Plan.

The schedule information provided for investigations in this section includes the sequencing, interrelationships, and relative durations of the activities in the investigation. Specific durations and start/finish dates for the activities are being developed as part of ongoing planning efforts

CONSULTATION DRAFT

and will be provided in the SCP at the time of issuance and revised as appropriate in subsequent semiannual progress reports.

8.3.1.13.1 Investigation: Determination of nearby industrial, transportation, and military installations and operations (nuclear and nonnuclear)

Technical basis for obtaining the information

Link to the technical data chapters and applicable support documents

The preliminary data currently available are contained in Sections 3.4.1, 3.4.7, 3.5, 3.6.1, 3.6.3, 5.3, and 6.2.1.5 of the Yucca Mountain environmental assessment (DOE, 1986b). Data for this investigation will be collected according to a transportation studies plan, a preliminary site characterization radiological monitoring plan, and a radiological monitoring plan, which are currently being developed.

Parameters

The parameters for this investigation are

1. A list of all nearby DOE, industrial, transportation, and military operations.
2. The scope and frequency of the operations in item 1.
3. Distance to all operations listed in item 1.
4. Estimates of potential radiological releases from the operations listed in item 1.
5. Meteorological parameters (from Program 8.3.1.12).

Purpose and objectives of the investigation

The data and parameters list includes those items considered important to assess impacts from nearby DOE, industrial, transportation, and military operations. The scope, frequency, and distance of these operations will provide the necessary detail for input to impact assessments relative to accident conditions. Estimates of potential radiological releases from nearby operations, along with measurements of meteorological parameters (Program 8.3.1.12) will provide additional detail for assessing radiological impacts nearby and the subsequent effect, if any, at the Yucca Mountain site. These parameters will be included in performance strategies as presented in the performance and design issues and ultimately used to address preclosure radiological safety aspects of the site.

Technical rationale for the investigation

The data on offsite operations collected under this investigation will be used to support an evaluation of potential accident initiators.

CONSULTATION DRAFT

Identification of nuclear fuel cycle operations covered by 40 CFR Part 190 is also required to support the assessment of compliance with 40 CFR 191.03(a).

The data collected will be used to (1) determine the probability and magnitude of exposures caused by abnormal events, and (2) determine the magnitude of any radiological releases from offsite nuclear fuel cycle facilities (40 CFR Part 190) to determine that these releases, when combined with the release from Yucca Mountain, will be within the allowable limits. This investigation consists of three activities collecting similar data types. The activities are separated because of the differences in how the data will be collected.

The following activities will identify all current DOE, industrial, transportation, and military operations and such operations projected for the future in the Yucca Mountain area. This data will be used to provide the data base for the evaluations described in Section 8.3.1.13.2.1.

8.3.1.13.1.1 Activity: Identify near-site activities

Objectives

The objective of this activity is to identify and describe all DOE, industrial, commercial, transportation, and military operations within 8 km of the Yucca Mountain site. In addition, significant operations outside this area, which could impact the site will also be evaluated. This will not include offsite radioactive materials transportation since this operation will be addressed by the Office of Storage and Transportation Systems and the environmental program planning efforts of the NNWSI Project. Offsite transportation is considered part of the transportation system and not part of the potential repository facility.

Parameters

The parameters of this activity are the description of (1) all industrial operations, (2) flight operations, (3) commercial, and (4) DOE operations within 8 km of the Yucca Mountain site. The Nevada Test Site (NTS) operations will be addressed separately under Activity 8.3.1.13.1.3.

Description

A review of military flight operations in the area is being conducted and will be documented in a report to be issued. A list of all existing and projected commercial operations in the area will be compiled. This will include a review of all public domain land use permits in the area for mining and other operations. In addition, the DOE management will be contacted to determine NTS operations near the site. Windshield survey observations from a motor vehicle of the local area will be conducted to complete the compilation of this list. Appropriate state agencies and other experts will project future operations, and specialists will determine if any of those operations could have an adverse impact on repository site operations. Activity 8.3.1.13.2.1 contains further details on the evaluation of near-site activities.

CONSULTATION DRAFT

Methods and technical procedures

There are no methods and technical procedures for this activity.

8.3.1.13.1.2 Activity: Identify nuclear fuel cycle facilities in the area

Objectives

The objective of this activity is to identify all nuclear fuel cycle facilities within 80 km of the Yucca Mountain site or within Nevada areas adjacent to Las Vegas.

Parameters

The parameters for this activity are

1. A list of all nuclear fuel cycle facilities within the specified area.
2. The data base to predict magnitudes of projected normal and accidental releases of radioactivity.

Description

The regional NRC office and the State organizations with similar responsibilities will be contacted to identify any nuclear fuel cycle facilities. The routine yearly release of radioactive material from all such facilities will be available because these values are required for routine reports to the NRC and state agencies. Also, potential accidental releases from the facilities will be obtained from safety evaluations of those facilities.

Methods and technical procedures

There are no methods and technical procedures for this activity.

8.3.1.13.1.3 Activity: Identify all nuclear facilities not associated with the nuclear fuel cycle near the Yucca Mountain site

Objectives

The objective of this activity is to characterize the impacts of all radiological operations at facilities within 80 km of the Yucca Mountain site that are not part of the nuclear fuel cycle. Because of the potential for classified information being associated with the identification of NTS operations, these operations will be characterized by their past effects on the Yucca Mountain area.

CONSULTATION DRAFT

Parameters

For the existing environment at Yucca Mountain, radionuclide concentration will be assessed in (but not limited to)

1. Air (particulate form).
2. Air (gaseous form).
3. Soil.
4. Surface water.
5. Sediments.
6. Biota.

In addition, the NTS environmental monitoring reports (produced yearly by various organizations) and any other available data will be reviewed to assess the impacts of past releases at the Yucca Mountain site and in the City of Las Vegas.

Description

All data collection will be conducted in a manner consistent with applicable regulatory guides, DOE guidance documents, and industry practices. Specific examples can be found in the Preliminary Site Characterization Radiological Monitoring Plan (SAIC, 1986b), which addresses data collection before the initiation of significant site characterization activities. The requirements for this activity are the radiological environmental monitoring and sampling equipment and services procured consistent with the studies identified. The equipment and services required include

1. Air sampling equipment.
2. Soil and water sampling equipment.
3. Ambient radiation monitoring equipment and services.
4. Laboratory analysis of air, soil, and water samples.

Methods and technical procedures

All data collection operations described for this activity will follow standard environmental radiological monitoring technical procedures. This data collection is addressed in the Radiological Monitoring Plan.

8.3.1.13.1.4 Application of results

The data from this investigation will be used in Investigation 8.3.1.13.2 described below.

8.3.1.13.1.5 Schedule and milestones

This investigation on nearby offsite installations and operations contains three activities: 8.3.1.13.1.1 (identify near-site activities), 8.3.1.13.1.2 (identify nuclear fuel cycle facilities in the area), and 8.3.1.13.1.3 (identify all nuclear facilities not associated with the nuclear

CONSULTATION DRAFT

fuel cycle). In the figure that follows, the schedule information for these studies is presented in the form of timelines. The timelines extend to the completion of data collection for each of the activities.

Activity 8.3.1.13.1.2 is ongoing; the other two activities are scheduled to begin within the first year of site characterization. Summary schedule information for this investigation can be found in Section 8.5.1.1.

Activities 8.3.1.13.1.1 and 8.3.1.13.1.2 are not constrained by any other program elements. Activity 8.3.1.13.1.3, however, cannot begin until the radiological monitoring plan is approved.

Activity 8.3.1.13.1.1 must be completed before the evaluation of near-site activities (Activity 8.3.1.13.2.1) can be completed. Likewise, Activity 8.3.1.13.1.2 must be completed before the evaluation of the impact of nuclear fuel cycle operations near the Yucca Mountain site and Las Vegas (Activity 8.3.1.13.2.2) can be completed

The activity numbers and titles corresponding to each timeline are shown on the left side of the following figure. The points on the timeline represent major events or important milestones associated with the activity. Solid lines represent study durations and dashed lines show interfaces. The data input and output at the interfaces are shown by circles.

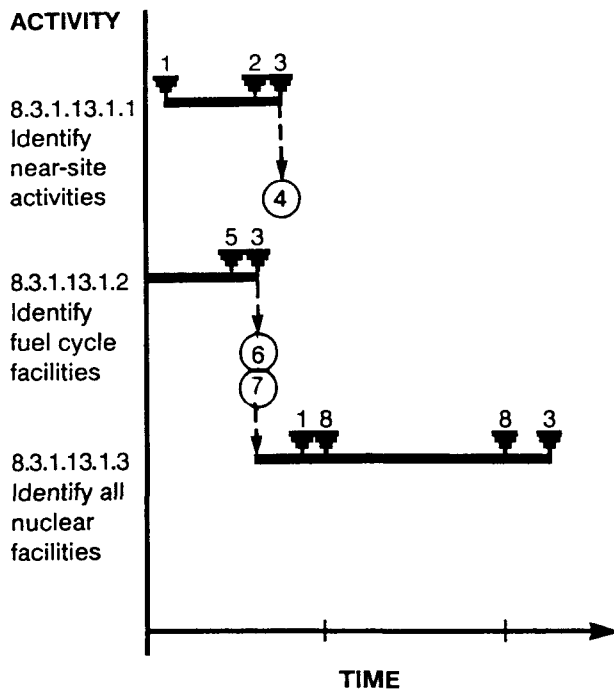

8311315-VA

CONSULTATION DRAFT

The points of the timelines and the data input and output at the interfaces are described in the following table:

<u>Point Number</u>	<u>Description</u>
1	Initiate data collection.
2	Milestone P329. Preliminary offsite impact study.
3	Complete data collection.
4	Final data available for completion of Activity 8.3.1.13.2.1 (evaluate near-site activities).
5	Conduct survey of nuclear fuel cycle activities.
6	Final draft available for completion of Activity 8.3.1.13.2.2 (impact of nuclear fuel cycle operations).
7	Radiological monitoring plan is issued (Milestone M897).
8	Issue annual radiological data summary report.

8.3.1.13.2 Investigation: Potential impacts on nearby installations and operations

Technical basis for obtaining the information

Link to the technical data chapters and applicable support documents

The preliminary data used in this activity are in Sections 3.4.1, 3.4.7, 3.5, 3.6.1, 3.6.3, 5.3, and 6.2.1.5 of the Yucca Mountain environmental assessment (DOE, 1986b). Information not currently available will be collected by the activities for Investigation 8.3.1.13.1. This investigation is addressed by activities described in the NNWSI Project transportation studies efforts, the Preliminary Site Characterization Radiological Monitoring Plan (SAIC, 1986b), and by the NNWSI Project Radiological Monitoring Plan (DOE, 1987d).

Parameters

The parameters for this investigation are as follows:

1. A list of all accidents initiated by offsite operations that must be considered in the repository safety analyses.
2. An assessment of the potential impacts of those events on the basis of data from Investigation 8.3.1.13.1.

CONSULTATION DRAFT

3. Estimates of potential exposures of the public to radiation and radioactive material from all nuclear fuel cycle activities in the area, which may affect compliance with 40 CFR 191.03 for the Yucca Mountain site.
4. Projected radioactive airborne concentrations for existing and projected conditions at the site.
5. Other factors contributing to onsite occupational or offsite exposure.
6. Data base to support evaluation of the adequacy of transportation access routes.

Purpose and objectives of investigation

The information collected from Investigation 8.3.1.13.1 will be used to conduct impact assessments as a result of accidents involving any nearby installations and operations. Those accidents include radiological and nonradiological events that may have an impact on site operations. The information collected will also be used to assess compliance with 40 CFR 191.03 and to resolve Issue 2.5 (Section 8.3.5.6) for routine releases. The results of these assessments will provide data and analyses for use in determining the preclosure radiological safety aspects of the site as outlined in the performance and designs issues of Key Issue 2 (preclosure radiological safety).

Technical rationale for investigation

The data on potential offsite accident initiators will be used to determine if further performance analyses (Issue 2.3, Section 8.3.5.5) are required. If so, the accident data will be used to assess preclosure system performance relative to the regulations cited in Key Issue 2.

The exposure from other nuclear fuel cycle operations covered by 40 CFR Part 190 are required to assess compliance with 40 CFR 191.03(a). The limits specified are the total for all nuclear fuel cycle operations.

The surrounding facilities will be evaluated to determine the effects they could have on potential repository operations and to determine the ability of the repository to complete its mission while in compliance with the regulations cited in Key Issue 2. The surrounding facilities could, under rare circumstances, force evacuation of the facility or limit the ability of the facility to detect and thus respond to abnormal events. This type of circumstance can thus act as an accident initiator (Issue 2.3, Section 8.3.5.5). In addition, any radiation exposure received by workers while at the site, independent of its sources, affects the ability of the facility to comply with applicable radiation standards for occupational exposure (Issue 2.2, Section 8.3.5.4).

The access route, which is part of the facility design, may affect the as low as is reasonably achievable (ALARA) evaluation of the facility because it may have a significant impact on exposure associated with transportation (DOE, 1986b) (Issues 2.1 and 2.2). This risk must be evaluated relative to

CONSULTATION DRAFT

the ALARA consideration in 10 CFR Part 20, applicable NRC guidance, DOE Order 5480.11 (DOE, 1985c), and DOE's ALARA Guidance (Kathren et al., 1980). The Nuclear Waste Policy Act (NWPA) of 1982 requires consideration of transportation impacts that may be significantly affected by the access routes selected for the Yucca Mountain repository (DOE, 1986b).

The following activities will evaluate all operations identified in Investigation 8.3.1.13.1 and assess their impact on compliance with Key Issue 2. These data will be used to provide the data base for evaluation of operations that could have an impact on Yucca Mountain repository operations and to support the resolution of Issues 2.1, 2.2, 2.3, and 2.5.

8.3.1.13.2.1 Activity: Evaluate near-site activities

Objectives

The objective of this activity is to review all commercial, DOE, DOD, and transportation operations within 8 km of the site; identify those operations that could act as accident initiators; and quantify their probability and magnitude. This activity will reduce the list of activities gathered in Activity 8.3.1.13.1.1 to those that could act as accident initiators, thus generating accident scenarios for analysis in the resolution of Issues 2.3 and 2.5.

Parameters

The parameters for this activity are

1. A list of all operations within 8 km of the Yucca Mountain site.
2. A description of the operations that have the potential to act as accident initiators for the site.
3. The probability and magnitude of events with potential to initiate accidents.

Description

Flight operations in the area are being reviewed and will be documented in a report to be issued. The list of all existing and projected operations in the area collected for Investigation 8.3.1.13.1 will be reviewed by experts to determine if any operations may adversely impact site activities. The primary considerations will include the following:

1. Could this operation lead to a breach of the Yucca Mountain containment barriers?
2. Could this operation require evacuation of the Yucca Mountain site or endanger site employees?
3. Could this operation cause the loss of offsite services (electrical, telephone, transportation access, etc.)?

CONSULTATION DRAFT

4. Could this operation cause a disruption of the flow of waste into the site?

Any such operation will be investigated and the probability and magnitude estimated on the basis of actual technical data on flight operations and the information from Activity 8.3.1.13.1.1. This data will then be used to support the analyses associated with Issues 2.3 and 2.5 and will be documented in a report on offsite impacts.

Methods and technical procedures

There are no methods and technical procedures associated with this activity.

8.3.1.13.2.2 Activity: Evaluation of the impact of nuclear fuel cycle operations near the Yucca Mountain site and Las Vegas

Objectives

The objective of this activity is to project the impact of all nuclear fuel cycle operations within 80 km of the Yucca Mountain site.

Parameters

The parameters of this activity are

1. A list of all nuclear fuel cycle operations within the specified area and the magnitude of their routine and projected accident releases estimated from Investigation 8.3.1.13.1.
2. Estimates of probabilities and magnitudes of any projected releases.

Description

All nuclear fuel cycle operations within an 80 km area will be reviewed. The routine yearly releases of radioactive material from all such facilities will be determined from safety documentation. In addition, the probability and magnitude of potential accidents at the facilities will be determined based on past technical reports and safety analyses documentation. The primary considerations will be to

1. Assess the magnitude of the routine releases of radioactive material from these facilities to determine their contribution to the nuclear fuel cycle facilities release limits (Issues 2.1 and 2.5 discussed in Section 8.3.5) specified in 40 CFR 191.03(a), if any.
2. Provide the basis for determination by the performance issues if the radioactive releases by these nuclear fuel cycle operations could obscure the detection of routine and accidental releases from a Yucca Mountain facility (Issues 2.1, 2.2, 2.3, and 2.5).

CONSULTATION DRAFT

3. Provide the basis for determination by the performance issues if this operation requires evacuation of the Yucca Mountain site (Issues 2.2 and 2.5) or exposes workers to significant levels of radiation (Issues 2.2, 2.3, and 2.5), which may endanger the workers or impact compliance with the exposure limits in 10 CFR Part 20.

All models and computer programs used in these evaluations will be consistent with those used in resolving Issues 2.1, 2.2, and 2.3.

Methods and technical procedures

There are no methods and technical procedures for this activity.

- 8.3.1.13.2.3 Activity: Evaluate the impact of all nuclear facilities not associated with the nuclear fuel cycle near the Yucca Mountain site

Objectives

The objective of this activity is to evaluate the data from Activity 8.3.1.13.1.3 to project airborne concentration, and the probability of such concentrations from operations within 80 km of the Yucca Mountain site contributing to the exposure of individuals in Las Vegas, Nevada.

The primary considerations in evaluating the results for this operation will be the same as items 2 and 3 under the objective for Activity 8.3.1.13.2.2.

Parameters

The parameters of this activity include the projected airborne radionuclide concentrations and the probabilities of such concentrations for the operations impacting the site.

Description

The routine yearly releases of radioactive material from all such facilities and the existing concentrations at the Yucca Mountain site will be determined. The probability and magnitude of potential accidents will be determined, including the probability and magnitude of release near the Yucca Mountain site. The mechanism for estimating impacts and probabilities will be a characterization of past impacts on the Yucca Mountain site.

This activity will include (1) the evaluation of resuspension of radionuclides from past operations at the NTS and the subsequent deposition at the site and (2) the extrapolation of NTS environmental data to Yucca Mountain using standard modeling techniques. All models and computer programs used in these evaluations will be consistent with those used in the resolution of Issues 2.1, 2.2, and 2.3.

CONSULTATION DRAFT

Methods and technical procedures

There are no methods and technical procedures for this activity.

8.3.1.13.2.4 Activity: Evaluate the impact of ground motion from nuclear testing activities at the NTS

This activity is addressed in the resolution of Investigation 8.3.1.17.3.

8.3.1.13.2.5 Activity: Evaluation of highway access routes to the Yucca Mountain site

Objectives

The objective of this activity is to identify all parameters that affect highway transport relative to the highway access route.

Parameters

The route-specific data for Nevada and adjacent states includes

1. Alternative routes.
2. Accident rates.
3. Usage level and types.
4. Physical route characteristics.
5. Risk factors.
6. Unidentified analytical data.

Description

This activity provides the data needed to evaluate highway access route adequacy using data from Issue 2.7. This data will be used to evaluate the adequacy of this access route relative to the NWPA requirements for minimizing transportation risk and ALARA requirements (Issues 2.1 and 2.5). These data will be appropriately documented. The analyses will be conducted in the same manner as similar analyses in the environmental assessment (DOE, 1986b), only in much greater detail and using the transport analyses capability currently being updated by the Office of Storage and Transportation Systems (RADTRAN, WASTES, Interline, and Highways).

Methods and technical procedures

There are no methods and technical procedures for this activity.

CONSULTATION DRAFT

8.3.1.13.2.6 Activity: Evaluation of rail access routes to the Yucca Mountain site

Objectives

The objective of this activity is to identify all parameters that affect rail transport relative to the highway access route.

Parameters

The route-specific data for Nevada and adjacent states includes

1. Parameters specified for Activity 8.3.1.13.2.5.
2. Rail access.
3. Carrier impact.

Description

This activity is the same as that described for Activity 8.3.1.13.2.5 except that it applies to the rail access route. This data will be documented in the access route characterization report.

Methods and technical procedures

There are no methods and technical procedures for this activity.

8.3.1.13.2.7 Application of results

The data from this investigation will be used in analyses conducted to ensure compliance with the radiological limits specified in Issues 2.2 through 2.5. It will be used to

1. Identify credible accident scenarios that must be analyzed to ensure facility compliance with regulations. This includes consideration of loss of offsite services and evacuations that could act as accident initiators (Information Needs 2.3.1 (credible accidents, Section 8.3.5.5.1) and 2.3.2 (projected releases from credible accidents, Section 8.3.5.5.2)).
2. Assess the radiological exposures from routine operations to determine the combined offsite exposures from all activities to nearby individuals required to be considered for the qualifying condition in the technical guideline on offsite installations (Issue 2.5).
3. Assess the radiological exposure of workers due to potential releases from other radiological facilities in the area to determine impacts on a Yucca Mountain facility (Information Need 2.2.1 (natural radiation environment, Section 8.3.5.4.1) and Issues 2.1 and 2.3).

CONSULTATION DRAFT

4. Assess the impact of offsite operations that could have radiological impacts that significantly affect facility feasibility (Issue 4.4, Section 8.3.2.5).

8.3.1.13.2.8 Schedule and milestones

This investigation addressing the impacts of offsite installations and operations contains six activities: 8.3.1.13.2.1 (evaluate near-site activities), 8.3.1.13.2.2 (evaluation of the impact of nuclear fuel cycle facilities near the Yucca Mountain site and Las Vegas), 8.3.1.13.2.3 (evaluate the impact of all nuclear facilities not associated with the nuclear fuel cycle near the Yucca Mountain site), 8.3.1.13.2.4 (evaluate the impact of ground motion from nuclear testing activities at the Nevada Test Site), 8.3.1.13.2.5 (evaluation of highway access routes to the Yucca Mountain site), and 8.3.1.13.2.6 (evaluation of rail access routes to the Yucca Mountain site). Activity 8.3.1.13.2.4 is addressed in Investigation 8.3.1.17.3.

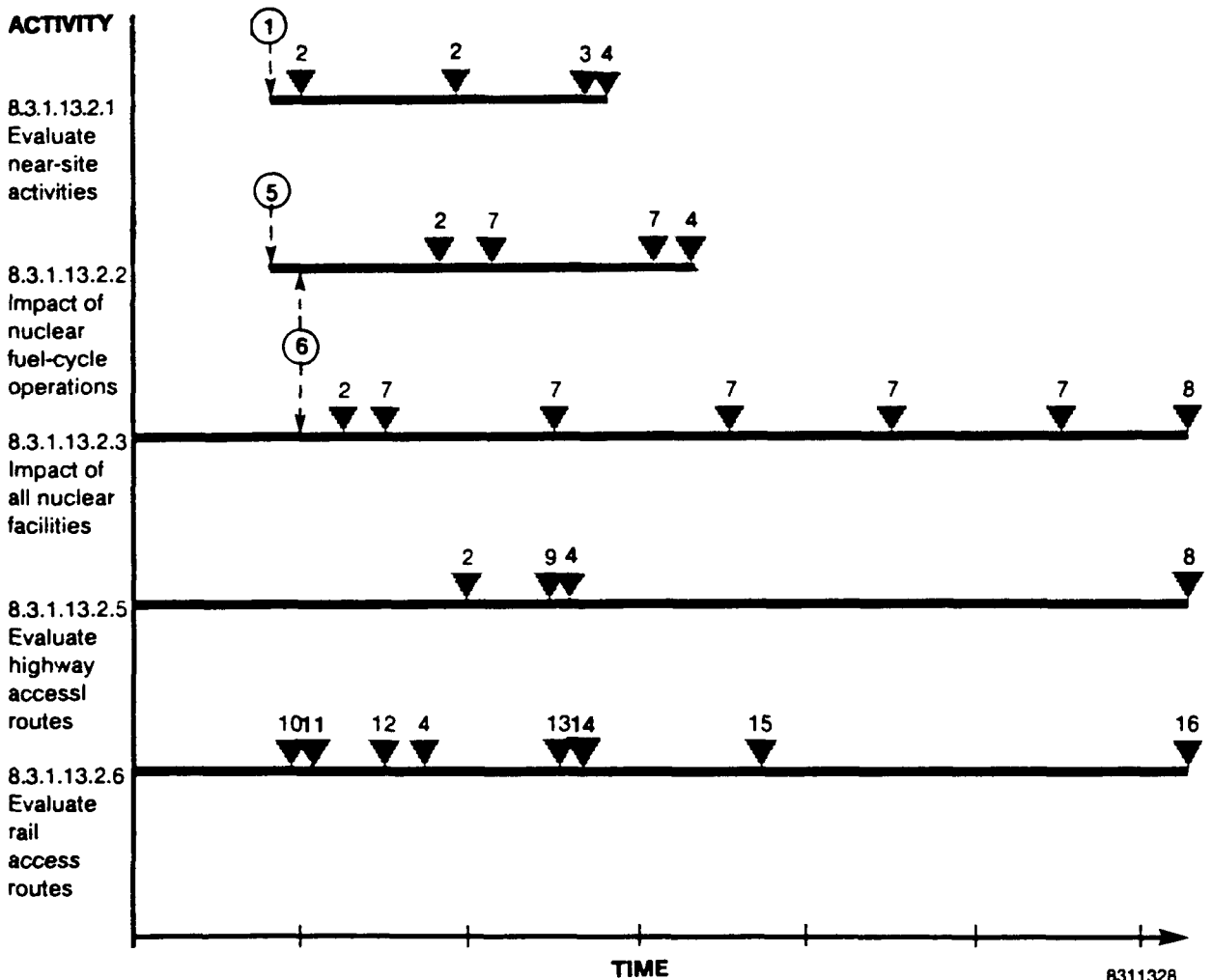

8311328

CONSULTATION DRAFT

The activity numbers and titles corresponding to each timeline are shown on the left side of the preceding figure. The points on the timeline represent major events or important milestones associated with the activity. Solid lines represent activity durations, and dashed lines show interfaces. The data input and output at the interfaces are shown by circles.

In the preceding figure, the schedule information for these activities is presented in the form of timelines. The timelines extend to the completion of data collection for the activity or to the issuance of the final products associated with the activities. Activities 8.3.1.13.2.3 and 8.3.1.13.2.6 are ongoing; the other activities are scheduled to begin within the first or second year of site characterization. Summary schedule information for this investigation can be found in Section 8.5.1.1.

Activities 8.3.1.13.2.2 and 8.3.1.13.2.3 cannot begin until the radiological monitoring plan is issued. However, limited radiological data collection is ongoing under the Preliminary Site Characterization Radiological Monitoring Plan (Activity 8.3.1.13.2.2). The identification of near-site activities (Activity 8.3.1.13.1.1) must be completed before Activity 8.3.1.13.2.2 can be completed. This investigation supports the resolution of Performance and Design Issues 2.1, 2.2, 2.3, and 2.5 (radiological safety issues) discussed in Section 8.3.5 and will be conducted in parallel with those activities.

The points on the timelines and the data input and output at the interfaces are described in the following table:

<u>Point number</u>	<u>Description</u>
1	Input available from Activity 8.3.1.13.1.1 (identification of near-site activities).
2	Initiate data collection.
3	Milestone P329. Complete offsite impact study.
4	Complete data collection.
5	Input available from Activity 8.3.1.13.1.2 (identification of nuclear fuel cycle facilities in the area).
6	Milestone M897. Issue radiological monitoring plan.
7	Issue annual radiological data summary report.
8	Issue final radiological monitoring data summary for environmental impact statement.
9	Issue data report for highway access route.
10	Complete preliminary scoping study for rail access spur options.

CONSULTATION DRAFT

<u>Point number</u>	<u>Description</u>
11	Complete assessment of U.S. Air Force aircraft impact frequency.
12	Issue report on the scenarios and potential radiological consequences associated with military aircraft crashes.
13	Issue report on alternative rail access spur screening.
14	Issue final report on U.S. Air Force overflight impacts.
15	Select rail access route to repository.
16	Milestone N338. Issue report on the characterization of the existing radiological environment.

Nuclear Waste Policy Act
(Section 113)

Section 8.3.1.14

Consultation Draft

SURFACE CHARACTERISTICS



Site Characterization Plan

***Yucca Mountain Site, Nevada Research
and Development Area, Nevada***

Volume V

January 1988

U.S. Department of Energy
Office of Civilian Radioactive Waste Management
Washington, DC 20585

CONSULTATION DRAFT

8.3.1.14 Overview of the surface characteristics program: Description of the surface characteristics required by the performance and design issues

Summary of performance and design requirements for surface characteristics information

The surface characteristics program reflects requirements from the DOE, the NRC, and the EPA that the surface facilities, including openings to the underground, must ensure public health and safety, are technically feasible, and have reasonable costs. This program investigates two areas pertinent to preclosure design and performance issues:

1. Topography (Investigation 8.3.1.14.1).
2. Soil and rock conditions (Investigation 8.3.1.14.2).

A logic diagram showing what design and performance issues and what characterization programs require surface characteristics information is presented in Figure 8.3.1.14-1. A more detailed interlinking of design and performance issue parameters with characterization program parameters is presented in Table 8.3.1.14-1. Table 8.3.1.14-1 is organized around column 4, characterization parameters, as the "key" column. The parameter listed in this column "feeds" characterization data to the design and performance parameters listed in column 3, performance or design parameters. Conversely, the resolution of the performance or design issues listed in column 3 requires data input from the characterization parameter specified in column 4.

The design- and performance-issue parameters in Table 8.3.1.14-1 are determined by the site surface system element (1.1.1) requirements described in Section 8.3.2 (Table 8.3.2.5-1). These design and performance parameters determine what characterization parameters will be needed. The characterization parameters with their expected ranges, confidence levels, and required activities are also presented in Table 8.3.1.14-1.

The issues and site programs related to the surface characteristics program, along with their SCP section number, are as follows (the relationships are discussed in the paragraphs following the list):

<u>Issue or program</u>	<u>Short title</u>
1.8	NRC siting criteria (Section 8.3.5.17)
1.9	Higher level findings--postclosure (Section 8.3.5.18)
1.11	Configuration of underground facilities--postclosure (Section 8.3.4.2)
4.4	Preclosure design and technical feasibility (Section 8.3.2.5)
4.5	Repository costs (Section 8.2.2.3.2.4)

8.3.1.14-2

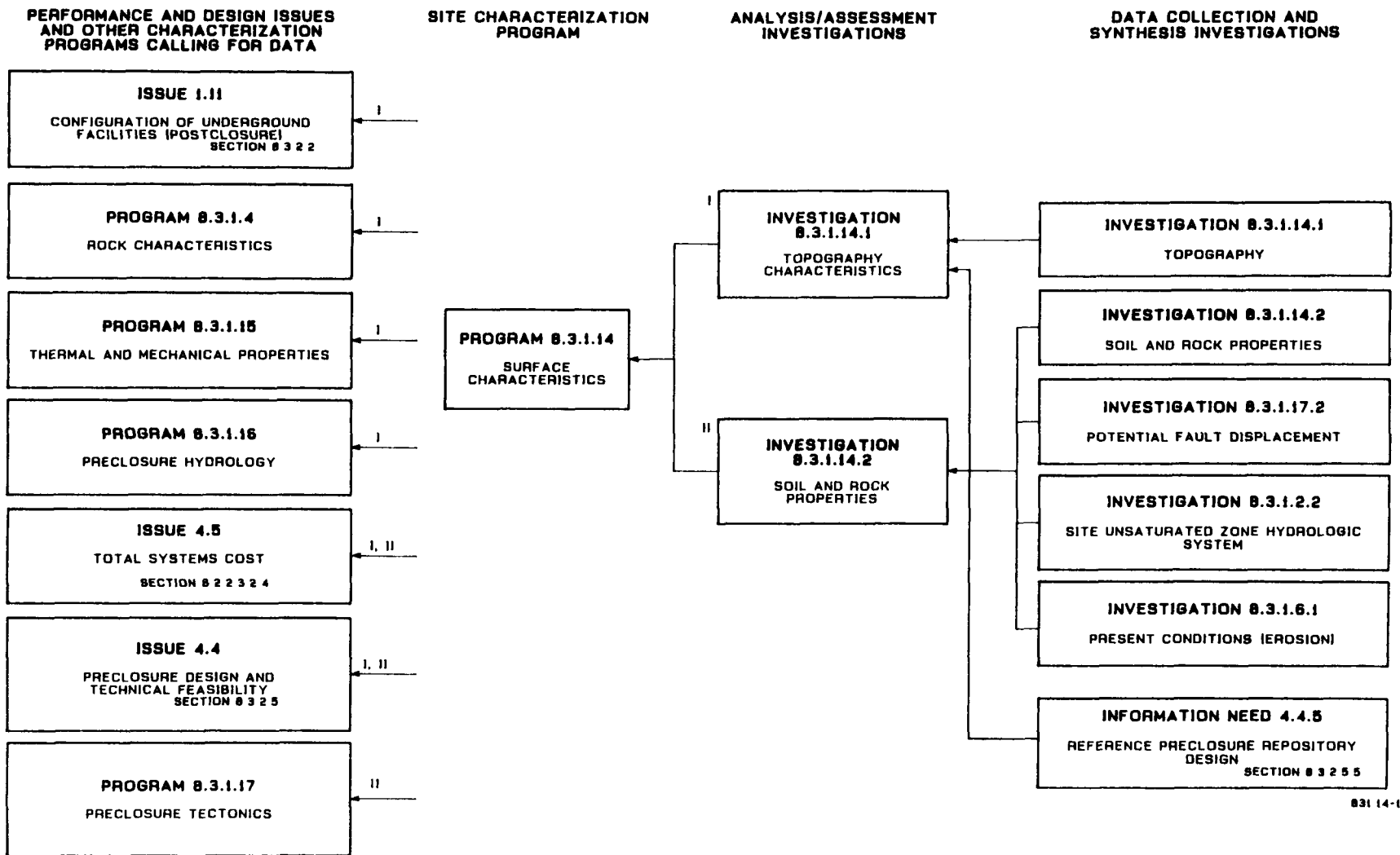

CONSULTATION DRAFT

831.14-1

Figure 8.3.1.14-1. Logic diagram for Program 8.3.1.14, surface characteristics. Roman numerals indicate data flow.

Table 8.3.1.14-1. Performance allocation for site surface characterization parameters and the corresponding performance or design parameters and issues they support^a
(page 1 of 12)

Issue or program	SCP section	Performance or design parameters ^b	Characterization parameters (key column)	Current estimate	Current confidence	Needed confidence	Study or activity providing data	
GEOMETRICAL PARAMETERS								
1.11	8.3.2.2.1	Surface topography at facility locations (1-m contour interval)	Surface topography at facility locations (1-m contour interval)	20-ft contour interval topographic map (see Figure 4-3 of the SCP-CDR (SNL, 1987))	Medium	Medium	No further studies are planned. Topographical measurements have been made and topographic maps are forthcoming.	
4.4	8.3.2.2.3							
	8.3.2.5.1							
	8.3.2.5.5							
	8.3.2.5.7							
8.3.1.4	8.3.1.4.3							
8.3.1.15	8.3.1.15.3							
8.3.1.16	8.3.1.16.1							
4.4	8.3.2.5.1	Allowable foundation bearing capacity in soil						
	8.3.2.5.5							
	8.3.2.5.7							
								Allowable foundation bearing capacity in rock
								Active and passive soil pressures on a wall
								Active and passive rock pressures on a wall
		Factor of safety of slope (soil)						
		Factor of safety of slope (rock)						
4.4	8.3.2.5.1	Surface topography of access routes (2-m contour intervals)	Surface topography of access routes (2-m contour intervals)	20-ft contour interval topographic map (see Figures 4-2 and 4-3 of the SCP-CDR (SNL, 1987))	Medium	Medium	No further studies are planned. Topographical measurements have been made and topographic maps are forthcoming.	
	8.3.2.5.5							
	8.3.2.5.7							
8.3.1.16	8.3.1.16.1							
4.4	8.3.2.5.1	Factor of safety of slope (soil)						
	8.3.2.5.5							
	8.3.2.5.7							
		Factor of safety of slope (rock)						

8.3.1.14-3

CONSULTATION DRAFT

Table 8.3.1.14-1. Performance allocation for site surface characterization parameters and the corresponding performance or design parameters and issues they support^a
(page 2 of 12)

Issue or program	SCP section	Performance or design parameters ^b	Characterization parameters (key column)	Current estimate	Current confidence	Needed confidence	Study or activity providing data
SOIL PARAMETERS							
		Allowable foundation bearing capacity in soil	Alluvial stratigraphy	General stratigraphic description. Top 0.3 to 0.7 m is loose	Low	Medium	8.3.1.14.2.1.1, 8.3.1.14.2.1.2, 8.3.1.14.2.1.3, 8.3.1.14.3.3
		Active and passive soil pressure on a wall	Layering Thickness Geometry	fine-grained sandy soil overlying approximately 2 m of material that is partly to wholly cemented with calcite (caliche). Below the caliche layer is an 11 to 50 m thick layer of dense sandy gravel alluvial material which overlies the ash-flow tuff bedrock (Section 6.1.2.1.2)			
4.4	8.3.2.5.1	Factor of safety of slope (soil)					
	8.3.2.5.5	Soil-structure interaction for foundation ^c					
	8.3.2.5.7						
8.3.1.17	8.3.1.17.3	Soil-structure interaction for retaining wall ^c					
4.4	8.3.2.5.1	Magnitude of time dependent settlement in soils below earthfills ^d					
	8.3.2.5.5						
	8.3.2.5.7						
		Magnitude of swell in sub-grade soils					
		Magnitude of soil collapse ^d					
		Soil liquefaction potential ^d					
		Identification of any fault within 100 m of facilities important to safety (FITS) with greater than 1 chance in 100 of producing more than 5 cm of surface displacement in 100 yr	Alluvial faulting (the study for this characterization parameter is developed in Section 8.3.1.17.4.2 (preclosure tectonics)) location orientation	See Section 8.3.1.17.4.2 in preclosure tectonics	Low	High	See Study 8.3.1.17.4.2, (location and recency of faulting near prospective surface facilities)

8.3.1.14-4

CONSULTATION DRAFT

Table 8.3.1.14-1. Performance allocation for site surface characterization parameters and the corresponding performance or design parameters and issues they support^a
(page 3 of 12)

Issue or program	SCP section	Performance or design parameters ^b	Characterization parameters (key column)	Current estimate	Current confidence	Needed confidence	Study or activity providing data
		Allowable foundation bearing capacity in soil	Soil classification vs. depth Soil gradation ^d Atterberg limits ^d	GP-GM ^e From preliminary investigations, no cohesive soils have been found	Low Low	Medium Medium	8.3.1.14.2.2.1
		Active and passive soil pressure on a wall					
		Factor of safety of slope (soil)					
		Soil-structure interaction for foundation ^b					
		Soil-structure interaction for retaining wall ^b					
		Magnitude of time dependent settlement ^d in soils below earthfills ^d					
		Magnitude of swell in sub-grade soils ^d					
		Magnitude of soil collapse ^d					
		Soil liquefaction potential ^d					
		Allowable foundation bearing capacity in soil	Physical properties vs. depth				8.3.1.14.2.2.1, 8.3.1.14.2.3.1
		Active and passive soil pressure on a wall	In situ density Relative density Moisture content Percent saturation Specific gravity	101-112 pcf Not available 7.2% 47.3% 2.43	Low Low Low Low Low	Medium Medium Medium Medium Medium	
		Factor of safety of slope (soil)					
		Soil-structure interaction for foundation ^c					

8.3.1.14-5

CONSULTATION DRAFT

Table 8.3.1.14-1. Performance allocation for site surface characterization parameters and the corresponding performance or design parameters and issues they support^a
(page 4 of 12)

Issue or program	SCP section	Performance or design parameters ^b	Characterization parameters (key column)	Current estimate	Current confidence	Needed confidence	Study or activity providing data
		Soil-structure interaction for retaining wall ^c					
		Magnitude of time dependent settlement in soils below earthfills ^d					
		Magnitude of swell in sub-grade soils ^d					
		Magnitude of soil collapse ^d					
		Soil liquefaction potential ^d					
		Allowable foundation bearing capacity in soil ^e	Compaction characteristics				
		Active and passive soil pressure on a wall	Compaction curves for potential fill material including maximum dry density (γ_d) and optimum water content	γ_d (max) \approx 108-114 pcf Optimum water content \approx 12-15%	Low Low	Medium Medium	8.3.1.14.2.2.1
		Magnitude of soil collapse ^d					
4.4	8.3.2.5.1 8.3.2.5.5 8.3.2.5.7	Allowable foundation bearing capacity in soil	Mechanical and dynamic properties vs. depth for undisturbed and recompacted soils	10,000-20,000 psi (static) (Ho et al., 1986)	Low	Medium	8.3.1.14.2.2.2, 8.3.1.14.3.2., 8.3.1.14.2.3.3
8.3.1.17	8.3.1.17.3	Soil-structure interaction for foundation ^c	Young's modulus (static and dynamic) Poisson's ratio	192,000 psi (dynamic calculated from V_p) 0.3-0.35 (static) (Ho et al., 1986) 0.286 (dynamic) (Neal, 1986)	Low	Medium	8.3.1.14.2.2.2, 8.3.1.14.2.3.3
		Soil-structure interaction for retaining wall ^c					
		Soil liquefaction potential ^d	Compressive wave velocity (V_p) and shear wave velocity (V_s) (these parameters will be	$V_p \approx$ 3,300 ft/sec (Neal, 1986) $V_s \approx$ 1,800 ft/sec (Neal, 1986)	Medium	High	8.3.1.14.2.3.3
		Soil-structure interaction for foundation ^c					

8.3.1.14-6

CONSULTATION DRAFT

Table 8.3.1.14-1. Performance allocation for site surface characterization parameters and the corresponding performance or design parameters and issues they support^a
(page 5 of 12)

Issue or program	SCP section	Performance or design parameters ^b	Characterization parameters (key column)	Current estimate	Current confidence	Needed confidence	Study or activity providing data
		Soil-structure interaction for retaining wall ^c	used to calculate the dynamic elastic characterization parameters: Young's modulus, shear modulus, and Poisson's ratio).				
		Soil liquefaction potential ^d					
			Shear modulus (static and dynamic)	3,700-7,700 psi (static-calculated) 74,100 psi (dynamic-calculated from Vs)	Low	Medium	8.3.1.14.2.3.3
			Damping	Not available	Low	Medium	8.3.1.14.2.3.3
4.4	8.3.2.5.1 8.3.2.5.5 8.3.2.5.7	Allowable foundation bearing capacity in soil	Mohr-Coulomb strength parameters in terms of cohesion (c) and angle of friction (ϕ)	c \approx 500 psf (cemented) $\phi \approx 33^\circ$ to 37°	Low	High	8.3.1.14.2.2.2
		Active and passive soil pressure on a wall					
		Factor of safety of slope (soil)					
		Soil-structure interaction for foundation ^c					
		Soil-structure interaction for retaining wall ^c					
		Allowable foundation bearing capacity in soil	Plate load bearing pressure vs. settlement	Not available	Low	Medium	8.3.1.14.2.3.2

CONTINGENT SOIL PARAMETERS

The following characterization parameters are contingent parameters (see footnote d)

8.3.1.14-7

CONSULTATION DRAFT

Table 8.3.1.14-1. Performance allocation for site surface characterization parameters and the corresponding performance or design parameters and issues they support^a
(page 6 of 12)

Issue or program	SCP section	Performance or design parameters ^b	Characterization parameters (key column)	Current estimate	Current confidence	Needed confidence	Study or activity providing data
4 4	8 3 2 5 1	Soil structure interaction for foundation ^c	Other strength parameters such as Drucker-Prager ^d , etc (if required)	Not available	Low	Medium	8 3 1 14 2 2 2
8 3 1 17	8 3 2 5 5 8 3 2 5 7 8 3 1 17 3	Soil-structure interaction for retaining wall ^c	Bulk modulus and constrained modulus	Not available	Low	Medium	8 3 1 14 2 2 2
		Soil liquefaction potential ^d	Strength and stress-deformation characteristics under dynamic load conditions evaluated as a function of stress rate, confinement stress, initial static stress level, magnitude of pulsating stress, number of stress cycles, and frequency of loading ^d	Not available	Low	Medium	8 3 1 14 2 2 2
			Dynamic shear modulus as a function of strain and confinement stress ^d	Not available	Low	High	8 3 1 14 2 2 2, 8 3 1 14 2 3 3
			Damping as a function of strain ^d	Not available	Low	High	8 3 1 14 2 2 2, 8 3 1 14 2 3 3
			Shear wave velocities as a function of strain ^d	Not available	Low	High	8 3 1 14 2 2 2, 8 3 1 14 2 3 3
			Deformation modulus in terms of stress-strain characteristics and confinement stress conditions ^d	Not available	Low	High	8 3 1 14 2 2 2
4 4	8 3 2 5 1 8 3 2 5 5 8 3 2 5 7	Soil liquefaction potential ^d	Liquefaction parameters cyclic shearing stress ratio, cyclic deformation, and pore-pressure response (this information	Not available	Low	Medium	8 3 1 14 2 2 2

8.3.1.14-8

CONSULTATION DRAFT

Table 8.3.1.14-1. Performance allocation for site surface characterization parameters and the corresponding performance or design parameters and issues they support^a
(page 7 of 12)

Issue or program	SCP section	Performance or design parameters ^b	Characterization parameters (key column)	Current estimate	Current confidence	Needed confidence	Study or activity providing data
			will not be needed if there are no perched water bodies near the _d ground surface)				
		Allowable foundation bearing capacity in soil	Modulus of subgrade reaction from plate load test (static and dynamic) ^d	200-300 pci	Low	Medium	8.3.1.14.2.2.2
		Soil-structure interaction for foundation ^c					
		Soil-structure interaction for retaining wall ^c					
		Allowable foundation bearing capacity in soil	Compression and swell index (for saturated clayey soils if they are encountered)	Not available	Low	Medium	8.3.1.14.2.3.2
		Magnitude and rate of time dependent settlement below earthfills ^d					
		Magnitude of swell in sub _d grade soils below roads	Coefficient of consolidation (for saturated clayey soils if they are encountered) ^d	Not available	Low	Medium	8.3.14.2.2.2
		Allowable foundation bearing capacity in soil	Collapse potential (for relative dry _d low density soils) ^d	Not available	Low	Medium	8.3.1.14.2.2.2
		Magnitude of soil collapse below surface facilities (foundations, earthfills, and roads) due to saturation and/or loading					
----- OTHER SOIL PARAMETERS							
		Favorable hydraulic induced soil erosion characteristics	Erosion potential	<13 m/100 yr of scour around bridge piers <5 m/100 yr of bed erosion <1 m/100 yr of sheet erosion	Low	Medium	8.3.1.14.2.2.2

8.3.1.14-9

CONSULTATION DRAFT

Table 8.3.1.14-1. Performance allocation for site surface characterization parameters and the corresponding performance or design parameters and issues they support^a
(page 8 of 12)

Issue or program	SCP section	Performance or design parameters ^b	Characterization parameters (key column)	Current estimate	Current confidence	Needed confidence	Study or activity providing data
		Favorable infiltration/runoff ratio	Infiltration/runoff ratio	See Section 8.3.1.12 (meteorology) and 8.3.1.2 (geohydrology)	Low	Medium to high	8.3.1.6.1.1.2, 8.3.1.6.1.1.3

ROCK PARAMETERS							
4.4	8.3.2.5.1	Allowable foundation bearing capacity in rock	Rock stratigraphy	See Figure 6-6 in the SCP and Figures 5 and 7 in Neal (1986)	Low	Medium	See Section 8.3.1.12 (meteorology) and 8.3.1.2 (geohydrology)
	8.3.2.5.5	Active and passive rock pressure on a wall	Rock type				
8.3.1.17	8.3.1.17.3	Factor of safety of slope (rock)	Layering				
		Rock-structure interaction for foundation ^c	Thickness				
		Rock-structure interaction for retaining wall ^c	Geometry				
4.4	8.3.2.5.1	Allowable foundation bearing capacity in rock	Rock structure	Not available	Low	High	8.3.1.14.2.1.1, 8.3.1.14.2.1.2, 8.3.1.14.2.1.3, 8.3.1.14.2.3.3
	8.3.2.5.5	Active and passive rock pressure on a wall	Quantitative description of faults				
	8.3.2.5.7	Factor of safety of slope (rock)	Location				
			Orientation				
			Aperture				
			Type of infilling				
			Moisture and/or seepage conditions				
			Waviness and roughness				
			Quantitative description of joints	Not available			
			Number of joint sets				
			Spacing of joints for each set				
			Orientation of each joint set				
			Type of infilling if any				

8.3.1.14-10

CONSULTATION DRAFT

Table 8.3.1.14-1. Performance allocation for site surface characterization parameters and the corresponding performance or design parameters and issues they support^a
(page 9 of 12)

Issue or program	SCP section	Performance or design parameters ^b	Characterization parameters (key column)	Current estimate	Current confidence	Needed confidence	Study or activity providing data
			Moisture and/or seepage conditions Waviness and roughness Persistence Drill core (total core recovery, discontinuity, frequency, and rock quality designation (RQD))				
		Allowable foundation bearing capacity in rock Active and passive rock pressure on a wall Rock-structure interaction for foundation ^c Rock-structure interaction for retaining wall ^c	Rock mass classification ^f Rock mass rating (RMR) ^f Tunneling quality index (Q) ^f	Not available	Low	Medium	8.3.1.14.2.1.2, 8.3.1.14.2.1.3, 8.3.1.14.2.3.1
		Allowable foundation bearing capacity in rock Active and passive rock pressure on a wall Factor of safety of slope (rock) Rock-structure interaction for foundation ^c Rock-structure interaction for retaining wall ^c	Physical properties vs. depth Density (dry) Percent saturation Porosity Specific gravity	2.23 gm/cc or 139 lb/ft 67% ± 23% 11% ± 4% 2.51 ± 0.04	Low Low Low Low	Medium Medium Medium Medium	8.3.1.14.2.3.1
		Allowable foundation bearing capacity in rock Rock-structure interaction for foundation ^c	Mechanical and dynamic properties Plate load bearing pressure vs. settlement	Not available	Low	Medium	8.3.1.14.2.2.1

8.3.1.14-11

CONSULTATION DRAFT

Table 8.3.1.14-1. Performance allocation for site surface characterization parameters and the corresponding performance or design parameters and issues they support^a
(page 10 of 12)

Issue or program	SCP section	Performance or design parameters ^b	Characterization parameters (key column)	Current estimate	Current confidence	Needed confidence	Study or activity providing data
		Magnitude of soil collapse ^d below surface facilities ^d					
		Allowable foundation bearing capacity in rock	Peak and residual failure envelopes derived from uniaxial and triaxial compression tests	c (peak) = 26.0 +10.13 MPa (range)	Low	High	8.3.1.14.2.3.2
		Factor of safety of slope (rock)		ϕ (peak) = 44.7° +0.20° (range)			
		Rock-structure interaction for foundation ^c		Tensile strength = 9.3 MPa			
		Rock-structure interaction for retaining wall ^c		Unconfined compressive strength = 120 ± 82 MPa (range)			
		Allowable foundation bearing capacity in rock	Discontinuity shear strength in terms of c and ϕ	c = 0.1 MPa ± 0.1 (range)	Medium	High	8.3.1.14.2.2.2
		Active and passive rock pressure on a wall		ϕ = 28.4° (range: 11.3° - 38.7°)			
		Factor of safety of slope (rock)					
4.4	8.3.2.5.1	Allowable foundation bearing capacity in rock	Young's modulus (static and dynamic)	20.0 GPa ± 5.55 (range)	Low	Medium	8.3.1.14.2.2.2
	8.3.2.5.5			- static rock mass (SCP, Chapter 6)			
	8.3.2.5.7			2.94 GPa (calculated from in situ Vp)			
8.3.1.17	8.3.1.17.3	Rock-structure interaction for foundation ^c	Poisson's ratio	0.24 (laboratory-static) (SCP, Chapter 6)	Low	Medium	8.3.1.14.2.2.2, 8.3.1.14.2.3.2, 8.3.1.14.2.3.3
		Rock-structure interaction for retaining wall ^c		0.319 (in situ calculated from Vp and Vs) (Neal, 1986)			
		Rock-structure interaction for foundation ^c	Shear modulus (static and dynamic)	8.1 GPa ± 2.2 (range)	Low	Medium	8.3.1.14.2.2.2, 8.3.1.14.2.3.3
		Rock-structure interaction for retaining wall ^c		- static rock mass 1.1 GPa (calculated from in situ Vs)			
		Rock-structure interaction for foundation ^c	Compressive wave velocities vs. depth	Vp ≈ 7,500 - 9,000 ft/sec (laboratory) (Neal, 1986)	Low	High	8.3.1.14.2.2.2, 8.3.1.14.2.3.3
		Rock-structure interaction for retaining wall ^c		Vp ≈ 4,500 ft/sec (in situ) (Neal, 1986)			

8.3.1.14-12

CONSULTATION DRAFT

Table 8.3.1.14-1. Performance allocation for site surface characterization parameters and the corresponding performance or design parameters and issues they support^a
(page 11 of 12)

Issue or program	SCP section	Performance or design parameters ^b	Characterization parameters (key column)	Current estimate	Current confidence	Needed confidence	Study or activity providing data
			Shear wave velocities vs. depth (the compressive and shear wave velocities will be used to calculate the dynamic elastic characterization parameters: Young's modulus, shear modulus, and Poisson's ratio)	V _s ≈ 4,300 - 5,700 ft/sec (laboratory-calculated) V _s ≈ 2,320 ft/sec (in situ-calculated)	Low	High	8.3.1.14.2.2.2, 8.3.1.14.2.3.3
			Damping vs. depth	Not available	Low	High	8.3.1.14.2.2.2, 8.3.1.14.2.3.3

CONTINGENT ROCK PARAMETERS							
The following characterization parameters are contingent parameters (see footnote(d))							
		Rock-structure interaction for foundation ^c	Shear wave velocities as a function of strain ^d	Not available	Low	High	8.3.1.14.2.2.2, 8.3.1.14.2.3.3
		Rock-structure interaction for retaining wall ^c	Dynamic shear modulus as a function of strain ^d	Not available	Low	High	8.3.1.14.2.2.2, 8.3.14.4.2.3.3
			Damping as a function of strain ^d	Not available	Low	High	8.3.1.14.2.2.2, 8.3.1.14.2.3.3

^aThis table is organized around column 4, characterization parameters, as the "key" column. The parameter listed in this column "feeds" characterization data to the design and performance parameters listed in column 3, performance or design parameters. Conversely, the resolution of the performance or design issues listed in column 3 requires data input from the characterization parameter specified in column 4 (key column).

^bSee Table 8.3.2.5-1 for complete description of performance and design parameter.

^cIf the alluvium or rock adjacent to the foundation has shear velocities greater than 3,500 ft/sec, then a soil structure interaction analysis will probably not be necessary.

8.3.1.14-13

CONSULTATION DRAFT

Table 8.3.1.14-1. Performance allocation for site surface characterization parameters and the corresponding performance or design parameters and issues they support^a
(page 12 of 12)

Footnotes (continued)

^dThe need for these design and performance parameters or characterization parameters are contingent on the soil and rock conditions encountered, function or design requirements of the surface facilities, types of foundations selected, and the sophistication or type of analyses used in the design or performance studies. However, based on the sites preliminary surface soil and rock data and the type of foundations which are recommended in the SCP-CDR (SNL, 1987), the parameters are currently not needed.

^eGP = poorly graded gravel; GM = silty gravel.

^fRMR = rock mass rating from CSIR (South African Council for Scientific and Industrial Research) Geomechanics Classification;
Q = NGI (Norwegian Geotechnical Institute) tunneling quality index.

CONSULTATION DRAFT

<u>Issue or program</u>	<u>Short title</u>
8.3.1.4	Rock characteristics
8.3.1.12	Meteorology program
8.3.1.15	Thermal and mechanical properties program
8.3.1.16	Preclosure hydrology
8.3.1.17	Preclosure tectonics

Surface characteristic information such as topographic contours will be required for locating and designing repository surface facilities (Issue 4.4), establishing repository costs (Issue 4.5, program to be determined after scoping hearings for the environmental impact statement), and determining probable flood levels at potential surface facility locations (Program 8.3.1.16). Topographic contour maps are necessary for locating shaft and ramp entrances above potential flood levels and for locating sensitive structures such as waste handling facilities.

Surface topographic characteristics will also be required for certain underground design and performance studies. Topographic contour maps will be used to determine the usable repository horizon area while maintaining the required amount of overburden (Issues 1.8 and 1.9). The topographic data from Investigation 8.3.1.14.1 will actually be provided to Issue 1.11 to determine if the repository has an adequate amount of overburden to resolve Issues 1.8 and 1.9. Also, in situ stresses will be influenced, in part, by local topography (Programs 8.3.1.4 and 8.3.1.15).

The surface characteristics of the alluvial soil and rock at or near the surface impact the location and design of the surface facilities (Issue 4.4) and their costs (Issue 4.5). This is especially applicable to sensitive structures, such as the waste-handling facilities, which may experience earthquake loading (Section 8.3.1.17). The soil and rock conditions of the site for static-loading conditions will influence the selection of the surface facility location in addition to its foundation design.

The performance issue under Key Issue 4 specifies that the higher level findings required by 10 CFR Part 960 be supported for (1) the qualifying condition on the preclosure system guideline for ease and cost of construction on the basis of reasonably available technology and (2) the qualifying condition on the technical guideline for surface characteristics. Section 8.3.5.7 (Issue 4.1) discusses the higher level findings.

Approach to satisfy performance and design requirements

Surface-characterization information must be obtained and evaluated to determine whether it will support the preclosure higher level findings for preclosure radiological safety and the ease and cost of siting, construction, operation, and closure of the repository. The approach to determining

CONSULTATION DRAFT

whether the information about surface characteristics and conditions is adequate to resolve the performance and design issues is an iterative process. Close collaboration between engineering and geotechnical participants is needed to allow timely development of the repository design.

The major elements defining the surface characteristics include topography and soil and bedrock properties. Site surface characteristics data will be used to design surface structures and their foundations for buildings, shaft and ramp portals, roads, drainage systems, and flood control structures. These designs will also consider dynamic loading conditions caused by earthquakes and man-induced explosions.

The information required for any of the surface characteristics investigations will be initiated by the site surface system element 1.1.1 (site surface) requirements described in Section 8.3.2.5. To satisfy these requirements, the appropriate design and performance parameters must be obtained. A listing of these design and performance parameters and their corresponding characterization program parameters was previously presented in Table 8.3.1.14-1. To determine these characterization program parameters, studies and activities have been developed to provide the appropriate data. A list of characterization parameters and their corresponding studies and activities is also presented in Table 8.3.1.14-1.

A summary of the information required for the soil and rock property investigation (8.3.1.14.2) is provided in the logic diagram in Figure 8.3.1.14-2. This figure illustrates the information required by the soil and rock investigation and what studies and activities are needed to provide this information. A similar logic diagram was not developed for the other investigation in Program 8.3.1.14. The topography investigation (8.3.1.14.1) needs no further data acquisition activities since adequate contour maps have already been developed.

The site requirements discussed for this program and its associated investigations will be in conformance with applicable local, State of Nevada, and Federal codes and standards referring to natural hazard and foundation stability, such as those requirements specified in DOE Order 6430 (DOE, 1983a).

Interrelationships of surface characteristics investigations

There are no interrelationships between the investigations within the surface characteristics program. The investigations within this program only have interrelationships with issues and programs outside this program. The connections between the surface characteristics program and the performance and design issues or other characterization programs calling for data from this program have already been presented in Figure 8.3.1.14-1. This same figure also shows what investigations or information needs supply data to this program.

To provide a more detailed description of these interrelationships, two additional tables have been prepared. The investigations and information needs that require parameters from this program are provided in Table 8.3.1.14-2. This table also indicates why the data are needed and recommends general types of studies to obtain the data. Table 8.3.1.14-3 describes the

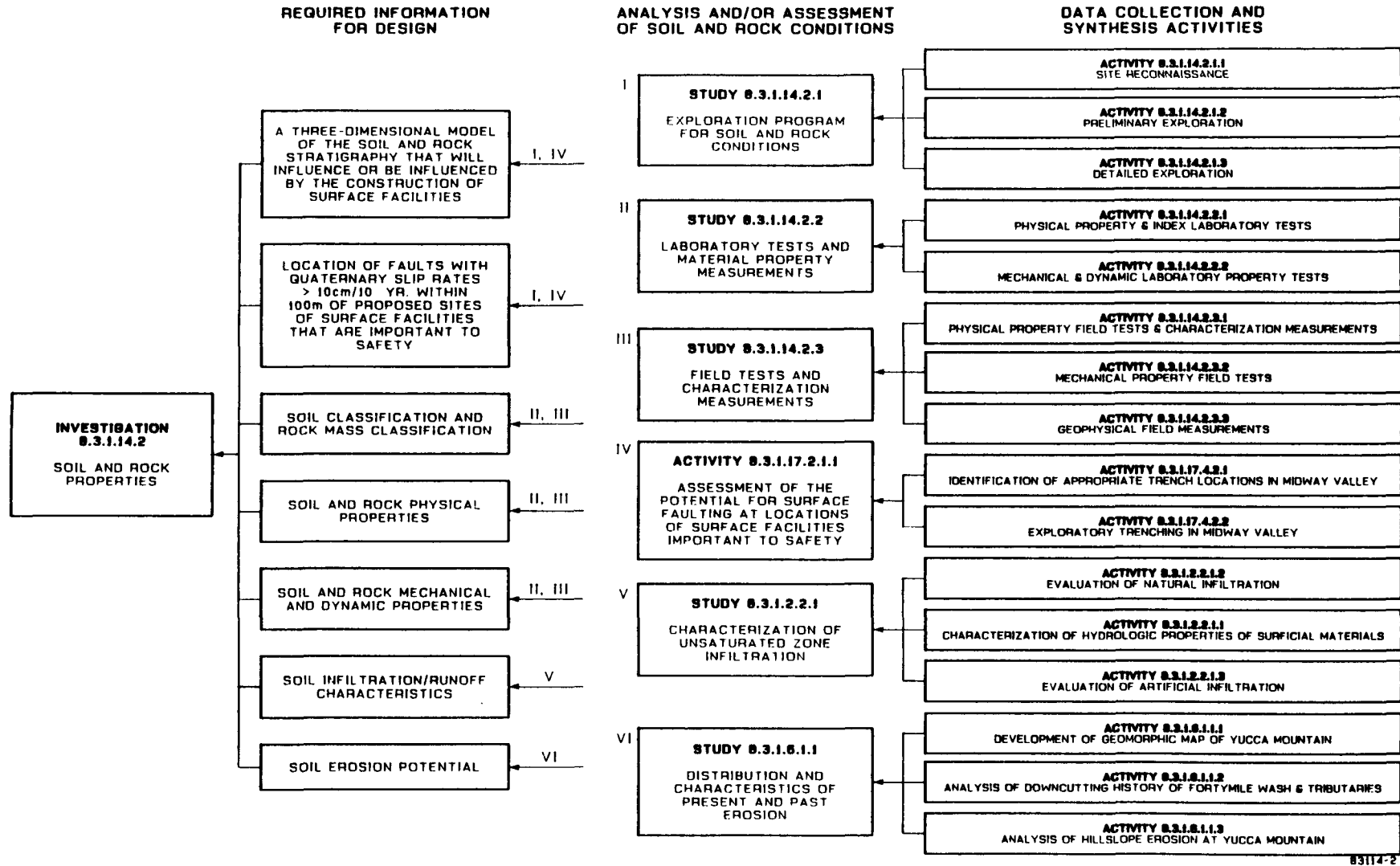

Figure 8.3.1.14-2. Logic diagram for Investigation 8.3.1.14.2, soil and rock properties.

Table 8.3.1.14-2. Investigations and information needs that require parameters from the surface characteristics program (page 1 of 6)

Issue, investigation, or information need calling for data	Parameter	Why data needed	Type of study or analysis needed to develop parameter
INVESTIGATION 8.3.1.14.1 (TOPOGRAPHY)			
2.3.1 Credible repository accidents (Section 8.3.5.5.1)	Topographic contour maps	Determine if accidents from potential slope instabilities and flooding are credible	Topographic survey of the site
2.7.1 Radiological protection (Section 8.3.2.3.1)	Topographic contour maps	Evaluate the potential for slope instabilities and flooding	Topographic survey of site
4.1 Determine if site meets qualifying conditions of the technical guidelines (Section 8.3.5.7)	Topographic contour maps	Determine ease and cost of siting, construction, operation, and closure	Topographic survey of the site
4.2.1 Site performance information needed for design (Section 8.3.2.4.1)	Topographic contour maps	Evaluate the potential for slope instabilities and flooding that may be a hazard to personnel	Topographic survey of the site

8.3.1.14-18

CONSULTATION DRAFT

Table 8.3.1.14-2. Investigations and information needs that require parameters from the surface characteristics program (page 2 of 6)

Issue, investigation, or information need calling for data	Parameter	Why data needed	Type of study or analysis needed to develop parameter
INVESTIGATION 8.3.1.14.1 (TOPOGRAPHY) (continued)			
4.4.1 Site and performance assessment information needed for design (Section 8.3.2.5.1)	Topographic contour maps	Evaluate feasibility and cost effective technologies for construction and operation on topography of proposed site	Topographic survey of the site
4.5 Total system costs ^a (Section 8.2.2.3.2.4)	Topographic contour maps	Evaluate cost of repository on topography of proposed site	Topographic survey of the site
8.3.1.16.1 Flood recurrence intervals and levels at surface facility locations	Topographic contour maps	Flood magnitudes and levels will be used in performance assessment and surface facility design studies	Topographic survey of the site
1.11 Site characterization information needed for design to determine if the repository configurations satisfy Issues 1.9 (Section 8.3.5.18) and 1.8 (Section 8.3.5.17).	Isopach maps of overburden thickness above repository horizon	Determine if the favorable 300-m overburden depth is satisfied in 10 CFR 60.122(b)(5). Determine if site is disqualified based on minimum 200-m overburden depth in 10 CFR 960.4-2-5(d)	Topographic survey of the site

8.3.1.14-19

CONSULTATION DRAFT

Table 8.3.1.14-2. Investigations and information needs that require parameters from the surface characteristics program (page 3 of 6)

Issue, investigation, or information need calling for data	Parameter	Why data needed	Type of study or analysis needed to develop parameter
INVESTIGATION 8.3.1.14.1 (TOPOGRAPHY) (continued)			
8.3.1.15.2 and 8.3.1.4.3 Spatial distribution of ambient stress conditions and three-dimensional rock characteristics model	Topographic contour maps and ground surface elevation cross sections	Determine in situ stress at depth considering surface topography variations	Topographic survey of the site
8.3.1.6.1 Present location and rates of erosion	Topographic contour map	Use topographic contours to assist evaluating rates of erosion	Topographic survey of the site

8.3.1.14-20

CONSULTATION DRAFT

Table 8.3.1.14-2. Investigations and information needs that require parameters from the surface characteristics program (page 4 of 6)

Issue, investigation, or information need calling for data	Parameter	Why data needed	Type of study or analysis needed to develop parameter
INVESTIGATION 8.3.1.14.2 (SOIL AND ROCK PROPERTIES)			
2.3.1 Credible repository accidents (Section 8.3.5.5.1)	Physical and mechanical (static and dynamic) properties of soil and bedrock, alluvium bedrock contact, and layering	Evaluate the potential hazards from earthquakes and slope instabilities to structures and systems important to safety (60.131 (b) (1))	Standard laboratory and field static and dynamic tests
2.7.1 Radiological protection (Section 8.3.2.3.1)	Physical and mechanical (static and dynamic) properties of soil and bedrock, alluvium bedrock contact, and layering	Evaluate the potential hazards from earthquakes and slope instabilities to structures and systems important to safety (60.131 (b) (1))	Standard laboratory and field static and dynamic tests

8.3.1.14-21

CONSULTATION DRAFT

Table 8.3.1.14-2. Investigations and information needs that require parameters from the surface characteristics program (page 5 of 6)

Issue, investigation, or information need calling for data	Parameter	Why data needed	Type of study or analysis needed to develop parameter
INVESTIGATION 8.3.1.14.2 (SOIL AND ROCK PROPERTIES) (continued)			
4.2.1 Site performance information needed for design (Section 8.3.2.4.1)	Physical and mechanical (static and dynamic) properties of soil and bedrock, alluvium bedrock contact, and layering	To evaluate the potential hazards from earthquakes and slope instabilities to personnel	Evaluate ground-motion response due to earthquakes and conduct a static and dynamic analysis of proposed foundations and slopes
4.5 Total system costs (Section 8.2.2.3.2.4) ^a	Physical and mechanical (static and dynamic) properties of soil and bedrock, alluvium bedrock contact, and layering	Estimate the costs of surface facility design and construction	Evaluate ground-motion response due to earthquakes and conduct a static and dynamic analysis of proposed foundations and slopes

8.3.1.14-22

CONSULTATION DRAFT

Table 8.3.1.14-2. Investigations and information needs that require parameters from the surface characteristics program (page 6 of 6)

Issue, investigation, or information need calling for data	Parameter	Why data needed	Type of study or analysis needed to develop parameter
INVESTIGATION 8.3.1.14.2. (SOIL AND ROCK PROPERTIES) (continued)			
4.4.1 Site and performance information needed for design (Section 8.3.2.5.1)	Physical and mechanical (static and dynamic) properties of soil and bedrock, alluvium bedrock contact, and layering	Do technologies exist for cost effective surface construction on the site's soil and bedrock	Standard laboratory and field static and dynamic tests
8.3.1.17.3 Vibratory ground motion at site from potential man-made or natural seismic-induced events	Alluvium and bedrock stratigraphy and their compressive and shear wave velocities	Evaluate ground motion response due to seismic event for siting and designing surface facilities	Drilling, surface and borehole geophysical testing and laboratory tests to determine stratigraphy and wave velocities

^aCosts are not addressed in the SCP. They will be addressed during the environmental planning process.

Table 8.3.1.14-3. Investigations or information needs supplying data to the surface characteristics program

Surface characteristics investigation	Information needs and investigations providing data	Data needed by this program
8.3.1.14.1, topography	4.4.5, reference preclosure repository design (Section 8.3.2.5.5)	Location of proposed surface facilities and roads
8.3.1.14.2, soil and rock properties	4.4.5, reference preclosure repository design (Section 8.3.2.5.5)	Location of proposed surface facilities and roads
	8.3.1.17.2, fault displacement	Fault locations
	8.3.1.2.2, site unsaturated zone hydrologic system	Infiltration and run-off characteristics
	8.3.1.6.1, present locations and rates of surface erosion	Soil erosion potential

8.3.1.14-24

CONSULTATION DRAFT

CONSULTATION DRAFT

investigations, information needs, and the associated data that will be required by this program.

The schedule information provided for investigations in this section includes the sequencing, interrelationships, and relative durations of the studies in the investigation. Specific durations and start/finish dates for the studies are being developed as part of ongoing planning efforts and will be provided in the SCP at the time of issuance and revised as appropriate in subsequent semiannual progress reports.

Summary of studies

No studies are needed or planned for Investigation 8.3.1.14.1 (topography) because the requirements for this investigation have been satisfied.

The recommended studies to address the requirements of Investigation 8.3.1.14.2 (soil and rock properties) consist of an exploratory program, laboratory testing program, and a field testing and measurement program. The exploratory program will use various methods to investigate and characterize the subsurface soil and rock strata beneath the reference conceptual site. The laboratory test program will test undisturbed samples (minimal disturbance) obtained from the exploratory program to determine the soil or rock physical and mechanical material properties. The results from the field test and measurement program will further enhance the characterization of the subsurface conditions that may influence or impact surface facilities performance and design.

8.3.1.14.1 Investigation: Studies to provide the topographic characteristics of potential locations of surface facilities

Technical basis for obtaining the information

Link to the technical data chapters and applicable support documents

The topographic characteristics of the potential surface facility locations can best be illustrated with topographic contour maps. Topographic contour maps of the Yucca Mountain vicinity have been developed for use in the geologic, hydrologic, and climatologic site characterization studies described in this plan; numerous examples are presented as base maps in Chapters 1, 3, 5, and in Section 6.1.2.1.1 (topography and terrain) in Chapter 6. More detailed contour maps of the topography of potential repository surface facilities have been developed; examples are included in Section 6.2.4 (design of surface facilities).

Parameters

The following parameter has been measured or calculated as a result of site studies performed as part of this investigation: Ground-surface elevation as a function of geographic position at Yucca Mountain and vicinity.

CONSULTATION DRAFT

Purpose and objectives of the investigation

The purpose of this investigation was to evaluate the surface topographic elevation and relief at the potential surface facility locations to provide a basis for evaluating (1) the surface drainage, flood levels, and erosion characteristics in the vicinity of Yucca Mountain, (2) the cut-and-fill requirements for the design and engineering of the repository surface facilities, and (3) the stability of natural slopes and cut slopes. Topographic maps will be used in locating surface facilities, roads, and railways.

A knowledge of the surface topographic characteristics of the site will also be required for certain underground design and performance studies. The site's topography will have an influence on the underground design and the site's performance in terms of determining the usable area in the repository horizon while maintaining the required amount of overburden. A favorable site condition will exist if an overburden depth of 300 m is maintained above the repository horizon (10 CFR 60.122(b)(5)). The site will be disqualified if a minimum overburden depth of 200 m is not maintained (10 CFR 960.4-2-5(d)).

Another underground design parameter that is influenced by surface topography is in situ stress. In situ stresses are a result of three stress conditions: gravitational induced stress due to the weight of overburden, residual stress due to energy stored in the rock during the geologic past, and tectonic stress produced by current tectonic forces affecting the region. Bauer et al. (1985) evaluated the effect of Yucca Mountain's topography on gravitational induced horizontal stresses. Their study found that the surface topography will influence the horizontal stress field at the repository horizon.

The surface topographic information resulting from this investigation will contribute to data needs in the following design issues and characterization programs:

<u>Issue or program</u>	<u>Subject</u>
8.3.1.16	Preclosure hydrology. Topographic contours will be used to determine flood level.
4.5	Total system costs (Section 8.2.2.3.2.4). Topographic contours will be contributing information used in designing the repository and therefore influence cost. (This issue will be addressed after scoping hearings for the environmental impact statement.)
4.4	Preclosure design and technical feasibility (Section 8.3.2.5). Topographic contours will be used in the design and therefore influence the technical feasibility of the technologies required for repository construction, operation, closure, and decommissioning.

CONSULTATION DRAFT

<u>Issue or program</u>	<u>Subject</u>
1.11	Configuration of underground facilities (postclosure) (Section 8.3.2.2). Topographic contours will be used to determine if the site has less than 200 m of overburden, which would result in disqualification (Section 8.3.5.18). Topographic contours will also be used to determine if the site is favorable with a minimum overburden depth of 300 m (Section 8.3.5.17).
8.3.1.4	Rock characteristics. Topographic contours will be used to determine in situ stress at depth considering surface topography variations.
8.3.1.15	Thermal and mechanical properties. Topographic contours will be used to determine in situ stress at depth considering surface topography variations.

To control map compilation, a total of 623 control points were generated from 50 original ground-targeted points. Field surveys of the targeted points were contracted to a private survey firm. Elevation precision of targeted points is about 0.3 m (1 ft), and the size of the target about 0.6 m (2 ft), producing 80-micrometer images on photographs.

Aerial photographs of the Yucca Mountain region were taken in two phases. Phase 1 photography covered an area 10 by 14 km. Phase 2 photography covered an area 11 by 15 km, from 160°22'30" to 160°30'00" longitude and from 36°48' to 36°56' latitude. Photographs were taken by a 6-in. lens camera at a flight height of 1,140 m above the terrain; the photographic scale is 1:7,500.

Photogrammetric analysis included production of additional control points using analytical photogrammetric methods and map compilation on stereo plots. A total of 623 control points were produced from 179 aerial photographs. Control maps were compiled at a scale of 1:5,000 with a control interval of 1 to 2 m; each map covers an area 3 by 3 km, and has a precision of 10 cm on the ground.

Digital topographic data were collected from the contour maps. Three-dimensional modeling of the Yucca Mountain geology will be made by combining digital topographic and image data (Section 8.3.1.15.1). Topographic maps of appropriate portions of the Yucca Mountain area were compiled by Wu (1985) at 1 and 2 m contour intervals.

Technical rationale for the investigation

The requirements for this investigation have been satisfied. No further studies, tests, or analyses are planned.

CONSULTATION DRAFT

8.3.1.14.1.1 Application of results

The information derived from this investigation will be used to support the following investigations and information needs:

Information need
or investigation

Subject

- | | |
|------------|---|
| 1.11.1 | Site characteristics needed for design (determine if the 300-m overburden depth favorable condition in 10 CFR 60.122(b)(5) is satisfied and that the site is not disqualified on the basis of the minimum 200-m overburden requirement in 10 CFR 960.4-2-5(d)). |
| 8.3.1.4.3 | Three-dimensional rock characteristics model (determine in situ stress at depth considering surface topography variations) |
| 8.3.1.15.2 | Spatial distribution of ambient stress conditions (determine in situ stress at depth considering surface topography variations) |
| 8.3.1.6.1 | Present locations and rates of erosion (use topographic contours to assist evaluating rates of erosion) |
| 2.3.1 | Credible repository accidents (evaluate potential for slope instabilities and flooding) (Section 8.3.5.5.1) |
| 2.7.1 | Radiological protection (evaluate potential for slope instabilities and flooding) (Section 8.3.2.3.1) |
| 4.1.2 | Site meets qualifying conditions of technical guidelines (evaluate ease and cost of siting, construction, operation, and closure on topography of proposed site) (Section 8.3.5.7.2) |
| 4.2.1 | Site performance information needed for design (evaluate potential for slope instabilities and floodings) (Section 8.3.2.4.1) |
| 4.4.1 | Site and performance information needed for design (feasibility and cost effective technologies for construction and operation on topography of proposed site) (Section 8.3.2.5.1) |
| 4.5 | Estimates of the cost of reference and alternative repository designs--evaluate the effect of site topography on the cost of repository construction (Section 8.2.2.3.2.4) (the cost issue will be addressed during the environmental planning process) |

CONSULTATION DRAFT

Information need or investigation

Subject

- 8.3.1.16.1 Flood recurrence intervals and levels at surface facility locations (flood magnitudes and levels will be used in performance assessment and surface facility design studies)

Surface topographic contours will be an integral part of the siting, designing, and cost estimating for the repository's surface facilities. Thus, the results from this investigation will be part of the data requirements needed to resolve the respective issues for Information Needs 4.1.2 and 4.4.1, Issue 4.5, and Investigation 8.3.1.16.1. Data on topographic characteristics pertinent to addressing potential natural hazards from earthquakes and slope instabilities will be provided to Information Needs 2.3.1, and 2.7.1. Investigation 8.3.1.6.1 will need topographic data provided by this investigation to assist in the evaluation of erosion rates.

The topographic characteristics of the surface will also influence siting and designing the underground facilities of the repository. Information Need 1.11.1 will require topographic information to assess whether adequate overburden depth exists above the repository to satisfy the disqualifying condition in 10 CFR 960.4-2-5(d) and the favorable condition in 10 CFR 60.122(b)(5) described in Issues 1.9 and 1.8, respectively.

Surface topographic characteristics will also influence other underground design parameters such as in situ stress. The highly variable surface topography must be considered when evaluating the in situ stresses addressed in Investigations 8.3.1.4.3 and 8.3.1.15.2.

8.3.1.14.1.2 Schedule and milestones

No further activities are planned for this investigation.

8.3.1.14.2 Investigation: Studies to provide soil and rock properties of potential locations of surface facilities

Technical basis for obtaining the information

Link to the technical data chapters and applicable support documents

The following sections of the data chapters provide a technical summary of existing data relevant to this investigation:

<u>SCP section</u>	<u>Subject</u>
2.7.3	Geoengineering properties of surface materials
6.1.2.1.2	Near surface soil and rock
6.2.4	Design of surface facilities

CONSULTATION DRAFT

As discussed in Sections 6.1.2.1.2 and 6.2.4, limited preliminary field investigations (boring and test pits) and laboratory tests have been performed to estimate the soil properties and depth-to-rock. The results of these investigations suggest that the foundation soil or rock has adequate physical and mechanical characteristics for supporting the facility buildings and that ground motion amplification is not expected to be a problem. However, these investigations were only preliminary and the engineering properties were conservatively estimated using empirical correlations with soil classification methods. Therefore, further investigations are necessary to confirm these preliminary estimates.

Parameters

The characterization parameters that will be measured or calculated as a result of the site studies planned as part of this investigation were previously presented in Table 8.3.1.14-1. These data requirements are summarized in the following list:

1. Alluvial and rock stratigraphy and structure.
2. Soil and rock classification vs. depth.
3. Physical properties vs. depth.
4. Mechanical and dynamic properties vs. depth.
5. Compaction characteristics of soil.
6. Infiltration-runoff characteristics of soils and rock at surface (Investigations 8.3.1.2.2 and 8.3.1.6.1).
7. Erosion potential of undisturbed soil, cut slopes, and engineered fill slopes (Investigation 8.3.1.6.1).

Data similar to that described in the summarized list of data requirements will be obtained in two other investigations and one study:

<u>Investigation or study</u>	<u>Subject</u>
8.3.1.4.2	Geologic framework of the Yucca Mountain site
8.3.1.17.4	Preclosure tectonics data collection and analysis
8.3.1.5.1.4	Analysis of the paleoenvironmental history of the Yucca Mountain region

Because the objectives of these other investigations and studies are not always the same as that of the soil and rock investigation, differences may

CONSULTATION DRAFT

exist in the methods or techniques used to obtain the data. These differences may result in an incompatibility between the soil and rock investigation and the data from the previously described investigations and study. However, in the instances where the data are compatible, every effort will be made to coordinate the soil and rock investigation with similar data-gathering activities in the other investigations and studies.

Purpose and objectives of the investigation

The characteristics of the soil and rock at or near the surface will primarily influence the selection of the surface facilities locations and their design. The soil and rock conditions, as well as topographic relief, influence the specific locations selected for surface buildings, shaft and ramp entrances, and road and rail lines. They also provide information on infiltration-runoff characteristics and erosion potential so that the site drainage and erosion control systems can be designed when the facility design has been completed.

The most direct application of the soil and rock characterization activities will be to provide the necessary data to design surface structure foundations and retaining walls, evaluate the soil-structure interaction (response) due to earthquake loading conditions, and evaluate any potential slope instability conditions. Foundation designs will be necessary for various types of structures, including buildings, shaft hoist frames, and ramp portals.

The foundation design will consist of determining what type, size, and configuration of foundation would be most compatible with the soil or rock conditions, expected loads, function of structure, and design requirements. A determination of the allowable bearing load or pressure of the soil or rock will be a key factor in the foundation design analysis.

After the buildings, foundation, and superstructure have been designed for static-loading conditions, the soil or rock-structure interaction must be evaluated for earthquake loading conditions. In this instance, the number of stories and stiffness of the superstructure will affect the soil-structure response, but even more important will be the subsurface soil and rock conditions. Factors such as the thickness and inclination of an alluvial wedge, the seismic impedance contrast between the alluvium and bedrock, and the seismic absorptivity of the alluvium can all significantly contribute to ground motion response and therefore affect the interaction between the soil and structure.

The characterization of the soil and rock conditions will also be needed for evaluating any potential slope instabilities. Slope stability will be evaluated for road or rail line cuts, ramp portal entrances, and any potential unstable cut or natural slope near a surface facility.

The primary design issues that will be influenced by the soil and rock conditions are Issues 4.4 (Section 8.3.2.5) and 4.5 (total system costs, Section 8.2.2.3.2.4). These issues address whether available technologies exist to construct, operate, close, and decommission the repository, and to establish what costs are expected to design and construct the repository.

CONSULTATION DRAFT

Technical rationale for the investigation

The soil and rock properties investigation has been developed into three studies. These studies are further subdivided into activities. The studies and activities for the soil and rock investigation are as follows:

<u>Study</u>	<u>Activity</u>	<u>Subject</u>
8.3.1.14.2.1		Exploration program
	8.3.1.14.2.1.1	Site reconnaissance
	8.3.1.14.2.1.2	Preliminary exploration
	8.3.1.14.2.1.3	Detailed exploration
8.3.1.14.2.2		Laboratory test and material property measurements
	8.3.1.14.2.2.1	Physical property and index laboratory tests
	8.3.1.14.2.2.2	Mechanical and dynamic laboratory property tests
8.3.1.14.2.3		Field tests and characterization measurements
	8.3.1.14.2.3.1	Physical property and field tests and characterization measurements
	8.3.1.14.2.3.2	Mechanical property field tests
	8.3.1.14.2.3.3	Geophysical field measurements

The data obtained from this investigation will be primarily used in the resolution of Issues 4.4 (Section 8.3.1.2.5) and 4.5 (Section 8.2.2.3.2.4). As described earlier, and presented in the logic diagram for this program (Figure 8.3.1.14-1), Design Issue 4.4 addresses whether construction, operation, closure, and decommissioning technologies are adequately established to resolve performance issues, whereas Design Issue 4.5 will establish the costs to design, construct, operate, and decommission the repository such that performance issues are resolved. The cost issue will be addressed during the environmental planning process.

The main objective of the soil and rock investigation is to provide these design issues with the necessary geotechnical information to help locate the surface facilities, conduct foundation design analyses, evaluate soil-structure interactions, and if necessary, evaluate potentially unstable slopes. A secondary objective will be to provide these design issues with hydraulic-related soil information for evaluating erosion potential and infiltration-runoff characteristics. However, this hydraulic-related soil information will be contributed by Studies 8.3.1.2.2.1 and 8.3.1.6.1.1, which

CONSULTATION DRAFT

are outside this investigation. Other outside information contributing to this investigation will be from Activities 8.3.1.17.2.1.1, 8.3.1.17.4.2.1, and 8.3.1.17.4.2.2. These activities will provide information on surface fault locations that will be used in the surface facility siting process. The contribution from these outside activities to the soil and rock investigation, and ultimately the relevant design issues, is illustrated in Figures 8.3.1.14-1 and 8.3.1.14-2.

A generalized outline of the geotechnical information required for design is also presented in Figure 8.3.1.14-2 with the corresponding studies and activities that will provide this information. A list of the characterization parameters that will be developed from these studies and activities and provide the necessary geotechnical information required for the design process is presented in Table 8.3.1.14-1. Also provided in this table are the studies and activities associated with each of these characterization parameters.

The characterization parameters will be used to develop the design parameters as illustrated in Table 8.3.1.14-1. This is a key interlink since the design process is an iterative process between the surface facility design requirements (functions) and the soil and rock conditions. The surface facility design requirements and soil and rock conditions must both be considered when determining where to locate a surface facility, what type of foundation would be most appropriate, and evaluating the soil-structure interaction and the potential for unstable slope conditions. A preliminary evaluation of the site and a preconceptual design will determine more specifically what design parameters will be needed for further design activities and therefore what characterization parameters will be required to develop these design parameters. The interlink between the design parameters and the surface facility design requirements (functions) is presented in Section 8.3.2.5 (technical feasibility).

The recommended studies and their corresponding activities were listed previously in this section. These studies include (1) exploration program, (2) laboratory tests and material property measurements, and (3) field tests and characterization measurements.

The exploration program will evaluate all existing data (maps, aerial photographs, etc.), obtain representative samples from boreholes or trenches, and conduct geophysical surveys. Laboratory testing will be conducted on representative samples to determine the physical, mechanical, and dynamic properties of the soil and rock. Field tests will also be conducted on the soil and rock to better establish their physical, mechanical, and dynamic properties. Classification and characterization measurements and evaluations will be conducted on the soil and rock in both the laboratory and field.

The geotechnical exploratory program and its associated laboratory and field test programs will focus on the area east of Exile Hill for characterizing the foundation conditions for the central surface facilities area (Figure 8.3.1.14-3). Exploratory characterization activities will also be conducted in the areas of the ramp portals and shafts located west and north of the central surface facilities area. Additional foundation geotechnical exploration activities will be conducted at the bridge site over Fortymile Wash, which is located in the lower right-hand corner of Figure 8.3.1.14-3.

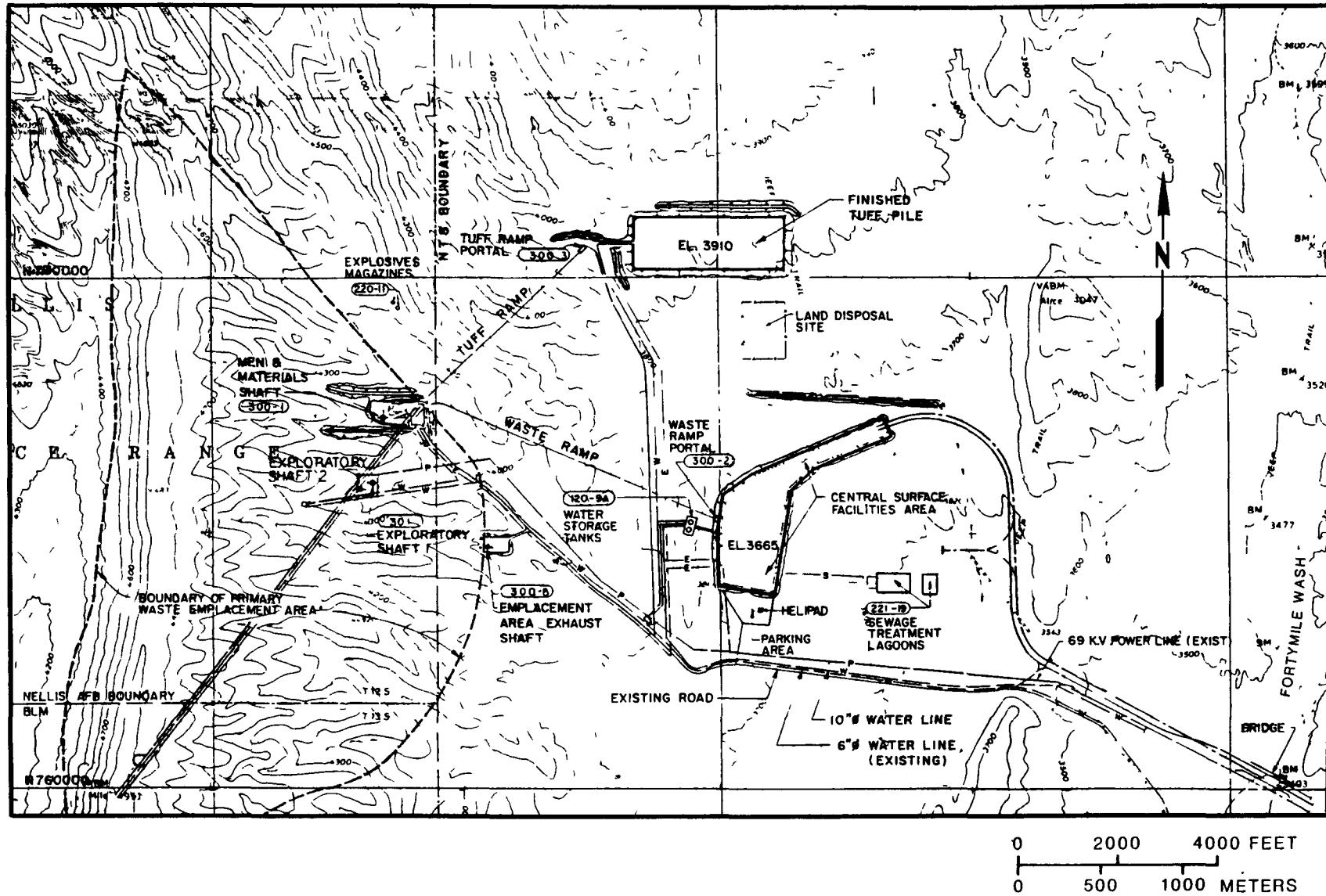

Figure 8.3.1.14-3. Site characterization plan-conceptual design overall site plan

CONSULTATION DRAFT

8.3.1.14.2.1 Study: Exploration program

The objectives of this study are to conduct an exploration program for characterization of the soil and rock conditions that will influence or be influenced by the construction of the surface facilities. The exploration program study will consist of three activities: (1) site reconnaissance, (2) preliminary exploration, and (3) detailed exploration. This study will evaluate all existing data and determine what additional and appropriate data will be needed to adequately address all design issues and characterization programs requesting data from this investigation (Figure 8.3.1.14-1). On the basis of these data needs and the expected soil and rock conditions at the site, an optimum exploration program will be developed and implemented to obtain this data using such methods as drilling, trenching, sampling, sounding, and geophysical surveys. The selection of the appropriate methods will be dependent on the specific requirements of each data need and the soil or rock conditions that are encountered.

Samples obtained from drilling or trenching will be used in the laboratory testing activities described in Study 8.3.1.14.2.2. Laboratory and field test results and the other geotechnical information developed during this study will contribute to the development of the geotechnical design parameters presented in Table 8.3.1.14-1, which in turn will be used to address Design Issue 4.4 (Section 8.3.2.5) and repository costs (Section 8.2.2.3.2.4).

8.3.1.14.2.1.1 Activity: Site reconnaissance

Objectives

The objectives of this activity are to review existing site information and conduct a field reconnaissance for the purpose of establishing a preliminary exploration program to include subsurface drilling, test pits, trenching, and geophysical methods. Data from this activity will contribute to the development of the geotechnical parameters in Table 8.3.1.14-1 and to the resolution of Design Issue 4.4 (Section 8.3.2.5) and repository costs (Section 8.2.2.3.2.4).

Parameters

The following data are required to fulfill the objectives of this activity:

1. Existing topographic (Investigation 8.3.1.14.1), soil, and geologic maps.
2. Existing subsurface drilling, trenching, and geophysical information.
3. Existing geologic and geotechnical reports.
4. Aerial photographs.

CONSULTATION DRAFT

5. Onsite visual reconnaissance.

Some preliminary site reconnaissance and data-gathering activities have already been completed in the Midway Valley-Yucca Mountain area. Four test pits were excavated in the alluvium at potential surface repository facility sites. These sites are located along the western edge of Midway Valley and the eastern edge of Yucca Mountain as illustrated in Figure 8.3.1.14-4. These exploratory activities were conducted to evaluate the conditions of the natural alluvial soils that are expected to support the foundations of the potential surface facility sites. Data collected from these activities include densities, moisture content, specific gravity, gradation analysis, and moisture-dry density compaction relationships (Ho et al., 1986).

Boreholes have also been drilled in the Midway Valley-Exile Hill area as illustrated in Figures 8.3.1.14-4 and 8.3.1.14-5. These boreholes were used to better define the geologic stratigraphy and structure of the preferred reference conceptual site (Figures 8.3.1.14-5, 8.3.1.14-6, 8.3.1.14-7, and 8.3.1.14-8) and to obtain preliminary physical property and wave velocity data from the alluvium and Tiva Canyon cap rock. These borehole data, plus seismic reflection and refraction surface survey data, were used to determine that the wedge angle between the alluvium and bedrock was low and that the seismic impedance contrast between the alluvium and Tiva Canyon cap rock was small. Both of these characteristics are important from the standpoint of evaluating potential seismic-induced ground motion. It was determined that neither the small wedge angle between the alluvium and bedrock nor the low seismic impedance contrast between the alluvium and bedrock would significantly amplify incoming seismic-induced ground motion (Neal, 1986).

Description

This activity will collect and evaluate all existing geotechnical and air photographic information that exists for the reference conceptual site east of Exile Hill, around shaft and ramp portals, at the tuff pile site, and at other locations associated with surface facilities, such as roads, bridges, and flood protection facilities (e.g., embankments, channels, and culverts). This information will be used in conjunction with an onsite visual reconnaissance to develop an optimum subsurface drilling, trenching, and geophysical survey program.

The previously described site reconnaissance information will be used to develop a preliminary exploration program plan. This plan will identify the type, location, spacing, and depth of subsurface borings, test pits, and trenches. The preliminary exploration program plan will also identify the method and location of recommended geophysical surveys. Recommendations for subsurface boring location, spacing, and depth are given in Hvorslev (1949), and U.S. Army EM 1110-1-1804.

Methods and technical procedures

A preliminary exploration program plan will be developed by analyzing and interpreting existing geotechnical and air photographic information, and the results of the onsite visual reconnaissance. Preliminary exploration

CONSULTATION DRAFT

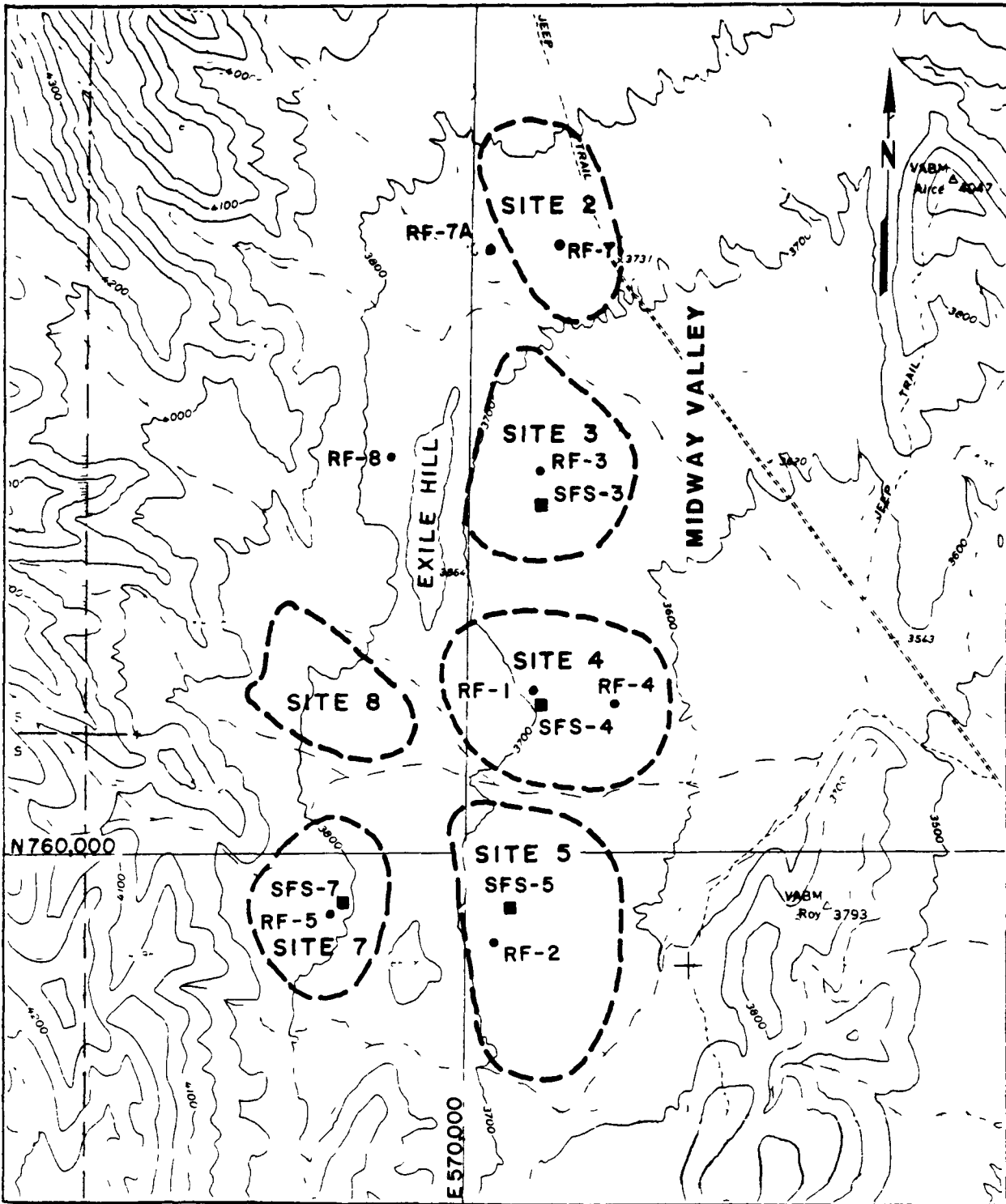

KEY

- SFS TEST PITS
- RF BORINGS

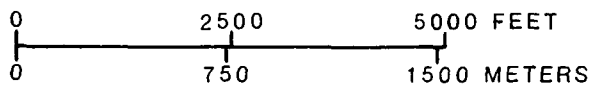

Figure 8.3.1.14-4. Location of surface test pits in alluvium Modified from Ho et al (1986)

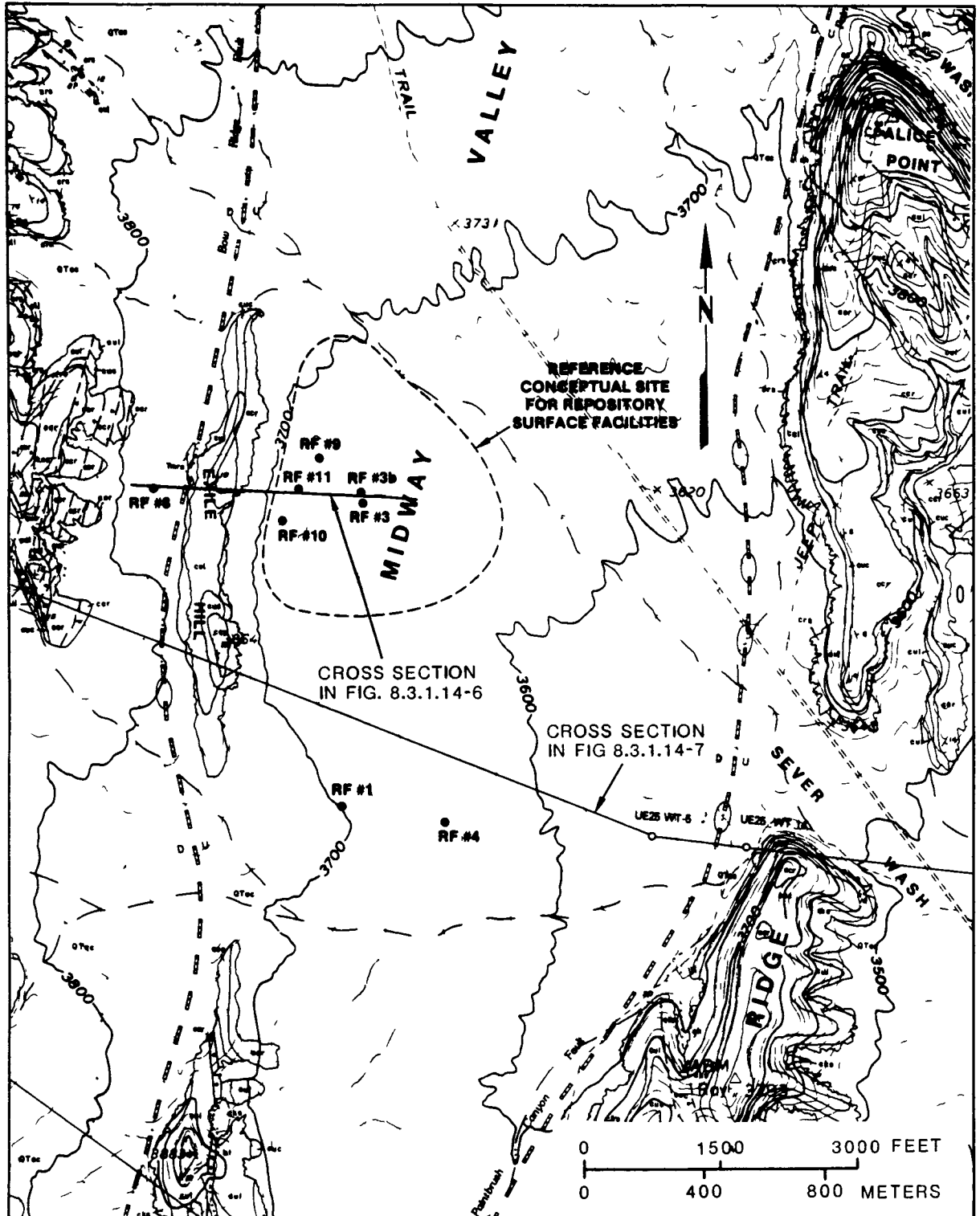

Figure 8.3.1.14-5. Map of the surface geology and faults in the vicinity of Exile Hill (Unit definitions are given on Figures 8.3.1.14-6 and 8.3.1.14-7) Modified from Scott and Bonk (1984)

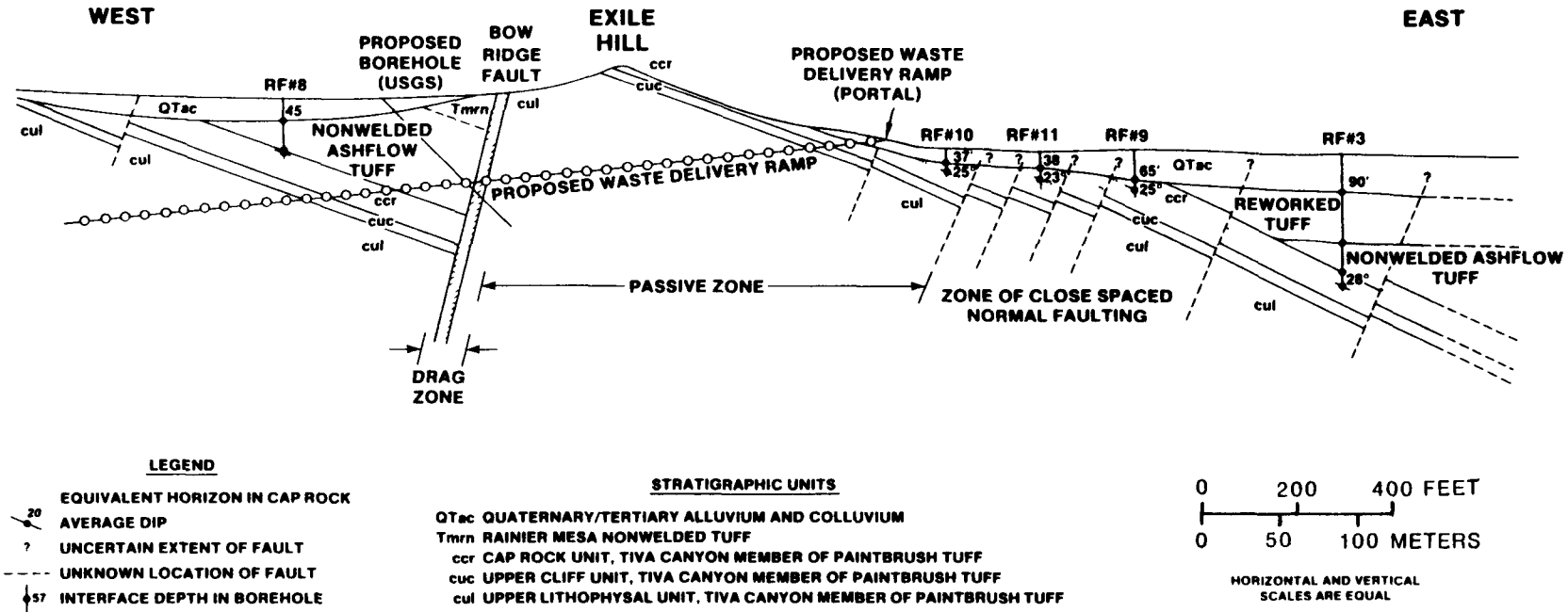
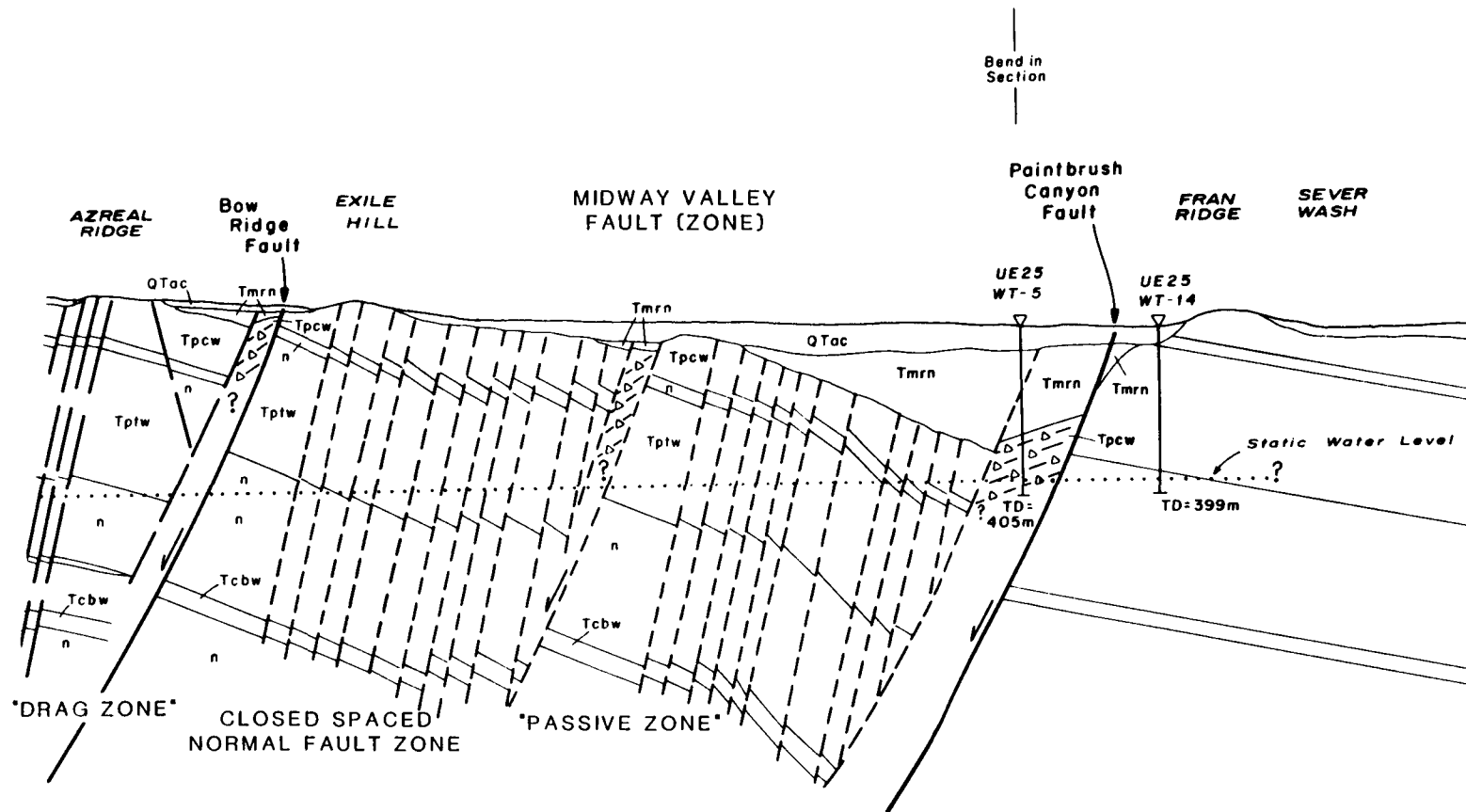

Figure 8.3.1.14-6. Cross section of the geologic structure through Exile Hill and the reference conceptual site based on surface mapping and borehole data (See Figure 8 3 1 14-5 for the location of the section) Modified from Scott and Bonk (1984)



- QTac QUATERNARY/TERTIARY ALLUVIUM AND COLLUVIUM
- Tmrn RAINIER MESA MEMBER OF TIMBER MOUNTAIN TUFF, NONWELDED
- Tpcw TIVA CANYON MEMBER OF PAINTBRUSH TUFF, WELDED
- n NONWELDED TUFF
- Tptw TOPOPAH SPRING MEMBER OF PAINTBRUSH TUFF, WELDED
- Tcbw BULLFROG MEMBER OF CRATER FLAT TUFF, WELDED
- TD TOTAL DEPTH

3000 FT

Figure 8.3.1.14-7. Conceptual cross section of the geologic structure south of the reference conceptual site for repository surface facilities. (See Figure 8.3.1.14-5 for the location of the section.) Modified from Scott and Bonk (1984).

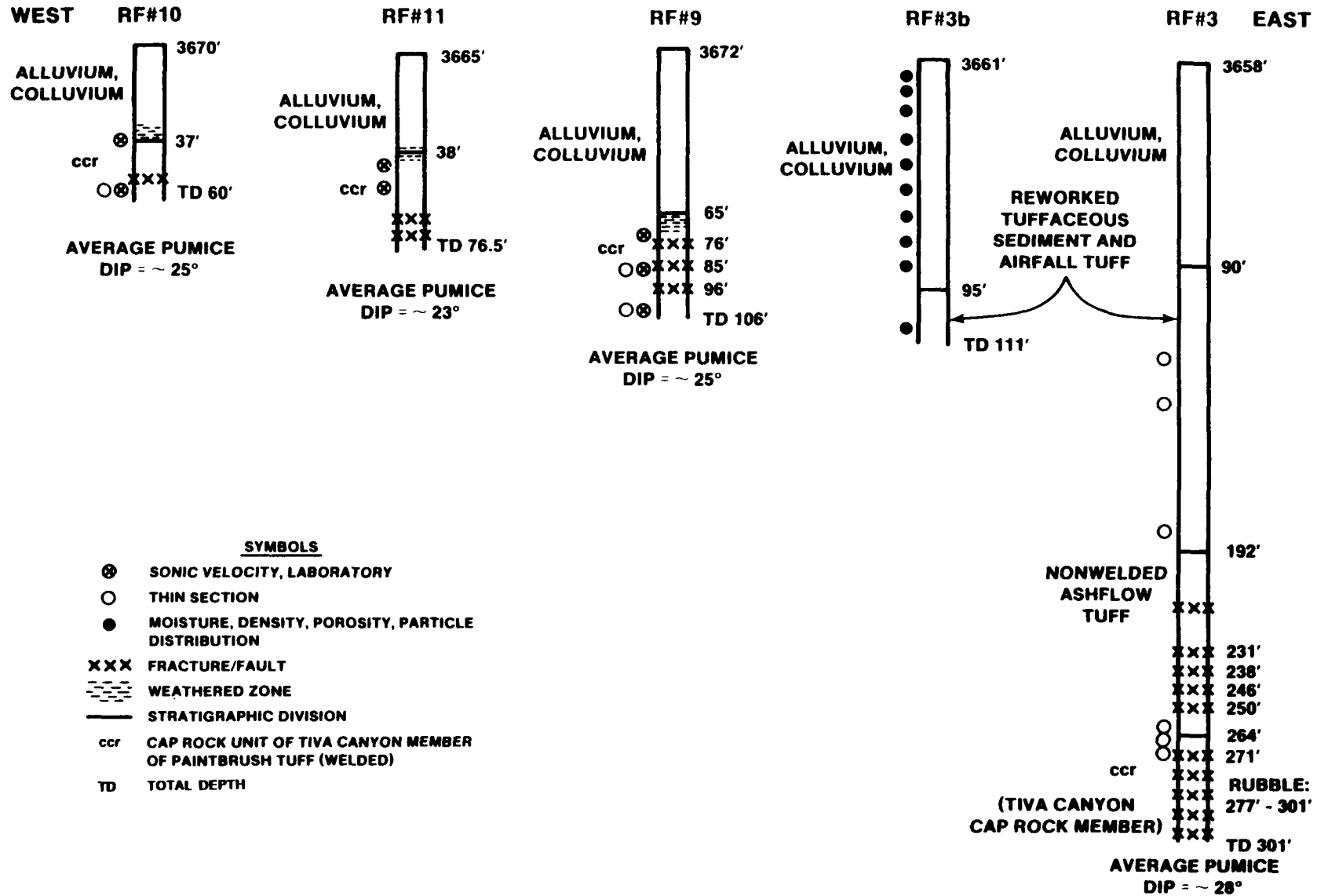

Figure 8.3.1.14-8. Summary of boreholes UE-25 RF#10, 11, 9, 3b, and 3, showing major stratigraphic units and features (See Figure 8.3.1.14-5 for the locations of the boreholes) To convert feet to meters, multiply by 0.3048. Modified from Scott and Bonk (1984)

CONSULTATION DRAFT

Method	Technical procedure		Date
	Number	Title	
Site reconnaissance and evaluation of existing data (maps, photos, existing reports)	U.S. Navy NAVFAC DM-7	Design manual - Soil mechanics, foundations, and earth structures	Mar 71
Site reconnaissance and evaluation of existing data (maps, photos, existing reports)	M. J. Hvorslev	Subsurface exploration and sampling of soils for civil engineering purposes	Nov 49
Site reconnaissance and evaluation of existing data (maps, photos, existing reports)	U.S. Army EM 1110-1-1804	Geotechnical investigations	Feb 84

specifications describing the type, location, spacing, and depth of subsurface borings, test pits, trenches, and geophysical surveys will be developed considering recommendations provided in the references listed in the following table (as well as similar references not listed).

8.3.1.14.2.1.2 Activity: Preliminary exploration

Objectives

The primary objective of the preliminary explorations is to obtain sufficient subsurface data to identify or verify the types, locations, and principal dimensions of all major surface structures comprising the proposed project. Preliminary designs based on these explorations will be suitable for economic and technical feasibility reports and project planning reports. The depth, thickness, and areal extent of all major soil and rock strata that will influence or be influenced by the construction of the surface facilities must be established in reasonable detail. In addition, disturbed and undisturbed samples must be obtained for laboratory testing to provide a basic knowledge of the engineering properties of the various strata.

CONSULTATION DRAFT

Parameters

The following data are required to fulfill the objectives of this activity:

1. Depth, thickness, and areal extent of all major soil and rock strata that will be within the zone of stress influence of surface facility loads or that may influence the soil-structure interaction response of the surface facilities under dynamic loading conditions.
2. Identification of existence of significant geologic structures.
3. Representative disturbed and undisturbed samples (undisturbed sampling will be very difficult in a nonsaturated cohesionless soil with cobbles).
4. Identification and classification of soil and rock types encountered.
5. Blow count or penetration resistance with depth in soils (sounding methods).
6. Schmidt impact hammer data for rock.
7. Preliminary determination of physical, mechanical, and dynamic properties developed from empirical methods related to material classifications, blow count or penetration resistance, Schmidt impact hammer data, and geophysical surveys and borehole logging.

Description

Field methods such as sounding, drilling, trenching, and test pits will be used in conjunction with geophysical methods to characterize the depth, thickness, and areal extent of all soil and rock strata that will be within the zone of stress influence of surface facility loads or that may influence the soil-structure interaction response of the surface facilities under dynamic loading conditions. These same methods can also be used to identify significant geologic structures such as faults in the vicinity of critical surface facilities. However, trenching will be the most reliable method for identifying faults in the alluvium at the site. The results of previous preliminary exploration activities (Ho et al., 1986) that were used to develop a conceptual design will be used in conjunction with the results of the exploration program described in this activity to develop an advanced conceptual design and provide the basis for developing a detailed exploration program.

Representative disturbed samples and undisturbed samples (if possible) of the soil and rock will be obtained from the drilling, trenching, and test pit activities for identification, classification, and laboratory testing of physical, mechanical, and dynamic properties. Undisturbed sampling of the unsaturated and cohesionless silty gravels or poorly graded gravels with cobbles at the site (Ho et al., 1986) will be difficult if not impossible.

CONSULTATION DRAFT

Preliminary evaluations of the physical, mechanical, and dynamic soil properties of the site will be developed from empirical methods related to material classifications, blow count of penetration resistance, Schmidt impact hammer data, and geophysical surveys and borehole logging. Sounding methods such as the Standard Penetration Test (SPT) (ASTM, 1974), the Dutch cone penetration resistance (ASTM, 1979), or the Becker penetration resistance (Harder and Seed, 1986) can be used to estimate the physical or mechanical properties of soil. Established empirical relationships can be used to correlate the soil classification and blow count or penetration resistance data to density, Young's modulus, or friction angle (Winterkorn and Fang, 1975). It is recommended that the Becker penetration resistance method be used for coarse gravels that are anticipated at the site. The use of sounding methods such as the SPT blow count or the Dutch cone penetration resistance in coarse gravels may provide unreliable data. If finer grained soil conditions are encountered, then it is recommended to use the SPT blow count method or the Dutch cone penetration resistance method.

Field methods can also be used to provide preliminary estimates of the mechanical rock properties of the site. The point load test (Broch and Franklin, 1972) is commonly used on rock core to estimate its unconfined compressive strength. The Schmidt impact hammer can also be used on rock core or surface outcrops to estimate unconfined compressive strength (ISRM, 1981). These are both very fast, inexpensive, but not necessarily reliable field methods.

Surface and borehole geophysical methods will be used to evaluate the dynamic and physical properties of the subsurface strata. The use of geophysical borehole logging will only be considered below the depth of the trenches or test pits. It will be used to correlate strata between boreholes and provide very approximate values for density, moisture content, porosity, wave velocities, and estimates of the degree of fracturing in rock.

The need for seismic geophysical methods is more apparent. Geophysical methods such as seismic refraction, cross-hole seismic, and up/downhole seismic are recommended for determining the compressive and shear wave velocities of the subsurface strata. The wave velocities will then be used to calculate the dynamic elastic parameters of the subsurface soil and rock. These field parameters are expected to be more reliable than the same parameters measured in the laboratory.

Methods and technical procedures

The following is a list of possible methods that may be used to obtain the data required to fulfill the objectives of this activity. The selection of the most appropriate methods will depend on the soil or rock conditions encountered and the data or parameters required.

1. Subsurface drilling, test pits, and trenching.
2. Sounding (probing) subsurface strata.
3. Geophysical surface surveys.
4. Geophysical borehole logging.
5. Surface and subsurface sampling.

CONSULTATION DRAFT

The previously described methods with their corresponding technical procedures are listed in the following table.

Method	Technical procedure		Date
	Number	Title	
Sounding, sampling, classification, drilling, trenching, and geophysical surveys for soils	U.S. Navy NAVFAC DM-7	Design manual - Soil mechanics, foundations, and earth structures	Mar 71
Sounding, drilling, trenching, geophysical surveys and borehole logging, and sampling	M.J. Hvorslev	Subsurface exploration and sampling of soils for civil engineering purposes	Nov 49
Sampling for soils	U.S. Army EM 1110-2-1907	Soil sampling	31 Mar 72
Dynamic sounding (blow count) in soils	ASTM D-1586-67	Penetration test and split-barrel sampling of soils	1974
Dynamic sounding (blow count) in soils	UCB-EERC-86-06 Harder & Seed	Determination of penetration resistance for coarse grained soils using the Becker Hammer Drill	1986
Static sounding-penetration resistance in soils (Dutch cone test)	ASTM D-3441-79	Deep, quasi-static, cone and friction-cone penetration tests of soil	1979
Mechanical properties of rock (indirect)	ISRM Doc. 5, Part 3	Suggested method for determination of the Schmidt Rebound Hardness	Mar 77
Geophysical borehole logging	ISRM Parts 1-11	Suggested methods for geophysical logging of boreholes	1981
Soil classification	ASTM D-2488-69	Description of soils (visual-manual procedure)	1969

8.3.1.14.2.1.3 Activity: Detailed exploration

Objectives

The objective of the detailed exploration activity is to fill in any gaps in the previous preliminary exploration activity and to make such additional explorations that are necessary to define adequately the subsurface conditions. When the subsurface information from the preliminary and detailed exploration activities are combined, the resulting information must be adequate for preparation of bidding plans and specifications for construction.

Parameters

The detailed exploration will conduct activities to improve on the understanding and confidence of the parameters and data identified in the preliminary exploration activity. The soil or rock conditions encountered during the preliminary exploration activities will determine which parameters will require further investigations during the detailed exploration activities or which contingent parameters will require characterization. The results of the preliminary exploration activities may indicate that certain parameters will not require further characterization.

Description

This activity will be an extension of the preliminary exploration program to better define a three-dimensional model or view of subsurface conditions that will influence or be influenced by the construction of surface facilities. Additional boreholes will be drilled or trenches dug at locations planned for critical surface structures or where subsurface conditions are not adequately understood or are highly varied.

In this activity the precise location of each surface facility has been set, and additional borings are made so that an adequate number of borings are located at each surface facility site. During the preliminary exploration, soil or rock conditions may have been encountered that will require different or modified detailed exploration methods. Otherwise, the type of exploration methods used in this activity will be similar to the methods used in the preliminary exploration activity.

Attempts may be made to obtain undisturbed samples; however, the undisturbed sampling of a dry cohesionless soil with cobbles may be difficult if not impossible. The presence of cobbles will require larger samples so that the characteristics of the soil mass will not be overshadowed by the presence of cobbles.

Due to the probable difficulty that will be encountered when attempting to obtain undisturbed samples, it may be necessary to obtain disturbed samples and recompact these samples to the in situ density before testing. The testing of recompacted soil has two disadvantages. The first consideration is that any effects of cementing or fabric will be destroyed by disturbing the sample. The second consideration is that some potential collapse characteristics of the soil sample, if present, may be lost due to the disturbance.

CONSULTATION DRAFT

Methods and technical procedures

The same methods and technical procedures described and referenced in the preliminary exploration activity (8.3.1.14.2.1.2) will be used in the detailed exploration activity. However, if unexpected soil or rock conditions are encountered in the preliminary exploration, then different or modified methods and technical procedures may be required for the detailed exploration activity.

8.3.1.14.2.2 Study: Laboratory tests and material property measurements

The objective of this study is to conduct laboratory tests and material property measurements on representative samples of soil and rock. These tests and measurements are intended to determine physical, mechanical, and dynamic properties. Additional tests and measurements will be conducted on soils to determine index properties and moisture-density compaction curves for potential fill material. Geotechnical information from this study will contribute to the development of the geotechnical design parameters presented in Table 8.3.1.14-1, which in turn will be used to address Design Issue 4.4 (Section 8.3.2.5) and repository costs (Section 8.2.2.3.2.4).

8.3.1.14.2.2.1 Activity: Physical property and index laboratory tests

Objectives

The objective of this activity is to measure the soil or rock weight and volume components using physical property tests. Soils can be further characterized by index tests such as gradation analysis and Atterberg limits testing. The physical and index property test results are used to classify soils and rocks, to group soils and rocks in major strata, and to extrapolate results from a restricted number of mechanical and dynamic properties tests to determine properties of other similar materials. Empirical methods can also be used to relate the physical properties and soil or rock classifications to engineering parameters.

Parameters

The following soil and rock parameters will be collected, evaluated, or both to fulfill the objectives of this activity.

1. Soil parameters
 - a. Density.
 - b. Specific gravity.
 - c. Moisture content.
 - d. Soil classification.
 - i. Gradation analysis.
 - ii. Atterberg limits (this parameter will only be determined if cohesive soils are encountered).
 - e. Moisture-density compaction curves for potential fill material.

CONSULTATION DRAFT

- f. Relative density (cohesionless soils).
2. Rock parameters
- a. Density.
 - b. Moisture content.
 - c. Porosity.
 - d. Specific gravity.

Description

A representative number of samples will be tested so that the variations in physical and index properties throughout the reference conceptual site will be adequately characterized. The laboratory soils tests can be conducted on disturbed samples except for the density and porosity tests. These two soil tests will require undisturbed samples. Because of the difficulty in obtaining an undisturbed sample from a dry cohesionless soil with cobbles, soil densities will have to be determined in situ using either field density test methods, or empirical correlations with sounding methods such as the Standard Penetration Test (SPT) blow count data (Winterhorn and Fong, 1975) or Becker penetration resistance data (Harder and Seed, 1986).

Because of the very coarse nature of the soil, it may not be possible to use the Standard Proctor or Modified Proctor compaction methods to develop the moisture-dry density compaction curve relationships of the soil. For gravelly soils, up to 3-in. maximum size, it is recommended that the U.S. Bureau of Reclamations E-38 procedure be used to develop compaction curves.

Methods and technical procedures

Standard soil testing and classification procedures will be used for Activity 8.3.1.14.2.2.1. A list of possible tests and classification methods follows.

Method	Technical procedure		Date
	Number	Title	
Sample preparation for soils	ASTM D421-58	Dry preparation of soil samples for particle-size analysis and determination of soil constants	1978
Moisture content for soil and rock	ASTM D2216-80	Laboratory determination of water (moisture) content of soil, rock, and soil-aggregate mixtures	1980
Density of soil	ASTM D2937-83	Density of soil in place by the drive-cylinder method	1983

CONSULTATION DRAFT

Method	Technical procedure		Date
	Number	Title	
Specific gravity for soil			
Materials smaller than number 4 sieve	ASTM D854-83	Specific gravity of soils	1983
Materials larger than number 4 sieve	ASTM C127	Test method for specific and absorption of coarse aggregate	
Atterberg limits ^a			
Liquid and plastic limits	ASTM D4318-83	Liquid limit, plastic limit, and plastic index of soils	1983
Shrinkage limit	ASTM D427-83	Shrinkage factors of soils	1983
Soil Gradation			
Sieve analysis	ASTM D422-63	Particle-size analysis of soils	1972
Hydrometer analysis	ASTM D422-63	Particle-size analysis of soils	1972
Compaction moisture-density relationships			
Standard Proctor	ASTM D698-78	Moisture-density relations of soils and soil-aggregate mixtures using 5.5-lb. hammer and 12-in. drop	1978
Modified Proctor	ASTM D1557-78	Moisture-density relations of soils and soil-aggregate mixtures using 10-lb hammer and 18-in. drop	1978
U.S. Bureau of Reclamation (gravelly soils--3 in. maximum size)	E-38 (Earth Manual)	Compaction test for soil containing gravel	1980
Soil classification	ASTM D2487-83	Classification of soils for engineering purposes	1983
Relative density	ASTM D4254-83	Minimum index density of soils and calculation of relative density	1983

CONSULTATION DRAFT

Method	Technical procedure		Date
	Number	Title	
Porosity/density for rock	ISRM Doc. 6 Part 1, No. 2-5	Suggested method for porosity/density determination	Mar 77
Moisture content for rock	ISRM Doc. 6 Part 1, No. 1	Suggested method for determination of water content	Mar 77
Specific gravity for rock	ISRM Doc. 6 Part 1, No. 4	Suggested method for porosity/density determination	Mar 77

^aAtterberg limits will be required only if cohesive soils are encountered.

8.3.1.14.2.2 Activity: Mechanical and dynamic laboratory property tests

Objectives

The objective of this activity is to measure in the laboratory the static and dynamic deformation and strength characteristics of soil and rock samples obtained from the exploratory program. The results of this testing will be used to evaluate bearing capacity, earth pressures, shear strength parameters, slope stability, settlement and swelling potentials, and the dynamic characteristics of the soil and rock. This geotechnical information will be used for locating and designing buildings, foundations, retaining walls, backfills, roads, and slopes. Results from this activity will be the major contributor for developing the geotechnical design parameters presented in Table 8.3.1.14-1.

Parameters

The data and parameters listed in this section will be collected, evaluated, or both, to fulfill the objectives of the activity.

1. Required static load derived parameters.
 - a. Mohr-Coulomb strength criteria parameters for soils (cohesion and angle of friction). The type of strength testing will depend on the type of soil, stress history, new stress state, and rate of loading.

CONSULTATION DRAFT

- b. Peak and residual failure envelopes for rocks.
 - c. Young's modulus.
 - d. Poisson's ratio.
 - e. Shear modulus.
 - f. Rock discontinuity shear strength parameters in terms of cohesion and angle of friction.
 - g. Plate load pressure versus settlement.
2. Contingent static load derived parameters.
- a. Collapse potential (for relatively dry, low-density soils).
 - b. Coefficient of consolidation (for saturated, clayey soils).
 - c. Compression and swell index (for saturated, clayey soils).
 - d. Other failure criteria parameters such as Drucker-Prager or Hoek and Brown.
 - e. Deformation modulus of soils in terms of stress-strain characteristics and confinement stress conditions.
 - f. Bulk modulus and constrained modulus of soils.
3. Required dynamic load derived parameters.
- a. Compressive wave velocities versus depth.
 - b. Shear wave velocities versus depth.
 - c. Damping versus depth.
4. Contingent dynamic load derived parameters.
- a. Strength and stress-deformation characteristics of soil under dynamic load conditions evaluated as a function of stress rates, confinement stress, initial static stress level, magnitude of pulsating stress, number of stress cycles, and frequency of loading.
 - b. Dynamic shear modulus as a function of strain and confinement stress.
 - c. Damping as a function of strain.
 - d. Shear wave velocities as a function of strain.
 - e. Liquefaction parameters--cyclic shearing stress ratio, cyclic deformation, and pore-pressure response (applicable for soils with perched water tables near the surface).

CONSULTATION DRAFT

The need for any contingent parameters will be determined by the soil or rock conditions encountered, the function or design requirements of the surface facilities, the types of foundations selected, and the type or sophistication of the analyses that are selected for the design or performance studies. On the basis of the known site conditions and the design presented in the SCP-CDR (SNL, 1987), these contingent parameters are not presently required. The contingent parameters will be characterized if unexpected soil and rock conditions are encountered, or if more sophisticated constitutive models are required or used in the soil or rock-structure interaction numerical codes.

Description

Standard laboratory tests for geotechnical engineering practice will be performed. Testing will be conducted on undisturbed or recompacted samples taken from soil and rock strata that will influence or is influenced by surface facility construction. Selection of sample location, depth, and type of test will be influenced by the surface structure function, loads (static or dynamic), and foundation depths and widths. Testing will also be conducted on all soils to be used for engineered fills. These soils must be compacted to the appropriate dry density and moisture content before conducting laboratory tests to determine their mechanical and dynamic properties.

The static strength and deformability of cohesionless soils will be determined in the laboratory from the results of triaxial compression tests and direct shear tests. The results of this testing will be used to confirm or validate the mechanical parameters determined in the field using empirical correlations with soil classification, density, and blow count data. Additionally, plate load bearing tests may be used if spread footings are recommended for the design. Unconfined compressive tests can also be conducted if cohesive soils are encountered.

The type of test or method selected to determine the settlement characteristics of the soil will depend on whether the soil is cohesionless or cohesive. The immediate settlement characteristics of a cohesionless soil will be determined by an analytical method developed by Schmertmann (1970) based on the results of Standard Penetration blow count data or Dutch cone penetration resistance data. The time-dependent settlement characteristics of a saturated cohesive soil will be developed from the results of one-dimensional consolidation tests, however, saturated cohesive soils are not expected to be encountered.

The strength and deformability of rock will be determined in the laboratory from the results of triaxial compression tests, unconfined compression tests, and Brazilian tensile tests. The strength parameters will be in the form of peak and residual strength envelopes. These parameters will be used to evaluate the allowable foundation bearing pressure of the rock (Goodman, 1980).

The direct shear testing method can be used in the laboratory to measure the mechanical properties of the rock discontinuities. The discontinuity strength parameters will be used in the stability evaluation of rock slopes and will contribute to the evaluation of the allowable bearing pressure for a foundation, especially for foundations on sloping topography.

CONSULTATION DRAFT

The velocity characteristics of the propagation of elastic waves through soil and rock can be determined in the laboratory using resonant methods. High- and low-frequency ultrasonic pulse techniques can also be used for rock. The resulting velocities from these tests can then be used to determine the elastic deformation parameters of the soil or rock. Elastic deformation parameters derived from laboratory resonant test methods will only be used to confirm or validate the elastic deformation parameters derived from field geophysical seismic methods. However, the material damping characteristics of the soil or rock will be determined in the laboratory using resonant test methods.

Determination of the dynamic compression and shear moduli will depend primarily on field geophysical seismic methods, such as, cross hole and up/downhole measurement techniques. Using these techniques, the maximum dynamic shear modulus (low-strain) can be obtained. The nonlinearity of soil can be considered by reducing the shear modulus with strain based on correlations developed by Seed et al. (1984). It is also recommended that the relationship developed by Seed et al. (1984) be adopted to determine the maximum shear modulus of soil as a function of a density related factor, K_2 , (obtainable from the field measured shear wave velocities) and the mean effective confining stress. A method for reducing the shear modulus of rock as a function of strain is addressed by Schnabel et al. (1971).

The determination of the strength and stress-deformation characteristics of soils under dynamic load conditions evaluated as a function of stress level, magnitude of pulsating stress, number of stress cycles, and frequency of loading can only be determined in the laboratory using a cyclic loaded triaxial compression test. However, because of the difficulty in obtaining undisturbed samples of the coarse cohesionless soils at the site and the resulting unreliable nature of these samples or recompacted samples, it is recommended that the cyclic loaded triaxial compression test not be conducted if sufficient confidence can be acquired in the previously described field and empirical methods for determining the dynamic mechanical characteristics of the soil. Certain conditions may develop that will either require or produce more of a need for cyclic loaded triaxial test data. These conditions would include a lack of confidence in the previously described field and empirical methods, therefore, requiring the cyclic loaded triaxial test as a means of confirming or validating the parameters developed from the field and empirical methods. In addition, this test would provide the design engineer with more information to better assess the dynamic characteristics of the soil (assuming the data is not totally invalidated due to sample disturbance or questionable testing procedures). The need and validity of the cyclic loaded triaxial test may increase if other soil conditions are encountered such as saturated soils or finer grained soils. Other conditions that may require the implementation of cyclic loaded triaxial test methods are the use of more sophisticated constitutive models in the soil structure interaction numerical codes.

Methods and technical procedures

Standard testing procedures will be used and a list of possible test methods are given in the following table. The selection of the most appropriate method will depend on the soil or rock conditions that are encountered

CONSULTATION DRAFT

in the exploration activities and the type or sophistication of the analyses that are selected or required for design or performance studies.

Method	Technical procedure		Date
	Number	Title	
Drained triaxial strength of granular soils	Bishop and Henkel	The measurement of soil properties in the triaxial test	1974
Unconfined compression testing for cohesive soils ^a	ASTM 2166-66	Unconfined compressive strength of cohesive soils	1979
Triaxial compression testing for soils ^a	ASTM D2850-82	Unconsolidated, undrained compressive strength of cohesive soils in triaxial compression	1982
Direct-shear strength for soils	ASTM D3080-72	Direct shear test of soils under consolidated drained conditions	1979
Compressibility-swell test for soils ^a	ASTM D2435-80	One-dimensional consolidation properties of soils	1980
Resonant column test for soil	ASTM D4015-81	Modulus and damping of soils by the resonant-column method	1981
High-frequency ultrasonic pulse technique for rock	ISRM, Doc. 4, pp. 108-109	Suggested methods for determining sound velocity	Mar 77
Low-frequency ultrasonic pulse technique for rock	ISRM, Doc. 4, pp. 109-110	Suggested methods for determining sound velocity	Mar 77
Resonant method test for rock	ISRM, Doc. 4, p. 110	Suggested methods for determining sound velocity	Mar 77

CONSULTATION DRAFT

Method	Technical procedure		Date
	Number	Title	
Unconfined compressive strength of rock core	ISRM Part 1	Suggested method for determination of the uniaxial compressive strength of rock materials	Sept 78
Unconfined compressive deformability of rock core	ISRM Part 2	Suggested method for determining deformability of rock materials in uniaxial compression	Sept 78
Triaxial compressive strength of rock core	ISRM, Doc. 7	Suggested methods for determining the strength of rock materials in triaxial compression	Mar 77
Triaxial compressive strength and deformability of rock core	ASTM D2664-80	Triaxial compressive strength of undrained rock core specimens without pore pressure measurements	1980
Indirect tensile strength of rock discontinuities	ISRM, Doc. 8, Part 2	Suggested method for determining indirect tensile strength by the Brazil test	Mar 77
Direct shear strength of rock discontinuities	ISRM, Doc. 1, Part 2	Suggested method for laboratory determination of direct shear strength	Feb 74

^aThe need for these test methods is contingent on encountering cohesive soils. Based on known site conditions, cohesive soils are not expected.

8.3.1.14.2.3 Study: Field tests and characterization measurements

The objective of this study is to conduct field tests and characterization measurements. These field tests are intended to determine the in situ physical, mechanical, and dynamic properties of the soil and rock. Characterization measurements will be conducted on the rock for the purpose of classifying the rock and quantitatively describing the rock structure. Geophysical field measurements will help develop a three-dimensional model of

CONSULTATION DRAFT

the subsurface soil and rock strata in addition to determining their dynamic properties. Geotechnical information from this study will contribute to the development of the geotechnical design parameters presented in Table 8.3.1.14-1, which in turn will be used to address Design Issue 4.4 (Section 8.3.2.5) and repository costs (Section 8.2.2.3.2.4).

8.3.1.14.2.3.1 Activity: Physical property field tests and characterization measurements

Objectives

The objectives of this activity are to classify and describe the soil and rock conditions in the field and to determine their physical properties. The results of these tests and measurements will be used to develop preliminary estimates of the engineering characteristics of the soils and rocks. In addition, these properties and measurements will aid in the grouping of soils and rocks into stratigraphic units and the extrapolation of results from a restricted number of mechanical and dynamic properties tests to zones of soil and rock with similar material properties.

Parameters

The data and parameters that will be evaluated, collected, or both, to fulfill the objectives of this activity are as follows:

1. Soil
 - a. Density.
 - b. Relative density (from standard penetration blow count data on cohesionless soils).
2. Rocks
 - a. Rock mass classification:
 - i. Q-Norwegian Geotechnical Institute (NGI) Tunneling Quality Index.
 - ii. RMR--rock mass rating from South African Council for Scientific and Industrial Research (CSIR) Geomechanics Classification.
 - b. Rock structure
 - i. Quantitative description of faults
 - (a) Location
 - (b) Orientation

CONSULTATION DRAFT

- (c) Aperture
 - (d) Type of infilling
 - (e) Moisture and seepage conditions
 - (f) Waviness and roughness
- ii. Quantitative description of joints
- (a) Number of joint sets
 - (b) Spacing of joints for each set
 - (c) Orientation of each joint set
 - (d) Type of infilling if any
 - (e) Moisture and seepage conditions
 - (f) Waviness and roughness
 - (g) Persistence
 - (h) Drill core (total core recovery, discontinuity frequency, and rock quality designation (RQD))

Description

Standard geotechnical engineering field tests and characterization activities will be conducted. A representative number of tests and characterization activities will be conducted throughout the reference conceptual site so that variations in physical properties and characteristics will be adequately understood.

Soils density in the field can be determined by any one of the four different methods described in the following "Methods and technical procedures" section. However, the sand-cone method is the most commonly used method for measuring density in the field. Estimates of relative density in cohesionless soils can be made empirically from Standard Penetration Test (SPT) blow count data. However, SPT blow count data is invalid for the coarse grained gravels found during the previous exploratory activities of the site (Ho et al., 1986). Therefore, the Becker penetration resistance method will be used to obtain blow count data in the coarse gravels and then correlated with equivalent SPT blow count data (Harder and Seed, 1986).

Rock mass classification data will be developed from two commonly used methods. The first method is called the tunneling quality index (Q) method and was developed by the Norwegian Geotechnical Institute, while the second method is referred to as the rock mass rating (RMR) method and was developed by the South African Council for Scientific and Industrial Research. Rock mass classification data can be used to provide preliminary estimates of rock strength and deformation characteristics. However, its primary purpose is to evaluate the stability and required support or reinforcement for subsurface excavations. This characterization data can contribute to locating and designing surface facilities such as ramp portals and shaft collars.

Rock mass discontinuities will be quantitatively described using methods recommended by the International Society for Rock Mechanics Commission on Standardization of Laboratory and Field Tests. These data will be used in conjunction with the rock mass classification data to evaluate the stability of any potentially hazardous rock slopes and to contribute to a better understanding of the engineering characteristics of the rock mass.

CONSULTATION DRAFT

Methods and technical procedures

Standard testing procedures will be used by this activity. A list of possible test methods follows:

Method	Technical procedure		Date
	Number	Title	
Density of soil in place	ASTM D2937-83	Density of soil in place by the drive-cylinder method	1983
Density of soil in place	ASTM D1556-82	Density of soil in place by the sand-cone method	1982
Density of soil in place	ASTM D2167-66	Density of soil in place by the rubber-balloon method	1977
Density of soil in place	ASTM D2922-81	Density of soil and soil-aggregate in place by nuclear methods (shallow depth)	1981
Density of soil in place (U.S. Bureau of Reclamation)	E-24 (Earth Manual)	Field density procedure test	1980
Quantitative description of rock mass discontinuities	ISRM, Part 1 No. 1-11	Suggested methods for the quantitative description of discontinuities in rock masses	1978
Rock mass classification, rock mass rating (RMR)	Bieniawski, Z. T.	Rock mass classification in rock engineering	1976
Rock mass classification, tunneling quality (Q)	Barton, Lien, and Lunde	Engineering classification of rock masses for the design of tunnel support	1974

8.3.1.14.2.3.2 Activity: Mechanical property field tests

Objectives

The objective of this activity is to measure the deformation and strength characteristics of in situ soil and rock conditions. The results of this testing will be used to evaluate bearing capacity, earth pressures,

CONSULTATION DRAFT

settlement and swelling potentials, slope stability, and the dynamic response of soil and rock for the design of foundations, retaining walls, backfills, roads, and slopes.

Parameters

The data and parameters that will be collected, evaluated, or both, to fulfill the objective of this activity are listed in this section.

1. Required parameters for soil (these parameters will be developed from empirical relationships using the following possible data: Dutch cone penetration resistance, Standard Penetration Test (SPT) blow count, Becker penetration resistance, relative density and soil classification or gradation).
 - a. Indirect estimates of Mohr-Coulomb shear strength parameters.
 - b. Indirect estimates of stiffness or Young's modulus for use in evaluating immediate settlement (compression).
2. Contingent parameters for soil.
 - a. Plate load bearing pressure versus settlement (this will be applicable if spread footings are considered in the design).
 - b. Modulus of subgrade reaction from plate load test (static or dynamic).
 - c. Pile load versus settlement (presently piles are not considered in the SCP-CDR (SNL, 1987)).
3. Required parameters for rock (these parameters will be developed from empirical relationships using rock mass classification data).
 - a. Indirect estimates of strength.
 - b. Indirect estimates of stiffness or Young's modulus.
4. Contingent parameters for rock.
 - a. Plate load bearing pressure vs. settlement (on the surface or down a borehole).
 - b. In situ direct shear test to measure the peak and residual shear strength of rock discontinuities.

The need for any contingent parameters will be determined by the soil or rock conditions encountered, the function or design requirements of the surface facilities, the types of foundations selected, and the type or sophistication of the analyses that are selected for the design or performance studies. On the basis of the known site conditions and the design presented in the SCP-CDR (SNL, 1987), these contingent parameters are not presently required. The contingent parameters will be characterized if unexpected soil and rock conditions are encountered, or if more sophisticated constitutive

CONSULTATION DRAFT

models are required or used in the soil or rock-structure interaction numerical codes.

Description

Standard field tests for geotechnical engineering practice will be conducted. Testing will be conducted only on soil and rock strata that will influence or be influenced by construction at the reference conceptual site. The type of test, location of test, and depth of test are dependent on factors like surface facility function, loads, type and depth of footings, and subsurface soil or rock conditions. If plate bearing or pile loading tests are conducted, they will be located in the immediate vicinity and in the same soil or rock strata as that of the proposed spread footing or pile. In addition, the confinement and moisture conditions of the test and the proposed foundation will also be similar. The results of these in situ loading tests will be extrapolated to estimate the bearing capacity or potential settlement of the larger proposed foundations. However, the in situ loading tests can be extrapolated only if properties of the soil or rock are uniform both laterally and with depth, otherwise potential deep-seated settlement resulting from the entire foundation loading will not be recognized from the results of the in situ loading test.

Indirect in situ methods can be used to estimate strength and stiffness in soils. The two most common methods are the Standard Penetration Test and the Dutch Cone Test. Both of these in situ methods are penetration resistance methods with the Standard Penetration Test applying an impact load and the Dutch Cone applying a continuous load. Another method has recently been developed called the Becker penetration resistance (Harder and Seed, 1986). It is recommended that this method be used in the gravelly soils at the site.

Preliminary estimates of rock mass strength and deformability will be made from empirical relationships with rock mass classification data. Hoek and Brown (1980) have attempted to relate Q and RMR rock mass classification values to failure criteria parameters they developed, which in turn can be related to Mohr-Coulomb failure criteria parameters. Rock mass deformation modulus was also empirically related to rock mass classification values by Bieniawski (1978).

The peak and residual strength of rock discontinuities will be evaluated in the field using in situ direct shear testing methods. This type of test will only be conducted if the site reconnaissance or preliminary exploration activities identify unfavorably oriented discontinuities in a potentially unstable rock slope that could result in a hazard to a critical safety-related structure like the waste handling facility.

Methods and technical procedures

Standard testing procedures will be used for Activity 8.3.1.14.2.3.3. A list of possible test methods are given in the following table.

CONSULTATION DRAFT

Method	Technical procedure		Date
	Number	Title	
Plate load settlement in soils or rock (use only if spread footings are considered in the design)	ASTM D1194-72	Standard test method for bearing capacity of soil for static load on spread footings	1977
Pile load settlement in soils (pile foundations are presently not considered in the SCP-CDR) ^a	ASTM D1143-81	Standard method of testing piles under static axial compressive load	1981
Plate load settlement in rock (Use only if spread footings are considered in the design)	ISRM, Part 2, pp. 148-154	Suggested method for field deformability determination using a plate test down a borehole	1978
In situ direct shear strength of rock discontinuity	ISRM, Doc. 1, Part 1	Suggested method for in situ determination of direct shear strength	Feb 74

^aSCP-CDR = Site Characterization Plan-Conceptual Design Report (SNL, 1987).

8.3.1.14.2.3.3 Activity: Geophysical field measurements

Objectives

Geophysical methods will be used to measure in situ soil and rock properties, profile the alluvium-bedrock contact, locate discontinuities or other structural abnormalities, and determine the depth, thickness, and lateral extent of soil and rock stratigraphic units. Geophysical methods provide a rapid and economical means of obtaining subsurface information and supplementing other facets of the exploration program. Geophysical measurements can be used to help set up detailed exploration programs (e.g., location, number, and depth of subsurface borings, trenches, and test pits), in addition to providing input for the evaluation of ground motion response and soil-structure interaction caused by earthquakes or underground nuclear events.

Developing an understanding of the seismic response of the ground surface and its interaction with surface facilities is important for siting and designing earthquake-resistant structures. To develop this understanding, it

is necessary to first identify the principal parameters that will control the seismic response of the ground surface. These parameters are the depth of the alluvium, the angle between the ground surface and the bedrock-alluvium interface, the seismic impedance contrast between the alluvium and bedrock, and the seismic absorptivity of the alluvium (Harmsen and Harding, 1981; Ohtsuke and Harumi, 1983; King and Tucker, 1984). These parameters will be used in addressing the repository design Issue 4.4 (Section 8.3.2.5) and for the preclosure tectonics investigation (Section 8.3.1.17.3) that evaluates ground motion caused by man-made or natural seismic events.

Parameters

The following data and parameters will be evaluated, collected, or both, to fulfill the objectives of this activity.

The measured or collected data for this activity are

1. Shear-wave velocities (three-dimensional model).
2. Compression-wave velocities (three-dimensional model).
3. Density (three-dimensional model).
4. Porosity.

The evaluated data for this activity are

1. Elastic Young's modulus.
2. Elastic shear modulus.
3. Damping.
4. Alluvium-bedrock contact depth and angle between the surface and the bedrock-alluvium interface.
5. Seismic impedance contrast between the alluvium and bedrock.
6. Location of discontinuities or other structural abnormalities.
7. Three-dimensional model of the soil and rock strata.

Description

Sufficient surface and borehole geophysical measurements will be conducted at the reference conceptual site and its vicinity such that three-dimensional models can be developed showing the subsurface geometry of the soil and rock strata and their corresponding dynamic material properties. Dynamic properties such as shear-wave and compression-wave velocities will be determined for alluvial material and bedrock beneath the reference conceptual site for the repository surface facilities and throughout Midway Valley, to a depth of 10-20 meters below the alluvium-bedrock contract. Information on subsurface seismic-wave transmission properties (velocities, densities, and damping) of the site is required by the preclosure tectonics investigation (Section 8.3.1.17.3) of potential ground motion caused by manmade or natural seismic events. If it is determined that a soil-structure or rock-structure

CONSULTATION DRAFT

interaction analysis will be required for facilities important to safety (e.g., waste handling building), then the shear-wave and compression-wave velocities will also be needed to determine the dynamic compression and shear moduli, and Poisson's ratio of the subsurface strata beneath the facilities important to safety.

Geophysical measurement methods can be categorized as either surface or borehole methods. Surface methods that will be applicable to this site and provide the required information consist of seismic refraction, electrical resistivity, and steady-state vibration. Borehole methods will consist of cross-hole seismic, up-hole and down-hole seismic, and borehole logging techniques. Borehole logging techniques will include neutron logging, gamma-gamma density logging, and acoustic or sonic logging.

Shallow seismic refraction methods can be used to determine depth of bedrock or the depth of a stratum with a substantially higher wave velocity. These methods are generally limited to depths of 1,000 ft (330 m) or less. Seismic refraction methods are most useful at sites where wave velocities in successive layers become greater with depth. For depths greater than 1,000 ft, seismic reflection methods will be used.

Electrical resistivity methods can be used to help determine the horizontal extent and depths of subsurface strata. These methods are only effective within the top 100 ft (30 m) of subsurface strata. The effectiveness of this method is influenced by the moisture content and salinity of the pore water within the soil and rock. The very low moisture content of the site's soils may limit its effectiveness.

Steady-state or continuous vibration methods are a valuable surface geophysical method for obtaining dynamic properties of the subsurface strata. The soil and rock properties that can be characterized with this method include wave velocities, natural period of vibration, damping characteristics, and dynamic modulus of subgrade reaction. These properties can be used to infer the type of subsurface strata and its depth and thickness and will be considerations in the siting and design of earthquake-resistant surface structures and foundations. The natural period of vibration is an important factor in the design of foundations subject to induced vibrations. Preliminary estimates of the allowable bearing capacity of soils can be made on the basis of empirical correlations with shear wave velocities or the natural period of vibration.

The cross-hole seismic method can be used to measure compressional and shear-wave velocities and damping characteristics of the subsurface strata. This method appears to be the best method for measuring in situ dynamic soil moduli (Woods, 1978). This method also allows for the measurement of velocity as a function of strain. Other advantages include the ability to identify and characterize lower velocity strata located below higher velocity strata. The disadvantage of this method is that it is more costly, requiring two or more boreholes that must be surveyed for vertical deviations. Considering the higher costs, the seismic refraction method may be preferred unless there is a need for strain-dependent velocities or the site is found to have lower velocity strata below higher velocity strata (e.g., a highly cemented layer of soil (caliche) above an uncemented or lightly cemented soil).

CONSULTATION DRAFT

Up-hole and down-hole seismic methods can also be used to measure compressional and shear-wave velocities. This method is cheaper than the cross-hole seismic method because it requires only one borehole. The disadvantage is that the properties of individual layers are determined with less certainty with this method because it measures average properties between the source and the recorder.

Geophysical borehole logging will provide estimates of physical properties of the soil and rocks in addition to correlating strata between boreholes and locating strata transitions or contacts. Gamma-gamma logs will provide estimates of the bulk density of the subsurface stratas. If used in combination with neutron and acoustic logs, gamma-gamma logs will indicate the presence and degree of fracturing in crystalline rock. Neutron logs can be used to correlate strata between boreholes and to approximate water content. When used in combination with the gamma-ray log, the neutron log provides a means for identifying lithologies and estimating porosity. Acoustic or sonic logs will be used to measure wave velocities and estimate porosity. The attenuation characteristics of compressional and shear waves may be correlated with the mechanical properties and degree of fracturing and fissuring of the formation.

Methods and technical procedures

Standard geophysical measurement methods will be used. A list of possible test methods follows:

1. Surface methods
 - a. Seismic refraction (Griffiths and King, 1965).
 - b. Electrical resistivity (LeRoy et al., 1977).
 - c. Steady-state vibration (Maxwell and Fry, 1967).
2. Borehole methods
 - a. Cross-hole seismic (Ballard and McLean, 1975).
 - b. Up-hole and down-hole seismic (Ballard and McLean, 1975).
 - c. Borehole logging (geophysical)
 - i. Neutron log (ISRM, 1981, Part 6, pp. 63-65).
 - ii. Gamma-gamma density log (ISRM, 1981, Part 7, pp. 65-66).
 - iii. Acoustic or sonic log (ISRM, 1981, Part 8, pp. 66-67).

It is not suggested that all these geophysical methods will be required. The selection of the appropriate methods will be determined by the site conditions that are encountered and the specific need for parameters such as strain-dependent moduli and damping.

8.3.1.14.2.4 Application of results

The information derived from this investigation will be used to support the following issues, site characterization investigations, and repository design and performance assessment information needs:

CONSULTATION DRAFT

<u>Information need, issue, or investigation</u>	<u>Description</u>
2.3.1	Determination of credible accidents applicable to the repository (Section 8.3.5.5.1).
2.7.1	Site information needed for design (Section 8.3.2.3.1).
4.2.1	Site and performance information needed for design (Section 8.3.2.4.1).
4.5	Total system costs--estimates of the cost of reference and alternative repository designs (Section 8.2.2.3.2.4). (Costs will be addressed during the environmental planning process.)
4.4.1	Site and performance assessment information needed for design, technical feasibility (Section 8.3.2.5.1).
8.3.1.17.3	Potential vibratory ground motion at the site from natural or manmade seismic sources.

Surface soil and rock characteristics will be important considerations in the siting, designing, and cost estimating of the surface facilities at the repository. Investigation 8.3.1.14.2 will provide part of the data required by Information Need 4.4.1 and Investigation 8.3.1.17.3. Soil and rock characteristics data pertinent to addressing potential natural hazards from earthquakes and slope instabilities will also be provided to Information Needs 2.3.1, 2.7.1, and 4.2.1 from Investigation 8.3.1.14.2.

8.3.1.14.2.5 Schedule and milestones

This investigation on soil and rock properties contains three out-year studies: 8.3.1.14.2.1 (exploration program), 8.3.1.14.2.2 (laboratory tests and material property measurements), and 8.3.1.14.2.3 (field tests and characterization measurements). The schedule information for these studies is presented in the form of timelines. The timelines extend from implementation of the approved study plans to the issuance of the final products associated with the study. Summary schedule information for this investigation can be found in Section 8.5.1.1.

Laboratory testing of material properties in Study 8.3.1.14.2.2 is constrained by the availability of core samples from existing test pits and boreholes and from new test pits and boreholes that will be developed as part of the exploration program in Study 8.3.1.14.2.1.

Material property data from Investigation 8.3.1.14.2 is required as input to Investigation 8.3.1.17.3 (studies to provide required information on vibratory ground motion that could affect repository design or performance). However, activities within these two investigations will be conducted in parallel and will interact in an iterative fashion. Data from the studies in

CONSULTATION DRAFT

Investigation 8.3.1.14.2 are also required input to design activities in Information Needs 4.4.1, 4.4.5, and 4.4.7 in Sections 8.3.2.5.1, 8.3.2.5.5, and 8.3.2.5.7, respectively. Activities within these information needs will be conducted in parallel with Investigation 8.3.1.14.2 and will interact in an iterative fashion.

The study numbers and titles corresponding to each timeline are shown on the left side of the following figure. The points on the timeline represent major events or important milestones associated with the study. Solid lines represent study durations, and dashed lines show interfaces. The data input and output at the interfaces are shown by circles.

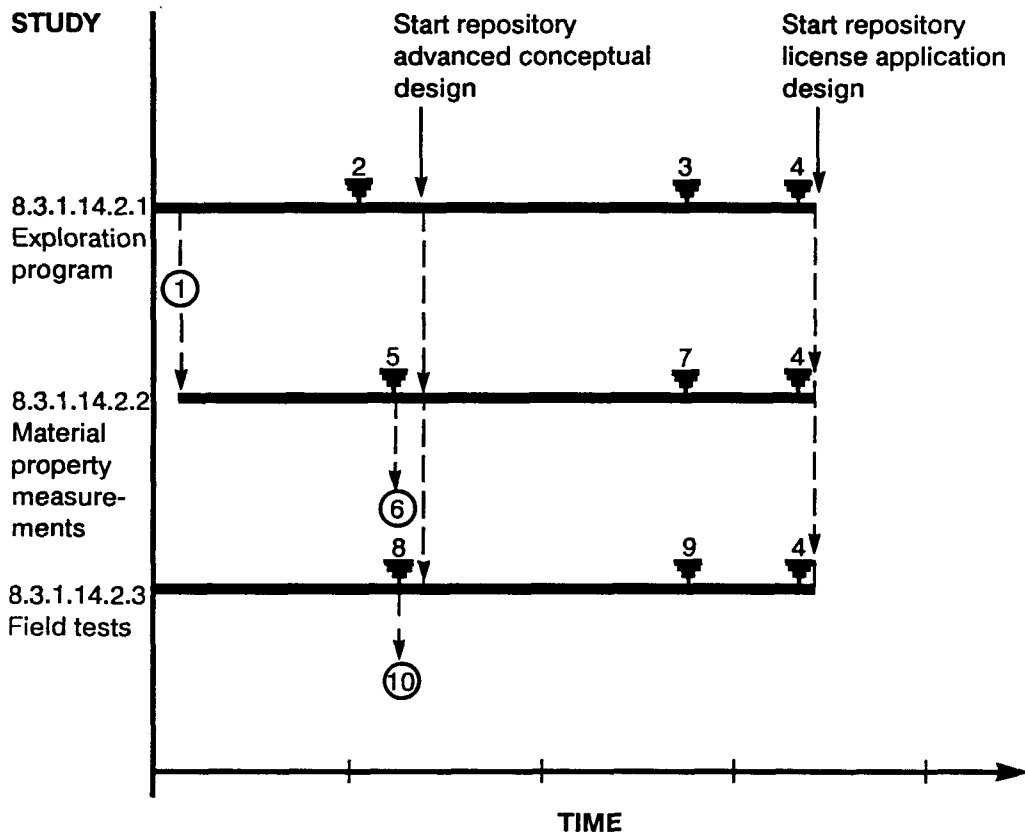

8311425-

The points on the timeline and the data input and output at the interfaces are described below:

<u>Point number</u>	<u>Description</u>
1	Soil and rock samples become available from existing test pits or boreholes or from new test pits or boreholes conducted in Study 8.3.1.14.2.1.

CONSULTATION DRAFT

<u>Point number</u>	<u>Description</u>
2	Milestone Z413. Issue a report on the results of the geotechnical exploration program for surface-facility advanced conceptual design (ACD) at Yucca Mountain.
3	Milestone Z416. Issue update report on the results of the geotechnical exploration program for surface-facility ACD at Yucca Mountain.
4	Milestone Q150. Issue a summary report on rock and soil properties at the reference conceptual site.
5	Milestone Z414. Issue a report on the results of the geotechnical laboratory tests and material property measurements for surface-facility ACD at Yucca Mountain.
6	Material property data input to Investigation 8.3.1.17.3 (vibratory ground motion).
7	Milestone Z417. Issue update report on the results of geotechnical laboratory tests and material property measurements for surface-facility ACD at Yucca Mountain.
8	Milestone Z415. Issue a report on the results of geotechnical field tests and characterization measurements for surface-facility ACD at Yucca Mountain.
9	Milestone Z418. Issue update report on the results of geotechnical field tests and characterization measurements for surface-facility ACD at Yucca Mountain.
10	Geophysical field measurement data to Investigation 8.3.1.17.3 (vibratory ground motion).

Nuclear Waste Policy Act
(Section 113)

Section 8.3.1.15

Consultation Draft

**THERMAL AND MECHANICAL
PROPERTIES**



Site Characterization Plan

***Yucca Mountain Site, Nevada Research
and Development Area, Nevada***

Volume V

January 1988

U.S. Department of Energy
Office of Civilian Radioactive Waste Management
Washington, DC 20585

CONSULTATION DRAFT

**8.3.1.15 Overview of thermal and mechanical rock properties program:
Description of thermal and mechanical rock properties required by the performance and design issues**

Summary of performance and design requirements for thermal and mechanical rock properties information

This program provides all site information needed on thermal and mechanical rock properties and on ambient stress and temperature conditions. The requests for this information can be summarized as follows:

<u>Data required</u>	<u>Issue</u>	<u>Short title</u>	<u>SCP section</u>
Thermal properties of host rock for analyses related to waste package design	1.10	Waste package characteristics (postclosure)	8.3.4.2
Thermal/mechanical properties of the rock for repository design and in situ stress and temperature conditions for initial and boundary conditions for design calculations	1.11	Configuration of underground facilities (postclosure)	8.3.2.2
	1.12	Seal characteristics	8.3.3.2
	4.4	Preclosure design and technical feasibility	8.3.2.5
Thermal properties of rock for disturbed zone analysis	1.6	Ground-water travel time	8.3.5.12
Bulk properties and radon emanation rate for radiologic safety analysis	2.7	Repository design criteria for radiological safety	8.3.2.3

Table 8.3.1.15-1 summarizes the required rock characteristics information and outlines the tie to this section's site characterization activities, which describe how the data will be obtained. The parameters to be measured may be different from those requested in the table. The reasons for the differences and the techniques to be used to produce required data from measured data are described in later portions of Section 8.3.1.15.

Table 8.3.1.15-1. Performance and design parameters, tentative goals, and characterization parameters for thermal and mechanical properties program^a (page 1 of 12)

Issue request ing parameter (SCP section)	Performance or design parameter	Material type and spatial location ^b	Strati- graphic loca- tion ^c	Tentative goal ^{c,d,e}	Needed confi- dence ^{c,d}	Current estimate ^c	Current confi- dence ^{c,d}	Parameter to be measured	Material type tested	SCP activity numbers	Spatial loca- tion	Strati- graphic loca- tion ^b
1 6 (8 3 5 12)	Bulk density	Rock mass, primary area	NS	NS	NS	NS	NS	Grain den- sity, porosity	Intact rock	8 3 1 15 1 1 1	(g)	NS
1 10 (8 3 4 2)	Bulk density	Rock mass, primary area	TSw2	$\bar{x} \pm 0.1x$	Medium	NS	Low to medium	Grain den- sity, porosity	Intact rock	8 3 1 15 1 1 1	(g)	TSw2
2 7 (8 3 2 3)	Bulk density	Rock mass, primary area	TSw2	(f)	Medium to high	2 26 2 33 g/cm ³	Low to medium	Grain den- sity, porosity	Intact rock	8 3 1 15 1 1 1	(g)	TSw2
1 6 (8 3 5 12)	Thermal conductivity	Rock mass, primary area	NS	NS	NS	NS	NS	Thermal con- ductivity of solids, porosity	Intact rock	8 3 1 15 1 1 1 8 3 1 15 1 1 3	(g)	NS
								Thermal con- ductivity	Rock mass	8 3 1 15 1 6 2 8 3 1 15 1 6 3 8 3 1 15 1 6 5	ESF	TSw2
1 10 (8 3 4 2)	Thermal conductivity	Intact rock, primary area	TSw2	$\bar{x} \pm 0.1x$	Medium	NS	Low to medium	Thermal con- ductivity of solids, porosity	Intact rock	8 3 1 15 1 1 1 8 3 1 15 1 1 3	(g)	TSw2
	Thermal conductivity	Rock mass, primary area	TSw2	$\bar{x} \pm 0.1x$	Medium	NS	Low to medium	Thermal con- ductivity	Rock mass	8 3 1 15 1 6 2 8 3 1 15 1 6 3 8 3 1 15 1 6 5	ESF	TSw2
1 11 (8 3 2 2)	Thermal conductivity	Rock mass, primary area and exten- sions	TSw2	$\bar{x} \pm 0.2x$	High	See Table 6 16	Low to medium	Thermal con- ductivity of solids, porosity	Intact rock	8 3 1 15 1 1 1 8 3 1 15 1 1 3	(g)	TSw2
								Thermal con- ductivity	Rock mass	8 3 1 15 1 6 2 8 3 1 15 1 6 3 8 3 1 15 1 6 5	ESF	TSw2
			TSw1	$\bar{x} \pm 0.2x$	Medium	See Table 6 16	Low to medium	Thermal con- ductivity of solids, porosity	Intact rock	8 3 1 15 1 1 1 8 3 1 15 1 1 3	(g)	TSw1
								Thermal con- ductivity	Rock mass	8 3 1 15 1 6 1	ESF	TSw1

8.3.1.15-2

CONSULTATION DRAFT

Table 8.3.1.15-1. Performance and design parameters, tentative goals, and characterization parameters for thermal and mechanical properties program (page 2 of 12)

Issue requesting parameter (SCP section)	Performance or design parameter	Material type and spatial location ^b	Stratigraphic location ^c	Tentative goal ^{c,d,e}	Needed confidence ^{c,d}	Current estimate ^c	Current confidence ^{c,d}	Parameter to be measured	Material type tested	SCP activity numbers	Spatial location	Stratigraphic location ^b
1 11 (8 3 2 2) (continued)			TSw3, CHn1	$\bar{x} \pm 0.2x$	Medium	See Table 6 16	Low to medium	Thermal conductivity of solids, porosity	Intact rock	8 3 1 15 1 1 1 8 3 1 15 1 1 3	(g)	TSw3 CHn1
			Units above TSw1, CHn2	$\bar{x} \pm 0.2\bar{x}$	Low	See Table 6 16	Low to medium	Thermal conductivity of solids, porosity	Intact rock	8 3 1 15 1 1 1 8 3 1 15 1 1 3	(g)	(h)
1 12 (8 3 3 2)	Thermal conductivity	Rock mass, primary area	TSw2, CHn1	NS	Medium	NS	Low to medium	Thermal conductivity of solids, porosity	Intact rock	8 3 1 15 1 1 1 8 3 1 15 1 1 3	(g)	TSw2, CHn1
									Thermal conductivity	Rock mass	8 3 1 15 1 6 2 8 3 1 15 1 6 3 8 3 1 15 1 6 5	ESF
4 4 (8 3 2 5)	Thermal conductivity	Rock mass, primary area	TSw2	$\bar{x} \pm 0.2\bar{x}$	Medium	\bar{x}	Low to medium	Thermal conductivity of solids, porosity	Intact rock	8 3 1 15 1 1 1 8 3 1 15 1 1 3	(g)	TSw2
									Thermal conductivity	Rock mass	8 3 1 15 1 6 2 8 3 1 15 1 6 3 8 3 1 15 1 6 5	ESF
			TSw1	$\bar{x} \pm 0.2x$	Medium	\bar{x}	Low to medium	Thermal conductivity of solids, porosity	Intact rock	8 3 1 15 1 1 1 8 3 1 15 1 1 3	(g)	TSw1
								Thermal conductivity	Rock mass	8 3 1 15 1 6 1	ESF	TSw1
	Thermal conductivity	Rock mass, primary area	Ground surface to base of TSw2	$x \pm 0.2\bar{x}$	Low	\bar{x}	Low to medium	Thermal conductivity of solids, porosity	Intact rock	8 3 1 15 1 1 1 8 3 1 15 1 1 3	(g)	Alluvium, TCw, PTn, TSw1, TSw2
								Thermal conductivity	Rock mass	8 3 1 15 1 6 1 8 3 1 15 1 6 2 8 3 1 15 1 6 3 8 3 1 15 1 6 5	ESF	TSw1, TSw2

8.3.1.15-3

CONSULTATION DRAFT

Table 8.3.1.15-1. Performance and design parameters, tentative goals, and characterization parameters for thermal and mechanical properties program (page 3 of 12)

Issue request ing parameter (SCP section)	Performance or design parameter	Material type and spatial location ^b	Strati- graphic loca- tion ^c	Tentative goal ^{c,d,e}	Needed confi- dence ^{c,d}	Current estimate ^c	Current confi- dence ^{c,d}	Parameter to be measured	Material type tested	SCP activity numbers	Spatial loca- tion	Strati- graphic loca- tion ^b
1 6 (8 3 5 12)	Heat capacity	Rock mass, primary area	NS	NS	NS	NS	NS	Heat capacity of solids, grain density, porosity	Intact rock	8 3 1 15 1 1 1 8 3 1 15 1 1 2	(g)	NS
								Heat capacity	Rock mass	8 3 1 15 1 6 2 8 3 1 15 1 6 3 8 3 1 15 1 6 5	ESF	TSw2
1 10 (8 3 4 2)	Heat capacity	Intact rock, primary area	TSw2	x + 0 2 x	Medium	x	Low to Medium	Heat capacity of solids, grain density, porosity	Intact rock	8 3 1 15 1 1 1 8 3 1 15 1 1 2	(g)	TSw2
								Heat capacity	Rock mass	8 3 1 15 1 6 2 8 3 1 15 1 6 3 8 3 1 15 1 6 5	ESF	TSw2
1 11 (8 3 2 2)	Heat capacity	Rock mass, primary area and exten- sions	TSw2	x + 0 1x	High	See Table 6 16	Low to medium	Heat capacity of solids, grain density, porosity	Intact rock	8 3 1 15 1 1 1 8 3 1 15 1 1 2	(g)	TSw2
								Heat capacity	Rock mass	8 3 1 15 1 6 2 8 3 1 15 1 6 3 8 3 1 15 1 6 5	(g)	TSw2
								Heat capacity	Rock mass	8 3 1 15 1 6 1	ESF	TSw1
			TSw1	x ± 0 1x	Medium	See Table 6 16	Low to medium	Heat capacity of solids, grain density, porosity	Intact rock	8 3 1 15 1 1 1 8 3 1 15 1 1 2	(g)	TSw1
			TSw3 CHn1	x + 0 1x	Medium	See Table 6 16	Low to medium	Heat capacity of solids, grain den- sity, porosity	Intact rock	8 3 1 15 1 1 1 8 3 1 15 1 1 2	(g)	TSw3, CHn1
All units above TSw1, CHn2	x + 0 1x	Low	See Table 6 16	Low	Heat capacity of solids grain den- sity, porosity	Intact rock	8 3 1 15 1 1 1 8 3 1 15 1 1 2	(g)	(f)			
1 12 (8 3 3 2)	Heat capacity	Rock mass primary area	TSw2 CHn1	NS	Medium	NS	Low to medium	Heat capacity of solids grain density, porosity	Intact rock	8 3 1 15 1 1 1 8 3 1 15 1 1 2	(g)	TSw2 CHn1
								Heat capacity	Rock	8 3 1 15 1 6 2	ESF	TSw2

8.3.1.15-4

CONSULTATION DRAFT

Table 8.3.1.15-1. Performance and design parameters, tentative goals, and characterization parameters for thermal and mechanical properties program² (page 4 of 12)

Issue requesting parameter (SCP section)	Performance or design parameter	Material type and spatial location	Stratigraphic location ^c	Tentative goal ^{c,d,e}	Needed confidence ^{c,d}	Current estimate ^c	Current confidence ^{c,d}	Parameter to be measured	Material type tested	SCP activity numbers	Spatial location	Stratigraphic location ^b
4 4 (8 3 2 5)	Heat capacity	Rock mass, primary area	TSw2	$\bar{x} \pm 0.1\bar{x}$	Medium	\bar{x}	Low to medium	Heat capacity of solids, grain density, porosity	Intact rock	8 3 1 15 1 1 1 8 3 1 15 1 1 2	(g)	TSw2
								Heat capacity	Rock mass	8 3 1 15 1 6 2 8 3 1 15 1 6 3 8 3 1 15 1 6 5	ESF	TSw2
4 4 (8 3 2 5) (continued)	Heat capacity	Rock mass, primary area	TSw1	$\bar{x} \pm 0.1\bar{x}$	Medium	\bar{x}	Low to medium	Heat capacity of solids, grain density, porosity	Intact rock	8 3 1 15 1 1 1 8 3 1 15 1 1 2	(g)	TSw1
								Heat capacity	Rock mass	8 3 1 15 1 6 1	ESF	TSw1
1 6 (8 3 5 12)	Coefficient of thermal expansion	Rock mass, primary area	Ground surface to base of TSw2	$\bar{x} \pm 0.1\bar{x}$	Low	\bar{x}	Low to medium	Heat capacity of solids, grain density, porosity	Intact rock	8 3 1 15 1 1 1 8 3 1 15 1 1 2	(g)	Alluvium, TCw, PTn, TSw1, TSw2
								Heat capacity	Rock mass	8 3 1 15 1 6 1 8 3 1 15 1 6 2 8 3 1 15 1 6 3 8 3 1 15 1 6 5	TSw1, TSw2	
1 11 (8 3 2 2)	Coefficient of thermal expansion	Rock mass, primary area and extensions	NS	NS	NS	NS	NS	Coefficient of thermal expansion	Intact rock	8 3 1 15 1 2 1	(g)	NS
								Coefficient of thermal expansion	Rock mass	8 3 1 15 1 6 2 8 3 1 15 1 6 3 8 3 1 15 1 6 4 8 3 1 15 1 6 5	ESF	TSw2
1 11 (8 3 2 2)	Coefficient of thermal expansion	Rock mass, primary area and extensions	TSw2	$\bar{x} \pm 0.15\bar{x}$	High	See Table 6 16	Medium	Coefficient of thermal expansion	Intact rock	8 3 1 15 1 2 1	(g)	TSw2
								Coefficient of thermal expansion	Rock mass	8 3 1 15 1 6 2 8 3 1 15 1 6 3 8 3 1 15 1 6 4 8 3 1 15 1 6 5	ESF	TSw2
1 11 (8 3 2 2)	Coefficient of thermal expansion	Rock mass, primary area and extensions	TSw1	$\bar{x} \pm 0.15\bar{x}$	Medium	See Table 6 16	Low to medium	Coefficient of thermal expansion	Intact rock	8 3 1 15 1 2 1	(g)	TSw1
								Coefficient of thermal expansion	Rock mass	8 3 1 15 1 6 1	ESF	TSw1

8.3.1.15-5

CONSULTATION DRAFT

Table 8.3.1.15-1. Performance and design parameters, tentative goals, and characterization parameters for thermal and mechanical properties program^a (page 5 of 12)

Issue requesting parameter (SCP section)	Performance or design parameter	Material type and spatial location ^b	Stratigraphic location ^c	Tentative goal ^{c,d,e}	Needed confidence ^{c,d}	Current estimate ^c	Current confidence ^{c,d}	Parameter to be measured	Material type tested	SCP activity numbers	Spatial location	Stratigraphic location ^b	
1 11 (8 3 2 2) (continued)			TSw3, CHn1	$\bar{x} \pm 0.15\bar{x}$	Medium	See Table 6-16	Low to medium	Coefficient of thermal expansion	Intact rock	8 3 1 15 1 2 1	(g)	TSw3, CHn1	
			All units above TSw1, CHn2	$\bar{x} \pm 0.15\bar{x}$	Low	See Table 6-16	Low to medium	Coefficient of thermal expansion	Intact rock	8 3 1 15 1 2 1	(g)	(h)	
1 12 (8 3 3 2)	Coefficient of thermal expansion	Rock mass, primary area	TSw2, CHn1	NS	Medium	NS	Low to medium	Coefficient of thermal expansion	Intact rock	8 3 1 15 1 2 1	(g)	TSw2, CHn1	
								Coefficient of thermal expansion	Rock mass	8 3 1 15 1 6 2 8 3 1 15 1 6 3 8 3 1 15 1 6 4 8 3 1 15 1 6 5	ESF	TSw2	
4 4 (8 3 2 5)	Coefficient of thermal expansion	Rock mass, primary area	TSw2	$\bar{x} \pm 0.15\bar{x}$	Medium	\bar{x}	Medium	Coefficient of thermal expansion	Intact rock	8 3 1 15 1 2 1	(g)	TSw2	
								Coefficient of thermal expansion	Rock mass	8 3 1 15 1 6 2 8 3 1 15 1 6 3 8 3 1 15 1 6 4 8 3 1 15 1 6 5	ESF	TSw2	
1 11 (8 3 2 2)	Elastic properties	Intact rock, primary area and extensions	TSw2	$\bar{x} \pm 0.15\bar{x}$	High	See Table 6-12	Medium	Young's modulus	Intact rock	8 3 1 15 1 3 1 8 3 1 15 1 3 2	(g)	TSw2	
			TSw1	$\bar{x} \pm 0.15\bar{x}$	Medium	See Table 6-12	Medium	Young's modulus	Intact rock	8 3 1 15 1 3 1 8 3 1 15 1 3 2	(g)	TSw1	
			TSw3, CHn1	$\bar{x} \pm 0.15\bar{x}$	Medium	See Table 6-12	Low	Young's modulus	Intact rock	8 3 1 15 1 3 1 8 3 1 15 1 3 2	(g)	TSw3, CHn1	
			All units above TSw1, CHn2	$\bar{x} \pm 0.15\bar{x}$	Low	See Table 6-12	Low to medium	Young's modulus	Intact rock	8 3 1 15 1 3 1 8 3 1 15 1 3 2	(g)	(h)	

8.3.1.15-6

CONSULTATION DRAFT

Table 8.3.1.15-1. Performance and design parameters, tentative goals, and characterization parameters for thermal and mechanical properties program (page 6 of 12)

Issue requesting parameter (SCP section)	Performance or design parameter	Material type and spatial location ^b	Stratigraphic location ^c	Tentative goal ^{c,d,e}	Needed confidence ^{c,d}	Current estimate ^c	Current confidence ^{c,d}	Parameter to be measured	Material type tested	SCP activity numbers	Spatial location	Stratigraphic location ^b			
1 11 (8 3 2 2) (continued)	Deformation modulus	Rock mass, primary area and extensions	TSw2	$\bar{x} \pm 0.15\bar{x}$	High	See Table 6-14	Low	Young's modulus, fracture stiffness	Intact rock and fractures	8 3 1 15 1 3 1 8 3 1 15 1 3 2 8 3 1 15 1 4 1 8 3 1 15 1 4 2	(g)	TSw2			
										Deformation modulus	Rock mass	8 3 1 15 1 6 3 8 3 1 15 1 7 1	ESF	TSw2	
			TSw1	$\bar{x} \pm 0.15\bar{x}$	Medium	See Table 6-14	Low	Young's modulus, fracture stiffnesses	Intact rock and fractures	8 3 1 15 1 3 1 8 3 1 15 1 3 2 8 3 1 15 1 4 1 8 3 1 15 1 4 2	(g)	TSw1			
						TSw3, CHn1	$\bar{x} \pm 0.15\bar{x}$	Medium	See Table 6 14	Low	Young's modulus, fracture stiffness	Intact rock and fractures	8 3 1 15 1 3 1 8 3 1 15 1 3 2 8 3 1 15 1 4 1 8 3 1 15 1 4 2	(g)	TSw3, CHn1
			All units above TSw1, CHn2	$\bar{x} \pm 0.15\bar{x}$	Low	See Table 6 14	Low	Young's modulus, fracture stiffness	Intact rock & fractures	8 3 1 15 1 3 1 8 3 1 15 1 3 2 8 3 1 15 1 4 1 8 3 1 15 1 4 2	(g)	(h)			
	Poisson's ratio	Intact rock, primary area and extensions	TSw2	$\bar{x} \pm 0.2\bar{x}$	Medium	See Table 6 12	Medium	Poisson's ratio	Intact rock	8 3 1 15 1 3 1 8 3 1 15 1 3 2	(g)	TSw2			
			All units other than TSw2	$\bar{x} \pm 0.2\bar{x}$	Low	See Table 6 12	Low to medium	Poisson's ratio	Intact rock	8 3 1 15 1 3 1 8.3 1.15 1 3 2	(g)	(h)			
4 4 (8 3 2 5)	Elastic properties	Intact rock, primary area	TSw2	20 33 GPa	Medium	31 GPa	Medium	Young's modulus	Intact rock	8 3 1 15 1 3 1 8 3 1 15.1 3 2	(g)	TSw2			
			TSw1	Nonlitho physal 12 54 GPa	Medium	Nonlitho physal 19 44 GPa	Medium						Young's modulus	Intact rock	8 3 1 15 1 3 1 8 3 1 15 1 3 2

8.3.1.15-7

CONSULTATION DRAFT

Table 8.3.1.15-1. Performance and design parameters, tentative goals, and characterization parameters for thermal and mechanical properties program^a (page 7 of 12)

Issue request ing parameter (SCP section)	Performance or design parameter	Material type and spatial location ^b	Strati-graphic loca-tion ^c	Tentative goal ^{c,d,e}	Needed confi-dence ^{c,d}	Current estimate ^c	Current confi-dence ^{c,d}	Parameter to be measured	Material type tested	SCP activity numbers	Spatial loca-tion	Strati-graphic loca-tion ^b		
4 4 (8 3 2 5) (continued)	Deformation modulus	Rock mass, primary area	TSw2	Lithophy-sal 14-17 GPa	Medium	Lithophy-sal 15.5 GPa	Low	Young's modulus						
				11-19 GPa	Medium	11.19 GPa	Low	Young's modulus, fracture stiffnesses	Intact rock & frac-tures	8 3 1 15 1 3 1 8 3 1 15 1 3 2 8 3 1 15 1 4 1 8 3 1 15 1 4 2	(g)	TSw2		
								Deformation modulus	Rock mass	8 3 1 15 1 6 3 8 3 1 15 1 7 1 8 3 1 15 2 1 2	ESF	TSw2		
			TSw1	Nonlitho-physal 12-20 GPa	Medium	Nonlitho-physal 12-20 GPa	Low	Young's modulus, fracture stiffnesses	Intact rock & frac-tures	8 3 1 15 1 3 1 8 3 1 15 1 3 2 8 3 1 15 1 4 1 8 3 1 15 1 4 2	(g)	TSw1		
				Lithophy-sal 4.11 GPa	Medium	Lithophy-sal 4.11 GPa	Low							
								Deformation modulus	Rock mass	8 3 1 15 1 3 1	ESF	TSw1		
	Poisson's ratio	Intact rock, primary area	TSw2	0.19-0.29	Medium	0.19-0.29	Medium	Poisson's ratio	Intact rock	8 3 1 15 1 3 1 8 3 1 15 1 3 2	(g)	TSw1		
				TSw1	Nonlitho-physal 0.20-0.30 GPa	Low	Nonlitho-physal 0.20-0.30 GPa	Low to medium	Poisson's ratio	Intact rock	8 3 1 15 1 3 1 8 3 1 15 1 3 2	(g)	TSw1	
				Litho-physal 0.13-0.19	Low	Litho-physal 0.13-0.19	Low							
	1 11 (8 3 2 2)	Compressive strength	Intact rock, primary area and extensions	TSw2	$\bar{x} \pm 0.2\bar{x}$	High	See Table 6.12	Medium	Compressive strength	Intact rock	8 3 1 15 1 3 1 8 3 1 15 1 3 2	(g)	TSw2	
					TSw1	$\bar{x} \pm 0.2\bar{x}$	High	See Table 6.12	Medium	Compressive strength	Intact rock	8 3 1 15 1 3 1 8 3 1 15 1 3 2	(g)	TSw1
	Cohesion and angle of internal friction	Intact rock, primary area and extensions	Units above TSw1 and below TSw2	$\bar{x} \pm 0.2\bar{x}$	Medium	See Table 6.12	Low to medium	Compressive strength	Intact rock	8 3 1 15 1 3 1 8 3 1 15 1 3 2	(g)	(h)		

8.3.1.15-8

CONSULTATION DRAFT

Table 8.3.1.15-1. Performance and design parameters, tentative goals, and characterization parameters for thermal and mechanical properties program (page 8 of 12)

Issue requesting parameter (SCP section)	Performance or design parameter	Material type and spatial location ^b	Stratigraphic location ^c	Tentative goal ^{c,d,e}	Needed confidence ^{c,d}	Current estimate ^c	Current confidence ^{c,d}	Parameter to be measured	Material type tested	SCP activity numbers	Spatial location	Stratigraphic location ^b
1.11 (8.3.2.2) (continued)	Unconfined compressive strength	Intact rock, primary area and extensions	Units above TS _{w1} and below TS _{w2}	$x + 0.15x$	Low	See Table 6.12	Low to medium	Unconfined compressive strength	Intact rock	8.3.1.15.1.3.1	(g)	(f)
1.12 (8.3.3.2)	Unconfined compressive strength	Rock mass, shaft and ramp locations	TC _w	$x + 0.2x$	Medium	See Table 6.12	Low	Compressive strength	Intact rock	8.3.1.15.1.3.1 8.3.1.15.1.3.2	(g)	TC _w
	Unconfined compressive strength	Rock mass, primary area	CH _{n1}	$x + 0.2x$	Medium	See Table 6.12	Low	Compressive strength	Intact rock	8.3.1.15.1.3.1 8.3.1.15.1.3.2	(g)	CH _{n1}
	Unconfined compressive strength	Rock mass, primary area	TS _{w2}	$x + 0.2x$	Medium	See Table 6.12	Low	Unconfined compressive strength	Intact rock	8.3.1.15.1.3.1 8.3.1.15.1.3.2	(g)	TS _{w2}
4.4 (8.3.2.5)	Compressive strength	Intact rock, primary area	TS _{w1} , TS _{w2}	TS _{w1} , non lithophysical 54.207 MPa	Medium	67.172 MPa	Medium	Unconfined compressive strength	Intact rock	8.3.1.15.1.3.1 8.3.1.15.1.3.2	(g)	TS _{w1} , TS _{w2}
				TS _{w1} , lithophysical 13.19 MPa	Medium	16 MPa	Medium	Compressive strength				
				TS _{w2} 121.175 MPa	Medium	148 MPa	Medium	Unconfined compressive strength				
	Unconfined compressive strength	Intact rock, primary area	TC _w , PT _n	$x + 0.2x$	Medium	x	Low to medium	Unconfined compressive strength	Intact rock	8.3.1.15.1.3.1 8.3.1.15.1.3.2	(g)	TC _w , PT _n
	Cohesion and angle of internal friction	Intact rock, primary area	TC _w , PT _n	$x + 0.2x$	Medium	x	Low to medium	Compressive strength	Intact rock	8.3.1.15.1.3.1 8.3.1.15.1.3.2	(g)	TC _w , PT _n , TS _{w1} , TS _{w2}

8.3.1.15-9

CONSULTATION DRAFT

Table 8.3.1.15-1. Performance and design parameters, tentative goals, and characterization parameters for thermal and mechanical properties program^a (page 9 of 12)

Issue request ing parameter (SCP section)	Performance or design parameter	Material type and spatial location ^b	Strati- graphic loca- tion ^c	Tentative goal ^{c,d,e}	Needed confi- dence ^{c,d}	Current estimate ^c	Current confi- dence ^{c,d}	Parameter to be measured	Material type tested	SCP activity numbers	Spatial loca- tion	Strati- graphic loca- tion ^b
1 11 (8 3 2 2)	Mechanical pro- perties of fractures											
	Cohesion and coefficient of friction	Fractures, pri- mary area and extensions	Units above TSw1 and below TSw2	$\bar{x} \pm 0.15\bar{x}$	Medium	See Table 6 13	Low	Shear stress at onset of slip	Fractures	8 3 1 15 1 4 1 8 3 1 15 1 4 2	(g)	(h)
1 11 (8 3 2 2) (continued)	Large scale- joint strength	Fractures, pri- mary area	TSw1, TSw2	$\bar{x} \pm 0.2\bar{x}$	High	NS	Low	Shear stress at onset of slip	Fractures	8 3 1 15 1 4 1 8 3 1 15 1 4 2	(g)	TSw1, TSw2
	Normal and shear stiff- nesses	Fractures, pri- mary area and extensions	TSw2	See Table 6-13	Medium	NS	Low	Normal and shear stiff- nesses	Fractures	8 3 1 15 1 4 1 8 3 1 15 1 4 2	(g)	TSw2
			TSw1, TSw3, CHn1	See Table 6 13	Low	NS	Low	Normal and shear stiff- nesses	Fractures	8 3 1 15 1 4 1 8 3 1 15 1 4 2	(g)	(h)
4 4 (8 3 2 5)	Mechanical pro- perties of fractures											
	Cohesion and coefficient of friction	Fractures, pri- mary area	TSw2	$\bar{x} \pm 0.2\bar{x}$	Medium	\bar{x}	Low	Shear stress at onset of slip	Fractures	8 3 1 15 1 4 1 8 3 1 15 1 4 2	(g)	TSw2
	Normal and shear stiff- nesses	Fractures, pri- mary area	TSw2	NS	Medium	NS	Low	Normal and shear stiff- nesses	Fractures	8 3 1 15 1 4 1 8 3 1 15 1 4 2	(g)	TSw2
2 7 (8 3 2 3)	Radon emanation rate	Rock mass, primary area	TSw2	(f)	High	0.48 pCi/m ² s	Low	Radon emana- tion rate	Rock mass	8 3 1 15 1 6 2	ESF	TSw2
4 4 (8 3 2 5)	Radon emanation rate	Rock mass, primary area	TSw2	(f)	Medium	NS	Low	Radon emana- tion rate	Rock mass	8 3 1 15 1 6 2	ESF	TSw2
1 11 (8 3 2 2)	Empirical design parameters											
	Joint wall compressive strength	Fracture sur- faces, primary area	TSw2	See Table 6 15	Medium	NS	Low	Joint wall compressive strength	Fracture sur- faces	8 3 1 15 1 6 3 8 3 1 15 1 7 1	ESF	TSw2

8.3.1.15-10

CONSULTATION DRAFT

Table 8.3.1.15 1. Performance and design parameters, tentative goals, and characterization parameters for thermal and mechanical properties program² (page 10 of 12)

Issue requesting parameter (SCP section)	Performance or design parameter	Material type and spatial location ^b	Stratigraphic location ^c	Tentative goal ^{c,d,e}	Needed confidence ^{c,d}	Current estimate ^c	Current confidence ^{c,d}	Parameter to be measured	Material type tested	SCP activity numbers	Spatial location	Stratigraphic location ^b
1 11 (8 3 2 2) (continued)			TSw1, TSw3, CHn1	See Table 6-15	Low	NS	Low	Joint wall compressive strength	Fracture surfaces	NS	(g)	(h)
	Joint roughness coefficient	Fracture surfaces, primary area	TSw2	See Table 6-15	Medium	NS	Low	Joint roughness coefficient	Fracture surfaces	8 3 1 15 1 6 3 8 3 1 15 1 7 1	ESF	TSw2
			TSw1, TSw3, CHn1	See Table 6-15	Low	NS	Low	Joint wall compressive strength	Fracture surfaces	NS	(g)	(h)
4 4 (8 3 2 5)	Empirical design parameters											
	Joint wall compressive strength	Fracture surfaces, primary area	TSw2	See Table 6-15	Medium	NS	Low	Joint wall compressive strength	Fracture surfaces	8 3 1 15 1 6 3 8 3 1 15 1 7 1	ESF	TSw2
	Joint roughness coefficient	Fracture surfaces, primary area	TSw2	See Table 6-15	Medium	NS	Low	Joint roughness coefficient	Fracture surfaces	8 3 1 15 1 6 3 8 3 1 15 1 7 1	ESF	TSw2
1 11 (8 3 2 2)	In situ stress state ¹											
	σ_v	Rock mass, primary area and extensions	Ground surface to water table	± 1 MPa	Medium	(ρgh) ¹	Low to medium	Grain density, porosity	Intact rock	8 3 1 15 1 1 1	(g)	Alluvium, TCw, PTn, TSw1, TSw2, TSw3, CHn1, CHn2
	σ_h, σ_H	Rock mass, primary area and extensions	Ground surface to water table	± 2 MPa	Medium	NS	Low	Deformation, elastic properties	Intact rock	8 3 1 15 2 1 1	(g)	TSw2
1 12 (8 3 3 2)	In situ stress state											
	σ_v	Rock mass, primary area	TCw, TSw2, CHn1	\pm MPa	Low	4-10 MPa	Low to medium	Grain density, porosity	Intact rock	8 3 1 15 1 1 1	(g)	Alluvium, TCw, PTn, TSw1, TSw2, TSw3, CHn1

8.3.1.15-11

CONSULTATION DRAFT

Table 8.3.1.15-1. Performance and design parameters, tentative goals, and characterization parameters for thermal and mechanical properties program^a (page 11 of 12)

Issue requesting parameter (SCP section)	Performance or design parameter	Material type and spatial location ^b	Stratigraphic location ^c	Tentative goal ^{c,d,e}	Needed confidence ^{c,d}	Current estimate ^c	Current confidence ^{c,d}	Parameter to be measured	Material type tested	SCP activity numbers	Spatial location	Stratigraphic location ^b
1 12 (8 3 3 2) (continued)	σ_h, σ_H	Rock mass, primary area	TCw, TSw2, CHn1	± 2 MPa	Low	$\sigma_h/\sigma_v, \sigma_H/\sigma_v = 0.3-1.0$	Low	Deformation, elastic properties	Intact rock	8 3 1 15 2 1 1 8 3 1 15 2 1 2	(g)	TCw, TSw2, CHn1
4 4 (8 3 2 5)	In situ stress state											
	σ_v	Rock mass, primary area	TSw2	300 m depth 6 3-7 7 MPa	Medium	(6 3 7 7 MPa)	Low to medium	Grain density, porosity	Intact rock	8 3 1 15 1 1 1	(g)	Alluvium, TCw, PTn, TSw1, TSw2
	σ_n/σ_v	Rock mass, primary area	TSw2	0 3-0 8	Medium	0 3-0 8	Low	Deformation, elastic properties	Intact rock	8 3 1 15 2 1 1 8 3 1 15 2 1 2	(g)	TSw2
	σ_H/σ_v	Rock mass, primary area	TSw2	0 3 1 0	Medium	0 3-1 0	Low	Deformation, elastic properties	Intact rock	8 3 1 15 2 1 1 8 3 1 15 2 1 2	(g)	TSw2
	Bearing of σ_h	Rock mass, primary area	TSw2	N 45°W- N 65°W	Medium	N 45°W- N 65°W	Medium	Deformation, elastic properties	Intact rock	8 3 1 15 2 1 1 8 3 1 15 2 1 2	(g)	TSw2
	Bearing of σ_H	Rock mass, primary area	TSw2	N 25°E- N 40°E	Medium	N 25°E- N 40°E	Medium	Deformation, elastic properties	Intact rock	8 3 1 15 2 1 1 8 3 1 15 2 1 2	(g)	TSw2
1 6 (8 3 5 12)	Initial temperatures	Rock mass, primary area	TSw2	NS	NS	NS	NS	Initial temperatures	Rock mass	8 3 1 15 2 2 1	(g)	TSw2
1 10 (8 3 4 2)	Initial temperatures	Rock mass, primary area	TSw2	$\pm 3^\circ\text{C}$	Medium	23-25°C	Medium	Initial temperatures	Rock mass	8 3 1 15 2 2 1	(g)	TSw2
1 11 (8 3 2 2)	Initial temperatures	Rock mass, primary area and extensions	TSw2	$\pm 3^\circ\text{C}$	Medium	23-26°C	Medium	Initial temperatures	Rock mass	8 3 1 15 2 2 1	(g)	TSw2 and above
4 4 (8 3 2 5)	Initial temperatures	Rock mass, primary area	TSw2	23 25°C	Medium	23 25°C	Medium	Initial temperatures	Rock mass	8 3 1 15 2 2 1	(g)	TSw2

8.3.1.15-12

CONSULTATION DRAFT

Table 8.3.1.15-1. Performance and design parameters, tentative goals, and characterization parameters for thermal and mechanical properties program^a (page 12 of 12)

Issue requesting parameter (SCP section)	Performance or design parameter	Material type and spatial location ^b	Stratigraphic location ^c	Tentative goal ^{c,d,e}	Needed confidence ^{c,d}	Current estimate ^c	Current confidence ^{c,d}	Parameter to be measured	Material type tested	SCP activity numbers	Spatial location	Stratigraphic location ^b
4 4 (8 3 2 5) (continued)	Initial temperatures	Rock mass, primary area	TSw2	±2°C	Medium	Present values ±2°C	Medium	Initial temperatures	Rock mass	8 3 1 15 2 2 1	(g)	TSw2
	Initial temperatures	Rock mass, primary area	Ground surface to base of TSw2	±2°C	Medium	Present values ±2°C		Initial temperatures	Rock mass	8 3 1 15 2 2 1	(g)	Alluvium, TCw, PTn, TSw1, TSw2

^aThis table summarizes requirements of both preclosure and postclosure issues

^bDefinitions of the primary area and extensions are provided in Chapter 6, Figure 6 87

^cThe thermal/mechanical stratigraphy at Yucca Mountain is shown in Figure 2 5 of Chapter 2 CHn = Calico Hills nonwelded unit, PTn = Paintbrush nonwelded unit, TCw = Tiva Canyon welded unit, TSw = Topopah Spring welded unit, and NS = not specified

^dThe manner in which tentative goals and levels of confidence are used in planning the characterization program is discussed in the investigation for Section 8 3 1 15 1

^e_x - mean value of existing sample group

^fTentative goal is that a prescribed percentage (related to the needed confidence) of the data falls within the given interval failure to meet the goal will result in a need to reevaluate the existing design

^gSpatial locations will be a combination of new boreholes (location to be determined, see Investigation 8 3 1 4 1 for discussion) and the exploratory shaft and associated underground excavations, ESF = exploratory shaft facility

^hStratigraphic locations will be in the units specified as required by pertinent issues if measurements need to be made For many parameters for which the required confidence level is low, existing data will be sufficient to satisfy the requirements

ⁱ σ_v = vertical in situ stress, σ_h = minimum horizontal in situ stress, σ_H = maximum horizontal in situ stress

^j ρgh indicates the product of density (ρ), gravitational acceleration (g), and height of overlying column of rock (h)

8.3.1.15-13

CONSULTATION DRAFT

CONSULTATION DRAFT

The stratigraphic locations in Table 8.3.1.15-1 are thermal/mechanical units rather than formal stratigraphic units. This approach has been taken because the repository design process uses the thermal/mechanical units as the stratigraphic framework for analysis. The relationship between formal stratigraphic units and thermal/mechanical units is provided in Figure 2-5 in the introduction to Chapter 2.

In addition to the parameter requirements listed in Table 8.3.1.15-1, several additional requirements from design issues affect the characterization program described in this section. Data on the multidimensional deformations that may result from repository-induced stresses will be obtained from the Yucca Mountain heated block experiment (Activity 8.3.1.15.1.6.3). In addition, information on opening stability and ground support systems, required by Issue 4.2 (Section 8.3.2.4) will be obtained as part of Activities 8.3.1.15.1.5.2, 8.3.1.15.1.5.3, and 8.3.1.15.1.6.5, and Study 8.3.1.15.1.8.

Figure 8.3.1.15-1 shows the ties between the investigation for acquisition of data on thermal and mechanical rock properties (Investigation 8.3.1.15.1) and performance assessment and design issues. Detailed logic diagrams are presented in Figure 8.3.1.15-2 (bulk, thermal, and mechanical properties) and Figure 8.3.1.15-3 (ambient stress and temperature conditions) as a supplement to the details in Table 8.3.1.15-1. These detailed diagrams show the studies and activities planned to provide the site data required by the performance and design issues.

Approach to satisfy performance and design requirements

The performance allocation process as described in Section 8.2 requires the definition of performance goals for design and performance assessment issues. These performance goals then are used to define the data necessary to determine whether the goals can be met. The required thermal and mechanical data are listed in Table 8.3.1.15-1. The characterization goals in the table are quantitative estimates of the maximum variability in a parameter that can be tolerated without necessitating a change in the existing design. Required confidence levels are a measure of how important it is that the specified limits are met. Both characterization goals and confidence levels have been estimated for performance assessment and design issues based on limited sensitivity studies or on expert judgment. When more than one issue requires a given parameter at the same location, the requirement that poses the greatest constraint will be used in planning site studies and activities to obtain values for the parameter. As site characterization proceeds, some proportion of the site data values may be found to fall outside the specified limits. If this occurs, the portions of the design or of the performance assessment programs affected by these data will be reevaluated to assess the impact. New limits to these data may be specified, and additional data will be collected if necessary.

In addition to the iterative process outlined in the preceding paragraph, the possibility exists that not all necessary data have been identified or that the specified limits are invalid because of the preliminary nature of the supporting sensitivity studies. In these cases, additional data may be requested or the specified limits for a parameter already

8.3.1.15-15

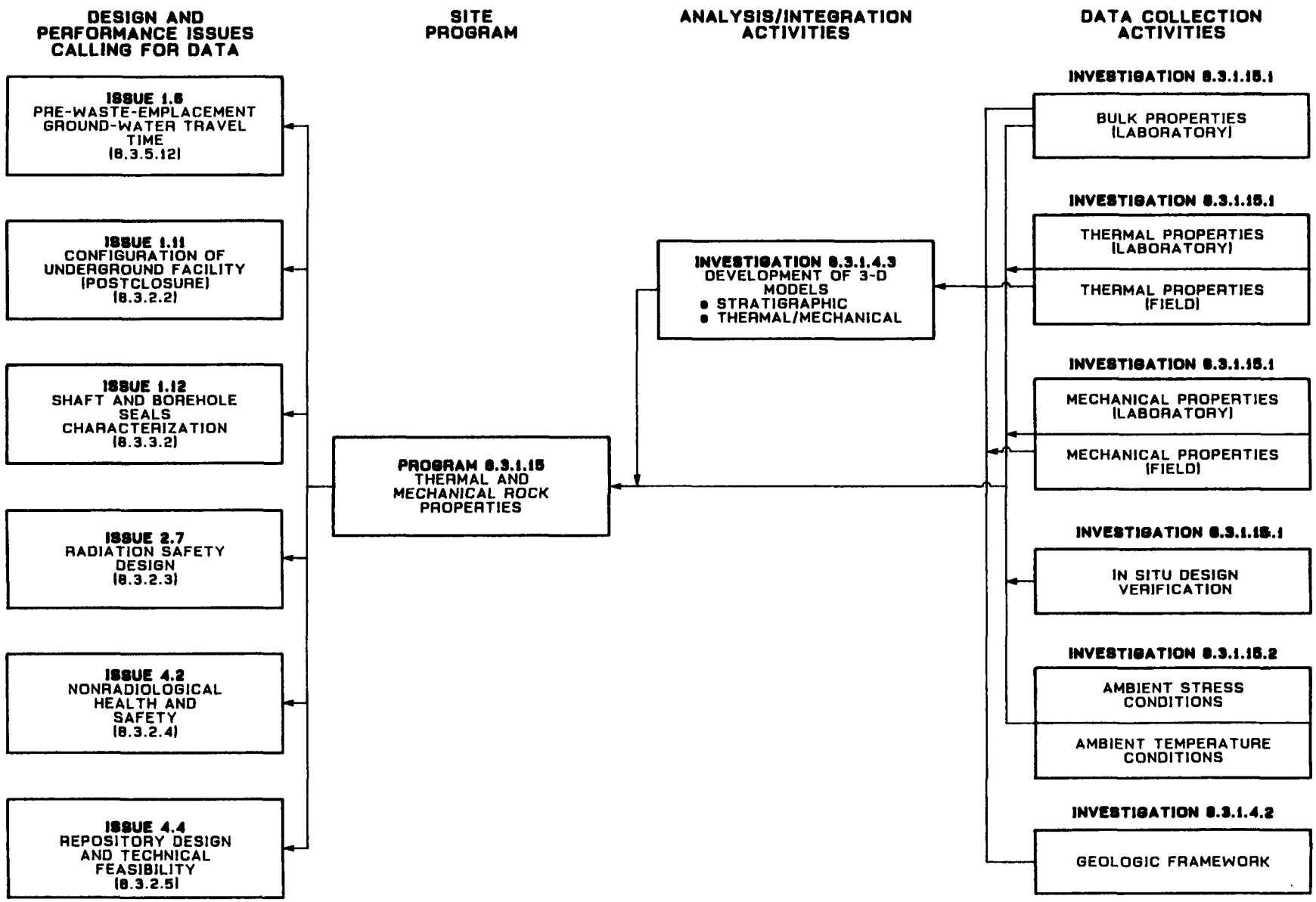

CONSULTATION DRAFT

Figure 8.3.1.15-1. Relationship between data acquisition for rock properties and issues requiring the data.

CONSULTATION DRAFT

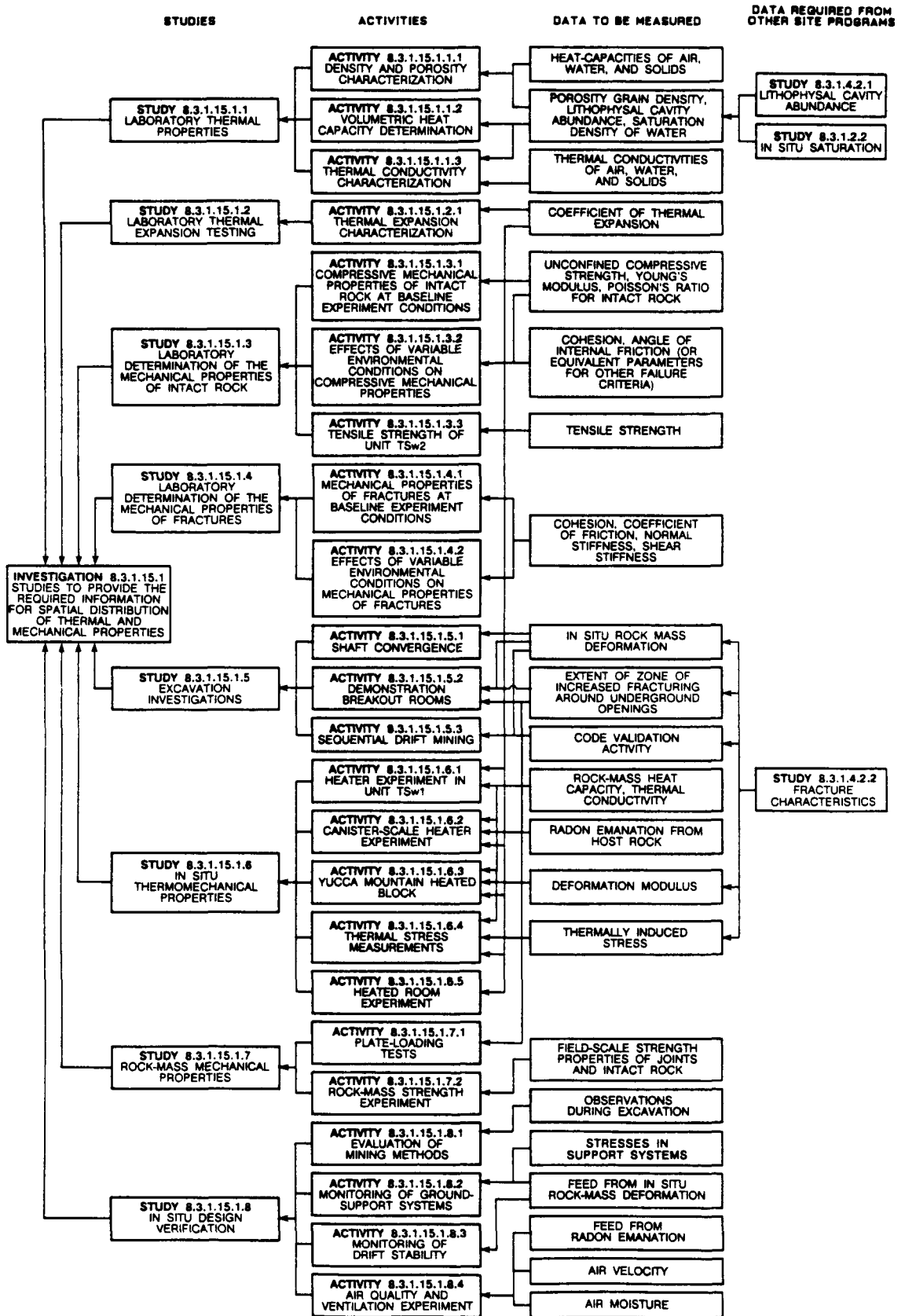

Figure 8.3.1.15-2. Logic diagram for Investigation 8.3.1.15.1, spatial distribution of thermal/mechanical rock properties.

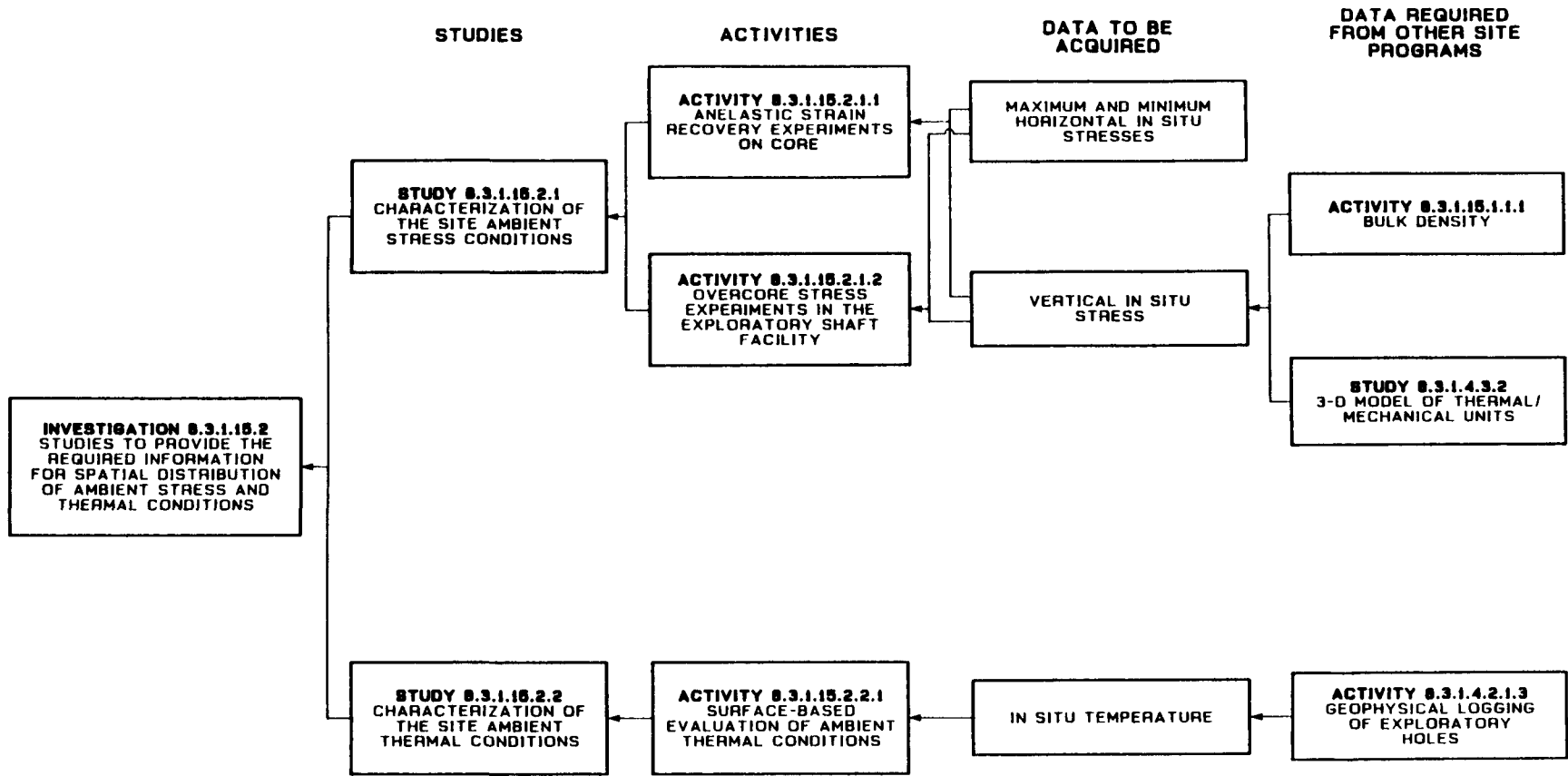

Figure 8.3.1.15-3. Logic diagram for Investigation 8.3.1.15.2, spatial distribution of ambient stress and temperature conditions

CONSULTATION DRAFT

requested may be changed. Either situation might lead to a modification to the investigations outlined in Sections 8.3.1.15.1 and 8.3.1.15.2.

Interrelationships of thermal and mechanical rock properties investigations

As shown on Figures 8.3.1.15-2 and 8.3.1.15-3, two investigations and ten studies are planned to collect the required rock characteristics data. The studies consist of those related to laboratory determination of thermal and mechanical properties, to in situ experiments in the exploratory shaft, and to characterization of ambient stress and thermal conditions. Studies related to laboratory testing are grouped by parameter(s). In contrast, in situ experiments are divided into four categories by type of experiment: (1) experiments related to evaluation of the effects of excavation, (2) mechanical property experiments, (3) thermomechanical property experiments, and (4) in situ design verification experiments. Characterization of ambient stress and thermal conditions will include measurements of stress and temperature in exploratory holes and in the exploratory shaft.

The schedule information provided for investigations in this section includes the sequencing, interrelationships, and relative durations of the studies in the investigation. Specific durations and start/finish dates for the studies are being developed as part of ongoing planning efforts and will be provided in the SCP at the time of issuance and revised as appropriate in subsequent semiannual progress reports.

8.3.1.15.1 Investigation: Studies to provide the required information for spatial distribution of thermal and mechanical properties

Technical basis for obtaining the information

Link to the technical data chapters and applicable support documents

Chapter 2 summarizes the available data relevant to thermal and mechanical properties of the tuff units at Yucca Mountain.

Parameters

Table 8.3.1.15-1 presented in the previous section summarizes the thermal/mechanical properties required for resolution of performance assessment and design issues. Table 8.3.1.15-2 summarizes the thermal and mechanical properties listed in Table 8.3.1.15-1. These properties will be used with the other data on rock characteristics to develop the three-dimensional thermal, mechanical, and thermomechanical models in Section 8.3.1.4.3. Several additional parameters also are required to enable estimates to be made for some of the parameters listed in Table 8.3.1.15-2. These additional parameters include grain density, heat capacity, and thermal conductivity of zero-porosity material, lithophysal cavity abundance, and in situ saturation state. The relevance of each of these parameters is discussed later. All are to be obtained in the studies contained in Investigation 8.3.1.15.1 with the exception of lithophysal cavity abundance and saturation state. Acquisition of data on cavity abundance is discussed in Investigation 8.3.1.4.2 (geologic framework), whereas data acquisition for

CONSULTATION DRAFT

Table 8.3.1.15-2. Thermal and mechanical properties required by other issues

Property	Matrix	Fractures	Rock mass
<u>Thermal</u>			
Thermal conductivity			x
Heat capacity			x
<u>Thermomechanical</u>			
Coefficient of thermal expansion	x		
<u>Mechanical</u>			
Poisson's ratio	x		
Young's modulus	x		
Deformation modulus			x
Compressive strength	x		
Cohesion	x		
Angle of internal friction	x		
Fracture properties			
Cohesion		x	
Coefficient of friction		x	
Normal stiffness		x	
Shear stiffness		x	
Joint wall compressive strength		x	
Roughness coefficient		x	
<u>Miscellaneous</u>			
Bulk density			x
Radon emanation			x
Excavation observations		x	x

saturation state is discussed in Investigations 8.3.1.2.2 and 8.3.1.2.3 (site unsaturated and saturated zone hydrologic system).

Purpose and objectives of the investigation

The purpose of this investigation is to provide the information on spatial distribution of thermal and mechanical properties requested by performance and design issues. The performance allocation process identified performance measures and goals. To determine whether the performance goals can be met, data must be available on various site parameters, and the data must have associated levels of confidence. The parameters and associated confidence levels are identified in the performance assessment and design issues, and serve as the basis for planning of a site characterization

CONSULTATION DRAFT

program. The information required by performance assessment and design issues on bulk, thermal, and mechanical properties is shown in Table 8.3.1.15-1 together with the activities planned to acquire site characterization data on these properties. The general link between the site characterization program and the issues requiring data was shown in Figure 8.3.1.15-1, and Figure 8.3.1.15-2 depicts the detailed logic for completion of this investigation.

Technical rationale for the investigation

Completion of this investigation requires the acquisition of data for each parameter listed in Table 8.3.1.15-2 as well as evaluation of the spatial variation of each parameter. Preliminary data are available for most of these parameters, as summarized in Chapter 2. However, additional data are required to analyze spatial variability of properties and, for some parameters, to obtain the required number of data.

Of the parameters listed in Table 8.3.1.15-2, thermal expansion coefficients, Poisson's ratios, Young's moduli, compressive strength (laboratory), and tensile strength will be obtained directly from laboratory measurements. Joint properties (normal and shear stiffnesses, cohesion, and friction coefficient) will also be measured in the laboratory, but with the realization that it will be necessary to scale the results to achieve relevance to in situ conditions.

Several of the parameters identified in Table 8.3.1.15-2 are intended to be representative of the rock mass; they are included in the table in recognition of the fact that the rock-mass behavior cannot be adequately characterized by laboratory-determined parameter values alone. The approach taken in this section is to consider two categories of parameters in addressing the question of whether the laboratory and field-obtained data are representative of the rock mass.

In the first category, which includes parameters such as in situ bulk density, heat capacity, and thermal conductivity, data applicable to the rock mass will be calculated or estimated from other parameters not specifically required by performance assessment or design issues, such as grain density, mineral constituents, and porosity. Knowledge of laboratory-measured values of these non-required parameters, and their variability in the laboratory or in situ, will support the determination of rock-mass data for required parameters in the first category. Calculated data for the rock mass, together with related laboratory data, can be compared with the corresponding parameter values obtained from field experiments. Historical evidence suggests that there is likely to be good correlation between laboratory and field results for this category of in situ parameters. Any discrepancies that may arise between predicted in situ parameter values and the measured in situ values will be assessed to ascertain the adequacy of the predictive algorithm and of the measurement techniques used in field tests. If necessary, the basis of any predictive algorithm used will be reevaluated and additional laboratory or field tests may be performed. These additional tests could be required because of a need to measure different parameters, a need to repeat measurements under different test conditions, or a need to revise in situ measurement techniques.

CONSULTATION DRAFT

The second category of parameters that can be obtained from in situ tests, including such parameters as rock-mass deformability and rock-mass strength, will be treated differently. The parameters in this category are not expected to be calculable using simple predictive equations and laboratory-obtained parameter values. Rather, parameters in this category are sensitive to the scale of the test (volume of rock material involved in the test). It is expected that field measurements of parameters other than the parameter of interest will be required to estimate the in situ value of the parameter. For the rock-mass deformation properties identified in this section, fracture geometry, characteristics, and properties are the most likely additional required information. Differences between laboratory and in situ measured values for parameters such as deformation modulus are expected to be caused by the presence of fractures in the rock mass on a scale that cannot be included in laboratory samples. Values for deformation properties can be calculated by combining intact-rock properties and fracture characteristics and properties in finite-element computations. Alternatively, the rock-mass properties can be estimated by applying corrections deduced from in situ fracture characteristics to intact-rock properties. Historically, such corrections in the form of reduction factors have been deduced from fracture frequency, or such indices as rock quality designation.

It would be imprudent to plan numerous large-scale tests to measure rock-mass deformation properties considering the time and expense required for such tests. Furthermore, the data from these tests is potentially difficult to interpret. In the planned program, information about rock-mass deformation properties will be obtained through a combination of empirical approaches to rock-mass opening design, sequential instrument emplacement and excavation, and analytical modeling of excavation behavior. The analytical modeling described in Sections 6.4.8 and 8.3.2.8 will make use of both equivalent modulus and compliant joint approaches. The equivalent modulus approach will use the reduced modulus values derived from laboratory modulus tests, observed fracture characteristics, and measured in situ deformation moduli. The compliant joint approach will use laboratory-measured moduli and joint deformation properties such as stiffness, as well as joint characteristics such as location, orientation, and spacing. The results of both modeling approaches will be used to confirm the reduction factor used to estimate in situ deformation moduli.

There are two additional considerations relevant to rock-mass deformation and strength properties. First, the approach to defining the physical interpretation of rock-mass strength still is evolving. Rock-mass strength can be considered in terms of allowable movement on joints, of the strength of the intact rock, or of a combination of the two. Modeling performed to date does not provide confidence in predicting the rock-mass response because of the preliminary nature of the physical models studied and of the data used. Some of the different situations modeled should be examined further using refined codes and a more complete and representative data set. Continuing analyses could indicate the need for site-specific in situ rock strength data to be obtained during site characterization. Such data probably would consist of large-deformation response testing of fractures in situ, perhaps incorporating the effects of heat. Plans for such studies are maturing; results from ongoing analyses and advanced conceptual design activities will need to be incorporated in the development of such plans.

CONSULTATION DRAFT

The second additional consideration relevant to rock-mass deformability involves the estimation of in situ modulus of deformation. Estimation of in situ modulus of deformation will involve a combined examination of spatial variability in Young's modulus as determined through statistical analysis of laboratory data, of limited field measurements, demonstration excavations, modeling, and spatial variability of other in situ properties such as fracture characteristics. This approach could be sensitive to significant changes in rock-mass conditions such as fracture characteristics. The planned program should be sufficiently flexible to provide a methodology for confirming estimated values of rock-mass modulus should significant changes in fracture characteristics be encountered within the exploratory shaft facility (ESF) or within the boundaries of the repository excavation. It will not be known in advance of ESF excavation whether lateral variability in fracture characteristics would be significant to the point of requiring additional confirmatory testing of deformation modulus within the ESF beyond the testing already planned.

Parameters that vary as a function of saturation (i.e., bulk density, heat capacity, thermal conductivity, and the strength of intact rock) are difficult to characterize for all possible saturation states. Estimates of these parameters will be obtained from known parameters by following the steps described below (bulk density will be used as an example):

1. Calculate the mean value of the parameter to be estimated using the mean values of the known parameters:

$$\rho_b = \rho_g(1 - \phi) + \rho_w \phi S \quad (8.3.1.15-1)$$

where

- ρ_b = bulk density
- ρ_g = grain density
- ϕ = porosity (matrix porosity and lithophysal cavities)
- ρ_w = density of water
- S = saturation.

2. Obtain the partial derivatives of Equation 8.3.1.15-1 (or the equivalent equation for another parameter) with respect to the known parameters (e.g., $\frac{\partial \rho_b}{\partial \rho_g}$, $\frac{\partial \rho_b}{\partial \phi}$, $\frac{\partial \rho_b}{\partial S}$, $\frac{\partial \rho_b}{\partial \rho_w}$)
3. Calculate the standard deviation of the parameter to be estimated (e.g., ρ_{db}) using the partial derivatives from step 2 and the standard deviations of the known parameters:

$$\sigma_{\rho_b} \approx \left[\sigma_{\rho_g}^2 \left(\frac{\partial \rho_b}{\partial \rho_g} \right)^2 + \sigma_{\phi}^2 \left(\frac{\partial \rho_b}{\partial \phi} \right)^2 + \sigma_S^2 \left(\frac{\partial \rho_b}{\partial S} \right)^2 + \sigma_{\rho_w}^2 \left(\frac{\partial \rho_b}{\partial \rho_w} \right)^2 \right]^{1/2} \quad (8.3.1.15-2)$$

where the partial derivatives are evaluated at the mean values of the known parameters. Note that the implicit assumption is made in the use of Equation

CONSULTATION DRAFT

8.3.1.15-2 that all variables on the right-hand side for which standard deviations are given are independent random variables.

Use of statistics in design of characterization program. For most of the parameters listed in Table 8.3.1.15-2, preliminary data are available that can be used to estimate future testing requirements for satisfaction of the information need. These preliminary data are the result either of measurements in the laboratory or of the estimating procedure outlined above. The parameters for which such preliminary data are not available are fracture properties (cohesion, coefficient of friction, normal stiffness, and shear stiffness). The logic for determining the fracture properties with the required confidence is presented at the end of the following discussion.

Preliminary data, whether obtained from measurements or estimated from known parameters, provide values for the mean (\bar{x}) and standard deviation (s) for each parameter. These two quantities are estimates based on samples from a population with a true mean value (μ) and standard deviation (σ). It is these latter two parameters that are needed when determining whether tolerance limits specified by performance and design issues are being met. The uncertainty caused by knowing \bar{x} and s rather than μ and σ is accounted for during estimation of the number of samples to be tested in order to meet the specified tolerance limits. A method (Bowker and Lieberman, 1972) for this estimation is summarized in the following paragraph.

To obtain initial estimates of testing requirements, all parameters discussed in this section have been assumed to be normally distributed. The validity of this assumption will be checked for each parameter during site characterization activities. Under this assumption, existing data are used to calculate \bar{x} and s . The requirements imposed by performance and design issues are that some proportion γ of the interval $\bar{x} \pm ks$ will include 100(1 - α) percent or more of the true distribution, where α is the level of significance (Bowker and Lieberman, 1972) and k is related to α , γ , and n , the number of samples. In this analysis, γ is a preassigned probability that the interval between $\bar{x} - ks$ and $\bar{x} + ks$ includes at least a specified proportion (1 - α) of the true distribution.

For the parameters under discussion here, some of the performance and design issues specify the magnitude of ks within which the proportion (1 - α) is to be found (issues that do not provide such a specification have parameter goals that are less stringent for a test program).

<u>Specified confidence</u>	<u>α</u>
High	0.05
Medium	0.10
Low	0.25

Note that for convenience, (1 - α) is assumed to be the same as γ . Given values of α , γ , k , and an assumed statistical distribution, statistical tables can be used to estimate n , the number of samples to be tested in order to satisfy the specified requirements. Depending on the structure of observed data, it may be appropriate to use types of distribution functions

CONSULTATION DRAFT

other than the normal distribution for revising the estimates of the required number of samples.

For example, to calculate the vertical in situ stress in unit TSw2 with medium confidence, the in situ bulk density of unit TSw2 must be known with medium confidence. Thus, from the preceding discussion, $\gamma = (1 - \alpha) = 0.90$. If the range were required to be $\bar{x} \pm 0.1\bar{x}$, then equating k_s and $0.1\bar{x}$ would give $k = 0.1\bar{x}/s \approx 2.13$. Entering the appropriate table in Bowker and Lieberman (1972), the number of samples is found to be 22.

Two comments on this technique are necessary. First, the values of n obtained are estimates based on the preliminary data currently available. These values of n may need to be revised as site characterization data become available because the possibility exists that the preliminary data and the site characterization data will provide different estimates of μ and σ .

Secondly, the values of n are for a specified set of conditions at which preliminary data were obtained. No a priori assumptions have been made either about spatial variability of a parameter or about the variability in a parameter resulting from changes in the experiment environment. If a parameter should vary as a function of spatial location or experiment conditions, then n measurements should be obtained at each set of relevant experiment conditions or for each selected spatial location. This point will be discussed again for individual studies and activities later in this section.

For the fracture properties, values of \bar{x} and s are not available, so that n cannot be estimated by the procedure discussed above. Instead, the number of samples to be tested initially will be selected arbitrarily. The data from these initial experiments then will be used to estimate n , and additional experiments will be conducted if necessary.

Some parameters have preliminary data for which natural variability is quite large. The large variability could result from a number of causes, but present data are insufficient to distinguish specific reasons (i.e., a large variability could be real or a large variability could result from combining samples from two or more distinct populations). Regardless of the cause, for these parameters the existing value of s is too large to allow calculation of n using the tolerance limits requested by other issues. In these cases, the initial value of n arbitrarily will be assumed to be as follows:

<u>Specified confidence</u>	<u>Number of samples</u>
High	40
Medium	20
Low	10

Data obtained from these experiments then will be used to reassess whether the requested tolerance limits can be met using the normal distribution function or other distribution functions, as applicable. If not, either new tolerance limits will be set, and the impact on repository design or performance will be evaluated, or additional experiments will be performed to

CONSULTATION DRAFT

determine whether an increased sample size will reduce the observed variability. Evaluation of data sufficiency after initial sampling and testing will be used with other information to help decide if additional testing is necessary.

The preceding discussion is based in part on the assumption that the sample used to obtain \bar{x} and s is a random sample of the total population. Each thermal/mechanical unit is a three-dimensional body; the five existing core holes comprise only a partially random sample of the units, as will the exploratory shaft (ES) excavations. In fact, a site characterization program in which core holes and underground excavations are designed to investigate specific areas or features of interest can be considered to provide approximations rather than statistically representative calculations.

In view of the limitations on the randomness of sampling, the next best situation is one in which coverage of the repository area is maximized. The existing core holes within and close to the area are situated near the northern and southern limits. The ES facilities will expand coverage of the northern area within the repository unit (thermal/mechanical unit TSw2) and perhaps within thermal/mechanical units CHn1v and CHn1z. However, the central and southern portions of the repository area will not be sampled as part of the ES facility; even sampling of the northern portion will be relatively sparse for thermal/mechanical units other than those mentioned previously. This situation suggests that coring of several new core holes is necessary for the determination of the spatial variability of thermal and mechanical properties.

Preliminary data suggest that spatial variability of these properties is small within TSw1 and TSw2 (Nimick and Schwartz, 1987). However, additional data are required for these and other units in the central and southern portions of the repository area. Also, data for units lying below the top of CHn1z must be obtained from at least one additional core hole in the northern part of the area, because the ES will not be sufficiently deep to provide samples of these units. As stated earlier, the estimated values of n for individual parameters in individual thermal/mechanical units will apply for each core hole and for the ES.

In addition to measurement of parameters on samples from different core holes to assess spatial variability, a portion of the experiments (≤ 10 percent) will be replicated at more than one testing laboratory. Replications will consist of round-robin, nondestructive experiments or of experiments on side-by-side samples for destructive testing. The replication will serve to verify that the primary testing laboratory is producing accurate results. Assuming that the different laboratories produce similar results, the additional data will be used to supplement the data base of laboratory-determined properties. If the additional data are redundant (i.e., if data from a nondestructive experiment on a sample are already in the data base), supplementation of the data base will consist of notation that the data have been verified through duplicate testing. If testing results are different, an assessment of the probable cause(s) of the differences will be performed and necessary changes or additions to the testing program will be made.

As discussed previously, acquisition of thermal and mechanical properties with the confidences requested by performance and design issues requires

CONSULTATION DRAFT

minimum numbers of experiments that vary with each property. The relatively large number of laboratory tests will augment the data available from a necessarily limited number of in situ tests. Values of rock-mass properties that will be obtained from in situ thermal and mechanical tests will serve as guideline properties and will be used to examine the validity of estimating rock-mass properties using laboratory data combined with information about in situ fracture characteristics.

In addition to providing estimates of rock-mass properties, in situ experiments will serve other purposes. Some tests will be used to monitor the behavior of underground excavations in units TSw1 and TSw2. Both qualitative and quantitative information will be obtained from these observations. Quantitative information for one experiment (sequential drift mining, Activity 8.3.1.15.1.5.3) will be used for code validation work on codes used to calculate mechanical response to imposed stresses. Validation work also will be performed for codes that calculate thermal, mechanical, or coupled thermal and mechanical responses to imposed temperatures and stresses using data from the canister-scale heater and heated-block experiments. In general, the codes to be validated will be used to contribute to the resolution of Issues 1.11 and 4.4 (Sections 8.3.2.2 and 8.3.2.5). Additional discussion of code-validation work is presented in Section 8.3.2.1.4.

8.3.1.15.1.1 Study: Laboratory thermal properties

The objective of this study is to provide laboratory characterization of thermal conductivity and heat capacity and the spatial variability thereof. In order to do so, porosity, grain density, and the heat capacity and thermal conductivity of zero-porosity material also must be characterized. The discussion for Activities 8.3.1.15.1.1.1, 8.3.1.15.1.1.2, and 8.3.1.15.1.1.3 applies for each new core hole and for the exploratory shaft (ES). Testing frequency at the main test level in the ES will depend on spatial variability.

The validity of extrapolation of laboratory-determined thermal properties to in situ conditions will be examined by comparison of the properties with data obtained from in situ heater tests in the ES. Temperature fields induced during the heater tests will be modeled using numerical techniques, with values for thermal properties being varied until an optimum match of predicted and actual temperatures is obtained. Additional discussion of the heater tests is presented for Activities 8.3.1.15.1.6.1, 8.3.1.15.1.6.2, 8.3.1.15.1.6.3, and 8.3.1.15.1.6.5 under Study 8.3.1.15.1.6.

8.3.1.15.1.1.1 Activity: Density and porosity characterization

Objectives

The objective of this activity is to obtain data on density and porosity and to evaluate the spatial variability thereof. Data will contribute to determination of in situ thermal properties (porosity and grain density), to

CONSULTATION DRAFT

vertical in situ stress (bulk density), and radiation-shielding properties (bulk density).

Parameters

The parameters for this activity are matrix porosity, grain density, and in situ bulk density. (Matrix porosity refers to the total void space, as distinguished from the effective porosity that is available for hydrologic flow.) Parameters required that are to be supplied by other investigations are in situ saturation and lithophysal cavity abundance.

Description

The number of experiments necessary to characterize the density and porosity of each thermal/mechanical unit in Activity 8.3.1.15.1.1 are given in Table 8.3.1.15-3. These numbers have been obtained using available data as discussed under the technical rationale for this investigation. The numbers are based on the number of experiments estimated as necessary for bulk density, volumetric heat capacity, and thermal conductivity (as needed for this activity and for Activities 8.3.1.15.1.1.2 and 8.3.1.15.1.1.3). The number of experiments applies to each new core hole and to the exploratory shaft. Each experiment will require approximately 65 cm³ of material.

In addition to the experiments listed in Table 8.3.1.15-3, grain density and porosity data will be gathered from other samples. Values will be obtained for 5 to 10 samples of material taken from instrumentation holes in the vicinity of in situ experiments in the exploratory shaft facility. These site-specific values will aid in the interpretation of in situ experiment results and will add to the data base for units TSw1 and TSw2.

Also, density and porosity data will be obtained on samples tested for thermal and mechanical properties by measurement of dry and saturated bulk densities of the samples. These data will be somewhat less precise than those gathered by the more standardized techniques listed below but will be specific to the individual test samples. This specificity will enhance the ability to interpret mechanical and thermal test results.

Grain densities (ρ_g) and dry bulk densities (ρ_{db}) will be measured. Matrix porosities then will be calculated by

$$\phi = 1 - \frac{\rho_{db}}{\rho_g} \quad (8.3.1.15-3)$$

Data for grain density and matrix porosity will be combined with data on lithophysal cavity abundance and in situ saturation state to calculate in situ bulk densities. These bulk densities then will be used to calculate the vertical component of in situ stress.

Methods and technical procedures

The methods and technical procedures for Activity 8.3.1.15.1.1 are given in the following table.

Table 8.3.1.15-3. Experiments required for rock properties characterization

Unit ^a	Rock property and activity					Compressive mechanical properties (8.3.1.15.1.3) and (8.3.1.15.1.3.2)
	Bulk density ^b (8.3.1.15.1.1.1)	Density and porosity ^c (8.3.1.15.1.1.1)	Heat capacity (8.3.1.15.1.1.2)	Thermal conductivity (8.3.1.15.1.1.3)	Thermal expansion (8.3.1.15.1.2.1)	
TCw	20	20	-- ^d	--	--	10
PTn	20	20	10	10	10	10 ^f
TSw1	20	20	20	20	30 ^e	20 ^f
TSw2	22	40	40	40	40 ^g	40
TSw3	3	20	20	20	20	20
CHn1v	10	20	20	20	20	20
CHn1	12	20	20	20	20	20
CHn2z	10	10	10	10	10	10

^aThe relationship between thermal/mechanical units and formal stratigraphic units is provided in the introduction to Chapter 2.

^bNumbers of experiments for bulk density are calculated based on requirements for vertical in situ stress or on requirements for TSw2 related to radon emanation rate.

^cNumber of experiments for density and porosity are related to the experiments required for bulk density, characterization of heat capacity, and thermal conductivity indicated in this table.

^dConsidered to be represented by data for TSw1 and TSw2, because of similarities in lithology.

^e20 experiments in lithophysae-rich material, 10 experiments in lithophysae-poor material (see Activity 8.3.1.15.1.2.1 for discussion).

^f(lithophysae-poor TSw1).

^g20 experiments each confined and unconfined.

CONSULTATION DRAFT

Method	Technical procedure ^a		Date
	Number	Title	
Measurement of dry bulk density	TP-57	Procedure for determining bulk density	TBD ^b
Measurement of grain density	TP-58	Procedure for determining grain density	TBD

^aNationally recognized procedures will be modified to conform to requirements of the NNWSI Project Quality Assurance program when producing the procedures listed in the table.

^bTBD = to be determined.

8.3.1.15.1.1.2 Activity: Volumetric heat capacity characterization

Objectives

The objectives of this activity are to obtain data for volumetric heat capacity and to evaluate the spatial variability thereof. The data will be used in calculations of the thermal response to the presence of heat-producing waste in unit TSw2.

Parameters

The parameters for this activity are the estimated in situ values of volumetric heat capacity. Parameters required from other investigations include in situ saturation and lithophysal cavity abundance. Parameters required from other activities within this investigation are matrix porosity and grain density.

Description

To estimate in situ values of volumetric heat capacity, data are required for grain density, matrix porosity, lithophysal cavity abundance, in situ saturation, and the heat capacities (C_p) of air, water, and solids. All of these, with the exception of the heat capacity of solids, will be available either in handbooks or as the result of other site characterization activities.

The number of experiments to be performed in each new core hole to determine the heat capacity of solids for each thermal/mechanical unit in Activity 8.3.1.15.1.1.2 are given in Table 8.3.1.15-3. These numbers are the number of experiments estimated as necessary for volumetric heat capacity. Each experiment will require approximately 65 cm³ of material. Each experiment on material from units TSw1, TSw2, TSw3, CHn1v, and CHn1z will include

CONSULTATION DRAFT

measurements over the temperature range from 25 to 275°C. For other units, the temperature range will be from 25 to 100°C. For some units, data from other units are assumed to be representative based on lithologic similarity. Because the units that are not to be tested directly will be outside the temperature field produced by the repository, the impact of this assumption is expected to be negligible.

In addition to the experiments listed in Table 8.3.1.15-3, heat capacity data will be gathered from other samples. Values will be obtained for two to three samples of material taken from instrumentation holes in the vicinity of in situ experiments in the exploratory shaft facility. These site-specific values will aid in the interpretation of in situ experiment results and will add to the data base for units TSw1 and TSw2.

The data obtained from the measurements will be used to calculate volumetric heat capacity (ρC_p) using the following equation (Nimick and Schwartz, 1987):

$$(\rho C_p)_{\text{in situ}} = \rho_g(1 - \phi_m - \phi_L)C_p^s + \phi_m S \rho_{H_2O} C_p^{H_2O} + [\phi_m(1 - S) + \phi_L] C_p^{\text{air}} \rho_{\text{air}} \quad (8.3.1.15-4)$$

where

ρ_g = grain density,

C_p^s = heat capacity of solid material,

S = saturation,

ϕ_m = matrix porosity,

ϕ_L = volume fraction of lithophysal cavities,

ρ_{H_2O} = density of water,

ρ_{air} = density of air,

C_p^{air} = heat capacity of air,

$C_p^{H_2O}$ = heat capacity of water.

Because the density of air is so low, the last term is usually dropped from Equation 8.3.1.15-4. C_p^s and $C_p^{H_2O}$ and ρ_{H_2O} are functions of temperature, so that ρC_p also is a function of temperature. The temperature ranges for which ρC_p will be obtained are the same as those specified earlier for C_p^s .

CONSULTATION DRAFT

Methods and technical procedures

The methods and technical procedures for Activity 8.3.1.15.1.1.2 are given in the following table.

Method	Technical procedure ^a		Date
	Number	Title	
Heat capacity determination	TP-49	Procedure for determination of heat capacity	TBD ^b
Thermogravimetric analysis	TP-50	Procedure for thermogravimetric analysis	TBD

^aNationally recognized procedures will be modified to conform to requirements of the NNWSI Project Quality Assurance program when producing the procedures listed in the table.

^bTBD = to be determined.

8.3.1.15.1.1.3 Activity: Thermal conductivity characterization

Objectives

The objectives of this activity are to obtain data for thermal conductivity and to evaluate the spatial variability thereof. The data will be used in calculations of the thermal response to the presence of heat-producing waste in unit TSw2.

Parameters

The parameters for this activity are estimates of in situ thermal conductivity. Parameters required from other investigations are in situ saturation and lithophysal cavity abundance. A parameter required from another activity in this investigation is matrix porosity. These parameters will be combined in an appropriate model with the thermal conductivities of air, water, and solids to estimate in situ thermal conductivity.

Description

To estimate in situ values of thermal conductivity, data are required for the thermal conductivity of the solid material, air, and water and for matrix porosity, lithophysal cavity abundance, and in situ saturation. All of these, with the exception of the thermal conductivity of solids, will be available either in handbooks or as the result of other site characterization activities.

The number of experiments to be performed to determine the thermal conductivity of solids for each thermal/mechanical unit included in this

CONSULTATION DRAFT

activity are given in Table 8.3.1.15-3. These numbers are those estimated as necessary for thermal conductivity of the bulk material, using available data and the procedures outlined earlier in the technical rationale discussion for this investigation. For some units, data from other units are assumed to be representative based on lithologic similarity. The impact of this assumption is expected to be negligible because the untested units will be outside the temperature field produced by a repository. Each experiment on material from units TSw1, TSw2, TSw3, CHnlv, and CHnlz will include measurements over the temperature range from 25 to 275°C. For other units, the temperature interval will be 25 to 100°C. Each experiment will use a sample that is equal to or smaller than 13 cm of NX (approximately 50 mm diameter) core; actual size will depend on the final experimental technique.

In addition to the experiments listed in Table 8.3.1.15-3, thermal-conductivity data will be gathered from other samples. Values will be obtained for two to three samples of material taken from instrumentation holes in the vicinity of in situ experiments in the exploratory shaft facility. These site-specific values will aid in the interpretation of in situ experiment results and will add to the data base for units TSw1 and TSw2.

Thermal conductivity of several samples of Yucca Mountain tuffs will be measured in support of the activity related to determination of in situ temperatures (Activity 8.3.1.15.2.2.1). Data from these measurements also will contribute to the total data base on thermal properties.

The equation that has been used to date in analysis of the NNWSI Project thermal-conductivity data has been a geometric means equation (Nimick and Lappin, 1985):

$$K = K_o^{(1-\phi_T)} K_w^S \phi_m K_a^{[(1-S)\phi_m + \phi_L]} \quad (8.3.1.15-5)$$

where

- K = bulk thermal conductivity,
- K_o = thermal conductivity of solids,
- K_w = thermal conductivity of water,
- K_a = thermal conductivity of air,
- S = saturation,
- ϕ_L = volume fraction of lithophysal cavities,
- ϕ_m = matrix porosity,
- ϕ_T = total porosity ($\phi_m + \phi_L$).

This formulation will be reevaluated against other possible representations; the actual equation that will be used to analyze data for site characterization has not been selected. K_o , K_w , and K_a are functions of temperature, so that K is also a function of temperature. The temperature ranges for which K will be obtained are the same as those specified earlier for K_o .

CONSULTATION DRAFT

Methods and technical procedures

The methods and technical procedures for Activity 8.3.1.15.1.1.3 are given in the following table.

Method	Technical procedure ^a		Date
	Number	Title	
Thermal conductivity determination	TP-46	Procedure for determination of thermal conductivity	TBD ^b

^aNationally recognized procedures will be modified to conform to requirements of the NNWSI Project Quality Assurance program when producing the procedure shown in the table.

^bTBD = to be determined.

8.3.1.15.1.2 Study: Laboratory thermal expansion testing

The objective of this study is to provide laboratory characterization of thermal-expansion behavior and the spatial variability thereof. The discussion that follows applies for each new core hole and for the exploratory shaft (ES). Testing frequency at the main test level in the ES will depend on spatial variability.

8.3.1.15.1.2.1 Activity: Thermal expansion characterization

Objectives

The objective of this activity is to obtain data for thermal-expansion behavior and to evaluate the spatial variability thereof. The data will be used in calculations of thermal stress and deformation associated with the temperature field produced by the presence of heat-producing waste in unit TSw2.

Parameters

The parameter for this activity is the coefficient of thermal expansion.

Description

The number of experiments necessary to obtain the coefficient of thermal expansion for each thermal/mechanical unit in Activity 8.3.1.15.1.2.1 is given in Table 8.3.1.15-3. The numbers have been obtained using available data and the procedure outlined in the technical rationale discussion for

CONSULTATION DRAFT

this investigation. For some units, data from other units are assumed to be representative on the basis of lithologic similarity. The impact of this assumption is expected to be negligible because the untested units will be outside the temperature field produced by a repository. Each experiment for units TSw1, TSw2, TSw3, CHnlv, and CHnlz will include measurements over the temperature range from 25 to 275°C. For other units, the temperature range will be 25 to 100°C. Sample size will be similar to that used in previous experiments (Chapter 2), ranging from 25.4 by 25.4 by 3 mm up to cylinders 50.8 mm in diameter and 101.6 mm in length.

The nature and conditions of the experiments will depend on the thermal/mechanical unit. For thermal/mechanical units other than TSw1 and TSw2, experiments will be performed in the laboratory, and most will be conducted with appropriate confining pressure and pore pressure. This pressure is necessary to obtain an accurate representation of in situ thermal expansion because existing data indicate that thermal-expansion coefficients are a function of confining pressure at temperatures up to approximately 100°C. The discussion of thermal expansion in Chapter 2 indicates that laboratory data obtained in such experiments should be representative of in situ values; this conclusion will be reevaluated as site specific in situ thermal expansion data become available. (Activities 8.3.1.15.1.6.1 through 8.3.1.15.1.6.5).

For thermal/mechanical unit TSw1, data are necessary for both lithophysae-rich and lithophysae-poor portions of the unit. Both portions of unit TSw1 will be characterized by the same method used for the units discussed in the previous paragraph, although samples from the lithophysae-rich portions will be significantly larger than the sizes mentioned earlier.

For unit TSw2, the magnitude of the difference in thermal-expansion behavior for confined versus unconfined conditions will be determined by performing experiments in both ways. The data from this comparison will be useful in distinguishing near-field and far-field thermomechanical properties, if this distinction is necessary. In addition, scoping experiments will be performed to assess the significance, if any, of anisotropy or sample size on the thermal expansion behavior of unit TSw2.

In addition to the thermal-expansion experiments performed to examine spatial variability of this property, experiments will be done on samples collected from the vicinity of in situ experiments that involve elevated temperatures. These thermal-expansion data will be used in the interpretation of in situ experiment results as well as to augment the data base on the thermal expansion of units TSw1 and TSw2.

Methods and technical procedures

The methods and technical procedures for Activity 8.3.1.15.1.2.1 are given in the following table.

CONSULTATION DRAFT

Method	Technical procedure ^a		Date
	Number	Title	
Measurement of thermal expansion	TP-43	Procedure for determination of unconfined thermal expansion	TBD ^b
	TP-44	Procedure for determination of confined thermal expansion	TBD

^aTo the extent possible, nationally recognized procedures will be modified to conform to requirements of the NNWSI Project Quality Assurance program when producing the procedures listed in the table.

^bTBD = to be determined.

8.3.1.15.1.3 Study: Laboratory determination of mechanical properties of intact rock

The objective of this study is to provide laboratory characterization of the mechanical properties of intact rock and the spatial variability thereof. The discussion for Activity 8.3.1.15.1.3.1 applies for each new core hole and for the ES. Testing frequency at the main test level in the ES will depend on spatial variability.

8.3.1.15.1.3.1 Activity: Compressive mechanical properties of intact rock at baseline experiment conditions

Objectives

The objective of this activity is to obtain data for the compressive mechanical properties of intact rock, and the spatial variability thereof, for baseline experiment conditions. These data will be used in mechanical and thermomechanical calculations of stresses and deformations induced by the presence of underground openings in unit TSw2 and overlying units and by the presence of heat-producing waste in unit TSw2.

Parameters

The parameters for this activity include uniaxial compressive strength, Young's modulus, and Poisson's ratio.

Description

As discussed in Chapter 2, the compressive strength of Yucca Mountain tuffs is a function of various conditions, including strain rate, confining pressure, temperature, sample size, and saturation state. To evaluate the effects of these parameters, a set of baseline experiment conditions must be

CONSULTATION DRAFT

defined for which compressive mechanical data will be obtained. These conditions will be as follows:

- Sample diameter: 50.8 mm
- Sample length to diameter ratio: 2.0
- Saturation state: Saturated
- Temperature: 25°C
- Confining pressure: None
- Strain rate: 10^{-5} s^{-1}

The number of experiments to be performed at these conditions for each thermal/mechanical unit in Activity 8.3.1.15.1.3.1 are summarized in Table 8.3.1.15-3. The numbers have been obtained from available data using the procedure outlined in the technical rationale discussion for this investigation. For some units, data from other units are assumed to be representative based on lithologic similarity. Because these units are outside the regions of significantly altered stress and temperature, the impact of this assumption is assumed to be negligible.

In addition to the experiments listed for this activity (8.3.1.15.1.3.1) in Table 8.3.1.15-3, compressive experiments at the baseline conditions will be performed on samples obtained in the vicinity of in situ experiments. The data from these laboratory experiments will aid in the interpretation of in situ experiment results as well as contributing to the data base for the compressive mechanical properties of unit TSw2.

One guideline frequently used in compressive testing is that the diameter of grains and inhomogeneities in the samples be less than 0.1 of the sample diameter. For lithophysae-rich material, this stipulation will necessitate testing samples that are much larger than the baseline size. Samples of two diameters (267 and 381 mm) will be obtained from the walls of the upper demonstration breakout room in the ES and will be tested with all other baseline experimental conditions as listed earlier.

Methods and technical procedures

The methods and technical procedures for Activity 8.3.1.15.1.3.1 are given in the following table.

Method	Technical procedure ^a		Date
	Number	Title	
Compression testing	TP-51	Procedure for determination of compressive mechanical properties	TBD ^b

^aTo the extent possible, nationally recognized procedures will be modified to conform to requirements of the NNWSI Project Quality Assurance program when producing the procedure shown in the table.

^bTBD = to be determined.

CONSULTATION DRAFT

8.3.1.15.1.3.2 Activity: Effects of variable environmental conditions on compressive mechanical properties

Objectives

The objective of this activity is to evaluate the effects of varying sample size, strain rate, saturation state, anisotropy, confining pressure, and temperature on compressive mechanical properties. Data will be used in mechanical and thermomechanical calculations of stresses and deformations induced by the presence of underground openings in unit TSw2 and overlying units and by the presence of heat-producing waste in unit TSw2.

Parameters

The parameters for this activity are unconfined compressive strength, Young's modulus, Poisson's ratio, cohesion, and angle of internal friction.

Description

As discussed in Chapter 2, compressive mechanical properties are a function of the experimental conditions at which the properties are measured. This activity will determine the effects of sample size, strain rate, temperature, confining pressure, saturation state, and anisotropy on the compressive mechanical properties of unit TSw2, the proposed repository horizon. In addition, the effects of confining pressure on the mechanical properties of units TCw, PTn, and lithophysae-poor portions of unit TSw1 will be determined. The number of experiments listed for these units in Table 8.3.1.15-3 for this activity (8.3.1.15.1.3.2) will be performed at each unique set of experimental conditions. Material for testing of unit TSw2 will be obtained from the walls of the excavations at the main test level in the exploratory shaft (ES) facility, whereas samples of other units will be collected from the ES itself.

In addition to the testing just summarized, scoping experiments are ongoing to determine whether creep deformation or deformation at very low strain rates (10^{-8} s^{-1} to 10^{-9} s^{-1}) are of concern for unit TSw2. Samples taken from outcrop at Busted Butte are being tested in compression at low strain rates, elevated temperatures, and in long-term creep experiments. Results will be used to assess whether the experiment program mentioned in the preceding paragraph should include additional experiments at these extreme conditions.

Methods and technical procedures

The methods and technical procedures for Activity 8.3.1.15.1.3.2 are given in the following table.

CONSULTATION DRAFT

Method	Technical procedure ^a		Date
	Number	Title	
Compression testing	TP-51	Procedure for determination of compressive mechanical properties	TBD ^b

^aTo the extent possible, nationally recognized procedures will be modified to conform to the requirements of the NNWSI Project Quality Assurance program when producing the procedure shown in the table.

^bTBD = to be determined.

8.3.1.15.1.3.3 Activity: Tensile strength of unit TSw2

Objectives

The objective of this activity is to obtain data on the tensile strength of unit TSw2. These data will contribute to the characterization of the mechanical behavior of unit TSw2, thus improving the quality of mechanical analyses and the interpretation thereof.

Parameters

The parameter for this activity is the tensile strength of intact rock.

Description

To more fully characterize the mechanical behavior of the proposed repository horizon, the tensile strength of unit TSw2 will be measured. Up to 20 experiments will be performed on material from the exploratory shaft. Preliminary evaluations of the response of the rock at Yucca Mountain to excavation and heat-induced loads (Sections 6.4 and 8.3.2.2) suggest that those instances where tensile strength of the rock is of interest primarily involve compressive-loading situations. For example, such loading situations might be expected to produce spalling around emplacement boreholes, which can be considered to be a tensile failure mechanism. Accordingly, the test technique selected for tensile testing will induce tensile failure through the application of a compressive load. A limited number of direct-pull tensile tests may be performed to examine load-dependent tensile strength variation. Appropriate sample sizes will be determined as detailed test plans develop.

Methods and technical procedures

The methods and technical procedures for Activity 8.3.1.15.1.3.3 are given in the following table.

CONSULTATION DRAFT

Method	Technical procedure ^a		Date
	Number	Title	
Tensile strength testing	TP-54	Procedure for determination of tensile mechanical properties	TBD ^b

^aTo the extent possible, nationally recognized procedures will be modified to conform to the requirements of the NNWSI Project QA program when producing the procedure shown in the table.

^bTBD = to be determined.

8.3.1.15.1.4 Study: Laboratory determination of the mechanical properties of fractures

The objective of this study is to provide laboratory characterization of the mechanical properties of fractures and the spatial variability thereof. The discussion applies for each new core hole and for the exploratory shaft (ES). Testing frequency at the main test level in the ES will depend on spatial variability.

8.3.1.15.1.4.1 Activity: Mechanical properties of fractures at baseline experiment conditions

Objectives

The objective of this activity is to obtain data for the mechanical properties of fractures, and the spatial variability thereof, for baseline experiment conditions. The data will be used in mechanical and thermo-mechanical calculations of the stresses and deformations induced by the presence of underground openings in unit TSw2 and overlying units and by the presence of heat-producing waste in unit TSw2.

Parameters

The parameters for this activity are cohesion, coefficient of friction, shear stiffness, normal stiffness.

Description

As discussed in Chapter 2, the mechanical behavior of fractures may be a function of various conditions, including displacement rate, temperature, mineralogy, sample size, fracture roughness, and saturation state. To evaluate the effects of these parameters, a set of baseline experimental conditions must be defined for which the parameters listed in this section will be obtained. These conditions will be as follows:

CONSULTATION DRAFT

Sample size: Diameters of approximately 51 to 114 mm

Saturation state: Dry

Temperature: 25°C

Displacement rate: 10 micrometers per second

Mineralogy: Devitrified, welded tuff with minimal secondary mineralization of fracture surfaces

This set of conditions applies for shear experiments. For measurement of normal stiffness, the conditions will be the same except that the loading rate will be approximately 0.03 MPa/s.

Sample size and mineralogy baseline conditions are preliminary and subject to reevaluation. Some natural fractures from the new core holes will be tested, but the sample size may differ from that eventually selected as the baseline size.

A similar difficulty exists for mineralogy of fractures. New core holes may or may not provide adequately preserved, intact samples of natural fractures representative of the differently mineralized surfaces to be found at Yucca Mountain.

Because of the limitations discussed above, most samples for fracture testing will be collected from the ES. Characterization of fracture orientations and mineralogy (Study 8.3.1.3.2.2) will help to determine what fractures will be tested. Emphasis will be placed on dominant fracture set(s), with some testing on less significant fractures as deemed necessary.

No data are presently available with which to estimate the number of fractures that must be tested. Scoping experiments are under way on samples from unit TSw2 collected from Busted Butte. These experiments will provide preliminary data that will be used to design the initial phase of fracture testing in terms of sampling frequency.

Methods and technical procedures

The methods and technical procedures for Activity 8.3.1.15.1.4.1 are given in the following table.

Method	Technical procedure		Date
	Number	Title	
Fracture testing	TP-52	Procedure for determination of fracture mechanical properties	TBD ^a

CONSULTATION DRAFT

Method	Technical procedure		Date
	Number	Title	
Fracture sampling	TBD	Procedure for obtaining representative samples of in situ fractures	TBD

^aTBD = to be determined.

8.3.1.15.1.4.2 Activity: Effects of variable environmental conditions on mechanical properties of fractures

Objectives

The objective of this activity is to evaluate the effects of varying displacement rate, saturation state, temperature, mineralogy, normal stress, and sample size on the mechanical properties of fractures. The data will be used in mechanical and thermomechanical calculations of stresses and deformations induced by the presence of underground openings in unit TSw2 and overlying units and by the presence of heat-producing waste in unit TSw2.

Parameters

The parameters of this activity are cohesion, coefficient of friction, shear stiffness, and normal stiffness.

Description

As stated for Activity 8.3.1.15.1.4.1, fracture characterization activities (Section 8.3.1.3.2.3) will identify dominant fracture set(s) in unit TSw2. These studies will be correlated with test results under varying experimental conditions to evaluate the sensitivity of the range of fracture properties to the conditions. Approximately 20 experiments will be performed at each experiment condition for samples of unit TSw2, with fewer experiments on samples of adjacent units if such experiments appear to be necessary. Tentative ranges in experiment conditions are as follows:

Saturation state: Dry and saturated
Temperature: 25 to 200°C
Normal stress: to be determined
Displacement rate: to be determined
Sample size: to be determined

In addition, several scoping experiments will be performed to examine whether creep is a realistic deformation mechanism for fractures in unit TSw2.

CONSULTATION DRAFT

The range in sample size (surface area) will depend on material availability. The range probably will extend from NX-core to cores up to 381 mm in diameter, and may include large, irregular samples as well. Sampling plans for this activity will take into account the importance of scaling effects when extrapolating from laboratory results to in situ fractures.

The range in mineralogy and roughness of fracture surfaces will depend on the results of characterization of fracture sets and sensitivity calculations. All types of fractures estimated to be of potential importance to the mechanical behavior of the rock mass will be tested.

Methods and technical procedures

The methods and technical procedures for Activity 8.3.1.15.1.4.2 are given in the following table.

Method	Technical procedure		Date
	Number	Title	
Fracture testing	TP-52	Procedure for determination of fracture mechanical properties	TBD ²
Fracture sampling	TBD	Procedure for obtaining representative samples of in situ fractures	TBD

²TBD = to be determined.

8.3.1.15.1.5 Study: Excavation investigations

The objective of this study is to obtain site-specific information concerning the behavior of underground excavations in the proposed repository horizon and overlying units. Most of the data will be used for validation of computer codes that will be used to predict mechanical behavior of the rock mass (Section 8.3.2.1.4). In addition, some of the information will serve as direct demonstration of constructability with reasonably available technology (relevant to resolution of Issue 4.4). All of the in situ experiments will be conducted in the exploratory shaft (ES) facility. Interpretation of the data to be obtained from the activities for this study (8.3.1.15.1.5) will utilize information gathered for 8.3.1.4.2.2 (characterization of structural features within the site area).

CONSULTATION DRAFT

8.3.1.15.1.5.1 Activity: Shaft convergence

Objectives

The objectives of this activity are to monitor rock-mass deformation around a vertical shaft (the ES) and to measure horizontal in situ stresses. In situ stress data will contribute to definition of boundary and initial conditions for mechanical and thermomechanical analyses, whereas observations of rock-mass deformation also will contribute to empirical evaluations of nonradiological health and safety (Issue 4.2).

Parameters

Information will be obtained concerning rock-mass deformation and horizontal in situ stress. Both will be obtained in more than one location (vertically), so that some information regarding spatial variability of rock-mass deformation and horizontal stresses will be obtained.

Description

The following description covers the monitoring of rock-mass deformation. In situ stress measurements are discussed in the next investigation (8.3.1.15.2).

Rock-mass deformation around the ES will be monitored at three levels using multiple-point borehole extensometers (MPBXs) placed at 120° intervals around the shaft circumference. The MPBXs will be installed as soon as practicable after excavation of the relevant level in the ES. Deformations will be measured across the shaft diameter and as a function of distance from the shaft at multiple locations in the walls. The MPBX heads will not be covered by the shaft liner, so that the deformations can be monitored as a function of time.

In addition to MPBX measurements, deformations will be measured with rod extensometers at each of the three levels. Extensometer measurements will be made along diameters in the same plane as the MPBXs at 60° from the MPBX heads.

Methods and technical procedures

The methods and technical procedures for Activity 8.3.1.15.1.5.1 are given in the following table.

CONSULTATION DRAFT

Method	Technical procedure		Date
	Number	Title	
Preparation of instrumentation holes	TP-1	Procedure for diamond-drilling holes for instrumentation	TBD ^a
	TP-2	Procedure for percussion-drilling holes for instrumentation	TBD
Overcoring stress measurements	TP-3	Procedure for overcoring for stress measurements	TBD
Biaxial stress measurements	TP-4	Procedure for biaxial stress measurements for overcoring testing	TBD
Rod extensometer measurements	TP-5	Procedure for installation operation of rod extensometers	TBD
MPBX ^b measurements	TP-6	Procedure for installation and operation of MPBXs	TBD
Borescope observation	TP-14	Procedure for borehole inspection using borescope	TBD
Use of borehole deformation gages	TP-17	Procedure for installation and operation of borehole deformation gages	TBD
Definition of joint properties	TP-23	Procedure for definition of joint properties and geometries	TBD
Monitoring of pressure control systems	TP-33	Procedure for monitored pressure control systems	TBD
Data acquisition	TP-34	Procedure for monitoring of data acquisition system	TBD

^aTBD = to be determined.

^bMPBX = multiple-point borehole extensometers.

CONSULTATION DRAFT

8.3.1.15.1.5.2 Activity: Demonstration breakout rooms

Objectives

The major objective of this activity is to demonstrate constructability and stability of underground rooms with cross-sectional dimensions equivalent to those of a repository in both lithophysae-rich and lithophysae-poor material. This demonstration will include an evaluation of the deformations that occur around the openings. A secondary objective is to provide facilities for other testing (e.g., heater tests and overcoring). Demonstration of constructability and stability will contribute to empirical evaluations of nonradiological health and safety (Issue 4.2).

Parameters

Data will be obtained concerning deformations caused by repository-sized excavations in welded tuff. Information also will be obtained about the extent of the zone of increased fracturing adjacent to the excavations, about rock-bolt loading, and observations about excavation efficiency.

Description

Two rooms with cross-sectional dimensions equivalent to those of a repository will be excavated, one in lithophysae-rich tuff (unit TSw1) and the second in lithophysae-poor material (unit TSw2). The rooms will be stabilized using rock bolts and wire mesh. Deformations will be monitored using multiple-point borehole extensometers (MPBXs) at two stations in each room, with 6 MPBXs at each station. Each MPBX will have 6 anchors. The MPBXs will be installed as soon as practicable after excavation of the relevant interval of the rooms. Rod extensometer measurements also will be made between drift convergence anchors in the room floor and back.

Methods and technical procedures

The methods and technical procedures for Activity 8.3.1.15.1.5.2 are given in the following table.

Method	Technical procedure		Date
	Number	Title	
Preparation of instrumentation holes	TP-1	Procedure for diamond-drilling holes for instrumentation	TBD ^a
	TP-2	Procedure for percussion-drilling holes for instrumentation	TBD
Rod extensometer measurements	TP-5	Procedure for operation of rod extensometers	TBD

CONSULTATION DRAFT

Method	Technical procedure		
	Number	Title	Date
MPBX ^b measurements	TP-6	Procedure for operation of MPBXs	TBD
Use of rock bolt load cells	TP-8	Procedure for installation and operation of rock bolt load cells	TBD
Borescope observation	TP-14	Procedure for borehole inspection using borescope	TBD
Definition of joint properties	TP-23	Procedure for definition of joint properties and geometries	TBD
Data acquisition	TP-34	Procedure for monitoring of data acquisition system	TBD
Rock bolt installation	TP-37	Procedure for installation of rock bolts	TBD
Blasted rock characterization	TP-38	Procedure for blasted rock sorting and size evaluation	TBD
Excavation activities	TP-41	Procedure for drilling and blasting	TBD
	TP-42	Procedure for loading and blasting	TBD

^aTBD = to be determined.

^bMPBX = multiple-point borehole extensometers.

8.3.1.15.1.5.3 Activity: Sequential drift mining

Objectives

The objectives of this activity are to obtain data on the deformation response of drifts with cross-sectional dimensions equivalent to those of a repository in welded tuff, to use the data in code validation activities, and to demonstrate constructability and stability of repository-sized drifts in lithophysae-poor material. Data will contribute to validation of computer codes to be used to calculate mechanical responses, as well as contributing

CONSULTATION DRAFT

to empirical evaluations related to nonradiological health and safety (Issue 4.2).

Parameters

Data will be obtained concerning deformations caused by the presence of multiple underground excavations in welded tuff (unit TSw2). Stress changes also will be monitored.

Description

Although a final design for this experiment is not available, the concept includes the following sequence:

1. Excavate an observation drift with cross-sectional dimensions smaller than or equivalent to those of a repository.
2. Instrument the rock mass in the direction of other excavation(s) planned for this experiment. Such excavation(s) will have cross-sectional dimensions equivalent to those of a repository.
3. Excavate other drift(s) or room(s).

Deformations caused by the excavation of secondary drifts in step 3 will be measured from the observation drift using borehole deflectometers and multiple-point borehole extensometers (MPBXs), and within the secondary drifts using rod extensometers and MPBXs. Instrumentation will be installed for step 2 and also will be placed in the secondary excavation(s) in step 3 as mining progresses. Changes in near-field stresses around the drifts will be monitored with borehole stressmeters.

Quantitative information from the measurements will be used to aid in validation of computer codes to be used in calculation of the mechanical response of the rock-mass. Additional discussions of code validation activities are presented in Section 8.3.2.1.4. Before this site characterization experiment begins, some prototype experiments will be performed in G-tunnel. These initial experiments are designed to aid in development of appropriate instrumentation. Emphasis will be placed on the development of geophysical instruments to monitor ground motion (acceleration, velocity, and stress) associated with blasting activities in welded tuff, with application to the possible survivability of the full range of instrumentation to be used in site characterization activities in the ESF.

Methods and technical procedures

The methods and technical procedures for Activity 8.3.1.15.1.5.3 are given in the following table.

CONSULTATION DRAFT

Method	Technical procedure		Date
	Number	Title	
Preparation of instrumentation holes	TP-1	Procedure for diamond-drilling holes for instrumentation	TBD ^a
	TP-2	Procedure for percussion-drilling holes for instrumentation	TBD
Rod extensometer measurements	TP-5	Procedure for operation of rod extensometers	TBD
MPBX ^b measurements	TP-6	Procedure for installation and operation of MPBXs	TBD
Use of rock bolt load cells	TP-8	Procedure for installation and operation of rock bolt load cells	TBD
Borehole deflectometer measurements	TP-10	Procedure for installation and operation of borehole deflectometer	TBD
Borehole stress meter measurements	TP-11	Procedure for installation and operation of borehole stress meters	TBD
Use of water permeability equipment	TP-13	Procedure for installation and operation of water permeability equipment	TBD
Borescope observation	TP-14	Procedure for borehole inspection using borescope	TBD
Definition of joint properties	TP-23	Procedure for definition of joint properties and geometries	TBD
Data acquisition	TP-34	Procedure for monitoring of data acquisition system	TBD

CONSULTATION DRAFT

Method	Technical procedure		Date
	Number	Title	
Rock bolt installation	TP-37	Procedure for installation of rock bolts	TBD
Evaluation of blasted rock	TP-38	Procedure for blasted rock sorting and size evaluation	TBD
Excavation activities	TP-41	Procedure for drilling and blasting	TBD
	TP-42	Procedure for loading and blasting	TBD

^aTBD = to be determined.

^bMPBX = multiple-point borehole extensometers.

8.3.1.15.1.6 Study: In situ thermomechanical properties

The objective of this study is to obtain data on in situ thermal and thermomechanical properties for units TSw1 and TSw2. Properties to be obtained include heat capacity, thermal conductivity, and thermal expansion. Deformation modulus, strain ratio, and radon emanation rates also will be determined during some of the testing activities. In addition, the effects of heating on in situ water content, deformation modulus, changes in thermally induced stress, radon emanation, and the deformation response of the rock around a heated room will be observed. Some of the data will be used for validation of computer codes used in heat transfer and thermomechanical calculations. Additional heater experiments will be conducted to characterize the waste container environment, as discussed in Section 8.3.4.2.4.

Interpretation of the data to be obtained from the activities for this study will utilize information gathered for Study 8.3.1.4.2.2 (characterization of the structural features within the site area).

8.3.1.15.1.6.1 Activity: Heater experiment in unit TSw1

Objectives

The objectives of this activity are to estimate the in situ thermomechanical properties of lithophysae-rich tuff (unit TSw1) and to observe the thermal and mechanical response of this tuff unit to elevated temperatures.

CONSULTATION DRAFT

The data will be used in thermal and mechanical calculations, to evaluate expected in situ behavior at elevated temperatures.

Parameters

The parameters of this study are thermal conductivity, heat capacity, and thermal expansion coefficient.

Description

The design of this experiment, in terms of heater dimensions and power output, has not been finalized. However, data to be measured will include temperatures, deformations, and changes in moisture content regardless of the heater used. Use of heater-induced temperature changes to estimate in situ values of thermal conductivity and heat capacity is discussed for Study 8.3.1.15.1.1. A neutron probe will be used to evaluate changes in bulk moisture content near the heater; this information will be used in calculation of in situ thermal properties and in qualitative evaluation of hydrothermal mechanisms. Estimates of thermal expansion coefficients will be obtained through a combination of the measured temperatures and thermally induced deformations as measured with multiple-point borehole extensometers.

Methods and technical procedures

The methods and technical procedures for Activity 8.3.1.15.1.6.1 are given in the following table.

Method	Technical procedure		
	Number	Title	Date
Preparation of instrumentation hole	TP-1	Procedure for diamond-drilling holes for instrumentation	TBD ^a
	TP-2	Procedure for percussion-drilling holes for instrumentation	TBD
MPBX ^b measurements	TP-6	Procedure for installation and operation of MPBXs	TBD
Borescope observation	TP-14	Procedure for inspection of boreholes using a borescope	TBD
Temperature measurements	TP-24	Procedure for installation and operation of thermocouples	TBD

CONSULTATION DRAFT

Method	Technical procedure		Date
	Number	Title	
Heater operation	TP-26	Procedure for installation and operation of small-scale heater	TBD
	TP-27	Procedure for installation and operation of canister-scale heaters	TBD
Data acquisition	TP-34	Procedure for monitoring of data acquisition system	TBD
Heater control	TP-35	Procedure for monitoring of temperature or heater control systems	TBD
Moisture measurements	TP-39	Procedure for installation and operation of neutron probe for determination of moisture content	TBD
Heater operation	TBD	TBD	TBD

^aTBD = to be determined.

^bMPBX = multiple-point borehole extensometers.

8.3.1.15.1.6.2 Activity: Canister-scale heater experiment

Objectives

The objectives of this activity are to estimate the in situ thermo-mechanical properties of lithophysae-poor tuff (unit TSw2) to (1) evaluate the thermomechanical behavior of welded tuff around a canister-scale emplacement borehole, and (2) use the data in validation of thermal and thermo-mechanical computer codes.

Parameters

The parameter to be determined for this activity is the thermal expansion coefficient.

CONSULTATION DRAFT

Description

A canister-scale heater will be emplaced in unit TSw2, and temperatures, deformations, and changes in moisture content and stresses will be monitored. Instrumentation will include thermocouples, multiple-point borehole extensometers (MPBXs), borehole deformation gauges, and a neutron probe. The use of heater-induced temperature changes to estimate in situ values of thermal conductivity and heat capacity is discussed for Study 8.3.1.15.1.1. Estimates of thermal expansion coefficients will be obtained through combination of the measured temperatures and thermally induced deformations as measured with the MPBXs. Quantitative information will be used in validation of computer codes used to calculate thermal and thermomechanical behavior of the rock mass. Values for rock-mass thermal properties will be obtained from evaluation of rock mass response and from estimates based on laboratory measurements of samples obtained from the vicinity of the canister-scale heater. Additional discussion of code validation activities is presented in Section 8.3.2.1.4. Qualitative information concerning stability of the heater hole under conditions of elevated temperature will contribute to evaluation of retrievability.

An activity associated with the canister-scale experiment is the measurement of radon emissions in unit TSw2 as a function of temperature. A borehole near the heater will be monitored for radon concentrations throughout the duration of the canister-scale experiment. Results will be used to satisfy Issue 2.7 (Section 8.3.2.3).

Methods and technical procedures

The methods and technical procedures for Activity 8.3.1.15.1.6.2 are given in the following table.

Method	Technical procedure		Date
	Number	Title	
Preparation of instrumentation holes	TP-1	Procedure for diamond-drilling holes for instrumentation	TBD ^a
	TP-2	Procedure for percussion-drilling holes for instrumentation	TBD
MPBX ^b measurements	TP-6	Procedure for installation and operation of MPBXs	TBD
Borescope observations	TP-14	Procedure for inspection of boreholes using a borescope	TBD

CONSULTATION DRAFT

Method	Technical procedure		Date
	Number	Title	
Borehole deformation gage measurements	TP-17	Procedure for installation and operation of borehole deformation gages	TBD
Temperature measurements	TP-24	Procedure for installation and operation of thermocouples	TBD
Heater operation	TP-27	Procedure for installation and operation of canister-scale heater	TBD
Radon measurements	TP-28	Procedure for installation and operation of instrumentation for monitoring radon emanations	TBD
Data acquisition	TP-34	Procedure for monitoring of data acquisition system	TBD
Heater control	TP-35	Procedure for monitoring of temperature or heater control systems	TBD
Moisture measurements	TP-39	Procedure for installation and operation of neutron probe for determination of moisture content	TBD

^aTBD = to be determined.

^bMPBX = multiple-point borehole extensometers.

8.3.1.15.1.6.3 Activity: Yucca Mountain heated block

Objectives

The objectives of this activity are to estimate in situ mechanical and thermomechanical properties of unit TSw2 and to validate thermomechanical computer models. Data on the properties will be used in mechanical and thermomechanical calculations of stresses and deformations induced by the

presence of underground openings in unit TSw2 and overlying units and by the presence of heat-producing waste in unit TSw2.

Parameters

The parameters of this activity are deformation modulus, thermal expansion coefficient, thermal conductivity, heat capacity, joint wall compressive strength, and joint roughness coefficient.

Description

Slots isolating a 2- by 2-m block will be cut in an alcove at the main test level in the exploratory shaft (ES). Flatjacks will be set in the slots adjacent to the block, enabling application of uniaxial or biaxial stresses. Two rows of heaters outside opposite sides of the block will be used to heat the block. Before and during the heated phases, stresses will be applied and deformation will be monitored to obtain values for the deformation modulus and the ratio of lateral strain to axial strain (principal strain ratio), and the variation of these two properties with temperature. Thermally induced deformation will be used to obtain estimates of the thermal expansion coefficient. Use of heater-induced temperature changes to estimate in situ values of thermal conductivity and heat capacity is discussed for Study 8.3.1.15.1.1. A thermal probe also will be used as a transient-line heat source to measure in situ thermal conductivity directly. In addition to the parameters mentioned previously, changes in moisture content as a function of temperature and position will be monitored with a neutron probe.

After some portion of the experiment has been accomplished for this activity, the feasibility of cutting slots for a second block will be assessed. If feasible, this block would be oriented in a manner allowing for measuring shear and normal mechanical properties of in situ fractures (Activity 8.3.1.15.1.7.2). No heat would be involved.

Instrumentation for measuring deformation for this activity may include set pins, strain gage rosettes, horizontal extensometers, tiltmeters, and multiple-point borehole extensometers. Stress changes during the experiment will be monitored with borehole deformation gages. As mentioned earlier, thermal and neutron probes also will be used.

To help interpret the data from this experiment, laboratory measurements will be made using core from instrumentation holes in or near the block. Thermal conductivity, heat capacity, and mechanical properties will be measured. In addition, measurements of joint wall compressive strength and joint roughness coefficient (Barton and Choubey, 1977) will be made on joints near the location of the block.

Methods and technical procedures

The methods and technical procedures for Activity 8.3.1.15.1.6.3 are given in the following table.

CONSULTATION DRAFT

Method	Technical procedure		Date
	Number	Title	
Preparation of instrumentation holes	TP-1	Procedure for diamond-drilling holes for instrumentation	TBD ^a
	TP-2	Procedure for percussion-drilling holes for instrumentation	TBD
MPBX ^b measurements	TP-6	Procedure for installation and operation of MPBXs	TBD
Slot cutting	TBD	TBD	TBD
Borehole deformation gage measurements	TP-17	Procedure for installation and operation of borehole deformation gages	TBD
Whittemore pin measurements	TP-19	Procedure for installation and operation of Whittemore pins	TBD
Strain gage measurements	TP-20	Procedure for installation and operation of surface strain gages	TBD
Tiltmeter measurements	TP-21	Procedure for installation and operation of tiltmeters	TBD
Flatjack operation	TP-22	Procedure for installation and operation of flatjacks	TBD
Fracture characterization	TP-23	Procedure for characterization of fracture properties and geometry	TBD
Temperature measurements	TP-24	Procedure for installation and operation of thermocouples	TBD
Thermal probe measurements	TP-25	Procedure for installation and operation of thermal probe	TBD

CONSULTATION DRAFT

Method	Technical procedure		Date
	Number	Title	
Heater operation	TP-26	Procedure for installation and operation of small-scale heaters	TBD
Data acquisition	TP-34	Procedure for monitoring of data acquisition system	TBD
Heater control	TP-35	Procedure for monitoring of temperature or heater control systems	TBD
Moisture measurements	TP-39	Procedure for installation and operation of neutron probe for determination of moisture content	TBD

^aTBD = to be determined.

^bMPBX = multiple-point borehole extensometer.

8.3.1.15.1.6.4 Activity: Thermal stress measurements

Objectives

The objective of this activity is to monitor changes in thermally induced stress in jointed welded tuffs. The data will be used to evaluate validity of thermally induced stresses calculated with thermomechanical computer codes.

Parameters

The parameter for this activity is thermally induced stress.

Description

A slot will be cut in the roof or a rib of a drift and a flatjack will be inserted in the slot. Two rows of heaters parallel to and on either side of the slot will be energized, and the method of stress cancellation will be used to measure the stresses induced by the temperature field. In addition, deformation in the surrounding heated volume ($>36 \text{ m}^3$) will be monitored using MPBXs and long-gage-length displacement extensometers. Combination of measured deformation with measured temperatures will allow confirmation of in situ thermal expansion coefficients measured in other in situ tests (Activities 8.3.1.15.1.6.1, 8.3.1.15.1.6.2, and 8.3.1.15.1.6.3).

CONSULTATION DRAFT

The specific number and location of these experiments has not yet been defined. Evaluation of the experimental design and prototype experiments are ongoing. The prototype experiments include development of equipment (e.g., high-pressure flatjacks) as well as methodology.

Methods and technical procedures

The methods and technical procedures for Activity 8.3.1.15.1.6.4 are given in the following table.

Method	Technical procedure		
	Number	Title	Date
Preparation of instrumentation holes	TP-1	Procedure for diamond-drilling holes for instrumentation	TBD ^a
	TP-2	Procedure for percussion-drilling holes for instrumentation	TBD
MPBX ^b measurements	TP-6	Procedure for installation and operation of MPBXs	TBD
Slot cutting	TBD	TBD	TBD
Long-gage extensometer measurements	TP-18	Procedure for installation and operation of long-gage length displacement extensometers	TBD
Flatjack operation	TP-22	Procedure for installation and operation of flatjacks	TBD
Temperature measurements	TP-24	Procedure for installation and operation of thermocouples	TBD
Heater operation	TP-26	Procedure for installation and operation of small-scale heaters	TBD
Data acquisition	TP-34	Procedure for monitoring of data acquisition system	TBD

CONSULTATION DRAFT

Method	Technical procedure		Date
	Number	Title	
Heater control	TP-35	Procedure for monitoring of temperature or heater control systems	TBD
Stress cancellation testing	TP-79	Procedure for measurement of in situ slot normal stress in the field	TBD

^aTBD = to be determined.

^bMPBX = multiple-point borehole extensometer.

8.3.1.15.1.6.5 Activity: Heated room experiment

Objectives

The objectives of this activity are (1) to estimate the in situ thermo-mechanical properties of densely welded, fractured tuff (unit TSw2), (2) to evaluate the thermomechanical behavior of welded tuff around repository openings, (3) to develop a data base for evaluating thermal and thermo-mechanical computer codes, and (4) to use the data in evaluating drift response to expected repository conditions during both construction and operation.

Parameters

The following parameters and information will be obtained during this experiment: rock mass deformation; estimate of the region in which the stress state is changed by elevation of temperature; rib stress change; thermal conductivity and heat capacity; ground-support loading and deformation; and the temperature dependence of measured parameters.

Description

The design of this experiment has not yet been completed. The experiment will be conducted in unit TSw2. The experiment will consist of developing a representative drift (cross section) and heating the rock around it to expected repository operating temperatures. The length of the drift and geometrical placement of the heat sources will be determined by optimizing the length and heat source placement with a reasonable number of heaters required to generate repository-like conditions. Either a preexisting drift will be used or a drift will be constructed specifically for this experiment. The drift will be instrumented appropriately to provide data for the parameters described previously. The experiment may involve more than one opening so that the temperatures around and between drifts more nearly correspond to those expected in the repository. The experiment will be

CONSULTATION DRAFT

initiated during site characterization and will continue into the performance confirmation period.

Methods and technical procedures

The methods and technical procedures for Activity 8.3.1.15.1.6.5 are given in the following table.

Method	Technical procedure		Date
	Number	Title	
Preparation of instrumentation holes	TP-1	Procedure for diamond drilling holes for instrumentation	TBD ^a
Preparation of instrumentation holes	TP-2	Procedure for percussion drilling holes for instrumentation	TBD
Rod extensometer measurements	TP-5	Procedure for rod extensometer installation and operation	TBD
MPBX ^b measurements	TP-6	Procedure for MPBX installation and operation	TBD
Use of rock bolt load cells	TP-8	Procedure for rock bolt load cell installation and operation	TBD
Use of borehole deflectometer	TP-10	Procedure for borehole deflectometer installation and operation	TBD
Use of borehole stressmeter	TP-11	Procedure for borehole stressmeter installation and operation	TBD
Borescope observation	TP-14	Procedure for borehole inspection using borescope	TBD
Use of borehole deformation gages	TP-17	Procedure for borehole deformation gage installation and operation	TBD

CONSULTATION DRAFT

Method	Technical procedure		Date
	Number	Title	
Use of tiltmeters	TP-21	Procedure for tiltmeter installation and operation	TBD
Definition of joint properties	TP-23	Procedure for definition of joint properties and geometries	TBD
Use of thermocouples	TP-24	Procedure for thermocouple installation and operation	TBD
Use of thermal probe	TP-25	Procedure for thermal probe installation and operation	TBD
Heater operation	TP-26	Procedure for installation and operation of small-scale heaters	TBD
	TP-27	Procedure for installation and operation of canister-scale heaters	TBD
Radon measurements	TP-28	Procedure for radon and radon-daughter measurement instrumentation installation and operation	TBD
Acoustic emission observation	TP-29	Procedure for acoustic emission instrumentation installation and operation	TBD
Monitoring of pressure control systems	TP-33	Procedure for monitored pressure control systems	TBD
Data acquisition	TP-34	Procedure for data acquisition system monitoring	TBD
Monitoring of temperature control systems	TP-35	Procedure for monitored temperature or heater control systems	TBD

CONSULTATION DRAFT

Method	Technical procedure		Date
	Number	Title	
Rockbolt installation	TP-37	Procedure for rockbolt installation	TBD
Use of neutron probe	TP-39	Procedure for neutron probe installation and operation for moisture measurements	TBD
or	TP-40	Procedure for neutron probe installation and operation for density measurements	TBD

^aTBD = to be determined.

^bMPBX = multiple-point borehole extensometer.

8.3.1.15.1.7 Study: In situ mechanical properties

The objectives of this study are to obtain in situ measurements of the mechanical properties of the rock mass for unit TSw2. The numbers of experiments to obtain such properties will be insufficient to satisfy requirements for confidence as expressed by performance and design issues. Therefore, the data will be used as preliminary indicators of rock-mass values and as checks of the validity of extrapolation of laboratory-determined data to in situ conditions. In addition, measurements of rock-mass deformation modulus in different locations will provide an estimate of spatial variability of rock-mass mechanical properties. Necessary information about fractures that is relevant to individual test locations (as well as to Yucca Mountain as a whole) will be gathered as part of Study 8.3.1.4.2.2.

8.3.1.15.1.7.1 Activity: Plate loading tests

Objectives

The objectives of this activity are to measure the deformation modulus of the rock mass and to evaluate the zone of increased fracturing adjacent to underground openings. Modulus data are to be used in thermomechanical calculations of the stresses and deformations induced by the presence of underground openings in unit TSw2 and overlying units and by the presence of heat-producing waste in unit TSw2. Characterization of the zone of increased

CONSULTATION DRAFT

fracturing will contribute to the definition of initial conditions, boundary conditions, and properties to be used in the calculations.

Parameters

The parameters for this activity are rock-mass deformation modulus, joint wall compressive strength, joint roughness coefficient, and spatial variability thereof.

Description

Plate-loading experiments will be performed at numerous (10-20) locations in the exploratory shaft facility and associated excavations both in unit TSw1 (upper demonstration breakout room) and in unit TSw2 at the main test level. Individual experiments will be performed with vertical and horizontal orientations at each location. Rock deformations will be measured using a multiple-point borehole extensometer (MPBX) oriented parallel to the load axis in the center of the plate area. Deformation of the loading column will be monitored using rod extensometers. Values of the rock deformation modulus will be calculated using the rock deformation and the applied stresses. Moduli from different stations will be compared to evaluate spatial variability within unit TSw2. These data primarily will be applicable to the material around an opening that has been affected by the presence of the opening and by the excavation process. As such, the moduli will represent lower bounds on the modulus of the undisturbed rock mass.

Borehole dilatometer measurements performed in association with over-coring experiments (Activity 8.3.1.15.2.1.2) will be used to obtain data on the borehole deformation modulus. These data will provide another measure of the spatial variability of in situ moduli.

To aid in the interpretation of data obtained from these experiments, mechanical properties of the intact rock will be measured in the laboratory using core from instrumentation holes at each experiment location. In addition, joint wall compressive strength and joint roughness coefficient (Barton and Choubey, 1977) and joint geometry will be measured on joints near each experiment location. Frictional and stiffness properties of the joints may be used in the analysis of the plate-loading experiments. Such properties will be measured on site-specific samples if samples can be obtained. If no site-specific samples are available, data will be taken from the results of Activities 8.3.1.15.1.4.1 and 8.3.1.15.1.4.2.

Methods and technical procedures

The methods and technical procedures for Activity 8.3.1.15.1.7.1 are given in the following table.

CONSULTATION DRAFT

Method	Technical procedure		Date
	Number	Title	
Preparation of instrumentation holes	TP-1	Procedure for diamond-drilling holes for instrumentation	TBD ^a
	TP-2	Procedure for percussion-drilling holes for instrumentation	TBD
Rod extensometer measurements	TP-5	Procedure for installation and operation of extensometers	TBD
MPBX ^b measurements	TP-6	Procedure for installation and operation of MPBXs	TBD
Borescope observation	TP-14	Procedure for inspection of boreholes using borescope	TBD
Flatjack operation	TP-22	Procedure for installation and operation of flatjacks	TBD
Definition of joint properties	TP-23	Procedure for definition of joint properties and geometries	TBD
Monitoring pressure control systems	TP-33	Procedure for monitoring pressure control systems	TBD
Data acquisition	TP-34	Procedure for monitoring of data acquisition system	TBD
Borehole dilatometer	TBD	Borehole dilatometer testing	TBD

^aTBD = to be determined.

^bMPBX = multiple-point borehole extensometer.

CONSULTATION DRAFT

8.3.1.15.1.7.2 Activity: Rock-mass strength experiment

Objectives

The objectives of this activity are to estimate the strength of the rock mass or its components; to develop scaling relationships between laboratory and expected in situ conditions; to provide data to evaluate empirical design criteria; and to provide data to evaluate and validate jointed-rock models.

Parameters

The following parameters and information will be obtained during this experiment: joint characteristics, including load response characteristics; joint shear strength (laboratory-to-field scale); rock-mass strength.

Description

As discussed previously in this section, the approach to defining the physical interpretation of rock-mass strength is still evolving. Thus, the design of this experiment has not yet been completed. Experiments will be conducted in several areas of the exploratory shaft facility (ESF). These areas have not been determined, but they will be chosen to be representative of the range of geologic conditions expected in the repository. Joint shear strength will be measured on samples of field-scale size where field scale is considered to be the expected in situ joint length. In addition, an experiment to evaluate the empirical rock-mass strength criterion developed by Hoek and Brown (1980) may be performed. This stage of the experiment would require a representative volume of randomly jointed rock to be loaded.

Methods and technical procedures

The methods and technical procedures for Activity 8.3.1.15.1.7.2 are given in the following table.

Method	Technical procedure		
	Number	Title	Date
Preparation of instrumentation holes	TP-1	Procedure for diamond drilling holes for instrumentation	TBD ^a
Preparation of instrumentation holes	TP-2	Procedure for percussion drilling holes for instrumentation	TBD
MPBX ^b measurements	TP-6	Procedure for installing and operating MPBXs	TBD

CONSULTATION DRAFT

Method	Number	Technical procedure	
		Title	Date
Boreoscope observations	TP-14	Procedure for inspecting boreholes using a boreoscope	TBD
Slot-cutting	TP-15, -16, -30, -31, -32	Procedure for slot-cutting with a chain saw	TBD
Use of long-gage surface extensometer	TP-18	Procedure for installation and operation of long-gage surface extensometer	TBD
Use of surface strain gages	TP-20	Procedure for installation and operation of surface strain gages	TBD
Use of flatjacks	TP-22	Procedure for installation and operation of flatjack in thin slots	TBD
Definition of joint properties	TP-23	Procedure for definition of joint properties and geometries	TBD
Acoustic emission measurements	TP-29	Procedure for installation and operation of acoustic emission instrumentation	TBD
Monitoring of pressure control systems	TP-33	Procedure for monitored pressure control systems	TBD
Data acquisition	TP-34	Procedure for monitoring the data acquisition system	TBD
Sampling methods	TP-45	Procedure for sampling methods	TBD

^aTBD = to be determined.

^bMPBX = multiple-point borehole extensometer.

CONSULTATION DRAFT

8.3.1.15.1.8 Study: In situ design verification

The objectives of this study are (1) to verify the adequacy of the design and operating procedures for the construction of the repository, (2) to evaluate long-term considerations for ground support, and (3) to assess the impact of site characteristics on the ventilation requirements necessary to provide a safe working environment. These objectives will be addressed through in situ measurements and observations in excavations at the main test level in the ESF. The work associated with this study will be closely coordinated with Study 8.3.1.15.1.1 through Study 8.3.1.15.1.7 particularly Study 8.3.1.15.1.5 (excavation investigations). Where possible, the data gathered in these other studies will be used to support the subject study (8.3.1.15.1.8). In all cases the activities described in this study are of a preliminary nature, and as such, may be revised prior to their implementation in the ESF.

8.3.1.15.1.8.1 Activity: Mining methods

Objectives

The objective of this activity is to demonstrate the mining methods for accesses and drifts with emphasis on the response of rock containing different lithophysae abundances or structural characteristics. Information from this activity will contribute to nonradiologic health and safety.

Parameters

Information will be obtained to evaluate selected mining methods (e.g., controlled blasting). Because the design of the experiment is preliminary, the actual parameters to be measured are uncertain at this time.

The preliminary objective of the construction monitoring is an evaluation of the influence of the mining methods on worker safety and ground support requirements. Monitoring will include the evaluation of the effects of blasting design, hole loading, and explosive type on safety and ground stability. Ancillary data to be gathered will include drill penetration rate, bit wear, cutter wear, blasting vibration and its effect on the ground support system, mining cycle times, bolt and dowel performance, size distribution and sorting of blast fractured rock, and angle of repose of piles of blast fractured rock. Results of the blasting will be used to develop specifications and operating procedures for blasting in the repository. The evaluation of the excavation technique will be repeated for each significantly different classification of ground encountered in the ESF. Preliminary information with regard to the excavation technique may be obtained during shaft construction, but the majority of the information will be obtained during construction of the ESF and associated lateral drifts.

Methods and technical procedures

The methods and technical procedures for Activity 8.3.1.15.1.8.1 given in the following table are preliminary. The list may change or be augmented as the design of this experiment is finalized.

CONSULTATION DRAFT

Method	Technical procedure		Date
	Number	Title	
Ground motion monitoring	TP-9	Procedure for installation and operation of accelerometers	TBD ^a
Definition of joint properties	TP-23	Procedure for definition of joint properties and geometries	TBD
Blasted rock characterization	TP-38	Procedure for blasted rock sorting and size evaluation	TBD
Excavation activities	TP-41	Procedure for drilling and blasting	TBD
	TP-42	Procedure for loading and blasting	TBD

^aTBD = to be determined.

8.3.1.15.1.8.2 Activity: Monitoring of ground-support systems

Objectives

The objectives of this activity are to (1) monitor the selection, installation, and response of ground-support systems in the repository level of the ESF and (2) perform preliminary evaluations of the procedures for the selection and installation of those systems for possible use in the repository. A number of different ground-support systems may be installed, because a variety of underground conditions may be encountered in the ESF (including the associated long lateral drifts). Each support system that is used will be monitored and evaluated. Some of the data obtained in Study 8.3.1.15.1.5 (excavation investigation) will be used for evaluating the support system(s) in the drifts associated with that study. Information on ground-support systems is related to nonradiologic health and safety.

Parameters

During monitoring of the selection of ground-support systems, information that is used for the selection (e.g., rock quality designation (RQD), compressive strength, joint geometry, and in situ stress) will be compiled. This information will be produced in other studies, such as 8.3.1.15.1.3, 8.3.1.4.2.2, and 8.3.1.15.2.1. RQD is not an unique characterization parameter, but is obtained from logging of core associated with such studies as 8.3.1.4.2.1 and 8.3.1.4.3.1. During the monitoring of the installation

CONSULTATION DRAFT

and response of the support systems, data relative to the following may be gathered: rock-bolt load history, stresses (on rock, shotcrete, and/or concrete) and displacements. The timing and implementation of the procedures used in installing the support systems will also be monitored.

Description

Although the detailed design of this activity has not been completed, the phases of the monitoring are well established. During the ground-support selection phase, this activity is primarily one of compiling information (i.e., monitoring a necessary selection process). Although a single type of ground-support system (e.g., rock bolts with wire mesh) may be selected for most of the repository level of the ESF, other systems, such as those that use shotcrete and reinforced concrete, may be required in some areas. Each of the support systems that is installed will be monitored and the monitoring will be tailored to the particular type of support system.

The support performance monitoring phase is likely to include measurement of convergence, loads on rock bolts (where used), and stresses in rock, concrete, or shotcrete (as appropriate). The monitoring will be performed on drifts that are repository size (where possible) and along a sufficient length to adequately evaluate the support system performance. Instrumentation will include extensometers and load cells. The particular types of instruments will depend on the type of support system and the instrumentation design requirements.

In the assessment phase the performance of the installed ground-support systems will be partially evaluated for potential use in the repository. Because the areas that will be monitored will not, in general, be heated, the complete evaluations will require data from other thermal/mechanical studies (e.g., Study 8.3.1.15.1.6). It should also be recognized that although an appropriate selection process will lead to an adequate ground-support system, assessing whether a reduced system (e.g., rock bolts only instead of rock bolts and wire mesh) would be adequate for use in the repository will generally not be possible from monitoring alone. Therefore, the complete evaluation of ground-support systems is a complex process that includes empirical methods, analyses, and data from many sources. A complete evaluation is a design analysis process that is beyond the scope of this study.

Methods and technical procedures

The methods and technical procedures for Activity 8.3.1.15.1.8.2 will evolve as the detailed design of the activity is accomplished. The list given in the following table is preliminary.

CONSULTATION DRAFT

Method	Technical procedure		Date
	Number	Title	
Preparation of instrumentation holes	TP-1	Procedure for diamond-drilling holes for instrumentation	TBD ^a
	TP-2	Procedure for percussion drilling holes for instrumentation	TBD
Rod extensometer	TP-5	Procedure for installation measurements and operation of rod extensometers	TBD
MPBX ^b measurements	TP-6	Procedure for installation operation of MPBXs	TBD
Use of rock-bolt load cells	TP-8	Procedure for installation and operation of rock-bolt load cells observation	TBD
	TP-14	Procedure for borehole inspection using a borescope	TBD
Definition of joint properties	TP-23	Procedure for definition of joint properties and geometries	TBD
Rock bolt installation	TP-37	Procedure for installation rock bolts	TBD
Determination of RQD ^c	TP-72	Procedure for determination of RQD	TBD

^aTBD = to be determined.

^bMPBX = multiple-point borehole extensometer.

^cRQD = rock quality designation.

8.3.1.15.1.8.3 Activity: Monitoring drift stability

Objectives

The objective of this activity is to monitor drift convergence throughout the ESF. The intention is not to evaluate support performance, per se, as in Activity 8.3.1.15.1.8.2, but rather to provide information regarding

CONSULTATION DRAFT

potential instabilities throughout the ESF. This information will contribute to empirical evaluations related to nonradiological health and safety.

Parameters

Information will be obtained concerning rock displacement.

Description

The design of the experiment described in this activity is preliminary and subject to change. Drift monitoring will be performed at many locations within the entire ESF to assess potential instabilities. Monitoring will be performed at many stations (or, if practical, in a continuous manner). Measurement stations will include convergence, and, perhaps, stress measurements. In addition, visual observation will be used to assist in delineating areas of potential instability.

Methods and technical procedures

The methods and technical procedures for Activity 8.3.1.15.1.8.3 given in the following table are preliminary. The list may change or be augmented as the design of this experiment is finalized.

Method	Technical procedure		
	Number	Title	Date
Preparation of instrumentation holes	TP-1	Procedure for diamond-drilling holes for instrumentation	TBD ^a
	TP-2	Procedure for percussion drilling holes for instrumentation	TBD
Rod extensometer measurements	TP-5	Procedure for operation of rod extensometers	TBD
Use of rock bolt load cells	TP-8	Procedure for installation and operation of rock bolt load cells	TBD
Borescope observation	TP-14	Procedure for borehole inspection using a borescope	TBD

^aTBD = to be determined.

CONSULTATION DRAFT

8.3.1.15.1.8.4 Activity: Air quality and ventilation experiment

Objectives

The objective of this activity is to assess the impact of site characteristics on the ventilation requirements necessary to provide a safe working environment. This information will contribute to empirical evaluations related to nonradiological health and safety.

Parameters

Information will be obtained relative to air resistance factors, formation gas types, and dust types and generation rates.

Description

The description of the experiment described in this activity has not been finalized and may change. The parameters required to properly design the ventilation system should be determined through measurements taken during the initial ESF construction and at random locations throughout the ESF and associated lateral drifts. The air resistance factors will be determined as a function of wall roughness for the different rock types, construction methods, and support systems. The surface emission rates for the various types of gases present (including radon) will be determined as a function of the time after excavation, surface exposure, and temperature throughout the ESF. The dust generation rates will be determined for the different types and qualities of rock encountered throughout the ESF. Rock chemistry will be evaluated using information produced in Study 8.3.1.3.2.1 in order to estimate the potential for generation of hazardous particulates during drilling and mining, and to estimate the potential for radon emanation. Also, information on bulk permeability of the host rock will be compiled from studies such as 8.3.1.2.2.4, for evaluation of potential leakage between mining ventilation and waste emplacement ventilation systems in the repository.

Methods and technical procedures

The methods and technical procedures for Activity 8.3.1.15.1.8.4 given in the following table are preliminary. The list may change or be augmented as the design of this experiment is finalized.

Method	Technical procedure		Date
	Number	Title	
Preparation of instrumentation holes	TP-1	Procedure for diamond-drilling holes for instrumentation	TBD ^a
	TP-2	Procedure for percussion drilling holes for instrumentation	TBD

CONSULTATION DRAFT

Method	Technical procedure		Date
	Number	Title	
Radon measurements	TP-28	Procedure for installation and operation of instrumentation for monitoring radon emanations	TBD
Dust monitoring	TBD	Procedure for monitoring dust that is generated during the mining of drifts.	TBD
Gas measurements	TBD	Procedure for monitoring carbon monoxide and nitrous oxides	TBD
Air velocity measurements	TBD	Procedure for monitoring ventilation velocity	TBD
Air moisture measurements	TBD	Procedure for monitoring intake and exhaust moisture content	TBD

^aTBD = to be determined.

8.3.1.15.1.9 Application of results

The information obtained from the studies and activities described in the preceding sections will be used in the resolution of the issues listed in Table 8.3.1.15-1. As discussed earlier, the process may be an interactive one, so that interaction between testing, performance assessment, and design functions may be necessary before the investigation is complete. Data will be used in computer analyses of thermal and mechanical responses of the rock mass to a repository, as well as in more empirical evaluations of such topics as required ground support and stand-up time of underground openings.

8.3.1.15.1.10 Schedule and milestones

This investigation addressing spatial distribution of thermal and mechanical properties, contains eight studies: 8.3.1.15.1.1 (laboratory thermal properties), 8.3.1.15.1.2 (laboratory thermal expansion testing), 8.3.1.15.1.3 (determination of mechanical properties of intact rock), 8.3.1.15.1.4 (determination of mechanical properties of fractures),

CONSULTATION DRAFT

8.3.1.15.1.5 (excavation investigations), 8.3.1.15.1.6 (in situ thermo-mechanical properties), 8.3.1.15.1.7 (in situ mechanical properties), and 8.3.1.15.1.8 (in situ design verification). In the figure that follows, the schedule information for these studies is presented in the form of timelines. The timelines extend from implementation of the approved study plans to the issuance of the final products associated with the studies. Summary schedule and milestone information for this investigation can be found in Section 8.5.1.1. Section 8.5.1.2 presents additional schedule information for exploratory shaft activities.

One study in this investigation (8.3.1.15.1.3) is ongoing. Three studies (8.3.1.15.1.1, 8.3.1.15.1.2, and 8.3.1.15.1.4) are planned to begin within the first year of site characterization. Studies 8.3.1.15.1.6 and 8.3.1.15.1.7 are out-year studies and Studies 8.3.1.15.1.5 and 8.3.1.15.1.8 are linked directly to the construction phase of the exploratory shaft.

The work in this investigation is to provide the required information for spatial distribution of thermal and mechanical properties. Laboratory and in situ data will be acquired and evaluated for input into the license application design.

Studies 8.3.1.15.1.1, 8.3.1.15.1.2, 8.3.1.15.1.3 and 8.3.1.15.1.4 involve laboratory testing of core samples and are partly constrained by the availability of samples from Study 8.3.1.4.3.1. While this interface does not completely constrain these laboratory studies, it will provide a significant portion of the samples used. These studies also involve laboratory testing of samples acquired from core taken in the exploratory shaft facility (ESF). The remaining four studies involve geomechanical tests, observations, and evaluations in the ESF and, therefore, are constrained by the excavation schedule.

The study numbers and titles corresponding to the timelines are shown on the left of the following figure. The points shown on the timelines represent major events or important milestones associated with the study. Solid lines represent study durations, and dashed lines show interfaces. The data input and output at the interfaces are shown by circles.

The points on the timeline and the data input and output at the interfaces are described in the following table:

<u>Point number</u>	<u>Description</u>
1	Input of Phase I performance assessment drilling (8.3.1.4.3).
2	Issue final reports on densities and porosities, heat capacities and thermal conductivities of samples from new core holes.
3	Milestone M058. Issue final report on the thermal, thermo-mechanical, and mechanical properties of material from shaft construction.

CONSULTATION DRAFT

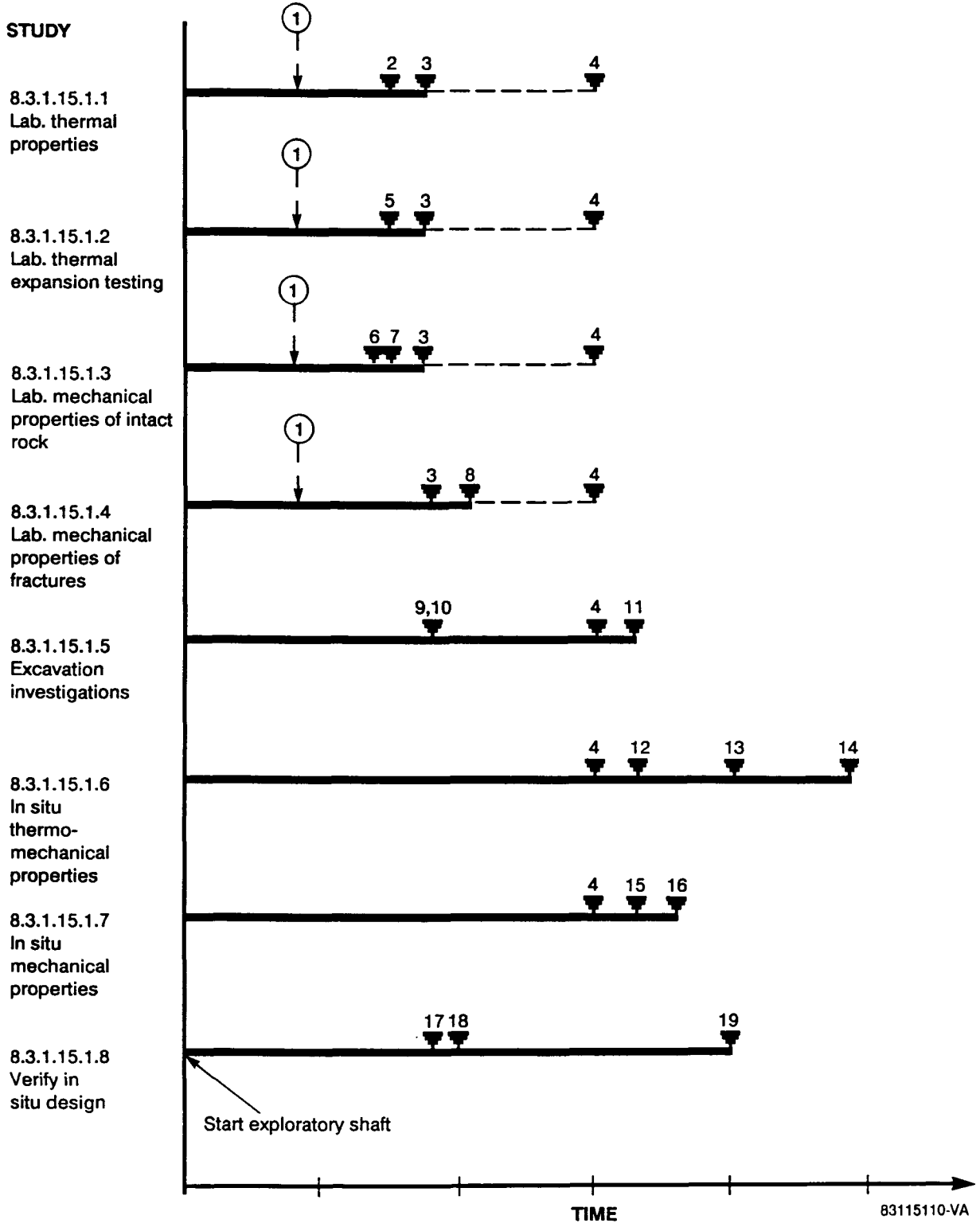

CONSULTATION DRAFT

<u>Point number</u>	<u>Description</u>
4	Milestone M445. Update document on thermomechanical properties for license application design.
5	Issue final report on thermal expansion of samples from new core holes.
6	Milestone M065. Issue report on the mechanical properties of lithophysal tuff.
7	Milestone M067. Issue report on the parametric sensitivity of laboratory mechanical properties of tuff.
8	Issue final report on the parametric sensitivity of fracture mechanical properties.
9	Milestone M609. Complete final report on demonstration breakout room testing.
10	Milestone M620. Complete final report on shaft convergence testing data.
11	Milestone M627. Complete report on sequential drift mining evaluation in the exploratory shaft facility (ESF).
12	Milestone N602. Complete final report on small-scale heater experiment results in ESF.
13	Milestone M631. Complete report on the results of the Yucca Mountain heated-block experiment in the ESF.
14	Milestone M691. Complete report on the results of the canister-scale heater experiments in the ESF.
15	Milestone N600. Summary report on the results of rockmass strength testing in the ESF.
16	Milestone M697. Complete report on the results of plate loading test in the ESF.
17	Issue final report on monitoring of mining methods in ESF drifts.
18	Issue final reports on monitoring of ground-support systems and drift stability.
19	Issue report on air quality and ventilation.

CONSULTATION DRAFT

8.3.1.15.2 Investigation: Studies to provide the required information for spatial distribution of ambient stress and thermal conditions

Technical basis for obtaining the information

Link to the technical data chapters and applicable support documents

The following sections of the SCP provide a summary of available data relevant to ambient stress and thermal conditions and identify areas of insufficient or inconclusive information:

<u>SCP section</u>	<u>Subject</u>
1.3.2.3	Existing stress regime
1.3.2.5	Geothermal regime
1.8.1	Summary of significant results (geology)
1.8.2	Relation to design (geology)
2.4.2	Thermal and thermomechanical properties of rock at the site (intact rock)
2.5.2	Thermal and thermomechanical properties of rock at the site (large scale)
2.6.1	Stress regime in region of the site
2.6.2	Stress regime at the site

Parameters

Table 8.3.1.15-1 summarizes the information and parameters required for resolution of design and performance assessment issues.

Purpose and objectives of the investigation

The performance allocation process as implemented by performance assessment and design has identified performance measures and goals. To determine whether the performance goals can be met, data must be available on various site parameters, and the data must have associated levels of confidence. The parameters and associated confidence levels are identified in the performance assessment and design issues and serve as the basis for planning of a site characterization program.

Table 8.3.1.15-1 provides a detailed comparison of the information required by performance assessment and design issues on ambient in situ stress and temperature conditions with the activities planned to acquire site characterization data on these conditions. Figure 8.3.1.15-1 shows the general link between site characterization and the issues requiring data, and

CONSULTATION DRAFT

Figure 8.3.1.15-3 depicts the detailed logic for completion of Investigation 8.3.1.15.2. Completion of the activities shown in Figure 8.3.1.15-3 and discussed in the following pages will provide all required information on ambient in situ stress and temperature conditions required by performance assessment and design.

Technical rationale for the investigation

The data requirements summarized in Table 8.3.1.15-1 are straightforward. For ambient stress conditions, determination of the principal stresses and the spatial variability thereof will provide the required information. For ambient thermal conditions, measurement of the in situ temperatures and the spatial variability thereof will satisfy the requirements. In addition, heat flow data may be used as a check on the internal consistency of models of heat and water flow at Yucca Mountain.

8.3.1.15.2.1 Study: Characterization of the site ambient stress conditions

The objective of this study is to characterize the ambient (pre-repository) state of stress of the Yucca Mountain host rock and surrounding units for use as initial conditions for geomechanical models used in the design and performance assessment of the repository underground facilities.

8.3.1.15.2.1.1 Activity: Anelastic strain recovery experiments in core holes

Objectives

The objective of these experiments is to determine the horizontal stresses at Yucca Mountain and especially the spatial variability thereof. In situ stress data will contribute to definition of initial and boundary conditions for mechanical and thermomechanical analyses.

Parameters

The parameters to be determined during these experiments are the minimum and maximum horizontal stresses. In addition, values of Young's modulus and Poisson's ratio will be obtained on the stress-determination samples to enable stresses to be calculated from measured strains.

Description

The anelastic strain recovery method of obtaining in situ stress data involves measurement of biaxial strains on core immediately after the core is removed from the core hole. Optimally, oriented core is used for the measurements. Elastic constants are used with the measured strains to calculate in situ stresses. The technique assumes that partial recoverable strain is proportional to the total recoverable strain, that the recovery behavior

CONSULTATION DRAFT

is linearly viscoelastic, and that the material is either isotropic or transversely isotropic. A comparison of the technique with hydraulic fracturing is presented in Teufel and Warpinski (1984).

This technique may be used in each new core hole at Yucca Mountain. Suitable core (i.e., unfractured and with limited lithophysae) will be measured, with the following experiment distribution in each hole:

<u>Thermal/mechanical unit</u>	<u>Number of experiments</u>
TCw	1 (if feasible)
PTn	1 (if feasible)
TSw1	2-3
TSw2	2-3
TSw3	0
CHn1v	1
CHn1z	1

The number and distribution of experiments are designed to examine both vertical and horizontal variability of in situ stress while minimizing the total number of experiments. After strains are measured on a specific interval, the core will be deformed in the laboratory to obtain Young's modulus and Poisson's ratio data with which to calculate the stresses from the measured strains.

The applicability of the technique to welded tuffs removed from relatively shallow depths (<500 m) will be evaluated by prototype testing in the Grouse Canyon Member in existing excavations in Rainier Mesa at the Nevada Test Site. The experimental program just outlined will be conducted only if the experiment results in the Grouse Canyon Member indicate that useful data are likely to be obtainable at Yucca Mountain.

Methods and technical procedures

The methods and technical procedures for Activity 8.3.1.15.2.1.1 are given in the following table.

Method	Technical procedure		Date
	Number	Title	
Anelastic strain recovery	TP-69	Procedure for determining in situ stress using anelastic strain recovery	TBD ^a

CONSULTATION DRAFT

Method	Technical procedure		Date
	Number	Title	
Laboratory deformation measurements	TP-74	Procedure for laboratory measurements in support of anelastic strain recovery	TBD

^aTBD = to be determined.

8.3.1.15.2.1.2 Activity: Overcore stress experiments in the exploratory shaft facility

Objectives

The primary objectives of these experiments are (1) to determine the in situ state of stress above, within, and below the repository host rock in that portion of the repository block penetrated by the exploratory shaft (ES), and (2) to evaluate the extent to which the ambient stress conditions are redistributed adjacent to excavations. In situ stress data will contribute to definition of initial and boundary conditions for mechanical and thermomechanical analyses.

Parameters

The parameters of this activity are in situ stresses and spatial variability thereof.

Description

Overcoring tests to measure stresses in two dimensions will be done at three levels in the ES in connection with the shaft convergence experiment (Activity 8.3.1.15.1.5.1). At each level, a 10-m-long EX-size pilot hole will be drilled downward from the center of the shaft. At least three overcore stress experiments using borehole deformation gages (BDG) will be conducted in each pilot hole; overcoring will produce 14.6-cm diameter hollow core. Strain measurements will be completed on the recovered core before biaxial stress testing in the laboratory. This testing will be conducted to obtain a deformation modulus with which to calculate stresses from the strain data observed in situ.

A separate set of overcoring experiments, to measure stresses in three dimensions, will be performed in lateral excavations from the ES. Holes will be drilled laterally both at the upper breakout level and at the main test level. Drillholes also will be located in a drilling alcove excavated laterally from the ES at the Calico Hills test level in the nonwelded and zeolitized tuffaceous beds of the Calico Hills (unit CHn1z). Three types of core holes will be included in these experiments. First, 76-mm-diameter

CONSULTATION DRAFT

(NX-size) holes will be cored to a depth of 15 m to examine fracture characteristics in the vicinity of the overcoring experiments. Then, 38-mm-diameter (EX-size) pilot holes will be cored beginning at or near the excavation boundary, and 15.2-cm-diameter core barrels will be used to overcore the pilot holes. Actual drillhole configurations and orientations may change, depending on local geologic conditions (fracturing, lithophysal content). At each location, overcoring will extend up to 15 m radially into the rock mass from the edge of the excavation.

Each core hole involved in the overcoring work will be surveyed for fractures by a borehole video camera. The fracture surveys are intended to provide data on the location, distribution, orientation, spacing, apertures, and infilling of the fractures at each location and to assist in placement of BDGs in the pilot holes. Borehole dilatometer experiments will be conducted in the 76-mm (NX) core holes to obtain estimates of the rock-mass deformation modulus and its variability along the length of each hole.

The number of locations at which overcoring will be performed at the main test level will depend on spatial variability.

Methods and technical procedures

The methods and technical procedures for Activity 8.3.1.15.2.1.2 are given in the following table.

Method	Technical procedure		Date
	Number	Title	
Borehole drilling coring	TBD ^a	NX, EX, and overcore hole drilling (horizontal)	TBD
	TP-1	Procedure for diamond drilling holes for instrumentation	TBD
	TP-2	Procedure for percussion drilling holes for instrumentation	TBD
Borehole video surveys	GP-10, RO		TBD
	TP-14	Procedure for inspection of boreholes using borescope	TBD
Borehole overcore deformation measurement	TBD	Overcore stress testing	TBD
	TP-3	TBD	TBD

CONSULTATION DRAFT

Method	Number	Technical procedure	
		Title	Date
Installation and use of borehole deformation gauges	TP-17	Procedure for installation and operation of borehole deformation gages	TBD
Laboratory biaxial stress testing	TP-4	TBD	TBD
Borehole dilatometer	TBD	Borehole dilatometer testing	TBD

^aTBD = to be determined.

8.3.1.15.2.2 Study: Characterization of the site ambient thermal conditions

The objective of this study is to characterize the ambient (pre-repository) temperature of the Yucca Mountain host rock and surrounding units for use as initial conditions for thermomechanical models used in the design and performance assessment of the repository underground facilities.

8.3.1.15.2.2.1 Activity: Surface-based evaluation of ambient thermal conditions

Objectives

The objectives of this activity are (1) to measure in existing wells the spatial variation of temperature with depth and to provide baseline temperatures within the repository host rock and surrounding units, (2) to measure thermal conductivity (near 25°C) of core samples as a check on independent thermal property determinations at various temperatures, and (3) to determine heat flow and its variation in the vicinity of Yucca Mountain.

Parameters

The parameters of this activity are ambient temperature and spatial variability thereof and thermal conductivity.

Description

Temperature logs will be obtained in all available wells at Yucca Mountain and in the surrounding area. Temperatures will be logged at 0.3-m

CONSULTATION DRAFT

depth intervals below the water table and in water-filled casing above the water table. In air-filled casing above the water table, temperatures will be measured at 30-m intervals because of long-time constants. In all instances, calibrated thermistor probes will be used. Temperature profiles and cross sections will be prepared.

Thermal conductivities will be measured on cores (in conjunction with Activity 8.3.1.15.1.1.3) or drill cuttings. In addition, least-squares analyses will be performed on nearly linear segments of temperature profiles and combined with the thermal conductivities to determine the near-surface heat flow and its variation, both vertically and laterally, within and around the proposed repository location.

Methods and technical procedures

The methods and technical procedures for Activity 8.3.1.15.2.2.1 are given in the following table.

Method	Technical procedure		
	Number	Title	Date
Borehole drilling and coring	TBD ^a	TBD	TBD
Drill-cutting and core sampling	TBD	TBD	TBD
Borehole ambient temperature measurement	GPP-02-R0	TBD	TBD
Laboratory thermal conductivity measurement	GPP-02, R0	TBD	TBD
	GPP-05, R0	TBD	TBD

^aTBD = to be determined.

8.3.1.15.2.3 Application of results

The parameters evaluated by the studies and activities of this investigation will be used for the following issues in the areas of performance assessment and repository design:

CONSULTATION DRAFT

HQ MARKUP/FDP-1

9-Dec-87/#77

<u>Issue</u>	<u>Subject</u>
1.6	Ground-water travel time (Section 8.3.5.12)
1.11	Configuration of underground facilities (Postclosure) (Section 8.3.2.2)
1.12	Seal characteristics (Section 8.3.3.2)
4.4	Preclosure design and technical feasibility (Section 8.3.2.5)

8.3.1.15.2.4 Schedule and milestones

This investigation addressing spatial distribution of ambient stress and thermal conditions, contains two studies: 8.3.1.15.2.1 (characterization of the site ambient stress conditions) and 8.3.1.15.2.2 (characterization of the site ambient thermal conditions). In the figure that follows, the schedule information for these studies is presented in the form of timelines. The timelines extend from implementation of the approved study plans to the issuance of the final products associated with the studies. Summary schedule and milestone information for this investigation can be found in Section 8.5.1.1. Additional schedule information involving exploratory shaft activities is given in Section 8.5.1.2.

Study 8.3.1.15.2.1 is partially constrained by the start of the exploratory shaft because some of the activities it contains will involve acquisition of data from the exploratory shaft. Study 8.3.1.15.2.2 is expected to begin within the first year of site characterization.

As part of this investigation, data will be acquired from field measurements at the surface and in the exploratory shaft facility (ESF). These data will be evaluated to determine the spatial variability of the ambient stress and thermal conditions of the site. Study 8.3.1.15.2.1 involves the possible surface-based measurement of strain recovery phenomena, which must be made in conjunction with drilling of coreholes. Also, as part of this study, stress measurements by the overcoring method will be made in the ESF. Study 8.3.1.15.2.2 will require data to be acquired from geophysical logging of existing and future drillholes as they become available in conjunction with other drilling and workover activities. The studies in this investigation are, therefore, constrained by the construction of the exploratory shaft, by the drilling of coreholes, and by the availability of geophysical logging data from existing and future drillholes.

The study numbers and titles corresponding to the timelines are shown on the left of the following figure. The points shown on the timelines represent major events or important milestones associated with the study. Solid lines represent study durations.

CONSULTATION DRAFT

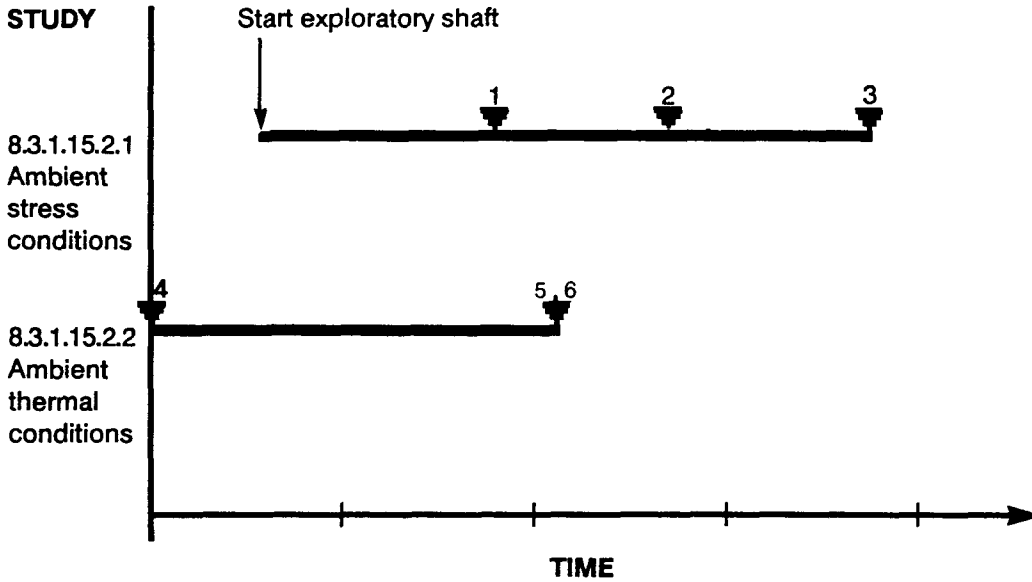

8311524

The points on the timeline are described in the following table:

<u>Point number</u>	<u>Description</u>
1	Begin stress measurement program in the exploratory shaft facility.
2	Milestone M687. Complete report on overcore stress experiments.
3	Issue summary report on the results of in situ stress studies in the site vicinity.
4	Begin surface-based acquisition of temperature data.
5	Milestone Z304. Issue report on the characterization of the site ambient thermal conditions.
6	Milestone Q062. Issue report on the thermal regime of the unsaturated zone.

Nuclear Waste Policy Act
(Section 113)

Section 8.3.1.16

Consultation Draft

PRECLOSURE HYDROLOGY



Site Characterization Plan

Yucca Mountain Site, Nevada Research and Development Area, Nevada

Volume V

January 1988

U.S. Department of Energy
Office of Civilian Radioactive Waste Management
Washington, DC 20585

CONSULTATION DRAFT

8.3.1.16 Overview of preclosure hydrology program: Description of preclosure hydrologic characteristics and conditions required by the performance and design issues

Summary of performance and design requirements for hydrology information

The preclosure hydrology test program addresses the requirements of performance and design issues. The hydrologic conditions, which include the potential for flooding, the availability of water for repository construction and operation, and the subsurface hydrologic conditions both within and above the repository horizon, must be examined to determine if engineering measures that require excessive cost, or technology beyond that which is reasonably available, will be needed.

The preclosure hydrology program (this section) and the geohydrology program (Section 8.3.1.2) will obtain specific data required for the design of the systems and components that are important to safety. The descriptions and analyses will consider the margins of safety under conditions that may result from expected operational occurrences, including those of natural origin such as flooding. These analyses must also consider the adequacy of structures provided for the prevention of accidents and mitigation of their consequences, including natural phenomena. Thus, information on the flash-flood potential of the site is needed to aid in the design of the flood control measures, should they be required.

Four issues (Issues 1.11, 1.12, 4.2, and 4.4) request data from the preclosure hydrology program. The requests for hydrologic data can be summarized as follows:

1. Information required for Issue 4.4 (technical feasibility, Section 8.3.2.5) and Issue 4.2 (nonradiological health and safety, Section 8.3.2.4) relates to the potential for surface flooding. Flood frequency and magnitude data are needed for analyses being performed to determine the impacts of potential flooding on the design of the surface facilities.
2. The second type of data requested by Issue 4.4 are the parameters required to locate adequate and alternative sources of water for the repository. Current plans are to develop two new wells for repository water supply. In the event of well failures, an alternative source of water also must be available. Existing wells J-12 and J-13 could be adequate for repository-related water needs and will be considered in the evaluation for suitable alternative sources. Characteristics of aquifers proximal to the site will be evaluated to identify potentially suitable sources. Modeling studies in support of Activity 8.3.1.2.3.3 will determine the possible changes to the flow system that might result from withdrawals made from the wells supplying water for the repository and from the proposed alternative sources.
3. Issues 4.4 (technical feasibility, Section 8.3.2.5), 1.11 (configuration of underground facilities, Section 8.3.2.2), and 1.12 (seal characteristics, Section 8.3.3.2) require a description of the hydrologic conditions within and above the repository horizon. This

CONSULTATION DRAFT

information is needed to estimate moisture content, flux, and potential moisture influx above and within the host horizon, as well as the potential for perched water zones, which will be used as input for the design of the repository, shaft liners, and seals.

Approach to satisfy performance and design requirements

The strategy of the preclosure hydrology program is to satisfy the requirements of design and performance issues. Three different types of preclosure hydrologic data have been identified by the design and performance issues: (1) flood frequency and magnitude, (2) water supply for repository-related water needs, and (3) subsurface hydrologic conditions at the site. These data requirements form the basis for the three investigations. Tables 8.3.1.16-1 and 8.3.1.16-2 list the parameters to be collected by this program, identify the issues that will use each parameter, and define the activities under which each parameter is to be collected. Figure 8.3.1.16-1 illustrates how the investigations of the preclosure hydrology program and the geohydrology program will obtain the data needed to satisfy the parameter requests of the design and performance issues.

The different types of data required will be obtained from three different investigations. Each investigation focuses on the specific type of data to be collected. Investigation 8.3.1.16.1 addresses the aspects of surface hydrology related to flood and debris hazards; Investigation 8.3.1.16.2 addresses the hydrologic and economic requirements of water supply; and Investigation 8.3.1.16.3 describes the subsurface conditions of the unsaturated zone that must be known to design the repository access ramps, underground facilities, shafts, shaft liners and seals. These data are required by the design issues to determine (1) the technical feasibility of constructing a repository in the unsaturated zone, (2) the compatibility of repository-related activities with the geohydrologic setting, and (3) the ability to construct the repository using available technology and at reasonable cost.

Interrelationships of preclosure hydrology investigations

Three investigations have been developed to provide the necessary information for the preclosure hydrology program. Investigation 8.3.1.16.1 (flood recurrence intervals) will obtain data that will be used to define flood recurrence intervals, flood levels, and the probable maximum flood at potential locations for the surface facilities.

Study 8.3.1.16.1.1 (flood potential of the Yucca Mountain site) will evaluate flood potential by collecting peak streamflow data, assessing the debris movement in drainages at or near the Yucca Mountain site, and investigating geologic evidence of paleofloods. The character of selected channel and floodplain deposits will be examined to determine the nature of the fluvial processes involved in deposition. Field judgments of the nature and severity of debris transport by floods will be made to evaluate the characteristics of debris hazards posed by the floods. Pertinent engineering analytical techniques, including standard flood-frequency analysis techniques, will be applied to the data collected in the appropriate drainages. This will yield an estimate of the magnitude and frequency of future flood events. These standard flood-frequency analysis techniques will be used to determine

Table 8.3 1.16-1. Data requirements of the design and performance issues satisfied by the preclosure hydrology program for System Element 1.1.1 (surface)

SCP Issue requesting parameters	Design parameters	Goal	Confidence	Characterization parameters	Testing basis			Studies/activities
					Current estimate	Present confidence ^a	Confidence needed ^b	
4.4 Technical feasibility (Section 8.3.2.5) 4.2 Nonradiological health and safety (Section 8.3.2.4)	Surface hydrology at all surface facility locations	Determine parameter values using ANSI and other standard applicable methods	High	Precipitation quantities and rates (from regional data)	Refer to Section 5.1	Low to moderate	High	Studies 8.3.1.16.1.1 (flood potential of Yucca Mountain), and
	Magnitude of 5, 25, 50, 100, 500 yr, and probable maximum floods	Define elevation of flood levels to ± 2 m		Streamflow rates, quantities, and durations (clear water)	Refer to Bullard (1986)	Low	High	8.3.1.2.1.1 (regional meteorology), and 8.3.1.2.1.2 (runoff and streamflow)
	Area and depth of inundation for facilities and access portals			Peak flood discharge for 5, 25, 50, 100, 500 yr, and probable maximum floods	Refer to Bullard (1986) and Squires and Young (1984)	Low to moderate	High	
				Channel morphology and surface topography	Refer to Squires and Young (1984) and Waddell et al (1984)	Low to moderate	Moderate	
	Flow velocities	Calculate maximum tractive force of channel flow and sheet flow in area of inundation	High	Quantity and character of debris moved during flooding	Refer to Costa (1983)	Very low	High	Studies 8.3.1.16.1.1 (flood potential of Yucca Mountain) and
	Debris load of flows			Define water to sediment ratio	Refer to Costa (1983)	Very low	High	8.3.1.2.1.2 (runoff and streamflow), and
			Characterize sediments within watershed	Refer to Costa (1983)	Very low	High	Investigation 8.3.1.2.2 (unsaturated zone hydrologic system)	

^aPresent confidence ratings of high, moderate, and low are based on the quality of data and the number of site specific measurements currently available
^bConfidence needed is an indication of the level of certainty that will be necessary to demonstrate that a goal is met

8.3.1.16-3

CONSULTATION DRAFT

Table 8.3.1.16-2. Data requirements of the design and performance issues satisfied by the preclosure hydrology program for System Element 1.1.2 (subsurface)

SCP Issue requesting parameters	Design parameters	Goal	Confidence	Characterization parameters	Testing basis			Studies/activities
					Current estimate	Present confidence ^a	Confidence needed ^b	
4.4 Technical feasibility (Section 8.3.2.5)	Sustained yield of wells	864,000 m ³ /yr	Moderate	Aquifer transmissivity and storage coefficient	To be determined from well testing	Medium	Moderate	Studies 8.3.1.16.2.1 (location of adequate water supply) and 8.3.1.2.1.3 (regional ground-water flow system)
1.11 Configuration of underground facilities (Section 8.3.2.2)	Water inflow to underground facility (including seasonal variation)	Quantify potential inflow rate (total into mine). Expected 0-20 gpm accuracy ± 10	Moderate	Fracture flow into ESF	≤ 100 gpd	Low	Moderate	Studies 8.3.1.2.2.3 (surface based exploratory shaft testing), 8.3.1.2.2.4 (unsaturated-zone percolation), and 8.3.1.16.1.1 (flood potential of Yucca Mountain)
1.12 Seal characteristics (Section 8.3.3.2)								

^aPresent confidence ratings of high, moderate, and low are based on the quality of data and the number of site-specific measurements currently available.

^bConfidence needed is an indication of the level of certainty that will be necessary to demonstrate that a goal has been met.

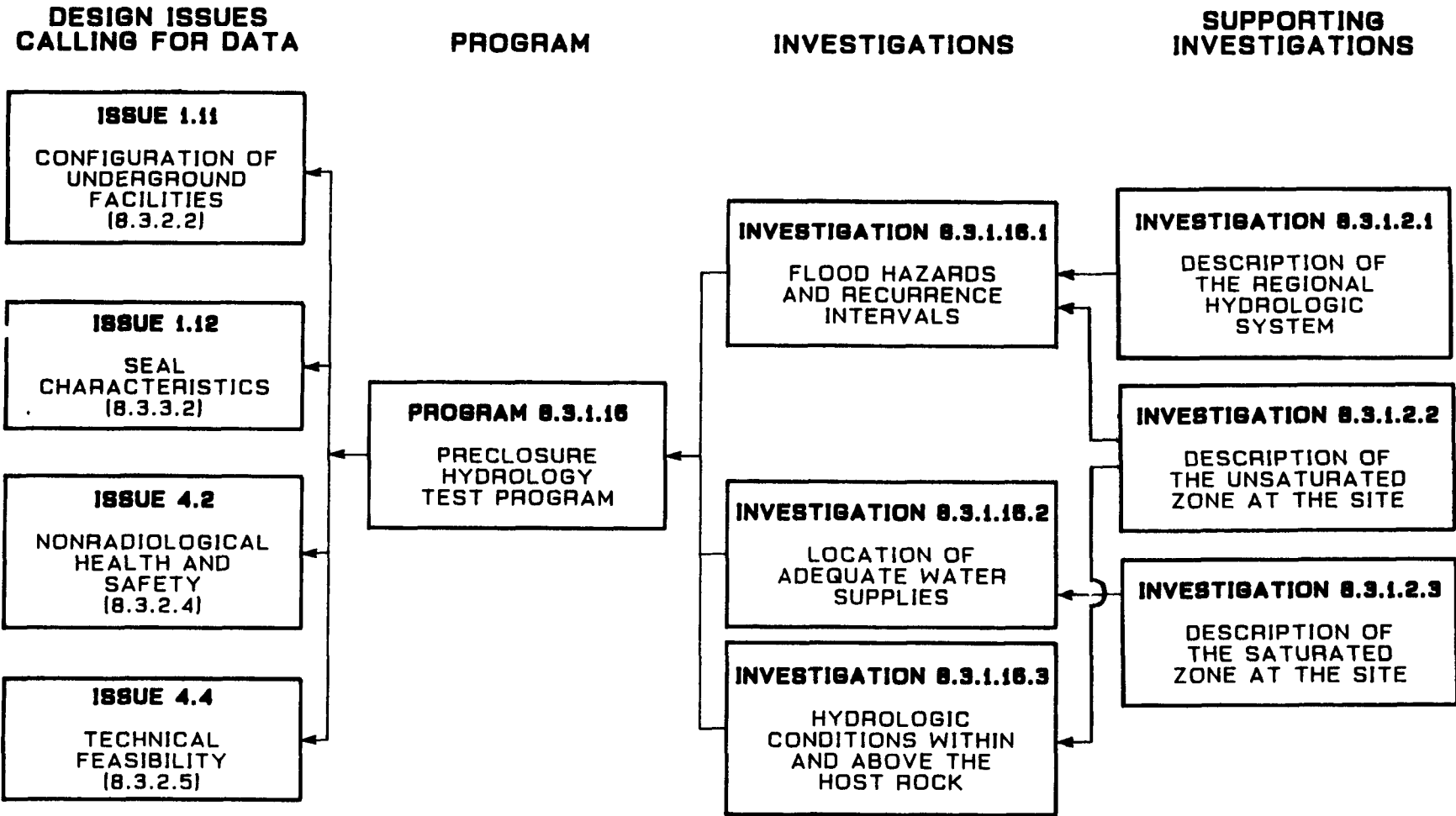

Figure 8.3.1.16-1. Relationship between the preclosure hydrology test program and its investigations.

CONSULTATION DRAFT

design requirements for nonsensitive structures while more conservative flood-hazard design requirements will be used for sensitive structures such as shafts and waste-handling structures.

The specific parameters that have been defined for Study 8.3.1.16.1.1 are the maximum rates and quantities of precipitation, streamflow characteristics, flood flow and debris transport conditions, and the recurrence for runoff and flood events. By calculating flood recurrence intervals, and quantifying the probable maximum flood level, adequate design measures can be implemented to avoid and mitigate the hazards associated with flood events.

Investigation 8.3.1.16.2 (adequate water supplies) addresses the location of adequate water supply for repository construction, operation, and closure. Two subordinate concerns to this investigation are the location of an alternative water supply and the possibility of using wells J-12 and J-13 as the alternative wells.

The second study, Study 8.3.1.16.2.1 (adequate water supply for the mined geologic disposal system) consists of three activities. The parameters that will be evaluated include the hydraulic characteristics of aquifers located proximal to the site, the cost and feasibility of constructing new water wells and a distribution system, and the identification of the possible effects on the flow system that might result from water withdrawals made from the proposed primary wells or from the proposed alternative wells.

Investigation 8.3.1.16.3 (ground-water conditions) involves characterizing the unsaturated zone above and within the repository horizon to define the moisture conditions between the repository and the land surface.

Study 8.3.1.16.3.1 is primarily a synthesis activity. The characterization of the hydrologic conditions within and above the repository horizon will be accomplished by studies being performed in support of Investigation 8.3.1.2.2. Although the bases for addressing the investigations are different (repository design versus long-term performance assessment), the parameters that must be obtained to satisfy both of these investigations are the same. Information on flux, moisture content, and potential influx will be obtained from the geohydrology program (Section 8.3.1.2). The data collected under the geohydrology program will be compiled, analysed, and evaluated under Activity 8.3.1.16.3.1.1, and will be used to define the moisture conditions at the site that are needed for design.

The schedule information provided for investigations in this section includes the sequencing, interrelationships, and relative durations of the studies in the investigation. Specific durations and start/finish dates for the studies are being developed as part of ongoing planning efforts and will be provided in the SCP at the time of issuance and revised as appropriate in subsequent semiannual progress reports.

CONSULTATION DRAFT

8.3.1.16.1 Investigation: Flood recurrence intervals and levels at potential locations of surface facilities

Technical basis for obtaining the information

Link to the technical data chapters and applicable support documents

Section 3.2 summarizes the current information regarding flood history, the potential for future flooding, current and future studies of flood and debris hazards, and flood protection. Local convective storms coupled with the rugged terrain at Yucca Mountain can cause intense flash flooding to occur sporadically in dry washes that drain the mountain. The meteorology and climatology of the Yucca Mountain site and the region are discussed further in Section 5.1. Further evaluation of the flood potential of these washes is necessary to ensure adequate design of the surface facilities. Flood protection design considerations are discussed in Sections 6.2.4 and 3.10.2.

Parameters

The following parameters will be measured or calculated as a result of the site studies planned to satisfy this investigation:

1. Precipitation quantities and rates.
2. Streamflow rates, quantities, and durations.
3. Peak flood discharges.
4. Quantity and character of debris moved during floods.
5. Character of fluids moved during flooding (relative proportions of water and sediment).
6. Recurrence intervals for runoff and flooding.

Most of the data for these parameters are being, or will be, collected through the following studies:

<u>Study</u>	<u>Subject</u>
8.3.1.2.1.2	Characterization of regional surface water (surface-water runoff and fluvial transport of debris by floods)
8.3.1.5.2.1	Characterization of the Quaternary regional hydrology (regional paleofloods)
8.3.1.12.2.1	Meteorological data collection at the Yucca Mountain site

Purpose and objectives of the investigation

To meet the purpose of identifying the potential hazards associated with floods and debris movement, three objectives must be met: (1) to determine the magnitudes and frequencies of major flood events that can potentially

occur during the period of repository operation, (2) to identify all potential areas of inundation, and (3) to determine the quantities and size characteristics of debris transported by flooding. Figure 8.3.1.16-2 illustrates how the activities of Study 8.3.1.16.1.1, in conjunction with activities of the geohydrology program, will obtain the required parameters.

Technical rationale for the investigation

Surface facilities such as roadways, building pads, and buildings to serve as workshops, offices, laboratories, and living spaces, must be located and designed for minimum natural disturbance during their intended life (approximately 100 yr) largely for safety and economic reasons. It is also critical that all surface sites for handling the waste packages, including buildings, storage areas, and repository access facilities such as shaft collar and hoisting structures, be located in an area where flood or debris-flow events would not have serious effects on their stability during the preclosure period. To accomplish this, flood and debris-hazard studies have been designed to document flooding and severe sediment erosion, transport, and deposition to aid in predicting the maximum flood intensities and recurrence intervals, which are necessary for the design of safe facilities.

In these studies, floods will be characterized by measuring the peak streamflows and generally assessing associated debris movement in drainages that are at or near the Yucca Mountain site. The surficial character of selected channel and floodplain deposits in the numerous ephemeral drainages will also be examined in an attempt to determine the nature of the fluvial processes involved in the emplacement of the deposits. Field judgments of the nature and severity of debris transport by floods will be made to evaluate properly the characteristics of debris hazards posed by the floods. Pertinent engineering-analytical techniques, including standard-flood-frequency-analysis techniques (e.g., the log-Pearson type III distribution), will be applied to the data collected in the drainages in question to estimate the magnitude and frequency of future floods. Using this approach, non-sensitive structures can then be designed by standard engineering methods of flood analysis, while the shaft and restricted-area facilities will use more conservative flood hazard design procedures.

Peak streamflow data at and around Yucca Mountain will be collected as part of Activity 8.3.1.2.1.2.1 (surface-water runoff monitoring). The analyses of these data will also incorporate data from nearby crest-stage gages that have been operative since the 1960s as part of the U.S. Geological Survey, Nevada Department of Transportation flood-study program. The field judgments of the nature and severity of debris transport by flood flows will be made as part of Activity 8.3.1.2.1.2.2 (transport of debris by severe runoff). Pertinent information from Activity 8.3.1.5.2.1.1 (regional paleoflood evaluation) will also be transferred to this activity for use in characterizing the flood and debris hazards.

The techniques used to obtain this information will complement each other and also will allow a comparison of data to decrease data uncertainty. It is recognized that the short period of record for direct flow measurements

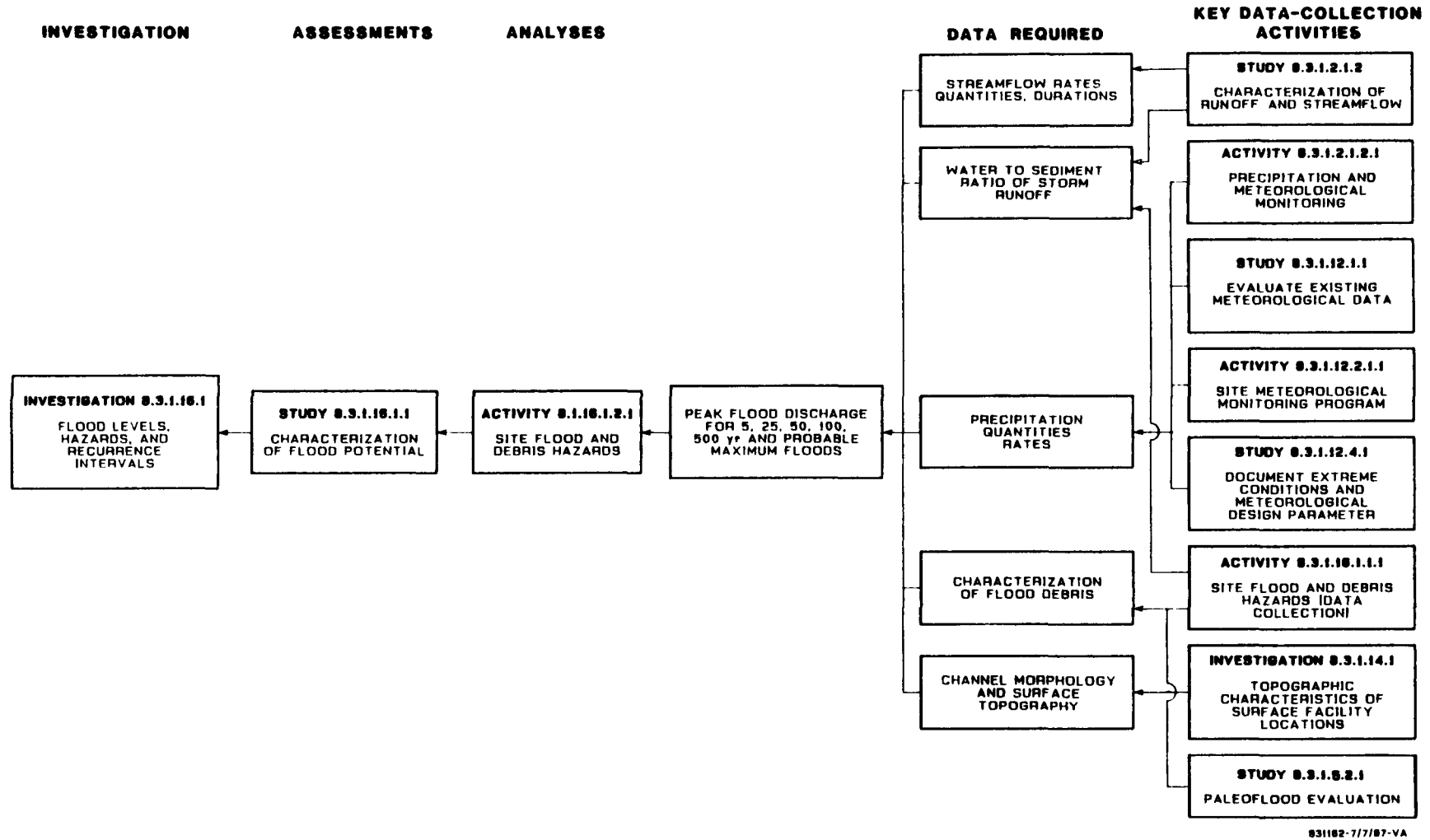

Figure 8.3.1.16-2. Logic diagram for Investigation 8.3.1.16.1 (flood recurrence intervals).

CONSULTATION DRAFT

will be inadequate to derive confident estimates of flood recurrence intervals larger than a few years. Therefore, this study will rely upon a combination of direct and indirect techniques. In areas where the flood recurrence and intensity analyses will have to be translated to surface facility sites where actual data may not have been collected, the geologic record of paleofloods will be used to temper the probability analyses for sensitive surface facilities. Trench studies of ancient deposits and morphologic studies of the area will be used to complement the peak streamflow measurements for determining the characteristic depths of flooding, depths of scour, characteristics of sediment load, and thickness of deposits formed in the past.

Section 8.3.1.5.2 describes paleoflood studies that will be used to augment this investigation. Initial trench studies suggest that paleoflood techniques may not be adequate to fully assess flood and debris hazards because of the lack of datable materials (e.g., organics, tephra, and soil formation). Thus, a dual strategy will be maintained to determine flood and debris hazards. Crest-stage data collection will continue indefinitely, and flood events will be documented if and when they occur. Data from these modern flood studies will be supplemented by information from paleoflood reconstruction activities to be performed as part of the geohydrology program (Section 8.3.1.2).

8.3.1.16.1.1 Study: Characterization of flood potential of the Yucca Mountain site

This study contains one activity and evaluates the potential for flooding in the many small, dry, desert washes that drain Yucca Mountain. This evaluation will be used for designing the surface facilities for the proposed repository. Proper design for flood potential is necessary to ensure the safety of the workers and the surface facilities.

8.3.1.16.1.1.1 Activity: Site flood and debris hazards studies

Objectives

The objective of this activity is to assess the flood and debris hazards at and near the potential repository surface facilities locations to allow adequate design of facilities to prevent or reduce hazards to an acceptable level.

Parameters

The parameters of this activity are

1. Precipitation quantities and rates.
2. Streamflow rates, quantities, and durations.
3. Peak flood discharge.

CONSULTATION DRAFT

4. Quantity and character of debris moved during severe floods.
5. Character of fluids moved during flooding (relative proportions of water and sediment).
6. Recurrence intervals for runoff and flooding.
7. Channel morphology definition.
8. Surface topography.

Description

Floods will be characterized by measuring the peak streamflows and assessing the debris movement in drainages that are at or near the Yucca Mountain site. Some streamflow measurement will be made as part of Activity 8.3.1.2.1.2.1 (regional surface water runoff studies), but most measurement will be part of surface runoff monitoring at Yucca Mountain, Activity 8.3.1.2.2.1.2 of Investigation 8.3.1.2.2 (unsaturated-zone hydrologic system). These activities will use many stream gages, rain gages, and some automated fluvial-sediment samplers situated at strategic locations. Streamflow documented by the stream gage networks of these two activities will be incorporated into the pertinent flood-prediction analyses. Twenty-five to fifty small drainages may be included in this study effort. Pertinent flood data from drainages throughout the southern Nevada region will be incorporated into analyses of flooding at and around Yucca Mountain.

The surface character of selected channel and floodplain deposits in the numerous ephemeral drainages in and around the proposed storage site will be examined to determine the fluvial processes involved in the emplacement of the deposits. If this reconnaissance discloses a variety of processes or significant variations within any process, an attempt will be made to differentiate the processes and degrees of differences. The results of this effort may then determine whether the variations in the characteristics of the deposits can or should be shown on surficial deposit maps of the drainages.

Field judgments of the nature and severity of debris transport by flood flows will be made to evaluate properly the characteristics of debris hazards from flood flows. No standard techniques are available to sample moving coarse-grained debris, which constitutes the major debris hazard, but flood investigators will describe both qualitatively and somewhat quantitatively (by careful field observations) the character of debris that has moved within and through the drainage during severe runoff events. Also, some debris movement characteristics will be deduced through analysis of the debris deposits. Fresh erosion that has resulted from recent flooding will be noted on maps to allow an assessment of potential slope instability. Assembling this type of semiquantitative information will, with time and experience, form the bases for designating the degrees of debris hazards on different types of slopes. Much of the debris hazard assessment is experimental at this time, and more precise investigative plans cannot be formalized until experience with debris movement during flooding increases.

CONSULTATION DRAFT

Pertinent engineering analytical techniques, including standard-flood-frequency-analysis techniques, will be applied to the data collected in the drainages in question to estimate future flood flows. Several computational or graphic techniques are available to estimate probable peak flood flows.

In one graphic technique, a maximum envelope curve defines the largest floods measured for variously sized drainage basins (Crippen and Bue, 1977). Thus, for a given size of drainage, the curve predicts the largest flood that would be expected on the basis of historical evidence of the largest observed floods for drainages of comparable size within the same geographic region.

Another widely used technique in the nuclear industry is the computational determination of the probable maximum flood (PMF) (ANSI/ANS 2.8-1981). This computational procedure is based on the U.S. National Weather Service estimates of probable maximum precipitation that can be expected throughout a specific geographical area. Neither of these techniques takes into account debris transport that may pose a serious hazard associated with a flood.

A computational technique based on field evidence has been proposed (Costa, 1983). In this technique, the average size of the five largest boulders deposited in the channel by fluid flows is determined. A velocity capable of moving particles of that size is computed, and physical surveys of the stream channel in the reach of the deposits are used to help assess the area of the flow section. Then the product of the velocity and the flow-sectional area determines the discharge necessary to move the largest particles. Application of the technique thus yields an estimate of the peak flood discharge that emplaced the largest debris fragments.

Flood frequencies and recurrence intervals may be evaluated with the log-Pearson type III curve. The log-Pearson type III is a theoretical, flexible frequency distribution computed by calculating the mean, standard deviation, and skewness coefficient of the logs of peak annual discharge data. A frequency factor is obtained from tables of skewness coefficients and exceedance probabilities. Regional values of the skewness coefficients are available.

Other similar techniques, if available, will also be applied to the drainages of concern. Flow predictions resulting from these applied techniques can then be compared, and a prediction of peak flood flows can result from the comparisons.

CONSULTATION DRAFT

Methods and technical procedures

The methods and technical procedures for Activity 8.3.1.16.1.1.1 are given in the following table.

Method	Technical procedure		Date
	Number	Title	
Streamflow measurement	HP-41, RO HP-42, RO HP-43, RO HP-44, RO HP-45, RO HP-46, RO	TBD ^a	TBD
Empirical engineering techniques for predicting flood discharge	Needed	TBD	TBD
Techniques for differentiating fluvial deposits on the basis of their surficial characteristics	Needed	TBD	TBD
Techniques for mapping surficially exposed fluvial deposits	Needed	TBD	TBD

^aTBD = to be determined.

8.3.1.16.1.2 Application of results

The information derived from the studies and activities of the plans described previously will be used in the following areas of site characterization, repository design, and performance assessment:

<u>Investigation or information need</u>	<u>Subject</u>
8.3.1.2.1	Regional hydrologic system
8.3.1.6.1	Present locations and rates of surface erosion
8.3.1.9.1	Degradation of markers
4.4.1	Site and performance assessment information needed for design (Section 8.3.2.5.1)

CONSULTATION DRAFT

Investigation or information need

Subject

- | | |
|-------|--|
| 4.4.7 | Design analyses including potential impacts of hydro-logic characteristics on design (Section 8.3.2.5.7) |
| 4.4.8 | Technology for surface facilities (Section 8.3.2.5.8) |

8.3.1.16.1.3 Schedule and milestones

The schedule and milestone information for this investigation is given in Section 8.3.1.16.3.3, at the end of Investigation 8.3.1.16.3 (ground-water conditions within and above the potential host rock).

8.3.1.16.2 Investigation: Location of adequate water supplies

Technical basis for obtaining the information

Link to the technical data chapters and applicable support documents

Section 3.8 summarizes the current information regarding the estimated quantity of water needed to support a mined geologic disposal system at Yucca Mountain.

Parameters

Three sets of parameters will be measured or calculated as a result of the site studies planned to obtain the information needed as follows:

1. Cost and feasibility of using wells J-12 and J-13 for repository-related water use as an alternative source.
2. Identification of a primary source of water for repository-related water needs.
3. Identification of an alternative source of water for repository-related water needs.
4. Identification and evaluation of potential effects of repository-related water withdrawals on the local flow system and water supply.

Purpose and objectives of the investigation

To meet the purpose of identifying the most suitable water supply and alternative, the following objectives must be met: (1) determine the adequacy of existing wells J-12 and J-13 in terms of available resource potential, total cost, and technologic feasibility as an alternative water supply for a repository at Yucca Mountain (water rights are discussed in Section 8.3.1.11), (2) identify and locate a primary source of water for a repository at Yucca Mountain, (3) identify and locate potential alternative sources of

CONSULTATION DRAFT

water, and (4) determine the potential effects of repository-related water withdrawals on the local flow system at Yucca Mountain. Figure 8.3.1.16-3 illustrates how the activities of Study 8.3.1.16.2.1 will obtain the parameters needed to satisfy the design requirements.

Technical rationale for the investigation

Current plans are to develop a primary source closer to the proposed site than wells J-12 or J-13 to supply repository-related water needs. In the event that a primary source cannot serve repository-related water needs through decommissioning, an alternative source of water must be readily available. Wells J-12 and J-13 (Figure 8.3.1.16-4) are under consideration as sources to provide water during repository site preparation and the early phases of construction if Yucca Mountain is selected. They are also being considered as possible alternative sources. The hydrostratigraphic unit source for wells J-12 and J-13, the Topopah Spring Member of the Paintbrush Tuff, is presently considered capable of yielding water at a sufficient rate to supply repository-related water needs through closure and decommissioning. An assessment of the expected future performance, estimated total cost, and the feasibility of using these wells as alternative sources is needed to demonstrate that the wells are adequate and can be used at a reasonable cost with available technology.

The water that will be used to support repository construction, operation, and closure will cause an increase in local water use, which could affect the local flow system at Yucca Mountain. Potential effects from repository-related water withdrawals will be identified and assessed to determine if any mitigating measures might be required.

The data required to satisfy the performance and design requirements will be collected by the four activities of Investigation 8.3.1.16.2 and other studies performed in support of Investigations 8.3.1.2.1, 8.3.1.2.3, and 8.3.1.9.2.

8.3.1.16.2.1 Study: Location of adequate water supply for construction, operation, closure, and decommissioning of a mined geologic disposal system at Yucca Mountain, Nevada

This study includes four activities.

8.3.1.16.2.1.1 Activity: Assessment of the cost, feasibility, and adequacy of wells J-12 and J-13 for use as the alternative water supply for a mined geologic disposal system at Yucca Mountain, Nevada

Objectives

The objective of this activity is to determine (1) the adequacy of wells J-12 and J-13 in terms of available resource potential and (2) the total cost

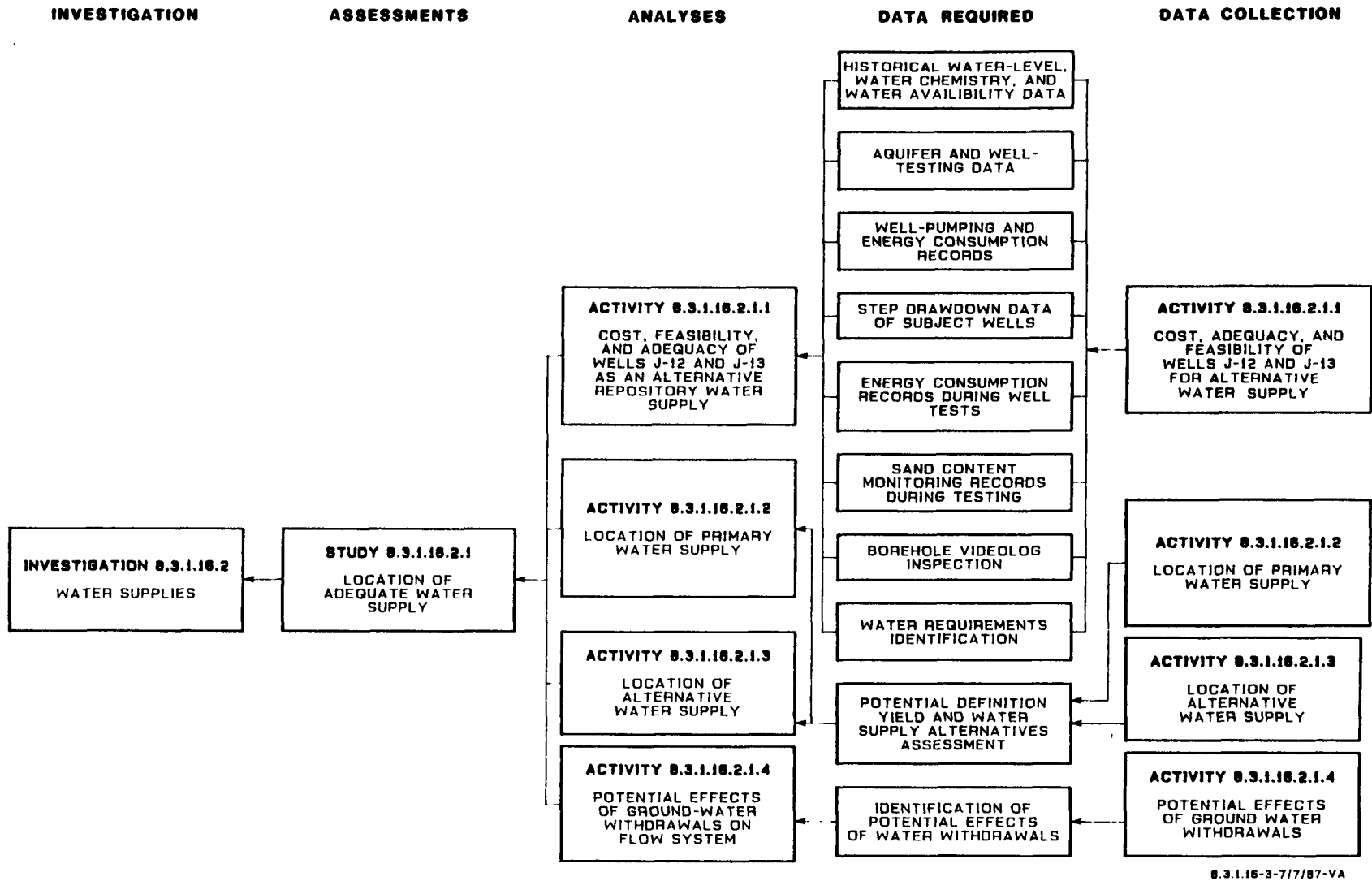
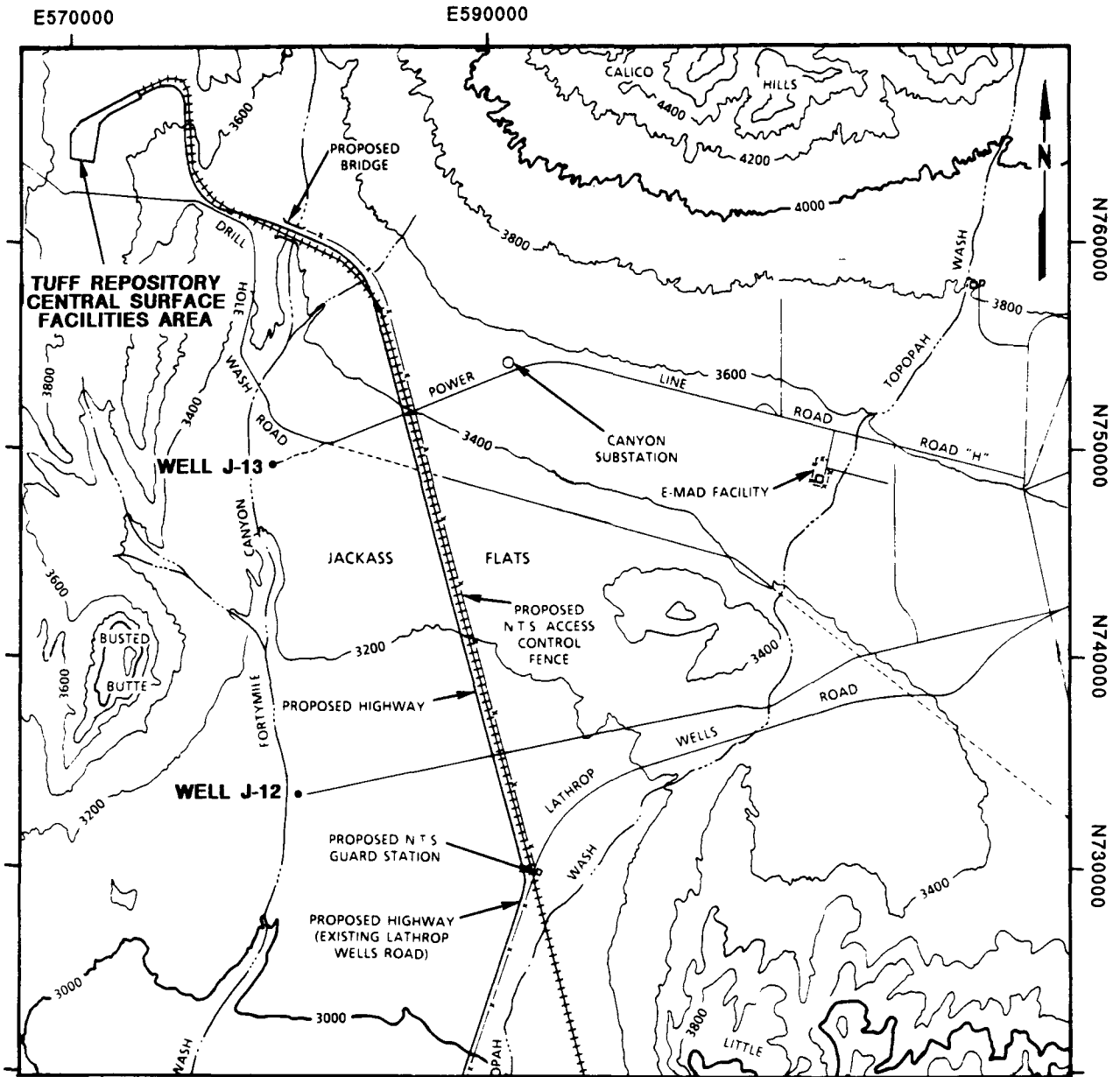

Figure 8.3.1.16-3. Logic diagram for Investigation 8.3.1.16.2 (water supplies).

CONSULTATION DRAFT



0 5000 FEET
0 1000 METERS

CONTOUR INTERVAL 200 FT

NTS - NEVADA TEST SITE

Figure 8.3.1.16-4. Locations of wells J-12 and J-13 relative to the surface facility location.

CONSULTATION DRAFT

and technical feasibility of supplying the water needed to support a repository at Yucca Mountain. These wells will be evaluated for use as alternative sources.

Parameters

The parameters required for this activity are the total time-phased water demand through decommissioning, estimated peak annual water demand, the maximum water resources available from wells J-12 and J-13 based on historical production capabilities and existing well and pumping-test data, the estimated cost of water withdrawals (pumping, treatment, and distribution), and the quantity of water appropriated by local water users through permits and certifications.

Description

Several steps may be necessary to complete this activity. The actual field work performed will depend on the type, quality, and amount of data available. Thus, the first step will be to compile all data pertinent to the construction, operation, and performance of wells J-12 and J-13. These data will be analyzed to determine their adequacy for predicting long-term well performance. The data to be compiled include historical water levels, water chemistries, aquifer test results, well test results, energy consumption records, and well construction records.

After all existing data have been compiled, the following methods will be applied. Hydrographs of water levels, ionic constituents, and pumping rates will be prepared to evaluate the past performance of the subject wells. Aquifer and other test results will be reanalyzed as necessary to meet the quality assurance requirements of the NNWSI Project. If the existing data are found inadequate for use in assessing long-term well performance, a well test plan will be developed.

The well test plan will identify any additional tests and analyses that may be necessary to assess long-term well performance. Specific tests could include step drawdown testing of both wells, sand content monitoring during testing (if applicable), borehole videolog inspection of the casing and screens, and water chemistry analyses. Step drawdown test results will be analyzed to determine well- and formation-loss coefficients, optimal and maximum well yields, and operating efficiencies. Energy consumption will be monitored during testing to aid in developing unit costs for ground-water withdrawals. Pumping of sediment will be measured and the physical condition of the wells will be described to ascertain whether the wells will require excessive maintenance during long-term operation.

The final calculated repository water requirement will be obtained from the Advanced Conceptual Design report and will be used as the baseline to assess the adequacy and viability of wells J-12 and J-13 for use as an alternate water supply. All results will be compiled and evaluated to determine the cost and technical feasibility of meeting the repository water demand.

CONSULTATION DRAFT

Methods and technical procedures

The specific methods and technical procedures for this activity are to be determined.

8.3.1.16.2.1.2 Activity: Location of a primary water supply for a mined geologic disposal system at Yucca Mountain, Nevada

Objectives

The objective of this activity is to identify and locate a primary source of water for a repository at Yucca Mountain. Ideally, the primary sources would be located nearer to the surface facilities than wells J-12 and J-13, and at an elevation above the surface facilities, thereby reducing distribution costs and total pumping lifts.

Parameters

This activity will rely heavily on input from Investigations 8.3.1.2.1 and 8.3.1.2.3. Values of aquifer storativity, transmissivity, thickness, and depth to water will be provided by the hydrologic drilling and modeling activities. Remote sensing information (i.e., satellite imagery) will be used in performing lineament analyses to help identify potentially suitable well locations. The parameters that will be measured or calculated as a result of this activity are the locations of, distances to, and relative elevations of all potentially suitable aquifers.

Other parameters that will be obtained from this activity and Study 8.3.1.9.2.2 (ground-water resource assessment) include a compilation of local water users, water uses, amounts of existing local appropriations, points of diversion, and points of use.

Description

The first part of this activity will focus on identifying the amount of unappropriated water available from sources other than wells J-12 and J-13. Other sources may include other water wells located on the NTS, or other unappropriated ground water in basins adjacent to the site. These data, in conjunction with imagery analysis techniques described by Taranik and Trautwein (1978), will be used to define the ground-water yield potential of areas located proximal to the Yucca Mountain site. Subsequent to defining the ground-water yield potential, options for a primary water source will be identified. Once the location of the potential primary source has been identified, a test well will be developed and tested. The hydraulic characteristics of the well will be determined to ensure that the source is capable of producing adequate water to meet the repository-related water demand.

Methods and technical procedures

The methods and technical procedures for this activity are to be determined.

CONSULTATION DRAFT

8.3.1.16.2.1.3 Activity: Location of alternative water supplies for a mined geologic disposal system at Yucca Mountain Nevada.

Objective

The objective of this activity is to identify and locate an alternative source of water for a repository at Yucca Mountain in the event that the primary source cannot meet the water demand.

Parameters

As with Activity 8.3.1.16.2.1.2, this activity will rely heavily on input from Investigations 8.3.1.2.1, 8.3.1.2.3, and 8.3.1.9.2. Values of aquifer storativity, transmissivity, thickness, and depth to water will be provided by the hydrologic drilling and modeling activities. Remote sensing information will be used in performing lineament analyses to help identify potentially suitable well locations. The parameters that will be measured or calculated as a result of this activity are the locations of, distances to, and relative elevations of all potentially suitable aquifers.

Other parameters that will be obtained from this activity and Study 8.3.1.9.2.2 (water resource assessment) include a compilation of local water users, water uses, amounts of existing local appropriations, points of diversion, and points of use.

Description

The first part of this activity will focus on identifying the amount of unappropriated water available from potential alternative sources. These sources may include other water wells located on the NTS or other unappropriated ground water in basins adjacent to the site. These data, in conjunction with imagery analysis techniques described by Taranik and Trautwein (1978) will be used to define the ground-water yield potential of areas located proximal to the Yucca Mountain site. Subsequent to defining the ground-water yield potential, options for alternative water sources will be identified. A potential well location will be identified, and a test well will be drilled and tested.

Methods and technical procedures

The methods and technical procedures for this activity are to be determined.

8.3.1.16.2.1.4 Activity: Identification and evaluation of potential effects of repository related withdrawals on the local flow system at Yucca Mountain, Nevada

Objectives

The objective of this activity is to determine the potential effects of repository-related water withdrawals on the local flow system at Yucca Mountain. The potential effects from water withdrawal include modifications

CONSULTATION DRAFT

to the preclosure ground-water travel path and the lowering of the potentiometric surface. Such effects will be identified and quantified to establish any mitigating measures that might be required.

Parameters

The parameters that will be collected from this activity are the effects of the time-phased water withdrawals from the primary and alternative water supply wells on the local flow system.

Description

Using the parameters and computer codes from Investigations 8.3.1.2.1 and 8.3.1.2.3, the effects of the time-phased water withdrawals on the local flow system will be modeled. The results of these computer simulations will be evaluated, and any effects on the flow system will be identified. If any adverse effects on the flow path or potentiometric surface are identified, plans to mitigate the effects will be developed. It is quite likely that any effect on the potentiometric surface may be beneficial to waste isolation, as the thickness of the unsaturated zone will increase in areas where drawdown is induced due to pumping. This will be assessed and documented for further evaluation of repository performance.

Methods and technical procedures

The methods and technical procedures for this activity are to be determined.

8.3.1.16.2.2 Application of results

The information obtained from Study 8.3.1.16.2.1 will be used to assess the suitability of candidate wells for repository water supply through decommissioning. This information will be used as an input parameter to Information Need 1.11.4 (Section 8.3.2.2.4), which examines the design constraints to limit water usage for the repository. The results of this study will also be used as input to Information Need 4.4.3 (Section 8.3.2.5.3), which is the plan for repository construction, operation, closure, and decommissioning.

8.3.1.16.2.3 Schedule and milestones

The schedule and milestone information for this investigation is given in Section 8.3.1.16.3.3, at the end of Investigation 8.3.1.16.3 (ground-water conditions within and above the potential host rock).

CONSULTATION DRAFT

8.3.1.16.3 Investigation: Ground-water conditions within and above the potential host rock

Technical basis for obtaining the information

Link to the technical data chapters and applicable support documents

The following sections of Chapter 3 provide a technical summary of existing data relevant to this investigation:

<u>Section</u>	<u>Title</u>
3.9.1.3	Hydrochemistry
3.9.2.1	Hydraulic characteristics of the unsaturated zone
3.9.3.2	Potentiometric levels and head relationships in the unsaturated zone

Parameters

The following parameters will be measured or calculated as a result of the planned site studies:

1. Subsurface moisture content above the repository horizon.
2. Flux above and within the repository horizon.
3. Moisture content of the repository horizon.
4. Locations and descriptions of perched water zones.
5. Potential influx to the repository and access shafts.

Purpose and objectives of the investigation

To meet the purpose of describing the baseline characteristics of the unsaturated zone within and above the repository horizon, the following objectives must be met: (1) determine the amount of water inflow to the repository horizon including seasonal variations in inflow rate, (2) determine the existence of perched water, and (3) define the locations, depths, thickness, lateral extent, seasonal variation, and degree of saturation of perched water zones if any are identified. These data will be obtained from the geohydrology program (8.3.1.2); the preclosure hydrology program will synthesize the data to help resolve the design issues. Figure 8.3.1.16-5 illustrates the strategy that will be used to obtain and compile the required parameters for the design issues.

Technical rationale for the investigation

Measurements of the subsurface hydrologic conditions both above and within the repository horizon are required for design of the repository shafts, and seals. Preliminary data presented in Chapter 3 indicate that no special technology will be needed to construct and operate a repository at Yucca Mountain as a result of existing hydrologic conditions. Data obtained from this investigation will provide the design bases required to construct and operate a repository.

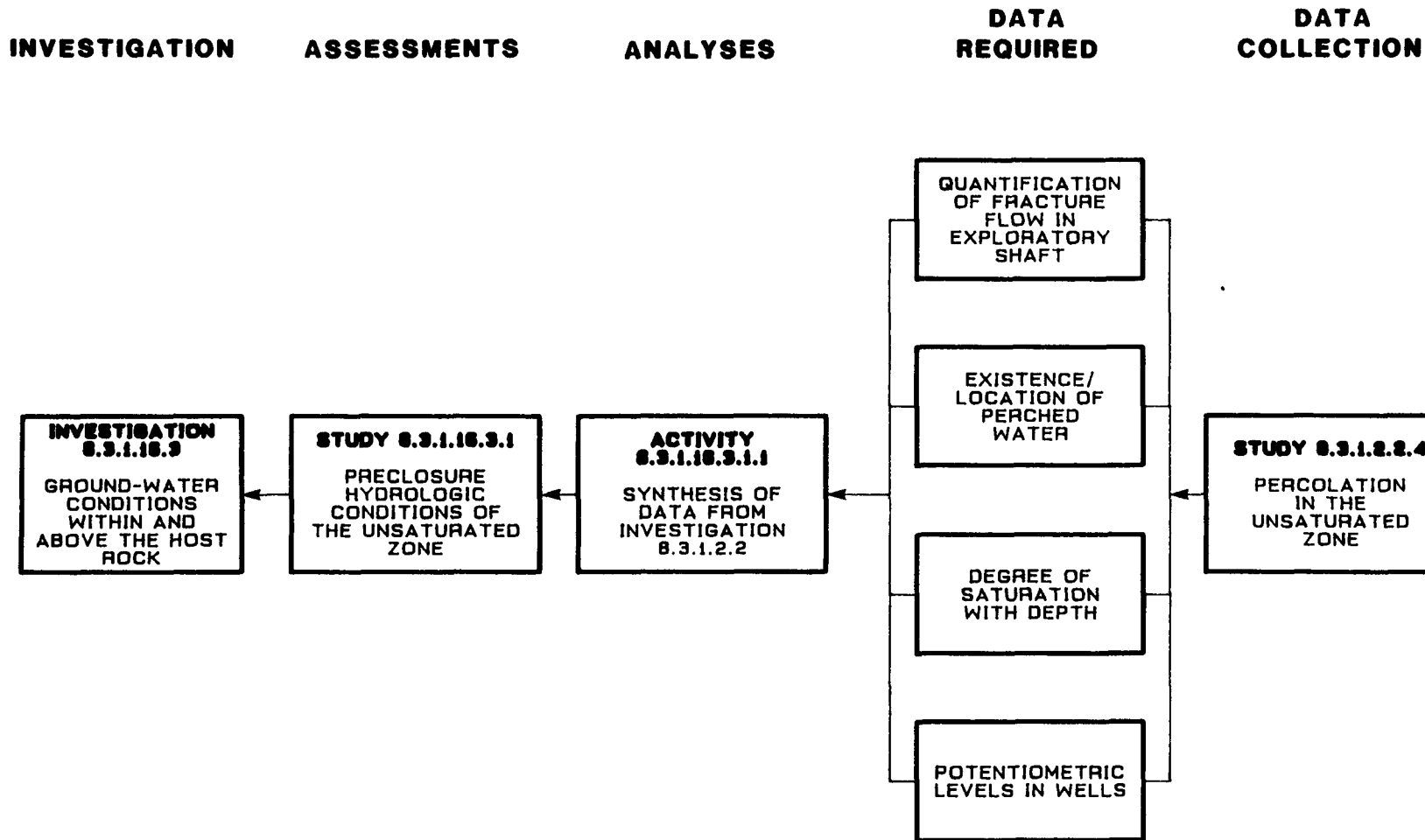

8.3.1.16-5-7/7/87-VA

Figure 8.3.1.16-5. Logic diagram for Investigation 8 3 1 16 3 (ground water conditions).

CONSULTATION DRAFT

8.3.1.16.3.1 Study: Determination of the preclosure hydrologic conditions of the unsaturated zone at Yucca Mountain, Nevada

This study includes one activity.

8.3.1.16.3.1.1 Activity: Synthesis of data from site program 8.3.1.2 to determine the preclosure hydrologic characteristics of the unsaturated zone at Yucca Mountain, Nevada

Objectives

The objectives of this activity are to compile the data collected under geohydrology Investigation 8.3.1.2.2, in Study 8.3.1.2.2.4 (exploratory shaft facilities investigations) for input to design Issue 4.4 (Section 8.3.2.5).

Parameters

The parameters that will be collected from Investigation 8.3.1.2.2 are flux, moisture content above and within the repository horizon, and locations and descriptions of perched water zones.

Description

The parameters obtained from Study 8.3.1.2.2.4 will be compiled and evaluated to ensure that data collected from the exploratory shaft is sufficient to satisfy the objectives set by the design issues. The information will then be passed to the design issues to be used as input.

Methods and technical procedures

There are no methods and technical procedures for this activity.

8.3.1.16.3.2 Application of results

The data collected by this investigation will serve as input parameters for design of the repository, access shafts, and seals. The following information needs call for data from this investigation:

<u>Information need</u>	<u>Short title</u>	<u>SCP section</u>
4.4.4	Repository design requirements	8.3.2.5.4
4.4.7	Design analyses (hydrologic impacts)	8.3.2.5.7
4.4.9	Technology for underground facilities	8.3.2.5.9

CONSULTATION DRAFT

8.3.1.16.3.3 Schedule and milestones

The preclosure hydrology program consists of three investigations, each of which contains one study: 8.3.1.16.1.1 (characterization of flood potential of the Yucca Mountain site), 8.3.1.16.2.1 (location of an adequate water supply), and 8.3.1.16.3.1 (determination of the preclosure hydrologic conditions at Yucca Mountain, Nevada). In the figure that follows, the schedule information for these studies is presented in the form of timelines. The timelines extend from the implementation of the approved study plans to the issuance of the final products associated with the studies. Summary schedule and milestone information for these studies can be found in Section 8.5.1.1.

Studies 8.3.1.16.1.1 and 8.3.1.16.2.1 in this program are ongoing. The experimental and modeling work for this entire program will proceed in parallel with characterization, design, and performance activities, and will interact with them in an iterative fashion.

The completion of investigations in this program is constrained by needs for information from other characterization programs. Completion of the milestone reports will require information from Sections 8.3.1.2 (geo-hydrology program), 8.3.1.5 (climate program), 8.3.1.9 (human interference program), 8.3.1.12 (meteorology program), and 8.3.1.14 (surface characteristics program).

The study numbers and titles corresponding to the timelines are shown to the left on the following figure. The points shown on the timelines represent major events or important milestones associated with the studies. Solid lines represent study durations, and dashed lines show interfaces. The data input or output at the interfaces are shown by circles.

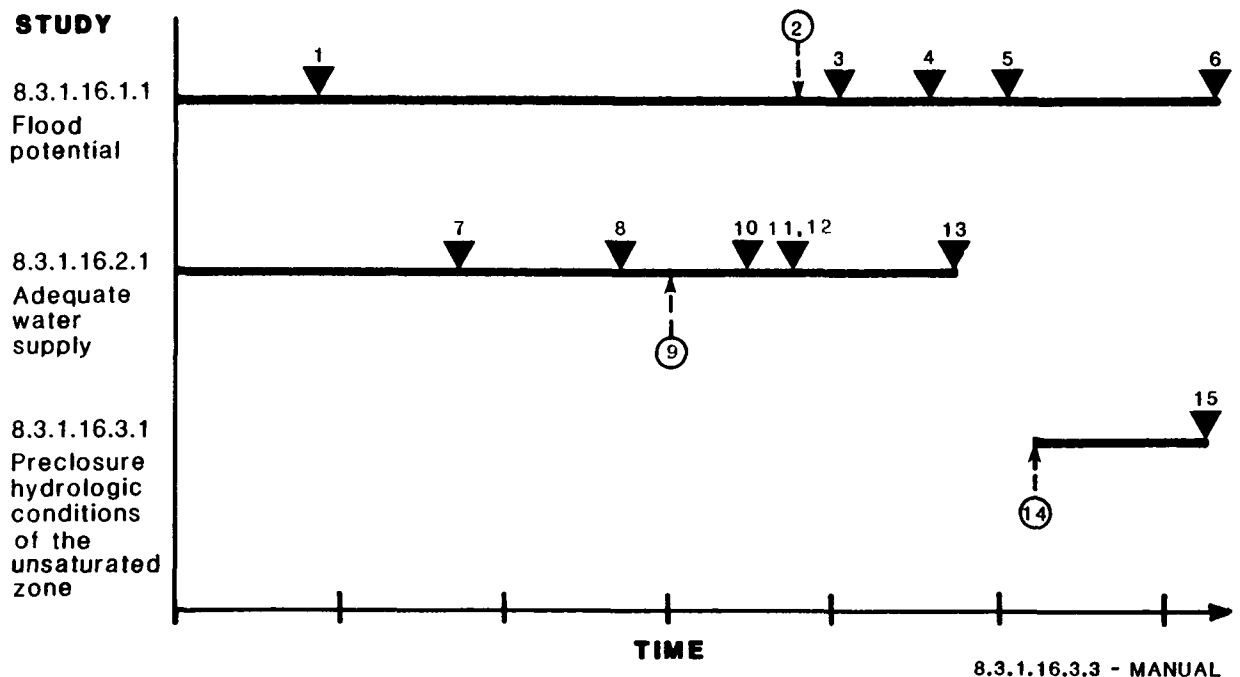

8.3.1.16.3.3 - MANUAL

CONSULTATION DRAFT

The points on the timeline and the data input and output at the interfaces are described in the following table:

<u>Point number</u>	<u>Description</u>
1	Milestone P794. Issue report on the potential for severe floods in Coyote Wash.
2	Data input from Sections 8.3.1.2 (geohydrology program), 8.3.1.5 (climate program), 8.3.1.12 (meteorology program), and 8.3.1.14 (surface characteristics program).
3	Milestone P923. Issue report summarizing prehistoric flooding at Yucca Mountain.
4	Milestone P935. Issue report summarizing modern flooding events and debris transport.
5	Milestone P787. Issue report on predictions of future flooding and debris movement due to climate changes.
6	Milestone Z494. Issue report on characterization of runoff and streamflow for Yucca Mountain and vicinity.
7	Milestone Z246. Issue report on repository-related water supply alternatives.
8	Milestone R599. Issue preliminary report on analysis of well completions for J-12 and J-13.
9	Data input from Sections 8.3.1.2 (geohydrology program), 8.3.1.9 (human interference program), and advanced conceptual design.
10	Milestone R600. Complete test plans for wells J-12 and J-13.
11	Milestone R601. Issue preliminary report on performance testing of wells J-12 and J-13.
12	Milestone Z247. Issue preliminary report on water-use requirements and constraints.
13	Milestone T040. Issue final report on the potential effects of water withdrawals on the local flow system.
14	Data input from Section, 8.3.1.2 (geohydrology program).
15	Milestone Q124. Issue report on ground-water conditions within and above the potential host rock.

Nuclear Waste Policy Act
(Section 113)

Section 8.3.1.17

Consultation Draft

PRECLOSURE TECTONICS



Site Characterization Plan

Yucca Mountain Site, Nevada Research and Development Area, Nevada

Volume V

January 1988

U.S. Department of Energy
Office of Civilian Radioactive Waste Management
Washington, DC 20585

CONSULTATION DRAFT

8.3.1.17 Overview of preclosure tectonics: Description of tectonic and igneous events required by performance and design requirements

Summary of performance and design requirements for preclosure tectonics information

The preclosure tectonics program (Program 8.3.1.17) is designed to develop an understanding of and to characterize the tectonic events and processes that could impact proposed repository structures, systems, or components considered to be important to safety through the operational phase; i.e., until permanent closure is achieved. In addition, characterizations of tectonic processes and events will be developed for consideration in the design and operation of certain structures, systems, and components required for exercising the retrieval option. Tectonic processes and events that are relevant to waste isolation following permanent closure will be investigated within the postclosure tectonics program (Program 8.3.1.8).

Performance and design issues that require data from the preclosure tectonics program are indicated in the left half of Figure 8.3.1.17-1; the right half of the figure indicates investigations that provide the requested data. Data requirements come from Issue 4.4 (Section 8.3.2.5), which evaluates the technical feasibility of repository construction, operation, closure, and decommissioning, and from postclosure Issue 1.12 (Section 8.3.3.2), which considers the design of seals for shafts, drifts, and boreholes. Investigations of technical feasibility include data requirements from three additional performance and design issues, also noted in Figure 8.3.1.17-1. These three issues are preclosure radiological safety (Issue 2.7, Section 8.3.2.3), potential radiologic exposure to the public due to credible accidents (Issue 2.3, Section 8.3.5.5), and preservation of the waste retrieval option (Issue 2.4, Section 8.3.5.2). In addition, data developed by the preclosure tectonics program will be used by the postclosure tectonics program (Program 8.3.1.8) and the preclosure and postclosure rock characteristics programs (Programs 8.3.1.15 and 8.3.1.4).

The evaluation of technical feasibility (Issue 4.4, Section 8.3.2.5) establishes the major requirement for characterizing potentially disruptive tectonic events.

The required characterization data are summarized in the (a) parts of Tables 8.3.1.17-1 through 8.3.1.17-6; the (b) parts of these tables provide summary information on the characterization program designed to provide the required data. The technical content of these tables is discussed in detail below. The data requirements are organized by the type of potential tectonic event: volcanic, including eruption and ashfall; faulting; and vibratory ground motion from natural earthquakes and underground nuclear explosions. Two tables are presented for each type of event, one for considerations of surface facilities and one for underground facilities.

The following information is used to specify each data requirement: design and performance parameters, to specify the type of data that is required; goal, to establish the precision or level of conservatism that is required; and needed confidence, to indicate the degree of certainty that the goal will be met. The needed confidences are specified using the terms high, medium, and low to denote the relative importance of each parameter-goal pair

**PERFORMANCE AND DESIGN ISSUES
CALLING FOR DATA**

**SITE
PROGRAMS**

**ASSESSMENT
INVESTIGATIONS**

**KEY DATA
COLLECTION
AND ANALYSIS
INVESTIGATIONS**

8.3.1.17-2

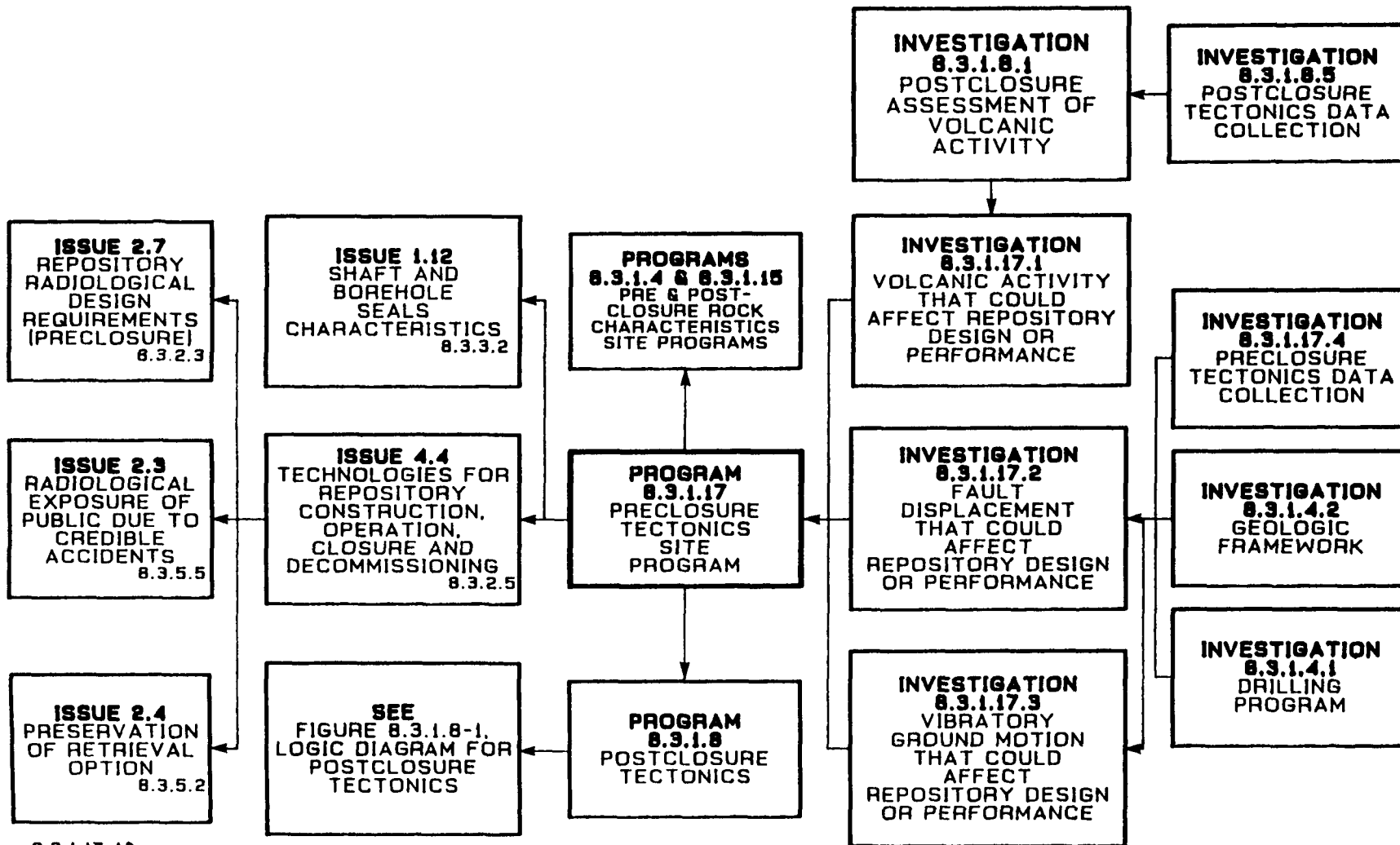

CONSULTATION DRAFT

8.3.1.17-1A

Figure 8.3.1.17-1. Logic diagram for the preclosure tectonics site program

Table 8.3.1.17-1(a). Design and performance parameters related to surface facilities and preclosure volcanic activity

Design or performance parameter ^a	Goal	Needed confidence	Characterization parameters
Probability of volcanic eruption that would disrupt surface facilities	Less than 1 chance in 10,000 in 100 yr	High	Annual probability of volcanic disruption at the site
Design-basis ash-fall thickness for facilities important to safety (FITS) ventilation systems	Less than 1 chance in 10 of exceeding design-basis ash-fall thickness in 100 yr	Low to Medium	Probability of ash fall at the site as a function of ash-fall thickness 1,000 yr(+) ash-fall thickness at the site
Ash-fall particle density and size distribution	TBD ^b	Low to Medium	Potential density and distribution of ash-fall particles

^aThese parameters are from Issue 4.4 (technical feasibility, Section 8.3.2.5), and corresponding performance measures are given in that issue.

^bTBD = to be determined.

Table 8.3.1.17-1(b). Characterization parameters related to surface facilities and preclosure volcanic activity

Characterization parameters	Testing basis			Key studies/activities supplying parameters
	Current estimate (range)	Confidence in current estimate	Needed confidence in final values	
Annual probability of volcanic disruption at the site	10^{-7} to 10^{-9} per yr	Moderate	Medium to high	8.3.1.8.1.1.4 -- Probability calculation (of volcanic disruption) and assessment
Probability of ash fall at the site as a function of ash-fall thickness	TBD ^a	TBD	Low to medium	8.3.1.17.1.1.2 -- Assess potential ash-fall thickness at the site
1,000 yr(+) ash-fall thickness at the site	0.1-2.0 cm	Low	Low to medium	8.3.1.17.1.1.2 -- Assess potential ash-fall thickness at the site
Potential density and distribution of ash-fall particles	TBD	TBD	Low to medium	8.3.1.17.1.1.3 -- Assess potential density and size distribution of ash-fall at the site

^aTBD = to be determined.

8.3.1.17-4

CONSULTATION DRAFT

Table 8.3.1.17-2(a). Design and performance parameters related to underground facilities and preclosure volcanic activity

Design or performance parameter ^a	Goal	Needed confidence	Characterization parameters
Probability of volcanic eruption through the underground facilities	Less than 1 chance in 10,000 in 100 yr	High	Annual probability of volcanic disruption of the underground facilities
Design-basis ash-fall thickness (at ventilation shaft locations)	Less than 1 chance in 10 of exceeding design-basis ash-fall thickness in 100 yr	Low to Medium	Probability of ash fall at the site as a function of ash-fall thickness 1,000 yr(+) ash-fall thickness at the site
Ash-fall particle density and size distribution	TBD ^b	Low to Medium	Potential density and size distribution of ash-fall particles

^aThese parameters are from Issue 4.4 (technical feasibility, Section 8.3.2.5), and corresponding performance measures are given in that issue.

^bTBD = to be determined.

Table 8.3.1.17-2(b). Characterization parameters related to underground facilities and preclosure volcanic activity

Characterization parameters	Current estimate (range)	Testing basis		Key studies/activities supplying parameters
		Confidence in current estimate	Needed confidence in final values	
Annual probability of volcanic disruption of the underground facilities	4.7×10^{-8} to 3.3×10^{-10} per yr	Medium	Medium to high	8.3.1.8.1.1.4 -- Probability calculation (of volcanic disruption) and assessment
Probability of ash fall at the site as a function of ash-fall thickness	TBD ^a	TBD	Low to medium	8.3.1.17.1.1.2 -- Assess potential ash-fall thickness at the site
1,000 yr(+) ash-fall thickness	0.1-2.0 cm	Low	Low to medium	8.3.1.17.1.1.2 -- Assess potential ash-fall thickness at the site
Potential density and size distribution of ash-fall particles	TBD	TBD	Low to medium	8.3.1.8.1.1.3 -- Assess potential particulate size distribution of ash-fall at the site

^aTBD = to be determined.

Table 8.3.1.17-3(a). Design and performance parameters related to surface facilities and preclosure fault displacement (page 1 of 2)

Design or performance parameter ^a	Goal	Needed confidence	Characterization parameters
Identification of any fault within 100 m of facilities important to safety (FITS) with greater than 1 chance in 100 of producing more than 5 cm of surface offset during the preclosure period (approximately 100 yr)	Determine existence	High	Identification and characterization of potentially significant Quaternary faults within 5 km of FITS
If existence is determined, establish			
Classification Location at surface Orientation at surface	Standard practice ±5 m ±10°	High High High	Identification and characterization of faults within 100 m of FITS that have apparent Quaternary slip rates >0.001 mm/yr or that measurably offset materials less than 10,000 yr old

8.3.1.17-7

CONSULTATION DRAFT

Table 8.3.1.17-3(a). Design and performance parameters related to surface facilities and preclosure fault displacement (page 2 of 2)

Design or performance parameter ^a	Goal	Needed confidence	Characterization parameters
Total probability of exceeding 5 cm fault displacement at locations proposed for FITS	Less than 1 chance in 100 of exceeding 5 cm displacement beneath surface FITS in 100 yr	High	Estimate of total probability for >5 cm displacement beneath FITS, considering known and possibly concealed faults and tectonic interrelationships among local faults

^aThese parameters are from Issue 4.4 (technical feasibility, Section 8.3.2.5), and corresponding performance measures are given in that issue.

Table 8.3.1.17-3(b). Characterization parameters related to surface facilities and preclosure fault displacement

Characterization parameters	Testing basis			Key studies/activities supplying parameters
	Current estimate (range)	Confidence in current estimate	Needed confidence in final values	
Identification and characterization of potentially significant Quaternary faults within 5 km of facilities important to safety (FITS)	4 such faults	Low	Medium to high	8.3.1.17.4.6.1 -- Evaluate Quaternary geology and potential Quaternary faults at Yucca Mountain
Identification and characterization of faults within 100 m of FITS that have apparent Quaternary slip rates > 0.001 mm/yr or that measurably offset materials less than 100,000 yr old	No such faults	Low	High	8.3.1.17.4.2.2 -- Conduct exploratory trenching in Midway Valley
Estimate of total probability for >5 cm displacement beneath FITS, considering known and possibly concealed faults and tectonic inter-relationships among local faults	Less than 1 chance in 100 of exceeding 5 cm displacement beneath FITS in 100 yr	Low	High	8.3.1.17.2.1.1 -- Assess the potential for surface faulting at prospective sites of surface FITS

8.3.1.17-9

CONSULTATION DRAFT

Table 8.3.1.17-4(a). Design and performance parameters related to underground facilities and preclosure fault displacement (page 1 of 2)

Design or performance parameter ^a	Goal	Needed confidence	Characterization parameters
<p>Identification and characterization of significant late Quaternary faults in the repository block:</p> <p>Classification Location at surface Orientation at surface</p>	<p>Standard practice ±5 m ±10°</p>	<p>High High High</p>	<p>Surface locations of faults in the repository with > 1 m offset of Quaternary materials or with > 100 m offset of Tertiary rocks</p>
<p>Identification and characterization of any fault within the waste emplacement area with greater than 1 chance in 100 of producing more than 7 cm (waste-package air-gap distance) of subsurface offset during the preclosure period (approximately 100 yr)</p>	<p>Determine existence; for any such faults (none are now known to exist), determine location within the waste emplacement area</p>	<p>High</p>	<p>Surface and subsurface locations of faults with Quaternary slip rates > 0.005 mm/yr that intersect underground facilities</p>

8.3.1.17-10

CONSULTATION DRAFT

Table 8.3.1.17-4(a). Design and performance parameters related to underground facilities and preclosure fault displacement (page 2 of 2)

Design or performance parameter ^a	Goal	Needed confidence	Characterization parameters
Total probability of exceeding 7 cm fault displacement on any fault that intersects areas of waste emplacement	Less than 1 chance in 10 in 100 yr of exceeding 7 cm displacement on any fault that intersects areas of waste emplacement	Medium	Estimated total probability of fault displacement exceeding 7 cm in areas of emplaced waste, considering known and possibly concealed faults and tectonic interrelationships among local faults

^aThese parameters are from Issue 4.4 (technical feasibility, Section 8.3.2.5), and corresponding performance measures are given in that issue.

Table 8.3.1.17-4(b). Characterization parameters related to the underground facilities and preclosure fault displacement

Characterization parameters	Testing basis			Key studies/activities supplying parameters
	Current estimate (range)	Confidence in current estimate	Needed confidence in final values	
Surface locations of faults in the repository block with >1 m offset of Quaternary materials or with >100 m offset of Tertiary rocks	2 such faults exist	Low to medium	Medium	8.3.1.17.4.6.1 -- Evaluate Quaternary geology and potential Quaternary faults at Yucca Mountain
Surface and subsurface locations of faults with Quaternary slip rates >0.005 mm/yr that intersect underground facilities	No such faults exist	Medium	Medium to High	8.3.1.17.4.6.1 -- Evaluate Quaternary geology and potential Quaternary faults at Yucca Mountain 8.3.1.17.4.6.2 -- Evaluate age and recurrence of movement on suspected and known Quaternary faults within the site area 8.3.1.17.4.7 -- Subsurface geometry and concealed extensions of Quaternary faults at Yucca Mountain
Estimated total probability of fault displacement exceeding 7 cm in areas of emplaced waste, considering known and possibly concealed faults and tectonic interrelationships among local faults	Less than 1 chance in 100 in 100 yr of exceeding 7 cm displacement in areas of emplaced waste	Medium	Medium	8.3.1.17.2.1.2 -- Assess the potential for rupture on faults that intersect underground facilities

8.3.1.17-12

CONSULTATION DRAFT

Table 8.3.1.17-5(a). Design and performance parameters related to surface facilities and preclosure vibratory ground motion (page 1 of 4)

Design or performance parameter ^a	Goal	Needed confidence	Characterization parameters
Design-basis ground motion time histories (minimum band width = 0.5 to 33 Hz) and corresponding response spectra (at 1 Hz intervals) for surface facilities important to safety (FITS)	Representative of 10,000-year cumulative slip earthquakes on nearby faults, or maximum potential underground nuclear explosions (UNEs) that would control site ground motion at any frequency between 0.5 and 33 Hz (including any effect of local geology or building embedment)	Medium to high	<p>Identification of potential earthquake sources in the controlled area</p> <p>Potentially relevant earthquake sources in the region (≤ 100 km)</p> <p>Magnitude of 10,000-year cumulative slip earthquakes on local sources</p> <p>Magnitude of 10,000-year cumulative slip earthquakes on regional sources</p> <p>Maximum future UNE</p> <p>Closest distance of future UNEs</p> <p>Ground motion attenuation with distance</p>

8.3.1.17-13

CONSULTATION DRAFT

Table 8.3.1.17-5(a). Design and performance parameters related to surface facilities and preclosure vibratory ground motion (page 2 of 4)

Design or performance parameter ^a	Goal	Needed confidence	Characterization parameters
Combined potential for vibratory ground motion at FITS, considering all faults	Less than 1 chance in 10 of exceeding design-basis ground motion in 100 yr	Medium to high	Spectral modification due to local geology
			Controlling ground motion event(s)
			Time histories and response spectra representative of controlling event(s)
			Identification of potential earthquake sources in the controlled area
			Potentially relevant earthquake sources in the region (≤ 100 km)
			Earthquake recurrence relationships for local and regional sources
			Ground motion attenuation with distance

8.3.1.17-14

CONSULTATION DRAFT

Table 8.3.1.17-5(a). Design and performance parameters related to surface facilities and preclosure vibratory ground motion (page 3 of 4)

Design or performance parameter ^a	Goal	Needed confidence	Characterization parameters
Probability versus peak acceleration, peak velocity, and peak velocity response at selected frequencies, at surface locations of FITS	Values estimated for annual probabilities ranging from 10^{-2} to 10^{-6} per yr	Medium	Spectral modification due to local geology
			Ground motion exceedance probabilities
			Identification of potential earthquake sources in the controlled area
			Potentially relevant earthquake sources in the region (≤ 100 km)
			Earthquake recurrence relationships for local and regional sources
			Ground motion attenuation with distance
			Spectral modification due to local geology

Table 8.3.1.17-5(a). Design and performance parameters related to surface facilities and preclosure vibratory ground motion (page 4 of 4)

Design or performance parameter ^a	Goal	Needed confidence	Characterization parameters
			Ground motion exceedance probabilities

^aThese parameters come from Issues 4.4 (technical feasibility, Section 8.3.2.5) and 1.12 (seal characteristics, Section 8.3.3.2), and corresponding performance measures are given in those issues.

Table 8.3.1.17-5(b). Characterization parameters related to surface facilities and preclosure vibratory ground motion (page 1 of 3)

Characterization parameters	Testing basis			Key studies/activities supplying parameters
	Current estimate (range)	Confidence in current estimate	Needed confidence in final values	
Identification of potential earthquake sources in the controlled area	See Chapter 1	Medium	Medium to high	8.3.1.17.3.1.1 -- Identify relevant earthquake sources
Potentially relevant earthquake sources in the region (≤ 100 km)	See Chapter 1	Low to medium	Medium	8.3.1.17.3.1.1 -- Identify relevant earthquake sources
Magnitude of 10,000-year cumulative slip earthquakes on local sources	$\approx 6 \frac{1}{2}$	Low to medium	Medium to high	8.3.1.17.3.1.2 -- Define 10,000-year cumulative slip earthquakes for relevant sources
Magnitude of 10,000-year cumulative slip earthquakes on regional sources	$6 \frac{1}{2}$ to $8 \frac{1}{2}$	Low	Medium	8.3.1.17.3.1.2 -- Define 10,000-year cumulative slip earthquakes for relevant sources
Maximum future underground nuclear explosion (UNE)	150-750 kt	Medium	Medium	8.3.1.17.3.2.2 -- Determine maximum UNE source(s)
Closest distance of future future UNEs	23 km (Buckboard Mesa area)	Medium	Medium	8.3.1.17.3.2.2 -- Determine maximum UNE sources

8.3.1.17-17

CONSULTATION DRAFT

Table 8.3.1.17 5(b). Characterization parameters related to surface facilities and preclosure vibratory ground motion (page 2 of 3)

Characterization parameters	Current estimate (range)	Testing basis		Key studies/activities supplying parameters
		Confidence in current estimate	Needed confidence in final values	
Ground motion attenuation with distance	Published models for California and western U.S.	Low to medium	Medium	8.3.1.17.3.3 -- Ground motion from earthquakes and UNRs
Spectral modification at facilities important to safety due to local geology	1/2 to 4	Low	Medium	8.3.1.17.3.4 -- Effects of local geology on surface and subsurface motions
Controlling ground motion event(s)	≈ 6 1/2 M earthquake on Paintbrush Canyon	Low to medium	Medium to high	8.3.1.17.3.5.1 -- Identify controlling seismic events
Time histories and response spectra representative of controlling event(s)	TBD ^a (0.4-0.6g peak acceleration)	Low to medium	Medium to high	8.3.1.17.3.5.2 -- Characterize ground motion from controlling seismic events
Earthquake recurrence relationships for local and regional sources	See section 1.4.2	Low to medium	Medium	8.3.1.17.3.6.1 -- Evaluate earthquake sources

8.3.1.17-18

CONSULTATION DRAFT

Table 8.3.1.17-5(b). Characterization parameters related to surface facilities and preclosure vibratory ground motion (page 3 of 3)

Characterization parameters	Testing basis			Key studies/activities supplying parameters
	Current estimate (range)	Confidence in current estimate	Needed confidence in final values	
Ground motion exceedance probabilities	1.5 x 10 ⁻⁴ /yr for 0.5g	Low to medium	Medium	8.3.1.17.3.6.2 -- Evaluate ground motion probabilities

^aTBD = to be determined.

Table 8.3.1.17-6(a). Design and performance parameters related to underground facilities and preclosure vibratory ground motion (page 1 of 4)

Design or performance parameter ^a	Goal	Needed confidence	Characterization parameters
Design-basis ground motion time histories and corresponding response spectra for underground facilities (at various depths) (minimum band width = 0.5 to 33 Hz; 1 Hz interval for response spectra)	Representative of 10,000-year cumulative slip earthquakes or nearby faults, or maximum potential underground nuclear explosions (UNEs) that would control site ground motion at any frequency between 0.5 and 33 Hz (including any effects of local geology or depth of burial)	Medium	<p>Identification of potential earthquake sources in the controlled area</p> <p>Potentially relevant earthquake sources in the region (≤ 100 km)</p> <p>Magnitude of 10,000-year cumulative slip earthquakes on local sources</p> <p>Magnitude of 10,000-year cumulative slip earthquakes on regional sources</p> <p>Future maximum UNE</p> <p>Closest distance of future UNEs</p> <p>Ground motion attenuation with distance</p>

8.3.1.17-20

CONSULTATION DRAFT

Table 8.3.1.17-6(a). Design and performance parameters related to underground facilities and preclosure vibratory ground motion (page 2 of 4)

Design or performance parameter ^a	Goal	Needed confidence	Characterization parameters
Combined potential for vibratory ground motion at underground facility locations, considering all faults	Less than 1 chance in 10 of exceeding design-basis ground motion in 100 yr	Medium	Spectral modification due to local geology and depth of burial
			Controlling ground motion event(s)
			Time histories and response spectra representative of of controlling event(s)
			Identification of potential earthquake sources in the controlled area
			Potentially relevant earthquake sources in the region (≤ 100 km)
			Earthquake recurrence relationships for local and regional sources

8.3.1.17-21

CONSULTATION DRAFT

Table 8.3.1.17 6(a). Design and performance parameters related to underground facilities and preclosure vibratory ground motion (page 3 of 4)

Design or performance parameter ²	Goal	Needed confidence	Characterization parameters
Probability versus peak acceleration, peak velocity, and peak velocity response at selected frequencies at underground facility locations	Values estimated for annual probabilities ranging from 10^{-2} to 10^{-6} per yr	Low to medium	Ground motion attenuation with distance
			Spectral modification due to local geology and depth of burial
			Ground motion exceedance probabilities
			Identification of potential earthquake sources in the controlled area
			Potentially relevant earthquake sources in the region (≤ 100 km)
			Earthquake recurrence relationships for local and regional sources

8.3.1.17-22

CONSULTATION DRAFT

Table 8.3.1.17 6(a). Design and performance parameters related to underground facilities and preclosure vibratory ground motion (page 4 of 4)

Design or performance parameter ^a	Goal	Needed confidence	Characterization parameters
			Ground motion attenuation with distance
			Spectral modification due to local geology and depth of burial
			Ground motion exceedance probabilities

^aThese parameters are from Issues 4.4 (technical feasibility, Section 8.3.2.5) and 1.12 (seal characteristics, Section 8.3.3.2), and corresponding performance measures are given in those issues.

Table 8.3.1.17-6(b). Characterization parameters related to underground facilities and preclosure vibratory ground motion (page 1 of 3)

Characterization parameters	Current estimate (range)	Testing basis		Key studies/activities supplying parameters
		Confidence in current estimate	Needed confidence in final values	
Identification of potential earthquake sources in the controlled area	See Chapter 1	Medium	Medium	8.3.1.17.3.1.1 -- Identify relevant earthquake sources
Potentially relevant earthquake sources in the region (≤ 100 km)	See Chapter 1	Low to medium	Medium	8.3.1.17.3.1.1 -- Identify relevant earthquake sources
Magnitude of 10,000-year cumulative slip earthquakes on local sources	$\approx 6 \frac{1}{2}$	Low to medium	Medium to high	8.3.1.17.3.1.2 - Define 10,000-year cumulative slip earthquakes for relevant sources
Magnitude of 10,000-year cumulative slip earthquakes on regional sources	$6 \frac{1}{2}$ to $8 \frac{1}{2}$	Low	Medium	8.3.1.17.3.1.2 -- Define 10,000-year cumulative slip earthquakes for relevant sources
Maximum future underground nuclear explosion (UNE)	150-750 kt	Medium	Medium	8.3.1.17.3.2.2 -- Determine maximum UNE source(s)
Closest distance of future future UNEs	23 km (Buckboard Mesa area)	Medium	Medium	8.3.1.17.3.2.2 -- Determine maximum UNE source(s)

8.3.1.17-24

CONSULTATION DRAFT

Table 8.3.1.17-6(b). Characterization parameters related to underground facilities and preclosure vibratory ground motion (page 2 of 3)

Characterization parameters	Testing basis			Key studies/activities supplying parameters
	Current estimate (range)	Confidence in current estimate	Needed confidence in final values	
Ground motion attenuation with distance	Published models for California and western U.S.	Low to medium	Medium	8.3.1.17.3.3 -- Ground motion from earthquakes and UNEs
Spectral modification due to local geology and depth of burial	1/4 to 1	Low	Medium	8.3.1.17.3.4 -- Effects of local geology on surface and subsurface motions
Controlling ground motion event(s)	≈ 6 1/2 M earthquake on Paintbrush Canyon fault	Low to medium	Medium	8.3.1.17.3.5.1 -- Identify controlling seismic events
Time-histories and response spectra representative of controlling event(s)	TBD ^a	Low to medium	Medium	8.3.1.17.3.5.2 -- Characterize ground motion from controlling seismic events
Earthquake recurrence relationships for local and regional sources	See section 1.4.2	Low to medium	Medium	8.3.1.17.3.6.1 -- Evaluate earthquake sources

8.3.1.17-25

CONSULTATION DRAFT

Table 8.3.1.17-6(b). Characterization parameters related to underground facilities and preclosure vibratory ground motion (page 3 of 3)

Characterization parameters	Testing basis			Key studies/activities supplying parameters
	Current estimate (range)	Confidence in current estimate	Needed confidence in final values	
Ground motion exceedance probabilities	10^{-4} /yr for 0.5g	Low	Low to medium	8.3.1.17.3.6.2 -- Evaluate ground motion probabilities

^aTBD = to be determined.

CONSULTATION DRAFT

for contributing to the resolution of design and performance issues. High confidence indicates that the parameter is of primary importance, and, consequently, that the goal should be met by a characterization of the parameter that conservatively accounts for residual uncertainties. Low confidence indicates that resolution of design and performance issues is not strongly influenced by the parameter and that the goal should be met by a best estimate of the parameter, based on limited data. Medium confidence is used for parameters of intermediate importance.

Investigations performed to satisfy the data requirements will produce information that will also be used by the Postclosure Tectonics Program (8.3.1.8), and conversely, investigations performed by that program will provide information that will be used in the preclosure tectonics program. The postclosure tectonics program requires information on (1) current seismicity, to help evaluate tectonic processes, including the presence of magma bodies; (2) the potential for earthquake ground motions, to support evaluations of the stability of underground facilities; (3) the potential for fault displacement, to support evaluations of possible disruption of waste packages and to support evaluations of possible changes in the hydrologic environment; and (4) tectonic stress and rate of tectonic deformations, to support evaluations of possible changes in the hydrologic environment. The postclosure tectonics program will supply information on the potential for local volcanic eruptions to support the preclosure tectonics program in the characterization of such events. Technical considerations of the information contained in Tables 8.3.1.17-1 through 8.3.1.17-6 are discussed in the next section, on the approach to satisfying the performance and design requirements.

Approach to satisfying performance and design requirements

General methodology

The approach that has been developed to satisfy performance and design requirements is based on current knowledge and uncertainties about the local tectonic environment, and consideration has been given to state-of-the-art capabilities for resolving or bounding the effects of these uncertainties. The design and characterization parameters that will be used to satisfy performance and design requirements are listed in Tables 8.3.1.17-1(b) through 8.3.1.17-6(b).

For each data requirement presented in the tables, one or more characterization parameters have been identified to serve as the technical basis for satisfying the requirement. The tables also present current estimates for the characterization parameters (where available and quantifiable) along with assessments of the current confidence in these estimates and the confidences needed to satisfy the data requirement. Differences between the current and needed confidence for each characterization parameter provide a measure of the remaining amount of work that is required to finalize the result. The last column of Tables 8.3.1.17-1(b) through 8.3.1.17-6(b) lists the key studies or activities that will be providing results for each characterization parameter, and the corresponding section numbers where descriptions of these studies and activities are provided. The technical considerations summarized in these tables are discussed below.

CONSULTATION DRAFT

The tectonic characteristics of the site will be investigated in sufficient scope and detail to provide reasonable assurance that the processes are understood and that the characterization parameters are determined with the confidences specified in Tables 8.3.1.17-1 through 8.3.1.17-6. The investigations will use data from a variety of sources, including scientific literature, current and historical seismicity, geologic maps, logs from boreholes and surface trenches, gravity surveys, aeromagnetic and paleomagnetic observations, seismic reflection and refraction profiles, and magnetotelluric soundings.

The planned approach is to use both deterministic and probabilistic methods for analyzing the effects of tectonic events during the preclosure period. The deterministic approach will be used to model cause-and-effect mechanisms and to develop particular tectonic event scenarios in greater detail than is typically provided by probabilistic methods. In addition, all final results for volcanic, faulting, and ground-motion events will be evaluated using probabilistic methods (1) to ensure that adequate consideration is given to the full range of potential tectonic processes and to their associated uncertainties, and (2) to help identify those processes that are key to characterizing the geologic hazards at the site.

Using the deterministic approach, results (e.g., ground motions) will be determined for specific events that are postulated to occur (e.g., an earthquake or an underground nuclear explosion). Judgment is required for postulating the specific source events to ensure adequate conservatism. The deterministic approach will be used to establish ground-motion conditions to be considered in the next phase of design (advanced conceptual design) and, if appropriate, in the final design. This approach is suited to the determination of detailed ground-motion conditions that would likely be produced by postulated earthquakes and underground nuclear explosions (UNEs), including the amplitude and duration of shaking over the frequency band relevant to design. Because source events that will be postulated are not likely to change as more refined fault data become available, the resulting motions are expected to provide a stable basis for use in design.

The probabilistic approach will be used to characterize the range of possible seismic-source interpretations as constrained by contemporary knowledge about the local tectonic framework, including uncertainties. In addition to the cause-and-effect relationships basic to the deterministic approach, the probabilistic approach facilitates consideration of the full range of potential source events (e.g., earthquakes of varying magnitude and distance) in conjunction with probability estimates that the various source events will occur (e.g., spatially varying recurrence relationships for earthquakes of varying magnitude) and probability estimates that a particular outcome will result from the various source events, assuming they do occur. The probabilistic approach will explicitly quantify the effect of including uncertainty in interpretations on the estimated seismic hazard.

The current plan is to apply probabilistic methods for evaluating adequacy of deterministic final results. These methods will also be useful for constraining the technical judgments required for postulating deterministic source events and to help focus field investigations on the resolution of those conditions most relevant to satisfying the performance and design

CONSULTATION DRAFT

requirements. Probabilistic methods will also be used to provide input for the assessment of risk of accidental release of radionuclides.

Review of the local tectonic environment

Consideration of local faults with evidence of movement during the Quaternary period (about the last 2 million years) is essential to the characterization of the potential for fault displacement and vibratory ground motions at the site of repository facilities. Fault data that are particularly relevant to the characterization approach are reviewed here; more detailed information is presented in Section 1.3.2.2.2.

Figure 8.3.1.17-2 shows north-trending faults with evidence of Quaternary movement on both the east and west side of Yucca Mountain. Midway Valley, the proposed location of the waste handling facilities on the east side of Yucca Mountain, is bounded to the east and west, respectively, by the Paintbrush Canyon and Bow Ridge faults. The Solitario Canyon fault passes just west of the proposed underground facilities, and the Windy Wash fault lies a few kilometers farther to the west. The Ghost Dance fault, on the east side of the repository block, may not have moved in the Quaternary, but evidence confirming this has not yet been obtained.

It is possible that other faults in the site area have experienced movement during the Quaternary period. (The site area is defined for this section as the rectangular 237 km^2 (91 mi^2) area encompassing the central Yucca Mountain block and its structural and physiographic boundaries (Fortymile Wash, Yucca Wash, Solitario Canyon, and the Stagecoach Road fault.) These faults include the northeast-trending Stagecoach Road and Rock Valley faults and postulated detachment faults (the Rock Valley fault, outside the area shown in figure 8.3.1.17-2, is discussed in Section 8.3.1.17.4.4). The approach discussed here for evaluating faulting and ground motion potential is intended to include conservative characterizations of such faults. As yet unidentified Quaternary faulting is particularly likely at the southern extent of the site area, as discussed subsequently.

The Paintbrush Canyon, Bow Ridge, Solitario, and Windy Wash faults show evidence of normal dip-slip movement along surfaces that dip steeply to the west (see Figure 1-32 of Section 1.3.2.2.2). The lengths of these faults have not been precisely determined, either because their projected trace is obscured by late Quaternary deposits without recognized geomorphic expression of the faults, or because potential linkages between discrete faults segments have not been unambiguously established. However, on the basis of published mapping, the length of the Paintbrush Canyon Fault is inferred to be 17 to 31 km, the Bow Ridge fault 10 to 19 km, the Solitario Canyon Fault 15 to 17 km, and the Windy Wash Fault 6 to 19 km (Table 1-8, Section 1.3.2.2.2). The Paintbrush Canyon Fault could be longer than the estimate given above if it links at its southern end to the Stagecoach Road Fault (see Figure 8.3.1.17-2).

Quaternary deposits are demonstrably offset by the faults at scattered localities along their trace. Preliminary study of the faults at a few of these localities, using trenching and dating of offset Quaternary deposits, indicates that reliably dated middle-to late Quaternary soils have been offset by dip-slip movement on the faults at rates up to approximately 0.01 mm/yr.

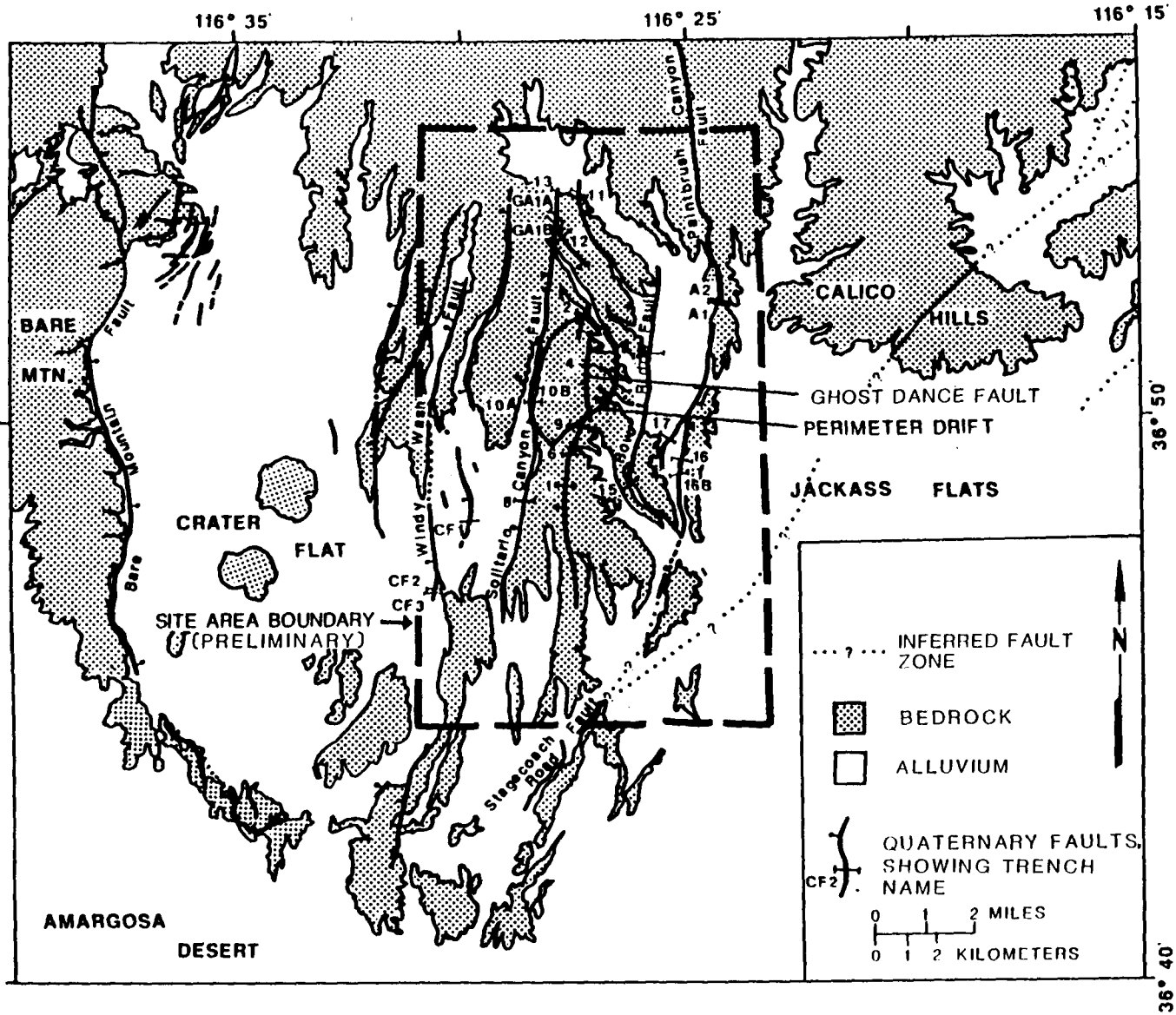

Figure 8.3.1.17-2. Quaternary normal faults and postulated detachment faults on or near Yucca Mountain. Modified from Swadley et al. (1984), USGS (1984), and Reheis (1986).

CONSULTATION DRAFT

Uncertainty in slip-rate values exists due to uncertainty in the age of soil layers, particularly ash layers. Slip-rate values will have to be revised if new age dates become available. Lateral offset of Quaternary deposits that indicate a strike-slip component of fault movement have not been recognized but cannot be ruled out on the basis of available data.

The Paintbrush Canyon fault, which dips under Midway Valley, is particularly important for evaluating the potential for future vibratory ground motion at the proposed site of the waste-handling facilities. Considering the length and nature of this fault, it could have been the source of moderate earthquakes (M 6 1/2) in the past, although such events would appear to be rare based on the low rate of movement. Assuming the Quaternary rate of displacement for the Paintbrush Canyon fault is about 0.01 mm/yr, the recurrence time between magnitude 6 1/2 earthquakes on this fault should be about 50,000 yr (Slemmons and Depolo, 1986). If larger-magnitude earthquakes were postulated for this feature, their recurrence times would be longer. Long recurrence intervals appear to be typical of the local faults (Sections 1.3 and 1.5). Whitney et al. (1986) have estimated the recurrence interval between faulting events on the Windy Wash fault to be about 70,000 yr. Further investigations will be performed to test this conclusion.

The Bare Mountain fault, about 18 km west of Midway Valley, appears to be a more likely source of a moderate earthquake than the local faults (Section 1.4.2). Dated displacements presented in Table 1-8 indicate that this fault appears to be over ten times as active as the local faults. Thus, the Bare Mountain fault may be a significant contributor to probabilistic assessments of future ground motions at the site. Also, this fault, which dips eastward and southeastward (along its northern extent), may be tectonically linked at depth to the local faults (which dip to the west) via a detachment fault or graben structure.

The east-west spacing between adjacent local faults, illustrated in Figure 8.3.1.17-2, is less than their mapped lengths, and less than the 10 to 15 km thickness of the seismogenic zone found in this area (Section 1.4). The close proximity of the local faults suggests the possibility of interconnections at depth, most notably between the Paintbrush Canyon and the Bow Ridge faults, which appear to converge near their southern extent. One important hypothesis is that the local north-trending faults flatten with depth and merge into a detachment fault that dips gently to the west (See Section 1.3.2). Another possibility that must also be considered is that the local faults continue downward at a steep dip through the seismogenic zone with possible interconnections at intermediate depths. Until such uncertainties are resolved, the evaluation and characterization of potential ground motion and faulting at the site must allow for alternate interpretations of the local tectonics.

Considerations of volcanic activity

A volcanic eruption within close proximity to the repository facilities could be highly disruptive. Current estimates described in Section 1.5.1.2.3 indicate that the probability of such an event is well below that considered to be significant for the preclosure time period. Additional work will be

CONSULTATION DRAFT

conducted under the postclosure tectonics program (Investigation 8.3.1.8.1) to develop increased confidence in the probability estimates for a local eruption.

Significant deposition of volcanic ash on the surface of the repository could temporarily disrupt operations. However, the nearest silicic volcanism during the Quaternary is at the margins of the Great Basin (Crowe et al., 1983b). A thousand-year ashfall event will be characterized, but because of the considerable distances and infrequent occurrences, the event is not expected to be a significant design factor.

Tables 8.3.1.17-1(a) and 8.3.1.17-2(a) show information on ash fall thickness and particle size distribution for the design of ventilation systems for the surface and underground facilities, respectively. Analyses will be conducted using data already available in the literature (Investigation 8.3.1.17.1). Probabilistic methods will be used to characterize the results.

Consideration of fault displacement

As noted previously, faults with evidence of Quaternary displacement are present in the site area, and the possibility exists that additional, undetected faults may also be present. Significant displacement on a fault or along a distributed zone of faulting immediately adjacent to repository facilities could disrupt operations and damage facilities. Performance and design issues require characterization of the potential for fault displacement at the proposed site for surface facilities that are considered important to safety (Table 8.3.1.17-3(a)) and at the location of the underground facilities (Table 8.3.1.17-4(a)). Currently, the waste handling facilities are the only facilities considered to be important to safety (Section 6.2).

Faulting considerations are particularly important for establishing a suitably stable site for the waste handling facilities, currently planned for Midway Valley. The concern is for avoiding relative displacement at the base of the structural foundation in excess of a few inches; smaller displacement is not expected to cause serious damage. The primary goal expressed in Table 8.3.1.17-3(a) is to demonstrate, with a high degree of confidence, that there is less than a one-percent chance of exceeding 5 cm of fault displacement at the site of the waste handling facility in 100 yr.

This goal, which establishes the maximum allowable annual probability for exceeding 5 cm of fault displacement at 10^{-4} /yr, appears to be consistent with safety considerations for this and other types of facilities. For example, comparable and higher annual probabilities have been found to be acceptably conservative for the seismic designs of nuclear power plants to withstand vibratory motions (Reiter and Jackson, 1983). While this comparison is not analogous in several respects, the risk resulting from fault displacements in excess of 5 cm at the site of the waste handling facilities is probably less than the risk resulting from vibratory ground motions that exceed the design basis for a nuclear power plant, and therefore the comparison does provide a useful check on the acceptance goal for faulting.

CONSULTATION DRAFT

Another useful comparison can be made with criteria used to identify repository structures, systems, and components considered important to safety. Importance to safety is established if the probability of failure is greater than 10^{-5} /yr and if the failure would lead to radiation exposures of 0.5 rem or greater at or beyond the restricted area (Laub and Jardine, 1987). The annual probability that failure of this magnitude would result from faulting is expected to be less than 10^{-5} /yr for a site in which the annual probability for 5 cm of displacement is less than 10^{-4} /yr. This line of reasoning indicates that the goal for siting the waste handling facilities provides adequate safeguards to avoid areas of potentially significant faulting.

Additional field data are needed to achieve the required high degree of confidence in the determination of faulting probabilities. This need is indicated in Table 8.3.1.17-3(b) in which the current confidence in the values of the characterization parameters is considered to be low and the needed confidence is generally high.

Significant faulting is sometimes accompanied by sympathetic displacement at other locations. The first consideration then is to identify and characterize those faults within 5 km that could have significant impact on faulting at the proposed site. Geomorphic and other evidence that a Quaternary fault might trend toward Midway Valley in the vicinity of the site will be evaluated and characterized. Additional information will be obtained on the properties of the Paintbrush Canyon fault, which dips under the east side of Midway Valley, to evaluate the possibility of it becoming listric at shallow depth. Midway Valley will be carefully examined for geomorphic evidence of faulting, and trenching may be required to confirm the existence of suspected faults at distances up to one kilometer or more from the proposed site.

The most important data for constraining the possibilities for faulting at facilities important to safety are expected to come from extensive field investigations in the immediate site vicinity. Geologists will work with engineers in siting the waste-handling facilities to ensure that adequate stability is provided with respect to the possibility of faulting. Preliminary surveys may include small test pits or trenches to evaluate the stratigraphy and the possibility of previous local faulting. One or more trenches will be excavated across the site (or adjacent to the site) and extended to the east and the west beyond the proposed boundaries of the waste handling building, as needed. It is anticipated that these exploratory trenches will intersect surficial units that were deposited at least 100,000 yr ago (based on the results of mapping by Swadley et al., 1984). Cross Section B-B' in Scott and Bonk (1984) indicates that the alluvium of Midway Valley varies in thickness from zero meters at Exile Hill on the west side of the valley, to an undetermined amount in the valley center, to about 50 m in borehole UE-25 WT#5 near the Paintbrush Canyon fault on the east side of the valley.

Data on potentially significant faults in the area and data obtained in the immediate vicinity of the proposed site will be evaluated to estimate the annual probability for experiencing 5 cm of displacement at the site of the waste-handling facilities. This analysis will consider possible effects of

CONSULTATION DRAFT

known and unknown faults. Displacement amplitudes will also be estimated for annual probabilities ranging from 10^{-2} to 10^{-6} per yr for use in risk assessments.

Faulting conditions for underground facilities will also be evaluated. The primary issue here is that significant fault displacement could disrupt normal operations or impede execution of the option for waste retrieval.

The first requirement presented in Table 8.3.1.17-4(a) is to identify and characterize late Quaternary faults within close proximity of the proposed underground facilities. This requirement is to aid in developing the layout and design of underground facilities. The second part of the table notes that current data provide low to moderate confidence that two such faults exist; namely, the Bow Ridge fault and the Solitario Canyon fault. Further work is required to provide added confidence that there are no additional late Quaternary faults in this area.

A further requirement is presented in Table 8.3.1.17-4(a) to identify, characterize, and locate at the repository horizon any fault with greater than a one-percent chance of displacing more than 7 cm in the area of waste emplacement during the preclosure period. This requirement is to ensure viability of the waste-retrieval option. Less than 7 cm of fault displacement is not expected to significantly impact normal retrieval operations because the diameter of the waste package will be about 7.6 cm smaller than the diameter of the emplacement hole (See Section 8.3.2.5). Larger displacements might bind or shear the waste packages thereby creating off-normal conditions for waste retrieval.

Assuming a preclosure period of 100 yr, the requirement just discussed is to identify, characterize, and locate at depth any fault passing through the area of waste emplacement that has an annual probability greater than 10^{-4} /yr for displacing more than 7 cm. Assuming event recurrences are random in time, the average rate of slip for such a fault would need to be considerably larger than 7 cm per 10^4 yr (i.e., 0.007 mm/yr) to account for excess displacement from events that produce less than and more than 7 cm. Accordingly, the screening criterion presented in Table 8.3.1.17-4(b) for locating faults in the underground, an average Quaternary slip rate greater than 0.005 mm/yr, provides considerable margin with respect to requirements presented in the (a) part of this table.

As noted above, the Bow Ridge fault and the Solitario Canyon fault are late Quaternary faults within close proximity to the proposed underground facilities. The Bow Ridge fault crosses the planned access ramp that enters the repository block from the east. The rate of Quaternary displacement for the Bow Ridge fault is not well constrained. However, assuming the rate of activity is similar to other faults in the area, long recurrence intervals between faulting events would be expected. For example, Whitney et al. (1986) have identified four faulting sequences within about 270,000 yr on the Windy Wash fault, giving an average recurrence interval of about 70,000 yr between faulting events (Section 1.3.3.3.3). Preliminary estimates, assuming the local Quaternary faults have a similar rate of activity, indicate that the annual probability for exceeding 10 cm of displacement on faults such as the Bow Ridge fault is about 1×10^{-5} /yr (URS/Blume, 1987). Additional field investigations will be conducted to develop more information about the

CONSULTATION DRAFT

characteristics of this fault, particularly with respect to its Quaternary rate of activity. Design measures are being implemented to minimize possible fault-induced damage and to facilitate rapid repair in the unlikely event that movement should occur on this fault during the preclosure period.

The western boundary of the underground facilities will extend to the proximity of the Solitario Canyon fault, which is known to have Quaternary displacement. As with other local faults, the probability for experiencing significant displacement during the preclosure period appears to be well below that required by considerations for waste retrieval. Additional investigations will be conducted to further constrain fault characteristics, particularly the possibility of extension of the Solitario Canyon fault into the repository block.

Analyses will be performed to estimate the total probability for experiencing significant fault movement anywhere in the underground facilities during the preclosure period. These estimates will consider possible effects from known and unknown faults in the area.

Consideration of vibratory ground motion

Repository facilities will be designed and constructed to withstand the effects of vibratory ground motions. Conventional standards will be used for most facilities; however, more conservative design measures will be used for those facilities considered important to safety, specifically the waste handling facilities. Thus, the requirement is to determine ground-motion characteristics for consideration in the design of facilities important to safety.

Performance and design requirements for characterizing the potential for vibratory ground motion are presented in Table 8.3.1.17-5(a). The design-basis ground motions are to be characterized for frequencies significant to facilities important to safety such that there is less than a 10-percent chance for being exceeded during 100 yr. Accordingly, the design-basis motions are to have an annual exceedance probability less than 10^{-3} /yr, which translates to an average recurrence period greater than 1,000 yr. This goal appears to be consistent with the level of conservatism used for other facilities with important considerations for safety.

An important precedent is provided by nuclear power plants where annual probabilities for exceeding the design-basis motions have been found to be on the order of 10^{-3} /yr to 10^{-4} /yr for several operating plants (Reiter and Jackson, 1983).

Based on current understanding of design needs, the approach that has been developed here uses both deterministic and probabilistic methods to their best advantage. The role of the deterministic approach is primary. It provides the level of detail needed by design engineers in the characterization of ground motions. The probabilistic approach provides a logical, structured procedure for integrating the range of possible earthquakes that contribute to the ground-motion hazard at the site. This capability will be used to guide, test, and substantiate the deterministic analyses. Sensitivity analyses will be performed using probabilistic methods to evaluate the effect of uncertainties on the ground motion potential. Results from these

CONSULTATION DRAFT

analyses will be used to help focus field investigations toward refinement of those seismic parameters that most strongly influence ground-motion potential at the site. In addition, probabilistic methods will be used as needed to provide input for the assessment of risk of accidental release of radio-nuclides.

Vibratory ground motions at the site can result from natural earthquakes on local and regional faults, and from underground nuclear explosions (UNEs) detonated at the Nevada Test Site. Much of the discussion to follow on the current approach for developing design-basis ground motions focuses on issues of natural earthquakes. The deterministic methods that will be applied for analyzing ground motions from UNEs parallel, in most respects, those described for dealing with natural earthquakes.

The ground-motion potential near Yucca Mountain differs considerably from that in much of California where a major portion of the relative plate motions are being accommodated, and also from that in the true plate interior regions of the midwestern and eastern U.S. There is an abundance of faults local to the site, but their rate of movement appears to be low. On the basis of fault data and historical seismicity, severe earthquakes are probably not as common in the vicinity of Yucca Mountain as in the more active regions surrounding much of the Great Basin.

To adequately characterize the local earthquake hazards, some of the terminology and procedures used in characterizing potential ground motions elsewhere are being refined to meet the needs of a waste repository. For example, in the determination of design ground motions for some types of critical facilities, professional practice has been to define maximum earthquake magnitudes with the understanding that a larger earthquake magnitude may be possible, although very unlikely. This practice is being made more explicit for characterizing this site. In particular, 10,000-year cumulative slip earthquakes will be identified for consideration in repository design. A 10,000-year cumulative slip earthquake is defined here to be an earthquake that, occurring every 10,000 years, would produce the observed or estimated average Quaternary slip rate on a fault. A detailed discussion of the concept is provided in the description of activity 8.3.1.17.3.1.2.

An important advantage of this refinement is that a 10,000-year cumulative slip earthquake magnitude, being associated with a particular recurrence interval, can be determined with greater confidence than a true maximum magnitude. Because large earthquakes occur infrequently, few observational data are available for calibrating the maximum seismogenic potential of individual faults. This is particularly true for faults of the type found in the southern Great Basin, where recurrence intervals for large earthquakes appear to range from about 10,000 to 100,000 yr (see Section 1.4.2). Therefore, conventional methods for determining maximum earthquake magnitudes from the physical characteristics of local faults appear to be subject to larger uncertainties than for the more active faults associated with plate motions. Use of slip-rate data (to constrain recurrence times) in conjunction with more conventional fault data provides added assurance that adequately conservative assessments of the local seismogenic potential will be accomplished.

The planned procedure for characterizing potential ground motions at the site is as follows: First, the active surface faults and potentially active

CONSULTATION DRAFT

fracture zones at depth that could produce locally severe ground motions will be identified. Second, 10,000-year cumulative slip earthquakes, as defined previously, will be determined. Third, controlling earthquakes will be identified as those 10,000-year cumulative slip earthquakes that produce the most severe motions at the site. The resulting vibratory ground motions will then be characterized by a suite of representative time histories and response spectra that have been scaled to the magnitudes and distances of the controlling earthquakes and modified, as needed, to account for the effects of local site geology. A suite of representative strong-motion records may be needed for more than one controlling earthquake, to cover the possibility that different source regions could control ground motions at the site in different frequency bands.

To characterize potential ground motions from UNEs, a similar procedure will be followed. First, the possible locations and upper limits on the yields of future UNEs at the NTS will be identified. With this information, the maximum UNEs with respect to generating ground motions at the site will be determined. If the resulting site ground-motion estimates are comparable to those for the controlling earthquake sources, the UNE ground motions will be further characterized by a suite of representative time histories and spectra.

Preliminary evaluations of potential earthquake sources in the vicinity of Yucca Mountain have identified several local faults as long as 20 km or more. If, as is currently planned, the waste handling facilities were located on Midway Valley, the controlling source would appear to be the north-south trending Paintbrush Canyon fault, which bounds Midway Valley on the east. The closest approach of the Paintbrush Canyon fault to the proposed site of the waste handling facilities is about one kilometer. This fault may be capable of producing a moderate earthquake (M about 6.5) with a recurrence interval greater than ten thousand years. Site characterization will determine which fault or faults control the ground motion at frequencies within the range of engineering interest.

Because the annual probability for the controlling earthquake is expected to be low (less than about 10^{-4} , assuming the Paintbrush Canyon fault is controlling), and because the components required to contain radioactive materials within the waste-handling building can be expected to survive ground motions more severe than those used for design, ample conservatism can be achieved by using the most probable motions from the 10,000-year cumulative slip earthquake(s) on the controlling earthquake source(s) as the basis for seismic design. Probabilistic calculations will be performed to test and verify that the resulting ground motions exceed the thousand-year estimate from the combined hazard from natural earthquakes and underground nuclear explosions.

Interrelationships of preclosure tectonics investigations

The interrelationships of the investigations in the preclosure tectonics site characterization program are shown in Figure 8.3.1.17-1. There are three analysis and assessment investigations that correspond to potentially disruptive volcanic activity, fault displacements, and vibratory ground motion, respectively. These three investigations are designed to provide the required characterization parameters. A fourth investigation comprises a

number of data collection and synthesis activities that support one or more of the three analysis and assessment investigations.

The schedule information provided for investigations in this section includes the sequencing, interrelationships, and relative durations of the studies in the investigation. Specific durations and start/finish dates for the studies are being developed as part of ongoing planning efforts and will be provided in the SCP at the time of issuance and revised as appropriate in subsequent semiannual progress reports.

8.3.1.17.1 Investigation: Studies to provide required information on volcanic activity that could affect repository design c- performance

Technical basis for obtaining the information

Link to technical data chapters and applicable support documents

The following sections provide a technical summary of existing data relevant to this investigation:

<u>SCP section</u>	<u>Subject</u>
1.3.2.1	Volcanic history
1.5.1	Volcanism
1.8.1.3.1	Significant results
1.8.1.3.2	Discussion of significant results
1.8.1.5.1	Significant results

Parameters

This investigation will provide the following characterization parameters related to potential ash fall at the site from distal silicic volcanic centers (see Tables 8.3.1.17-1(a), -1(b), -2(a), and -2(b)):

1. Probability of ash fall at the site as a function of ash-fall thickness.
2. Expected ash-fall thickness at the site in a 1,000-yr period.
3. Potential ash-fall particle densities and size distributions.

Investigation 8.3.1.8.1 (direct releases resulting from volcanic activity--postclosure) will provide the following characterization parameters related to the potential for a basaltic volcanic eruption at the site (Table 8.3.1.8-1):

1. Location and timing of volcanic events near the site.
2. Evaluation of structural controls on the occurrence of basaltic .
3. Presence of magma bodies in the vicinity of the site.
4. Effects of Strombolian eruptions.
5. Effects of hydrovolcanic eruptions.

CONSULTATION DRAFT

Purpose and objectives of the investigation

Two types of volcanic hazards that could credibly affect preclosure repository performance will be characterized: (1) ash fall from distal silicic volcanic centers in the western Great Basin and (2) a basaltic volcanic eruption at the site. Ash fall is being addressed under preclosure tectonics because of its potential impact on surface and subsurface ventilation systems (dust filters). However, the study of basaltic volcanism in the site region will be conducted under the postclosure tectonics program (Section 8.3.1.8), because the probability of basaltic volcanism at the site is greater over the longer postclosure time frame. The probability of a basaltic volcanic eruption at the site during the preclosure period will be estimated there. No studies are planned of potential silicic volcanism in the site region because a silicic volcanic eruption at the site is not considered a credible event (Section 1.5.1).

The characterization parameters related to ash fall are being provided so that the filtration systems of the surface-facility and mining ventilation systems can be designed to accommodate potential ash falls at the site. The characterization parameters related to basaltic volcanism are intended to provide assurance that the probability of a volcanic eruption at the site is acceptably low (i.e., as interpreted here, less than one chance in 10,000 in 100 yr).

Technical rationale for the investigation

A logic diagram for the investigation of preclosure volcanic activity is presented in Figure 8.3.1.17-3. The potential for ash falls at the site from distal silicic volcanic centers will be addressed in Study 8.3.1.17.1.1. Since much work has already been published on silicic volcanism in the region, data will be compiled primarily through a literature survey in Activity 8.3.1.17.1.1.1. For the western Great Basin, locations of silicic volcanic center, rates and volumes of past eruptions, tephra dispersal patterns for past eruptions, and tephra particle-size, distributions in past eruptions will be compiled. The ash-fall potential at the site will be assessed by assuming that silicic volcanic eruptions are a stationary random process and, hence, that observed Quaternary rates and distributions can be projected into the future.

The potential ash-fall thickness at the site will be assessed in Activity 8.3.1.17.1.1.2 and expressed in terms of the characterization parameters listed in Tables 8.3.1.17-1(a), -1(b), -2(a), and -2(b). A probability-versus-thickness function will be estimated, and a particular ash-fall thickness that has less than one chance in 10 of occurring in 100 yr (i.e., a greater-than-1,000-yr ash fall) will be estimated for consideration in the design of mining and surface ventilation systems. The potential particle density and particle-size distribution of an ash fall at the site will be assessed in Activity 8.3.1.17.1.1.3.

The potential for a basaltic volcanic eruption to directly disrupt the repository is being addressed in Investigation 8.3.1.8.1, under postclosure tectonics. The probability of a basaltic eruption penetrating the repository will be estimated in Study 8.3.1.8.1.1, and the potential geologic effects of

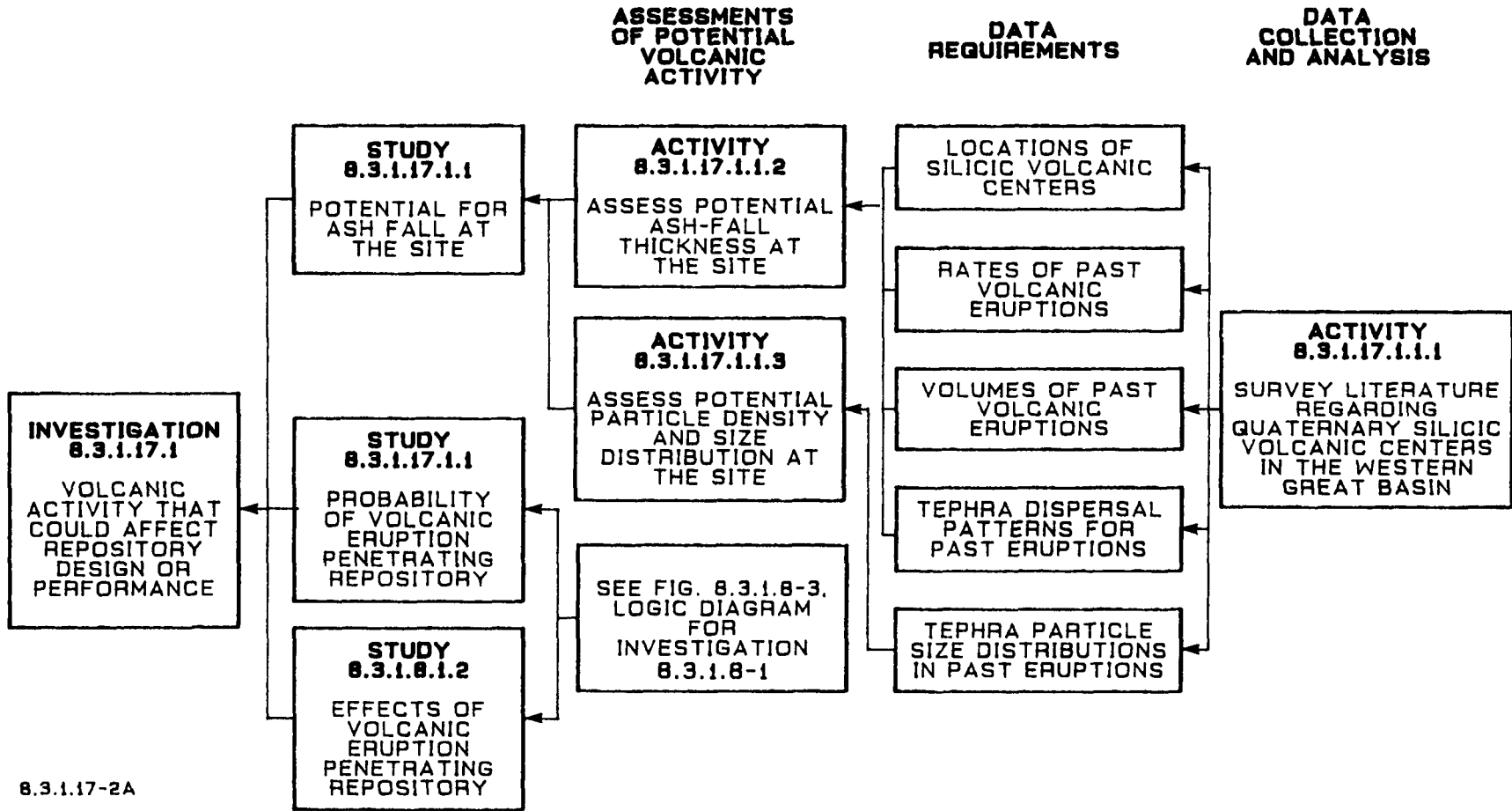

8.3.1.17-2A

Figure 8.3.1.17-3. Logic diagram for Investigation 8.3.1.17.1 (preclosure volcanic activity)

CONSULTATION DRAFT

such an eruption on the site will be assessed in Study 8.3.1.8.1.2. The supporting activities and data requirements for these two studies are indicated in the logic diagram for Investigation 8.3.1.8.1 (Figure 8.3.1.8-3).

8.3.1.17.1.1 Study: Potential for ash fall at the site

Three activities are included in this study.

8.3.1.17.1.1.1 Activity: Survey literature regarding Quaternary silicic volcanic centers in the western Great Basin

Objectives

The objective of this activity is to compile information on Quaternary silicic volcanism in the western Great Basin, the reoccurrence of which might produce an ash fall at the site.

Parameters

Information to be compiled includes locations of silicic volcanic centers, rates of past eruptions, volumes of past eruptions, tephra dispersal patterns in past eruptions, and tephra particle size distributions in past eruptions.

Description

Required data will be gathered from the geological literature. Volcanic fields of interest include the Coso field, the Big Pine field, Long Valley caldera, and the Mono-Inyo Dome chain.

Methods and technical procedures

No original work will be required to address this activity. Published geologic literature will be used based on NNWSI Project SOP-03-03 (Acceptance of data or data interpretation not developed under the NNWSI Project Quality Assurance (QA) Plan).

8.3.1.17.1.1.2 Activity: Assess potential ash-fall thickness at the site

Objectives

The objective of this activity is to produce an approximate probability-versus-thickness function for potential ash falls at the site and to estimate a particular ash-fall thickness that has less than one chance in ten of occurring in 100 yr. These hazard estimates will be considered in the design of filters in the mining and surface-facility ventilation systems.

Parameters

The parameters required for this assessment activity include the following:

1. Locations of Quaternary silicic volcanic centers in the western Great Basin.
2. Rates, volumes, and tephra dispersal patterns of Quaternary silicic volcanic eruptions in the western Great Basin.

Description

The ash-fall hazard estimates will be produced by extrapolating the observed Quaternary rates, volumes, and tephra dispersal patterns of silicic volcanic eruptions in the western Great Basin into the future and by calculating the probabilities of experiencing different ash-fall thicknesses at the site, considering the site location relative to the silicic volcanic centers. These estimates will be based on the information compiled in Activity 8.3.1.17.1.1.1.

Methods and technical procedures

The methods and technical procedures for this activity are to be developed.

8.3.1.17.1.1.3 Activity: Assess potential particle density and size distribution of ash fall at the site

Objectives

The objective of this activity is to estimate the potential particle densities and particle-size distributions of ash falls at the site for consideration in the design of filters in the mining- and surface-facility ventilation systems.

Parameters

The parameters required for this assessment activity are historical ash-fall particle densities from silicic volcanic eruptions and particle-size distributions in ash beds corresponding to Quaternary silicic volcanic eruptions in the western Great Basin.

Description

Potential ash-fall particle densities at the site will be assumed to be comparable to particle densities that have been observed historically in ash falls from silicic volcanic eruptions, at distances similar to those between the site and the silicic volcanic centers in the western Great Basin. Potential particle size distributions at the site will be estimated on the basis of observed size distributions in ash beds that correspond to Quaternary silicic volcanic eruptions in the western Great Basin and that are at

CONSULTATION DRAFT

distances comparable to that of the site from the volcanic centers. The analyses will be based on information compiled in Activity 8.3.1.17.1.1.1.

Methods and technical procedures

The methods and technical procedures for this activity are to be developed.

8.3.1.17.1.2 Application of results

The information to be obtained in Study 8.3.1.17.1.1 is required for consideration in the design of filters in both the mining- and the surface-facility ventilation systems. As such, it is called for by Information Needs 4.4.8 and 4.4.9 (identification of technologies for surface-facility and underground-facility construction, operation, closure, and decommissioning, respectively).

8.3.1.17.1.3 Schedule and milestones

This investigation on volcanic activity contains one study: 8.3.1.17.1.1 (potential for ash fall at the site), which is expected to be initiated within the first year of site characterization. In the figure that follows, the schedule information for this study is presented in the form of a timeline. The timeline extends from implementation of the approved study plan to the issuance of the final products associated with the study. Summary schedule and milestone information for this investigation can be found in Section 8.5.1.1.

The activities of this entire investigation are planned to progress in parallel with performance and design activities in an iterative fashion. Information from this study will be considered in both advanced conceptual and license application designs of the surface and underground ventilation systems. This information will also be used for resolving issues related to worker safety (Sections 8.3.5.4 and 8.3.5.5).

This study is not seriously constrained by other program elements because it uses data compiled from a literature search.

The study number and title corresponding to the timeline are shown on the left of the following figure. The point shown on the timeline represents a major event or important milestone associated with the study. A solid line represents study duration.

CONSULTATION DRAFT

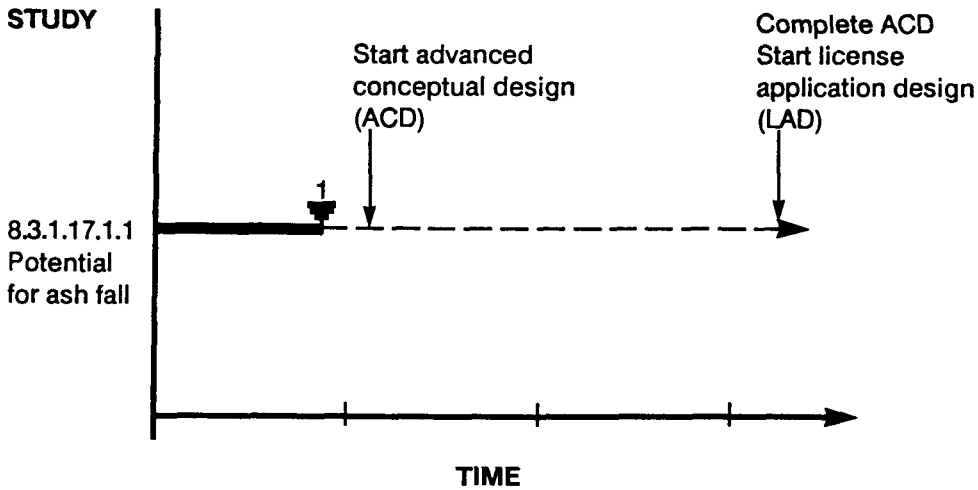

8311714-VA

The points on the timeline are described in the following table:

<u>Point number</u>	<u>Description</u>
1	Milestone Q144. Report on volcanic ash-fall potential at the site. This information will be considered in both the advanced conceptual and license application designs of the surface and underground ventilation systems.

8.3.1.17.2 Investigation: Studies to provide required information on fault displacement that could affect repository design or performance

Technical basis for obtaining the information

Link to the technical data chapters and applicable support documents

The sections of the SCP data chapters that summarize existing data relevant to this investigation are as follows:

<u>SCP section</u>	<u>Subject</u>
6.1.4	Surface structures, systems, and components considered important to safety
1.3	Structural geology and tectonics
1.5	Long-term stability with respect to tectonics and geologic processes

Parameters

This investigation will compile or develop the following characterization parameters related to the potential for fault displacement beneath

CONSULTATION DRAFT

surface facilities considered important to safety (see Tables 8.3.1.17-3(a) and -3(b)):

1. Identification and characterization of potentially significant Quaternary faults within 5 km of facilities important to safety (FITS).
2. Identification and characterization of faults within 100 m of FITS that have apparent Quaternary slip rates > 0.001 mm/yr or that measurably offset materials that are less than 100,000 yr old.
3. Estimated total probability of exceeding 5 cm displacement beneath FITS, considering known faults, possibly concealed faults, and tectonic interrelationships among local faults.

The following characterization parameters related to the potential for underground fault displacement in areas of emplaced waste will also be compiled or developed in this investigation (see Tables 8.3.1.17-4(a) and -4(b)):

1. Surface locations of faults in the repository block that offset Quaternary materials by more than 1 m or Tertiary rocks by more than 100 m.
2. Surface and subsurface locations of any faults that intersect prospective underground facilities and that have average Quaternary slip rates greater than 0.005 mm/yr.
3. Estimated total probability of exceeding 7 cm displacement on any fault in the the area of emplaced waste, considering known and possibly concealed faults and the tectonic interrelationships among local faults.

Purpose and objectives of investigation

The siting objective vis-a-vis potential surface faulting is to avoid fault displacement in excess of a few inches beneath the structural foundations of surface facilities considered important to safety. The corresponding goal of this investigation, expressed in Table 8.3.1.17-3(a), is to demonstrate, with a high degree of confidence, that there is less than a one percent chance of exceeding 5 cm of fault displacement beneath surface facilities important to safety during the preclosure period (approx. 100 yr). (A discussion of the reasonableness of this goal is provided in the overview of this section.)

The primary concern regarding faulting in the underground facilities during preclosure is that waste packages might be sheared or become jammed in their waste-emplacement boreholes, making retrieval more difficult and time consuming than it otherwise would be. The corresponding goal (see Tables 8.3.1.17-4(a) and -4(b)) is to demonstrate with a moderate degree of confidence that there is less than a ten percent chance of exceeding 7 cm of fault displacement in areas of emplaced waste in 100 yr, considering all faults that may intersect these areas. (A displacement of 7 cm is the minimum value at which the sides of a faulted waste-emplacement borehole

CONSULTATION DRAFT

would be expected to contact a waste package.) No single fault with the potential to exceed this goal is currently thought to exist, but if such a fault is identified, an attempt will be made to determine its location underground for consideration in the positioning of waste-emplacment boreholes.

Technical rationale for investigation

A logic diagram for the investigation of preclosure fault displacement is presented in Figure 8.3.1.17-4.

The potential for surface faulting at locations of surface facilities important to safety (FITS) will be assessed in Activity 8.3.1.17.2.1.1 and expressed in terms of the characterization parameters listed in Table 8.3.1.17-3(b). The most important information pertaining to potential fault displacement beneath FITS is expected to come from detailed geologic mapping of alluvial deposits in Midway Valley and from exploratory trenching in the immediate vicinity of prospective surface FITS. Exploratory trenches are expected to intersect surficial units that are at least 100,000 yr old. Any faults that measurably displace units less than 100,000 yr old and any faults found to have Quaternary slip rates exceeding 0.001 mm/yr (10 cm/100,000 yr) will be identified.

Because significant faulting is sometimes accompanied by sympathetic displacements in adjacent areas, information on fault-zone widths and recurrence of movement on Quaternary faults within 5 km of surface FITS will also be analyzed. Of particular interest for any such fault will be any evidence of concealed extensions that may trend toward Midway Valley and the sites of prospective FITS.

The probability of exceeding 5 cm displacement on any fault beneath prospective surface FITS will be estimated in Activity 8.3.1.17.2.2.1, considering, in addition to the information cited previously, the tectonic interrelationships between local faults, the possible existence of concealed faults, and the potential for the surface trace of a fault to change locations from event to event. The goal is to locate the surface FITS in an area where there is less than a one percent chance of exceeding 5 cm of displacement in 100 yr, with high confidence. Any site without faults having apparent Quaternary slip rates greater than 0.001 mm/yr and faults that measurably offset materials less than 100,00 yr old is expected to meet this goal conservatively, even if an undetected component of strike-slip motion exists that is as large as the measured dip-slip components.

The potential for displacement on faults that intersect underground facilities will be assessed in Activity 8.3.1.17.2.1.2; the corresponding design parameters and characterization parameters are listed in Tables 8.3.1.17-4(a) and -4(b).

To meet the design-parameter goal of identifying and characterizing significant late Quaternary faults in the repository block, the locations of faults with more than 1-m offset of Quaternary materials, or with more than 100-m offset of Tertiary rocks, will be determined. Current data provide low-to-moderate confidence that only two such faults exist, namely the Bow

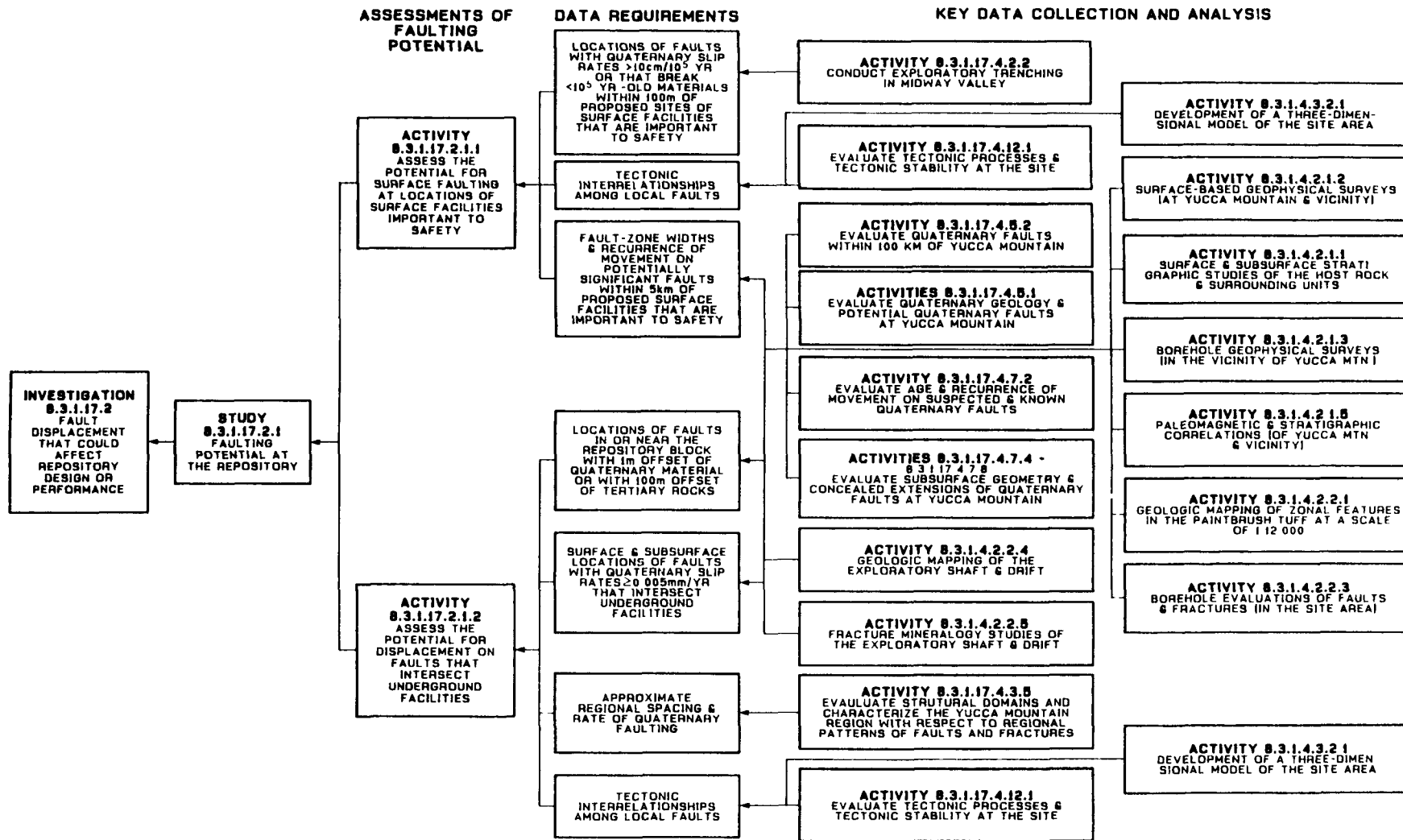

Figure 8.3.1.17-4. Logic diagram for the Investigation 8.3.1.17.2 (preclosure fault displacement)

CONSULTATION DRAFT

Ridge and Solitario Canyon faults. Further work will be performed in Study 8.3.1.17.4.6 (Quaternary faulting within the site area) to provide added confidence that there are no additional significant late-Quaternary faults in the repository block.

A second design-parameter goal is to identify, characterize and locate within the waste-emplacement area any fault with more than a one percent chance of producing displacement greater than 7 cm during the preclosure period. Faults with slip rates less than 0.005 mm/yr would be very unlikely to exceed this threshold (see overview discussion of the preclosure tectonics site program in this section), and current data indicate that, with moderate confidence, no faults with Quaternary slip rates greater than 0.005 mm/yr exist in the repository block. Further work will be performed in Study 8.3.1.17.4.7 to achieve a moderate-to-high level of confidence in this finding.

Information on particular Quaternary faults in the repository block, data on the regional spacing and rate of movement of Quaternary faults, and interpretations of tectonic interrelationships among local faults will be synthesized in Activity 8.3.1.17.2.1.2 to estimate a total probability of exceeding 7 cm displacement on faults that intersect areas of emplaced waste. This work is expected to corroborate the current assessment that, with moderate confidence, the total probability of exceeding 7 cm displacement in 100 yr on any fault in the area proposed for waste emplacement is less than one percent.

8.3.1.17.2.1 Study: Faulting potential at the repository

This study includes two activities.

8.3.1.17.2.1.1 Activity: Assess the potential for surface faulting at prospective sites of surface facilities important to safety

Objectives

The objective of this activity is to assess the stability of the site surface with respect to fault displacement, at locations proposed for facilities important to safety (FITS). Particular objectives are to develop the characterization parameters listed in Table 8.3.1.17-3(b) and discussed previously with the indicated levels of confidence.

Parameters

The data required for this synthesis activity include the following:

1. Locations of faults within 100 m of locations proposed for FITS that have apparent Quaternary slip rates greater than 0.001 mm/yr or that measurably offset materials less than 100,000 yr old.

CONSULTATION DRAFT

2. Fault-zone widths and recurrence of movement on potentially significant faults within 5 km of locations proposed for FITS.
3. Tectonic interrelationships among local faults.

The key parameter to be produced by this activity is an estimate of the total probability of exceeding 5 cm fault displacement at locations proposed for FITS.

Description

This is a synthesis and assessment activity that draws on data collected elsewhere, mostly from the Quaternary faulting studies in Investigation 8.3.1.17.4 and the studies of stratigraphy and structure in Investigation 8.3.1.4.2. The data sets that will be synthesized, the general approach to the synthesis, and the required assessments are described previously in the discussion of the technical rationale for this investigation and in the overview of the preclosure tectonics site program. A few more details on the synthesis of the faulting potential are provided here.

The assessment of the probability of fault displacement beneath FITS may benefit from a consideration of the fractal characteristics of local fault systems and of the mechanical interactions between local faults.

Surface FITS will be sited where there is no evidence of substantial Quaternary faulting, but concealed faults and the possibility of the surface trace of a fault appearing at a new location cannot be ruled out and will be evaluated. Since fault systems tend to have self-similar geometries (i.e., to have similar degrees of branching and complexity over a wide range of map scales) an analysis of the fractal characteristics of local fault systems may be useful for estimating the spatial density and lengths of subsidiary faults that may lie concealed in the vicinity of FITS.

The reasonableness of postulated tectonic interrelationships among local faults can be checked to some extent by analyzing the stresses generated by the displacements that are assumed to be occurring; the local stress field generated by assumed slip on one fault should not act to oppose the slip that is assumed for other faults. If slip directions and magnitudes are constrained by geologic data, stress analyses may indicate areas of stress concentration that may be accommodated by concealed faults.

Methods and technical procedures

The methods and technical procedures for Activity 8.3.1.17.2.1.1 are given in the following table.

CONSULTATION DRAFT

Method	Technical procedure		
	Number	Title	Date
Analysis of data to calculate fault- displacement proba- bilities at surface locations	TBD ^a	TBD	TBD

^aTBD = to be determined.

8.3.1.17.2.1.2 Activity: Assess the potential for displacement on faults that intersect underground facilities

Objectives

The objective of this activity is to assess the potential for displacement on faults that intersect underground facilities. Particular objectives are to develop the characterization parameters listed in Table 8.3.1.17-4(b) with the indicated levels of confidence.

Parameters

Data required for this synthesis activity include the following:

1. Locations of faults in the repository block that offset Quaternary materials by more than 1 m or Tertiary rocks by more than 100 m.
2. Surface and subsurface locations of faults with Quaternary slip rates greater than 0.005 mm/yr that intersect areas proposed for waste emplacement.
3. Approximate regional spacing and rate of Quaternary faults.
4. Tectonic interrelationships among local faults.

The key parameter to be provided by this activity is an estimate of the total probability of exceeding 7 cm displacement in 100 yr on any fault that intersects areas proposed for waste emplacement.

Description

This is a synthesis and assessment activity that draws on data collected by other activities, as indicated in Figure 8.3.1.17-4. The data sets that will be synthesized, the general approach to the synthesis, and the required assessments are described previously in the discussion of the technical

CONSULTATION DRAFT

rationale for this investigation and in the overview of the preclosure tectonics site program. A few observations on the general approach are presented here.

The assessment of faulting potential at depth will be predominantly inferential, because the recency and amount of movement on a fault encountered at depth while mining is nearly impossible to determine from the limited exposure in the mine. Also, the subsurface projections of faults that are expressed at the surface are often poorly constrained by surface geophysical evidence. In the unexpected instance that a fault is found that may project through proposed areas of emplaced waste and that has surface evidence of a slip rate exceeding 0.005 mm/yr, the fault will be located (perhaps by drilling and coring) in the underground.

The inference of faulting potential will be based in part on the average spacing of Quaternary faults that is estimated for the structural domain that encompasses the site. (A structural domain is a crustal block within which faulting of a given genetic type generally occurs with uniform characteristics.) Key information for defining the structural domain of the site will come from Activity 8.3.1.17.4.3.5. The assessment of faulting potential will also consider estimates of slip rates on Quaternary faults in the site area (from Activity 8.3.1.17.4.6.2), the fractal geometry of local fault systems (see description of Activity 8.3.1.17.2.1.1), interpreted tectonic (mechanistic) interrelationships among local faults, and models for the accommodation of regional strain by local faults.

Methods and technical procedures

The methods and technical procedures for activity 8.3.1.17.2.1.2 are given in the following table.

Method	Technical procedure		
	Number	Title	Date
Analysis of data to calculate fault displacement probabilities at surface locations	TBD ^a	TBD	TBD

^aTBD = to be determined.

8.3.1.17.2.2 Application of results

Information on potential fault displacement will be used as follows:

1. In the development and analyses of the repository design (Issue 4.4, preclosure design and technical feasibility, Section 8.3.2.5).

CONSULTATION DRAFT

2. In the determination of credible accidents that are applicable to the repository (Issue 2.3, accidental radiological releases, Section 8.3.5.5).
3. In the determination that waste can be accessed and removed from the emplacement boreholes throughout the retrievability period for normal and off-normal conditions (Issue 2.4, waste retrievability, Section 8.3.5.2).
4. In the identification of normal and accident conditions, including disruptive events (Issue 2.7, preclosure radiological design requirements, Section 8.3.2.3).

8.3.1.17.2.3 Schedule and milestones

This investigation, addressing fault displacement, contains one study consisting of two activities: 8.3.1.17.2.1.1 (assess potential for surface faulting at locations of surface facilities) and 8.3.1.17.2.1.2 (assess potential for displacement on faults that intersect underground facilities). In the figure that follows, the schedule information for these activities is presented in the form of timelines. The timelines extend from implementation of the approved study plans to the issuance of the final products associated with the study. Summary schedule and milestone information for this investigation can be found in Section 8.5.1.1.

The study on faulting potential at the site (8.3.1.17.2.1) is expected to begin within the first year of site characterization. The activities are planned to progress in parallel with performance and design activities in an iterative fashion. The results of this study will be used toward the resolution Issues 1.1 (total system performance), 1.8 (NRC siting criteria), and 1.10 (waste package characteristics) and to support repository design. Information from this study will be considered in both advanced conceptual and license application designs. This information will also be used in the resolution of issues related to preclosure safety.

This study is constrained by the collection and analysis of preclosure tectonics data, specifically Studies 8.3.1.17.4.2, 8.3.1.17.4.3, and 8.3.1.17.4.6 and Activities 8.3.1.17.4.12.1 and 8.3.1.17.4.3.5.

The study number and title corresponding to the timelines are shown on the left of the following figure. Activity numbers are indicated on the appropriate timeline. The points shown on the timelines represent major events or important milestones associated with the study. Solid lines represent study durations. The data input and output at the interfaces are shown by circles.

CONSULTATION DRAFT

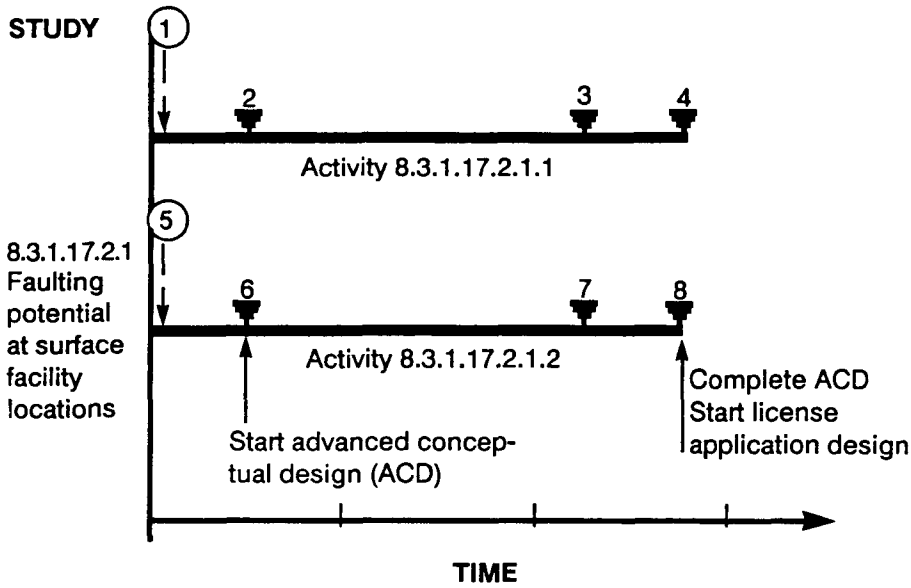

8311724-VA

The points on the timeline and the data input and output at the interfaces are described in the following table:

<u>Point number</u>	<u>Description</u>
1	Initiation of activity requires at least preliminary results from trenching in Midway Valley (Study 8.3.1.17.4.2). The activity also requires preliminary interpretation of tectonic interrelationships between local faults (from Study 8.3.1.17.4.12) and preliminary information on fault-zone widths and recurrence of movement on potentially significant faults within 5 km of proposed sites for surface facilities that are potentially important to safety (primarily from Study 8.3.1.17.4.6).
2	Preliminary report on the assessment of the potential for surface faulting; input to advanced conceptual design.
3	Activity resumes, utilizing final results developed in Studies 8.3.1.17.4.2, 8.3.1.17.4.12, and 8.3.1.17.4.6, as described under item 1.
4	Milestone Q147. Final report on the assessment of the potential for faulting at the sites of prospective surface facilities.
5	Initiation of activity requires preliminary identification of faults in or near the repository block with 1 m offset of Quaternary materials, 100 m offset of Tertiary rocks, or Quaternary slip rates ≥ 0.005 mm/yr (primarily from Study 8.3.1.17.4.6); preliminary information on the regional spacing and rate of Quaternary faulting (from Study 8.3.1.17.4.3); and tectonic relationships between local faults (Study 8.3.1.17.4.12).

CONSULTATION DRAFT

<u>Point number</u>	<u>Description</u>
6	Preliminary report on the assessment of the potential for displacement on faults that intersect underground facilities; input to advanced conceptual design.
7	Resumption of activity requires final results from Studies 8.3.1.17.4.6, 8.3.1.17.4.3, and 8.3.1.17.4.12, as described under item 5.
8	Milestone Q148. Final report on the assessment of the potential for displacement on faults that intersect underground facilities; input to license application design.

8.3.1.17.3 Investigation: Studies to provide required information on vibratory ground motion that could affect repository design or performance

Technical basis for obtaining the information need

Link to the technical data chapters and applicable support documents

Sections 1.3, 1.4, and 1.5 of the SCP data chapters provide a technical summary of existing data relevant to this investigation.

Parameters

This investigation will provide the following characterization parameters related to potential vibratory ground motion at the site from natural and man-made seismic sources (see Tables 8.3.1.17-5(a), -5(b), -6(a), and -6(b)):

1. Identification of potential earthquake sources in the controlled area.
2. Identification of earthquake sources within 100 km of the site that could be relevant to the site (i.e., that could conceivably control the design-basis ground motions at the site in any frequency band of engineering significance).
3. Magnitudes of 10,000-year cumulative slip* earthquakes on local earthquake sources.

*10,000-year cumulative earthquakes are defined here to be earthquakes that, occurring every 10,000 years, would produce the observed or estimated average Quaternary slip rate on a fault; see discussion in description of Activity 8.3.1.17.3.1.2.

CONSULTATION DRAFT

4. Magnitudes of 10,000-year cumulative slip* earthquakes on regional earthquake sources.
5. Maximum potential yields of future underground nuclear explosions (UNEs) at the NTS.
6. Closest distance between the site and potential future UNEs at NTS.
7. Ground-motion models/attenuation relationships for the site region (i.e., mathematical models for predicting the values of ground-motion parameters as a function of the distance from and the strength of the earthquake or UNE source).
8. Spectral amplification functions that represent the effects of local site geology on surface seismic motions and the effects of depth on underground seismic motions.
9. Identification of controlling seismic events--those 10,000-year cumulative slip earthquakes and/or potential largest and closest UNEs that would generate the most severe ground motions at the site in any frequency band of engineering significance, taking into account a local-geologic or depth effects on the ground motion.
10. Time histories and response spectra that are representative of potential ground motion at the site from the controlling seismic event(s).
11. Magnitude-recurrence relationships for all regional earthquake sources that could contribute to the earthquake hazard at the site.
12. Probabilities of exceeding selected ground-motion parameters at the site, developed through probabilistic seismic hazard analysis.

Purpose and objectives of the investigation

The purposes of this investigation are to (1) develop a seismic-design basis for repository facilities that are important to safety, and (2) provide other information that will facilitate the assessment of the adequacy of the seismic-design basis and the identification of credible accidents that might be initiated by seismic events and lead to release of radioactive materials. The seismic-design basis will account for both the potential occurrence of earthquakes on nearby faults and potential future underground nuclear explosions at the Nevada Test Site.

*10,000-year cumulative earthquakes are defined here to be earthquakes that, occurring every 10,000 years, would produce the observed or estimated average Quaternary slip rate on a fault; see discussion in description of Activity 8.3.1.17.3.1.2.

CONSULTATION DRAFT

The planned methodology for developing the seismic-design basis is, as is discussed in detail below, intended to result in design levels such that the probability of the design level being exceeded is comparable to typical exceedance probabilities for the seismic-design bases of operating nuclear power plants in the United States (i.e., annual probabilities of exceedance on the order of 1×10^{-3} to 1×10^{-4}).

Although this investigation is motivated by the need to develop a seismic-design basis and other information related to the design of facilities important to safety (FITS), the resulting design-basis ground-motion descriptions also may be considered in the design of other repository facilities. (Presently, only the shipping cask and certain components of the waste-handling facilities are considered potentially important to safety (Laub and Jardine, 1987). Current plans call for the FITS seismic-design basis to be considered also in the design of underground facilities (Information Need 4.4.1, site and performance assessment information needed for design, Section 8.3.2.5.1).

The approach that is currently considered appropriate for developing a seismic design basis is deterministic, meaning that the design-basis ground-motion description will correspond to the postulated occurrence of a discrete seismic event or events (e.g., the occurrence of an earthquake of specified magnitude on a particular fault). This type of approach parallels that used to develop the seismic design bases of all nuclear power plants in the United States. In addition, probabilistic estimates of the seismic hazard at the site will be developed that integrate individual contributions to the site's ground-motion potential from earthquake sources at different distances and with different earthquake recurrence characteristics. The probabilistic seismic hazard estimates will be used to evaluate and constrain required technical judgments in the deterministic approach, evaluate the adequacy of the deterministic results, and help identify and focus efforts to refine those parameters that are most important for the deterministic calculations. The probabilistic hazard estimates will also provide input needed to determine credible accidents that are applicable to the repository (Information Need 2.3.1, Section 8.3.5.5.1).

In summary, probabilistic seismic hazard estimates will be an important adjunct to the deterministic estimates that will be developed for consideration in the seismic design of FITS. A discussion of the reasons for using deterministic and probabilistic methodologies in this fashion is given in the Overview section for this investigation.

Technical rationale for investigation

10,000-year cumulative slip earthquakes are defined here to be earthquakes that, occurring every 10,000 years, would produce the observed or estimated average Quaternary slip rate on a fault (see detailed discussion in description of Activity 8.3.1.17.3.1.2). Controlling seismic events are those exceptional earthquakes and/or potential largest and closest UNEs that would generate the most severe ground motions at the site in any frequency band of engineering significance. The seismic design basis for FITS will be suites of ground-motion time histories and corresponding response spectra that are representative of the controlling seismic events.

CONSULTATION DRAFT

A logic diagram for this investigation is presented in Figure 8.3.1.17-5.

Study 8.3.1.17.3.1 will identify and characterize earthquake sources that could potentially be relevant to a deterministic seismic hazard analysis of the site, i.e., sources that could conceivably produce exceptional earthquakes that would control the seismic-design basis in any frequency band of engineering significance. Characterization of earthquake sources for the deterministic hazard assessment will include a determination of each source's location, orientation, depth, likely style of faulting, and an evaluation of the 10,000-year cumulative slip earthquake magnitude. Here, and elsewhere, uncertainty in the determination of input parameters will be estimated so that the sensitivity of the final results to key assumptions can be estimated.

The identification and characterization of relevant earthquake sources will consider the historical record of regional seismicity; the potential for seismicity to be induced at the site by human activities; the location, nature, and rate of Quaternary faulting in the site area; crustal stresses at seismogenic depths; evidence of neotectonic deformation in the Yucca Mountain area; and the overall tectonic framework of the region.

Study 8.3.1.17.3.2 will determine the potential locations and maximum yields of future UNEs at the NTS, considering constraints such as damage thresholds in Las Vegas. The UNE(s) that would cause the most severe ground motions at the site will then be identified using a predictive model for UNE ground motions.

Models for predicting UNE ground motions and models for predicting earthquake ground motions will be selected or developed in Study 8.3.1.17.3.3. Published ground-motion models for UNEs at NTS will be used where appropriate. If published models are not available for all ground-motion parameters needed, available data will be compiled and the needed models will be developed through regression analyses. Earthquake ground-motion data from the Great Basin and tectonically analogous areas will be tested for statistically significant deviations from published earthquake ground-motion models that have been developed for California and western North America. If the deviations are not statistically significant, a published model will be selected. If needed, new models will be developed through regression analyses.

Systematic effects on surface and subsurface ground motions resulting from the local site geology will be identified and used to correct predictions of the regional ground-motion models developed in Study 8.3.1.17.3.3. These correction factors will be based, to the extent possible, on actual ground-motion recordings obtained in Study 8.3.1.17.4.1. Theoretical models based on the wave properties of the local geology will be developed to the degree necessary to explain the observations to first order and then used to extrapolate the observations to locations and depths where ground motions must be predicted but where recordings are not available.

Identification of controlling seismic events and characterization of the resulting ground motion at the site will be accomplished in Study 8.3.1.17.3.5. Identification of the controlling seismic events will follow

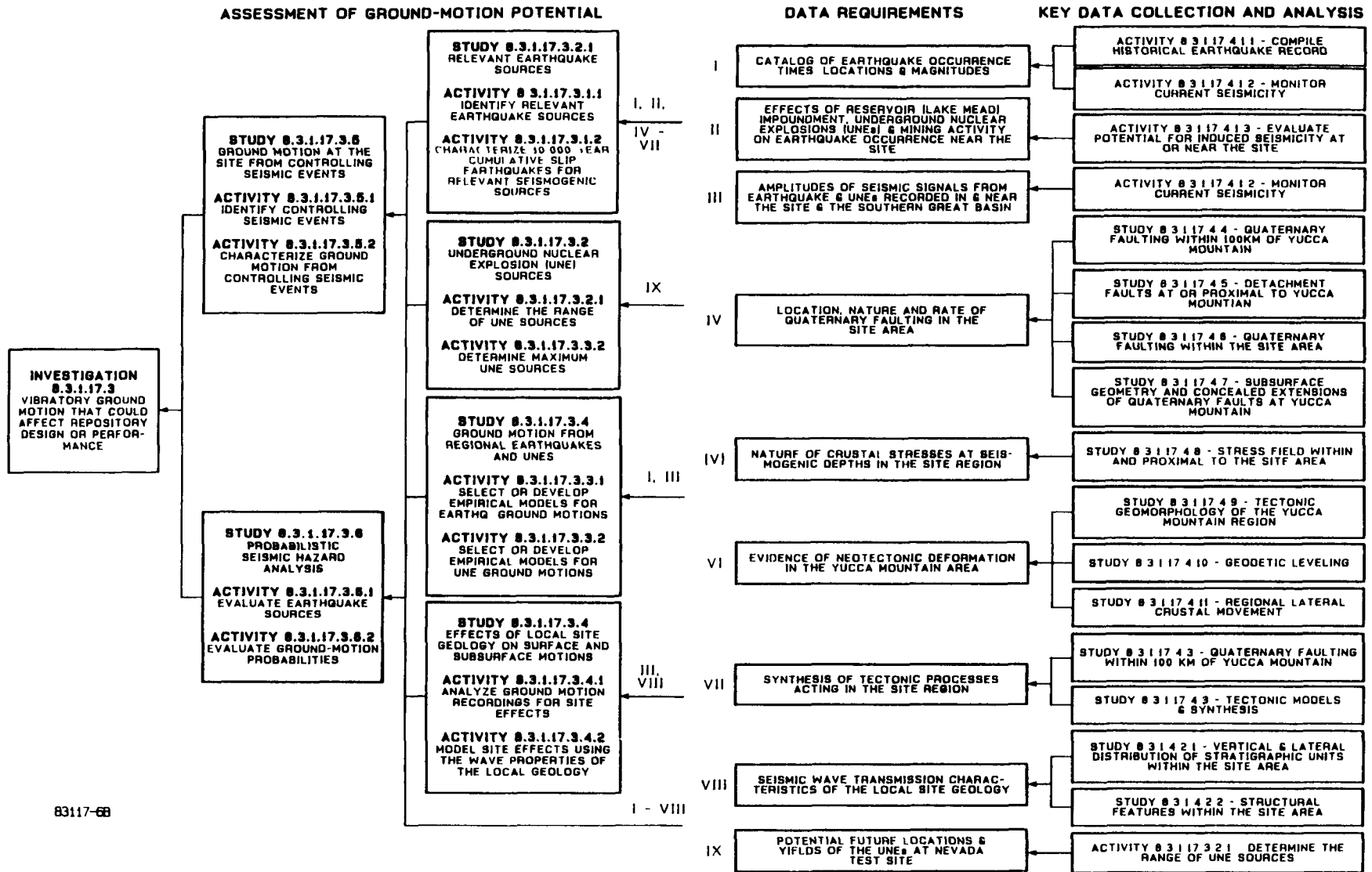

Figure 8.3.1.17-5. Logic diagram for the Investigation 8.3.1.17.3 (preclosure vibratory ground motion) (Roman numerals indicate data flow)

CONSULTATION DRAFT

directly from the identification of 10,000-year cumulative slip earthquakes on relevant sources in Study 8.3.1.17.3.1, the determination of potential maximum future UNEs in Study 8.3.1.17.3.2, the earthquake and UNE ground-motion models developed in Study 8.3.1.17.3.3, and the local site correction factors developed in Study 8.3.1.17.3.4.

Controlling-event ground motions will be characterized by suites of strong-motion time histories that are representative in terms of expected amplitudes, frequency content, and duration. Methodologies for constructing these time histories will be evaluated. Two different methodologies may be implemented and the results compared to help assess the uncertainty in the final results.

The probabilistic seismic hazard analysis of the site constitutes Study 8.3.1.17.3.6. The first step in the analysis is to identify and characterize earthquake sources that contribute to the hazard (the probability of exceeding different ground-motion levels) at the site. Sources that are more distant and sources with smaller earthquake potential than the "relevant" sources addressed in Study 8.3.1.17.3.1 will be characterized so that exceedance probabilities for ground-motion levels below the design-basis levels can be estimated. (Exceedance probabilities for motions beyond the design-basis will also be estimated.) Each seismic source will be characterized as to location, depth, shape, and magnitude-recurrence characteristics, including maximum-magnitude potential. The considerations in characterizing the contributing earthquake sources in the probabilistic analysis are essentially the same as those in characterizing relevant sources in the deterministic analysis, and so the same types of data are required.

There are different methodologies available for encoding uncertainty in seismic-source-zone interpretations and for aggregating the results of multiple interpretations in a probabilistic seismic hazard analysis. The advantages and disadvantages of available methodologies will be assessed before an approach is chosen.

A probabilistic seismic hazard analysis of the site is expected to be performed concurrently with the deterministic analysis and repeated one or more times, with detail increasing as more data become available. The sensitivity of estimated hazard to various input parameters is easy to assess within the probabilistic framework, and the preliminary analyses will help to identify the parameters of greatest importance to both the probabilistic and deterministic analyses; this information will be used to re-direct and focus the characterization activities. The calculated probabilistic hazard levels will also be used to help assess the adequacy of the deterministically derived design-basis ground motions. As was stated earlier, a measure of adequacy that is adopted here is that the annual probability of the design-basis ground motions being exceeded is 10^{-3} to 10^{-4} per year, which is the range of probabilities that appears to correspond to seismic-design bases that have been accepted for nuclear power plants in the United States

CONSULTATION DRAFT

8.3.1.17.3.1 Study: Relevant earthquake sources

The objectives of this study are to identify and characterize those earthquake sources that are relevant to a deterministic seismic hazard analysis of the site (i.e., those sources that could be active) and, if active, could cause severe ground shaking at the site. Potential earthquake sources include faults with surface geologic expression as well as concealed faults. Each seismic source will be characterized by its location, depth, orientation, likely style of faulting, and 10,000-year cumulative slip earthquake magnitude.

8.3.1.17.3.1.1 Activity: Identify relevant earthquake sources

Objectives

The objective of this activity is to identify earthquake sources that could generate severe ground motions at the site.

Parameters

The following types of information will be synthesized in this activity:

1. Maps and cross sections of historical earthquake locations.
2. Maps showing Quaternary faults with lengths greater than about 20 km within 100 km of the site and Quaternary faults with lengths greater than about 1 km within 10 km of the site.
3. Data on the style and rate of Quaternary faulting in the site region.
4. Evidence of neotectonic deformation or stability in the site region.
5. Regional heat-flow anomaly maps and regional and local magnetic-anomaly and gravity-anomaly maps.
6. Regional and local crustal seismic data.
7. Information on local and regional crustal stresses.
8. Local and regional tectonic models.

These information items will be supplied mostly by the data-collection-and-analysis activities in Investigation 8.3.1.17.4 (Figure 8.3.1.17-5).

Description

Relevant earthquake sources will be identified through a synthesis of information of the types listed in the parameter section. Surface evidence of Quaternary faulting and patterns of historical seismicity will be paramount considerations. Magnetic and gravity anomalies, crustal seismic data, and heat-flow will be analyzed for indications of faulting at depth. The

CONSULTATION DRAFT

assessment of whether a geophysical anomaly corresponds to a fault will consider information on the local structural geology and surface geomorphology. The likelihood of a buried fault being active will be evaluated considering the spatial correlation of the fault with historical seismicity, the orientation of the feature with respect to measured or inferred crustal stress orientations, potential tectonic interrelationships with other local faults, and conceptual models of the regional tectonics.

The assessment of relevance of an identified seismic source requires an assessment of the magnitude capability of the source. Hence, this activity will be performed concurrently and iteratively with the effort to define 10,000-year cumulative slip earthquakes for relevant earthquake sources in Activity 8.3.1.17.3.1.2.

Relevance to a deterministic seismic hazard analysis of the site of identified earthquake sources will be judged according to a preliminary estimation of the 10,000-year cumulative slip earthquake magnitude of the source and the distance of the source from the site, using criteria similar to the following:

<u>Source distance (R)</u>	<u>10,000-year cumulative slip earthquake magnitude (M)</u>
$0 \leq R < 3 \text{ km}$	$M > 5$
$3 \leq R < 100 \text{ km}$	$M > 4 + 2 \log_{10} R$

These criteria are illustrated graphically in Figure 8.3.1.17-6.

The distance and magnitude values cited are intended only to illustrate the conceptual approach and will be refined through analysis of the earthquake ground-motion (attenuation) relationships that will be selected or developed in Study 8.3.1.17.3.3. Any numerical criteria developed will be applied conservatively, considering the uncertainty in estimating magnitudes and ground motions, to avoid the premature screening of any potentially relevant sources.

8.3.1.17.3.1.2 Activity: Characterize 10,000-year cumulative slip earthquakes for relevant seismogenic sources

Objectives

The objective of this activity is to characterize 10,000-year cumulative slip earthquakes for each of the relevant seismogenic sources identified in the previous activity. The nature, size and location of 10,000-year cumulative slip earthquakes are to be established based on the seismogenic properties of the potential sources.

Description

The concept of 10,000-year cumulative slip earthquakes is being established to develop deterministic characterizations of potential severe vibratory ground motion for consideration in the design of repository facilities important to safety. Available data (Section 1.3) for faults in

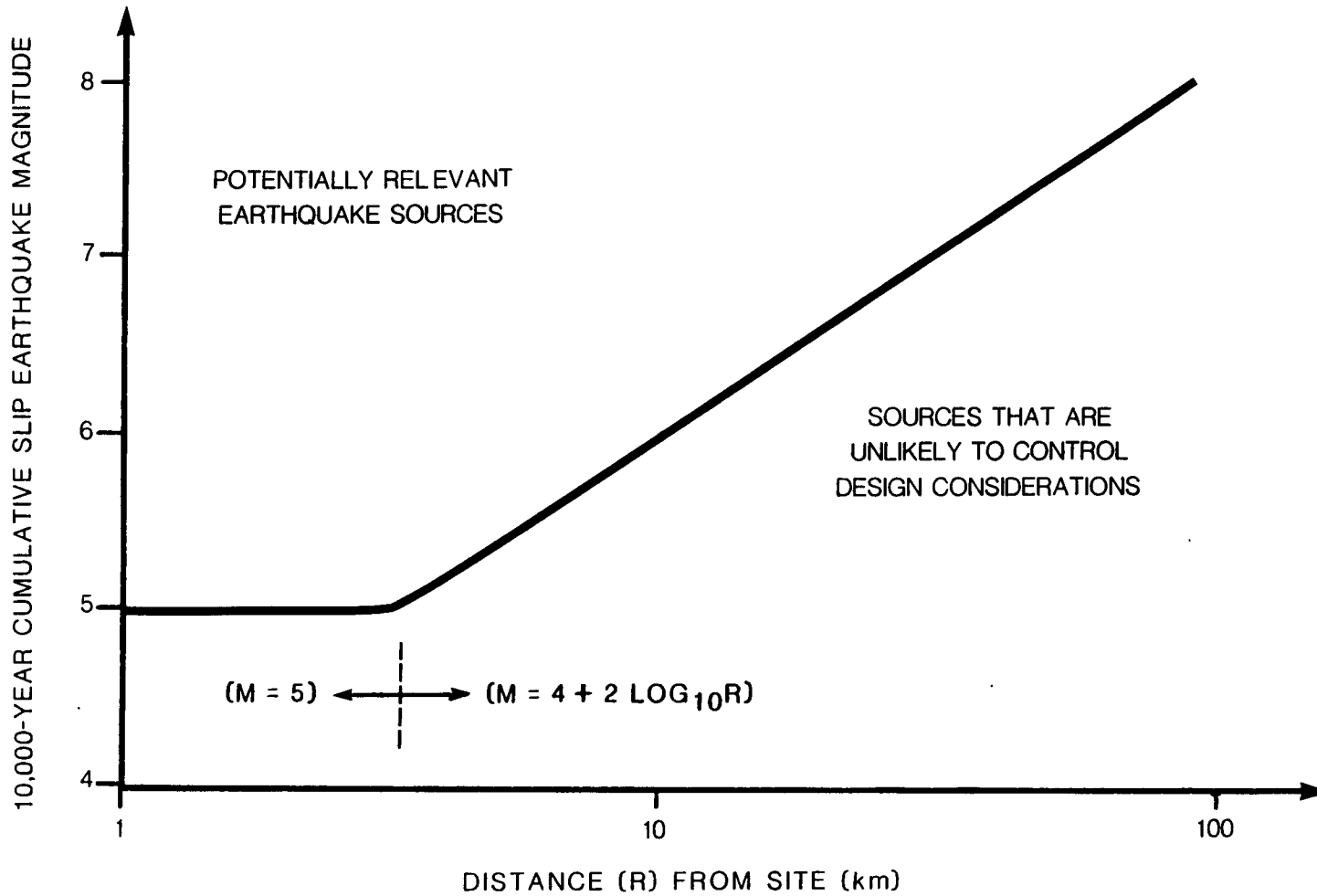

Figure 8.3.1.17-6. Conceptual approach for identifying potentially relevant earthquake sources

CONSULTATION DRAFT

the site region that have moved during the Quaternary suggest that recurrence intervals may be on the order of 1×10^4 to 1×10^5 years. Such low rates suggest that the use of fault length or displacement to develop deterministic estimates of magnitude for a given fault may be misleading. The concept of the 10,000-year cumulative slip earthquake takes recurrence rates into account, in addition to the fault characteristics, for determining a maximum magnitude for the purpose of estimating potential severe vibratory ground motion at the site. 10,000-year cumulative slip earthquakes for Quaternary faults are defined as those earthquakes that, occurring every 10,000 years, would produce the observed or estimated average Quaternary slip rate on a fault. The magnitude of a 10,000-year cumulative slip earthquake is a best estimate based on the equivalent 10,000-year displacement and available information on fault dimensions and geometry and possible interactions with other faults. To ensure applicability of the concept in cases where slip rates are such that major strain-releasing earthquakes are expected more often than every 10,000 years (e.g., the San Andreas fault), the 10,000-year cumulative slip earthquake magnitude is constrained to not exceed the best-estimate maximum magnitude. Finally, to ensure adequate conservatism of the design vibratory ground motion, an additional constraint on the magnitude is that the resulting design-basis ground motion for facilities important to safety have an annual probability of exceedance on the order of 10^{-3} to 10^{-4} per year.

Various types of data will be used to evaluate 10,000-year cumulative slip earthquakes, including estimated slip rates, mapped fault lengths, fault displacement (per event if available), fault type and other pertinent geologic data. Earthquake magnitude-frequency relationships will be estimated (using available data) considering characteristic-earthquake models or other relationships such as exponentially decaying models or maximum likelihood models. A probability distribution for true maximum magnitude, M_{max} , will be estimated for the probabilistic seismic hazard analysis of the site--Activity 8.3.1.17.3.6.1. The magnitude-frequency relationship will be used to evaluate the recurrence interval associated with M_{max} and will assist in determining whether the 10,000-year cumulative slip earthquake magnitude should differ from M_{max} .

10,000-year cumulative slip earthquakes for each relevant earthquake source will be characterized by an expected depth or depth-range and earthquake magnitude.

8.3.1.17.3.2 Study: Underground nuclear explosion sources

The objective of this study is to characterize the potential future underground nuclear explosions (UNEs) at the NTS that would result in the most severe motions at the repository site.

CONSULTATION DRAFT

8.3.1.17.3.2.1 Activity: Determine the range of UNE sources

Objectives

The objective of this activity is to determine potential locations and upper limits on the yield of future UNE tests within the NTS.

Description

Previous work on potential UNE ground motions at the site has assumed that a 700 kiloton explosion is detonated in the Buckboard Mesa area of the NTS, at a distance of 23 km from the repository shaft (Vortman, 1986). This activity will review the basis for these assumptions, in particular, the constraints on maximum UNE yields, such as damage thresholds in Las Vegas. (The current test-ban treaty threshold is 150 kiloton.) Factors that could influence the locations of future UNEs, such as terrain and rock types at the NTS, will be reviewed. Information on depth of burial as a function of yield will be compiled. Information available in the open literature is expected to be adequate to reasonably constrain the potential locations, depths, and maximum yields of future UNEs at the NTS.

8.3.1.17.3.2.2 Activity: Determine maximum underground nuclear explosion source(s)

Objectives

The objective of this activity is to identify the potential future UNE(s) that would generate the most severe ground motions at the site.

Description

UNE ground-motion (attenuation) models (which will be developed or selected in Activity 8.3.1.17.3.3.2) will be used to estimate site ground motions that would result from the largest and/or closest potential future UNEs, as identified in Activity 8.3.1.17.3.2.1. The UNE or UNEs that would generate the most severe ground motions at the site, in any frequency band of engineering significance, will be identified.

8.3.1.17.3.3 Study: Ground motion from regional earthquakes and underground nuclear explosions

Objectives

The objective of this study is to select or develop ground-motion models that are appropriate for estimating ground motion at the site from earthquakes and UNEs. These models will be used to determine the relevancy of seismic sources to a deterministic seismic hazard analysis (Activity 8.3.1.17.3.1.1), identify controlling seismic events (Activity 8.3.1.17.3.5.1), constrain simulated ground motions from controlling seismic

CONSULTATION DRAFT

events (Activity 8.3.1.17.3.5.2) and estimate the probabilities of exceeding given ground-motion levels at the site (Activity 8.3.1.17.3.6.2).

8.3.1.17.3.3.1 Activity: Select or develop empirical models for earthquake ground motions

Objectives

The objective of this activity is to select or develop empirical ground-motion models that are appropriate for estimating earthquake ground motion at the site. The models will predict ground motion as a function of earthquake magnitude and distance between the earthquake source and the site.

Parameters

Models will be determined for a number of ground-motion parameters, including peak ground acceleration and velocity, duration, and spectral amplitudes at frequencies sampled over the range of engineering significance.

Description

The approach here will be to test available ground-motion data from the Great Basin and areas elsewhere that are tectonically analogous for statistically significant deviations from published models that have been developed for California and western North America. If the deviations are not statistically significant, a published model will be selected. If the deviations are statistically significant or if published models are not available for any of the ground-motion parameters to be modeled, then new models will be developed through regression analyses. Each model selected or developed will include an explicit description of the uncertainty in the model predictions.

8.3.1.17.3.3.2 Activity: Select or develop empirical models for ground motion from underground nuclear explosions

Objective

The objective of this activity is to select or develop empirical ground-motion models that are appropriate for estimating ground motion at the site from UNEs at the NTS. The models will predict ground motion as a function of the yield and distance of the UNE.

Parameters

As for earthquakes, models will be determined for a number of ground-motion parameters, including peak ground acceleration and velocity, duration, and spectral amplitudes sampled over the range of engineering significance.

CONSULTATION DRAFT

Description

If possible, published ground-motion models for NTS explosions (Vortman, 1986) will be used. If appropriate published models are not available for all ground-motion parameters needed, available data will be compiled and the needed models will be developed through regression analyses.

8.3.1.17.3.4 Study: Effects of local site geology on surface and subsurface motions

Objectives

The objective of this study is to document systematic effects on surface and subsurface ground motions resulting from the local site geology. Local correction factors will be developed for application to predictions of the regional ground-motion models developed in Study 8.3.1.17.3.3. These correction factors will be based, to the extent possible, on instrumental recordings of ground motion obtained in Study 8.3.1.17.4.1. Theoretical models for the observed site effects will be developed to the extent necessary to explain the observations to first order and then used to extrapolate the observations to locations and depths where ground motions must be predicted but where recordings are not available.

8.3.1.17.3.4.1 Activity: Determine site effects from ground-motion recordings

Objectives

The objectives of this study are to determine, from ground-motion recordings, systematic effects of the local site geology on surface and subsurface motions, and to identify any significant site-wide bias in ground-motion levels, as compared with average levels for the southern Great Basin. These empirical determinations will be used to calibrate theoretical site-effects models in Activity 8.3.1.17.3.4.2.

Parameters

Ground-motion biases in the proximity of proposed locations of surface facilities important to safety, as compared with area averages obtained on rock sites, will be characterized using ratios of Fourier spectra and ratios of peak ground-motion parameters (peak accelerations and peak velocities). Corresponding ratios will be used to characterize reductions in ground motions recorded at the approximate depth of underground facilities as compared to area averages of surface recordings on rock sites.

Description

Ground-motion recordings will be obtained at several (3 to 6) stations located on Midway Valley, the proposed location of surface facilities. The recorded motions will be examined for variation with position to identify any

CONSULTATION DRAFT

systematic biases, particularly with respect to the depth of the valley sediments. These recorded motions and the spatial variability will be used to help calibrate theoretical models developed in Activity 8.3.1.17.3.4.2 and to determine motion averages representative of proposed locations of surface facilities important to safety.

Spectral amplification functions will be estimated by forming ratios of recorded earthquake spectra at individual locations on Midway Valley to local-array-averaged spectra obtained on nearby rock stations. Amplification factors for peak ground-motion parameters will be similarly determined. The possibility of a site-wide bias in ground-motion levels will be checked by comparing amplitudes recorded at site locations to amplitudes recorded at sites elsewhere in the southern Great Basin, for earthquakes of similar size and at comparable distances.

Downhole recordings of ground motion will be obtained at two or more depths ranging from 0.1 to 0.5 km, in addition to a surface recording at the same location, for one or more boreholes within the controlled area. The spectral amplitudes of subsurface motions will be compared with the spectral amplitudes for the corresponding surface motions and with the area averages for surface motions at rock stations. These data will be used to quantify spectral reductions in motion with depth as a function of frequency.

8.3.1.17.3.4.2 Activity: Model site effects using the wave properties of the local geology

Objectives

The objective of this activity is to develop a calibrated theoretical site-effects model for use in extrapolating the observations documented in Activity 8.3.1.17.3.4.1 to locations and depths where ground-motion predictions are needed, but where instrumental recordings are not available.

Parameters

The product of this activity will be theoretical spectral amplification functions. Corresponding amplification factors for peak-ground-motion parameters will be estimated from the spectral amplification functions, if needed.

Description

Theoretical site-effects models will be developed, based on measurements of the wave properties (shear- and compressional-wave velocities, material damping, and densities) as determined in the investigation of soil and bed-rock properties (Section 8.3.1.14.2). As part of that investigation, the seismic velocity structure of the site will be determined to a depth of at least 1 km, particularly under Midway Valley.

The approach to modeling will be to construct the simplest model that predicts the first-order features of the observed site-response functions. The initial model will assume a one-dimensional velocity structure, linear soil response, and vertically incident body waves. More complexity (e.g.,

CONSULTATION DRAFT

nonvertically incident body waves, surface waves, equivalent-linear soil response, or two-dimensional velocity structure) will be introduced as necessary.

8.3.1.17.3.5 Study: Ground motion at the site from controlling seismic events

The objectives of this study are to identify the controlling seismic events and to characterize the resulting controlling ground motions. Controlling seismic events are those UNEs or 10,000-year cumulative slip earthquakes that would generate the most severe ground motions at the site, at frequencies of engineering significance.

Two activities are included in this study.

8.3.1.17.3.5.1 Activity: Identify controlling seismic events

Objectives

The objective of this activity is to identify those UNEs or 10,000-year cumulative slip earthquakes that would produce the most severe ground motions at the site at frequencies of engineering significance. There may be more than one controlling seismic event because different events may generate the most severe ground motions in different frequency bands.

Parameters

The controlling earthquake(s) will be characterized by earthquake magnitude and hypocentral location. Controlling earthquakes will be additionally characterized by the fault strike and dip and expected slip direction. The controlling UNE(s), if any, will be characterized by distance, azimuth, depth and yield.

Description

Identification of the controlling seismic events will follow directly from the identification of 10,000-year cumulative slip earthquakes on relevant sources in Study 8.3.1.17.3.1, the identification of potential future UNEs in Study 8.3.1.17.3.2, the earthquake and UNE ground-motion models developed in Study 8.3.1.17.3.3, and the local site correction factors developed in Study 8.3.1.17.3.4. Site ground-motion parameters, including peak ground acceleration and velocity, duration, and spectral ordinates at several frequencies, will be calculated for the 10,000-year cumulative slip earthquakes and for the closest, largest potential UNEs. The seismic sources that produce the most severe ground motions as indicated by the calculated ground-motion parameters will be designated as controlling.

CONSULTATION DRAFT

8.3.1.17.3.5.2 Activity: Characterize ground motion from the controlling seismic events

Objectives

The objective of this activity is to generate suites of strong-motion time histories and corresponding response spectra that are representative in amplitude, frequency content, and duration of site ground motions that could be generated by the controlling seismic events.

Parameters

The parameters for this activity are identified in the previous section on objectives.

Description

A number of methodologies are available for simulating strong ground motions, and the first task in this activity will be to determine which method or methods will be used. At present, two general approaches appear promising.

The first approach is to scale selected instrumental strong-motion records to the sizes (earthquake magnitudes or UNE yields) and distances of the controlling seismic events. The advantage of this approach is that the instrumental records can be chosen to minimize the necessary size and distance scaling. The disadvantage of this approach is that the available strong-motion records come from locations other than Yucca Mountain and therefore reflect different site conditions and, for earthquakes, perhaps different source characteristics.

The second approach is to model motion from a controlling seismic event by a summation of motions recorded at the site for smaller events (i.e., to use the small-event records as Green's functions in the simulation of the larger, controlling event (Hartzell, 1985; Spudich, 1985)). The advantage of the Green's function summation method is that propagation-path and local-geologic effects on site ground motions are inherently accounted for. The disadvantage (for earthquakes) is the uncertainty associated with scaling source characteristics of small events to those of large events.

The feasibility of both approaches described above, and possibly others, will be evaluated for application to Yucca Mountain. It may be appropriate to implement more than one approach and compare the results to help assess the uncertainty in the final results.

The peak ground-motion parameters, durations, and spectral ordinates of the resulting time histories will be checked for consistency with the regional ground-motion models developed in Study 8.3.1.17.3.3 and any necessary corrections will be made. The spectral content of the time histories will be corrected for local site effects, as necessary, using the spectral amplification functions developed in Study 8.3.1.17.3.4.

8.3.1.17.3.6 Study: Probabilistic seismic hazards analyses

The primary objective of this study is to quantify the probability for experiencing ground motions of varying degrees of severity that might result from earthquakes of varying magnitude and distance from the site. Results from this study will be used to evaluate and constrain required technical judgments in the deterministic evaluation of design-basis ground motions (such as the determination of exceptional-earthquake magnitudes), evaluate the adequacy of the deterministic results, and help identify and focus efforts to refine those parameters that are most important for the deterministic calculations. The probabilistic hazard estimates will also provide information needed to assess the credibility of postulated accidents at the repository that might lead to releases of radioactive materials (Information Need 2.3.1, Section 8.3.5.5.1).

8.3.1.17.3.6.1 Activity: Evaluate earthquake sources

Objectives

The objective of this activity is to determine average rates for earthquake recurrence as a function of magnitude for the southern Great Basin to a distance of about 100 km from the site, and then to apportion these rates onto active faults and subregional seismic source zones.

Parameters

Earthquake sources will be characterized by location, shape, depth, and earthquake-recurrence rates as a function of magnitude, including the specification of a maximum magnitude or probability distribution for maximum magnitude.

The following types of information will be synthesized in this activity:

1. Maps and cross sections of historical earthquake locations.
2. Maps showing Quaternary faults with lengths greater than about 20 km within 100 km of the site and Quaternary faults with lengths greater than about 1 km within 10 km of the site.
3. Data on the style and rate of Quaternary faulting in the site region.
4. Evidence of neotectonic deformation or stability in the site region.
5. Regional and local magnetic-anomaly and gravity-anomaly maps.
6. Regional and local crustal seismic data.
7. Information on local and regional crustal stresses.
8. Local and regional tectonic models.

CONSULTATION DRAFT

Description

The earthquake catalog developed in Study 8.3.1.17.4.1 will be used to determine the rate that earthquakes have occurred in the region surrounding the site during historical time as a function of magnitude. The completeness of the historical earthquake record in different areas and time intervals will be evaluated considering the number of events reported in the catalog as a function of magnitude and time, past human population distributions, and past distributions of recording instruments. Additional checks will be made to reconcile the gross rates of crustal deformation for the southern Great Basin with deformation rates implied from observations of seismic-moment release rates. Estimates of the upper-magnitude limits for earthquakes in this area will be required to translate rates of earthquake occurrences to rates of crustal deformations. From these investigations, best estimates, accompanied by estimates of uncertainty, will be developed for characterizing the regional rate of earthquake occurrences.

This regional rate of earthquake occurrences will then be apportioned onto active faults and subregional source zones according to models of the local and regional tectonics. More than one model will likely be required for apportioning the earthquake activity in order to express the uncertainty in current scientific interpretations and to focus efforts to refine those source representations that have the greatest impact on the site.

In this activity, seismologic and geologic data will be used to interpret earthquake sources that contribute to the probability of exceeding given ground-motion levels at the site in essentially the same manner as they will be used in Study 8.3.1.17.3.1 to interpret earthquake sources that might control site ground motions in a deterministic hazard analysis. See the description sections of Activities 8.3.1.17.3.1.1 and 8.3.1.17.3.1.2. The scope of this activity is more comprehensive in that more seismic sources will be characterized, multiple interpretations of seismic sources will most likely be retained and their relative likelihoods judged, any dependencies in the interpreted existence of source zones (e.g., perfect dependence or mutual exclusiveness of some sources) must be specified, and maximum magnitudes must be estimated explicitly.

Source-zone maps will be produced by this activity to indicate the earthquake probability as a function of magnitude and location within the southern Great Basin.

Methods and technical procedures

The methods and technical procedures for Activity 8.3.1.17.3.6.1 are given in the following table.

CONSULTATION DRAFT

Method	Technical procedure		Date
	Number	Title	
	(NWM-USGS-)		
Integration of regional seismic and geologic data	SP-02, RO	Procedure for calculating frequency of recurrence curves	14 Sept 81
	SP-03, RO	Seismic zoning procedure	14 Sept 81
	SP-08, RO	Seismic study of the tectonic environment	06 June 83

²TBD = to be determined.

8.3.1.17.3.6.2 Activity: Evaluate ground motion probabilities

Objectives

The objectives of this activity are (1) to estimate the probability of exceeding given ground-motion levels at the site, and (2) to integrate the contributions to that probability from all identified earthquake sources that could generate potentially damaging ground motion at the site.

Parameters

The basic information items needed for a probabilistic seismic hazard analysis are as follows:

1. Boundaries of seismic source zones, including, if warranted, alternative interpretations and corresponding judgments of the relative likelihood that each interpretation is correct.
2. Earthquake-magnitude recurrence rates for each source zone, including estimates of maximum magnitudes and assessments of uncertainty.
3. Specification of any dependencies in the interpreted existence or activity of source zones (e.g., perfect dependence or mutual exclusiveness of some sources).
4. Ground-motion (attenuation) models for predicting expected values and variances of required ground-motion parameters (e.g., peak velocity) as a function of distance and source size.

CONSULTATION DRAFT

Description

There are a number of software packages available for computing probabilistic seismic hazard estimates given the information listed in the parameters section (e.g., codes developed by the Electric Power Research Institute (EPRI, 1986) and Lawrence Livermore National Laboratory (Bernreuter et al., 1986)). Some codes embody different means of propagating uncertainties through the analysis to the final results, and the alternative approaches will be evaluated. It may be appropriate to calculate hazard levels using different codes for comparison.

As stated previously, the probabilistic seismic hazard analysis will be performed iteratively, in parallel with the deterministic hazard analysis. The sensitivity of calculated hazard to different input parameters will be tested to identify what interpretations impact the site the most and may, therefore, warrant refinement. The final hazard estimates will be compared with the deterministically derived design-basis ground motions to verify that they correspond to annual exceedance probabilities of 10^{-3} to 10^{-4} per year.

Methods and technical procedures

The methods and technical procedures for Activity 8.3.1.17.3.6.2 are given in the following table.

Method	Technical procedure		Date
	Number	Title	
Probabilistic hazard calculations	TBD ^a	Probabilistic ground-motion calculations	TBD

^aTBD = to be determined.

8.3.1.17.3.7 Application of results

Information on vibratory ground motion will be used as follows:

1. In the development and analysis of the repository design (Issue 4.4, technical feasibility, Section 8.3.2.5).
2. In the determination of credible accidents that are applicable to the repository (Issue 2.3, accidental radiological releases, Section 8.3.5.5).
3. In the determination that waste can be accessed and removed from the emplacement boreholes throughout the retrievability period for normal and off-normal conditions (Issue 2.4, waste retrievability, Section 8.3.5.2).

CONSULTATION DRAFT

4. In the identification of normal and accident conditions, including disruptive events (Issue 2.7, repository design criteria on radiological safety, Section 8.3.2.3).

8.3.1.17.3.8 Schedule and milestones

This investigation, addressing vibratory ground motion contains six studies: 8.3.1.17.3.1 (relevant earthquake sources), 8.3.1.17.3.2 (under-ground nuclear explosion (UNE) sources), 8.3.1.17.3.3 (ground motion models), 8.3.1.17.3.4 (local site effects), 8.3.1.17.3.5 (controlling ground motion), and 8.3.1.17.3.6 (probabilistic seismic hazard analysis). In the figure that follows, the schedule information for these studies is presented in the form of timelines. The timelines extend from implementation of the approved study plans to the issuance of the final products associated with the studies. Summary schedule and milestone information for this investigation can be found in Section 8.5.1.1.

The study on UNE sources (8.3.1.17.3.2) is ongoing. The other studies are expected to begin within the first year of site characterization.

The activities of this entire investigation are planned to progress in parallel with performance and design activities in an iterative fashion. The results of these studies will be toward the resolution Issues 1.1 (total system performance), 1.8 (NRC siting criteria), and 1.10 (waste package characteristics) and to support repository design. Information from these studies will be considered in both advanced conceptual and license application design. This information will also be used in the resolution of issues related to preclosure safety.

The studies in this investigation are not seriously constrained by other program elements. Within this investigation, however, several studies depend upon each other as indicated.

The study numbers and titles corresponding to the timelines are shown on the left of the following figure. The points shown on the timelines represent major events or important milestones associated with the study. Solid lines represent study durations and dashed lines show interfaces.

CONSULTATION DRAFT

STUDY

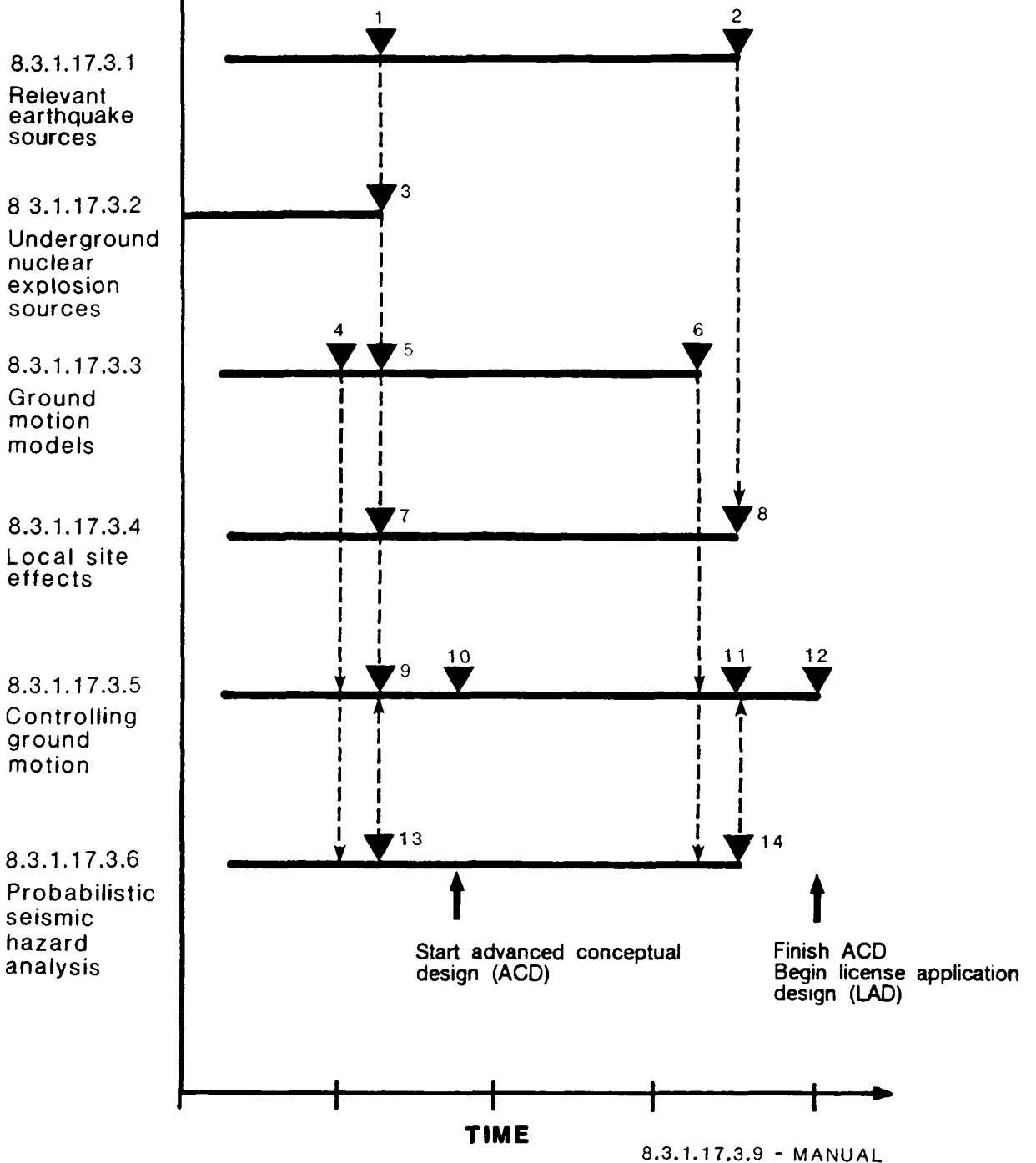

CONSULTATION DRAFT

The points on the timeline are described in the following table:

<u>Point number</u>	<u>Description</u>
1	Preliminary report: Earthquake sources relevant to the Yucca Mountain site and determination of 10,000-year cumulative slip earthquakes. Results are needed for the preliminary determination of controlling (design-basis) ground motion in Study 8.3.1.17.3.5.
2	Milestone Q164. Final Report: Earthquake sources relevant to the Yucca Mountain site and determination of 10,000-year cumulative slip earthquakes. Results are needed for the final determination of controlling ground motion in Study 8.3.1.17.3.5.
3	Milestone Q166. Final report: Potential maximum yields and locations of underground nuclear explosions relative to the Yucca Mountain site. Results are needed for the preliminary determination of controlling ground motion in Study 8.3.1.17.3.5.
4	Preliminary report: Earthquake ground-motion (attenuation) models appropriate for the Yucca Mountain site. Results are needed for the preliminary determination of controlling ground motion in Study 8.3.1.17.3.5 and for the preliminary probabilistic seismic hazard analysis Study 8.3.1.17.3.6.
5	Final Report: Underground nuclear explosion ground-motion (attenuation) models appropriate for the Yucca Mountain site. Results are needed for the preliminary and final determinations of controlling ground motion in Study 8.3.1.17.3.5.
6	Milestone Q165. Final report: Earthquake ground-motion (attenuation) models appropriate for the Yucca Mountain site. Results are needed for the final determination of controlling ground motion in Study 8.3.1.17.3.5 and for the final probabilistic seismic hazard analysis in Study 8.3.1.17.3.6.
7	Preliminary report: Effects of local site geology on surface and subsurface ground motions. Results are needed for the preliminary determination of controlling ground motion in Study 8.3.1.17.3.5 and for the preliminary probabilistic seismic hazard analysis in Study 8.3.1.17.3.6.
8	Milestone Q168. Final report: Effects of local site geology on surface and subsurface ground motions. Results are needed for the final determination of controlling ground motion in Study 8.3.1.17.3.5 and for the final seismic hazard analysis in Study 8.3.1.17.3.6.

CONSULTATION DRAFT

<u>Point number</u>	<u>Description</u>
9	Preliminary report: Methodologies for simulating strong ground motion for consideration in the design of a high-level nuclear waste repository at Yucca Mountain. Results are needed for the preliminary determination of controlling ground motion in this study.
10	Issue report: Description of strong ground motion to be considered in the advanced conceptual design of a high-level nuclear waste repository at Yucca Mountain.
11	Final report: Methodologies for simulating strong ground motion for consideration in the design of a high-level nuclear waste repository at Yucca Mountain. Results are needed for the final determination of controlling ground motion in this study.
12	Milestone Q169. Issue report: Description of strong ground motion to be considered in the license application design of a high-level nuclear waste repository at Yucca Mountain.
13	Milestone M387. Preliminary report on the probabilistic seismic hazard analysis of the Yucca Mountain site. Results are needed for the preliminary determination of controlling ground motion in Study 8.3.1.17.3.5.
14	Milestone Q167. Final report: Probabilistic seismic hazard analysis of the Yucca Mountain site. Results are needed for the final determination of controlling ground motion in Study 8.3.1.17.3.5.

8.3.1.17.4 Investigation: Preclosure tectonics data collection and analysis

Technical basis for obtaining the information

Link to technical data chapters and applicable support documents

The following sections provide a summary of existing data relevant to this investigation:

<u>SCP section</u>	<u>Subject</u>
1.3.1	Tectonic framework
1.3.2	Tectonic history
1.4.1	Seismology of the southern Great Basin
1.4.2	Seismology of Yucca Mountain
1.5.1	Volcanism
1.5.2	Faulting
1.5.3	Vertical and lateral crustal movement
1.8.1	Summary of significant results

CONSULTATION DRAFT

Parameters

Information to be provided by the studies under this investigation include the following:

1. Catalog of historical earthquake occurrence times, locations, and magnitudes.
2. Analysis of potential for UNEs, mining activity, or reservoir (Lake Mead) impoundment to induce seismicity near the site.
3. Recordings obtained at the site and at other locations in the southern Great Basin of ground motions from earthquakes and UNEs.
4. Geological and geophysical evidence of large-scale Quaternary faulting within 100 km of the site and of smaller-scale Quaternary faulting in the site area.
5. Analysis of the seismogenic potential of detachment faults in the site area.
6. Evaluation of crustal stresses at seismogenic depths in the site region.
7. Morphologic and morphometric analysis of neotectonic deformation in the site region.
8. Geodetic and survey evidence of recent crustal movements in the site region.
9. Synthesis of tectonic processes acting in the site region (development of tectonic models).

Purpose and objectives of the investigation

The primary purpose of this investigation is to provide data and analyses that are required by Investigation 8.3.1.17.2, assessment of fault displacement that could affect repository design or performance, and Investigation 8.3.1.17.3, assessment of vibratory ground motion that could affect repository design or performance (refer to logic diagrams for these two investigations, Figures 8.3.1.17-4 and 8.3.1.17-5). The limited data collection and analysis that is required by Investigation 8.3.1.17.1, volcanic activity that could impact the repository, will be performed within that investigation (Figure 8.3.1.17-3).

Technical rationale for the investigation

The data-collection-and-analysis studies have been aggregated under this fourth investigation for two reasons. Much of the information that will be provided by the data-collection-and-analysis studies is needed for more than one assessment. For example, information on Quaternary faulting near the site is germane to both the faulting and the ground-motion potential at the site. Also, most of the studies are most naturally organized around a geological problem, the solution of which may require a broader focus than the repository site itself. All studies are intended to contribute to the

CONSULTATION DRAFT

resolution of design or performance issues, even though the linkage may sometimes be indirect for studies that have a broad focus, such as the evaluation of tectonic models (Study 8.3.1.17.4.12).

8.3.1.17.4.1 Study: Historical and current seismicity

The objective of this study is to compile information on reported and instrumentally recorded earthquakes that characterize the earthquake potential near Yucca Mountain. This information will be used (1) to help identify and characterize potentially relevant earthquake sources for the deterministic hazard analysis (Study 8.3.1.17.3.1) and potentially contributing earthquake sources for the probabilistic hazard analysis (Study 8.3.1.17.3.6), (2) to develop regional earthquake ground-motion models (Activity 8.3.1.17.3.3.1), and (3) to determine local-geologic and depth-of-burial effects on ground motion at the site (Activity 8.3.1.17.3.4.1).

8.3.1.17.4.1.1 Activity: Compile historical earthquake record

Objectives

The objective of this activity is to compile a record of historical seismic events in the southern Great Basin or within 100 km of Yucca Mountain. The record will be as complete and accurate as is reasonably achievable, and will indicate whether each cataloged seismic event is thought to be a natural earthquake, induced earthquake, UNE, cavity collapse, or blast. For potentially damaging earthquakes ($M \geq 5.5$) in the study region, available information will be compiled on ground-motion intensity, availability of strong-motion records, and extent and style of faulting.

Parameters

Parameters to be compiled for recorded seismic events include the following:

1. Date.
2. Origin time.
3. Hypocentral location.
4. Hypocenter uncertainty estimate.
5. Magnitude (and magnitude type).
6. Magnitude uncertainty estimate.
7. Annotation of whether the event is an earthquake, UNE, cavity collapse, etc.

CONSULTATION DRAFT

Additional parameters to be compiled as available for the larger ($M \geq 5.5$) earthquakes include the following:

1. Focal mechanism (dip, strike, and rake).
2. Seismic moment.
3. Stress drop.
4. Extent of surface rupture.
5. Epicentral intensity.
6. Epicentral intensity uncertainty estimate.
7. Total felt area.
8. Falloff of intensity with distance.
9. Peak ground accelerations.
10. Peak ground velocities.
11. Durations.
12. Selected spectral amplitudes.

Description

The required parameters will be obtained primarily through a literature survey. Meremonte and Rogers (1987) have compiled a catalog of historical earthquakes in the southern Great Basin that provides most of the needed information. The catalog will be updated periodically to add new information, and the geographic coverage of the catalog may need to be extended somewhat to cover all areas of interest. Also, uncertainty estimates for magnitudes and epicentral intensities need to be added to the catalog. Most of the additional parameters for the larger earthquakes will also be obtained from the literature. If source parameters (focal mechanism, seismic moment, and stress drop) have not been published for any of the larger earthquakes in the record and sufficient data are available to determine them, these data will be obtained and the source parameters will be determined.

8.3.1.17.4.1.2 Activity: Monitor current seismicity

Objectives

The objective of this activity is to provide empirical information on how often earthquakes are currently occurring in the southern Great Basin; what the orientation, depth, and style of faulting are; how seismic wave amplitudes scale with magnitude and attenuate with distance in the region; and how ground motions vary with depth and with surface geology in the site area. The information on faulting and earthquake location and recurrence will be used to identify potentially relevant earthquake sources for the deterministic hazard analysis (Study 8.3.1.17.3.1) and potentially contributing earthquake sources for the probabilistic hazard analysis (Study 8.3.1.17.3.6). The information on magnitude and distance scaling will be used to develop regional ground-motion models (Study 8.3.1.17.3.3). The data on ground-motion variations at the site will be used to develop site correction factors and response functions (Study 8.3.1.17.3.4). Recordings obtained at Yucca Mountain of small earthquakes may be used as Green's functions in the simulation of controlling earthquake motions (Activity 8.3.1.17.3.5.2).

CONSULTATION DRAFT

Parameters

Parameters to be compiled for recorded seismic events include the following:

1. Date.
2. Origin time.
3. Hypocentral location.
4. Hypocenter uncertainty estimate.
5. Magnitude (and magnitude type).
6. Magnitude uncertainty estimate.
7. Annotation of whether the event is a earthquake, UNE, cavity collapse, etc.

For the larger ($M \geq 5.5$) earthquakes, available information will be compiled as follows:

1. Focal mechanism (strike, dip, and rake).
2. Seismic moment.
3. Stress drop.
4. Extent of surface rupture.
5. Epicentral intensity.
6. Epicentral intensity uncertainty estimate.
7. Total felt area.
8. Falloff of intensity with distance.
9. Peak ground accelerations.
10. Peak ground velocities.
11. Durations.
12. Spectral amplitudes.

Description

Current seismicity will be monitored by a regional seismograph network, a local accelerograph array, and a portable array of digital seismic event recorders that can be deployed with seismometers, accelerometers, or both. The southern Great Basin (SGB) regional seismograph network has been in operation since 1978 (Rogers et al., 1981; 1983) and will continue to be operated and maintained. The SGB network consists of 49 high-gain seismograph stations within a 150-km radius of Yucca Mountain and an additional subnet of six seismometers on Yucca Mountain, providing a local detection threshold of about local magnitude (M_L) 0.0, and a regional detection threshold of about M_L 1.0.

The output of each seismometer in the SGB network is converted to an FM radio signal and telemetered via microwave links and telephone lines to Golden, Colorado. The bandwidth and dynamic range of the current seismometer-telemetry system is somewhat limited. For example, the usable dynamic range (of about 40 dB) is such that a local earthquake that is

CONSULTATION DRAFT

recorded with good fidelity in one area of the network will likely be in the noise or off-scale in another area of the network because of the attenuation of earthquake ground motion with distance. It may, therefore, be appropriate to upgrade the network recording capability. A subtask of this activity is to assess what enhancements of recording capability are needed, if any, to provide the required data parameters. If warranted, available options for enhancing network performance will be evaluated and an appropriate option will be implemented.

A local accelerograph array will be installed at the site, with about a half-dozen three-component transducers located on Yucca Mountain and in Midway Valley. The primary purpose of this array will be to record, on scale, strong ground motions from a nearby moderate-to-large earthquake should one occur.

A portable array of digital seismic event recorders with about a 30-channel capacity will be used for special studies, such as obtaining high-dynamic-range data that are suitable for calculating earthquake source parameters (e.g., stress drop and moment), obtaining accurate aftershock locations, monitoring microseismicity in the vicinity of suspect tectonic features, or measuring local site effects on ground motion.

It will be useful to record with good fidelity a number of UNEs from the NTS at surface and subsurface locations on Yucca Mountain and near the sites of prospective surface facilities in Midway Valley. Such records will enable regression relations for UNE ground motions to be calibrated against actual observations at the site and will provide important information on the local variability of surface ground motion and on the variation of ground motion with depth. These data could be obtained by adding seismometers and higher-gain channels to the local accelerograph array (in which case digital recording for the array would be indicated) or by a several-year deployment of portable digital event recorders. The costs and benefits of each approach will be evaluated and the most cost-effective approach will be implemented.

8.3.1.17.4.1.3 Activity: Evaluate potential for induced seismicity at the site

Objectives

The objective of this activity is to evaluate the potential for human activities to significantly perturb the natural seismic hazard at the site by inducing seismicity at or near the site. To date, the human activities that have been identified as having a potential to induce seismicity in the site region are the impoundment of Lake Mead, the testing of nuclear devices at NTS, and the mining of the repository itself. The information developed in this activity will be used in estimating of magnitude-recurrence relationships for earthquake sources that are relevant to the deterministic hazard analysis (Activity 8.3.1.17.3.1.1) and for earthquake sources that contribute to the probabilistic seismic hazard at the site (Activity 8.3.1.17.3.6.1).

CONSULTATION DRAFT

Parameters

Data needed for this activity include

1. Historical catalog of southern Great Basin earthquakes.
2. Locations, times, and yields of UNEs at the NTS.
3. Survey of literature on seismicity induced by the impoundment of Lake Mead.
4. Survey of literature on mining-induced seismicity (rock bursts).

Information to be provided by this activity includes

1. Correlation between earthquake occurrences and UNE occurrences.
2. Correlation between earthquake occurrences and the impoundment of Lake Mead.
3. Identification of induced earthquakes in the historical catalog.
4. Assessment of likelihood of mining induced seismicity.

Description

The catalog of southern Great Basin earthquakes will be examined to determine if significant changes in rates of occurrence of earthquakes are detectable following nuclear tests at the NTS. An estimate of background levels of seismicity in various annuli surrounding Pahute Mesa and Yucca Flats will be compared with seismicity levels in those annuli for short time spans (on the order of several hours to several weeks) following nuclear tests. A search for significant differences in rates will be conducted. If a statistically significant increase in earthquake activity (after-shocks) following nuclear tests is found, the correlation between earthquake rates and UNEs will be evaluated as a function of distance from the test, time after the test, and yield of the test. The feasibility of correcting historical earthquake-recurrence rates for bias from nuclear-event after shocks will be explored, as will the means of identifying individual induced events in the historical catalog.

Because Lake Mead is about 120 mi from the site, it is not expected that reservoir-induced seismicity will impact the site. A survey of the literature on Lake Mead-induced earthquakes will be performed to confirm this expectation. Should the literature survey prove inconclusive, a statistical analysis will be performed of the correlation between earthquake occurrences, distance from the lake, time since impoundment, and fluctuations in water level.

Mining-induced earthquakes (rock bursts) are believed to occur when relatively small local cavity stresses trigger failure in a much larger volume of highly prestressed rock. This type of failure has occurred mostly in deep mines (McGarr, 1984) under conditions where rock sample testing shows the rock to be both very strong and very brittle (McGarr et al., 1975).

Sudden exfoliation has accompanied excavation at shallow depths in granite quarries (Suppe, 1985). The failure is apparently associated with a "buckling beam" instability as slabs of rock flex upward as the load is removed. This is associated with large horizontal compressive stresses.

Of particular relevance to the planned excavations in Yucca Mountain is experience from coal mines in the eastern Wasatch Plateau. Earthquake-like activity, clearly related to mining, extends from near the base of the mine to some depth (Williams, 1987). However, the activity is associated with the removal of massive amounts of material (several million tons per year) that is then transported far from the site.

Considerable mining experience exists at the NTS (e.g., Zimmerman and Finley, 1987) and no reports of mine-induced catastrophic failure are known. The prospective Yucca Mountain mine excavation will not be much greater in size and no deeper than other cavities on the test site and will be tiny when compared with the Utah coal workings. Also, the material mined will be left on the surface to minimize the change of loading.

No examples of explosive catastrophe associated with conditions of extensional tectonics similar to those found in Yucca Mountain have been found in a limited survey of the literature. A more comprehensive review of the literature will be performed to increase the confidence in this finding. In the improbable event that seismic activity does appear when excavation starts, its study will, at least in the first instance, be covered by the standard needs of the seismology program.

8.3.1.17.4.2 Study: Location and recency of faulting near prospective surface facilities

Two activities are included in this study.

8.3.1.17.4.2.1 Activity: Identify appropriate trench locations in Midway Valley

Objectives

The objective of this activity is to identify appropriate trench locations at proposed locations for repository surface facilities that are important to safety through detailed geologic mapping and remote sensing studies. The recommended locations will be used in trenching investigations in Activity 8.3.1.17.4.2.2.

Parameters

The parameters for this activity include

1. Displacement history on mappable faults in bedrock and alluvium.

CONSULTATION DRAFT

2. Distribution of mappable surficial deposits (1:5000 scale) based on regional geomorphic categorization.
3. Ages of units in (2); absolute where possible and relative otherwise.
4. Topographic features or lineaments that may be expressions of previous fault rupture.
5. Potential for surface rupture from underlying structural features.

Description

The alluvial area in Midway Valley and adjacent bedrock on Exile Hill will be mapped geologically at a scale of 1:5000. The bedrock units are to be identified according to attitude, distribution, age, and salient features, e.g., weathering, fracturing, composition, and texture (size of particles and mineral components). The surficial deposits will be mapped using geomorphic expression, degree of carbonate cementation, and lithology. The mapping will be supplemented by small test pits, coupled with subsurface data obtained from existing boreholes and geophysical profiles. The mapping will be carried out using existing color aerial photography and observations from field traversing.

Tiva Canyon units of the Paintbrush Tuff are the only bedrock expected; preliminary mapping has identified caprock, upper cliff, and upper lithophysal units. Only minor faults have been observed on the east side of Exile Hill, and a geologic map and accompanying geologic cross sections (Scott and Bonk, 1984) are inconclusive regarding extent of faulting. Neal (1986) indicates that closely spaced faults (<50 m) occur beneath the surficial deposits, but not necessarily on the exposed part of the east flank of Exile Hill. Q1, Q2, and QTa deposits are known to occur, based on preliminary mapping by Swadley et al. (1984). Faults are not believed to penetrate alluvial units; surface expression is not evident.

The mapping will use commonly recognized chronology for Quaternary units, i.e., Holocene (Q1), intermediate (Q2), and older (QTa). Age assignments will be based on chronostratigraphic correlation (e.g., relative to known, dated units such as the Bishop ash (738,000 years)), on dating of deposits using applicable soil techniques where possible, and on correlations based on geomorphic expression and lithology.

The dating of stratigraphic or soil horizons frequently depends on extrapolation of mapped units and generally must be grouped within broad age categories. Dating by almost any method is subject to limitations inherent in the methods (Szabo et al., 1981; Rosholt, 1985). Several appropriate dating methods are possible for use at Yucca Mountain and more than one method of dating may be required to establish confidence at a given location.

The siting approach for the waste handling building is to position it where there is no evidence of faults with Quaternary slip rates exceeding 0.001 mm/yr or faults that measurably offset materials less than 100,000 yr old (refer to discussion of purpose and objectives of Investigation 8.3.1.17.2, studies to provide information on fault displacement that could

affect repository design or performance). Possible areas of Quaternary faulting will be identified by interpreting aerial photography of various scales and sun-angles in addition to the geologic mapping. Remote sensing studies will identify linear topographic breaks, alignment of drainages, or vegetation changes that could be related to Quaternary faulting. Any lineaments that are found will be investigated on the ground during the geologic mapping. Areas of suspected Quaternary faulting may also be investigated using topographic profiling or shallow geophysical techniques (e.g., seismic refraction and reflection).

Methods and technical procedures

The methods and technical procedures for Activity 8.3.1.17.4.2.1 are given in the following table.

Method	Number	Technical procedure	
		Title	Date
Evaluation of surface geologic features	SNL TP-0068	Surface geologic mapping	31 July 87

8.3.1.17.4.2.2 Activity: Conduct exploratory trenching in Midway Valley

Objectives

The objective of this activity is to investigate the possible occurrence of late Quaternary surface fault rupture in the vicinity of planned surface facility locations important to safety and to identify sites without evidence of significant late Quaternary faulting. This activity will provide input into the location and design of surface facilities important to safety, particularly those associated with waste handling.

Parameters

The primary parameter of this activity is the demonstration of the absence of late Quaternary faults with more than 10 cm offset within the last 100,000 years in the immediate vicinity of planned surface structures important to safety.

Description

The suitability of the proposed site of the waste-handling facilities will be evaluated by excavating a trench across the site, in the surficial deposits of Midway Valley. The proposed sites of any other surface facilities identified as being important to safety will be explored by excavating similar trenches.

The trenching pattern to be used will either be a cross centered on the proposed site with arms extending in a north-south and east-west direction or

CONSULTATION DRAFT

a perimeter trench around the waste-handling facility. The trenches will be excavated to a depth that exposes material at least 100,000 yr old and preferably substantially older (including Q_{Ta} deposits). Older deposits are preferred because of the added potential for detecting cumulative displacements on minor faults. The trenches will also be excavated deep enough to expose bedded material that can be reliably used to detect displacements.

One wall of the trenches will be logged in sufficient detail to demonstrate the continuity of bedding and the absence of displacement. More detailed investigations will be conducted in areas where faulting is suspected or cannot be disproved. The deposits exposed by the trenches will be dated using applicable techniques or by correlation with nearby dated deposits. Credible demonstration of the absence of faulting during the late Quaternary and the estimation of slip rates on observed faults will rely on the accuracy of measured or extrapolated ages of deposits.

Additional trenching across Midway Valley will be considered, pending the results of the above trenching.

Methods and technical procedures

The methods and technical procedures for Activity 8.3.1.17.4.3.2 are given in the following table.

Method	Technical procedure		
	Number	Title	Date
Surface geologic mapping	SNL TP-0068	Surface Geologic Mapping	30 July 87
Logging trench wall	SNL TP-0069	Trench-wall Mapping	30 July 87
Dating of Quaternary deposits	SNL TP-0071	Geologic Age Dating	30 July 87

8.3.1.17.4.3 Study: Quaternary faulting within 100 km of Yucca Mountain, including the Walker Lane

The objectives of this study are (1) to identify Quaternary faults within 100 km of Yucca Mountain, and (2) to characterize those faults capable

of future earthquakes with magnitude such that associated ground shaking could impact design or affect performance of the waste facility. This study is complemented by more specialized studies of faults at and proximal to the site. These Studies are 8.3.1.17.4.2 (faulting potential near prospective surface facilities); 8.3.1.17.4.6 (Quaternary faulting within the site area); 8.3.1.17.4.4 (Quaternary faulting proximal to the site within northeast-trending fault zones); 8.3.1.17.4.5 (detachment faults at or proximal to Yucca Mountain).

The existing geologic and geophysical data base for Yucca Mountain and areas to the north and east is substantial. That area (Figure 8.3.1.17-7) is covered in its entirety by modern geologic maps of bedrock at a scale of 1:24,000 or larger, and the information contained therein is supplemented by numerous specialized geologic and geophysical studies. Areas (Figure 8.3.1.17-8) to the south (Amargosa Desert) and west (Crater Flat, Bare Mountain, Beatty area) are less well known. Mapping of Quaternary geology, including distribution of Quaternary geologic materials, and analysis of Quaternary geomorphic evolution is not yet complete.

Yucca Mountain lies within a northwest-trending zone of structural transition between parts of south-central Nevada characterized by north-trending basins and ranges, and the Inyo-Mono area of eastern California, characterized by northwest-trending basins and ranges. This zone of transition was referred to as the Walker Belt by Stewart (1980). The northeastern boundary of the zone is diffuse; the southwestern boundary is formed by the Death Valley-Furnace Creek fault zone (Carr, 1984), a right-lateral wrench fault that cuts Holocene deposits over much of its extent. The Walker Belt contains within it zones of wrench faulting, including the Las Vegas Valley shear zone on the southeast and the shear zone near Cedar Mountain on the northwest (Gianella and Callaghan, 1934b). These shear zones were thought to be elements of a continuous zone of right-lateral shearing that was named the Walker Lane by Locke et al. (1940) (Figure 8.3.1.17-9).

The Walker Belt, then, is the zone of structural transition between adjacent structural provinces, and the Walker Lane is the postulated through-going zone of right-lateral faulting located within the Walker Belt. The Walker Lane is not a continuous linear fault, at least at the surface. Near Cedar Mountain, site of the $M = 7.2$ to 7.3 earthquake of 1932, the shear zone is interpreted to be structurally overlain by a detached upper plate of Tertiary volcanic and sedimentary rocks (Molinari, 1984). According to Molinari (1984), right-lateral movement on the subsurface shear zone during the 1932 earthquake was expressed by movement of small, en echelon faults in the overlying upper plate.

At the Nevada Test Site, the Las Vegas Valley shear zone, which forms the southeastern element of the Walker Lane, as defined by Gianella and Callaghan (1934b) and Locke et al. (1940), cuts Paleozoic rocks and is overlain by Oligocene-Miocene sedimentary deposits and Miocene ash flows (Ekren, 1968). The Oligocene-Miocene rocks are thought to be part of an upper plate (Figure 8.3.1.17-10) that is structurally detached from subjacent basement blocks bounding either side of the subsurface extension of the Las Vegas Valley shear zone (Burchfiel, 1965). An alternative interpretation is that the Las Vegas Valley shear zone curves westward and, concealed below the upper plate,

CONSULTATION DRAFT

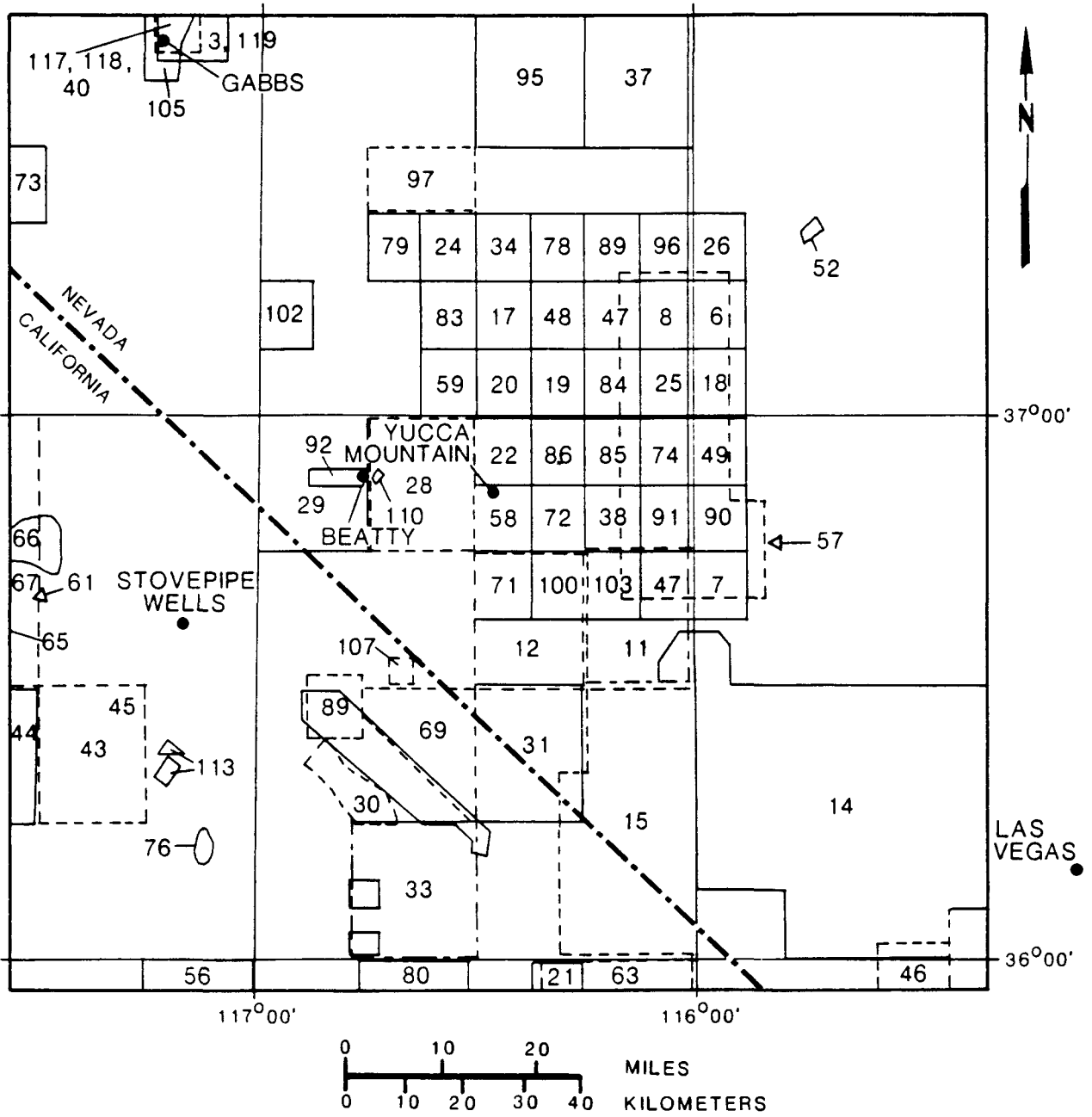

Figure 8.3.1.17-7. Index map showing published geologic map coverage at scales of 1:63,630 and larger. Map areas (numbered) referenced in Fouty (1984)

CONSULTATION DRAFT

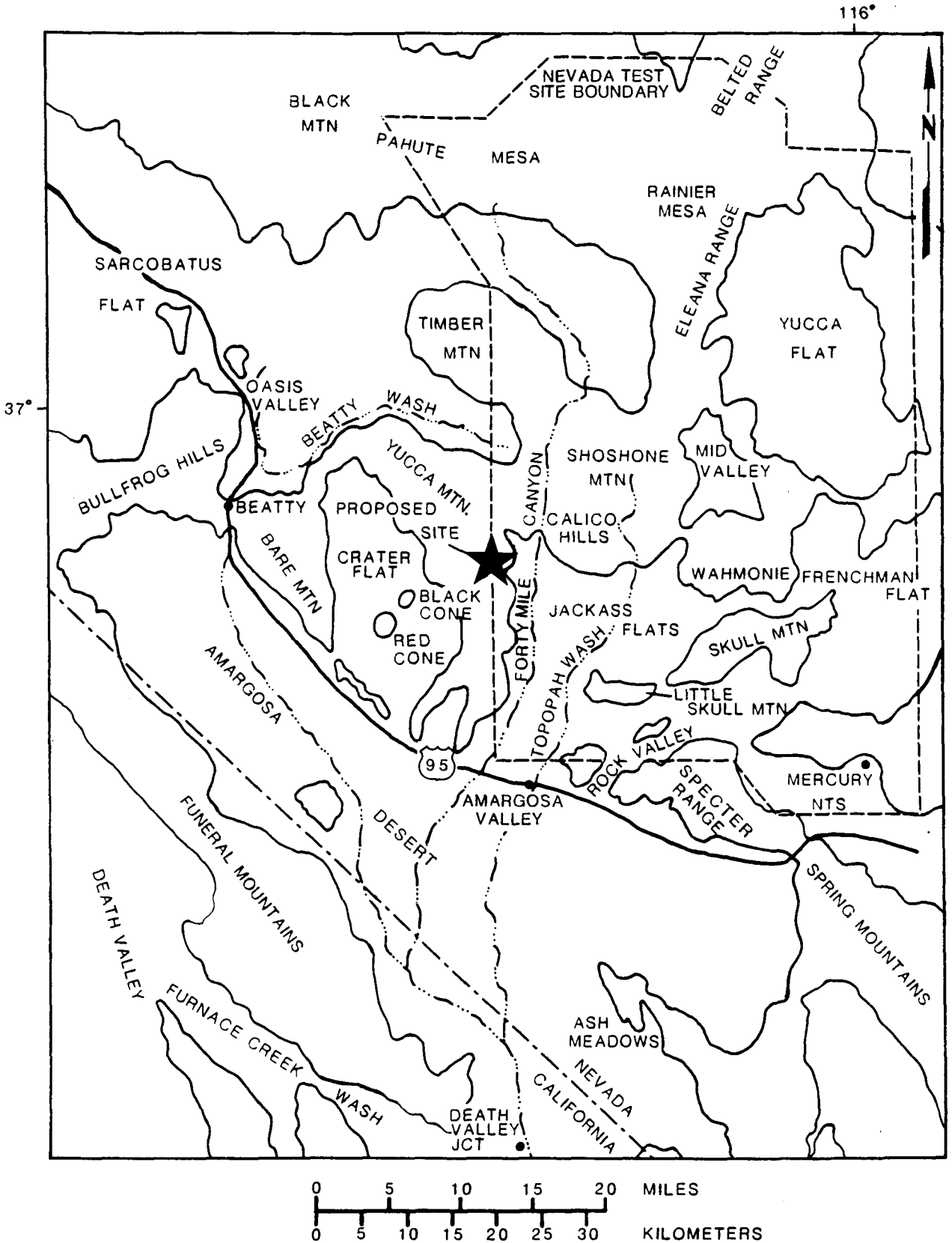

Figure 8.3.1.17-8. General localities map.

8.3.1.17-90

CONSULTATION DRAFT

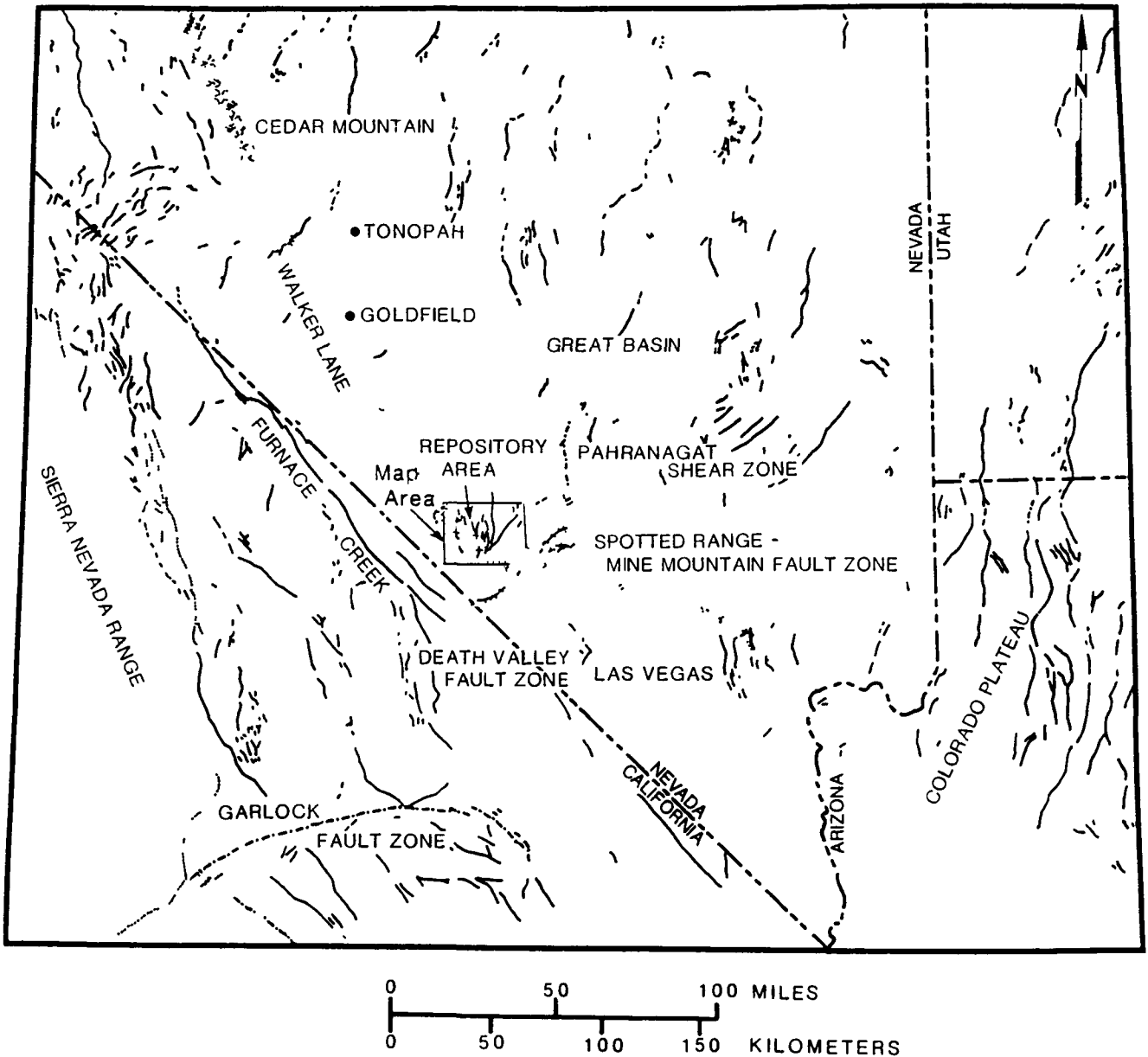

Figure 8.3.1.17-9. Regional structure map showing location of the repository area map areas of Figure 8 3 1 17-2 and 8 3 1 17-11, and major Quaternary structural features

CONSULTATION DRAFT

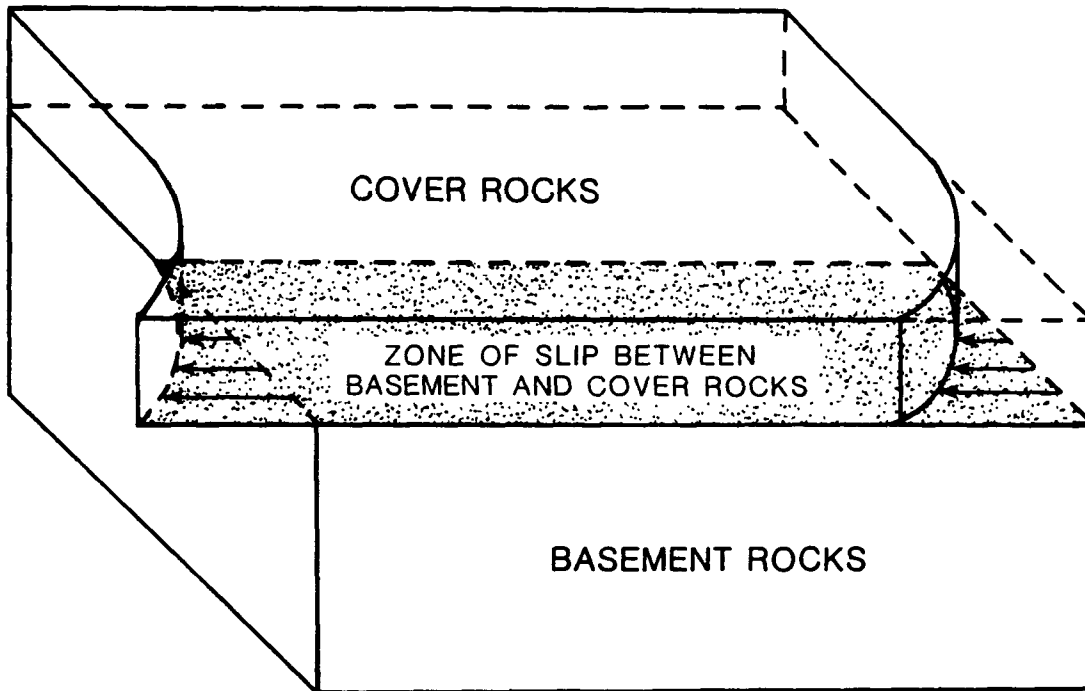
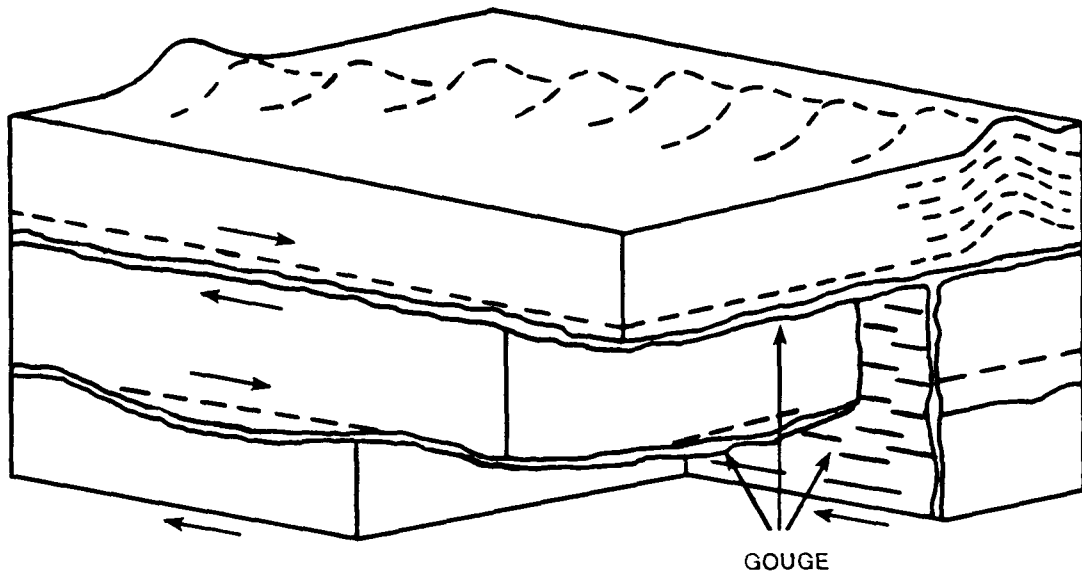

Figure 8.3.1.17-10. Idealized models of upper crustal deformation involving right-lateral shear on through-going wrench fault and displacement on overlying detachment fault, as postulated for Cedar Mountain area by Molinari (1984) and southern Nevada Test Site by Burchfiel (1965)

CONSULTATION DRAFT

connects with the Furnace Creek fault, rather than with other elements of the Walker Lane to the northwest (Burchfiel, 1965).

Northwest-trending lineaments and right-lateral strike-slip faults exposed at Yucca Mountain and vicinity could be surface expressions of the Walker Lane. These include faults at Yucca Wash (Carr, 1984), Drill Hole Wash (Spengler and Rosenbaum, 1980), and the Yucca-Frenchman shear zone (Carr, 1974). Quaternary movement on these faults has not been recognized. As shown in Section 1.4, current seismicity is not identified with these faults, and focal mechanisms of earthquakes within and proximal to the site do not show northwest-trending fault planes. This may suggest that this part of the Walker Lane has not been seismically active since records have been kept.

In addition to the change in orientation of basins and ranges that occurs within the Walker Belt, the structural grain of certain structural blocks within the belt is sharply deflected from the regional trend. These blocks appear to have been rotated about a vertical axis forming an oroflex (Albers, 1967). Recent paleomagnetic and structural studies of Miocene ash flows suggest that Yucca Mountain has been bent into an oroflex since middle Miocene time, with the southern part of the mountain apparently rotated clockwise up to 30 degrees relative to the northern part (Scott and Rosenbaum, 1986); thus, it appears to have been deformed within a right-lateral couple, as have other parts of the Walker Belt.

In summary, two potential seismic source zones within a 100-km radius of the site are the Walker Lane, whose postulated subsurface continuation passes below the Miocene volcanic and volcanoclastic rocks of the NTS (Ekren, 1968; Burchfiel, 1965), and the Death Valley-Furnace Creek fault zone, which at its closest approach lies 52 km southwest of the site. Both of these structures are right-lateral wrench zones. The Death Valley-Furnace Creek fault zone offsets Holocene deposits in its central and southern segments, and is long enough to generate a great earthquake, hence is thought to be the most significant potential source of ground shaking outside a 50-km radius of the site.

The Walker Lane is approximately 600 km long, shows substantial (25 to 30 km) post-Miocene right-lateral displacement, and is seismically active in its northern and central parts. The Cedar Mountain earthquake of 1932 ($M = 7.2$ to 7.3) was located on the central part of the Walker Lane, approximately 175 km northwest of the site. Post-Miocene right-lateral displacement is not obvious on the part of the Walker Lane within 100 km of the site. Thus, either the southern part of the Walker Lane is pre-Quaternary in age, Quaternary movement has not been translated through the overlying Miocene volcanic rocks of Yucca Mountain and the NTS, or Quaternary movement has occurred but has not yet been recognized.

Although the principal focus of this study is on the Walker Lane and the Death Valley-Furnace Creek fault zone, other potentially significant Quaternary faults within a 100-km radius of the site will be identified through a search of the existing data, supplemented by examination of air photos and ground reconnaissance. Features that could be significant sources of ground motion include the Beatty scarp (if it is a fault) and the Bare Mountain fault zone.

CONSULTATION DRAFT

Because of the geologic investigations at and near the site area, the density of known Quaternary faults in that area (Figure 8.3.1.17-11) now substantially exceeds that of much of the surrounding region. (The site area is defined here as the rectangular 237 km² (91 mi²) area encompassing the central Yucca Mountain block and its structural and physiographic boundaries (Fortymile Wash, Yucca Wash, Solitario Canyon, and the Stagecoach Road fault.) Mapping of Quaternary faults and surficial deposits within the Beatty 1:100,000 quadrangle should clarify whether this concentration is real or is simply an artifact of the focusing of effort on the Yucca Mountain area. In any instance, to evaluate the likelihood of future faulting within the site area (an objective of Study 8.3.1.17.4.6--Quaternary faulting within the site area) the boundaries of the structural domain, including Yucca Mountain, within which Quaternary faults have a uniform density and common genesis will be defined. Structural domains within 100 km of Yucca Mountain will be delineated on the basis of regional variation in fracture density and fracture pattern as observed on Landsat V Thematic Mapper imagery. The Landsat V imagery will also provide information on distribution of desert varnish, which is related to the presence of stable geomorphic surfaces (whose definition is an objective of Study 8.3.1.17.4.9--tectonic geomorphology of the Yucca Mountain region).

Activities planned for this study are (1) an evaluation of crustal structure and subsurface expression of Quaternary faults in an east-west transect crossing the Furnace Creek fault zone, Yucca Mountain, and the Walker Lane; (2) an evaluation of surface expression of Quaternary faults within a 100-km radius of the site (Yucca Mountain); (3) an evaluation of the Cedar Mountain earthquake of 1932 and its bearing on wrench tectonics of the Walker Lane; (4) an evaluation of the Bare Mountain fault; and (5) an evaluation of structural domains and characterization of the Yucca Mountain region with respect to regional patterns of faults and fractures.

8.3.1.17.4.3.1 Activity: Conduct and evaluate deep geophysical surveys in an east-west transect crossing the Furnace Creek fault zone, Yucca Mountain, and the Walker Lane

Objectives

The objectives of this activity are

1. To help identify and locate potentially significant seismic source zones, including possible through-going extensions of the Walker Lane, beneath the Oligocene-Miocene cover of the Yucca Mountain area; to determine the width and subsurface geometry of such extensions and of the Furnace Creek fault zone and the relation of these features to detachment faults and to Quaternary faults; and to evaluate the postulated incipient rift zone at Crater Flat.
2. To characterize the crustal velocity structure and define lateral inhomogeneities in that structure in the Yucca Mountain area.

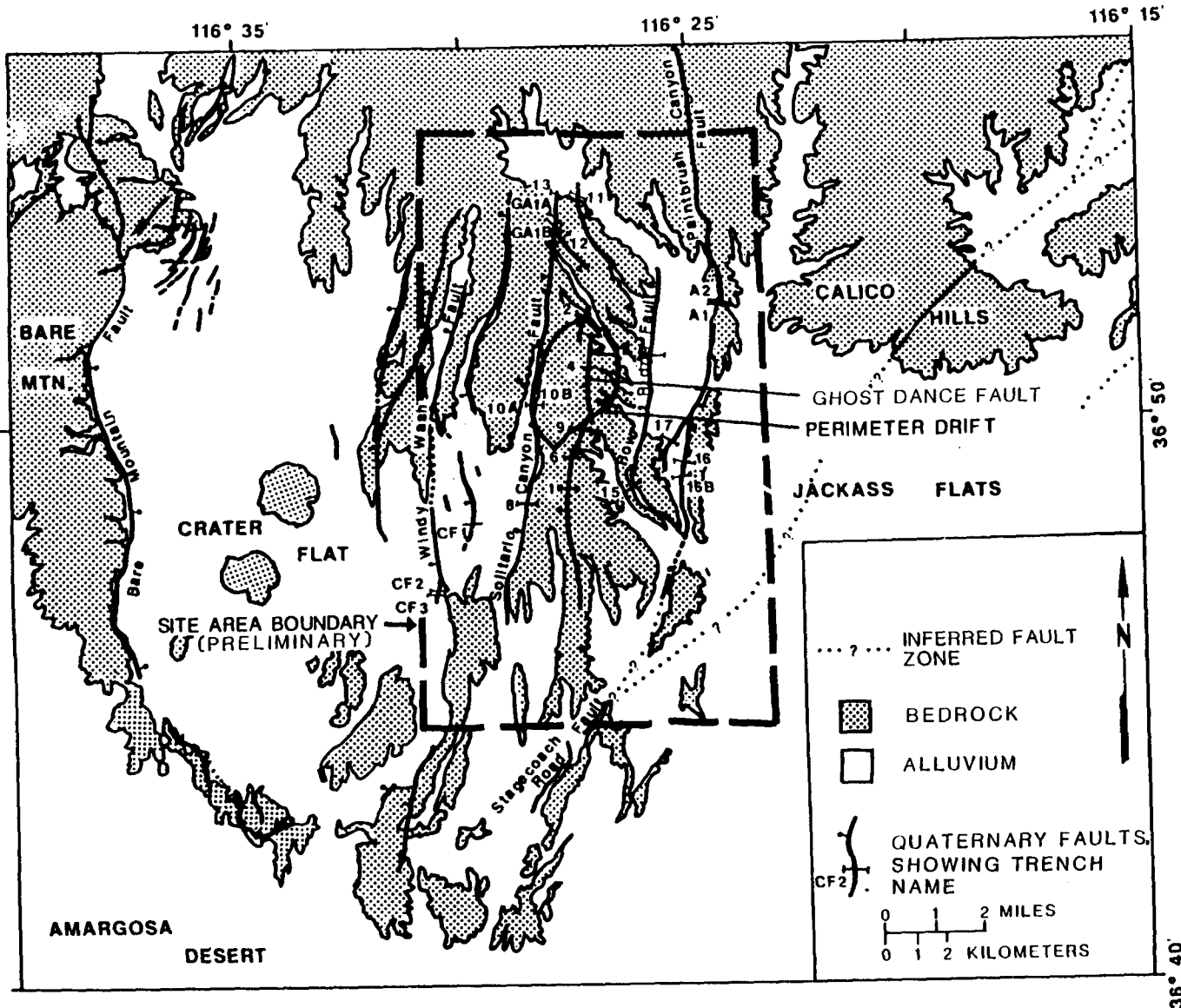

Figure 8.3.1.17-11 Generalized Quaternary fault map of Yucca Mountain and vicinity, showing trench locations (CF1, 1, GA1A, ect.) and site area boundary.

CONSULTATION DRAFT

3. To trace the 5- and 10-s events found on Death Valley Consortium for Continental Reflection Profiling (COCORP) profiles through the Yucca Mountain region and, if possible, to trace reflections from the upper and lower carbonate aquifers, the Precambrian-Cambrian Pahrump Group and Noonday Dolomite, and the Proterozoic basement across the Furnace Creek fault and through the area of the projected northwest continuation in the subsurface of the Las Vegas Valley shear zone.
4. To identify differences in mass caused by variation in source lithology in the upper few kilometers of the crust, and correlate those sources with reflections obtained in the seismic reflection survey, or with conductivity features obtained in the magnetotelluric survey.
5. To identify differences in magnetic field caused by sources in the upper few kilometers of the crust and correlate those sources with reflections obtained in the seismic reflection survey, or with conductivity features obtained in the magnetotelluric survey.
6. To characterize the conductivity structure of the crust in the Yucca Mountain region, focusing in particular on the conductivity signature of the Walker Lane and Walker Belt, and if possible, tracing the signature into the subsurface of conductive units such as the Eleana Formation or nonconductive units such as the lineated and mylonitized gneisses (lower plate?) of the northern Amargosa Desert, and to correlate these features or their offsets with Quaternary faults.

Parameters

The parameters for this activity are

1. Lateral discontinuities in seismic refraction profiles.
2. Lateral discontinuities in seismic reflection profiles.
3. Gravity anomalies.
4. Magnetic anomalies.
5. Lateral and vertical discontinuities in crustal conductivity structure.

Description

Geophysical methods may be useful for locating possible subsurface extensions of surface or near-surface geologic structures of interest. At Yucca Mountain, this includes the subsurface geometry of postulated detachment faults, interconnections between northeast-trending and north-trending faults, and possible through going extensions of the Walker Lane beneath the Oligocene-Miocene cover.

Proposed geophysical studies are summarized in Tables 8.3.1.17-7 and -8. As indicated in the tables, a variety of geophysical studies are planned at

Table 8.3.1.17-7. Summary of geophysical studies in preclosure and postclosure tectonics (Sections 8.3.1.17 and 8.3.1.8) (page 1 of 5)

Method	Activity	Location	Scope	Decision points	Comments
SEISMOLOGY					
Deep refraction	8.3.1.17.4.3.1	E-W Transect Indian Springs-Stovepipe Wells (Figure 8.3.1.17-12)	Reversed profiles and cross-profiles, shot-points 8 to 20 km spacing	None	Existing surveys shown in Figure 8.3.1.17 12. See Pankratz (1982), Mooney et al., (1982), Hoffman and Mooney (1983), Hoover et al. (1982), Monfort and Evans (1982), and Sutton (1984).
Shallow (bison) refraction and shear wave refraction and reflection	8.3.1.17.4.4.1 and others	Quaternary faults, Yucca Mountain and vicinity	250 to 500 m traverses, portable instruments sledgehammer energy source. Shear wave method uses 12 (or more) geophones, 3 m spacing	Number and location to be decided on the basis of geological and geophysical mapping	Maximum depth of penetration 100 m. Used to detect offset in surficial deposits. Shear wave method capable of detecting 30 cm offset.
Evaluation of proposed deep reflection survey	8.3.1.17.4.3.1	Proposed survey crosses Yucca Mountain and Crater Flat; 15 km test line to be located south of Amargosa Valley or southwest of Beatty	To be determined	Decision to proceed (DTP) after evaluation of preliminary tests (15 km reconnaissance line) and peer review	COCORP ^a survey extending northward into southern Death Valley produced marginal quality data, although data in the upper one second are locally good. Six second reflections were imaged with local continuity. See de Voogd et al. (1986).
Intermediate reflection and intermediate refraction	8.3.1.17.4.7.1	Site-controlled area, Yucca Mountain (Figure 8.3.1.17-11)	Evaluate previous results, assess potential for application of this method to Yucca Mountain, plan new application if appropriate	None	This is a planning activity only. Previous reflection survey using vibroseis at Yucca Mountain failed (McGovern, 1983). More recent surveys using air gun at Mid Valley produced useful results (McArthur and Burkhard, 1986). See also Hoover et al. (1982).
Shallow (mini-sosie) reflection	8.3.1.17.4.7.8 and others	Yucca Mountain, Crater Flat, Jackass Flats (Figure 8.3.1.4-8)	7 to 15 profiles, 1 to 5 km in long, hand carried instruments. Energy from battery of hand-operated tampers	DTP after evaluation of two preliminary profiles	Maximum depth of penetration 1 km. Used to map shallow structural and stratigraphic features.

8.3.1.17-97

CONSULTATION DRAFT

Table 8.3.1 17-7. Summary of geophysical studies in preclosure and postclosure tectonics (Sections 8.3.1.17 and 8.3.1.8) (page 2 of 5)

Meth d	Activity	Location	Scope	Decision points	Comments
GRAVITY INVESTIGATIONS					
Regional maps	8 3 1 17 4 12 1	Yucca Mountain and vicinity	Beatty 1 100,000 quad range, Pahute Mesa 1 100,000 quadrangle, Nevada Test Site 1 100,000 map area, Yucca Mountain 1 48,000 map area	None	Field work complete, compilation complete, preliminary drafts available See Snyder and Oliver (1981), Kane et al (1981), Ponce (1981), Ponce and Oliver (1981), Hoover et al (1982), Ponce and Hanna (1982), Jansma et al (1982), Ponce (1984), and Snyder and Carr (1984)
Site area map	8 3 1 17 4 7 2	Yucca Mountain (Figure 8 3 1 17 11)	1 24,000 map of site and vicinity, 200 ft spacing of stations along E-W lines spaced 500 ft apart (where topography permits)	None	Will require additional 7,500 stations Useful for establishing stratigraphic variability of repository host rock and fault location and offset See Snyder (1981), Snyder and Carr (1982), Jansma et al (1982), Kane et al (1982), Ponce et al (1985)
Detailed surveys, deep reflection profiles	8 3 1 17 4 3 1	Stovepipe Wells, Yucca Mountain, Indian Springs Precise location to be determined	Gravity determinations along profiles at 500 ft spacing	DTP only if seismic surveys run	Assists interpretation of seismic results
MAGNETIC METHODS					
Regional aeromagnetic maps	8 3 1 17 4 12 1	Yucca Mountain and vicinity	Beatty, Pahute Mesa, Indian Springs-, and Pahrangat 1 100,000 quadrangles to be compiled from existing surveys	None	Field investigations complete, compilation 80% (?) complete See Kane et al (1981), Hoover et al (1982), Ponce and Hanna (1982), Kane and Bracken (1983), U S Geological Survey (1984b), Ponce (1984)
Site area aeromagnetic map	8 3 1 17 4 7 3	Yucca Mountain (Figure 8 3 1 17 11)	1 12,000 scale map of site and vicinity, continuous aeromagnetic survey along E W flight lines spaced 1/16 mile apart	None	1 62,500 scale map complete (U S Geological Survey, 1984a), See also Jansma et al (1982), Bath et al (1982), Kane et al (1982), Kane and Bracken (1983), and Bath and Jahren (1984)

8.3.1.17-98

CONSULTATION DRAFT

Table 8.3.1.17-7. Summary of geophysical studies in preclosure and postclosure tectonics (Sections 8.3.1.17 and 8.3.1.8) (page 3 of 5)

Method	Activity	Location	Scope	Decision points	Comments
Ground magnetic survey, deep reflection profiles and shallow reflection profiles	8 3 1 17 4 3 1	Stovepipe Wells, Yucca Mountain, Indian Springs Precise location to be determined	Magnetic determinations along profiles at 10 to 20 ft spacing where accessible by truck, 50 to 100 ft spacing elsewhere	DTP only if seismic surveys run	Assists interpretation of seismic results
Site ground magnetic surveys	8 3 1 17 4 7 4	Yucca Mountain (Figure 8 3 1 4 11)	Ground magnetic surveys at (1) known and inferred structures, (2) vicinity of drill-holes (3) vicinity of shaft and surface facilities, (4) anomalies detected in site aeromagnetic map (described previously) Surveys to be semi-continuous (10 to 20 ft spacing)	Number and location to be determined through evaluation of geologic and geophysical mapping	Primary purpose is to locate concealed extensions of faults See Bath and Jahren (1984, 1985), Scott et al (1984)
Curie isotherm	8 3 1 8 5 2 1	Yucca Mountain Region	Analysis of existing regional aeromagnetic data	None	Purpose is to map configuration of Curie isothermal surface, and to compare areas of shallow isotherms with areas of high heat flow and recent volcanism See Connard et al (1983)
ELECTRICAL METHODS					
Regional magnetotelluric (MT)	8 3 1 17 4 3 1	Yucca Mountain, Crater Flat, Jackass Flats, Amargosa Desert, Death Valley (Figure 8 3 1 17 8)	Detailed survey with stations at 3 to 5 km spacing of Yucca Mountain, Crater Flat, and northern Amargosa Desert, reconnaissance survey with stations at 10-km spacing in remainder of area	None	Previous survey by Furgerson (1982) shows mappable conductivity contrasts in 1-15 km depth range See also Kauahikaua (1981), Hoover et al. (1982)

CONSULTATION DRAFT

8.3.1.17-99

Table 8.3.1.17-7. Summary of geophysical studies in preclosure and postclosure tectonics (Sections 8.3.1.17 and 8.3.1.8) (page 4 of 5)

Method	Activity	Location	Scope	Decision points	Comments
Surface geoelectric investigations (Airborne electromagnetic slingram, very low frequency, dc resistivity, electromagnetic soundings, tensor audio magnetotellurics, and telluric profiling)	8.3.1.17 4.7.5	Yucca Mountain	Assess potential for application of these methods, evaluate previous results, plan new applications if appropriate, conduct prototype tests	DTP with full scale application of selected methods only if warranted by results of prototype testing	Applied to structural and stratigraphic problems at the site by Flanigan (1981), Smith and Ross (1982), Fitterman (1982), Hoover et al., (1982), Senterfit et al., (1982), Scott et al. (1984), Frischknecht and Raab (1984). Other studies in region include Zablocki (1979), Anderson (1982), Smith et al., (1981), Greenhaus and Zablocki (1982).
RADIOMETRIC AND REMOTE SENSING METHODS					
Surface and airborne gamma ray investigations	8.3.1.17.4.7 6	Yucca Mountain	Assess potential for application of these methods with preliminary survey over known faults using static ground measurements	DTP with full-scale application of airborne methods only if warranted by results of preliminary survey	Could detect percolation of radon through fault zones.
Thermal infrared investigations	8.3.1.17.4.7.7	Yucca Mountain	Assess potential for application of aircraft and satellite thermal infrared imagery in mapping of fracture network	DTP based on evaluation of cost and expected results	Method depends on detection of surface temperature variation, which is largely dependent on soil moisture content, which in turn is in part related to infiltration along fractures.
Thematic Mapper Satellite Imagery	8.3.1 17.4.3 5	Yucca Mountain and vicinity	Tapes of the four Thematic Mapper V scenes encompassing the Yucca Mountain Region (Beatty, Indian Springs, Pahute Mesa, and Pahrangat Range 1:100,000 quadrangles) to be used to produce spectral and spectral ratio maps.	None	Used to define structural domains, areas of well-developed desert varnish, and areas of hydrothermal alteration.

CONSULTATION DRAFT

8.3.1.17-100

Table 8.3.1.17-7. Summary of geophysical studies in preclosure and postclosure tectonics (Sections 8.3.1.17 and 8.3.1.8) (page 5 of 5)

Method	Activity	Location	Scope	Decision points	Comments
Thematic Mapper Satellite Imagery (continued)			from which areas containing distinctive patterns of lineations will be delineated		
PALEOMAGNETISM					
Region	8 3 1 17 4 3 2	Yucca Mountain, Little Skull Mountain, Crater Flat, Skull Mountain, southern Yucca Mountain, eastern Yucca Flat	5 to 6 sites at Yucca Mountain will be sampled. If useful results are obtained, other sites as listed may be sampled	DTP only if useful results obtained at Yucca Mountain, and if suitable strata are present	Preliminary results at Yucca Mountain suggest 30° rotation (Scott and Rosenbaum, 1986)

^aCOCORP = Consortium for Continental Reflection Profiling

Table 8.3.1.17-8. Summary of other geophysical studies contributing to preclosure and postclosure tectonics (Sections 8.3.1.17 and 8.3.1.8) (page 1 of 3)

Method	Activity	Location	Scope	Decision points	Comments
SEISMOLOGY					
Vertical seismic profiling	8.3.1.4.2.2.5	Repository block and vicinity	15-25 geotomographic profiles, 0.2 to 2 km in length, cross-hole and surface down-hole surveys. Directional shear- and compression-energy sources	Decision to proceed (DTP) after prototype of feasibility DTP after calibration in shaft and drifts	Used to map 3-dimensional network of rock mass fractures. 20 m pixel geometry.
Shallow seismic refraction	8.3.1.14.2.3.3	Vicinity of surface facilities	TBD ^a	None	Will provide data for modeling soil-structure interaction and local site effects on vibratory ground motion
PALEOMAGNETISM					
Site	8.3.1.4.2.1.5	Yucca Mountain	Orient drill core as it becomes available. Establish reference orientation through study of outcrop samples. Determine magnetic character of outcrop samples to aid in interpretation of aeromagnetic data.	None	See Rosenbaum (1983), Rosenbaum and Rivers (1985), Rosenbaum and Snyder (1985), Rosenbaum (1985).
BOREHOLE GEOPHYSICAL METHODS					
Geophysical logging					
Borehole gravimetry	8.3.1.4.2.1.3	Yucca Mountain	15 water-table drill-holes, existing deep holes that can be made available, and all new holes that reach the base of the Topopah Spring Member	None	Already have data in drillholes H-1, P-1, G-1, G-3, and G-4. Data will be used to model structure in the immediate vicinity of each borehole, to study lithophysal zones, and to model the Paleozoic surface beneath Yucca Mountain. See Robbins et al. (1982), Healey et al. (1984), and Healey et al. (1986).
Borehole magnetic logs	8.3.1.4.2.1.3	Yucca Mountain	15 water-table drill-holes, and new drill-holes prior to casing operations	None	Used to determine mappable magnetic events for studying structural integrity of Yucca Mountain, and to supplement paleomagnetic and lithophysal studies. See Hagstrum et al. (1980).

8.3.1.17-102

CONSULTATION DRAFT

Table 8.3.1.17-8. Summary of other geophysical studies contributing to preclosure and postclosure tectonics (Sections 8.3.1.17 and 8.3.1.8) (page 2 of 3)

Method	Activity	Location	Scope	Decision points	Comments
Induced potential logs	8 3 1 4 2 1 3	Yucca Mountain	Test in one or two drillholes	Evaluate for effectiveness after 1 or 2 drillholes	Feasibility study to determine if the method can be used to map seolitized rock
Contractor logs	8 3 1 4 2 1 1	Yucca Mountain	All existing unlogged drillholes, all new holes, and relog selected holes	None	To obtain parameters for hydrologic, geologic, and geophysical models, and to determine uniformity and lateral distribution of rock properties within the stratigraphic units. Refer to Spengler et al (1979), Maldonado et al (1979), Daniels and Scott (1981), Hagstrum et al (1980), Daniels et al (1981), Muller (1982), Muller and Kibler (1983), Muller and Kibler (1984), Spengler and Chornack (1984), Muller (1986), and Muller and Kibler (1986)
Borehole radar logs	8 3 1 4 2 1 3	Yucca Mountain	Drillholes that penetrate the base of the Topopah Spring Member	Evaluate for effectiveness after 1 or 2 drillholes	Primarily used for fracture detection or to demonstrate the absence of fractures in the unsaturated zone
Acoustic televiewer logs and TV camera logs	8 3 1 4 2 1 3	Yucca Mountain	All Yucca Mountain drillholes	None	For fracture and fault zone detection, and stratigraphic and lithologic correlation. See Healy et al (1984), Stock et al (1984), Stock and Healy (1984), Stock et al (1985)
Large spacing electromagnetic and resistivity logs	8 3 1 4 2 1 3	Yucca Mountain	Selected drillholes	After evaluation of surface and borehole data	To determine accurate large volume in situ values for studying fracture and lithophysical zones, and for interpreting anomalies detected with surface and borehole data
BOREHOLE TO SURFACE METHODS					
Resistivity and electromagnetic methods	8 3 1 4 2 1 3	Yucca Mountain	Selected drillholes	After evaluation of surface and borehole data	For fracture studies in the unsaturated zone, to obtain detailed structure in areas of anomalous surface geophysical data and in critical locations such as the shaft site and surface facilities locations, and to verify projected faults at critical locations. See Daniels and Scott (1981)

CONSULTATION DRAFT

8.3.1.17-103

Table 8.3.1.17-8. Summary of other geophysical studies contributing to preclosure and postclosure tectonics (Sections 8.3.1.17 and 8.3.1.8) (page 3 of 3)

Method	Activity	Location	Scope	Decision points	Comments
High resolution P and S wave seismic	8.3.1.4.2.1.3	Yucca Mountain	Selected drillholes	After evaluation of surface and borehole surveys	Same as previously, and to obtain parameters for designing effective deeper-penetrating seismic surveys.
Surface-to-hole seismic refraction	8.3.1.4.2.1.3	Yucca Mountain	Selected drillholes	After evaluation of surface and borehole surveys	Same as two previous, and for critical fault location and bed tracing.
Up-hole and down-hole seismic	8.3.1.14.2.3.3	Vicinity of surface facilities	TBD	After evaluation of shallow seismic refraction survey	Will provide data for modeling soil-structure interaction and local site effects on vibratory ground motion
BOREHOLE TO BOREHOLE METHODS					
Zone hole to borehole methods	8.3.1.4.2.2.5	Yucca Mountain close-spaced holes for hydrologic testing and for surface facilities studies	Selected drillholes	None	Geotomography to map fractures and demonstrate mappability of features that intersect the drillholes using resistivity, electromagnetic radar, and high resolution P and S seismic (Yo Yo) methods.
Cross-hole seismic	8.3.1.14.2.3.3	Vicinity of surface facilities	TBD	After evaluation of shallow seismic refraction survey	Will provide data for modeling soil-structure interaction and local site effects on vibratory ground motion
PETROPHYSICS					
Petrophysics	8.3.1.4.2.1.4	Yucca Mountain	Selected core from cored drillholes	None	To verify geophysical log accuracy, calibrate computed logs, determine properties that are not or cannot be measured in situ, and to model and interpret surface geophysical studies

^aTBD = to be determined

CONSULTATION DRAFT

different locations and scales, to address a number of questions. Planned studies include deep and shallow seismic refraction; deep, intermediate, and shallow seismic reflection; gravity and magnetic surveys of the region and the site; gravity surveys coincident with the deep-seismic reflection surveys; magnetic surveys coincident with the deep and shallow reflection surveys; electrical conductivity surveys; radiometric and remote-sensing investigations; and paleomagnetic investigations.

In general, the shallow studies will focus on individual geologic structures, such as a specific Quaternary fault, and the deep studies will examine regional structures that may play a part in Quaternary tectonic processes in the southern Great Basin.

The geophysical studies will be conducted under Activity 8.3.1.17.4.3.1, described in this section, and in Study 8.3.1.17.4.7. The studies in Activity 8.3.1.17.4.3.1 are directed at deep, regional geologic features, whereas Study 8.3.1.17.4.7 addresses the subsurface geometry and possible concealed extensions of specific Quaternary faults at and near Yucca Mountain through intermediate- and shallow-depth geophysical surveys.

The geophysics program is designed to obtain different types of data that, when analyzed as a whole, will aid in the interpretation of recorded seismicity and surface geologic data. The simultaneous interpretation of geophysical, seismological and geologic data may help resolve such issues as the width, dip, and geometry of north-trending Quaternary normal faults at and near the site and whether there are subsurface structures that are related to known Quaternary structures.

Planned locations of geophysical surveys, as described below, may change. Several surveys involve feasibility tests and decision points before implementation. Several also require additional analysis of potential contributions to site characterization. Final plans and changes will be reported in SCP progress reports and study plans.

The seismic reflection studies will be preceded by a preliminary test to determine if the results of the technique will be useful for evaluating subsurface structure in the Yucca Mountain region. A peer-review panel will review the initial results and will determine if further work is warranted.

A detailed description of the planned geophysical studies follows.

Seismic refraction methods have been used to characterize the general velocity structure of the upper crust in the Yucca Mountain area (Figure 8.3.1.17-12), and to establish the location and nature of major discontinuities in that velocity structure (Hoffman and Mooney, 1983). When used in conjunction with gravity and magnetic surveys, the method is useful in limiting applicable structural models (Snyder and Carr, 1984), although resolving power is low. The refraction survey will include an east-west profile spanning the transect, and three shorter cross-profiles (Figure 8.3.1.17-12).

Seismic reflection methods are used where clear resolution of upper crustal stratigraphy and structure is required. A seismic reflection survey

CONSULTATION DRAFT

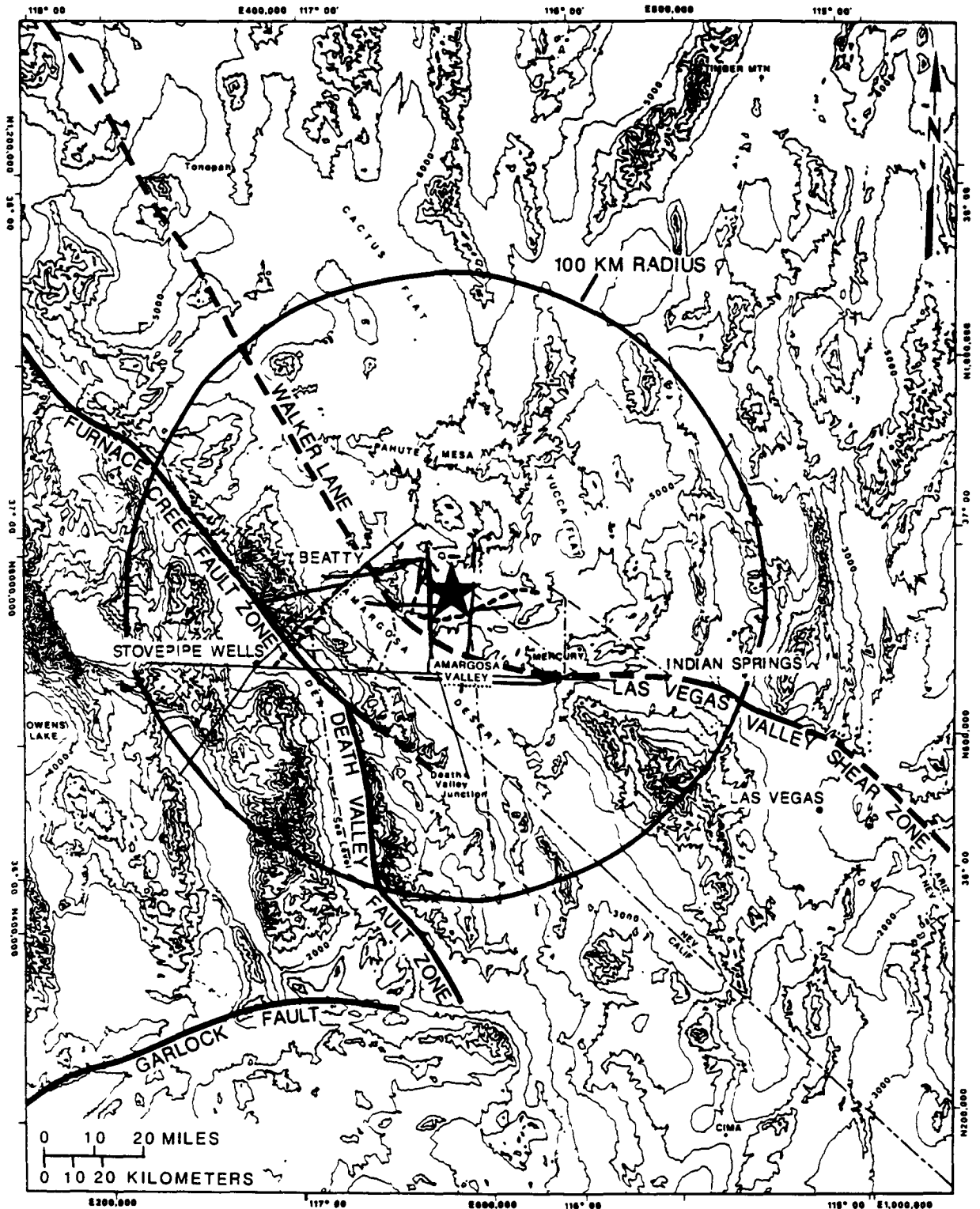

- SEISMIC REFRACTION (COMPLETED)
- SEISMIC REFRACTION TRANSECTS (TENTATIVE)
- - - - MAGNETOTELLURIC TRAVERSES WITH STATIONS (COMPLETED)
- - - - FUTURE MAGNETOTELLURIC TRAVERSES
- SEISMIC REFLECTION TESTING LINES

★ YUCCA MOUNTAIN SITE

Figure 8.3.1.17-12. Location of seismic refraction and magnetotelluric sounding traverses.

CONSULTATION DRAFT

across the northern Walker Lane successfully imaged strands of northwest-trending faults within the zone (Knuepfer et al., 1987). The Walker Lane in that area appears to be the surface expression of a southwest dipping (45°) fault that soles into a midcrustal detachment (Knuepfer et al., 1987). Analogous features in the Yucca Mountain region include major structures such as a six-second (two-way sonic travel time) reflection in Death Valley that may be interpreted as a mid-crustal brittle-ductile transition zone (de Voogd et al., 1986), the Furnace Creek fault zone and the Walker Lane, and the mylonitic detachment-bounded upper surface of the Precambrian, exposed in the northern Amargosa Desert. Other potential reflectors in the Yucca Mountain region include the upper and lower carbonate aquifers within the Paleozoic sequence (Winograd and Thordarson, 1975), and the Miocene-Paleozoic contact.

If good quality reflections can be obtained in this area, then high-resolution reflection seismology, supplemented by gravity and magnetic surveys, could define the width, continuity, and depth of these features, thus constraining the location and character of potential sources of ground motion and rupture within 100 km of the site. This possibility will be evaluated through testing of a preliminary seismic reflection survey.

Magnetotelluric (MT) soundings (Ferguson, 1982) in the Yucca Mountain region indicate the presence of substantial conductivity contrast between Precambrian crystalline rocks, Paleozoic aquifers and aquitards, argillaceous units of the Paleozoic such as the Eleana Formation, Miocene volcanic rocks, and Quaternary basin fill deposits. Ferguson's (1982) soundings are too widely spaced to permit reliable interpretation of structure. Additional soundings, planned as part of this study, should help constrain the location of fault zones, the identity of deep reflectors observed on the high-precision seismic reflection profiles, and in addition will help distinguish deep-seated bodies of molten rock.

The MT survey will include a detailed net with stations spaced at 3 to 5 km, and a reconnaissance net with stations spaced at 8 to 10 km. The detailed net will extend from Stovepipe Wells eastward to Mercury, Nevada, with additional offline stations in the northern Amargosa Desert and in Crater Flat. The reconnaissance net will include north-south lines designed to tie the Yucca Mountain area to the Consortium for Continental Reflection Profiling (COCORP) reflection surveys to the south. The MT survey and refraction survey will provide a gross characterization of crustal structure at low cost.

Seismic refraction survey (Death Valley-Beatty Junction-Sheep Range). Four seismic refraction profiles are tentatively planned. As presently conceived, a 160-km long east-west profile centered on Yucca Mountain will consist of two 80-km deployments, each using 120 instruments spaced at 0.7 to 1.0 km and recording seven 900- to 1,800-kg shots spaced at 8 to 20 km. Three cross-profiles, potentially including an 80-km profile extending southward from the northern end of Crater Flat, a 110-km profile extending southwestward from the northern end of Crater Flat, and a 70-km northwest-southeast profile centered on Stovepipe Wells, will consist of one to two deployments of 120 instruments recording two to three 900- to 1800-kg shots per deployment. Field work for the central and eastern part of the survey is currently under way, and completion is planned in 1987 or early 1988. The

full extent of the survey will be determined after further consideration of the applicability of the expected results to Project needs.

Evaluation of proposed deep seismic reflection survey. A proposal to conduct a seismic reflection survey crossing Yucca Mountain and possibly extending across the Furnace Creek fault and the Walker Lane will be evaluated through preliminary testing and peer review.

The preliminary test will consist of a field survey of one line at a location to be determined, 15 km long, plus noise tests. The preliminary survey will use 10-km spreads, 24 geophones per group, 50-m group interval, 240 groups per spread, Vibroseis energy source, 100-m vibrator interval, 54,000-kg minimum peak vibrator force, and 240 channel floating-point digital recording. This configuration will be varied to optimize shallow and midcrustal reflections. Results of the preliminary tests and the design, scope, and potential application of the proposed survey to NNWSI Project needs will be evaluated by a panel convened for that purpose. Two alternative locations for the test line have been proposed, including (1) an east-west line located in the Amargosa Valley, approximately 5 km south of the town of Amargosa Valley, and (2) a northeast-trending line located about 10 km southwest of Beatty (Figure 8.3.1.17-12). Desired features of the proposed location include good access, low noise levels, and presence of alluvial cover.

Gravity survey (Stovepipe Wells-Death Valley-Beatty-Mercury-Indian Springs). If the proposed deep seismic reflection survey is implemented, a detailed gravity survey (using the La Costa Romberg gravimeter) will be conducted along a traverse coincident with the seismic reflection survey, possibly from Stovepipe Wells westward to Beatty, thence eastward to the northern Specter Range, thence northward to the northeast corner of the NTS through Yucca Flat. Gravity measurements will be made using portable devices, and surveying will use standard field methods.

Low-level magnetic survey (Stovepipe Wells-Death Valley-Beatty-Amargosa Valley-Indian Springs). If the proposed deep seismic reflection survey is implemented, a detailed low-level magnetic survey will be conducted along a traverse coincident with the seismic reflection survey, possibly from Stovepipe Wells westward to Beatty, thence eastward to the northern Specter Range, thence northward to the northeast corner of the NTS through Yucca Flat. Magnetometer measurements will be made using portable devices and surveying will use standard field methods.

Magnetotelluric survey (Stovepipe Wells-Death Valley-Beatty-Crater Flat-Mercury). Natural ambient magnetic fields and their induced electric fields at oscillations between 0.003 and 10 Hz will be measured using: high-precision voltage measurements across 150-m long electrode spreads; high-sensitivity induction coils; four-matched-channel, band-passed filtering with amplification; and real-time, floating-point, digital processing, and recording.

A 100-km long east-west line crossing the southern part of the NTS and the suspected subsurface extension of the Walker Lane (Las Vegas Valley shear zone) was surveyed in 1986 using close-spaced (3 to 6 km) field stations. The line included a 25-km traverse from Beatty, northeastward to northern

CONSULTATION DRAFT

Crater Flat, thence southwestward between Big Cone and Red Cone and across Bare Mountain to Highway 95, and thence eastward through the southern part of Yucca Mountain. The location and scope of additional traverse lines to be surveyed in 1988 and beyond will be based on application of expected results to Project needs.

Methods and technical procedures

The methods and technical procedures for Activity 8.3.1.17.4.3.1 are given in the following table.

Method	Technical procedure		Date
	Number	Title	
Seismic refraction survey (Death Valley-Beatty Junction-Sheep Range)	SP-08, R0	Seismic study of the tectonic environment	06 June 83
Seismic reflection survey (Stovepipe Wells-Beatty-Crater Flat-Yucca Mountain-Mercury-Indian Springs)	TBD ^a	Seismic reflection survey	TBD
Gravity survey (Stovepipe Wells-Death Valley-Beatty-Mercury-Indian Springs)	GPP-01, R1	Gravity measurement and data reduction	14 Jan 85
Low-level magnetic survey (Stovepipe Wells-Death Valley-Beatty-Amargosa Valley-Indian Springs)	TBD	Ground-based magnetic survey	TBD
Magnetotelluric survey (Stovepipe Wells-Death Valley-Beatty-Crater Flat-Mercury)	TBD	Magnetotelluric survey	TBD

^aTBD = to be determined.

8.3.1.17.4.3.2 Activity: Evaluate Quaternary faults within 100 km of Yucca Mountain

Objectives

The objectives of this activity are

1. To establish the abundance, distribution, and geographic orientation of known and suspected Quaternary faults within 100 km of the site.
2. To characterize the Quaternary and Holocene fault and fracture pattern within 100 km of the site and, if feasible, to relate that pattern to regionally important wrench fault systems, including the Walker Lane, the Death Valley-Furnace Creek fault zone, and the Mine Mountain-Pahranagat shear zone.
3. To characterize those Quaternary faults within 100 km of the site whose apparent length or recurrence rate indicate potential for future earthquakes of magnitude sufficient to affect design or performance of the waste facility.
4. To evaluate the recurrence history of that part of the Death Valley-Furnace Creek fault zone within 100 km of the site.
5. To identify fault scarps within 100 km of the site that may have been overlooked during conventional geologic field surveys and that may not have been apparent on conventional vertical aerial photography.
6. To verify the existence and age of scarps in the NTS area that were detected by low-sun-angle photogeologic interpretation.
7. To determine whether the Beatty scarp originated through tectonic or fluvial processes, or both; the nature of movement along the scarp, if tectonic; and the age of the scarp.
8. To ascertain the amount of post-middle Miocene horizontal rotation of bedrock alongside wrench faults and of bedrock suspected to be part of upper plate above subsurface wrench faults.

Parameters

The parameters of this activity are

1. Location, orientation, patterns, displacement, age and nature of Quaternary faults.
2. Fault scarp morphology and offset of Quaternary deposits.
3. Relative and absolute ages of Quaternary faults.
4. Abundance, dimensions, and orientations of Quaternary ruptures in the path of suspected subsurface wrench fault.

CONSULTATION DRAFT

5. Rotation of upper-plate rock in Yucca Mountain region as defined by deflections of paleomagnetic pole declinations.
6. Quaternary rate of fault movement.

Description

This activity will supply information on the nature and rate of faulting during the Quaternary within 100 km of the site, and identify and characterize any faults whose length or recurrence rate indicate potential for earthquakes of magnitude sufficient to affect design or performances of the waste facility. The abundance of mapped Quaternary faults within the NTS and vicinity is substantially greater than that elsewhere within any part of the Walker Lane southeast of Monte Cristo Valley. This contrast is at least in part an artifact of the lack of detailed mapping outside of the NTS (Figure 8.3.1.17-7).

As an initial step, a map of Quaternary faults within 100 km of the site will be compiled from published and unpublished sources. Vertical aerial photographs of the same area will then be examined and a photogeologic map prepared to illustrate suspected Quaternary scarps and faults. A selected proportion of the suspected faults will be verified and examined in the field, and the age and amount of movement estimated. The relation of the fault pattern to major regional structures, including the Walker Lane, will also be evaluated.

This map will define the source regions of major earthquakes that have produced surface faulting during late Quaternary time and, thus, provide an estimate of regional variations in the long-term rates of occurrence of large magnitude earthquakes.

Conventional vertical photography has been carried out for the Yucca Mountain area. To minimize the number of scarps that have been overlooked, low-sun-angle vertical photographs covering selected areas will be procured and photogeologic maps of suspected Quaternary scarps will be prepared and verified in the field.

As originally conceived by Gianella and Callaghan (1934b), the Walker Lane includes a curvilinear fault near Beatty, Nevada, defined by a prominent Quaternary scarp. If real, the fault could be a potential source of future ground motion at the site. However, the origin of the scarp is somewhat uncertain. It could have originated through fluvial processes, tectonic processes, or some combination of the two. To address this problem and the potential significance to design or performance issues, the scarp will be dated by a variety of methods, mapped, and its relation to faults at depth investigated.

The Walker Lane is commonly believed to be a zone of oroclinal or oroflexural bending because the structural grain of bedrock terranes curve abruptly as it intersects the zone forming a reverse S-shaped pattern indicating right-lateral wrenching. The structural grain in the vicinity of Yucca Mountain is obscured by the intersection of the Walker Lane with the left-lateral faults of the Mine Mountain-Spotted Range belt. To ascertain the degree to which oroflexural bending affects the Miocene volcanic cover at

CONSULTATION DRAFT

Yucca Mountain, paleomagnetic poles of selected ash flows will be measured at various locations from one side of the zone to the other. Comparison of the declination of these poles should provide a measure of the oroflexural bending since middle Miocene time.

Development of map of Quaternary faults within 100 km of the site (Las Vegas to Cedar Mountain). Known and suspected Quaternary faults within 100 km of the site will be identified from published and unpublished literature. A map showing the distribution of these faults will be compiled at a scale of 1:500,000. This subactivity is 50 percent complete. The duration of future work is three months.

Development of photogeologic map of Quaternary scarps within 100 km of the site. Quaternary scarps will be identified within 100 km of the site through photogeologic interpretation of existing 1:20,000- to 1:80,000-scale black-and-white, vertical aerial photographs. Photographs have been or will be obtained from Federal, State, and County archives. Study of potentially significant Quaternary faults will be augmented through analysis of low-sun-angle photographs. Scarps are to be compiled on 1:100,000- to 1:200,000-scale base maps. This effort is estimated to be 25 percent complete. The duration of future work is 1.5 years.

Field verification of Quaternary scarps within 100 km of the site. Scarps identified through photogeologic interpretation will be selectively examined in the field. The age of these scarps will be estimated from scarp morphology and bracketed by ages of units judged to be offset by or overlapping the scarps. Trenching will be done at scarps whose age would significantly constrain age of the Walker Lane or other large faults with potential for significant future ground motion. As yet, no scarps of this character have been identified.

Development of low-sun-angle photogeologic Quaternary scarp map (Yucca mountain area). Medium-scale vertical aerial photographs taken during periods of low-sun-angle will be procured for that part of the Walker Lane, proximal to Yucca Mountain, focusing on Jackass Flats, Crater Flat, and northern Amargosa Desert. Photographs will be interpreted using conventional procedures and scarps compiled on 1:100,000 scale base maps of the Yucca Mountain area. Estimated duration of this subactivity is one year.

Field verification of low-sun-angle photogeologic Quaternary scarps (Yucca Mountain area). Scarps that are identified through low-sun-angle photogeology will be examined in the field, their age estimated from scarp morphology and bracketed by ages of units judged to be offset by or overlapping the scarp. Trenching will be done at scarps whose age would significantly constrain age of faults with potential for significant future ground motion. The estimated duration of this subactivity is six months.

Mapping of Quaternary faults and deposits of the Beatty 1:100,000 quadrangle. Quaternary deposits and faults displacing those deposits will be mapped, using standard field methods, including annotating contacts on 1:20,000-scale aerial photographs, and compiling at 1:24,000 and 1:100,000 scales. Local stratigraphic type localities and sections will be established. Deposits will be dated using soil development, cation ratio (desert

CONSULTATION DRAFT

varnish), uranium-trend, and uranium-series, ash fingerprinting, as appropriate. Approximately 50 percent of the quadrangle has been completed. The estimated duration of future work is three years.

Evaluation of nature of Beatty scarp and relation to geologic boundary. The Beatty scarp and its southeastern extension was considered a segment of the Walker Lane by Gianella and Callahan (1934). The apparent length of the scarp, including its poorly defined southeastern extension, is 15 to 25 km. Detailed mapping of Quaternary deposits of the Beatty scarp will be supplemented by mapping of Quaternary datums in trenches crossing the scarp. Ages of the datums will be determined by analysis of soil development, uranium-series and uranium-trend analyses, radiocarbon dating, and cation-ratio (desert varnish) dating. Shallow seismic reflection (mini-sosie) and seismic refraction (Bison-type) surveys along traverses crossing the scarp and extending for 1 to 2 km (0.6 to 1.2 mi) to either side of the scarp will be performed to investigate the relation of the scarp to faults at depth. The duration of future work is three to six months.

Quaternary recurrence rate of the Death Valley-Furnace Creek fault zone. The Quaternary recurrence rate of this fault zone will be evaluated, using published and unpublished data, supplemented by limited field reconnaissance. The field investigation will focus on scarp morphology and age of surficial deposits intersected by or overlapping the fault. No excavations are planned. The estimated duration of this subactivity is 6 to 12 months.

Analysis of rotation (drag) of bedrock alongside or over suspected wrench faults based on rotation of paleomagnetic poles. Paleomagnetic orientations of samples collected from localities within the Tiva Canyon Member of the Paintbrush Tuff suggest that the Yucca Mountain area has been oroflexurally bent. Bending is clockwise and preliminary data suggest that the amount of bending relative to the north end of the mountain progressively increases through the central part and then increases sharply across the Stagecoach Road fault, reaching approximately 30 degrees at the south end (Scott and Rosenbaum, 1986). Bending could be related to right-lateral wrench faulting along the Walker Lane or, more speculatively, to detachment faulting in which a horizontal rotation of the detached plate is combined with dip-slip motion. The rotation occurred after 12.5 million years ago, the age of the Tiva Canyon Member.

This subactivity is designed to evaluate the preliminary results of paleomagnetic sampling at Yucca Mountain cited above through sampling of 5 to 6 additional localities to be selected from within the Tiva Canyon Member. If the rotation at Yucca Mountain is confirmed, then (1) the eastward extent of rotation and the possible influence of left-lateral faulting within the Mine Mountain-Spotted Range belt will be evaluated through sampling of 2 to 5 sites to be selected from within the Tiva Canyon Member at Little Skull Mountain or Skull Mountain, provided suitable localities are present, and (2) the age of rotation will be evaluated through sampling of late Miocene and Pliocene basalt flows in Jackass Flats and southeastern Crater Flat, provided suitable volcanic units are present.

Individual Miocene ash flows will be cored using hand-held drills at localities to be selected. Eight to ten oriented specimens will be obtained

CONSULTATION DRAFT

per site. After thermal demagnetization (Activity 8.3.1.4.1.3.1) the orientation of the magnetic pole for each specimen will be measured and corrected for inclination of the strata at the sample site. Comparison of declination from site-to-site will provide a measure of relative horizontal tectonic rotation. The estimated duration of future work is one to two years.

Methods and technical procedures

The methods and technical procedures for Activity 8.3.1.17.4.3.2 are given in the following table.

Method	Technical procedure		Date
	Number	Title	
	(NWM-USGS)		
Development of map of Quaternary faults within 100 km of the site	GP-01, RO	TBD	TBD
Development of photo-geologic map of Quaternary scarps within 100 km of the site	GP-01, RO TBD	TBD Photogeologic evaluation of faults using vertical aerial photographs	TBD
Field verification of Quaternary scarps within 100 km of the site	GP-01, RO GP-03, RO GP-04, RO		TBD
Development of low-sun-angle photogeologic Quaternary scarp map (Yucca Mountain area)	TBD	Photogeologic evaluation of faults using low-sun-angle photographs	TBD
Field verification of low-sun-angle photogeologic Quaternary scarps (Yucca Mountain area)	GP-01, RO GP-03, RO GP-04, RO		TBD

CONSULTATION DRAFT

Method	Technical procedure		Date	
	Number	Title		
Mapping of Quaternary geology of the eastern one-fourth of the Beatty 1:100,000 quadrangle	GP-01, RO		TBD	
	GP-03, RO			
	GP-04, RO			
	GP-17, RO			
	GCP-01, RO			
	GCP-02, RO			
	GCP-03, RO			
	GCP-04, RO			
	TBD	Cation ratio (desert varnish) dating		
TBD	Ash fingerprinting			
Mapping of Quaternary geology of the western one-fourth of the Beatty 1:100,000 quadrangle	GP-01, RO	Geologic mapping	01 Mar 83	
	GP-03, RO	Stratigraphic studies	01 Mar 83	
	GP-04, RO	Structural studies	01 Mar 83	
	GP-17, RO	Describing and sampling soils in the field	19 Feb 86	
	GCP-01, RO	Radiometric age data bank	15 June 81	
	GCP-02, RO	Labeling, identification, and control of samples for geochemistry and isotope chemistry	20 Jan 87	
	GCP-03, RO	Uranium-series dating	15 June 81	
	GCP-04, RO	Uranium-trend dating	15 June 81	
	TBD	Cation ratio (desert varnish) dating		
	TBD	Ash fingerprinting		
	Evaluation of nature of Beatty scarp and relation to geologic boundary	GP-01, RO	Geologic mapping	01 Mar 83
		GP-03, RO	Stratigraphic studies	01 Mar 83
		GP-04, RO	Structural studies	01 Mar 83
GP-07, RO		Geologic trenching studies	14 Aug 84	
GCP-01, RO		Radiometric age data bank	15 June 81	
GCP-02, RO		Labeling, identification, and control of samples for geochemistry and isotope chemistry	20 Jan 87	

CONSULTATION DRAFT

Method	Technical procedure		Date
	Number	Title	
	GCP-03, RO	Uranium-series dating	15 June 81
	GCP-04, RO	Uranium trend dating	15 June 81
	TBD	Radiocarbon dating	
	TBD	Cation ratio (desert varnish) dating	
	TBD	Shallow seismic reflection and refraction surveys	
Quaternary recurrence rate of the Death Valley-Furnace Creek fault zone	GP-01, RO	Geologic mapping	01 Mar 83
	GP-02, RO	Subsurface investigations	01 Mar 83
	GP-03, RO	Stratigraphic studies	01 Mar 83
Analysis of rotation (drag) of bedrock alongside or over suspected wrench faults based on rotation of paleomagnetic poles	GPP-06, RO	Rock and paleomagnetic investigations	01 Nov 84
	TBD	Hand-held drilling and oriented-core sampling for paleomagnetic evaluation	

^aTBD = to be determined.

8.3.1.17.4.3.3 Activity: Evaluate the Cedar Mountain earthquake of 1932 and its bearing on wrench tectonics of the Walker Lane within 100 km of the site

Objectives

The objective of this activity is to evaluate the relevance of the Cedar Mountain earthquake of 1932 to potential sources of ground shaking and rupture in that part of the Walker Lane within 100 km of Yucca Mountain.

Parameters

The parameters for this activity are

1. Geologic structure and stratigraphy of Stewart and Monte Cristo valleys.
2. Stewart and Monte Cristo Valley faults and their relation to the Walker Lane.
3. Surface ruptures formed during 1932 Cedar Mountain earthquake.

CONSULTATION DRAFT

4. Focal mechanism of the 1932 Cedar Mountain earthquake.

Description

This activity will entail a review of the published geologic literature concerning the Cedar Mountain earthquake, photogeologic interpretation, limited fieldwork, and evaluation of concurrent research by investigators not affiliated with the Project. Emphasis will be on the tectonic setting (is it part of Walker Lane, Churchill Arc, or both?), continuity with Quaternary faults of Stewart Valley and with through-going shears mapped by Ekren and Byers (1985), distribution and character of surface breaks, and recurrence history.

Ruptures will be classified according to style and length measured by scaling from maps by Molinari (1984), and Gianella and Callaghan (1934a,b). Selected ruptures will be examined in the field. The width of the rupture zone, the width of individual ruptures, and other attributes (length, offset, aperture, fissure-fillings, brecciation) will be noted. The rupture zone has been trenched by investigators not affiliated with the NNWSI Project. Additional trenching is not anticipated. This activity is estimated to be 50 percent complete.

Published and unpublished data will be searched for an analysis of the focal mechanism of the 1932 earthquake. Unless a reliable mechanism is available, archived seismograms of the earthquake will be examined, and if feasible, an analysis of the focal mechanism prepared. The estimated duration of future work is 6 to 12 months.

Methods and technical procedures

The methods and technical procedures for Activity 8.3.1.17.4.4.3 are given in the following table:

Method	Technical procedure		
	Number	Title	Date
	(NWM-USGS-)		
Analysis of tectonic setting and ruptures (1932 Cedar Mountain earthquake)	GP-01, RO	Geologic mapping	01 Mar 83
	GP-07, RO	Geologic trenching studies	14 Aug 84
	TBD ^a	Photogeologic evaluation of faults using vertical aerial photographs	TBD

CONSULTATION DRAFT

Method	Technical procedure		Date
	Number	Title	
	(NWM-USGS-)		
Determination of focal mechanism, Cedar Mountain earthquake	SP-06, RO	Procedure for the determination of earthquake focal mechanism	14 Sep 81

^aTBD = to be determined.

8.3.1.17.4.3.4 Activity: Evaluate the Bare Mountain fault zone

Objectives

The objectives of this activity are to

1. Evaluate the potential for ground shaking associated with future movement along the Bare Mountain fault zone.
2. Estimate the age of the most recent faulting on the Bare Mountain frontal fault.
3. Estimate the recurrence intervals of faulting.
4. Determine the nature and age of faulting within the fault complex east of the frontal zone, and to determine nature of tectonic control of the location and orientation of the main wash in Crater Flat.
5. Determine the subsurface configuration of fault zones.

Parameters

The parameters for this activity are

1. Age of datums.
2. Amount and direction of offset of datums.
3. Geologic structure and stratigraphy, seismic reflections.

Description

Bare Mountain has a steep, curvilinear eastern range front, the configuration of which is controlled by a complex of steeply eastward and moderately southeastward-dipping faults having Quaternary displacement. This complex is referred to as the Bare Mountain fault zone.

CONSULTATION DRAFT

This activity consists of (1) geologic mapping of the fault zone, and (2) trenching and dating of deposits cut by the fault zone.

Alluvial fans and stream deposits within Crater Flat along the eastern flank of Bare Mountain (Bare Mountain 15-min quadrangle (USGS, 1954)) will be mapped and deposits dated through soil development, uranium-series, and uranium-trend analysis, thermoluminescence, and cation ratios (desert varnish). Trenches intersecting the trace of the frontal fault will be excavated and mapped. Deposits offset by and overlapping the rupture zones exposed in the trenches will be dated.

Two new trenches are planned, and two existing prospect pits are to be enlarged, as follows:

1. Bulldozer trench, south side Tarantula Canyon, existing road. SW/4, NE/4, sec. 29, T.12S., R.48E. Estimated depth 3 to 4 m, width 5 m, length 15 to 20 m.
2. Backhoe trench, no existing road. SE/4, NW/4, sec. 24, T.13S., R47-1/2E. Estimated depth 2 to 3 m, width 2 to 3 m, length 5 m.
3. Enlargement of two existing adjacent prospect pits using backhoe, existing road. SW/4, SW/4, sec. 25, T.13S., R.47-1/2E. Estimate increase depth from 3 to 5 m, enlarge slightly.

This activity is 75 percent complete, and one report has been published (Reheis, 1986). The duration of the future work is 6 to 12 months.

Methods and technical procedures

The methods and technical procedures for Activity 8.3.1.17.4.3.4 are given in the following table.

Method	Technical procedure		Date
	Number	Title	
	(NWM-USGS-)		
Evaluation of age of Bare Mountain frontal zone faulting based on offset of Quaternary datums	GP-01, RO	Geologic mapping	01 Mar 83
	GP-02, RO	Subsurface investigations	01 Mar 83
	GP-07, RO	Geologic trenching studies	14 Aug 84
	GP-17, RO	Describing and sampling soils in the field	19 Feb 86
	GCP-01, RO	Radiometric-age data bank	15 Jun 81

CONSULTATION DRAFT

Method	Technical procedure		Date
	Number	Title	
	GCP-02, RO	Labeling, identification, and control of samples for geochemistry and isotope geology	20 Jan 87
	GCP-03, RO	Uranium-series dating	15 Jun 81
	GCP-04, RO	Uranium-trend dating	15 Jun 81
	TBD ^a	Thermoluminescence	TBD
	TBD	Cation ratio (desert varnish) dating	TBD

^aTBD = to be determined.

8.3.1.17.4.3.5 Activity: Evaluate structural domains and characterize the Yucca Mountain region with respect to regional patterns of faults and fractures

Objectives

The objectives of this activity are to

1. Map faults and lineaments within a 100 km radius of the site and to identify those with geomorphic expression indicative of Quaternary faulting.
2. Classify the area into subareas (domains) containing relatively homogeneous fault and lineament populations (prominent geomorphic expression, density, and orientation) suggestive of Quaternary faulting. This information will be used in Activity 8.3.1.17.2.1.2 to help assess the faulting potential in areas of emplaced waste.
3. Map the areal extent of desert varnish coatings. This information will be used in Activity 8.3.1.17.4.9.1 to help establish the areal extent of tectonically stable areas near Yucca Mountain.
4. Identify areas of suspected hydrothermal alteration. This information will be used in Study 8.3.1.9.2.1 (natural resource assessment) to evaluate the relationship of the suspected hydrothermal alteration to potential mineralization in Activity 8.3.1.5.2.1.5 (calcite- and opaline-vein deposits) to aid in evaluating the possible origin of calcite-silica deposits and in Study 8.3.1.8.5.2 to aid in evaluating local heat flow anomalies.

CONSULTATION DRAFT

Parameters

The parameters for this activity are

1. Fracture orientation, length, distribution.
2. Optical reflectance and absorption for selected wavelengths.
3. Age and distribution of desert varnish.
4. Distribution of hydrothermal alteration.

Description

High-quality Landsat V Thematic Mapper (TM) data provide a uniform set of data for the region and can be applied to numerous geologic problems. In this activity, a variety of remote sensing techniques will be applied to geologic problems being investigated in the region, including (1) analysis of linear features detectable with the high-resolution TM data, and characterization of regional fracture patterns, (2) mapping of the distribution of hydrothermal alteration related to near-surface igneous processes based on the spectral reflectance characteristics of alteration-associated minerals by using computer-enhanced TM data supplemented by field evaluations, and (3) mapping of surfaces with a substantial coating of desert varnish to aid in defining areas of tectonic stability.

The area under study comprises most of four 1:100,000-scale quadrangles --Beatty, Indian Springs, Pahute Mesa, and Pahranaagat Range. Tapes of the four Thematic Mapper V scenes encompassing this area will be purchased, and spectral and spectral ratio maps will be prepared including bands sensitive to hydroxyl-containing minerals in the ultraviolet part of the spectrum. Computer-enhanced images will be interpreted, linear features identified, and their length and orientation measured. Domains containing distinctive patterns of fractures and lineaments will be delineated.

Color-ratio composite TM images will be used to identify areas of alteration. These areas will be reconnoitered in the field to determine the type of alteration and the nature of the causal volcanic or igneous processes. The estimated duration of the future work is two years.

Methods and technical procedures

The methods and technical procedures for Activity 8.3.1.17.4.3.5 are given in the following table.

Method	Technical procedure		
	Number	Title	Date
Analysis of Landsat V thematic mapper imagery of the Nevada Test Site region	TBD ^a	Analysis of linear features	TBD
	TBD	Analysis of hydrothermal alteration	TBD

Method	Technical procedure		Date
	Number	Title	
	TBD	Analysis of desert varnish coating	TBD

^aTBD = to be determined.

8.3.1.17.4.4 Study: Quaternary faulting proximal to the site within northeast-trending fault zones

Objectives

The primary objective of this study is to evaluate the potential for ground motion resulting from future movement on Quaternary left-lateral(?) strike-slip faults east and south of the site-area.

The left-lateral(?) strike-slip faults in that area strike to the northeast or east-northeast, and form an en echelon pattern within the Mine Mountain-Spotted Range structural zone (Carr, 1974), cutting across the northwestern extension of the Las Vegas Valley shear zone. The belt is aligned with the Pahranaagat shear zone to the east-northeast, and the Garlock fault to the west-southwest (Figure 8.3.1.17-9). Four of the left-lateral(?) faults show evidence of significant Quaternary displacement. From northwest to southeast, they are the Stagecoach Road fault, the Mine Mountain fault, the Cane Spring fault zone, and the Rock Valley fault zone (Figure 8.3.1.17-13).

The Stagecoach Road fault cuts across the southern end of Yucca Mountain. It could connect to the northeast with the Paintbrush Canyon fault (to be studied as part of Activity 8.3.1.17.4.6.2 (evaluate age and recurrence of movement on suspected and known Quaternary faults) or alternatively, continue northeastward across western Jackass Flats into the Calico Hills, as shown by Maldonado (1985a). The Mine Mountain fault zone (not to be confused with the Mine Mountain thrust fault) trends northeast, with mapped extent of approximately 27 km (scaled from Figure 7 of Carr, 1984), and extends from Jackass Flat through Mid Valley to Yucca Flat. The Rock Valley fault zone trends east-northeast, with mapped extent of approximately 68 km (scaled from Figure 7 of Carr, 1984), if discontinuous segments are included, and extends from Amargosa Desert through Rock Valley to Frenchman Flat. The Cane Spring fault zone trends northeast, with mapped extent of 23 km (scaled from Figure 7 of Carr, 1984).

The part of the Mine Mountain-Spotted Range structural zone in the area between and adjacent to the Mine Mountain and Rock Valley fault zones is marked by above average seismic activity. However, focal mechanism solutions generally indicate right-lateral movement on north-trending faults, rather

CONSULTATION DRAFT

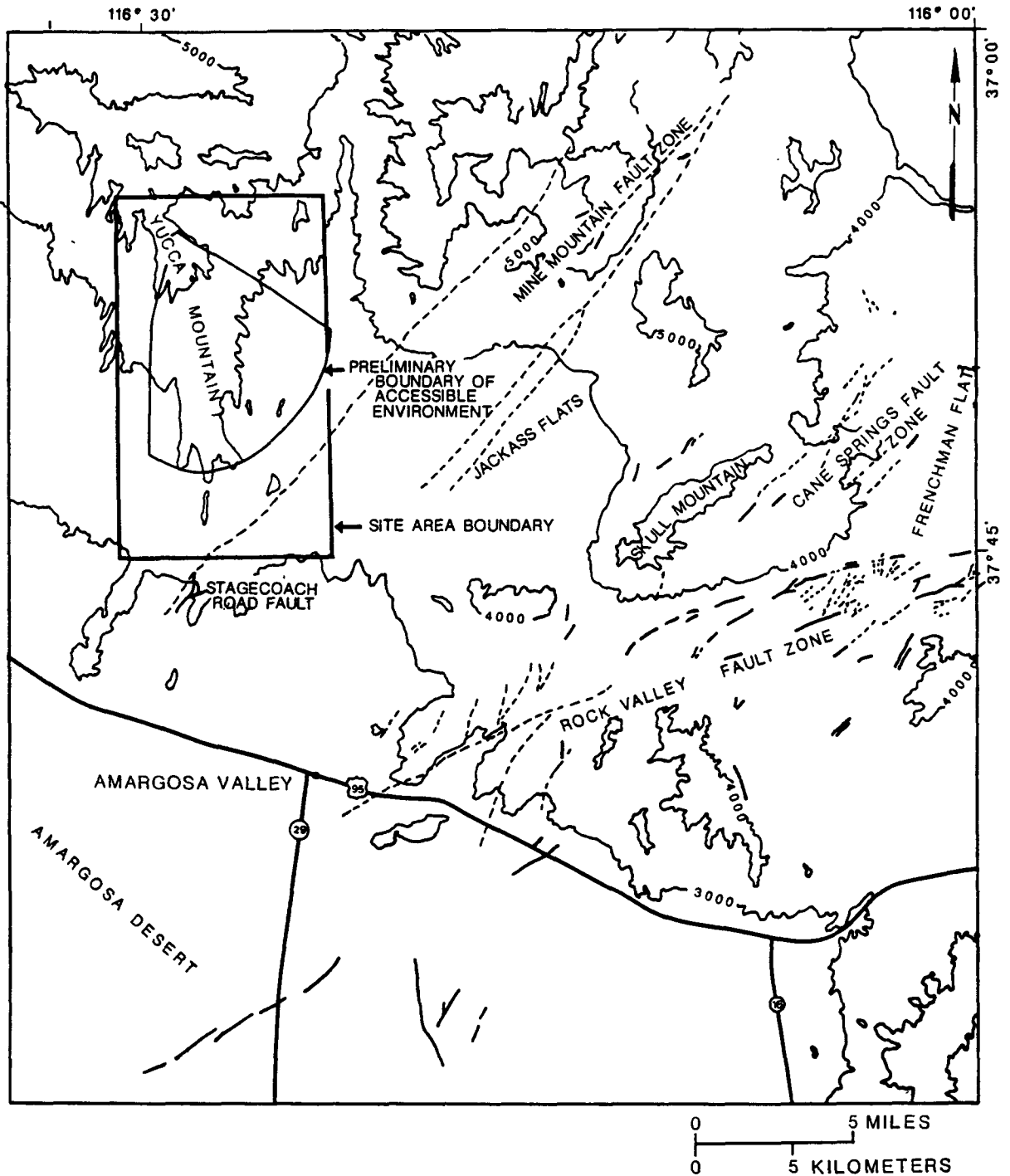

Figure 8.3.1.17-13. Map showing relation of proposed repository area to Mine Mountain, Cane Spring, Rock Valley, and Stagecoach Road fault zones.

than left-lateral movement parallel to the northeast to east-northeast-trending faults.

Activities planned for this study are (1) an evaluation of the Rock Valley fault system, (2) an evaluation of the Mine Mountain fault system, (3) an evaluation of the Stagecoach Road fault zone, and (4) an evaluation of the Cane Spring fault zone.

8.3.1.17.4.4.1 Activity: Evaluate the Rock Valley fault system

Objectives

The objective of this activity is to determine the location, spatial orientation, length, width, Quaternary recurrence rate, and the location, amount, and nature of Quaternary movement of the Rock Valley fault system.

Parameters

The parameters for the activity are

1. Length, location, and spatial orientation of the fault system.
2. Segmentation within the fault system.
3. Width of the fault system.
4. Age and nature of Quaternary deposits and Quaternary surfaces displaced by or covering Quaternary strands within the fault system.
5. Location, amount, and direction of displacement of Quaternary deposits and Quaternary surfaces.
6. Age, lateral extent, and height of fault scarps.

Description

This activity focuses on estimating the Quaternary rate of activity on the Rock Valley fault through trenching and mapping and dating of strata cut by the fault. Traces of the main strands of the fault will be examined and mapped, and the subsurface expression of the fault zone will be investigated through shallow seismic refraction and reflection surveys.

Evaluation of Quaternary displacement along main trace of the Rock Valley fault system as established by trenching and very shallow seismic refraction (Bison-type) and seismic reflection (mini-sosie). Two to four trenches will be excavated across fault scarps and fault lines, and the Quaternary stratigraphy exposed in trench walls and floor mapped. Areas of lateral disruption and discontinuity of Quaternary datums will be identified, and the age of disrupted Quaternary datums and overlying undisrupted Quaternary datums established, if present. The age of datums will be established through stratigraphic correlation, chemical fingerprinting, soil development analysis, radiocarbon dating, uranium-trend and uranium-series

CONSULTATION DRAFT

analysis, cation ratio dating, and other methods, as appropriate. The orientation of clast fabric in zones of rupture will be measured. Fracture-filling minerals will be identified and dated. The orientation of all fractures cutting the Quaternary deposits will be measured. By using portable seismic refraction apparatus (Bison-type), velocity profiles within very shallow (to depth of 100 m) deposits along selected traverses crossing known and suspected fault traces will be established. The subsurface configuration of the fault zone will be examined using shallow seismic reflection (mini-sosie) along a 1.5-km long (0.9 mi) traverse orthogonal to the fault. This subactivity is 95 percent complete.

Evaluation of Quaternary displacement along the southern extension of the Rock Valley fault system, south of Amargosa Valley. Faults cutting fine-grained sands and muds approximately 12 km (7 mi) south of Amargosa Valley appear to represent an extension of the Rock Valley fault system. Mapping, trenching, and shallow (Bison) seismic refraction will be undertaken to determine fault width, the horizontal and vertical components of slip along these faults, and the age of the deposits cut by the faults. Where applicable, all techniques described in the evaluation of the main trace of the Rock Valley fault will be used. One or two trenches at locations to be determined are planned. The estimated duration of this work is one year.

Methods and technical procedures

The methods and procedures for Activity 8.3.1.17.4.4.1 are given in the following table.

Method	Technical procedure		Date
	Number	Title	
	(NWM-USGS-)		
Evaluation of Quaternary displacement along main trace of the Rock Valley fault system as established by trenching and very shallow seismic refraction (Bison-type) and seismic reflection (mini-sosie)	GP-01, RO	Geologic mapping	01 Mar 83
	GP-03, RO	Stratigraphic studies	01 Mar 83
	GP-07, RO	Geologic trenching studies	14 Aug 84
	GCP-01, RO	Radiometric-age data bank	15 Jun 81
	GCP-02, RO	Labeling, identification and control of samples for geochemistry and isotope geology	20 Jan 87
	GCP-03, RO	Uranium-series dating	15 Jun 81
	GCP-04, RO	Uranium-trend dating	15 Jun 81
	TBD ^a	Chemical fingerprinting	TBD
	TBD	Dating by soil development analysis	TBD
	TBD	Radiocarbon dating	TBD

CONSULTATION DRAFT

Method	Technical procedure		Date
	Number	Title	
TBD		Cation ratio (desert varnish) dating	TBD
TBD		Shallow seismic refraction and reflection surveys	
Evaluation of Quaternary displacement along the southern extension of the Rock Valley fault system, south of Amargosa Valley	GP-01, RO	Geologic mapping	01 Mar 83
	GP-03, RO	Stratigraphic studies	01 Mar 83
	GP-07, RO	Geologic trenching studies	14 Aug 84
	GCP-01, RO	Radiometric age data bank	15 Jun 81
	GCP-02, RO	Labeling, identification and control of samples for geochemistry and isotope geology	20 Jan 87
GCP-03, RO	Uranium-series dating	15 Jun 81	
GCP-04, RO	Uranium-trend dating	15 Jun 81	
GP-08, RO	Correlation of tephra by means of chemical analysis		
TBD		Dating by soil development analysis	TBD
TBD		Radiocarbon dating	TBD
TBD		Cation ratio (desert varnish) dating	TBD
TBD		Shallow seismic refraction and reflection surveys	TBD

^aTBD = to be determined.

8.3.1.17.4.4.2 Activity: Evaluate the Mine Mountain fault system

Objectives

The objective of this activity is to determine the location, spatial orientation, length, width, Quaternary recurrence rate, and the location, amount and nature of Quaternary movement of the Mine Mountain fault system.

CONSULTATION DRAFT

Parameters

The parameters for this activity are

1. Length, location, and spatial orientation of the fault system.
2. Segmentation within the fault system.
3. Width of the fault system.
4. Age and nature of Quaternary deposits and Quaternary surfaces displaced by or covering Quaternary strands within the fault system.
5. Location, amount and direction of displacement of Quaternary deposits and Quaternary surfaces.
6. Age, lateral extent, and height of fault scarps.

Description

A substantial body of data on the Mine Mountain fault system has been collected, including geologic maps of the surface expression of the fault, and reflection seismologic studies of the subsurface expression. In this activity, that data will be compiled and interpreted. Additional field investigations will include evaluation of Quaternary scarps and lineaments along the trace of the fault toward and beneath Jackass Flat.

This activity will synthesize and evaluate results of geologic mapping, paleostress investigations, magnetotelluric soundings, and seismic reflection surveys conducted as an adjunct to the NTS weapons program.

Methods and technical procedures

The method and technical procedure for this activity are given in the following table.

Method	Technical procedure		Date
	Number	Title	
Mine Mountain fault system synthesis	TBD ^a	Geologic synthesis	TBD

^aTBD = to be determined.

8.3.1.17.4.4.3 Activity: Evaluate the Stagecoach Road fault zone

Objectives

The objectives of this activity are to

1. Determine the location, spatial orientation, length, width, Quaternary recurrence rate, and the location, amount, and nature of Quaternary movement of the Stagecoach Road fault system.
2. Evaluate the possibility that the Stagecoach Road fault zone is a continuation of the Paintbrush Canyon fault.
3. Evaluate the geometry of the intersection in the subsurface of the Paintbrush Canyon fault and hypothesized shallow detachment faults.

Parameters

The parameters for this activity are

1. Length, location, and spatial orientation of the fault system.
2. Segmentation within the fault system.
3. Width of the fault system.
4. Age and nature of Quaternary deposits and Quaternary surfaces displaced by or covering Quaternary strands within the fault system.
5. Location, amount and direction of displacement of Quaternary deposits and Quaternary surfaces.
6. Age, lateral extent, and height of fault scarps.
7. Subsurface geometry of the fault zone.
8. Geometry of intersection with Paintbrush Canyon fault.
9. Continuity in subsurface between southern Yucca Mountain and Calico Hills.

Description

This activity focuses on (1) estimating the Quaternary rate of activity on the Stagecoach fault through trenching, mapping, and dating of strata and geomorphic features cut by the fault, and (2) determining the chronologic and tectonic relationship between the Stagecoach fault and the Paintbrush Canyon-Busted Butte fault system. In addition, the subsurface expression of the fault zone will be investigated through shallow seismic refraction surveys and possibly reflection surveys.

Surficial deposits and geomorphic features will be mapped in detail to determine the apparent strike-slip component of fault movement. Two to four trenches will be excavated across fault scarps and fault lines at locations

CONSULTATION DRAFT

to be determined, and the Quaternary stratigraphy exposed in trench walls and floor mapped. Areas of lateral disruption and discontinuity of Quaternary datums will be identified, and the age of disrupted datums and overlying undisrupted Quaternary datums established, if present. The age of the datums will be established through stratigraphic correlation, chemical fingerprinting, soil development analysis, radiocarbon dating, uranium-trend and uranium-series analysis, cation-ratio dating, and other methods, as appropriate. The orientation of clast fabric in zones of rupture will be measured. Fracture-filling minerals will be identified and dated. The orientation of all fractures cutting the Quaternary deposits will be measured. Scarps and lineaments will be mapped, and the subsurface geometry investigated using shallow seismic refraction methods. A shallow seismic reflection profile (mini-sosie) will be surveyed as part of Activity 8.3.1.17.4.7.8 (evaluate shallow seismic reflection (mini-sosie) methods) provided that method proves to be effective. Information on the subsurface geometry will also be provided through application of other geophysical methods, as described in Activity 8.3.1.17.3.1 (evaluate crustal structure and subsurface expression of Quaternary faults in an east-west transect crossing the Furnace Creek fault zone, Yucca Mountain, and the Walker Lane). Expected duration of this activity is two years.

Methods and technical procedures

The methods and technical procedures for Activity 8.3.1.17.4.4.3 are given in the following table.

Method	Technical procedure		
	Number	Title	Date
(NWM-USGS-)			
Evaluation of Quaternary displacement along main trace of the Stagecoach Road fault zone as established by trenching and mapping	GP-01, RO	Geologic mapping	1 Mar 83
	GP-03, RO	Stratigraphic studies	1 Mar 83
	GP-07, RO	Geologic trenching studies	14 Aug 84
	GP-17, RO	Describing and sampling soils in the field	19 Feb 86
	GCP-01, RO	Radiometric-age data bank	15 Jun 81
	GCP-02, RO	Labeling, identification and control of samples for geochemistry and isotope geology	20 Jan 87
	GCP-03, RO	Uranium-series dating	15 Jun 81
	GCP-04, RO	Uranium-trend dating	15 Jun 81
	TBD ^a	Chemical fingerprinting	TBD
	TBD	Dating by soil development analysis	TBD
	TBD	Radiocarbon dating	TBD

Method	Technical procedure		Date
	Number	Title	
	TBD	Cation ratio (desert varnish) dating	TBD
	TBD	Shallow seismic refraction and reflection surveys	TBD

^aTBD = to be determined.

8.3.1.17.4.4.4 Activity: Evaluate the Cane Spring fault system

Objectives

The objective of this activity is to determine the location, spatial orientation, length, width, Quaternary recurrence rate, and the location, amount, and nature of Quaternary movement of the Cane Spring fault system.

Parameters

The parameters for this activity are

1. Length, location, and spatial orientation of the fault system.
2. Segmentation within the fault system.
3. Width of the fault system.
4. Age and nature of Quaternary deposits and Quaternary surfaces displaced by or covering Quaternary strands within the fault system.
5. Location, amount, and direction of displacement of Quaternary deposits and Quaternary surfaces.
6. Age, lateral extent, and height of fault scarps.

Description

This activity focuses on evaluation of the potential of the Cane Springs fault system to produce moderate to large earthquakes. The Cane Spring fault system trends northeast between Skull Mountain and Frenchman Flat, bisecting the region lying between the Rock Valley fault zone and the Mine Mountain fault zone. Offset of bedrock by the fault indicates significant left-lateral movement in later Tertiary. Distinct alignments of brush and physiographic features in Quaternary material along the fault trace suggests that movement has continued into the Quaternary, particularly at the northeast end of the fault system. Detailed mapping of surficial deposits along the fault

CONSULTATION DRAFT

trace, including soil description and shallow seismic (Bison) refraction is planned to evaluate the possibility that the lineaments are caused by faulting of Quaternary deposits. If strong indications of faulting are found, then selected fault traces will be trenched, and the age of faulted and unfaulted units intersected by the fault will be determined. The expected duration of this activity is six months.

Methods and technical procedures

The methods and technical procedures for Activity 8.3.1.17.4.4.4 are given in the following table.

Method	Number	Technical procedure	
		Title	Date
Evaluation of the Cane Spring fault system	GP-01, RO	Geologic mapping	1 Mar 83
	GP-03, RO	Stratigraphic studies	1 Mar 83
	GP-07, RO	Geologic trenching studies	14 Aug 84
	GCP-01, RO	Radiometric-age data bank	15 Jun 81
	GCP-02, RO	Labeling, identification, and control of samples for geo-chemistry and isotope geology	20 Jan 87
	GCP-03, RO	Uranium-series dating	15 Jun 81
	GCP-04, RO	Uranium-trend dating	15 Jun 81
	TBD ^a	Chemical fingerprinting	TBD
	TBD	Dating by soil development analysis	TBD
	TBD	Radiocarbon dating	TBD
	TBD	Cation ratio (desert varnish) dating	TBD
	TBD	Shallow seismic refraction and reflection	TBD

^aTBD = to be determined.

8.3.1.17.4.5 Study: Detachment faults at or proximal to Yucca Mountain

Objectives

The objective of this study is to supply information pertaining to the distribution, displacement rate, and age of detachment faults proximal to Yucca Mountain. The key questions regarding detachment faults are (1) whether they represent a significant earthquake source, and (2) whether they conceal a significant earthquake source at depth. To resolve both questions,

CONSULTATION DRAFT

activities are focused on resolving the Quaternary behavior of postulated detachment faults.

Review of detailed (1:24,000 to 1:62,500 scale) maps of the NTS and adjacent areas to the west (Bare Mountain and Beatty areas), using current concepts of structural geology, suggests that some features mapped as depositional contacts or thrust faults are in fact detachment faults. In particular, the basal contact of Oligocene-Miocene sedimentary rocks or Miocene volcanic rocks on Paleozoic rocks in the Mercury, Calico Hills, and Bare Mountain areas appears at several localities to be a detachment fault of moderate (perhaps one to several kilometers) displacement. Recent mapping south and west of Beatty shows that the basal contact of the Miocene volcanic rocks is a detachment fault with substantial displacement (Maldonado, 1985b).

Structural analysis of deformed and faulted Miocene ash-flows suggests that the entire area of Yucca Mountain, including the area of the proposed repository, is underlain at unknown depth by one or more detachment faults (Scott, 1986; Scott and Whitney, 1987). This possibility has not been confirmed, nor has the depth, attitude, and total extent of the postulated detachment(s) been determined. Conjecturing that the uppermost detachment fault corresponds to the contact between Miocene volcanic rocks and subjacent Paleozoic rocks, preliminary reinterpretation of published gravity data (Synder and Carr, 1984), suggests that this detachment(?) surface slopes moderately in a N.60W. direction, which is the direction of least horizontal stress (Stock et al., 1985). That surface, or a high-angle fault offsetting it (M. D. Carr et al., 1986) was intersected in drill hole UE-25p#1 at a depth of about 1200 m.

If detachment faults exist at depth below the site, their relevance to repository design and performance as potential sources of ground motion, rupture, or hydrologic conduits or barriers hinges on their age, depth, and nature of the intersection of the detachment faults with the steeply dipping Quaternary normal faults within the site area. This study focuses on examination of suspected detachment faults where they are exposed in areas adjacent to Yucca Mountain. Information on the potential subsurface extent and geometry of detachment faults and their possible connection to listric Quaternary faults at Yucca Mountain is derived through geophysical studies described in Activity 8.3.1.17.4.3.1 (evaluate crustal structure and subsurface expression of Quaternary faults in an East-West transect crossing the Furnace Creek fault zone, Yucca Mountain, and the Walker Lane) and Study 8.3.1.17.4.7 (subsurface geometry and concealed extensions of Quaternary faults at Yucca Mountain).

NNWSI Project strategy for investigating the age and displacement rate of detachment faults includes five elements:

1. Observation of contact relations of detachment faults and Quaternary deposits at the outcrop and measurements of the radiometric age of detachment surfaces, to be undertaken as part of this study.
2. Evaluation of the subsurface geometric relationship of detachment faults (as deduced from geophysical studies described above and hydrologic and site-geology drillhole data) to Quaternary high-angle

CONSULTATION DRAFT

faults, such as the Bare Mountain fault, the Windy Wash fault, and the Paintbrush Canyon fault.

3. Evaluation of the recurrence rate and displacement history of Quaternary high-angle faults that could merge with detachment faults in the subsurface, to be undertaken as part of Study 8.3.1.17.4.6 (Quaternary faulting within the site area) and other studies of faulting.
4. Evaluation of in situ stress data developed within Study 8.3.1.17.4.8 (stress field within and proximal to the site area).
5. Evaluation of focal mechanism solutions developed in Study 8.3.1.17.4.1 (historical and current seismicity).

This information is to be synthesized in Study 8.3.1.17.4.12 (tectonic models and synthesis), which will (1) evaluate the possibility that one or more detachment faults are present in the subsurface below or in the vicinity of the proposed repository site, and (2) if considered to be present, evaluate the direction and rate of movement of the upper plate, the depth and configuration of the fault surfaces, and the nature of the association, if any, between the detachment fault(s) and the normal faults in the upper plate.

Activities planned for this study are to evaluate (1) the significance of the Miocene-Paleozoic contact in the Calico Hills area to detachment faulting within the site area, (2) postulated detachment faults in the Beatty-Bare Mountain area, (3) the potential relationship of megabreccia within and south of Crater Flat to detachment faulting, (4) postulated detachment faults in the Specter Range and Camp Desert Rock areas, and (5) the age of detachment faults by using radiometric ages.

- 8.3.1.17.4.5.1 Activity: Evaluate the significance of the Miocene-Paleozoic contact in the Calico Hills area to detachment faulting within the site area

Objectives

The objectives of this activity are (1) to determine whether the contact of Miocene volcanic rocks on Paleozoic strata is tectonic or depositional, (2) if tectonic, to determine the Quaternary activity, if any, of the possible detachment fault, and (3) if Quaternary, the direction and age of movement, attitude of fault plane, and nature of deformation of the Miocene (upper plate?) sequence.

Parameters

The parameters for this activity are geologic structure and stratigraphy.

CONSULTATION DRAFT

Description

The contact between Miocene volcanic (and volcanoclastic) rocks and adjacent Paleozoic strata, which lies a kilometer or more below the surface at the site of the proposed repository at Yucca Mountain, surfaces a few kilometers to the northeast in the Calico Hills. The volcanic rocks are broken by faults, some with displacement in excess of 200 m, and locally are moderately to steeply tilted. This activity is designed to establish whether the contact with Paleozoic strata is tectonic or depositional, and if tectonic, whether the Miocene volcanic rocks are part of a detachment-bounded upper plate or not. The activity calls for conventional geologic mapping.

The suspected tectonic contact between Miocene rocks and Paleozoic rocks in the Calico Hills area will be mapped in detail with particular attention to evidence bearing on age of movement and displacement rate, including apparent offset of the Miocene-Paleozoic contact by pre-Quaternary faults. The Calico Hills area and vicinity will be mapped using conventional field methods, including annotation of field observations on large-scale (1:12,000) aerial photographs (color or false color, where available), and compiled at 1:24,000 scale. This activity is estimated to be 75 percent complete. The expected duration of the future work is six months.

Methods and technical procedures

The method and technical procedure for Activity 8.3.1.17.4.5.1 are given in the following table.

Method	Technical procedure		
	Number	Title	Date
	(NWM-USGS)		
Detailed mapping and analysis of suspected tectonic contact between Miocene rocks and Paleozoic rocks in Calico Hills area	GP-01, RO	Geologic mapping	01 Mar 83

CONSULTATION DRAFT

8.3.1.17.4.5.2 Activity: Evaluate postulated detachment faults in the Beatty-Bare Mountain area

Objectives

The objectives of this activity are

1. To determine if postulated detachment faults in the Beatty-Bare Mountain have been active in the Quaternary.
2. If Quaternary, to
 - a. Establish the displacement rate, location, and nature of the low-angle imbricate fault zones between lineated and mylonitized and variably recrystallized gneiss of the northern Amargosa Desert and the Paleozoic and Miocene rocks of the Beatty area, and to ascertain the nature of deformation of the Miocene (upper plate?) rocks.
 - b. Establish the displacement rate, location, and nature of the low-angle fault zone between Paleozoic rocks of Bare Mountain and the Miocene volcanic rocks north of Bare Mountain, and to ascertain the nature of deformation of the Miocene (upper plate?) rocks.
 - c. Ascertain the nature of internal deformation of Paleozoic rocks, their degree of metamorphism, the nature of suspected low-angle tectonic contact with the lineated and mylonitized gneiss of the northern Amargosa Desert, and the nature of the suspected low-angle tectonic contact with Miocene rocks at the northern end of Bare Mountain.

Parameters

The parameters for this activity are geologic structure and stratigraphy, age of datums, and amount and direction of offset of datums.

Description

The Beatty-Bare Mountain area, centered about 27-km west of the proposed repository at Yucca Mountain, is interpreted as an eroded and beveled stack of imbricated detachment-fault-bounded plates. The lowest exposed plate, cropping out in the northern Amargosa Desert southwest of Beatty, consists of lineated and mylonitized crystalline rocks, schist, and semischist. It is structurally overlain by one or more intermediate plates, consisting of moderately to weakly metamorphosed Precambrian and Paleozoic strata that form the Bare Mountain massif. The Bare Mountain massif is in turn structurally overlain by an upper plate, which west of Beatty, consists of Miocene volcanic and volcanoclastic strata. Older geologic maps have been reinterpreted and this reinterpretation suggests that the detachment between the intermediate (Bare Mountain) plates and the upper plate extends east of Beatty, curving around the north side of Bare Mountain, and is cut off by the Bare Mountain frontal fault.

CONSULTATION DRAFT

This activity is designed to work out the structural geology of this detachment complex through conventional geologic mapping.

Detailed mapping and analysis of Beatty-Bare Mountain area--Bullfrog N.E. 7.5-min quadrangle. The Miocene rocks and their contact with subjacent units will be mapped using conventional field methods, including annotation of field observations on medium-scale (1:20,000) black-and-white and color-aerial photographs, and compilation at 1:24,000 scale. This subactivity is 95 percent complete. A map-report describing results of this mapping is in review.

Detailed mapping and analysis of Beatty-Bare Mountain area--Bare Mountain N.W. 7.5-min quadrangle. The Miocene rocks and their contact with subjacent units will be mapped using conventional field methods, including annotating field observations on medium-scale (1:20,000) black-and-white and color aerial photographs, and compiling at 1:24,000 scale. Estimated duration of work is one year.

Detailed mapping and analysis of Bare Mountain area--Bare Mountain S.W. 7.5-min quadrangle, plus parts of adjoining quadrangles. The Paleozoic rocks and their contact with overlying Miocene units and with subjacent units will be mapped using conventional field methods, including annotating field observations on medium-scale (1:20,000) black-and-white and color aerial photographs, and compiling at 1:24,000 scale. This subactivity is estimated to be 75 percent complete. The duration of the future work is six months.

Methods and technical procedures

The methods and technical procedures for Activity 8.3.1.17.4.5.2 are given in the following table.

Method	Technical procedure		
	Number	Title	Date
	(NWM-USGS-)		
Detailed mapping and analysis of Beatty-Bare Mountain area - Bullfrog N.E. 7.5-min quadrangle	GP-01, RO	Geologic mapping	1 Mar 83
Detailed mapping and analysis of Beatty-Bare Mountain area - Bare Mountain N.W. 7.5-min quadrangle	GP-01, RO	Geologic mapping	1 Mar 83

CONSULTATION DRAFT

Method	Technical procedure		Date
	Number	Title	
Detailed mapping and analysis of Bare Mountain area - Bare Mountain S.W. 7.5-min quadrangle, plus parts of adjoining quadrangles	GP-01, RO	Geologic mapping	1 Mar 83

8.3.1.17.4.5.3 Activity: Evaluate the potential relationship of megabreccia within and south of Crater Flat to detachment faulting

Objectives

The objective of this activity is to determine whether megabreccias tectonically emplaced on low-angle surfaces beveled across Paleozoic and younger strata are slide masses or distal near-surface parts of a detached upper plate; and if either, how they relate to postulated Quaternary detachment faulting.

Parameters

The parameters for this activity are

1. Distribution of megabreccia in the subsurface below Crater Flat.
2. Nature of fragmentation of the megabreccia.
3. Nature of basal contact of the megabreccia, including indicators of direction of relative movement.

Description

Megabreccias intersected in VH-2 (Carr and Parrish, 1982), located in the central part of Crater Flat between Red Cone and Black Cone, could be the lateral extension of similar material cropping out above Miocene volcanic rocks along the southern rim of Crater Flat. The megabreccias appear to be monolithologic, composed chiefly of Paleozoic carbonate whose nearest obvious source is Bare Mountain. In this activity, recently completed detailed maps of the area within which the megabreccia crops out will be reviewed, as will cores from USW VH-1 and USW VH-2. Field work, limited to examination of outcrops along the southern rim of Crater Flat, will focus on evaluation of the internal character and nature of the basal contact of the megabreccia. The expected duration of this work is six months.

CONSULTATION DRAFT

Methods and technical procedures

The methods and technical procedures for Activity 8.3.1.17.4.5.3 are given in the following table.

Method	Number	Technical procedure	
		Title	Date
Evaluation of megabreccia in and south of Crater Flat	GP-02, RO	Subsurface investigations	1 Mar 83
	GP-04, RO	Structural studies	1 Mar 83

8.3.1.17.4.5.4 Activity: Evaluate postulated detachment faults in the Specter Range and Camp Desert Rock areas

Objectives

The objective of this activity is to determine whether the basal contact of the Horse Spring Formation is depositional or tectonic; and if tectonic, to determine whether movement was Quaternary or older and, if Quaternary, to determine the direction and amount of offset, the amount of extension, and the style of internal deformation of the upper plate.

Parameters

The parameters of this activity are geologic structure and stratigraphy.

Description

The contact between Miocene strata and Paleozoic strata crops out in the Specter Range and Camp Desert Rock areas. Preliminary reconnaissance indicates that in places the contact is tectonic and that the Miocene rocks locally form a detachment-fault-bounded upper plate. In this area, the basal Miocene (possible partly Oligocene) strata are dominantly lacustrine and fluvial deposits that become progressively more volcanogenic up-section. This activity includes conventional geologic mapping, with emphasis on structure of the Paleozoic-Miocene contact and on stratigraphy and basin analysis of the Miocene sedimentary deposits. Ashes intercalated in the section will be dated using potassium-argon dating methods. Although the primary area of interest is the Specter Range and Camp Desert Rock area, Miocene (Oligocene?) stratigraphy in other areas, including the Funeral Mountains and the Sheep Mountains, will be studied for purposes of comparison.

The stratigraphy and structure of the Horse Springs-Pavits Spring sequence in the Specter Range and Camp Desert Rock areas will be evaluated. The basal contact of the Horse Springs will be mapped in detail using conventional field methods, with field mapping annotated on 1:20,000 scale

CONSULTATION DRAFT

vertical black-and-white or color aerial photographs, and then compiled at 1:24,000 scale. Internal structure, stratigraphy, provenance, and age of the Horse Springs-Pavits Spring sequence will be investigated using conventional procedures. This activity is approximately 50 percent complete. The estimated duration of the remaining work is two years.

Methods and technical procedures

The methods and technical procedures for Activity 8.3.1.17.4.5.4 are given in the following table.

Method	Technical procedure		Date
	Number	Title	
	(NWM-USGS-)		
Evaluation of the stratigraphy and structure of the Horse Springs-Pavits Spring sequence in the Specter Range and Camp Desert Rock areas	GP-01, RO	Geologic mapping	1 Mar 83
	GP-03, RO	Stratigraphic studies	1 Mar 83
	GP-04, RO	Structural studies	1 Mar 83
	GCP-06, RO	Potassium-argon dating	15 June 81

8.3.1.17.4.5.5 Activity: Evaluate the age of detachment faults using radiometric ages

Objectives

The objectives of this activity are to

1. Determine if the subdetachment basement and the Bare Mountain massif cooled through the blocking temperatures of zircon and apatite during the Quaternary period.
2. Determine if the Northern Amargosa core complex cooled through the blocking temperatures of muscovite and biotite during the Quaternary period.

Parameters

The parameters of this activity are

1. Fission-track ages of zircon and apatite.
2. Location of dated samples with respect to detachment surfaces.
3. Potassium-argon dating method ages of muscovite and biotite.

CONSULTATION DRAFT

Description

Rocks forming the Northern Amargosa core complex include lineated and mylonitized crystalline rocks, schist, and semi-schist. These rocks were probably deformed at or below the ductile-brittle transition zone (i.e., at crustal depths in excess of 5 km). Exposure of these rocks requires substantial tectonic denudation. The rate and timing of this denudation is not known. Structurally higher detachment faults cut volcanic rocks as young as 7.5 million years; possibly all the denudation took place since that time. The detachment faults are also possibly in part rejuvenated Mesozoic features; if so, much of the denudation is pre-Neogene. This activity is designed to determine if the mid-crustal rocks of the core complex cooled through the blocking temperatures of zircon or apatite during the Quaternary. The Precambrian and Paleozoic rocks of the Bare Mountain massif may form a detached plate structurally overlying the Northern Amargosa rocks. Fission-track dating of zircon and apatite from these rocks should constrain the age of denudation and cooling.

Fission-track dating of the northern Amargosa Desert core complex (area of high-grade lineated and mylonitized gneiss, schist, and semi-schist constituting the subdetachment basement) and the Bare Mountain massif (deformed Precambrian and Paleozoic strata). Samples will be collected from the central part of the northern Amargosa Desert core complex, from the shear zones marking the detachment surfaces between the core complex and the overlying plate of Paleozoic rocks, and from between that plate and the uppermost plate of Miocene volcanic rocks. At Bare Mountain, samples will be collected at low elevation from the deeply dissected central part of the massif, from the shear zone marking the detachment at the northern end of the massif, and from the shear zone exposed at low elevation along the eastern front of the range. Zircon and apatite separated from these samples will be dated using standard fission-track dating procedures. This subactivity is approximately 25 percent complete. The estimated duration of this work is two years.

Potassium-argon dating of the northern Amargosa core complex (area of high-grade lineated and mylonitized gneiss, schist, and semi-schist constituting the subdetachment basement). Samples will be collected from the central part of the core complex, from suitable targets nearest the shear zone marking the detachment surface separating the core complex from structurally overlying plate of Paleozoic rocks, and from dike rocks within the uppermost plate that are truncated by the basal detachment of that plate. Suitable minerals (muscovite and biotite) will be separated from these samples and their age determined using standard potassium-argon dating techniques. This subactivity is currently under way and approximately 25 percent complete. The estimated duration of this work is two years.

Methods and technical procedures

The methods and technical procedures for Activity 8.3.1.17.4.5.5 are given in the following table.

CONSULTATION DRAFT

Method	Technical procedure		Date
	Number	Title	
	(NWM-USGS-)		
Fission-track dating of the northern Amargosa Desert core complex (area of high-grade lineated and mylonitized gneiss, schist, and semi-schist constituting the subdetachment basement) and the Bare Mountain massif (deformed Paleozoic strata)	GCP-01, RO	Radiometric age data bank	15 Jun 81
	GCP-02, RO	Labeling, identification, and control of samples for geochemistry and isotope geology	20 Jan 87
	GCP-08, RO	Fission-track dating	15 Jun 81
Potassium-argon dating of the northern Amargosa core complex (area of high-grade lineated and mylonitized gneiss, schist, and semi-schist constituting the sub-detachment basement)	GCP-01, RO	Radiometric-age data bank	15 Jun 81
	GCP-02, RO	Labeling, identification, and control of samples for geochemistry and isotope geology	20 Jan 87
	GCP-06, RO	Potassium-argon dating	15 Jun 81

8.3.1.17.4.6 Study: Quaternary faulting within the site area

Objectives

The objectives of this study are (1) to identify and characterize Quaternary faults that intersect or project toward the surface facility, the repository, or the controlled area; and (2) to identify and characterize Quaternary faults at the site whose length or recurrence rate suggest a potential for future earthquakes with magnitude such that associated ground shaking could impact design or affect performance of the waste facility.

The site area is defined here as the rectangular 237 km² (91 mi²) area encompassing the central Yucca Mountain block and its structural and physiographic boundaries (Fortymile Wash, Yucca Wash, Solitario Canyon, and the Stagecoach Road fault) (Figure 8.3.1.17-11). Except for the southwest-striking, possibly left-lateral Stagecoach Road fault at the south boundary

CONSULTATION DRAFT

of the site, Quaternary faults within the site are predominantly north-trending, west-dipping normal- or oblique-slip faults. Potentially significant representatives of this group include the Paintbrush Canyon, the Bow Ridge, the Windy Wash, and the Solitario Canyon faults. Northwest-trending lineaments and faults are also present, but no Quaternary movement on them has been recognized.

Activities planned for this study are to (1) evaluate Quaternary geology and potential Quaternary faults at Yucca Mountain, and (2) evaluate age and recurrence of movement on suspected and known Quaternary faults.

Knowledge of the age, length, width, displacement rate, and recurrence interval of the Quaternary faults is required to establish the rate of faulting within the site area during the Quaternary, and the potential for ground shaking and rupture. Included in this study are investigations of known faults, relying primarily on mapping and trenching of Quaternary materials intersected by the faults to establish which datums are cut, and the direction and amount of offset. Also included are investigations of the precise age of Quaternary datums using direct dating methods and mapping to establish relative ages.

Information from this study will be useful in estimating the probability of future rupture or ground shaking. Knowledge of the age, recurrence interval, and length of faults are required for this estimate; this information will be provided through parallel investigations described previously, and other studies of faulting.

Faulting at the surface facility is the subject of a separate study (8.3.1.17.4.2, location and recency of faulting near prospective surface facilities). The Stagecoach Road fault, which intersects the southeastern boundary of the site area, is to be evaluated as part of Study 8.3.1.17.4.4 (Quaternary faulting proximal to the site within northeast-trending fault zones). Other geologic studies contributing to the evaluation of faults at the site include Study 8.3.1.17.4.3 (Quaternary faulting within 100 km of Yucca Mountain) and Study 8.3.1.17.4.5 (detachment faults at or proximal to Yucca Mountain).

Geophysical methods, including gravity surveys, magnetic surveys, and shallow reflection seismic surveys, will be used to establish continuity in the subsurface of fault segments observed at the surface at Yucca Mountain and vicinity and to evaluate the geometric relation of high-angle faults exposed at the surface to postulated detachment faults at depth. The geophysical work will be done as part of Study 8.3.1.17.4.7 (subsurface geometry and concealed extension of Quaternary faults at Yucca Mountain) and Activity 8.3.1.17.4.3.1 (evaluate crustal structure and subsurface expression of Quaternary faults in an east-west transect crossing the Furnace Creek fault zone, Yucca Mountain, and the Walker Lane).

The characteristics to be evaluated include the following: (1) fault length, (2) scarp height, (3) scarp morphology, (4) datums cut by fault and datums overlapping fault, (5) age of datums, (6) width of fault zone (including subsidiary fractures), (7) width and character of rupture zones, (8) fabric of sheared material within rupture zones, (9) age and character of mineral coatings and fracture fillings, (10) character of fracture surfaces,

CONSULTATION DRAFT

(11) gravity and magnetic expression of fault zones, (12) fault orientation at surface and at depth, (13) areal fault pattern, and (14) seismic expression of faults.

8.3.1.17.4.6.1 Activity: Evaluate Quaternary geology and potential Quaternary faults at Yucca Mountain

Objectives

The objectives of this activity are to

1. Synthesize and evaluate data pertaining to the location, spatial orientation, length, width, Quaternary recurrence rate, and the location, amount, and nature of Quaternary movement of faults within the site area.
2. Identify hitherto unrecognized Quaternary faults within the site area.

Parameters

The parameters for this activity are

1. Length, location, and spatial orientation of faults.
2. Segmentation within individual faults.
3. Width of faults.
4. Age and nature of Quaternary deposits and Quaternary surfaces displaced by or covering Quaternary faults within the site area.
5. Location, amount, and direction of displacement of Quaternary deposits and Quaternary surfaces.
6. Age, lateral extent, and height of fault scarps.
7. Lineaments with expression in surficial deposits.

Description

This activity focuses on the (1) synthesis and evaluation of data pertaining to the length, age, recurrence rate, and displacement rate of faults within the site area; (2) search of the site area for hitherto unrecognized Quaternary faults; and (3) determination of the distribution of surficial deposits within the site area. The principal vehicle for accomplishing these objectives is through the preparation of 1:24,000-scale maps of the site area, one with emphasis on Quaternary faults (to be compiled in this activity), and the other with emphasis on surficial deposits (to be compiled in Activity 8.3.1.5.1.4.3). The fault map will depict the location and extent of faults, as well as the amount and timing of displacement of Quaternary datums.

CONSULTATION DRAFT

Calculation of rates of faulting requires delineation of areas within which recognition of pre-Holocene faulting would not be possible because of cover by Holocene deposits. To satisfy this requirement, Holocene deposits of Yucca Mountain will be accurately mapped at 1:24,000 scale.

Surficial deposits mapping of Yucca Mountain. In Activity 8.3.1.5.1.4.3, existing unpublished maps of surficial deposits at Yucca Mountain will be reviewed and upgraded, then compiled at a scale of 1:24,000. Surficial deposits along known Quaternary faults extending outside the site area will be mapped in conjunction with investigations of those specific faults. This subactivity is 25 percent complete. Duration of future work estimated to be two years.

Quaternary fault map of Yucca Mountain. In this activity, Quaternary faults will be mapped at a scale of 1:24,000. Information will be compiled from existing geologic mapping (Scott and Bonk, 1984) and all Quaternary faults will be examined in the field to determine the age of youngest offset Quaternary deposits. Information on the age and recurrence intervals of individual faults will be added to the map from detailed trench studies described in Activity 8.3.1.17.4.6.2 (evaluate age and recurrence of movement on suspected and known Quaternary faults). The map will be periodically updated as other studies of faults are completed and released in final form when site characterization is completed.

Methods and technical procedures

The methods and technical procedures for Activity 8.3.1.17.4.6.1 are given in the following table.

Method	Technical procedure		
	Number	Title	Date
	(NWM-USGS-)		
Surficial deposits mapping of Yucca Mountain	GP-01, RO	Geologic mapping	1 Mar 83
	GP-03, RO	Stratigraphic studies	1 Mar 83
Quaternary fault map of Yucca Mountain	GP-01, RO	Geologic mapping	1 Mar 83
	GP-03, RO	Stratigraphic studies	1 Mar 83
	GP-04, RO	Structural studies	1 Mar 83
	GP-07, RO	Geologic trenching studies	14 Aug 84
	GCP-01, RO	Radiometric-age data bank	15 June 81
	GCP-02, RO	Labeling, identification and control of samples for geochemistry and isotope geology	20 Jan 87

CONSULTATION DRAFT

Method	Technical procedure		
	Number	Title	Date
	GCP-04, RO	Uranium-trend dating	15 June 81
	TBD	Cation ratio dating	TBD
	TBD	Thermoluminescence dating	TBD
	TBD	Radio carbon dating	TBD
	TBD	Low-angle photography	TBD

8.3.1.17.4.6.2 Activity: Evaluate age and recurrence of movement on suspected and known Quaternary faults

Objectives

The objectives of this activity are to

1. Determine, through trenching and mapping, the location, spatial orientation, length, width, Quaternary recurrence rate, interconnections at the surface, and the location, amount, and nature of Quaternary movement of the Paintbrush Canyon, Solitario Canyon, Windy Wash, and Ghost Dance faults, and other suspected or possible Quaternary faults within the site area.
2. Determine through trenching and dating, the age, amount and nature of offset, and the recurrence history of the Bow Ridge fault system and to evaluate that information in context with data contributed by other studies on the age, nature, and origin of fracture coatings and fissure fillings deposited within that zone.

Parameters

The parameters for this activity are

1. Length, location, and spatial orientation of faults.
2. Segmentation within individual faults.
3. Width of faults.
4. Age and nature of Quaternary deposits and Quaternary surfaces displaced by or covering Quaternary faults within the site area.
5. Location, amount, and direction of displacement of Quaternary deposits and Quaternary surfaces.
6. Age, lateral extent, and height of fault scarps.

CONSULTATION DRAFT

7. Age of soils overlapping or displaced by faults.
8. Age of volcanic ashes intercalated in surficial deposits that overlap or are displaced by faults, or that have filled fissures within the fault zones.

Description

This activity is designed (1) to characterize, through geologic mapping and trenching, potentially significant Quaternary faults in the Yucca Mountain area, and (2) to define interconnections between these faults at the surface. The Paintbrush Canyon, Bow Ridge, Windy Wash, and Solitario Canyon fault zones are zones where multiple episodes of Quaternary movement are suspected, hence have been singled out for special attention. Other suspected or possible Quaternary faults will be examined and their potential significance to design or performance issues will be evaluated. Trenching at locations to be determined may be required to assess the significance of these faults.

Dating of fault movement depends on accurate determination of the age of soils and other deposits cut by the fault and the age of vein materials deposited in fissures along the fault surface. These materials are to be dated by uranium-trend, cation ratio, and radiocarbon methods, and the methods themselves will be calibrated by dating deposits of known age elsewhere within the immediate region. The ages of soils are to be established through quantitative chemical and physical comparison with soil development indexes established within Activity 8.3.1.5.1.4.1 (modeling of soil properties in the Yucca Mountain region).

Where exact ages are difficult to measure, relative ages can commonly be determined through stratigraphic correlation of deposits involved in the faulting. Stratigraphic correlation is planned at two scales; large-scale, detailed stratigraphic mapping of surficial deposits of Yucca Mountain (to be contributed by Activity 8.3.1.17.4.6.1--evaluate Quaternary geology and potential Quaternary faults at Yucca Mountain), and medium-scale regional stratigraphic mapping of surficial deposits of the Beatty 1:100,000 quadrangle (to be contributed by Activity 8.3.1.17.4.3.2--evaluate Quaternary faults within 100 km of Yucca Mountain).

Volcanic ashes are commonly intercalated within the Quaternary deposits, as at Busted Butte. Their identification, correlation, and dating depends on chemical fingerprinting and recognition of the source eruptions of the ash, which typically are volcanic centers in the eastern Sierra Nevada, Yellowstone, or Cascades. Volcanic ashes from the Yucca Mountain area will be collected and chemically analyzed, and the analyses compared with analyses of reference samples from the western United States.

Mapping and analysis of offset of Quaternary datums in trenches and outcrop (Paintbrush Canyon fault zone). Quaternary deposits and faults within and proximal to the Paintbrush Canyon fault zone, including the Busted Butte area will be mapped using conventional field methods. Existing trenches (see Figure 8.3.1.17-11 for location) across fault traces and scarps will be supplemented with two to four additional trenches in the Busted Butte area. The distribution of Quaternary datums, rupture zones, fracture zones,

CONSULTATION DRAFT

and fracture fillings in trenches will be mapped. Datums will be sampled and their age determined through appropriate procedures, including uranium-trend, uranium-series, soil development, and ash correlation. The work is 25 percent completed, and the duration of the future work is estimated to be two years.

Analysis of offset of Quaternary datums in trenches (Bow Ridge fault system, Yucca Mountain area). The distribution of Quaternary datums, rupture zones, fracture zones, and fracture and fissure fillings will be mapped at large scale in trenches excavated across the fault zone. The orientation of fractures and slickensides for paleostress determination will be recorded. Age of datums, fracture coatings and fissure fillings will be determined through appropriate procedures, including uranium-trend, uranium-series, soil development, and thermoluminescence. Vein material and fracture coatings will be identified using standard petrographic techniques, x-ray diffraction and x-ray fluorescence analyses, wet-chemical analyses, and oxygen-isotope analyses. The fault has been trenched at two locations (Figure 8.3.1.17-11) and logging of these trenches is 50 percent completed. Provided suitable locations can be found, one or two additional trenches may be excavated. The duration of the future work is estimated to be one year.

Mapping and analysis of offset of Quaternary datums in trenches and out-crop (Windy Wash fault zone). Quaternary deposits and faults within and proximal to the Windy Wash fault zone will be mapped using conventional field methods. Fault traces and scarps will be trenched. The distribution of Quaternary datums, rupture zones, fracture zones, and fracture fillings in trenches will be mapped. Datums will be sampled and their age determined through appropriate procedures, including uranium-trend, uranium-series, thermoluminescence, soil development, and ash correlation. Two trenches have been excavated and logged (Figure 8.3.1.17-11). Additional trenching at these same locations is planned to define the strike-slip component of offset. The duration of the future work is estimated to be one year.

Mapping and analysis of offset of Quaternary datums in trenches and out-crop (Ghost Dance fault zone). Quaternary deposits and faults within and proximal to the Ghost Dance fault zone will be mapped using conventional field methods.

The distribution of Quaternary datums, rupture zones, fracture zones, and fracture and fissure fillings will be mapped at large scale in trenches excavated across the fault zone. The orientation of fractures and slickensides for paleostress determination will be recorded. Age of datums, fracture coatings, and fissure fillings will be determined through appropriate procedures, including uranium-trend, uranium-series, soil development, and thermoluminescence. Five trenches have been excavated along or near the fault zone without revealing definitive data on Quaternary movement. Provided suitable locations can be found, two additional trenches are planned. The duration of the future work is estimated to be one year.

Mapping and analysis of offset of Quaternary datums in trenches and out-crop (Solitario Canyon fault zone). Quaternary deposits and faults within and proximal to the Solitario Canyon fault zone will be mapped using conventional field methods.

CONSULTATION DRAFT

The distribution of Quaternary datums, rupture zones, fracture zones, and fracture and fissure fillings will be mapped at large scale in trenches excavated across the fault zone. The orientation of fractures and slickensides for paleostress determination will be recorded. Age of datums, fracture coatings, and fissure fillings will be determined through appropriate procedures, including uranium-trend, uranium-series, soil development, and thermoluminescence. Six trenches have been excavated across the trace of the fault (Figure 8.3.1.17-11). Provided suitable locations can be found, one to two additional trenches will be excavated. The duration of the future work is estimated to be six months.

Uranium-trend and uranium-series dating of Quaternary datums and fracture fillings. Samples of alluvium, colluvium, altered volcanic ash, eolian deposits, and fracture fillings will be collected. Uranium-trend (open-system) methods will be used to date the samples, except for fracture fillings, which will be dated by uranium-series (closed-system) methods. Deposits of 5,000 to 800,000 yr in age will use open-system techniques. Four to ten samples will be collected at different depths in a depositional unit or in the soil profile formed in a depositional unit. Isotopic concentrations of uranium and thorium will be determined by alpha spectrometry using radioisotope dilution techniques. Analytical results will be plotted as ratios, yielding a linear array in which the slope of the line-of-best-fit depends on the age of the deposit. Age of the samples will be found empirically through comparison with results from similar deposits dated by other methods.

The dating effort will be focused on (1) collecting and analyzing samples of units of unknown age at Yucca Mountain and vicinity that are cut by or overlap faults and also are key marker beds within the Beatty 1:100,000 quadrangle, and (2) collecting and analyzing samples of units of known age within the region to calibrate the method. This subactivity will be conducted on an as-needed basis to support the analyses in this activity.

Quaternary volcanic ash correlation and dating. Glass shards from bulk samples of ash intercalated in Quaternary deposits cut by or overlapping Quaternary faults will be separated. The glass will be chemically analyzed using microprobe and standard neutron activation and x-ray fluorescence procedures. Analytical data will be compared with that of known and well-dated ashes within the region. Biotite, muscovite, and zircon from bulk samples of ashes intercalated in Quaternary and older deposits will be dated with potassium-argon dating method or fission-track techniques, as appropriate, where these minerals are present in the sample. This subactivity will be conducted on an as-needed basis to support the analyses in this activity.

Methods and technical procedures

The methods and technical procedures for Activity 8.3.1.17.4.6.2 are given in the following table.

CONSULTATION DRAFT

Method	Technical procedure		
	Number	Title	Date
(NWM-USGS-)			
Mapping and analysis of offset of Quaternary datums in trenches and outcrop (Paintbrush Canyon fault zone)	GP-01, RO	Geologic mapping	1 Mar 83
	GP-03, RO	Stratigraphic studies	1 Mar 83
	GP-04, RO	Structural studies	1 Mar 83
	GP-07, RO	Geologic trenching studies	14 Aug 84
	GP-17, RO	Describing and sampling soils in the field	19 Feb 86
	GCP-01, RO	Radiometric-age data bank	15 June 81
	GCP-02, R1	Labeling, identification, and control of samples for geochemistry and isotope geology	20 Jan 87
	GCP-03, RO	Uranium-series dating	15 June 81
	GCP-04, RO	Uranium-trend dating	15 June 81
	TBD ^a	Thermoluminescence	TBD
Analysis of offset of Quaternary datums in trenches (Bow Ridge fault system, Yucca Mountain area)	GP-01, RO	Geologic mapping	1 Mar 83
	GP-03, RO	Stratigraphic studies	1 Mar 83
	GP-04, RO	Structural studies	1 Mar 83
	GP-07, RO	Geologic trenching studies	14 Aug 84
	GP-17, RO	Describing and sampling soils in the field	19 Feb 86
	GCP-01, RO	Radiometric age data bank	15 June 81
	GCP-02, R1	Labeling, identification, and control of samples for geochemistry and isotope geology	20 Jan 87
	GCP-03, RO	Uranium-series dating	15 June 81
	GCP-04, RO	Uranium-trend dating	15 June 81
	TBD	Thermoluminescence dating	TBD
	TBD	X-ray diffraction analysis	TBD
	TBD	X-ray fluorescence analysis	TBD
	TBD	Wet-chemical analysis	TBD
TBD	Oxygen-isotope analysis	TBD	

CONSULTATION DRAFT

Method	Technical procedure		
	Number	Title	Date
Mapping and analysis of offset of Quaternary datums in trenches and outcrop (Windy Wash fault zone)	GP-01, RO	Geologic mapping	1 Mar 83
	GP-03, RO	Stratigraphic studies	1 Mar 83
	GP-04, RO	Structural studies	1 Mar 83
	GP-08, RO	Correlation of tephra by means of chemical analysis	17 Feb 86
	GP-17, RO	Describing and sampling soils in the field	19 Feb 86
	GCP-01, RO	Radiometric-age data bank	15 June 81
	GCP-02, R1	Labeling, identification and control of samples for geochemistry and isotope geology	20 Jan 87
	GCP-03, RO	Uranium-series dating	15 June 81
	GCP-04, RO	Uranium-trend dating	15 June 81
	TBD	Thermoluminescence	TBD
Mapping and analysis of offset of Quaternary datums in trenches and outcrop (Ghost Dance fault zone)	GP-01, RO	Geologic mapping	1 Mar 83
	GP-03, RO	Stratigraphic studies	1 Mar 83
	GP-04, RO	Structural studies	1 Mar 83
	GP-08, RO	Correlation of tephra by means of chemical analysis	17 Feb 86
	GP-17, RO	Describing and sampling soils in the field	19 Feb 86
	GCP-01, RO	Radiometric-age data bank	15 June 81
	GCP-02, R1	Labeling, identification and control samples for geochemistry and isotope geology	20 Jan 87
	GCP-03, RO	Uranium-series dating	15 June 81
	GCP-04, RO	Uranium-trend dating	15 June 81
	TBD	Thermoluminescence	TBD
Mapping and analysis of offset of Quaternary datums in trenches and outcrop (Solitario Canyon fault zone)	GP-01, RO	Geologic mapping	1 Mar 83
	GP-03, RO	Stratigraphic studies	1 Mar 83
	GP-04, RO	Structural studies	1 Mar 83
	GP-08, RO	Correlation of tephra by means of chemical analysis	17 Feb 86
	GP-17, RO	Describing and sampling soils in the field	19 Feb 86
	GCP-01, RO	Radiometric-age data bank	15 June 81

CONSULTATION DRAFT

Method	Technical procedure		Date
	Number	Title	
	GCP-02, R1	Labeling, identification and control of geochronology samples and separates	20 Jan 87
	GCP-03, RO	Uranium-series dating	15 June 81
	GCP-04, RO	Uranium-trend dating	15 June 81
	TBD	Thermoluminescence	TBD
Uranium-trend and uranium-series dating of Quaternary datums and fracture fillings	GCP-01, RO	Radiometric-age data bank	15 June 81
	GCP-02, R1	Labeling, identification, and control of samples for geochemistry and isotope geology	20 Jan 87
	GCP-03, RO	Uranium-series dating	15 June 81
	GCP-04, RO	Uranium-trend dating	15 June 81
	TBD	Isotopic uranium and thorium concentrations using alpha spectrometry	TBD
Quaternary volcanic ash correlation and dating	GCP-01, RO	Radiometric-age data bank	15 June 81
	GCP-02, R1	Labeling, identification and control of samples for geochemistry and isotope geology	20 Jan 87
	GCP-06, RO	Potassium-argon dating	15 June 81
	GCP-08, RO	Fission-track dating	15 June 81
	TBD	Microprobe analysis	TBD
	TBD	Neutron activation analysis	TBD
	TBD	X-ray fluorescence	TBD
	TBD	Ash fingerprinting	TBD

^aTBD = to be determined.

8.3.1.17.4.7 Study: Subsurface geometry and concealed extensions of Quaternary faults at Yucca Mountain

The objectives of this study are to (1) provide data on distribution of mass, magnetic gradients, geoelectric features, and seismic velocities and

CONSULTATION DRAFT

reflections that will aid in evaluating the continuity of Quaternary faults where concealed by Holocene and late Pleistocene surficial deposits; (2) evaluate that data and its limitations; and (3) evaluate the possibility that Quaternary faults exposed as high-angle faults at the site continue to depth as planar, high-angle faults, or alternatively, flatten at depth and merge with one or more low-angle faults. The geophysical methods used in this study measure rock properties (mass, magnetism, electrical resistivity, gamma radiation), sensing faults as discontinuities in those properties. The same methods are therefore useful in solving the converse problem, determination of continuity of rock units at the site. A third objective, then, is to provide information on continuity of rock units within the repository and controlled area to assist the investigation of site geology (Section 8.3.1.4).

Activities planned for this study include (1) evaluation of intermediate depth (2 to 3 km) reflection and refraction methods and planning of potential application of these methods at the site; (2) detailed gravity survey of the site; (3) detailed aeromagnetic survey of the site; (4) detailed ground magnetic surveys of specific features at the site; (5) evaluation of surface geoelectric methods and planning of potential applications of these methods at the site; (6) evaluation of methods to detect buried faults using gamma ray measurements, and conduct an airborne gamma-ray survey of the site; (7) evaluation of thermal infrared methods and planning for potential applications of these methods at the site; and (8) shallow seismic reflection (mini-sosie) survey of selected structures at and proximal to the site. These and other geophysical methods being applied in other studies which contribute to site and regional tectonic and geologic problems are listed in Tables 8.3.1.17-7 and -8. Synthesis of the geophysical data is to be done in Study 8.3.1.17.4.12 (tectonic models and synthesis).

8.3.1.17.4.7.1 Activity: Evaluate intermediate depth (2 to 3 km) reflection and refraction methods and plan potential application of these methods within the site area

Objectives

The objectives of this activity are to (1) evaluate previous attempts to use seismic refraction and reflection methods at the site, (2) evaluate technology currently available, (3) evaluate potential contribution to information on velocity structure and on subsurface geometry of faults, (4) review potential applications of these methods to NNWSI Project needs, and (5) if appropriate, plan applications of these methods at the site.

Parameters

Parameters for this activity are

1. Seismologic reflections and discontinuities.
2. Seismic velocity structure.

CONSULTATION DRAFT

Description

A previous attempt to apply reflection seismology using Vibroseis energy source at Yucca Mountain failed to produce useful results (McGovern, 1983). More recent surveys at Mid Valley using an air gun energy source produced excellent reflections to 1.5 s (two-way travel time), resulting in satisfactory resolution of faults and thickness and inclination of subsurface units. These results will be reviewed and their potential application to the site evaluated. If appropriate, a reflection and refraction survey of the site will be planned. The expected duration of this activity is three months.

This is a planning activity only. Decision to proceed with actual application of these methods is contingent on results of the evaluation, technical peer review and review of potential applications to NNWSI Project needs.

Methods and technical procedures

The methods and procedures for Activity 8.3.1.17.4.7.1 are given in the following table.

Method	Technical procedure		
	Number	Title	Date
Evaluation of intermediate depth (2 to 3 km) reflection and refraction methods and planning of potential application of these methods at the site	TBD ^a	TBD	TBD

^aTBD = to be determined.

8.3.1.17.4.7.2 Activity: Detailed gravity survey of the site area

Objectives

The objectives of this activity are to measure variations in mass of near-surface strata and surficial deposits, and to infer from this information the location of faults and continuity of rock units within the site.

CONSULTATION DRAFT

Parameters

The parameters for this activity are gravity gradients and anomalies at the site.

Description

The gravity maps of the site currently available are based on gravity observations that are too widely spaced to be useful in discrimination of faults or demonstration of continuity of rock units. In this activity, a 1:24,000-scale map of the site will be constructed from gravity observation at stations spaced 200 ft apart along east-west lines spaced 500 ft apart (where topography permits). The expected duration of this activity is one year.

Methods and technical procedures

The method and technical procedure for Activity 8.3.1.17.4.7.2 is given in the following table.

Method	Number	Technical procedure	Date
		Title	
Detailed gravity survey of the site area	GPP-01, R1	Gravity measurement and data reduction	14 Jan 85

8.3.1.17.4.7.3 Activity: Detailed aeromagnetic survey of the site area

Objectives

The objectives of this activity are to measure variations in rock magnetism of surface strata and surficial deposits and to infer from this information the location of faults and continuity of rock units within the site.

Parameters

The parameters for this activity are magnetic gradients and anomalies at the site.

Description

The aeromagnetic maps of the site currently available are based on measurement of magnetic field along flight lines at 1/4-mile spacing. These observations are too widely spaced to resolve ambiguities in fault continuity

CONSULTATION DRAFT

or to demonstrate the continuity of rock units. In this activity, a 1:12,000-scale map of the site will be constructed from measurement of the magnetic field along east-west flight lines spaced 1/16 mile apart. The survey will be draped over topography, maintaining a nominal terrain clearance of 400 ft. The expected duration of this activity is one year.

Methods and technical procedures

The methods and technical procedures for Activity 8.3.1.17.4.7.3 are given in the following table.

Method	Number	Technical procedure	
		Title	Date
Detailed aeromagnetic survey of the site	TBD ^a	Airborne magnetic surveying	TBD

^aTBD = to be determined.

8.3.1.17.4.7.4 Activity: Detailed ground magnetic survey of specific features within the site area

Objectives

The objectives of this activity are (1) to measure variations in rock magnetism of surface strata and surficial deposits in the vicinity of specific faults, the shaft and surface facilities, drillholes, and aeromagnetic anomalies, and (2) to infer from this information the location of faults and continuity of rock units at these locations.

Parameters

The parameters for this activity are magnetic gradients and anomalies at specified locations.

Description

In this activity, the magnetic field in the vicinity of specific features (Figure 8.3.1.4-9) will be measured from truck-mounted or hand-carried magnetometers. Observations will be semicontinuous (10- to 20-ft intervals). The classes of features at which these measurements will be made include (1) known and inferred structures, (2) vicinity of drillholes, (3) vicinity of shaft and surface facilities, and (4) vicinity of anomalies detected through aeromagnetic surveying (Activity 8.3.1.17.4.7.3). Not all such features will be surveyed. The number and location of those selected

CONSULTATION DRAFT

for investigation using this method will be determined by principal investigators as the need arises through evaluation of geologic and geophysical mapping.

Methods and technical procedures

The method and technical procedure for Activity 8.3.1.17.4.7.4 is given in the following table.

Method	Number	Technical procedure	
		Title	Date
Detailed ground magnetic surveys	GP-05, R0	Geologic support activities	01 Mar 83

8.3.1.17.4.7.5 Activity: Evaluate surface geoelectric methods and plan potential applications of these methods within the site area

Objectives

The objectives of this activity are to (1) evaluate previous attempts to use surface geoelectric methods at the site, (2) evaluate technology currently available, (3) evaluate the potential contribution of these methods to definition of subsurface geometry of faults, (4) review potential applications of these methods to NNWSI Project needs, and (5) if appropriate, plan future applications of these methods at the site.

Parameters

The parameters for this activity are

1. Sensitivity and resolution of geoelectric field measurements.
2. Correlation of geoelectric measurements with faults and rock properties.

Description

Surface-based geoelectric investigations, including airborne electromagnetic slingram, VLF, DC resistivity, electromagnetic soundings, tensor audio magnetotellurics, and telluric profiling have been applied to site and regional geologic problems (refer to the references in Table 8.3.1.17-7 and -8). Results of these investigations and the status of current technology will be reviewed and their potential application to structural and stratigraphic problems at the site evaluated. If appropriate, surface-based

CONSULTATION DRAFT

geoelectric investigations at site will be planned. Expected duration of this activity is three months.

This is a planning activity only. The decision to proceed with actual application of these methods is contingent on the results of the evaluation and a review of potential applications to NNWSI Project needs.

Methods and technical procedures

The methods and technical procedure for Activity 8.3.1.17.4.7.6 are given in the following table.

Method	Technical procedure		
	Number	Title	Date
Evaluation of surface geoelectric methods and planning of potential applications of these methods within the site area	TBD ^a	TBD	TBD

^aTBD = to be determined.

8.3.1.17.4.7.6 Activity: Evaluate methods to detect buried faults using gamma-ray measurements, and plan potential application of these methods within the site area

Objectives

The objectives of this activity are (1) to evaluate the feasibility of using surface and airborne gamma-ray measurements to detect and discriminate faults at the site, (2) to review potential applications of these methods to Project needs, and (3) if appropriate, conduct an airborne radiometric survey for that purpose as an adjunct to the aeromagnetic survey of the site.

Parameters

The parameters for this activity are

1. Sensitivity and resolution of surface and airborne gamma-ray measurements.
2. Correlation of gamma-ray gradients and anomalies with faults and rock properties.

CONSULTATION DRAFT

Description

The principal natural sources of gamma radiation are uranium, thorium, potassium, and radon gas. Because gamma-ray measurements (aerial or ground) detect gamma rays from the uppermost 50 cm of rock and soil, to be detectable buried faults must have a near-surface expression that is reflected in the near-surface distribution of the natural radioelements. In the site area, the Tiva Canyon and Topopah Spring members are potassium- and thorium-rich volcanic rocks. Gamma-ray spectral logs show typically 4 percent potassium, 6 ppm uranium and 30 ppm thorium for these rock units. Reconnaissance airborne gamma-ray surveys show that colluvium derived from these volcanic rocks, as along Fortymile Wash, has essentially the same signature as the rocks themselves.

To be detectable, buried faults must be reflected by near-surface radioelement distributions, perhaps arising through migration of uranium or potassium along the fault zone through percolation of meteoric water, or through percolation of radon from the fault to the surface in sufficient quantities to be detected by gamma-ray measurements.

In this activity, the possibility that buried faults can be detected will be evaluated through measurement of gamma rays using portable quantitatively calibrated gamma-ray spectrometers along several short (100 m long) traverses crossing buried extensions of the Paintbrush Canyon, Bow Ridge, Windy Wash, and Stagecoach Road faults. If results of these tests so warrant, an airborne radiometric survey will be conducted as an adjunct to the detailed aeromagnetic survey. Expected duration of this activity is three months.

This is a planning activity only. The decision to proceed with actual application of these methods is contingent on the results of the evaluation and a review of potential applications to NNWSI Project needs.

Methods and technical procedures

The methods and technical procedures for Activity 8.3.1.17.4.7.6 are given in the following table.

Method	Technical procedure		Date
	Number	Title	
Evaluation of methods to detect buried faults using gamma-ray measurement	TBD ^a	TBD	TBD

^aTBD = to be determined.

8.3.1.17.4.7.7 Activity: Evaluate thermal infrared methods and plan potential applications of these methods within the site area

Objectives

The objectives of this activity are to evaluate current thermal infrared survey technology, evaluate its potential application to remote mapping of fractures and faults at Yucca Mountain, review potential applications of these methods to Project needs, and if appropriate, plan future applications of these methods at the site.

Parameters

The parameters for this activity are

1. Sensitivity and resolution of remote thermal infrared survey methods.
2. Correlation of thermal infrared signature with faults and fractures.

Description

Fractures and faults at Yucca Mountain are potential conduits for percolation of meteoric waters. Surface temperature variation associated with differing moisture content of near-surface material is detectable through thermal imaging from aircraft or satellites, and hence it may be possible to map the fault and fracture network at Yucca Mountain using remote thermal infrared sensing methods. In this activity, existing technology and its application to detection of faults and fractures, and water percolation pattern at the site will be evaluated. If appropriate, application of remote thermal infrared techniques to these problems will be planned. The expected duration of this activity is three months.

This is a planning activity only. The decision to proceed with the actual application of these methods is contingent on results of the evaluation and review of potential applications to NNWSI Project needs.

Methods and technical procedures

The methods and technical procedures for Activity 8.3.1.17.4.7.7 are given in the following table.

Method	Technical procedure		
	Number	Title	Date
Evaluation of thermal infrared methods and planning of potential applications of these methods at the site	TBD ^a	TBD	TBD

^aTBD = to be determined.

CONSULTATION DRAFT

8.3.1.17.4.7.8 Activity: Evaluate shallow seismic reflection (mini-sosie) methods and, if appropriate, conduct surveys of selected structures at and proximal to the site area

Objectives

The objectives of this activity are to evaluate the subsurface configuration of selected Quaternary faults and the lateral continuity and inclination of key beds within the Miocene volcanic sequence at the northeastern, eastern, and southwestern parts of the site area.

Parameters

The parameters for this activity are

1. Seismic reflections in the vicinity of selected faults.
2. Seismic reflections in the northeastern, eastern, and southwestern parts of the site.
3. Seismic velocity structure at and proximal to the site.

Description

Shallow seismic reflection (mini-sosie) has proved to be a rapid and economical method of defining subsurface geometry within the uppermost 1 km of the crust in some areas. However, previous attempts to use the method in the vicinity of the site have produced somewhat ambiguous results. The method has previously been used in defining the subsurface extent of the Beatty scarp and the Rock Valley fault, and fieldwork has been completed on traverses crossing the Bare Mountain range front fault, and the central part of Crater Flat (Figure 8.3.1.4-8).

Nine additional profiles have been proposed (Figure 8.3.1.4-8), all but one of which are within the site area. Two of these (Jackass Flats and Fran Ridge traverses) are designated as preliminary traverses. Each begins and ends at drillholes, providing opportunity to tie the reflections to known beds. If acceptable results are achieved in the preliminary tests, the remaining profiles will be run.

The method uses portable instruments, 9.1-m source point (data stacked at common midpoints every 4.6 m at 12-fold, or every 9.1 m at 24-fold) with 12 geophones per group. The energy source is a battery of hand-held construction tampers.

This is an activity to evaluate the suitability of the technique. The expected duration of this activity is three months. The decision to proceed with full-scale application of the method is contingent on results of the evaluation.

Methods and technical procedures

The methods and procedures for Activity 8.3.1.17.4.7.8 are given in the following table.

CONSULTATION DRAFT

Method	Technical procedure		Date
	Number	Title	
Shallow seismic reflection (mini-sosie) survey of selected structures at and proximal to the site	TBD ^a	TBD	TBD

^aTBD = to be determined.

8.3.1.17.4.8 Study: Stress field within and proximal to the site area

Objectives

The primary objective of this study is to provide data on the ambient stress at the site and its immediate vicinity that will aid in evaluating (1) the most favored orientation and nature of future movement on faults within the site area, (2) the stability of potential pathways for radionuclide travel controlled by or related to fracture aperture, (3) the stability of mined excavations, (4) the response of the rock mass to thermal loading, and (5) the applicability of tectonic models. A secondary objective is to evaluate the potential relevance of paleostress data to prediction of future stress orientations.

For convenience, the larger and smaller components of the principal stresses in the horizontal plane are referred to as S_H and S_h , respectively, and the component of the principal stresses in the vertical plane as S_v . At Yucca Mountain, the average direction S_h is approximately N.60W., on the basis of in situ stress determinations (Stock et al., 1985). This direction is in reasonable agreement with the average orientation of the stress field in the Yucca Mountain region based on focal plane solutions of recent earthquakes and on in situ stress determinations at Rainier Mesa. However, to the west, in the Coso Volcanic Field, the average direction of S_h is approximately east-west (Walter and Weaver, 1980). The exact location and nature of the transition from N.60W. at Yucca Mountain to east-west in the area west of Death Valley is unknown.

The in situ measurements at Yucca Mountain indicate the $S_h < S_H < S_v$, with the magnitude of S_h near the failure criterion for dip-slip failure on N.30E.-trending faults and so low that the aperture of favorably oriented fractures is sensitive to hydrostatic pressure of the fluid column in boreholes (Ellis and Swolfs, 1983). However, most of the focal-plane solutions of recent earthquakes within the immediate region of Yucca Mountain indicate predominantly strike-slip movement on north-trending faults, suggesting that $S_h < S_v < S_H$. Additional study is required to verify the compatibility or lack of it for these two data sets and to evaluate their potentially

CONSULTATION DRAFT

conflicting implications pertaining to rupture, ground motion, and tectonic effects on hydrology.

Possibly the in situ measurements are only characteristic of a shallow part of the lithospheric crust, a part that is decoupled from deeper parts by one or more detachment faults. Such a zone of decoupling may distinguish active from inactive detachment faults. It follows that subsurface extensions of detachment faults forming the contact between Miocene and Paleozoic rocks north of Mercury, and at the northern flank of Bare Mountain, and at the southern edge of the Bullfrog Hills may be zones of mechanical decoupling between upper plate and lower plates. If so, stress regimes above and below such zones may be quite distinct; this possibility will be evaluated in Activity 8.3.1.17.4.8.4

In addition to the possible complications of the regional stress pattern arising from the potential presence of detached plates, other complications may result from the apparent organization of the upper crust as a mosaic of structurally distinct blocks. The Yucca Mountain region appears to be an aggregation of such blocks, including for example, the blocks corresponding to the northern Amargosa Desert, the Bare Mountain, the Yucca Mountain, and the Little Skull Mountain areas. The orientation and degree of development of Neogene and Quaternary structures appear to vary from block to block.

The structural grain of some blocks, such as Little Skull Mountain, appears to be rotated 30 degrees clockwise from the regional trend, a feature known to be characteristic of bedrock terranes adjacent to the Walker Lane. The appearance of rotation probably reflects both a physical rotation about a vertical axis (the oroflexural bending of Albers, 1967) and, during the time the blocks were actively rotating, sharp curvature of stress trajectories crossing or curving into the Walker Lane. Investigation of ambient stress and paleostress at Yucca Mountain and vicinity should help evaluate the applicability of these and other tectonic models to the neotectonics of the site.

Activities planned for this study include (1) an evaluation of the effectiveness of shallow borehole hydrofrac and triaxial strain recovery methods for the determination of in situ stress and their potential application to determination of the stress field proximal to the site, (2) an evaluation of the present stress field at the site, (3) an evaluation of the published and unpublished data on paleostress orientation at and proximal to the site and an assessment of the relevance of this data to future stress orientations, and (4) an evaluation of theoretical stress distributions associated with potential tectonic settings (e.g., wrench fault, normal fault, and detachment fault setting) of the site.

Rationalization of the stress and strain at the site in relation to the plate-tectonic setting and applicable tectonic models will be performed in Study 8.3.1.17.4.12 (regional tectonic models and synthesis). In situ stress determinations will also be made in the exploratory shaft facility. Refer to Activity 8.3.1.4.3.1.1 for a description of these tests. Paleostress indicators in the form of fractures and slickenside lineations will also be evaluated in the exploratory shaft facility. Refer to Activity 8.3.1.4.2.2.4 for a description of this activity.

CONSULTATION DRAFT

8.3.1.17.4.8.1 Activity: Evaluate present stress field within the site area

Objectives

The objective of this activity is to measure the vertical and lateral variation of in situ stress at the site, including the variation of in situ stress in one borehole that is intended to intersect a postulated detachment fault below Yucca Mountain.

Parameters

The parameters for this procedure are

1. The magnitude of in situ stress.
2. The orientation of induced fractures and borehole breakouts.

Description

In situ stress measurements at the site have previously been made in drillholes USW G-1, USW G-2, USW G-3, and UE-25p#1 (Figure 8.3.1.4-5). These measurements suggest that the least principal horizontal stress (S_h) is oriented about N.60°W., and that at depths up to one kilometer $S_h < S_H < S_v$, indicating a normal faulting stress regime. On the basis of focal plane solutions for recent earthquakes, however, the deep (greater than 1-km depth) stress field in the region encompassing the site is believed to be characterized by strike-slip faulting. This is contrary to the general observation, reported in Chapter 1, that the stress field in the Great Basin province is characterized by a strike-slip regime near the surface and a normal faulting regime at depth (Vetter and Ryall, 1983).

This activity is designed to contribute to the characterization of in situ stress at the site through hydrofrac measurements and analysis of borehole breakouts in three boreholes (USW G-5, USW G-6 and USW G-7, Figure 8.3.1.4-5) to be drilled for other purposes. It is intended that borehole G-7 will pass through a postulated detachment. The duration is contingent on drilling schedule for these holes, but is estimated to be one to two years. Vertical variation of in situ stress will be evaluated through collection of hydrofrac measurements at six to ten depth intervals within each well.

Methods and technical procedures

The method and procedure for Activity 8.3.1.17.4.8.1 is given in the following table.

Method	Technical procedure		
	Number	Title	Date
Deep borehole in situ stress tests	GPP-04, RO	In situ stress investigations	27 June 83

CONSULTATION DRAFT

8.3.1.17.4.8.2 Activity: Evaluate and test shallow borehole hydrofrac and triaxial strain recovery methods for the determination of in situ stress, and if appropriate, plan potential application of these methods within and proximal to the site

Objectives

The objectives of this activity are to

1. Evaluate the usefulness of shallow borehole hydrofrac and triaxial strain recovery methods for the determination of in situ stress.
2. Measure the lateral variation of in situ stress in areas proximal to the site.
3. Measure vertical variation in stress above and below the possible detachment between Miocene and Paleozoic rocks east of Yucca Mountain in the Little Skull Mountain or Striped Hills area.

Parameters

The parameters of this activity are

1. Magnitude of in situ stress.
2. Orientation of induced fractures and borehole breakouts.
3. Triaxial strain in oriented samples of drill core.

Description

The orientation and magnitude of the principal stresses at any particular place are apt to vary from the regional average as a result of location with respect to boundaries of structural blocks, zones of active dislocation, and possible differences in end loads and tractive forces at the base of the crustal blocks. For this reason, it is possible that in situ stress determinations could contain considerable information about the manner in which the upper crust in the vicinity of the site is deforming. However, the in situ stress at any point is also influenced by local elastic properties, topographic effects, local discontinuities, and previous history of deformation. The hydrofrac measurements must therefore be interpreted with caution, and several measurements at varying depth must be made to be confident of the result.

This activity is designed to examine the vertical variation in stress at two drillholes, one within the site area, the other east of the site in the Little Skull Mountain or Striped Hills area. Measurements at the site, using a shallow borehole (drilled for other purposes) will help evaluate existing hydrofrac measurements of in situ stress. Measurements at a location in the Little Skull Mountain or Striped Hills areas, using a shallow borehole (to be drilled for this purpose) will help evaluate vertical variation in stress near a possible detachment fault that projects toward Yucca Mountain in the subsurface. Locations of the two drillholes will be determined considering the structural and Quaternary tectonic setting of Yucca Mountain.

CONSULTATION DRAFT

The two drillholes, 500 to 800 ft (165 to 260 m) deep, are to be continuously cored. Hydrofrac measurements will use standard procedures. The cores will be sampled at regular intervals, and elastic constants of the samples measured. In addition, the in situ stress in the cored intervals will be evaluated using the three-axis strain recovery technique. These measurements are intended to test the utility of the technique in the Yucca Mountain environment and evaluate whether additional in situ stress measurements are necessary to meet programmatic needs.

If the evaluation is favorable, a program to use these techniques to evaluate in situ stress in the structural blocks adjacent to the site will be planned.

This is an evaluation and planning activity only. Expected duration is six months. Larger scale application of the methods will depend on the results of the evaluation.

Methods and technical procedures

The methods and procedures for Activity 8.3.1.17.4.8.2 are given in the following table.

Method	Technical procedure		Date
	Number	Title	
	(NWM-USGS-)		
Shallow borehole in situ hydrofrac tests	GPP-04, RO	In situ stress investigations	27 June 83
Triaxial strain recovery stress measurement	TBD ^a	TBD	TBD

^aTBD = To be determined.

8.3.1.17.4.8.3 Activity: Evaluate published and unpublished data on paleostress orientation at and proximal to the site and assess the relevance of these data to Quaternary tectonics

Objectives

The objective of this activity is to establish successive orientations of principal horizontal components of stress in the vicinity of Yucca Mountain to evaluate the stability of stress through time and to provide a partial basis for determining the duration of the contemporary tectonic framework.

CONSULTATION DRAFT

Parameters

The parameters of this activity are the orientation and age of paleo-stress indicators.

Description

Statistical summaries of movement directions of conjugate fault sets may be uniquely related to orientation and relative magnitude of principal stresses at the time of faulting. By noting relative ages of different fault sets, a sequential picture of changing stress orientation with time may be developed for a given area. The method has utility where ages of fault sets may be established within narrow limits, as is generally possible for faults cutting the Miocene and younger rocks at Yucca Mountain and vicinity. This activity seeks to relate these faults to the stress regime in which they were formed and to compare that stress regime with the present in situ stress field.

The orientation of fractures and associated slickensides in Miocene or younger rock has been studied in the south-central and southeastern parts of the NTS by Frizzell and Zoback (1987) and by Dockery-Ander, (1984). These data will be merged with data being produced as a byproduct of shaft and mapping activities and the orientation of paleostress deduced using computer analysis.

Surface expressions of fracture displacements will be integrated with similar determinations obtained in subsurface core and exploratory shaft facility evaluations (Activity 8.3.1.4.2.2.4). Duration of this activity is expected to be three to six months.

Methods and technical procedures

The methods and procedures for Activity 8.3.1.17.4.8.3 are given in the following table.

Method	Technical procedure		
	Number	Title	Date
	(NWM-USGS-)		
Evaluation of paleostress indicators	GP-01, RO	Geologic mapping	1 Mar 83
	GP-04, RO	Structural studies	1 Mar 83

CONSULTATION DRAFT

8.3.1.17.4.8.4 Activity: Evaluate theoretical stress distributions associated with potential tectonic settings (wrench fault, normal fault, detachment fault setting, etc.) of the site

Objectives

The objectives of this activity are (1) to evaluate possible three-dimensional orientations of stress trajectories associated with potential tectonic settings of Yucca Mountain, including wrench fault, normal fault, and detachment fault tectonic models; and (2) to evaluate the degree to which in situ stress data from Yucca Mountain and vicinity constrains applicability of these tectonic models to neotectonics of the site.

Parameters

The parameters for this activity are

1. Measured magnitudes of principal stresses.
2. Measured orientation of stress trajectories.

Description

Crustal stress measurements at Yucca Mountain will be compared to theoretical patterns singular to wrench-fault, detachment-fault, and normal-fault tectonic models to help assess the applicability of these models or their various permutations to the site. This activity will evaluate possible theoretical stress patterns associated with these and other tectonic models. The theoretical patterns will be chiefly drawn from published sources (e.g., Berger and Johnson, 1980; 1982; Savage and Smith, 1986) but modified where feasible to parallel potential geologic settings of the site. For example, stress distribution within the upper plate of a detachment fault is somewhat analogous to stress distribution within a glacier or a landslide. Mathematical solutions worked out for the case of landslide by Savage and Smith (1986) will be modified to fit a detachment analogue.

This activity will also evaluate the degree to which the data on stress distribution at Yucca Mountain and vicinity can be rationalized with one or more of the theoretical stress patterns. As part of this evaluation, consideration will be given to the inherent uncertainties in the degree to which the in situ measurements and focal plane solutions represent actual in situ stress at the point of measurement, and the degree to which that point represents some larger volume of rock. Consideration will also be given to potential effects of nontectonic factors, including topography and anisotropic elastic constants. The estimated duration of this activity is six months.

Methods and technical procedures

The methods and technical procedures for Activity 8.3.1.17.4.8.4 are given in the following table.

CONSULTATION DRAFT

Method	Technical procedure		Date
	Number	Title	
Mathematical modeling of stress trajectory modeling three-dimensional stress trajectories	TBD ^a	TBD	TBD

^aTBD = to be determined.

8.3.1.17.4.9 Study: Tectonic geomorphology of the Yucca Mountain region

Objectives

The objectives of this study are (1) to document the magnitude of Quaternary uplift and subsidence within the Yucca Mountain region, and (2) to evaluate regional variation in the nature and intensity of Quaternary faulting.

The major premise of this study is that certain tectonic processes operating during the Quaternary have influenced the development of contemporary geomorphic features; hence, those features record information on the nature, rate, and localization of those processes. Those processes include faulting, uplift, and subsidence. Consideration of regional topography indicates that some areas within the Yucca Mountain region appear to be in the youthful stage of geomorphic development, with deeply incised drainages, V-shaped canyons, and steep mountain fronts. Other areas, in contrast, are characterized by worn-down remnants of old mountains, that are laced with alluviated washes reaching nearly to their summits. This could imply that some areas were, and perhaps still are, actively rising and others subsiding during late Pliocene and Quaternary time.

Planned investigations focus on evaluation of relative rates and location of uplift and subsidence (1) through definition of surfaces of long-lived stability, as gauged by age and degree of development of desert varnish; (2) through identification of subregional variation in range sinuosity and fan development; and (3) through evaluation of the development of the Amargosa drainage system. Variation in the nature and intensity of Quaternary faulting in the area within 100 km of Yucca Mountain will be evaluated through morphometric and morphologic analysis.

The data derived through this study will assist in evaluating the degree to which certain potentially adverse conditions are or are not present at the site and its immediate vicinity, including structural deformation such as uplift, subsidence, folding, or faulting during the Quaternary Period. The data will also be used to assist in formulation and validation of tectonic

CONSULTATION DRAFT

models (Study 8.3.1.17.4.12). Validation includes reconciling structural deformation within the site area with that outside the area, but within 100 km of the site.

The activities of this study are to (1) evaluate age and extent of tectonically stable areas at and near Yucca Mountain, (2) evaluate extent of areas of late Pleistocene and Holocene uplift and subsidence at and near Yucca Mountain, and (3) evaluate variation in the nature and intensity of Quaternary faulting in the area within 100 km of Yucca Mountain through morphometric and morphologic analysis.

8.3.1.17.4.9.1 Activity: Evaluate age and extent of tectonically stable areas at and near Yucca Mountain

Objectives

The objective of this activity is to evaluate the age and areal distribution of surfaces that appear to have been tectonically stable at and near Yucca Mountain through determination of the distribution and age of surfaces with substantial coatings of desert varnish.

Parameters

The parameters for this activity are the age and distribution of desert varnish.

Description

The age and thickness of coatings of desert varnish are a measure of prolonged exposure, which in itself is a measure of stability. The rock-varnish dating technique has recently been applied to dating of Late Cenozoic rocks, surficial deposits, and geologic surfaces in the Yucca Mountain region. Research at Los Alamos National Laboratory has shown that energy dispersive analysis by the scanning electron microscope is a very effective technique to determine the relative abundances of minor elements in rock varnish.

The age of rock varnish has been shown to influence strongly the ratio between soluble and insoluble cations (Dorn, 1983). The rock-varnish dating curve for the Nevada Test Site has been extended to include older deposits and calibrated to several independently dated deposits. Yet to be completed are direct comparisons with the Dorn technique, study of chemical variations in varnish, and variation of cation ratios with varnish depth, and study of significance of varnish color (red versus black) on cation ratio.

The technique will be used to date surficial deposits and materials at Yucca Mountain and vicinity that are not datable by conventional isotopic techniques, including faulted surfaces, alluvial fans, stream terraces, pediment surfaces, bedrock surfaces, and hillslope deposits.

The application planned in this activity uses the cation-ratio dating technique to date "old" surfaces coated with desert varnish. Such surfaces

CONSULTATION DRAFT

are thought to be tectonically more stable than other areas where accumulation of desert varnish is precluded or interrupted because of rapid dissection or alluviation. Desert varnish has been shown to be highly reflective, producing bright spots in Thematic Mapper V satellite imagery. Hence, it is feasible to map such surfaces using the satellite imagery produced as a by-product of another activity (Activity 8.3.1.17.4.3.5).

Calibration of the cation-ratio dating technique (diffused-beam scanning electron microscope procedure) will be achieved by measuring cation ratios of rock varnish at well-dated localities in the NTS region. Cation ratios of samples from within the NTS will be compared with curves showing regional correlation of age with cation ratio. Surfaces with substantial coatings of desert varnish, as shown by maps produced from Thematic Mapper V satellite imagery, will be dated. This activity is estimated to be 10 percent complete. The estimated future duration is two years.

Methods and technical procedures

The methods and procedures for Activity 8.3.1.17.4.9.1 are given in the following table.

Method	Number	Technical procedure	
		Title	Date
Definition and dating of desert-varnish coated surfaces	TBD ^a	Cation-ratio (desert varnish) dating	TBD
	TBD	Analyses of desert varnish coating using remote imagery	TBD

^aTBD = to be determined.

8.3.1.17.4.9.2 Activity: Evaluate extent of areas of Quaternary uplift and subsidence at and near Yucca Mountain

Objectives

The objectives of this activity are to

1. Identify areas of rapid uplift by comparing volume of fan with the area of the associated drainage basin.
2. Identify areas of Quaternary subsidence and uplift, including Amargosa Desert, Crater Flat, Fortymile Wash, Rock Valley, and Ash Meadows, through an analysis of fluvial history of the Amargosa drainage system.

CONSULTATION DRAFT

3. Complete a study of average or general rates of erosion and dissection in the southern Great Basin province.

Parameters

The parameters for this activity are the area of drainage basins, the volume of fans, the drainage pattern, the stream profiles, and the rates of degradation of constructional (volcanic) landforms.

Description

In this activity, areas of Quaternary uplift or subsidence will be defined through identification of basins and ranges within the Yucca Mountain region that show anomalously high rates of erosion or sedimentation, compared with adjoining areas and with province-wide averages. Regional rates of erosion will be documented through completion of a study of degradation and erosion of well-dated Quaternary constructional landforms. Local erosional or depositional anomalies will be determined through comparison of fan volume and drainage basin area, and through analysis of the fluvial history of the Amargosa River and its tributaries.

Alluvial fans and drainage basins will be correlated and delineated on maps. Area of fans and drainage basins in the area will be defined and measured using medium-scale (1:20,000) aerial photographs and topographic maps. Age of material in the fans will be established using Quaternary geologic maps and by field examination, supplemented by dating of fan deposits where required.

The Quaternary history of the Amargosa drainage system will be evaluated. Newly active areas of ponding or incision will be mapped as a means of identifying areas of Quaternary subsidence or uplift. Terraces, shorelines, stream captures, and stream diversions within the Amargosa River drainage basin will be identified, mapped, and interpreted in terms of Quaternary tectonics.

The regional rate of erosion and dissection will be measured through analysis of erosion and degradation of well-dated constructional landforms and volcanic deposits at volcanic centers in the southern Great Basin. This activity is estimated to be 90 percent complete; the remaining work is primarily report publication.

Methods and technical procedures

The methods and procedures for Activity 8.3.1.17.4.9.2 are given in the following table.

CONSULTATION DRAFT

Method	Technical procedure		Date
	Number	Title	
	(NWM-USGS-)		
Mapping, analysis, and correlation of alluvial fans and drainage basins	GP-01, RO ^a	Geologic mapping	1 Mar 83
	GP-03, RO	Stratigraphic studies	1 Mar 83
	GP-17, RO	Describing and sampling soils in the field	19 Jan 86
	GCP-01, RO	Radiometric-age data bank	15 June 81
	GCP-02, R1	Labeling, identification, and control of samples for geochemistry and isotope geology	20 Jan 87
	GCP-03, RO	Uranium-series dating	15 June 81
	GCP-04, RO	Uranium-trend dating	15 June 81
	Needed	Radiocarbon dating	
	Needed	cation-ratio (desert varnish) dating	
Evaluation of Quaternary history of Amargosa drainage system uplift and subsidence	GP-01, RO ^a	Geologic mapping	1 Mar 83
Analysis of regional rate of erosion and dissection	GP-01, RO ^a	Geologic mapping	1 Mar 83
	GP-17, RO	Describing and sampling soils in the field	1 Mar 83

^aRevision No. 1 to GP-01, expected March, 1989, will explicitly address geomorphic mapping.

8.3.1.17.4.9.3 Activity: Evaluate variations in the nature and intensity of Quaternary faulting within 100 km of Yucca Mountain through morphometric and morphologic analysis

Objectives

The objectives of this activity are to

1. Define morphotectonic domains in the area within 100 km of Yucca Mountain and relate them to areal variation in intensity or nature of faulting.

CONSULTATION DRAFT

2. Improve the definition of morphologic indicators of shallow detachment faulting, wrench faulting, and basin-range type normal faulting, and to use those indicators to characterize the nature of faulting in morphotectonic domains within 100 km of Yucca Mountain.
3. Constrain tectonic models applicable to the site through evaluation of regional patterns of Quaternary deformation as expressed by distribution of morphotectonic domains.

Parameters

The parameters for this activity are

1. Structural and stratigraphic indicators, location, and timing of detachment faulting, basin-range faulting, and strike-slip faulting.
2. Regional morphometry of that part of the southwest Basin and Range within 100 km of the site; range spacing relief; total relief; range lengths, widths, and areas; basin lengths, widths, and areas; pediment widths and slopes; range-to-basin width ratios; depths of basin closure range front sinuosity.

Description

The planned activity will be divided into two phases: data gathering and comparative analysis, and interpretation. Data gathering and preliminary analyses will require about one half man-year. Interpretative work will begin late in the first year and progressively expand during succeeding years. Because the activity will provide a useful regional context for geologic and geophysical investigations, it is likely that much of the interpretative work would be carried out in coordination with other investigations (perhaps as a predictive reconnaissance tool). This activity complements Activity 8.3.1.17.4.3.2 (evaluate Quaternary faults within 100 km of Yucca Mountain) and Activity 8.3.1.17.4.6.1 (evaluate Quaternary geology and potential Quaternary faults at Yucca Mountain).

At present, the relationships between geomorphology and tectonic activity are, at best, imperfectly understood. The most successful work to date has involved the use of range front morphometry and morphology to interpret general vertical tectonic activity (Bull and McFadden, 1977; Wallace, 1978; Bull, 1984). These approaches, however, do not clearly resolve differences between the timing and rate of differential vertical movement, and they are of relatively little use in assessing horizontal tectonic activity (e.g., strike-slip faulting, detachment faulting). Moreover, the timing, distribution, and relations between late Cenozoic shallow detachment faulting and basin-range faulting in the Basin and Range are also imperfectly understood. Analysis of the tectonic geomorphology of the area within 100 km of the site, therefore, will require improvement of existing indicators of vertical tectonic activity, identification and definition of new indicators of horizontal tectonic activity (particularly detachment faulting), and at least a general synthesis of what is presently known about the Quaternary tectonics of the region. To evaluate the relation between nature and intensity of Quaternary faulting and morphologic features this activity will:

CONSULTATION DRAFT

1. Compile available Quaternary structural, stratigraphic, and tectonic data for the southwest Basin and Range using existing summaries and reviews.
2. Describe the regional morphometry of the area within 100 km of the site.
3. Develop reconnaissance maps of piedmonts and Quaternary piedmont deposits for the area within 100 km of the site.
4. Develop and refine a suite of geomorphic indicators of shallow detachment faulting, wrench faulting, and normal faulting.
5. Synthesize and relate morphometric and morphologic characteristics to Quaternary tectonic development of the area within 100 km of the site.

This activity is estimated to be 30 percent complete. The expected duration of the remaining work is two years.

Methods and technical procedures

The methods and procedures for Activity 8.3.1.17.4.9.3 are given in the following table.

Method	Technical procedure		Date
	Number	Title	
	(NWM-USGS-)		
Compilation of available Quaternary structural, stratigraphic and tectonic data for the southwest Basin and Range	GP-01, RO ^a	Geologic mapping	1 Mar 83
Description of the regional morphometry of the southwest Basin and Range	GP-01, RO ^a	Geologic mapping	1 Mar 83
Development of reconnaissance maps of piedmonts and Quaternary piedmont deposits for the southwest Basin and Range	GP-01, RO ^a	Geologic mapping	1 Mar 83

CONSULTATION DRAFT

Method	Technical procedure		Date
	Number	Title	
	(NWM-USGS-)		
Development and refinement of a suite of geomorphic indicators of shallow detachment faulting	GP-01, RO ^a	Geologic mapping	1 Mar 83
Synthesis and identification of morphometric and morphologic characteristics related to tectonic activity and history of the region	GP-01, RO ^a	Geologic mapping	1 Mar 83
	GP-03, RO	Stratigraphic studies	1 Mar 83

^aRevision No. 1 to GP-01, expected March, 1989, will explicitly address geomorphic mapping

8.3.1.17.4.10 Study: Geodetic leveling

The primary objective of this study is to evaluate possible historical and contemporary vertical displacements across potentially significant Quaternary faults within 100 km of Yucca Mountain. A secondary objective is to characterize the historical rate of uplift and subsidence in the Yucca Mountain region, and evaluate the possible existence of tectonic boundaries, coinciding perhaps with the Walker Lane or with the Furnace Creek fault zone, that separate domains with differing rates of uplift and subsidence. Geologic evidence suggests that a boundary of such a domain, however diffuse, lies somewhere toward the western edge of the region.

For the purposes of this study, the region is defined as the area bounded by Death Valley on the west, Crystal Springs Valley on the east, Warm Springs on the north, and Las Vegas on the south.

Three activities are planned: (1) releveled of base station network, Yucca Mountain and vicinity; (2) global positioning satellite survey of selected base stations, Yucca Mountain and vicinity; and (3) analysis of existing releveled data, Yucca Mountain and vicinity.

In evaluating the potential effectiveness of these activities, some consideration should be given to uncertainties in the measurements and the ability of the measuring techniques to resolve contemporary deformation. The magnitudes of potential displacements are likely to be proportional to the length of time between surveys. For periods of several years the displacements are likely to be difficult to detect with confidence. For example,

CONSULTATION DRAFT

repeated levelings across the Furnace Creek fault between 1970 and 1985 show no detectable offset, although levelings over this same time period across probable strands of the Death Valley fault indicate possibly 2 mm of vertical displacement across one strand (Artists Drive fault), and possibly 7 mm across another (Sylvester and Bie, 1986). Suitable baselines must be established, however, for possible periodic resurveying during the preclosure time period or for measurement of displacements after large earthquakes, should they occur.

Data developed in this study will be used in Study 8.3.1.17.4.12 (tectonic models and synthesis) to limit estimates of strain rates and contemporary fault displacements within 100 km of Yucca Mountain.

8.3.1.17.4.10.1 Activity: Relevel base-station network, Yucca Mountain and vicinity

Objectives

The objectives of this activity are (1) to evaluate the historic vertical displacement across potentially significant Quaternary faults, and (2) to establish the locations and rates of uplift during historical times through measurement of the change in altitude of benchmarks since the last survey.

Parameters

The parameters for this activity are to determine the altitude of benchmarks.

Description

This activity includes biennial resurvey of existing first-order level lines across Yucca Mountain. The existing lines extend westward from Mercury, Nevada, crossing the Paintbrush Canyon, Bow Ridge, Solitario Canyon, and Windy Wash faults at Yucca Mountain, thence through Crater Flat to the western terminus approximately 25 km west of Amargosa Valley. This line, plus quadrilateral nets across each of the faults listed above, was established in 1982-83.

The desirability of adding two additional surveys is to be evaluated with respect to potential contributions to site characterization and with respect to land access matters. The first of these includes two relatively short lines, one extending from Stovepipe Wells southeast to Death Valley Junction, the other from Death Valley southward along the Amargosa River and thence eastward through Jubilee Pass to Shoshone. This survey provides releveling across the Furnace Creek and southern Death Valley fault zones. The second survey includes the releveling of several earlier first and second-order lines north and east of the NTS, forming a small circuit that immediately surrounds the NTS. The proposed route extends along an older first-order survey from Warm Springs southeastward along Nevada Highway 375 to Crystal Springs, southward along several older second-order lines along U.S. Highway 93 to about 15 km south of Alamo, and southwestward along a dirt road to Corn Creek Springs. This route crosses several Quaternary features

of regional importance, including the northern part of the Death Valley-Pancake Range volcanic belt, the Pahranaagat Range shear zone, and the Las Vegas Valley shear zone, and the Walker Lane belt. Decision to proceed with the two additional surveys is contingent on the results of the evaluation, and review of potential application to Project needs. Baseline surveys are to be completed within one year.

8.3.1.17.4.10.2 Activity: Survey selected base stations, Yucca Mountain and vicinity, using global positioning satellite

Objectives

The objective of this activity is to evaluate contemporary vertical displacement across potentially significant Quaternary faults and the contemporary rate of uplift and subsidence within 100 km of the site on the basis of altitude and position of selected base stations.

Parameters

The parameters for this activity are elevation and location of base stations.

Description

To more fully benefit from the relevelings undertaken as part of Activity 8.3.1.17.4.10.1, junction points and selected benchmarks will be observed periodically (annually and biannually) using the global positioning satellite (GPS). The observations will either be made as part of the National Geodetic Survey GPS program, or alternatively, using recently acquired USGS receivers. GPS vertical measurement precision (replication capability) scales linearly as a function of distance, and is currently on the order of 80 mm over a 50-km line. Comparisons with terrestrial measurements are indirect in the sense that GPS measures a geometrically defined quantity, whereas leveling measures a geopotential difference between points. Accordingly, a gravity dependent correction will be made to bring terrestrial-based height differences into conformity with the GPS-based height differences. Baseline surveys are to be completed within one year.

8.3.1.17.4.10.3 Activity: Analyze existing releveling data, Yucca Mountain and vicinity

Objectives

The objective of this activity is to evaluate historical vertical displacement across potentially significant Quaternary faults, and possible historic uplift and subsidence within 100 km of Yucca Mountain through detection of changes in altitude as recorded by existing leveling data.

Parameters

The parameter for this activity is the altitude of base stations.

Description

This activity will review the results of releveling of the network of benchmarks in the Yucca Mountain region. The activity involves search of archives, and the collection, collation, and analysis of leveling data. No field work is planned. This activity is estimated to be 50 percent complete. The duration of the remaining work is six months.

Methods and technical procedures

The methods and procedures for Study 8.3.1.17.4.10 are given in the following table.

Method	Technical procedure		
	Number	Title	Date
	(NWM-USGS-)		
Resurvey of geodetic leveling network	GP-06, RO	Geodetic, leveling and trilateration surveys	06 June 83
Analysis of rates of uplift during historical times	GP-06, RO	Geodetic, leveling and trilateration surveys	06 June 83

8.3.1.17.4.11 Study: Characterization of regional lateral crustal movement

The objective of this study is to evaluate rates and orientations of historical and current lateral crustal movement based on analysis of existing data on seismicity, historical fault offset, and creep in the Basin and Range province.

Results of the evaluation will be used in Study 8.3.1.17.4.12 (tectonic models and synthesis) to constrain tectonic models applicable to Quaternary tectonics of the site, and in Study 8.3.1.17.4.1 (historical and current seismicity) to constrain probabilistic models of seismicity within 100 km of Yucca Mountain.

The characteristics to be evaluated include historical fault displacements, creep, historical seismicity, focal plane solutions, seismic energy release.

CONSULTATION DRAFT

8.3.1.17.4.11.1 Activity: Analyze lateral component of crustal movement based on historical faulting, seismicity, and trilateration surveys

Objectives

The objective of this activity is to evaluate rates and orientation of historical and current crustal strain in the Basin and Range province and the Yucca Mountain region.

Parameters

The parameters for this activity are historical fault displacements, creep, historical seismicity, focal mechanisms, seismic energy release, historical crustal strain, and changes in distances between benchmarks in the Yucca Mountain region.

Description

Data pertaining to historical seismicity, focal mechanisms, and seismic energy release will be supplied by Study 8.3.1.17.4.1 (historical and current seismicity). Data pertaining to fault displacements, creep, and crustal strain as measured by strain gauges and land surveys will be compiled. Surveys of the trilateration network at Yucca Mountain and vicinity will be repeated.

Methods and technical procedures

The methods and procedures for Activity 8.3.1.17.4.11.1 are given in the following table.

Method	Technical procedure		
	Number	Title	Date
	(NWM-USGS-)		
Synthesis of published information (Basin and Range province)	TBD ^a	Strain rate analysis	TBD
Trilateration surveys (Yucca Mountain region)	GP-06, RO	Geodetic, leveling and trilateration surveys	6 June 83

^aTBD = to be determined.

CONSULTATION DRAFT

8.3.1.17.4.12 Study: Tectonic models and synthesis

The objectives of this study are (1) to synthesize data relevant to tectonics, (2) to develop a model or range of models that establishes the causal relation between application of tectonic forces and formation of structures observed at Yucca Mountain and vicinity, (3) to link observed rates of formation of those structures with regional rates of crustal strain, (4) to forecast changes in tectonic setting and the manner in which those changes will affect both the regional crustal strain rate and tectonic stability in the Yucca Mountain region, (5) to estimate the effect of those changes on rate and nature of crustal strain at Yucca Mountain and vicinity, and (6) to estimate the future rate of tectonic processes at Yucca Mountain.

A tectonic model or range of models will be developed or compiled to satisfy this investigation. Tectonic model is used here to mean a system of postulates, data, and inferences that explains the deformation of the Earth's crust in the vicinity of the site, the forces involved in or producing such deformation, and the resulting geologic structures. Data relevant to faulting, magmatic activity, folding, and uplift and subsidence will be synthesized, including data on gravity residuals, magnetic residuals, seismic velocities, in situ stress, geologic structure and stratigraphy, and tectonic geomorphology.

The compilation or development of regional tectonic models will serve two purposes. The first purpose is to ensure that assumptions that are made about the local manifestation of tectonic processes are consistent with current scientific understanding of tectonic processes acting in the region. For example, the determination of slip rate on the Paintbrush Canyon fault, from age dating of offset strata, will be checked for consistency with interpretive tectonic models that account for the style and rate of faulting throughout the site region. The second purpose of regional tectonic models is to document scientific uncertainty in the characterization of tectonic hazards so that it can be accounted for in evaluations of repository design and performance. This will be accomplished by developing or compiling a range of alternative models that represent the range of current scientific thinking about the tectonic processes that might affect the site.

Regional tectonic models are expected to be most germane to the characterization of the site's ground-motion potential (Investigation 8.3.1.17.3) because earthquake sources at regional distances can contribute to the ground-motion hazard at the site. Alternative tectonic models will be interpreted in terms of alternative, judgmentally weighted seismic source zones in a probabilistic seismic hazard analysis of the site (Study 8.3.1.17.3.6). In addition, tectonic models will provide context for interpretations of the local, preclosure surface faulting potential (Investigation 8.3.1.17.2) and the potential for faulting, folding, uplift, or subsidence to affect postclosure repository performance (Investigation 8.3.1.8.2).

The activities planned for this study are to (1) evaluate tectonic processes and tectonic stability at the site, (2) evaluate tectonic models, and (3) evaluate tectonic disruption sequences.

CONSULTATION DRAFT

8.3.1.17.4.12.1 Activity: Evaluate tectonic processes and tectonic stability at the site

Objectives

The objectives of this activity are to

1. Synthesize gravity studies at Yucca Mountain and vicinity, and define regional variations in mass, and attribute them, as appropriate, to variations in crustal thickness, degree of melting, shallow intrusions, distribution of specific stratigraphic units, and faults.
2. Synthesize magnetic studies at Yucca Mountain and vicinity, and define areal variations in magnetic field, and relate them as appropriate to distribution of specific stratigraphic units, shallow intrusions, and subsurface configuration of faults.
3. Evaluate the regional extent of detachment faults, wrench faults, volcanic rocks belonging to the Death Valley-Pancake Range belt, evaluate the regional pattern of oroclinal bending (oroflexing), evaluate the regional extent of Miocene ash-flow tuffs and associated pyroclastic and epiclastic rocks, and evaluate regional extent of Paleozoic rocks known to be aquifers, aquitards, or to provide favored surfaces of detachment or thrusting.
4. Synthesize and evaluate information pertaining to Quaternary wrench faulting in the Walker Lane (Las Vegas to Cedar Mountain) and constrain, if possible, the rate of offset and recurrence interval of Cedar Mountain type events, and the applicability of this information to geologic hazards at the site.
5. Synthesize and evaluate information pertaining to detachment faults at Yucca Mountain and vicinity, and constrain, if possible, the rate of displacement, subsurface configuration, and character of risk posed by this class of faults.
6. Synthesize and evaluate information pertaining to normal (and north-trending oblique and strike-slip faults) at the site and vicinity, and constrain, if possible, aggregate strain rate, subsurface configuration, recurrence interval, and character of risk posed by this class of faults.
7. Synthesize and evaluate information pertaining to the northeast-trending left-lateral strike-slip faults at the NTS and vicinity, and constrain, if possible, slip rate, recurrence interval, and character of risk posed by this class of fault.

Parameters

The parameters for this activity are gravitational force, geomagnetic field, geologic structure, and stratigraphy.

Description

This activity includes compilation and interpretation of geologic, gravity, and magnetic maps of the Beatty 1:100,000 quadrangle, synthesis of geologic and geophysical studies, and preparation of topical reports on Quaternary wrench faulting, detachment faulting, normal faulting, and left-lateral strike-slip faulting. Information and interpretations supplied by these syntheses will form the basis for formulation of a tectonic model or models describing the way in which forces and bodies in the Yucca Mountain region interact to produce the geologic and tectonic framework of the proposed repository.

Maps (1:100,000 scale) of Bouguer gravity, residual gravity, and isostatic gravity will be compiled and amplified where necessary with additional gravity surveys. Data on density of geologic units will be collected and compiled. Filtered gravity maps (nominal passing wavelengths of 240 km) will be produced. Maxi spot or a comparable computer program will be used to identify and quantify gradient changes. Crustal models based on gravity and seismic velocity will be produced.

Maps (1:100,000 scale) of aeromagnetic data of the NTS and vicinity will be compiled. Source models combining gravity data with magnetic signature of relevant anomalies will be calculated and compared.

Geologic maps (1:100,000 scale) of the Beatty 1 by 1/2° quadrangle will be compiled from published sources. Geologic cross sections showing inferred subsurface structural and stratigraphic geometry will be prepared. This activity is estimated to be 50 percent complete. The duration of the future work is estimated to be four years.

Methods and technical procedures

The methods and procedures for Activity 8.3.1.17.4.12.1 are given in the following table.

Method	Technical procedure		
	Number	Title	Date
	(NWM-USGS-)		
Regional gravity synthesis	GPP-01, RO	Gravity measurement and data reduction	14 Jan 85
Regional magnetic synthesis	GP-01, RO TBD	Geologic mapping Magnetic measurements and data interpretation	1 Mar 83 TBD
Beatty 1:100,000 geologic synthesis	GP-01, RO	Geologic mapping	1 Mar 83
	GP-03, RO	Stratigraphic studies	1 Mar 83
	GP-04, RO	Structural studies	1 Mar 83

Method	Technical procedure		Date
	Number	Title	
(NWM-USGS-)			
Synthesis - Quaternary wrench faulting in Walker Lane	GP-01, RO	Geologic mapping	1 Mar 83
	GP-04, RO	Structural studies	1 Mar 83
Synthesis - Detachment faults at NTS and vicinity	GP-01, RO	Geologic mapping	1 Mar 83
	GP-04, RO	Structural studies	1 Mar 83
Synthesis - Quaternary faulting at NTS and vicinity	GP-01, RO	Geologic mapping	1 Mar 83
	GP-04, RO	Structural studies	1 Mar 83
Synthesis - Left-lateral strike-slip faults	GP-01, RO	Geologic mapping	1 Mar 83
	GP-04, RO	Structural studies	1 Mar 83

^aTBD = To be determined.

8.3.1.17.4.12.2 Activity: Evaluate tectonic models

Objectives

The objectives of this activity are to

1. Formulate a range of tectonic models that relate the nature and estimated rates (including bounding values of those estimated rates) of Quaternary processes (volcanism, faulting, uplift and subsidence, lateral strain, and possibly folding) of potential significance to design and performance of the repository at Yucca Mountain.
2. Ensure that assumptions, inferences, and conclusions concerning tectonic processes that are important to design and performance of the repository are consistent with tectonic models applicable to the site.
3. Ensure that uncertainty in the data, assumptions, and inferences concerning rates and nature of those tectonic processes that are important to design or performance of the repository is adequately reflected in conclusions about those processes.

Parameters

The parameters for this activity are recurrence rates, strain rates, ambient stress, boundary conditions, structural geology of the site area,

CONSULTATION DRAFT

structural geology of the area within 100 km of Yucca Mountain, location and geometry of Quaternary faults.

Description

The various tectonic hypotheses that are potentially applicable to the neotectonics of Yucca Mountain include as end members the following: (1) the wrench fault hypothesis, which explains deformation at Yucca Mountain as resulting from right-lateral transform movement on an intracontinental shear zone (the Walker Lane) passing through or near the site area; (2) the detachment fault hypothesis, which explains deformation at Yucca Mountain as resulting from extension on subsurface detachment faults and the set of listric normal faults which merge with the detachment faults; and (3) the basin-range normal fault hypothesis, which explains the Quaternary normal faults at Yucca Mountain as planar rotational faults extending to great depth. Quaternary volcanism in and south of Crater Flat could be attributed to (1) volcanism along a north-northeast-trending incipient rift zone (Death Valley-Pancake Range zone) or (2) volcanism at zones of extension developed between en echelon segments of northwest-trending wrench faults (leaky transform hypothesis). Each of these hypotheses, as stated, is consistent with some data and inconsistent with other data. There probably are, however, a set of models that include various elements of these hypotheses and that satisfactorily explain all or most of the data.

In this activity, tectonic models will be formulated, and the degree to which those models qualitatively and quantitatively incorporate and reconcile information on the parameters just listed will be evaluated. That information includes that gathered by other studies in tectonics and site geology. The tectonic models are expected to evolve as additional data are gathered, and hence this activity is expected to continue for the duration of the site characterization process. Preliminary models will be produced for use during site characterization.

Methods and technical procedures

The methods and procedures for Activity 8.3.1.17.4.12.2 are given in the following table.

Method	Technical procedure		Date
	Number	Title	
Tectonic model evaluation	TBD ^a	TBD	TBD

^aTBD = to be determined.

8.3.1.17.4.12.3 Activity: Evaluate tectonic disruption sequences

Objectives

The objective of this activity is to evaluate disruption sequences involving faulting, folding, uplift and subsidence, and volcanism that are of potential significance to design or performance of the repository.

Parameters

The parameters for this activity are tectonic models, processes, and rates; probabilities of tectonic events; and physical consequences at the proposed repository site.

Description

The purpose of this activity is to evaluate disruption sequences involving faulting, folding, uplift and subsidence, and volcanism, acting either individually or in concert. Where possible, the probability of each sequence actually occurring in the future will be estimated and the range of geologic consequences described.

Methods and technical procedures

The methods and procedures for Activity 8.3.1.17.4.12.3 are given in the following table.

Method	Technical procedure		Date
	Number	Title	
Tectonic process scenario analysis, Nevada Test Site, and vicinity	TBD ^a	Synthesis	TBD

^aTBD = to be determined.

8.3.1.17.4.13 Application of results

The information derived from the studies and activities of the plans described previously will be used in the following issues, information needs, and investigations of site characterization, repository design, and performance assessment:

CONSULTATION DRAFT

<u>Number</u>	<u>Subject</u>
1.1.1	Site information needed to calculate the releases of radionuclides to the accessible environment (Section 8.3.5.13.1)
1.1.3	Representative release scenarios that address both anticipated and unanticipated conditions (Section 8.3.5.13.3)
1.5.1	Site information and design concepts needed to calculate the release rates from the engineered barrier system (Section 8.3.5.10.1)
1.6.1	Site information and design concepts needed to identify the fastest path of likely radionuclide travel and to calculate the ground-water travel time along that path (Section 8.3.5.12.1)
1.8	NRC siting criteria Site information needed to identify favorable and potentially adverse conditions at the site that may influence postclosure repository performance (Section 8.3.5.17)
1.11.1	Site characteristics needed for design (Section 8.3.2.2.1)
8.3.1.2.1	Regional hydrologic system
8.3.1.4.2	Geologic framework
8.3.1.4.3	Three-dimensional rock characteristics model
8.3.1.6.3	Tectonic effects on erosion
8.3.1.8.1	Volcanic activity
8.3.1.8.2	Information required on rupture of waste packages due to tectonic events
8.3.1.8.3	Information required on changes in saturated and unsaturated zone hydrology due to tectonic events
8.3.1.8.4	Information required on changes in rock geochemical properties resulting from tectonic processes
4.4.1	Site and performance information needed for design (Section 8.3.2.5.1)
4.4.7	Potential impacts of tectonic activity on design (Section 8.3.2.5.7)
8.3.1.15.1	Stratigraphy and structure necessary to locate the underground facility

CONSULTATION DRAFT

- 8.3.1.15.3 Spatial distribution of ambient stress and thermal conditions
- 8.3.1.17.1 Potential volcanic activity that could have an impact at the site
- 8.3.1.17.2 Potential fault movements at the site
- 8.3.1.17.3 Ground motion at the site from potential man-made or natural seismic events

8.3.1.17.4.14 Schedule and milestones

This investigation (8.3.1.17.4), addressing preclosure tectonics data collection and analysis, contains twelve studies: 8.3.1.17.4.1 (historical and current seismicity), 8.3.1.17.4.2 (location and recency of faulting potential near prospective facilities), 8.3.1.17.4.3 (Quaternary faulting within 100 km of Yucca Mountain, including the Walker Lane), 8.3.1.17.4.4 (Quaternary faulting proximal to the site within northeast-trending fault zones), 8.3.1.17.4.5 (detachment faults at or proximal to Yucca Mountain), 8.3.1.17.4.6 (Quaternary faulting within the site area), 8.3.1.17.4.7 (subsurface geometry and concealed extensions of Quaternary faults at Yucca Mountain), 8.3.1.17.4.8 (stress field within and proximal to the site area), 8.3.1.17.4.9 (tectonic geomorphology of the Yucca Mountain region), 8.3.1.17.4.10 (geodetic leveling) 8.3.1.17.4.11 (characterization of regional lateral crustal movement), and 8.3.1.17.4.12 (tectonic models and synthesis). In the figure that follows, the schedule information for these studies is presented in the form of timelines. The timelines extend from implementation of the approved study plans to the issuance of the final products associated with the studies. Summary schedule and milestone information for this investigation can be found in Section 8.5.1.1.

Three of the studies in this investigation (8.3.1.17.4.1, 8.3.1.17.4.6, and 8.3.1.17.4.10) are ongoing. Studies 8.3.1.17.4.2 through 8.3.1.17.4.5, 8.3.1.17.4.7 through 8.3.1.17.4.9, and 8.3.1.17.4.11 are expected to begin within the first year of site characterization.

The studies of this entire investigation are planned to progress in parallel with performance and design activities in an iterative fashion. The results of these studies will be used to resolve Issues 1.1 (total system performance), 1.8 (NRC siting criteria), 1.10 (waste package performance and design), and 1.11 (repository performance and design), and to support advanced conceptual and license application designs. This information will also be used in resolution of Issue 4.2 (Section 8.3.2.4) related to preclosure radiological safety.

The studies in this investigation are not seriously constrained by other program elements. Within this investigation, several studies depend upon each other. Figures 8.3.1.17-4 and 8.3.1.17-5 show linkages between preclosure tectonics data collection and analysis studies and preclosure vibratory ground motion and faulting assessment studies.

CONSULTATION DRAFT

The study numbers and titles corresponding to the timelines are shown on the left of the following figure. The points shown on the timelines represent major events or important milestones associated with the study. Solid lines represent study durations, and dashed lines show interfaces. The data input and output at the interfaces are shown by circles.

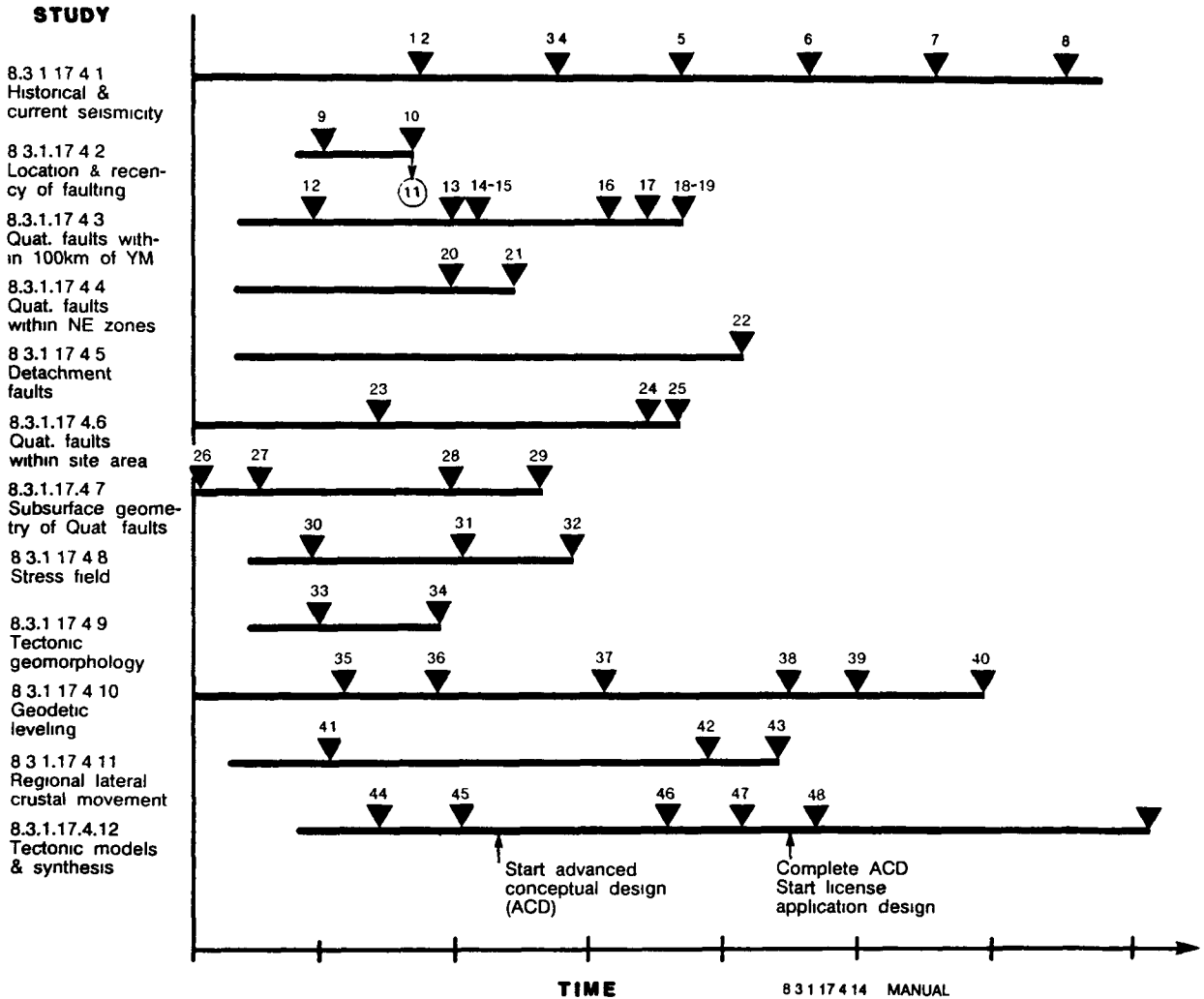

CONSULTATION DRAFT

The points on the timeline and the data input and output at the interfaces are described in the following table:

<u>Point number</u>	<u>Description</u>
1	Milestone Z308. Complete compilation of historical earthquake record.
2	Milestone Z309. Issue current annual seismicity data.
3	Milestone Z310. Issue current annual seismicity data.
4	Milestone Z315. Issue report on the evaluation of potential for induced seismicity at and near the site.
5	Milestone Z311. Issue current annual seismicity data.
6	Milestone Z312. Issue current annual seismicity data.
7	Milestone Z313. Issue current annual seismicity data.
8	Milestone Z314. Issue current annual seismicity data.
9	Complete plans for trenching in Midway Valley and initiate trenching.
10	Report available on exploratory trenching in Midway Valley.
11	Results of exploratory trenching at Midway Valley are available to Activity 8.3.1.17.2.1.1 to assess the potential for surface faulting at locations of surface facilities important to safety.
12	Milestone R845. Recommendation on whether to proceed with regional deep seismic survey.
13	Milestone Z320. Issue report on the evaluation of the Cedar Mountain earthquake of 1932 and its bearing on wrench tectonics of the Walker Lane within 100 km of the site.
14	Milestone Z321. Issue report on the evaluation of the Bare Mountain fault.
15	Milestones P797 and P798. Issue reports on seismic refraction and reflection feasibility studies.
16	Milestone Z322. Issue report on the evaluation of structural domains and the characterization of the Yucca Mountain area with respect to regional patterns of faults and fractures.

CONSULTATION DRAFT

<u>Point number</u>	<u>Description</u>
17	Milestone Z318. Issue report on the evaluation of crustal structure and subsurface expression of Quaternary faults in an east west transect crossing Furnace Creek, Yucca Mountain, and Walker Lane.
18	Milestone P724. Issue report on hydrothermal alteration, NTS and vicinity, from Thematic Mapper-V.
19	Milestone P880. Issue report on the evaluation of Quaternary faulting within 100 km of yucca Mountain.
20	Milestone Z323. Issue report on the evaluation of the Rock Valley fault system.
21	Milestones Z324 and Z325. Issue reports on the evaluations of the Mine Mountain fault system and the Stagecoach Road and Cone Springs fault zones.
22	Milestone P879. Issue summary report on detachment faults at or proximal to Yucca Mountain.
23	Issue preliminary report on the age and recurrence of movement of Quaternary faults at Yucca Mountain.
24	Milestone Z238. Issue final report on the age and recurrence of movement of Quaternary faults at Yucca Mountain.
25	Milestone P880. Issue report on Quaternary geology and faults of Yucca Mountain.
26	Milestone Z319. Complete evaluation of intermediate depth (to 2-3 km) seismic reflection and refraction methods and plan potential applications of these methods within the site area.
27	Milestone Z335. Evaluate shallow seismic reflection (mini-sosie) methods and, if appropriate, conduct surveys at selected structures at and proximal to the site area.
28	Milestones Z239 and Z330. Complete detailed aeromagnetic and gravity surveys of the site area.
29	Milestone Z331. Complete detailed ground magnetic survey of specific features within the site area.
30	Milestone Z337. Evaluate and test shallow borehole hydrofrac and triaxial strain recovery methods for the determination on in situ stress and, if appropriate, plan potential applications.

CONSULTATION DRAFT

<u>Point number</u>	<u>Description</u>
31	Milestone Z338. Issue report on the evaluation of published and unpublished data on paleostress orientation at and proximal to the site and assessment of the relevance of these data to future stress orientation.
32	Milestone Z336. Issue report on the present stress field within the site area.
33	Milestone Z342. Issue report on the variations in the nature and intensity of Quaternary faulting within 100 km of Yucca Mountain through morphometric and morphologic analysis.
34	Milestone Z341. Issue report on the extent of areas of Quaternary uplift and subsidence at and near Yucca Mountain.
35	Milestone Z343. Complete annual re-leveling of base-station network, Yucca Mountain and vicinity.
36	Milestone Z348. Issue report on the analysis of geodetic leveling data, Yucca Mountain and vicinity.
37	Milestone Z344. Complete annual re-leveling of base-station network, Yucca Mountain and vicinity.
38	Milestone Z347. Issue report on GPS survey of selected base-stations, Yucca Mountain and vicinity.
39	Milestone Z345. Complete annual re-leveling of base-station network, Yucca Mountain and vicinity.
40	Milestone Z346. Complete annual re-leveling of base-station network, Yucca Mountain and vicinity.
41	Complete annual re-survey of trilateration network, Yucca Mountain and vicinity.
42	Complete re-survey of trilateration network, Yucca Mountain and vicinity.
43	Issue report on historical and current lateral crustal movement in the Yucca Mountain region.
44	Milestone P701. Complete preliminary regional tectonic model.
45	Milestone P762. Issue report on tectonic scenarios.
46	Milestone Z351. Issue report on the evaluation of tectonic models.
47	Milestones P740 and P741. Issue magnetic and gravity maps and interpretations of Beatty, 1:100,000 quadrangle.

CONSULTATION DRAFT

Point
number

Description

- | | |
|----|--|
| 48 | Milestone Z350. Issue report on the evaluation of tectonic processes and tectonic stability at the site. |
| 49 | Milestone M383. Issue report on final tectonic model. |