

RECEIVED

SEP 23 1996

OSTI

LS-124 (ANL)
Y. Jin, G. Nicholls
September 1988

COMPUTATIONS PREDICTING RF CAVITY CHARACTERISTICS

The APS storage ring cavity is a single cell semi-spherical structure patterned along the lines of the KEK Photon Factory and the Daresbury cavities. The cavity was initially scaled to the APS frequency of 352.9 MHz using the computer code URMEL.* Before construction of the prototype, it was considered essential to simulate the cavity as it would be measured in the machine shop as it was being built. The cavity has four large ports on the equator which would lower the frequency, but by how much? The code URMEL is only able to represent structures with rotational symmetry; MAFIA is three dimensional, and thus is able to simulate the actual structure.

The first task was to determine what mesh size would be required using MAFIA** to represent the structure in detail equivalent to that using URMEL. It was found that a mesh of 40,000 for one eighth or 80,000 for one fourth structure (it is not homogeneous mesh) and finer gave a result which agreed with the frequency predicted by URMEL (MESH 5000); thus, the above mesh points are used for the following calculations.

The computations not only give the effects of the ports on the frequency, but also a simulated tuner has been inserted into a port at various depths; thus, we have a prediction of a tuning curve. For each of the conditions, the first ten modes have been calculated, so we can see the effect of the tuner on the fundamental mode and also on the Higher Order Modes (HOM).

The basic shape and dimensions of the cavity are shown in Fig. 1a. There are two 14-cm ports around the axis of symmetry. They provide the openings for beam passage (along the beam orbit). The basic shape has rotational symmetry; thus, the 2-D code URMEL can be used to calculate the parameters of the cavity.

*URMEL 2-D code from DESY, Notkestrasse 85, D2000, Hamburg 52, FRG.

**MAFIA 3-D code from DESY, Notkestrasse 85, D2000, Hamburg 52, FRG.

DISTRIBUTION OF THIS DOCUMENT IS UNLIMITED

MASTER

REVISION

The actual shape of the prototype is shown in Fig. 1b. This shape has ports of different sizes on the equator. The ports are for the power input coupler, the tuner, and possible HOM suppressor techniques. For faster vacuum pumping during initial processing, a vacuum pump may also be attached. This actual shape does not have rotational symmetry, so the 3-D code MAFIA is used to compute the parameters, including the effect of a tuner.

I. Frequencies, Q values, and shunt impedance calculation.

For a cavity with 7-cm radius beam ports, the cutoff frequency of the ports is 1.6 GHz. Higher order modes below this frequency are 'trapped' within the cavity and can build up considerable stored energy and field. Table 1 lists the result of computing the part modes up to the 'cutoff' frequency using one-fourth structure of the cavity under the boundary conditions ($x_1, x_n, y_1, y_n, z_1, z_n = 2 \ 1 \ 1 \ 1 \ 1 \ 1$). There are 30 modes: Listed is the mode number, frequency, Q, shunt impedance, and R/Q. Some higher modes have rather high shunt impedance, in particular modes 3, 8, 24, and 28. It will be necessary to analyze the field configuration of these modes and design special antenna to suppress them. Here we should point out that if one needs to get the complete modes of the cavity, it would be necessary to run MAFIA another three times under three other boundary conditions. Each run with different boundary conditions will require a CPU time of about 6-7 hours on the VAX-8700.

Comparing the results from MAFIA with that from URMEL, the frequencies and Q values of several of the lowest modes agree with each other very well; however, the two codes do not always predict the same shunt impedance (R_s) (see Table 2).

II. Frequency shift due to holes on the equator.

When the cavity system is fully assembled with power input coupler (which LEP states has a neutral tuning effect), tuner, and fixed tuner (which KEK uses to stagger HOM frequencies), the cavity will have a frequency close to that in Table 1. However, as the cavity is being machined it will look like Fig. 1b. It will have four rather large, empty ports. We need to know the effect on the resonant frequency of the ports so that we will know when to stop machining. Machining at the equator lowers the frequency; the empty ports also lower the frequency.

DISCLAIMER

**Portions of this document may be illegible
in electronic image products. Images are
produced from the best available original
document.**

DISCLAIMER

This report was prepared as an account of work sponsored by an agency of the United States Government. Neither the United States Government nor any agency thereof, nor any of their employees, makes any warranty, express or implied, or assumes any legal liability or responsibility for the accuracy, completeness, or usefulness of any information, apparatus, product, or process disclosed, or represents that its use would not infringe privately owned rights. Reference herein to any specific commercial product, process, or service by trade name, trademark, manufacturer, or otherwise does not necessarily constitute or imply its endorsement, recommendation, or favoring by the United States Government or any agency thereof. The views and opinions of authors expressed herein do not necessarily state or reflect those of the United States Government or any agency thereof.

Table 1
Possible Modes up to Cut-off Frequency

Mode	Frequency (MHz)	Q	R_s (Ω)	R_s/Q (Ω)
1	352.835	4.866×10^4	9.04×10^6	185.8
2	587.018	7.503×10^4	3.02×10^{-5}	4.0×10^{-10}
3	739.653	4.265×10^4	1.03×10^6	24.2
4	774.166	8.084×10^4	2.04×10^{-4}	2.5×10^{-9}
5	803.801	5.232×10^4	2.60×10^{-4}	5×10^{-9}
*6	916.185	-	-	-
7	917.600	8.158×10^4	8.6	1.05×10^{-4}
8	922.302	1.022×10^5	5.78×10^6	56.6
9	933.065	8.604×10^4	8.09×10^{-3}	9.4×10^{-8}
10	958.435	6.822×10^4	3.11×10^{-4}	4.6×10^{-9}
*11	1002.383	-	-	-
12	1061.290	1.259×10^5	3.75×10^{-2}	2.98×10^{-7}
13	1084.749	8.775×10^4	22.4	2.55×10^{-4}
14	1114.575	1.355×10^5	1.9×10^{-2}	1.4×10^{-7}
*15	1125.193	-	-	-
16	1145.480	1.001×10^5	2.49	2.49×10^{-5}
17	1159.892	7.546×10^4	671	8.89×10^{-3}
*18	1186.310	-	-	-
*19	1197.357	-	-	-
20	1213.602	1.455×10^5	466	3.2×10^{-3}
21	1234.322	9.414×10^4	366	3.89×10^{-3}
*22	1277.038	-	-	-
*23	1292.900	-	-	-
24	1311.558	6.988×10^4	9.2×10^4	1.32
*25	1333.949	-	-	-
*26	1385.398	-	-	-
*27	1442.750	-	-	-
28	1499.674	8.259×10^4	2.06×10^6	24.9
*29	1531.964	-	-	-
*30	1635.127	-	-	-

*Not a good solution, but the frequency may be okay.

Table 2
Comparison of MAFIA and URMEL

MAFIA (1/4 Structure, 80,000 Mesh)			URMEL (Mesh 5000)		
Frequency (MHz)	Q	R_s ($M\Omega$)	Frequency (MHz)	Q	R_s ($M\Omega$)
352.835	48,660	9.04	353.0	48,600	11.23
739.653	42,650	1.03	742.0	41,630	0.03
922.302	102,200	5.78	924.6	108,800	1.25

Prior to designing the cavity, the effects of the port size on frequency were studied. We first put a right cylindrical hole on the cavity wall, with the axis of the hole perpendicular to the axis of the cavity. Because this model contains symmetry, only one eighth of the structure is needed in computing the frequency shift which would result from different hole sizes. The one eighth structure (as reconstructed by MAFIA) is shown in Fig. 2. This model was run for various hole sizes. The curve of fundamental mode frequency shift resulting from different hole sizes is shown in Fig. 3. In this computation the depth of the port was kept constant at 10 cm. From this curve we see that each 7-cm radius hole would lower the frequency by 1/2 MHz and each 6-cm hole would lower the frequency by 1/4 MHz. With this result, we had confidence in designing the prototype cavity with two 6-cm radius and two 7-cm radius ports. Later we will present the results of a computation representing all four ports.

III. Effect of tuner insertion into the cavity.

There must be a tuner in the cavity to compensate for thermal and beam loading effects. When the air (dielectric constant 1.0006) is removed, the change in the dielectric constant causes the frequency to rise. But the structure is not mechanically rigid, and as the air is removed the gap edges move together, lowering the frequency. When developing its required voltage, the cavity will be dissipating close to 100 kW. With this dissipation, parts of the internal surface of the cavity will expand and distort. The net result of these effects and beam loading effects must be compensated for by the tuner.

The effect of a 12-cm diameter tuner has been computed using one-fourth structure of the cavity, which is shown in Fig. 4. A travel of six 1/2 cm into the cavity will give a tuning range of 1.5 MHz (Fig. 5). This is thought to be adequate. Presented in Table 3 is the variation in frequency of some of the HOMs for different tuner positions. In the complete assembly, we will attempt to not have HOM frequencies coincident with multiples of the rotational frequencies.

Table 3
Effect of 6-cm Radius Tuner

Mode	Frequency(MHz)				
	Tuner Position				
	h=-6.35 cm	h=-3.05 cm	h=-1.05	h=0	h=5 cm
1	354.390	353.505	353.002	352.834	352.627
2	592.565	589.842	587.778	587.017	585.962
3	743.693	741.915	740.332	739.650	738.496
4	781.854	778.906	775.507	774.165	772.098
5	810.478	806.222	804.371	803.792	802.959
6	913.492	916.410	916.210	916.182	917.040
7	917.687	922.186	922.357	922.306	922.133
8	922.190	938.876	950.251	941.249	930.123
9	959.727	996.134	977.849	995.880	957.031
10	1016.71	1026.46	1010.28	1076.60	1002.61

IV. Computation of the prototype.

The prototype of the storage-ring rf cavity is being manufactured. It has four right circular cylindrical holes (ports), two of them are 12 cm in diameter (into one will be inserted the tuner) and two 14.4 cm in diameter (into one will be inserted the power input coupler.) Because the axes of the ports are perpendicular to each other, we need only use one eighth of the structure in the computation. The prototype cavity hole sizes are shown in Fig. 1b. The MAFIA interpretation of the input data is shown in Fig. 6.

The calculated results are shown in Table 4. MAFIA predicts that the prototype cavity (with empty ports) will have a fundamental resonant frequency 1.4 MHz lower than would be the case without ports (as calculated by URMEL). It appears that if the prototype measures to be 351.5 MHz with empty ports, it can be made to operate at 352.9 MHz when it is a complete assembly. The second 14-cm port will be fitted with a second power coupler

test stand. This second coupler will allow "loading" the cavity to stress the input power coupler, as it will be with varying beam-loading conditions.

V. Proposed Continuing Studies.

Additional analysis of the cavity can start from a simple cylindrical shape, as has been done in the companion paper "Mode Selection and Boundary Conditions." When the prototype cavity is available, all modes up to the beam pipe cutoff frequency will be explored using perturbation techniques by "bead pulling." This will be done using various shapes of perturbing objects.

Table 4
Expected Modes to be Found in Prototype (with Ports)

Mode	Frequency (MHz)	Q	R_s (Ω)	R_s/Q (Ω)
1	351.507	4.894×10^4	9.06×10^6	185.1
2	732.406	4.291×10^4	1.07×10^6	24.9
3	760.989	7.835×10^4	1.42×10^4	0.18
*4	916.848	-	-	-
5	917.418	8.143×10^4	1.08×10^4	0.13
6	921.751	1.013×10^5	4.36×10^6	43.0
7	1056.51	7.287×10^4	3.28×10^4	0.45
8	1127.80	6.569×10^4	1.6×10^4	0.24
9	1145.40	4.633×10^4	1.3×10^5	2.8
*10	1211.59	-	-	-

*Not a good solution, but the frequency may be okay.

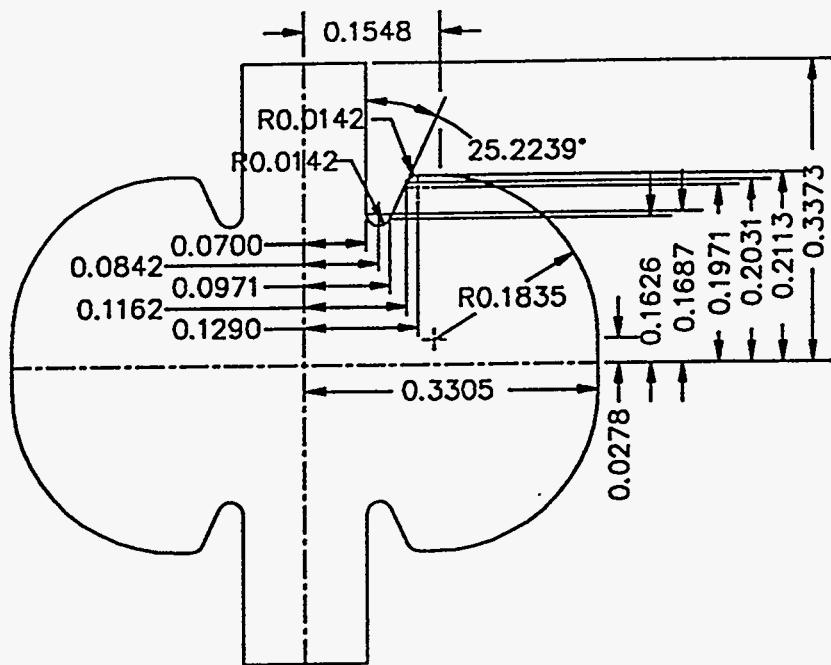
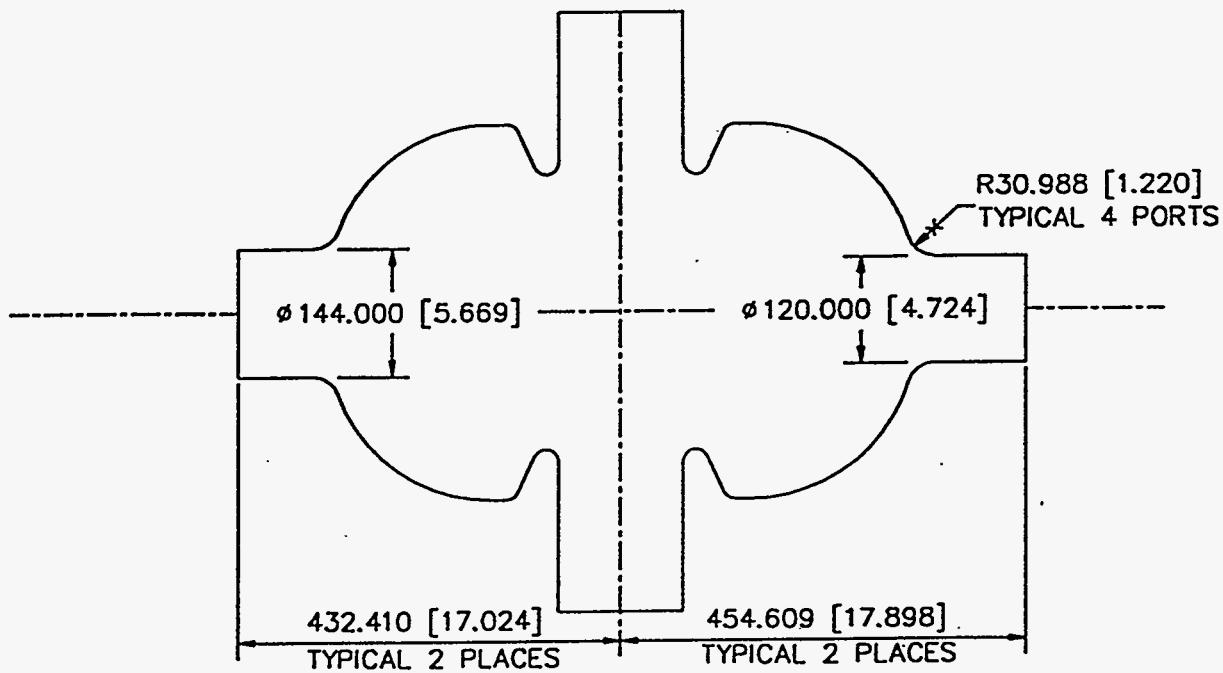

Fig. 1a. The basic shape and dimensions of the cavity.



DIMENSIONS: MILLIMETERS [INCHES]

Fig. 1b. The actual shape of the prototype with ports.

RF CAVITY

MAPLA

CONTENT:
 MATERIALS:
 0
 ELEMENTS:
 X-RANGE:
 0.0000E+00
 0.8800
 Y-RANGE:
 0.0000E+00
 0.4800
 Z-RANGE:
 0.0000E+00
 0.8375
 VIEWPOINT:
 -0.4055
 0.2150
 1.103
 PROJ. 0.00

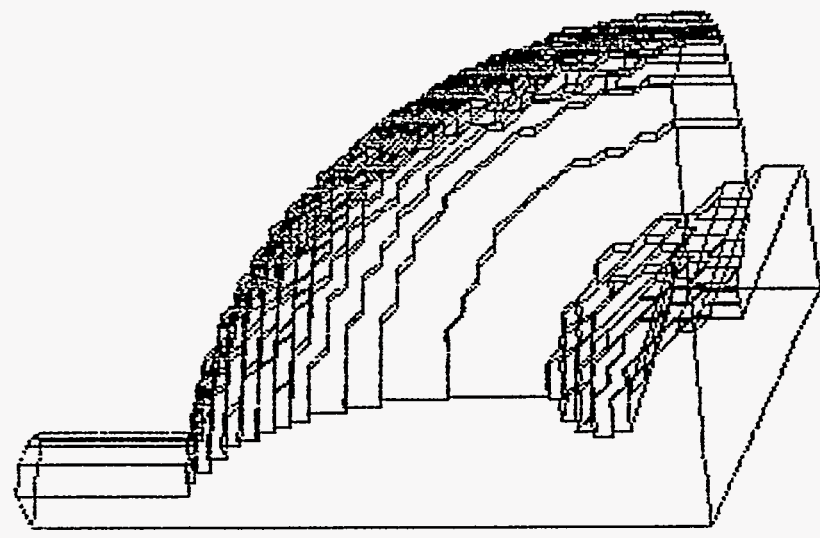
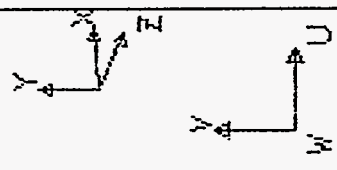

Fig. 2. One-eighth structure of the cavity with hole.

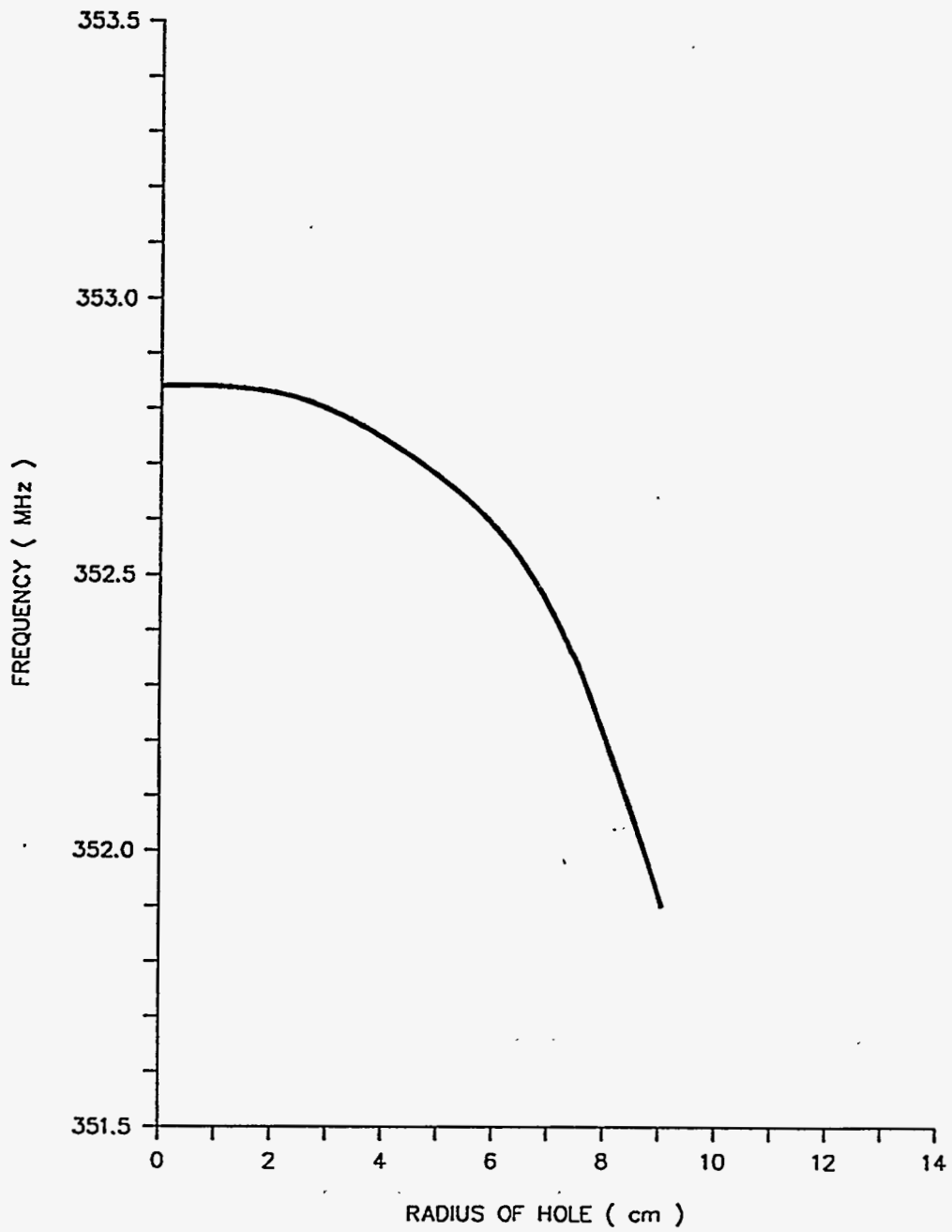

Fig. 3. The fundamental mode frequency shift for varying hole size.

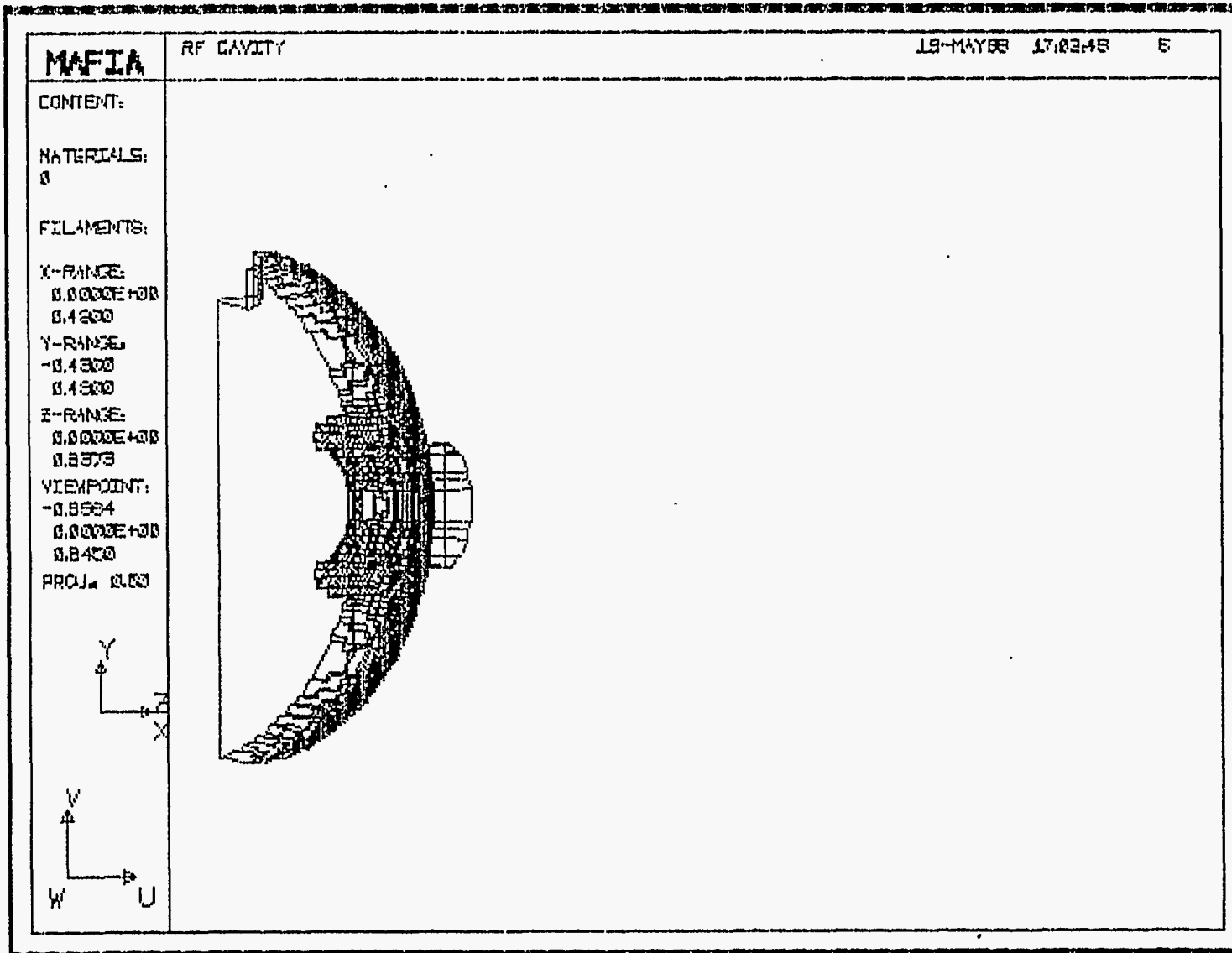

Fig. 4. One-fourth structure of the cavity, used for calculating tuner range.

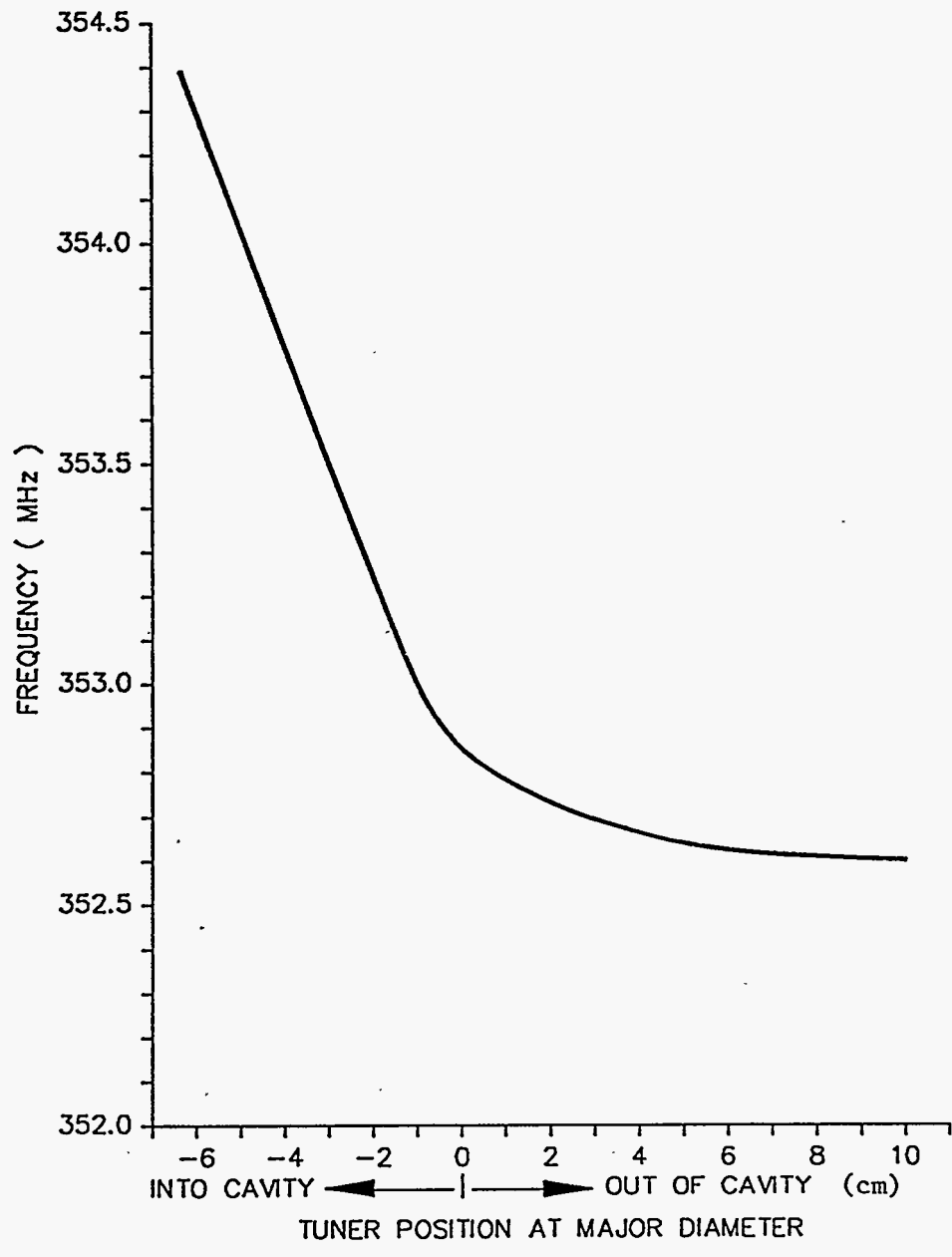

Fig. 5. Effect of tuner. .

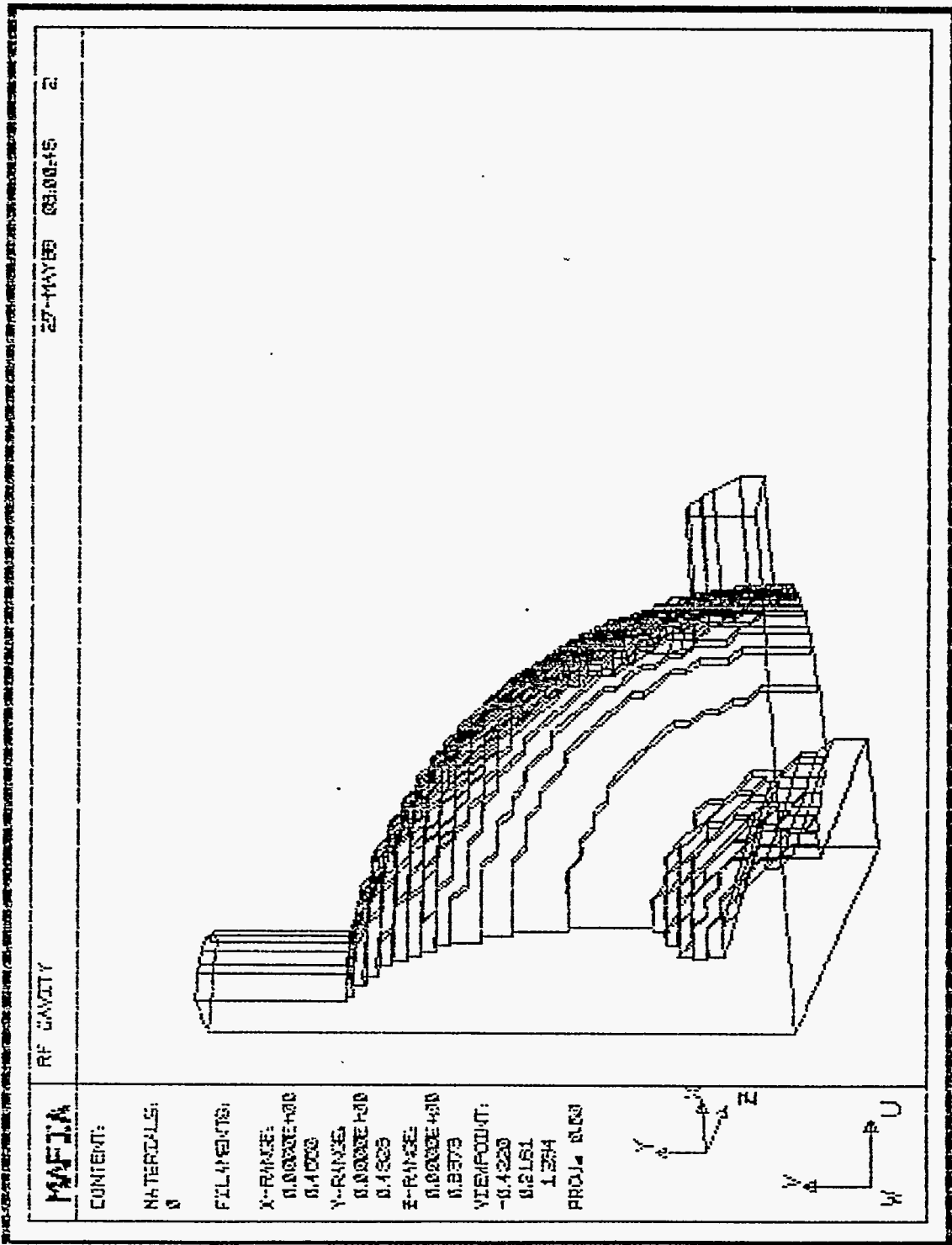

Fig. 6. One-eighth of the prototype cavity with holes.