

NOV 20 1998

SANDIA REPORT

SAND98-2019
Unlimited Release
Printed September 1998

~~MS0619 Review & Approval For
DOE/OSTI (126900) 2/~~

RECEIVED

NOV 27 1998

OSTI

Summary of State-of-the-Art Power Conversion Systems for Energy Storage Applications

Stan Atcitty, Satish Ranade, Amber Gray-Fenner

Prepared by
Sandia National Laboratories
Albuquerque, New Mexico 87185 and Livermore, California 94550

Sandia is a multiprogram laboratory operated by Sandia Corporation,
a Lockheed Martin Company, for the United States Department of
Energy under Contract DE-AC04-94AL85000.

Approved for public release; further dissemination unlimited.



Sandia National Laboratories

Issued by Sandia National Laboratories, operated for the United States Department of Energy by Sandia Corporation.

NOTICE: This report was prepared as an account of work sponsored by an agency of the United States Government. Neither the United States Government nor any agency thereof, nor any of their employees, nor any of their contractors, subcontractors, or their employees, makes any warranty, express or implied, or assumes any legal liability or responsibility for the accuracy, completeness, or usefulness of any information, apparatus, product, or process disclosed, or represents that its use would not infringe privately owned rights. Reference herein to any specific commercial product, process, or service by trade name, trademark, manufacturer, or otherwise, does not necessarily constitute or imply its endorsement, recommendation, or favoring by the United States Government, any agency thereof, or any of their contractors or subcontractors. The views and opinions expressed herein do not necessarily state or reflect those of the United States Government, any agency thereof, or any of their contractors.

Printed in the United States of America. This report has been reproduced directly from the best available copy.

Available to DOE and DOE contractors from
Office of Scientific and Technical Information
P.O. Box 62
Oak Ridge, TN 37831

Prices available from (615) 576-8401, FTS 626-8401

Available to the public from
National Technical Information Service
U.S. Department of Commerce
5285 Port Royal Rd
Springfield, VA 22161

NTIS price codes
Printed copy: A07
Microfiche copy: A01



DISCLAIMER

**Portions of this document may be illegible
electronic image products. Images are
produced from the best available original
document.**

SAND98-2019
Unlimited Release
Printed September 1998

Summary of State-of-the-art Power Conversion Systems for Energy Storage Applications

Stan Atcitty
Energy Storage Systems Department
Sandia National Laboratories
PO Box 5800
Albuquerque, NM 87185-0613

Satish Ranade
Department of Electrical Engineering
New Mexico State University
Las Cruces, NM 88003

Amber Gray-Fenner
Energy Communications Consulting
7204 Marigot Road NW
Albuquerque, NM 87120

Abstract

The power conversion system (PCS) is a vital part of many energy storage systems. It serves as the interface between the storage device, an energy source, and an AC load. This report summarizes the results of an extensive study of state-of-the-art power conversion systems used for energy storage applications. The purpose of the study was to investigate the potential for cost reduction and performance improvement in these power conversion systems and to provide recommendations for future research and development. This report provides an overview of PCS technology, a description of several state-of-the-art power conversion systems and how they are used in specific applications, a summary of four basic configurations for the power conversion systems used in energy storage applications, a discussion of PCS costs and potential cost reductions, a summary of the standards and codes relevant to the technology, and recommendations for future research and development.

Acknowledgements

Sandia National Laboratories would like to acknowledge and thank Dr. Christine E. Platt of the U.S. Department of Energy's Office of Utility Technologies for the support and funding of this work. Appreciation is also extended to Mike Behnke of Trace Technologies (for reviewing Appendix B) and to Russell Bonn and Garth Corey of Sandia National Laboratories; Dr. Mariesa Crow, Associate Professor of Electrical and Computer Engineering at the University of Missouri-Rolla; Dr. Ned Mohan, Professor of Electrical Engineering at the University of Minnesota; and Loren Walker, an independent consultant, for their participation as technical reviewers. We also gratefully acknowledge all of the contributing organizations who participated in this project and contributed to its success.

Contents

<i>Executive Summary</i>	v
<i>Introduction</i>	1
Applications	4
Scope.....	5
<i>PCS Basics</i>	7
Power Stage	7
Controller.....	9
AC Interface and DC Interface.....	10
<i>State-of-the-art PCS Configurations</i>	13
ABB Industrial Systems Concept	13
Abacus Controls Concept.....	14
Advanced Energy Systems Concept	15
Exide Electronics Concept.....	16
Liebert Corporation Concept.....	17
Omion Power Engineering Concept.....	17
Orion Energy Concept.....	19
Soft Switching Technologies Concept.....	20
Trace Technologies Concept	20
Westinghouse Electric Concept	22
Northern Power Systems Concept.....	24
Oak Ridge National Laboratory Concept.....	25
Power Electronics Building Block Concept	27
<i>PCS Configurations Summary</i>	29
Grid-connected Parallel Configuration.....	29
Shunt- and Series-injection Transformers	30
Grid-connected Series Configuration.....	31
Grid-independent Parallel and Series Hybrid Configurations	32
Comparison and Use of PCS Configurations	34
PCS Efficiency	35
<i>PCS Cost</i>	37
Cost Breakdown and Cost Reduction Potential by Application	37
PCS Costs for Power Quality Applications.....	38
PCS Costs for Voltage Regulation Applications.....	39
PCS Costs for Customer Demand Peak Reduction Applications.....	40
PCS Costs for Area Control/Frequency Regulation Applications.....	40

Contents

PCS Costs for Residential Applications	41
PCS Costs for Small Village Applications	41
PCS Costs for Large Village/Small Industrial Applications	42
Discussion of Potential Cost Reductions and Cost-reduction Conclusions	42
<i>Applicable or Relevant Standards and Codes</i>	<i>45</i>
Electrical Equipment Installation Codes.....	45
National Fire Protection Association National Electric Code	45
Underwriters Laboratory	45
Electrical Systems and Interface Codes.....	45
American National Standards Institute/Institute of Electrical and Electronic Engineers	45
Federal Communications Commission.....	46
Other Related Codes and Standards.....	46
National Electric Safety Code	46
International Electrotechnical Commission.....	47
<i>Conclusions</i>	<i>49</i>
<i>Recommendations for Future Research and Development.....</i>	<i>51</i>
<i>Appendix A—List of Companies Interviewed.....</i>	<i>A-1</i>
<i>Appendix B—Inverters</i>	<i>B-1</i>
<i>Appendix C—Semiconductor Switches.....</i>	<i>C-1</i>
<i>Appendix D—Advanced Energy Storage Electrical Interface.....</i>	<i>D-1</i>
<i>Appendix E—R&D Needs: Industry Responses.....</i>	<i>E-1</i>
<i>Appendix F—Acronyms and Abbreviations</i>	<i>F-1</i>
<i>Appendix G—Bibliography and References.....</i>	<i>G-1</i>

Figures

Figure 1. Energy storage system.	1
Figure 2. Graphical representation of real and reactive power.	3
Figure 3. PCS connected to a storage device and an AC load/source.	7
Figure 4. Example of a power stage.....	8
Figure 5. Rectification and inversion.....	8
Figure 6. One possible PCS controller for a grid-connected system.	10
Figure 7. Typical AC interface.....	11
Figure 8. Typical DC interface.	11
Figure 9. ABB power quality, voltage regulation, customer demand peak reduction, and area control/frequency regulation design.	13
Figure 10. Abacus Controls, Inc. TRIMODE power processor hybrid topology.	15
Figure 11. Advanced Energy Systems hybrid inverter design.	16
Figure 12. Exide Electronics on-line UPS design.	16
Figure 13. Liebert Corporation power quality design.	17
Figure 14. AC Battery PQ2000 configuration.	18
Figure 15. AC Battery PM250 configuration.	19
Figure 16. Orion Energy's series hybrid system.	19
Figure 17. Trace 1.3-MVA SMES voltage sag protection design.....	20
Figure 18. Trace 50-kVA voltage regulation and customer demand peak reduction design (proposed).	21
Figure 19. Trace 10-MVA area control/frequency regulation design (proposed).	21
Figure 20. Trace 30-kVA or 250-kVA off-grid hybrid design.....	22
Figure 21. Westinghouse Electric DVR.....	23

Figure 22. Westinghouse Electric DSTATCOM.....	24
Figure 23. Northern Power Systems rotary conversion system.....	25
Figure 24. Multilevel converter used for reactive power (R&D).....	27
Figure 25. Multilevel converter used in a back-to-back intertie (R&D).....	27
Figure 26. The PEBB concept (R&D).....	28
Figure 27. Grid-connected parallel configuration.....	29
Figure 28. Example of a shunt-injection and a series-injection transformer.....	30
Figure 29. Grid-connected series configuration.....	31
Figure 30. Grid-independent parallel hybrid configuration.....	32
Figure 31. Grid-independent series hybrid configuration.....	33
Figure 32. PCS cost breakdown.....	38
Figure 33. Current PCS costs.....	43
Figure 34. Near-term (within approximately two years) cost reduction potential.....	43
Figure B-1. Basic voltage-source inverter with resistive load.....	B-2
Figure B-2. Current-source inverter (with square-wave switching).....	B-3
Figure B-3. Voltage (v) and current (i) in a reactive (inductive) load.....	B-3
Figure B-4. Accommodating reactive loads.....	B-4
Figure B-5. Illustration of how the fundamental, third, fifth, and seventh harmonic components "sum" to approximate a square wave.....	B-5
Figure B-6. Harmonic spectrum corresponding to time waveforms in Figure B-5.....	B-6
Figure B-7. Pulse-width modulation waveform.....	B-6
Figure B-8. Stepped square wave.....	B-7
Figure B-9. Snubber circuit.....	B-9
Figure B-10. Operating quadrants for a basic current-source inverter.....	B-13
Figure B-11. Voltage regulation building blocks.....	B-14
Figure B-12. Series-connected voltage boost inverter.....	B-14
Figure B-13. Unified Power Flow Controller.....	B-15
Figure B-14. Three-phase voltage-source inverter.....	B-16
Figure B-15. Waveform and switching sequence for a three-phase, voltage-source inverter.....	B-16
Figure B-16. Matrix converter.....	B-17
Figure B-17. Single- and three-phase line-commutated converters.....	B-18
Figure B-18. Voltage and current waveforms for a single-phase, line-commutated converter.....	B-19
Figure B-19. Waveforms for a three-phase, six-pulse bridge rectifier.....	B-20
Figure B-20. Twelve-pulse bridge using wye-to-wye and wye-to-delta transformers.....	B-20
Figure B-21. Waveforms for a twelve-pulse bridge inverter.....	B-21
Figure B-22. Basic DC-link soft-switching inverter.....	B-23
Figure B-23. Representative DC-link inverter waveforms under discrete pulse modulation.....	B-24
Figure B-24. Single-phase, three-level voltage-source inverter.....	B-25
Figure B-25. Single-phase, three-level current-source inverter.....	B-25
Figure B-26. Voltage (current) waveform for a three-level voltage-source (or current-source) inverter.....	B-26
Figure B-27. Relationship between the inner and outer control loops.....	B-27
Figure B-28. Sinusoidal PWM.....	B-28
Figure B-29. Hysteresis-based PWM.....	B-29
Figure B-30. Space-vector PWM.....	B-29
Figure B-31. Example circuit for a grid-connected ESS inverter.....	B-30
Figure B-32. Inverter technology by rating and switching frequency.....	B-34
Figure B-33. Inverter taxonomy.....	B-35
Figure C-1. Voltage ratings for commonly used semiconductors.....	C-3
Figure C-2. Current ratings for commonly used semiconductors.....	C-4
Figure D-1. One-line diagram for the PQ VR™ system at the SAAP I Stanger Mill.....	D-1
Figure D-2. Power quality glitch protection configuration.....	D-2

Contents

Figure D-3. CleanSource™ device.....	D-3
Figure D-4. DESS used for UPS applications.....	D-4

Tables

Table 1. PCS Costs by Application.....	viii
Table 2. PCS Characteristics for Grid-connected Energy Storage Systems.....	5
Table 3. PCS Characteristics for Grid-independent Energy Storage Systems.....	5
Table 4. Soft-switched and Multilevel Converters Built and Tested by ORNL.....	26
Table 5. Grid-connected Systems Parallel/Series Configuration Comparison.....	34
Table 6. Grid-independent Systems Parallel/Series Configuration Comparison.....	34
Table 7. Summary of Design Configurations Used by Companies Interviewed.....	34
Table 8. PCS Efficiencies.....	36
Table 9. PCS Costs for Power Quality Applications.....	39
Table 10. PCS Costs for Voltage Regulation Applications.....	39
Table 11. PCS Costs for Customer Demand Peak Reduction Applications.....	40
Table 12. PCS Costs for Area Control/Frequency Regulation Applications.....	40
Table 13. PCS Costs for Residential Applications.....	41
Table 14. PCS Costs for Small Village Applications.....	41
Table 15. PCS Costs for Large Village/Small Industrial Applications.....	42
Table C-1. Controllable Switches.....	C-1
Table C-2. Semiconductor Comparison (normalized).....	C-3

Executive Summary

Introduction

Sandia National Laboratories (SNL) performs technical activities for the Department of Energy- (DOE-) sponsored Energy Storage Systems Program (ESSP). This program focuses on research and development (R&D) of energy storage systems for use by electric utilities and consumers. In the simplest terms, energy storage systems (ESSs) store energy for use when other means of supplying power are unavailable, uneconomical, or when additional power is necessary. In systems that are connected to the utility grid, utility power or another energy source is used to charge the storage device. Then, when an outage or a disturbance occurs, or during times of peak demand, the storage device supplies power to the grid as necessary. In grid-independent systems, power is supplied to the load by a renewable source (or, in hybrid systems, a renewable source and a diesel generator) that also charges the storage device. When power from the renewable source is unavailable, the storage device supplies the necessary power.

The power conversion system (PCS) is a vital part of many energy storage systems. It serves as the interface between the storage device, an energy source or sources, and the load. The load can either be a utility distributing electricity to its customers or a residential, village, or other user who is not grid-connected. An electric utility may also be a source for charging the storage device.

The ultimate goal of future PCS development is to create advanced, multi-technology, low-cost, and low-footprint PCSs. The ideal PCS would be able to interface any or all of the four major storage technologies (batteries, superconducting magnetic energy storage (SMES), flywheels, and supercapacitors) with a renewable power source (grid-independent or hybrid systems), and with the utility grid or a grid-independent load. Many different types of PCSs have been used in or proposed for ESS applications. In many pilot projects, the choice of technology has been based on vendor experience, the desire to investigate an advanced concept, or a specific requirement of the project.

Purpose

The purpose of this study was to investigate the potential for cost reduction and performance improvement in PCSs for ESS applications. A comparative technical study of alternative technologies would lend insight, but is not suited, by itself, to identifying areas of general improvement. This study combined a detailed survey of manufacturers and experts with a comparative analysis that provides the basis for R&D recommendations for PCS technology.

To gather design and cost data, site visits were made to companies who are considered stakeholders in the technology (PCS and component manufacturers, etc.). The following companies were interviewed and participated in detailed discussions of the target applications specified by this report:

- ABB Industrial Systems, Inc.
- Abacus Controls, Inc.
- Advanced Energy Systems

Executive Summary

- Exide Electronics
- Liebert Corporation
- Northern Power Systems (formerly The New World Power Technology Company)
- Omnion Power Engineering Corporation
- Orion Energy Corporation
- Soft Switching Technologies Corporation
- Trace Technologies Corporation
- Westinghouse Electric Corporation

Scope

The ESSP has identified seven target applications toward which future PCS development should be directed (Butler). These applications are thought to offer the highest potential cost savings to the user, to be the most likely to be commercialized in the near term, and to have the greatest potential impact on industry. Four of the target applications are grid-connected:

- **Power Quality**—The ability to mitigate or prevent voltage sags, voltage spikes, and momentary power outages.
- **Voltage Regulation**—The ability to maintain voltages at the load within 5% of normal voltage.
- **Customer Demand Peak Reduction**—The ability to store off-peak power for a customer to dispatch during on-peak demand periods as a way to reduce monthly demand charges.
- **Area Control/Frequency Regulation**—The ability for grid-connected utilities to prevent the unplanned transfer of power between themselves and the neighboring utilities (area control); and the ability for isolated utilities to prevent the frequency of the electricity that they produce from deviating too far from 60 Hz (frequency regulation).

The remaining three target applications are grid-independent:

- **Residential**—The ability to provide up to 12 kWh of storage for power ranges from 1 to 5 kW.
- **Small Village**—The ability to provide 120 kWh of storage for power ranges from 5 to 30 kW.
- **Large Village/Small Industrial**—The ability to provide 250 kWh of storage for power ranges greater than 30 kW.

Each of these seven applications has different system requirements. The limitations of the storage technology and the demands of the application must be considered when planning PCS development. It is tempting to ask whether a “one-size-fits-all” PCS is possible, but this question is not specifically considered in this study. Whether or not the “one-size” concept is possible or practical, the opportunities for reducing the system cost of future PCSs is the focus of this report.

To more specifically discuss the direction future PCS development should take, it was first necessary to gain an understanding of the current state-of-the-art of existing PCS technology. This report focuses on the PCSs used to interface the following energy storage and renewable technologies to electricity networks and grid-independent loads:

- Batteries
- SMES
- Flywheels
- Supercapacitors
- Photovoltaics (PV)
- Wind

This report does not discuss the benefits of specific renewable or storage technologies. The report does, however, describe several different methods for configuring a PCS for energy storage applications, some of which include renewable technologies.

The main body of the report presents current and proposed PCS system configurations provided by the companies interviewed. Additionally, power converter R&D that is currently being conducted by Oak Ridge National Laboratories (ORNL) and related research (the Power Electronics Building Block, or PEBB, concept—a cooperative effort being led by the Office of Naval Research) are also reviewed. This report focuses on technologies discussed by the companies interviewed and does not attempt to include all possible system configurations.

PCS Overview

Generally, there are four major components in an energy storage system: the storage device, the PCS, the energy source (e.g., utility power), and the load. The PCS can be broken down into four major subcomponents—the power stage, the controller, the DC interface, and the AC interface. The DC interface, the AC interface, and the system's magnetic components are sometimes collectively referred to as the "balance of system" (BOS). The primary magnetic components in the PCS are transformers, filter inductors, DC-link inductors, resonant-link inductors, and resonant-pole inductors.

Most state-of-the-art PCS designs fit in one of the following four configuration categories:

- Grid-connected parallel configuration
- Grid-connected series configuration
- Grid-independent parallel hybrid configuration
- Grid-independent series hybrid configuration

In a grid-connected parallel configuration, the energy storage system is connected in parallel with the utility to the load. In a grid-connected series configuration, the energy storage system is connected in series with the utility to the load. Grid-connected series configurations are generally called on-line or double-conversion systems. On-line refers to a PCS that is continually in use; in other words, it is always "on line" to the load. Double-conversion refers to systems that convert power twice, once from AC to DC and then again from DC to AC. The primary distinction between grid-independent systems using parallel and series hybrid configurations is how the engine generator is tied into the overall system. In a parallel hybrid

Executive Summary

configuration the engine generator is tied directly to the AC load. In a series hybrid configuration the engine generator is tied to the DC link of the PCS.

PCS Costs

One of the major barriers to widespread use of any emerging technology is high cost. The extent to which the PCS can interface with the energy storage device and the energy source, and how the PCS interfaces to the load, depends on design tradeoffs that are specific to the application for which the system is designed. Obviously, the more functions required of the PCS, the more likely the cost to the customer will increase.

The PCS cost ranges from 20% to 60% of the energy storage system (Akhil). In applications where the ESS must supply power for extended periods of time, the energy storage requirement is substantial and the cost of the energy storage device dominates. In other applications, the energy storage device is small and is only required to supply power for a short period of time. In these instances the PCS cost becomes significant. Consequently, reducing PCS cost and/or improving performance can contribute to making energy storage systems a more commercially viable technology.

The ESSP developed a cost breakdown structure for state-of-the-art PCS systems. PCS companies were contacted and estimated cost breakdowns were discussed. Some suppliers were reluctant to give detailed cost information.

The PCS cost was broken into four major cost centers—power stage, device drivers, PCS controller, and balance of system (BOS). The companies interviewed were asked to provide the total cost of the PCS. Additionally, manufacturers were asked to provide a percentage of the total cost for each of the major cost centers and to discuss potential near-term (less than two years) cost reductions.

The PCS cost ranges for each of the seven target applications are presented in Table 1. Most of the applications had a wide cost range. Additionally, the cost estimates for PCSs used in area control/frequency regulation applications were highly speculative. In general, grid-independent systems seem to cost more than grid-connected systems (\$60 to \$750/kW for grid-connected systems, \$200 to \$1200/kW for grid-independent systems).

Table 1. PCS Costs by Application

Application	\$/kW
Power Quality	\$60 - \$400
Voltage Regulation	\$150 - \$500
Customer Demand Peak Reduction	\$420 - \$750
Area Control/Frequency Regulation	\$80 - \$320
Residential	\$700 - \$1200
Small Village	\$790 - \$858
Large Village/Small Industrial	\$200 - \$647

Potential Cost Reductions

Some PCS manufacturers are advancing the concept of modular PCSs to reduce costs. The modular concept uses inverters connected in series and/or parallel to achieve higher ratings.

These manufacturers feel that lower-power PCSs are probably easier and cheaper to produce and can be networked together using software to achieve the same rating as a single high-power PCS. Increased component integration and functionality per unit area, such as that which could be achieved by replacing analog components with digital components in controller circuits, could also result in cost reductions as well as a smaller package. Some cost reductions may also be realized from advances in semiconductors. Possibly the greatest cost reduction in PCS development would come from combining modular semiconductor switching devices with advanced microprocessor controllers. The trend in industry appears to be toward modular component designs that use advanced controllers; for example, some manufacturers are placing the entire inverter power stage in a single package with one heat sink. This standardization of a single, modular package that can be used for a variety of applications by slightly modifying the software could reduce or eliminate the need for custom-designed PCSs.

These potential cost reductions require design enhancements that can increase the initial cost of the PCS. However, the cost of PCS components and subassemblies is generally on a downward trend. Advances in technology are expected in the areas of packaging, semiconductors, and power conversion topologies. These advances may help reduce the number of parts required and the size of the units, and combined with increased demand and higher production, will probably result in lower PCS costs in the future.

Standards and Codes

The design, installation, and operation of electrical equipment is governed by standards and codes. Requirements dictated by such standards directly affect the cost of equipment and systems. Other than UPSs, which are widely used, only a small number of energy storage systems are currently operating in the United States. Consequently, specific standards and codes have not been developed for systems other than UPSs, or for the inverters used in these systems. Pending the development of specific standards, several existing standards and codes may be considered to apply to energy storage systems and inverters.

Electrical equipment installation codes pertain to electrical equipment, rather than entire systems. The prevalent codes in the US are the National Fire Protection Association (NFPA) National Electrical Code (NEC), Articles 70 and 690; and Underwriters Laboratory (UL), Article UL1741. Electrical systems and interface codes apply to the installation of entire systems and the system's interface to a utility grid and/or the load. The relevant codes are American National Standards Institute (ANSI)/ Institute of Electrical and Electronics Engineers (IEEE), IEEE-1001, 519-1992, 928-1986, 929-1988, and WG 5; and Federal Communications Commission (FCC), Part 15, Subpart J. Other codes that may be relevant are the National Electric Safety Code (NESC), Sections 9, 12, and 14 and the 60000 series of the International Electrotechnical Commission (IEC).

Conclusions and Recommendations

The following general observations were made during the course of this study:

- The UPS area is a mature example of energy storage systems and cost-effective and reliable PCSs.
- Most fielded systems use tried and proven inverters.

Executive Summary

- Most fielded systems require one-of-a-kind controllers.
- Fielded systems at 500 kVA and below generally use IGBTs and hard-switched bridge topologies.
- Systems in excess of 10 MW generally use SCRs and GTOs.
- There are very few fielded ESSs in the 1- to 10- MW range. The lack of technology in this range may be because (1) it is convenient to keep pilot projects in the lower kVA range, (2) this range requires higher voltage/current devices, and/or (3) the market potential in this range is unclear.
- Higher power ratings could be achieved using a modular approach in which PCSs are connected in series/parallel arrangements, but few demonstrated systems have used this approach.
- Soft switching is becoming a mature technology in the 250-kVA range and can provide advantages over hard switching.
- Higher-rated devices that can switch at high frequencies would be beneficial.
- Topologies such as multilevel converters could be beneficial.
- The cost centers that were identified as having potential for cost reduction are the power stage, the controller, and the BOS (specifically, the magnetic components).

Additionally, two analogies can be drawn with respect to the current state of PCS development and technology. First, PCSs are now at the state that personal computers were in the early 1980s—they are highly-proprietary, and thus, very expensive. During the meetings with industry, a great deal of discussion focused on how to reduce the costs of building PCSs for, and integrating PCSs with, energy storage technologies. It is thought that with greater standardization of PCS components and entire PCS designs the costs will be reduced.

The second analogy is taken from the automotive industry. From the discussions with the PCS industry, it is not clear whether customers need a high-end, and consequently high-dollar, “luxury” model converter or if a simpler, and cheaper, “basic transportation” model will do. The converters that are currently being manufactured are expensive, engineering-intensive devices that have a wide range of available features and options. It is not clear from the study whether such devices are “necessary” (required by the customer for specific reasons) or are simply the result of enthusiastic engineering.

Of interest is whether customers (system integrators and end users) would use more economical, “basic transportation” converters. Presently, the market for PCSs is still relatively small and not well-defined. Additionally, a “Model T” of converters apparently has not been developed. It is not clear if the development of a mass market, affordable converter that could be used for a wide variety of applications would do for the PCS market what the Model T did for the automobile market, but it is a question worth exploring. Currently, however, a question also exists as to the actual cost benefits of the low end converters. Unlike the Model-T, it is not clear at this time that providing a converter with minimal specifications would dramatically reduce its cost.

Based on this study, the following recommendations are made:

- Support the near-term development of high-power semiconductor switches.
- Explore the options available for developing cheaper, lighter, and smaller magnetics, and for reducing losses for filter inductors and line-frequency transformers.
- Research advances in PCS controllers for hybrid ESSs, including reducing software development time and cost.
- Encourage R&D into advanced converter concepts specifically for energy storage applications.
- Support the development of standards and codes specifically related to the PCSs used with energy storage systems and renewables.

Introduction

Sandia National Laboratories (SNL) performs technical activities for the Department of Energy- (DOE-) sponsored Energy Storage Systems Program (ESSP). This program focuses on research and development (R&D) of energy storage systems for use by electric utilities and consumers. The ESSP's vision is that "energy storage will be highly valuable in enabling the 21st century utility, in a competitive environment, to efficiently provide low-cost, reliable, environmentally-benign service to a broad spectrum of electricity users."

Since its origins in the 1970s, the ESSP has evolved to meet the changing needs of the nation. It began with an emphasis on developing diverse components, but in the 1980s the emphasis switched specifically to battery storage subsystems. In the 1990s integration with the utility grid and field tests of turnkey systems were the Program's focus. The Program is currently being driven by the need for reliability (ensuring power quality and reliability for end-users), renewables (enabling the increased utilization of wind and photovoltaic power), and productivity (enhancing productivity by increasing efficiency and cost-effectiveness). The emphasis now is on working to develop integrated storage systems for a variety of grid-connected and grid-independent applications.

In the simplest terms, energy storage systems (ESSs) store energy for use when other means of supplying power are unavailable or when additional power is necessary. In systems that are connected to the utility grid, utility power (or possibly another energy source) is used to charge a storage device. Then, when an outage or disturbance occurs, or during times of peak demand, the storage device supplies power to the grid as necessary. In grid-independent systems, power is supplied to the load by a renewable source (or, in hybrid systems, a renewable source and a diesel generator) that also charges the storage device. When power from the renewable source is unavailable, the storage device or the diesel generator supplies the necessary power.

The power conversion system (PCS) is a vital part of all energy storage systems. It is used to interface between the storage device, the energy source or sources, and the load (see Figure 1). The load can either be a utility distributing electricity to its customers or a residential, village, or other user who is not grid-connected. An electric utility may also be a source for charging the storage device.

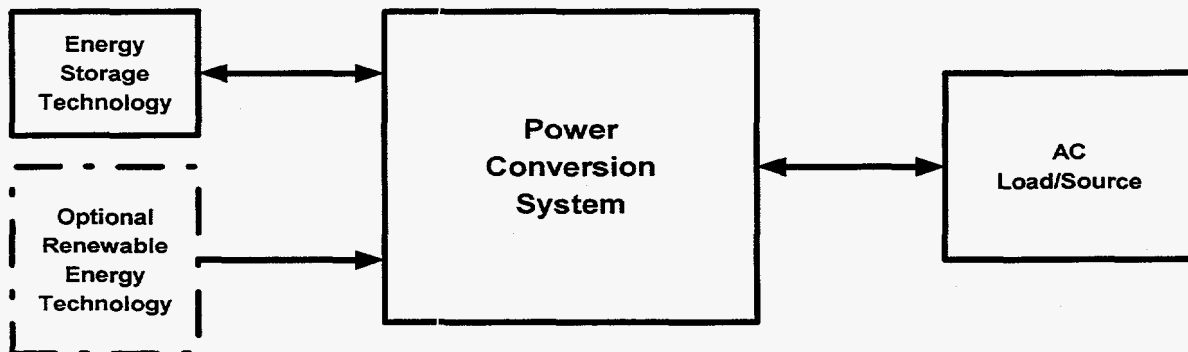

Figure 1. Energy storage system.

Introduction

The primary function of the PCS is to transform stored and renewable energy into energy that can be used at the load. Generally this means converting direct current (DC) into alternating current (AC) at a specific frequency (usually 60 Hz, the standard operating frequency for U.S. utilities). This is done by making the output sinusoidal. "In a simple form, the PCS inverter takes power from a DC source and uses high-power switching devices to form a sinusoid. The PCS switches rapidly between the positive and negative DC voltage supply, creating a sinusoidal output." (Mohan, et al.)

In DC systems, such as a battery, the *steady-state* voltage and current do not change with time. (Of course, the voltage and current do change as the operating conditions change, e.g., the battery discharges.) The power supplied by the battery is the rate at which energy is delivered, and equals the product of the voltage and current. This power is constant in time and corresponds to work done per unit time (and losses in the system).

In AC systems, such as an electric utility, the steady-state voltage and current are sinusoidal functions of time that have a constant amplitude. The power supplied, which equals the product of voltage and current, thus oscillates in time. The average of this oscillating power corresponds to work done per unit time and losses in the load, and is called "real" or "active" power. Real (or active) power (P) is measured in watts (W). Real power is the product of the voltage magnitude (V), current magnitude (I), and the cosine of the phase angle (θ) between the two. Real power can be represented by the following equation:

$$P = V * I * \cos(\theta) \quad (1)$$

Thus, if voltage and current are in phase ($\theta=0^\circ$) the utility delivers real power; if they are exactly opposite in phase ($\theta=180^\circ$) the utility absorbs real power. Intermediate phase angles correspond to situations in which the load contains capacitors and inductors. In these cases, a portion of the oscillatory component of energy corresponds to the need to charge and discharge these components in the AC cycle. Reactive power (Q)—the product of voltage magnitude, current magnitude, and the sine of the phase angle between the two—is defined to measure this portion of the oscillatory component. Reactive power is measured in volt-amperes reactive (VAR). Reactive power can be represented by the following equation:

$$Q = V * I * \sin(\theta) \quad (2)$$

Reactive power for a source or load is positive when voltage leads the current, and negative when voltage lags the current. Apparent power (S) is defined as the product of voltage magnitude and current magnitude. Apparent power is measured in volt-amperes (VA). The magnitude of apparent power ($|S|$) equals the square root of the sum of real power squared and reactive power squared as shown in Equation 3. Apparent power thus gives a feel for the "size" of a system or component. PCSs are typically given ratings of kVA or MVA.

$$|S| = \sqrt{P^2 + Q^2} \quad (3)$$

Reactive power is important for two reasons. First, as Equation 3 indicates, the size of the system increases if the system must supply or absorb reactive power. Reactive power also has a significant influence on voltage in AC systems. Electric utility systems deliver power via essentially inductive transmission lines. Therefore, a load that absorbs reactive power

makes voltages decrease or drop, while a load that delivers reactive power makes the voltages increase or rise.

The inverter, in the process of converting DC voltage or current to AC, also provides a means to adjust the direction or polarity of voltage/current on the DC side as well as the magnitude and phase relationship of voltage/current on the AC side. Consequently, the inverter can control the direction of real power flow. The concept of real and reactive power is illustrated in Figure 2.

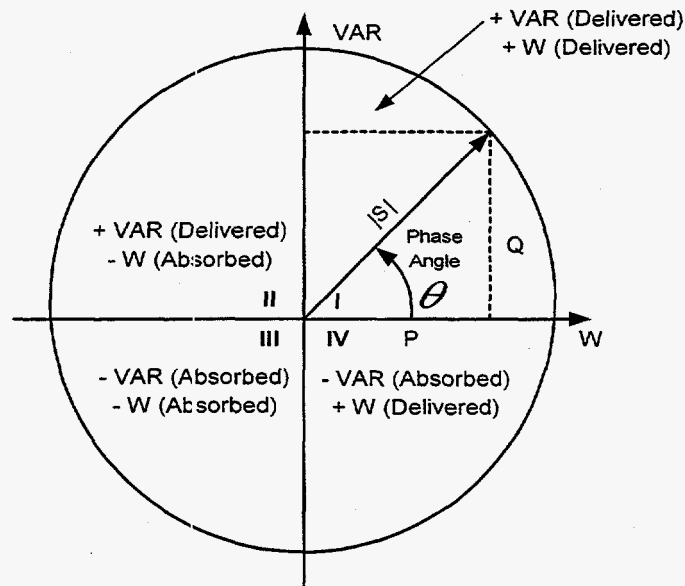

Figure 2. Graphical representation of real and reactive power.

The inverter thus uses the energy in a storage system to deliver real and reactive power as might be needed by an AC load. Additionally, by controlling reactive power the inverter also provides a means to control voltage in grid-connected applications. The PCS can also be used when the energy storage device (e.g., a battery) is being charged. During charging, AC power is converted to DC, a process known as rectification.

“Converter” is a general term used to describe the following four types of power conversion: AC to AC, AC to DC (rectification), DC to DC, and DC to AC (inversion). Power conversion can be achieved in one of two ways—by solid-state switching devices or by rotating machines, such as motors and generators. A PCS that uses rotating machines is known as a “rotating” converter. A PCS that uses solid-state switches is known as a “static” converter (Krein). Although PCS technology is not limited to static conversion, the solid-state devices are the predominant choice of industry and will most likely continue to dominate because of continued progress in semiconductor technology. Consequently, this report focuses on static converter technology, although one rotary conversion technology is discussed.

Introduction

Applications

The ESSP has identified seven target applications toward which future PCS development should be directed (Butler). These applications are thought to offer the highest potential cost savings to the user, to be the most likely to be commercialized in the near term, and to have the greatest potential impact on industry. Four of the target applications are grid-connected:

- **Power Quality**—The ability to mitigate or prevent voltage sags, voltage spikes, and momentary power outages.
- **Voltage Regulation**—The ability to maintain voltage at the load within 5% of normal voltage.
- **Customer Demand Peak Reduction**—The ability to store off-peak power for a customer to dispatch during on-peak demand periods as a way to reduce monthly demand charges.
- **Area Control/Frequency Regulation**—The ability for grid-connected utilities to prevent the unplanned transfer of power between themselves and the neighboring utilities (area control); and the ability for isolated utilities to prevent the frequency of the electricity that they produce from deviating too far from 60 Hz (frequency regulation).

The remaining three target applications are grid-independent:

- **Residential**—The ability to provide up to 12 kWh of storage for power ranges from 1 to 5 kW.
- **Small Village**—The ability to provide 120 kWh of storage for power ranges from 5 to 30 kW.
- **Large Village/Small Industrial**—The ability to provide 250 kWh of storage for power ranges greater than 30 kW.

Each of these seven applications has system requirements. The applications and their characteristics are summarized in Table 2 and Table 3. The limitations of the storage technology and the demands of the application must be considered when planning PCS development. It is tempting to ask whether a “one-size-fits-all” PCS is possible, but this question is not specifically considered in this study. Whether or not the “one-size” concept is possible or practical, the opportunities for reducing the system cost of future PCSs is the focus of this report.

The ultimate goal of future PCS development is to create advanced, multi-technology, low-cost, and low-footprint PCSs. The ideal PCS would be able to interface any or all of the four major storage technologies (batteries, superconducting magnetic energy storage (SMES), flywheels, and supercapacitors) with a power source (grid-independent or grid-connected systems), and with the utility grid or a grid-independent load.

Table 2. PCS Characteristics for Grid-connected Energy Storage Systems

Application	Duration Requirement	Power Range	AC Voltage Range	Storage Technology
Power Quality	< 15 min	1 - 10 MW	480 V - 12.5 kV	Batteries SMES Flywheels Supercapacitors
Voltage Regulation	< 15 min	1 MVAR	12 kV - 34.5 kV	Batteries SMES Flywheels
Customer Demand Peak Reduction	~ 2 hrs	1 MW	480 V - 12 kV	Batteries Flywheels
Area Control/ Frequency Regulation	< 1 hr	10 MW	12 kV - 138 kV	Batteries Flywheels

Table 3. PCS Characteristics for Grid-independent Energy Storage Systems

Application	Storage Requirement	Power Range	AC Voltage Range	Storage Technology
Residential	12 kWh	1 - 5 kW	120 V - 480 V	Batteries Flywheels
Small Village	120 kWh	5 - 30 kW	120 V - 480 V	Batteries Flywheels
Large Village/ Small Industrial	250 kWh	> 30 kW	120 V - 480 V	Batteries Flywheels

Scope

To more specifically consider the direction future PCS development should take, it was first necessary to gain an understanding of the current state-of-the-art of existing PCS technology. This report focuses on the PCSs used to interface the following energy storage and renewable technologies to electricity networks and grid-independent loads:

- Batteries
- SMES
- Flywheels
- Supercapacitors
- Photovoltaics (PV)
- Wind

This report does not discuss the benefits of specific renewable or storage technologies. The report does, however, describe several different methods for configuring a PCS for energy storage applications, some of which include renewable technologies. It was observed that these configurations generally could be separated into distinct categories based on the type(s) of applications for which they are used. A summary of these configuration categories is provided.

Finally, one of the major barriers to widespread use of any emerging technology is cost. The extent to which the PCS can interface with the energy storage device and the utility and/or

Introduction

renewable energy source, and how the PCS interfaces to the load, depends on design tradeoffs that are specific to the application for which the system is designed. Some specific topologies (PCS designs) used in various applications will be discussed later in the report. Obviously, the more functions required of the PCS the more likely the cost to the customer would increase.

A discussion of the current costs of PCSs is included. To gather the design and cost data, site visits were made to companies who are considered stakeholders in the technology (PCS and component manufacturers, etc.). Appendix A contains a list of the companies who were visited. The last section of the report contains conclusions and recommendations for future R&D based on the assessment of the state-of-the-art and the corresponding cost data.

PCS Basics

Generally, there are three major components in an energy storage system: the storage device, the PCS, the energy source (e.g., utility power), and the load. The PCS can be broken down into four major subcomponents—the power stage, the controller, the DC interface, and the AC interface (Figure 3). The DC interface, the AC interface, and the system's magnetic components are sometimes collectively referred to as the “balance of system” (BOS). The primary magnetic components in the PCS are transformers, filter inductors, DC-link inductors, resonant-link inductors, and resonant-pole inductors. The four subcomponents are discussed in more detail below.

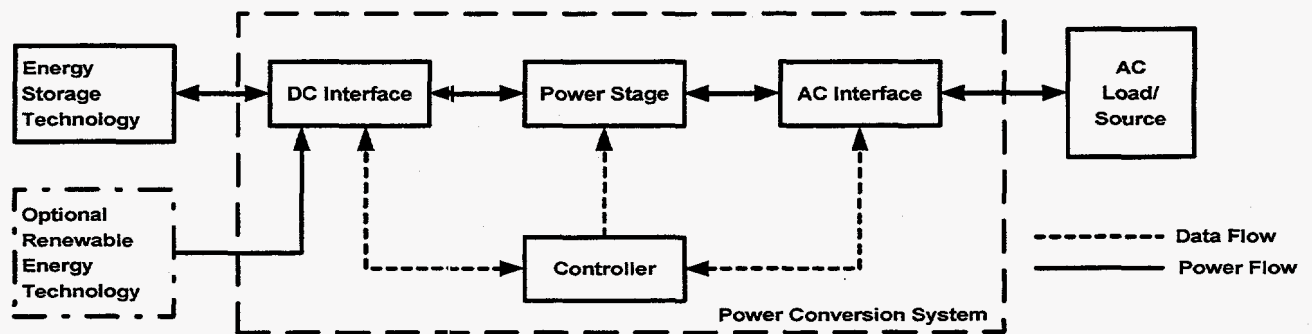

Figure 3. PCS connected to a storage device and an AC load/source.

Power Stage

The heart of the PCS is the power stage. In the energy storage systems discussed in this report, the power stage acts mainly as an inverter—it converts DC power from the storage device to AC power (such as that supplied by the utility grid). The power stage also acts as a rectifier that converts AC (utility) power to DC for charging the storage device. An example of a typical power stage is shown in Figure 4. In general, the power stage consists of the physical topological connection of power semiconductor devices (the “topology”), semiconductor device drivers, thermal management devices, and protective circuits such as snubbers (if required). Snubbers are used in power electronics to limit the rate-of-rise of current or voltage that could potentially destroy the semiconductor device.

PCS manufacturers build three basic types of power stages—line-commutated and self- and force-commutated. A line-commutated power stage uses the utility power frequency as the reference signal to form the sinusoidal output voltage. Line-commutated power stages generally cannot operate without a utility source and always absorb reactive power. Self- and force-commutated power stages can provide current at any phase angle relative to the utility voltage and can deliver power (from storage or renewables) even in the absence of a utility source. The self-commutated power stage can supply real power (Watts) and reactive power (VARs) for residential and grid-independent systems. A more thorough discussion of inverters is provided in Appendix B.

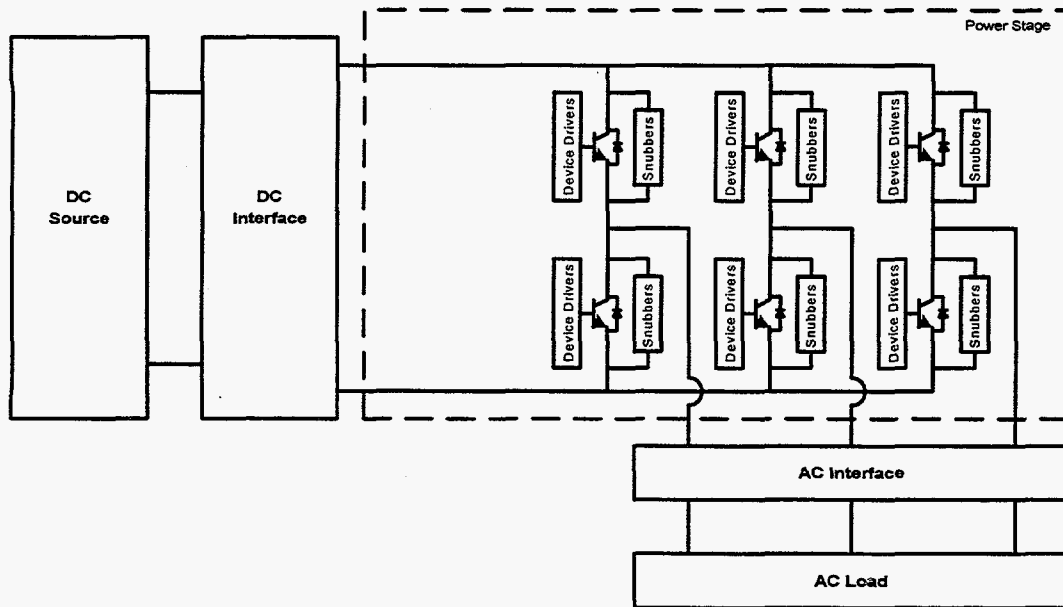

Figure 4. Example of a power stage.

Most PCSs depend on solid-state switching devices to permit or inhibit the flow of current through specialized circuits that invert and rectify electrical signals. An “ideal” AC source changes with time and is depicted graphically as a sine wave. An “ideal” DC source doesn’t change with time and is depicted graphically as a horizontal line. To invert means to convert a DC source to an AC source (see Figure 5). When the storage medium is in a discharge mode, the power stage acts as an inverter to supply power to the utility by converting the DC power supplied by the system to AC. When the energy storage device is being charged, the power stage acts as a rectifier to change the AC into DC for use by the storage device.

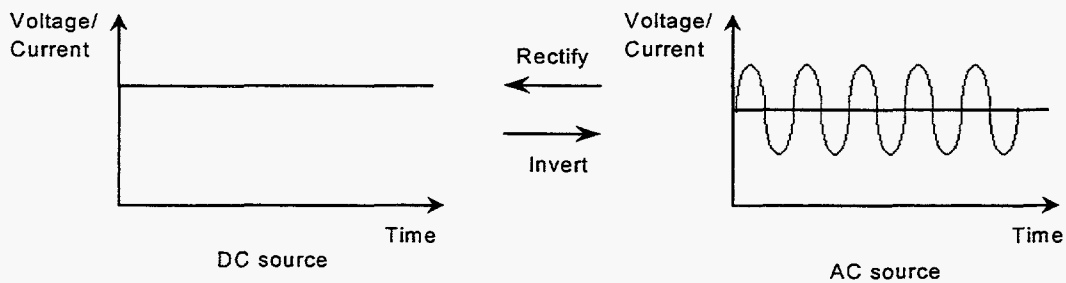

Figure 5. Rectification and inversion.

The complexity of the power stage varies depending on the system’s design requirements (which depend on the application for which the system is being designed). The voltage rating, current rating, and switching frequency of a solid-state switch are used to determine which switch best meets the system’s requirements. The power electronics used in ESSs for utility applications generally are based on one of three types of electronic switches—silicon-controlled rectifiers or thyristors (SCRs), insulated-gate bipolar transistors (IGBTs), or gate-turn off thyristors (GTOs). In high-power systems (10 MW or higher), the available switching devices are limited to the SCR and the GTO. For systems with lower output power ranges, faster devices, such as IGBTs, can be used. For example, in many industrial

applications IGBTs are commonly used for systems with output ranges up to 750 kW, while for higher output levels GTOs are used. Grid-independent systems typically use IGBTs with ratings from 5 to 250 kW. Continued progress in semiconductor technology towards higher voltage ratings, current ratings, and switching frequencies has resulted in the development of new types of solid-state switches such as integrated gate-commutated thyristors (IGCTs), MOS turn-off thyristors (MTOs), and MOS-controlled thyristors (MCTs). A more thorough discussion of switch types and their corresponding applications is provided in Appendix C.

The power rating of a PCS is limited by the power rating of the semiconductor switches used, by the power rating of the associated magnetics, and by the ability to transfer the heat generated by the electronic devices. The PCS designer must make tradeoffs between voltage and current to achieve a given power level. In general, the tradeoffs tend to favor higher voltage and lower current, because the heat dissipated is a direct function of the current, and lower current means smaller heat sinks.

Controller

The controller compares the output of the PCS with a desired or a reference value, and minimizes the error between the two. The power flow in a bidirectional system is reversible. The controller can be analog, digital, or both. The controller generally is divided into three loops—the inner loop, the outer loop, and the functional control loop. The inner loop typically controls the current delivered to the utility and, in a bidirectional inverter, to the energy storage device. The outer control loop controls the output requirement at the load (voltage, MW, MVAR, amperes, and frequency), for example by setting the desired current. The functional control loop (also known as the supervisory control loop) regulates the relationship between the PCS and the other system components, for example determining when to charge and discharge battery banks. The controller is typically microprocessor-based or an analog-digital hybrid and has five major functions:

- To send control signals to the semiconductor device drivers,
- To generate the switching waveform,
- To control the current provided to the load via the inner control loop,
- To manage power, such as performing voltage or power regulation at the utility, via the outer control loop, and
- To control the overall system configuration, such as the charge and discharge rate of batteries, via the functional control loop.

An example of a controller used in a grid-connected system is shown in Figure 6. Recent advances in microelectronics have led to more sophisticated control circuit designs. The recent trend from manufacturers is to replace slower controls with faster microprocessor-based control systems. Different manufacturers may design different systems depending on the system requirements. A more detailed discussion of PCS controllers is provided in Appendix B.

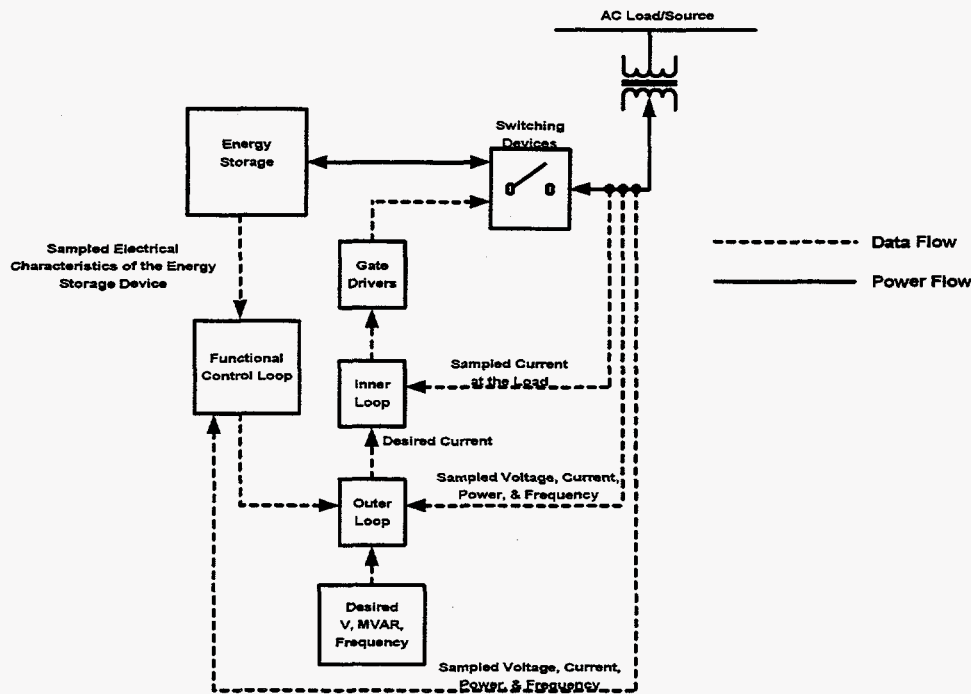

Figure 6. One possible PCS controller for a grid-connected system.

AC Interface and DC Interface

The AC interface may consist of current sensors, inductors, voltage sensors, circuit breakers, fuses, surge arrestors, an AC isolation switch, and a transformer. An example of a typical AC interface is shown in Figure 7. The current sensor is used to detect AC current at the output of the PCS. Inductors are used to buffer dynamic current changes. Voltage sensors are used to detect instantaneous voltages at the output of the PCS. Circuit breakers and fuses are used for overcurrent situations and in case the system needs to be disconnected or turned off quickly. Surge arrestors are used to reduce overvoltage situations that could result from lightning strikes on the utility system. The AC isolation switch is used to isolate the utility and the PCS. The transformer is typically a step-up transformer that increases the PCS output voltage levels to the voltage levels desired by the utility. AC capacitors as shown are almost always used in grid-independent applications and are often needed on grid-connected systems, sometimes in the form of filters, to bypass harmonic currents.

The DC interface hardware usually consists of fuses, current and voltage sensors, isolating switches, a surge arrestor, an electromagnetic interference (EMI) filter, and additional filters. A diagram of a basic DC interface is shown in Figure 8. The fuse is used to disconnect DC circuits in the event of an overcurrent. The current and voltage sensors are used to detect instantaneous DC voltage and current. Isolating switches are used to disconnect the DC devices and the PCS. The surge arrestor is used for overvoltages that may be caused by the DC devices. The EMI filter attenuates PCS-generated electronic switching noise.

One example of additional filters is electrolytic capacitors. These capacitors, also known as DC-link capacitors, are usually series and/or parallel connected to achieve the correct amount of capacitance needed in a PCS design. The DC-link capacitor provides the source voltage or current for the PCS and also reduces ripple in the DC voltage.

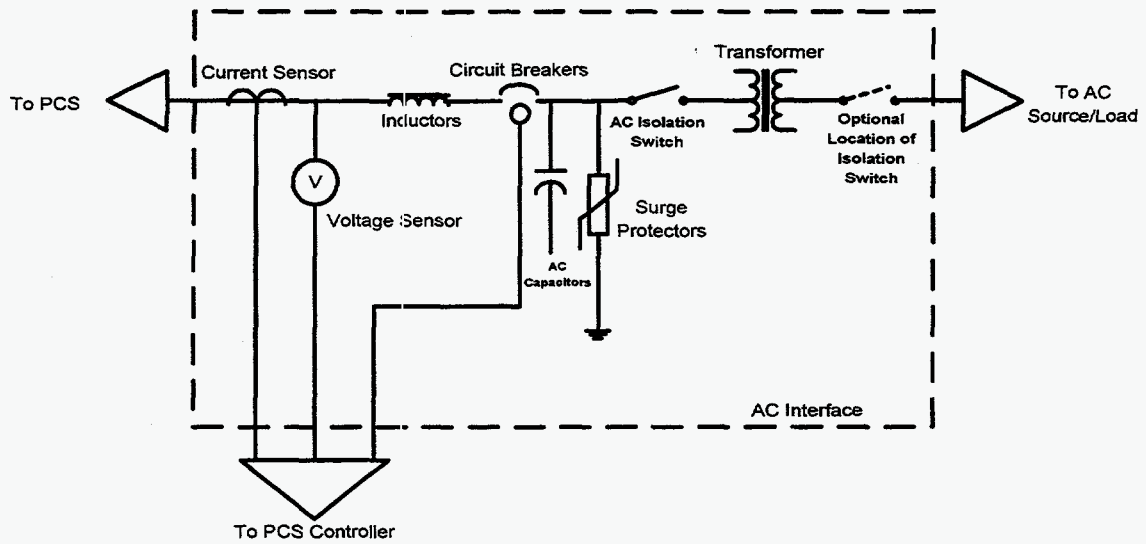

Figure 7. Typical AC interface.

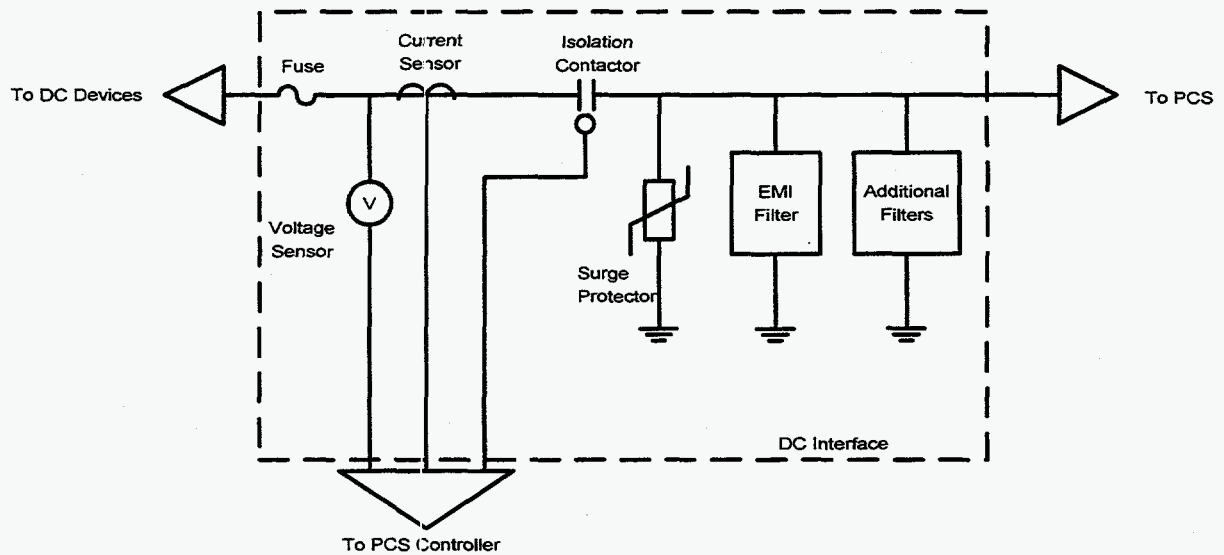
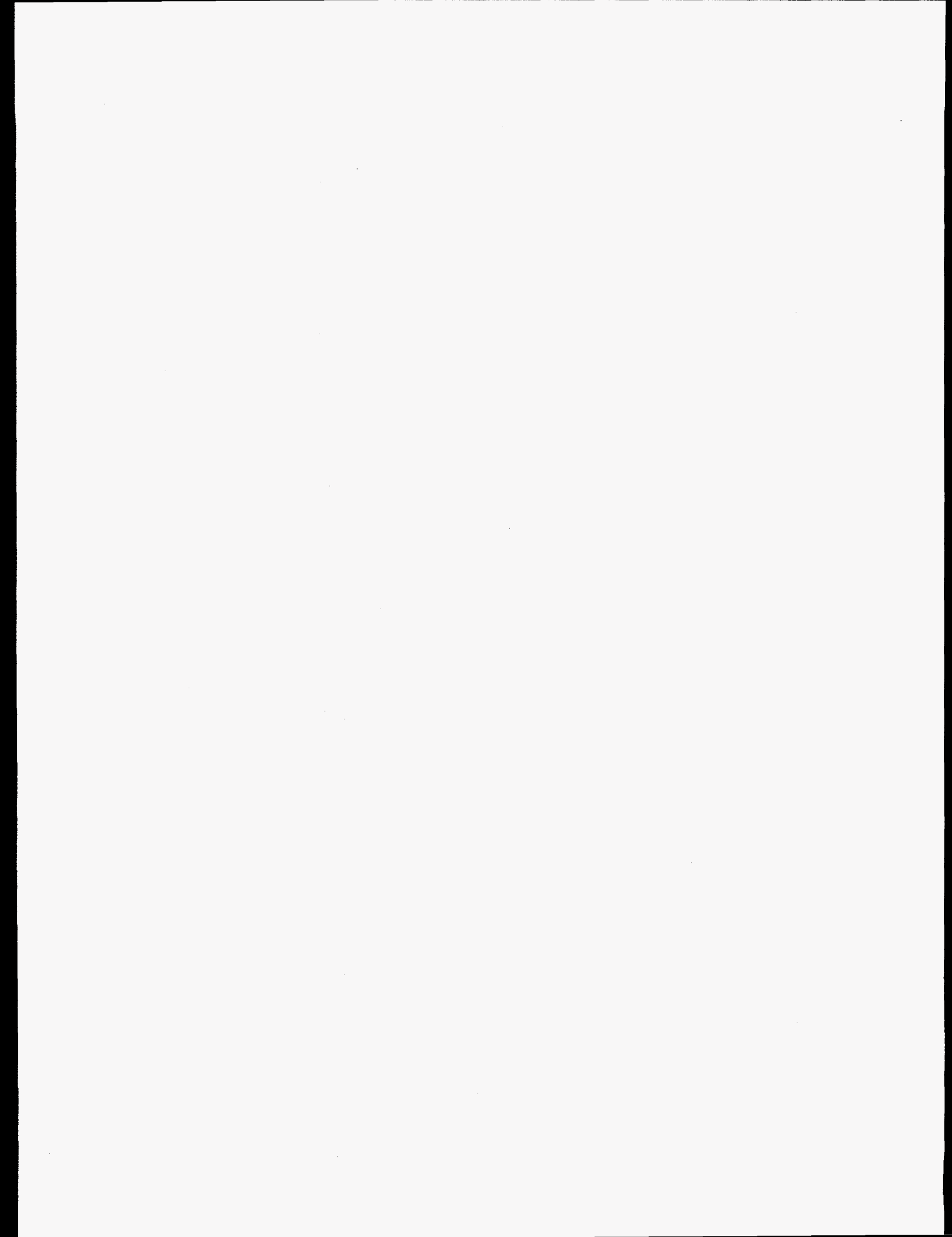

Figure 8. Typical DC interface.



State-of-the-art PCS Configurations

Ten PCS firms were interviewed and participated in detailed discussions of the target applications specified by this report. This section presents current and proposed state-of-the-art system configurations provided by the organizations interviewed. Proposed systems (those not currently on the market) are noted in the figure captions. A summary of all the configurations presented is provided in the next section of this report. Additionally, power converter R&D that is currently being conducted by Oak Ridge National Laboratories (ORNL) and separate research (the Power Electronics Building Block, or PEBB, concept—a cooperative effort being led by the Office of Naval Research) are also reviewed. This report focuses on technologies discussed by the organizations interviewed and does not attempt to include all possible system configurations. Additional examples of specific systems that are currently being fielded or are on the market, and that incorporate advanced storage technologies (SMES, flywheels) are provided in Appendix D.

ABB Industrial Systems Concept

ABB Industrial Systems' power conversion systems are used in a variety of utility applications. Some applications include utility frequency conversion; AC-to-AC interties; DC-to-utility frequency power conversion for fuel cells, photovoltaics, high-speed generators, etc.; battery energy storage and SMES applications; and three-phase to two-phase conversion. ABB has proposed SMES and battery applications for power quality (1-MW and 10-MW systems), voltage regulation (1-MVAR system), customer demand peak reduction (1-MW system), and area control/frequency regulation (10-MW system). The design shown in Figure 9 is the same for all of the applications discussed.

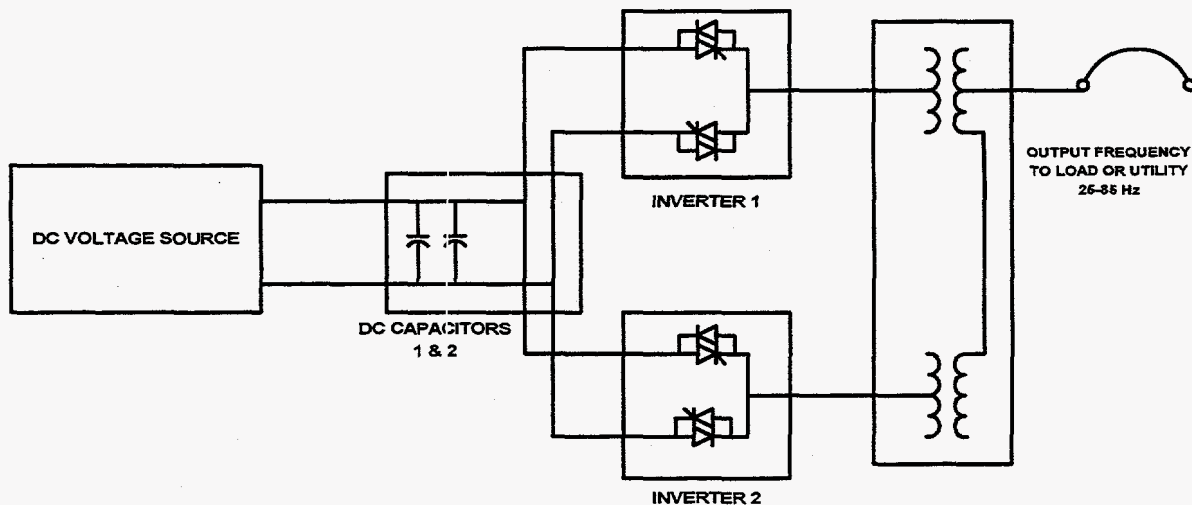

Figure 9. ABB power quality, voltage regulation, customer demand peak reduction, and area control/frequency regulation design.

This design uses two six-pulse, step-wave inverters (see Appendix B) coupled with two delta (Δ) and wye (Y) transformers to provide twelve-pulse operation at the output. This method is also known as step-wave technology. All applications mentioned use GTO technology rated at 1700 V and 1800 A with switching frequencies at 300 Hz.* The 1-MW

State-of-the-art PCS Configurations

and 10-MW systems for power quality have an output rating of 480 V and 12.5 kV, three-phase respectively. Information on the 1-MVA system for voltage regulation was not provided. The 1-MW system for customer demand peak reduction can accommodate 480-V to 12-kV operation. The 10-MW system for area control/frequency regulation applications can accommodate 12-kV to 34.5-kV outputs. The power quality application uses SMES for energy storage. The systems used for voltage regulation could use SMES and both the customer demand peak reduction and area control/frequency regulation applications could use batteries for energy storage. ABB representatives also speculated on how they would connect their PCS to the utility grid for voltage regulation, peak reduction, and area control/frequency regulation applications should such a need arise.

***Note:** As of 1998 ABB Industrial Systems has moved to IGBT- and IGCT-based technology in their PCSs.

Abacus Controls Concept

Abacus Controls' current product line includes single- and three-phase frequency converters, inverters, and UPSs. Their family of products ranges from 500 VA to 150 kVA, 45 Hz to 450 Hz for use in both commercial and military applications. Abacus proposed the TRIMODE™ power processor for hybrid renewable energy applications in the range of 5 kW, 30 kW, and 150 kW. The design used for these systems is shown in Figure 10.

The TRIMODE™ power processor uses IGBT devices with a PWM switching strategy. It operates in bimodal state for charging and discharging the battery. The TRIMODE™ works in concert with renewable sources and with AC diesel generators. The TRIMODE™ includes a DC-to-DC max power tracker, a power processing controller for a hybrid system that includes an industrial battery, an inverter battery charger, diesel engine generator, and a ground fault detector. The max power tracker converts power from the PV array to the DC bus of the TRIMODE™ power processor. Its main function is to operate the PV array at its maximum power point whenever the battery can take the power and to operate as a constant-voltage DC power supply at the battery float voltage whenever the battery is fully charged. The TRIMODE™ power processing controller optimizes the use of PV energy and minimizes the consumption of diesel fuel by managing when the diesel generator will supply the AC grid and when the battery or PV array will supply the AC grid. The ground fault detector senses a ground through the normal array grounding resistor. If the current exceeds a predetermined level, the array is short circuited and the fault is annunciated.

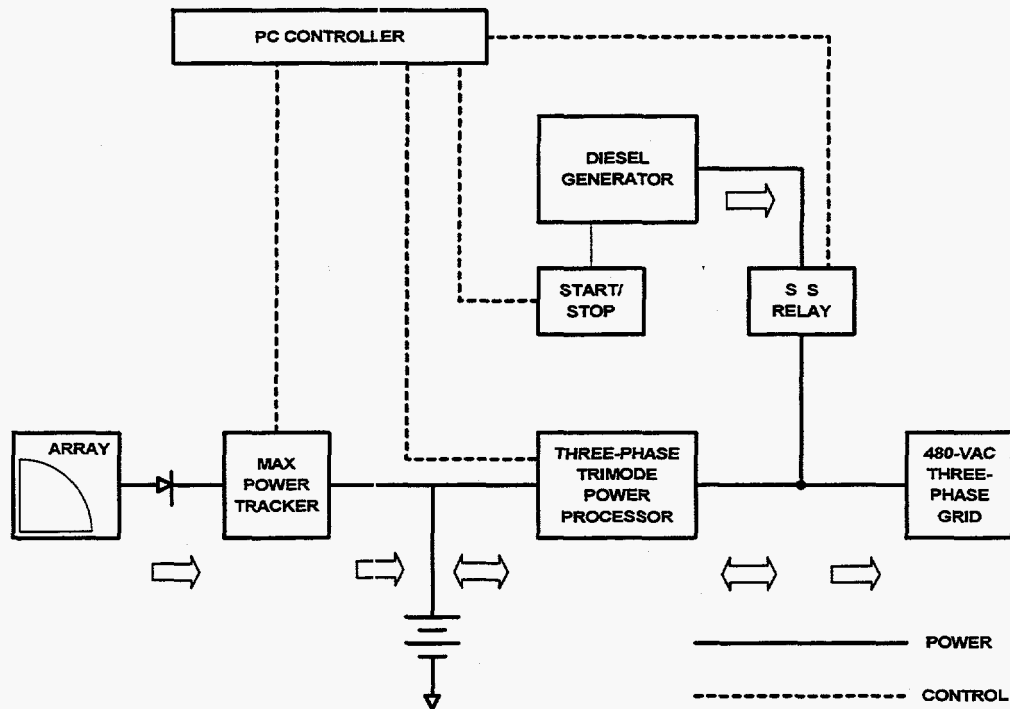

Figure 10. Abacus Controls, Inc. TRIMODE power processor hybrid topology.

Advanced Energy Systems Concept

Advanced Energy Systems specializes in hybrid inverter systems for remote applications, grid/diesel inverters, and utility-interactive micro-inverters for grid-connected applications. Some remote applications include providing electricity to communities, telecommunication sites, homes, ecotourist resorts, and other commercial enterprises. Advanced Energy Systems proposed the 5-kW, 30-kW, and 60-kW hybrid inverter units. The configuration for these hybrid inverters is shown in Figure 11.

This configuration has three operating modes:

- **Standby mode**—The engine generator is off-line and battery and renewable energy sources are operating through the inverter.
- **Battery-charge mode**—The engine generator is supplying the load, the bidirectional inverter is charging the battery with excess diesel capacity.
- **Parallel-boost mode**—The diesel generator is operating at optimal loading with the inverter supplementing the load. The inverter is bidirectional for inverter and battery charger operation.

The inverter used in the hybrid systems uses pulse-width modulation (PWM) switching strategies at 16-20 kHz operation. Single IGBT switches rated at 600 V and 200 A are used for the 5-kW units, and 600 V and 400 A for the 30- and 60-kW systems. The 5-kW unit has a single-phase output voltage of 240 VAC and both the 30-kW and 60-kW units have three-phase outputs of 240 VAC.

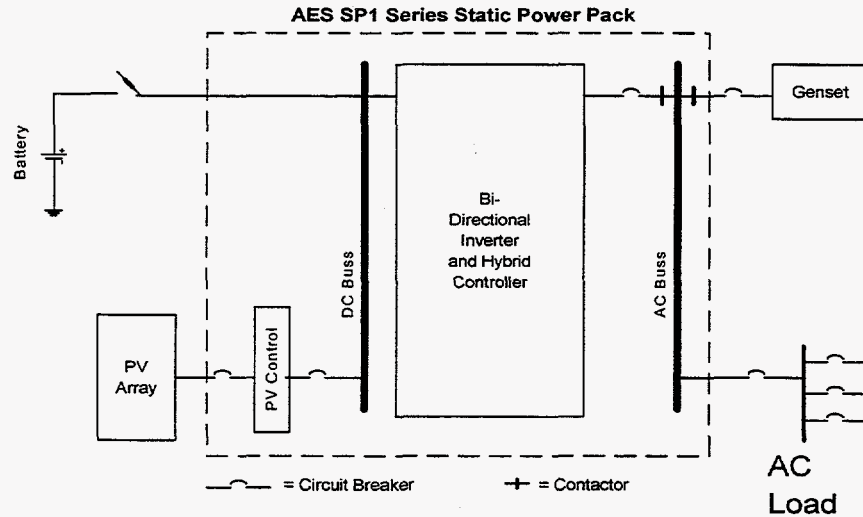

Figure 11. Advanced Energy Systems hybrid inverter design.

Exide Electronics Concept

Exide Electronics' current product line consists of single- and three-phase UPS systems that range from 650 VA to 4 MVA with input and output voltages 120 to 600 V. Exide discussed 500-kVA, 1-MVA, and 3-MVA units and the design associated with all three of these units is shown in Figure 12.

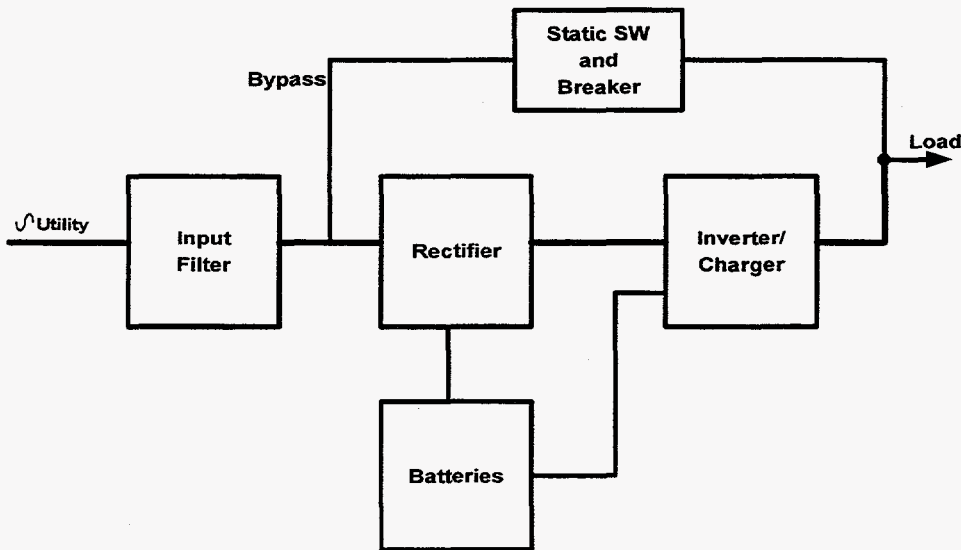

Figure 12. Exide Electronics on-line UPS design.

Figure 12 is known by the UPS community as an "on-line" technology. Other names include double-conversion or series-connected design. The on-line UPS is said to protect against all types of power problems including power surges, spikes, sags, noise, power failure, brownout, etc., and continuously uses the inverter to create 100% new, clean, regulated AC power for the protected load. Brownouts, spikes, and surges are isolated from the protected equipment by the on-line, double-conversion design. A bypass is required for servicing the

UPS system. The bypass also allows the protected load to be transferred to an alternate energy source if the UPS fails.

The 500-kVA unit presented by Exide uses PWM for its switching strategy, IGBT switches, and operates at 5-6 kHz. The 1-MVA units use SCR-based, twelve-pulse step-wave technology operating at 120 Hz. The 3-MVA rated system consists of three 1-MVA modules connected in parallel. A fourth 1-MVA unit can also be connected if the customer requires some redundancy for the system.

Liebert Corporation Concept

Liebert Corporation's product line consists of uninterruptible power supplies (UPSs) used to protect computer and telecommunications networks. The type of UPS equipment used depends on factors such as load size, criticality of applications, the proximity of the equipment being protected, and the nature of the power problems. Liebert proposed a facility-wide protection scheme for 1-MVA and 4-MVA UPSs. Facility-wide protection refers to a UPS application that supplies power to the entire facility to protect a large number of workstations and networks. The design proposed for the 1-MVA and 4-MVA UPSs is shown in Figure 13.

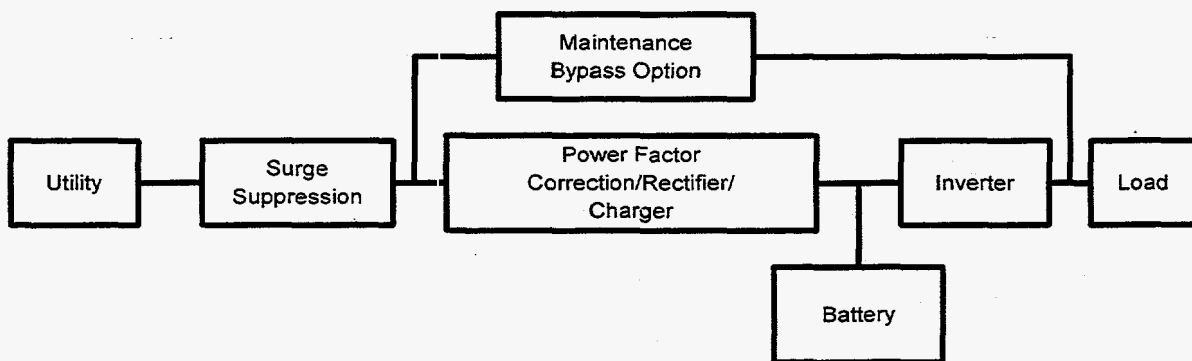

Figure 13. Liebert Corporation power quality design.

Figure 13 is an "on-line" system that provides for the highest level of network power protection. Protection is provided from many types of power disturbances including sags, outages, surges, spikes, noise, waveform distortion, and frequency variation. Conditioned power comes from the UPS continuously. The 1-MVA configuration consists of a single 1-MVA UPS unit. The 4-MVA configuration consists of four 1-MVA units connected in parallel to achieve protection rated at 4 MVA. Both the 1-MVA and 4-MVA UPSs use step-wave PWM, SCR-based technology that operates at a switching frequency of less than 1 kHz. Both have a three-phase input and output voltage of 480 V. A built-in maintenance bypass circuit allows the load to be supplied by utility power while the UPS is being serviced.

Omnion Power Engineering Concept

DOE through the ESSP issued a contract to Omnion Power Engineering Corporation to design and deliver a prototype aimed at testing battery energy storage for commercial applications by protecting utility customers from the detrimental effects of voltage

State-of-the-art PCS Configurations

disturbances that affect power-sensitive electronic equipment. Work initiated by Omnion Power Engineering to refine and enhance system designs for this project led to the formation of a strategic partnership with key suppliers under a new corporate identity known as AC Battery Corporation. AC Battery Corporation initiated development of a modular, transportable battery energy storage system, with Omnion Power Engineering Corporation supplying key power conversion technology and acting as a primary component and subsystem supplier. Under this contract, two battery energy storage systems were developed—the PQ2000 and the PM250.

The PQ2000 is a power quality device that consists of eight 250-kW modules connected in parallel to make a nominal 15-second, 2-MW battery energy storage system. Each module contains 48 batteries and a power conversion system. The purpose of the PQ2000 is to eliminate the harmful effects of voltage sags, swells, and short-term outages that may interrupt electronically sensitive manufacturing processes, data processing centers, or other critical operations. The PQ2000 consists of three main components—a system container with up to eight 250-kVA battery modules and a system controller; a 2-MVA static isolation switch and associated switchgear; and a 208/480-V isolation transformer. The controller is microprocessor based. The PCS uses IGBT and hysteresis current regulator technology (see Appendix B) for switching and power conversion. The PQ2000 block diagram is shown in Figure 14.

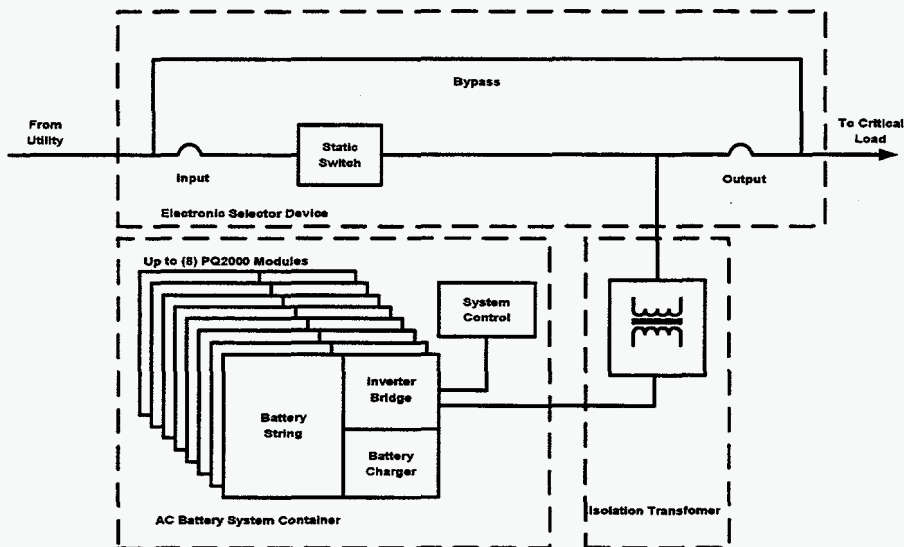

Figure 14. AC Battery PQ2000 configuration.

The PM250 is a fully-integrated, prepackaged, factory-assembled battery energy storage system. Once the system goes online, it can perform multiple functions, including peak shaving, load leveling, and voltage and frequency regulation. It consists of a 250-kW, 167-kWh battery energy storage system. The PM250 comprises eight modules, each containing 48 12-V batteries and a power conversion system. Multiple container installations can be configured in 250-kW increments up to 10 MW.

Like the PQ2000, the PM250 has microprocessor-based control and the PCS uses IGBT and hysteresis current regulator technology for switching and power conversion. Its standard

operating voltage is three-phase, 480 VAC. The topological block diagram is shown in Figure 15.

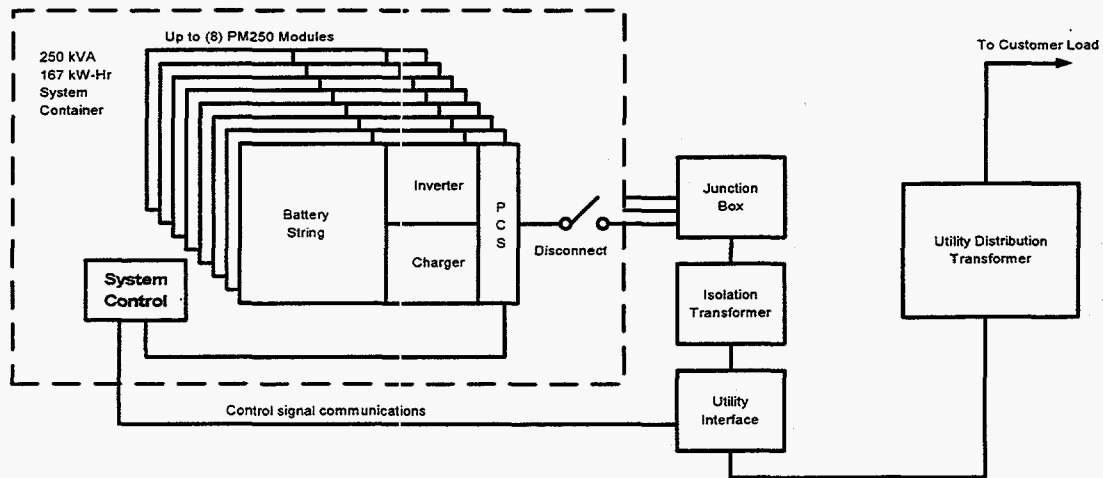

Figure 15. AC Battery PM250 configuration.

Orion Energy Concept

Orion Energy's current product line is the APEX series, which consists of packaged power systems designed to provide 6 to 24 kWh per day of AC or DC power for off-grid applications. The basic skid-mounted package includes the battery, control and power electronics, a diesel generator, and a fuel tank. It also includes a connection for multiple PV arrays, which can be mounted nearby. Orion presented the APEX 2-kW hybrid, which uses PWM switching strategies and has 12 kWh of storage. The 2-kW APEX system is shown in Figure 16. Figure 16 is also known as a "series" or "DC" hybrid system because the generator is located on the DC side of the inverter.

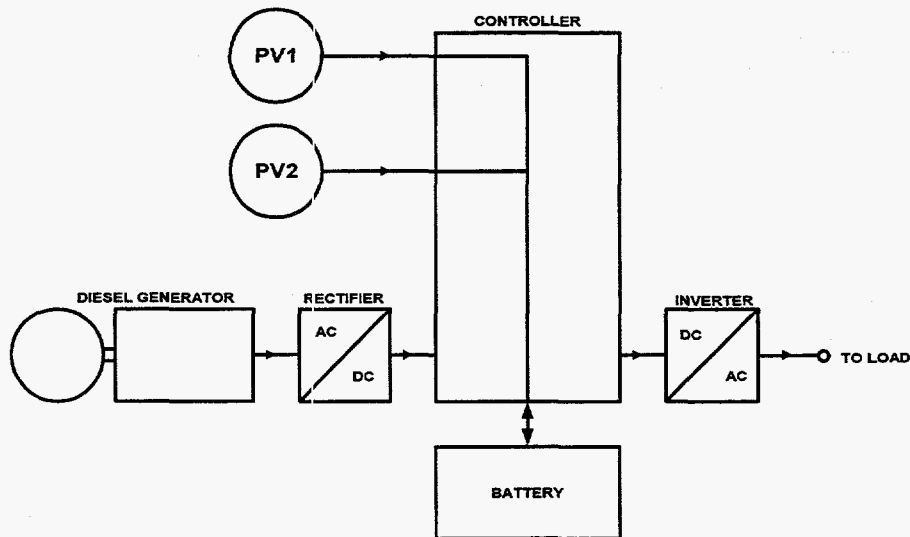

Figure 16. Orion Energy's series hybrid system.

State-of-the-art PCS Configurations

The load is supplied primarily from the battery, which is recharged by the PV array when energy is available. When the battery state of charge falls below a preset level, the generator is started and provides rapid recharge of the battery. Typical operation is with a 50% solar contribution and the generator running about twice a week for about six hours at a time.

Soft Switching Technologies Concept

Soft Switching Technologies' product line is based on a line of soft-switching resonant DC link (RDCL) inverter modules. This zero-voltage switching, three-phase inverter product line is currently rated up to 200 kVA in single modules, and the devices may be connected in parallel to achieve higher ratings. The link frequency of the RDCL is approximately 70 kHz and depends on control and application requirements. The RDCL is known to have lower EMI, higher efficiency, minimum acoustical noise, and higher-control bandwidth properties than conventional PWM-based inverters. The standard RDCL inverter module has a nominal 480-VAC or 650-VDC input and 460-VAC, three-phase outputs. The units are available up to 250-A root mean square (rms), which represents a continuous rating of 200 kVA. Other products include switch mode DC-to-DC converters and DC power supplies with output current ratings of 50 to 1000 A and output voltage ratings of 5 to 54 VDC. Some RDCL applications include frequency converters (up to 180 kVA), automatic voltage regulators (available at power ratings from 100 to 750 kVA), active filters, IEEE 519-compatible power converter systems, and UPS systems for industrial processes.

Trace Technologies Concept

Trace Technologies' current product line consists of grid-independent hybrid power processing systems with ratings of 30 kVA to 250 kVA. Trace provides units and subassemblies to original equipment manufacturers and value-added resellers. Grid-connected applications in power quality, voltage regulation, customer demand peak reduction, and area control/frequency regulation were discussed. Grid-independent applications with ratings of 120 kWh (for small villages) and 250 kWh (for large villages) were also discussed.

Trace discussed system designs rated at 1.3 MVA for voltage sag protection, a power quality application. Figure 17 shows the configuration used for this application. This configuration consists of six 216-kVA PCS units connected in parallel to achieve a 1.3-MVA design.

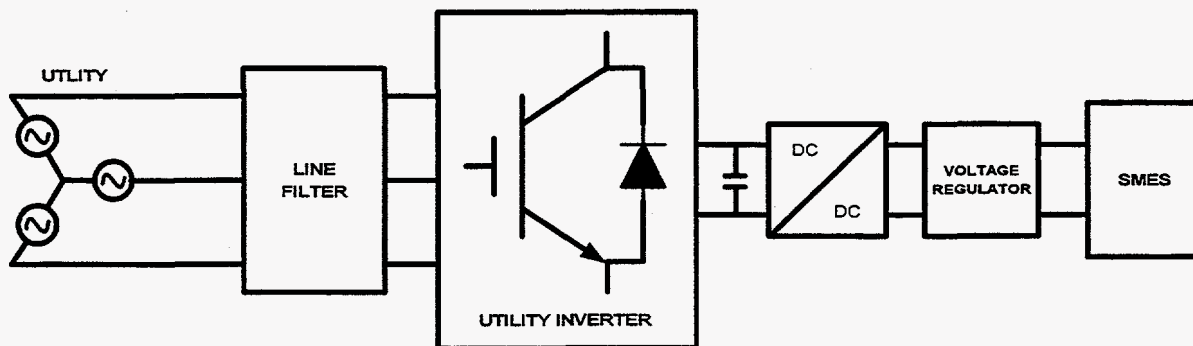

Figure 17. Trace 1.3-MVA SMES voltage sag protection design.

For voltage regulation and customer demand peak reduction applications, Trace presented a 50-kVA unit as shown in Figure 18. This configuration, also known as double conversion, was proposed by Trace for voltage regulation applications.

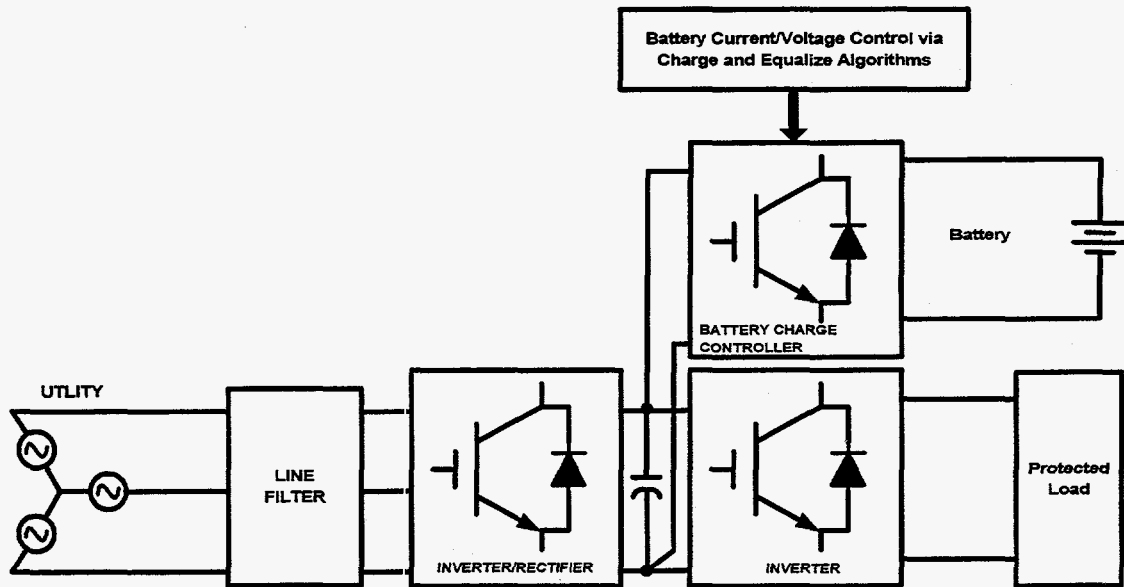

Figure 18. Trace 50-kVA voltage regulation and customer demand peak reduction design (proposed).

For the area control/frequency regulation application Trace proposed the 10-MVA configuration shown in Figure 19. This design consists of twenty 500-kW modules connected in parallel to increase the rating up to 10 MVA.

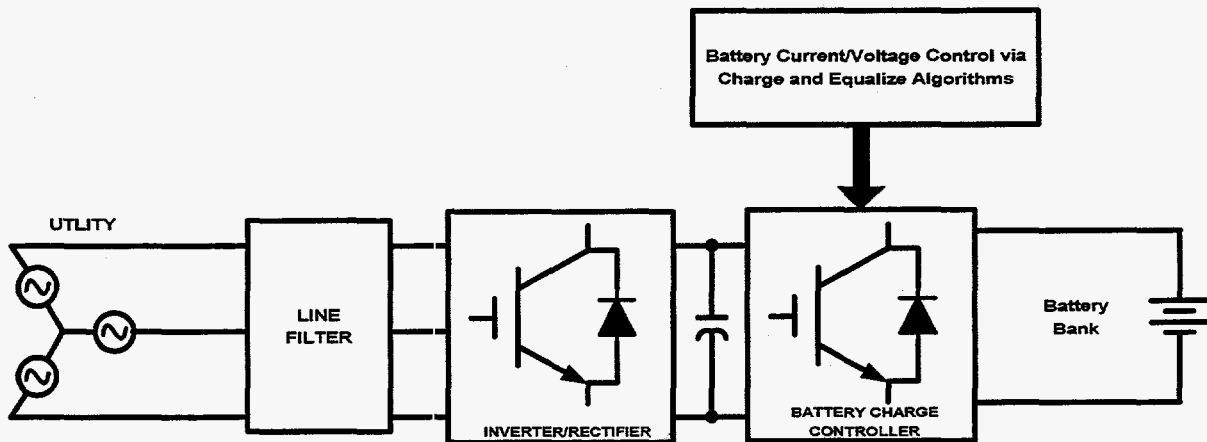

Figure 19. Trace 10-MVA area control/frequency regulation design (proposed).

For off-grid hybrid units, Trace uses the configuration shown in Figure 20, which is rated at 30 kVA or 250 kVA. This design uses batteries, PV, and a diesel generator to deliver power to the customer load.

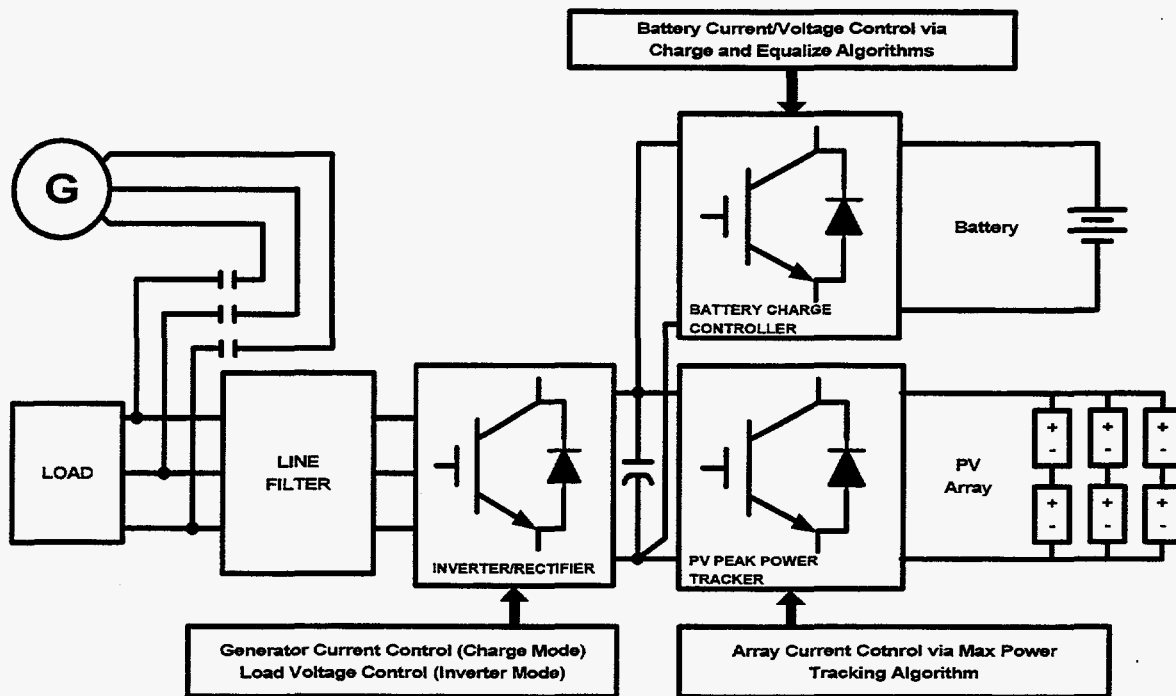

Figure 20. Trace 30-kVA or 250-kVA off-grid hybrid design.

Westinghouse Electric Concept

Westinghouse Electric develops and supplies power conversion systems for a variety of applications and industries. Westinghouse has currently two classes of equipment: the Flexible AC Transmission System (FACTS) and Custom Power products. FACTS and Custom Power equipment have been supplied at ratings of 40 MVA through 320 MVA, and 2 MVA through 6 MVA respectively.

A joint partnership between the Electric Power Research Institute (EPRI), utilities, and Westinghouse Electric Corporation, that addresses power stability issues developed the FACTS concept to improve power control, capacity, and security of transmission lines. Central to FACTS are advanced power electronics to control the flow of current over the transmission lines.

Westinghouse's line of Custom Power products, created in cooperation with EPRI, include the dynamic voltage restorer (DVR), distribution static compensator (DSTATCOM), solid-state breaker, and solid-state transfer switch. Of the available product lines, the DVR (for power quality applications) and the DSTATCOM (for voltage regulation applications) were discussed in detail.

Figure 21 shows the DVR block diagram for a power quality application. The DVR is designed to restore the quality of electric energy delivered to the end user when the voltage on the source side is out of specification for load-sensitive equipment. When tied to the utility via a series injection transformer, the DVR is designed to eliminate voltage sags, swells, and transients; regulate voltage within acceptable tolerances; and compensate for harmonic line voltage. Current DVRs have a size range of 2 to 10 MVA in 2-MVA modules and 4160 V to 34.5 kV.

Westinghouse relies on a modular approach consisting of 2-MVA DVR units, which use PWM switching strategies, eight IGBT switches in series (each rated at 1800 V and 400 A), and an output voltage at the secondary of the series injection transformer of 4160 V. They currently use capacitors for energy storage.

Figure 22 shows the DSTATCOM block diagram for the voltage regulation application. The DSTATCOM is used to protect the distribution system from “polluting” loads, surges, or harmonics caused by other users on the system. The shunt-connected DSTATCOM injects a current at the proper phase angle with system voltage to provide voltage support and regulation of VAR flow. It is said to replace the conventional switched inductors and capacitors for the same application. The DSTATCOM can be coupled with a solid-state breaker and energy storage. When a source disturbance occurs, the solid-state breaker isolates the DSTATCOM and connected load, and the DSTATCOM supports the entire load from its energy storage subsystem. Current sizes range up to 20 MVA (one to ten 2-MVA modules), with a maximum power insertion of ± 2 MVA per module, and an application voltage range of 4160 V to 69 kV.

Westinghouse uses the 2-MVA DSTATCOM for voltage regulation. It uses PWM switching strategies, eight IGBT devices connected in series at 1200 V and 400 A, with a 4160-V output. The number of devices necessary (in this case eight) depends on the maximum voltage expected at the DC link and includes a safety factor to ensure reliable operation. Consequently, eight 1200-V switches (which total 9600 volts) provide a generous margin for its 4160-V output.

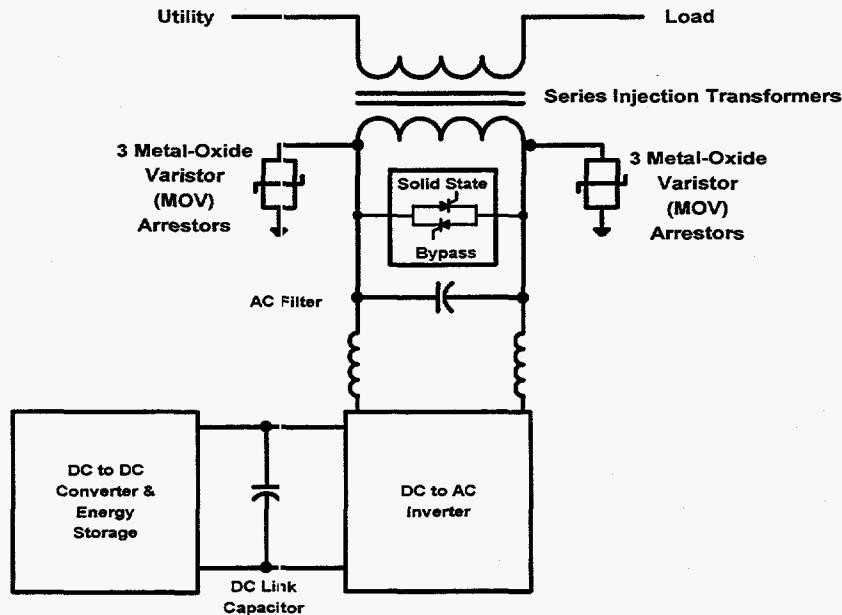

Figure 21. Westinghouse Electric DVR.

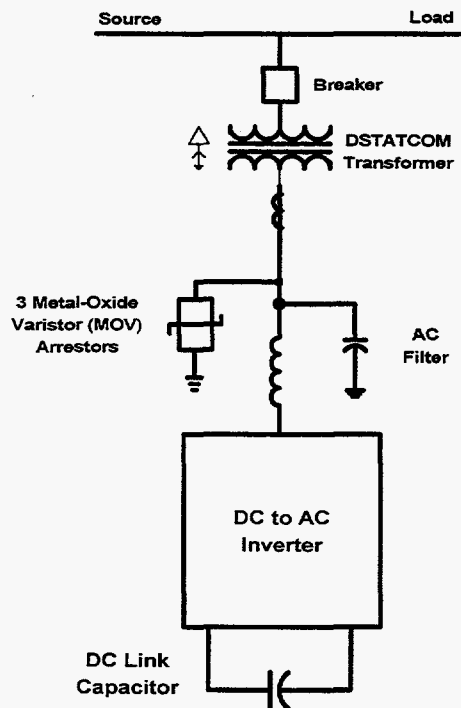

Figure 22. Westinghouse Electric DSTATCOM.

Northern Power Systems Concept

Northern Power Systems (formerly The New World Power Technology Company) specializes in remote power generation. The company designs prepackaged hybrid power systems that supply electricity to off-grid villages and communities, industrial facilities, resorts, and other applications requiring autonomous power supplies. These hybrid systems are “rotary” based rather than “static” based. Rotary-based systems (also known as rotary conversion systems) use rotating machines to convert one form of power to another. A simplified block diagram of a rotary conversion system that uses wind turbines as the energy source is shown in Figure 23.

The rotary converter modules can be made to couple the available renewable energy sources (wind, solar, hydro) with an integrated engine generator/converter unit and short-term battery storage to provide continuous power to the customer. The prepackaged power system is available in 50-kW and 100-kW units. Costs for rotary systems are not included in this report, but in general the costs for the 50- and 100-kW units (not including the diesel generator) are \$350/kW and \$250/kW, respectively.

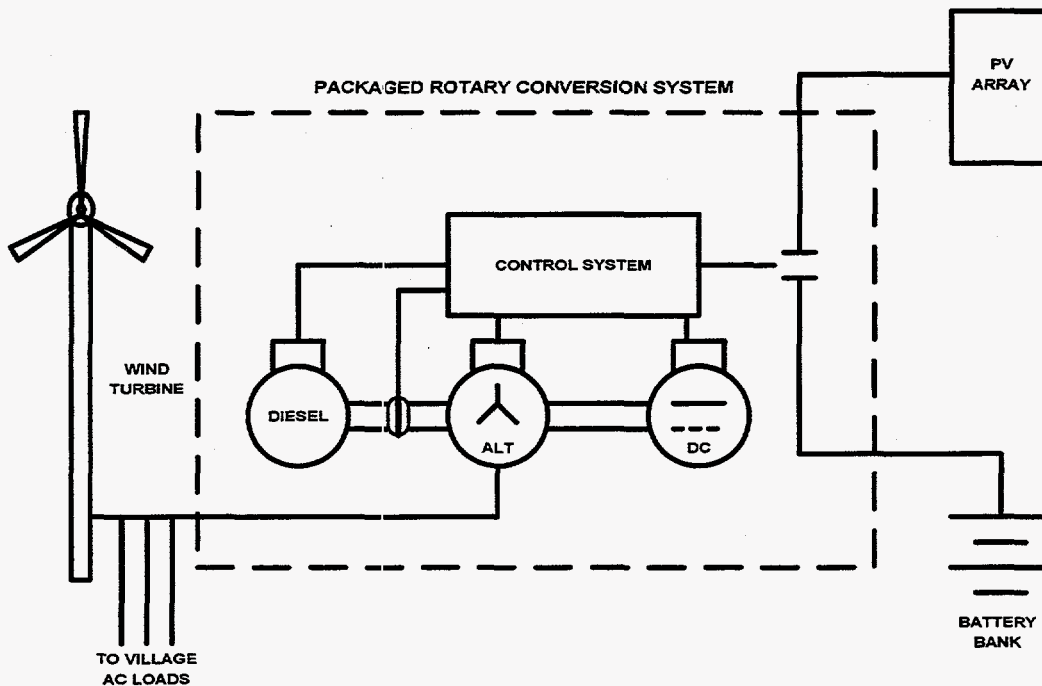

Figure 23. Northern Power Systems rotary conversion system.

Oak Ridge National Laboratory Concept

ORNL's Power Electronics Center has developed two "new generation" power converter technologies that utilize soft-switching technology and multilevel converters. Table 4 summarizes the soft-switched and multilevel converters built and tested at ORNL to date.

In general, the multilevel converter synthesizes the staircase output voltage waveform with multiple capacitor voltages, as opposed to multiple transformer couplings used in traditional step-wave inverter systems. A detailed discussion of multilevel converters can be found in Lai and Peng's "Multilevel Converters—A New Breed of Power Converters."

Three types of capacitor-voltage/synthesis-based multilevel converters were recently reviewed by ORNL: the diode-clamped converter, the flying capacitors converter, and the cascade inverter with separate DC sources. All of these converters are variants of the basic multilevel converters described in Appendix B. Some possible applications for the diode-clamped and flying capacitors converters include providing reactive power compensation, functioning as a back-to-back intertie between adjacent utility grids for unified power flow control, and use as adjustable speed drives. Some possible applications for the cascade multilevel inverter with separate DC sources include reactive power compensation, power line conditioning, series compensation, and phase shifting.

State-of-the-art PCS Configurations

Table 4. Soft-switched and Multilevel Converters Built and Tested by ORNL

Soft Switched Inverters	Power Level (kW)	Operation (Volts/Amps)	Description of Test
Single-phase resonant snubber inverter (RSI)	1	110/2	Used as an adjustable speed drive for ¼-hp fan.
Three-phase RSI	100	200/300	Drove a three-phase reactive inductor load.
	100	200/300	Drove a permanent magnet axial gap (PMAG) motor to 1000 rpm.
	100	200/300	Drove in regenerative mode to control a DC link for inserting power back on grid.
Three-phase auxiliary resonant tank (ART) inverter	10	230/30	Drove 5-hp induction motor and 50-kW PMAG motor at 13 hp.
Multilevel Inverters and Converters	Power Level (kW)	Operating (Volts/Amps)	Description of Test
Diode-clamped back-to-back voltage source converter	10	230/35	Transferred power across an interface between two different AC sources.
	10	230/35	Drove a 50-kW PMAG motor from the line with unity power factor at 10 kW.
Cascade multilevel inverter with separate DC sources	0.22	110/2	Interfaced five 30-V power supplies simulating PV modules to drive a 110-V house fan.
	10	230/3.2	Interfaced five 36-V storage batteries to drive three-phase ¾-hp induction motors at 230 V.
	10	230/3.2	Interfaced five 36-V storage batteries to drive three-phase 5-hp induction motors at 230 V.
	10	240/24	Operated a power line conditioner that provided VAR compensation and voltage regulation.

Below are two examples of multilevel inverters used in grid-connected system applications. In both figures, V_S and I_S represent the utility three-phase voltages and currents and V_C and I_C represent the multilevel three-phase output voltages and currents. L_S and L_L represent the converter's inductance. Figure 24 shows a multilevel converter connected to a utility for reactive power compensation. This multilevel structure is directly tied to the utility grid. Consequently, it does not require a step-down transformer. The polarity and the magnitude of the reactive current are controlled by the magnitude of the converter voltage, which is synthesized from the capacitor voltages. One use for reactive power compensation is to maintain supply voltages at the load if the voltage drop occurs at the utility. Reactive power compensation minimizes power transmission losses, maximize power transmission capability, and stabilize the power system.

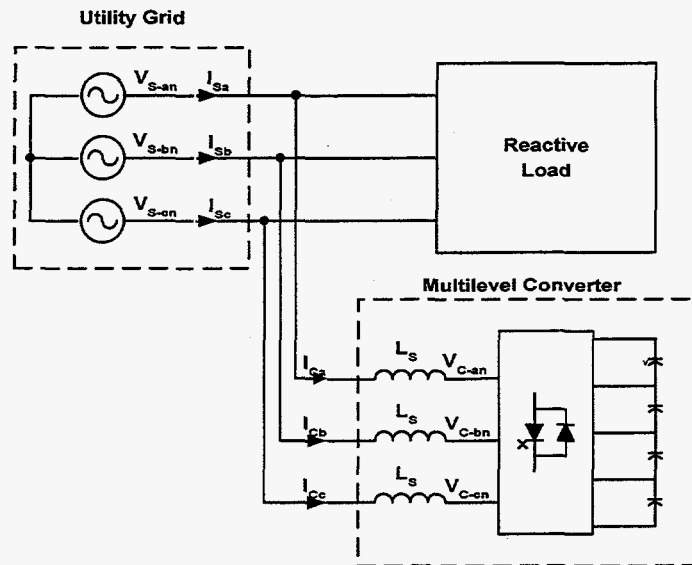

Figure 24. Multilevel converter used for reactive power (R&D).

A back-to-back intertie is a connection between two adjacent utility grids that are out of phase. The intertie can function as a frequency changer, phase shifter, or a power flow controller. A block diagram showing a back to back intertie is shown in Figure 25. The power flow between the two grids is controlled bidirectionally.

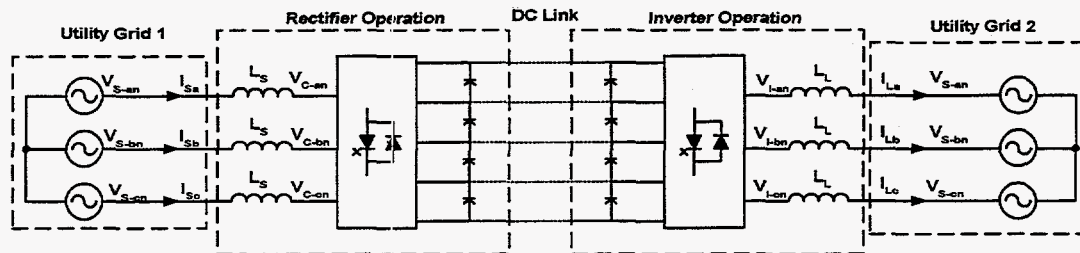

Figure 25. Multilevel converter used in a back-to-back intertie (R&D).

Power Electronics Building Block Concept

A related concept that is not a specific system configuration is the PEBB project—a federal interagency program. The project’s primary sponsor is the U.S. Navy, through the Office of Naval Research. The project also receives support from various universities and the national laboratories and participation from industry. Industry and the Department of Defense have a great interest in reducing both the cost and time required to design and produce power electronic circuits. DOE is interested in PEBB for transportation and utility applications (Hamilton).

The PEBB concept is to create a universal power processor; one that could change any type of electrical power to any desired voltage, current, and frequency output (see Figure 26). PEBB is being designed to make the necessary electrical conversion by sensing what type of electrical input source the PEBB unit is plugged into and what type of load is attached to it. Ideally, this conversion would be accomplished automatically using software internal to the

State-of-the-art PCS Configurations

PEBB unit (similar to “plug and play” computer technology). For example, one of the goals of the project is to design a PEBB converter that could be plugged into any wall outlet in the world and provide the correct type of power needed by any U.S. appliance. The vision for PEBB is to develop a single package multifunction controller that 1) replaces complex power electronic circuits with a single device, 2) reduces development and design costs for complex power circuits, and 3) simplifies development and design of large electric power systems.

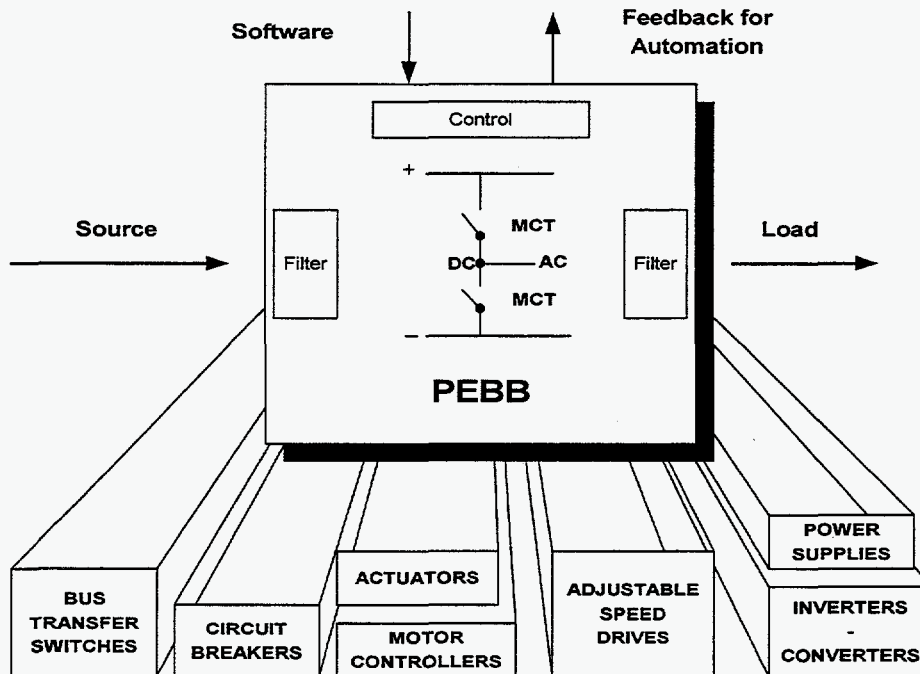

Figure 26. The PEBB concept (R&D).

The design and development of PEBB units is currently considered device-independent. This means that the PEBB unit may be based on MCT, IGBT, MOSFET, or any other type of available semiconductors and, consequently, may be designed for a wide range of voltage and current ratings. The rating would depend on the application. The PEBB concept utilizes soft-switching technologies for their circuit topologies.

The PEBB project has had a number of demonstration units built and tested. One utility-scale project is based on a contract signed with Silicon Power Corporation to produce a full-scale, 3-MW, soft-switching converter that would use MTOs as its semiconductor switches. Future applications for this unit include a 3-MVA static compensator for voltage regulation and harmonic cancellation. The unit will also include a battery interface for operation as a UPS. Other development in progress involves a 50-kW soft-switching converter for demonstrating MCT switches and a 400-kVA soft-switching converter for demonstrating MTO switches (PEBB web page).

PCS Configurations Summary

This section summarizes the static converter system configurations described in the previous section. There are many different ways of diagramming different PCS configurations but, in general, the system designs can be presented using block diagrams. Most of the state-of-the-art PCS designs discussed earlier fit in one of the following four configuration categories, which are discussed in greater detail below:

- Grid-connected parallel configuration
- Grid-connected series configuration
- Grid-independent parallel hybrid configuration
- Grid-independent series hybrid configuration

Grid-connected Parallel Configuration

Grid-connected systems using a parallel configuration have the energy storage system connected in parallel with the utility to the load. The simplified block diagram of such a system is shown in Figure 27. This simplified system configuration consists of a DC-to-AC inverter, an optional DC-to-DC/AC-to-DC converter, a controller, and a transformer. The DC-to-DC and AC-to-DC converter may be used, at additional cost, to provide charge/discharge control or to optimize operating conditions for the inverter. The DC-to-DC converter is typical of SMES- and battery-based energy storage systems. In some instances, batteries are connected directly to the DC bus without a DC-to-DC converter. A flywheel-based energy storage system would require an AC-to-DC converter because pre-conversion of the flywheel power is necessary. The transformer can either be shunt- or series-injected.

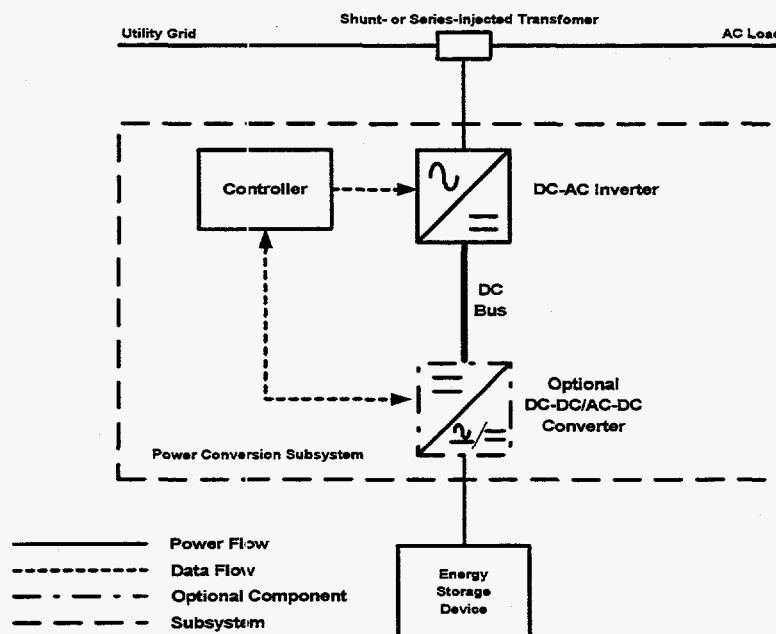

Figure 27. Grid-connected parallel configuration.

The DC-to-AC inverter (also known as the bidirectional inverter) has two modes of operation, the rectifier and inverter modes. In the rectifier mode the converter controls the voltage and the charging current by turning semiconductor switches OFF and ON. The

PCS Configurations Summary

voltage and current are adjusted to the desired charge rate for the storage system. In the inverter mode, the converter (by turning semiconductor switches OFF and ON) synthesizes AC output.

Shunt- and Series-injection Transformers

Examples of shunt- and series-injection transformers are shown in Figure 28. The system integrator generally makes the determination of which transformer to use based on the application; certain tradeoffs in efficiency, reliability, and rate of response between the two types of transformers; and field experience.

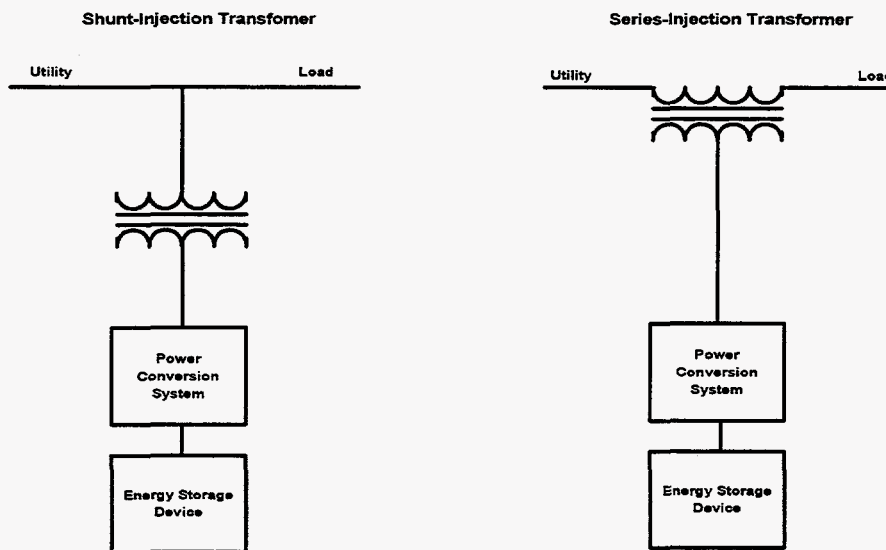

Figure 28. Example of a shunt-injection and a series-injection transformer.

A grid-connected system using a parallel configuration and a shunt-injection transformer can exchange both real and reactive power with the utility and the load by varying the amplitude and phase angle of the inverter output with respect to the utility voltage. The result is a current flow through the transformer from the energy storage device and the PCS to the utility. This current flow enables the PCS to control the utility voltage, for example in voltage regulation applications. Generally, the PCS and the load can be disconnected from the utility using a solid-state breaker in the event of a utility-side fault or interruption. The PCS and the energy storage device supply full-rated real power at the load. When the utility voltage is restored, the solid-state breaker restores the connection between the utility and the load and the energy storage device is recharged via the PCS or via a lower-rated PCS that is also tied to the utility.

A grid-connected system using a parallel configuration and a series-injection transformer can generate or absorb independently controllable real and reactive power at the PCS output terminals. The PCS injects a set of AC output voltages in series and synchronized with the utility voltage. The amplitude and phase of the PCS output voltages are variable, thus allowing the exchange of real and reactive power between the PCS and the utility. The reactive power exchange is internally generated by the PCS without any passive AC components, such as inductors or capacitors. The real power exchange must be achieved by an external energy storage device. For example, in voltage sag protection, the PCS injects

voltages to restore the quality of the voltage at the load when the utility voltage sags below a specified level. When the utility voltage is restored, the energy storage device is recharged using utility power via the PCS. In some cases, the recharge is achieved by a smaller-rated PCS that is also tied to the utility (Woodley, et al.).

Grid-connected Series Configuration

Systems using the grid-connected series configuration are generally on-line or double-conversion systems. On-line refers to a PCS that is continually used; in other words, it is always “on line” to the load. Double-conversion refers to systems that convert power twice, once from AC to DC and then from DC to AC. The on-line system is shown in Figure 29 and consists of a rectifier, an inverter, an optional DC-to-DC or AC-to-DC converter, a controller, and a bypass switch. It may or may not have an input filter or surge suppression on the utility side of the system; these decisions are usually driven by the customer or the manufacturer.

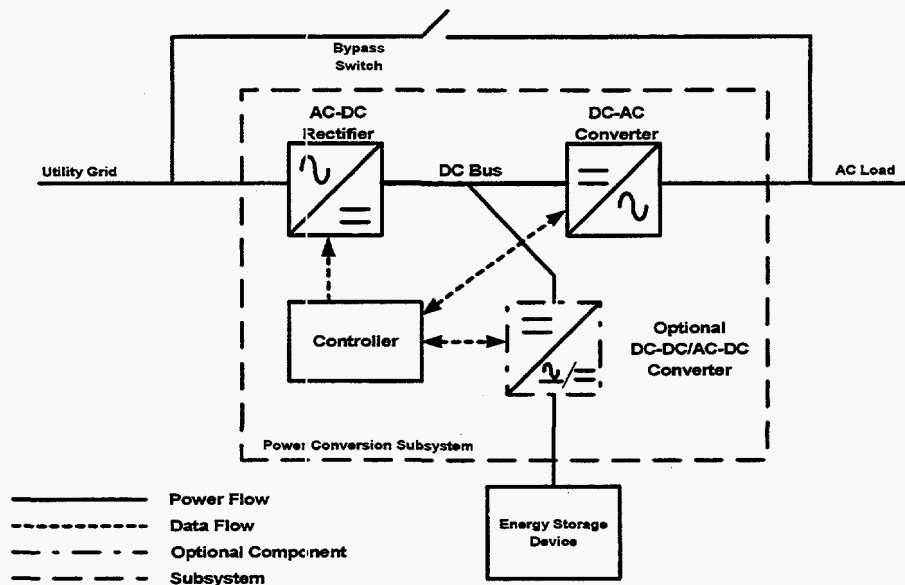

Figure 29. Grid-connected series configuration.

For the system shown in Figure 29, the rectifier converts utility AC power to DC power. The inverter converts the DC-bus power back to utility AC for use at the load. The DC-to-DC converter is used for charge/discharge control and to optimize operating conditions for the inverter. The AC-to-DC converter is used to convert AC power to DC power to be used by the DC bus. This is typical of flywheel-based energy storage systems. The controller controls the flow of energy from the utility to the load, from the utility to the energy storage device, and from the energy storage device to the AC load. The bypass switch is typically used for isolating the PCS during maintenance or for providing bypass power in the event of a PCS failure. The bypass switch is typically a static switch or a solid-state device. For added protection, an input filter or surge suppressor is used on the utility side of the PCS. The input filter reduces harmonic currents that could feed back into the utility, which could potentially cause computers to malfunction, transformers and motors to overheat, and circuit breakers to trip. The surge suppressor reduces power surges or voltage increases in one or more cycles, high voltage spikes, and switching transients. The reduction is achieved by clipping high

PCS Configurations Summary

voltage spikes to safe and tolerable levels. Power surges and spikes may be caused by heavy electrical equipment being turned off on the customer side, or by load shedding, switching operation, arcing faults, or lightning strikes on the utility side.

Grid-independent Parallel and Series Hybrid Configurations

Hybrid systems consist of more than one source of electrical energy and are configured so that the AC load can be served directly or indirectly by any or all of the system's energy sources. Most hybrid systems today consist of the following energy sources: an engine generator, a renewable (PV or wind), and a battery. Generally hybrid systems are used to reduce the engine generator's run time and, consequently, fuel consumption. Hybrid systems are also used to optimize generator use for loads that are periodically very large and highly variable by properly managing the renewable and storage (battery) resources (Bower).

The primary distinction between systems using parallel and series hybrid configurations is how the engine generator is tied into the overall system. In a parallel hybrid configuration the engine generator is tied directly to the AC load. In a series hybrid configuration the engine generator is tied to the DC bus of the PCS via a rectifier (AC-to-DC converter). Major components in the PCS for the parallel hybrid configuration are a DC-to-AC inverter, an optional DC-to-DC or AC-to-DC converter, and the controller (see Figure 30).

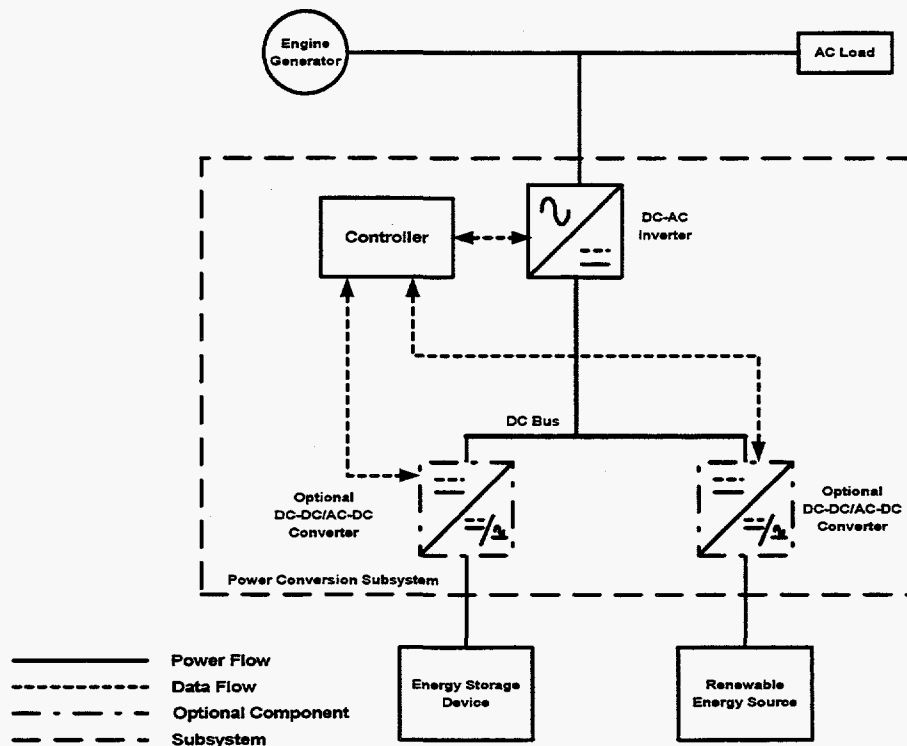

Figure 30. Grid-independent parallel hybrid configuration.

This configuration has three different operating modes—stand-alone, battery-charge, and parallel-boost mode. In the stand-alone mode, the engine generator is off-line and the renewable energy sources and batteries operate through the inverter. In this mode, the inverter converts DC power to AC power to the load. In the battery-charge mode, the engine generator supplies the load and excess power from the engine generator charges the battery.

In this mode, the inverter functions as a rectifier to convert AC power to DC power. In the parallel-boost mode, the engine generator is operating at optimal load with the renewable energy source and the energy storage device supplying supplemental power to the load. The inverter converts DC power to AC power in this mode. Some manufacturers use the bidirectional inverter as a battery charger or use a separate charge controller. The charge controller is typically a DC-to-DC converter that controls the charge rate to the battery bank.

In the series hybrid configuration (Figure 31), the load is supplied primarily from the battery via the DC-to-AC inverter; the battery is recharged, when energy is available, by the renewable energy source via the optional DC-to-DC converter (for PV arrays) or AC-to-DC converter (for wind generators). The DC-to-DC converter used with PV arrays is also called the max power tracker or PV controller. When the battery state of charge falls below the preset level, the generator is started and provides rapid recharge of the battery. The recharge of the battery is achieved through an AC-to-DC converter (rectifier).

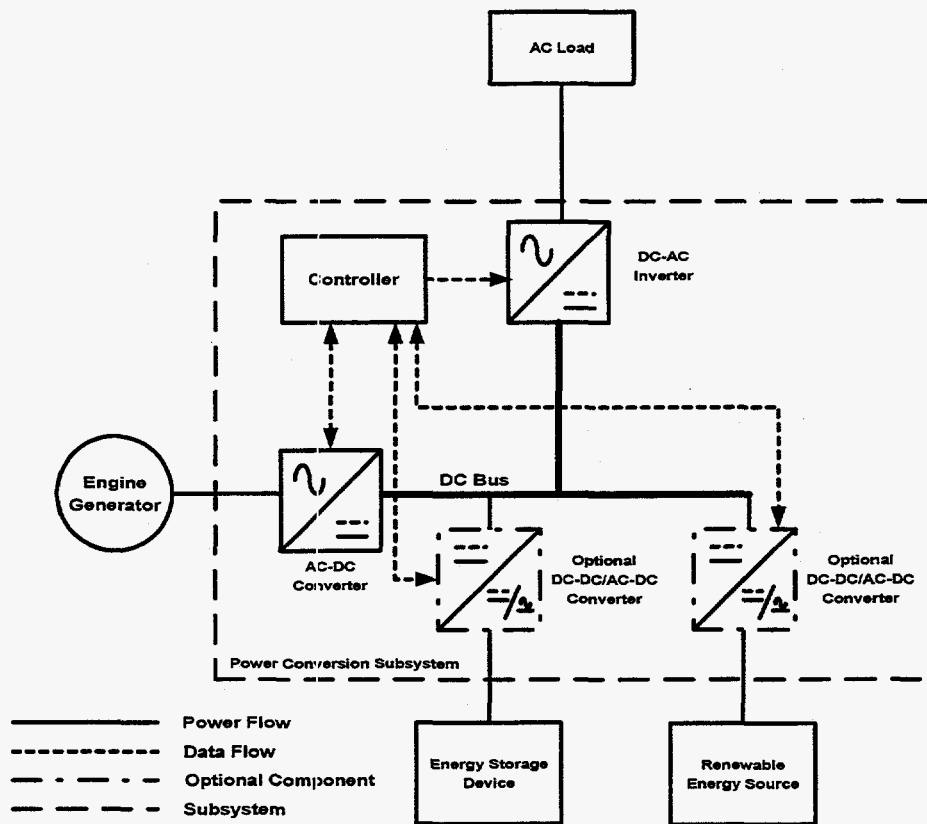

Figure 31. Grid-independent series hybrid configuration.

PCS Configurations Summary

Comparison and Use of PCS Configurations

Comparisons of the grid-connected and grid-independent configurations are provided in Table 5 and Table 6.

Table 5. Grid-connected Systems Parallel/Series Configuration Comparison

Parallel Configuration	Series Configuration
PCS can be de-rated (lower)	PCS is continuously rated (higher)
Minimal switching delay	No switching delay
System failure doesn't affect the load	System failure requires a bypass and possible interrupt

Table 6. Grid-independent Systems Parallel/Series Configuration Comparison

Parallel Configuration	Series Configuration
Complex AC switching	No AC switching
Possible power disturbance if engine generator is activated	No power disturbance if engine generator is activated
Bidirectional inverter	Unidirectional inverter
More availability—inverter failure does not result in system failure	Less availability—if the inverter fails, the system fails
Complex and custom supervisory controller	Simpler supervisory controller

Table 7 summarizes the design configurations used for energy storage applications.

- **Configuration A**—Grid-connected parallel configuration
- **Configuration B**—Grid-connected series configuration (on-line or double conversion systems)
- **Configuration C**—Grid-independent parallel hybrid configuration
- **Configuration D**—Grid-independent series hybrid configuration

Table 7. Summary of Design Configurations Used by Companies Interviewed

Manufacturer	PQ	VR	CDPR	AC/FR	Res.	SV	LV
ABB	A	A	A	A	-	-	-
Abacus	-	-	-	-	C	C	C
Advanced Energy Systems	-	-	-	-	C	C	C
Exide Electronics	B	-	-	-	-	-	-
Liebert	B	-	-	-	-	-	-
Omnion	A	-	-	-	-	-	-
Orion	-	-	-	-	D	-	-
Trace	A	B	B	A	-	C	C
Westinghouse	A	A	-	-	-	-	-

PCS Efficiency

PCS efficiency (the ratio of AC power supplied to DC power drawn in the inverter mode or DC power supplied to AC power drawn in the charging mode) can be an important consideration in ESS applications. Low PCS efficiency indicates that the energy storage device rating must be increased, which in turn increases the initial cost of the energy storage system. In applications where the PCS operates continuously, for example a series-connected UPS, low efficiency implies a recurring cost component that corresponds to energy loss. However, in ESS applications such as power quality and voltage regulation, where the PCS operates at full load for only a short period of the time, a low efficiency PCS has minimal impact on the PCS operating cost. It should be noted, however, that for power quality and voltage regulation applications, device loss considerations that affect the cooling requirements remain an issue.

PCS losses can be divided as follows:

- Semiconductor device ON-state loss
- Switching loss
- Copper loss in transformers and inductors
- Core loss in magnetics

Efficiencies for the commercial or proposed PCSs described in this report are provided in Table 8. In this table, some manufacturers specified efficiency from the DC bus to the AC output of the PCS, while others included the AC transformer in the specified efficiency. For double-conversion systems or series-connected UPSs, some manufactures defined efficiency from the AC input power to the AC output power. From the standpoint of energy storage, the efficiency from the DC to the AC appears to be most important. All of the efficiencies listed exceed 90% at full load; the soft-switched converters provide a small improvement compared to hard-switched converters.

For silicon-based minority carrier devices, it is virtually impossible to reduce the ON-state voltage drop in a device. Future devices such as silicon carbide, gallium nitride, aluminum nitride, or diamond-based materials might have smaller ON-state voltage drops or ON-state resistance, which would increase the overall system efficiency. Switching losses can be eliminated or reduced by soft-switching; however, the objective of soft-switching is to allow higher switching rates. Core and copper loss can be reduced, to an extent by, for example, using copper conductors. Nonetheless, it is not expected that PCS efficiency will increase substantially in the near future. The efficiencies shown in Table 8 also suggest that efficiency may not be a near-term concern for the target applications described by this report.

PCS Configurations Summary

Table 8. PCS Efficiencies

Company	Application	Rating	Device	Efficiency
ABB	PQ	1 MVA	GTO	Full load – 98% to 98.5% 50% load – 97%
Abacus	Hybrid, All	5 kVA to 150 kVA	IGBT	Full load – 92%
Advanced Energy Systems	Hybrid, SV	30 kW	IGBT	Full load – 92% 50% load – 93%
Advanced Energy Systems	Hybrid, LV	60 kW	IGBT	Full load – 92% 50% load – 93%
Exide	UPS	1 MVA	SCR	Full load – 93% 50% load – 91%
Exide	UPS	500 kVA	IGBT	Full load – 95% to 97%
Liebert	UPS	1 MVA	SCR	Full load – 93%
Liebert	UPS	500 kVA	IGBT	Full load – 94% 75% load – 94% 50% load – 93%
Orion	Hybrid, R/TC	2 kW	IGBT	Full load 90%, 40% load 85%
Soft Switching Technologies	-	100 kW	IGBT	Full load – 97.7% 50% load 97.5% 10% load 93%
Trace	PQ	216 kVA	IGBT	Full load – 95% to 97%
Westinghouse	PQ	2 MVA	IGBT	Standby mode - 1% to 3% loss Active mode – losses not given
Westinghouse	VR	2 MVA	IGBT	Normal operation - 2% loss

PCS Cost

PCS companies were contacted and estimated cost structures were discussed. The companies interviewed were asked to provide the total cost of the PCS. The total cost for the PCS includes materials, labor, and overhead. Switchgears, transformers, and cabinets are also included in the total PCS cost. Shipping and installation costs are not included in the total PCS cost because they are site specific and highly variable.

In addition to the total PCS cost, manufacturers were asked to provide a percentage of the total cost for each of four major cost centers and to discuss potential near-term (within approximately two years) cost reductions. In many instances the suppliers were reluctant to give detailed cost information. To maintain PCS manufacturers' confidentiality, company names are not identified with the estimated cost structures. Nine out of the ten PCS companies interviewed provided cost information.

Most of the cost information was obtained during interviews with company representatives. Consequently, it must be understood that much of this information is highly subjective. The numbers given are approximations and are not meant to be provided as "hard" data, but merely to give a general idea of the system costs and potential areas for cost reduction. Additionally, the large-scale UPS market (100-1000 kW) is a mature and stable industry, and UPS manufacturers have aggressively pursued technology advances and cost-cutting measures for nearly two decades. Consequently, future cost savings in the UPS market (a power quality application) will probably be incremental (3-5% per year) rather than revolutionary. In the tables below, the cost reduction percentages, where available, are given in parentheses next to the percentage of the total system cost for each cost center.

Cost Breakdown and Cost Reduction Potential by Application

The ESSP developed an estimated cost breakdown structure for state-of-the-art PCS systems. The PCS cost was broken into four major cost centers—power stage, device drivers, PCS controller, and balance of system (BOS). The power stage consists of the topological connection of switching devices, its thermal management, and its protective circuits (such as snubbers). The nameplate rating of the power stage (which includes the ratings of its semiconductor devices and ancillary circuits), the chosen inverter topology, and the control requirements are all factors that determine the overall cost of the inverter. The device drivers are circuits that take input signals from the controller and effect the turn ON/turn OFF of the switching devices. The PCS controller includes the inner loop, outer loop, and functional control loop. The BOS includes the DC interface, the AC interface, and the magnetics. For this portion of the report, the primary magnetic components are transformers and filter inductors. Figure 32 shows the range for each cost center for grid-connected and grid-independent systems.

PCS Cost

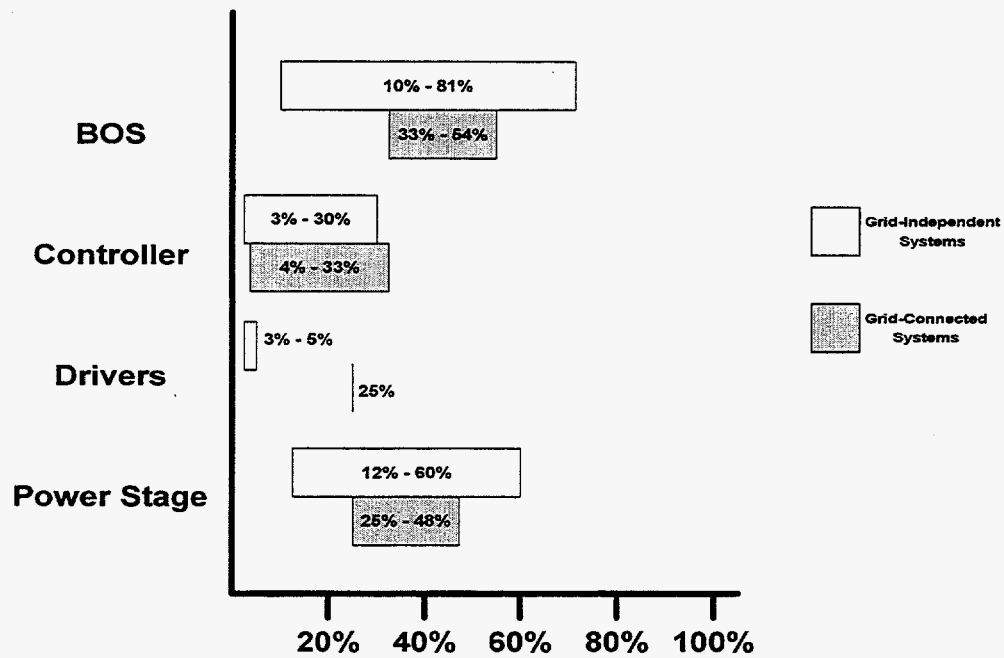

Figure 32. PCS cost breakdown.

A distinction must be made between balance of system and balance of plant. The balance of plant, as described in “Cost Analysis of Energy Storage Systems for Electric Utility Applications” (Akhil), encompasses the facility to house the entire energy storage system; heating, ventilation, and air conditioning (HVAC); the interface between the energy storage system and the customer or utility; the provision of services such as data gathering/trending and project management; and other charges associated with transportation, permits, training, spares, and finance charges. Because this paper focuses on PCSs, the BOS refers to the power converter, not the overall plant. The BOS is a variable figure and depends upon the type of energy storage and renewable generation devices and the type of configuration used to interface the ESS to the utility. The BOS cost is largely determined by the specific needs for the site and for the application.

PCS Costs for Power Quality Applications

The total PCS cost for power quality applications ranges from \$46/kW to \$400/kW as shown in Table 9. The \$46/kW cost applies to a situation where the PCS manufacturer supplies only the inverter, not the entire PCS. The \$60/kW cost applies to a situation where a large number of units (more than 10 per year) are produced at a time. The other cost figures (\$100/kW to \$400/kW), which represent the majority of the cost range, are for cases where only a few units (less than 10 per year) are produced each year.

Based on the data collected, the power stage ranges from 25% to 47.5% of the total PCS cost. In most instances the costs for the device drivers were hard to separate from the power stage costs. Consequently, device driver costs are not evaluated separately, but included in the power stage data. In some cases, the controller cost was combined with the device driver cost accounting for 25% of PCS cost, as one company suggested. The controller costs range from

4% to 33% of the overall PCS cost. The BOS costs ranged from 33% to 51% of the overall PCS cost.

Table 9. PCS Costs for Power Quality Applications

Company	Total \$/kW	Power Stage (% Reduction)	Device Drivers (% Reduction)	Controllers (% Reduction)	BOS (% Reduction)
A	\$400	33% (-30%)	in PS	33% (-30%)	33% (-30%)
B	\$300	47.5% (-30%)	in PS	5% (-30%)	47.5% (-30%)
C	\$100	NA	NA	NA	NA
D	\$90 - \$100	NA	NA	NA	NA
E	\$46	45% (-30-40%)	in PS	4% (-33%)	51% (ROI)
F	\$60	25% (-10%)	25% (-25%)	in DD	50% (+5%)
G	\$109	NA	NA	NA	NA
H	\$145	NA	NA	NA	NA
I	\$250	NA	NA	NA	NA
J	\$300	NA	NA	NA	NA

Most companies were hesitant to respond with cost and cost reduction potential. In general, the cost reduction potential for the power stage ranged from 10% to 30%, and for the controller from 30% to 33%, of the current cost. One company suggested that the costs of device drivers could be reduced by 25% in the near future. Potential cost reductions for the balance of system ranged from a reduction of 30% to a possible increase of 5%. Increases in balance-of-system costs are possible due to the rate of inflation (ROI) that may cause increases in the prices of materials (copper, steel, etc.) and labor.

PCS Costs for Voltage Regulation Applications

Three companies discussed PCS costs for voltage regulation applications, but only two provided cost breakdown information. As shown in Table 10, the total cost for a voltage regulation application ranges from \$150/kW to \$500/kW. The power stage accounted for 33% to 36% of the total PCS cost, the controller for 10% to 33%, and the balance of system for 33% to 54%. Both companies that gave detailed information (Companies A and B) included the cost of the device drivers in the power stage costs.

Table 10. PCS Costs for Voltage Regulation Applications

Company	Total \$/kW	Power Stage (% Reduction)	Device Drivers (% Reduction)	Controllers (% Reduction)	BOS (% Reduction)
A	\$400	33% (-30%)	in PS	33% (-30%)	33% (-30%)
B	\$500	36% (-30-40%)	in PS	10% (-33%)	54% (ROI)
C	\$150	NA	NA	NA	NA

The cost reduction potential for the power stage/device drivers ranged from 30% to 40% of the current cost. The companies also saw a potential 30% to 33% reduction in the cost of controllers. Company A estimated a 30% reduction could be achieved for the balance of system, however, Company B felt that the cost for the BOS fluctuated with the rate of inflation.

PCS Cost

PCS Costs for Customer Demand Peak Reduction Applications

Three companies supplied cost information for the customer demand peak reduction application, but only two provided cost breakdown information. The total PCS cost for this application ranged from \$420/kW to \$750/kW, as shown in Table 11. Both of the companies that provided detailed cost information (Companies A and B) included the cost of the device drivers in the power stage costs, which accounted for 32% to 36% of the total PCS cost. The controller accounted for 10% to 30% of the total PCS cost, and the BOS for 10% to 30%.

Table 11. PCS Costs for Customer Demand Peak Reduction Applications

Company	Total \$/kW	Power Stage (% Reduction)	Device Drivers (% Reduction)	Controllers (% Reduction)	BOS (% Reduction)
A	\$420	32% (-30%)	in PS	32% (-30%)	36% (-30%)
B	\$500	36% (-30-40%)	in PS	10% (-33%)	54% (ROI)
C	\$750	NA	NA	NA	NA

Companies A and B speculated that a 30% to 40% reduction in power stage costs could be achieved. It was anticipated that the lower-cost solid-state switches coming on the market could result in such a reduction. The cost reduction potential for controllers was estimated as being between 30% and 33%. Company A estimated a 30% reduction in balance-of-system costs in the near future; however, Company B stated that balance-of-system costs, and consequently any potential cost reductions, depend on the rate of inflation. For example, the cost of steel used for enclosures fluctuates according to the rate of inflation, as does the cost of copper and iron used in filters and transformers.

PCS Costs for Area Control/Frequency Regulation Applications

The cost estimates and cost reduction potentials for PCSs used in area control/frequency regulation applications were highly speculative and presented a wide cost range (see Table 12). Company A estimated the total PCS cost for this application as \$320/kW, while Company B estimated only \$80/kW. Both costs are based on low-volume production and in both estimates the cost of the device drivers was combined with the power stage cost. The device drivers and power stage accounted for 40% to 44.5% of the total PCS cost. The controller accounted for 4.7% to 6%, and the balance of system from 50.8% to 54%.

Table 12. PCS Costs for Area Control/Frequency Regulation Applications

Company	Total \$/kW	Power Stage (% Reduction)	Device Drivers (% Reduction)	Controllers (% Reduction)	BOS (% Reduction)
A	\$320	44.5% (-30%)	in PS	4.7% (-30%)	50.8% (-30%)
B	\$80	40% (-30-40%)	in PS	6% (-33%)	54% (ROI)

Company A suggested that a 30% cost reduction could be achieved for the power stage, controller, and balance of system. This reduction is based on high-volume production, which tends to reduce cost. Company B indicated that a 30 to 40% cost reduction was possible for the power stage and device drivers, based on the possible availability of higher-rated components in the near future. The use of higher-rated components would reduce the need for protective circuits for a high-power system, and consequently the costs associated with supplying those circuits. Company B sees a possible 33% cost reduction in controller technology primarily based on moving toward digital circuits from older, more expensive,

analog circuits. Company B stated that because the balance-of-system costs fluctuate with the rate of inflation they are unpredictable.

PCS Costs for Residential Applications

Three companies provided cost data relating to residential applications, but only two provided detailed cost information. The total PCS cost ranged from \$700 to \$1200/kW (see Table 13). Costs for the power stage ranged from 22% to 60% of the total PCS cost. Company A included the costs for the device drivers in the power stage cost. Company B estimated the device drivers cost at 5% of the total PCS cost. The controllers ranged from 22% to 30% of the total cost, and the balance of system from 10% to 51%.

Table 13. PCS Costs for Residential Applications

Company	Total \$/kW	Power Stage (% Reduction)	Device Drivers (% Reduction)	Controllers (% Reduction)	BOS (% Reduction)
A	\$1100-1200	60% (NA)	in PS	30% (NA)	10% (NA)
B	\$700	22% (-10%)	5% (-30%)	22% (-30%)	51% (-15%)
C	\$944	NA	NA	NA	NA

Company A and Company C did not discuss potential cost reductions. Company B estimated a 10% cost reduction in the power stage, a 30% reduction in device drivers, a 30% reduction in controllers, and a 15% reduction in the balance of system in the near future. The anticipated reduction in power stage costs was based on the advancement of semiconductor switches. Higher-rated switches need fewer protective circuits, and fewer circuits reduce the cost of the power stage. The reduction in the cost of device drivers could be achieved if the current design was fully optimized for the application. The reduction in controllers would be possible if current analog circuits are replaced with newer, cheaper digital circuits. The balance-of-system costs could be reduced if the costs of enclosures and magnetics were reduced due to higher-volume production.

PCS Costs for Small Village Applications

Three companies provided total cost data, but only two provided information by cost center and information on potential cost reductions. The total PCS cost for these applications ranged from \$490 to \$858/kW, as shown in Table 14. In comparison, costs for a rotary-converter-based PCS were reported at \$250 to \$350/kW. The power stage represented 19% of the total PCS cost for Company A, but did not include the cost of the device drivers (5%). The power stage and device drivers accounted for 30% of the total PCS cost for Company B. Both companies estimated the cost of the controllers at 11% of the total PCS cost. The balance-of-system costs ranged from 50% to 65%.

Table 14. PCS Costs for Small Village Applications

Company	Total \$/kW	Power Stage (% Reduction)	Device Drivers (% Reduction)	Controllers (% Reduction)	BOS (% Reduction)
A	\$490	19% (-10%)	5% (0%)	11% (-30%)	65% (-15%)
B	\$650	30% (-10-15%)	in PS	11% (-33%)	59% (ROI)
C	\$858	NA	NA	NA	NA

PCS Cost

Potential cost reductions for the power stage ranged from 10% to 15%. Company A, which did not include device drivers in the power stage cost, did not anticipate any cost reductions in the device drivers. Both companies felt that controller costs could be reduced by 30% to 33%. Company A believed that a 15% reduction in balance-of-system costs was possible, while Company B stated that balance-of-system costs vary with the rate of inflation and, consequently, cost reductions were unlikely.

PCS Costs for Large Village/Small Industrial Applications

Three companies provided total cost data, but only two provided information by cost center and information on potential cost reductions. The PCS cost for large village/small industrial ranged from \$200 to \$647/kW, as shown in Table 15. The \$200/kW figure was based on large volume production. For Company A, the cost center percentages were 12% for the power stage, 3% for the device drivers, 3% for the controllers, and 81% for the balance of system. For Company B the cost center percentages were 24% for the power stage and device drivers combined, 5% for the controllers, and 71% for the balance of system.

Table 15. PCS Costs for Large Village/Small Industrial Applications

Company	Total \$/kW	Power Stage (% Reduction)	Device Drivers (% Reduction)	Controllers (% Reduction)	BOS (% Reduction)
A	\$420	12% (-10%)	3% (0%)	3% (-30%)	81% (-10%)
B	\$200	24% (-10-15%)	in PS	5% (-33%)	71% (ROI)
C	\$647	NA	NA	NA	NA

Company A saw a cost reduction potential of 10% in the power stage, no reduction potential in device drivers, 30% for controllers, and 10% for balance of system. Company B saw a cost reduction potential of 10 to 15% in the power stage including the device drivers, 33% in controllers, and the BOS cost as rising and falling with the ROI.

Discussion of Potential Cost Reductions and Cost-reduction Conclusions

In general, grid-independent systems cost more than grid-connected systems (see Figure 33). Some possible contributing reasons for the higher cost are listed below:

- Typical interfaces for grid-independent systems are quite complex when compared with those for grid-connected systems. Additional work is required to interface multiple devices such as PV, batteries, and engine generators, which contributes to higher costs for control hardware and software.
- Most grid-independent systems are one-of-a-kind systems, which results in one-time engineering costs that are added to the price of the system. The engineering costs cannot be distributed among several systems.
- Grid-independent systems are generally produced in much smaller volume than grid-connected systems. Generally in manufacturing, higher-volume production results in lower costs.

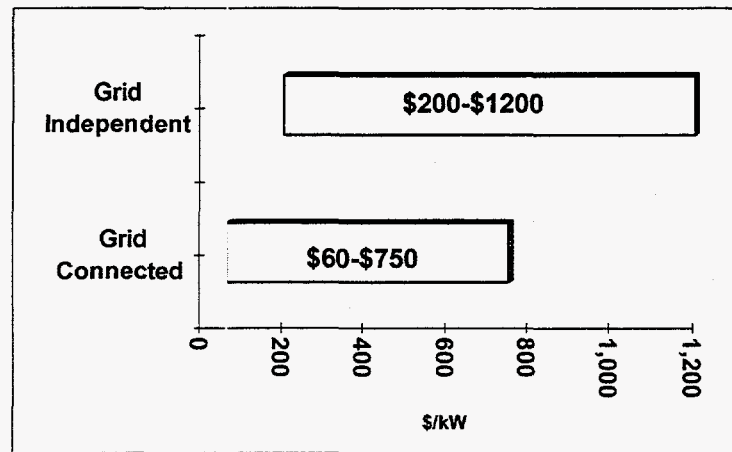

Figure 33. Current PCS costs.

Figure 34 shows the estimated range of potential near-term (within approximately two years) cost reductions for each of the cost centers. PCS developers predict that volume production provides the greatest potential for cost reduction, but market demand, which would justify higher-volume production, has not yet emerged. PCS manufacturers believe that once application and product needs become more clearly defined, a significant market will develop which will likely reduce the cost of PCSs. A well-designed manufacturing process could also decrease costs. Enhancements in manufacturing techniques, along with mass production, usually result in both higher-quality devices and reduced manufacturing costs.

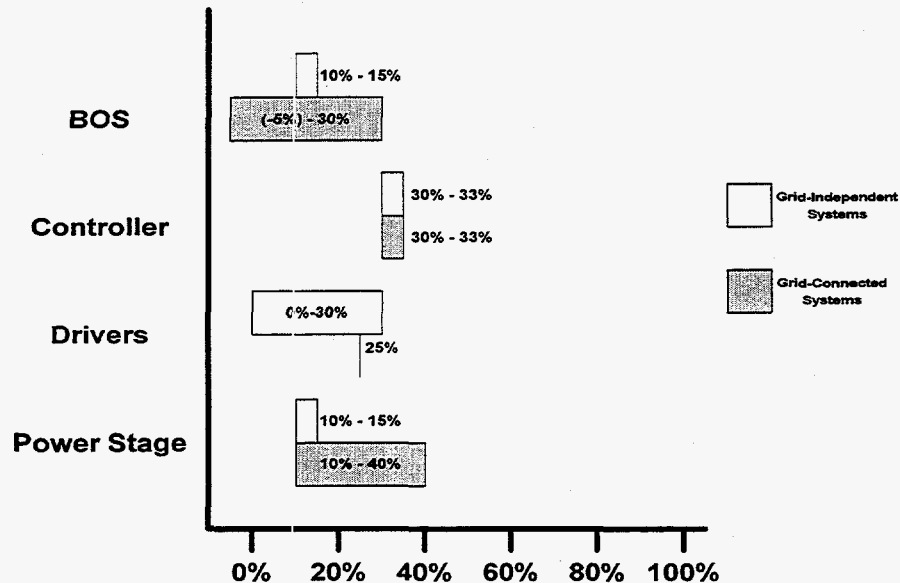

Figure 34. Near-term (within approximately two years) cost reduction potential.

Some PCS manufacturers are advancing the concept of modular PCSs to reduce costs. These manufacturers feel that lower-power PCSs are probably easier and cheaper to produce and can be networked together using software to achieve the same rating as a single high-power PCS. However, industry experience indicates that the PCS cost (in \$/kW) tends to decrease as the PCS rating increases. This is probably because the cost of the controller, generally, is

fixed—it is the same for both high- and low-rated units. Consequently, the same controller can be used for both higher- and lower-power systems.

Higher component integration and increased functionality per unit area, such as that which could be achieved by replacing analog components with digital components in controller circuits, could also result in cost reductions as well as a smaller package. The sophisticated internal processes, such as self-testing, in digital controllers simplify controller maintenance and diagnostics. Digital circuits also require fewer calibrations and less testing and set-up time compared to analog circuits.

Some cost reductions may also be realized from advances in semiconductors. IGBTs are currently leading the market for semiconductors used in medium-level (up to 750 kVA) PCSs (Walden). IGBT technology has wide industry support and is most likely to provide the greatest cost reduction potential for the near future (Nilsson). Advanced semiconductors have increased switching speeds that allow for higher operating frequencies, which in turn reduce the size of filters and other passive components. Increases in semiconductor voltage and current ratings could also reduce the number of switches required for higher-rated systems while improving reliability and reducing the design complexity. Fewer semiconductor switches would reduce the need for protective circuits (such as snubbers) and elaborate heat sink designs, thus reducing the overall cost. Nevertheless, higher-rated components will only help reduce cost to a certain degree. Three-phase operation, for instance, will still require at least six semiconductor switches for a converter.

Possibly the greatest cost reduction in PCS development would come from combining modular semiconductor switching devices with advanced microprocessor controllers. The trend in industry appears to be toward modular component designs that use advanced controllers; for example, some manufacturers are placing the entire inverter power stage in a single package with one heat sink. This standardization of a single, modular package that could be used for a variety of applications by slightly modifying the software could reduce or eliminate the need for custom-designed PCSs. Modular design tends to reduce noise sensitivity in components and EMI, but has a tendency to require increased complexity in the heat sinks used in the devices. This modular concept is currently being pursued by the federal interagency PEBB program.

The potential cost reductions discussed above require design enhancements that can increase the initial design cost of the PCS. However, the cost of PCS components and subassemblies are generally on a downward trend. Advances in technology are expected in the areas of packaging, semiconductors, and power conversion topologies. These advances may help reduce the number of parts required and the size of the units, and combined with increased demand and higher production, will probably result in lower PCS costs in the future. Finally, most manufacturers agreed that they would like to see reductions in the cost of the magnetic components (transformers, filter inductors, etc.) and do not feel that much work is being done in this area.

Applicable or Relevant Standards and Codes

The design, installation, and operation of electrical equipment is governed by standards and codes. Other than UPSs, which are widely used, only a small number of energy storage systems are currently operating in the United States. Consequently, specific standards and codes have not been developed for systems other than UPSs, or for the inverters used in these systems. Pending the development of specific standards, several existing standards and codes may be considered to apply to energy storage systems and inverters.

Electrical Equipment Installation Codes

These codes pertain to electrical equipment, rather than entire systems. The prevalent codes in the US are the National Fire Protection Association (NFPA) National Electrical Code (NEC), Articles 70 and 690; and Underwriters Laboratory (UL), Article UL1741.

National Fire Protection Association National Electric Code

The NEC is revised and published every three years by the NFPA. It is the most widely used code in the US for installing electrical equipment and has been adopted as law in many states, counties, and cities. The NEC emphasizes safety and fire prevention. The code is not applicable to electrical systems owned or operated by electric utility companies.

NEC Article 70 applies to energy storage systems (up to 600 V) used in residential and commercial (non-utility) facilities. It specifies the means and location of disconnects required to completely isolate the inverter. It also provides specifications for wiring type, wire type, and wire size; neutral and grounding requirements; and amperage requirements. These requirements apply to all DC and AC wiring external to the inverter enclosure.

NEC Article 690, which applies to solar PV systems, is currently in the process of being updated. The NEC definition of a solar PV system includes grid-independent, grid-connected, and hybrid systems. In this article, higher operating voltage ranges than those specified in Article 70 are being defined for PV systems. Article 690 will also contain specifications for the inverters used in solar PV systems.

Underwriters Laboratory

Underwriters Laboratory emphasizes safety and lists equipment that meets its standards. The UL standard that may be most relevant for inverters is UL1741, "Standard for Inverters, Charge Controllers, and AC Modules for Use in Residential Photovoltaic Systems."

Electrical Systems and Interface Codes

These codes apply to the installation of entire systems and the systems' interface to a utility grid and/or the load.

American National Standards Institute/Institute of Electrical and Electronic Engineers

ANSI/IEEE develops standards, recommended practices, and guidelines for electric equipment and systems (for utility use) and for commercial/industrial equipment (such as

Applicable or Relevant Standards and Codes

electric motors) in collaboration with the NFPA, UL, National Electrical Manufacturers Association (NEMA) and others. ANSI/IEEE standards are widely incorporated by reference in work involving the transmission and distribution of electricity, but sometimes defer to local standards and codes. ANSI/IEEE has not yet developed standards, recommended practices, or guidelines for general energy storage systems; however, standards related to the interconnection of static power converters, PV systems, and high-voltage direct current (HVDC) and static VAR systems are relevant. Additionally, an energy storage system used for any of the applications described in this report may readily be classified as a “dispersed storage and generation facility” and standards related to such facilities will be relevant.

Specific Standards Applicable to Inverters

IEEE 1001, “Recommended Practice for Interfacing Dispersed Storage and Generation Facilities with Electric Utility Systems.”

WG C5 (special publication), “Static Power Converters Serving as the Utility Interface Package.”

IEEE519, “Guide for Harmonic Control and Reactive Power Compensation of Static Power Converters.”

Specific Standards Applicable to Photovoltaic Systems

ANSI/IEEE 928, “IEEE Recommended Criteria for Terrestrial Photovoltaic Systems.”

ANSI/IEEE 929, “IEEE Recommended Practice for Utility Interface of Residential and Intermediate Photovoltaic Systems.”

Federal Communications Commission

FCC regulations are primarily concerned with electromagnetic emissions from the inverter that could interfere with radio and television broadcasting and the susceptibility of the inverter to ambient electromagnetic radiation. Specific requirements are contained in FCC Rules and Regulations Part 15, Subpart J. Generally, compliance with FCC regulations is not difficult to achieve and does not require specific design considerations in the inverter.

Other Related Codes and Standards

National Electric Safety Code

The National Electric Safety Code (NESC) is the ANSI standard that covers “supply and communication lines, equipment, and associated work practices employed by an electric supply, communication, railway, or similar utility in the exercise of its function as a utility.” Parts of the NESC are incorporated by reference in the NEC and vice versa. Although the guidelines contained in the NESC are directed at electric utilities and utility equipment, ESS system designers, integrators, and component manufacturers should be aware of the code. In cases where an ESS and its inverter are integrated into a utility system (for example by installation in a substation), the NESC would presumably apply. Similarly, in many instances

Applicable or Relevant Standards and Codes

the AC side BOS (switchgears, disconnects, etc.) usually must conform to both NEC and NESC requirements for grid-connected systems.

The following sections are of particular relevance for the systems described in this report:

- Section 9, "Grounding Methods for Electric Supply and Communication Facilities,"
- Section 12, "Installation and Maintenance," and
- Section 14, "Storage Batteries."

International Electrotechnical Commission

International Electrotechnical Commission (IEC) standards are adopted in Europe and by many non-European countries. The coverage of these standards is comparable with that of ANSI/IEEE in the United States and there is currently significant effort (in the electric energy industry in particular) to harmonize the standards. As in the case of ANSI, the IEC does not have specific standards directly related to ESS or ESS inverters. The IEC-60000 series covers many issues such as harmonics, power quality, and testing for utility interface of power electronic equipment. Some of these standards are listed below. Note: An "EN" designation indicates a standard developed by the European Committee for Standardization; a "PNW" designation indicates a standard that is still in process.

Published Standards

IEC 60146-2 (1974-01), "Semiconductor Converters," Part 2, "Semiconductor self-commutated converters."

IEC 60146-4 (1986-09), "Semiconductor Converters," Part 4, "Method of specifying the performance and test requirements of uninterruptible power systems."

IEC 60411-2 (1978), "Power converters for electric traction," Part 2, "Additional technical information."

IEC 61000-2-1 (1990-05), "Electromagnetic compatibility," Part 2, "Environment," Section 1, "Description of the environment—Electromagnetic environment for low-frequency conducted disturbances and signaling in public power supply systems."

EN 61000-3-2 (1995), "Measurement of harmonics that applies to all equipment with an input current of greater than 16A" (originally based on IEC Standard 555-2).

IEC 61000-3-6 (1996-10), "Electromagnetic compatibility," Part 3, "Limits," Section 6, "Assessment of emission limits for distorting loads in MV and HV power systems."

IEC 61000-4-7 (1991-08), "Electromagnetic compatibility," Part 4, "Testing and measurement techniques," Section 7, "General guide on harmonics and interharmonics measurements and instrumentation for power supply systems and equipment connected thereto."

IEC 61071-1 (1991-10), "Power electronic capacitors," Part 1, "General."

IEC 61377 (1996-05), "Electric traction—Rolling stock—Combined testing of inverter-fed alternating current motors and their control."

Applicable or Relevant Standards and Codes

IEC 61642 (1997-09), "Industrial AC networks affected by harmonics—Application of filters and shunt capacitors."

Standards in Process or Under Revision

IEC 61000-3-4 TR2, Edition 1.0, "Electromagnetic Compatibility," Part 3, "Limits," Section 4, "Limitation of emission of harmonic currents in low voltage power supply systems for equipment with rated current greater than 16A."

IEC 61000-3-9, Edition 1.0, "Electromagnetic Compatibility," Part 3, "Limits," Section 9, "Limits for interharmonic current emissions (equipment with input power greater than or equal to 16 A per phase and prone to produce interharmonics by design.)"

IEC 61000-4-7, Edition 2.0, "Electromagnetic compatibility," Part 4, "Testing and measurement techniques," Section 7, "General guide on harmonics and interharmonics measurements and instrumentation for power supply systems and equipment connected thereto."

IEC 61000-4-13, Edition 1.0, "Electromagnetic compatibility," Part 4, "Testing and measurement techniques," Section 13, "Test for immunity to harmonics and interharmonics including mains signaling at AC power port."

IEC 61000-4-30, Edition 1.0, "Electromagnetic compatibility," Part 4, "Testing and measurement techniques," Section 30, "Measurement of power quality parameters."

IEC 61400-21, Edition 1.0, "Power quality requirements for grid-connected wind turbines."

IEC 61427-1, Edition 1.0, "Secondary cells and batteries for photovoltaic solar energy systems," Part 1, "General requirements and methods of test."

IEC 61728, Edition 1.0, "Safety test procedures for utility grid-connected photovoltaic inverters."

PNW 77A-225, Edition 1.0, "Limits for harmonics produced by equipment connected to public low-voltage systems with input current above 16A."

Conclusions

The following general observations were made during the course of this study:

- The UPS area is a mature example of energy storage systems and cost-effective and reliable PCSs.
- Most fielded systems use tried and proven inverters.
- Most fielded systems require one-of-a-kind controllers.
- Fielded systems at 500 kVA and below generally use IGBTs and hard-switched bridge topologies.
- Systems in excess of 10 MW generally use SCRs and GTOs.
- There are very few fielded ESSs in the 1- to 10- MW range. The lack of technology in this range may be because (1) it is convenient to keep pilot projects in the lower kVA range, (2) this range requires higher voltage/current devices, and/or (3) the market potential in this range is unclear.
- Higher power ratings could be achieved using a modular approach in which PCSs are connected in series/parallel arrangements, but few demonstrated systems have used this approach.
- Soft switching is becoming a mature technology in the 250-kVA range and can provide advantages over hard switching.
- Higher-rated devices that can switch at high frequencies would be beneficial.
- Topologies such as multilevel converters could be beneficial.
- The cost centers that were reasonably clearly identified as having potential for cost reduction are the power stage, the controller, and the BOS (specifically, the magnetic components).

Additionally, two analogies can be drawn with respect to the current state of PCS development and technology. First, PCSs are now at the state that personal computers were at in the early- to mid-1980s—they are highly-proprietary, and thus, very expensive. During the meetings with industry, a great deal of discussion focused on how to reduce the costs of building PCSs for, and integrating PCSs with, energy storage technology. It is thought that with greater standardization of PCS components and entire PCSs the costs will be reduced. Standardization should greatly increase the volume of production, which generally reduces costs, because common manufactured components will be able to be used in a wide variety of systems. Additionally, standardization of both components and entire PCSs will greatly reduce the engineering costs of any particular system. It is anticipated that by reducing the cost of designing and building PCSs, the cost reductions will be passed on to system integrators, and finally, to the end user, which in turn should increase demand for these systems.

The second analogy is taken from the automotive industry. From the discussions with industry, it is not clear whether customers need a high-end, and consequently high-dollar, "luxury" model converter or if a simpler, and cheaper, "transportation-only" model will do. The converters that are currently being manufactured are expensive, engineering-intensive devices that have a wide range of available features and options. Indeed, because the systems are generally engineered to meet the specifications of an individual user or system integrator, the converter's design is limited only by customer specifications and the technology of the components. In other words, they are luxury models. It is not clear from the study whether

Conclusions

such devices are “necessary” (required by the customer for specific reasons) or are simply the result of enthusiastic engineering.

Of interest is whether customers (system integrators and end users) would prefer more economical, “transportation-only” converters. Presently, the market for PCSs is still relatively small and is not well-defined. Additionally, a “Model T” of converters has not been developed. It is not clear if the development of a mass market, affordable converter that could be used for a wide variety of applications would do for the PCS market what the Model T did for the automobile market, but it is a question worth exploring. Perhaps once the market is larger and more well-defined, and once competition between manufacturers increases due to standardization and mass-production of PCSs and components, customers may recognize the need for additional features and options and start asking for them. Additionally, while some customers may be asking for newer, “luxury” model converters, a wide segment of the market may still be satisfied with the “economy” models. Currently, however, a question also exists as to the actual cost benefits of the more low-end converters. Unlike the Model-T, it is not clear at this time that providing a converter with minimal specifications would dramatically reduce its cost. This is another question that, while beyond the scope of this report, would be interesting to explore further sometime in the future.

Recommendations for Future Research and Development

This section provides R&D recommendations for future PCS development. The list of recommendations, provided in priority order, highlights key findings on R&D needs and opportunities from various discussions with representatives from industry, academia, and the national laboratories. Some individual responses from industry representatives are provided in Appendix E.

Support the Near-term Development of Higher-rated Semiconductor Switches

Many companies expressed the need for higher-rated semiconductor devices. Cost-effective devices are sometimes not available for applications in the megawatt range. Industry currently uses two approaches to configure PCS semiconductors for high-power applications. The first approach is to connect the available semiconductor devices in series/parallel arrangements. Extra devices are used to ensure reliability at high power. The cost, however, tends to increase sharply because of the additional circuits and controls needed to balance voltages and current through the devices. It is both preferable and advantageous to use the fewest possible number of semiconductor devices in the power stage. Using fewer semiconductor switches reduces the number of protective circuits (such as snubbers), reduces the complexity of heat sink designs, and increases reliability. There is, however, a limit to how many semiconductors may be eliminated in any given circuit. For example, an inverter used for three-phase operation requires at least six semiconductor devices. The second approach is to use series/parallel connections of inverters (as opposed to semiconductors) with the appropriate control algorithm to ensure current/voltage sharing. Both of these approaches increase the complexity, and consequently, the cost and size of the PCS. The development of advanced semiconductor switches specifically designed for high-power applications would probably reduce both the footprint and cost of the PCS.

Explore the Options Available for Cheaper, Lighter, and Smaller Magnetics and for Reducing the Cost of Filter Inductors and Line-frequency Transformers

Most companies agreed that very little R&D is being done in this area. They stated that filter inductors tend to be custom and expensive. Some companies indicated that it is hard to find manufacturers who understand the engineering behind magnetics well enough to provide components that meet their needs. It is thought that cheaper, lighter, and smaller magnetics and magnetic components that minimize power losses that occur during high-frequency operation would improve PCS performance and reduce cost and footprint.

Magnetic transformers have a tendency to have high power losses. Recent advances in semiconductor technologies and inverter topologies could ultimately eliminate the need for line frequency transformers and reduce the need for filter inductors. ORNL, for example, is working on multilevel converters that would allow the converter to be tied directly to the utility grid without transformers. Another approach is to increase the operating frequency of the transformers. The introduction of a high-frequency transformer also holds some promise for reducing the footprint of the transformer and possibly reducing the overall cost. Increasing the transformer's operating frequency has a tradeoff; it may increase the number of converters required for some systems. For example, in a typical battery-storage-based power quality application the DC power from the batteries is converted to 60-Hz AC power,

Recommendations for Future Research and Development

which is then fed through a 60-Hz transformer. Introducing a high-frequency transformer in such a system would require a transformation of DC power to high-frequency AC power by feeding it through a high frequency transformer. The high-frequency AC power must then be transformed to 60-Hz AC power to the load via the power converter. Such a system would increase the number of conversions required while reducing the size, cost, and losses of the transformer; however, the cost of the system may be increased because of the number of conversions necessary. Recent reductions in converter costs might make this a viable option. The third approach is to develop advanced core materials in magnetics, such as amorphous materials, to reduce losses, footprint, and cost. All three of these approaches have similar goals of reducing the cost, size, and losses of transformers, filters, and other magnetic components.

Research Advances in PCS Controllers for Hybrid ESSs, Including Reducing Software Development Time and Cost

Historically, there have been some misunderstandings between renewable resource suppliers, energy storage suppliers, PCS manufacturers, systems integrators, and end users. These misunderstandings have resulted in systems in which the individual components (PV arrays, wind generators, engine generators, storage devices, and power conversion subsystems) do not always operate optimally within a given system. Usually, this less than optimal performance means that the performance and life span of both the individual components and the system as a whole are less than the specifications of the individual components lead end-users to expect. Consequently, the life-cycle cost for hybrid systems has been higher than it could have been had all of the components performed optimally.

R&D is therefore needed for the development of advanced supervisory controller software that could maximize the performance of the components and the system, which in turn would reduce the life-cycle cost of hybrid systems. The components of life-cycle cost that might ultimately be reduced by the development of an advanced controller include capital, maintenance, repair, and operational costs (for example, fuel). Current discussions with industry indicate that the development of a supervisory controller that is capable of determining when and how each component of a hybrid system should be used would reduce system costs and result in system performance that is more closely aligned with the users' expectations and the component specifications.

Additionally, most hybrid systems are one-of-a-kind systems that incur one-time software engineering costs, which are added to the price of the system. A typical control system for a solar hybrid system, for example, is usually quite complex and requires longer development time than a non-hybrid system. More specifically, on a recent contract with the US Navy in which Trace Technologies provided a power conversion and control system for a large-scale hybrid diesel-photovoltaic power system, over 40% of Trace Technologies' costs were software related. These costs included developing appropriate control algorithms, coding the algorithms, testing and debugging the code, and on-site tuning of the software after installation. Many solar hybrid systems, however, are similar or identical and provide opportunities for standardizing the control software. Consequently, additional R&D opportunities exist specifically for reducing development time and cost for hybrid system controller software.

Encourage R&D into Advanced Converter Concepts Specifically for Energy Storage Applications

Inverters can, in general, be grouped into several different categories, or families, which are discussed in detail in Appendix B. Currently, there is not a single, "best" inverter for grid-connected systems in the 1- to 10-MW range. Within each inverter "family" there are many existing topologies and additional topologies are in the R&D stage. The results of this study do not make clear which topologies are best suited for use with the energy storage technologies of interest to the ESSP (i.e., batteries, flywheels, SMES). Often, PCS manufacturers have invested a great deal of time and money on a topology designed for a well-defined and existing market, such as motor drives. Consequently, they are sometimes hesitant to investigate other converter topologies for applications and markets that are less well defined. They are more likely to simply modify an existing topology for use in a new application without extensive study into what would be optimal for that application. The ESSP should encourage further R&D to determine what should be considered the optimal inverter topology or topologies specifically designed for energy storage systems.

Support the Development of Standards and Codes Specifically Related to the PCSs Used with Energy Storage Systems and Renewables

The design, installation, and operation of electrical equipment is governed by standards and codes. Because there are very few energy storage systems in operation, specific standards and codes have not yet been developed for such systems or for the inverters used in such systems. Although there are several standards and codes that may be relevant to ESS, there is a need to develop standards specifically for energy storage systems. These standards should address the unique requirements of energy storage systems in terms of design, installation and operation of the electrical equipment both for grid-connected and grid-independent systems. Additionally, collaboration with other standards development activities is needed to define the final PCS standards and codes related to energy storage systems and renewables.

Appendix A—List of Companies Interviewed

ABB Industrial Systems, Inc.
Tor-Eivind Moen, Product Manager for Power Electronic Systems
Anders Troedson, Director of Power Electronics
New Berlin, Wisconsin

AC Battery Corporation
William T. Johnson, Applications Engineer
William J. Nerbun, Product/Marketing Manager
Don C. Vanderbrook, Operations/Engineering Support Manager
Daniel H. Zietlow, Project Engineering Manager
East Troy, Wisconsin

Abacus Controls, Inc.
Richard T. Pichnarczyk, Vice President
George O'Sullivan, President
Somerville, New Jersey

Active Power
Jim Balthazar, Vice President of Marketing
Austin, Texas

Advanced Energy Systems
Mark Hensely, Marketing Manager—Americas
Rob Wills, President and CTO
Wilton, New Hampshire

American Superconductor (formerly Superconductivity, Inc.)
Mike Gravely, Executive Vice President Markets/Business Development
Middleton, Wisconsin

Exide Electronics
John Breckenridge, Director of North American Service Operations
John Messer, Director of Design & Development Engineering
Raleigh, North Carolina

Exide Electronics
Thomas F. Skuce, Program Specialist
Antelope, California

International Computer Power, Inc.
James T. LoGudice, Technical Sales Manager
El Monte, California

Appendix A—List of Companies Interviewed

International Rectifier

Tim McDonald, Director of Project Engineering for IGBTs
Haim Taraseiskey, Advanced Products Marketing Manager, Switch Products
El Segundo, California

Liebert Corporation

Richard A. Walden, Manager of Integrated Power Systems
Irvine, California

Northern Power Systems (formerly The New World Power Technology Company)

Ed Linton, Senior Electrical Engineer
Jonathan A. Lynch, Director of Engineering
Waitsfield, Vermont

Northrop Grumman

L.E. Lesster, Manager—Vehicle and Energy Program
Baltimore, Maryland

Oak Ridge National Laboratories

Donald J. Adams, Group Leader—Digital and Power Electronics Engineering Technology
Division
Robert A. Hawsey, Manager—Superconductivity Program
John W. McKenner, Ph.D., Senior Research Engineer/Project Manager—Engineering
Technology Division
Leon M. Tolbert, P.E., Electrical Engineer—Power Electronics Center, Engineering
Technology Division
Jim Vancoevering, Manager—Power Systems Technology Program
Oak Ridge, Tennessee

Omnion Power Corporation

Mark Haug, Sales Manager
Hans Meyer, President
David E. Porter, Vice President—Technology
East Troy, Wisconsin

Orion Energy Corporation

Douglas R. Danley, President
Iajmsville, Maryland

PDI Corporation

Richard A. Combs, President/CEO
John Kammeter, Vice President-Engineering
Sandston, Virginia

Powerex, Inc.

Eric R. Motto, Senior Applications Engineer
Youngwood, Pennsylvania

Appendix A—List of Companies Interviewed

Silicon Power Corporation (SPCO)
Roberto M. Andraca, Applications Engineer
Harshad Mehta, Ph.D., President/CEO
Stig L. Nilsson, P.E., Executive Vice President
Malvern, Pennsylvania

Soft Switching Technologies
Deepak Divan, President
Trevor Grant, P.E., Vice President—Marketing
Middleton, Wisconsin

TRACE Technology Corporation
Mike Behnke, Vice President
Livermore, California

United States Office of Transportation Technologies
David Hamilton
Washington, DC

University of Texas at Austin
Center of Electromechanics (CEM)
John Pappas, Research Engineer Associate
John H. Price, Research Associate
Austin, Texas

Westinghouse Electric Corporation
Thomas A. Lemak, Manager—Power Electronics Department, Science and Technology
Center
Pittsburgh, Pennsylvania

ZBB Technologies, Inc.
Phillip A. Eidler, President
Wauwatosa, Wisconsin

Appendix B—Inverters

Introduction

The focus of this report is power conversion technology for interfacing energy storage systems to stand-alone loads or to an electric power grid. Depending on the type of energy storage system, the power conversion system may actually contain several subsystems. There may be a need to condition or otherwise regulate the output of the energy source. However, the final conversion stage generally involves converting energy at direct voltage and current (DC) to energy at alternating voltage and current (AC) at a specific frequency. This AC to DC conversion is accomplished by the PCS inverter.

This appendix provides background material to support the evaluation of inverters suitable for power conversion from energy storage systems in the following four sections:

- The Basic Inverter
- Specific Converters
- Inverter Control
- Conclusion

The first section, "The Basic Inverter," describes the inversion process—the process of converting DC power to AC power. The first section also discusses how waveform control is achieved. Waveform control is an important issue in power conversion systems. Basically, AC waveforms are required to approximate sinusoids. In the higher-power range (10 MW and higher) available switching devices are limited to the silicon controlled rectifier (SCR) and the gate turn off thyristor (GTO). The MOS-controlled thyristor (MCT) is now available and showing promise. Waveform control in these circuits is achieved by phase-shifted series-parallel connections of bridges, augmented by passive and active filters. The medium power (1-10 MW) range could utilize either the same techniques as the higher range, or series/parallel connections at the low-power device or inverter level. There are few commercial applications in the medium power range. In lower power ranges (1 MW and lower) faster devices such as IGBTs, MOSFETs and bipolar transistors can be used. Waveform control is then achieved by the principle of pulse-width modulation (PWM).

The second section, "Specific Converters," describes several different types of converters in detail. "Converter" is a general term used to describe the following four types of power conversion: AC to AC, AC to DC (rectification), DC to DC, and DC to AC (inversion). The term "inverter" is more restrictive; it applies to those devices used solely for converting DC power to AC. Although the majority of converters use the bridge circuit, the type of switches used in the circuit varies based on the application and designer preference. Additionally, converters may be classified as either line-commutated, force-commutated, or self-commutated. Each of these three categories may be further divided into those based on hard-switching and those based soft-switching technologies. The second section discusses the various types of converters and the differences between hard- and soft-switching technologies.

The third section discusses basic inverter control. The control elements can be divided into three parts, or loops. The first part, the inner control loop, includes the generation of the requisite control signals (for example the PWM signal) and the circuits necessary to actually

Appendix B—Inverters

switch devices ON and OFF. The second part, the outer control loop, involves determining the required parameters associated with the above control signals to effect a desired objective, such as the control of the resulting AC voltage. Finally, the third level of control, the functional control loop, incorporates the control of the total energy storage system and specifies, for example, the desired AC voltage.

The Basic Inverter

Voltage- and Current-source Inverters

Figure B-1 shows the simplest inverter that delivers energy from a battery to a resistive load. The ideal battery produces a voltage, E , that is DC—that is, it does not change with time as illustrated in the time waveform at the bottom left of the figure. The battery is connected to a bridge of switches. Each switch can be turned ON or OFF. When ON, the switch conducts current in the direction of the arrow.

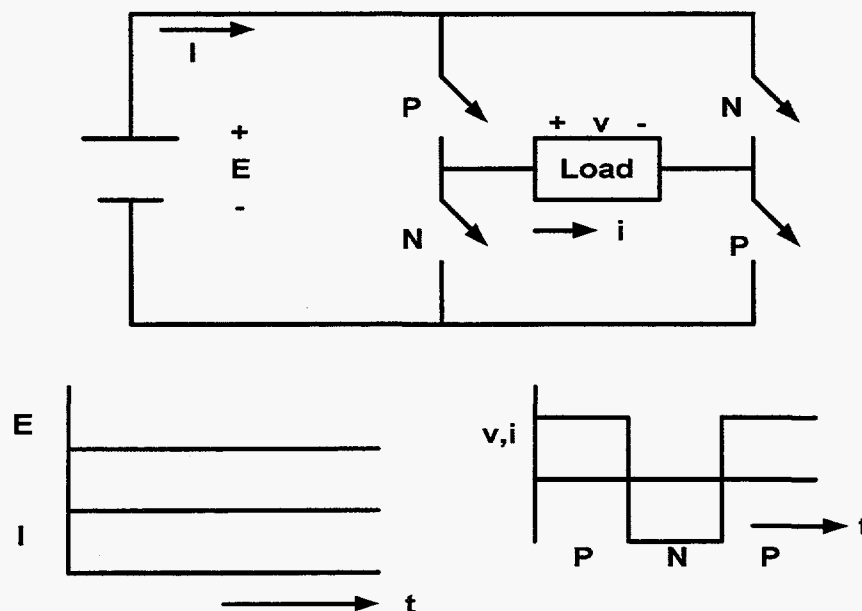

Figure B-1. Basic voltage-source inverter with resistive load.

The voltage-source inverter operates by alternately turning the P and N switches ON and OFF. When the P switches are ON a positive voltage, equal to battery voltage E , is applied to the load; when the N switches are ON the load voltage becomes the negative of the battery voltage (i.e., $-E$). Thus, a periodic AC voltage is synthesized at the load, which appears as the square wave shown at the bottom right of the figure. In a resistive load, the waveforms of voltage (v) and current (i), are identical. Thus an alternating current results. The current (I) from the battery is DC.

Alternatively the circuit in Figure B-1 can be supplied from a DC current source as shown in Figure B-2. The circuit injects a square wave of current into the resistive load and, consequently, is called a current-source inverter. Both voltage-source and current-source inverters are widely used. Although the current-source inverter would appear to be the most appropriate choice for use in a SMES-based system, and the voltage-source inverter the most

appropriate choice in a battery-based system, the final choice depends on the application and on the designer's preference. Comparative advantages and disadvantages of each type of inverter are discussed later in this appendix.

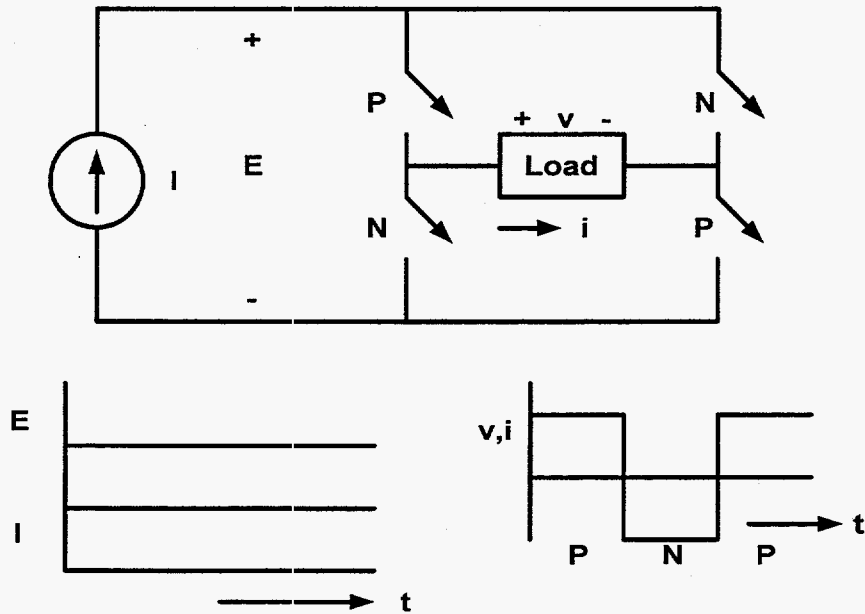

Figure B-2. Current-source inverter (with square-wave switching).

Practical Considerations for Inverter Design

The waveforms of the AC voltage and current in Figure B-1 and Figure B-2 are square waves. In practice, it is desired that AC systems operate with sinusoidal waveforms as shown in Figure B-3. Further, typical loads have reactive (inductive and capacitive) components. If the voltage is nonsinusoidal, the current will not have the same shape as the voltage; and even if both waveforms *are* sinusoidal, the current may not be in phase with the voltage. Ensuring that the waveforms are as nearly sinusoidal as possible, and that the current has the desired phase relationship with the voltage requires some fundamental modifications to the basic inverter as discussed below.

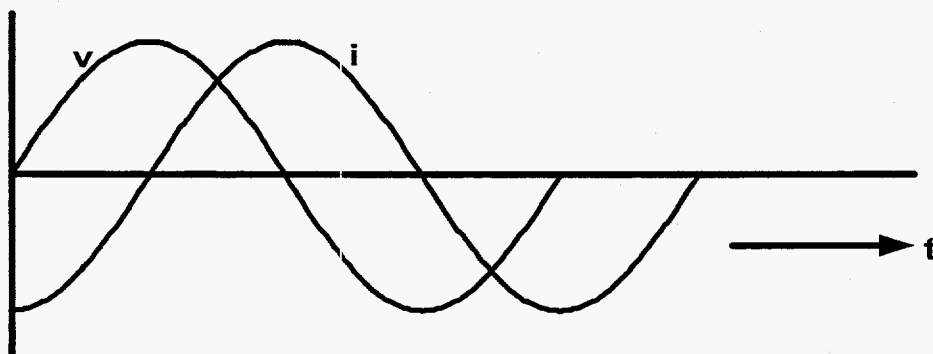

Figure B-3. Voltage (v) and current (i) in a reactive (inductive) load.

Appendix B—Inverters

Accommodating Reactive Loads

To accommodate phase shifts between the AC voltage and current waveforms, the switches in the voltage-source inverter shown in Figure B-1 must be made bidirectional, as indicated by the open-arrow switches in Figure B-4. These bidirectional switches are usually constructed by adding diodes and are also known as back diodes. When the voltage and current in the load are both positive, conduction occurs through the P switches. When the load voltage is negative but the current is positive, conduction occurs through the P' switches. The complete conduction pattern is shown in Figure B-4. Current-source inverters do not require these back diodes. However, if the switch does not have an adequate reverse-voltage rating, series diodes must be used.

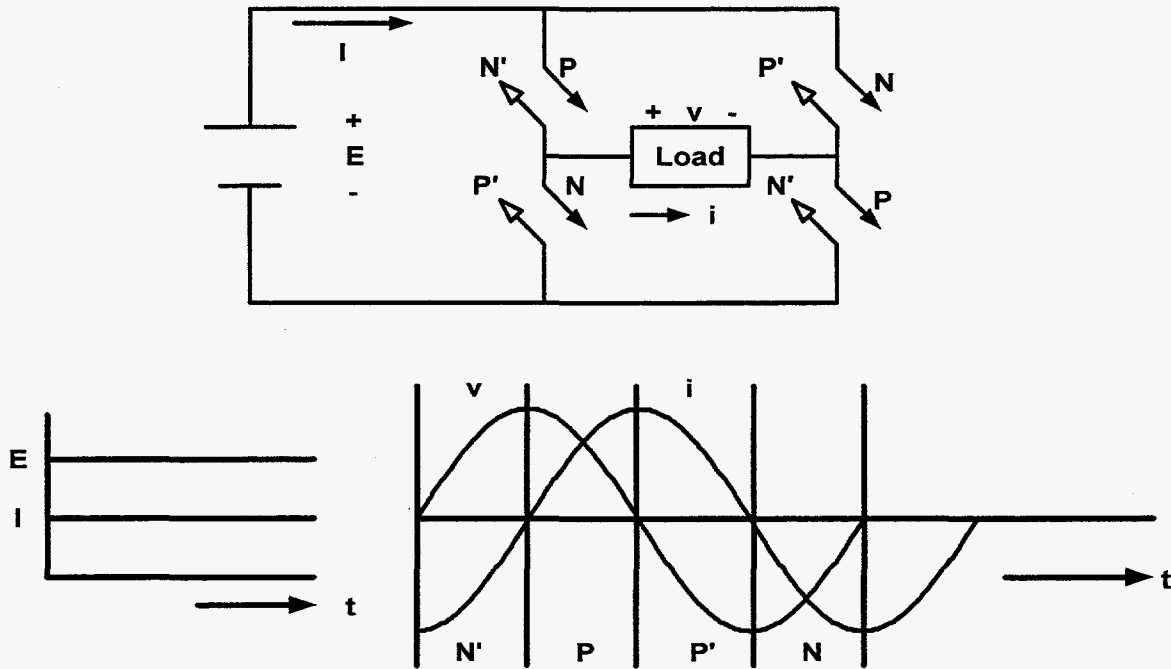

Figure B-4. Accommodating reactive loads.

Using Filters to Modify the Waveform

Another fundamental modification is necessary if the output voltage waveform is sinusoidal (AC) or if the load is not a pure resistor. Kassakian, et al., point out that in this case the instantaneous power from the battery, which is the product of voltage and current, will in general not match the instantaneous load power. If losses are neglected then, in the steady-state, the average power must be equal. Thus, additional filters are necessary to absorb the instantaneous imbalances in battery and load power. The filters can be an integral part of the converter's topology. Generally, these filters are capacitors and inductors. Filters are also applied externally (e.g., at the AC terminals) to control waveform quality.

Waveform Control and Harmonics

In practical applications either the voltage or current, and in some applications both, must be as close to sinusoidal as possible. Consequently, the simple square-wave switching pattern shown in Figure B-2 must be modified. Because the AC voltage and current waveforms in the basic inverter are periodic, the Fourier series and the concept of harmonics provide a useful way to evaluate the distortion in or quality of waveforms with respect to waveforms that are purely sinusoidal.

The square wave current in Figure B-2 can be expressed as the Fourier series shown below:

$$i(t) = I_0 + \sqrt{2}I_1 \cos(2\pi ft + \theta_1) + \sum_{n=2}^{n=\infty} \sqrt{2}I_n \cos(2\pi nft + \theta_n) \quad (B-1)$$

I_0 represents the average or DC component of current. Such a component is not allowed on the AC side because of potential damage to devices such as transformers due to saturation. The second term is the fundamental component of the equation—it represents the desired sinusoidal current. Its frequency, f , is the desired output frequency of the inverter (e.g., 60 Hz). I_1 represents the RMS value of the fundamental component of the current. It has a phase angle of θ_1 with respect to some reference, specifically the fundamental component of voltage. This phase angle affects the real and reactive power supplied.

Each term in the summation is called a harmonic component, or “harmonic.” Harmonics are sinusoidal currents whose frequency is an integer multiple of the fundamental frequency. It has a phase angle of θ_n with respect to the reference. Figure B-5 shows how the fundamental components combine to form the original distorted square waveform.

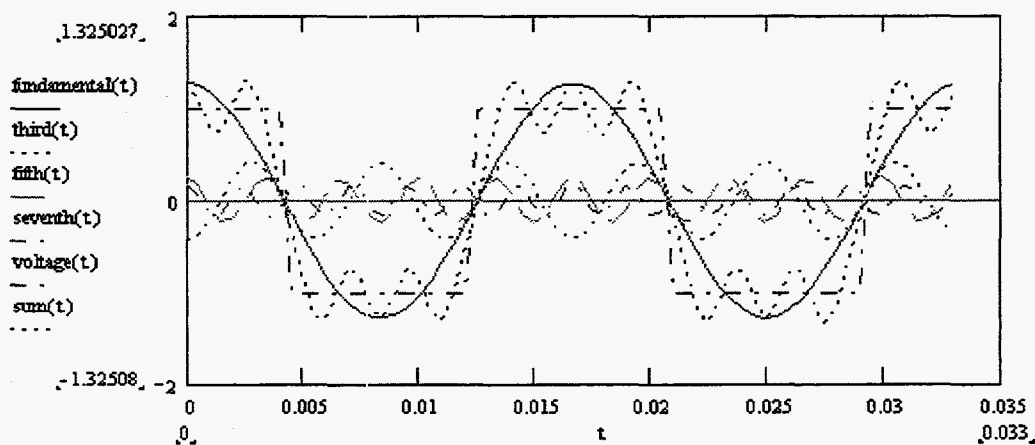

Figure B-5. Illustration of how the fundamental, third, fifth, and seventh harmonic components “sum” to approximate a square wave.

A plot of the harmonic amplitudes (I_0, I_1, I_2, \dots) versus harmonic numbers ($n=0, 1, 2, \dots$) or harmonic frequencies ($f, 2f, 3f, \dots$) is called the amplitude spectrum. The amplitude spectrum of a square wave is shown in Figure B-6.

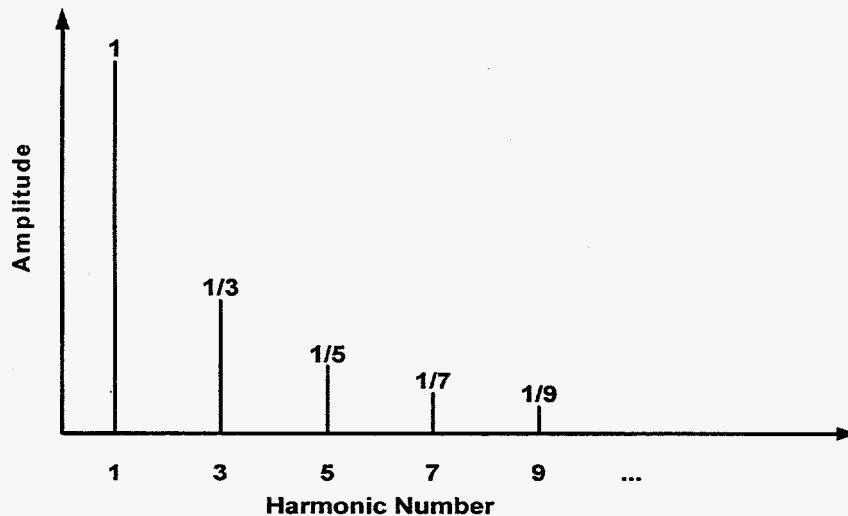

Figure B-6. Harmonic spectrum corresponding to time waveforms in Figure B-5.

In general, harmonic components are undesirable in the inverter output. Harmonic currents propagate into the AC system and can excite resonance conditions, cause excessive heating in components, and cause interference in communication and control circuits. The quality of a periodic distorted waveform is measured by the total harmonic distortion (THD).

$$\text{THD} = \frac{\sqrt{\sum_{n=2}^{\infty} I_n^2}}{I_1} \quad (\text{B-2})$$

Inverters are designed to minimize current and voltage THD. Additionally, specific applications may require that selected harmonics be eliminated. Ideally, the basic inverter does not generate even harmonics. In balanced three-phase systems, harmonics of order $3n$, called “triplens,” are readily eliminated by suitable connections. On the other hand, applications such as active filters require the inverter to synthesize a specific harmonic spectrum. These topics form the area of waveform control.

For example, Figure B-7 shows the basic concept of pulse-width modulation, which is used extensively for waveform control in low-power systems. Switches P and N are turned ON and OFF at regular intervals (eleven times per cycle) to produce the voltage waveform (v) shown. The corresponding waveform for current (i) in an inductive load is also shown. By properly selecting the switching pattern the current can be made to approach a desired waveform.

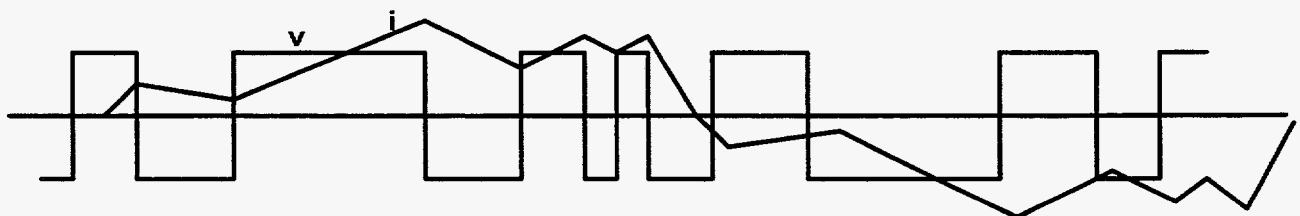

Figure B-7. Pulse-width modulation waveform.

PWM necessitates switching at high frequencies. Device limitations restrict the switching frequency at high power and voltage levels. Therefore, in medium- and high-power systems, low-frequency PWM or stepped-square-wave approaches are used for waveform control. Several phase-shifted low-frequency systems can be combined to achieve higher-frequency operation. Stepped-square-wave techniques similarly use the basic properties of multiphase systems. Typical output waveforms for voltage (v) and current (i) are shown in Figure B-8.

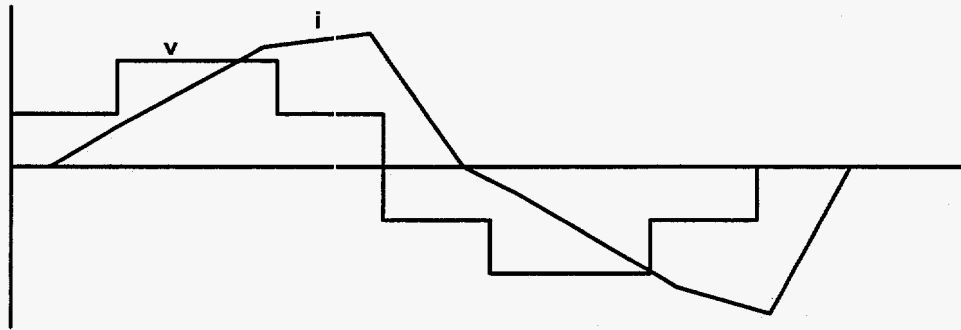

Figure B-8. Stepped square wave.

Waveform synthesis techniques are used to achieve a desired basic spectrum of current. When the inverter is interfaced with a grid, or a load in a grid-independent system, additional restrictions on waveform quality may apply. Harmonic filters can be used as necessary to refine the waveform and accommodate the restrictions. For example, shunt passive filters are resistive-inductive-capacitive (RLC) circuits tuned below desired harmonic frequencies, and provide a low impedance path at harmonic frequencies; series passive filters block the flow of harmonics into the source system; and active filters are, in a sense, inverters designed to generate harmonic currents that cancel existing distortion.

Controlling Output Voltage or Current Amplitude

The fundamental control variables in the operation of the inverter are frequency and output voltage (or current amplitude). For example, PWM varies the width of the pulses to effect amplitude control. In high-power systems, such as stepped-square-wave inverters, changing the input voltage or current effects amplitude control. For the applications described in this report, the frequency is essentially constant or must be regulated to a constant value. In grid-connected applications, transient variations in frequency translate into a phase shift between inverter voltage and grid voltage and are be used to control power and energy flow.

Voltage (or current) amplitude can also be used to regulate power flow from the inverter. In grid-connected applications voltage control results in reactive power changes while current or phase angle control can be used to effect changes in real or reactive power.

Switch Implementation

The simplicity of Figure B-1 belies the fact that each switch can be a complex system in itself. There are several important considerations when choosing the switches for a power electronics device, for example, switch control (turn on/turn off), protection, and loss control/thermal design. These issues are discussed below.

Appendix B—Inverters

Switch Turn-on and Turn-off (Commutation)

Each type of switch has a specific turn-on requirement. SCRs, for example, require a moderate gate current, bipolar transistors require a moderate gate current, and MOSFETs and IGBTs require a small gate voltage. Turn-on driver design involves supplying the requisite current or voltage in a manner that optimizes switching speed and ON-state voltage drop. Switching speed affects switching losses and limits maximum switching frequency. ON-state voltage drop contributes to ON-state power loss in switches. Additional considerations apply when switch terminals float with respect to ground and when a switch is composed of series/parallel connected devices. It is necessary to ensure simultaneous turn-on of devices; and external circuits may be needed to equalize voltage drops and current. In high-power systems there is also an issue of pulse delivery to individual devices; fiber optic systems are used to minimize propagation delay.

Special drivers, implemented in large-scale integration and called power integrated circuits (PICs), are available for MOSFETs and IGBTs. In addition to optimizing turn-on/turn-off these circuits also provide interface and protection functions.

Switch turn-off is generally more complicated because of device and circuit properties. The circuit always contains some inductance. An inductor has the fundamental property that current cannot be interrupted instantaneously. Rapid interruption results in the appearance of high voltages. Thus, practically, whenever a switch is turned OFF an alternate path must exist to maintain current flow in inductors in the circuit. Thus, during turn-off current is diverted from one path to another. This transfer of current is called commutation.

Turn-off design depends on the type of switch used. SCRs are turned OFF by reducing their current to zero and reverse biasing them for a period of time. Thus, a reverse biasing voltage must be available. The reverse biasing voltage can be provided in a number of ways including grid or load voltage sources or by additional circuits. GTOs require a significant negative gate current. Bipolar transistors, IGBTs, and MOSFETs require a moderate negative current or voltage. The PICs referred to previously also provide functions for optimized turn-off of MOSFETs and IGBTs.

In literature, the following terms are used to describe common types of switch commutation:

- **Line-commutated**—refers to switches where turn-off is achieved by turning a switch on in an alternate path with reverse bias provided by a voltage source from a grid.
- **Force-commutated**—refers to switches where external circuits are used to reverse bias and drive current to zero in the switch that is being turned OFF.
- **Self-commutated**—refers to switches that can be turned OFF by gate or base drives within the switch itself.
- **Load-commutated**—refers to switches turned OFF either by loads that provide reverse biasing voltages, or resonant inductive-capacitive (LC) circuits that cause natural current zeros.
- **Lossless**—also called zero voltage/zero current switching (ZVS/ZCS), refers to circuits that permit switches to turn ON and/or OFF only when current/voltage is zero, thereby eliminating switching losses.

Switch Protection

The semiconductor switches in the inverter must be protected from overvoltages, overcurrents, and fast rates-of-rise of voltage and current. The current-source inverter is inherently protected against overcurrent. Overcurrent protection in SCR-based circuits is often provided by semiconductor fuses. In modern circuits that utilize MOSFETs and IGBTs, current sensors can be used to provide protection. There is no simple way to protect against overvoltages. Generally transient overvoltages are reduced using surge protection and snubbers, and power devices are rated to withstand anticipated sustained overvoltages.

Snubber circuits, such as the one shown in Figure B-9, provide protection from rapid rates-of-rise of voltage and current. A capacitor mutes the voltage rate-of-rise and the inductor limits the current rate-of-rise. As a side benefit, optimized snubbers can reduce switching losses. Additionally, the switching transient can be modified in a way such that some of the switching loss occurs in the snubber rather than in the semiconductor device. This is preferred since snubber components are more robust and, consequently, are better equipped to handle switching losses.

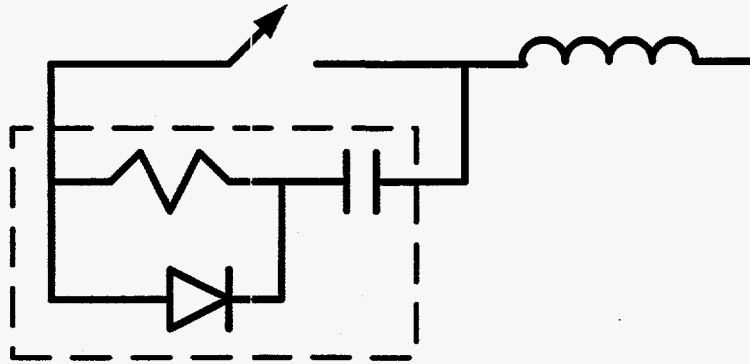

Figure B-9. Snubber circuit.

Loss Control

Power losses in the switch are important both because of efficiency and cooling considerations. The losses can be segregated into three components: switching loss in the device, ON-state loss in the device, and snubber loss. ON-state losses dominate in circuits that switch at low frequency, while switching losses in the device, which occur once for every switch transition, are dominant in high frequency switches. Optimized drivers and snubbers can reduce each component of loss. Conventional switching is usually called hard switching.

A fundamentally different approach—soft switching—involves zero-voltage and/or zero-current switching. The idea here is that during switching, either the voltage or the current is maintained at zero value. This eliminates switching losses, which results in significant benefits at high frequencies. Additionally, this approach significantly reduces electromagnetic emissions. However this benefit is often achieved at the expense of higher device ratings and additional circuit components. ZVS/ZCS is achieved using resonant circuits and the peak value of resonant voltage or current exceeds DC bus voltage or current.

Appendix B—Inverters

Soft-switching uses three basic approaches. In resonant-switch or resonant-pole designs, additional circuits are placed across the switch to ensure ZCS/ZVS. In resonant-load commutation, the load comprises a resonant circuit and ensures current zeros where the switches are turned OFF; another type of resonant-load commutation uses a resonant DC link in place of the ideal voltage or current source to provide instances of ZCS/ZVS where switches are turned OFF. Finally, the cascade switching approach uses additional switches to reduce stress on the main switch, but the applications of this approach have been limited to DC-to-DC power supplies. Cascade switching utilizes additional semiconductor devices to enhance turn-off of the main device.

Inverter Ratings

The nameplate rating of an inverter is not a standardized quantity (unlike ratings for other equipment such as motors and generators). Inverters can be described by the nominal input DC voltage and current, and by the nominal output voltage, current, kVA (kilovolt-amperes—the product of voltage and current), and power factor.

The appropriate ratings for semiconductor devices and ancillary circuits used in a particular design are determined by the nameplate parameters, the chosen inverter topology, and the control requirements. These, in turn, determine the overall cost and footprint of the inverter.

Consider the basic grid-connected, square-wave inverter shown in Figure B-1. Assuming that at least one pair of devices (P or N) is in conduction at any time, the maximum voltage across a device is the peak AC voltage. This mode is called “continuous conduction mode” because the current only goes to zero at the natural zero crossings of the AC current. In discontinuous conduction modes, which are rarely used in inverters with significant ratings, there may be periods of time when more than two devices are OFF and the AC current is zero. In these instances, the device voltage can be as high as twice the peak AC voltage. The average current in each device is half the DC current and the RMS current is 70% of the DC current when the AC current and voltage are in phase. It is common to build in a 25% margin on both current and voltage ratings.

If cost-effective devices are not available in the requisite ratings, then one of two approaches can be followed. In the first approach each device is constructed as a series/parallel arrangement of available devices. An extra device is used to ensure reliability. The cost rises sharply since additional circuits or controls are needed to balance voltages across and current through devices. The second, or modular, approach is based on series-parallel connections of inverters. The control algorithm is designed to ensure current/voltage sharing between inverters.

Component Ratings

Component ratings are affected by several factors. These factors can be classified as requirements-related, system-related, and topology-related.

Requirements-related Factors

Grid-independent and hybrid systems may require a moderate ability to handle surges in required current or power, for example during motor starting. Since semiconductor devices have no inherent overload capability, surge capability is obtained by using larger devices.

The energy storage system, e.g., a battery bank, also determines practical DC input voltage. Often this voltage is low, typically 600 V, and this sets the requirement for device current ratings. For example, IGBTs of voltage ratings substantially larger than 600 V are available and the available current ratings may be adequate for an application. However, the lower input voltage demands a higher current, which in turn may dictate an oversized device or device paralleling.

System-related Factors

Walker has provided an interesting formula for inverter rating in a battery energy storage application. Although target applications are SCR-based inverters, we suspect the formula is approximately valid for all inverters. Walker's formula is given below:

$$\frac{SA}{SB} = \left(1 + \frac{E_{\max}}{E_{\min}}\right) \left(1 + \frac{V_{\max}}{V_{\min}}\right) \left(1 + \frac{UBF}{X}\right) (1 + KVAR * X) \quad (B-3)$$

SB denotes the basic kVA rating discussed earlier and SA the actual rating required. The first term relates to variations in the input DC voltage. The inverter must be sized for the maximum DC voltage (E_{\max}) and the maximum current, which will occur when the input voltage is at a minimum (E_{\min}). The second term similarly relates to voltage variations V_{\min} to V_{\max} from the AC source. The third term is important in a three-phase system. Ideally, such systems are balanced with equal voltage and current magnitudes in each phase and a phase displacement of 120° between phases. If, however, there is an unbalance, measured by the unbalance factor (UBF), then device currents and voltages will differ from each other; each device must be able to withstand maximum voltage and current. The final term relates to the need to supply reactive power (kVAR) to a power system represented by an equivalent reactance, X.

The significance of Walker's formula is that when an inverter is designed to operate over wide ranges of input and output parameters, the required rating and cost increase dramatically. A tradeoff thus exists between adding stages, for example a DC preregulator to change a varying battery voltage to a constant DC voltage, or designing the inverter for variable input voltage.

Topology-related Factors

Basic component ratings apply only to the simple square-wave inverter. More advanced switching strategies require an increase in ratings as discussed below.

Appendix B—Inverters

Pulse-width Modulation

Recall that PWM is widely used for waveform control. The use of PWM increases switching losses in devices. This loss is proportional to switching frequency. Thus the cost of device cooling increases. Alternatively a higher-rated device can be used.

The use of higher switching frequency reduces size of magnetic components. Inductors and transformers have ferromagnetic cores that can achieve higher magnetic flux densities at relatively low current levels. There is, however, an upper limit on the magnetic flux density in ferromagnetic components because of the physical properties of saturation and magnetic losses. The size of a magnetic component is determined by the magnetic flux requirements. A larger flux requires a larger cross sectional area to limit the flux density to levels allowed by the ferromagnetic material. The flux, in turn, is determined by the voltage or current in the component. Where voltage is the determining factor, the flux is inversely proportional to frequency. In this instance, a higher frequency reduces the flux requirements, and therefore magnetic device size. This idea is often exploited in systems that use transformers for isolation.

However, particularly relevant to the size of systems of interest in this report, inductors and capacitors do set a limit to switching frequency. Magnetic losses increase with frequency; losses in capacitors also increase. At the same time, increases in AC resistance reduce the quality factor for inductors and capacitors.

Stepped Square Wave

Another technique for waveform control is to use series-parallel combinations of low-frequency switched inverters with appropriate phase shifts or staggering, the stepped-square-wave approach. Conventional approaches add to cost since they necessitate the use of transformers for phase shifting. Multilevel converters using the stepped-square-wave approach for waveform control are relatively new topologies that minimize the use of transformers, which in turn can decrease the overall cost.

ZVS/ZCS-type Topology

As indicated previously, these topologies seek to minimize and eliminate switching losses by ensuring that the voltage across a device or the current through the device is zero during the switching period. The topologies achieve this function by additional resonant (LC) circuits. These resonant circuits generally subject the device to a higher voltage in the OFF state and/or a higher current in the ON state. Thus device ratings must be higher. In the simplest ZVS/ZCS type circuits the devices may have to be overrated by a factor of two.

Bidirectional Conversion

In ESS applications it is often convenient to think of available direction of flow for real power and for reactive power, or “quadrants” of operation as illustrated in Figure B-10. In typical applications, transfer of real power from the DC to the AC side is often called powering, or discharging, in ESS applications. Transfer of real power from the AC to the DC side generically corresponds to rectification and is also called regeneration or charging. Assuming the powering mode, the inverter is operating at leading power factor if it supplies

reactive power and lagging if it absorbs reactive power. In ESS applications, both multi-quadrant capability and the range of operation in each quadrant are important.

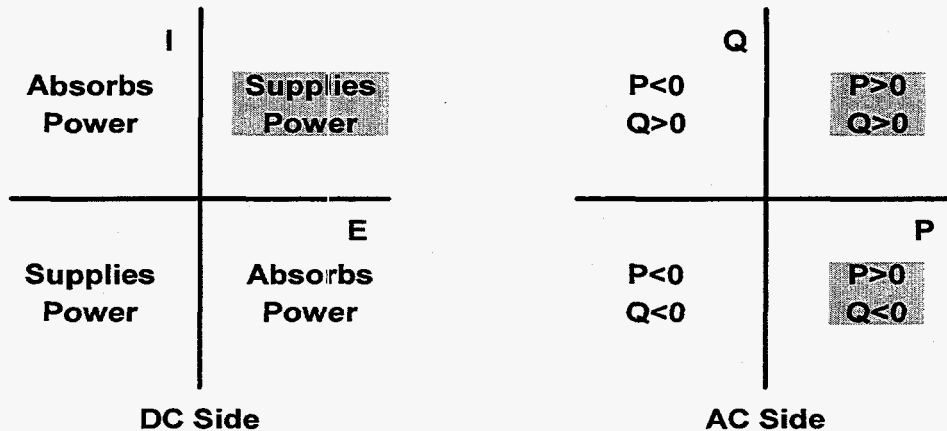

Figure B-10. Operating quadrants for a basic current-source inverter.

In the basic current-source inverter, the battery voltage is unidirectional and is always positive. Further, the current out of the battery is always positive because of the unidirectional nature of the switches. Thus, the battery always supplies energy and the real power output is always positive. With force commutation, the phase angle of the square-wave AC current can be adjusted so as to lead or lag the AC voltage and thus absorb or supply reactive power. The operating quadrants of the inverter are shown as shaded areas in Figure B-10.

The voltage-source inverter, on the other hand, is inherently bidirectional and can operate in all four quadrants. As a trivial example, if the main switches are not turned ON at all the back diodes act as a bridge rectifier. However, in basic topologies the range of operation is limited by the relative magnitudes of the DC and AC source voltage. One approach for overcoming this limitation is to use multiple conversion stages.

Interface with Utility or Load

Figure B-11 illustrates how inverter building blocks might be used for a specific application. In a SMES- or battery-based grid voltage regulation application, it may be adequate for the system to provide reactive power as needed to maintain voltages. In this case, the ESS may be interfaced through the DC side of an inverter. A DC-to-DC converter may be used, at additional cost, to either provide charge/discharge control or to optimize operating conditions for the inverter. All converters must be bidirectional. It should be emphasized, however, that many alternative building block combinations may provide the requisite interface. A range of commercially available topologies is provided in the body of the report.

Appendix B—Inverters

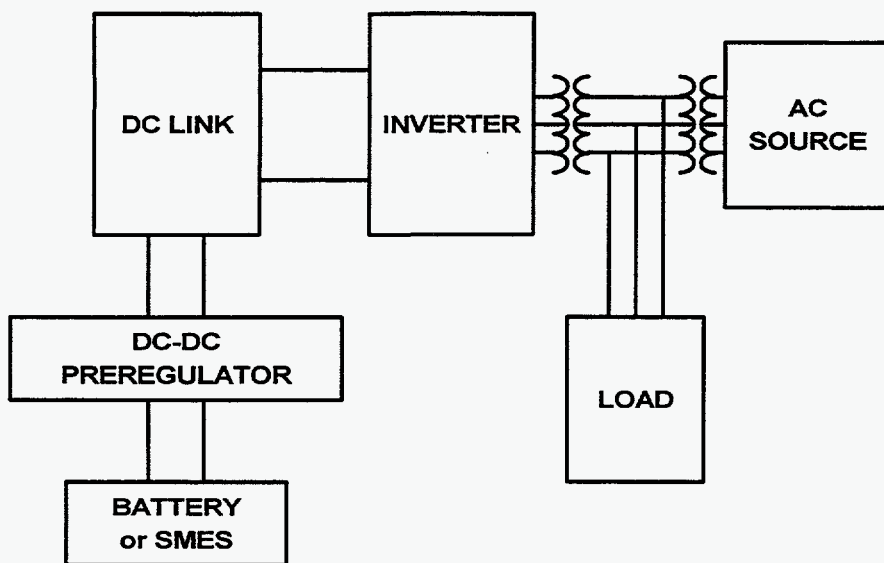

Figure B-11. Voltage regulation building blocks.

In Figure B-11 the inverter is simply designed to be a source of AC energy in parallel with the power system. As such it may be called a “parallel” or “shunt” connection. The voltage rating of the inverter matches that of the power system, while the current rating depends on the change in current or power that the inverter must effect. It is, however, easy to imagine an application in which the inverter and ESS might be used simply to provide a voltage magnitude through a series connection as shown in Figure B-12. In this connection, the inverter or its balance of system must accommodate the entire load current but the voltage rating would depend only on the boost required.

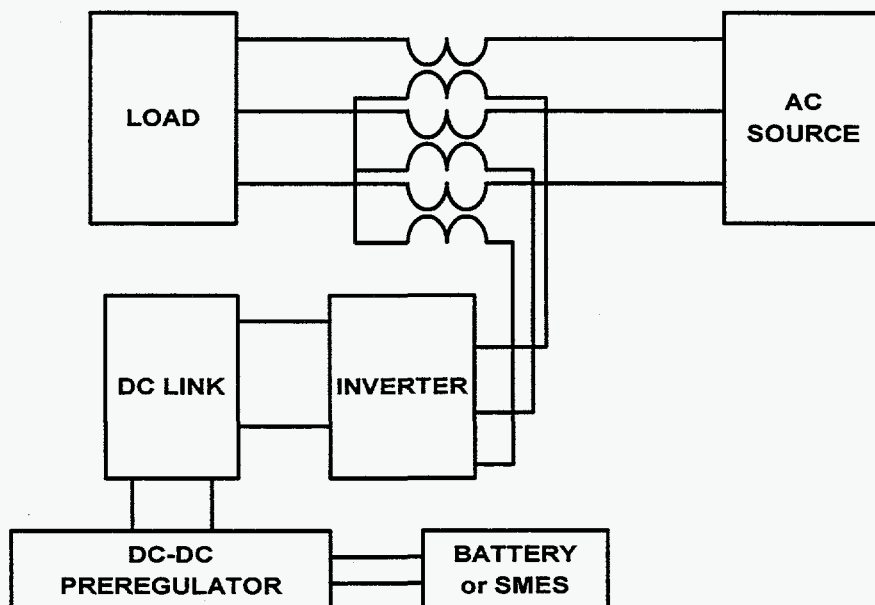

Figure B-12. Series-connected voltage boost inverter.

The Unified Power Flow Controller, which belongs to the Flexible AC Transmission System (FACTS) device family, has the general series/shunt structure shown in Figure B-13.

The DC link is usually simply a capacitor, but could well be an ESS. The device can be controlled to draw real power from either shunt or series connections. Similarly, it can inject (reactive) power through the shunt connection or modify voltage amplitude and phase through the series connection.

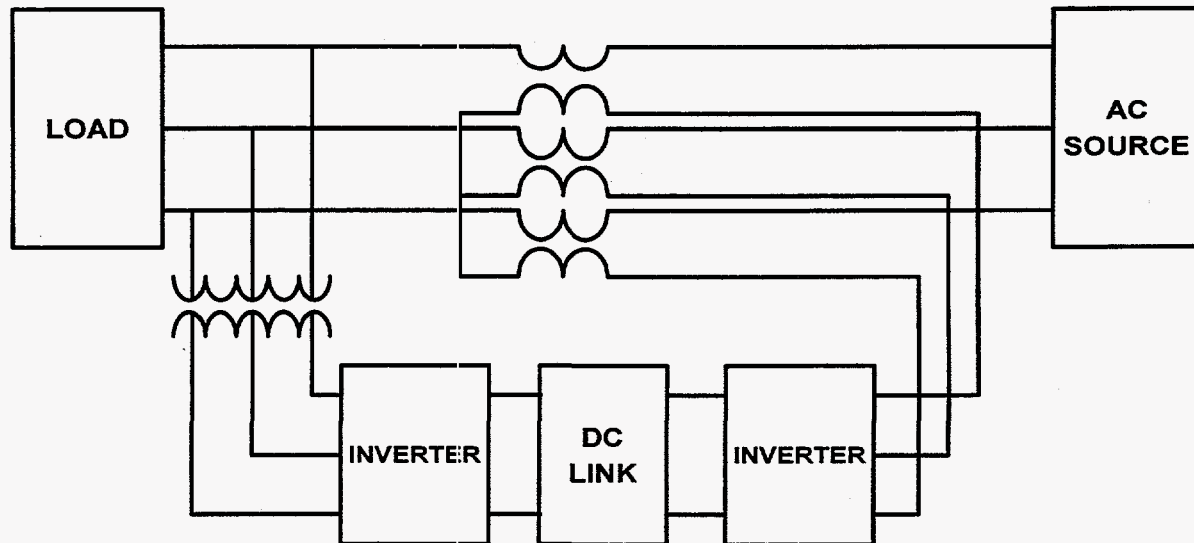

Figure B-13. Unified Power Flow Controller.

Commercially available topologies favor the type of connection shown in Figure B-11 and a range of such topologies is discussed in the body of the report.

Three-phase Inverters

Electric power systems are operated as three-phase systems. From the distribution level up, the systems are essentially balanced. In a balanced three-phase system the voltage magnitudes are equal in each phase (a, b, and c) and there is a 120° phase shift between these voltages; currents have the same property. Balanced three-phase (passive) loads refer to three equal wye- (Y) or delta- (Δ) connected impedances.

The basic single-phase bridge inverter is readily extended to produce three-phase voltages for a voltage source inverter by adding another “leg” as shown in Figure B-14. Back diodes are required but are omitted in the figure for clarity. A resistive balanced load is assumed. The switching sequence is shown in Figure B-15, and produces the rectangular wave pattern shown by the line-line voltages v_{ab} , v_{bc} , v_{ca} . Superimposed on these rectangular waves, the dashed waveforms represent the fundamental (sinusoidal) components of the line-line voltages. Other switching schemes including PWM can also be used. The ZVS/ZCS schemes are also readily applied to three-phase systems.

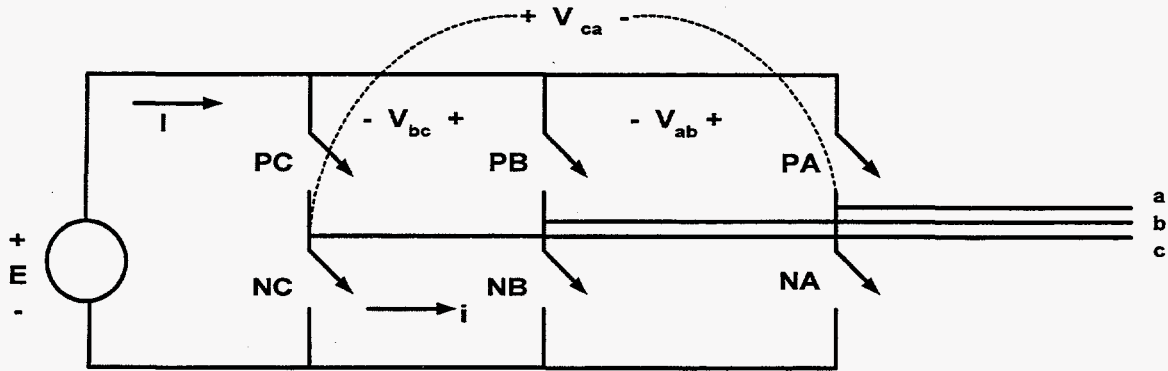

Figure B-14. Three-phase voltage-source inverter.

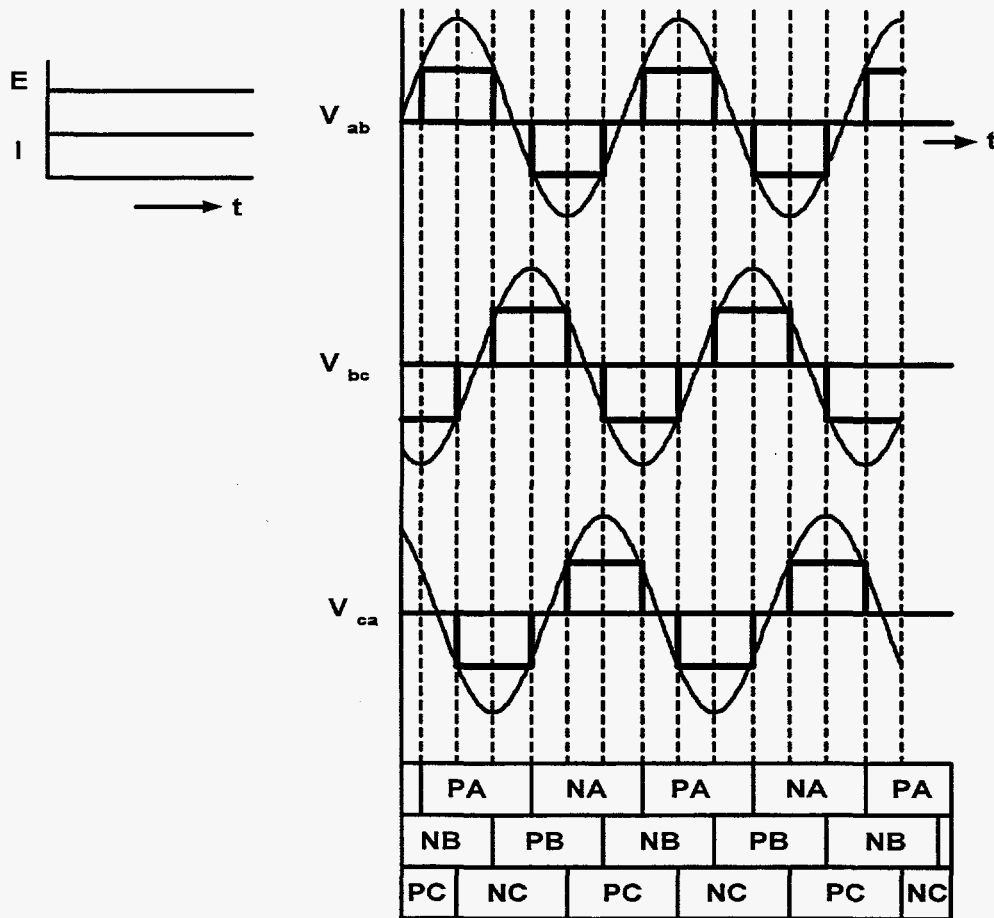

Figure B-15. Waveform and switching sequence for a three-phase, voltage-source inverter.

Matrix Converters

Previous sections have discussed the basic concepts associated with single- and three-phase inverters. This section summarizes another topology, the matrix converter, which allows transformation from a multiphase system at one frequency (possibly DC) to another multiphase system at a different frequency and possibly with a different number of phases.

The conceptual topology is shown in Figure B-16. In this diagram, the first three-phase system is connected to three lines or columns of the matrix. The second three-phase system is connected to the rows. Bilateral switches, (i.e., switches that can conduct in either direction when an appropriate control signal is applied) connect each row to each column. The switches are denoted as “ S_{ij} ” where $i = A,B,C$ and $j = a,b,c$. Thus, “ S_{Aa} ” is the switch connecting Phase A of the first system to Phase a of the second.

One way to operate the converter is to turn switches ON and OFF at a specific frequency for period T . A switch is ON during some portion dT of the period T . Assume the first system supplies balanced voltages to the terminals ABC , and that the second system is a resistive load. If switches S_{Ab} and S_{Bc} are closed, the voltage V_{bc} instantaneously equals V_{AB} . Over the switching period the local average value of V_{bc} is dV_{AB} . The state of the switches thus determines the voltage across the load. The idea, then, is to determine a switching function that will produce the desired waveform at the load; this determination is the basic idea behind the concept of space-vector modulation. This idea is extensively used in cycloconverters. “A cycloconverter is a frequency changer that converts AC input power at one frequency to output power at a different frequency with one-stage conversion.” (Bose)

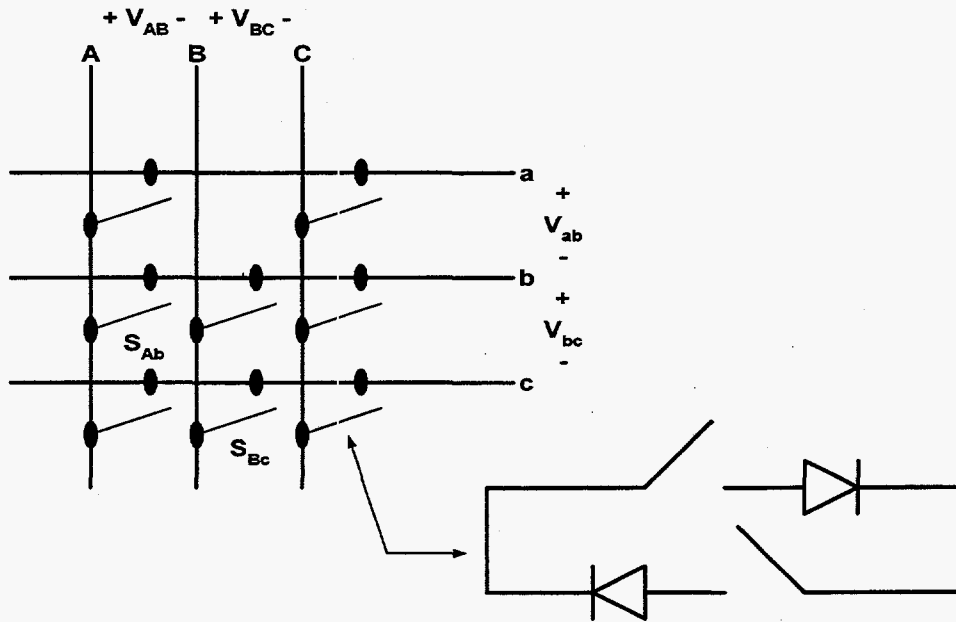

Figure B-16. Matrix converter.

Specific Converters

This section describes some specific and practical converter circuits that can be used in conversion applications.

Line-commutated Converters

Line-commutated converters have been widely used in power systems and in motor control for over three decades. In very high-power utility applications (100 MW and larger) thyristor-based converters of this type are still the only available topology.

Circuits for single-phase and three-phase line-commutated converters are shown in Figure B-17. In the single-phase circuit, the source (E) is a DC source and the source (V) is an AC source. The switches are SCRs. The “P” SCRs are turned ON during the positive half-cycle of the AC voltage, while the “N” SCRs are turned ON at a corresponding point in the negative half-cycle. The firing is delayed with respect to the zero crossing of the AC voltage by an amount known as the firing angle. Figure B-18 shows waveforms for inverter operation with a firing angle greater than 90° . In this case, the average value of the voltage (v_d) is negative; if its magnitude is less than E , a direct current (i_d) is established in the inductor. If the current is continuous, a conducting SCR pair (e.g., P, P) continues to conduct until the next one is switched ON and the cycle repeats. The turn-off of the first SCR pair is facilitated by the AC voltage source providing a reverse bias and the incoming pair picking up the current—hence the name line-commutation. The AC current is approximately a square wave. Under these conditions, power is delivered from the DC source to the AC source. If the polarity of the DC source is reversed and the firing angle is less than 90° , the circuit acts as a rectifier.

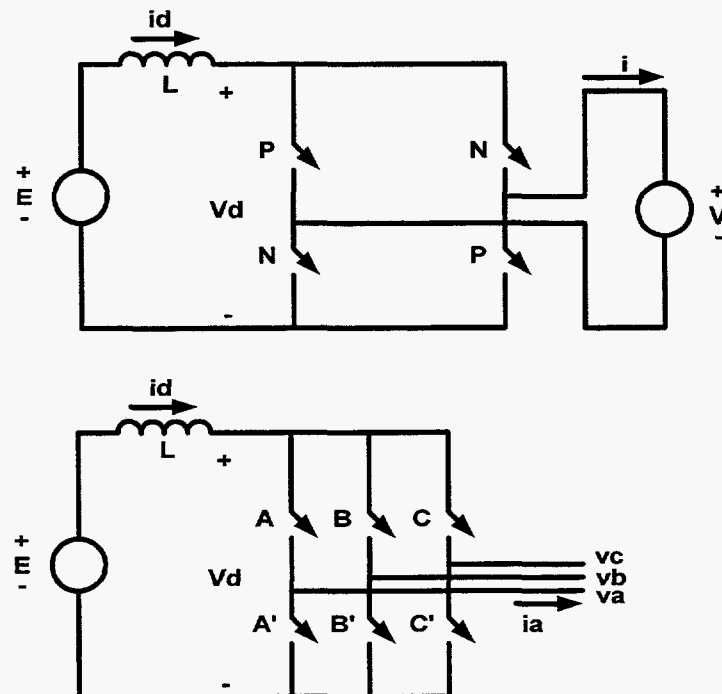

Figure B-17. Single- and three-phase line-commutated converters.

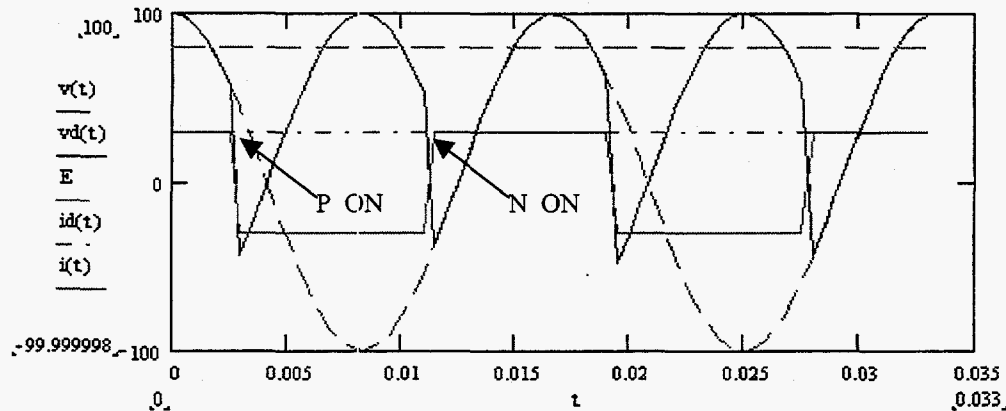

Figure B-18. Voltage and current waveforms for a single-phase, line-commutated converter.

The three-phase version of a line-commutated converter is also shown in Figure B-17. The waveforms for this circuit operating as a rectifier (AC to DC) are shown in Figure B-19. The DC voltage (v_d) contains six pulses per AC cycle and thus is called a six-pulse bridge.

A comparison of the voltage and current waveforms for the single-phase converter (Figure B-18) with those for the three-phase, six-pulse bridge (Figure B-19) shows that on the DC side, the voltage ripple ($v_d(t)$) has been substantially reduced. On the AC side, the current waveform for the six-pulse bridge still consists of a rectangular pulse, but this waveform has a special property—it does not contain triplen harmonics (i.e., harmonics whose frequencies are multiples of three times the fundamental frequency). In this sense the bridge rectifier, or bridge converter, has a better waveform quality and thus a reduced filtering requirement.

The improvement of waveform quality in the six-pulse bridge is obtained because the three input AC voltages comprising the three-phase source are 120° apart in phase. Thus, their contributions to the waveforms are staggered with respect to each other. This principle can be extended to higher-pulse-order converters by using additional phase-shifted voltage. For example, a twelve-pulse bridge can be constructed using six voltages that are 60° apart in phase. Another way to obtain higher pulse order is to use series (or parallel) connection of bridges. Each bridge is fed from a three-phase source in which each phase is appropriately shifted with respect to the other phases. In a series connection, the bridge voltages sum to provide the total DC voltage. The requisite phase shift is obtained by changing the connections of the transformer feeding each bridge. The connection of a twelve-pulse bridge is shown in Figure B-20.

Appendix B—Inverters

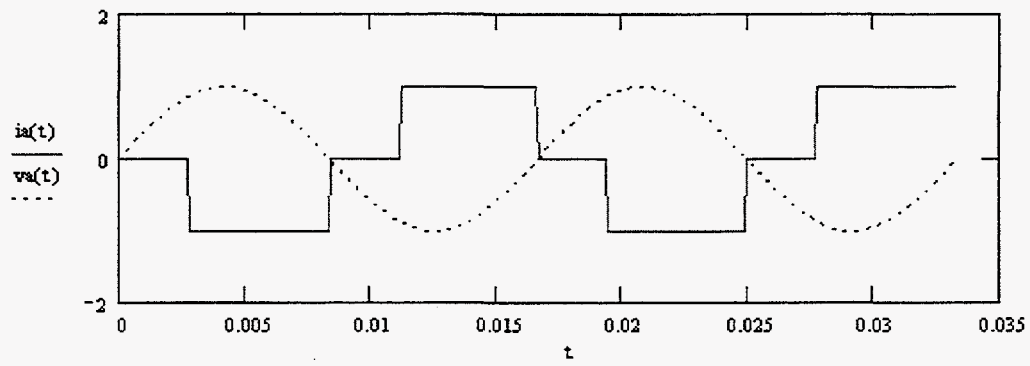
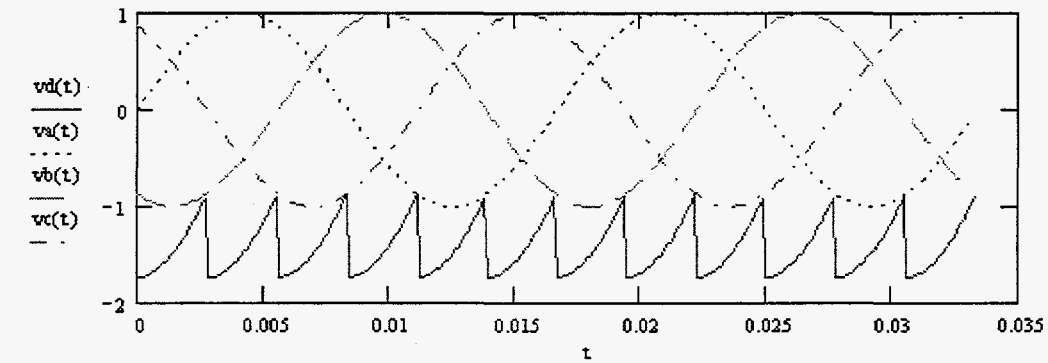

Figure B-19. Waveforms for a three-phase, six-pulse bridge rectifier.

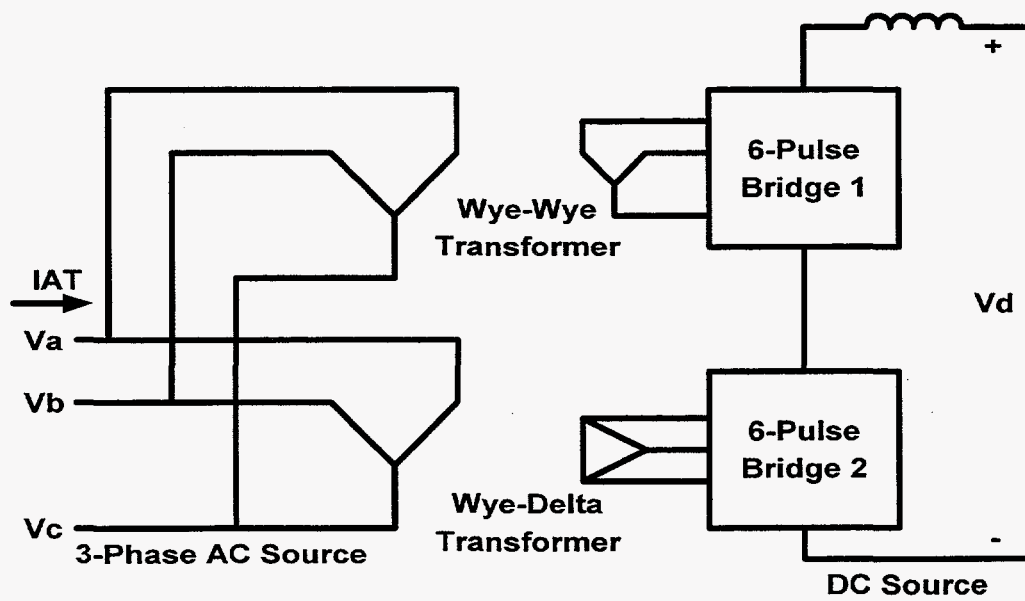

Figure B-20. Twelve-pulse bridge using wye-to-wye and wye-to-delta transformers.

In Figure B-20, Bridge 1 is fed from the AC source via a wye-to-wye transformer (i.e., a three-phase transformer in which the primary and secondary windings are each connected in a wye-connection, as shown). Bridge 2 is fed from the AC source via a wye-to-delta transformer. The voltages input to Bridge 2 are phase shifted by 30° with respect to the voltages input to Bridge 1. The waveforms for a twelve-pulse bridge consisting of two series-connected bridges with input AC voltages shifted by 30° are shown in Figure B-21. Again, the effect of the staggered voltage and current contributions can be seen. The DC voltage now has a smaller-amplitude, and higher-frequency ripple. The AC current waveform is now a stepped square wave. The waveforms for a twelve-pulse bridge have a lower harmonic content with respect to the corresponding waveforms for the six-pulse bridge. In general in a p -pulse arrangement, the AC current harmonics are restricted to $np \pm 1$, where $n=1, 2, 3$, etc. The AC current harmonics in a twelve-pulse bridge ($p=12$) are thus limited to 11, 13, 21, 23, etc.

Although discussed in the context of line-commutated converters, the concept of using transformers for phase-shifted series or parallel operation is applicable to all converters discussed in this appendix.

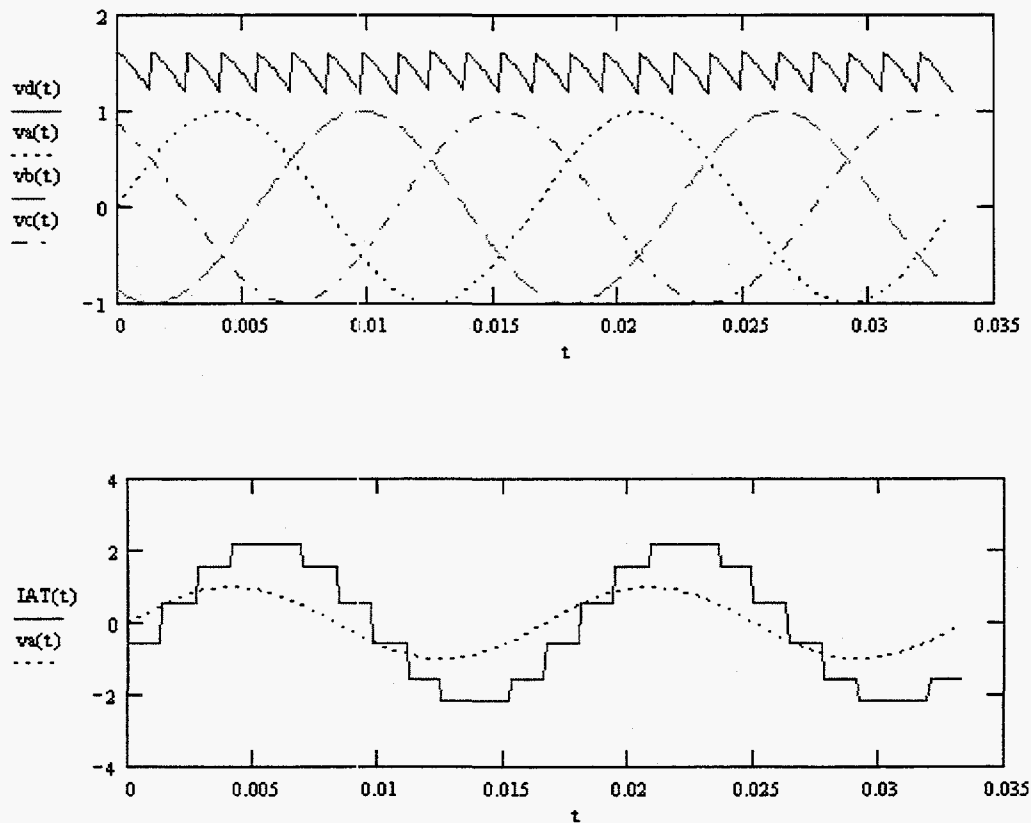

Figure B-21. Waveforms for a twelve-pulse bridge inverter.

Appendix B—Inverters

Although simple and suitable for very-high-power applications, line-commutated converters have several disadvantages as summarized below.

- Generally, an AC voltage source is necessary; thus the inverter is not suitable for grid-independent applications.
- The circuit always absorbs reactive power; consequently, it cannot be used for reactive power regulation except in conjunction with external capacitors.
- Low-frequency operation and stepped-square-wave current require extensive filtering of AC-side harmonics.
- Specific current waveforms cannot be synthesized.

Force- and Self-commutated, Hard-switched Converters

The line-commutated converter generally requires an AC source and absorbs reactive power. Switch turn-off is predicated upon an alternate current path being provided by the natural reversal of AC voltage, which allows the turning ON of alternate switches and reverse biasing of the conducting switches. If the switches in the inverter can be turned OFF when desired, then the inverter can operate with or without an AC source. Alternative paths for current may still have to be provided (e.g., by the back diodes). Further, the amplitude and phase of voltage and/or current can be adjusted to provide, in principle, four-quadrant operation.

The term force-commutation is generally applied to SCR-based circuits in which additional or external circuits are used to force the turn-off of a desired SCR. Such circuits have been used in the 0.5- to 10-MW range in SCR-based motor controllers operating at frequencies up to 300 Hz. The term self-commutation is used somewhat ambiguously, but generally refers to the use of switches such as BJTs, MOSFETs, IGBTs, and GTOs/MTOs which can be turned OFF by a drive signal. The low-power range, up to approximately 500 kW, now almost exclusively uses IGBTs with switching frequencies in the 500- to 2000-Hz range. GTO-based reactive power controllers with switching frequencies of 300 to 800 Hz have been installed at power levels of 30 to 50 MW.

Force- and self-commutated converters inverters can either be voltage- or current-source with the former being the most versatile. Voltage-source inverters use a series inductor or an LC filter at the AC voltage output for filtering the current waveform. Current-source inverters generally use a large shunt capacitor at the AC output as a filter.

Force- and self-commutated converters, as described above, are also called hard-switched converters. Hard-switching converters generally experience a degree of switching loss because, for a short duration during turn-off and turn-on, switch voltage and current are both greater than zero which causes energy dissipation in the switch. The corresponding power loss is directly proportional to switching frequency. These losses degrade efficiency and increase cooling requirements. The point where switching losses begin to dominate is probably at switching frequencies of about 8 to 10 kHz. Additionally, hard switching generates radiated- and conducted-EMI, which must be controlled by in-line filters and shielding/packaging, respectively. Finally, the switching frequency tends to be within the audio range.

The ability to commute switches also allows the use of the stepped and PWM techniques mentioned earlier for waveform control. This in turn reduces filtering requirements compared to line-commutated converters.

Soft-Switching

Soft-switching techniques were developed to overcome the fundamental limitations on switching frequency that derive from loss considerations in hard-switched converters. The basic idea is to use additional circuit components, usually resonant circuits, in a way that ensures that voltage or current is held at zero during switching intervals, thus eliminating the switching loss.

Snubbers, described earlier, tend to reduce the rate-of-rise of voltage/current and thus reduce loss in the switch; however, losses now occur in the snubber itself. Resonant snubbers were developed to minimize losses, and were further developed to hold switch voltage at zero during turn-off. Resonant converters, typically the so-called "load-resonant converters," have been developed for DC-to-DC conversion wherein an LC circuit is used to force zero-crossings where switches are turned ON or OFF.

The resonant DC link concept was developed by Divan and has gained wide acceptance. This circuit will be briefly, if somewhat simplistically, described here to summarize the basic ideas of soft switching. The original version of the circuit is shown in Figure B-22.

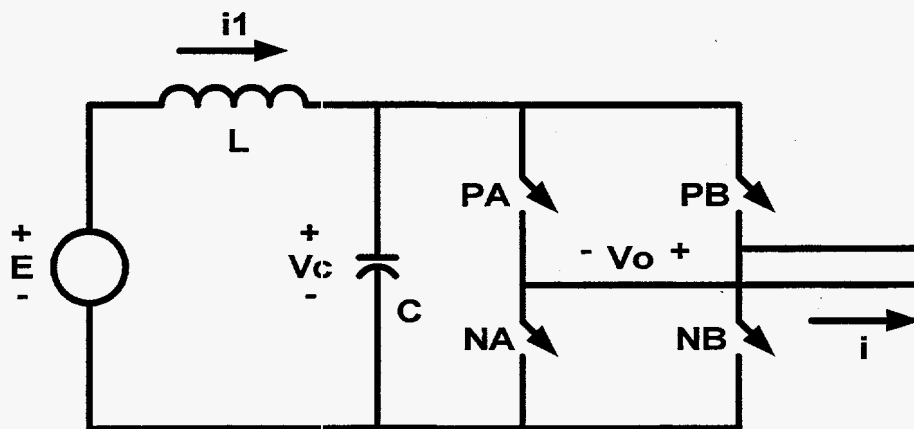

Figure B-22. Basic DC-link soft-switching inverter.

Suppose at a given instant appropriate switches are ON so as to short-circuit the capacitor. The inductor current I_1 will then rise. If the switches are now turned OFF, the capacitor maintains essentially zero voltage during the short turn-off period. Thus the switches turn OFF with zero loss. Suppose now, at this point, switches PA and NB are ON, to supply current to the load in a manner similar to the basic single-phase inverter. If the inductor current is sufficiently larger than the current delivered to the load, excess current is forced into the capacitor, essentially establishing a resonant oscillation. The capacitor now charges and then discharges to zero volts, provided that the original inductor current is sufficiently large. The switching of devices can now be organized to again short the capacitor and maintain the voltage V_c at zero volts for short period of time. Lossless switching can again be performed and the cycle repeated.

Although the switching scheme is now more complicated, it is seen that switching can be organized so as to obtain the waveform of DC bus voltage V_c as shown in Figure B-23. Given this waveform, strategies such as pulse density modulation (PDM) can be used to synthesize an AC voltage v_0 . As illustrated in Figure B-23, switches PA and NB are

Appendix B—Inverters

switched ON and OFF under zero-voltage conditions to generate discrete positive-voltage pulses in the first half-cycle of output voltage, then the second half-cycle is synthesized using switches NA and PB. This strategy is called discrete pulse modulation.

The basic circuit discussed here eliminates switching losses, which permits higher frequency switching. The circuit has the disadvantage of requiring much higher voltage and current ratings for the switches because the switches must carry resonant components of voltage and current. Equally important limitations are the complexity of control and the lack of true PWM capability. Substantial research in this area has led to modifications that have essentially removed the high rating requirement limitation, and control schemes have been developed that approach true PWM.

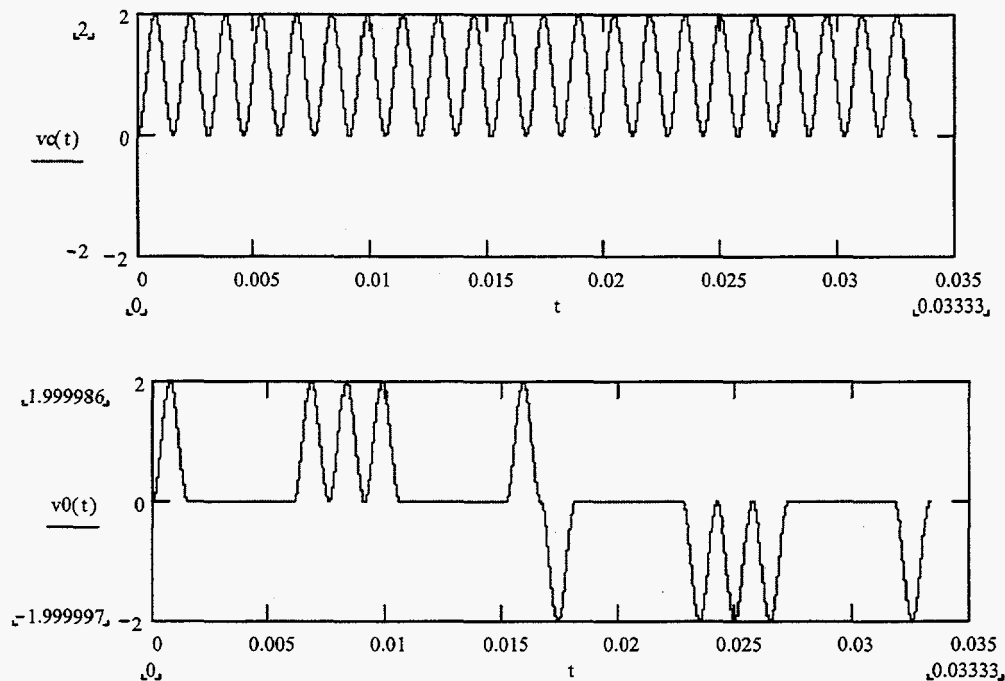

Figure B-23. Representative DC-link inverter waveforms under discrete pulse modulation.

Multilevel Converters

The converters discussed so far find application in well-defined power/voltage ranges primarily because of the capabilities of the devices used and secondarily by interface requirements. The line-commutated converter using SCRs is suitable for the high power range, but requires complicated transformer arrangements and filters for waveform control. GTO-based voltage-source inverters can also be built at high power levels, but switching frequency limitations require extensive filtering. The higher-frequency hard- and soft-switched converters are limited to the lower power/voltage range. Multilevel converters were developed to overcome some of these limitations. Figure B-24 shows the structure of a single-phase, three-level voltage-source inverter, while Figure B-25 shows the structure of a single-phase, three-level current-source inverter.

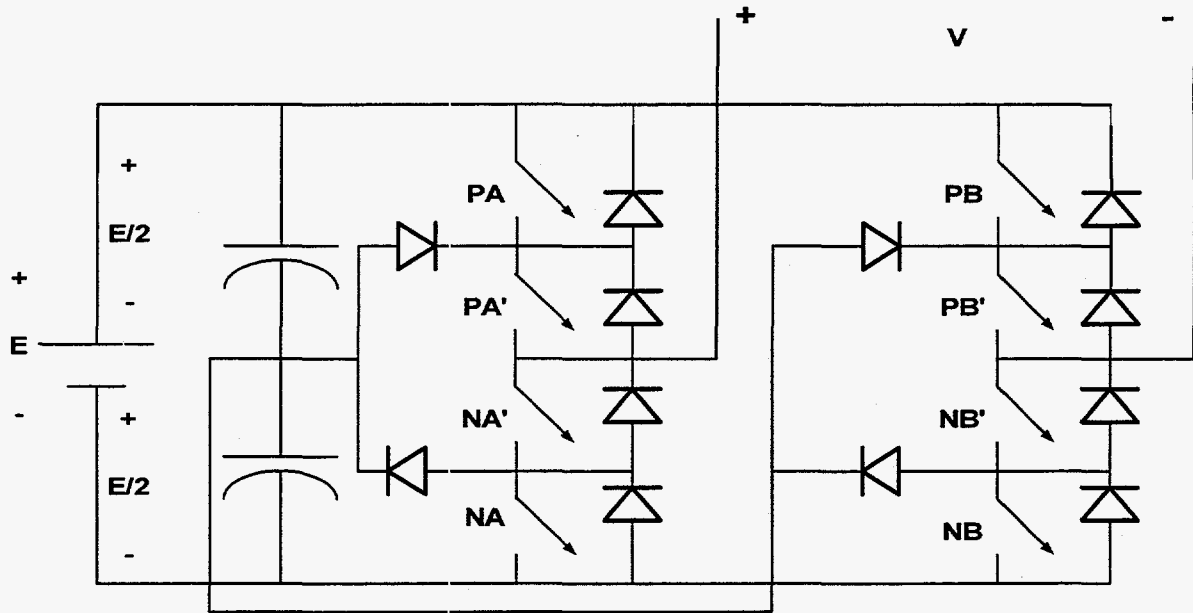

Figure B-24. Single-phase, three-level voltage-source inverter.

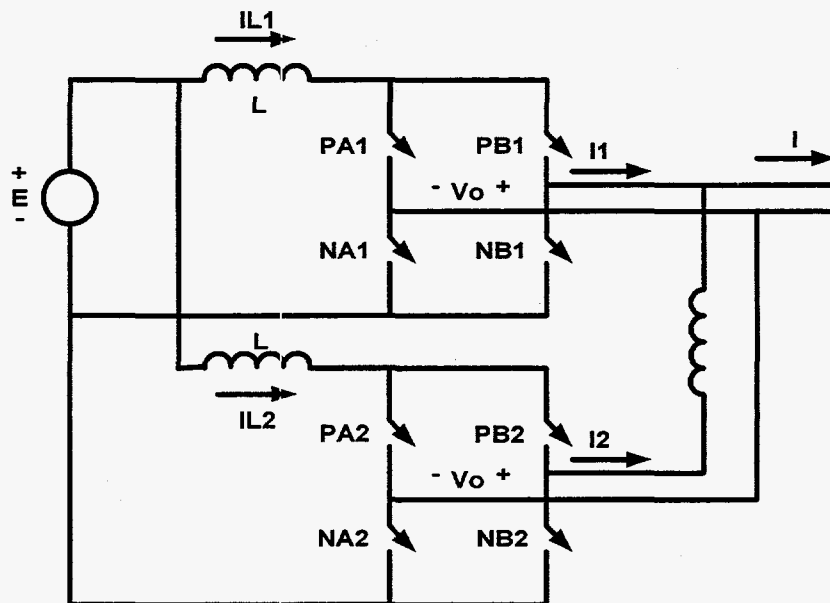

Figure B-25. Single-phase, three-level current-source inverter.

Considering the voltage-source inverter of Figure B-24, the output voltage V can take the values 0 , $E/2$, E , $-E/2$, or $-E$ depending on which switches are closed. For example, closing switches PA , PA' , NB , and NB' produce a voltage $V=E$ with current being supplied by or to both the source (E) and the capacitors. Closing PA' , NB , and NB' creates a voltage $V=E/2$ with current being supplied by or to the lower capacitor. In the simplest case, then, the switches can be controlled to create a stepped square wave, or three-level type voltage shown in Figure B-26. Additional waveform control can be obtained by PWM.

Appendix B—Inverters

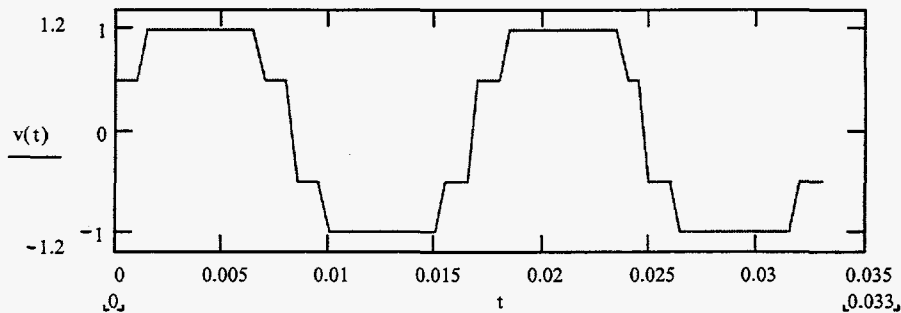

Figure B-26. Voltage (current) waveform for a three-level voltage-source (or current-source) inverter.

The multilevel current-source inverter of Figure B-25 operates in a similar manner. Each inverter can supply a current of either 0 or $IL1$ either from terminal a to b or in the reverse direction. Because the switches in each inverter can be controlled independently, the output current can be set to $2IL1$, $IL1$, 0, $-IL1$, or $-2IL1$. In the simplest case, the output AC current can be made to be the stepped square wave of Figure B-26. Recall that the line-commutated inverter also synthesizes such waveforms but does so by using specific input transformer connections. The multilevel converter eliminates the need for such transformers. As in the voltage-source inverter, PWM can also be used for waveform control.

A principle advantage of multilevel converters is that they can operate at higher voltage (or current) without physically connecting the devices in series or parallel arrangements. Additionally, waveform control is more easily obtained. One disadvantage may be that the control schemes are somewhat more complicated. For example, in the voltage-source inverter the charge/discharge conditions of the capacitor must be controlled so that their average voltages remain at $E/2$. Any imbalance in these voltages would cause deterioration in waveform quality.

Inverter Control

This section provides a discussion of generic controls associated with inverters, focussing again on ESS-type applications. As discussed in the main body of the report, target applications include the relatively slow area control/frequency regulation, voltage regulation, and emergency power supply applications as well as the faster power quality applications. Inverter controls generally involve the following three control loops:

- Outer control loop
- Inner control loop
- Functional control loop

A block diagram of the relationship between the inner and outer control loops is shown in Figure B-27. The functional control loop is not included because, as will be discussed in greater detail below, this loop can either be internal to the inverter or can comprise additional circuits external to the inverter.

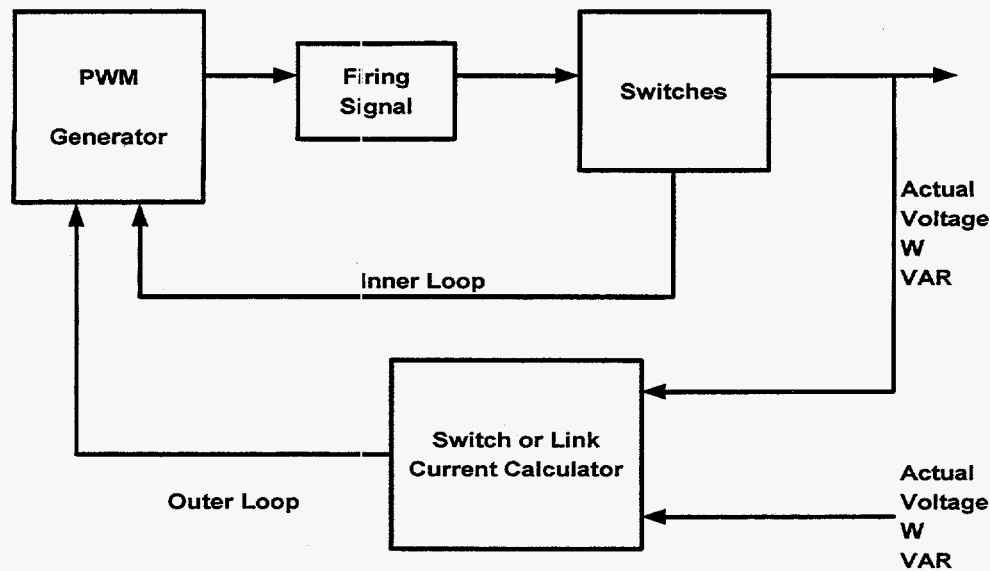

Figure B-27. Relationship between the inner and outer control loops.

Inner Control Loop

In general, the inner loop controls the current delivered to the utility and, in a bidirectional inverter, to the energy storage device. Very often the application control commands are translated in an inverter current command or reference set point. The inverter current is then controlled to match this reference. Control of inverter current provides an additional benefit of (slow) protection of semiconductor devices in the sense that current is limited to device rating. However, this control loop can be implemented as a voltage control as well.

The specific forms of the control depend on the inverter type. In a line-commutated inverter, for example, the inner loop determines the required firing angle usually through a proportional integral regulator that compares the desired DC current with the actual DC current. If the DC voltage is fixed, then only the firing angle can be controlled, and consequently only one variable (real or reactive power) can be controlled. If the DC voltage can be varied, then two quantities can be controlled. Note, however, that even in the latter case, the reactive power absorbed by the inverter is always positive. Force-commutated, low-frequency inverters have an essentially fixed switching pattern. Thus, only the relative phase of AC voltage (current) can be adjusted when the DC voltage or current is fixed. Consequently, the inner control loop is similar to that of a line-commutated inverter. High-frequency inverters use PWM techniques that permit the adjustment of both magnitude and phase (frequency). A large number of PWM techniques exist, and the principle ones are summarized below.

Sinusoidal PWM (SPWM)

Figure B-28 illustrates the SPWM method. The reference sine wave $m(t)$ is the desired current or voltage to be synthesized. This sine wave is compared with a synchronized triangle wave $tri(t)$ whose frequency is an odd multiple of the frequency of the reference wave.

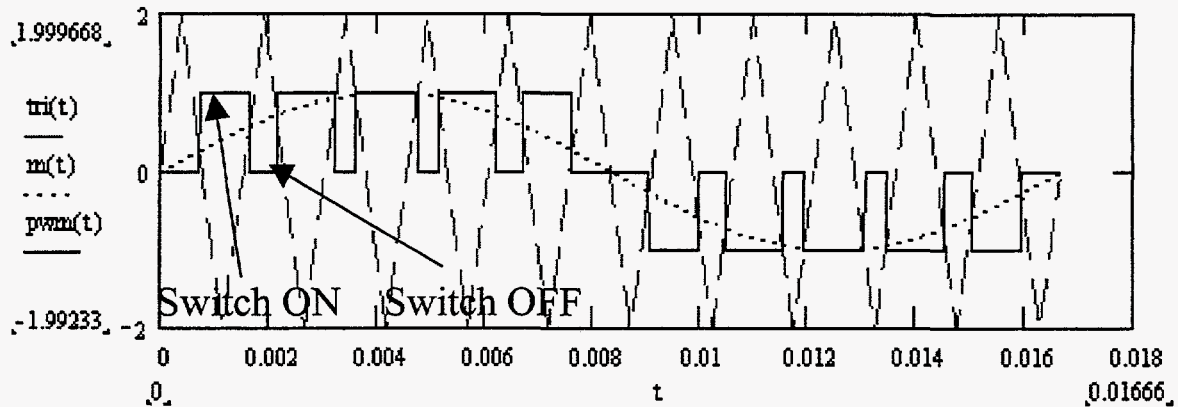

Figure B-28. Sinusoidal PWM.

The intersections determine the switching instants of the devices as annotated on the waveform, $pwm(t)$, in Figure B-28. In each switching interval, the duty ratio, D , is defined as the ON time of the switch divided by the switching period. It is seen in Figure B-28 that D varies over the reference wave cycle in a sinusoidal manner. Recall that for the basic inverter in Figure B-1, the P devices are switched to generate the positive half cycle, while the N devices are switched to generate the negative half cycle.

In SPWM the resulting waveform contains the desired fundamental component and harmonic frequencies centered around multiples of triangle-wave frequency. The harmonic frequencies are relatively easily filtered. The amplitude of the fundamental component increases with the modulation ratio, which is the ratio of the amplitude of the sine wave to that of the triangle wave. Thus, the output waveform amplitude and phase is controlled directly by the reference sine wave. The reference wave can, of course, be any desired waveform provided that the switching (triangle wave) frequency is much higher than the highest frequency in the reference wave.

Hysteresis-based PWM

This method is illustrated in Figure B-29. The sine wave, s_m , is the reference current desired and the jagged waveform, c_m , is the actual current. If the actual current is below reference, an appropriate switch is turned ON to cause the current to increase. If the actual current is higher, switches are turned ON or OFF to decrease the current. The corresponding voltage is shown as v_m . The actual current thus tracks the reference current within a “hysteresis band.” This approach has better tracking and control properties than other PWM methods.

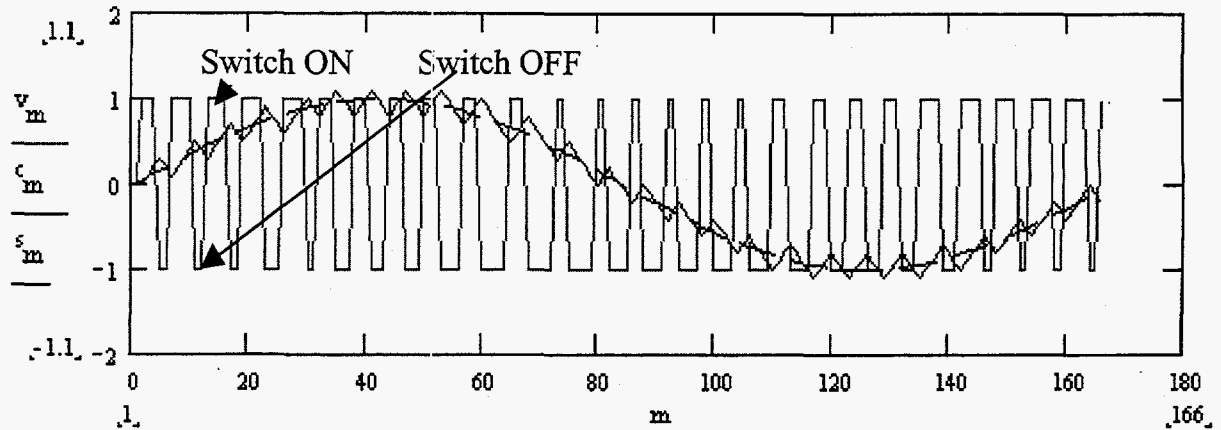

Figure B-29. Hysteresis-based PWM.

Space-vector PWM

Consider the multilevel single-phase converter in Figure B-24 that was previously discussed. This converter can generate voltage levels of $-E, -E/2, 0, E/2,$ and E (E is the DC voltage). In its simplest form, the space-vector method attempts to track a reference waveform by switching between the nearest voltage levels available. For example, suppose one period of the sinusoidal reference waveform s_m is divided into M intervals, (i.e., the switching frequency is a multiple, M , of the desired frequency). In a specific interval suppose the reference voltage or desired value is $0.3E$. This value can be generated by closing switches that yield $E/2$ volts for $0.6T$ seconds and zero volts for $0.4T$ seconds, where T is the interval width. This corresponds to a local duty ratio, $D=0.6$. The local average voltage, then, is $0.3E$ over the interval. Figure B-30 illustrates the voltage v_m obtained from the space-vector approach.

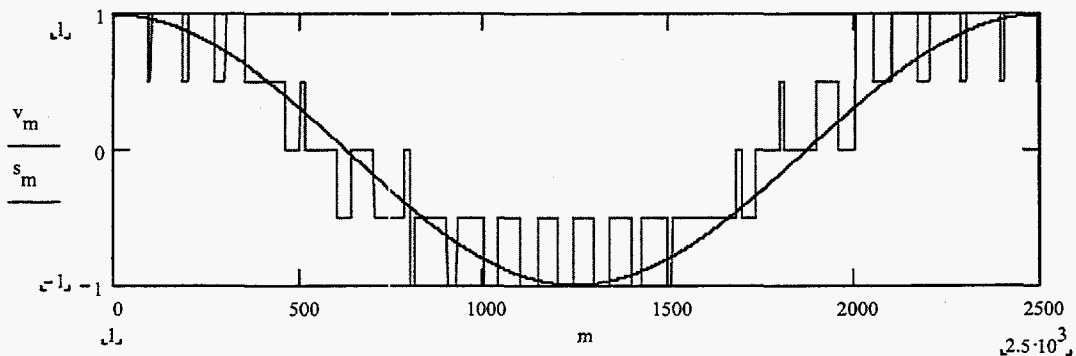

Figure B-30. Space-vector PWM.

Outer Control Loop

The outer control loop controls the output requirement at the load. This loop uses voltage, current, and power measurements from the inverter terminals to determine the voltage or current to be supplied by the inverter. In grid-independent applications the inverter must also regulate frequency.

Appendix B—Inverters

For example, consider a grid-connected application for voltage regulation. The inverter can be considered to be an ideal voltage ($V\angle\delta$) or current ($I\angle\theta$) source. The magnitude and phase of this AC source must be controlled in a way that will maintain constant voltage. Figure B-31 shows this voltage source tied to a power system. The power system generally appears as a source ($E\angle 0$) with inductive impedance (jX). For simplicity, resistance is ignored.

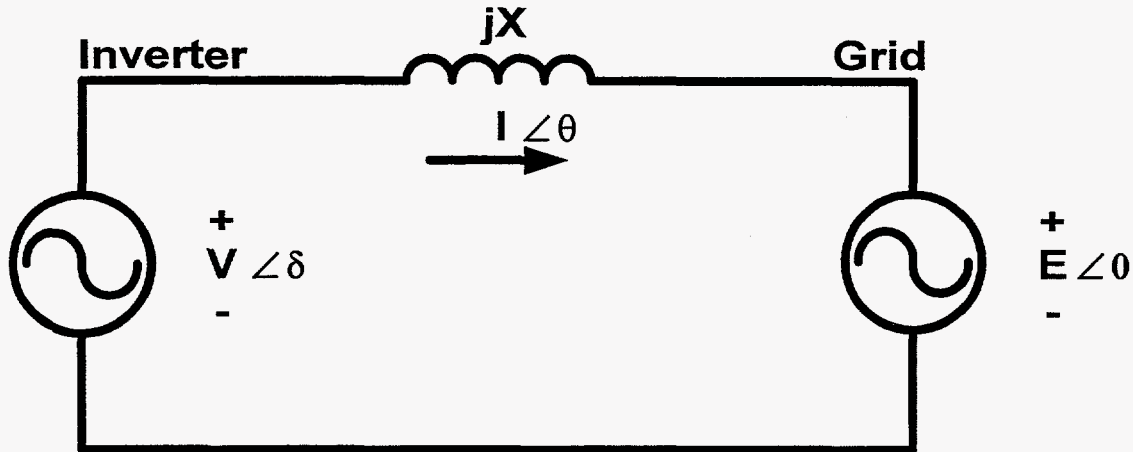

Figure B-31. Example circuit for a grid-connected ESS inverter.

The real power, P , and reactive power, Q , delivered by a voltage-source inverter to the grid are described by the following equations:

$$P(\text{Watts}) = VE \sin \delta / X \quad (\text{B-4})$$

$$Q(\text{VAR}) = (V^2 - VE \cos \delta) / X \quad (\text{B-5})$$

Equation B-4 indicates that real power is a function of AC voltage magnitudes, V and E , and the phase angle, δ , between voltages. Given that voltage magnitudes can only be allowed to vary within a rather narrow band (e.g., $\pm 5\%$), the real power is primarily a function of the phase angle. Conversely, the real power output of the inverter can be controlled by adjusting the phase angle of the inverter voltage with respect to the terminal voltage.

The phase angle between voltages is also tied to local frequency. For example, if the inverter frequency were increased, then the relative phase angle, δ , will begin to increase. Of course, steady-state operation requires that the two frequencies be equal. Thus, a temporary increase in inverter frequency advances the phase angle and increases output power. (This is also the mechanism by which the real output power of a rotating generator is increased. An increase in prime-mover power temporarily accelerates the machine, thereby increasing the phase angle and real output power. In stable systems, a new equilibrium is established.)

Equation B-5 shows that reactive power is strongly dependent on voltage magnitude, particularly for small values of phase angle, δ . Thus, ideally, increasing V causes the inverter to increase reactive power output. Conversely, in a power system with inductive series impedances, an increase in reactive power supply raises voltage magnitudes.

Alternatively, if the inverter is to be an ideal current-source inverter then the equations are as follows:

$$V / \delta = E - IX \sin \theta + jIX \cos \theta \quad (\text{B-6})$$

$$V \approx (E - IX \sin \theta) \text{ and } \delta = \tan^{-1}(IX \cos \theta / (E - IX \sin \theta)) \quad (\text{B-7) and (B-8)}$$

$$Q = VI \sin \theta \quad (\text{B-9})$$

$$P = VI \cos \theta \quad (\text{B-10})$$

Thus any pair of the quantities, voltage magnitude, real and reactive power can be controlled by controlling the magnitude and phase angle of the current.

Inverter control can then be organized in several ways. Some examples are as follows:

- Base on voltage regulation error to determine the reactive power requirement. Control voltage magnitude to yield desired reactive power.
- Base on voltage regulation error to determine the current magnitude and phase required. Control the current to drive the voltage regulation error to zero.
- Use voltage regulation error to directly control the magnitude and phase of the inverter voltage.

Specific advantages and disadvantages of each scheme depend on response requirements. Other applications, for example power quality, may require waveform control. In this case the inverter is controlled to generate a voltage and current based directly on a desired response. The discussion above applies to three-phase systems also. The problem can be transformed to stationary coordinates which provides better control.

Functional Control Loop

The functional control loop regulates the relationship between the PCS and the other system components. The functional control loop is conceptually the same as the supervisory control loop associated with hybrid systems. The supervisory control loop, however, is usually a slow loop that, for example, supervises the charging and discharging of the system's battery banks.

Functional, or supervisory, control may be internal or external to the inverter or some combination of the two. Currently, most of the logic that controls the relationship between the PCS and the other system components is application specific. In other words, the logic and the circuits are designed specifically for the application and power range in which the PCS is being used. Sometimes this logic is inside the inverter, and sometimes it is not. It is thought that some control functions that are currently built into the inverter could be taken out. Removing these control functions would reduce the complexity and the footprint of the inverter, which is considered desirable.

Conclusion

This appendix has provided a basic review of DC-to-AC conversion, or inversion, techniques and issues. It is important to note that the basic topologies have been presented in their

Appendix B—Inverters

simplest form. Research in academia and industry continues to produce new types of inverters that are either incremental modifications of existing topologies aimed at solving an application-specific problem, or fundamentally different approaches to the inversion process. This appendix largely covers all of the currently available concepts, but not the detailed circuits.

It is tempting to ask if a particular approach is optimal for energy storage systems in general. The limited number of ESS applications to date makes this question somewhat difficult to answer. For example, despite the advantages of soft-switching technologies, an ESS design might utilize a hard-switching approach simply because of the extensive experience and available hardware. Similarly, a low-frequency approach with expensive filtering may be more economical in some instances than the development of a higher frequency design. This section summarizes the basic concepts already discussed and provides some insight as to the suitability of the various approaches for ESS applications.

An ideal inverter, or more properly converter, in an ESS or any other application would have the following features:

- Bidirectionality
- Independent control of AC real and reactive power
- Sinusoidal voltage and current (more practically, low distortion and low EMI)
- Fast control (subcycle with respect to 60 Hz)
- Small footprint

In practice tradeoffs exist that determine the overall cost per kVA.

The basic inverter consists of a set of switches arranged in the form of a bridge topology. By turning switches ON and OFF in a specific sequence, DC voltage or current can be converted to AC (inversion) or AC voltage and current can be converted to DC (rectification). The magnitude and phase of AC voltage and current can be controlled to supply or absorb real and reactive power over a range dictated by the type of circuit and devices used.

The bridge topology can be voltage- or current-source. A SMES, for example, is naturally a current source, while a battery is a voltage source. However, with the appropriate filter circuit choice, a voltage source can be made to appear as a current source. For example, a battery can be connected to an inverter through a series inductor to create a current-source inverter. In this instance, the control of bidirectional power flow can become more complicated; charging the battery requires switching the battery polarity (additional hardware) or reversing the current (slow response). On the AC side, a current-source inverter usually requires a shunt-capacitive filter, while a voltage-source inverter is usually interfaced through a series inductor. A desired relationship between voltage and current can be maintained through feedback control in either inverter. The voltage-source inverter is often preferred in modern implementations, because it is somewhat easier to control, has very good bidirectional capability, and may have a lower device count than a current-source inverter.

The switches and switching pattern used in an inverter depends on the voltage and current rating desired. At very high power levels, the SCR is the only switch available and the line-commutated inverter becomes the topology of choice. Operation is controlled by varying the firing angle. Bidirectional flow of real power can be achieved, but the inverter always absorbs real power. Waveform control requires extensive use of passive harmonic filters. In

the 5- to 50-MW range, force-commutated (SCR-based) and self-commutated (GTO- and MCT-based) inverters are becoming prevalent in the areas of motor control and utility static VAR control. Motor controls tend to use current-source inverters while several utility applications use voltage-source inverters. These systems use low frequency (300-800 Hz) PWM to reduce filtering requirements. Note that in this high-MW range substantial voltage capability (tens to hundreds of kV) and current capability (several kA) are required. In the 500-kVA range, IGBT-based voltage-source inverters using PWM switching at several kHz have been used in ESSs, motor-drives, and UPSs. Even at this higher switching frequency, the need for passive filters remains significant. These systems involve voltages and current below 1000 V and 1000 A.

The push for higher PWM switching frequency derives from a desire to reduce the bulky passive filters required to attenuate low frequency harmonics. Additionally, the filtering of EMI and elimination of audible noise is possible. It should be noted that switching frequencies of 20 kHz and higher are used in small (several hundred VA) power supplies and UPSs and 5-kVA inverters switching at this frequency have been used in the PV area. The principle barrier to higher PWM switching frequency at the medium power levels has been device switching speed and increased switching losses. This has led to the development of resonant soft-switched approaches. The resonant DC link is a viable concept but may be limited to a few hundred kVA. However, it may be possible to achieve switching frequencies greater than 20 kHz. Initially, these circuits suffered from a major disadvantage—switching devices had to be rated at substantially higher voltage and current than the actual system voltage and current. This problem has been effectively solved by recent research. Generally, the control of switching patterns in these inverters is much more complex. Advanced PWM methods, such as space-vector modulation, are actively being researched. Current research indicates that these approaches are certainly viable and advantageous in the 200- to 500-kVA range. As devices advance it may be possible to extend these approaches to the multimewatt range.

Multilevel converters represent yet another way to achieve good waveform control at higher power levels when slower devices must be used. In utility-type applications they have the benefit of reducing filtering and interface requirements. Both voltage- and current-source inverters can be used in multilevel converters. Finally, there are topologies such as the matrix converter that may provide advantages but have not advanced to a level that permits adequate evaluation for ESS applications.

Figure B-32 and Figure B-33 summarize these observations. Figure B-32 displays different types of device/topology combinations in the space of kVA rating and switching frequency. Figure B-33 shows a rough taxonomy of inverter types. At this time, anticipated ESS applications target the 5-kW to 1-MW range and the 1- to 10-MW range. In the lower range, and in particular in systems involving several hundred volts and amperes, the entire family of inverter technology is available for ESS applications. Applications fielded in this area exclusively use hard-switched PWM inverters. Soft-switched inverters may offer significant advantages in terms of system compatibility (filtering), efficiency, and footprint. In the multimewatt range, system voltages and currents may be in the order of kV and kA. There have been few applications fielded in this range, although several utility power quality applications can integrate an ESS device. The hard-switched technology with series/parallel connections and appropriate transformers is viable in this range. The technology could be

Appendix B—Inverters

simplified if higher-rated devices were available. The multilevel converters are viable in this range and indeed have been used in utility static VAR systems. At this time it is difficult to extrapolate the availability of soft-switching topologies in this range in the near term. Finally, in the very high power range, which is not a direct target for ESS, technology is still limited to the line-commutated converter and the GTO-based, low-frequency PWM voltage-source inverter.

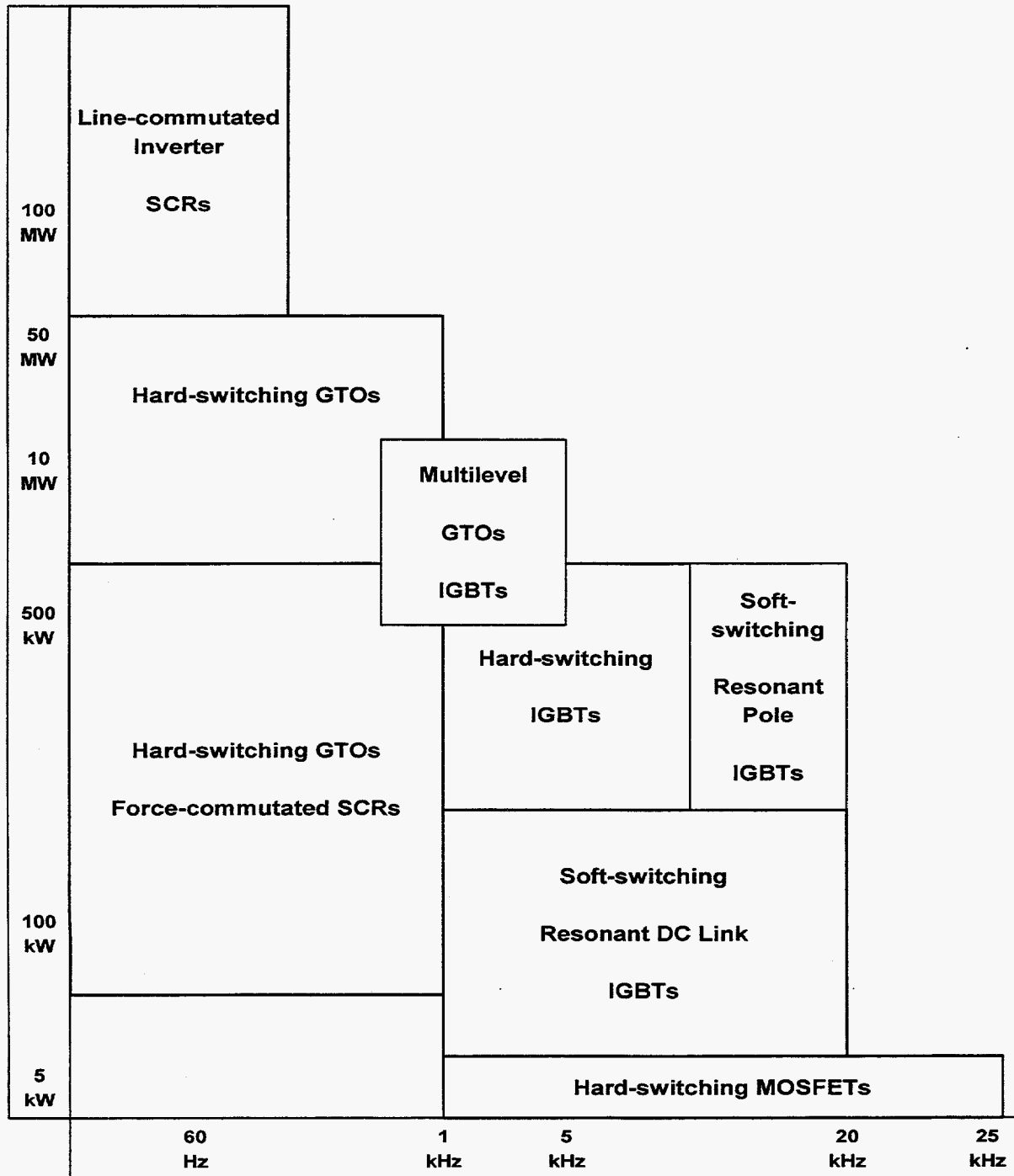

Figure B-32. Inverter technology by rating and switching frequency.

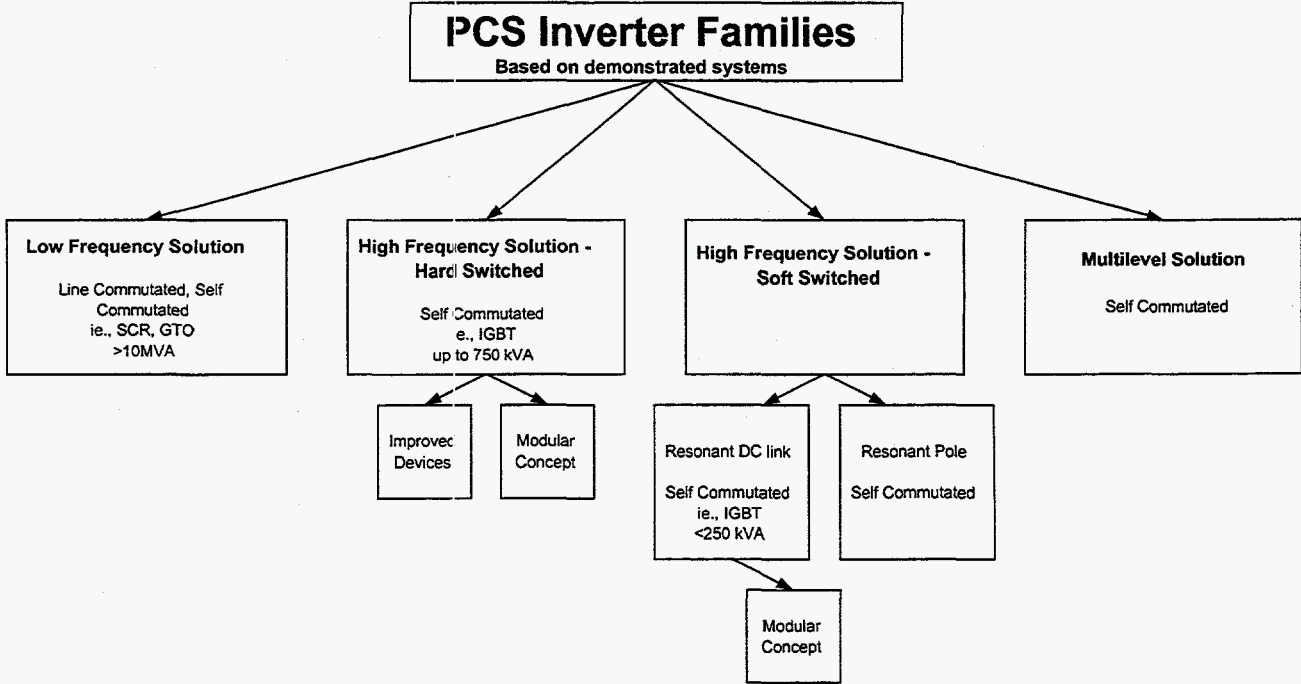

Figure B-33. Inverter taxonomy.

Appendix C—Semiconductor Switches

Overview

As discussed in the main report and in Appendix B, control of ESSs and inverters is accomplished by configuring different types of switches to achieve a desired result. This appendix focuses on controllable switches. Controllable switches can be classified into two “families”—the transistor family and the thyristor family. Specific switch types and the characteristics common to the two families are shown in Table C-1.

Table C-1. Controllable Switches

Transistor Family	Thyristor Family
IGBT, MOSFET, BJT	GTO, MTO, IGCT, SCR, MCT
Lower power	High power
Faster turn-off and turn-on	Slower turn-off, moderate turn-on
More control flexibility	Less control flexibility

The choice of which switch to use depends on the application and on designer preference. When selecting a switch for use in an application, the voltage and current ratings and the switching frequency must all be considered. The switching losses that occur during high-frequency operation must also be considered. For a more thorough discussion of diodes, controlled-rectifiers, and semiconductors see “Introduction to Power Electronics” (Bose).

Controllable Switches

Controllable switches need to be able to block large forward and reverse voltages with no current flow when OFF (in other words, stay OFF) and conduct arbitrarily large currents with zero voltage drop when ON (in other words, stay ON). They also should be able to switch ON and OFF instantaneously and with little power dissipation. Power loss in a semiconductor switch varies linearly with the switching frequency and switching times. “An ideal power semiconductor switch has zero conduction drop, zero leakage current at OFF condition, and turns on and off instantaneously.” (Bose)

State-of-the-art in these switches is advancing rapidly and new types of controllable switches are always being developed. The means by which the switches are turned ON and OFF is one of the main distinguishing features of the different types of switches. Generally semiconductor switches can be divided into the transistor family and the thyristor family. Switches in these families each have advantages and disadvantages for particular applications. The switch families and the most common types of switches are discussed in greater detail below.

Transistor Family

In general, semiconductor switches in the transistor family are lower power, have a faster turn-on and turn-off, and have more control flexibility when compared to semiconductors in the thyristor family.

Appendix C—Semiconductor Switches

Bipolar Junction Transistor (BJT)

BJTs are current-controlled and a base current must be continuously supplied to keep the device on.

Metal-oxide-semiconductor Field Effect Transistor (MOSFET)

MOSFETs are voltage-controlled and require a continuous gate-source voltage to be ON. MOSFET switching times are very short.

Insulated-gate Bipolar Transistor (IGBT)

“An IGBT is basically a hybrid MOS-gated turn on/off bipolar transistor that combines the attributes of MOSFET, BJT, and thyristor.” (Bose)

Thyristor Family

Silicon-controlled Rectifier (SCR)

SCRs are turned on by a pulse of current applied to a gate terminal. Once turned ON, they are latched in the ON position until sufficient current is removed by an external circuit. The three major types of SCRs are phase-controlled, inverter-grade, and light-activated. In an SCR, the recovery time (the time it takes for the current to reach zero from the negative) is less important than the turn-off time interval. This interval (sometimes called the circuit-commutated recovery time) is the time it takes for both the current and the voltage to reach zero (a crossover point). During this time a reverse voltage must be maintained because a forward voltage will turn the switch on prematurely. If the switch is turned on prematurely, the switch and/or the circuit could be damaged.

Gate-turn-off Thyristor (GTO)

GTOs are turned ON with current and turned OFF with large negative current. They do not require constant current across the switch, but do require a “very large magnitude” gate current to successfully turn off (Mohan, et al.). Present day GTOs require a snubber circuit to turn off. Snubbers are there to reduce dv/dt at turn-off. The ON-state voltage is higher than that of SCRs.

MOS-turn-off Thyristor (MTO)

An MTO is turned ON with current and turned OFF with voltage, which eliminates the need for a large negative current to turn OFF (as is required by the GTO). The voltage must be continuous to keep the switch in the OFF state. According to Silicon Power Corporation representatives, “The MTO thyristor will replace the GTO and promises to meet the need for simplified gate control at all the power levels now served by the GTO.”

Integrated Gate-commutated Thyristor (IGCT)

IGCTs are similar to GTOs. The main benefits of IGCTs are high-current and low ON-state voltage, which eliminates the need for snubbers (which must be used with GTOs).

MOS-controlled Thyristor (MCT)

MCTs can be turned ON and OFF by small pulses on the MOS gate. It is similar to a GTO, “except the turn-off current gain is very high.” (Bose) Its switching speed is comparable to that of an IGBT, but it has a lower conduction drop. MCTs are also capable of operating at high temperature ranges—they are rated at 150°C and can probably operate successfully at higher temperatures. MCTs can be connected in series/parallel arrangements to accommodate higher-power applications. “In next-generation power electronics, MCTs are expected to offer a serious challenge to other high-power devices.” (Bose)

Summary

Semiconductor technology is advancing rapidly. It is thought that continued improvement in semiconductor switches will increase their ratings and reduce their cost. Better ratings and lower cost should in turn improve the efficiency and cost of inverters as a whole.

Table C-2 shows a summary of some of the more widely used semiconductors. The IGBT is used as a baseline. Additionally, Figure C-1 and Figure C-2 show the voltage and current ratings for the most commonly used semiconductors. **Note:** The maximum voltage and current are generally not available simultaneously.

Table C-2. Semiconductor Comparison (normalized)

	IGBT	GTO	IGCT
Max Current/Voltage Rating	1	9	4
Control Capability	1	1/4	1/2
Max Operating Frequency	1	1/20	1/2
Device Protection	1	1/4	1/2
Cost	1	1/4	3/4

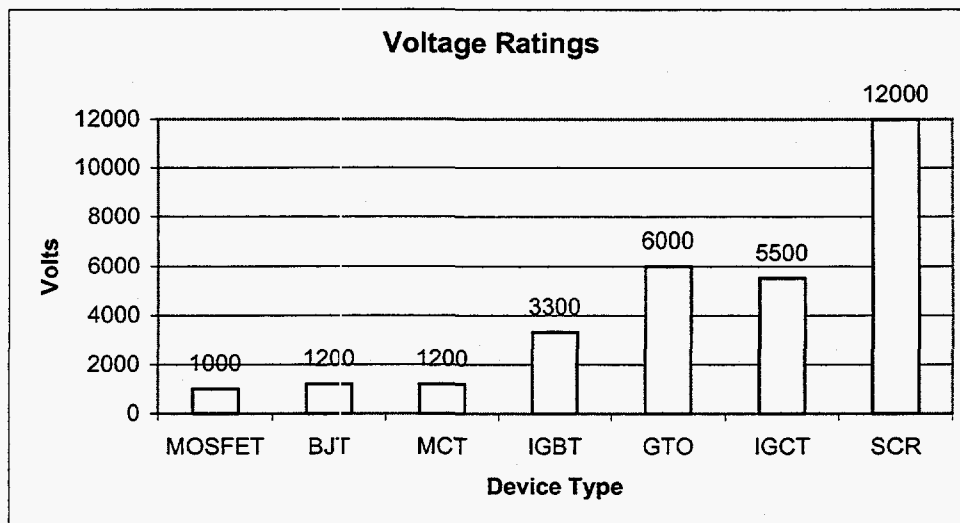

Figure C-1. Voltage ratings for commonly used semiconductors.

Appendix C—Semiconductor Switches

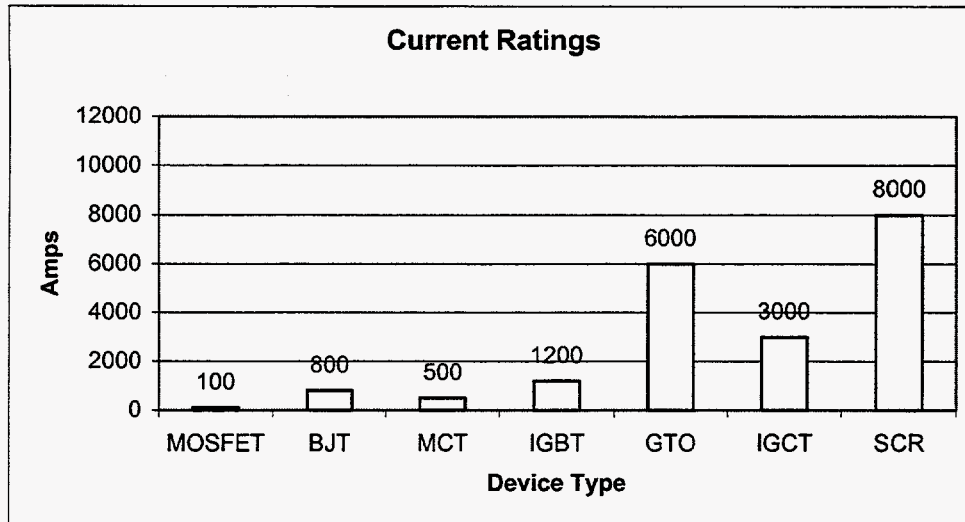

Figure C-2. Current ratings for commonly used semiconductors.

In addition to advances in device structure, the development of new materials will also lead to improved switches. Materials such as silicon carbide (SiC), gallium nitride (GaN), aluminum nitride (AlN), and diamond all have a wider band gap than the silicon that is presently used in semiconductor switches. This wider band gap should allow the switches to carry more power, to be less sensitive to heat and electromagnetic radiation, and to be more stable than silicon-based switches. PCSs based on these new switches should be faster, more efficient, and more robust than existing PCSs. Of the new materials, SiC is the closest to commercialization.

Appendix D—Advanced Energy Storage Electrical Interface

This section describes some specific SMES and flywheel energy storage systems currently being used for utility applications. These systems are examples of how a PCS can be used with non-battery technologies. This section is not intended to discuss all of the possible SMES and flywheel interfaces to the PCS.

American Superconductor Concept

American Superconductor (formerly Superconductivity, Inc.) specializes in the sale of commercial products and the research and development of superconducting magnetic energy storage (SMES) technology. Their other core capabilities include power electronics and system analysis. SMES is a type of storage device that stores energy in superconducting magnetic fields. One of American Superconductor's current developments is a system known as a PQ VR™ system. The PQ VR™ system is a superconducting storage device that is designed to compensate for voltage sags by adding the power needed to compensate for the reduced voltage. This system inserts the appropriate voltage vector via three single-phase injection transformers in series with the utility power and the protected load. The transformer ratio can be designed such that the system can be rated for 50% or 75% of the maximum voltage boost.

The first PQ VR™ was commissioned in April of 1997. This system was connected to a paper mill in South Africa to provide for dip protection of 75% (75% voltage boost). The one-line diagram that illustrates how the system is connected to the paper mill is shown in Figure D-1.

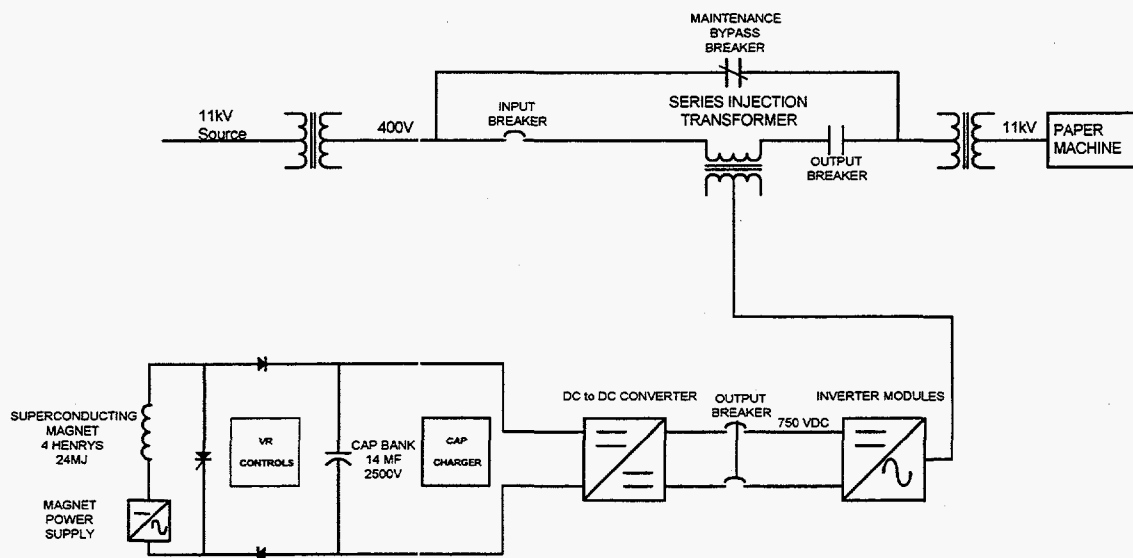

Figure D-1. One-line diagram for the PQ VR™ system at the SAAPI Stanger Mill.

Figure D-1 shows the superconducting magnet connected to a voltage regulator, a DC-to-DC converter, and a commercially available inverter that is directly tied to a series-injection transformer and then to the load. The voltage regulator contains a GTO switch and control instrumentation that provides constant power input into the DC-to-DC converter by

Appendix D—Advanced Energy Storage Electrical Interface

regulating the length of the pulse train from the magnet. To increase the utilization of the magnetic device, a DC-to-DC converter is placed between the voltage regulator and the DC link of the inverter. The DC-to-DC converter places a 2500 VDC discharge voltage across the magnet but allows the output voltage to be regulated anywhere within a window of 500 to 950 VDC. The inverter is an IGBT-based module that provides the required AC power at the injection side of the single-phase series transformers. Each inverter module is rated to 1.3 MVA total output. Based on the sag protection chosen, the load size (protected) is 1.3 MVA/sag%. For example, a 480-VAC, 75% system would serve a 1.7-MVA load at approximately 2000 A per phase.

The normal path for power flow is from the inverter through the series injection transformer to the paper machine. In the event of a disturbance, the magnetic storage supplies the power needed to compensate for the reduced voltage. The restored voltage level maintains the proper voltage and current levels at the load. The bypass switch and I/O breakers are used to allow for disconnection of the PQ VR™ system. The use of step-up and step-down transformers was necessary at the SAPPI Stanger Mill because the voltage rating for the first PQ VR™ is 400 V. The next PQ VR™ system, which is expected to operate at the 4160-V level, is currently being designed (Knudtson; Gravely).

Active Power Concept

Active Power, Inc. specializes in flywheel energy storage systems. Flywheels are energy storage devices that store energy as a rotating mass. Active Power designs, manufactures, and markets the CleanSource™ family of flywheel energy storage systems. Some of Active Power's targeted applications for CleanSource™ systems include continuous power, power quality improvement, and battery isolation and redundancy. The power quality application is presented below because it is one of the seven target applications described in the main report.

The CleanSource™ concept is to provide a source of power that protects sensitive equipment from power outages, voltage sags, and brownouts. The CleanSource™ system is configured as a two-terminal DC power storage system, similar to a chemical battery bank. As with a chemical battery, the CleanSource™ device receives recharge and float power from the two-terminal UPS DC bus and returns power to the same DC bus whenever the bus voltage drops below a programmed threshold level. For a power quality application, the CleanSource™ system can be configured in a UPS double-conversion topology as shown in Figure D-2.

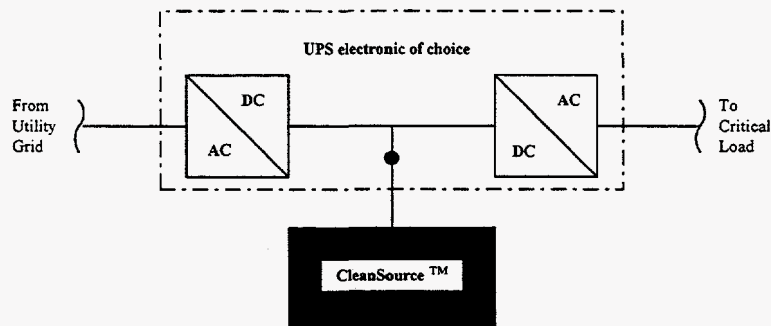

Figure D-2. Power quality glitch protection configuration.

Appendix D—Advanced Energy Storage Electrical Interface

The heart of the CleanSource™ device is an integrated motor/generator/flywheel system that is capable of storing and delivering up to 400 kW of DC power to the DC bus of the UPS. The motor, generator, and storage functions are all performed by the same stator and rotor structure. These systems can be paralleled (like batteries) for higher-power requirements. The CleanSource™ device can be represented by the diagram shown in Figure D-3.

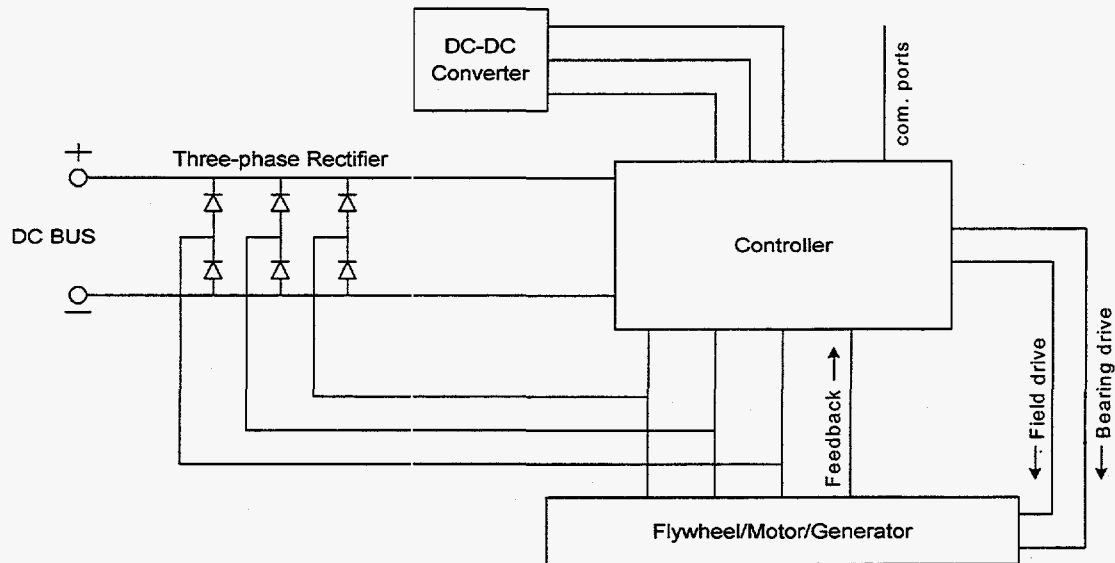

Figure D-3. CleanSource™ device.

The DC-to-DC converter is used to supply DC power from the DC bus to the controller. In the charge state the controller allows power to be drawn from the UPS DC bus to the flywheel motor to accelerate the rotor. When the flywheel reaches its fully charged speed, it enters a mode comparable to a chemical battery's "float state," in which small amount of power is drawn from the UPS's DC bus. During discharge, the controller senses when the DC bus voltage falls below a preset minimum, the motor function is disabled, and the controller allows the generator output voltage to increase. Once the generator voltage increases above a threshold level, the rectifier turns ON and the DC bus is held at a constant voltage that is independent of the rotor speed. When the power at the utility is restored, the UPS rectifier brings the DC bus voltage back to its normal value and the flywheel resumes charging (CleanSource™ Technical Overview; Active Power web page).

International Computer Power Concept

International Computer Power designs and manufactures the Dynamic Energy Storage System (DESS). The DESS is a kinetic storage system that uses a flywheel-coupled motor generator topology. Figure D-4 shows a simplified block diagram of a DESS. DESSs are available from 5 kW to 1 MW as single modules, but may be paralleled for system redundancy or for multimewatt capacities. Primary applications of the DESS include UPS battery operation and battery backup systems. The UPS battery concept is discussed in further detail below.

Appendix D—Advanced Energy Storage Electrical Interface

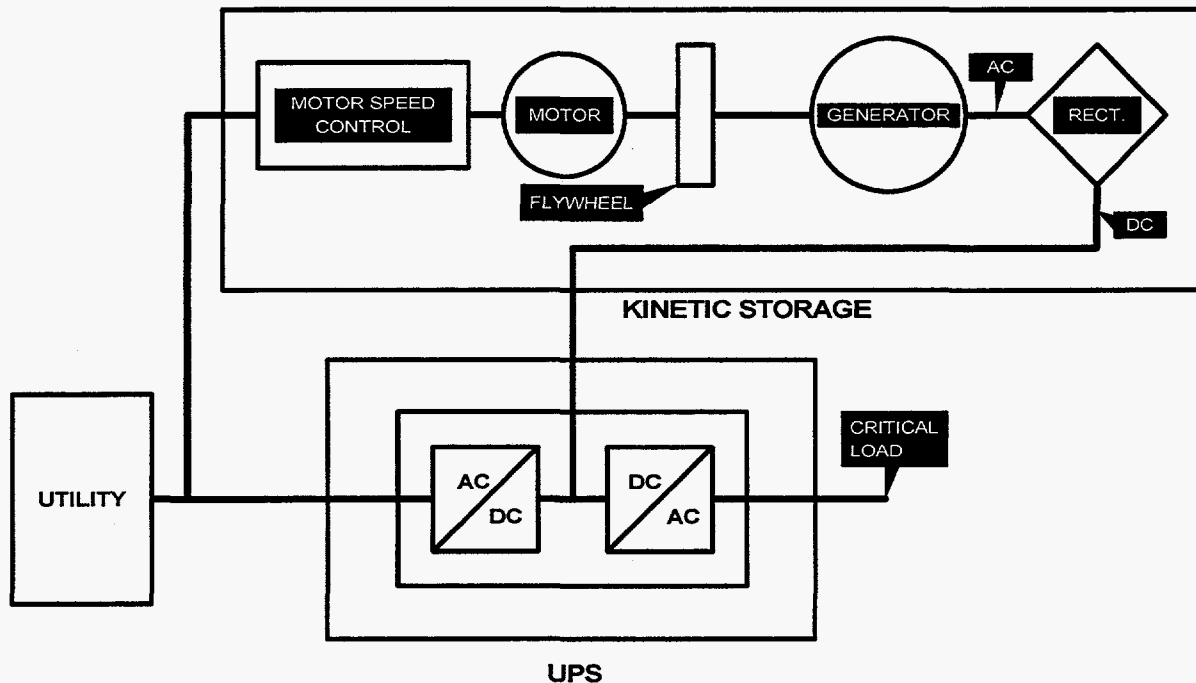

Figure D-4. DESS used for UPS applications.

The DESS approach consists of a flywheel-coupled motor generator system that provides a rectified DC output from the flywheel's kinetic energy. The five major system components in the DESS include a motor-speed controller or variable speed drive (VSD), a small induction motor, a flywheel, a brushless synchronous generator, and a diode bridge rectifier. The VSD is used to slowly ramp the flywheel up to speed and maintain the desired rpm. The small induction motor (usually sized at 15-20% of the rated system output) is used to start the flywheel and to maintain its normal operational speed. The synchronous generator is used to convert the kinetic energy stored in the flywheel into electrical energy or AC power. The diode bridge rectifier is used to convert the AC generator output to DC for use by the UPS DC bus, which continues to draw usable energy independent of the flywheel's rpm. The rectifier allows the DC voltage output to be maintained over a greater range of the flywheel's rpm envelope.

The standard DESS is directly connected to the UPS DC bus, but it may be configured for parallel operation with an existing storage battery array, or used with an inverter in a series configuration for standby operation. In the series configuration, the DESS and a dedicated inverter remain off-line to provide power instantly when the utility fails.

Appendix E—R&D Needs: Industry Responses

ABB Industrial Systems, Inc.

Tor-Eivind Moen, Product Manager, Power Electronics Systems

- More research is needed for emerging storage technologies, such as SMES, to reduce cost and increase longevity, reliability, and availability. Emerging storage technologies still appear to be very expensive, and therefore, less attractive right now.
- The market for power quality applications in the 1- to 10-MW range, voltage regulation in the 1-MVAR range, customer demand peak reduction in the 1-MW range, and area control/frequency regulation in the 10-MW range has been very slow. Several companies are waiting for the market to take off in these areas. Once the market, application, and product needs become clear, and with significant high-volume production, then most certainly the cost of PCSs will come down.
- Research in the power electronics could be made, but will have less impact on the overall balance of plant.
- Footprint varies with the type of application. Continuously rated transformers are usually larger than discontinuously rated units (i.e., power quality applications). Switchgears usually increase in size for higher voltage ratings (i.e., a 600-V switchgear is smaller in footprint than 4.16-kV rated switchgear).

Abacus Controls, Inc.

George O'Sullivan, President

- The greatest potential reduction in cost is in economy of scale, that is the amortization of the engineering costs over a large number of units produced. For example, a car company producing a million cars per year amortizes the engineering cost over the million units, thus the engineering cost becomes a small portion of the overall cost of the car.

Exide Electronics

John Breckenridge, Director of North American Service Operations

- Focus on standardization of power electronics for various applications such as voltage regulation, customer demand peak reduction, and area control/frequency regulation. Standardization reduces engineering design time, thus reducing overall cost. Once standardized, companies can get into mass production to further reduce cost. Need to get into production mode with market availability. Government, with the help of customers and industry, should help to standardize PCS integration.
- Exide doesn't see major cost reductions in energy storage technologies, but in power electronics.

Appendix E—R&D Needs: Industry Responses

John Messer, Director of Design & Development Engineering

- There is a need to reduce cost, volume, weight, and noise in high-frequency magnetics used in filters. There has been no significant progress made in this area.
- There has been a fair amount of progress in AC capacitors, such as harmonic filters, but less in DC capacitors for the DC link. Commonly used capacitors for the DC link is electrolytic-type capacitors. There is a potential for reducing both the cost and volume for DC link capacitors.
- There is a need for R&D in semiconductor devices. Heat transfer for large systems is usually a problem. Large-kVA-rated PCSs use a lot of fans for thermal management. Fans are high-failure-rate items. Few manufacturers use liquid-cooled system for thermal management because they have a high potential for leaks and are unreliable. Semiconductors are limited in voltage and current ratings. Current practice is to use paralleled devices to meet higher rating requirements. Exide uses two paralleled blocks for use in their 750-kVA rated systems. Paralleling devices is only useful to a limited extent because equal current sharing in devices becomes hard to achieve if more than two devices are paralleled.
- Exide doesn't see a lot of market potential in power quality in the 1- to 10-MVA range. To achieve 1- to 10-MVA rated requirements, the current practice is to parallel modules. Extra units (n+1) are also required for redundancy.
- DC and AC switchgears are high-cost and high-footprint items. There might be a potential for reduction here.

Liebert Corporation

Richard Walden, Manager of Integrated Power Systems

- Increased efficiency and reduced cost are the most important elements at the higher-power ranges (i.e., 1- to 10-MVA power quality applications). Higher power ranges would most like to see lower switching frequencies. At high power ratings, faster switching frequencies decrease efficiency due to increased switching losses. Higher-power rated applications usually have lower cost when compared with lower-power rated equipment (a 4-MVA module usually costs less [in \$/kVA] than a 1-MVA module). This is due to fixed costs between both ratings. As an example, the design of the controller in the 4-MVA and 1-MVA modules would be the same or have a fixed cost, consequently decreasing the overall cost of the module at higher ratings.
- Power electronics ratings are usually device limited. Current practice is to use paralleled devices to meet the higher-power requirements. It would be preferable to have a single higher-rated device rather than having multiple devices in parallel. UPS manufacturers usually go with best and most immediate solutions for their systems—that is, they use the SCR technology available today at lower frequencies for high power rated installation. Components used in UPS applications are usually available today and reliable.
- The cost of transformers and switchgears has become high at higher power levels. The cost jumps significantly between low-voltage rated equipment and medium-voltage rated equipment. Liebert usually operates at low voltage ratings to reduce switchgear and equipment costs. Low-voltage operation is achieved by a step-down

transformer that reduces the medium-level voltage to a lower voltage level (12.47 kV to 480 V).

- Liebert sees flywheel technology as near to commercialization. Certain applications that require short-term outages/reclosure events and high cycling might be promising for flywheels. SMES and supercapacitors are too costly at this time.

Orion Energy Corporation

Doug Danley, President

- R&D funding should be spent on the system interfaces between power electronics and the rest of power systems such as diesel generators, PV, and batteries. Concentrate on system integration that would change the cost structure. Time should not be spent on incremental changes to current technologies, for example, better IGBTs to reduce cost, but rather concentrate on system-level changes.
- Adapt hardware and software better.
- Focus on radical changes with high-risk and high-payoff projects, for example, design a flywheel, fuel cell, PV hybrid system. This would open the market for other storage technologies. Concentrate on advanced system controllers to integrate power electronics and multiple storage technologies.
- Approach R&D from the system perspective. Determine the capabilities of storage and renewable devices now and in the future. Determine what the customer wants. Once the system-level capabilities and needs are specified, then determine what the power electronics can do for the specifications. This will identify gaps and determine directions for DOE funding. Many times, companies look at R&D from the other side of the coin. They would determine power electronics capabilities first and then determine how they could integrate the energy storage technologies. Companies are already doing this. Why should DOE follow the same path? Funding should be concentrated towards system-level changes. Start from a clean slate and go from there.
- Three major cost structures can be associated with the cost estimate for a device. They are as follows:
 1. Cost of components
 2. Integration and assembly cost
 3. Cost associated with the value of the device to customer.

Item 1 has some cost reduction potential, but not much compared to the overall system. In other words, IGBT costs are decreasing but would not have a significant impact on overall cost of the system. Item 2 provides the greatest cost reduction potential. If you better integrate your system and have enhanced manufacturing techniques and mass production the price tends to go down. Enhancements in manufacturing techniques reduce manufacturing cost. This provides consistency of production thus increasing the quality of the device. Integration of the system, such as replacing analog discrete functions with microprocessor-based chips that perform the same functions, yields better quality devices. Item 3 depends on the capability of the device. Price could fluctuate depending on the manufacturer. If a device has better features the price tends to go up.

Appendix E—R&D Needs: Industry Responses

Trace Technologies Corporation

Mike Behnke, Vice President

- Need cheaper, lighter, and smaller magnetics for filter inductors. There is currently no research being done in this area.
- Need a higher level of integration (reduction in components) in control systems. About half of Trace's control board consists of analog circuitry. A smaller package could be achieved by replacing analog circuits with digital circuits.
- Need R&D in semiconductor development (i.e., higher voltage- and current-rated IGBTs). The increased voltage and current ratings in IGBTs could open up markets in the medium-level conversions, such as 4.16 kV, and could potentially eliminate the need for snubbers and DC-to-DC subconversions before the DC link. There is a tradeoff though—if the energy source is directly connected to the DC link of the inverter, this will require higher-rated DC switches (above 600 V, for instance) which usually increases cost. The elimination of some subcircuits will reduce cost, but higher-rated components such as switches could bring the cost back up.
- R&D needed in converter control software development. Software needs to be more user-friendly to allow systems integrators to add more value, and to allow end users the flexibility to modify the operation of the control system as future needs dictate.

Westinghouse Electric Corporation

Neil Woodley, Marketing Manager, Custom Power Products

- Need improved cost performance—bigger devices, better cooling, and higher efficiency. Utility equipment is tough and can withstand extreme anomalies, such as high current surges. Power electronics, on the other hand, cannot tolerate extreme anomalies. A more robust system is needed.
- Device cooling is an issue. A dual-sided cooling system would be preferred over single-sided cooling. Westinghouse currently uses forced air to cool their devices. Liquid cooling systems could be used but reliability and market acceptance is a problem.
- Efficiency is an issue. Reduction in switching loss and thermal management are desirable.

Appendix F—Acronyms and Abbreviations

AC: alternating current

AC/FR: area control/frequency regulation

ANSI: American National Standards Institute

ART: auxiliary resonant tank

BJT: bipolar junction transistor

CDPR: customer demand peak reduction

BOS: balance of system

DC: direct current

DESS: Dynamic Energy Storage System

DOE: United States Department of Energy

DSTATCOM: dynamic static compensator

DVR: dynamic voltage restorer

EMI: electromagnetic interference

EPRI: Electric Power Research Institute

ESS: energy storage system

ESSP: Energy Storage Systems Program

FACTS: flexible AC transmission system

FCC: Federal Communications Commission

GTO: gate turn-off thyristor

HVAC: heating, ventilation, and air conditioning

HVDC: high-voltage direct current

IEC: International Electrotechnical Commission

IEEE: Institute of Electrical and Electronics Engineers

IGBT: insulated-gate bipolar transistor

IGCT: integrated gate-commutated thyristor

LC: inductive-capacitive

LV: large village

Appendix F—Acronyms and Abbreviations

MCT: MOS-controlled thyristor

MOSFET: metal-oxide-semiconductor field effect transistor

MOV: metal-oxide varistor

MTO: MOS turn-off thyristor

NEC: National Electrical Code

NEMA: National Electrical Manufacturers Association

NESC: National Electric Safety Code

NFPA: National Fire Protection Association

ORNL: Oak Ridge National Laboratories

PCS: power conversion system

PDM: pulse density modulation

PEBB: Power Electronics Building Blocks

PIC: power integrated circuit

PMAG: permanent magnet axial gap

PQ: power quality

PV: photovoltaic(s)

PWM: pulse-width modulation

R&D: research and development

RDCL: resonant DC link

RLC: resistive-inductive-capacitive

RMS: root-mean-square

ROI: rate of inflation

RSI: resonant snubber inverter

SCR: silicon-controlled rectifier

SMES: superconducting magnetic energy storage

SNL: Sandia National Laboratories

SV: small village

THD: total harmonic distortion

UBF: unbalance factor

Appendix F—Acronyms and Abbreviations

UL: Underwriters Laboratory

UPS: uninterruptible power supply

VR: voltage regulation

VSD: variable speed drive

ZVS/ZCS: zero-voltage switching/zero-current switching

Appendix G—Bibliography and References

Active Power, Inc. CleanSource™ Technical Overview. 1997.

Active Power web page. <http://www.activepower.com>.

Akhil, A.A.; Swaminathan, S.; Sen, R.K. "Cost Analysis of Energy Storage Systems for Electric Utility Applications." SAND97-0443. Sandia National Laboratories, February 1997.

Bose, B.K. "Introduction to Power Electronics." from *Modern Power Electronics: Evolution, Technology, and Applications*, B.K. Bose, editor. IEEE Press: New York; 1992.

Bower, W. "Merging Photovoltaic Hardware Development with Hybrid Applications in the U.S.A." SAND93-2145C. Sandia National Laboratories, December 1993.

Butler, P.C. "Battery Energy Storage for Utility Applications—Phase I: Opportunities Analysis." SAND94-2605 (VC-212). Sandia National Laboratories, November 1995.

Divan, D.M. "The Resonant DC Link Converter—A New Concept in Static Power Conversion." IEEE Transactions on Industry Applications. March 1989, 25(2).

Energetics, Inc. Workshop Report, "Power Processing Systems: Perspectives on Requirements for Renewable Generation and Energy Storage Systems." Workshop Sponsored by DOE and SNL: Columbia; March 1994.

FCC Rules and Regulations. Part 15, Subpart J. FCC.

Gravely, M. American Superconductor (formerly Superconductivity, Inc.): Executive Vice President, interview, 1997.

Guygi, L. "A Unified Power Flow Control Concept for Flexible AC Transmission Systems." IEEE Proceedings –C. July 1992, 139(4).

Hamilton, D.B. United States Office of Transportation Technologies, interview, May 1997.

Horn, D.T. *Basic Electronics Theory*. TAB Books: Blue Ridge Summit; Second Edition, 1985.

Kassakian, J.G.; Schlecht, M.F.; Verghese, J.G. *Principles of Power Electronics*. Addison-Wesley: New York; 1991.

Knudtson, G. "Power Quality Solutions Using Micro-SMES Technology." Presented at CSUS PQ97, 1997.

Krein, P.T. *Elements of Power Electronics*. Oxford University Press: New York; 1998.

Lai, J.S.; Peng, F.Z. "Multilevel Converters—A New Breed of Power Converters." IEEE Transactions on Industry Applications. May/June 1996, 32(3).

Lee, F.C.; Chen, D.Y. "Power Devices and Their Applications." VPEC Publications Series. Volume III, 1990.

Appendix G—Bibliography and References

Malesani, L.; Tenti, P.; Tomasin, P.; Toigo, V. "High-efficiency Quasi-resonant DC Link Three-phase Power Inverter for Full Range PWM." IEEE Transactions on Industry Applications. January/February 1995, 31(1).

Mohan, N.; Undeland, T.M.; Robbins, W.P. *Power Electronics: Converters, Applications, and Design*. Prentice Hall: New York; Second Edition, 1997.

Nabae, A., Takahashi, I., Akagi, H., "A New Neutral Point Clamped PWM Inverter." IEEE Transactions on Industry Applications. September/October 1989, IA-17(5).

National Electrical Code. Articles 70 and 690. National Fire Protection Association, 1996.

National Electric Safety Code. Section 9, "Grounding Methods for Electric Supply and Communication Facilities;" Section 12, "Installation and Maintenance;" and Section 14, "Storage Batteries."

Nilsson, S.L. Silicon Power Corporation: Executive Vice President, interview, 1997.

PEBB web page. <http://www.pebb.onr.navy.mil>.

Peng, F.; Lai, J.; McKeever, J.; VanCovering, J. "A Multilevel Voltage-Source Inverter with Separate DC sources for Static Var Generation." IEEE Transactions on Industry Applications. March 1996, 32(5).

"Photovoltaic Power Conditioning: Status and Needs." EPRI GS-2230. Project 1996-2000 Final Report. Prepared by Stity & Associates for SNL and EPRI; June 1991.

UL1741, "Standard for Inverters, Charge Controllers, and AC Modules for Use in Residential Photovoltaic Systems." Underwriters Laboratory.

Venkatraman, G.; Divan, D. M. "Pulse Width Modulation with Resonant DC Link Converters." IEEE Transactions on Industry Applications. March 1993, 29(1).

Vithayathil, J. *Power Electronics*. McGraw Hill: New York; 1996.

Walden, R. Liebert Corporation: Manager of Integrated Power Systems, interview, 1997.

Walker, L.H. "Battery Storage Plants." *Encyclopedia of Electrical and Electronic Engineering*. Wiley and Sons: New York; 1997.

Woodley, N.H.; Sarkozi, M.; Sundarm, A.; Taylor, G.A. "Custom Power: The Utility Solution." Presented at 13th International Conference on Electricity Distribution (CIRED). Brussels, Belgium. May 1995.

Bob Weaver
777 Wildwood Lane
Palo Alto, CA 94303

Amber Gray-Fenner
7204 Marigot Rd. NW
Albuquerque, NM 87120

Per Danfors
ABB Power T&D Co., Inc.
16250 West Glendale Drive
New Berlin, WI 53151

Hans Weinerich
ABB Pwr. T&D Co., Inc.
1460 Livingston Ave.
P.O. Box 6005
North Brunswick, NJ 08902-6005

Robert Wills
Advanced Energy Systems
Riverview Mill
P.O. Box 262
Wilton, NH 03086

P. Crump
Alaska State Div. of Energy
333 West Fourth Ave.
Suite 220
Anchorage, AK 99501-2341

Percy Frisbey
Alaska State Div. of Energy
333 West Fourth Ave.
Suite 220
Anchorage, AK 99501-2341

B. Tiedeman
Alaska State Div. of Energy
333 West Fourth Ave.
Suite 220
Anchorage, AK 99501-2341

C. Shih
American Elec. Pwr. Serv. Corp.
1 Riverside Plaza
Columbus, OH 43215

S. Amanda Chiu
American Superconductor Corp.
Two Technology Drive
Westborough, MA 01581

Meera Kohler
Anchorage Municipal Light & Pwr
1200 East 1st Avenue
Anchorage, AK 99501

Tim Ball
Applied Power Corporation
Solar Engineering
1210 Homann Drive SE
Lacey, WA 98503

Gary Henriksen
Argonne National Laboratories
9700 South Cass Avenue
CTD, Bldg. 205
Argonne, IL 60439

Bill DeLuca
Argonne National Laboratories
9700 South Cass Avenue
CTD, Bldg. 205
Argonne, IL 60439

Ray Hobbs
Arizona Public Service
400 North Fifth Street
P.O. Box 5399, MS8931
Phoenix, AZ 85072-3999

Herb Hayden
Arizona Public Service
400 North Fifth Street
P.O. Box 5399, MS8931
Phoenix, AZ 85072-3999

Edward Kern
Ascension Technology
P.O. Box 6314
Lincoln Center, MA 01773

Gary Markle
AVO International
510 Township Line Rd.
Blue Bell, PA 19422

Glenn Campbell
Babcock & Wilcox
P.O. Box 785
Lynchburg, VA 24505

Walt Stolte
Bechtel Corporation
P.O. Box 193965
San Francisco, CA 94119-3965

Klaus Kramer
Berliner Kraft und Licht (BEWAG)
Stauffenbergstrasse 26
1000 Berlin 30
GERMANY

Salim Jabbour
Business Management Consulting
24704 Voorhees Drive
Los Altos Hills, CA 94022

Dr. Sudhan S. Misra
C&D Charter Pwr. Systems, Inc.
Washington & Cherry Sts.
Conshohocken, PA 19428

Jon Edwards
California Energy Commission
1516 Ninth Street, MS-46
Sacramento, CA 95814

Rod Boucher
Calpine Corporation
50 W. San Fernando
Suite 550
San Jose, CA 95113

Tom Lovas
Chugach Elec. Association, Inc.
P.O. Box 196300
Anchorage, AK 99519-6300

N. Tai
Consolidated Edison
4 Irving Place
New York, NY 10003

R. B. Sloan
Crescent EMC
P.O. Box 1831
Statesville, NC 28687

J. Michael Hinga
Delphi Energy & Engine
Management Systems
P.O. Box 502650
Indianapolis, IN 46250

Joseph J. Iannucci
Distributed Utility Associates
1062 Concannon Blvd.
Livermore, CA 94550

Samuel B. Wright
Boeing
Inform., Space & Defense Sys.
P.O. Box 3999 MS 82-97
Seattle, WA 98124-2499

Dr. Les Holden
C&D Charter Pwr. Systems, Inc.
Washington & Cherry Sts.
Conshohocken, PA 19428

Larry S. Meisner
C&D Powercom
1400 Union Meeting Road
P.O. Box 3053
Blue Bell, PA 19422-0858

J. Holmes
California State Air Resc. Board
Research Division
P.O. Box 2815
Sacramento, CA 95812

John Cooley
Chugach Elec. Association, Inc.
P.O. Box 196300
Anchorage, AK 99519-6300

M. Lebow
Consolidated Edison
4 Irving Place
New York, NY 10003

R. Stack
Corn Belt Electric Cooperative
P.O. Box 816
Bloomington, IL 61702

Bob Galyen
Delphi Energy. & Engine
Management Systems
P.O. Box 502650
Indianapolis, IN 46250

Bob Rider
Delphi Energy & Engine
Management Systems
P.O. Box 502650
Indianapolis, IN 46250

John N. Baker
EA Technology, Ltd.
Chester CH1 6ES
Capenhurst, England
UNITED KINGDOM

Jim DeGruson
Eagle-Picher Industries, Inc.
C & Porter Street
Joplin, MO 64802

Daniel R. Bruck
ECG Consulting Group, Inc.
55-6 Woodlake Road
Albany, NY 12203

Steve Eckroad
Elec. Pwr. Research Institute
P.O. Box 10412
Palo Alto, CA 94303-0813

Dave Feder
Electrochemical Energy
Storage Systems, Inc.
35 Ridgedale Avenue
Madison, NJ 07940

Michael Dodge
Electrosource
P.O. Box 7115
Loveland, CO 80537

Phil DiPietro
Energetics
501 School Street SW
Suite 500
Washington, DC 20024

Howard Lowitt
Energetics
7164 Gateway Drive
Columbia, MD 21046

Jennifer Schilling
Energetics
501 School Street SW
Suite 500
Washington, DC 20024

Laura Johnson
Energetics, Inc.
7164 Gateway Drive
Columbia, MD 21046

Al Pivec
Energy Systems Consulting
41 Springbrook Road
Livingston, NJ 07039

M. Stanton
East Penn Manufact. Co., Inc.
Deka Road
Lyon Station, PA 19536

Steve Chapel
Elec. Pwr. Research Institute
P.O. Box 10412
Palo Alto, CA 94303-0813

Robert Schainker
Elec. Pwr. Research Institute
P.O. Box 10412
Palo Alto, CA 94303-0813

Phillip C. Symons
Electrochemical Engineering
Consultants, Inc.
1295 Kelly Park Circle
Morgan Hill, CA 95037

Eric Rudd
Eltech Research Corporation
625 East Street
Fairport Harbor, OH 44077

Mindi J. Farber DeAnza
Energetics
501 School Street SW
Suite 500
Washington, DC 20024

Rich Scheer
Energetics
501 School Street SW
Suite 500
Washington, DC 20024

Paula A. Taylor
Energetics
7164 Gateway Drive
Columbia, MD 21046

Greg J. Ball
Energy & Env. Economics, Inc.
353 Sacramento Street
Suite 1540
San Francisco, CA 94111

Dale Butler
EnerTec Pty. Ltd.
349 Coronation Drive
PO Box 1139, Milton BC Old 4044
AUCHENFLOWER, QUEENSLAND 4066
AUSTRALIA

Robert Duval
EnerVision
P.O. Box 450789
Atlanta, GA 31145-0789

John Breckenridge
Exide Electronics
8609 Six Forks Road
Raleigh, NC 27615

J. Mills
Firing Circuits, Inc.
P.O. Box 2007
Norwalk, CT 06852-2007

Dave Coleman
Frost & Sullivan
2525 Charleston Road
Mountain View, CA 94043

Steven Kraft
Frost & Sullivan
2525 Charleston Road
Mountain View, CA 94043

Bob Zrebiec
GE Industrial & Pwr. Services
640 Freedom Business Center
King of Prussia, PA 19046

Declan Daly
General Electric Drive Systems
1501 Roanoke Blvd.
Salem, VA 24153

Nick Miller
General Electric Company
1 River Road
Building 2, Room 605
Schenectady, NY 12345

A. LaConti
Giner, Inc.
14 Spring Street
Waltham, MA 02254-9147

J. Boehm
GNB Tech. Ind. Battery Co.
Woodlake Corporate Park
829 Parkview Blvd.
Lombard, IL 60148-3249

Sanjay Deshpande'
GNB Technologies
World Headquarters
375 Northridge Road
Atlanta, GA 30350

George Hunt
GNB Tech. Ind. Battery Co.
Woodlake Corporate Park
829 Parkview Blvd.
Lombard, IL 60148-3249

Bob Maresca
GNB Tech. Ind. Battery Co.
Woodlake Corporate Park
829 Parkview Blvd.
Lombard, IL 60148-3249

Joe Szymborski
GNB Tech. Ind. Battery Co.
Woodlake Corporate Park
829 Parkview Blvd.
Lombard, IL 60148-3249

Steven Haagensen
Golden Valley Elec. Assoc., Inc.
758 Illinois Street
P.O. Box 71249
Fairbanks, AK 99701

Ben Norris
Gridwise Engineering Company
121 Starlight Place
Danville, CA 94526

Clyde Nagata
Hawaii Electric Light Co.
P.O. Box 1027
Hilo, HI 96720

George H. Nolin
HL&P Energy Services
P.O. Box 4300
Houston, TX 77210-4300

Carl Parker
ILZRO
2525 Meridian Parkway
P.O. Box 12036
Research Triangle Park, NC 27709

Jerome F. Cole
ILZRO
2525 Meridian Parkway
PO Box 12036
Research Triangle Park, NC 27709

Patrick Moseley
ILZRO
2525 Meridian Parkway
P.O. Box 12036
Research Triangle Park, NC 27709

Ken Belfer
Innovative Power Sources
1419 Via Jon Jose Road
Alamo, CA 94507

John Neal
International Business & Tech.
Services, Inc.
9220 Tayloes Neck Road
Nanjemoy, MD 20662

Frank McLarnon
Lawrence Berkeley Nat'l Lab
University of California
One Cyclotron Road
Berkeley, CA 94720

Susan Schoenung
Longitude 122 West
1241 Hobart Street
Menlo Park, CA 94025

Joseph Morabito
Lucent Technologies, Inc.
600 Mountain View Ave.
P.O. Box 636
Murray Hill, NJ 07974-0636

D. Nowack
Micron Corporation
158 Orchard Lane
Winchester, TN 37398

Larry Flowers
Nat'l Renewable Energy Lab
1617 Cole Boulevard
Golden, CO 80401-3393

Susan Hock
Nat'l Renewable Energy Lab
1617 Cole Boulevard
Golden, CO 80401-3393

Holly Thomas
Nat'l Renewable Energy Lab
1617 Cole Boulevard
Golden, CO 80401-3393

R. Myers
Imperial Oil Resources, Ltd.
3535 Research Rd. NW
Calgary, Alberta, T2L 2K8
CANADA

David Warar (2)
Intercon Limited
6865 Lincoln Avenue
Lincolnwood, IL 60646

Elton Cairns
Lawrence Berkeley Nat'l Lab
University of California
One Cyclotron Road
Berkeley, CA 94720

Kim Kinoshita
Lawrence Berkeley Nat'l Lab
University of California
One Cyclotron Road
Berkeley, CA 94720

Cecilia Y. Mak
Lucent Technologies
300 Skyline Drive
Room 855
Mesquite, TX 75149-1802

Dutch Achenbach
Metlakatla Power & Light
P.O. Box 359
Metlakatla, AK 99926

Richard DeBlasio
Nat'l Renewable Energy Lab
1617 Cole Boulevard
Golden, CO 80401-3393

Jim Green
Nat'l Renewable Energy Lab
1617 Cole Boulevard
Golden, CO 80401-3393

Byron Stafford
Nat'l Renewable Energy Lab
1617 Cole Boulevard
Golden, CO 80401-3393

Bill Brooks
NC Solar Center
Corner of Gorman & Western
Box 7401 NCSU
Raleigh, NC 27695-740

Andrew L. Rosenthal
New Mexico State University
Southwest Tech. Dev. Institute
Box 30001/Dept. 3SOL
Las Cruces, NM 88003-8001

Gary G. Karn
Northern States Power Co.
1518 Chestnut Avenue North
Minneapolis, MN 55403

Jack Brown
NPA Technology
Two University Place
Suite 700
Durham, NC 27707

Brendan Kirby
Oak Ridge National Laboratory
P.O. Box 2008
Bldg. 3147, MS-6070
Oak Ridge, TN 37831-6070

James VanCoevinger
Oak Ridge National Laboratory
P.O. Box 2008
Bldg. 3147, MS-6070
Oak Ridge, TN 37831-6070

Doug Danley
Orion Energy Corporation
10087 Tyler Place #5
Ijamsville, MD 21754

John DeStreese
Pacific Northwest Nat'l Lab
Battelle Blvd.
P.O. Box 999, K5-02
Richland, WA 99352

Stan Sostrom
POWER Engineers, Inc.
P.O. Box 777
3870 US Hwy 16
Newcastle, WY 82701

Henry W. Zaininger
Power Technologies, Inc.
775 Sunrise Avenue
Suite 210
Roseville, CA 95661

Rick Winter
Powercell Corporation
101 Main Street
Suite 9
Cambridge, MA 02142-1519

Bart Chezar
New York Power Authority
1633 Broadway
New York, NY 10019

Denise Zurn
Northern States Power Co.
414 Nicollet Mall
Minneapolis, MN 55401

Robert Hawsey
Oak Ridge National Laboratory
P.O. Box 2008
Bldg. 3025, MS-6040
Oak Ridge, TN 37831-6040

John Stoval
Oak Ridge National Laboratory
P.O. Box 2008
Bldg. 3147, MS-6070
Oak Ridge, TN 37831-6070

Hans Meyer
Omniion Pwr. Engineering Corp.
2010 Energy Drive
P.O. Box 879
East Troy, WI 53120

Dale Brown
Pacific Northwest Nat'l Lab
Battelle Blvd.
P.O. Box 999
Richland, WA 99352

Brad Johnson
PEPCO
1900 Pennsylvania NW
Washington, DC 20068

P. Prabhakara
Power Technologies, Inc.
1482 Erie Blvd.
P.O. Box 1058
Schenectady, NY 12301

Reznor I. Orr
Powercell Corporation
101 Main Street
Suite 9
Cambridge, MA 02142-1519

Roger Flynn
Public Service Co. of New Mexico
Alvarado Square MS-2838
Albuquerque, NM 87158

Jerry Neal
Public Service Co. of New Mexico
Alvarado Square MS-BA52
Albuquerque, NM 87158

Norman Lindsay
Queensland Department of
Mines and Energy
G.P.O. Box 194
Brisbane, 4001
QLD. AUSTRALIA

Al Randall
Raytheon Eng. & Constructors
700 South Ash Street
P.O. Box 5888
Denver, CO 80217

Ole Vigerstol
SAFT America, Inc.
711 Industrial Blvd.
Valdosta, GA 13601

Mike Saft
SAFT Research & Dev. Ctr.
107 Beaver Court
Cockeysville, MD 21030

G. E. "Ernie" Palomino
Salt River Project
P.O. Box 52025
MS PAB 357
Phoenix, AZ 85072-2025

Kurt Klunder
Sentech, Inc.
4733 Bethesda Avenue
Suite 608
Bethesda, MD 20814

Rajat K. Sen
Sentech, Inc.
4733 Bethesda Avenue
Suite 608
Bethesda, MD 20814

Clay Aldrich
Siemens Solar
4650 Adohn Lane
P.O. Box 6032
Camarillo, CA 93011

Jim Trotter
Solar Electric Specialists Co.
232-Anacapa Street
Santa Barbara, CA 93101

Wenceslao Torres
Puerto Rico Elec. Pwr. Authority
G.P.O. Box 4267
San Juan, PR 00936-426

J. Thompson
R&D Associates
2100 Washington Blvd.
Arlington, VA 22204-5706

K. Ferris
RMS Company
87 Martling Avenue
Pleasantville, NY 10570

Guy Chagnon
SAFT Research & Dev. Ctr.
107 Beaver Court
Cockeysville, MD 21030

H. Lundstrom
Salt River Project
P.O. Box 52025
MS PAB 357
Phoenix, AZ 85072-2025

Dr. Charles Feinstein
Santa Clara University
Dept. of Dec. & Info. Sciences
Leavey School of Bus. & Admin.
Santa Clara, CA 95053

Robert Reeves
Sentech, Inc.
9 Eaton Road
Troy, NY 12180

Nicole Miller
Sentech, Inc.
4733 Bethesda Avenue
Suite 608
Bethesda, MD 20814

Deepak Divan
Soft Switching Technologies
2224 Evergreen Road
Suite 6
Middleton, WI 53562

Scott Sklar
Solar Energy Ind. Assoc. (SEIA)
122 C Street NW
4th Floor
Washington, DC 20001-2104

Gerald W. Braun
Solarex
630 Solarex Court
Frederick, MD 21701

Naum Pinsky
Southern California Edison
2244 Walnut Grove Ave.
P.O. Box 800, Room 418
Rosemead, CA 91770

K. Vakhshoorzadeh
Southern Company Services, Inc.
600 North 18th Street
P.O. Box 2625
Birmingham, AL 35202-2625

Bob Bish
Stored Energy Engineering
7601 E. 88th Place
Indianapolis, IN 46256

Jennifer Billman
Superconductivity, Inc.
P.O. Box 56074
Madison, WI 53705-4374

Jon Hurwitch
Switch Technologies
4733 Bethesda Avenue
Suite 608
Bethesda, MD 20814

Thomas J. Jenkin
The Brattle Group
44 Brattle Street
Cambridge, MA 02138-3736

Tom Anyos
The Technology Group, Inc.
63 Linden Avenue
Atherton, CA 94027-2161

Michael Behnke
Trace Technologies
6952 Preston Ave.
Livermore, CA 94550

Donald J. Bender
Trinity Flywheel Power
6724D Preston Avenue
Livermore, CA 94550

Bruce R. Rauhe, Jr.
Southern Company Services, Inc.
600 North 18th Street
P.O. Box 2625
Birmingham, AL 35202-2625

Richard N. Schweinberg
Southern California Edison
6070 N. Irwindale Avenue
Suite I
Irwindale, CA 91702

C. Seitz
SRI International
333 Ravenswood Avenue
Menlo Park, CA 94025

George Zink
Stored Energy Engineering
7601 E. 88th Place
Indianapolis, IN 46256

Michael Gravely
Superconductivity, Inc.
P.O. Box 56074
Madison, WI 53705-4374

Terri Hensley
Tampa Electric Company
P.O. Box 111
Tampa, FL 33601-0111

Michael Orians
The Solar Connection
P.O. Box 1138
Morro Bay, CA 93443

Bill Roppenecker
TRACE Engineering Division
5916 195th Northeast
Arlington, WA 98223

Bill Erdman
Trace Technologies
6952 Preston Avenue
Livermore, CA 94550

Jim Drizos
Trojan Battery Company
12380-Clark Street
Santa Fe Springs, CA 90670

James Fangué
TU Electric
R&D Programs
P.O. Box 970
Fort Worth, TX 76101

Dr. Gerald P. Ceasar
U.S. Department of Commerce
NIST/ATP
Bldg 101, Room 623
Gaithersburg, MD 20899

Bob Brewer
U.S. Department of Energy
1000 Independence Ave. SW
EE-10 FORSTL
Washington, DC 20585

R. Eynon
U.S. Department of Energy
1000 Independence Ave. SW
EI-821 FORSTL
Washington, DC 20585

Pandit G. Patil
U.S. Department of Energy
1000 Independence Ave. SW
EE-32 FORSTL
Washington, DC 20585

Alex G. Crawley
U.S. Department of Energy
1000 Independence Ave. SW
EE-90 FORSTL
Washington, DC 20585

Allan Jelacic
U.S. Department of Energy
1000 Independence Ave. SW
EE-12 FORSTL
Washington, DC 20585

Dr. Christine E. Platt
U.S. Department of Energy
1000 Independence Ave.
EE-12 FORSTL
Washington, DC 20585

Jack Cadogan
U.S. Department of Energy
1000 Independence Ave. SW
EE-11 FORSTL
Washington, DC 20585

Jim Daley
U.S. Department of Energy
1000 Independence Ave. SW
EE-12 FORSTL
Washington, DC 20585

Paul Maupin
U.S. Department of Energy
ER-14 E-422
G-343/GTN
Germantown, MD 20874-1290

J. P. Archibald
U.S. Department of Energy
1000 Independence Ave. SW
EE-90 FORSTL
Washington, DC 20585

Tien Q. Duong
U.S. Department of Energy
1000 Independence Ave. SW
EE-32 FORSTL
Washington, DC 20585

Mark B. Ginsberg
U.S. Department of Energy
1000 Independence Ave. SW
EE-90 FORSTL 5E-052
Washington, DC 20585

Neal Rossmeissl
U.S. Department of Energy
1000 Independence Ave. SW
EE-13 FORSTL
Washington, DC 20585

Allan Hoffman
U.S. Department of Energy
1000 Independence Ave. SW
EE-10 FORSTL
Washington, DC 20585

Alex O. Bulawka
U.S. Department of Energy
1000 Independence Ave. SW
EE-11 FORSTL
Washington, DC 20585

Dan T. Ton
U.S. Department of Energy
1000 Independence Ave. SW
EE-11 FORSTL
Washington, DC 20585

J. A. Mazer
U.S. Department of Energy
1000 Independence Ave. SW
EE-11 FORSTL
Washington, DC 20585

Joe Galdo
U.S. Department of Energy
1000 Independence Ave. SW
EE-10 FORSTL
Washington, DC 20585

Kenneth L. Heitner
U.S. Department of Energy
1000 Independence Ave. SW
EE-32 FORSTL
Washington, DC 20585

Russ Eaton
U.S. Department of Energy
Golden Field Office
1617 Cole Blvd., Bldg. 17
Golden, CO 80401

W. Butler
U.S. Department of Energy
1000 Independence Ave. SW
PA-3 FORSTL
Washington, DC 20585

Gary A. Buckingham
U.S. Department of Energy
Albuquerque Operations Office
P.O. Box 5400
Albuquerque, NM 87185

Edward Beardsworth
UFTO
951 Lincoln Avenue
Palo Alto, CA 94301-3041

John H. Price
University of Texas at Austin
J.J. Pickel Research Campus
Mail Code R7000
Austin, TX 78712

Steve Hester
Utility Photo Voltaic Group
1800 M Street NW
Washington, DC 20036-5802

Rick Ubaldi
VEDCO Energy
12 Agatha Lane
Wayne, NJ 07470

Randy Bevin
Walt Disney World
Design and Eng'g
P.O. Box 10,000
Lake Buena Vista, FL 32830-1000

Tom Matty
Westinghouse
P.O. Box 17230
Maryland, MD 21023

Philip N. Overholt
U.S. Department of Energy
1000 Independence Ave. SW
EE-11 FORSTL
Washington, DC 20585-0121

Richard J. King
U.S. Department of Energy
1000 Independence Ave. SW
EE-11 FORSTL, 5H-095
Washington, DC 20585

James E. Rannels
U.S. Department of Energy
1000 Independence Ave. SW
EE-11 FORSTL
Washington, DC 20585-0121

Wayne Taylor
U.S. Navy
Code 83B000D, NAWS
China Lake, CA 93555

Max Anderson
University of Missouri - Rolla
112 Electrical Eng. Bldg.
Rolla, MO 65401-0249

G. Alan Palin
Urenco (Capenhurst) Ltd.
Capenhurst, Chester, CH1 6ER
UNITED KINGDOM

Mike Stern
Utility Power Group
9410-G DeSoto Avenue
Chatsworth, CA 91311-4947

Gary Verno
Virginia Power
Innsbrook Technical Center
5000 Dominion Blvd.
Glen Ellen, VA 23233

Gerald J. Keane
Westinghouse Elec. Corp.
Energy Management Division
4400 Alafaya Trail
Orlando, FL 32826-2399

Howard Saunders
Westinghouse STC
1310 Beulah Road
Pittsburgh, PA 15235

Frank Tarantino
Yuasa, Inc.
2366 Bernville Road
P.O. Box 14145
Reading, PA 19612-4145

Nicholas J. Magnani
Yuasa, Inc.
2366 Bernville Road
P.O. Box 14145
Reading, PA 19612-4145

Robert J. Parry
ZBB Technologies, Ltd.
16 Emerald Tce.
West Perth, 6005
WESTERN AUSTRALIA

Gene Cook
Yuasa, Inc.
2366 Bernville Road
P.O. Box 14145
Reading, PA 19612-4145

R. Kristiansen
Yuasa-Exide, Inc.
35 Loch Lomond Lane
Middleton, NY 10941-1421

Phillip A. Eidler
ZBB Technologies, Inc.
11607 West Dearbourn Ave.
Wauwatosa, WI 53226-3961