

THE ADVANCED PHOTON SOURCE

A National Synchrotron Radiation Research Facility

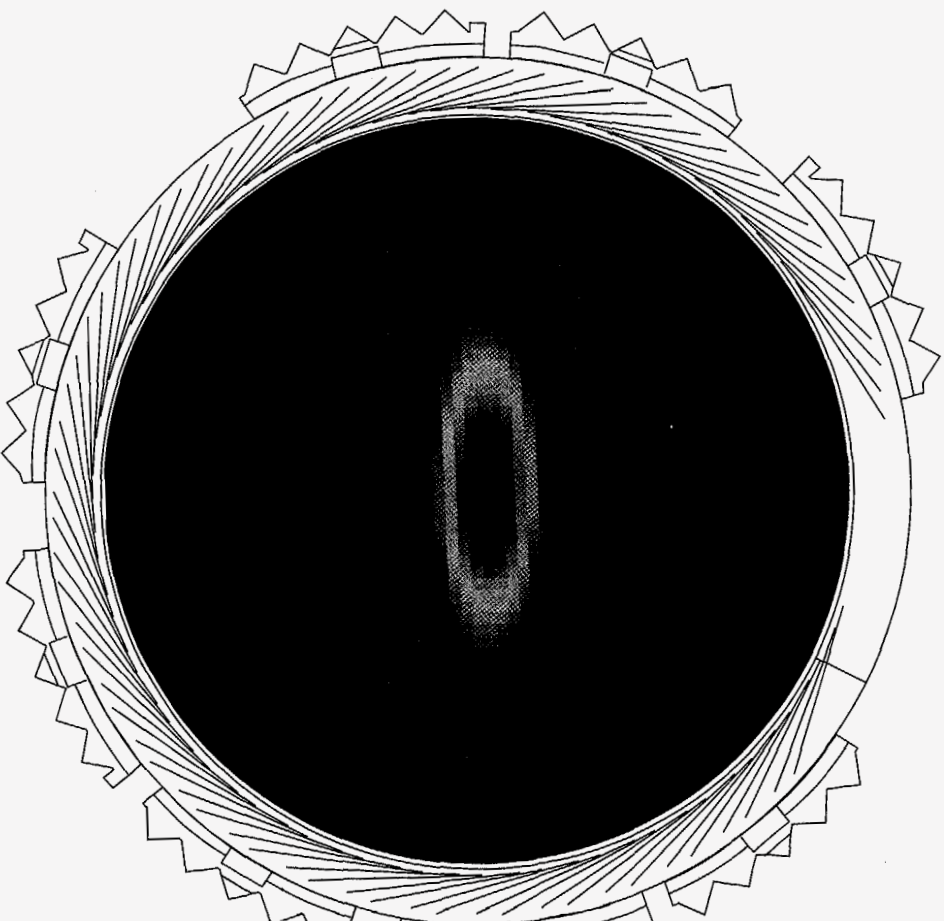

DISCLAIMER

This report was prepared as an account of work sponsored by an agency of the United States Government. Neither the United States Government nor any agency thereof, nor any of their employees, makes any warranty, express or implied, or assumes any legal liability or responsibility for the accuracy, completeness, or usefulness of any information, apparatus, product, or process disclosed, or represents that its use would not infringe privately owned rights. Reference herein to any specific commercial product, process, or service by trade name, trademark, manufacturer, or otherwise does not necessarily constitute or imply its endorsement, recommendation, or favoring by the United States Government or any agency thereof. The views and opinions of authors expressed herein do not necessarily state or reflect those of the United States Government or any agency thereof.

AT

ARGONNE NATIONAL LABORATORY

OCTOBER 1995

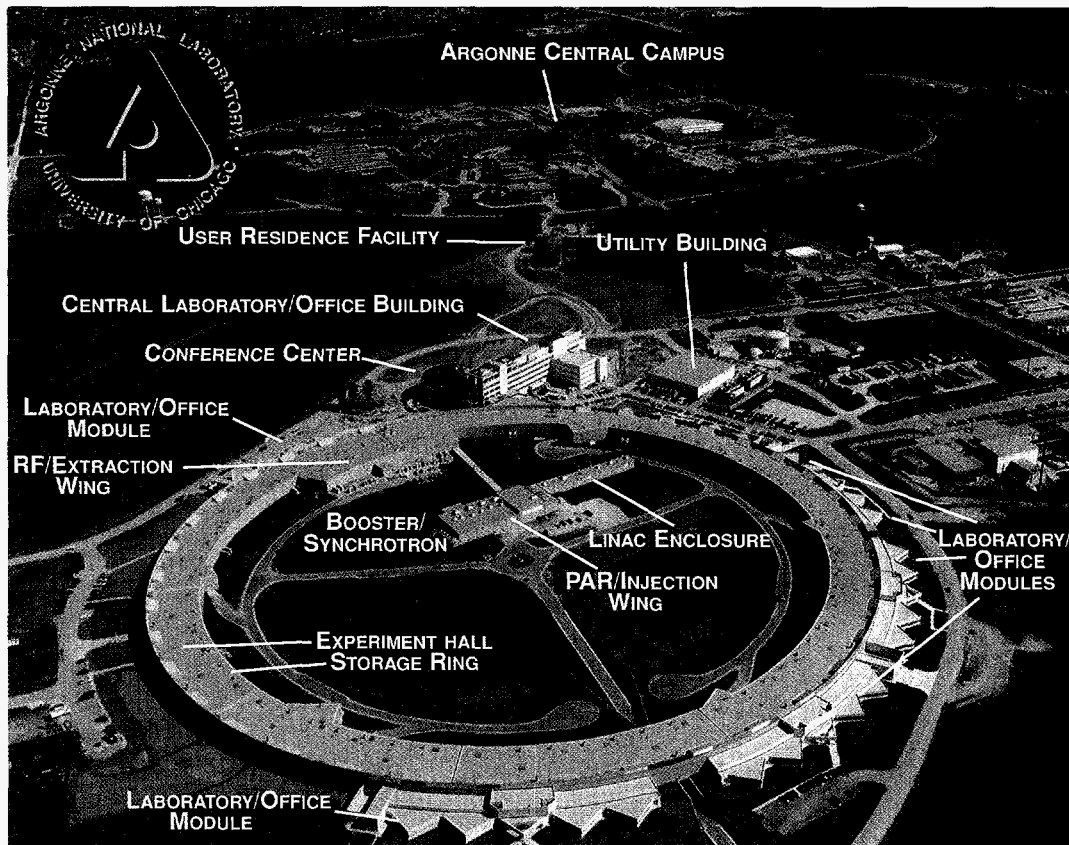

Aerial view of Argonne National Laboratory and the Advanced Photon Source as of September 21, 1995.

When the Department of Energy received Congressional funding to construct the Advanced Photon Source, the proposed date for operation was summer of 1996. After budget constraints forced funding reductions in 1992, the official date slipped by six months. But for all of us who have worked on this project, the date for first operations was not set by the DOE, nor by Congress, but by Wilhelm Conrad Röntgen — who discovered the x-ray in November of 1895. Following in his footsteps, we have pursued the mandate to construct this facility with two goals in mind: to make it work before the 100th anniversary of Röntgen's discovery, and to make it worthy of that accomplishment. We are very proud that the first APS undulator x-ray beam was produced on August 9, 1995, meeting or exceeding virtually all specifications. The focus now shifts to scientific research.

The vision of the APS sprang from prospective users, whose unflinching support the project has enjoyed throughout the decade it has taken to make this facility a reality. Perhaps the most extraordinary aspect of synchrotron radiation research, is the extensive and diverse scientific makeup of the user community. From this primordial soup of scientists exchanging ideas and information, come the collaborative and interdisciplinary accomplishments that no individual alone could produce. So, unlike the solitary Röntgen, we are engaged in a collective and dynamic enterprise with the potential to see and understand the structures of the most complex materials that nature or man can produce — and which underlie virtually all our modern technologies.

I sincerely hope that this booklet provides scientists and laymen alike with a sense of both the extraordinary history of x-rays and the knowledge they have produced, as well as the potential for future discovery contained in the APS — a source a million million times brighter than the Röntgen tube.

David E. Moncton
Associate Laboratory Director, Advanced Photon Source
October 1995

DISCLAIMER

Portions of this document may be illegible in electronic image products. Images are produced from the best available original document.

TABLE OF CONTENTS

PLAN VIEW OF THE ADVANCED PHOTON SOURCE	2
OVERVIEW OF THE ADVANCED PHOTON SOURCE	3
WILHELM CONRAD RÖNTGEN	4
EXPERIMENTERS & THE ADVANCED PHOTON SOURCE	5
X-RAY RESEARCH TECHNIQUES: A PRIMER	6
MATERIALS SCIENCE	8
BIOLOGICAL SCIENCE	10
ENVIRONMENTAL, AGRICULTURAL & GEOSCIENCE	12
CHEMICAL SCIENCE	14
ATOMIC, MOLECULAR & OPTICAL PHYSICS	15
MEDICAL SCIENCE	16
MICROMANUFACTURING	17
SYNCHROTRON RADIATION & INSERTION DEVICES	18
TECHNICAL SYSTEMS	20
The APS Beam Acceleration & Storage System	20
Controls Software & Particle-Beam Diagnostics	22
Beamline Front Ends	23
User Beamlines & Optics	24

On the cover: A fluorescent-screen image of 18.3-keV, single-wavelength radiation from APS Undulator A. The radiation energy was selected by a monochromator located in the first optics enclosure of beamline 1-ID in the APS experiment hall.

ANL/APS/TB-25

October 1995

Distribution Category: Atomic, Molecular, and Chemical Physics (UC-411)

This document was prepared as an account of work sponsored by an agency of the United States Government. Neither the United States Government nor any agency thereof, nor any of their employees, makes any warranty, express or implied, or assumes any legal liability or responsibility for the accuracy, completeness, or usefulness of any information, apparatus, product, or process disclosed, or represents that its use would not infringe privately owned rights. Reference herein to any specific commercial product, process, or service by trade name, trademark, manufacturer, or otherwise, does not necessarily constitute or imply its endorsement, recommendation, or favoring by the United States Government or any agency thereof. The views and opinions of authors expressed herein do not necessarily state or reflect those of the United States Government or any agency thereof.

Argonne National Laboratory, with facilities in the states of Illinois and Idaho, is owned by the United States Government and operated by The University of Chicago under the provisions of contract W-31-109-Eng-38 with the U.S. Department of Energy.

DISTRIBUTION OF THIS DOCUMENT IS UNLIMITED

MASTER

This "plan view" shows the Advanced Photon Source, located on 80 acres at Argonne National Laboratory. Seventy-two prime- and subcontractors worked more than two million man-hours (over 1000 man-years) to complete the APS buildings. An aggressive construction safety program resulted in an accident rate 1/4 that of the U.S. indices for similar work, with no serious injuries and no fatalities.

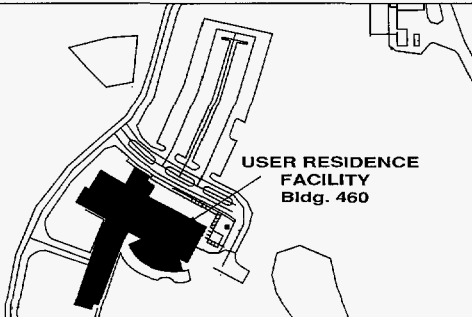

A 6-story, 240-bed residence for researchers and students is within a few hundred meters of the APS experiment hall. The residence building was completely funded by the State of Illinois. Visitors can walk to their offices and experiments, while fiber-optic connections between the residence and the experiment hall permit real-time monitoring of experimental apparatus.

A six-story central lab/office building provides offices, a library, a seminar room, and laboratories for APS staff. Scientific conferences and workshops are held in an adjoining conference center that can seat 538 people in the main lecture hall and flexible-size meeting rooms.

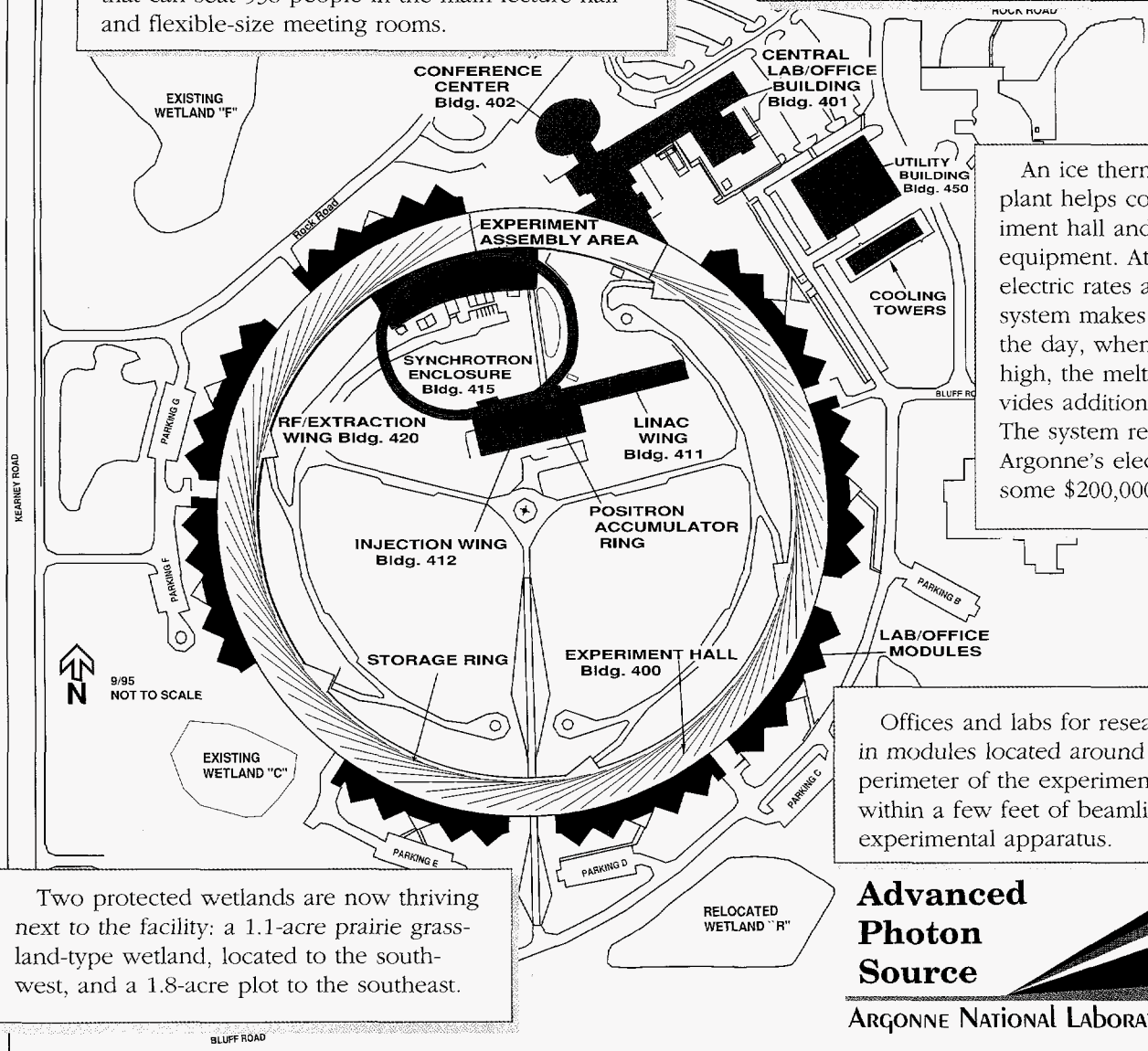

An ice thermal storage plant helps cool the experiment hall and accelerator equipment. At night, when electric rates are low, the system makes ice. During the day, when rates are high, the melting ice provides additional cooling. The system reduces Argonne's electric bill by some \$200,000 annually.

Offices and labs for researchers are in modules located around the outer perimeter of the experiment hall, within a few feet of beamlines and experimental apparatus.

Two protected wetlands are now thriving next to the facility: a 1.1-acre prairie grass-land-type wetland, located to the southwest, and a 1.8-acre plot to the southeast.

Advanced Photon Source
 ARGONNE NATIONAL LABORATORY

THE ADVANCED PHOTON SOURCE AT ARGONNE NATIONAL LABORATORY

Imagine a research laboratory where completely new scientific tools are available for use from the first day of experimentation. And suppose that this experimentation is carried out in a facility designed by and for the people who will be using it, where every decision was based on making research as efficient and expeditious as possible. A place where 2000 scientists each year from universities, industries, medical schools, and research labs (federal and otherwise) can conduct frontier science, both basic and applied, across a wide range of scientific disciplines. A common ground where interaction and synergy between materials scientists and molecular biologists, agricultural and environmental scientists, chemists and crystallographers can occur on the experiment hall floor or in offices, labs, or at cafeteria tables.

That was the vision contained in a 1984 report prepared by a scientific committee convened by the U. S. Department of Energy (DOE), Office of the Basic Energy Sciences, to "solicit and evaluate ideas from synchrotron-radiation providers and users as to the future opportunities and technical needs for synchrotron-radiation-based research." The committee report stated that "current research programs in materials science, physics, biology, chemistry, geosciences, and other fields that use synchrotron radiation could greatly benefit from the availability of high-brilliance x-ray beams" and identified as its highest priority the construction of a machine optimized to produce x-ray beams of unprecedented brilliance. That recommendation was affirmed by the Major Materials Facilities Committee of the National Academy of Sciences, the National Research Council, and by two subcommittees of the DOE Energy Research Advisory Board. The facility that resulted from those recommendations is the Advanced Photon Source (APS) at Argonne National Laboratory.

Several years of detailed facility design and management planning ensued. In June of 1990, the DOE granted Project status and full funding to the APS, and ground-breaking ceremonies marked the start of construction.

Five years later, on the evening of August 9, 1995, the first x radiation flashed down a beamline to a detector on the APS experiment hall floor. The APS had produced this extremely intense, laser-like beam of x-rays ahead of schedule and well within original budget estimates.

The x-ray beam is one of the best research tools available to science. It is a highly penetrating light ideally suited to a broad range of applications. Most of what we know about the three-dimensional arrangement of atoms in materials from elements to catalysts, from DNA to viruses has come from x-ray crystallographic research. Synchrotron x-ray sources have allowed scientists to conduct molecular-level examinations of semiconductor surfaces and organic thin films, both of which are essential to the development of designer materials for new technologies.

Sources of synchrotron radiation for scientific inquiry have become essential to industrialized nations; more than 40 are either under construction or in operation worldwide. These facilities offer scientists access to an extensive variety of research techniques that can be used in almost any discipline where the subjects to be studied are the material substances of our world. The DOE has funded the Advanced Photon Source with confidence that the APS will carry out research well into the 21st century, and be a sound investment in this nation's scientific, technological, and economic future. ●

WILHELM CONRAD RÖNTGEN —

“The experiment is the most powerful and most reliable lever enabling us to extract secrets from nature ...”

On the evening of Friday, November 8, in 1895, Wilhelm Conrad Röntgen was, as he told a reporter for *McClure's Magazine*, pursuing his interest in “the cathode rays from a vacuum tube.” Röntgen's laboratory at the University of Würzburg was dark as he passed electrical current through a Hittorf-Crookes tube covered with black cardboard. Looking up, he saw “at each discharge a bright illumination” on a piece of barium platinocyanide-impregnated paper lying on a nearby bench. “The effect was one which could only be produced ... by the passage of light. No light could come from the tube, because the shield which covered it was impervious to any light known.”

“And what did you think?” the reporter inquired.

“I did not think,” replied Röntgen, “I investigated.”

He was an unlikely prospect to win the first Nobel prize for physics. Born in 1845 to a family of merchants, traders, and musicians, he was a mediocre student; several universities rejected his applications for admission. After finally enrolling at the Polytechnical School in Zürich, he took only one course in physics — and not a single class in experimental physics. In 1869, after years of struggle, he earned both a doctorate and an engineering degree.

Freed from the constraints of a formal curriculum, he opted for a career in the physical sciences and studied physics on his own. He proved to be a gifted scientist, a well-disciplined researcher and observer with a rich knowledge of his scientific predecessors and their accomplishments. His successes eventually brought him, in 1894, the position of rector for the new physical institute at the University of Würzburg. There he assembled his modest but precise laboratory, equipped with instruments most of which he made.

After his encounter with the unexplained fluorescence, Röntgen spent the rest of 1895 on intense investigations. He passed rays through a host of materials: a single sheet of paper; a 1000-page book; tinfoil; blocks of wood; aluminum, copper, lead, gold, and platinum plates; glass plates, with and without lead; hard rubber; water, carbon disulfide, “and various other liquids.” He made x-ray photographs of everyday objects: a door, a compass, a box of weights, and his wife's hand. “We soon discover that all bodies are transparent to this agent, though in very different degrees,” he wrote in *On a new kind of rays*, the first formal communication of his discovery. Röntgen delivered his manuscript to the president of the Physical Medical Society of Würzburg on December 28. For brevity, Röntgen chose “rays” to describe the light. To distinguish them from others, he called them “X-rays.”

Within weeks, Röntgen's paper was translated and

published all over the world, which seemed to be bathed in a fluorescent glow of excitement. His experiments were easily reproduced and confirmed due to the prevalence of Hittorf-Crookes' tubes in laboratories. The scientific community and the general public developed an insatiable appetite for x-ray images, of hands in particular, although some were repelled by the “images of death.” A Röntgen biographer theorized that images of bones hastened the impact of the discovery. It is clear that fascination with bone shadows quickly led to the use of x-rays as a diagnostic tool.

While Röntgen chose to study the light itself, scientists in nearly every discipline rushed to apply x-rays. Reports of related discoveries and applications flowed to the scientific journals. (The arts and the military and legal professions also embraced the new photography; interest was expressed by opponents of vivisection and by proponents of temperance, spiritualism, fortune telling, and telepathy — even alchemy.) The photofluoroscope was developed, improving x-ray imaging. A hand amputated from a corpse was injected with a mixture of lime, cinnabar, and petroleum and x-rayed for 57 minutes, revealing all of the veins in detail. The mechanics of limb movement were recorded on 40 feet of cinematograph film exposed to x-rays penetrating a frog's leg. X-ray examinations were made of welds and castings. Food and wine were probed to detect adulterants. The new light revealed phosphates in porcelains and gold in quartz; the inner structures of plants, animals, and mummies; and the relative transparencies of real and ersatz precious stones. Chemical effects of the rays were studied in exhaustive detail. All of this, and more, in one year. The universal impact of x-ray science was clear by the end of 1896.

In the 100 years since Röntgen, there has been a trillion-fold increase in the brilliance of x-ray sources for research. That increase has come in the last 25 years, mainly through the use of electron storage rings to provide synchrotron radiation. Today, the demand for accelerator-based x-ray sources is worldwide. New facilities, like the APS, dedicated to the production of high-brilliance x-ray beams provide the tools scientists will use to answer questions about the materials that underlie our technologies, our economies, and our day-to-day lives. This would certainly have pleased Röntgen, the constant experimenter. One month before his death in 1923, he wrote: “I would very much like to finish an experimental investigation which I started many months ago, but the walk to the laboratory has gradually become too burdensome... I am going to try to make a fresh start.” ●

EXPERIMENTERS & THE ADVANCED PHOTON SOURCE

The Advanced Photon Source is a center of interaction for hundreds of scientists affiliated with universities, industrial firms, national laboratories, medical schools, and other research institutions, both private and federal. Since 1983, potential users from various scientific disciplines have been helping design the facility to meet their needs. They provided ideas about important technical and non-technical issues, from the type and quality of the radiation required to the environment in the experiment hall.

Scientists may utilize the APS either as members of Collaborative Access Teams (CATs) or as Independent Investigators. Collaborative Access Teams comprise large numbers of investigators with common research objectives. These teams are responsible for the design, construction, funding and operation of beamlines designed to take radiation from the APS storage ring and tailor it to meet specific experimental needs. Collaborative Access Teams must allocate a percentage of their beam time to Independent Investigators, unaffiliated individuals or groups whom the CATs select through proposal approval.

Each CAT enters into an agreement with the APS, in the form of a Memorandum of Understanding (MOU). Before an MOU can be finalized, prospective CATs must pass a rigorous approval process designed to assure that the resources of the APS are used to maximum advantage.

A Proposal Evaluation Board (PEB), consisting of six distinguished scientists, evaluates research proposals from prospective CATs. The PEB considers the scientific and technical merit of the research and the degree to which it will use the state-of-the-art capabilities of the APS. The PEB receives input from one of several scientific review panels and from independent reviewers with expertise in the specific areas of interest. The PEB weighs the probability of accomplishing stated objectives, the qualifications and experience of the CAT members, the feasibility of the beamline design, and a management plan. The PEB also evaluates the team's strat-

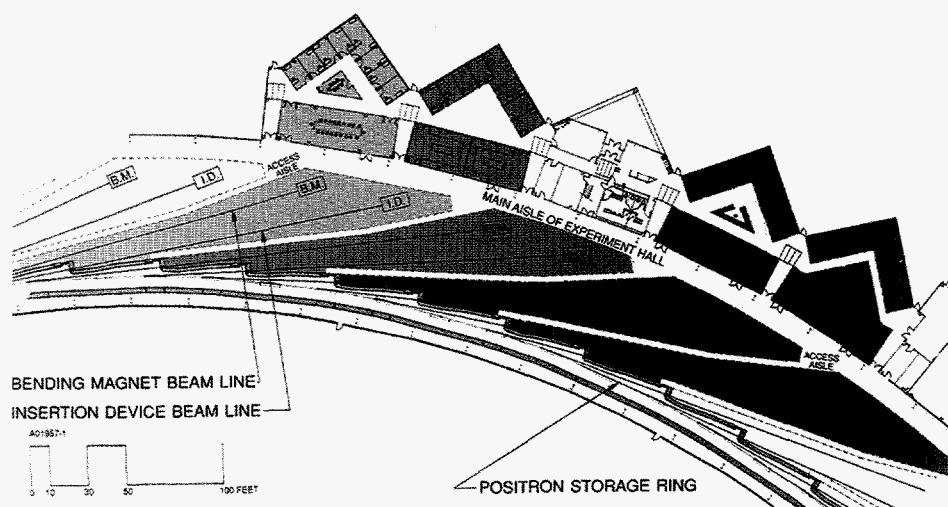

The diagram above shows the division of the APS experiment hall into sectors, with each sector adjoining its respective user laboratory/office module on the perimeter of the experiment hall building.

egy for financing beamline construction, which can cost from \$2 million to \$10 million each. These funds come from several sources, including the Department of Energy, the National Science Foundation, private industry, the National Institutes of Health, universities, state legislatures, National Institute for Standards and Technology, the Department of Agriculture, and foundation grants.

Finally, the PEB attempts to balance approved proposals so that a number of scientific disciplines are represented at the APS. The PEB then makes recommendations to APS management, which has responsibility for CAT selection.

Scientists conducting nonproprietary research (the results of which are published in open literature) are not charged for basic operating costs, such as maintenance and utility costs for the experimental hall, nor for beam time. In accordance with DOE policy, users doing proprietary research reimburse the APS for beam time.

Each year, more than 2000 researchers will work on experiments when all 70 APS beamlines are implemented. The APS provides an environment in which researchers from different institutions, disciplines, and career stages can work together. University professors and students will interact daily with colleagues from industry and national laboratories, exchanging ideas both formally and informally through collaborations, seminars, and impromptu discussions. These symbiotic relationships will pay real dividends in enhanced research quality and scientific productivity. ●

X-RAY RESEARCH TECHNIQUES: A PRIMER

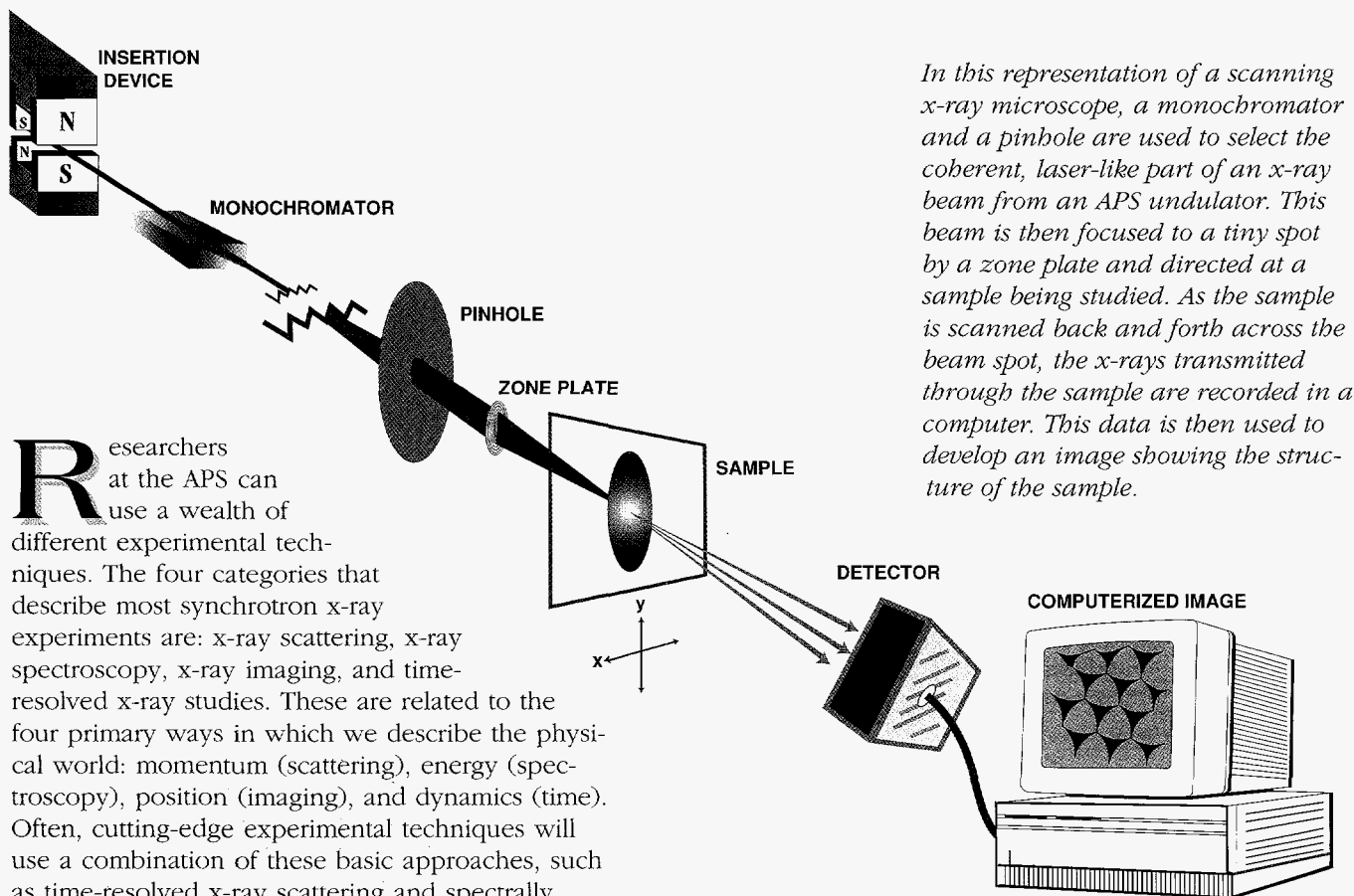

In this representation of a scanning x-ray microscope, a monochromator and a pinhole are used to select the coherent, laser-like part of an x-ray beam from an APS undulator. This beam is then focused to a tiny spot by a zone plate and directed at a sample being studied. As the sample is scanned back and forth across the beam spot, the x-rays transmitted through the sample are recorded in a computer. This data is then used to develop an image showing the structure of the sample.

Researchers at the APS can use a wealth of different experimental techniques. The four categories that describe most synchrotron x-ray experiments are: x-ray scattering, x-ray spectroscopy, x-ray imaging, and time-resolved x-ray studies. These are related to the four primary ways in which we describe the physical world: momentum (scattering), energy (spectroscopy), position (imaging), and dynamics (time). Often, cutting-edge experimental techniques will use a combination of these basic approaches, such as time-resolved x-ray scattering and spectrally selected imaging.

- Imaging is the most familiar technique. Nearly everyone has had some experience with x-ray pictures taken of the human body and used for medical diagnosis. For centuries, optical microscopes have provided an invaluable, often inspirational, window onto the microscopic world. Modern holograms simulate three-dimensional images in two dimensions using the coherent properties of lasers.

Many forms of imaging that use x-ray beams have been developed, including tomography, topography, microscopy, and holography. In x-ray microscopy, beams are focused to a small point on the sample and the intensity of transmitted or reflected x-rays (or some other signal) is recorded as the sample is scanned back and forth across the focused x-ray spot. This produces a micrograph of the sample with a resolution limited only by the spot size that can be produced by focusing the x-rays. The undulator x-ray sources at the APS permit focal spots to be much smaller while increasing the

intensity of the spot. Thus, improved resolution and higher sensitivity are possible.

X-ray tomography captures ordinary two-dimensional x-ray pictures at several different orientations and uses computers to construct a three-dimensional image of the sample. X-ray beams at the APS improve the resolution and sensitivity of tomography in basic and applied research applications. And by using monochromators to select different x-ray wavelengths, it is possible to tune the x-rays to detect particular atoms, allowing selective imaging of different sample components.

- In x-ray scattering experiments, an x-ray beam is passed through a sample, and the intensities and directions of the scattered x-rays are measured. The pattern of scattered x-rays is converted by computer into information about the arrangements of atoms in the sample. There are many types of x-ray scattering experiments. Perhaps the most common is x-ray diffraction, used in the field of crystallogra-

phy to determine the regular placement of atoms in crystals. Breakthroughs in many disciplines, from materials science to biotechnology, will depend upon our understanding of how the specific arrangements of atoms in a sample determine its physical, chemical, or biological behavior. This is called the "structure-function relationship."

We use x-rays to "see" where the atoms are in materials because the wavelength of the scattered radiation limits the resolution of the derived structure, and x-ray wavelengths are the size of atoms or even smaller. The APS is of vital importance because its brilliance extends the use of x-ray scattering techniques to many types of technologically critical samples that would not be visible using earlier x-ray sources. Many of the new studies done at the APS involve extremely tiny, submicron samples, thin targets at surfaces and interfaces, and samples with low density and/or scattering cross sections.

In x-ray scattering experiments, an x-ray beam is passed through a sample, and the intensities and directions of the scattered x-rays are measured. The pattern of scattered x-rays is converted by computer into information about the arrangements of atoms in the sample.

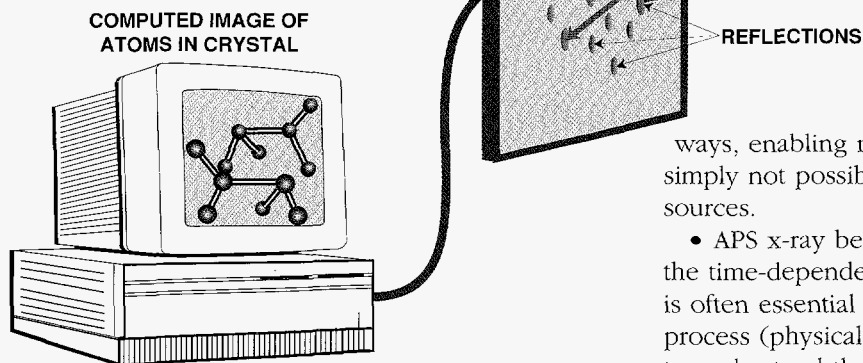

- In x-ray spectroscopy experiments, a beam of x-rays passes through a sample and a measurement is made of the degree to which x-rays of different energies are absorbed by the sample. This information is contained in a spectrum, which expresses the degree of x-ray absorption (or some other measured quantity) on one axis versus the x-ray energy on the other axis. A widely used type of x-ray spectroscopy is called extended x-ray absorption fine structure, or EXAFS. In EXAFS spectra, weak oscillations indicate the effect of scattering from neighboring atoms by an electron ejected from the atom that absorbs an x-ray. Here, we are observing electron scattering effects rather than the x-ray scattering effects described above.

The weak oscillations in an EXAFS spectrum can be analyzed using simple computer models to provide researchers with precise information about the number and placement of atoms in the immediate vicinity of the atom that absorbs the x-ray. Using this information, the researcher can relate the physical, chemical, or biological properties of a sample to its atomic constituents and their relative positions. This is another way of determining the "structure-function" relationship mentioned above. X-ray beams provided by the APS improve spectroscopic studies in several important

ways, enabling many important studies that are simply not possible with previously available x-ray sources.

- APS x-ray beams can also be used to explore the time-dependence, or dynamics, of processes. It is often essential to learn the time history of a process (physical, chemical, or biological) in order to understand that process well enough to exploit it for scientific or engineering purposes.

Because APS x-ray beams travel down a beamline in short bursts lasting only 60 billionths of a second, it is possible to observe changes taking place in time intervals much shorter than those possible with earlier x-ray sources.

Typically, some characteristic of a sample (diffraction pattern, EXAFS spectrum, etc.) is measured at different time delays following a small change in the sample (laser pulse, pressure increase, temperature increase). In this way, the mechanisms by which a system responds to sudden changes can be measured. These questions affect issues from the physical properties of new materials to the operation of a single biological cell. ●

MATERIALS SCIENCE

A primary mission of the APS is to facilitate a materials science revolution that will help ensure U.S. economic competitiveness through the next century. Just as the Industrial Revolution was sparked by the invention of steel, future technological revolutions will hinge on the invention of new or improved semiconductors, polymers, ceramics, superconductors, composites, metallic glasses, and artificially layered structures. These materials will find applications in computing, microminiaturization, robotics, space exploration, communications, manufacturing, and energy technologies.

X-ray beams from the APS can reveal the precise positions of atoms in materials. This information lays the foundation for our understanding of how atomic structure influences the properties of materials and yields the principles used in engineering new materials tailored to specific applications. Research at the APS can also provide a wealth of data about the magnetic and electronic structure of new materials and their usefulness in advanced technologies.

Recently discovered superconducting ceramics lose all resistance to electricity at temperatures approaching 200 degrees Kelvin. Previously, superconductors operated at the temperature of liquid helium (4 degrees Kelvin). It is of great practical importance that superconductors operate well above the temperature of the much cheaper liquid nitrogen (77 degrees Kelvin). These "high-temperature superconductors" promise new applications in electronics, power transmission, and transportation. Superconducting ceramics are expected to be the future "silicon chips" of the communications, space, and auto industries. Ceramic optical fibers are already being used for information transmission, and ceramic mirrors have been designed for tele-

scopes to be used in future space shuttles.

But before this potential can be realized, scientists must gain a better understanding of how these materials behave during their high-temperature formation. The ability to sharply focus the brilliant x-ray beams from the APS permits researchers to examine the internal structures of ceramics under

the most extreme conditions, such as ultra-high temperature and pressure.

Another example is provided by metallic glasses. These materials, which are formed when molten metals solidify rapidly, are thousands of times stronger than the materials used in present-day technologies. Their unusual strength is related to the "tangled" arrangement of their atoms, which are not yet fully understood. The APS will enable scientists to focus on this atomic detail, relate tangled structure to

enhanced strength, and use this knowledge to predict the structures of even stronger materials.

Polymers are used everywhere, from the plastics in ordinary home furnishings to the specialized materials for aircraft and space vehicles. X-ray techniques applied to polymer science span the entire spectrum, from characterization of the polymerization process, to the dependence of the polymer product on manufacturing conditions, to the study of mechanical properties (fracturing and crazing) of the finished product. The brilliance of APS x-ray beams is critical to this field because polymers are hard to "see" with the x-rays from previous sources. The answers to many key questions in polymer science can only be found by using cutting edge x-ray technology.

Materials scientists can also use the APS to develop new "soft" materials, which are actually complex fluids. Examples of these are cosmetics, lubricants, paints, adhesives, food additives, and ingredients in

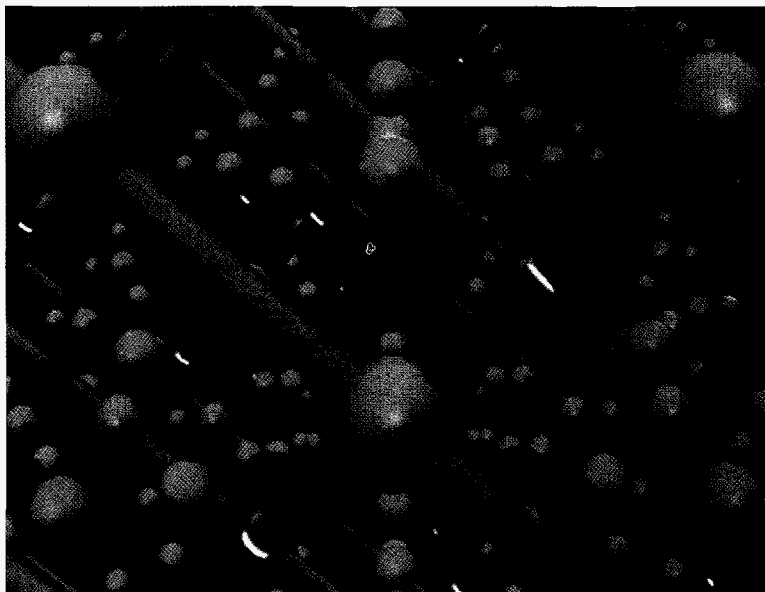

Scientists will use the brilliant x-ray beams from the APS to determine the three-dimensional arrangement of atoms in new materials. Shown here is a computer simulation of the three-dimensional structure of the high-temperature superconductor X.

tires, oil recovery, drug delivery systems, and environmental remediation. Complex fluids are actually solutions or melts. These are made up of large molecules or molecular aggregates that organize themselves into flexible but specific structures with unique and useful properties. Over the last few decades, science has gained a better understanding of the microscopic structure of these fluids in their various phases, and the nature of the interactions between the molecules that control their unique behavior. This knowledge has been obtained with a variety of research techniques, among which x-ray scattering has been particularly important. The high brilliance of the APS should, for the first time, make possible studies of how the structure of these fluids changes dynamically under external stresses, flows, or confinement. These are the conditions present when soft materials are actually applied in industrial processes.

Research at the APS will have a major impact on the study and improvement of surfaces, interfaces, thin layers, and artificially layered structures. All of these two-dimensional structures are now used for computers, telecommunications, data storage, energy conversion, protective coatings, lubricants, adhesives, catalysts, and batteries. Thin-film magnetism research, one of the frontiers of basic materials science, is expected to have a significant impact on the information age by improving magnetic data storage techniques. The study of thin-film magnetism at the APS will be greatly aided by a new elliptical multipole wiggler, an insertion device co-developed by scientists from the APS, Brookhaven National Laboratory, and the Russian Institute of Nuclear Physics at Novosibirsk. This device will provide the type of intense, circularly polarized radiation so useful in probing magnetic interactions.

Although the technological and economic impact of surfaces and interfaces has already been tremendous, the major gains in and applications of these materials lie ahead. They can only be realized by increasing our understanding of and control over the atomic structure, kinetics, and growth of these thin but critical structures.

There is an immediate need for new techniques that can probe materials with submicron (1 micron = 10^{-6} meters) spatial resolution and part-per-billion (ppb) sensitivity for trace species. At the APS, research techniques such as x-ray microdiffraction, microfluorescence, and microtomography are capable of submicron spatial resolution and ppb sensi-

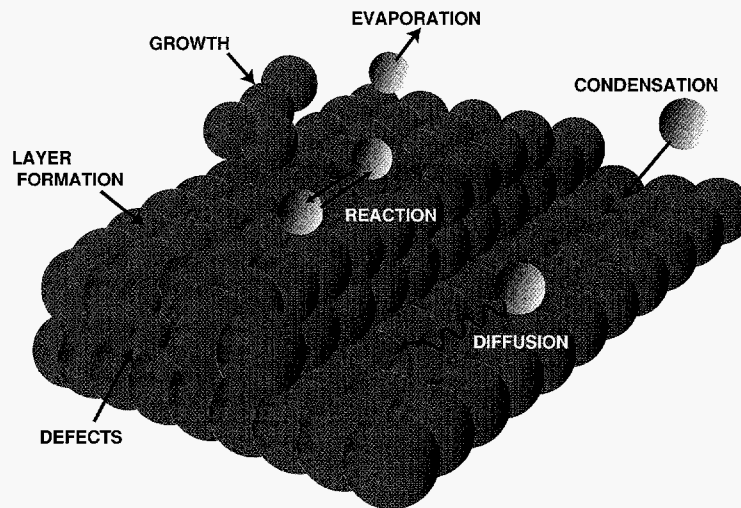

Developments in condensed-matter physics have been stimulated by the demand for new materials with improved properties. Condensed matter embodies in its conceptual framework four physical quantities — energy, momentum, time, and space.

tivity for microprobe analysis in a broad range of materials applications. The APS delivers an x-ray beam with a brilliance four orders of magnitude greater than that of previous synchrotron radiation sources and ten orders of magnitude greater than laboratory sources. These x-ray microprobes offer distinct advantages over electron microprobes, because x-rays are selective, penetrating, and less destructive than electrons. Scientists using the APS can perform diffraction studies on materials (such as catalysts) that are only available in micron-sized crystals; to image impurities in submicron-sized regions of integrated circuits; to create three-dimensional images of microporous materials; and to image micron-sized cracks in polymers, ceramics, and alloys.

Add to this list of advantages the time structure of APS x-ray beams (which arrive in pulses that last only billionths of a second), and one has the ultimate probe for development of complex materials — a probe with time, spatial, and species resolution capable of penetrating any material and analyzing components with a high degree of sensitivity. All of the subjects mentioned here can be studied as they evolve in time, a dimension that is often central to understanding the critical mechanisms responsible for the behavior of a material. The APS can create computer-generated “motion pictures” of materials processes occurring at the atomic level. These processes include the mechanisms of growth, phase changes, solid-state reactions, crack propagation, polymer hardening, interface processes, and other time-dependent processes. Fast detectors and instrumentation for time-resolved scattering, spectroscopy and real-space imaging are being developed to take advantage of these opportunities. ●

What do walking, thinking, inherited traits in children, normal or cancerous cell growth, infections, drug treatment, and bioremediation have in common? They all depend upon reactions between two large biological molecules, comprising many thousands of atoms, that can occur only when reacting molecules fit together like the pieces of a complex, three-dimensional jigsaw puzzle. This is because evolution has made the processes of life

highly selective. The reactive sites of molecules are hidden in complex molecular terrains. These reactive sites will touch only if two molecules have exactly the right shape. The reactive site on one molecule might be hidden in a deep crevasse, and a reaction can only occur with a molecule that has an appropriate reaction site on a matching peak.

By determining the detailed shapes of biomolecules, we can understand and even control their biological function. This "form and function" relationship is the central goal of structural biology, and it plays an increasingly important role in medicine, the pharmaceutical industry, and biotechnology. The overwhelming preponderance of available information regarding the three-dimensional arrangement of atoms in proteins, nucleic acids (DNA and RNA), and viruses has been obtained by

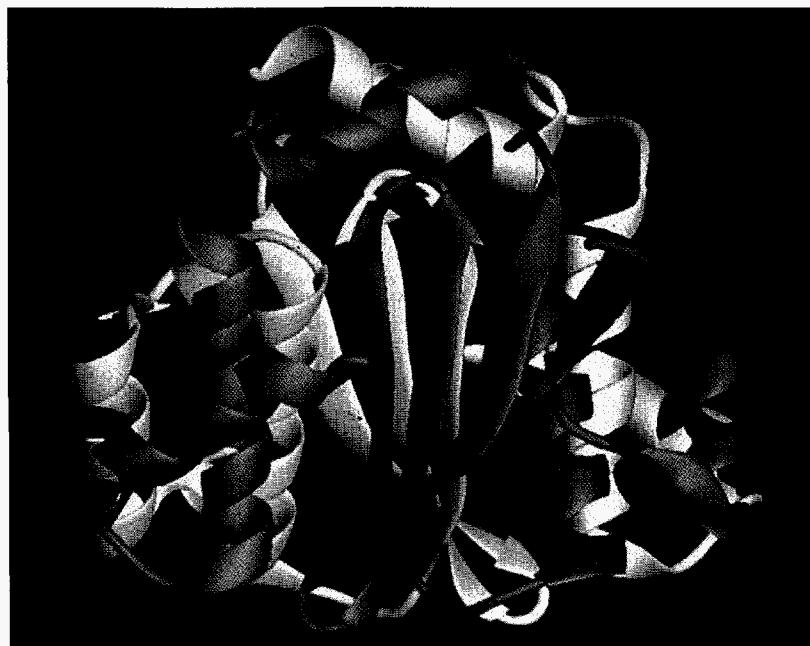

A ribbon representation of the dimer formed by the catalytic core domain of HIV-1 Integrase. This crystal structure was solved at 2.3 Å resolution by combining multiwavelength anomalous diffraction and multiple isomorphous replacement methods using synchrotron x-ray radiation. This is the first three-dimensional structural data obtained on any retroviral integrase. The HIV integrase breaks a human gene and places the viral gene into the sequence for replication. Only through the use of synchrotron x-ray radiation can these structures be determined. (Courtesy David Davies/National Institutes of Health. Image based on data collected on beamline 4A at the National Synchrotron Light Source, Brookhaven National Laboratory.)

diffracting x-rays from single crystals of these materials. But the progress to date is just prelude to a renaissance in molecular biology and other areas of the biological sciences brought on by new x-ray source technology, such as the APS.

Although much attention in structural biology is directed toward DNA, RNA, and the genetic code in genes and chromosomes, the most intense research is focused on proteins. This interest is explained by the ubiquity, variety, and diverse biological roles of pro-

teins. They transport oxygen in the blood and transmute sunlight into life-giving carbohydrates. They defend us against infection and serve as the structural building blocks of muscles. As hormones, they regulate development and orchestrate the activities of our organs. As enzymes, they catalyze the chemistry taking place in cells. Yet it is the protein coats of viruses that latch onto our cells and allow diseases, from the common cold to HIV, to gain a foothold.

Seemingly infinite in variety, each protein is a string of just 20 amino acids, the sequence of which is dictated by the gene that directs its synthesis. Solving the mystery of how this string of amino acids folds and contorts to form protein is a major objective of structural biology. The APS can provide important information on the atomic structure and

mechanisms governing the biological functions of proteins, information that will help scientists understand and control protein behavior.

Viruses are nature's microscopic masters of disguise. They can perform rapid and substantial

changes to the amino acids that form their outer surface, changing the way they "look" to virus-hunting antibodies. The infectious capabilities of viruses are buried in clefts or "canyons" within the coats, inaccessible to the hunters sent out by the body's immune system. With knowledge of a hidden active site, researchers can identify pharmaceuticals that enter the canyon and attach themselves to the active site, inhibiting the ability of the virus to disgorge its contents into a host cell.

With enough structural information about the protein coating of a virus or bacterium, it should be possible to design and synthesize a small molecule to inactivate practically any infectious pathogen by binding to it in a way that inhibits its function. This approach is the basis of the "rational drug design" concept rooted in structural biology. To establish the detailed structure, the distribution of charge, and the arrangement of solvent molecules around an active site, x-ray crystallography and x-ray spectroscopy are essential. Progress in these areas holds out hope for designing pharmaceuticals that will, for instance, clog the influenza virus's active sites or contribute to an effective AIDS treatment.

Enzymes are the chemical catalysts of the living world. These proteins are essential for replication, synthesis, digestion, and decay. They can increase the rate of a biochemical reaction by factors of a

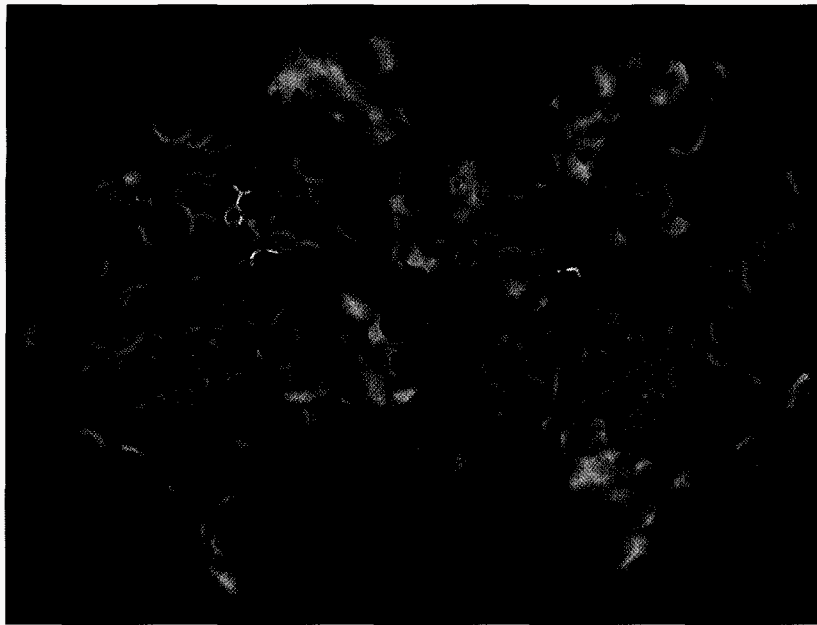

A cutaway view of the prostaglandin H synthase dimer show: the right monomer is in the active state while the left monomer has been inhibited by aspirin. (Courtesy Michael Garavito/The University of Chicago)

billion or more. The key to their speed and specificity is their three-dimensional structure. Examples of important roles for enzymes are bioremediation (cleanup of major oil spills and contaminated industrial sites) and enzymatic catalysts for production of new materials for everything from clothing and skin

grafts to adhesives and spacecraft. The potential for this aspect of biotechnology is nearly endless.

Another role for the APS in the biological sciences involves x-ray microscopy and microtomography for direct imaging of subcellular structures. The visible-light microscopes that have dominated the study of the microscopic world for centuries are limited to a resolution of about one micrometer, which is not fine enough to image most cellular components. X-rays can overcome this resolution limit, but optical elements to focus the x-rays have not been available. The use of recently developed Fresnel zone plates, used with APS x-ray beams, make it possible to focus x-rays to spots as small as a few hundredths of a micrometer. X-ray microimaging offers several advantages to scientists. First, the penetrating property of x-ray beams permits the viewing of unsectioned objects suspended in a solution similar to their natural environment. In addition, high-resolution x-ray "snapshots" of biological systems, obtained with exposure times of less than a millisecond, may soon become feasible, offering the opportunity to probe dynamic subcellular events. Finally, x-rays offer the potential for elemental mapping — that is, establishing the distribution of specific chemical elements within a biological specimen. ●

Once thought infinite and virtually indestructible, our natural environment is now recognized as finite and, in many ways, even fragile. The technological advances we have achieved in the last century have created a clear need for greater understanding and management of our environment, and new tools with which to achieve these goals.

Revolutionary x-ray techniques available at the APS for diffraction, scattering, spectroscopy, and imaging promise significant gains in overcoming some of the special challenges of the earth and environmental sciences. These include the opacity of soil and other environmental samples; the lack of information about how contaminants are physically, chemically, or biologically bound in the environment, and how they transform and migrate; the low levels of pollutants available for study at any point in the sample; the role of interfaces in the movement of pollutants; real-time investigations of environmental phenomena; and structure, bonding, and composition of materials under conditions of extreme temperature and pressure. Ultimately, the collective work of environmental scientists, geochemists, geophysicists, mineralogists, soil scientists,

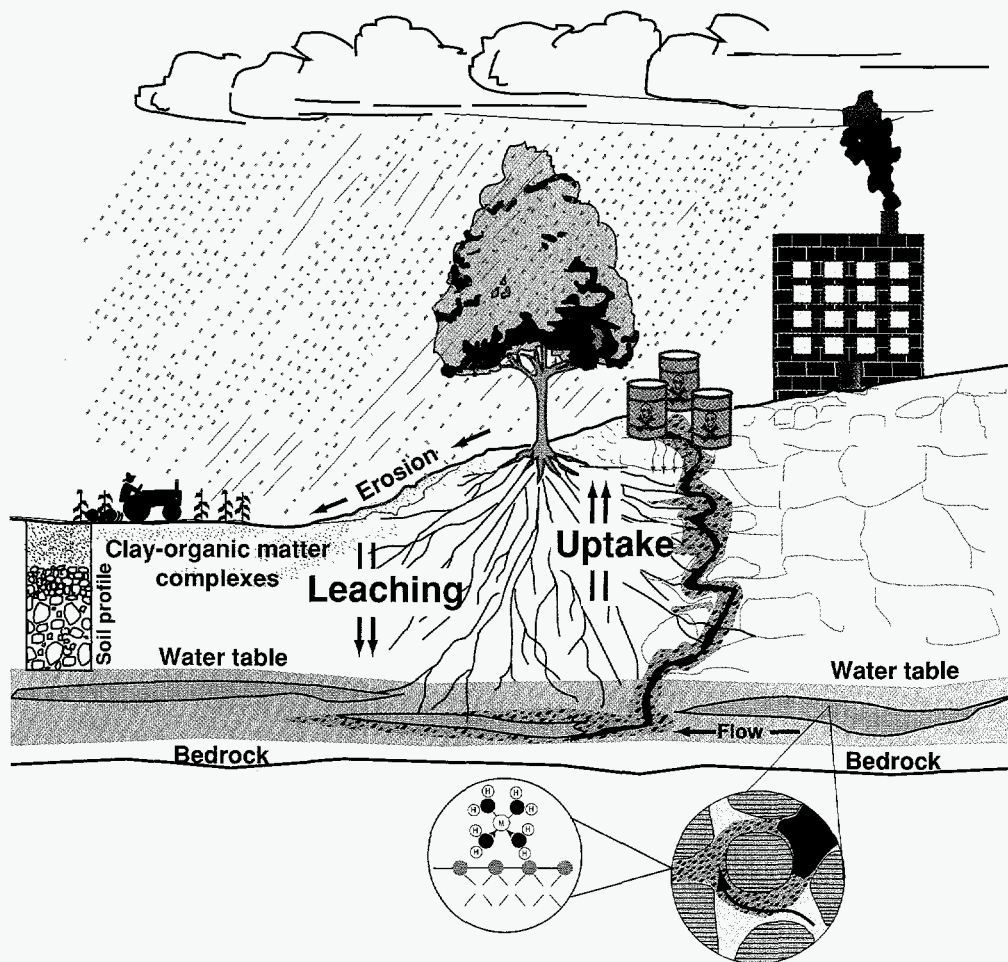

Movement of toxic materials in the environment can be influenced by weather, vegetation, subsurface processes, and many other mechanisms. The exploded view indicates that the transport and fate of toxins in the environment will often depend on the detailed structure of interfaces. In this case, the fate of a dissolved toxin in a subsurface aquifer depends on the way hydrated metal ions (red) are bound to the surface of soil particles (orange).

agricultural scientists, physicists, chemists, and biologists will be needed to address these complex real-world issues.

For decades, the world just under the Earth's surface has been the recipient of many toxic elements, such as arsenic from pesticides and defoliants, and toxic metal contamination from mines and industrial sites. The soil in many of our largest cities still contains hazardous levels of lead, even though the use of lead-containing fuels and paints has been

sharply reduced. Added to this contamination is the enormous quantity of mixed radioactive and toxic wastes from the nuclear weapons programs of several countries. These corruptions pose a long-term threat to our soil, our water supply, and the public health. Research has shown that the chemical form of contaminant metals, not the total amount present, determines their toxicity, behavior, and mobility in the environment. While detailed information on the chemical forms of toxic elements is crucial to a complete understanding of this problem, current research methods lack the sensitivity required for study of the relatively small amounts of toxic materials present in a typical sample. The synchrotron-based research techniques used at the APS can be 10 to 1000 times more sensitive than traditional research methods and may lead to a new level of insight into contamination of the subsurface world. A greater understanding of this complex world is essential to reducing environmental cleanup costs, which are currently more than \$1 trillion a year in the U.S. alone.

Abundant crops depend on an adequate supply of plant nutrients. But

when nutrients are present in excess, they may retard plant growth and degrade surface- and ground-water quality. Even though a nutrient is present in the proper amount, it may not be available for plant uptake because of interactions with soil mineral surfaces. Soil testing is a standard practice for determining how much of any plant nutrient is present. In some cases, soil test results do not accurately predict plant response to fertilization, forcing crop producers to make decisions based on unreliable data.

Experiments with synchrotron x-ray beams can give agricultural scientists the information they need. There is increasing evidence that the oxidation state of iron in soil clay minerals plays a key role in determining the availability of potassium.

Scientists suspect that reduction of iron in the structure of the clay minerals causes them to collapse, trapping potassium between layers. The extremely high intensity and selectable energy range of APS x-ray beams allow scientists to determine the effects of iron oxidation on the distribution of layer spacings in soil clay minerals, and test the validity of this theory.

Earth and planetary scientists study geological systems looking for clues to our planet's evolution and its present and future state. They examine the many chemical and physical factors that control

processes or properties such as the formation and drift of continents and ocean basins; heat flow in the Earth; shaping of the Earth's land forms; earthquakes, volcanic eruptions, and other natural disasters; the stability of minerals over enormous ranges of temperature, pressure, and time; and the composition of natural waters and the atmosphere. All of these processes and properties, no matter how vast or tiny in magnitude, are ultimately controlled by small-scale forces and atomic-level structures, reactions, and

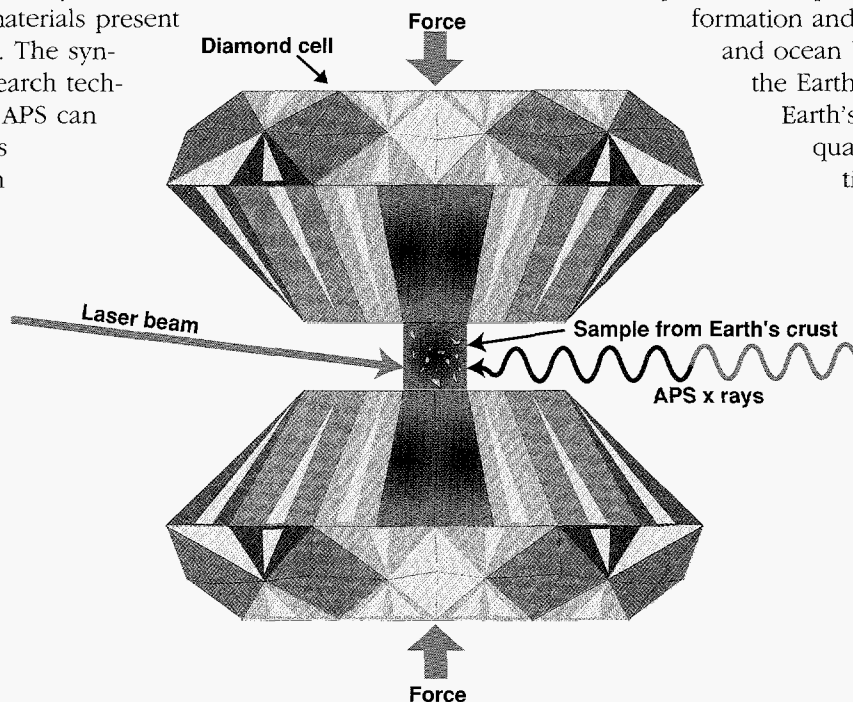

The diamond anvil cell provides ultra-high pressure and a laser beam provides ultra-high temperature (about 7000° F) to simulate geochemical forces and temperatures. Combined with APS x-ray beams, such instruments can probe reactions that could have formed the earth's crust and mantle.

transformations. Often, these processes occur only at extremely high temperatures and pressures, such as those that exist in the molten interior of the Earth. X-ray research at the APS is ideally suited to answering many of the key questions in this field, using existing techniques as well as new classes of experiments that are not possible with previous x-ray and synchrotron radiation sources. For instance, to understand the geochemical mechanisms of the Earth's origin, and the enormous forces involved in the formation of its crust, it is important to simulate the high pressures and temperatures of geochemical activity. At the APS, high-brilliance x-ray beams can be combined with a high-pressure diamond cell to provide geological-scale pressures and temperatures (see figure above). ●

The possibilities arising from chemical reactions have for centuries been the stuff of fascination. The alchemists of medieval times, in their efforts to convert lead to gold, were closer to a great scientific truth than even they knew. Chemical reactions take place when two reactants come together and their atoms rearrange to form new products. Only in the last few years have modern tools, like synchrotron radiation and lasers, made it possible to directly measure the positions and movement of atoms during chemical changes. Studies at this most basic level hold the promise of new chemical products, more efficient chemical catalysts, and even novel ideas for controlling chemical processes. Chemists and chemical engineers using the APS have the means to observe atomic arrangements in minute chemical samples and to follow chemical processes occurring in less than a billionth of a second.

The pulsed nature of an APS x-ray beam is ideal for the study of photosynthesis. This process has been avidly studied since the 18th century, when Joseph Priestley discovered that plants exposed to sunlight produce a life-supporting combustible gas that was later named oxygen. Over the millennia, photosynthesis has continually converted the enormous energy content of sunlight into useful energy sources, such as coal, petroleum, natural gas, wood, and food. To better understand the basic mechanism of photosynthesis, chemists working at the APS employ a "pump-probe" experiment in which a laser pulse is used to excite the first step in the photosynthetic reaction, and then an x-ray pulse from the APS is used to probe the reaction at various intervals after the laser pulse. In this way, key information about the time evolution of interatomic bonds during photosynthesis can be obtained. This work may lead to the design of artificial photosyn-

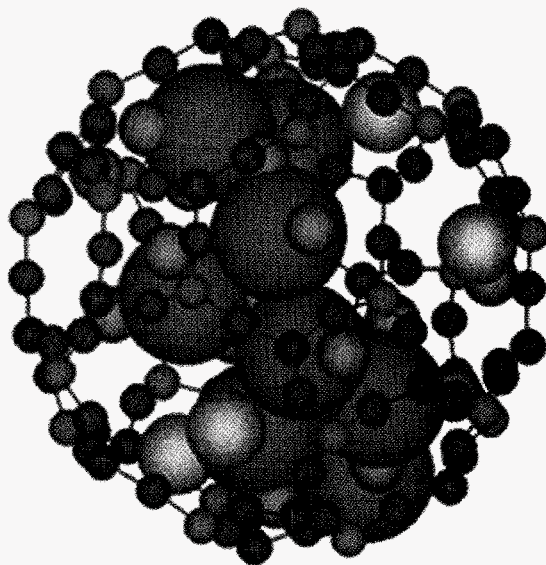

Many important chemical processes use the microporous structure of zeolites to catalyze chemical reactions and to store reactive or toxic molecules at high density. Since zeolites are often only available in micron-sized crystals, the high-brilliance x-ray beams of the APS are needed to determine their structure and how they work. Shown above is a simulation of a cluster of $\text{Li}_{15}\text{K}_5\text{Cl}_8$ (large purple spheres), trapped inside a cavity of Zeolite-A (small multicolored spheres). (Molecular dynamics simulation courtesy of Frans Trouw, Intense Pulsed Neutron Source, Argonne.)

thetic systems and molecule-sized photon switches.

Perhaps the most exciting feature of the APS is the brilliance of the x-ray source. The APS, for the first time, can reveal high-resolution structural information on samples smaller than a one-micron cube, about 100 times smaller than samples that have been studied with earlier synchrotron x-ray sources. Many of the materials vital to modern technology are available only in very small samples. Among these are the zeolites and other important catalysts used in the petroleum and chemical industries. The APS makes it possible to obtain atomic-level structural information on new catalysts that only exist in microcrystalline form. This information will reveal the workings of catalytic materials and how they can be tailored for new applications. The pulsed, penetrating x-ray beam from the APS can be used to perform real-time studies of

catalysts under actual operating conditions, providing insight into the way microscopic changes can affect their performance. Because some 20 percent of America's gross national product comes from products that involve catalysis, development of new catalysts is clearly vital to U.S. economic competitiveness.

Another new application at the APS is the determination of atomic arrangements at liquid-solid and solid-solid interfaces. Many important chemical processes occur at interfaces, including electrochemistry and corrosion. A brilliant x-ray source is needed to study these interfaces for two reasons. First, x-rays can penetrate either liquid or solid layers to reach the interface. And the brilliance makes it possible to focus the beam to a thin ribbon that matches the geometry of the interface, a match that is necessary to create a useful probe. The APS opens a new window onto hidden interfaces, leading to basic ideas and applications in such areas as advanced battery and coating technologies. ●

Liberated K-shell electron

Atoms and molecules are the building blocks of the physical world. The intense, high-energy x-ray beams produced by the APS give researchers a new tool for selectively probing even the innermost electron shells of any atom in the periodic table. This capability provides not only a means to detect and manipulate atoms and molecules, but also to explore novel physics that can be examined only under conditions available at the APS.

X-rays interact most strongly with electrons deep inside the atom near the nucleus (see figure).

Because the interior of an atom is protected from the external environment by the atom's outer electronic shells, characteristic features in the spectra of atoms excited by x-rays will very often remain unchanged when the atom is placed on a surface or when it becomes a constituent of a molecule. This property of x-ray spectra has been invaluable in understanding a variety of basic and applied phenomena. For example, atomic fluorescence detected by x-ray microprobes is used to determine the presence and spatial distribution of atoms in a broad range of materials in order to understand their chemical and physical properties.

Atomic, molecular, and optical physicists are anxious to capitalize on the opportunities in basic research made possible by the APS. In atomic physics, intense, high-energy x-ray beams can be used to study new types of atomic processes. Researchers can now create exotic types of atomic ions by removing all the electrons in an inner shell near the nucleus, and then studying the behavior of the resulting "hollow" ion. By stripping electrons from atoms and storing the resulting energy-packed, unstable ions in an ion trap (a device that

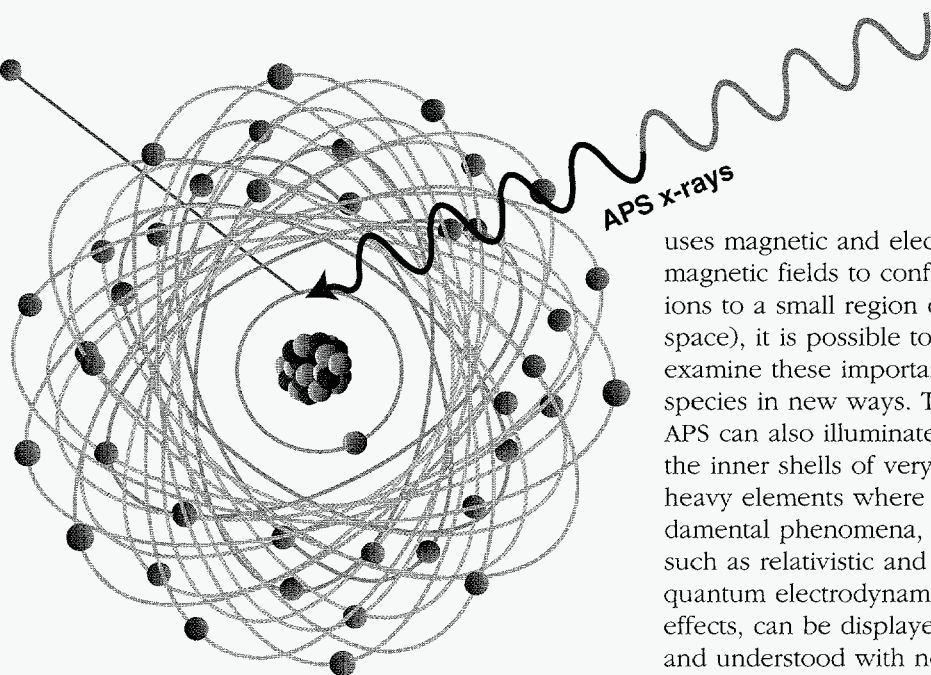

X-rays from the APS can penetrate deep inside atoms and knock loose electrons nearest the nucleus. Shown here is the ejection of an electron from the innermost shell of the molybdenum atom. The ability to probe deep inside heavy atoms and attain new levels of instantaneous x-ray powers will make possible new types of investigations in atomic physics.

uses magnetic and electromagnetic fields to confine ions to a small region of space), it is possible to examine these important species in new ways. The APS can also illuminate the inner shells of very heavy elements where fundamental phenomena, such as relativistic and quantum electrodynamic effects, can be displayed and understood with new clarity.

In molecular physics, x-rays can be used to remove electrons from inner shells of selected atoms in a molecule to learn if the subsequent rapid dissociation of the molecule can be manipulated by such selective

excitation. Both x-ray spectra and x-ray scattering can be used to trace the evolution of physical properties from atoms through small atomic clusters to solids. Hence, the APS will be extremely useful in addressing the intellectual connection between atomic, molecular, and condensed matter physics.

In optical physics, the intense, coherent x-ray beam from the APS can be crossed with a laser beam to explore the simultaneous effects these two modern light sources have on atoms. Since the x-ray beam interacts primarily with the atomic inner shells, while the laser beam interacts primarily with the atomic outer shells, it is possible to envision an exciting new type of experiment – one in which the behavior of an atom is observed while it is simultaneously being probed in two very different regions of space by intense light beams.

These basic studies are expected to produce a fundamental new understanding of the ubiquitous atom and its role in applications involving more complex materials, and to provide knowledge useful for developing such technologies as the x-ray laser and fusion energy.

The United States can confidently claim to have the best medical diagnosis and treatment capabilities in the world. But we are still far from reaching our potential. Synchrotron x-ray research can be a significant factor in advancing medical science. The brilliance and tunability of APS x-ray beams can dramatically improve the speed, clarity, and safety of diagnostic tools, such as coronary angiography and computed axial tomography scans. New ideas for medical imaging and therapy using x-rays are emerging, while miniaturization of medical devices and improvements in materials will produce significant gains in the development of new prosthetics and invasive techniques.

Cardiovascular disease is the greatest single health problem in the U.S. Each year, heart attacks kill as many as 600,000 people, half of whom had no idea they were in danger. Yet, medical science knows little about the disease process, and current methods for performing coronary angiography, or artery evaluation, are both risky and expensive. We know that narrowing of the arteries, which are normally about 1 mm thick, leads to heart attacks. And we can image heart arteries by filling them with compounds containing x-ray-absorbing iodine and photographing the patient with x-rays. Normally this x-ray "dye" is injected directly into each coronary artery by means of a catheter passed through the patient's major arteries. Most of the risk associated with coronary angiography comes from this invasive catheterization and from the large quantities of iodine needed for the photographs.

Synchrotron radiation from the APS provides a safe way to perform angiography by avoiding the catheterization and reducing the required amount of dye. Two x-ray beams, one tuned to an energy readily absorbed by the iodine and one at a slightly lower energy, are used to record two images simultaneously. When a computer subtracts one image from the other, the view of the arteries is enhanced 150,000 times over that of bone or flesh. This extreme sensitivity allows the use of much lower iodine concentrations and lower x-ray doses, compared to conventional angiography. With such low

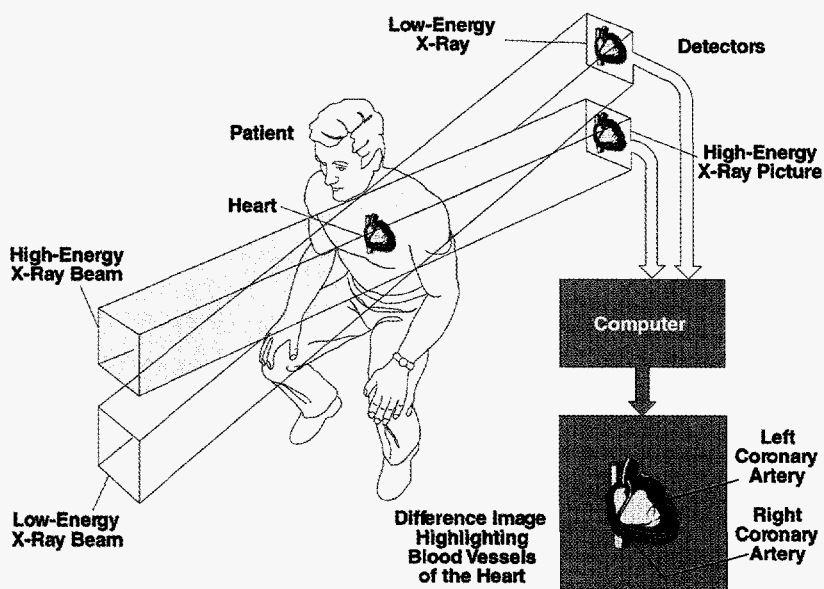

To perform angiography with APS synchrotron radiation, an x-ray beam is precisely tuned to the energy iodine absorbs most easily. Two images are taken together — one at that energy and one at a slightly lower energy. When a computer subtracts one image from the other, the image of the arteries is enhanced 150,000 times over that of bone or flesh.

iodine levels, the dye can be safely introduced through an arm vein. And by using the extreme brilliance of APS x-ray beams, an image can be formed in milliseconds, fast enough to make "snap shots" and "movies" of the living, beating heart and nearby arteries.

New ideas for medical imaging do not stop with angiography. Magnetic resonance imaging is a powerful diagnostic tool. But MRI gathers information by sensing water molecules in body tissue. When the concentration of water is low, as it is inside the lungs, MRI is of limited value. One proposed work-around is to have a patient inhale a harmless, inert gas like xenon. The xenon can then be imaged using x-rays in order to diagnose problems that arise in air spaces in the lungs, such as lung cancer.

Among the new types of radiation therapy that can use the tight focus and tunability of APS x-ray beams is tomotherapy. Radiation is focused into a particular volume of tissue by shaping the x-ray beam using slits or optics, and rotating the x-ray source relative to the patient. Tomotherapy concentrates the radiation in a defined, three-dimensional area within the body while minimizing the collateral damage to surrounding tissue. If a chemical is concentrated in the tumor, the effectiveness of the therapy can be further increased by tuning the x-rays to excite only that chemical. ●

New manufacturing ideas have dramatically altered civilizations in the past and will certainly determine the winners in future global economic competitions. For example, miniaturization of electronic circuits has profoundly affected our lives through the development of computers and computer automation. The APS makes possible a new vision — an x-ray micromanufacturing plant in which we can go beyond the two-dimensional microchip to the mass production of miniature three-dimensional (3D) devices barely visible to the naked eye.

Potential applications of micromanufacturing include micromotors, microsensors, microswitches, microplumbing, and micro-optics for the medical, robotics, and sensor industries. Microminiaturization of these components brings advantages such as compactness, faster or more accurate response, lower cost, and a higher level of integration into miniaturized systems. Micromanufacturing also provides a natural interface between digital microelectronics and the external world. The market for micromanufactured machines and parts is nearly \$1 billion annually and is showing rapid growth. The APS could significantly accelerate this emerging field and contribute to the development of new products and markets.

Most current micromachining techniques are based on the silicon processing techniques developed for fabrication of integrated circuits. This approach has drawbacks for micromanufacturing, including the less-than-desirable mechanical properties of silicon and modest thickness-to-width ratios, typically less than 20 percent. The ability to fabricate structures with aspect ratios greater than 100 percent is essential in many micromanufacturing applications. A new technique called deep-etch x-ray lithography can produce microscopic structures in a broad range of materials to satisfy the ultimate goals of micromanufacturing.

Although very similar to the "soft" x-ray lithography used for fabricating integrated circuits, deep-etch lithography with the "hard" (highly penetrating) x-rays available from the APS presents several important advantages. The shorter wavelength of hard x-rays means less diffraction, so that smaller features can be printed onto thicker photoresist

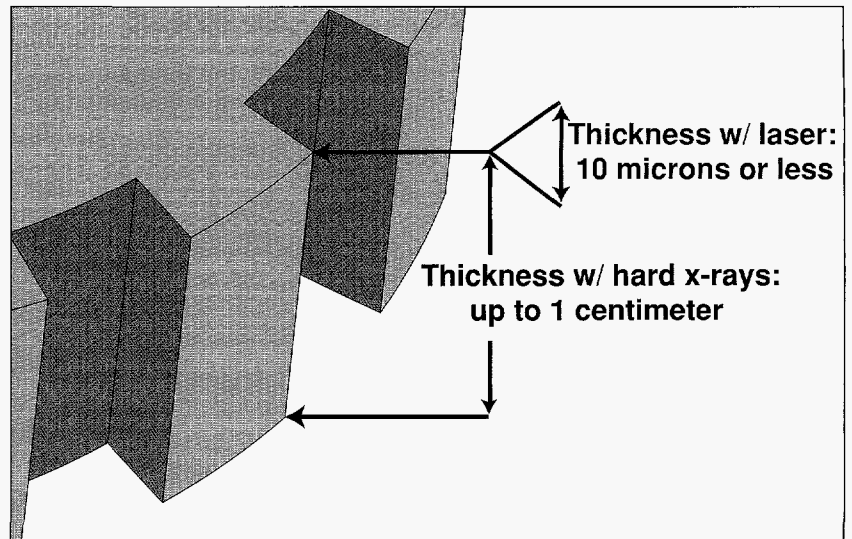

High-brilliance x-ray beams can convert the thin-layer lithography used to make computer chips into "deep-etch" lithography that can make three-dimensional parts (gears, sensors, tools) with enough strength to be used in new applications. This form of micromanufacturing can make high-precision parts with dimensions from microns to centimeters.

material. The mask that defines the shape of the manufactured product can be more rugged. The higher energy photons are also more penetrating and can produce a uniform dose throughout the photoresist, thereby eliminating over-exposure. The APS produces the hard x-rays needed for deep-etch x-ray lithography, as well as high-energy x-rays for penetration and fast processing time, and parallel beams for high resolution.

Three-dimensional (3D) automated precision machining is another promising micromanufacturing technique. At present, lasers are the tool of choice for this application. But lasers have several drawbacks, such as limited penetration. High-brilliance x-ray beams offer superior beam shaping, control, precision, penetration, and power densities, and will be a much more versatile tool for 3D micromanufacturing. Integrated 3D molding, machining, drilling, welding, and surface finishing are all possible in one location in the APS experiment hall.

Stereolithography is used to make prototypes by transforming a liquid polymer into a solid polymer. This process, called photopolymerization, exposes the polymer to an ultraviolet light laser source. The high thermal expansion rate of polymers limits prototype sizes and causes cracks and breakage. X-ray stereolithography can dispense with these limitations, leading to significant improvements in this rapidly growing micromanufacturing industry. ●

SYNCHROTRON RADIATION & INSERTION DEVICES

Synchrotron radiation is a perfect resource for our times. It has existed since the Big Bang; it is in the starlight that we see at night, created by charged particles of matter spiraling through the cosmos for millions of years at light speed. More than 100 years ago, theorists began puzzling out the natural mechanism that creates synchrotron radiation. But a manmade, controllable source of this invaluable radiation wasn't found until the middle of the twentieth century, when high technology began to change everything. Now synchrotron radiation produced by our most advanced technology gives us access to an invisible light that is ideal for solving the submicroscopic riddles of our high-tech world.

Synchrotron radiation

has proven to be a powerful, versatile source of x-rays for probing the structure of matter and studying various physical, chemical, and biological processes.

The wavelengths of light in synchrotron radiation cover a broad segment of the spectrum, extending beyond deep-violet, invisible to the human eye. These wavelengths, which include ultraviolet and x radiation, are small relative to the visible part of the spectrum. Their wavelengths match the corresponding features of atoms, molecules, crystals, and cells, just as the wavelengths of larger visible light waves in the middle of the spectrum match the sizes of the smallest things we can observe with our eyes. With a bright, penetrating light like x-rays from synchrotron radiation, scientific instruments can "see" deep into the atomic structure of matter. Depending on the type of experiment being carried out, the energy of photons from synchrotron radiation can be minutely adjusted, or tuned, to the wavelength that is most useful.

Theoretical predictions of electromagnetic radiation began with Maxwell's Equations in 1873. In 1898 (one year after the electron was mathematically discovered, and three years after Röntgen's discovery of the x-ray), Liénard stated that energy must radiate from an electric charge following a

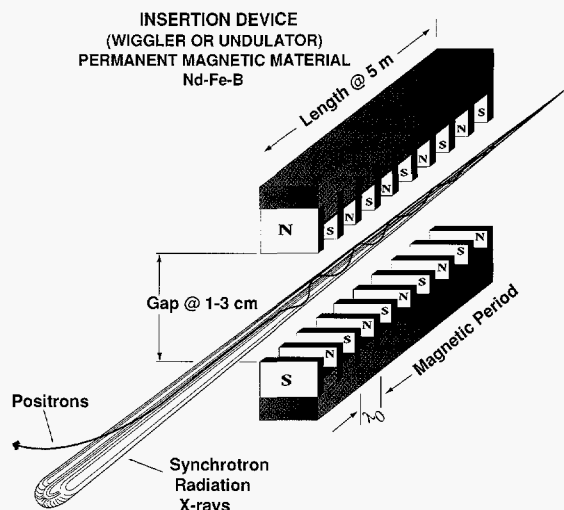

Shown above is the cone of x-rays generated by positrons moving with near-speed-of-light energy through an insertion device. The array of permanent magnets produces a magnetic field that alternates up and down along the positron path, causing the particles to bend back and forth along the horizontal plane. At each bend, the positrons emit synchrotron radiation in the x-ray part of the spectrum.

curved trajectory — under the influence of a magnetic field, for example. He also calculated the rate at which this radiation would drain energy from an orbiting electron. Nine years later, Schott, in search of an electron theory of matter, solidified Liénard's concepts. There matters stood for over 40 years, waiting for technology to catch up.

Machines to accelerate subatomic particles for research first appeared in 1940. By the mid-'40s, scientists at the General Electric Research Laboratory at Schenectady, New York, were building a 70-MeV bending magnet-based synchrotron to test McMillan's and Lawrence's theories on accelerating electrons with synchronized pulses of radio frequency (rf) voltage. In 1947, the syn-

chrotron team observed what team leader Pollock described as "a very bright spot of light coming from the [vacuum] tube on the left hand side. This light only appeared when the rf was running and the timing of the gun was right." This was the first sighting of synchrotron radiation, which the GE scientists immediately put to work as an aid to machine operations.

The energies of accelerators increased as they were used to hurl charged particles at targets or, much later, at other charged particles in search of the fundamental constituents of matter. High-energy physicists regarded synchrotron radiation as a costly annoyance, because energy given up by orbiting particles, as predicted by Liénard, had to be replaced or else the beam would slow down.

In 1956, Tomboulia and Hartman of Cornell University published results from the first experiments with far-ultraviolet light and soft x-rays from synchrotron radiation. Two years later, Parratt, also from Cornell, suggested that using synchrotron radiation to produce hard x-rays "would be a boon in many aspects of x-ray physics." He noted that because "orbit radiation is a waste product ... use of this radiation in x-ray physics would ... be essentially free." More and more researchers began using the "free" radiation from the high-energy

machines. By the mid-1970s, a new generation of particle-beam storage rings entirely dedicated to the production of synchrotron light from bending magnets were being funded and constructed worldwide. The era of free synchrotron radiation was over, but a more exciting time was about to begin.

At the beginning of the 1980s, Vinokurov, at the Budka Institute of Nuclear Physics in Novosibirsk, and Halbach, at Lawrence Berkeley Laboratory, working independently of each other had developed insertion devices (IDs) that utilized iron poles combined with permanent magnets to generate high magnetic fields and more coherent synchrotron beams. These new devices immediately raised the stakes for light-source technology. The need for particle-beam storage rings designed specifically to operate with IDs quickly became evident.

A storage ring is actually a set of curves connected by straight sections. Linear arrays of north-south permanent magnets with alternating polarity are inserted (hence the name insertion device) into the straight sections, one array above the beam path, the other below. When charged particles in a storage ring pass through the alternating fields, they either wiggle or undulate, depending on the configuration of the ID. This action greatly enhances the synchrotron radiation. In wiggler IDs, a high magnetic field and a relatively greater distance (or period) between the individual magnets produces very intense radiation over a wide spectrum. The magnets in undulator IDs have a lower field than those in wigglers, and they are spaced closer together. The lower magnetic field in undulators narrows the cone of radiation emission, allowing all the radiation from each pole to interfere constructively. This interference creates peak intensities at certain energies and high-brilliance beams that are tunable to the wavelength that each experimenter desires.

Storage rings optimized for IDs are "third-generation" light sources. Some, like the Advanced Light Source, in California, and the SuperACO, in France, provide radiation in the ultraviolet/soft x-ray part of the spectrum. The 7-GeV APS and its sister facilities, the 6-GeV European Synchrotron Radiation Facility (ESRF) now operating in France and the Super Photon Ring 8-GeV (SPring-8) under construction in Japan, can produce a range of x-rays up to those of the hard (highly penetrating) variety because of higher machine energies.

Third-generation storage rings maximize those x-ray beam qualities, flux and brilliance, that are needed for frontier experimentation. Flux and brilliance are benchmarks of x-ray beam quality. Both are based on a measure of the number of photons per second in a narrow energy bandwidth and in a unit of solid angle in the horizontal and vertical directions. Flux is the number of photons per second passing through a defined area, and is the

appropriate measure for experiments that use the entire, unfocused x-ray beam. Brilliance is a measure of the intensity and directionality of an x-ray beam. It determines the smallest spot onto which an x-ray beam can be focused.

Design and fabrication of IDs for the APS has been a long-term, cooperative R&D effort between the APS, other synchrotron facilities, and private industry. In the initial phase of APS operations, APS Undulator A and APS Wiggler A have evolved as the IDs of choice for most CATs. Undulator A is very close to achieving the ultimate x-ray beam brilliance for devices of its kind. Undulator A is capable of delivering high-brilliance beams in the hard x-ray region from 4.2 keV to better than 40 keV. Wiggler A produces a broad continuum of

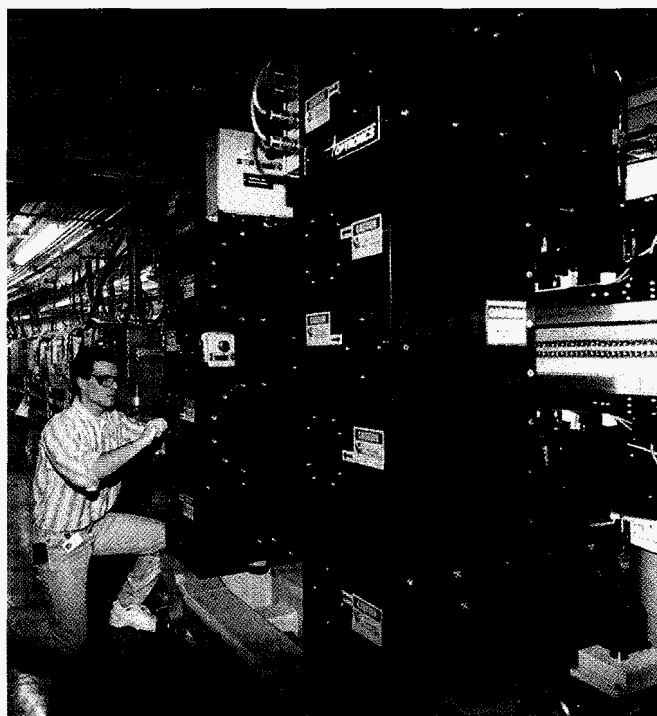

An APS Undulator A installed in the storage ring. Undulator A is tunable, capable of delivering high-brilliance beams in the hard x-ray regime from 4.2 keV to better than 40 keV.

radiation up to 100 keV. Bending magnet radiation sources at the APS also have unique capabilities because of their high brilliance, particularly above 20 keV.

Another essential element of the APS design is flexibility. Different types of IDs operated simultaneously at different locations in the machine can tailor the radiation source for a particular experiment. While an undulator installed on one APS beamline is delivering 10-keV hard x-ray beams, a wiggler installed at another beamline can produce circularly polarized x-ray beams, all without disrupting storage ring performance. ●

TECHNICAL SYSTEMS

The mission of the Advanced Photon Source is to produce insertion-device- and bending-magnet-based synchrotron radiation for use in forefront research in science and technology. Synchrotron radiation is produced by the precision, controlled motion of a high-energy particle beam generated by APS accelerator systems.

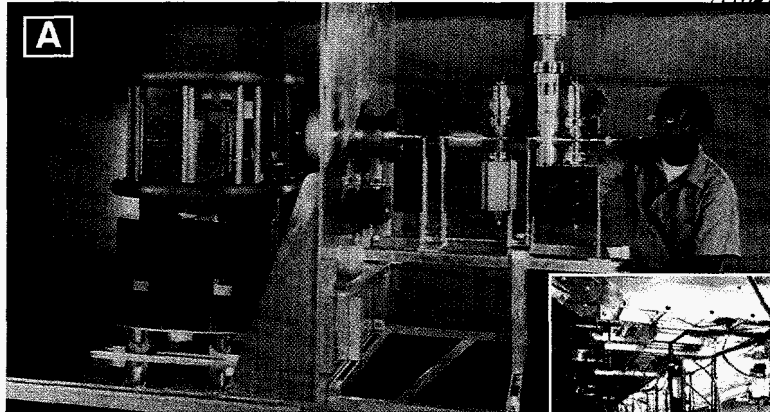

The beam acceleration and storage process begins with an electron gun [A], a cathode-ray tube much like one in a television. An electrical charge of 750,000 volts produces electrons, which accelerate through an electron linear accelerator (or linac) [B] where the energy of the electrons is raised to 200 million electron volts (MeV) by waveguides. Next, the electrons strike a 7-mm-thick, water-cooled tungsten disk, the positron conversion target.

This interaction creates electron-positron pairs. Positrons with an energy of 8 MeV are accelerated to 450 MeV in the positron linac [C], which is essentially a duplicate of the electron linac.

Twenty-four pulses of positrons are collected in a half-second by the positron accumulator ring (PAR) [D], which is 31 m in circumference, 1/12th the size of the booster synchrotron. Major magnets in the PAR are arranged in mirror symmetry along north-south and east-west center lines. When a sufficient number of positrons are captured, they are injected into ...

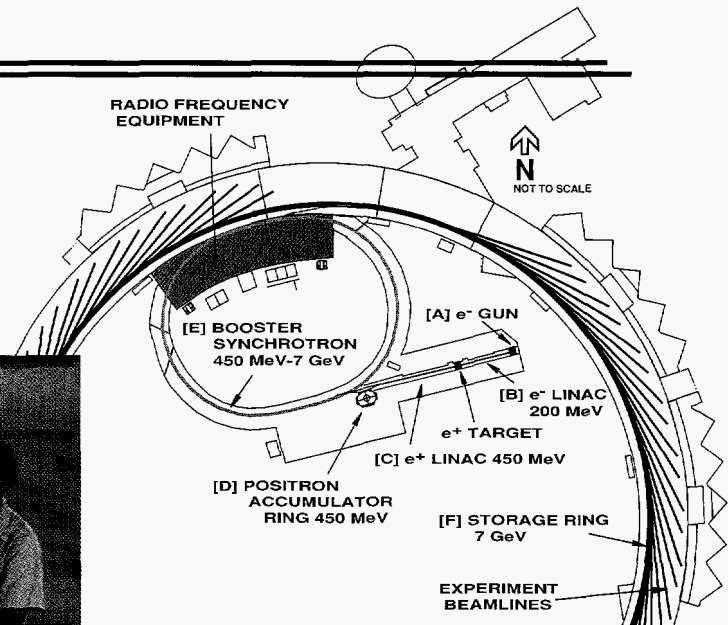
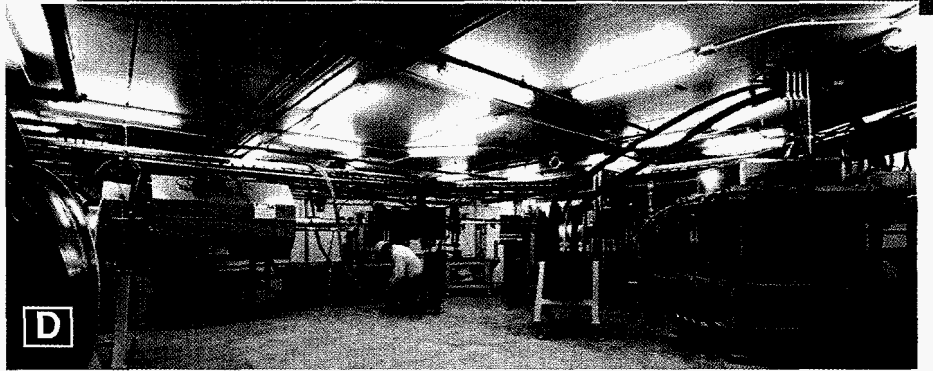
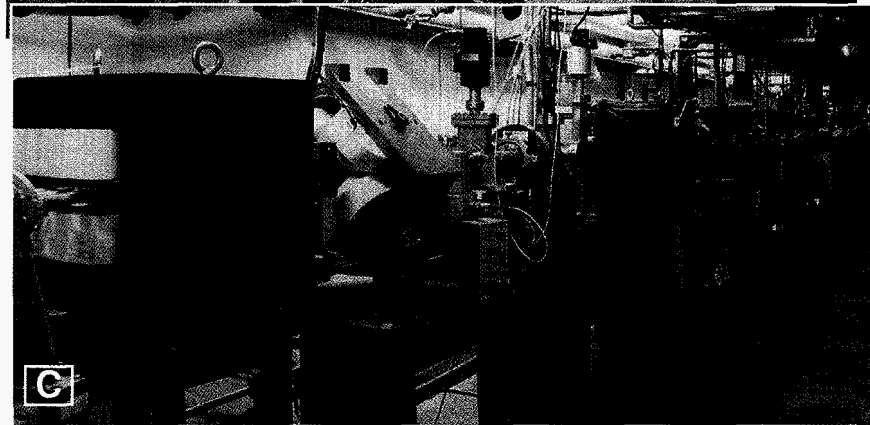
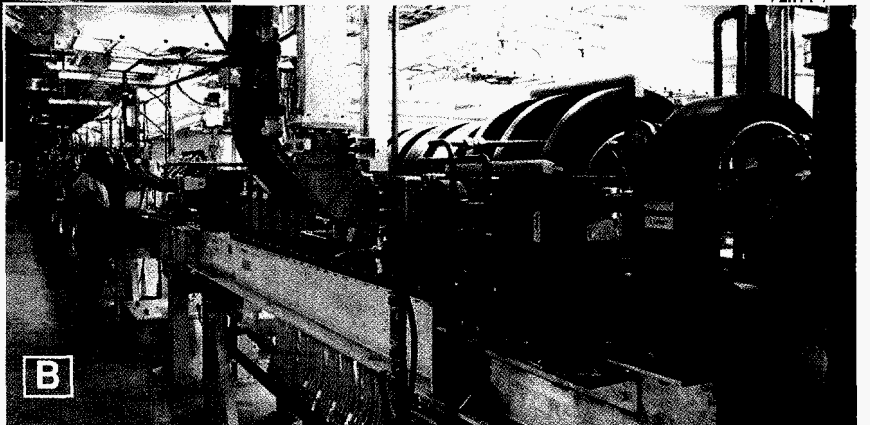

... the 368-m long, racetrack-shaped booster synchrotron [E]. The booster synchrotron raises positron energies at a rate of 32 keV per turn. The accelerating force is supplied by electrical fields within four 5-cell rf cavities operating at 352 MHz, the same frequency used by the storage ring rf cavities. In 1/4 sec, positrons orbit through the booster 200,000 times as their energy climbs to 7 billion electron volts (GeV) — approximately the speed of light.

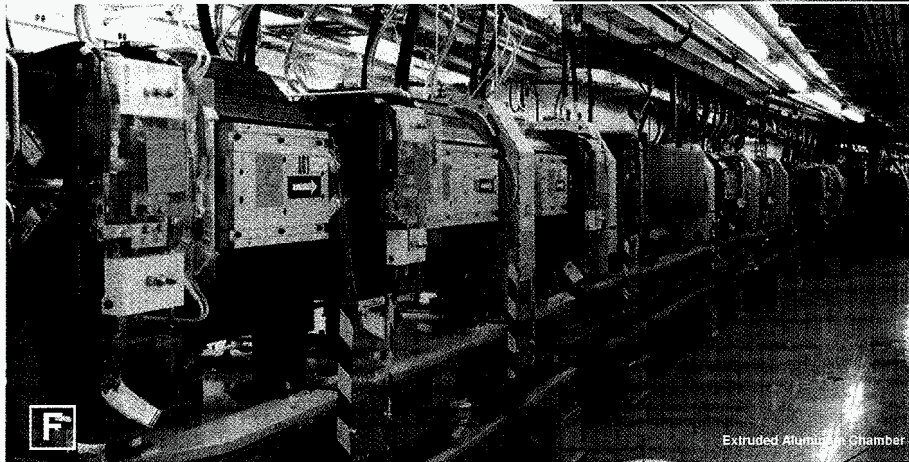
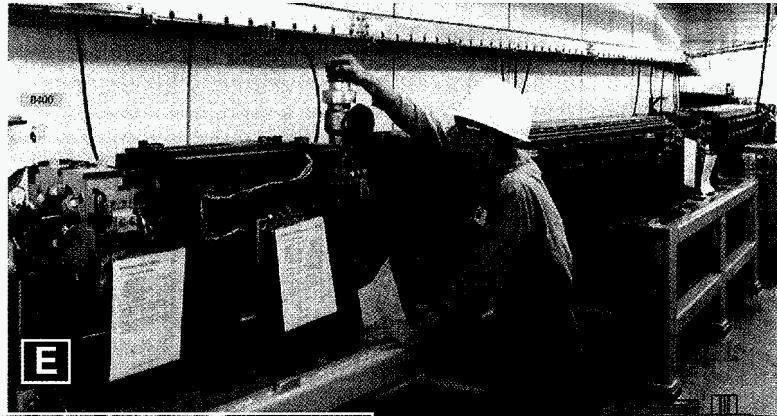

→ *Corrector magnets, such as this one for the booster synchrotron, steer the positron beam to compensate for magnet misalignment, ground settlement, or nanometer-level vibrations from other magnets.*

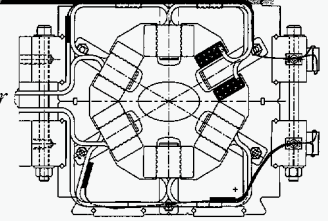

Positrons are injected into the 1104-m circumference storage ring [F], located inside the experiment hall, and orbit the ring more than 271,000 times per second. The beam is steered and focused by 1503 electromagnets. It must be protected from collision with gas molecules within a closed tube of 240 aluminum alloy vacuum chambers (shown in cross section, above right) running through the magnet centers. The beam decelerates at a rate of 6.8 MeV per turn as it emits synchrotron radiation. This loss is replaced by the 352-MHz rf systems in the storage ring. Every 10-20 hours, the booster supplies additional positrons to replace those lost after a collision with a gas molecule or with other positrons.

A typical APS storage ring sector (1 of 40) is shown below. Five of the sectors are taken up with injection and rf equipment. The remaining 35 are equipped to provide ID and bending magnet radiation. The magnets are sequenced according to the Chasman-Green lattice designed specifically for light sources. It provides a particle beam optimized for production of high-brilliance radiation, and

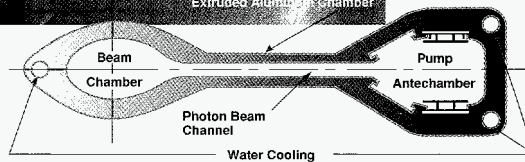

→ *Dipole magnets steer the positron beam on a closed orbital path in the accelerators. Half of the 80 storage ring dipoles, shown at right, provide radiation to experimenters via beamlines.*

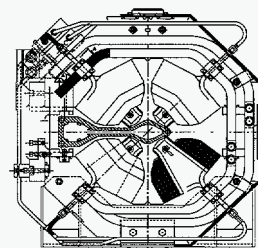
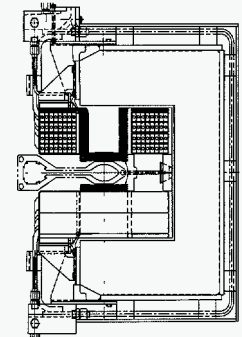

← *Three lengths of quadrupole magnets are used at different locations in the storage ring lattice. Eighty are .8 m, another 80 are .6 m, and 240 are .5 m. They focus (control the size of) the positron beam, just as light is focused by a lens.*

allows for straight sections where insertion devices can be placed. Magnets and vacuum chambers are mounted on girders, which are aligned in the storage ring tunnel to a tolerance of ± 0.1 mm.

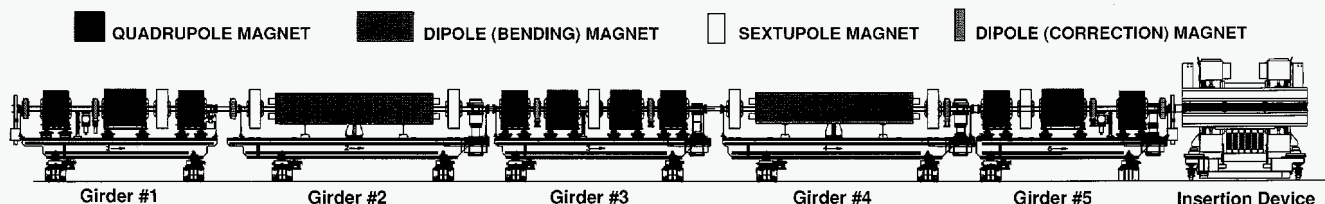

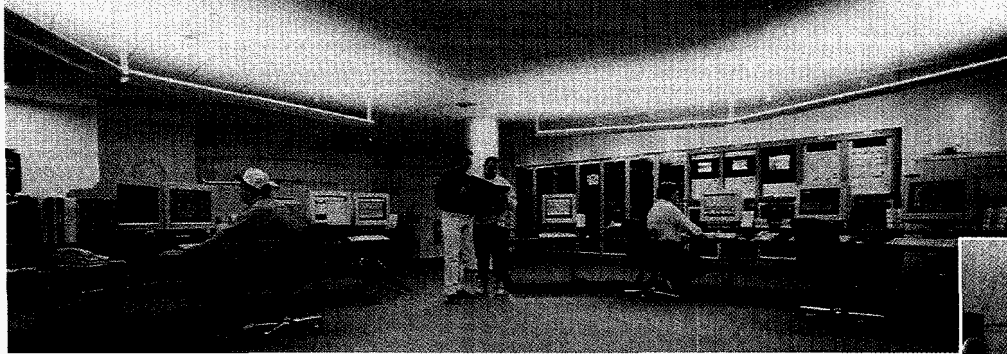

Left: The APS main control room. Below: Storage ring beam position monitor buttons mounted on a section of aluminum-alloy vacuum chamber for test.



The APS accelerators are run by teams of operators on duty around the clock in a main control room. Workstation-type computers are used to send commands, via a high-speed network, to more than 150 other computers called input/output controllers (IOCs). The IOCs control more than 80,000 variables, including voltages, power levels, timing controls, and the positions and functions of numerous other components.

Computer programs that manage communications between workstations and IOCs are based on a set of software called the Experimental Physics and Industrial Control System (EPICS). These graphic- and text-based electronic tools allow computer scientists to tailor-make data acquisition and control systems. EPICS also displays information on machine status, and replaces mechanical gauges and switches with functional graphic counterparts.

EPICS was first developed at Los Alamos National Laboratory (LANL). After APS scientists asked to tailor part of EPICS to their specific needs, the two groups teamed up to produce a flexible system suitable for use at facilities of varying types and sizes. EPICS can connect one workstation to a single controller with only a few hundred data channels, or run systems larger than the APS. It can require extensive adjustments by the operator, or be configured as a fully automated system.

The DOE, the University of California (operators of LANL), and The University of Chicago (operators of Argonne) share the EPICS copyright, allowing scientific research facilities to use EPICS free of charge. These include the Advanced Light Source at Lawrence Berkeley Laboratory; the Continuous Electron Beam Accelerator Facility; the High Power Laser Experiment at Boeing; the United Kingdom Infrared Telescope and the Keck II Telescope in Hawaii; and the Bates Linear Accelerator at MIT. A number of licensed U.S. companies develop EPICS-based systems for commercial customers.

The EPICS tool kit is applied to another critical set of APS instrumentation: accelerator diagnostics. Much like the medical diagnostic equipment that monitor pulse rate and blood pressure, accelerator diagnostics monitor the vital signs of an accelerated charged particle beam.

The APS challenged diagnostics designers for a number of reasons, including the sheer size of the machine, the resolution needed from sensors, the number of components that must act in concert, and the number of radiation sources. A major requirement was that the accelerator shut down within 1 millisecond if the particle beam drifts, causing a missteered ID beam. The interior of storage ring vacuum chambers could reach unacceptable temperatures if hit by a 10-kW ID beam. The machine protection system that guards against this type of mishap aborts an ID beam in less than 1 millisecond by interrupting the low-level rf that powers storage ring accelerating cavities.

The APS beam diagnostic system records particle beam position, shape, current, bunch length, energy, and beam loss in order to maintain beam stability. Injector and storage ring diagnostics include flags, beam current monitors, beam-loss monitors, and visible-light synchrotron radiation monitors. The heart of the system is the set of rf beam-position monitor (BPM) "button" pickup elements and their electronics. The pickups are mounted on vacuum chambers. Every 250 microseconds (the time it takes for 64 turns around the storage ring at 7 GeV), BPM electronics acquire new data on particle-beam position. During that same .25 millisecond, this information is sent by a digital orbit feedback system to the 80 storage ring power supplies, while 20 power-supply data processors are simultaneously informed of the corrections being performed by the other 19. Other data are provided by beam profile screens and synchrotron radiation from at least one bending magnet in both the booster and storage rings. The entire system was prototyped and then tested at existing light sources.

Radiation from insertion devices and bending magnets is monitored, corrected, and controlled while traversing an 80-meters-long beamline from storage ring to experiment station. Insertion device x-ray beams hotter than the surface of the sun must arrive with an accuracy greater than a micron, 100th the width of the average human hair. After the ID or bending magnet, a typical APS beamline comprises a front end (FE), which confines the beam; a first optics enclosure (FOE), which houses optics to filter and monochromatize the beam; and beam transports, additional optics, and the experiment stations.

Beamline front ends assure personnel safety, maintain storage ring vacuum, collimate the beam to keep it away from the vacuum chamber interior, provide shuttering to absorb the full power of the beam during injection or in case of a vacuum failure, and monitor beam position for stability. Fixed masks to confine the beam; shutters that rapidly intercept the beam and isolate downstream components from the source; photon beam position monitors (PBPMs) to gather precise information on beam location; and various isolation valves, collimators, filter assemblies, safety shutters, and windows all must fit in the 7.5-m space between the storage ring and the ratchet-shaped wall that separates ring and experiment hall.

At the APS, one type of FE carries ID radiation, and another begins at bending magnets. At the APS, ID front ends must tolerate at least 100-mA ring current and 7-GeV synchrotron energy. That is a heat level 3000 times greater than that from an electrical burner on a stove. The total power, peak heat flux, and beam width requirements of APS IDs, combined with limited space, tested the ingenuity of APS front-end designers.

Particularly challenging were the photon beam position monitors. A typical PBPM uses four small metal blades oriented to be brushed by the photon beam. The interaction of blade and beam generates photoelectrons, causing micro-ampere-level photo current. Seventy to 100 times per second, the APS photon monitors send data about beam position to computers. The computers make minute adjustments to

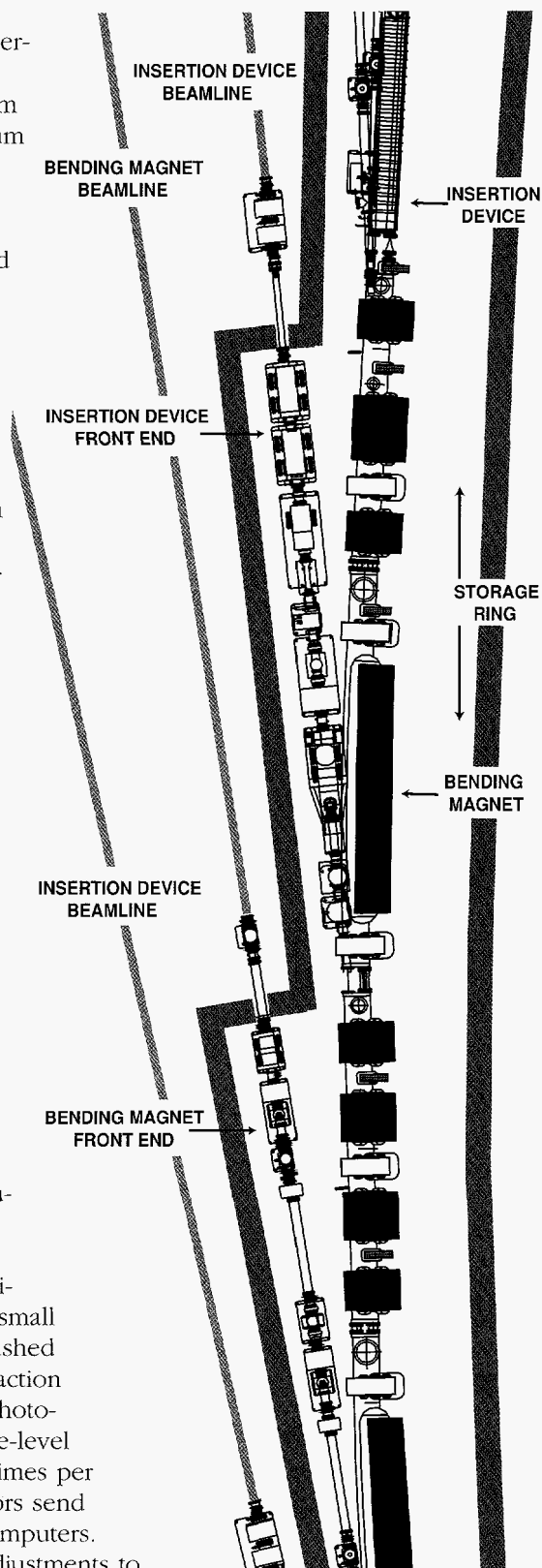

storage ring steering magnets, keeping the x-rays precisely on target. In a worst-case situation, a PBPM can instantly shut down a missteered ID beam.

Photon monitors used at other light sources were not suited to the APS, where ID x-ray heat poses a threat to conventional components. The solution was to make blades using synthetic chemical-vapor deposition diamond. Because diamond is an excellent thermal conductor, the APS photon monitors can withstand temperatures greater than 1000° C (in use, the blades are limited to 600° C of exposure). Heat is conducted to a copper block, and then to a cooling water bath. Diamond, however, is a poor electrical conductor at low to moderate x-ray energies, and therefore cannot send signals to the monitoring electronics. The PBPM blades are coated with a good electrical conductor such as aluminum, tungsten, or carbon graphite.

A new PBPM developed at the APS, called a transmitting monitor, takes advantage of diamond's transparency to x-ray. It sits directly in the beam path so that x-rays pass through the center of a diamond blade overlaid with a number of metallic strips, much like a printed circuit board. Because these strips surround the beam, the monitor gives a complete profile of the beam's shape and strength, as well as its position. Two patents have been issued to APS researchers for these monitors.

The wall between storage ring and experiment hall is also a line of demarcation. The 35 sectors marked onto the experiment hall floor are the domain of APS users. They are responsible for funding and constructing their beamlines, and they manage their sectors. With all APS sectors equipped and operating, the APS will in effect have 35 discrete laboratories under one roof.

User beamlines comprise crystal and/or mirror optics designed to tailor the photon beam for specific types of experiments. X-rays are delivered to an experiment station (or hutch), which contains the sample under investigation, additional optics that may be needed to analyze and characterize the scattering, absorption, or imaging process, and detectors. The average investment by each CAT for beamline equipment is \$8 million per sector.

The APS assists research teams with beamline development in several ways.

- A set of standard beamline components has been designed. These masks, filters, shutters, windows, even the steel "hutches" that house experimental apparatus, are common from one beamline to the next.
- An APS Design Exchange, accessible to users via the Internet and the World Wide Web, serves as a repository for computer-aided design (CAD) drawings of the standard components. From workstation computers at their home institutions, users can download the CAD files and piece them together into a beamline design. The standard components themselves can be supplied by the APS.
- Metrology and mirror-deposition labs have been established in the experiment hall. This proximity means that researchers can have beamline optics made to their exact specifications.
- The APS Experimental Facilities Collaborative Research Program provides a mechanism by which users and ANL staff can collaborate on jointly funded research to develop synchrotron radiation instrumentation for use on APS beamlines.

High-brilliance APS x-ray beams deposit extremely high heat loads on beamline optics. This is especially true of first optical elements in the FOEs, usually monochromating crystals made of pure silicon. X-ray radiation from APS front ends contains a wide range of wavelengths. Monochromators select out about one part in a million from the wavelengths that are carried by the ID beam, and pass

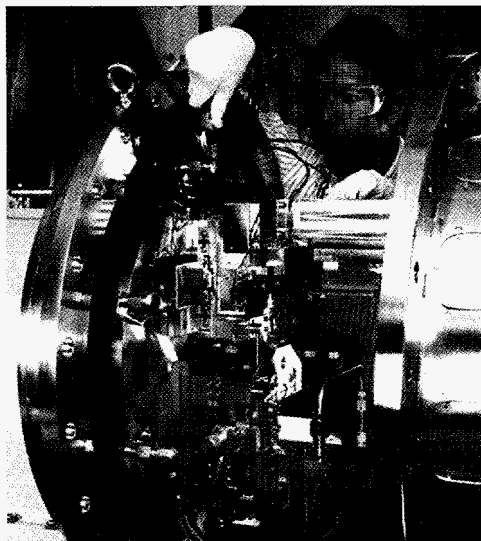

Perfect silicon crystals for monochromating x-ray beams are mounted in vacuum/mechanical housings, shown above.

that narrow band down the beamline to experimenters.

A highly collimated APS x-ray strikes the first optical element as a concentrated beam with a power density from 1 to 10 kilowatts. At its peak, that can be 300 watts per square millimeter (150 w/mm² at the typical location of the first optical component) — greater than the power density of electron-beam welders used to melt metal. Left to the mercy of an x-ray beam, the crystals would melt or fracture.

An Argonne R&D program found that liquid gallium was an excellent coolant. A high-rate, vibration-free electromagnetic induction pump developed at APS flows gallium through channels

cut in the crystals without disturbing the optical alignment. This pump technology has been licensed to a spin-off company which is developing tubes that continuously produce x-rays, and promise to be cheaper, longer-lasting, and more rugged than existing tubes. This tube could improve the efficiency of hospital procedures as well as industrial inspections of airplane components, metal castings and welds, and structural components in buildings, bridges and other structures.

While liquid gallium is an improvement over previous cooling techniques (such as water), eventually ID technology advances to a point where the coolant is no longer the deciding factor in whether or not monochromator crystals perform as required. At this point it is the intrinsic thermal and mechanical properties of the (room temperature) silicon crystals that will ultimately determine whether or not the enormous power densities are tolerated. In some cases, that point has already been reached. The future of monochromator cooling technologies seems to rest with two options: improve the thermal and mechanical properties of the silicon monochromator crystals by operating them at cryogenic temperatures, or use synthetic diamond for monochromator crystals. The end result of both approaches is basically the same: increase the thermal conductivity and reduce the coefficient of thermal expansion as compared to room temperature silicon, resulting in improved performance by high-power monochromators. The APS is working with ESRF and SPring-8 to develop closed-loop liquid-nitrogen cooling systems, and to acquire large, good-quality synthetic diamonds for this use on the frontier of synchrotron light source technology. ●

APS DESIGN PARAMETERS

● LINAC

- 200 MeV e⁻ (1.7 A)
- 450 MeV e⁺ (8 mA)
- Rep Rate: 60 Hz
- Length: 40 m

● POSITRON ACCUMULATOR

- 450 MeV DC ring
- 24 linac pulses per .5 sec
- Damp positron emittance
- Circumference: 31 m

● BOOSTER

- 450 MeV to 7 GeV in .25 sec
- Rep Rate: 2 Hz
- Circumference: 368 m

● STORAGE RING

- 7 GeV: 100-300 mA
- Lattice: Chasman-Green (40 periods)
- 352 MHz: 1296 buckets
- Filling times: under 1 min (100 mA)
- Circumference: 1104 m

RESEARCH TECHNIQUES AT THE APS

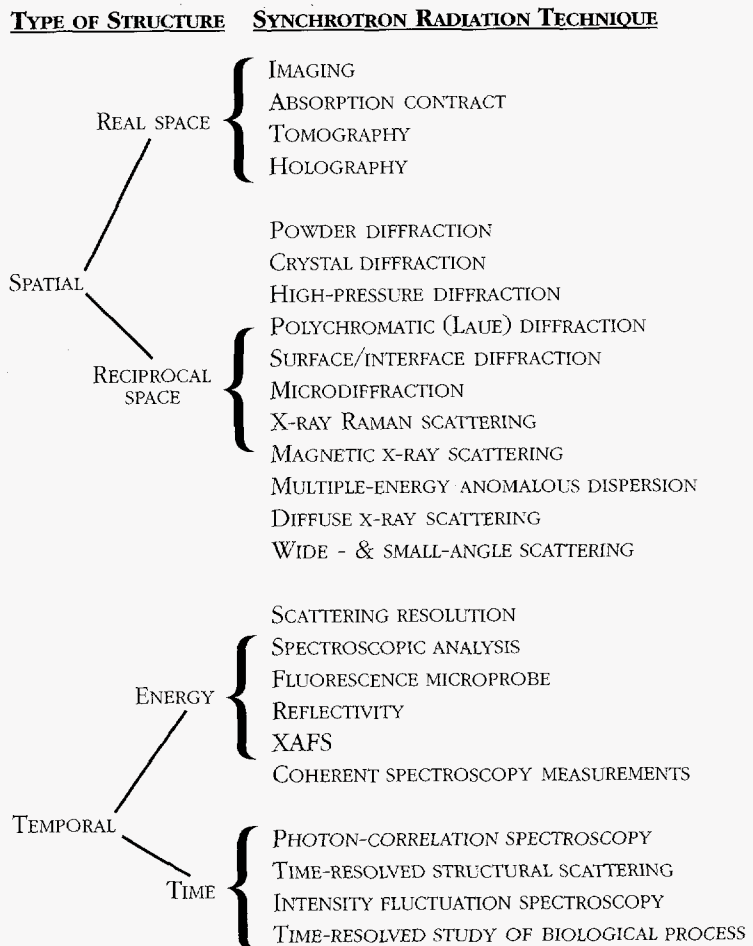

NOBEL PRIZES FOR X-RAY RESEARCH

1901	Discovery of x-rays	W. Röntgen
1914	X-ray diffraction by crystals	M. von Laue
1915	Determination of crystal structure	W. H. Bragg & L. Bragg
1917	Characteristic x-rays of elements	C. G. Barkla
1924	X-ray spectroscopy	K. M. Siegbahn
1927	X-ray scattering by electrons	A. H. Compton
1936	Diffraction of x-rays and electrons in gases	P. Debye
1962	Hemoglobin structure	M. Perutz & J. Kendrew
1962	DNA double helix	J. Watson, M. Wilkins & F. Crick
1964	Structure of vitamin B₁₂	D. C. Hodgkin
1976	Chemical bonding in boranes	W. N. Lipscomb
1979	Computed axial tomography	A. M. Cormac & G. N. Hounsfield
1985	Direct-method crystallography	H. Hauptman & J. Karle
1988	Photosynthetic reaction center	J. Deisenhofer, R. Huber & H. Michel

QUICK FACTS ABOUT THE ADVANCED PHOTON SOURCE

- **Funding agency:** U. S. Department of Energy, Division of Energy Research, Office of Basic Energy Sciences
- **Location:** Argonne National Laboratory, Argonne, Illinois
- **APS construction cost:** \$467 million
- **Construction start:** Spring 1990
- **Research start:** Fall 1995
- **Scientific disciplines to be investigated by APS Collaborative Access Teams:**
Materials science; biological science; chemical science; agricultural science; environmental science; geoscience; atomic, molecular, and optical physics; development of novel instrumentation
- **Number of Collaborative Access Teams currently formed to conduct research at the APS: 15***
 - *Number of universities participating in these proposals:* 102*
 - *Number of industries:* 36*
 - *Number of research institutes:* 17 (including 3 federal agencies)*
 - *Number of medical schools:* 9*
- **Anticipated number of visiting researchers per year:** ~2000 (300-400 at any one time)
- **Number of Advanced Photon Source staff at operation:** ~375
- **Primary research tool:** Brilliant x-ray beams
- **Vacuum in the storage ring (beam on):** $\sim 10^{-9}$ Torr
- **Charged -particle in the storage-ring beam:** Positron (electron with a positive charge)
- **Operational energy of positrons in the storage ring:** 7 GeV (approximately the speed of light)
- **Nominal beam lifetime in the storage ring:** 10 hours
- **Number of insertion-device beamlines available at completion:** 35
 - *Radiation from undulator insertion devices:* high brilliance, tunable energy from 3 keV to 50 keV
 - *Radiation from wiggler insertion devices:* very intense and energetic, with a broad range of energies from 5 keV to several hundred keV
- **Number of bending-magnet beamlines available at completion:** 35
- **Characteristic energy of APS bending magnet:** 19.5 keV
- **Storage-ring circumference:** 1104 meters (3640 ft, $\sim 2/3$ mile)
- **Outer diameter of the APS experiment hall:** 390 meters (1300 ft)
- **Height of the Sears Tower in Chicago:** 436 meters (1454 ft)
- **Concrete used in construction of the APS experiment hall:**
54,600 cu yds (including 1,600 cu yds of heavy-weight concrete for shielding)
- **Structural steel used in construction of the APS experiment hall:** 5800 tons
- **Wire used in construction of the APS experiment hall:** 600,000 meters (2,000,000 linear ft)
- **Total gross floor space of all APS buildings:** 86,310 m² (959,000 sq ft)

- For additional information on the APS, call (708) 972-5280,
or write to Advanced Photon Source, Argonne, IL 60439

- For information on Argonne National Laboratory, call the Argonne Office of Public Affairs, (708) 972-5580,
or write to Office of Public Affairs, Bldg. 201, Argonne, IL 60439

* As of 10/95