

FILE COPY
NO. 1

TECHNICAL MEMORANDUMS
NATIONAL ADVISORY COMMITTEE FOR AERONAUTICS

No. 944

ITALIAN HIGH-SPEED AIRPLANE ENGINES

By G. F. Bona

Paper presented at Volta meeting in Italy
September 30 to October 6, 1935

THIS DOCUMENT IS ON LOAN FROM THE FILES OF

NATIONAL ADVISORY COMMITTEE FOR AERONAUTICS
LANGLEY AERONAUTICAL LABORATORY
LANGLEY FIELD, HAMPTON, VIRGINIA

RETURN TO THE ABOVE ADDRESS

REQUESTS FOR PUBLICATIONS SHOULD BE ADDRESSED
AS FOLLOWS:

NATIONAL ADVISORY COMMITTEE FOR AERONAUTICS
1512 H STREET, N. W.
WASHINGTON 25, D. C.

Washington
June 1940

NATIONAL ADVISORY COMMITTEE FOR AERONAUTICS

TECHNICAL MEMORANDUM NO. 944

ITALIAN HIGH-SPEED AIRPLANE ENGINES*

By C. F. Bona

INTRODUCTION

The object of the present paper is to give an account of Italian high-speed-engine designs. By high speed is meant the speed attained at low altitude by exceptional pilots flying exceptional airplanes where streamlining, weight, wing area, and ease of handling have all been sacrificed for the attainment of the single object of high speed.

For many years, high speed in aviation has been associated with the name of Jacques Schneider, who, in 1913, initiated the Schneider Trophy Competition for seaplanes. In this competition there participated at first standard airplanes with standard engine, but later, with interest in the competition growing, the airplanes began to be equipped with engines of "forced" design, that is, engines otherwise standard except that their power was increased by an increase in the compression ratio. Finally, in recent years, with engine powers rapidly increasing, it was no longer sufficient to increase the engine compression ratio merely but it became necessary to design engines intended exclusively for the races. The graph on figure 1 shows the increase in the powers employed in the successive Schneider races as a function of the speed attained.

With increase in the power, the problem became more and more beset with difficulties on account of the limited time available for the preparations, so that the annual competition became a biennial one. Finally, it became necessary for the governments of the various states to intervene to bear the costs of the preparation, which had become so great that they could no longer be borne by private initiative. The race thus acquired the character

*"I notori italiani per gli apparecchi di alta velocita." Paper on High Speed in Aviation, read at the 5th Volta Congress, at Rome, September 30 to October 6, 1935.

of a truly national event and possession of the Schneider Cup became an honor highly aspired for by the aviation interests of the various countries. The regulation was then introduced that in the last race the winning airplanes should compete also for speed records based on the distances of 3 and 100 kilometers, respectively.

With the competition ended and the final granting of the cup to England, another race, again due to the generous initiative of France, took the place of the Schneider competition, namely, the Bleriot Cup instituted by the glorious pioneer of aeronautics and granted provisionally to whoever first exceeded the speed of 600 km/h (372.84 mph) for 30 minutes of flight and finally to whoever first attained the speed of 1,000 km/h (621.4 mph).

Italy, which with the coming of the Fascist era had put the aviation problem first in its task of reconstruction undertaken by the national government, evidently could not be disinterested in such an important exhibition wherein the achievements of its airplane and engine technology, its industrial organization, and the heroism of its pilots could be displayed before the world. Spurred by the enthusiasm of the Duce, Italy participated three consecutive times in the Schneider Cup races and, although absent from the fourth and final race after having made desperate and heroic efforts to participate in it, by taking the speed prizes for the 3- and 100-kilometer races and winning the Bleriot Cup demonstrated the quality of her aircraft and the valor of her pilots, who not only could beat records that required a few minutes of flight but could fly at very high altitude for a time equal to and above that required by the Schneider Cup races.

HIGH-SPEED ENGINES

It would be outside the scope of the subject assigned to me to enter upon a detailed discussion of the problem of the high-speed or racing engine. I shall therefore limit myself to outlining the chief features. This will help better to understand the nature of the difficulties which had to be faced and overcome in the design of the Italian seaplane engines.

An essential requirement for high-speed flight is that of minimum possible weight of the engine in comparison with the power developed. The weight of the engine is

here taken in its widest sense to include the following component weights:

- a) Weight of the engine proper;
- b) Weight of the engine cooling system;
- c) Weight of the fuel and lubricating oil.

If the weights per horsepower of a racing airplane engine are compared with those of a standard engine, there is found a ratio between them of 0.5 approximately. This was as true in 1934 as in 1927. This means that, since the racing engines in 1934 have attained a unit weight about 0.8 times that of 1927, the standard engines, too, have progressed with the years although not to the same degree as the racing engines. In other words, it may be stated that the progress of the racing engine achieved under the spur of keen sport competition has exerted its beneficial influence also on standard engines and thus contributed to the continued development of aviation. This fact is easily explainable when it is reflected that the problems of the racing engine are no other than those of the airplane engine in general carried to their extreme and the functioning of any mechanism at its limit of operation is always a fruitful source of useful information.

A reduction in weight as low as that set by the goal can evidently not be attained in a racing engine if it is desired to maintain life guarantees of the engine equal to those given to standard engines. Racing engines may be intended for a much shorter life of some hours only.

Lightness is obtained in two distinct ways:

- a) By increasing to the maximum the breathing capacity of the engine per unit time and hence for a given power decreasing the cylinder displacement and raising the engine speed and boost pressure;
- b) By reducing the weight of the various components, which reduction can be attained by accepting a suitable increase in the admissible stresses either through the use of special lighter and stronger materials or by executing a specially difficult and expensive design which would not be acceptable in normal series production.

An increase in the speed can be supported by the engine only on condition of reduced reciprocating and rotating masses. Moreover, it is known that cooling of the pistons and valves is more readily attained in cylinder units of small dimensions. Both of these circumstances lead to a subdivision of the total cylinder displacement among a large number of cylinders. On the other hand, the advantage of a large number of cylinders is offset by the disadvantages of large frontal area and of large weight per unit cylinder volume, disadvantages which become more serious with increase in the number of cylinders. The choice of a happy compromise among these conflicting factors is a test of the skill of the individual designer.

In order to keep down the weight of the cooling system, it is necessary that the heat yielded to the cooling liquid should be the minimum possible compatible with the temperatures of the pistons, valves, and spark plugs, which temperatures must be held within acceptable limits for good engine performance. The design of the cylinder, the material of the explosion chamber, the shapes and lengths of the exhaust passages, the degree of compression, the amount and quality of the cooling liquid have a great effect on the heat given up to the cooling liquid. Among the liquids employed, the most common is water but liquids can also be used with high boiling points such as ethylene glycol, which thus permit a higher temperature of the cooling medium with the resulting decrease in the radiator surface. This advantage is offset, however, by not a few disadvantages due to the low specific heat of the glycol and its viscosity characteristics which make it necessary to increase the quantity of the cooling liquid. Furthermore, the high cycle temperatures that result may injuriously affect the cooling of the pistons and valves. There is also an increase in the heat given up to the oil resulting in an increase in the area and weight of the oil radiator.

The quantity of heat given up to the lubricating oil also has an important effect on the weight of the oil radiator as have also the capacity of the oil pump, the clearance of the bearings, the type of piston, the efficiency of the supercharger and radiator, the temperatures of the cooling liquids, etc.

The weight of fuel and lubricating oil is directly proportional to their consumption. Particularly difficult

is the problem of reconciling low fuel consumption with the high power output of modern engines, which is obtained by the use of the supercharger, a member requiring for its operation from 6 to 10 percent of the engine power and the problem becomes still more difficult when evaporation of the fuel is resorted to for cooling the fuel mixture and thus increasing the volumetric efficiency.

Another difficulty is presented in keeping down the large oil consumption due to the high crank speeds and reduced crankcase size conditions which facilitate the leakage of oil into the combustion chamber.

Another important requirement of the racing engine is low frontal area. Engines of reduced transverse sections and much elongated lend themselves admirably to fairing in with the fuselage with resulting high aerodynamic efficiency. In seaplanes generally the engine is located ahead of the pilot. The ideal cross section is that which is reduced so as to be no larger than the frontal area of the pilot's body. Of all engines, this ideal is most closely approached by the 12-cylinder engine arranged in two rows of six, forming between them an angle of 60° . This explains why all racing seaplanes have so far been water-cooled. In fact, air-cooled engines which present such advantages of lightness compared with the former do not lend themselves to efficient cooling with this in-line arrangement of the cylinders. Good confirmation of this fact has been obtained in the Deutsch de la Meurthe race where, however, small power engines were involved. Care must be taken in the entire engine design to reduce any projections and to strive for a good streamline shape. The propeller gear with the axis of the propeller displaced with respect to the crankshaft is from this point of view a good solution because it brings the propeller axis almost at the center of gravity of the cross section.

Other requisites of the racing engine are good visibility, absence of poisonous gases in the vicinity of the pilot, and correct fuel supply under conditions of curved flight when the accelerations of the motion tend to disengage the feed pump.

I shall close these remarks on the general problems of the racing engine by referring briefly to that of the choice of the fuel. The problem of maintaining the mean effective pressure of an engine at a value of 11 - 12 kg/cm^2 , as in the case of a non-supercharged engine with

high degree of compression is relatively simple, since the fuels should be restricted to those which can support the high degree of compression without detonation and can readily vaporize in the short interval available of passage from the carburetor to the cylinders so that good fuel distribution and good acceleration may be obtained. Moreover, there should be no excessive tendency toward ice formation on the carburetor valves.

The problem of fuel consumption in these engines is rendered less difficult by the high thermal efficiency due to the high compression so that in these engines fuel mixtures can be used that contain substances of high latent heat that may be utilized for cooling the hot cylinder parts without excessive increase of the fuel consumption.

In considering supercharged engines with high mean effective pressures (14-16 kg/cm² (200-227 lb/sq in.)), the problem of the choice of fuel becomes much more difficult. The principal requirements become:

- a) Complete absence of detonation notwithstanding, the high temperatures of the intake air and the presence of hot points in the cylinder.
- b) High latent heat of vaporization necessary for reducing the air temperature at the compressor exit and thus increasing the volumetric efficiency and hence the power of the engine.
- c) High calorific value of the fuel in order to obtain low fuel consumption.

While requirements a) and b) are compatible with each other in the sense that the addition of substances of high latent heat to the mixture in general increases its anti-detonating power, requirements b) and c) are completely incompatible with each other since substances that possess high vaporization heats are unfortunately of low calorific value. It is true that the cooling effect can equally well be obtained by the use of rich mixtures consisting of fuels of high calorific value but this, too, is in the end detrimental to the fuel consumption. The choice of the most suitable fuel must therefore be a good compromise based on the results of many tests.

Another important requirement is the volatility, which,

in addition to having an effect on the fuel distribution and on the acceleration, decreases the tendency toward condensation, which is very strong under idling conditions.

ITALIAN ENGINE DESIGNS

The engines designed by Italy to take part in all these four races were predominantly of the Fiat type suitably modified for the races. They were denoted, respectively, as AS2, AS3, AS5, and AS6, and all were water-cooled.

The AS2 won the Schneider Cup of 1926; the AS3 won the absolute speed record of 1928 and was awarded second place in the Schneider Cup race of 1929; and the AS6 holds the absolute speed record for 3 and 100 kilometers and the Bleriot Cup. Although the AS5 gave brilliant results in the bench tests, being extremely audacious in design, it did not have the opportunity to prove itself in the races. The experience gained with this 1,000 horsepower engine, which for some time remained the world's lightest engine with least frontal area, was very valuable, its design being used as a basis for the AS6. On table I are given the principal characteristics of these engines, while on figures 2 and 3 are shown the progress made in lightness and frontal area reduction. The weight per horsepower and the power per dm^2 of frontal area are taken as indices of lightness and frontal area, respectively. The great progress in the reduction of the frontal area as appears in the case of the AS6 is due to the coupling of two engines in tandem while actually the minimum dimensions in absolute value were attained on the AS5, which, as is evident from figure 4, had reached the lower limit given by the frontal area of the pilot's body.

The AS2, AS3, and AS5 were without supercharger. On the AS5, the speed was raised to 3,200 as compared with 2,400 of the AS3 and 2,300 of the AS2. The bore was 138 mm as compared with 140 mm of the AS2 and 145 mm of the AS3, while the stroke was reduced from the value of 175 mm of the AS3 to 140 mm, reducing the velocity through the valves and thus maintaining the same efficiency as the AS3 in spite of the increased mean piston speed.

In all these engines, as also in the AS6, the same cylinder type characteristic of the Fiat design was maintained (fig. 5). The cylinder is of cast steel and has four valves, two intake and two exhaust. The induction pipes were particularly short and were welded to the cyl-

inder head. The ensemble is then stiffened by three roof plates welded to the pipes. Around the cylinder and pipes is welded a thin steel sheet, thus forming the water jacket. The explosion chamber is cylindrical with two diametrically located spark plugs, one on the intake and the other on the exhaust side. This design, except for the change in dimensions, was maintained identical in the four engines referred to and was found to give good performance except for some small difficulty which was due to the loss of water by the welds, but this difficulty was easily removed. The aluminum monobloc construction was not used because it is heavier and of greater frontal area than the welded steel structure. When, in connection with the AS6, tests were conducted with single cylinder engines to investigate the behavior of the Fiat cylinder with supercharger, one of the other favorable characteristics of this type of construction was brought out, namely, the limited quantity of heat given up to the water. This might have raised some fears as to the efficiency of cooling of the valves but by small modifications a good compromise was found without foregoing the characteristic of small heat loss to the water which, as already mentioned in the introduction, brings marked advantages of reduced weight and frontal resistance of the cooling system.

This type of construction slightly modified was therefore maintained also on the supercharged engine and was found to give good performance with mean effective pressures above 17 kg/cm^2 (242 lb/sq in.). Another advantage presented by this design is that by having the cylinders independent, replacement of any cylinder when necessary was possible without changing the others. This is a valuable advantage for racing engines where every minute saved may greatly affect the results.

The compression ratios employed on the engines without supercharger increased from the value 6 of the AS2 to 6.7 of the AS3 to 8 of the AS5. The shape of the explosion chamber was found to be perfectly suitable for such high compressions and the AS5 with a compression ratio of 8 employed a fuel of less than 94 octane number without giving any indication of detonation.

The valve gear system typical of the Fiat construction was likewise maintained in all of the four racing engines but was suitably lightened in structure. The AS5 was notable for the good behavior of its valve springs notwithstanding the high rotational speed. On the AS3,

tests were conducted with pistons of magnesium alloy with unsatisfactory results.

During the conditioning of the AS5 much trouble was encountered by very high oil consumption. A remedy was found by the design of a crankcase of large dimensions so as to constitute an oil sump for the atomized oil thrown around the crank. The forward part of the crankcase was streamlined and without cowling at the front of the fuselage, so that by being directly exposed to the air stream it served as an efficient oil radiator, permitting a decrease in the area of the radiator itself (fig. 6). Also the end covers of the cam housings were streamlined to the shape of the fuselages and were uncowed and exposed to the relative wind.

Other members which were maintained more or less similar to those corresponding to the normal design were the connecting rods and crank shafts. All the engines used white babbitt metal bearing.

In order to increase the volumetric efficiency of the AS2, AS3, and AS5, three carburetors were located in the V of the cylinders. The AS2 and AS3 had an aluminum base. On the AS5, magnesium was used for the first time. This material, however, showed a low resistance to repeated stresses and gave rise to several cracks. None of the three engines (AS2, AS3, and AS5) was provided with a reducing gear, the latter being introduced for the first time on the AS6.

THE FIAT AS6 ENGINE

We now come to a discussion of the AS 6 whose design was the product of the greatest effort of Fiat in the field of racing engines.

Problems of design.- We have already referred to the every increasing power requirement imposed by the Schneider Cup competition. Solutions based on maintaining 1,000 horsepower with reduction of weight and frontal area pushed to extreme limits as that conceived by Fiat for the 1929 race when the AS5 was designed, gave rise to serious difficulties because of instability in taking off and landing. Radical solutions like those of Pegna based on the elimination of the floats proved themselves removed from the possibility of any immediate production as a long preliminary conditioning period would have been required. It was thus

impossible to avoid the increase in power imposed by the circumstances. In 1929 the English won the Schneider Cup with a 1,900 horsepower engine. In the same year, E. Crocco, at that time Director General of Aeronautical Construction, imposed in the specifications for the 1931 engine a minimum power of 2,300 horsepower that should furthermore be obtained with a weight not exceeding 840 kg and with a fuel consumption not exceeding 250 grams. In order to satisfy these conditions, Fiat was confronted by problems of considerable difficulty since the experience gained with the AS5 was based on a power of 1,000 horsepower with a weight-volume ratio of 40 horsepower per liter and a mean effective pressure of 11.2 while now it was necessary to more than double the absolute power and go above 46 horsepower/liter and 14 kg/cm² (199 lb/sq in.) mean effective pressure by employing a supercharger and propeller gear which at that time were still in the experimental stage.

In order not to deviate too far from the experience gained on the AS 5 consideration was given to the coupling of two AS5 units in tandem. Such a solution was extremely suggestive for the following reasons:

1. The limited frontal area, not much exceeding the limit attained with the AS5, while the ratio of horsepower per unit frontal area could assume very high values.

2. Possibility of profiting by the experience already gained on the AS5, whose stroke, bore, and speed were retained.

3. Possibility of a central location of the propeller reducing gear between the two engines, by having the propeller axis pass through the V of the forward engine with the threefold advantage that the axle was strongly supported against the effects of the gyroscopic couple, the long axle itself constituted an elastic coupling between the propeller and the reducing gear and the displacement of the propeller axis with respect to that of the engine was favorable to extremely good fairing with the fuselage.

4. The large cylinder displacement that thus became available permitted the ready attainment of the power specified without the need for excessive supercharging of the engine, thus maintaining the exceptionally low fuel consumptions imposed in the specifications. With moderate supercharging, a high degree of compression was still admis-

sible ($\rho = 7$) with the consequent advantage in low fuel consumption to which was added the advantage that the compressed air temperatures, not being too high, it was not necessary to employ fuels with high latent heat but with necessarily low calorific value.

To these four advantages that acted in favor of adopting the solution of doubling the AS5 unit, there was added still a fifth and fundamental one, namely:

5. The possibility of readily utilizing the counter-rotating-propeller principle. This idea, which was not new in aeronautical application since it was already a subject of the patents of Bréguet, Deperdussin, and Renault in the early stage of aeronautics and in the problem of the seaplane found a new field of application capable of many advantages. The principal ones were: the small propeller diameter which greatly facilitated the airplane construction; the compensation for the reaction and gyroscopic couples, and the straight and non-vortical slipstream by which the exhaust gases were prevented from passing near the pilot, bringing serious disturbance in the breathing and visibility.

The weight of the two propellers was practically the same as that of a single propeller with equal power and tests conducted at Varese with floats had shown that the thrust of two propellers rotating in two planes very near each other was slightly above that of the sum of the single thrusts of each propeller rotating separately. If it had been desired to adopt a single propeller, it would have been necessary to join the two crankshafts, then to reverse the total power of the two engines through the gear at the single propeller shaft. This might have given rise to the serious torsional vibrations of a long crankshaft with twelve cranks that would result from such a coupling or, if special coupling joints with vibration dampers were provided, there would be an appreciable increase in the weight.

The adoption of two propellers permitted each engine to act as a separate unit, both as regards the mechanical side and the ignition. The supercharger, however, which on account of its shape was most naturally located in the afterpart of the rear engine was designed together with the carburetor and the intake pipes as a common unit to the two engines. (See figs. 7, 8, and 9.) This characteristic and original supercharger arrangement gave rise to a large variation of the power available for the two

propellers, so that the forward propeller which was connected to the rear engine which drove the supercharger was found to absorb 200 horsepower less than the rear one. This, however, did not lead to any trouble, since by adjusting the pitch it was possible to obtain sufficiently equal rotational speeds for the two propellers.

Having thus outlined the salient features of the AS6 which, although it was composed of two mechanically independent units, was considered as a single engine being supplied by a single fuel feed system, I shall indicate the problems that were to be confronted, enlarging on some of the details in a later section since many of the parts received their final form after tests. (See figs. 8 and 9.)

The novelty was in the counterrotating propeller drive. From the propeller gear located at the center of the engine and consisting of two spur wheels passed two hollow shafts rotating one within the other. These turned on bearings located at the two ends, no intermediate support being provided. On the low speed side, each gear wheel was rigidly fixed to the respective shaft and was supported by two bearings, the one a roller and the other a ball bearing which also served as a propeller-thrust bearing. On the hub side of the propeller, the inner shaft rotated on a roller bearing supported by the outside shaft which, in turn, was supported by the base on two smooth bearings. Between the two supports, the inside shaft had a free length of 1.6 meters (5 ft 3 in.). The critical speed of the shaft was therefore verified by computation and was found, with the section under consideration, to be double that of the engine speed. This safety factor was considered more than sufficient and also turned out to be so in practice.

A difficult problem was presented by the roller bearing between the two hubs. This bearing was to be under load only during turns and was to take care of the effect of the gyroscopic couple of the forward propeller but it rotated at 3,900 revolutions per minute and was unable to receive forced lubrication. Tests were therefore conducted at the O.V.P. bearing factory and the bearing after 50 hours of rotating at 4,000 revolutions per minute under 200 kg (441 lb) load and light lubrication was found to be in perfect condition.

In order to lighten the construction as much as possible, the propeller hubs which permitted blade adjustment on the ground were formed of a single piece with the shaft.

Advantage was taken of the central portion to locate therein not only the propeller-reducing gear but also the drives of the cams and of the water and oil pumps. It was necessary to make the gear housing stronger than otherwise required because to it were anchored the wings and it was necessary to take into account thousands of kilograms which acted on the gear cover at the instant of landing.

Even in making use of the parts of a known engine like the AS5, the design of the thermally loaded parts of the engine, the cylinder, the piston, and the valves had to be revised to take into account the increase thermal stresses caused by the considerable increase in the power required in the AS6 design. While the specifications imposed a minimum power of 2,300 horsepower, the engine was designed for 2,500 horsepower. Since the supercharger consumed about 200 horsepower, the mean effective pressure to be considered in comparison with that of the AS5 was referred to the total power, including the supercharger. It was therefore considered increasing the 11.2 kg/cm^2 (159 lb/sq in.) of the AS5 to at least 14 or 15 kg/cm^2 ($199 \text{ or } 213 \text{ lb/sq in.}$). The parts were therefore redesigned and finally modified on the test bench, as will be described more in detail in the section below.

The distance between the cylinder axes was reduced to a minimum for reasons of weight and length. The water passages around the combustion chambers between one cylinder and the other were reduced to a minimum so that the distance between the two diameters of the cylinders at that point amounted to only 16 millimeters (0.63 inch). The construction of the cylinder of welded steel with corresponding jackets was found to be clearly superior to the monobloc construction of cast aluminum which in this respect would have required not less than 23 millimeters (0.90 inch).

At first, only two water pumps were provided, each feeding two rows of six cylinders. Following the results of tests on the single cylinder, the number of pumps was raised to four, one for each row of six cylinders in order to increase the quantity of cooling water.

The ignition, for reasons of weight, was by battery. It was found that the system consisting of four generators with the battery and charging dynamo weighed 10 kilograms (143 lb) less than four magnetos and their drives of the

type then available. The generators were conveniently located at the end of the cam boxes. It will be seen in what follows what serious difficulties this arrangement gave rise to.

The main- and connecting-rod bearings were found to be very highly loaded, as may be seen from table II on which are given the values $p \times v$ of the AS6, AS5, and a standard engine. It was therefore decided to use lead bronze, which, however, was abandoned following the results of the test.

The crank shafts were of dimensions equal to those of the AS5 and were found to endure very well the increased stresses.

In order to have exact alinement of the two crank shafts, the entire engine base was of one piece for which reason, to facilitate casting, it was divided into two sections in the plane of symmetry of the reducing gear. Since the support bracket of the fuselage closed at some point on the base, subjecting it to uncontrolled stresses and since the considerable length rendered it very flexible in torsion, the base structure was provided with much greater rigidity than the ordinary Fiat designs. A double wall was arranged all along the flanks and the division between base and crankcase was made along a plane displaced downward with respect to the engine axis. In order to maintain this imposing structure within the limits of weight specified, it was necessary to employ magnesium as the material.

The supercharger did not constitute an entirely new problem for Fiat. In Italy, Fiat was the first to apply a supercharger for an internal combustion engine to increase the power and this was in 1923 on automobiles that participated in the races at Tours. The supercharger was of the reciprocating type. The first centrifugal supercharger was applied on a Fiat marine engine for motor boat and was mounted voluntarily to obtain a temporary increase in the power of the engine in embarking.

Never before, however, had Fiat been confronted with the problem of a centrifugal supercharger of such large capacity (5,000 m³/hr (176.57 cu.ft/hr)). The most singular feature was that of feeding two independent engines. This system had already found application in the last years of the war in some German designs of large bombing

airplanes provided with supercharger where the latter driven by an auxiliary motor fed two or more independent engine units. It was there a case of distributing pure air under pressure to distinct carburetors belonging to different engines. The feed system of each engine and the lengths of the pipes were not modified by the effect of the supercharging. The entire problem was therefore reduced to an experimental study of the perfect balancing of each carburetor under the new pressure created by the supercharger at the carburetor intake. In the case of the AS6, it would likewise have been possible to adopt the system of carburetors under pressure and during a certain period there was hastily equipped a variant of such a system that was then abandoned. This meant, however, locating the carburetors in the center of the V and although this was easy for the rear engine it was not so for the forward engine where the V space was occupied by the oppositely rotating propeller shafts. The carburetors, six in number, were very much reduced but the supercharge pipe still projected out beyond the engine, seriously affecting the visibility and streamlining of the seaplane. The weight increased appreciably and the regulation of six carburetors required a much longer time than that required by two.

It was therefore preferred to confront the unknown fuel distribution problems raised by a supercharger rather than give up these advantages. In what follows, something will be said of the extraordinary laboriousness of these tests that such solution required.

The supercharger consisted of two fused bodies of magnesium alloy, an impeller of forged aluminum alloy of rather large diameter, cantilever supported on three bearings, a bladed diffuser, followed by a spiral diffuser. The collector at the entrance was central without spiral intake and the blades of the impeller were not curved at the inlet to avoid the momentum losses. (See fig. 10.) Notwithstanding the defect of this arrangement and the very great air capacity, the adiabatic efficiency was still 0.56.

The supercharger was mounted with an axis displaced upward to permit the location of the fuel pumps at the lower part and for the same reason the carburetor was designed to be of the inverted type, thus facilitating the location of the air intake without wasting precious space.

At first the supercharger was coupled to the engine by means of a simple friction coupling, designed to disengage when the torque exceeded a certain value imposed by the resistance of the teeth of the multiplying gears. There were two of these with very high ratio. In the section below will be discussed the modifications that had to be made to obtain a satisfactory result.

The carburetor and the fuel-feed system were studied with the object of assuring an equal division of the fuel between the two tanks contained in the floats. This was necessary to avoid, after a certain time of flight, having one tank empty and the other full with the resulting strong weight disequilibrium that would render take-off and landing difficult and dangerous. The arrangements adopted on the AS5 and the corresponding airplane were based on the division in two equal parts of the overflow of the fuel pump but required a long adjustment and were not quite satisfactory. On the AS6, instead of a single circuit, two were arranged completely independent of each other (figs. 11 and 12). The carburetor was therefore divided in two each with a float chamber and four venturi tubes. Each circuit consisted of a reservoir contained in the float; a geared, high-capacity pump with corresponding overflow return in the float; a small auxiliary tank at atmospheric pressure containing a quantity of fuel sufficient for curved flight; an automatic regulating pump for giving a constant pressure at the carburetor, since it was not possible to raise the auxiliary pumps to create a gavity head; and, finally, the carburetor. With this system, the equal division of the fuel weight between the two floats was automatic, provided the fuel was equally divided between the two carburetors. The latter, opening into a single collector at the entrance of the supercharger were both subjected to a strictly equal vacuum. The entire problem was thus reduced to making sure that the quantity of fuel delivered by the jets of the two carburetors under the same vacuum was equal, a problem very simply solved by calibrating the carburetor jets. The system proved entirely satisfactory. It was only necessary to replace the automatic regulating pumps by other geared pumps made automatic by the adoption of a valve.

The starting was by compressed air suitably distributed by distributors driven by gears located on the reducing gear housing. Since the two engines were independent, the rear engine that was provided with the supercharger was first started. Then with the speed of the rear engine

slightly raised so as to create a pressure in the fuel pipe, the forward engine was rapidly started. The starting was always satisfactory.

Methods and Test Set-Up.- The preparation and conditioning of an engine of the AS6 type required a huge number of tests, which lasted over a period of almost a year and a half. Before enlarging on the problems of getting the engine in working order, I shall briefly refer to the methods used in the various tests.

Preliminary to testing the complete engine, investigations were carried out on various parts, namely, the cylinder, supercharger, carburetor, and on the two engines with and without supercharger. For the tests on the cylinder alone, a section of the base of the AS5 was utilized and a counterweighted crankshaft and a drive for the camshafts were constructed that permitted a displacement of the height of the cylinder by which its compression ratio was varied. Pistons and cylinders were those of the AS6. The compressed air of the laboratory was used for supercharging, the air being taken from a compressed-air tank provided with safety devices and led to the carburetor intake. These tests, while useful because they provided preliminary data on the fuel mixture, the effect of the degree of compression and supercharging, and particularly because they lent themselves to important measurements on the thermal balance and to studies on valve temperatures, involved many difficulties which were not reproduced on the engine such as internal cylinder cracks and cracks corresponding to the fixing flanges, etc., due to unavoidable vibration.

For the supercharger tests, an airplane engine of 400 horsepower and a multiplying gear was utilized in order to bring the supercharger more nearly under the true operating conditions. The supercharger took in air through a larger pressure tank provided at its mouth with a nozzle for measuring the quantity and discharged to the outside through a regulating valve which determined the various supply pressures. The supercharger was studied both in operation with pure air and with fuel-air mixture. Nevertheless, as will be seen below, with this system the real torque of the drive coupling that was found on the actual engine was not successfully reproduced.

When the complete engine was tested, three types of test stands were employed, one with hydraulic brake without

the air stream corresponding to flight, another with the propellers used as a brake, and a third with the apparatus for creating the air stream. It was necessary to study a double hydraulic brake which was designed by Fiat. One of the brake shafts was hollow and permitted the passing through it of the other brake shaft which turned in opposite direction to the first. A special coupling with a double Cardan joint was located between the engine and the hydraulic brake.

The first stand served for testing the engine without the relative wind. Four powerful blowers, one for each row of cylinders, discharged the exhaust gases, which were rendered poisonous by the presence of tetraethyl lead in the mixture, through special exhaust boxes that could be opened to examine the coloration of the flame and of the exhaust gases. The housing was rigid and was of cast iron.

With the engine accepted after an hour's test at full throttle on the dynamometer bench, the specifications provided for a second half-hour test on another stand that was to reproduce as nearly as possible the airplane installations. The airplane manufacturer furnished the engine mounting, the wing radiators, the cowling, and the fuel tanks located at a distance from the carburetor equal to the actual distance on the seaplane. The radiators were cooled by an artificial water spray. The propellers, which were like those on the actual airplane but with the pitch adjusted so as to attain the rotational speed in flight, produced on the fuselage a relative wind equal to that in flight and permitted study of the carburetion also under these conditions. The results obtained with this installation deviated, however, very much from those that were later obtained on the airplane and only gave apparent agreement.

It was on only the third test stand that exact reproduction of the flight conditions was obtained, the engines mounted on the seaplane giving rise to no "surprise" results. The set-up with the very large number of the installations covered a very large area of a big hangar as may be seen on the photograph (figs. 13 and 14). This set-up, which is still in existence, is provided with the double hydraulic brake already described and with a rigid stand.

An airplane engine with its propeller directs an air-

stream of moderate velocity on the test engine to remove the exhaust gases from the ambient air. Another airplane engine of 700 horsepower drives a two-stage blower which has a capacity of 230 m³/min (8,122 cu ft/min), the air attaining a pressure of 2,600 mm (102.4 in.) of water. The air is then cooled to a temperature of about 20° in two large, honeycomb radiators with water circulation. From here a pipe leads the air, thus compressed and cooled, to a nozzle located near the intake of the carburetor which transforms the pressure into a velocity adjustable up to a maximum of 750 km/h (466 mph).

The fuel tanks are lowered to a depth corresponding to the actual distance between the tanks in the floats and the entire feed circuit is the exact reproduction of that of the seaplane. The control board, where all the instruments are concentrated and also the remote control of the carburetor valves and spark advance, the flow meters for the measurement of the fuel consumption, the manometers for the air pressure and the air velocity, is provided with a signal system which permits transmitting to the blower board the indication of the required velocities. The blower board is slightly elevated and protected with a screen from the propeller stream and with the aid of mirrors permits the examination of the flame coloration in all the cylinders as well as the rapid inspection of the entire course of the test.

Problems Confronted in the Final Test of the Engine

The problems that came up during the laborious testing of the engine and the solutions proposed to solve them will be considered now, beginning with those parts of the AS6 whose design was similar to those already long experimented with on standard Fiat engines.

Cylinders.— Although the cylinders retained the same bore and stroke as the AS5, they were redesigned to incorporate the following modifications suggested partly by the tests conducted on the single cylinder:

1. Stiffening of the cylinder head by addition of a welded plate located between the pipes.
2. More efficient cooling of the exhaust-valve stems obtained either by extending the water circulation to a greater length of the valve guides or by carrying the water to the middle of each

cylinder rather than to the base in order to bring the water nearer the region of the spark plugs and valves, and adding a tube carrying a spray of colder water in the region of the valves. The quantity of water was increased as compared with that of the AS5.

This cylinder was found to withstand the greater power specified and, even with the power increased from 2,800 to 3,000 horsepower, no difficulties were found except small water losses that were easily recovered by soldering.

Pistons.- The piston of the AS5 was finned to permit easier transfer of the heat from the piston head to the fuel but it was cast in sand and developed cracks at 1,000 horsepower. On the AS6 the finning was retained but forged alloys were used. The weight of this piston was appreciably reduced (1.160kg (2.56 lb)) and the cooling surface of the fins measured 248 cm² (38.44 sq in.). This piston could support a mean effective pressure of 17 kg/cm² without giving the least trouble. The alloy initially used was duralumin which was then advantageously replaced by hiduminium RR 59.

Valves.- The exhaust valves, considered the weak point of the modern internal-combustion engine, did not fail to receive particular attention in the design shop and in preliminary tests received still further important modifications intended, together with the circulation of water at the cylinder head already described, to improve cooling to a maximum. In order to conduct the heat better from the cap to the stem within which was maintained an active circulation of water, a light, well conducting aluminum rod was incorporated in the stem.

Since the sodium valves at that time were something new and not sufficiently experimented with, it was considered best not to introduce them in order not to encounter unexpected difficulties. Some brief tests showed in fact that the sodium tended to solidify along the upper part of the stem which, being at a low temperature prevented, through the energetic cooling, the sodium from melting and hence made its presence in the valve stem useless.

Brief mention will also be made of the phenomenon of of valve-seat burning, which gave cause for much concern because it was encountered in the last stage of the test-

ing when the engine had already passed the official acceptance tests. These burns, restricted to small regions of the valves, were believed at first to be due to cooling deficiency and radical means were already taken to remedy the defect, such as the relining of the cylinders to put in valves of reduced dimensions, when it was discovered that the burns were due to a phenomenon of a purely mechanical nature. It was noted that all the burned valves presented signs of having undergone a greater travel than was imposed on the valves by the cam, since the spring supporting dish appeared to have touched the valve guide. This was an indication of a displacement of the valve gear because of a vibration phenomenon. When the springs were redesigned, the burns disappeared. The latter were evidently due to the stamping and consequent deterioration of the valve seat which struck against the cylindrical seat with greater intensity than that allowed for.

Connecting Rods.- The connecting rod was of the articulated type common to all Fiat engines and it was not considered necessary to make it any stronger than that of the AS5 so as not to overload the bearings with excessive weights of the rotating and reciprocating masses. It was therefore redesigned to avoid such troubles as those of the AS5, where the white bearing metal was cast directly on the connecting rods and tended to crack and loosen with great ease. On the AS6 connecting rod the bearing was bushed with lead bronze. The frame, due to the great resistance of this material to repeated stresses, was very much reduced in thickness (0.85 mm (0.0335 in.)). Because of the rigidity of the connecting-rod ends, there were no difficulties of any kind, even when white metal was used, as will be seen below.

The steel used in construction of the connecting rods was initially nickel chrome molybdenum with 140 kilograms of resistance to fracture rather than ordinary nickel chrome of 110 kilograms resistance employed for the AS5. During a certain period of the final testing, serious fractures were found. The phenomena that accompanied these fractures, such as deformation of the fork of the secondary connected rod, crushing of their liners, formation of X-shape wrinkles on the connecting-rod stem, showed that the fractures resulted from overloading in compression. Since all these fractures occurred simultaneously with backfiring in the engine, it was concluded that they were caused by very high explosion pressures due to backfire. It was supposed that the flame propagated along the feed pipe

through the still-open valves at the beginning of the compression stroke could ignite the mixture during that stroke. As is readily computed, the final pressure in such case may reach very high values, and the cracks could thus be explained. The phenomenon, however has remained obscure. Since these cracks revealed a weak point of the engine and because of the bad experience with this type of steel for the crankshaft of series production engines and the propeller shaft of the AS6, it was decided to return to the old steel of 110 kilograms, suitably reinforcing the I section of the connecting rod. After this modification, little backfire occurred and no trouble was found with the connecting rods.

Bearings.- The main bearings and those of the connecting rod were designed of lead bronze, which, in 1930, constituted the latest finding of technology. Since, however, several cases of melting of these bearings were found and because of their great sensitiveness to low lubrication, rather than continue to experiment with greater quantities of carefully filtered oil with all the devices that experience had indicated for obtaining good results with this type of bearing metal, it was decided, on account of the lack of time to return to the old material, that is, to white bearing metal. The latter, notwithstanding the very high values of the loads, gave good performance. As an advantage of this return to the old, there was an improvement in the oil consumption of the engine due to the smaller clearances required of the white metal as compared with the red and hence the smaller projection of oil into the cylinder.

Engine base.- On account of the great rigidity necessary in this particular type of very long, narrow engine, it was necessary to design the base very robust as has been stated. The adoption of an aluminum alloy would have led to a non-admissible weight, so that it was necessary to use magnesium which had already given rise to difficulties in the case of the AS5. Also in the case of the AS6, the cracks in the supports of the mountings were repeated. From the study of the fracture surface, the start of the fatigue fracture was determined to be in the region where the bolts of the supporting housing terminated. By suitably reinforcing this region with the addition of ties and varying the length of the bolts so as to increase the distance between the points of concentration of the forces, the fractures were eliminated.

Feed system.- As mentioned in the description of the engine, the most distinguishing feature of the AS6 was the adoption of a single supercharger to feed two independent engines and, for reasons of compactness, as has been explained, the carburetor was located ahead of the supercharger. The latter received the fuel-air mixture and delivered it under pressure to the two engines. The fuel pipes were of an unusual length, the distances between the first and last cylinders being widely different (0.90 mm (0.0354 in.) between the axes of the first cylinders and the supercharger outlet compared to 2,250 mm (88.6 in.) between the axes of the last cylinders and the supercharger outlet). Moreover, since the two groups of 12 cylinders constituted two independent systems, there was a phase displacement of the intake of one system with respect to the other that might have led to serious difficulties even when the problem was simplified by having the pipes under pressure rather than vacuum as in the usual engines provided with superchargers. Since the supercharger, because of the heat generated during compression and the mechanical mixing action produced by the impeller, tended to render the mixture more uniform, favoring vaporization, it was unavoidable that condensation of the fuel should occur aft of the supercharger at the various speeds and particularly in idling and this condensation, being irregularly distributed at the cylinders, would have led to serious lack of uniformity of distribution of the mixture to the various cylinders.

In order to avoid these difficulties inherent in the design itself and because of the particular application requirements, various types of intake pipes were designed and tested. Initially the supercharger had two outlets to which were connected two pipes parallel to the rows of cylinders. With this system, however, there was a very divergent fuel distribution for the two cylinder rows. There was then tried a single pipe located in the V of the cylinders and from which lateral branches passed out, feeding first three then two cylinders. The form and section of this pipe were changed several times until finally a circular section was chosen with the pipe located above the cylinders in such a manner that no condensation could be formed and then be unequally distributed to the various cylinders. It is to be observed that this shape of pipe which, in practical tests proved to be the best from the point of view of the uniformity of the fuel distribution, presented the disadvantage of a great volume of gas. The dangerous effects of possible backfiring were therefore increased.

This brings us to the difficulty which gave the greatest trouble during the entire final testing and during the first flights and which required the most time to eliminate, if not entirely, at least to a sufficient extent that no serious consequences were produced.

The underlying reason for this tendency to backfire has remained obscure, but it must have been due to defective combustion produced by various causes, which were investigated and successively eliminated. The first was defective ignition and timing. As has been said, the engine was initially designed with battery and dynamo ignition. The spark generators, four in number, were compactly located at the four ends of the cam boxes where they were driven by the camshaft through suitable couplings. Trouble was found in frequent breaks of these couplings and breaks in the brushes of the generators. This was a first indication of abnormal operation. It was decided to make a better study of the motion of these parts in order to be able to explain the fractures and on observing the motion of the rotating brushes with the stroboscope it was found that at certain speeds of the engine the brushes were subjected to torsional vibrations of such large amplitude that the spark occurred at a different contact from that intended, causing a shift of the ignition out of phase and hence backfire. Because of the limitation of time and other troubles found with the dynamo it was decided to return to the solution of ignition by magneto already tested. The front of the engine and the supercharger housing were thus redesigned to mount the magnetos. With this solution, the total weight of the ignition system was reduced by 10 kilograms.

Having eliminated the ignition disturbances, the backfire diminished in frequency but persisted at the high speeds. The cause was found in the carburation, which tended to become lean at the high speeds. By suitably enriching the mixture at the high speeds, it was found to be too rich and unacceptable at low speeds. The carburetor was therefore modified by introducing an automatic rich-mixture control which operated only at high speeds. There was thus anticipated the double feed carburetor whose use is so widespread on all modern airplane engines. By this expedient, the operation of the engine was greatly improved.

Backfire caused by dirty spark plugs or by autoignition still persisted, however. The greatest care was

taken in testing the spark plugs. It was necessary, before seeking a suitable type, to eliminate the dirtying of the spark plugs. The oil passage in the cylinders was therefore reduced by suitable combinations of oil wiper rings and at the same time an improvement was obtained in the condensation of the gasoline in the intake tubes, which, on entering the cylinders dirtied the spark plugs. In order to remedy the injurious effects which the backfire produced by igniting such a large volume of gas as was contained in the feed pipe alone, suitable safety valves were finally arranged at various points of the pipe and of the supercharger. With all these devices, the operation on the test stand was finally satisfactory and the initial acceptance tests of one hour's operation of the engine without blower air were satisfactory.

The backfire problem proved serious when the first flight tests were made. The spark plugs chosen, being of porcelain, were fractured in flight and hence gave rise to irregular ignition and difficulties in the water circulation led to autoignition at the spark plugs. These two irregularities produced backfire and to these were added defects in the fuel feed due to the automatic regulating pumps which produced the same difficulty. Having eliminated these disturbances in successive flights, the backfire still persisted in some cases. This led to the suspicion that the flight wind by acting on an air intake of insufficient length created vortices at the carburetor entrance, producing sudden variations in the fuel level in the tank and hence dangerous leaning of the mixture. It was then decided, since participation in the Schneider Cup race was no longer possible, to bring the engine to the stand again to repeat the tests with the relative flight wind acting on the engine.

Before constructing the imposing test installation already described, it was proved by a simple test that the suspicions were founded. By directing a jet of air against the carburetor in certain positions, it was possible to produce backfire instantly.

Since it was seen that the cause of the backfire found in flight was excessive leaning of the mixture produced by the effect of the wind at the intake of the carburetor, it was decided to apply to the engine a dynamic air intake which should furnish the carburetor with calm, non-turbulent air. A pipe of gradually increasing cross section was therefore mounted horizontally above the en-

engine and this acted as a diffuser, transforming the kinetic energy of the wind into pressure. Since the velocities varied gradually from the conditions at take-off to those at full throttle, level flight, the dynamic pressure of the wind also underwent large variations. It was necessary therefore to study from the beginning the regulation at the carburetor with the object of rendering it automatic at the various velocities. For this purpose, at a suitable section of the air intake, a multiorifice pitot tube was mounted, each orifice of which conducted, by means of a suitable tube, the ambient pressure to the different compartments of the carburetor, namely, the float chamber, the minimum adjustment, the fuel pumps, etc.

There were then carried out the tests with the apparatus already described which reproduced the relative flight wind, suitably concentrating it at the air intake of the engine. The velocity was suitably varied and by means of transparent, level tubes the variations in the level of the fuel contained in the carburetor float chamber were observed. In order to reproduce better the operating conditions of the engine, the entire fuel circulating apparatus as it actually existed on the engine was transported to the test chamber and used in the tests. The carburetion could thus be perfectly regulated, rendering it non-sensitive to variations in velocity. A definite remedy was thus found against the chronic backfiring and in the subsequent flights the trouble was eliminated.

The application of the dynamic air intake which utilized the effect of the wind resulted in an increase of the supercharge of the engine and hence in an increase in the power which the engine could safely develop. Thus, while the power of the engine before the application of the dynamic intake was about 2,400 horsepower, it was later increased to 2,800 horsepower and in the engine intended for the race, with a final increase of the rotational speed from 3,200 to 3,300 revolutions per minute, and with a several-stage supercharger, 3,000 horsepower were obtained at the brake.

Supercharger.- The supercharger, as has already been said, was first separately provided, being geared to give the speeds of 17,000, 19,000, and 21,000 revolutions per minute. During these tests, the final form of the diffuser was chosen and it was found necessary to modify the support of the impeller shaft, substituting for the bushings, ball and roller bearings. It was not possible, how-

ever, to eliminate the defects of the coupling joint at the engine, which appeared only when the supercharger was installed on the engine. This member underwent various modifications and finally a passable solution was found in the use of a friction clutch gradually and automatically engaging by the action of the centrifugal force on a row of spheres which exerted a load on a pack of disks. There was always found a rapid wear of the disks and only by the use of a special combination of cast and steel disks was the wear held down to the required limits between overhauls. Trouble was also found with fractures of the aluminum impeller which were remedied by the suitable reinforcement of the impeller blades through the use of hiduminium. Moreover, the entire supercharger body, which was of magnesium, was reinforced at various times to put it in a condition to resist the backfire and was provided with safety valves.

The leakage of oil in the supercharger gave much trouble on account of the dirtying of the spark plugs and thus causing backfiring. After several experiments of various labyrinths placed between the shaft fan and gear box, it was finally eliminated by the artifice of placing the labyrinth under atmospheric pressure. The local vacuum which sucked oil into the supercharger was thus eliminated.

Propeller reducing gear.- The only trouble found was fracture of the shafts at the multiple fixing grooves of the gears. It was remedied by eliminating the force concentration on the teeth of the shaft by having them longer than those of the gear and also by changing the type of steel.

Fuel.- As already mentioned, the solution adopted for the AS6 provided for a relatively low supercharge and this made it unnecessary to use mixtures of high latent heat of vaporization. For the first time, the use of tetraethyl lead as an antidetonant was introduced. Two mixtures were used, the first, denoted as a Pratts mixture of gasoline base with benzene and lead, served for the first endurance test. This mixture, characterized by a low specific weight and high calorific value, possessed a low latent heat, so that its use led to a rather high temperature of the compressed mixture and hence to a low loss in power of about 4 percent, compared to the mixture with alcohol. The fuel consumption, however, improved about 8 percent, finally reaching the extremely low value of 240 g/hp-hr (0.529 lb). It had a great volatility and hence good fuel distribution

but excessive ice formation on the carburetor valves. After many tests, the following mixture was finally decided upon:

Stanavo benzine - - - 55 percent by volume

Ethyl alcohol - - - - 23 percent by volume

Benzene - - - - - - 22 percent by volume

100 + 1.5 percent tetraethyl lead

Specific weight - - - - 0.776

Calorific value - - - - 9,387 cal/kg

Latent heat - - - - - - 115 cal/kg

This did not differ from the mixture used for the AS5 engine, except for the addition of tetraethyl lead. With the above mixture, the fuel consumption was varied between 260 and 270 grams (0.573 and 0.595 lb), ice formation on the carburetor was prevented, and powers of the order of 60 hp/liter could be obtained without detonation. The temperature of the compressed air from the supercharger never exceeded the value of 60°.

RESULTS

In the first phase of the bench tests conducted without relative wind, the first one-hour test was conducted April 20, 1931. The engine developed a power of only 2,200 horsepower with the Pratts mixture. One month later the one-hour acceptance test was conducted on another engine with the development of 2,400 horsepower.

In the second phase of the tests, when the dynamic intake was added to the engine and tests were conducted with variable wind at the mouth of the carburetor, there was obtained the curve shown in figure 15. It is seen that the maximum power attainable at 3,200 revolutions per minute with the maximum wind of 700 km/h (435 mph) was 2,850 horsepower.

The final tests were made according to a well predetermined curve that took into account the speed, throttle

opening, and wind velocity under the condition of the 3-kilometer race. The acceptance test consisted in repeating five times the curve obtained, and lasted in all 35 minutes. Two types of engines were used: those designated for the Bleriot Cup, which developed 2,400 to 2,500 horsepower and those for the records, which developed 2,800 to 2,850 horsepower.

One of these engines, speeded up to 3,300 revolutions per minute and with a supercharger at 19,000 revolutions per minute, attained a power above 3,000 horsepower. A fact worth mentioning and which shows the notable endurance of this engine is that in one test it ran 64 hours, 7-1/2 of which were at full power of 2,400 horsepower and 3 at 2,850 horsepower.

The engines were mounted on the M.C. 72 and entrusted to the pilots of the Scuola di Alta Velocita of Desenzano commanded by General M. Bernasconi.

With the 2,400 horsepower engines, the following records were won:

Absolute speed record for 3 kilometers at the speed of 682 km/h (424 mph), by Franco Agello, April 1933.

Absolute speed record for 100 kilometers at 629.37 km/h (391 mph), by Guglielmo Cassinelli, Oct. 8, 1933.

Bleriot Cup for one-half hour flight at 619.274 km/h (385 mph), by Pietro Scapinelli, Oct. 21, 1933.

The speed record for 3 kilometers, won by Franco Agello, was surpassed by the same pilot by raising it to 709.209 km/h (441 mph) on Oct. 23, 1934, with an engine capable of 3,000 horsepower at 3,300 revolutions per minute but not used to full capacity.

Translation by S. Reiss,
National Advisory Committee
for Aeronautics.

TABLE I
Principal Characteristics of Fiat Race Engines

Type	Power (hp)	Revolutions per minute (rpm)	Bore and stroke	Capacity (liters)	Compression ratio	Mean effective pressure (kg/cm ²)	Mean effective pressure (supercharger) (kg/cm ²)
AS2	800	2,300	140 x 170	31.34	6	10	-
AS3	1,000	2,400	145 x 175	35.16	6.7	10.6	-
AS5	1,000	3,200	138 x 140	25.1	8	11.3	-
AS6 (Bleriot Cup)	2,500	3,200	138 x 140	50.2	7	14	15
AS6 (Speed record)	3,000	3,300	138 x 140	50.2	7	16.25	17.38

Type	Supercharge pressure (meters of water)	Fuel consumption (g/hp-hr)	Oil consumption (g/hp-hr)	Weight (kg)	Weight per hp	Horsepower per liter	Frontal area (hp/dm ²)
AS2	-	230	15	388	0.485	25.52	17.36
AS3	-	235	10	422	.422	28.44	21.85
AS5	-	220	15	345	.345	40	25.06
AS6 (Bleriot Cup)	4.30	260	15	930	.372	49.8	53.64
AS6 (Speed record)	8	270	15	930	.310	59.7	64.3

TABLE II
 Pressure x Velocity
 (kg/cm²/m/sec)

Bearing	Engine types				
	A3 ORA	AS5	AS6		
			Bleriot Cup	Speed record	
Connecting rod	794	1,070	1,123	1,465	
Main {	External	582	955	975	1,075
	Intermediate	612	1,010	1,030	1,180
	Central	883	1,350	1,490	1,690

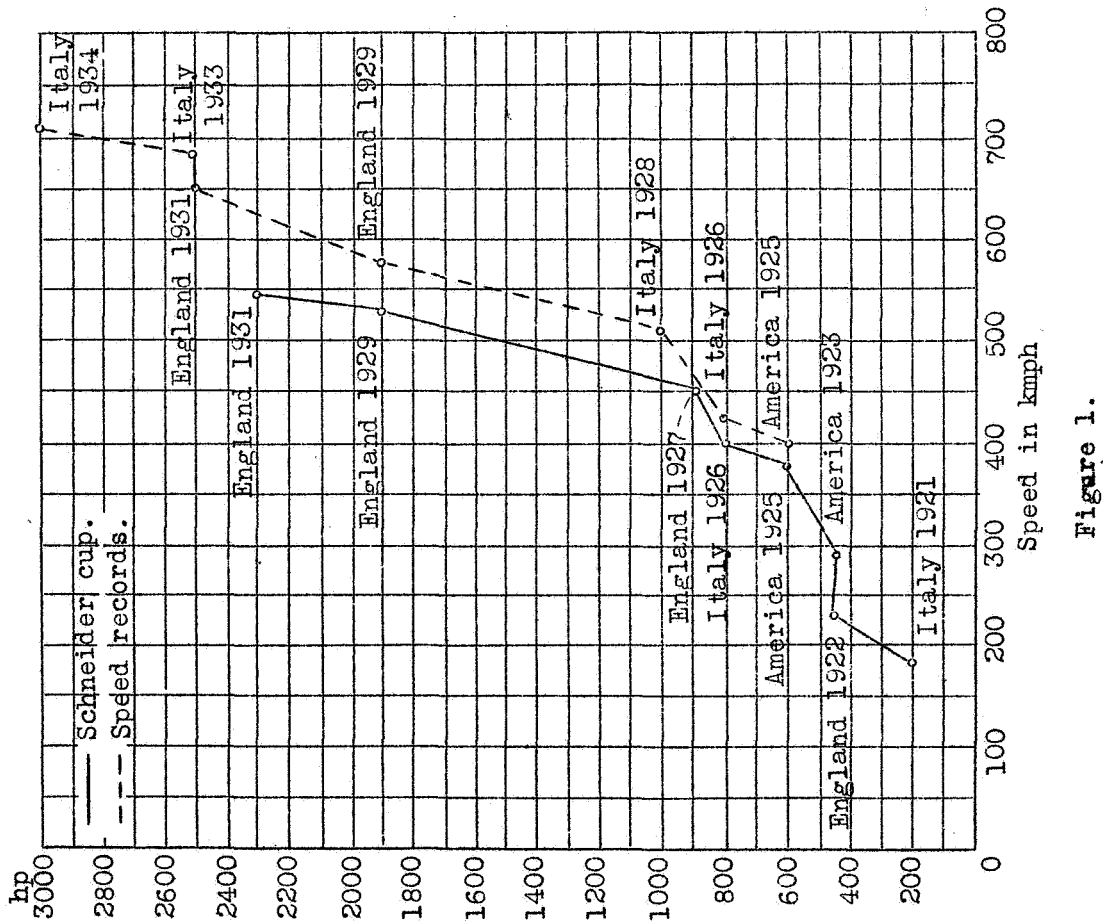
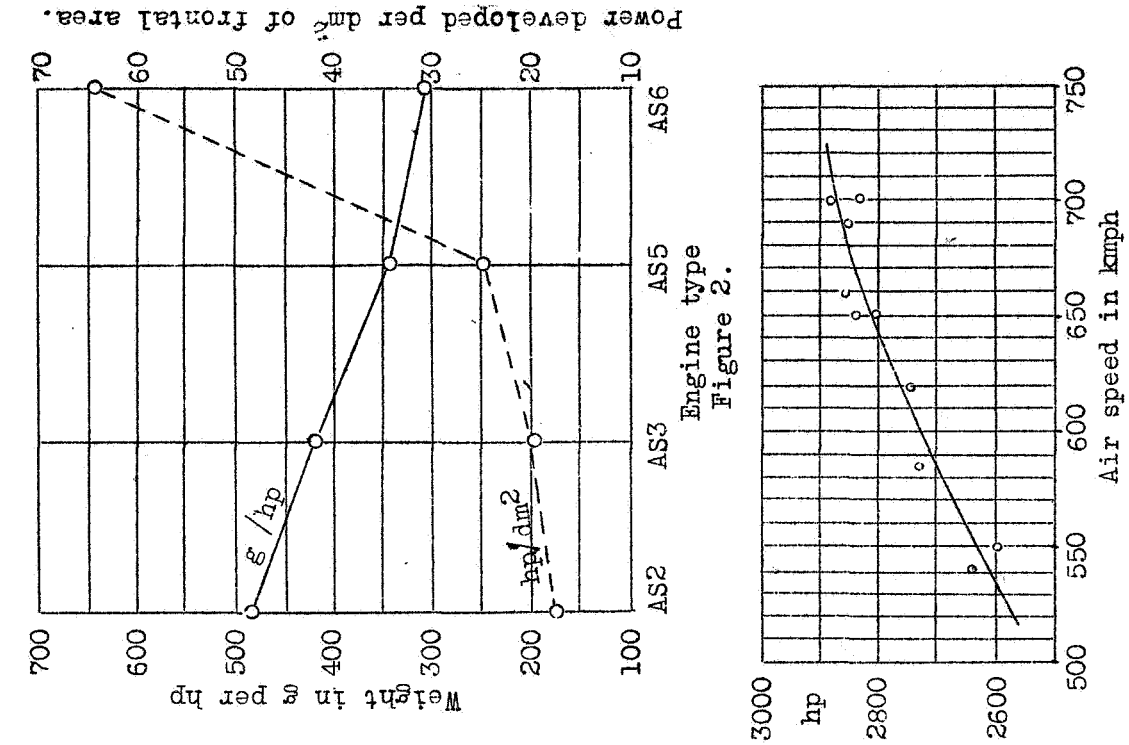

Figure 15.-Variation of power with air speed at 3200 rpm. Fiat engine AS6.

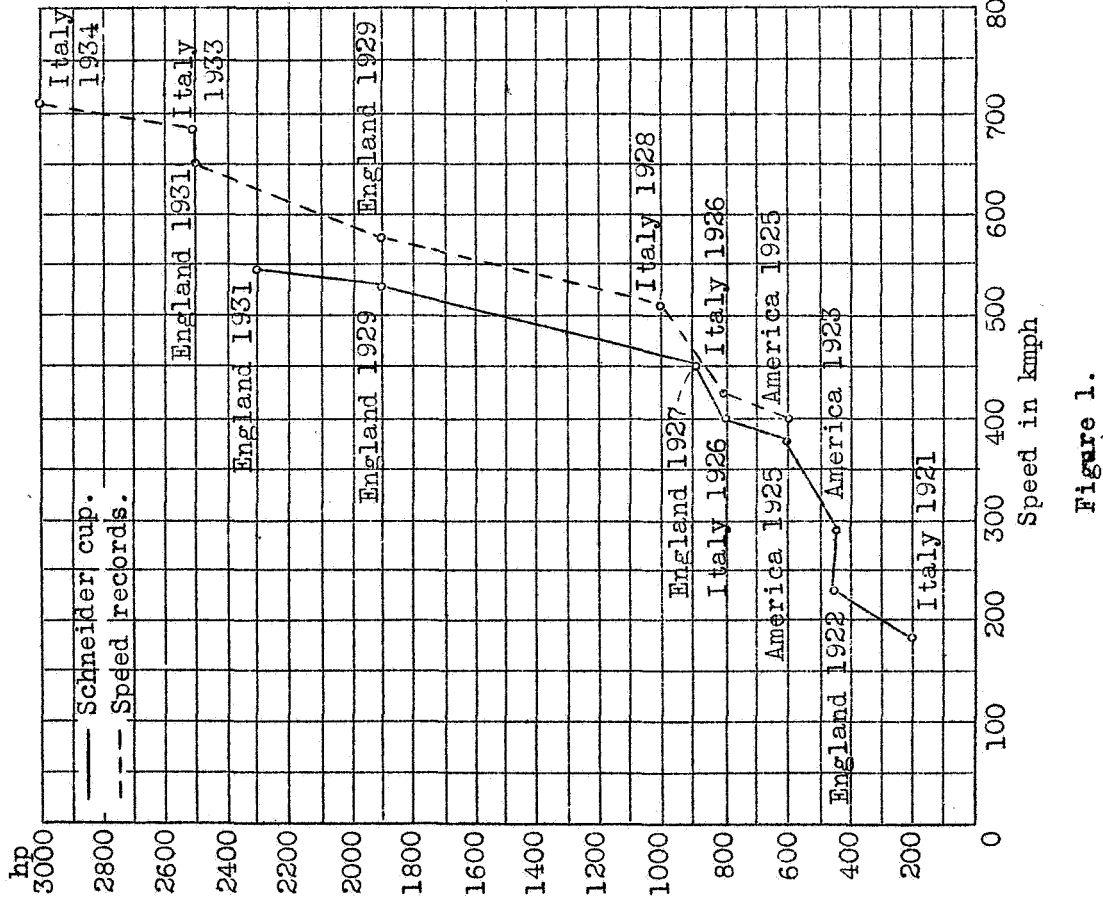

Figure 1.

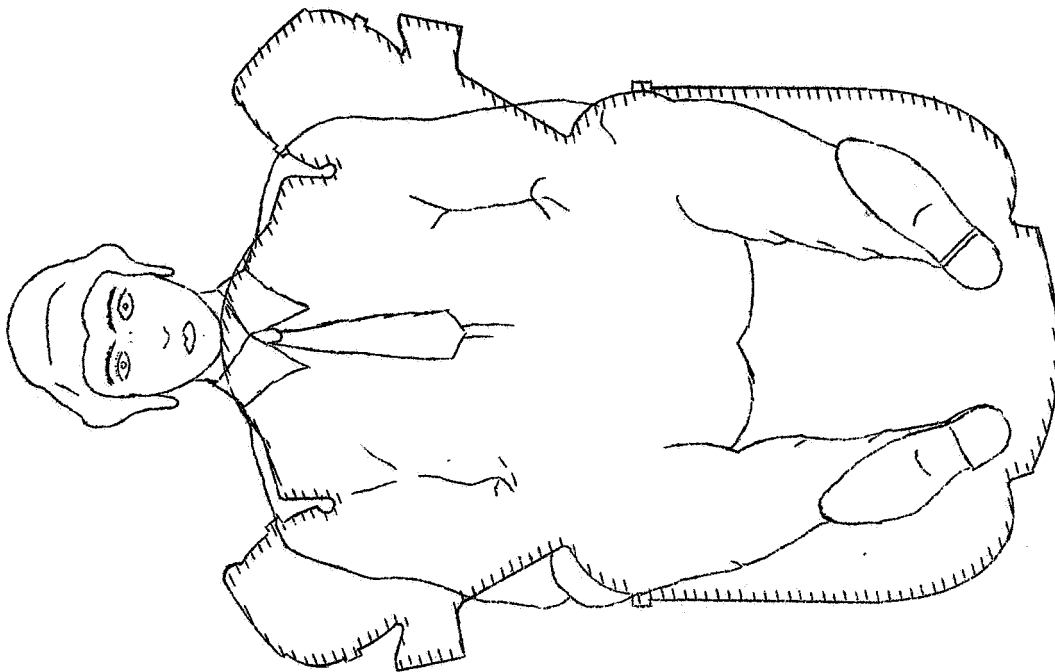

Figure 4.

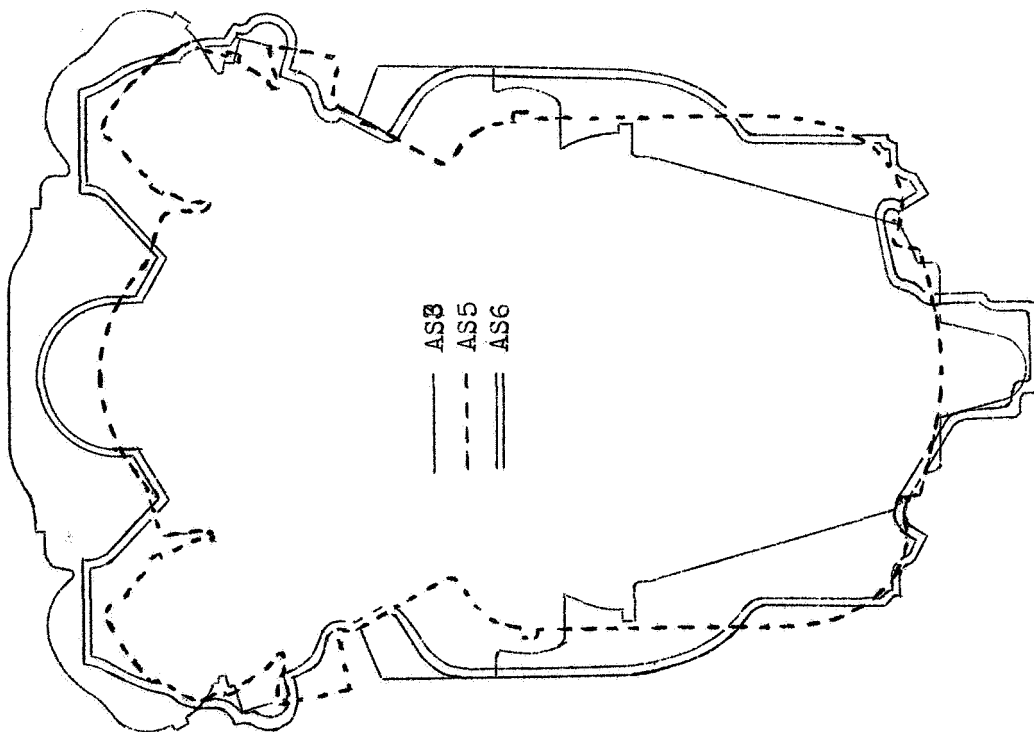

Figure 3.

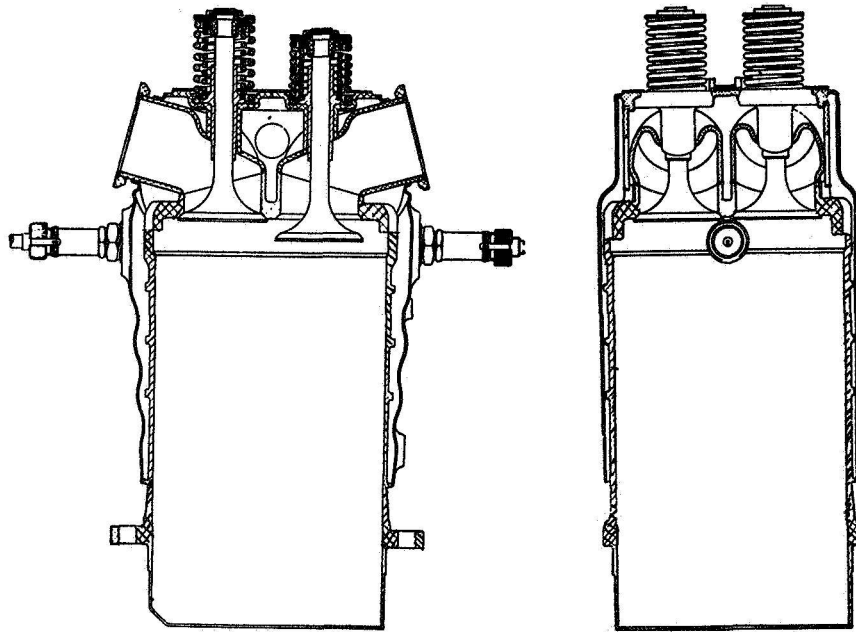

Figure 5.-

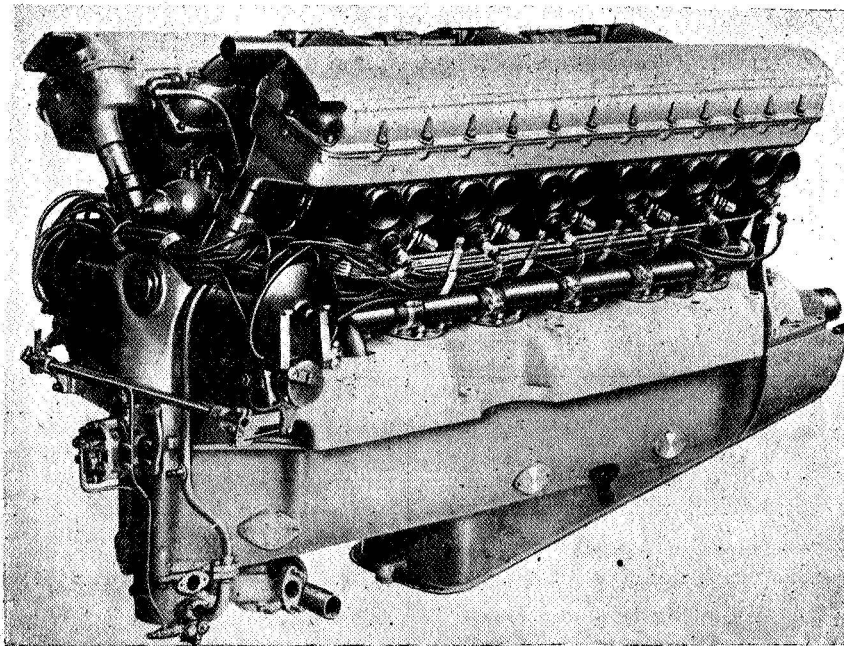

Figure 6.- Fiat AS 5 engine.

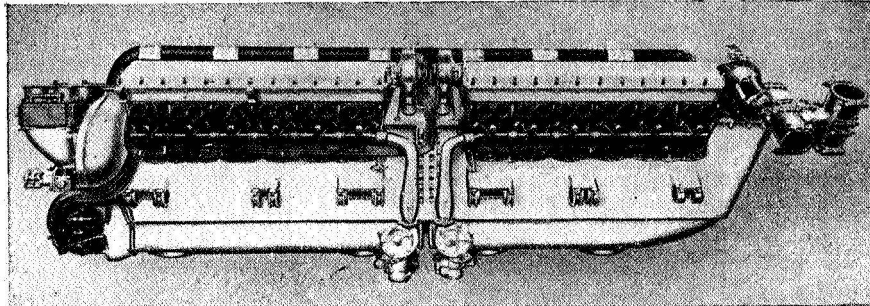

Figure 7.- Flat AS 6 engine.

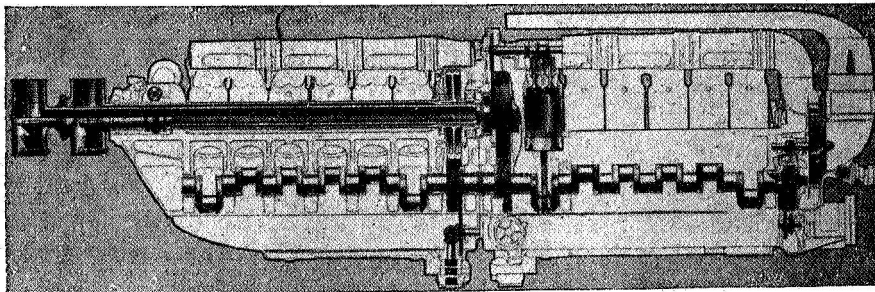

Figure 8.- Section of AS 6 engine.

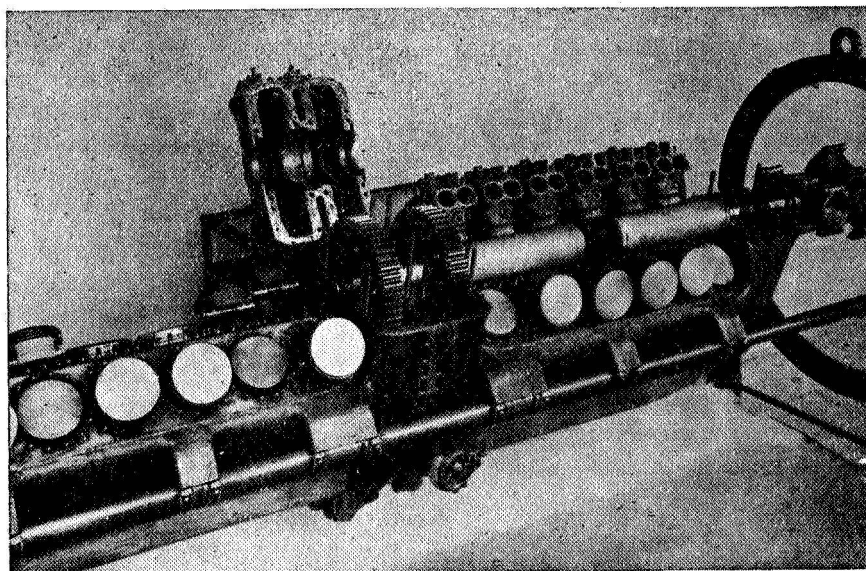

Figure 9.- AS 6 engine disassembled

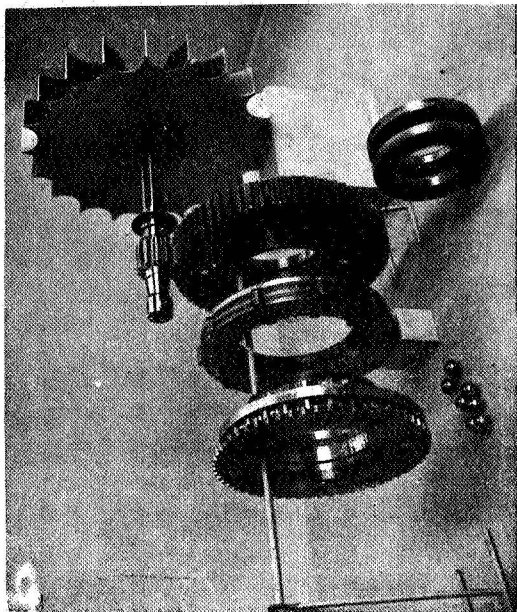

Figure 10.- Supercharger for AS 6 engine.

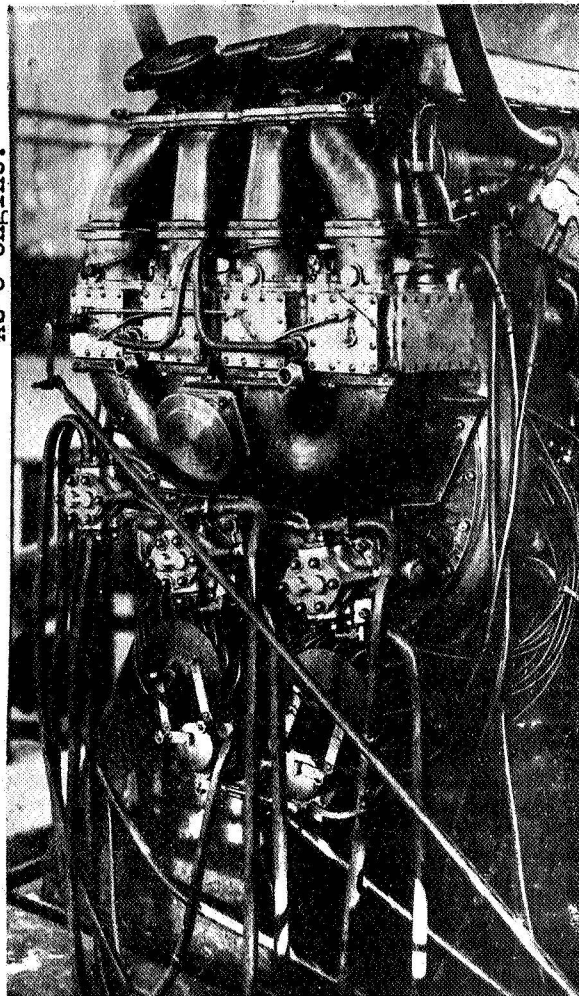

Figure 12.- Carburetors and fuel pumps. AS 6 engine.

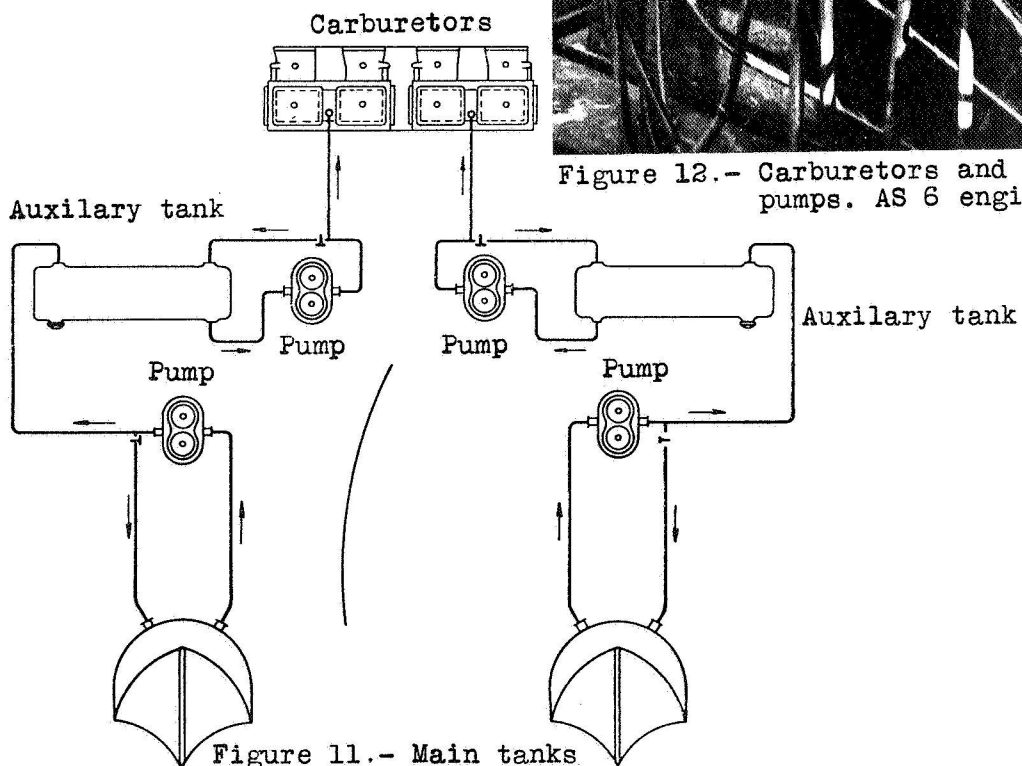

Figure 11.- Main tanks in the floats.

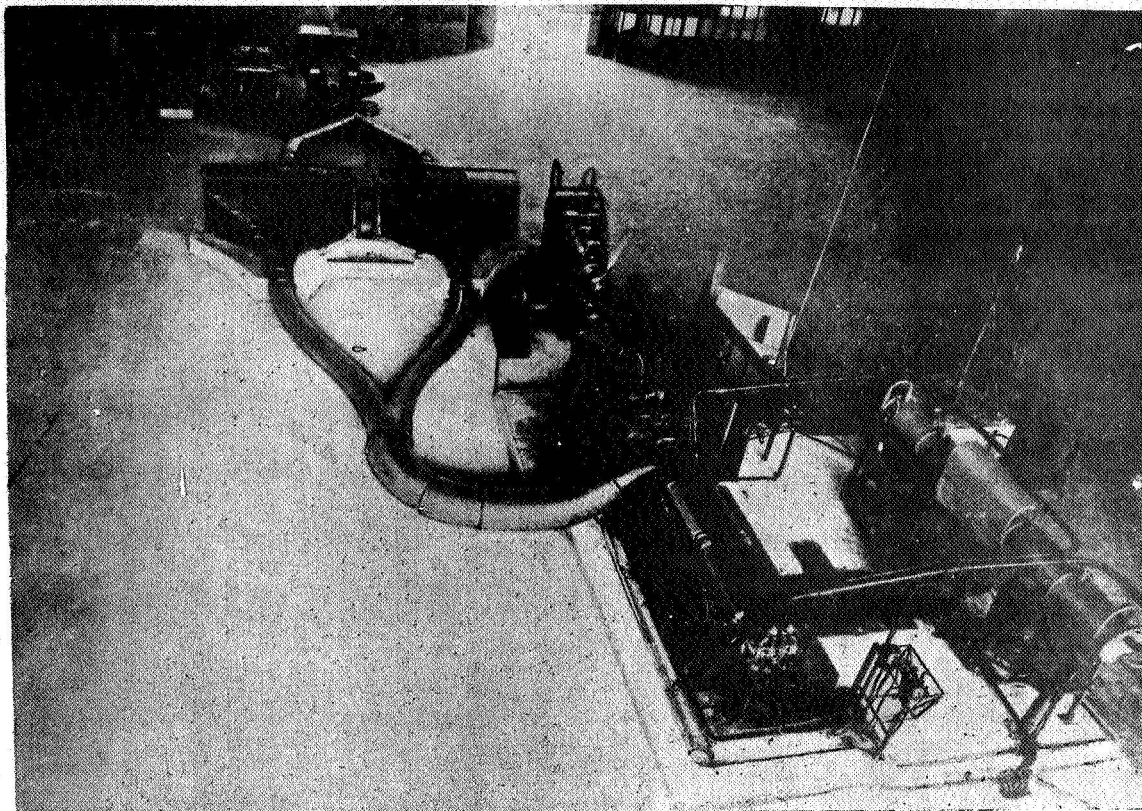

Figure 13.- Bench test with blower.

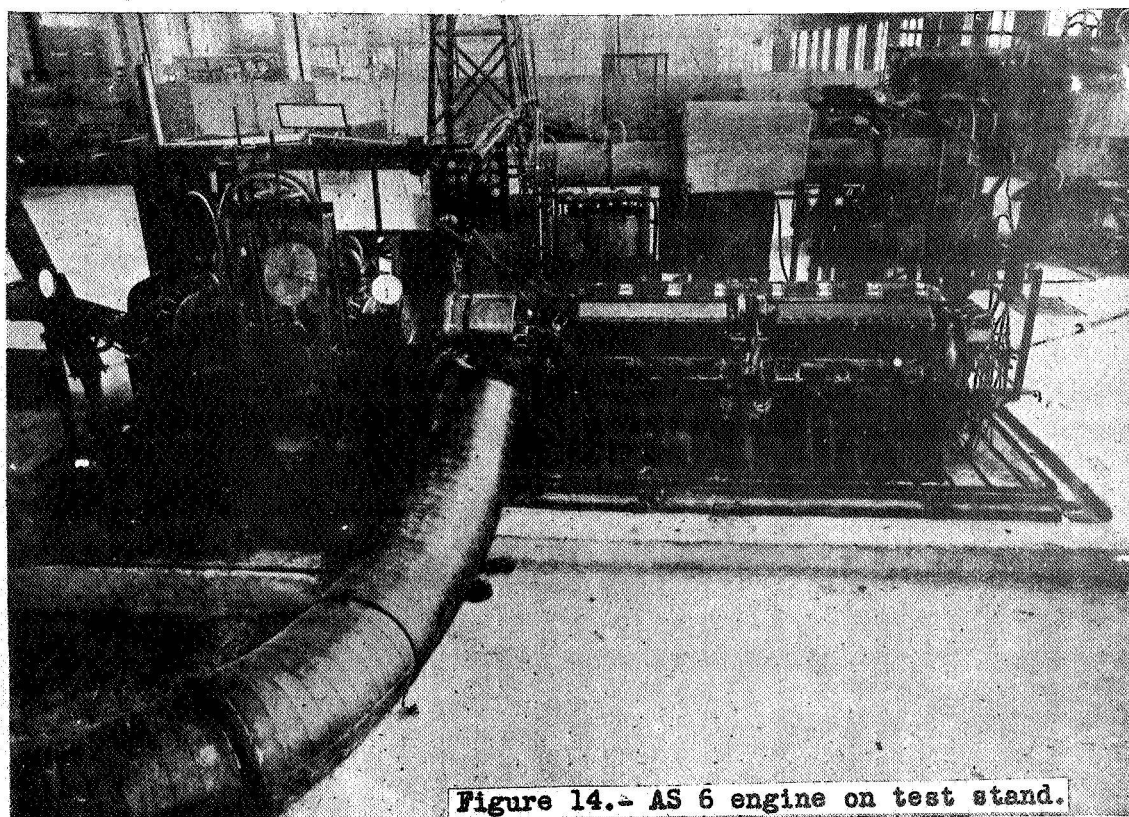

Figure 14.- AS 6 engine on test stand.