

NATIONAL ADVISORY COMMITTEE FOR AERONAUTICS

# WARTIME REPORT

ORIGINALLY ISSUED

October 1944 as  
Memorandum Report L4J19

RÉSUMÉ OF NACA STABILITY AND CONTROL TESTS  
OF THE BELL P-63 SERIES AIRPLANE

By Harold I. Johnson

Langley Memorial Aeronautical Laboratory  
Langley Field, Va.

JPL LIBRARY  
CALIFORNIA INSTITUTE OF TECHNOLOGY



WASHINGTON

NACA WARTIME REPORTS are reprints of papers originally issued to provide rapid distribution of advance research results to an authorized group requiring them for the war effort. They were previously held under a security status but are now unclassified. Some of these reports were not technically edited. All have been reproduced without change in order to expedite general distribution.

NATIONAL ADVISORY COMMITTEE FOR AERONAUTICS

MEMORANDUM REPORT

for the

Army Air Forces

RÉSUMÉ OF NACA STABILITY AND CONTROL TESTS  
OF THE BELL P-63 SERIES AIRPLANE

By Harold I. Johnson

I N T R O D U C T I O N

A résumé report on stability and control tests of Bell P-63 series airplanes, which have been conducted at the Langley Memorial Aeronautical Laboratory of the National Advisory Committee for Aeronautics, has been prepared and is presented herein. The purpose of this report is to describe briefly and to summarize NACA wind-tunnel tests conducted on models of the P-63 airplane and NACA flight tests conducted with two P-63A-1 airplanes up to the present time. In general, tests having an insignificant bearing on the possible development of the airplane are entirely omitted. Details of testing technique are also either omitted or treated only briefly. In cases where comparable tests were made in the wind tunnel and in flight, only the flight results are discussed. This is done because the wind-tunnel stability and control tests were entirely of a qualitative nature; the models used were of low scale and the tunnel velocities were also low. Major emphasis is laid on conclusions that may be drawn from the tests and on the opinions of NACA personnel with regard to the merit of the airplane and the merit of possible changes which may increase the value of the airplane from the stability and control standpoint. The remainder of this section of the report is devoted to a brief chronological outline of the wind-tunnel and flight stability and control investigations which have thus far been conducted on P-63 series airplanes by the NACA. At the time of this writing flight tests are still in progress.

Wind-tunnel tests of P-63 series airplane models were started in 1941 when a section model of the

XP-63 horizontal tail was tested in the 4- by 6-foot closed-throat vertical wind tunnel. Measurements were made of horizontal tail plane, elevator and tab effectiveness, drag, and elevator hinge moments. Three different elevator nose shapes were tested and of these the one giving the best over-all characteristics was determined.

Spin tests were made with a  $\frac{1}{15}$ -scale model of the XP-63 and P-63A-1 airplanes in the 20-foot free-spinning tunnel in 1942. These tests were made to predict the ability of the full-scale airplane to recover from fully developed spins. The effects on spin recovery of sequence of control motion, airplane loading, and exterior configuration were investigated. In January of 1944, further predictions were made of the spin characteristics of heavily loaded P-63 airplanes with gross weights ranging from 8,600 to 12,600 pounds. Results of these predictions, as well as the earlier results, will be discussed farther on in this report since no full-scale flight tests were made by the NACA to investigate the spin characteristics of the airplane.

A qualitative determination of the general stability and control characteristics of a  $\frac{1}{10}$ -scale powered dynamic model of the XP-63 airplane was made in the Langley free-flight tunnel in the early part of 1943. Because full-scale flight tests of a quantitative nature have since been made, covering all of the important items investigated in the free-flight tunnel, the free-flight tunnel tests will not be further discussed in this report.

Flight tests of P-63 series airplanes at the NACA were begun in the latter part of 1943 when a determination of the longitudinal stability and control characteristics of one of the first P-63A-1 airplanes built (AAF No. 42-68861) was made. In conjunction with these initial longitudinal-stability tests a few data on the lateral control characteristics of the airplane were obtained.

Beginning in the first part of 1944 and continuing until the present time, an extensive flight program of testing and development has been carried on with another P-63A-1 airplane (AAF No. 42-6889) at the NACA. The primary purpose of this program is to improve the

longitudinal stability and control characteristics but some effort has also been directed toward improving the directional stability and control characteristics of the airplane. Up to the present time, tests in this program have been conducted with four different sets of elevators, two different horizontal stabilizers, and two different vertical tail surfaces. Future tests are expected to be made with another set of elevators, a dorsal fin, and a ventral fin. The major part of this report is based on the test work covered in this most recent flight test program.

## DESCRIPTION OF AIRPLANE AND MODIFICATIONS

Dimensional characteristics of first-production P-63A-1 airplanes and of the various horizontal- and vertical-tail modifications tested in flight are given in the appendix. The following figures contain descriptive material which is often referred to in later discussions of tests made with the airplane at the NACA.

Figure 1 contains five reproduced pictures of an early model P-63A-1 airplane. Figure 2 is a three-view drawing of the same airplane. Initial flight tests and nearly all wind-tunnel model tests were conducted with this version of the P-63 series airplane. Aileron dimensional characteristics are graphically portrayed in figure 3. The various horizontal-tail plan forms covered in flight tests of longitudinal stability are shown in figure 4. Figure 5 shows cross-sectional outlines of the different elevators tested in flight. Figure 6 describes the two different vertical tail surfaces used in the flight work done to improve the directional stability and control characteristics of the airplane. Finally, figure 7 shows photographs of the modified P-63A-1 airplane as it is presently being tested. The airplane represented by figure 7 differs from that shown by figure 1 in that it is equipped with larger horizontal and vertical tail surfaces and has a dorsal fin.



## D I S C U S S I O N

## SPIN CHARACTERISTICS

All spin tests were conducted with a  $\frac{1}{15}$ -scale dynamically similar model of the P-63 airplane in the Langley 20-foot free-spinning vertical tunnel.

At the outset of spinning tests it was decided that the spin characteristics of the airplane should be made satisfactory in terms of the average pilot. For this reason a criterion was established which provided that the spin-tunnel model should be able to recover from fully developed spins in two turns or less after the rudder had been moved two-thirds full deflection against the spin with the ailerons set either one-third with or one-third full deflection against the spin and with the elevator set two-thirds full-up.

The original XP-63 model, ballasted to represent the airplane with a gross weight of 7447 pounds, did not meet the recovery criterion. The model spun flat and recovery was too slow. Adding ventral fin and rudder area below the fuselage was beneficial but this modification was not adopted because the change in ground clearance angle accompanying it was deemed objectionable. Instead, the vertical tail was moved back 17 inches full scale and the fuselage was lengthened a corresponding amount. The recovery criterion was satisfied with this configuration for normal loading and the rearward shift in vertical-tail position was incorporated in the design of the full-scale airplane. After the vertical tail had been moved rearward the airplane configuration corresponded to that shown in figures 1 and 2. When the addition of wing guns and ammunition was simulated on the model (involving a weight increase of about 400 pounds full scale) recoveries were insufficiently rapid to satisfy the criterion if the ailerons were set one-third with the spin. Brief tests of antispin fillets - dorsal fins installed forward of the horizontal tail plane - indicated such a modification would aid recovery. As a result of these tests it was decided that the best all-round recovery technique would consist of holding the ailerons in neutral and completely reversing the rudder against the spin, followed by moving the elevator down.

Further spin-tunnel tests with the model reballasted to gross weights simulating the P-63A-1 airplane gave results similar to those described above. For a gross weight of 7704 pounds, full scale, without wing guns, recoveries were sufficiently rapid to meet the criterion. With the weight increased to 8076 pounds by adding wing guns the recoveries were unsatisfactory if the ailerons were held even partially with the spin. Holding ailerons against the spin expedited recovery. These tests indicated that the spin-recovery technique should vary according to the distribution of weight in a spanwise direction along the wings. When wing machine guns are installed and wing fuel tanks are full, deflecting the ailerons against the spin appears to be most beneficial to rapid recovery; when no wing guns are present and the fuel is almost entirely used from wing tanks, deflecting the ailerons with the spin appears conducive to quick recovery.

Recently an analysis was made to predict the spin characteristics of the P-63 in the interceptor and long-range fighter conditions, conditions in which the full-scale gross weights vary from 8,632 to 12,581 pounds. The effects of minor modifications to the wing tips and elevator, involving slight increases in area, were considered. It was predicted that recovery could not be made with sufficient ease to meet the criterion for any of the high gross weight conditions. It was predicted, however, that rapid recoveries could be made in any of these conditions if ailerons were deflected against the spin and the rudder was fully deflected against the spin followed by downward movement of the elevator.

Full-scale spin tests of P-63 airplanes made by the contractor agreed very well with results indicated by tests of P-63 models made at the NACA with the possible exception that recoveries from full-scale spins with wing guns installed appeared even more critical than the model tests had indicated. In this connection the contractor's flight tests showed that the exterior shape of the wing-gun fairings had a pronounced effect on spin-recovery characteristics. In contrast, model tests indicated that the direct aerodynamic effect of the exterior wing-gun installation on spin-recovery characteristics was negligible and that the adverse effect of installing wing guns was due to the increase in spanwise weight distribution accompanying the installation. If

the model tests are correct in this regard, no improvement in spin characteristics would be realized by simply installing the wing guns inside the wings instead of slinging them beneath the wings.

Summing up the P-63 spin characteristics on the basis of dynamic model tests, it appears that satisfactory recoveries from spins should be easily obtained with airplane gross weights under about 7700 pounds without wing guns installed. For gross weights ranging between 7,700 and 12,600 pounds and/or with wing guns installed, a precise sequence of corrective control action is required to effect rapid recovery from the spinning condition. Spin recoveries should be made less critical by adding a ventral fin and/or rudder area below the fuselage. The addition of horizontal dorsal fins should be beneficial to more rapid recovery as should the use of a taller vertical tail such as is shown in figure 6. Before leaving the subject of spinning it should be remarked that NACA flight tests indicate the stall-warning characteristics of the P-63 airplane are excellent so that inadvertent spinning would not ordinarily be encountered with this airplane. As the stall is approached, elevator buffeting and mild rolling motions occur which warn the pilot of an impending stall in sufficient time so that he can apply corrective control action before spinning has a chance to develop.

#### LATERAL CONTROL CHARACTERISTICS

Brief flight tests were made to determine the aileron characteristics of a first-production P-63A-1 airplane (AAF No. 42-68361).

The geometric characteristics of the P-63 ailerons are shown in figure 3 and additional dimensions are listed in the appendix.

The aileron characteristics were evaluated on the basis of the maximum rolling velocity and the stick force obtained by abruptly deflecting the ailerons predetermined amounts at indicated airspeeds of 120, 210, and 315 miles per hour while holding the rudder fixed in its straight-flight trim position. Indicated airspeed, as used throughout this report, corresponds to

the reading of a standard U. S. Army Air Force airspeed meter vented to correct impact and static pressures. As such it accounts for the compressibility error at sea level and hence expresses true airspeed at sea level under standard atmospheric conditions.

Figure 8 shows the data obtained in the test aileron rolls plotted as stick force and wing-tip helix angle  $pb/2V$  against estimated true change in total aileron angle. The parameter  $pb/2V$  is made up of symbols having the following definitions:

- $p$  rolling velocity, radians per second  
 $b/2$  wing semispan, feet  
 $V$  true airspeed, feet per second

Estimated true change in total aileron angle is used because only the position of the stick was measured in flight. The loss in aileron deflection due to the flexibility of the control system was estimated by measuring the amount of control-system stretch as a function of aileron stick force on the ground. Figure 9 shows the estimated rolling performance of the P-63 airplane as a function of indicated airspeed for 50 pounds aileron stick force.

On the basis of the brief flight tests to determine the aileron characteristics of the P-63 airplane the following conclusions are indicated:

The rolling performance of the P-63 airplane is generally satisfactory. The maximum rate of roll possible with full aileron deflection is exceeded by but few other current airplanes for which comparable data are available. Aileron effectiveness per unit area and per degree deflection is exceptionally high. The aileron stick forces are about normal for this type airplane. Because the stick forces, as a function of aileron deflection, are desirably linear and because only  $\pm 15^\circ$  of aileron travel are presently used, however, it appears that a further considerable increase in rolling performance could be obtained by making minor modifications to increase the aerodynamic balance of the ailerons and by increasing the permissible aileron deflection a few more degrees each way. If such

modifications are made, the P-63 airplane should exhibit exceptionally high rolling performance. In this connection, the question of the ability of the airplane to withstand the large aileron and vertical-tail aerodynamic loads associated with large aileron deflections at high speed should not be overlooked. Vertical-tail loads due to aileron action are discussed later in this report. Two other points appear to require attention in an evaluation of the P-63 ailerons.

First, on the airplane used to determine aileron characteristics (AAF No. 42-68861), the aileron control system was excessively flexible. For instance, a ground calibration indicated that only  $16\frac{1}{2}$  out of a possible  $30^\circ$  change in total aileron angle could be obtained with a stick force of 50 pounds. It is not known if this is a general condition in all P-63 airplanes but it is recommended that this condition be investigated and corrected if it is general. Flexibility, of course, needlessly penalizes the rolling ability of the airplane in the low and intermediate speed ranges. Second, the P-63 airplanes flight tested at the NACA were equipped with a fixed aileron trim tab which could be adjusted only on the ground. It is strongly recommended that an aileron trim tab adjustable from the cockpit during flight be provided if this is not already being done. The relatively small aileron trim-force changes due to unequal fuel consumption from the wing tanks and to changing speed were considered objectionable by NACA pilots.

#### LONGITUDINAL STABILITY AND CONTROL CHARACTERISTICS

Complete longitudinal-stability determinations were not made for any of the various elevator-stabilizer combinations tested but items not investigated were those having little importance in a general evaluation of the airplane. Due to the interim nature of this report it is impossible to include all of the flight results which have been obtained since many of the results are not yet plotted in suitable form. Where this applies, the data obtained will be described without reference to illustrative figures. The various longitudinal-stability tests are treated in the approximate chronological order in which the tests were made.



### Original Horizontal Tail Surfaces

The original P-63A-1 horizontal tail surfaces had the plan form shown in figure 4(a). The elevator was fabric covered and its ribs were  $8\frac{1}{2}$  inches apart on the average. The elevator section shape is shown in figure 5(a). It may be noted that the elevator surfaces in the trailing-edge region were flat and formed an acute angle of about  $13^\circ$ . The original stabilizer incidence was  $2.7^\circ$  nose up with respect to the airplane thrust axis.

Static longitudinal stability.- The static longitudinal stability of the original P-63A-1 airplane is shown in figures 10 and 11 for power on and power off, respectively. When the airplane was trimmed for zero elevator stick force at 300 miles per hour indicated airspeed, the variation of stick force with speed always went in the wrong direction at higher speeds. This characteristic was extremely undesirable. It was caused by aeroelastic distortion of the horizontal stabilizer and elevator due to the combination of a too high positive stabilizer incidence and a very flexible elevator covering. Further analysis of the elevator-angle variations with speed indicated that the center of gravity for which neutral stability would occur with stick fixed was at 32 percent of the mean aerodynamic chord with either power on or off at 10,000 feet altitude for speeds at which the airplane would be flown for protracted periods of time. The significance of this measurement is that it establishes an extreme rearward center-of-gravity limit beyond which the airplane should not be flown even if acceptable stick-force characteristics are present. As can be seen from figures 10 and 11, the stick-force characteristics of the original P-63A-1 airplane in straight flight were unsatisfactory at all center-of-gravity positions at high speed.

Maneuvering longitudinal stability.- The maneuvering stability of the original P-63 airplane was investigated by determining the average stick force required to produce a unit change in normal acceleration and the average change in elevator angle required per unit change in airplane normal-force coefficient in essentially steady turns up to  $4g$  total acceleration and up to 300 miles per hour indicated airspeed for

two center-of-gravity positions. Summary curves of the results obtained are shown in figure 12. These results indicate the stick-force gradient would be zero if the center of gravity were at 29.2 percent of the mean aerodynamic chord and turns were made at 10,000 feet altitude. Actually, to have an acceptable minimum stick-force gradient of about 3 pounds per g, the permissible center-of-gravity location would have to be kept forward of 26 percent mean aerodynamic chord. Even this restriction would not insure desirable turning stability at higher altitudes since it is usual for longitudinal maneuvering stability to deteriorate with decreasing air density (increasing altitude).

#### Incidence and Elevator Modifications with Original Horizontal Stabilizer

As a result of the generally poor longitudinal-stability characteristics of original production P-63 airplanes, a conference was held between United States Army Air Force, Materiel Command, Bell Aircraft Corporation, and NACA representatives to discuss means of improving the various unsatisfactory stability characteristics. As a result of this conference, plans were made to investigate the effects of stabilizer-incidence setting, elevator stiffness, and elevator cross-sectional shape as a means of improving the stick-free longitudinal-stability characteristics of the airplane. Definite objectives set up were the elimination of the stick-force reversal at high speed in straight flight and the attainment of the elevator balance characteristics necessary to give stick-force gradients which would always be between 3 and 8 pounds per g at any altitude up to 25,000 feet and for any center-of-gravity position between 20 and 30 percent of the mean aerodynamic chord. The following discussion describes the work done toward obtaining these objectives.

Effect of stabilizer incidence and elevator fabric distortion on static longitudinal-stability characteristics.— The P-63A-1 airplane (AAF No. 42-68889) used in testing the modifications referred to above was practically identical to the original P-63A-1 tested (AAF No. 42-68861) except that the elevator plan form was changed by providing a cut-out as is shown in figure 6(b). This modification was made by the

Bell Aircraft Corporation to improve rudder effectiveness in spin recoveries. The longitudinal-stability characteristics were not notably changed from those of original P-63A-1 airplanes.

It was generally believed that the stick-force reversal in high-speed straight flight was caused by an improper high stabilizer incidence and by resultant objectionable changes in elevator cross-sectional shapes due to fabric distortion. To cure this condition the stabilizer incidence was reduced from  $2.7^\circ$  to  $1.1^\circ$ , and the original elevator having unsupported spanwise fabric bays of 8 inches (see fig. 13) was replaced by an elevator of the same cross-sectional shape having twice as many ribs, which cut down the fabric bay width to  $3\frac{2}{4}$  inches on the average. (See fig. 14.)

Figure 15 shows a comparison between static longitudinal stability characteristics of the original and modified stabilizer-incidence, elevator-stiffness combinations. It may be noted that with the stabilizer incidence at  $1.1^\circ$  the elevator is practically lined up with the stabilizer at high speeds so that there is practically no tendency for fabric bowing to warp the elevator mean camber line and hence cause undesirable stick-force variations. This is borne out by the stick-force measurements shown in figure 15 since no force reversal occurred with the lowered incidence, stiffer-elevator combination.

In order to gain a more complete knowledge of the effects of stabilizer incidence and fabric distortion, pictures were taken in flight of the upper and lower elevator surfaces for each of the two combinations tested. Examples of such pictures taken in level flight at an indicated airspeed of approximately 350 miles per hour are shown in figure 16. From pictures such as these the elevator section shapes at the middle of representative fabric panels were determined at various speeds in straight flight and at various normal accelerations in turning flight at constant indicated airspeeds. Results of these determinations covering the case of changing speed in straight flight are shown in figures 17 and 18 for the original elevator and the double-ribbed elevator, respectively. The section shapes for changing acceleration are omitted because it was found that the amount of fabric distortion was sensibly independent of normal acceleration at a constant

indicated airspeed. An examination of figures 17 and 18 indicates that by doubling the number of elevator ribs the maximum fabric distortion at the center of an elevator panel was cut to about one-fifth its original amount at a given speed. This agrees well with theory which indicates the maximum fabric distortion for essentially constant pressure differentials should be in proportion to the square of the unsupported panel gap distance.

Summarizing the results of the investigation to correct stick-force reversal at high speeds, the following points may well be reemphasized:

The stabilizer-incidence setting of  $1.1^\circ$  nose up from the thrust axis is satisfactory since no stick-force reversal with increasing speed exists with this incidence setting. This lowered stabilizer incidence has been adopted for production P-63 airplanes. If any further incidence changes are made they should be in a downward direction since this should tend to increase further stick-free stability at high speeds. It is felt that on an airplane capable of speeds often encountered by the P-63 airplane, the elevator rib spacing should not exceed about 4 or 5 inches if fabric is to be used for covering since the extreme fabric distortion occurring with greater rib spacings raises doubt of structural integrity regardless of stabilizer-incidence setting. Although a metal-covered elevator would be desirable to reduce distortion effects, the use of fabric-covered elevators is not necessarily undesirable so long as enough ribs are used to back up the flexible fabric covering.

Effect of elevator cross-sectional shape on stick-force characteristics. - The second objective of the flight-test program was, as stated previously, to develop an elevator giving stick-force gradients in steady accelerated flight always between 3 and 8 pounds per g at either 5,000 or 25,000 feet altitudes at any center-of-gravity position between 20 and 30 percent of the mean aerodynamic chord. To define the starting point of the problem more clearly, tests were first carried out with original-contour elevators to establish definitely their characteristics in steady accelerated flight at 5,000 and 25,000 feet altitudes. The cross-sectional shape of original-contour elevators is shown in figure 5(a) and the horizontal-tail plan form was that

shown in figure 4(b). The rib spacing on the elevators averaged  $4\frac{1}{4}$  inches between center lines.

Testing technique consisted in making steady turns at various steady accelerations with different constant indicated airspeeds at 5,000 and 25,000 feet altitudes. The data were plotted as stick force and elevator angle required to trim against normal acceleration in multiples of the acceleration of gravity. An example of such a plot is shown in figure 19. From plots of this form the stick-force gradient was found by dividing the average stick-force increment between 1g and 5g by 4. Then, to determine the stick-free maneuver point (center-of-gravity position at which stick-force gradient would be zero) the stick-force gradients at different center-of-gravity positions were plotted as a function of center-of-gravity position, as is shown in figure 20, and straight lines were drawn through the test points. The pertinent points brought out by the data for original-contour half rib-spaced short-chord elevators, shown in figure 20, were the following:

In the critical 25,000-foot-altitude condition, the most aft center-of-gravity position at which a stick-force gradient of 3 pounds per g could be obtained was about 24 percent mean aerodynamic chord. Furthermore, the rate of change of stick-force gradient with center-of-gravity position was such that the force gradient limits of 3 to 8 pounds per g could be met over only 5 percent mean aerodynamic chord instead of the desired 10-percent range, excluding consideration of the loss in stick-force gradient with increasing altitude. It was therefore concluded that the elevator balance was insufficient to meet the desired objective.

Two new elevators were designed and built which incorporated increased trailing-edge angles as a means of increasing the aerodynamic balance. Cross sections of these elevators are shown in figures 5(b) and 5(c), respectively. One of these elevators (fig. 5(b)) was fabric covered with a rib spacing of  $4\frac{1}{4}$  inches and its average trailing-edge angle was  $21.3^\circ$ . Preliminary tests indicated these elevators were too highly balanced, so the balance was then reduced to obtain the desired amount by adding 9-inch long strips of  $\frac{1}{8}$ -inch diameter wire on the upper and lower surfaces, at the elevator



trailing edge, on each side of the airplane at elevator midspan. The other elevator (fig. 5(c)) was metal covered and had an average trailing-edge angle of  $17.0^\circ$ . These elevators had about a  $\frac{1}{2}$ -inch greater chord than either the original contour or the fabric-covered bulged elevators. No extra balance modifications were necessary with the bulged metal-covered elevators.

Summaries of the stick-force characteristics of the airplane with the bulged elevators installed are shown in figures 20 and 21. It may be noted that the variations of stick-force gradient with center-of-gravity position were almost small enough to meet the objective but that the stick-force gradients were too low at rearward center-of-gravity positions. This was corrected by installing a 2.3-pound bobweight in the elevator control system in the case of the fabric-covered bulged elevators and a  $3\frac{1}{4}$  pound bobweight in the case of the metal-covered bulged elevators. A bobweight is simply weight unbalance in the elevator control system which adds stick force in proportion to the normal acceleration on the airplane. In level, or 1g, flight the stick-force increment due to the bobweight is trimmed out with the elevator trim tab. The actual variations of stick force with acceleration were very satisfactory with the bulged elevators as can be seen from the typical plot shown in figure 22. Besides supplying the desired stick-force characteristics in steady accelerated flight, the bulged elevators gave excellent static stability characteristics, an example of which is shown in figure 23. Also, the elevator-free short-period oscillation characteristics were satisfactory. In spite of all these good points, however, some bad control-feel characteristics were inherent in the use of these highly balanced elevators.

First, the stick was unusually easy to deflect when rapid longitudinal maneuvers were made. In most airplanes larger stick forces are required to reach a given maximum normal acceleration in fast maneuvers than in slow maneuvers. With very highly balanced elevators the reverse is true. The bulged elevators, then, tended to make proper control difficult in abrupt maneuvers when the center of gravity was rearward and only small stick movements were necessary to produce large normal accelerations.

Second, the control feel was objectionable when flying in rough air. Whenever the airplane hit a gust the stick would immediately tend to move in a direction to return the airplane to its trim condition. The stick forces accompanying these self-induced restoring tendencies were objectionable to the pilot, who described the action as "stick bouncing." A part of this trouble was undoubtedly due to the bobweight installation and a part was attributed to the tendencies of these highly balanced elevators to float against the relative wind whenever a change in angle of attack occurred.

Summing up this portion of the investigation, it appears that the satisfactory control-feel characteristics associated with the small aerodynamically balanced original-contour elevators can be obtained only at the expense of having a restricted center-of-gravity range where steady flight stick-force characteristics are altogether desirable. On the other hand, desirable steady flight stick-force characteristics can be obtained over a large center-of-gravity range if certain poor control-feel characteristics can be accepted. This analysis overlooks the possibility that some type of artificial dampener might be developed to improve control-feel characteristics of highly balanced elevators. In connection with the poor control-feel characteristics explained above, it was noted by the pilot that the undesirable characteristics tended to become less noticeable as familiarity with them increased.

The longitudinal characteristics with an enlarged horizontal tail are discussed in a subsequent part of this report.

Ability to raise nose wheel on take-off.- In the course of running longitudinal-stability tests, measurements were made of the elevator effectiveness available to raise the nose wheel from the ground in take-off runs on a concrete runway and of the ability of the elevator to hold the airplane off the ground until minimum air-speed had been reached on landing. All tests were made with the horizontal tail plan form shown in figure 4(b) and with the elevators represented by figures 5(a), 5(b), and 5(c).

The test procedure in take-off was to hold the elevator up until the nose wheel came off the ground at which time the airspeed was recorded. Various up-elevator deflections were used in these runs up to nearly full-up elevator angle. The results are plotted in figure 24 showing airspeed at which the nose wheel raised as a function of center-of-gravity position. A dash line has been faired to indicate the estimated variation of minimum speed to raise the nose wheel, using full-up elevator deflection, with center-of-gravity position.

It may be concluded that the P-63A-1 airplane has sufficiently great elevator power in take-off with any of the elevators tested since the nose wheel could easily be raised from the ground before 0.8 of the normal take-off speed had been reached with the center of gravity at its most forward limit (20 percent mean aerodynamic chord).

Elevator control in landing.- Testing technique to find if sufficient elevator effectiveness were available for making minimum speed landings consisted in making power-off landings with flaps full down in which the pilot attempted to hold the airplane off the ground until the stall occurred. Landings were made with various center-of-gravity positions. The maximum recorded up-elevator angles required to perform such landings are shown in figure 25.

Figure 25 indicates the available elevator power is slightly deficient to make minimum-speed landings with center-of-gravity positions forward of 22 percent of the mean aerodynamic chord. Since this deficiency is only marginal and since the power-off landing test condition is the severest possible, it may be concluded that the P-63A-1 airplane has sufficient elevator power to make minimum-speed landings in any condition it is likely to be used in service.

#### Enlarged Horizontal Tail Surfaces

Because of the difficulty in acquiring sufficient longitudinal stability at rearward center-of-gravity positions, the Bell Aircraft Corporation recently put into production an enlarged horizontal tail having an increased aspect ratio. The dimensional characteristics

of this horizontal tail are given in the appendix and the plan form is shown in figure 4(c). This larger tail provided a rearward shift in the center-of-gravity position for neutral stick-fixed stability of about 2 percent mean aerodynamic chord. The stick-free stability for a given elevator shape should, of course, be affected in a similar manner. Present production P-63 airplanes are being fitted with original contour elevators having the cross section shown in figure 5(a). Even with the gain in stability provided by using the larger horizontal tail, however, the problem of supplying adequate stick-force gradients at rearward center-of-gravity positions and high altitudes appears critical. At the request of the United States Army Air Forces, Materiel Command, the NACA designed and is testing another set of bulged fabric-covered elevators in an effort to determine the best type of elevator for use with the enlarged horizontal tail. In the present test program the attainment of desirable stick-force characteristics at rearward center-of-gravity positions is being sought without resort to the use of a bobweight.

Characteristics with modified elevators.- A cross section of the NACA designed bulged elevators is shown in figure 5(d). These elevators have been tested only at 5000 feet altitude to date. Two configurations have so far been tested; first, with the elevator-stabilizer gap open between  $1/8$  and  $1/4$  inch along its entire length, and second, with a positive curtain seal across the gap along the entire length of the elevators except at the hinges.

Without the seal installed, the stick-force characteristics were unsatisfactory because the aerodynamic balance was too great. In straight flight the variation of stick force with speed was almost negligible as can be seen in figure 26. In turning flight the stick-force gradients were insufficiently high at all except forward center-of-gravity positions. This is shown in figure 27. Furthermore, the stick forces required to make abrupt maneuvers were much too low.

With the curtain seal installed the aerodynamic balance characteristics were improved. The variation of stick force with speed in straight flight was satisfactory as can be seen from figure 28. The stick-force gradients in steady turning flight were increased somewhat for forward center-of-gravity positions but

were apparently reduced at far rearward center-of-gravity positions. (See fig. 29.) The control feel in abrupt maneuvers was improved.

Further modifications may be attempted with this set of bulged elevators in the near future.

Predicted characteristics with present production elevators.- Although no flight tests have been made at the NACA to determine the longitudinal-stability characteristics of present-production P-63 airplanes with original-contour flat-sided elevators on the enlarged horizontal tail, it is felt that a fairly accurate prediction can be made of the over-all steady turning stability characteristics of the airplane on the basis of the accumulated test data gathered in previous tests of P-63 airplanes at the NACA. Such a prediction has been made and is presented in figure 30.

From figure 30 it may be concluded that the stick-force gradients will be very low for rearward center-of-gravity positions at high altitudes and quite high at forward center-of-gravity positions at low altitude. Control-feel characteristics in rapid maneuvers should be satisfactory with this configuration.

#### DIRECTIONAL STABILITY AND CONTROL CHARACTERISTICS

During the course of the longitudinal-stability flight test programs, it was found that the directional stability of the P-63A-1 airplane was inadequate. In turn entries, small inadvertent motions of the rudder caused large amounts of skidding. Also, in certain steady flight conditions, an undamped directional oscillation existed even when the pilot attempted to hold all the controls absolutely fixed. A time history of such an oscillation is shown in figure 31. Due to the apparent weak directional stability of the airplane, measurements of its directional characteristics in typical maneuvers were made and then the same tests were repeated after an enlarged vertical tail had been installed to make the directional stability more satisfactory. Outlines of both the original and enlarged vertical tails tested are shown in figure 6. Dimensional characteristics of both vertical tails are given in the appendix. Figure 7 contains reproduced views of the airplane with



the modified vertical tail installed. The dorsal fin shown in figure 7 is a recent addition which has not yet been formally tested.

#### Directional Characteristics in Sideslips

The results of all the sideslip tests made with each vertical tail installed on the airplane are shown in figures 32 to 38, inclusive. The following table is a key showing the airplane conditions corresponding to each set of sideslip data:

Figure no.	Service indicated airspeed (mph)	Power conditions	Altitude (ft)
32	150	Engine idling	5,000
33	150	Normal rated (2600 rpm, 43 in. Hg.)	5,000
34	250	-----do.-----	5,000
35	300	-----do.-----	5,000
36	400	-----do.-----	5,000
37	150	Power on (2600 rpm, 38 in. Hg.)	22,000
38	250	Power on (2600 rpm, 39 in. Hg.)	25,000

An examination of these data shows that, in general, about twice as much rudder force and rudder deflection is required to produce a given change in sideslip angle with the enlarged vertical tail as with the original. Furthermore, the rudder-force reversal, which occurs in low-speed high-power conditions (figs. 33 and 37), occurs at much higher sideslip angles with the enlarged vertical-tail installation. In this connection, the dorsal fin shown in figure 7 was built for the express purpose of eliminating the rudder-force reversal altogether. Preliminary tests with this dorsal fin installed indicate that it does accomplish complete elimination of the rudder-force reversal.

Pilots noted the directional stability of the airplane was much more satisfactory after installation of the enlarged vertical tail. Inadvertent skidding during abrupt maneuvering was greatly reduced. There was no tendency for the airplane to perform self-induced oscillations in a directional sense. The steadiness of the airplane as a gun platform was improved. It may be pointed out here that the desired amount of directional stability can very likely be obtained by installing a ventral fin beneath the fuselage in addition to increasing the height of the original vertical tail by the amount done in NACA tests. Such an addition would be advantageous from directional stability, spin recovery, and vertical-tail-load considerations. One possible disadvantage of installing a ventral fin would be the change in ground clearance angle accompanying its installation. Tests at the NACA indicate nearly the entire original ground clearance angle is needed to effect minimum-speed landings. If a very deep ventral fin is added some minor difficulty may be encountered due to hitting the tail on the ground when making minimum-speed landings.

#### Directional Trim Characteristics

The variation in rudder force with speed to maintain wings-level straight flight with a constant rudder tab setting and the accompanying rudder-angle variation with speed for the original vertical tail on the airplane are shown in figure 39. Similar data obtained with the enlarged vertical tail on the airplane are shown in figure 40. A comparison of these figures shows that no noticeable change in directional trim characteristics was brought about by enlarging the vertical tail.

The directional trim characteristics of the P-63 airplane are excellent. The relatively small change in rudder force with speed indicates very little use of the rudder trim tab need be made in normal flight conditions. Since only about  $20^\circ$  of rudder deflection out of a possible  $30^\circ$  are necessary to maintain straight, laterally level flight at stalling speed with high power, the rudder effectiveness is entirely adequate in flight.

### Yaw Due to Aileron Action

The ability of the vertical tail to balance out yawing moments due to aileron deflection and rolling is a very important factor in a consideration of directional stability, particularly in the case of highly maneuverable fighter airplanes. One series of directional stability tests made with the P-63A-1 airplane consisted in determining what maximum sideslip angles were reached when the ailerons were abruptly deflected various amounts at various indicated airspeeds and under various amounts of normal acceleration attained by pulling out of dives. In these tests the rudder was held fixed in its trim position until after the maximum sideslip angle due to aileron action had been reached.

Theory indicates the yawing moment due to aileron deflection and rolling is a direct function of airplane normal-force coefficient. For this reason the results of all abrupt rolling maneuvers were plotted as the maximum change in sideslip angle divided by the airplane normal-force coefficient against total aileron deflection from trim. The resulting test points form a single curve, which is significant because its slope is inversely proportional to the directional stability of the airplane. Data obtained and evaluated in this manner for the P-63 airplane are shown in figures 41 and 42. Figure 41 covers rolls made over a range of normal accelerations at constant indicated airspeed while figure 42 covers rolls made over a range of speeds at constant normal acceleration.

This series of tests showed that the airplane would sideslip only 63 percent as much with the enlarged vertical tail as it would with the original vertical tail installed for a given yawing moment caused by aileron deflection and rolling.

### Vertical-Tail Loads Due to Aileron Action

By using the data given in figures 41 and 42 the vertical-tail dimensional characteristics given in the appendix and the aileron-characteristics data of figure 9, estimates were made of the maximum vertical-tail

loads which would be expected due to the application of 50 pounds of aileron stick force during accelerated flight. These estimates are portrayed graphically in figure 43.

It will be seen that the vertical-tail loads likely to be produced due to aileron action would exceed the design strength of the vertical tail for the gust condition if fast rolls were made above about  $3g$  normal acceleration. This indicates an immediate need for increasing the vertical-tail strength and also, very likely, for increasing the torsional strength of the fuselage. Under given aileron-deflection conditions the vertical-tail load appears to be somewhat lower for the enlarged vertical tail. This is due to the large directional-stability increase which restricts the maximum sideslip angles caused by rolling to much smaller values. When the sideslip angles are restricted the unstable fuselage and propeller yawing moments are reduced and, hence, the vertical-tail loads are also reduced.

In case the aileron-control characteristics are further improved, attention should immediately be given to the question of further increases in vertical-tail and fuselage-torsional strength. The pertinency of these load considerations have already been demonstrated by the loss of some P-63 airplanes due to vertical-tail-fuselage failures in fast rolling maneuvers.

## C O N C L U S I O N S

On the basis of stability and control tests conducted by the NACA on models and airplanes of the P-63 type, the following summary evaluation of the airplane is indicated.

## Spin Characteristics

Spin tests of a  $\frac{1}{15}$ -scale dynamic model indicated that recoveries from fully-developed spins of the full-scale airplane should be effected in two turns or less if the rudder is fully reversed against the spin and the elevator is then put down. For small airplane gross weights and without wing guns installed, the position of the ailerons during spin recovery is not critical between the deflection ranges of one-third of full aileron deflection either with or against the spin. For high gross weights and/or with wing guns installed, it is necessary to put ailerons against the spin for rapid recovery. Spin recoveries will probably be improved if any one or a combination of the following modifications are made to the original P-63A-1 airplane:

(a) Adding a ventral fin and/or rudder area beneath the fuselage

(b) Increasing the height of the original vertical tail

(c) Installing horizontal dorsal fins ahead of the stabilizer

Flight tests of P-63 airplanes showed that the stall-warning characteristics of the airplane are excellent, so that little trouble is anticipated due to inadvertent spinning.

## Lateral Control Characteristics

Flight tests showed that the aileron characteristics of the P-63 airplane compare favorably with those of other contemporary fighter airplanes. The ailerons are exceptionally effective per unit area and per unit deflection. Since the deflection range is now only  $\pm 15^\circ$  and since the hinge-moment variations with deflection are desirably linear, it appears that minor modifications



involving slight increases in the aerodynamic balance and the total deflection range of the ailerons can easily be effected to make the aileron characteristics outstandingly good, particularly at high speeds. Such modifications, if made, will probably necessitate increasing the strength of the ailerons and will certainly require an increase in vertical-tail strength along with some probable necessary increase in fuselage torsional strength. The aileron control system in the airplane tested at the NACA was excessively flexible. If this is a general condition in production airplanes, steps should immediately be taken to increase the rigidity of the aileron control system since excessive flexibility needlessly penalizes the rolling performance of the airplane at low and intermediate indicated air speeds. The provision of an aileron trim tab, adjustable from the cockpit in flight, is strongly recommended.

### Longitudinal Stability and

### Control Characteristics

Because of an incorrect high stabilizer incidence and an unusually flexible elevator covering for such a high-speed airplane, original P-63A-1 airplanes possessed extremely undesirable stick-force variations with speed in the high-speed range. These characteristics, consisting of stick-force reversals with increasing airspeed, were eliminated by reducing the stabilizer incidence from  $2.7^\circ$  to  $1.1^\circ$ . Due to very great elevator fabric distortion at high speed it is recommended that the elevator rib spacing for the P-63 airplane should not exceed 4 or 5 inches for fabric-covered elevators. Metal-covered elevators are desirable although a resort to them does not appear necessary if sufficient ribs are used to back up a fabric covering.

The stick-fixed stability characteristics of original P-63A-1 airplanes in both straight and turning flight were generally satisfactory. The present production enlarged horizontal tail surfaces tend to improve further stick-fixed longitudinal stability in both straight and turning flight. The stick-free longitudinal-stability characteristics of original P-63A-1 airplanes in straight and turning flight were satisfactory in the forward to middle range of useable center-of-gravity positions. At most rearward useable center-of-gravity positions, the stick-free stability was marginal to negative, particularly at

high altitudes. The present production enlarged horizontal tail surfaces should improve the stick-free stability characteristics at all useable center-of-gravity positions but will tend to make stick forces in turning flight undesirably high at most forward useable center-of-gravity positions, particularly at low altitudes. A small bob-weight (elevator weight unbalance) may be used to adjust the stick-force gradients of airplanes with production contour elevators without great adverse effects on control-feel characteristics. To gain a much more nearly constant stick-force gradient over the entire useable center-of-gravity range at all altitudes, an elevator incorporating greater aerodynamic balance could be used. Such an elevator, however, would possess somewhat poor control-feel characteristics in normal flying and especially in rapid longitudinal maneuvers, as a result of the increased aerodynamic balance.

The elevator power available to raise the nose wheel from the ground in take-off runs is sufficiently great. The nose wheel can be raised from a concrete runway long before 30 percent of the take-off speed is reached even with the most forward permissible center-of-gravity position.

The elevator power available to make minimum speed landings with flaps full down is sufficiently great, although marginal with extreme forward center-of-gravity positions.

#### Directional Stability and Control Characteristics

The directional stability of original P-63A-1 airplanes is inadequate. Excessive inadvertent yawing occurs in abrupt rolling maneuvers and the airplane tends to oscillate directionally even with controls fixed in certain steady flight conditions. The directional stability can be made nearly satisfactory and the value of the airplane as a gun platform can be greatly increased by increasing the height of the original vertical tail about 16 inches, involving a vertical-tail area increase of less than 3 square feet. The use of a relatively small dorsal fin in combination with this taller vertical tail improves the behavior of the airplane at large angles of sideslip in low-speed steady sideslips using high engine powers. Besides increasing the vertical-tail height, a further increase in directional stability appears desirable and

can be accomplished by adding a ventral fin to the taller vertical-tail modification. Such an addition would also be desirable from a spin-recovery standpoint and from vertical-tail aerodynamic-loads considerations. One possible disadvantage of a ventral fin would be that it might change the ground clearance angle enough so that minimum-speed landings could no longer be made without hitting the tail on the ground. In spite of this possible objection, it is recommended that a taller vertical tail and a ventral fin be incorporated in the P-63 airplane to increase its directional stability and, consequently, its value as a gun platform. If the directional stability of the original P-63 airplane is not improved and a larger propeller is installed to take care of possible engine power increases, serious directional-stability difficulties are anticipated. The directional trim characteristics of the P-63 airplane are excellent; rudder-force trim changes due to changing speed are desirably low and the rudder effectiveness is easily adequate to maintain straight, laterally level flight at the stalling speed with high engine powers.

Estimates of the vertical-tail loads which are expected to occur on P-63 airplanes as a result of aileron action during accelerated flight indicate the original vertical tail is insufficiently strong. This probably also applies to the fuselage from a torsional strength standpoint. In connection with vertical-tail loads resulting from rolling, increasing the directional stability of the airplane should bring about a slight reduction in total vertical-tail load for a rolling maneuver of given rapidity. If any improvement is made in the rolling performance of the airplane, further increases in vertical tail and fuselage torsional strength over what now appears necessary should be considered.

Langley Memorial Aeronautical Laboratory  
National Advisory Committee for Aeronautics  
Langley Field, Va., October 19, 1944

## APPENDIX

## GENERAL SPECIFICATIONS AND DIMENSIONS OF AIRPLANE

Name and type . . . . .	Bell P-63A-1 Pursuit - Interceptor
Engine . . . . .	Allison V-1710-93
Rating:	
Take-off . . . . .	1325 hp at 3000 rpm, 54 in. Hg at S.L.
Normal rated . . . . .	1050 hp at 2600 rpm, 43 in. Hg at 10,000 ft
Military rated . . . . .	1180 hp at 3000 rpm, 52 in. Hg at 21,500 ft
Supercharger gear ratio . . . . .	6.85:1
Propeller (special aeroproducts type)	
Diameter . . . . .	11 ft 1 in.
Number of blades . . . . .	4
Engine-propeller gear ratio . . . . .	2.23:1
Fuel capacity (without belly tank), gal. . . . .	136
Weight empty, lb . . . . .	5910
Normal gross weight, lb . . . . .	7650
Wing loading (normal gross wt.), lb/sq ft . . . . .	30.85
Power loading (normal gross wt., 1050 hp), lb/hp . . . . .	7.29
Over-all height (taxying position) . . . . .	11 ft 4 in.
Over-all length . . . . .	32 ft $8\frac{3}{8}$ in.
Wing:	
Span, ft . . . . .	38.33
Area (including section through fuselage) sq ft . . . . .	248
Airfoil section, root . . . . .	NACA 66,2x-116
Airfoil section, tip . . . . .	NACA 66,2x-216
Mean aerodynamic chord, in. . . . .	82.54
Leading edge M.A.C., in. aft L.E. root chord . . . . .	6.11
Aspect ratio . . . . .	5.92:1
Taper ratio . . . . .	2:1
Dihedral (35-percent chord, upper surface), deg. . . . .	3.67
Root incidence, deg. . . . .	1.30
Tip incidence, deg. . . . .	-0.45

## Wing flaps (Plain sealed type):

Total area, sq ft . . . . .	12.9
Span (along hinge line, each), in. . . . .	62.38
Travel, deg. . . . .	45

## Ailerons:

Span (along hinge line, each), in. . . . .	120.75
Area aft of hinge center line, each, sq ft . . . . .	8.143
Fixed balance area, each, sq ft . . . . .	4.826
Location of inboard end of aileron, percent semispan . . . . .	44.2
Location of outboard end of aileron, percent semispan . . . . .	96.7
Travel, deg. . . . .	±15

## Horizontal tail (letters refer to plan forms shown in fig. 4):

	A	B	C
Span, in. . . . .	159	159	175
Total area, sq ft . . . . .	45.15	44.11	46.92
Stabilizer area, sq ft . . . . .	31.80	30.44	34.15
Total elevator area, sq ft . . . . .	13.35	13.67	12.77
Elevator area aft of hinge center line, including tab, sq ft . . . . .	10.38	10.59	9.85
Elevator area forward of hinge center line, sq ft: . . . . .	2.97	3.08	2.92
Elevator trim tab area, sq ft . . . . .	0.92	0.92	0.92
Distance elevator hinge center line to L.E. of M.A.C., in. . . . .	226.28	226.28	226.28
Elevator travel from stabilizer, deg down . . . . .	15	15	15
Elevator travel from stabilizer, deg up . . . . .	35	35	35

## Vertical tail (plan forms shown in fig. 6):

	Original	Enlarged
Height along hinge center line, in. . . . .	78.87	94.62
Total area, sq ft . . . . .	23.73	26.58
Fin area, sq ft . . . . .	13.47	15.96
Total rudder area, sq ft . . . . .	10.26	10.62
Rudder area aft of hinge center line, sq ft . . . . .	8.30	8.65
Rudder area forward of hinge center line, sq ft . . . . .	1.96	1.97
Rudder trim tab area, sq ft . . . . .	0.84	0.84
Distance rudder hinge center line to L.E. of M.A.C., in. . . . .	248.40	248.40
Fin offset from thrust axis, deg. . . . .	0	0
Rudder travel, deg. . . . .	±30	±30

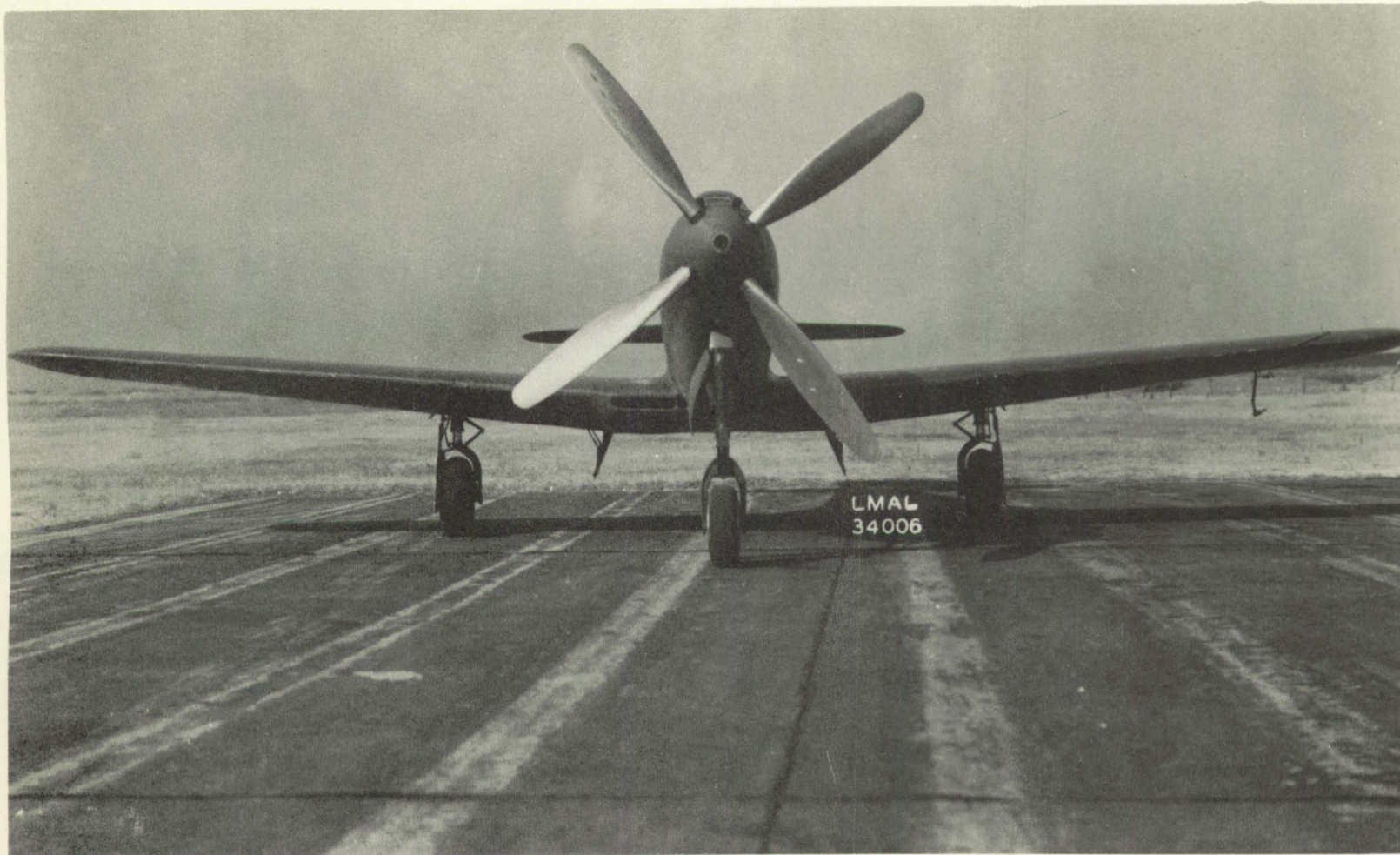

(a) Front view.

Figure 1.- Photographs of original Bell P-63A-1 airplane (AAF No. 42-68861).



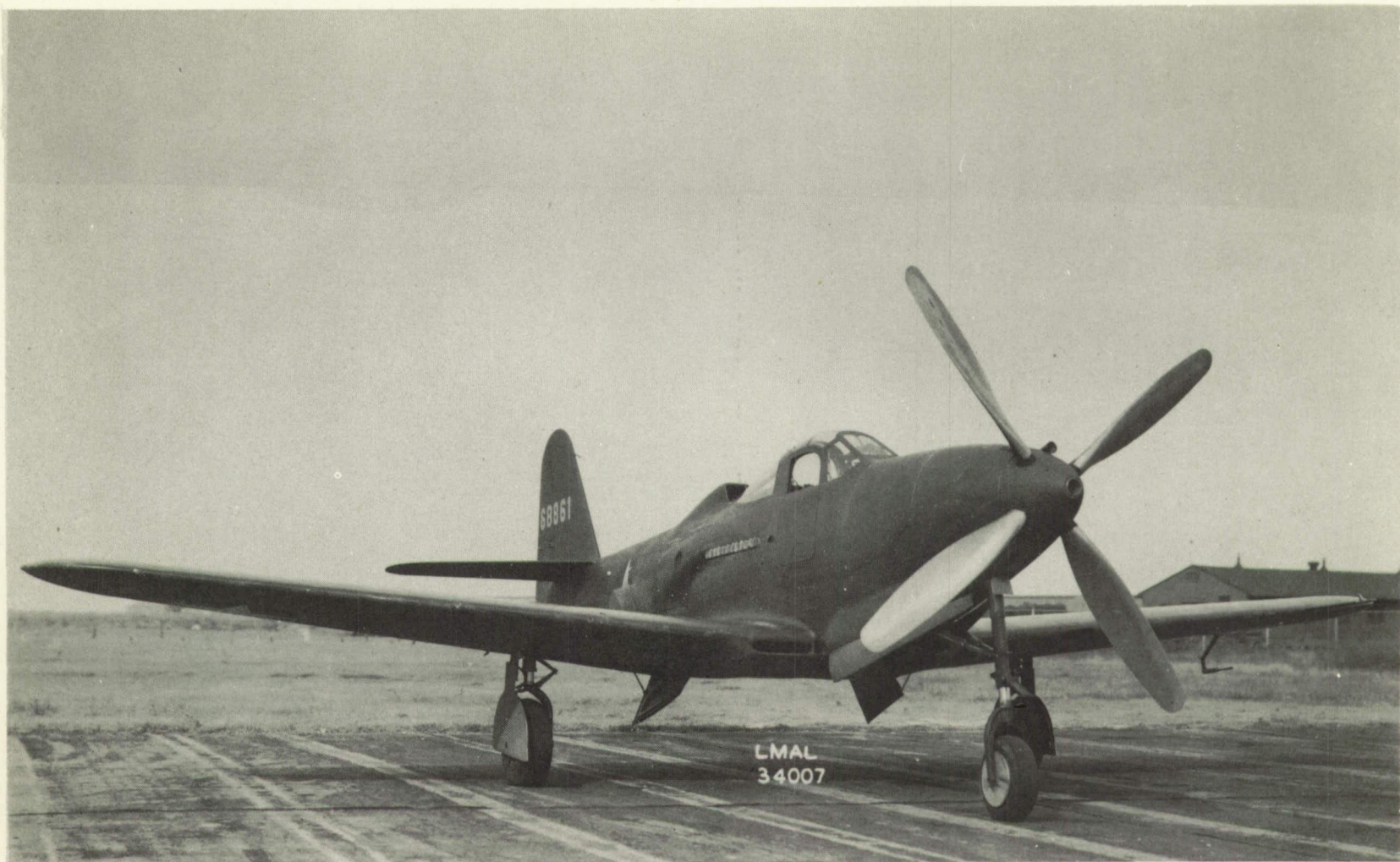

(b) Three-quarter front view.

Figure 1.- Continued.



(c) Side view.

Figure 1.- Continued.





(d) Three-quarter rear view.

Figure 1.- Continued.

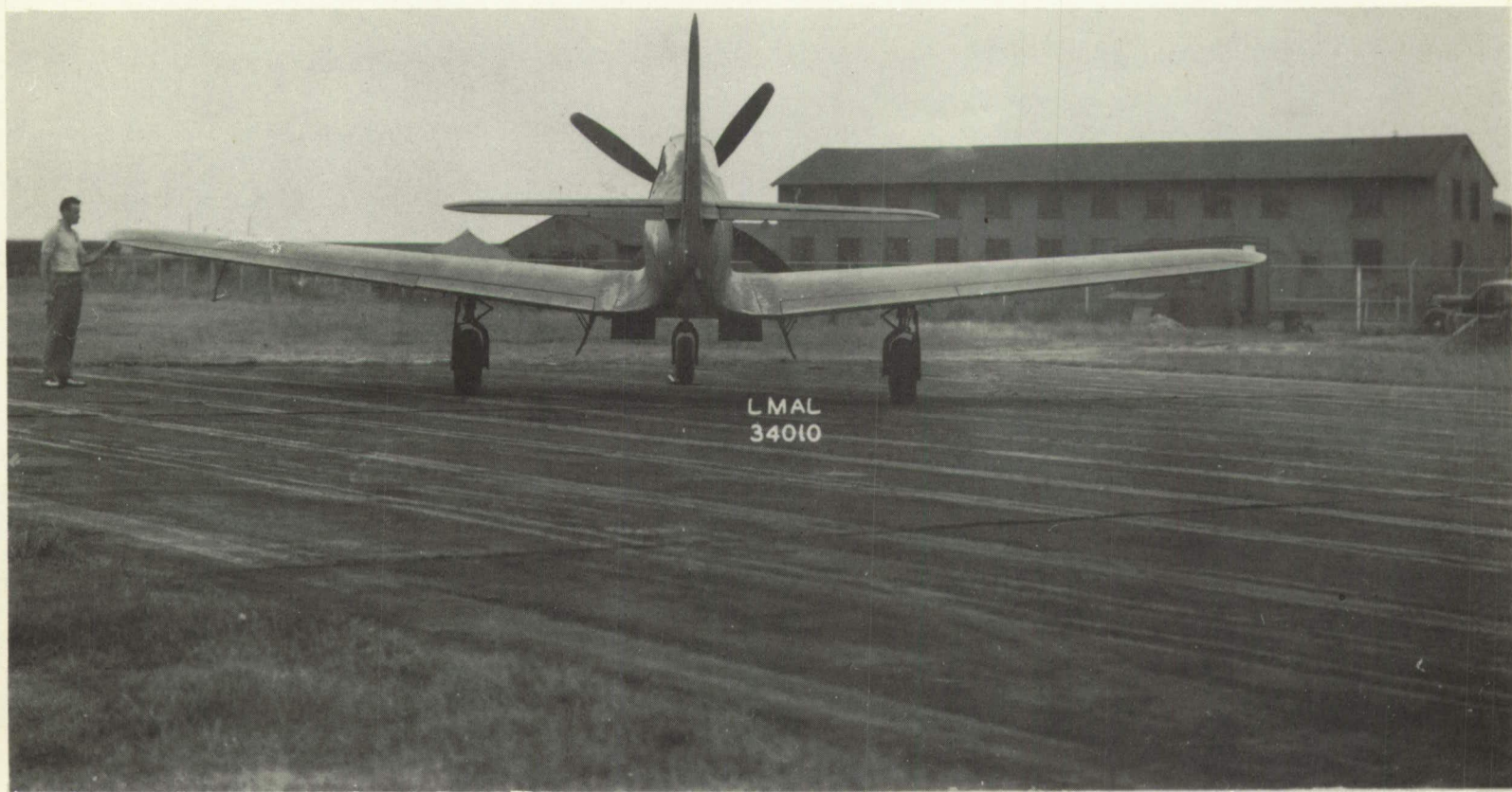

(e) Rear view.

Figure 1.- Concluded.

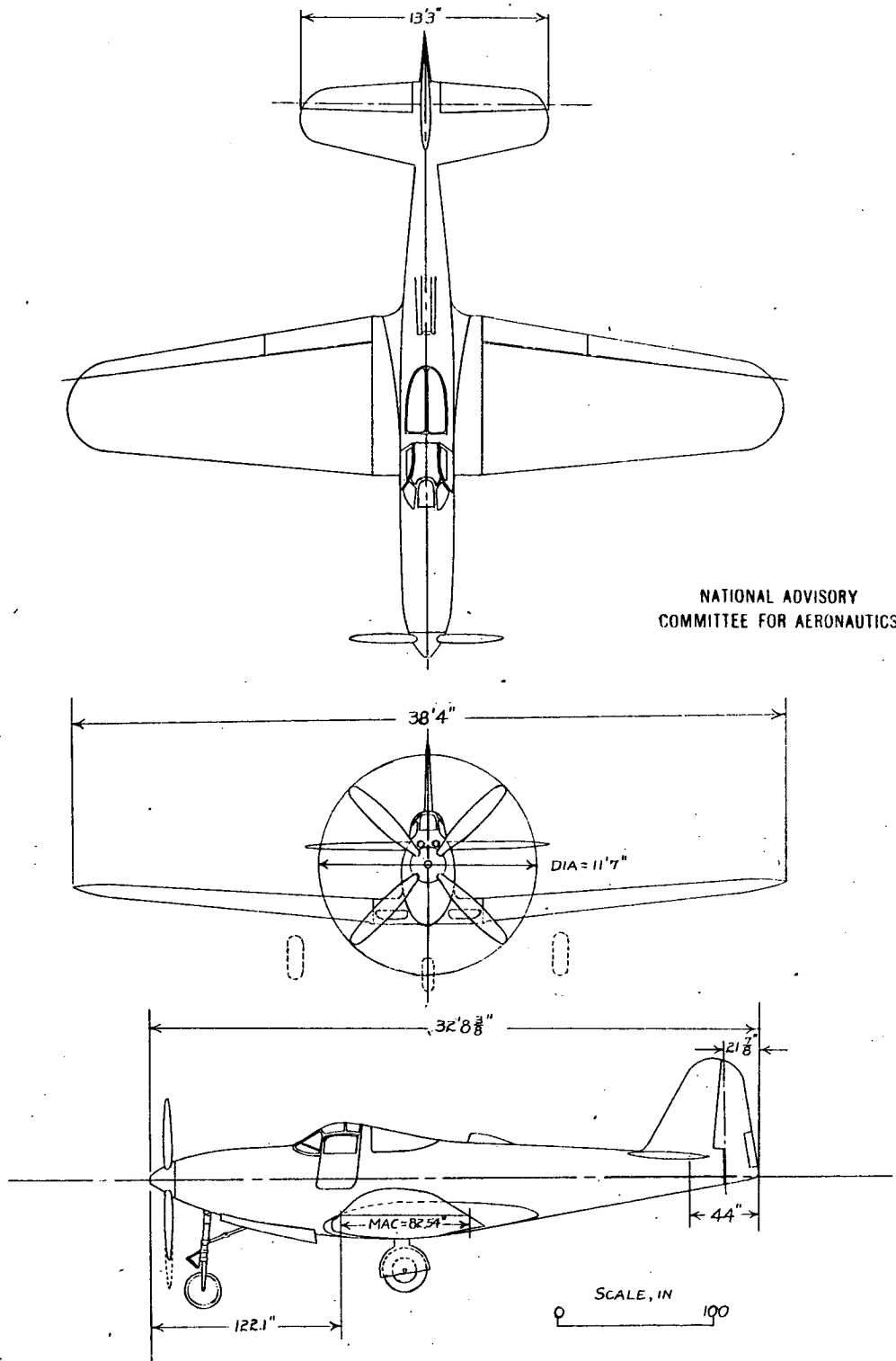

Figure 2.- Three-view drawing of original Bell P-63A-1 airplane.

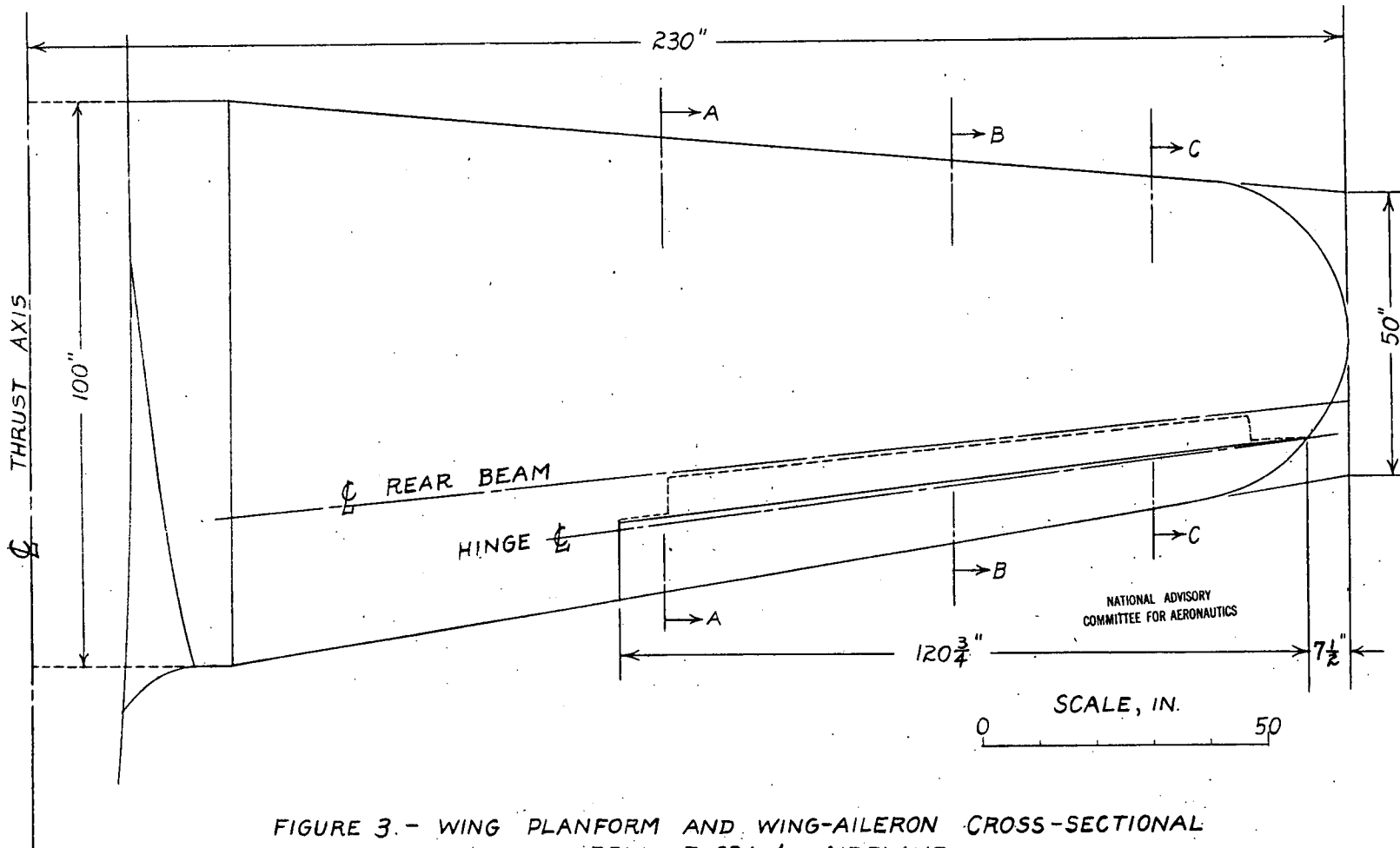

FIGURE 3. - WING PLANFORM AND WING-AILERON CROSS-SECTIONAL OUTLINES OF BELL P-63A-1 AIRPLANE.

(A) WING PLANFORM.

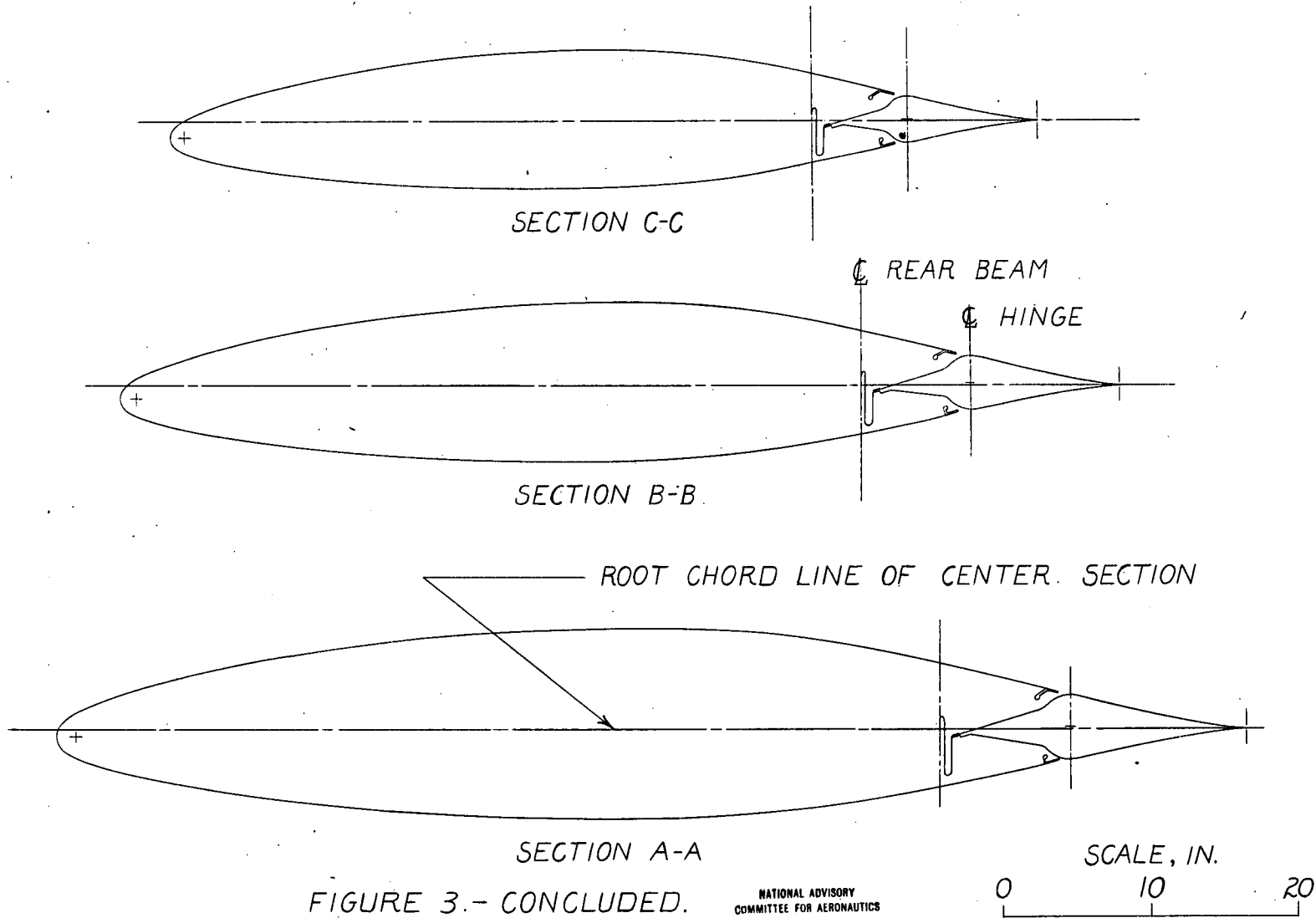
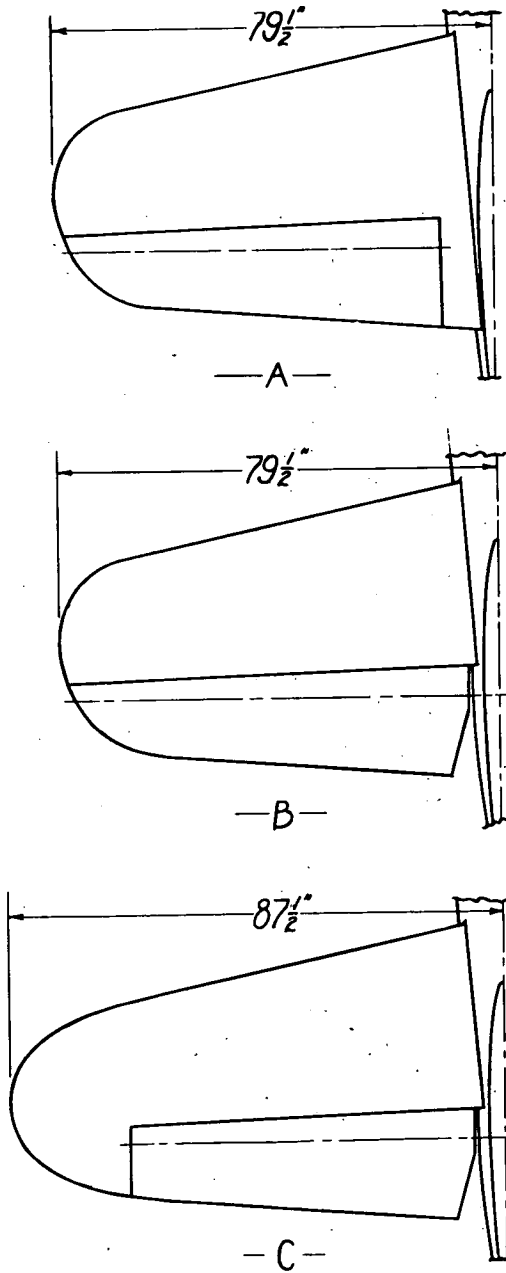

FIGURE 3.- CONCLUDED.

NATIONAL ADVISORY  
COMMITTEE FOR AERONAUTICS

(B) WING-AILERON CROSS-SECTIONAL OUTLINES.



NATIONAL ADVISORY  
COMMITTEE FOR AERONAUTICS

Figure 4. - Planforms of horizontal tails tested on the P-63A-1-BE airplane

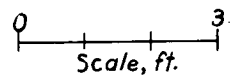

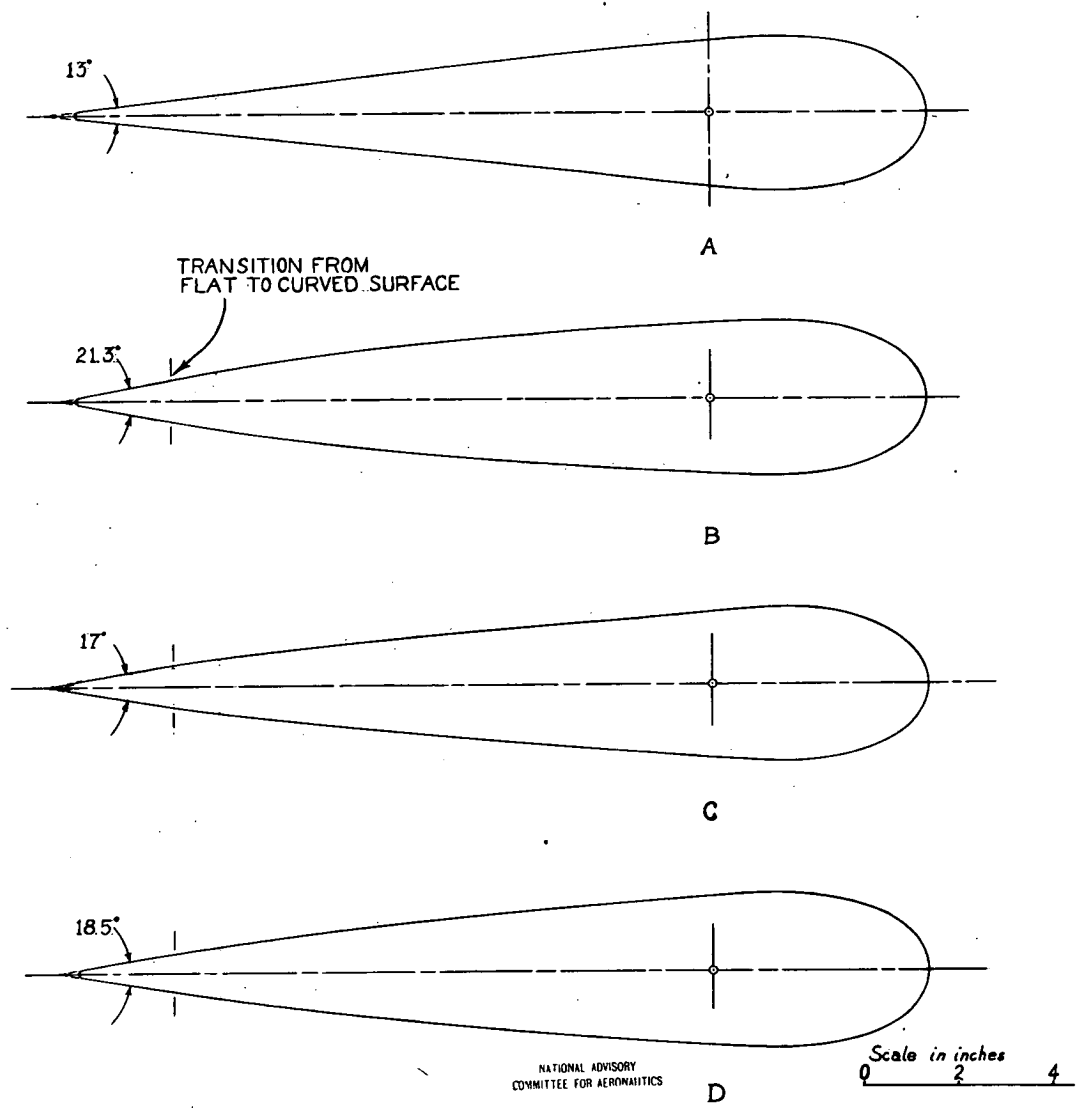

FIGURE 5-CROSS-SECTIONAL OUTLINES OF THE VARIOUS ELEVATORS TESTED ON THE P-63A-1 AIRPLANE. SECTIONS ARE FOR SPANWISE STATIONS 15 INCHES FROM AIRPLANE CENTERLINE.

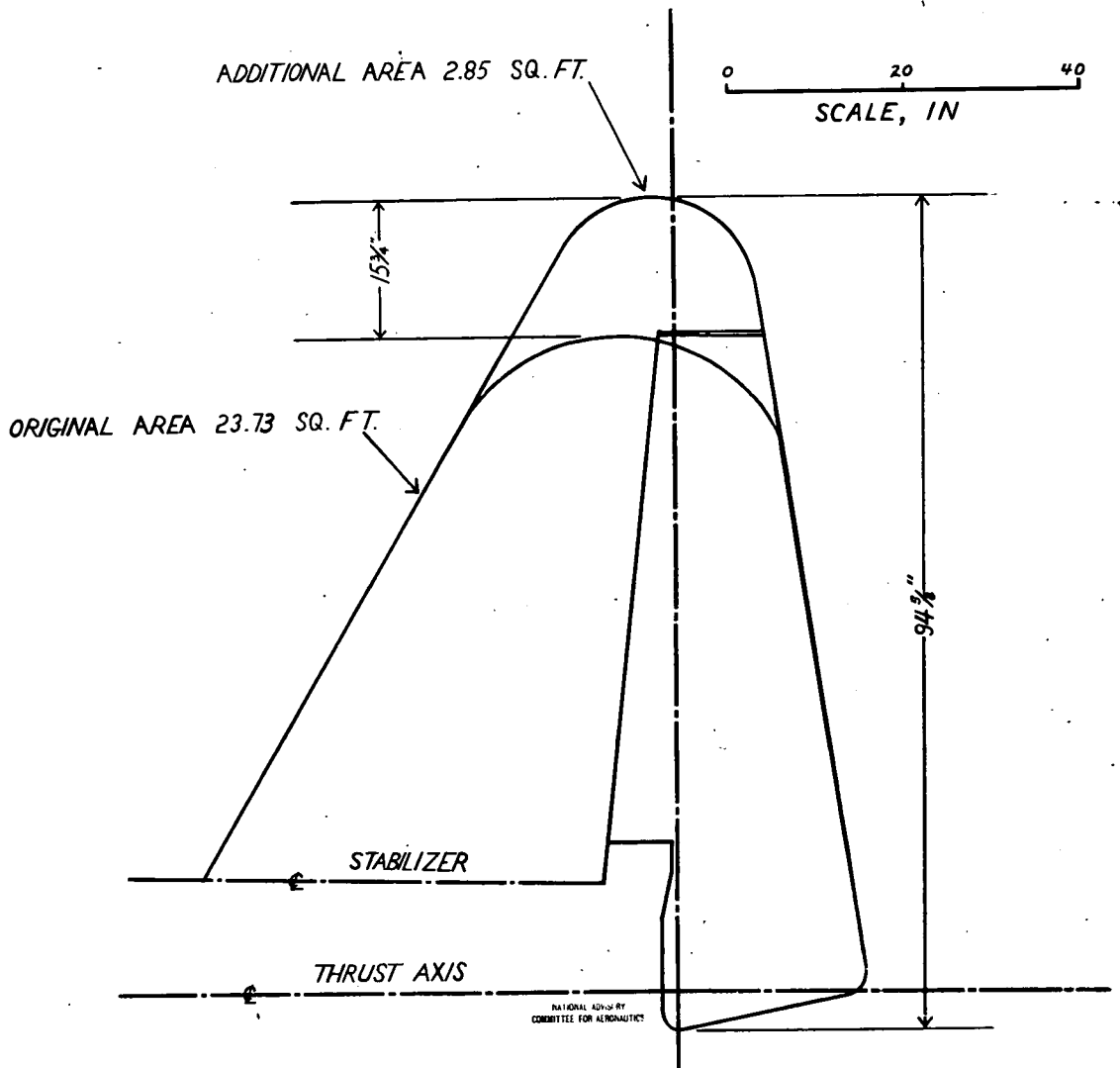

FIGURE 6. - ORIGINAL AND ENLARGED VERTICAL TAIL SURFACES TESTED ON P-63A-1 AIRPLANE





(a) Three-quarter front view.

Figure 7.- Three-view photographs of modified P-63A-1-BE airplane presently being tested at the NACA.





(b) Side view.

Figure 7.- Continued.





(c) Three-quarter rear view.

Figure 7.- Concluded.

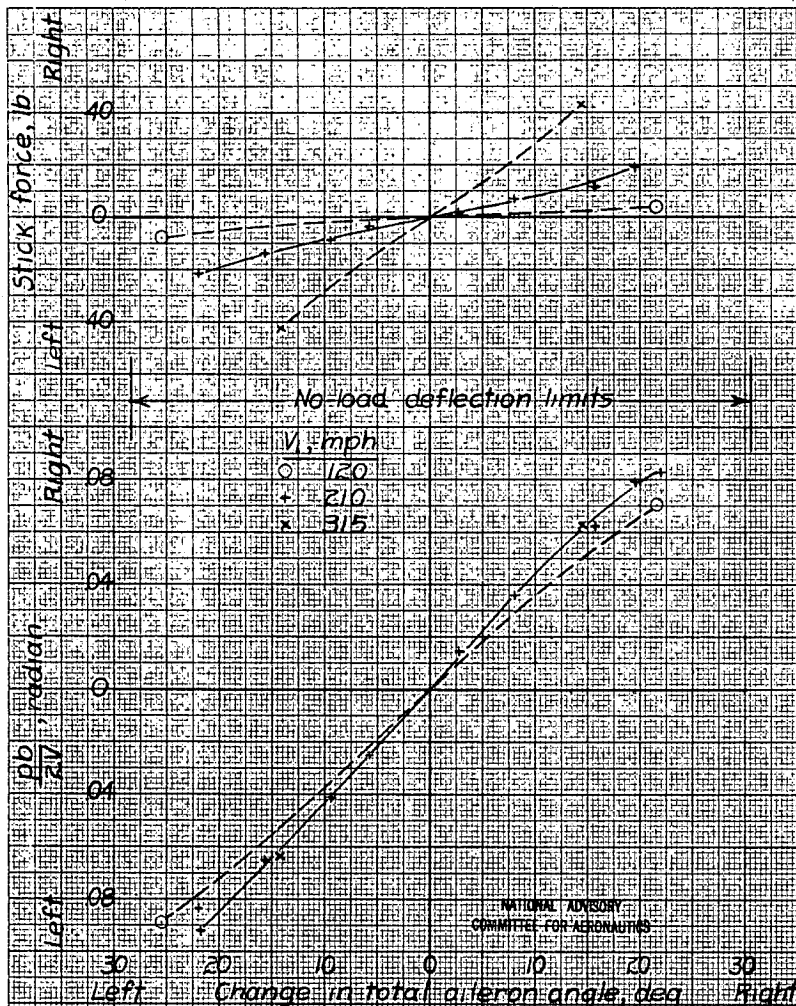

Figure 8.- Aileron stick forces and wing-tip helix angles plotted against estimated true change in total aileron angle. Bell P-63A-1 airplane, power for level flight, clean condition.

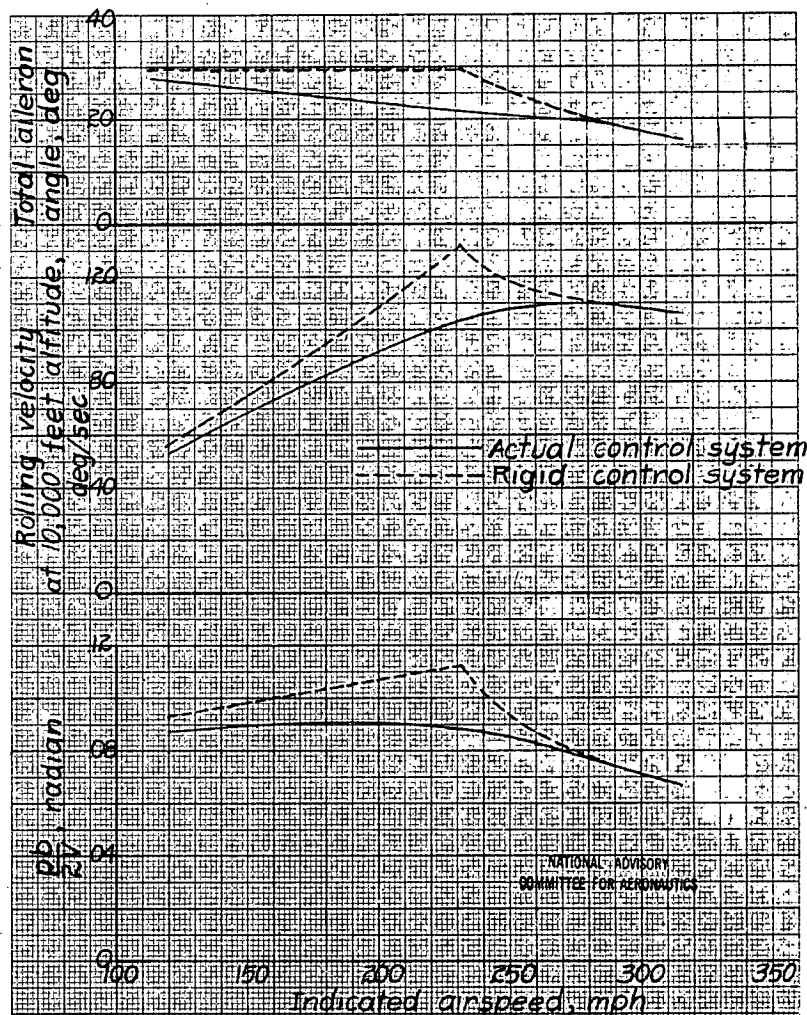

Figure 9.- Estimated average rolling performance of Bell P-63A-1 airplane with 50 pound stick force.

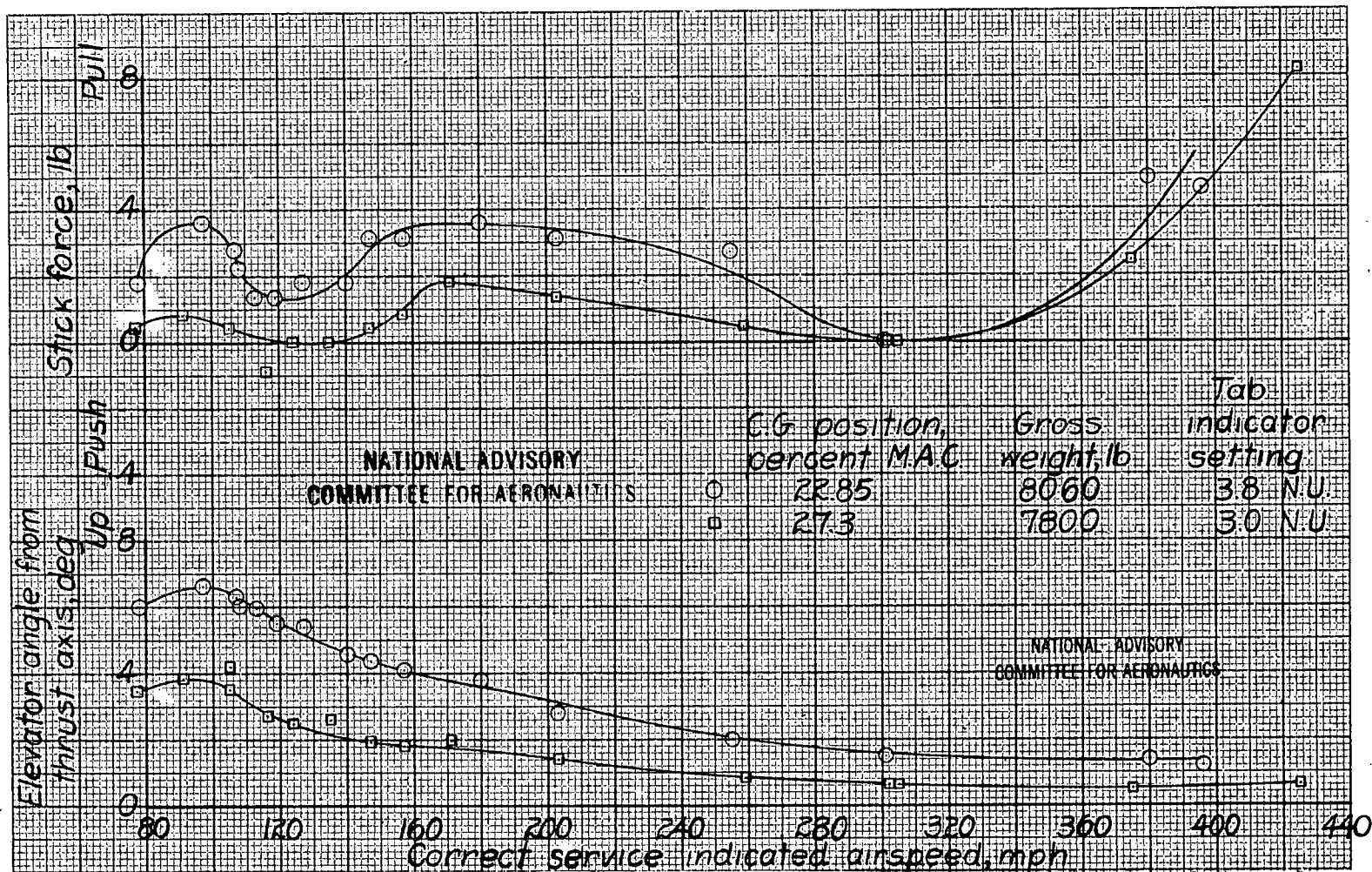

Figure 10.- Variation of stick force and elevator angle required to trim the Bell P-63A-1 airplane in straight flight plotted as a function of indicated airspeed for two center-of-gravity positions. Normal rated power at 10,000 feet (2600 RPM, 43 in. Hg), all cooling shutters locked in closed position, flaps and gear retracted.



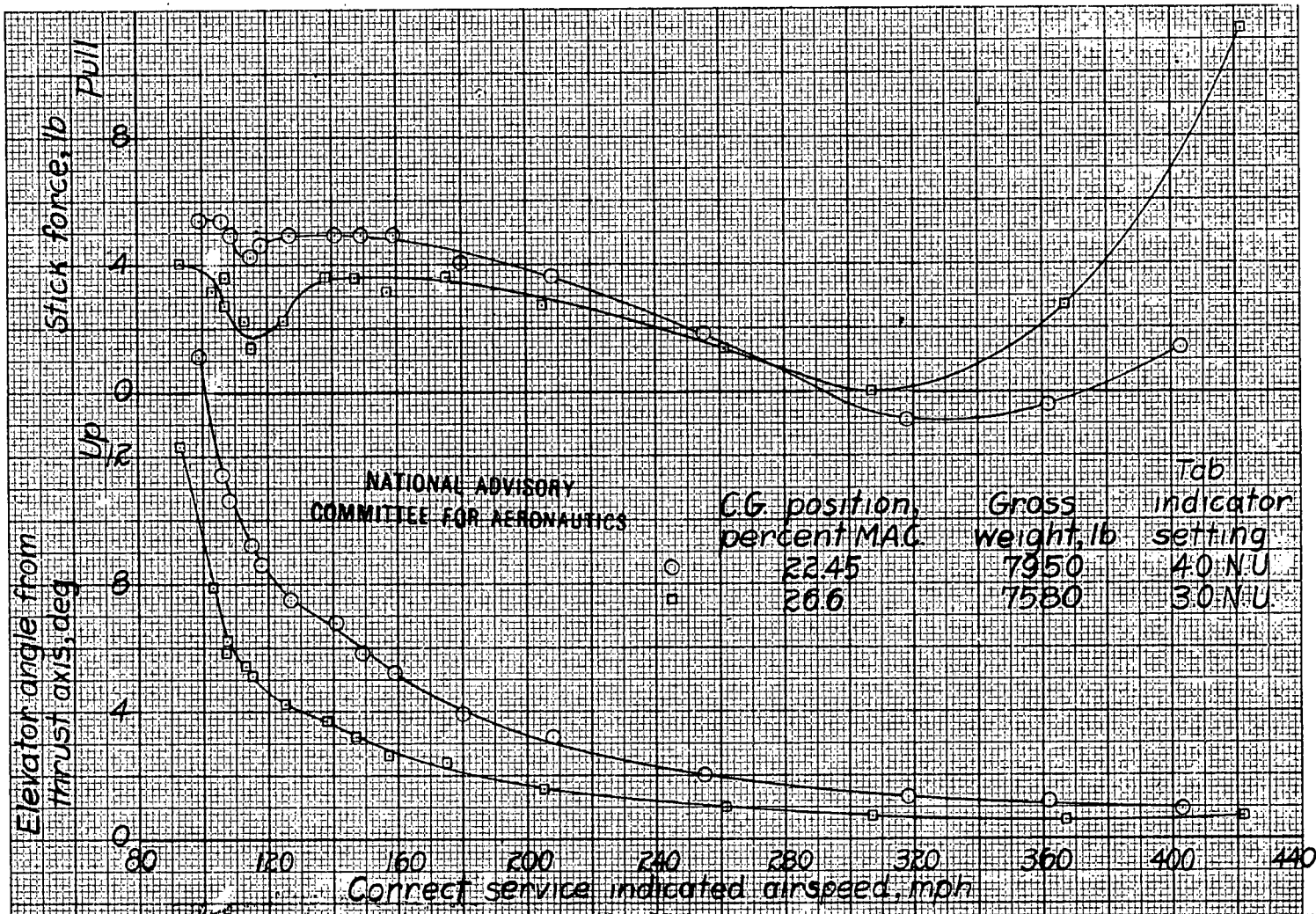

Figure 11.- Variation of stick force and elevator angle required to trim the Bell P-63A-1 airplane in straight flight plotted as a function of indicated airspeed for two center-of-gravity positions. Engine idling; all cooling shutters locked in closed position, flaps and gear retracted.

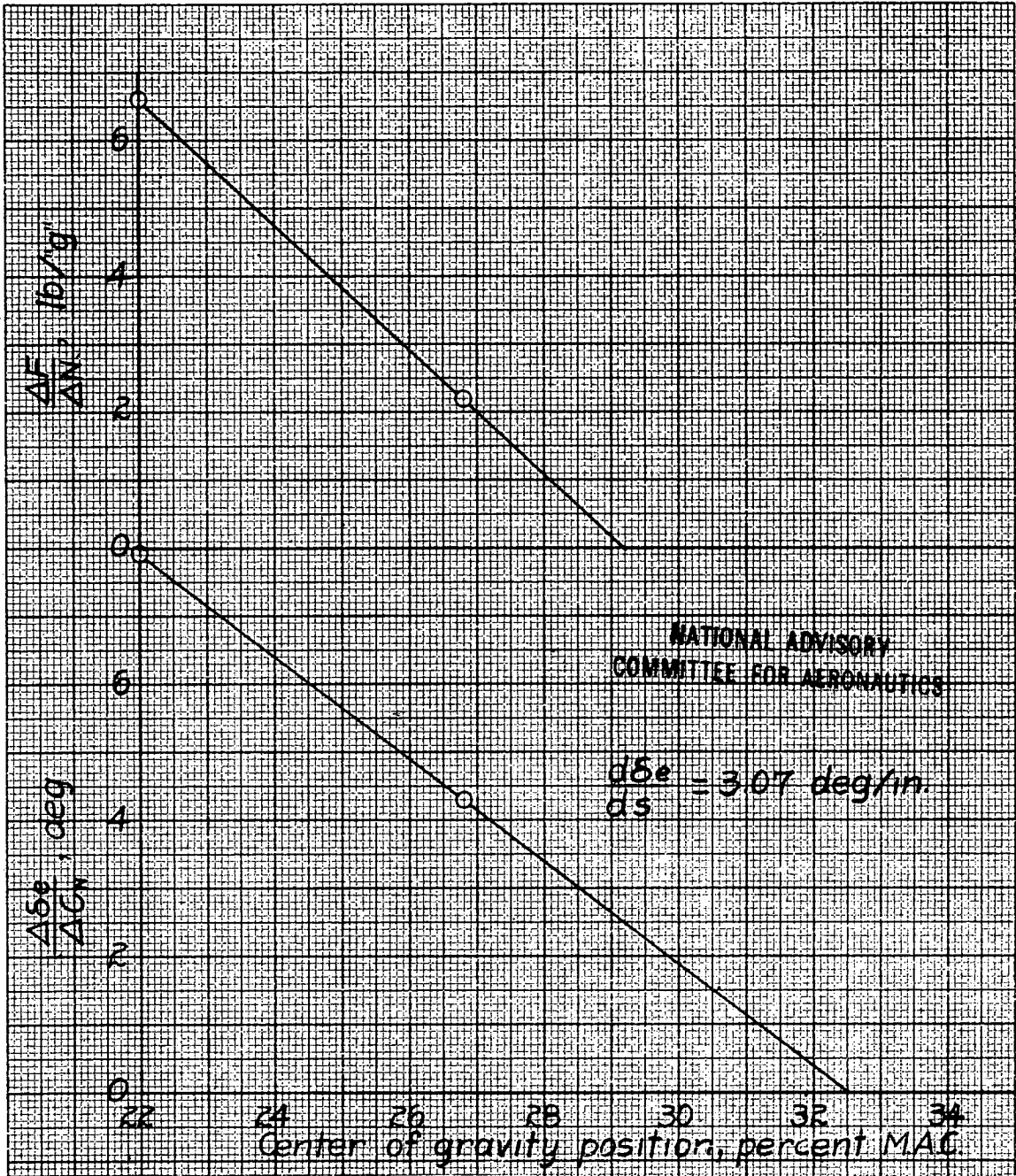

Figure 12.- Summary of the longitudinal stability and control characteristics of an original P-63A-1 airplane (AAF No. 42-68861) in steady turning flight with normal rated power at 10,000 feet altitude (2600 RPM, 43 in. Hg). Clean condition, all cooling shutters locked in closed position.

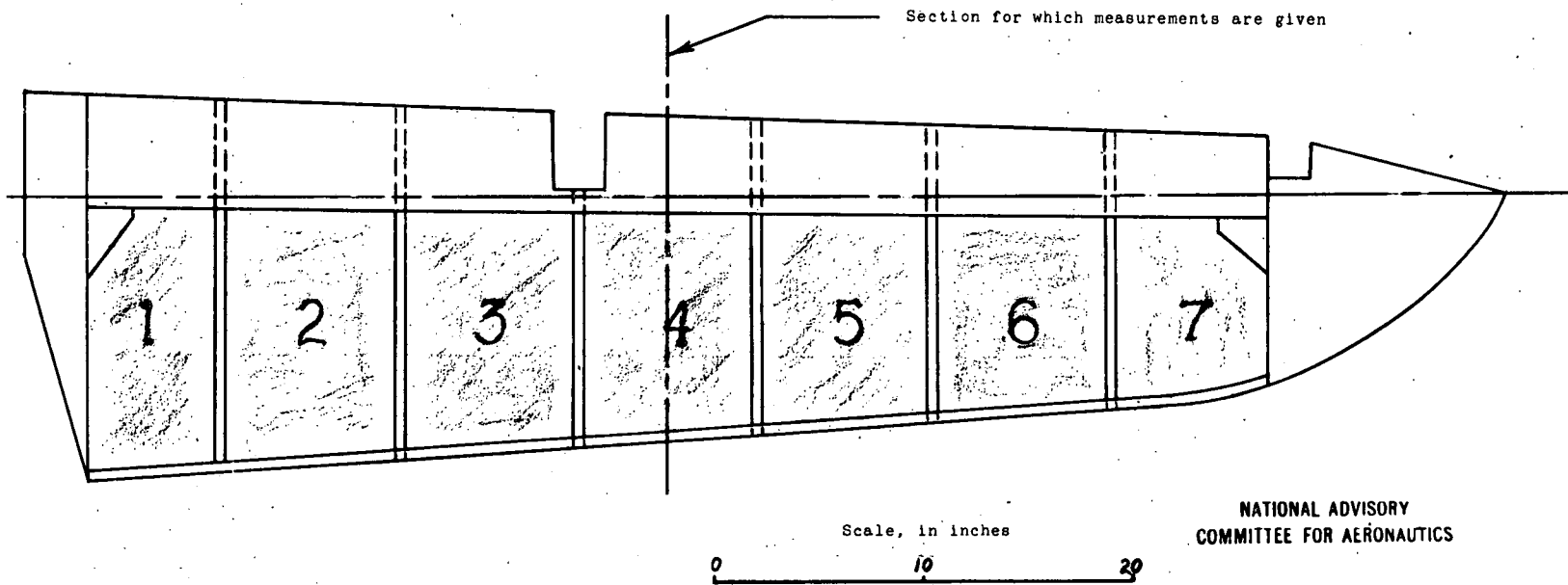
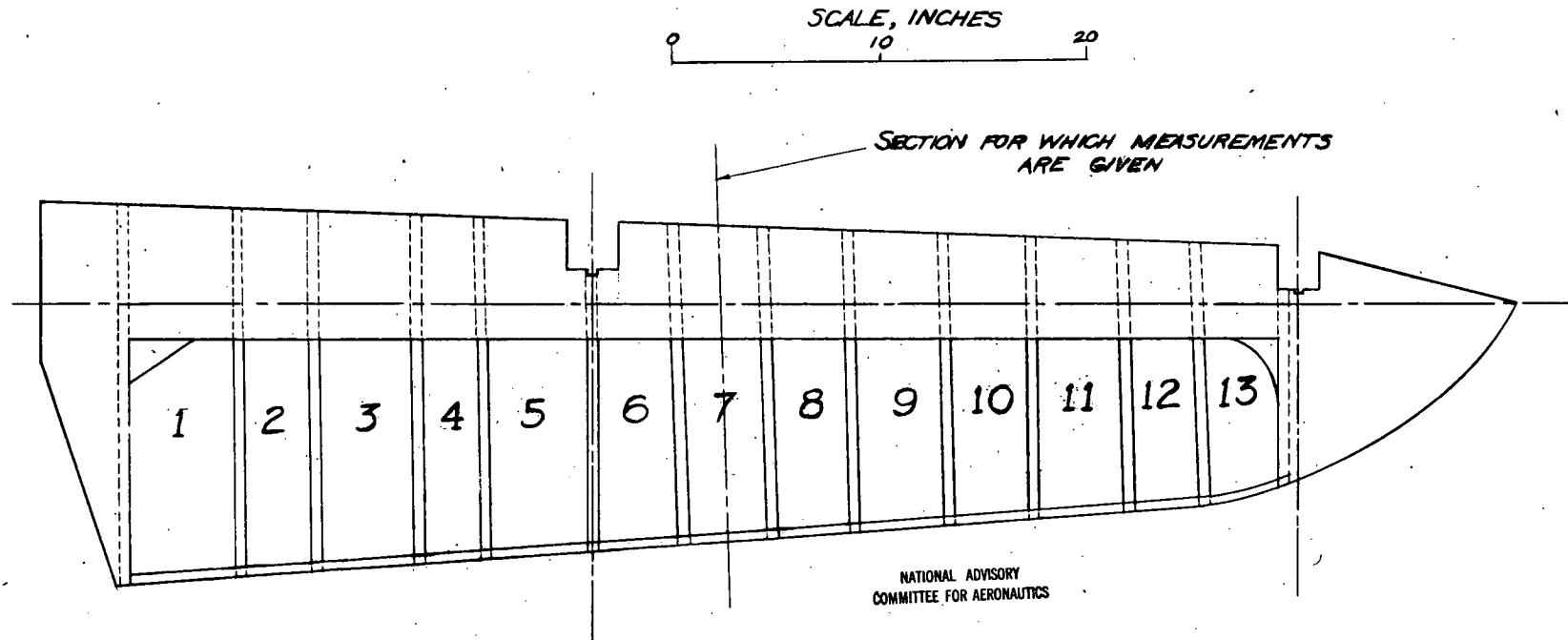

Figure 13.- Planform of P-63A-1 normal short-chord elevator showing rib locations and extent of unsupported fabric panels.





*FIGURE 1A.-PLANFORM OF P-63A-1  
NORMAL SHORT-CHORD HALF RIB-SPACED  
ELEVATOR SHOWING RIB LOCATIONS AND  
POSITIONS OF UNSUPPORTED FABRIC  
PANELS.*

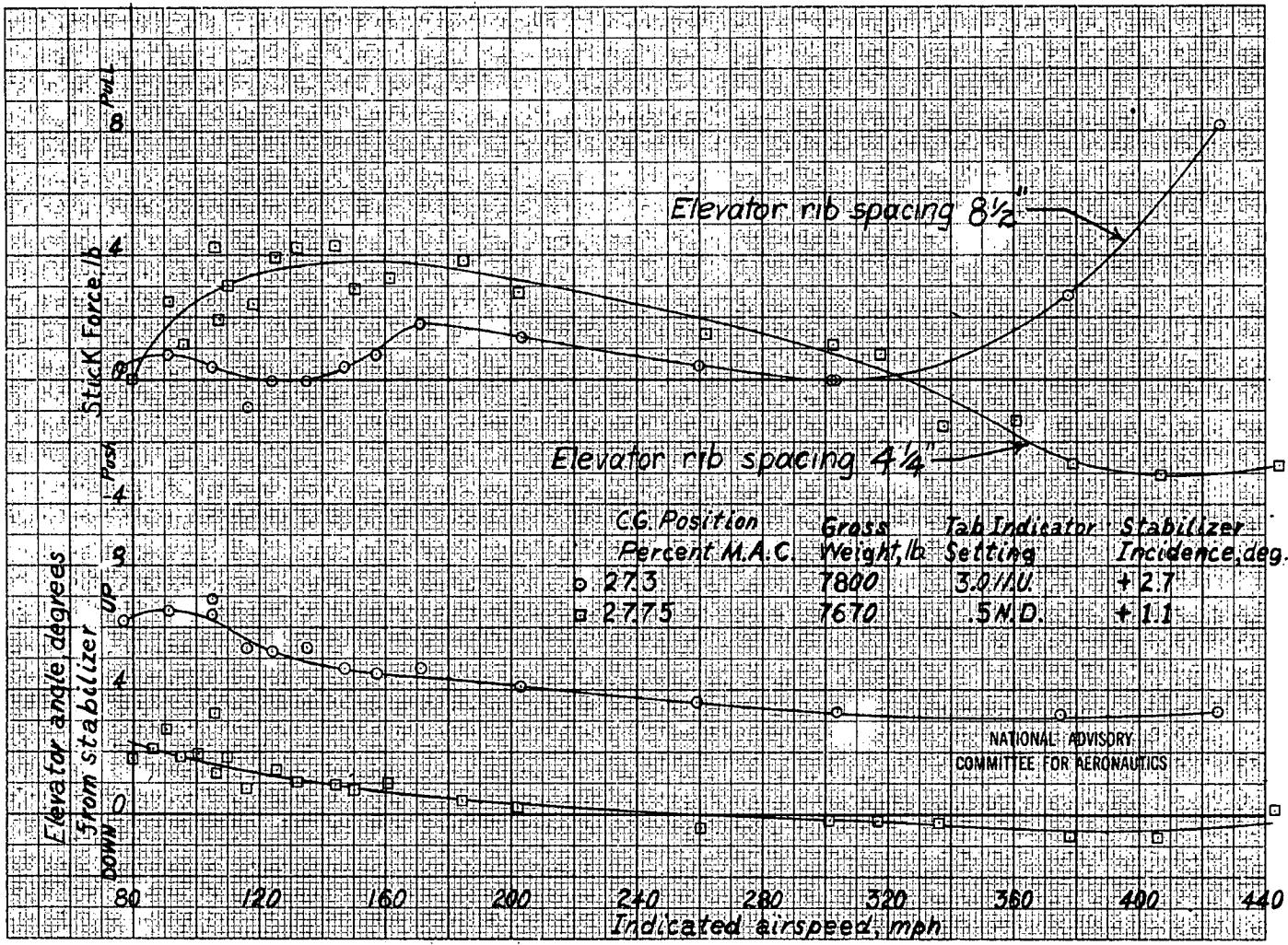
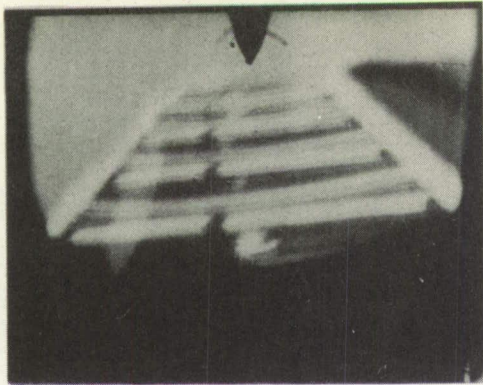
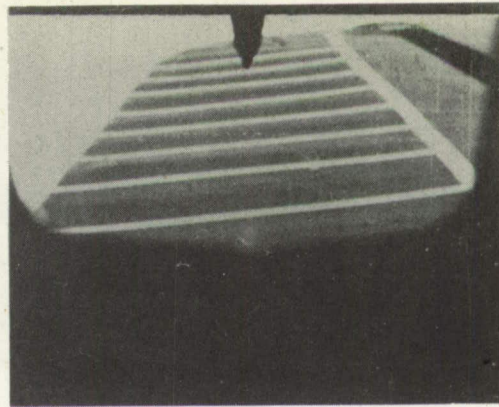

Figure 15.- Data showing the effect of stabilizer incidence setting and stiffness of elevator fabric covering on the static longitudinal stability characteristics of a P-63A-1 airplane (AAF No. 42-68889). Clean condition, normal rated power (2600 RPM, 43 in. Hg), altitude range 5-10,000 feet.



(a) Upper Surface



(b) Upper Surface

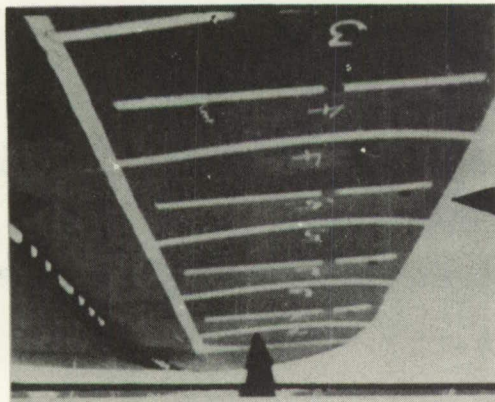

(a) Lower Surface

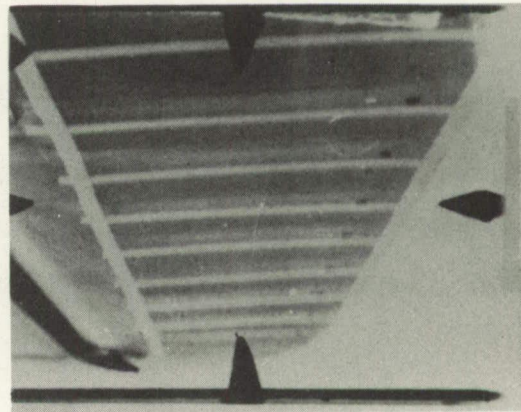

(b) Lower Surface

Figure 16.- Examples of photographs taken to investigate the effects of elevator fabric distortion.

(a) Original P-63A-1 elevator in straight flight at  $V_i = 350$  MPH. Elevator rib spacing  $8 \frac{1}{4}$  inches.

(b) Stiffened P-63A-1 elevator in straight flight at  $V_i = 350$  MPH. Elevator rib spacing  $4 \frac{1}{4}$  inches.

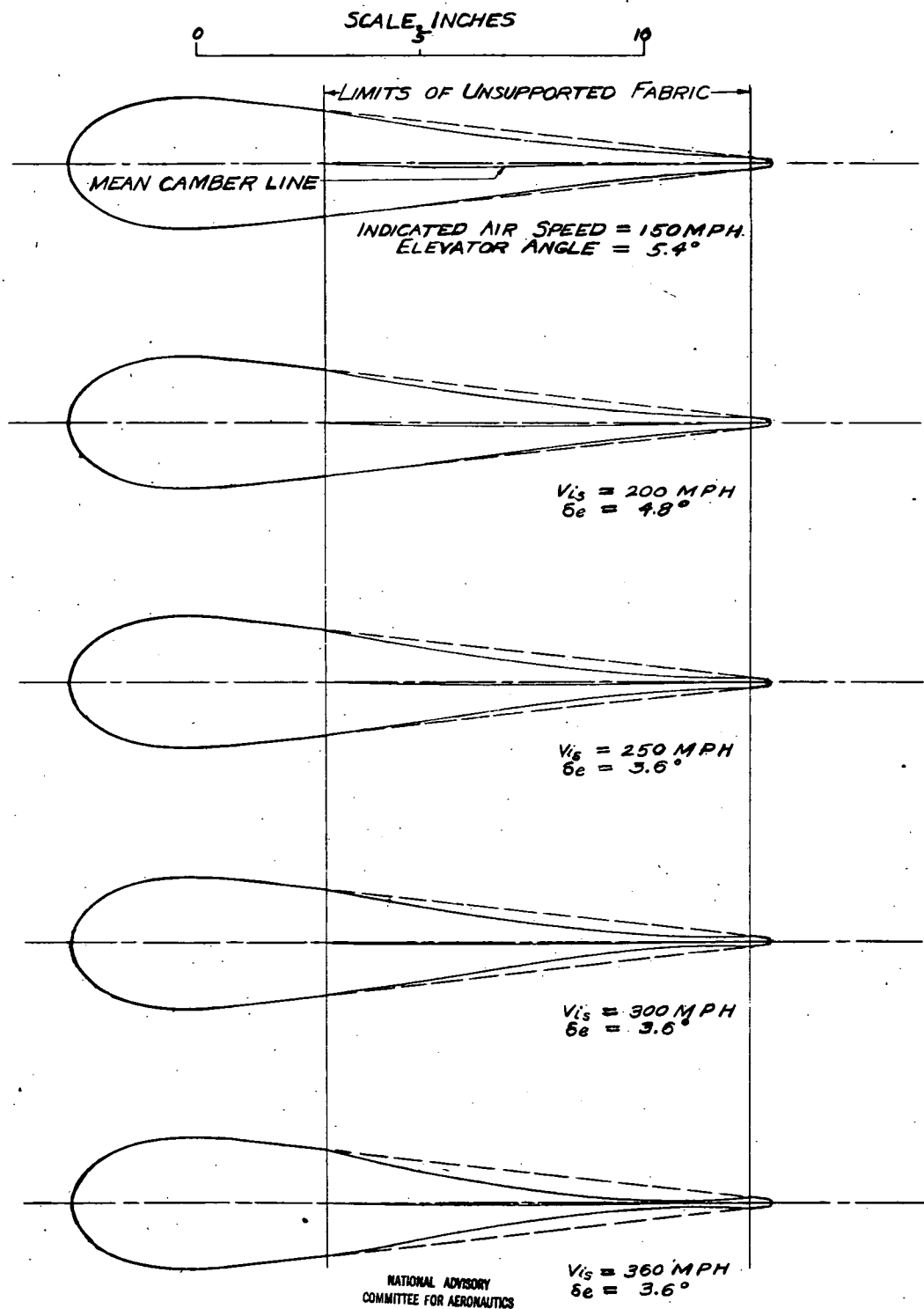

FIGURE 17.- ELEVATOR SECTIONS AT CENTER OF PANEL NUMBER 4 (FIGURE 13) SHOWING THE VARIATION OF FABRIC DEFLECTION WITH INDICATED AIRSPEED AT AN ACCELERATION OF  $1g$ . ELEVATOR ANGLES ARE GIVEN WITH RESPECT TO STABILIZER. (+ = UP); STABILIZER INCIDENCE  $2.7^\circ$  ELEVATOR RIB SPACING  $8\frac{1}{2}$  INCHES.

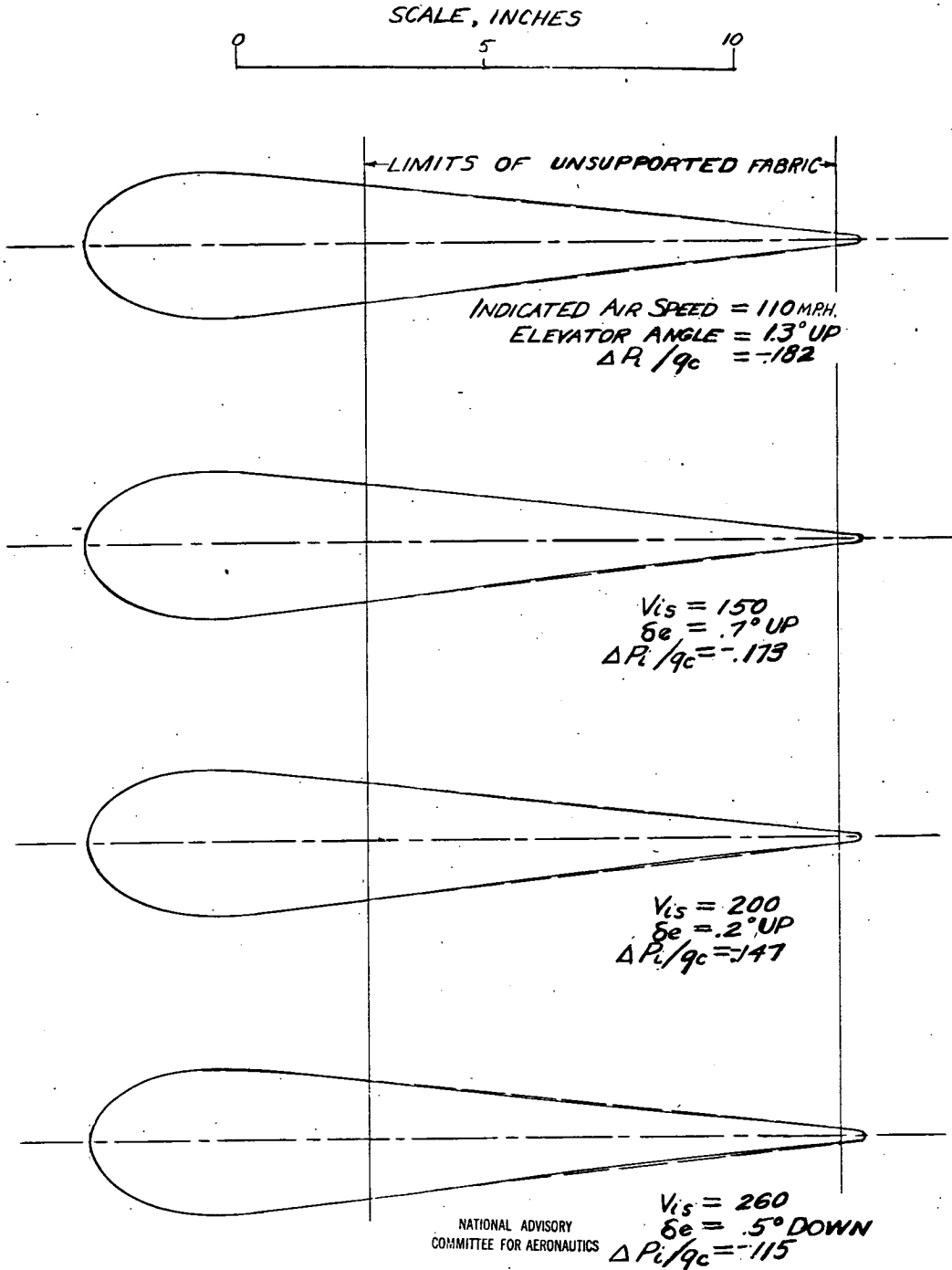

FIGURE 18.- ELEVATOR SECTIONS AT CENTER OF PANEL NUMBER 7 (FIGURE 1A) SHOWING THE VARIATION OF FABRIC DEFLECTION WITH INDICATED AIRSPEED IN STRAIGHT FLIGHT. ELEVATOR ANGLES ARE GIVEN WITH RESPECT TO STABILIZER. STABILIZER INCIDENCE +1.1°. ELEVATOR INTERNAL PRESSURE MEASURED AT PANEL NUMBER 7 IS GIVEN AS FRACTION OF CORRECT IMPACT PRESSURE BELOW CORRECT STATIC PRESSURE. ELEVATOR RIB SPACING 4 1/4 INCHES.

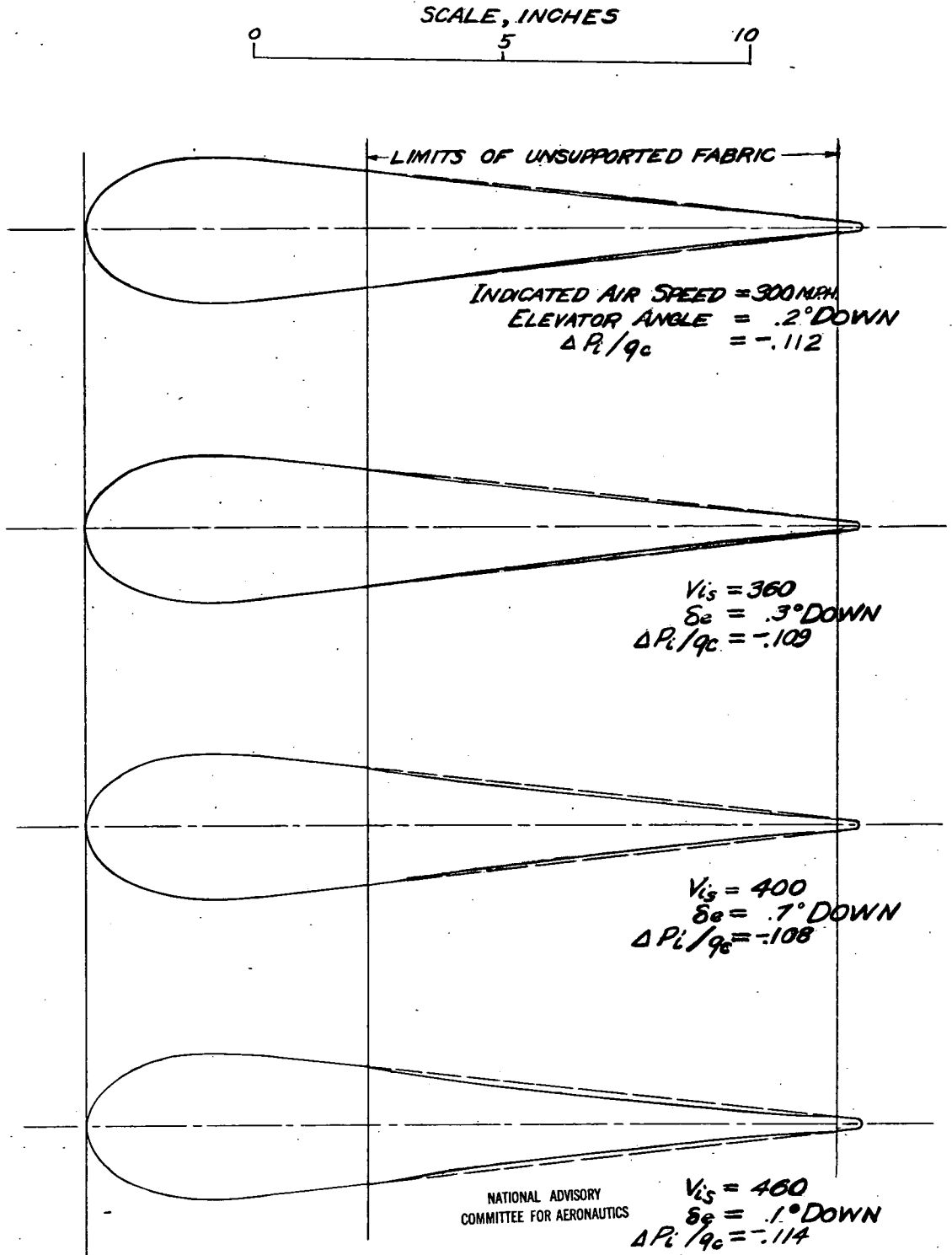

FIGURE 18.- CONCLUDED



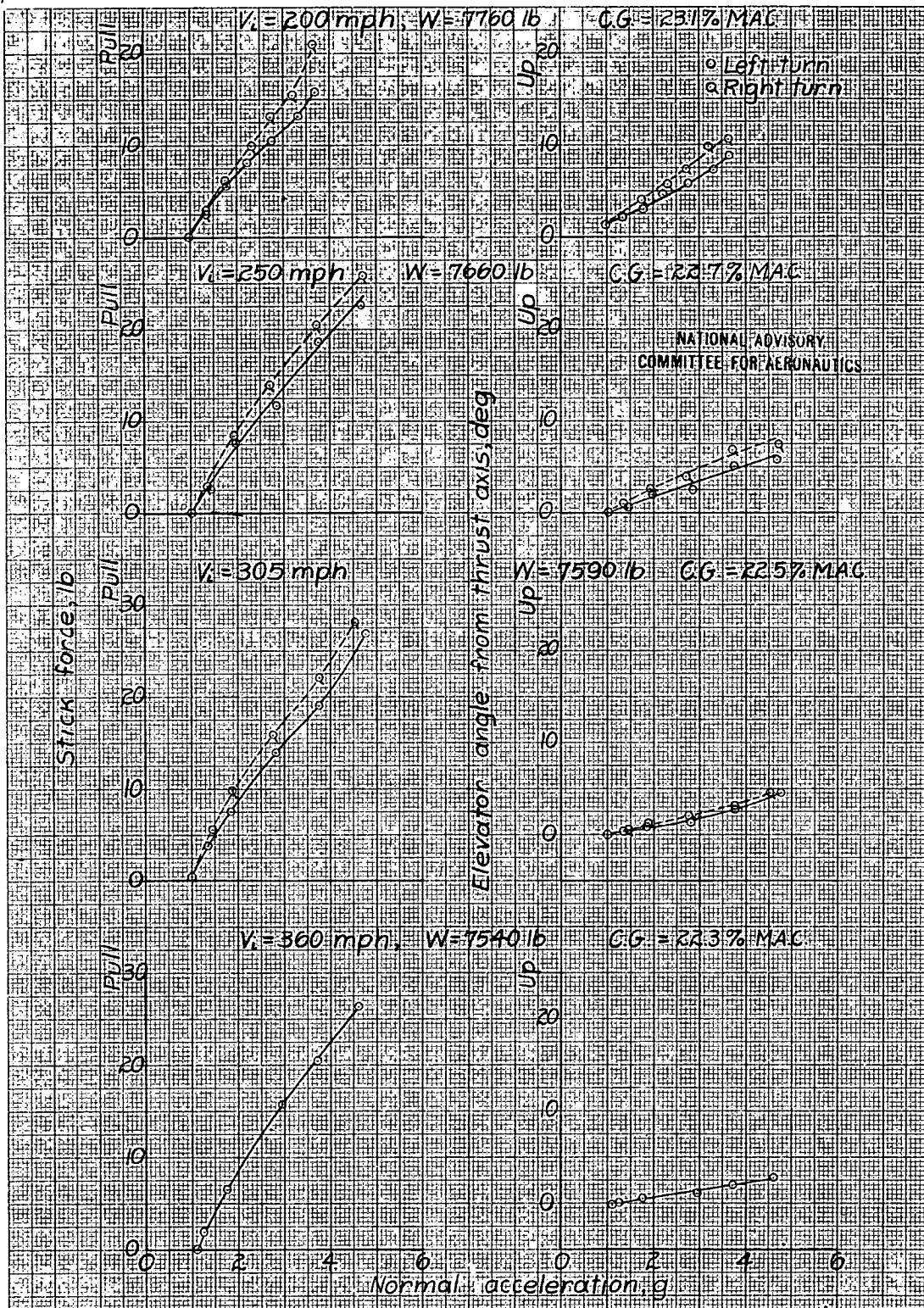

Figure 19.- Variation of stick force and elevator angle required to trim in turning flight with normal acceleration for various service indicated airspeeds. Bell P-63A-1 airplane, normal short-chord half rib-spaced elevators, stabilizer incidence +1.1°. Clean condition, normal rated power (2600 rpm, 43 in. Hg), coolant shutters closed, altitude approximately 5000 feet.

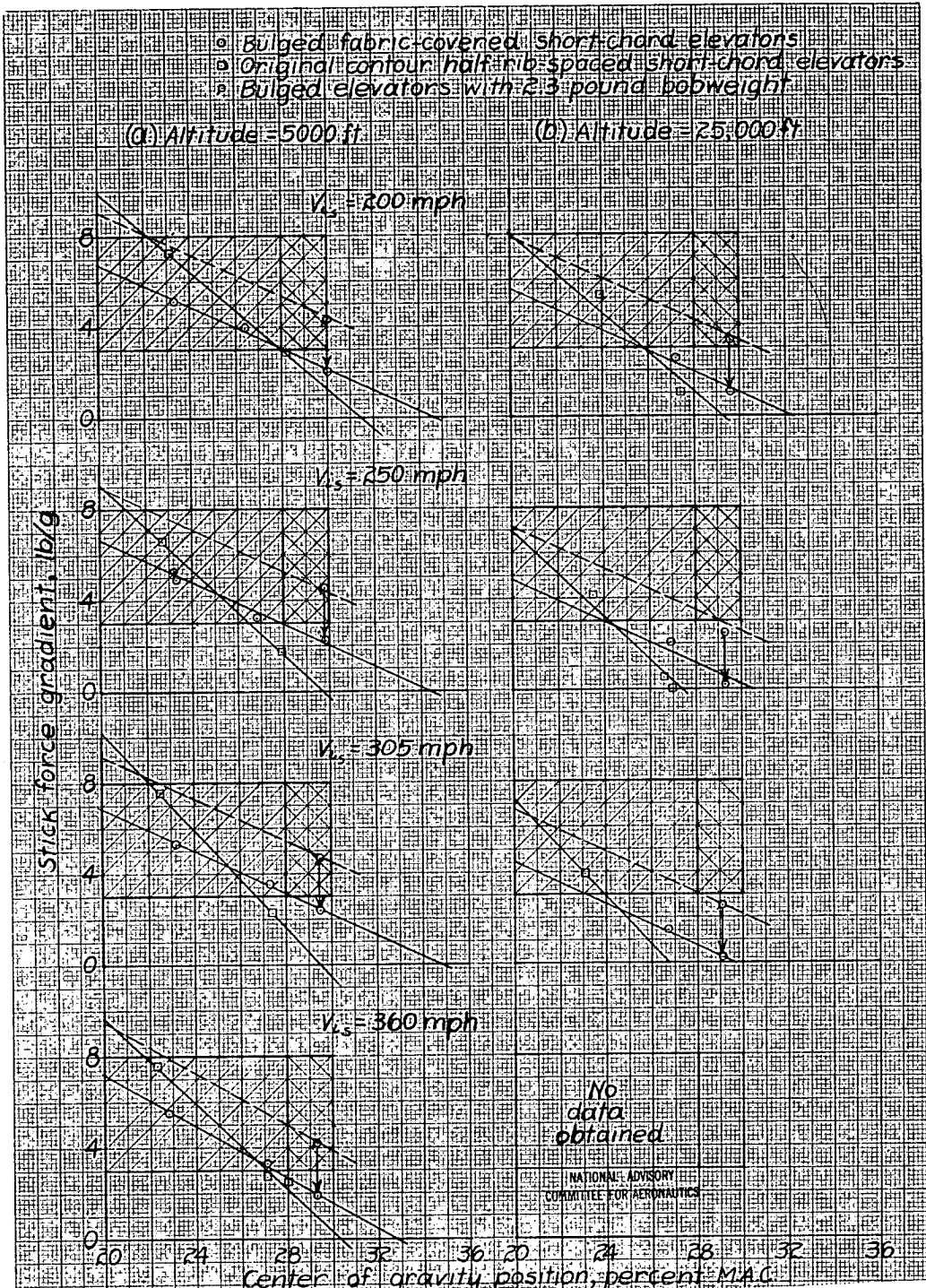

Figure 20.- Summary of the stick-free maneuvering characteristics of the P-63A-1 airplane with bulged fabric-covered short-chord elevators having 9 inches trailing edge strips, elevator-stabilizer gap =  $\frac{1}{8}$  inch and with original contour half rib-spaced fabric-covered short-chord elevators for (a) 5000 feet altitude and, (b) 25,000 feet altitude. Clean condition, power on, stabilizer incidence  $+1.1^\circ$ .



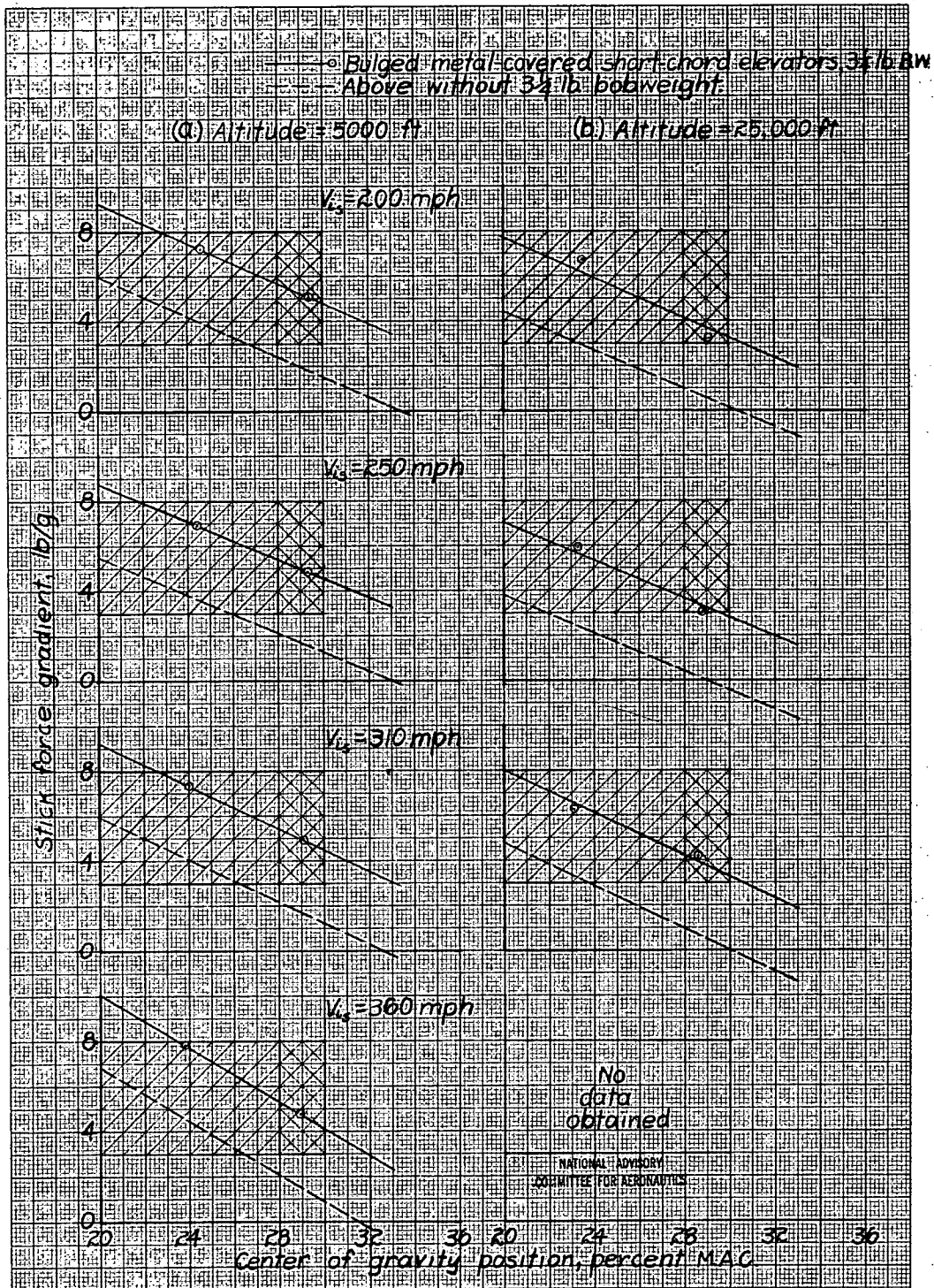

Figure 21.- Summary of the stick-free maneuvering characteristics of the P-63A-1 airplane with bulged metal-covered short-chord elevators having an average trailing edge angle of  $17.0^\circ$  and with the elevator-stabilizer gap reduced to about  $\frac{1}{8}$  inch for (a) 5000 feet altitude, and (b) 25,000 feet altitude. Clean condition, power on, stabilizer incidence  $+1.1^\circ$ .

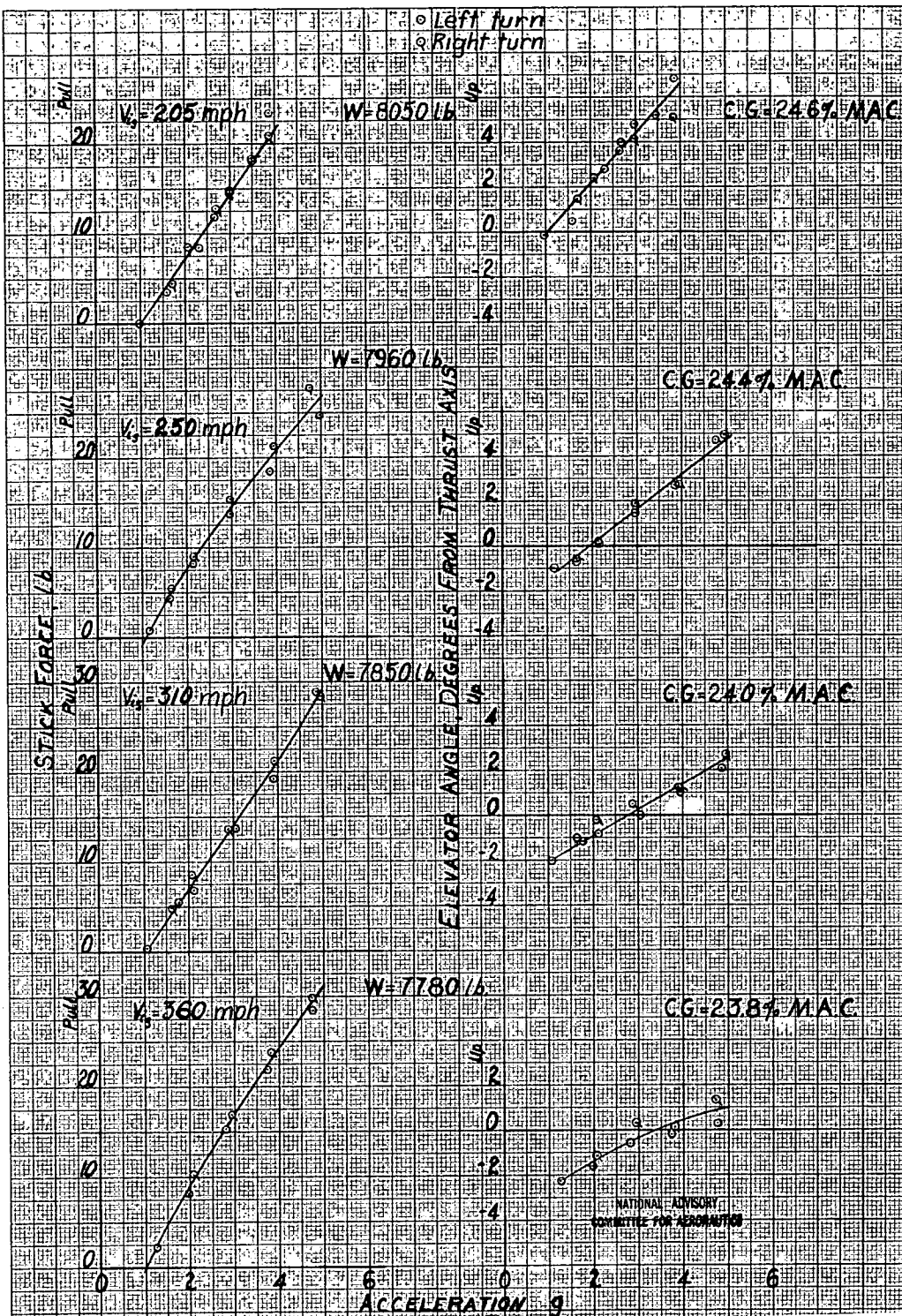

Figure 22.- Variation of stick force and elevator angle required to trim in turning flight with normal acceleration for various service indicated airspeeds. Bell P-63A-1 airplane, bulged metal-covered short-chord elevators with  $3\frac{1}{4}$  pound bobweight,  $\frac{1}{8}$  inch elevator-stabilizer gap, stabilizer incidence  $\pm 1.1^\circ$ . Clean condition, normal rated power (2600 RPM, 43 in. Hg), coolant shutters closed, altitude approximately 5000 feet.

NATIONAL ADVISORY  
 COMMITTEE FOR AERONAUTICS

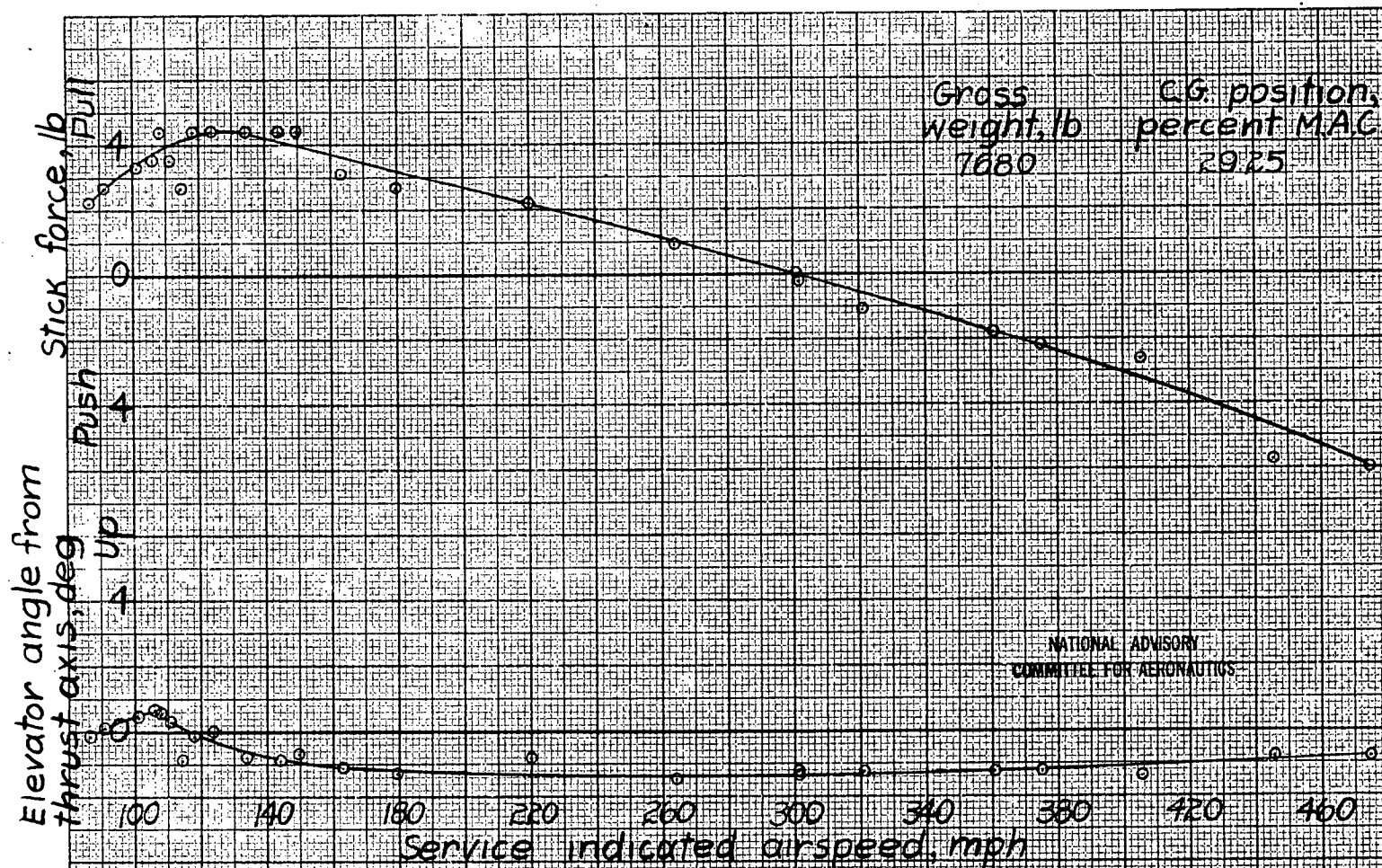

Figure 23.- Variation with service indicated airspeed of stick force and elevator angle required to trim in straight flight. Bell P-63A-1 airplane, bulged metal-covered short-chord elevators with  $3\frac{1}{4}$  pound bobweight,  $\frac{1}{8}$  inch elevator-stabilizer gap, stabilizer incidence  $+1.1^\circ$ . Clean condition, normal rated power (2600 RPM, 43 in. Hg), coolant shutters closed, altitude approximately 5000 feet.

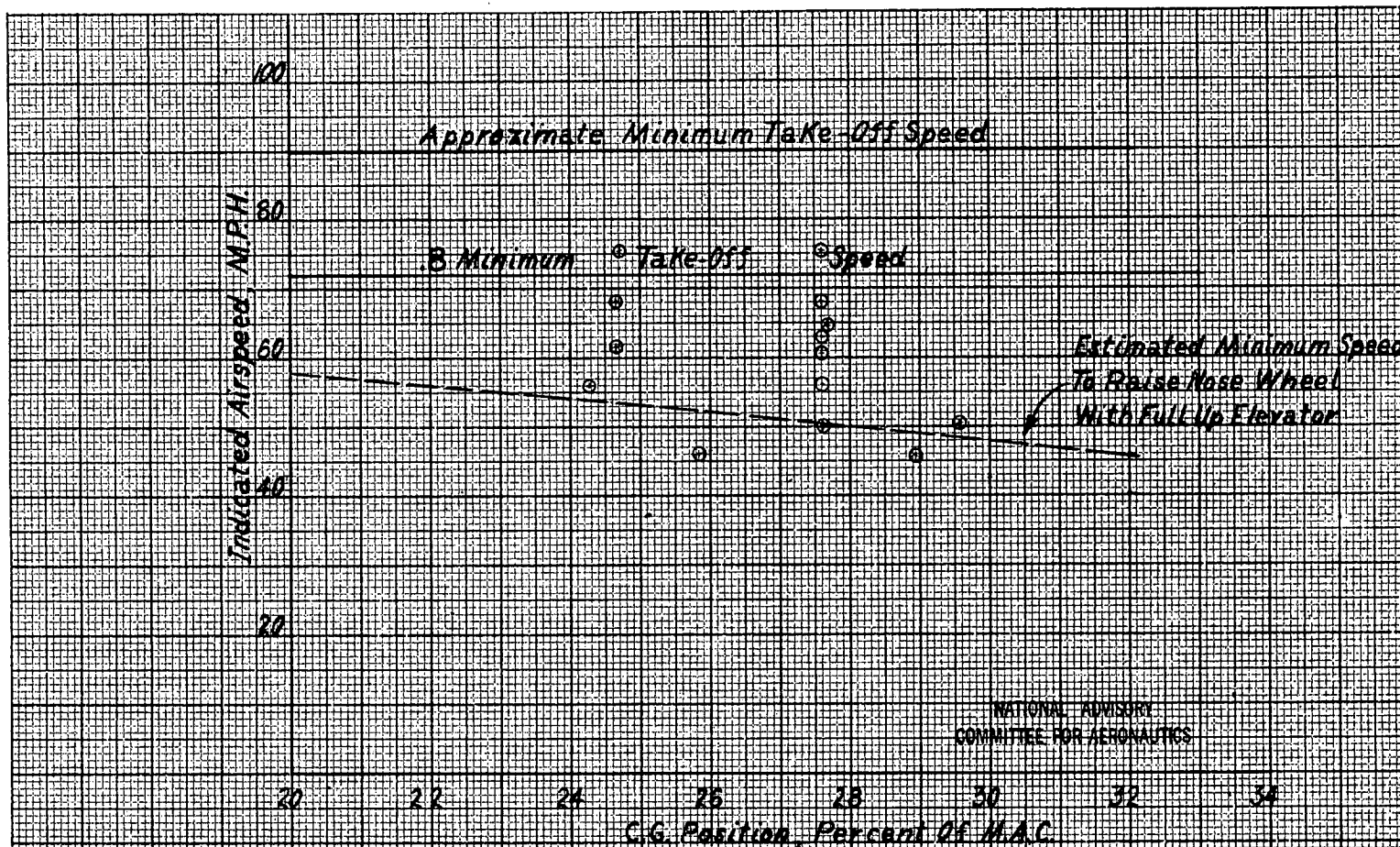

Figure 24.- Data showing speeds at which nose wheel was raised from concrete runway during take-off using various amounts of up-elevator deflection. Faired curve is estimated variation of minimum speed with full-up elevator deflection. Bell P-63A-1 airplane, horizontal tail planform shown in Figure 4B, various different elevators installed.



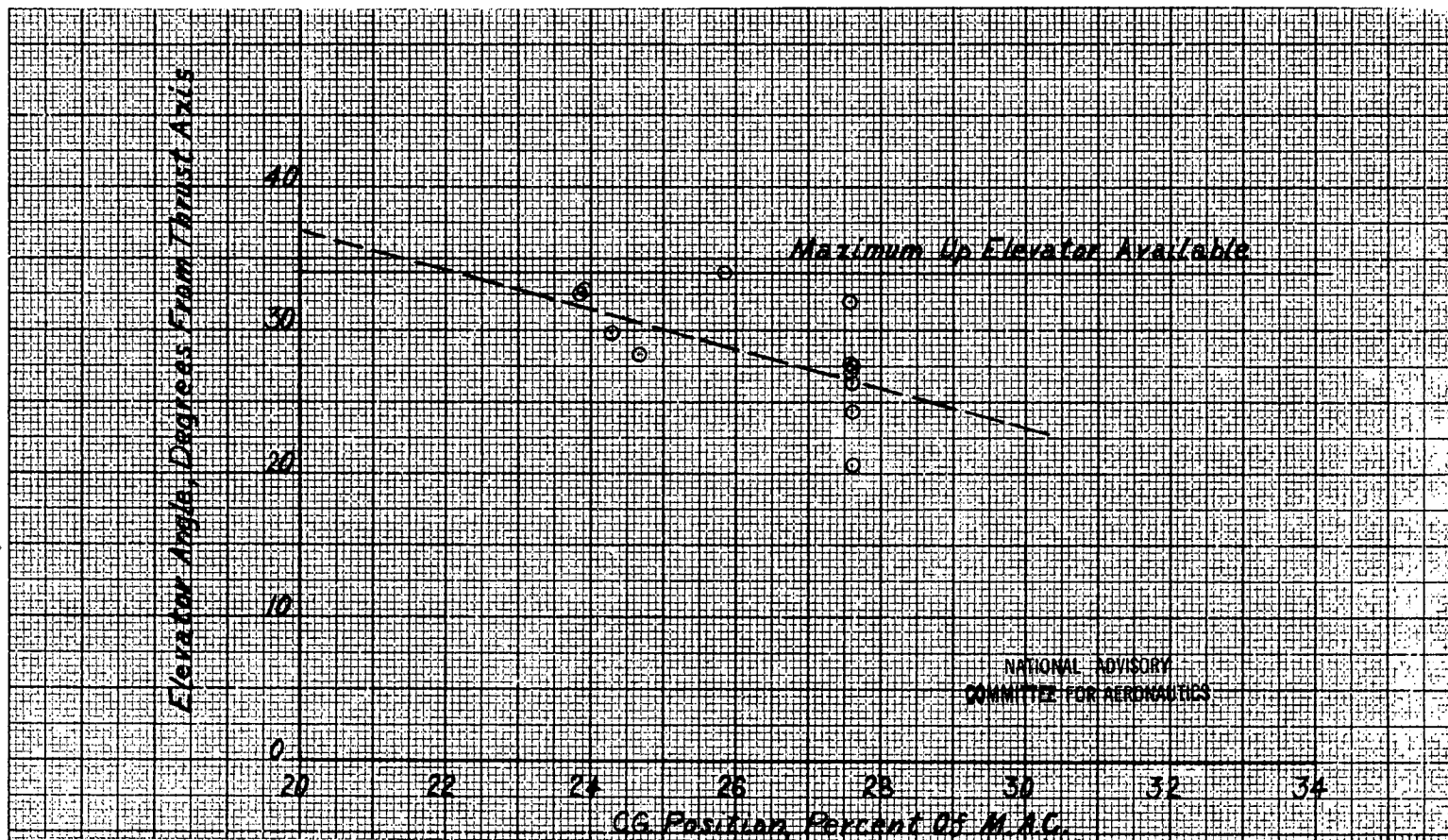

Figure 25.- Data showing the amount of elevator control necessary to make minimum speed landings with power off and landing flaps full down. Bell P-63A-1 airplane, horizontal tail planform shown in Figure 4B, various different elevators installed.

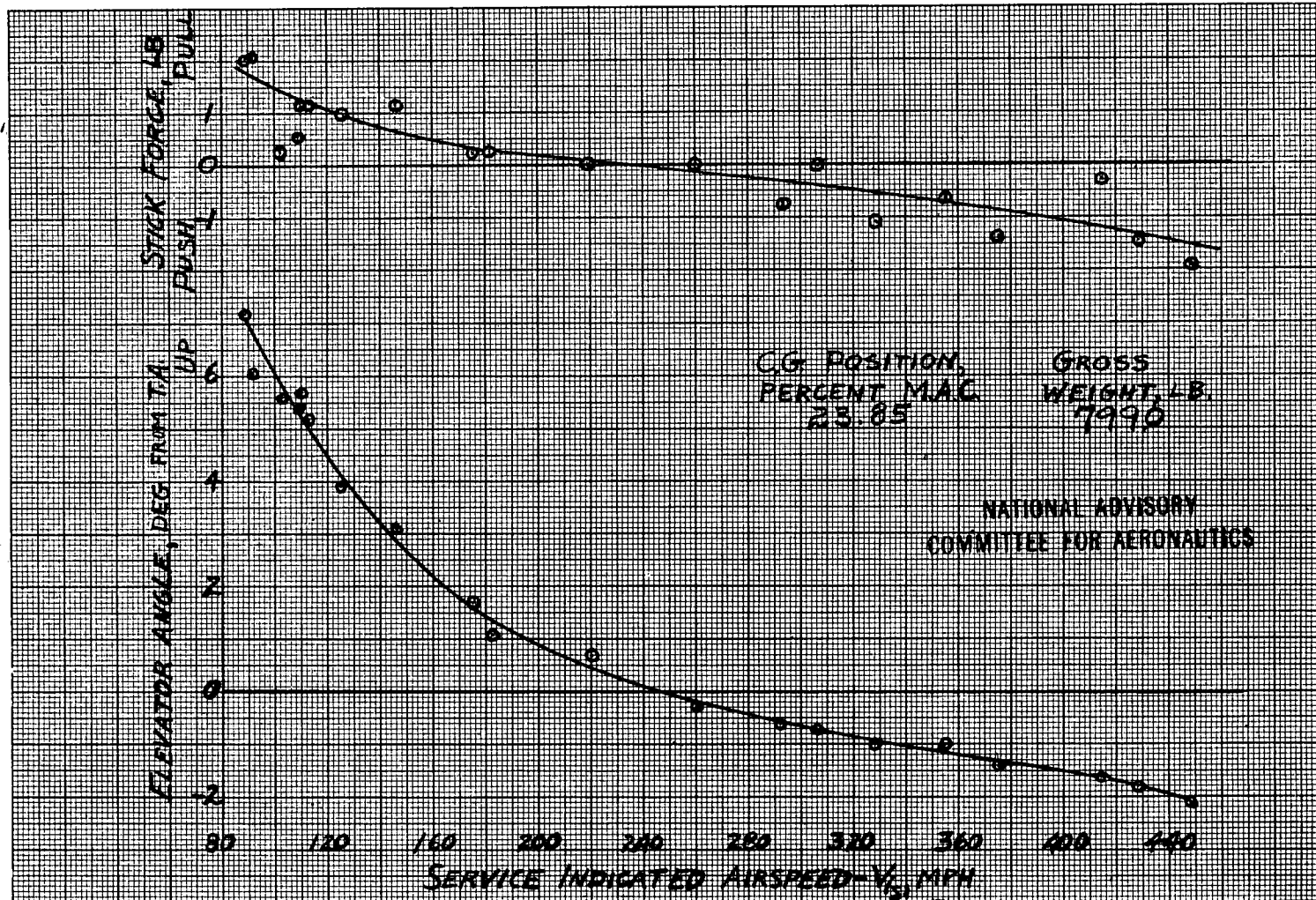

Figure 26.- Variation with indicated airspeed of stick force and elevator angle required to trim a Bell P-63A-1 airplane in straight flight. Horizontal tail shown in Figure 4C, bulged fabric-covered elevator shown in Figure 5D, elevator-stabilizer gap unsealed. Clean condition, normal rated power (2600 RPM, 43 in. Hg), altitude 5000 feet.



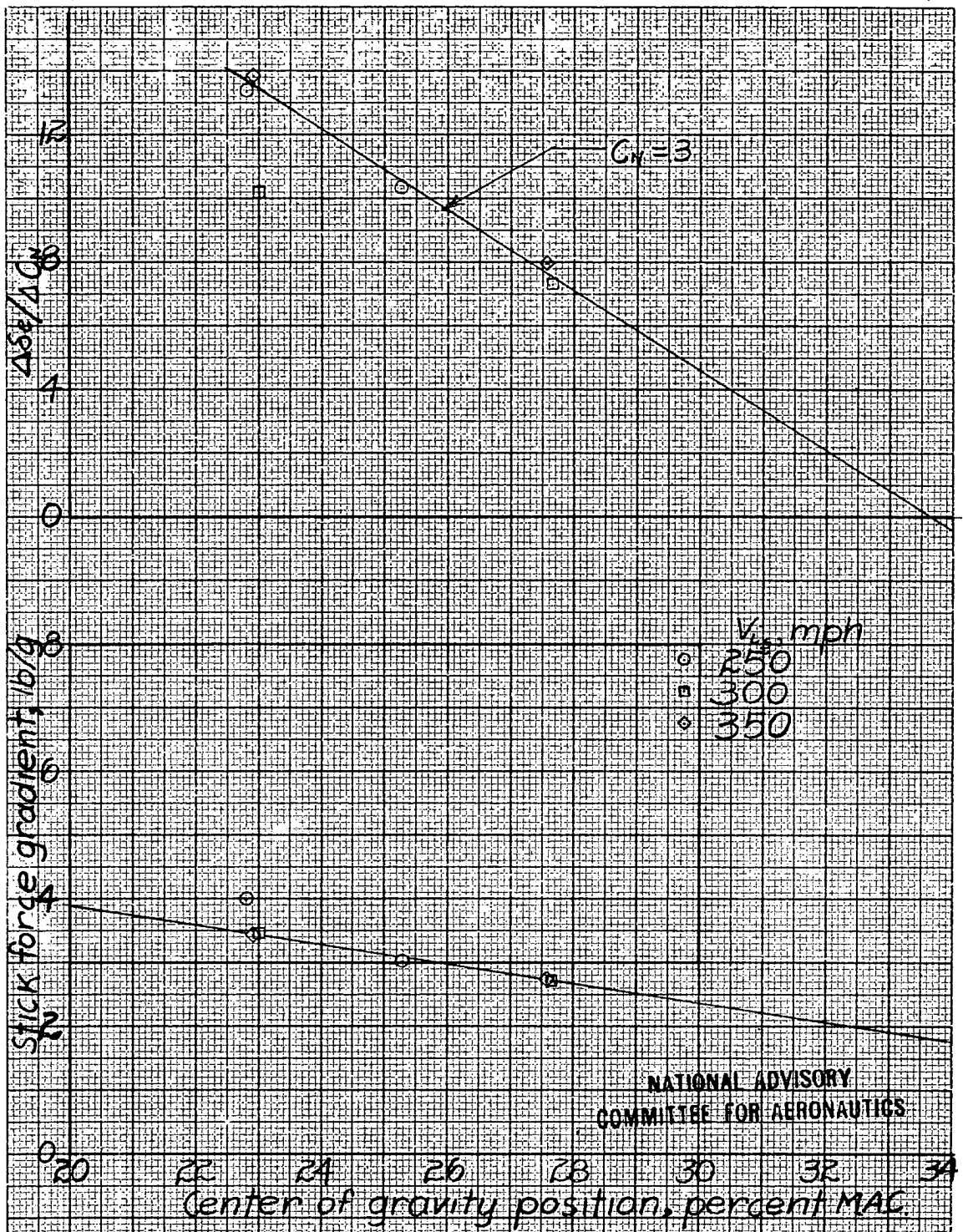

Figure 27.- Summary of the longitudinal stability characteristics of the Bell P-63A-1 airplane in steady, turning flight. Enlarged horizontal tail shown in figure 4C, bulged fabric-covered elevators shown in figure 5D, elevator stabilizer gap unsealed. Clean condition, normal rated power (2600 RPM, 43 in. Hg), altitude 5000 feet.

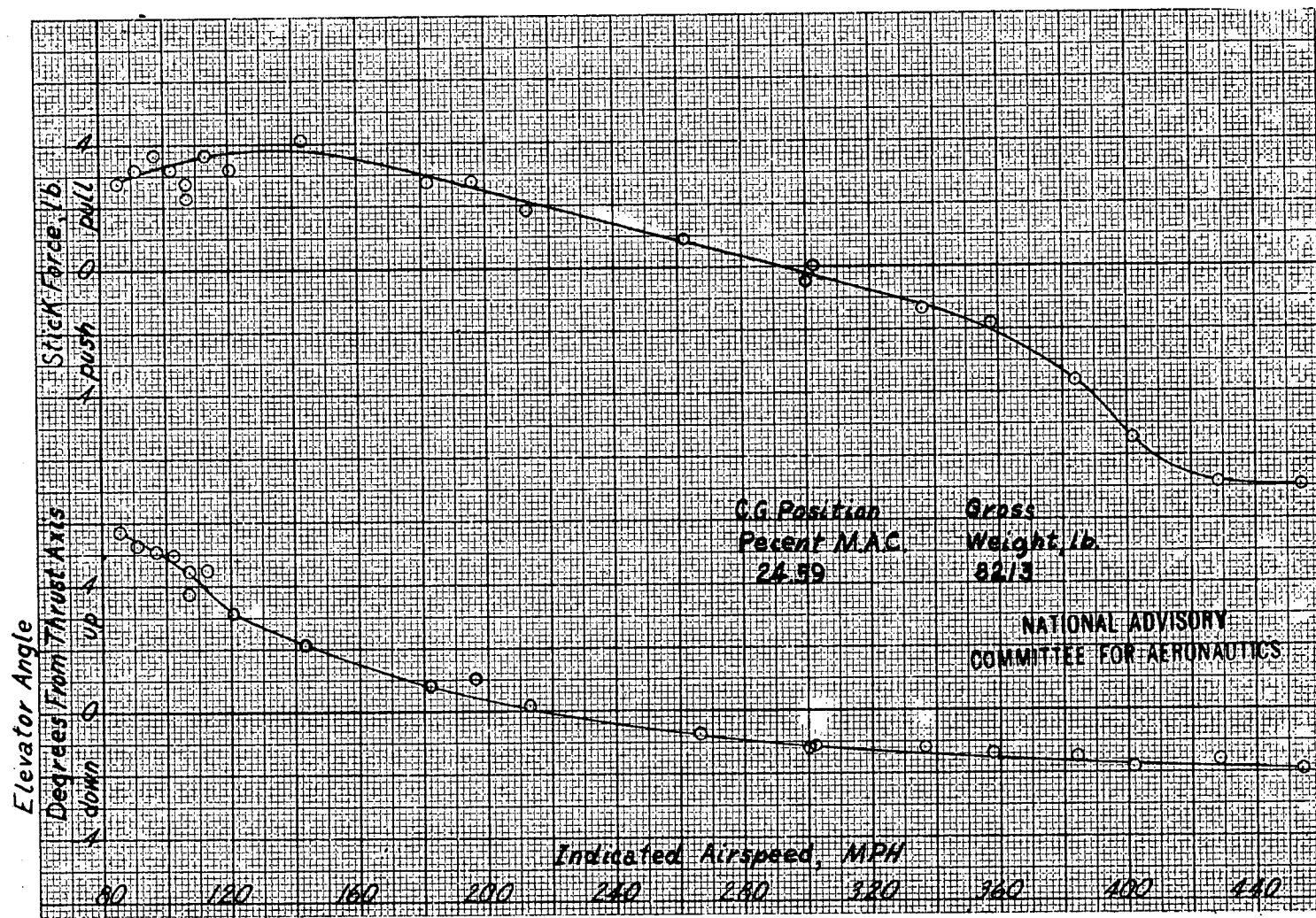

Figure 28.- Variation with indicated airspeed of stick force and elevator angle required to trim a Bell P-63A-1 airplane in straight flight. Horizontal tail shown in Figure 4C, bulged fabric-covered elevators shown in Figure 5D, elevator-stabilizer gap sealed. Clean condition, normal rated power (2600 RPM, 43 in. Hg), altitude 5000 feet.

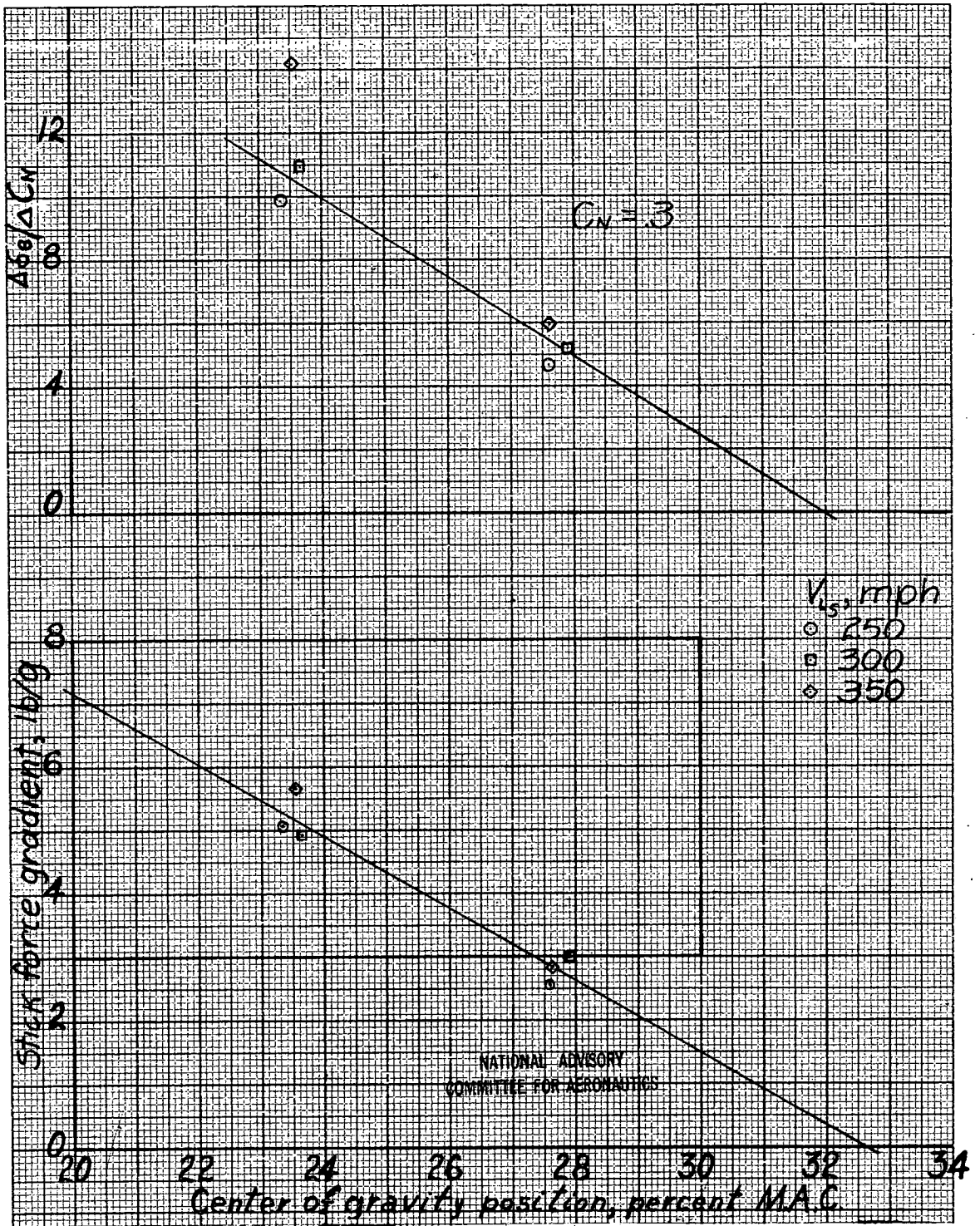

Figure 29.- Summary of the longitudinal stability characteristics of the Bell P-63A-1 airplane in steady turning flight. Enlarged horizontal tail shown in Figure 4C, bulged fabric-covered elevators shown in Figure 5D, elevator-stabilizer gap sealed. Clean condition, normal rated power (2600 RPM, 43 in Hg), altitude 5000 feet.

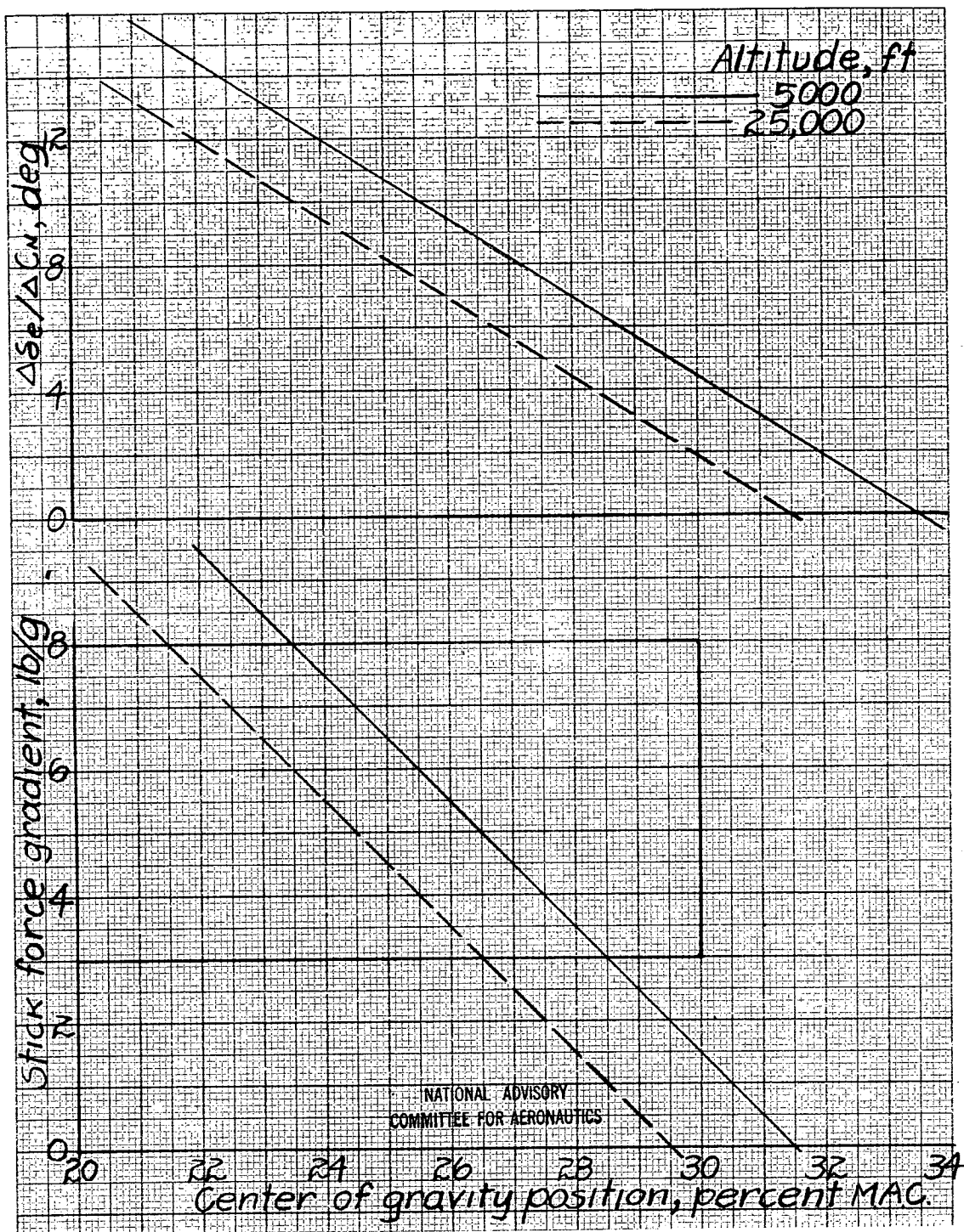

Figure 30.- Predicted longitudinal stability characteristics for steady turning flight.. Bell P-63A-1 airplane with enlarged horizontal tail and original contour production elevators at  $V_1 = 250-300$  MPH. Clean condition, normal rated power, two different altitudes, no bob weight. No flight tests have yet been made at the NACA with this airplane configurations.



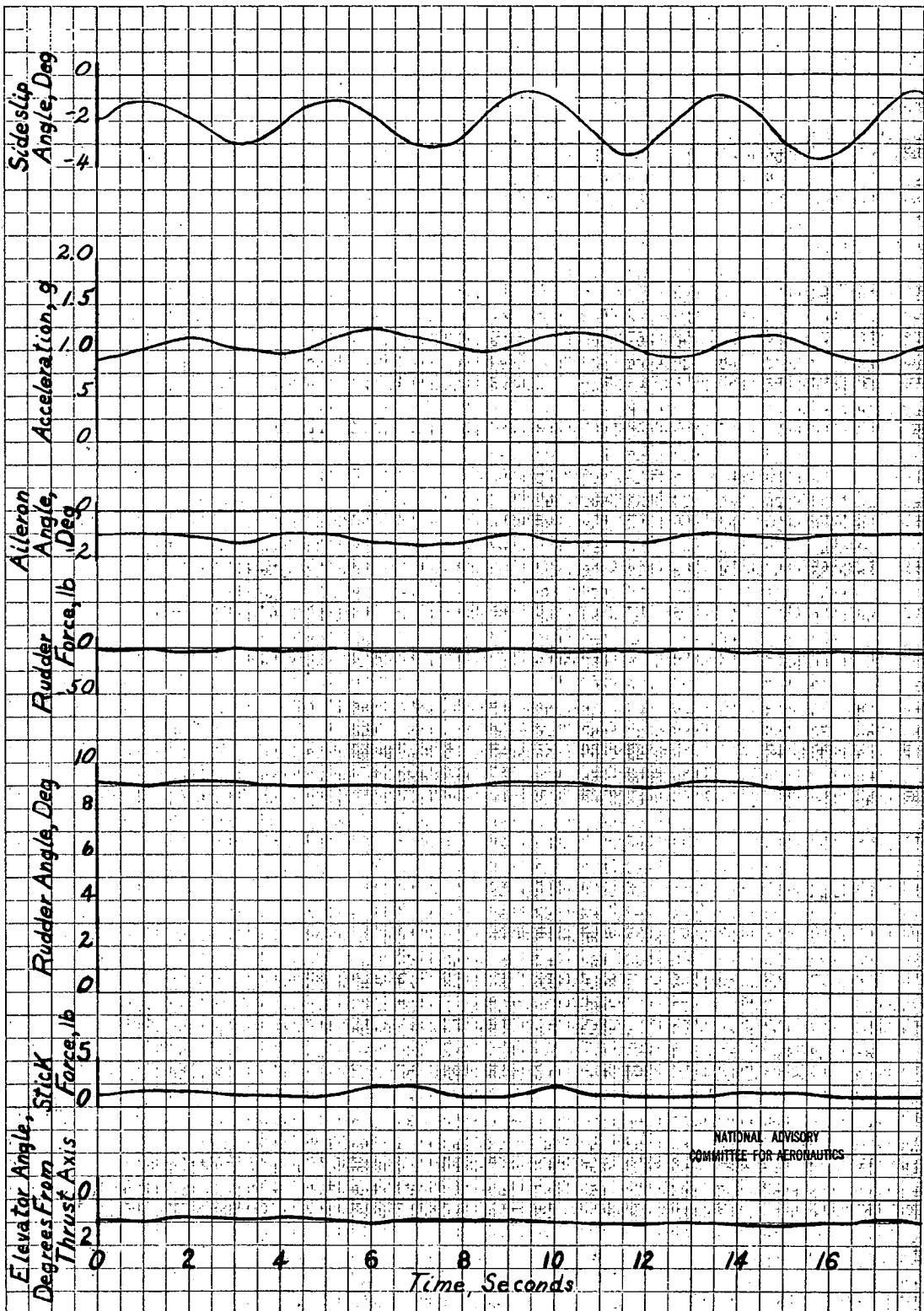

Figure 31.- Time history showing an undamped directional oscillation which occurred with a P-63A-1 airplane with the original vertical tail installed even though the pilot attempted to hold all controls fixed. Climbing condition at 22,000 feet altitude. The occurrence of such an oscillation indicates weak directional stability.

NATIONAL ADVISORY  
COMMITTEE FOR AERONAUTICS

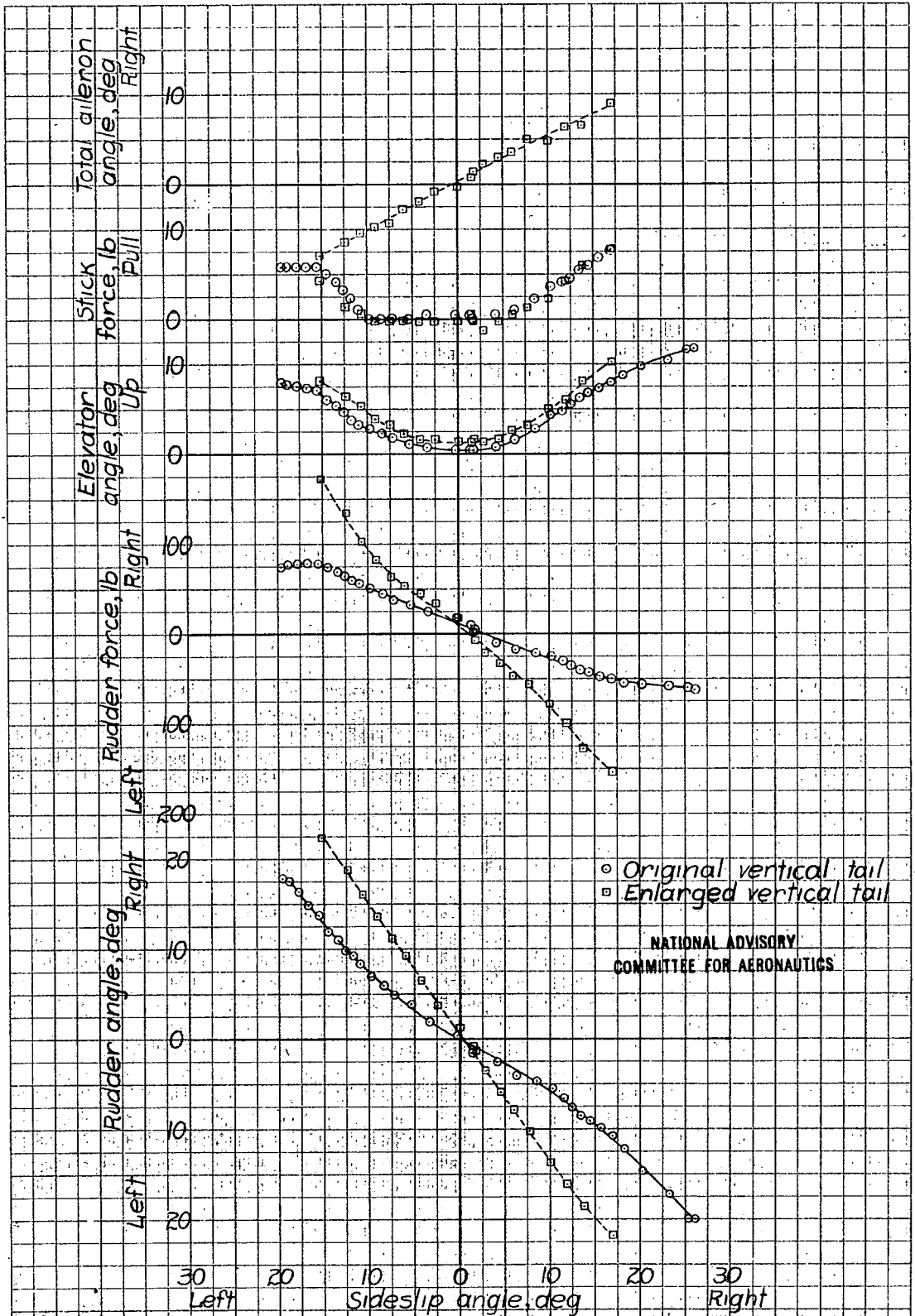

Figure 32.- Sideslip characteristics of P-63A-1 airplane with power off at  $V_{i_s} = 150$  mph at 5000 feet altitude.



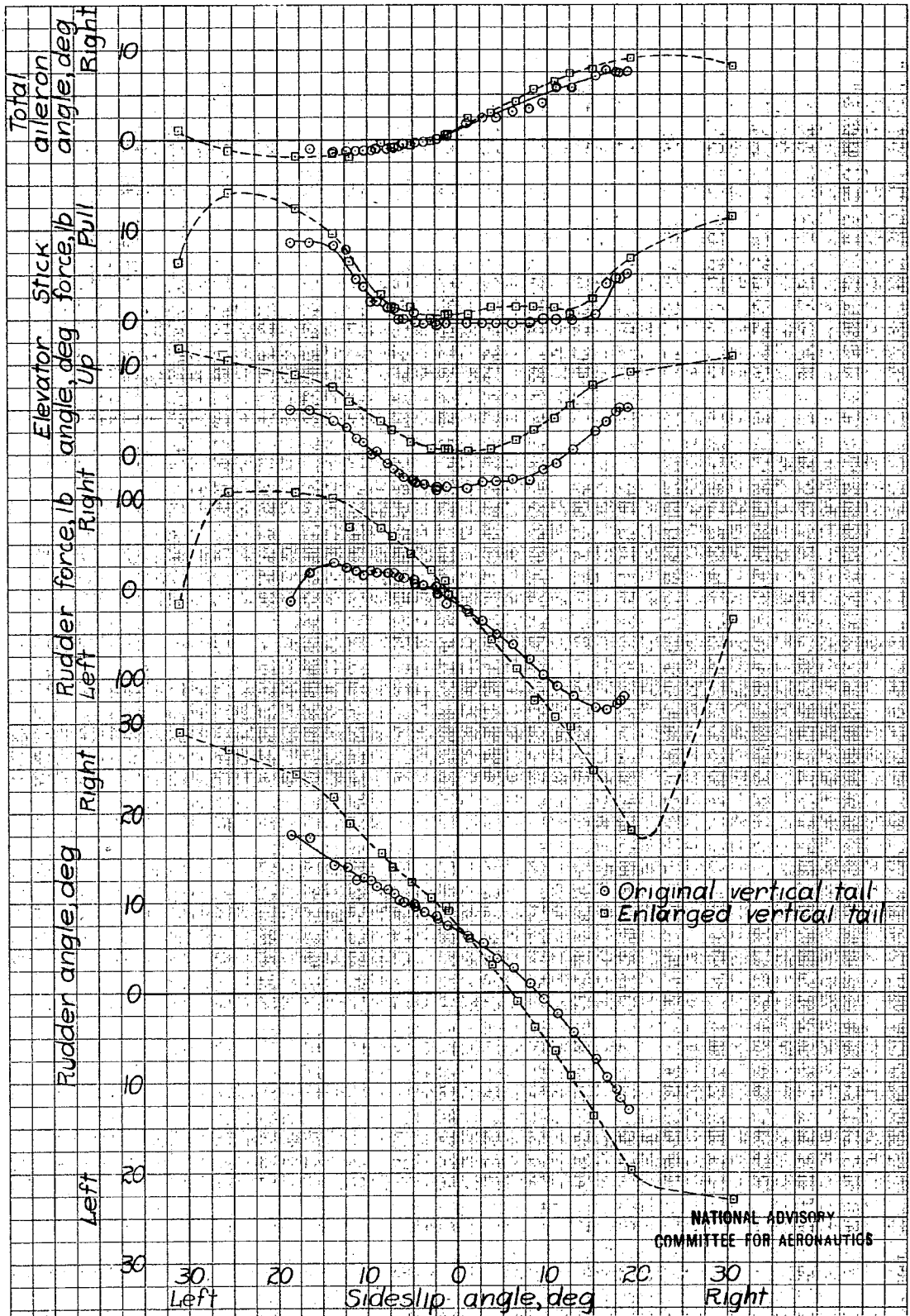

Figure 33.- Sideslip characteristics of P-63A-1 airplane with rated power (2600 RPM, 43 in. Hg.) at  $V_{1s} = 150$  mph at 5000 feet altitude.

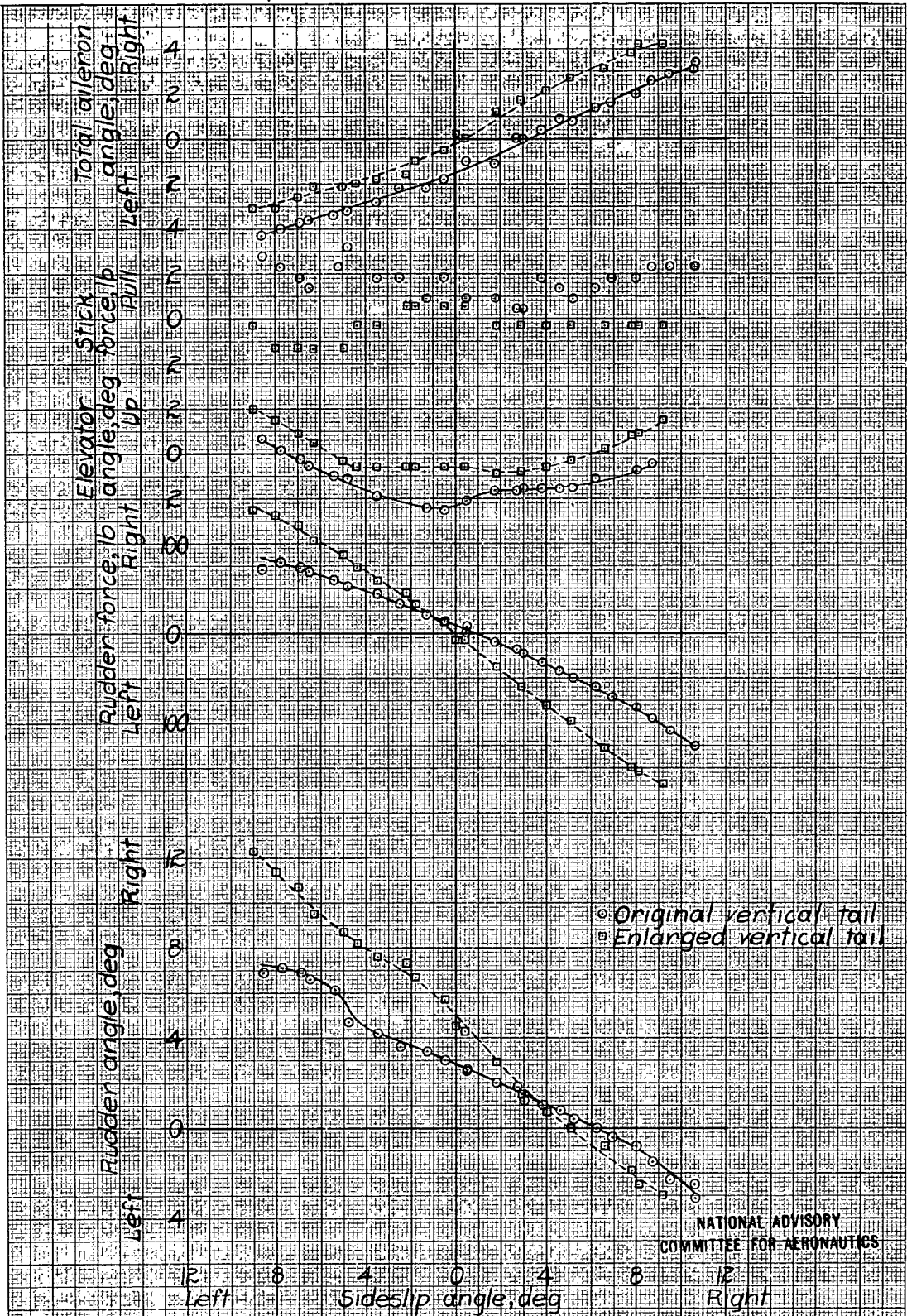

Figure 34.- Sideslip characteristics of P-63A-1 airplane with rated power (2600 RPM, 43 in Hg.) at  $V_{1g} = 250$  mph at 5000 feet altitude.

NATIONAL ADVISORY  
COMMITTEE FOR AERONAUTICS

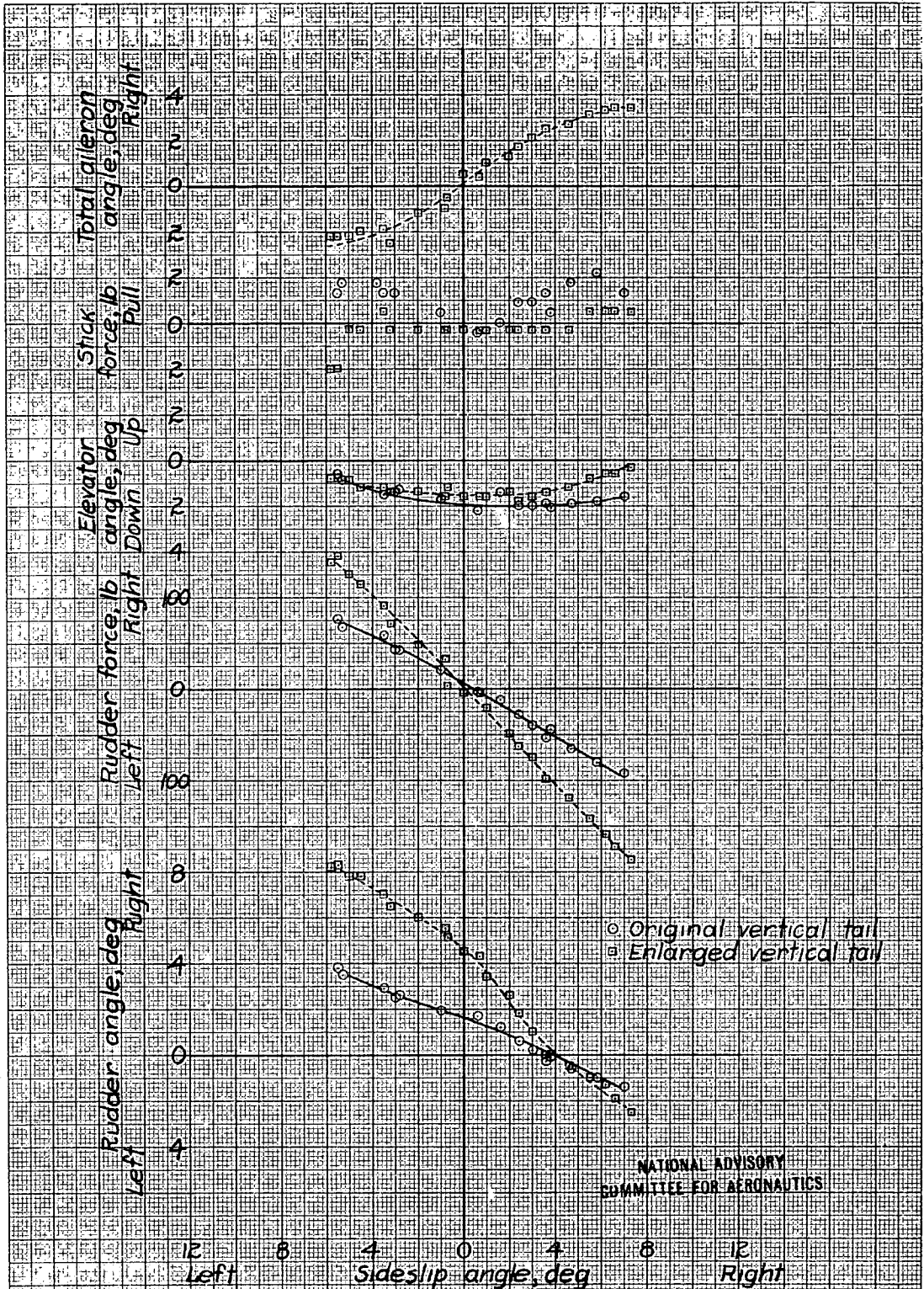

Figure 35.- Sideslip characteristics of P-63A-1 airplane with rated power (2600 RPM, 43 in. Hg.) at  $V_{1g} = 300$  mph at 5000 feet altitude.

NATIONAL ADVISORY  
COMMITTEE FOR AERONAUTICS

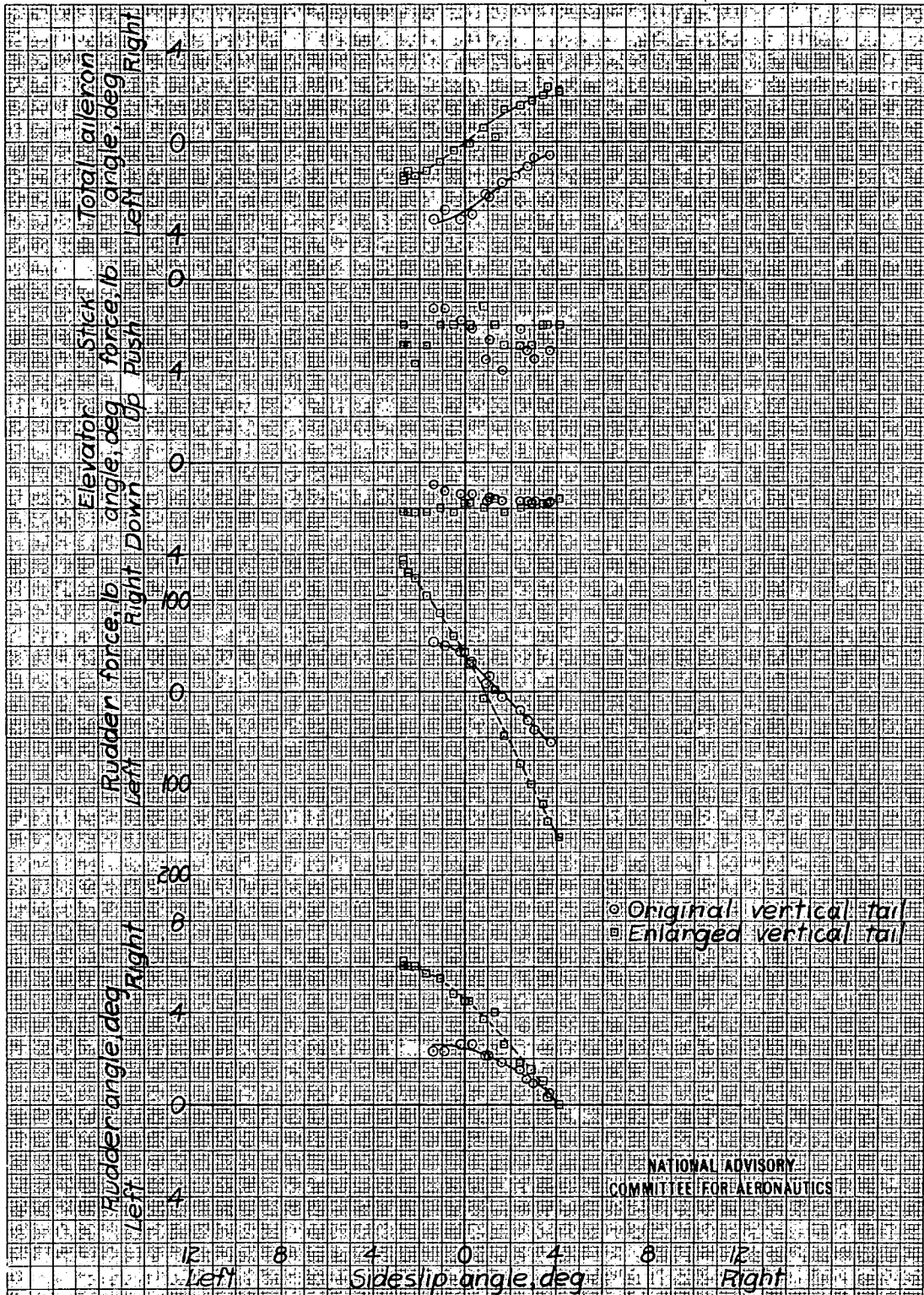

Figure 36.- Sideslip characteristics of P-63A-1 airplane with rated power (2600 RPM, 43 in. Hg.) at  $V_{is} = 400$  mph at 5000 feet altitude.



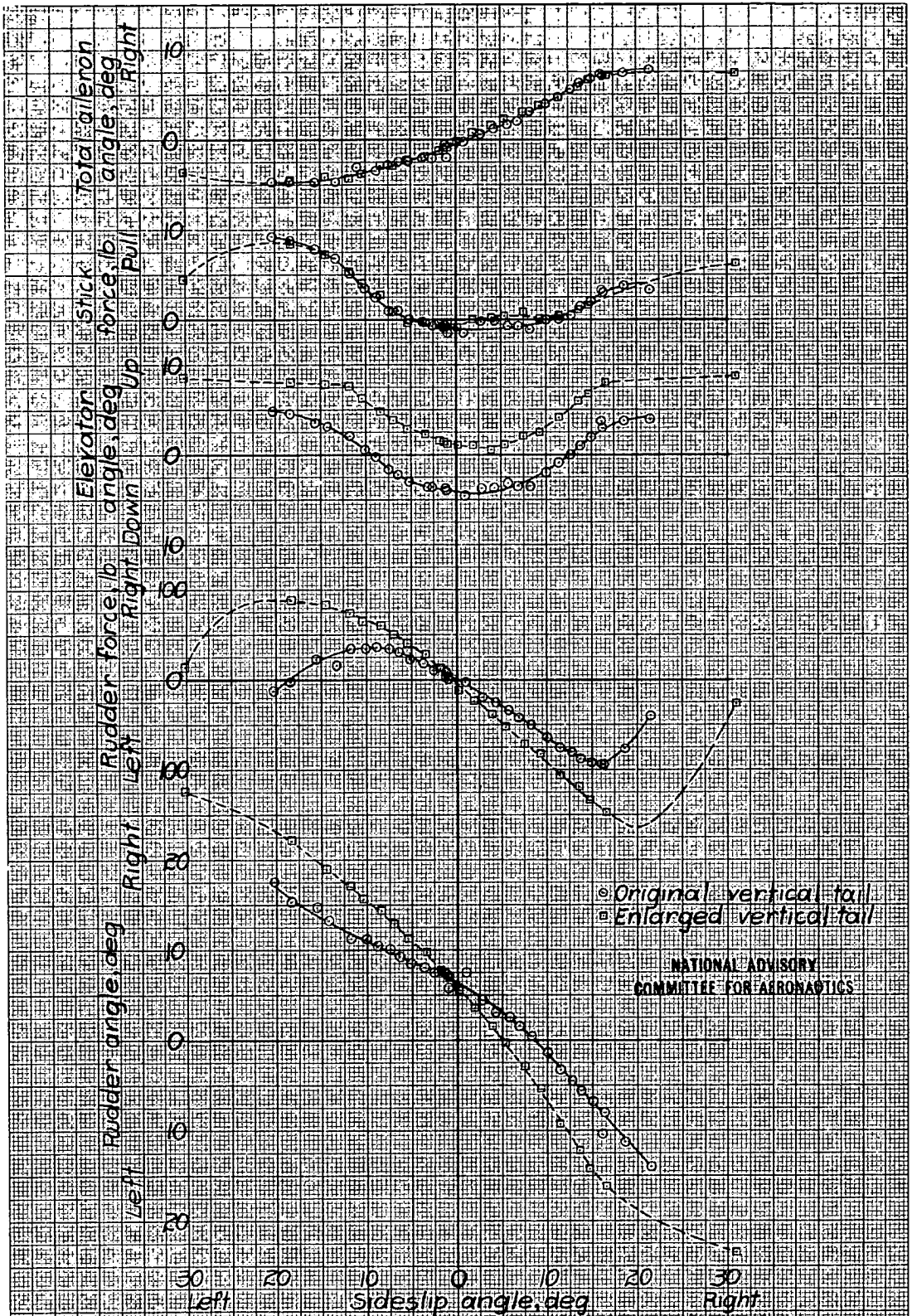

Figure 37.- Sideslip characteristics of P-63A-1 airplane with power on (2600 RPM, 38 in. Hg.) at  $V_{18}$  = 150 mph at 22,000 feet altitude.

NATIONAL ADVISORY  
COMMITTEE FOR AERONAUTICS

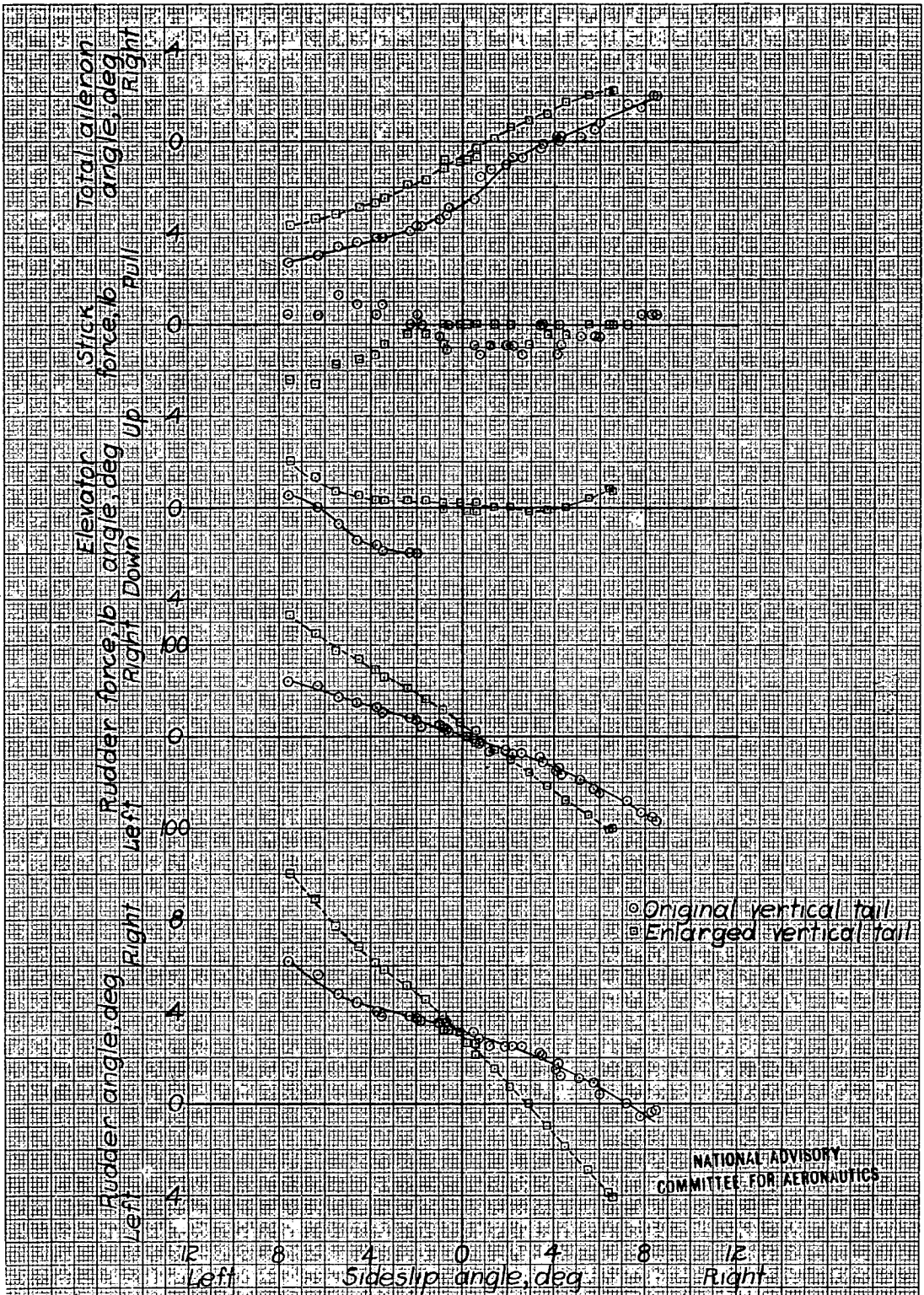

Figure 38.- Sideslip characteristics of P-63A-1 airplane with power on (2600 RPM, 39 in. Hg.) at  $V_{i_0} = 250$  mph at 25,000 feet altitude.



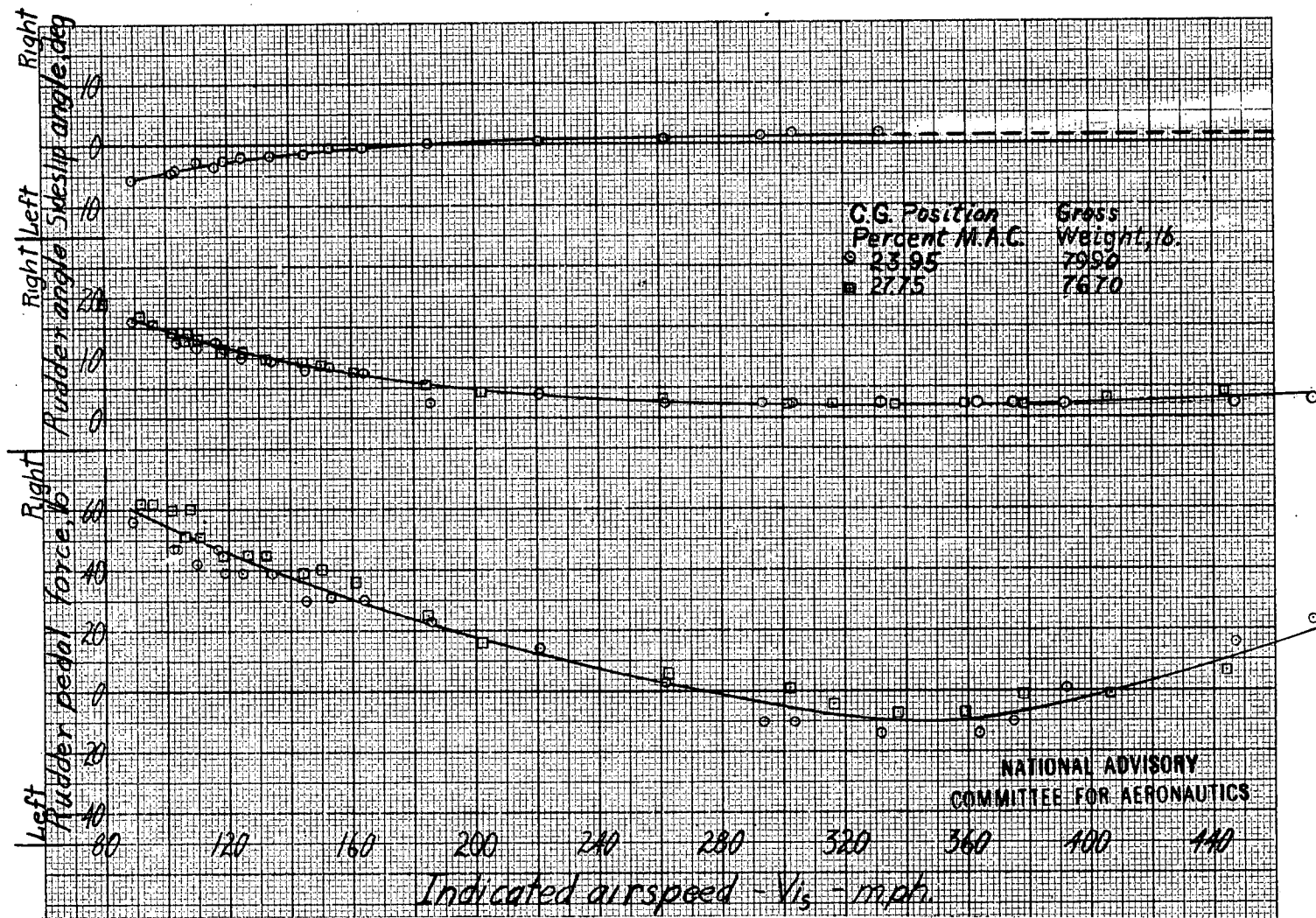

Figure 39.- Directional trim characteristics of P-63A-1 airplane with original vertical tail showing the variations in rudder force and angle with indicated airspeed to maintain straight, wings-level flight. Clean condition, normal rated power (2600 RPM, 43 in. Hg), altitude 5000 feet.

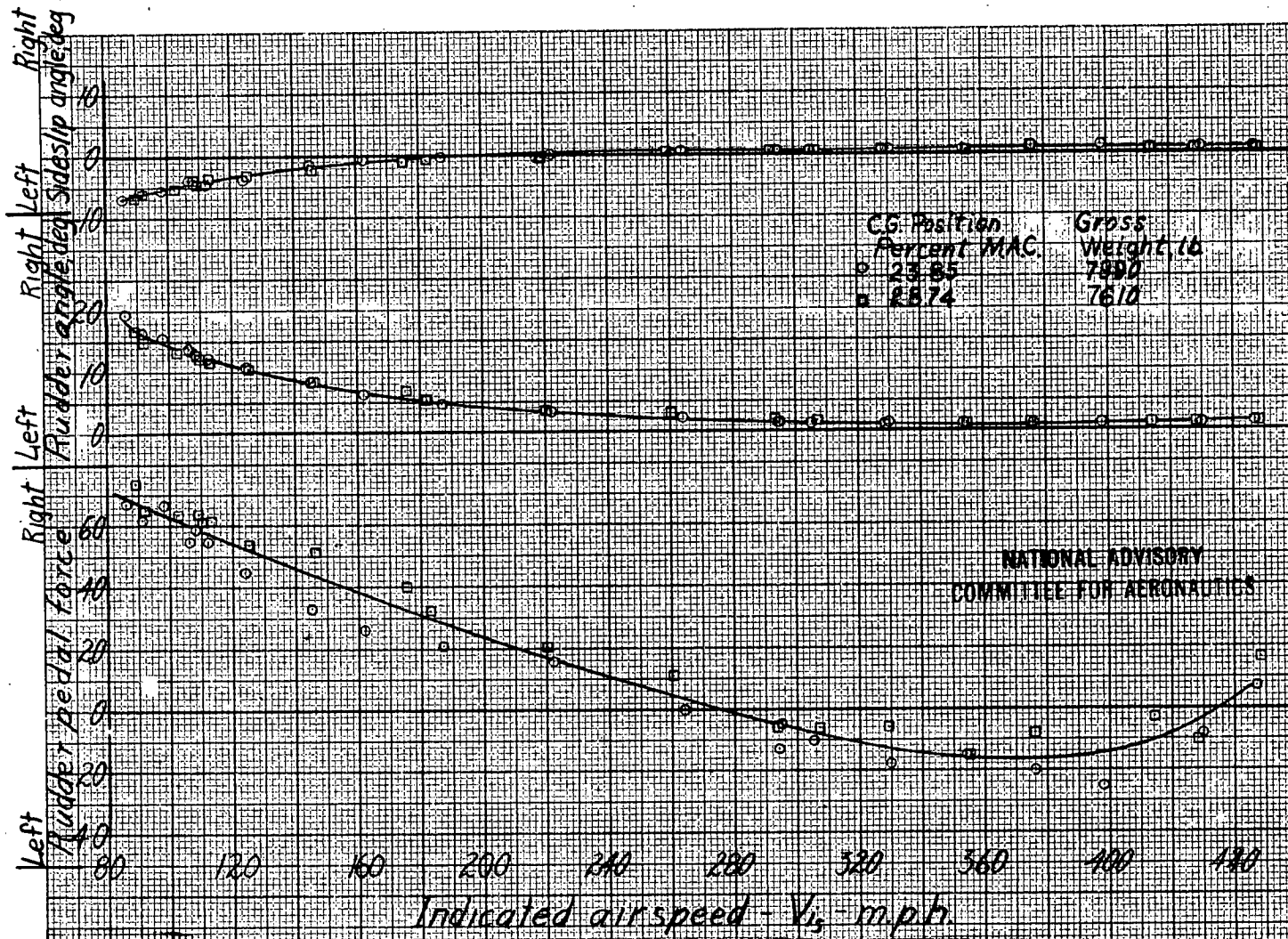

Figure 40.- Directional trim characteristics of P-63A-1 airplane with enlarged vertical tail surfaces showing the variation in rudder force and angle with indicated airspeed to maintain straight, wings-level flight. Clean condition, normal rated power (2600 RPM, 43 in. Hg.), altitude 5000 feet.

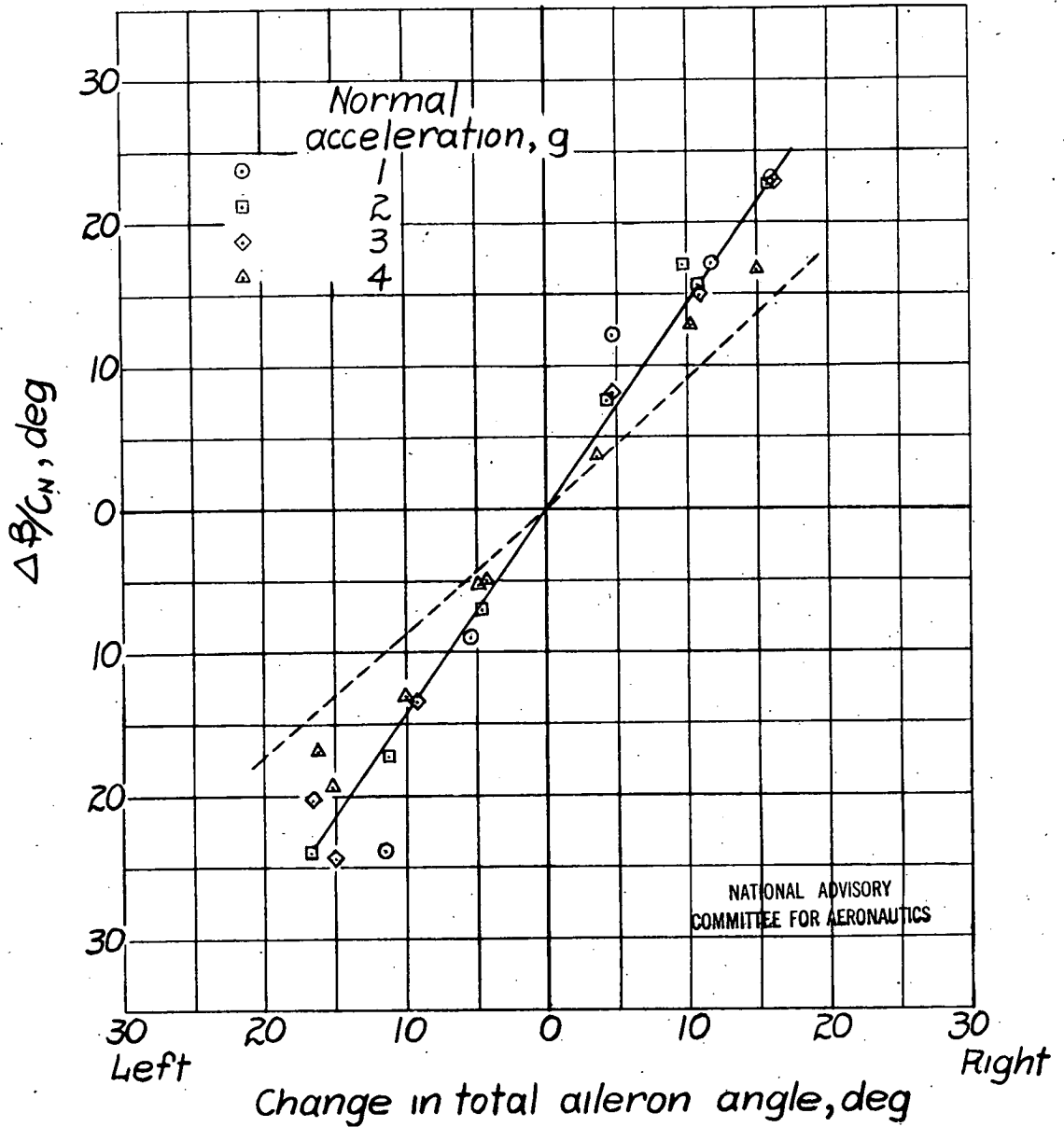
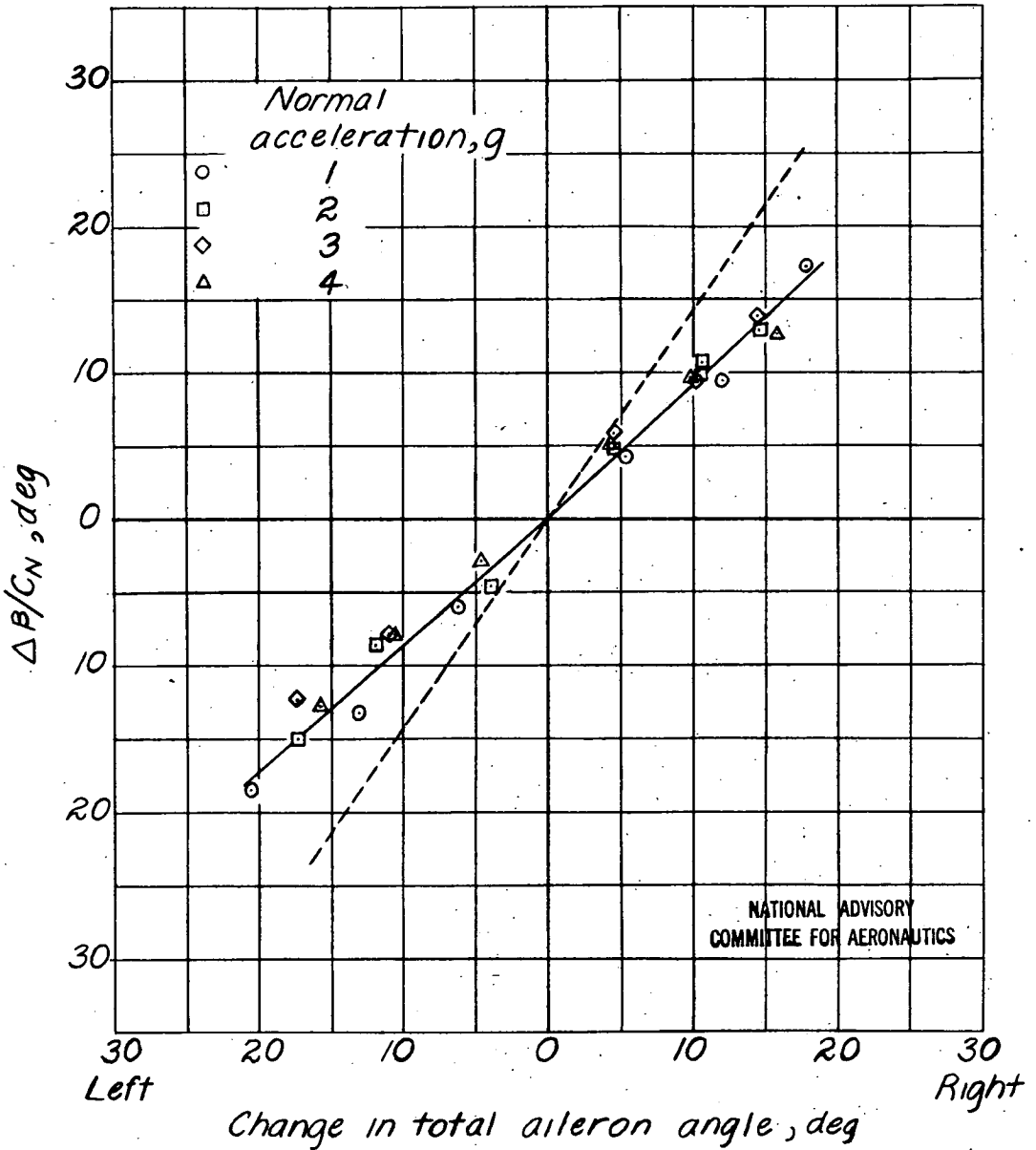

Figure 41.- Results of rudder-fixed rolls out of pull-outs at various normal accelerations at an indicated speed of 250 MPH at 5000 feet altitude using constant propeller blade angle and thrust coefficient. Bell P-63A-1 airplane (AAF No. 42-68889). (a) Original vertical tail. Dash line is faired curve for enlarged vertical tail shown in figure 41b.



(b) Enlarged vertical tail. Dash line is faired curve for original vertical tail shown in figure 41a.

Figure 41.- Concluded.

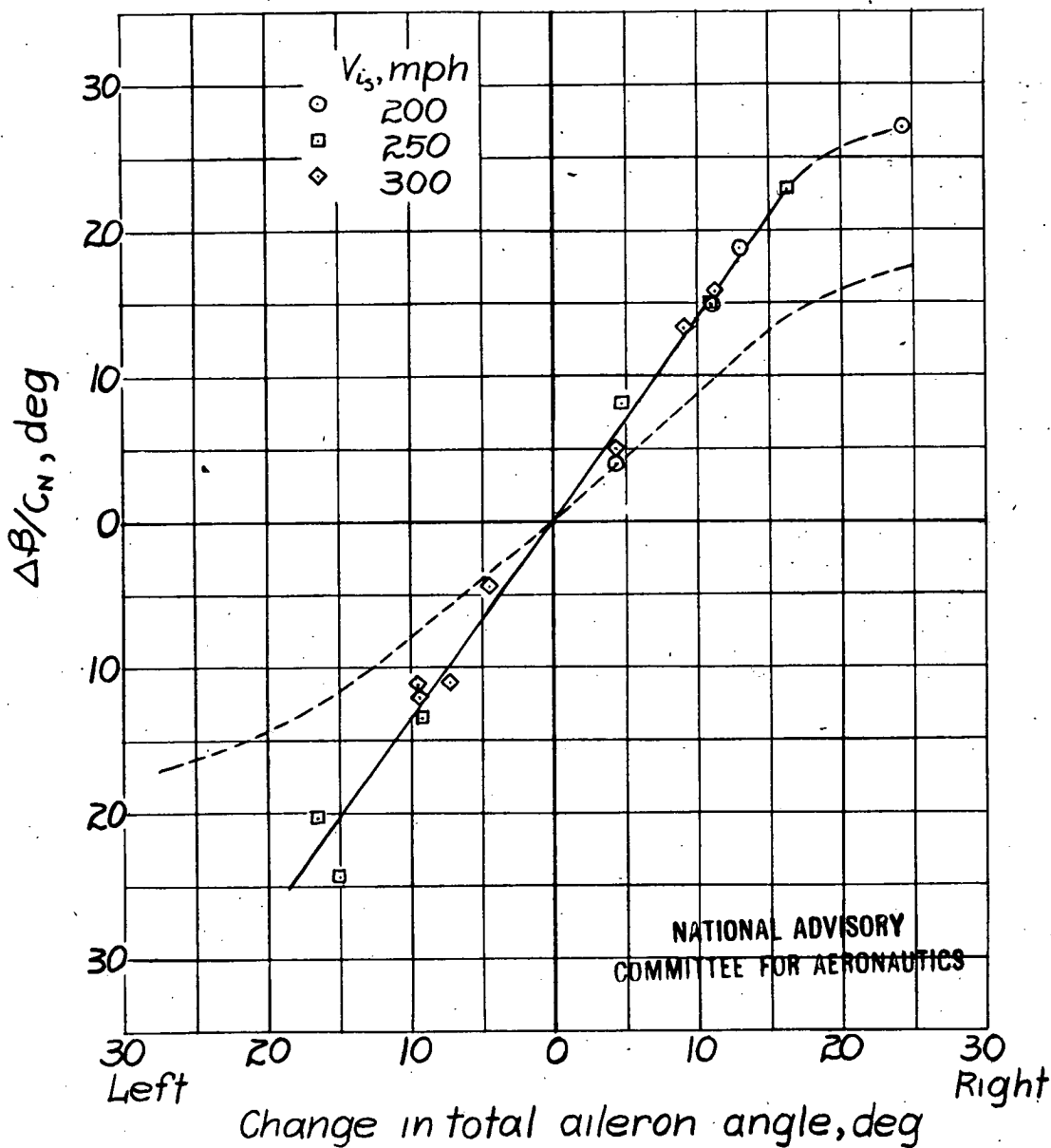
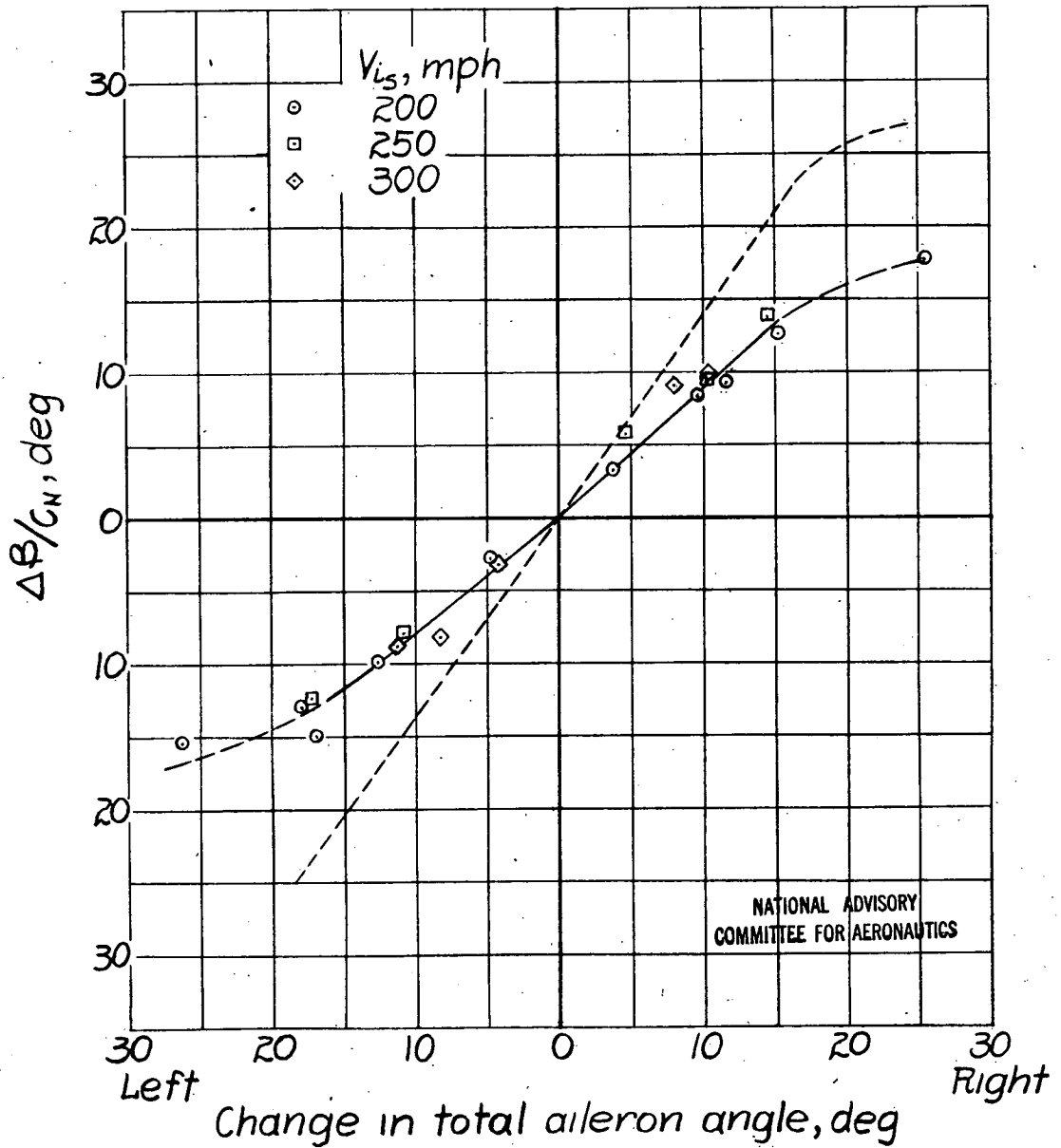

Figure 42.- Results of rudder-fixed rolls out of 3 g pull-outs at 5000 feet altitude at various speeds using constant propeller blade angle and thrust coefficient. Bell P-63A-1 airplane (AAF No. 42-68889). (a) Original vertical tail. Dash line is faired curve for enlarged vertical tail shown in figure 42b.



(b) Enlarged vertical tail. Dash line is faired curve for original vertical tail shown in figure 42a.

Figure 42.- Concluded.



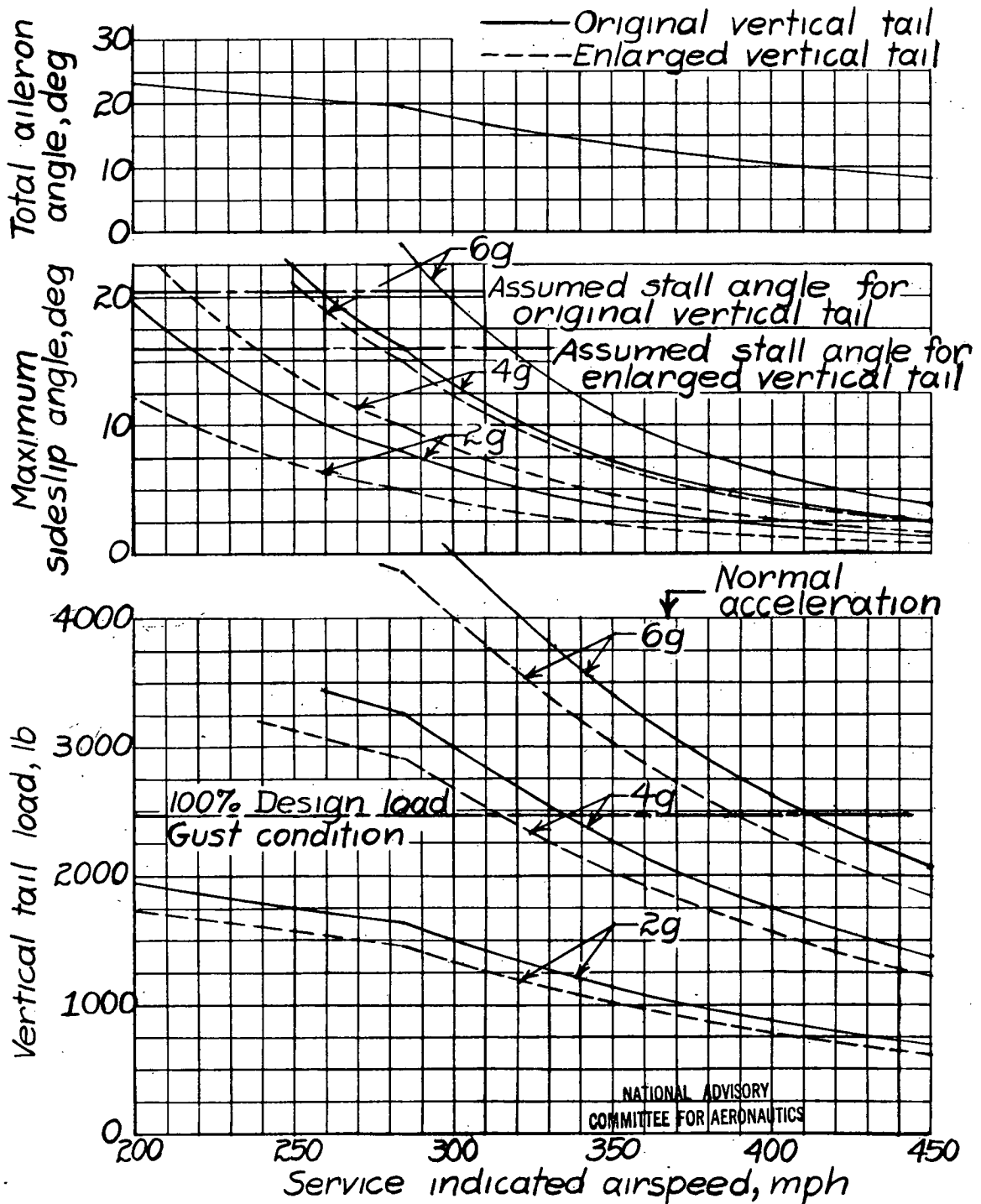

Figure 43.- Estimated maximum vertical tail loads to be expected in rudder-fixed rolls during accelerated flight employing 50 pounds aileron stick force.