

~~CONFIDENTIAL~~ RESTRICTED

NACA RM No. L8A09



26-APR 1948

UNCLASSIFIED

**NACA**

# RESEARCH MEMORANDUM

GENERAL HANDLING-QUALITIES RESULTS OBTAINED DURING  
ACCEPTANCE FLIGHT TESTS OF THE BELL XS-1 AIRPLANE

By

Walter C. Williams, Charles M. Forsyth, and Beverly P. Brown

Langley Memorial Aeronautical Laboratory  
Langley Field, Va.

CLASSIFICATION CANCELLED

~~CLASSIFICATION CHANGED~~

Authority: BACK R7 2857

Date: 12/11/53

~~CONFIDENTIAL~~

By: WCA 12/20/53

See

This document contains classified information affecting the National Defense of the United States within the meaning of the Espionage Act, USC 50:31 and 32. Its transmission or the revelation of its contents in any manner to an unauthorized person is prohibited by law. Information so classified may be imparted only to persons in the military and naval services of the United States, appropriate civilian officers and employees of the Federal Government who have a legitimate interest therein, and to United States citizens of known loyalty and discretion who of necessity must be informed thereof.

~~BACK R7 1724 E-1010-0-1~~

of J.W. Crowley Date 12/11/53

12/2/53

## NATIONAL ADVISORY COMMITTEE FOR AERONAUTICS

WASHINGTON  
April 19, 1948

NACA LIBRARY

RESTRICTED

LANGLEY MEMORIAL AERONAUTICAL  
LABORATORY  
Langley Field, Va.

UNCLASSIFIED  
~~CONFIDENTIAL~~

NACA RM No. L8A09

~~RESTRICTED~~

NATIONAL ADVISORY COMMITTEE FOR AERONAUTICS

RESEARCH MEMORANDUM

GENERAL HANDLING-QUALITIES RESULTS OBTAINED DURING ACCEPTANCE

FLIGHT TESTS OF THE BELL XS-1 AIRPLANE

By Walter C. Williams, Charles M. Forsyth, and Beverly P. Brown

SUMMARY

During the acceptance tests conducted by the Bell Aircraft Corporation on the Bell XS-1 transonic research airplane, NACA instruments were installed to measure the stability and control characteristics and the aerodynamic loads. Tests were made in gliding flight and in powered flight. Two Bell XS-1 airplanes were used during the program; one airplane had wing and tail thicknesses of 10 percent and 8 percent of the chord, respectively, and the other airplane had wing and tail thicknesses of 8 percent and 6 percent of the chord, respectively. The results for the stability and control measurements are presented in this paper.

In general, the handling qualities of the Bell XS-1 airplane are satisfactory in the flight range from minimum speed to a Mach number of about 0.8, and the airplane should be satisfactory for use as a research vehicle. The longitudinal stability was positive but low for all conditions tested. The directional stability was exceptionally high, and the lateral stability was positive throughout the speed range tested. Aileron control was adequate. The stalling characteristics were considered satisfactory with stall warning in the form of buffeting. The large amount of friction in the control system, coupled with low control-operating forces, made exact control of the airplane difficult.

There was no appreciable difference in the handling qualities of the Bell XS-1 with the 10-percent-thick wing and with the 8-percent-thick wing in the speed range tested.

INTRODUCTION

During 1944, the Army and the NACA began a cooperative program for the development and the procurement of a series of airplanes for flight research in the transonic and supersonic speed range. This program was undertaken in anticipation of the increase in importance

UNCLASSIFIED

~~RESTRICTED~~

~~CONFIDENTIAL~~

of flight research in the transonic speed range where the aerodynamic characteristics of airplanes were known to show large and sudden changes and where wind tunnels would require long and painstaking development to provide dependable data.

As the first phase of this long-range high-speed flight research program, the Army Air Forces procured from the Bell Aircraft Corporation the XS-1, a straight-wing rocket-powered airplane. During the design of this airplane, extensive tests were run in NACA wind tunnels. When the airplane reached the flight-test stage, NACA recording instruments, which provided data on flights made during the Bell acceptance tests, were installed.

The first flight tests for the Bell XS-1 were a series of ten glide flights made at Pinecastle Army Air Field, Fla., in early 1946. During these flights, which were made for the purpose of flight-checking the technique of launching the Bell XS-1 from a B-29 and in order to obtain preliminary handling characteristics, the rocket motor-fuel tanks and accessories were not installed. NACA instrumentation for the measurement of stability and control characteristics was installed. The remaining demonstration flights were made at Muroc Army Air Base, Calif., from October 1946 to June 1947. During these flights, the rocket engine was installed. For these acceptance flights, the Bell Aircraft Corporation had to demonstrate that the airplane had satisfactory stability and control characteristics up to a Mach number of 0.8 and also had to demonstrate flight loads of 8g at an indicated airspeed not exceeding 500 miles per hour, and flight loads of 8g at the minimum speed at which this loading could be attained. Six glide flights and twenty powered flights were made during these tests. NACA instruments to measure stability and control characteristics and aerodynamic loads were installed for all flights. Two Bell XS-1 airplanes were used in these tests; one had a wing and tail thickness of 10 percent and 8 percent of the chord, respectively, and the other had a wing and tail thickness of 8 percent and 6 percent of the chord, respectively. Most of the flights were made with the airplane with the thicker surfaces, but some data were obtained for the airplane with the thinner surfaces.

The present paper summarizes the results of the stability and control tests made during the Bell conducted acceptance tests on the Bell XS-1. The results of the aerodynamic-loads measurements are presented in reference 1.

#### SYMBOLS

$V_i$	indicated airspeed, miles per hour
$V$	true airspeed, feet per second

M	Mach number
g	acceleration of gravity, feet per second per second
p	rolling velocity, radians per second
b	wing span, feet
$C_{n\psi}$	partial derivative of yawing-moment coefficient with respect to angle of yaw
$\mu$	airplane density factor $\left(\frac{m}{\rho S b}\right)$
m	mass of airplane, slugs
$\rho$	mass density of air, slugs per cubic foot
S	wing area, square feet
$C_N$	normal-force coefficient $\left(\frac{Wg}{0.7M^2 \rho S}\right)$
W	airplane weight, pounds
$p_s$	static pressure, pounds per square foot
$\tau$	elevator effectiveness $\left(\frac{dC_h}{d\delta} / \frac{dC_h}{d\alpha}\right)$

#### AIRPLANE

The Bell XS-1 airplane is a single-place, midwing monoplane powered by a four-cylinder, liquid-fuel rocket engine, built specifically for flight research in the transonic speed range. The physical characteristics of the airplane as tested are listed in table I. A three-view drawing of the airplane is presented in figure 1 and photographs of the airplane are presented as figure 2. The variation of control-surface position with wheel and pedal movement is presented in figure 3. Figure 4 presents no-load measurements of the control-system friction made by measuring the control position and control force as the control was slowly deflected. The large amounts of friction in the rudder and aileron control systems should be especially noted.

## INSTRUMENTATION

The NACA instrumentation installed in the Bell XS-1 airplane to measure the necessary quantities pertinent in determining the handling characteristics of the airplane consisted of standard NACA internal recording instruments synchronized by means of a timer, a 16-millimeter gun camera to photograph the pilot's instrument panel, a six-channel NACA radio telemeter, and an SCR 584 radar unit.

The standard NACA internal recording instruments measured the following quantities:

Indicated airspeed

Pressure altitude

Acceleration about three axes (normal, longitudinal, and transverse)

Rolling or pitching velocity

Sideslip angle

Control positions (elevator, stabilizer, rudder, and right aileron)

Control operating forces (elevator, aileron, and rudder)

The NACA radio telemeter recorded the following:

Indicated airspeed

Pressure altitude

Normal acceleration

Elevator position

Right aileron position

Rudder position

The SCR 584 radar set was modified for longer range and incorporated an M-2 optical tracking unit to reduce the hunt inherent with the radar when tracking is done automatically. The radar recorded airplane azimuth and elevation angle and slant range from which the Bell XS-1 flight path was obtained.

The use of both internal and remote recording of the quantities necessary to determine control behavior enhanced the possibilities of obtaining data for each flight, even in the case of an accident resulting in the loss of the airplane.

The elevator deflections presented in this paper were measured with respect to the stabilizer. The stabilizer angles were measured with respect to the fuselage center line and are considered positive when the stabilizer nose is up. Rudder and aileron deflections were measured with respect to their neutral positions.

A preliminary calibration of the error in the static-pressure system was made by the radar-tracking method. The results of this calibration, although limited, indicated that the static-pressure error was small and so, consequently, was neglected.

### TESTS, RESULTS, AND DISCUSSION

Since only a limited number of flights were made during the acceptance tests, a complete evaluation of the handling characteristics of the airplane was not obtained. It is felt, however, that sufficient information has been obtained to determine whether the airplane possesses satisfactory handling qualities for the speed range tested under normal operating conditions and to serve as a guide for future research flying at higher speeds.

The Bell XS-1 airplane is carried aloft in the modified bomb bay of a B-29 airplane and launched at altitude. The launching characteristics of the Bell XS-1 are entirely satisfactory when the XS-1 is dropped from the B-29 at about  $-0.3g$  normal acceleration. The XS-1 is launched from the B-29 at an indicated airspeed of 260 miles per hour so that launching is accomplished well above the stalling speed of the XS-1, which is over 200 miles per hour when the XS-1 is fully serviced.

Control-force and position measurements obtained while various combinations of the four rocket chambers are either ignited or cut off indicate that trim changes due to power are small. In view of the large changes in wing loading with the rocket engine operating and difficulties experienced in determining airplane weight in flight, most of the results presented herein are for the fuel-empty condition. The wing loadings and center-of-gravity locations for power-on flight are therefore only approximations.

#### Longitudinal Stability and Control

The dynamic longitudinal stability of the Bell XS-1 was investigated in maneuvers made by abruptly deflecting and releasing the

elevator control. Results of these tests are presented in figure 5. This figure shows that the short-period longitudinal oscillation is completely damped.

The static longitudinal stability was obtained from measurements of the elevator positions and forces required to trim at various speeds. Figures 6 to 9 present the results of these measurements. In figure 6 the elevator position and force required for trim as a function of indicated airspeed is plotted for steady gliding flight at various wing loadings and stabilizer positions for the airplane with the 10-percent-thick wing. Examination of the data shows that both the stick-fixed and stick-free static longitudinal stability are positive but low. The relatively high friction in the elevator control ( $\pm 3$  lb) combined with the small size of the elevator and low stick-free stability has the effect of masking the measured control forces. The elevator-position variation with indicated airspeed of figure 6 is replotted in figure 7 as the variation of elevator position for trim with normal-force coefficient. The elevator positions have been corrected to zero stabilizer angle by using a value of  $r$ , the elevator effectiveness, of 0.42 obtained from flight data. A marked increase in the stick-fixed static stability is noticed as maximum lift is approached. These results are in general agreement with wind-tunnel results.

The variation of elevator position with indicated airspeed and Mach number for steady power-on flight is presented in figure 8. The center-of-gravity location for these results was at about 22.6 percent mean aerodynamic chord as compared with the center-of-gravity location of about 25 percent mean aerodynamic chord for the results of figures 6 and 7. The speed range covered was from an indicated airspeed of 284 miles per hour to 406 miles per hour and for a Mach number range from 0.53 to 0.75. The results as seen from this figure indicate that power has little effect on the longitudinal stability of the Bell XS-1 up to the highest speeds tested. Also, no undesirable longitudinal-trim changes are indicated.

The results of tests with the 8-percent-thick wing (fig. 9) in steady gliding flight, although limited, bear out the positive but low static longitudinal stability evidenced by the results for the airplane incorporating the 10-percent-thick wing. No appreciable differences in the static longitudinal stability of the Bell XS-1 airplane with either the 10-percent-thick or the 8-percent-thick wing are evidenced from these results (figs. 6 and 9).

The elevator force and deflection required to produce a unit change in normal acceleration and the elevator deflection required to produce a unit change in normal-force coefficient in turns are used to determine the longitudinal stability of the Bell XS-1 airplane in accelerated flight. These data were obtained in turns with steadily increasing normal acceleration at an essentially constant airspeed and

altitude so that complete data for a given Mach number would be obtained in one run. Time histories of two turns are presented in figures 10 and 11. In one turn (fig. 10) the record switch was turned on after the turn was started, but the turn was fairly steady considering the friction in the control system. In the other turn (fig. 11) the elevator was moved in an unsteady manner and the rate of increase of acceleration with time was too high at the beginning of the turn. Since several of the turns were made in this manner, the slopes of the curves of elevator deflection against normal-force coefficient and the elevator force per g should be compared only in a general way for large changes in acceleration or lift coefficient for turns at different Mach numbers. Figures 12 through 16 present the stick-fixed and stick-free accelerated-flight longitudinal-stability results obtained from the turns. The Mach number range covered is from 0.48 to 0.75. The elevator-position variation with normal acceleration and normal-force coefficient and the force per g gradients indicate a decrease in stability for turns (figs. 13 to 16) made at Mach numbers from 0.65 to 0.72. At the highest Mach number tested ( $M = 0.75$ ) an increase in longitudinal stability is indicated (figs. 14 and 16).

The elevator control in landing was sufficiently powerful to effect landings near minimum speed with the stabilizer set near neutral in the center-of-gravity range tested. Time histories of landings are given in figures 17, 18, and 19. It should be noted that in figure 19 where the highest lift coefficient was reached, nearly full-up elevator was used.

#### Lateral and Directional Stability and Control

The only measure of aileron effectiveness obtained during the Bell conducted acceptance flights was obtained from a few rudder-fixed aileron rolls at indicated airspeeds of 153 miles per hour, 260 miles per hour, and 315 miles per hour. The results are plotted in figure 20 as the variation of helix angle  $pb/2V$  with right aileron deflection. Examination of this figure shows that although the maximum value of  $pb/2V$  with full aileron deflection as obtained in the rolls at an indicated airspeed of 260 miles per hour is below the minimum acceptable of 0.07 radian, the rate of change of  $pb/2V$  with aileron deflection compares fairly well with that of present-day fighters. The aileron control is considered satisfactory, however, because even though the maximum  $pb/2V$  obtainable with the Bell XS-1 is low, the rolling velocities are fairly high because of the short wing span. No satisfactory measurements of the aileron control forces were obtained because the high aileron friction (see fig. 4) masked the aileron forces. An indication of the effect of the aileron friction in the handling characteristics of the Bell XS-1 airplane is given in figure 21, which is a sample time history from a steady-flight record. The pilot is continually applying aileron force; the ailerons, however, are not moving.



The static directional stability of the Bell XS-1 was measured in continuous sideslips made by slowly deflecting the rudder and by using aileron and elevator control to maintain straight flight at constant speed. The results of these tests are presented in figures 22 to 24 where rudder, aileron, and elevator position and angle of bank are shown as functions of sideslip angle. No control-force measurements were made during these tests. The directional stability as indicated by the variation of rudder position with sideslip angle is very high. Values of  $C_{n\dot{\psi}}$  calculated from these data show very close agreement with the wind-tunnel measured value of  $C_{n\dot{\psi}} = 0.0034$ . This value of  $C_{n\dot{\psi}}$  indicates directional stability about three times as great as that measured on fighters which were considered to have good directional stability. The lateral stability (dihedral effect) is positive for all conditions tested as indicated by the variation of aileron position with sideslip angle. The pitching moment due to sideslip was small under all conditions tested as shown by the variation of elevator angle with sideslip angle. The cross-wind force was positive; that is, right bank accompanied right sideslip.

The sideslip due to the use of ailerons was small even at low speeds due to the high directional stability and relatively low values of helix angle  $\psi_b/2V$ . Time histories of aileron rolls made with rudder fixed are shown in figure 25. The rudder control was sufficiently powerful to overcome the sideslip due to the use of ailerons as indicated in figure 26, which presents time histories of abrupt aileron rolls in which the pilot overcontrolled and used more rudder than necessary to overcome the sideslip due to ailerons.

During the course of the acceptance flight tests, inadvertent lateral oscillations were encountered at fairly high Mach numbers which were induced by small control movements. These oscillations were poorly damped. A time history of an oscillation encountered in straight flight is presented in figure 27. An oscillation which occurred during a turn entry is shown in figure 28. A lateral oscillation following abrupt release of the rudder from a yawed condition is shown in figure 29. It should be noted that the oscillation continues at small amplitude although the initial damping of the disturbance is satisfactory.

Previous analysis of the lateral-stability boundaries for the Bell XS-1 indicated that, with the high directional stability, the airplane was in the region of spiral divergence and well removed from the boundary of unstable lateral oscillations. These poorly damped oscillations were, therefore, difficult to explain. It was thought that possibly fuel sloshing might be responsible for the poor damping of these oscillations since large quantities of fuel are carried in spherical tanks. In order to investigate the possibility of the fuel affecting the damping of the lateral oscillation, a series of

pilot-induced oscillations were made with various amounts of fuel aboard. The altitude for the maneuvers was varied so that the airplane density factor and Mach number were essentially constant. The pilot attempted to deflect the rudder abruptly and then to return the rudder to neutral and hold it there. The results of these tests are presented as time histories of the rudder kicks in figure 30. As can be seen in this figure, the pilot did not hold the rudder or ailerons steady after initially deflecting the rudder. It is difficult to draw any definite conclusions concerning the effects of fuel on the damping of the lateral oscillations because of these control motions. There is no evidence, however, that the presence of fuel aboard had any effect on the damping of the lateral oscillations.

### Stalling Characteristics

The stalling characteristics of the Bell XS-1 were investigated in unaccelerated flight and in accelerated flight. Time histories of stalls made with flaps and gear up are presented in figures 31 and 32 for the Bell XS-1 with the 10-percent-thick wing. In the stall presented in figure 31, the pilot discontinued the stall approach at the first roll-off. The pilot reported that the roll-off was preceded by buffeting. In the stall presented in figure 32, the pilot continued the stall approach after the initial roll. An oscillation in roll developed which the pilot controlled up to the stall which was evidenced by the airplane pitching downward. It should be noted that full-up elevator was used at the stall. For this time history, it was assumed that the airplane was at 1g up to the time of minimum speed, in calculating values of normal-force coefficient. A time history of a stall made with the Bell XS-1 with the 8-percent-thick wing, flaps and gear up, is presented in figure 33. The stalling characteristics with the 8-percent-thick wing are similar to the characteristics measured with the 10-percent-thick wing. Time histories of stalls made with flaps and gear down are presented in figures 34 and 35 for the 10-percent-thick and 8-percent-thick wings, respectively. The stalling characteristics with flaps and gear down are similar to the characteristics with flaps and gear up. The pilot reported stall warning in the form of buffeting in all cases, and the rolling motions during the stall were never violent. The stalling characteristics in 1g flight, as measured during the flight tests, are in general agreement with the stalling characteristics predicted from the wind-tunnel tests.

The stalling characteristics in accelerated flight were considered satisfactory. There was stall warning in the form of buffeting, and there were no violent motions of the airplane as the stall was approached. A time history of a stalled turn is presented in figure 36. Time histories of abrupt pull-ups to the stall are presented in figures 37 and 38. It should be noted in figure 37 that a rolling

oscillation accompanies the stall, but the airplane did not roll completely over when the ailerons were not used. In figure 38, aileron control was applied at the stall and a snap roll resulted.

### CONCLUSIONS

General handling-qualities results obtained during the acceptance tests conducted by the Bell Aircraft Corporation on the XS-1 airplane showed the following:

1. In general, the handling qualities of the Bell XS-1 airplane were satisfactory for all normal operating conditions tested, from minimum speed to about a Mach number of 0.8, and the airplane should be satisfactory for a research vehicle.
2. The large amounts of friction in the control system made precision flying of the airplane difficult, and also caused difficulties in the measurement of control forces.
3. No appreciable differences were noted between the handling characteristics of the Bell XS-1 with the 10-percent-thick wing and with the 8-percent-thick wing.
4. The static longitudinal stability was positive but low throughout the speed range tested. No abnormal trim changes due to Mach number effects were noted.
5. The longitudinal stability in accelerated flight was positive throughout the speed range. A region of low stability was noted in the Mach number range from 0.65 to 0.72, but the stability is increased at a Mach number of 0.75.
6. The elevator control was sufficiently powerful to effect landings near minimum speed with the stabilizer near neutral and the center of gravity at approximately 25 percent mean aerodynamic chord.
7. The maximum value of  $pb/2V$  obtainable with full aileron deflection was below the required minimum of 0.07 but, due to the short wing span, the rolling velocities were high enough that the control was considered satisfactory.
8. The directional stability as measured in steady sideslips was very high. The sideslip due to the use of ailerons was very low, and the rudder power was sufficient to overcome any sideslip due to roll.

9. The lateral stability, as measured in steady sideslips, was positive throughout the speed range tested.

10. Poorly damped lateral oscillations were encountered which cannot be accounted for by the relation of directional stability to lateral stability, nor can the poor damping of these oscillations be attributed to fuel sloshing.

11. The stalling characteristics were satisfactory in straight flight and accelerated flight.

Langley Memorial Aeronautical Laboratory  
National Advisory Committee for Aeronautics  
Langley Field, Va.

#### REFERENCE

1. Beeler, De E., and Mayer, John P.: Measurements of the Wing and Tail Loads during the Acceptance Tests of XS-1 Research Airplane. NACA RM No. L7L12, 1947.

TABLE I

## PHYSICAL CHARACTERISTICS OF BELL XS-1 AIRPLANE

Engine: . . . . .	Reaction Motors, Inc. Model 6000C4
Rating . . . . .	1500 lb static thrust at sea level for each of the four rocket cylinders
Propellant:	
Fuel . . . . .	Diluted ethyl alcohol
Oxidizer . . . . .	Liquid oxygen
Propellant flow . . . . .	Approximately 7.9 lb/sec/cylinder
Fuel feed . . . . .	High pressure nitrogen gas
Weight for acceptance tests:	
Maximum:	
With full load and incorporating 8-percent-thick wing, lb . . . . .	12,250
With full load and incorporating 10-percent-thick wing, lb . . . . .	12,000
Minimum:	
Landing condition, 8-percent-thick wing, lb . . . . .	7,000
Landing condition, 10-percent-thick wing, lb . . . . .	6,750
Without engine or accessories (Fla. tests), lb . . . . .	4,230
Wing loading:	
Maximum (8-percent-thick wing with full fuel load), lb/sq ft . . . . .	94.4
Minimum (10-percent-thick wing without engine or accessories, Fla. tests), lb/sq ft . . . . .	32.6
Center-of-gravity travel, percent M.A.C. . . . .	Maximum 22.1 percent full load to 25.3 percent empty
Over-all height, ft . . . . .	10.85
Over-all length, ft . . . . .	30.90
Wing:	
Area (including section through fuselage) sq ft . . . . .	130
Span, ft . . . . .	28
Airfoil section . . . . .	NACA 65,-110(a = 1) and NACA 65,-108(a = 1)
Mean aerodynamic chord, in.: . . . . .	57.71
Location (aft of L.E. root chord), in. . . . .	6.58
Aspect ratio . . . . .	6
Root chord, in. . . . .	74.2

TABLE I - Continued

## PHYSICAL CHARACTERISTICS OF BELL XS-1 AIRPLANE - Continued

Tip chord, in. . . . .	37.1
Taper ratio . . . . .	2:1
Incidence, deg:	
Root . . . . .	2.5
Tip . . . . .	1.5
Sweepback (leading edge), deg . . . . .	5.05
Dihedral (chord plane), deg . . . . .	0
Wing flaps (plain):	
Area, sq ft . . . . .	11.6
Span, ft . . . . .	5.83
Chord, root, in. . . . .	14.84
Chord, tip, in. . . . .	10.58
Travel, deg . . . . .	60
Aileron:	
Area (each aileron behind hinge line), sq ft . . . . .	3.15
Span, ft . . . . .	5.8
Travel, deg . . . . .	±12
Chord, percent wing chord . . . . .	15
Root-mean-square chord, ft . . . . .	0.565
Horizontal tail:	
Area, sq ft . . . . .	26.0
Span, ft . . . . .	11.4
Aspect ratio . . . . .	5
Distance from airplane design c.g. to 25 percent M.A.C. . . . .	
of tail, ft . . . . .	13.3
Stabilizer travel, deg (power actuated) . . . . .	5° nose up and 10° nose down
Elevator (no aerodynamic balance):	
Area, sq ft . . . . .	5.2
Travel from stabilizer, deg . . . . .	15° nose up and 7° nose down
Root-mean-square chord, ft . . . . .	0.464
Chord, percent horizontal-tail chord . . . . .	20



TABLE I - Concluded

## PHYSICAL CHARACTERISTICS OF BELL XS-1 AIRPLANE - Concluded

## Vertical tail:

Area (excluding dorsal fin), sq ft . . . . .	25.6
Total height above horizontal stabilizer, in. . . . .	61.25

## Fin:

Area (excluding dorsal), sq ft . . . . .	20.4
Offset from thrust axis, deg . . . . .	0

## Rudder (no aerodynamic balance):

Area, sq ft . . . . .	5.2
Span, ft . . . . .	6.58
Travel, deg . . . . .	$\pm 15$
Root-mean-square chord, ft . . . . .	0.798
Chord, percent vertical-tail chord . . . . .	20



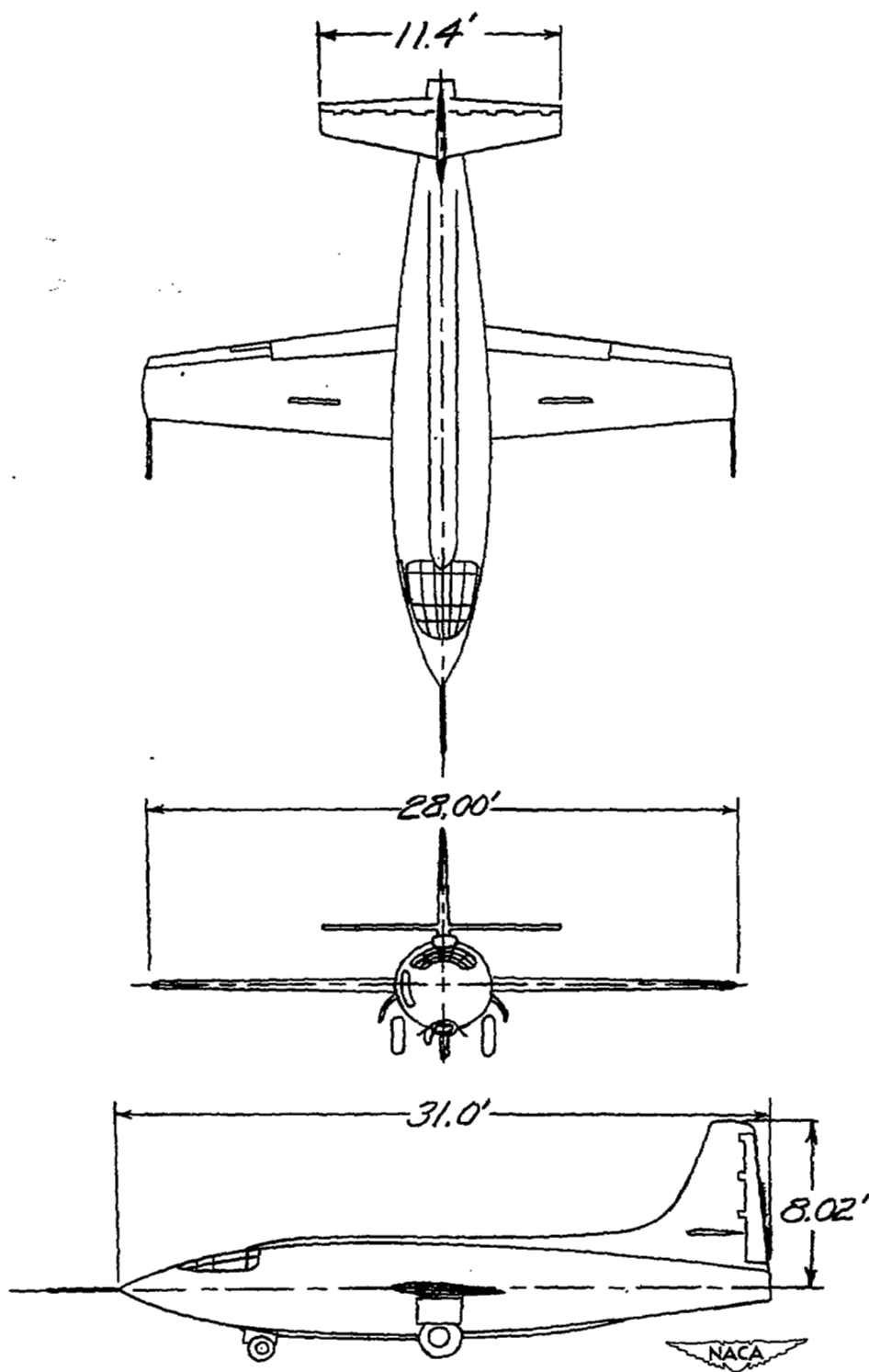
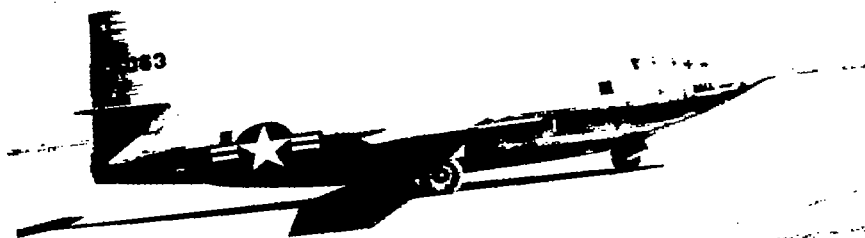

Figure 1.- Three-view drawing. X-1 airplane.







(a) Side view.



(b) Front view.

Figure 2.- XS-1 airplane.



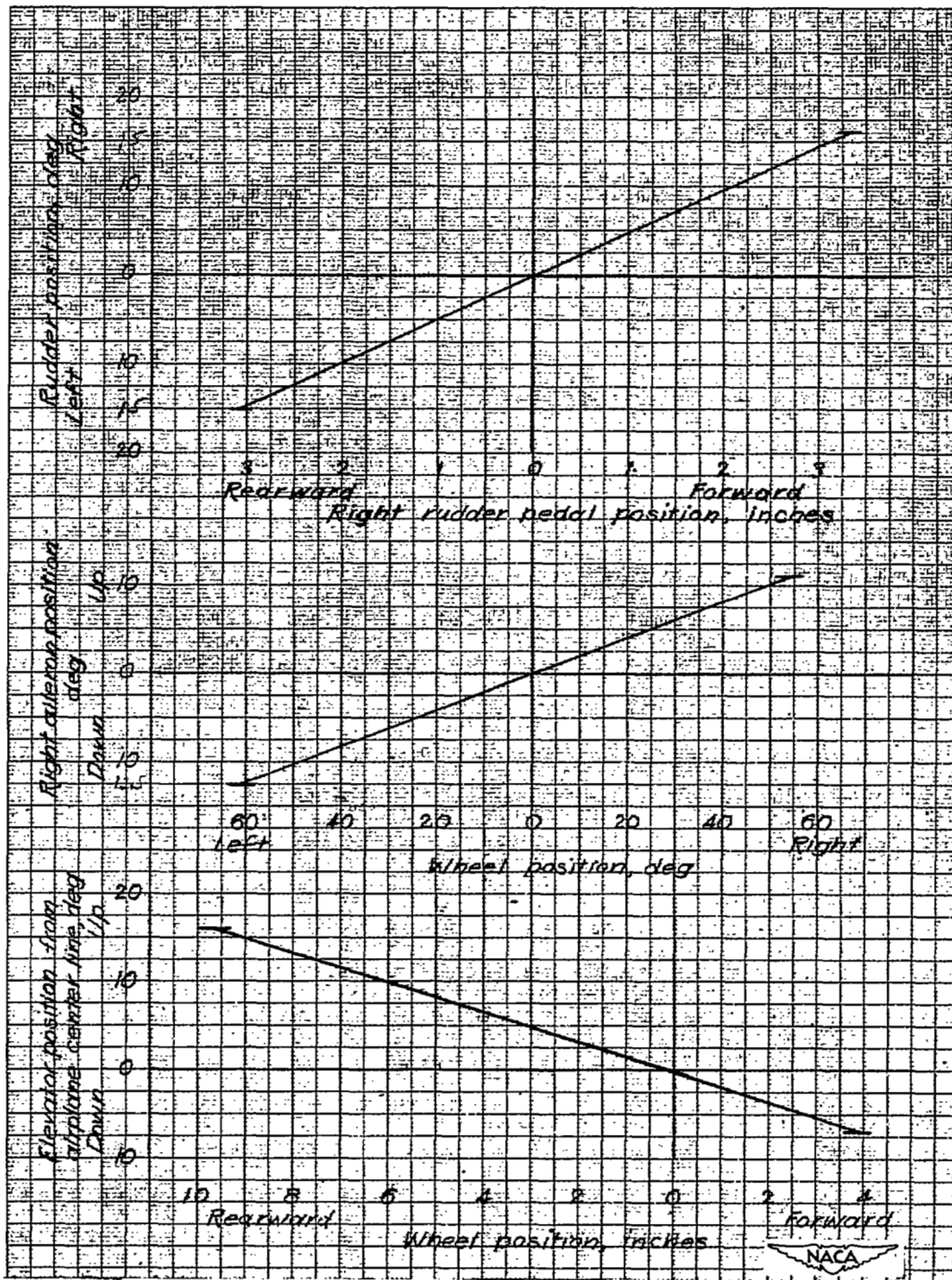

Figure 3.- Variation of control-surface deflection with pilot's control position. XS-1 airplane.

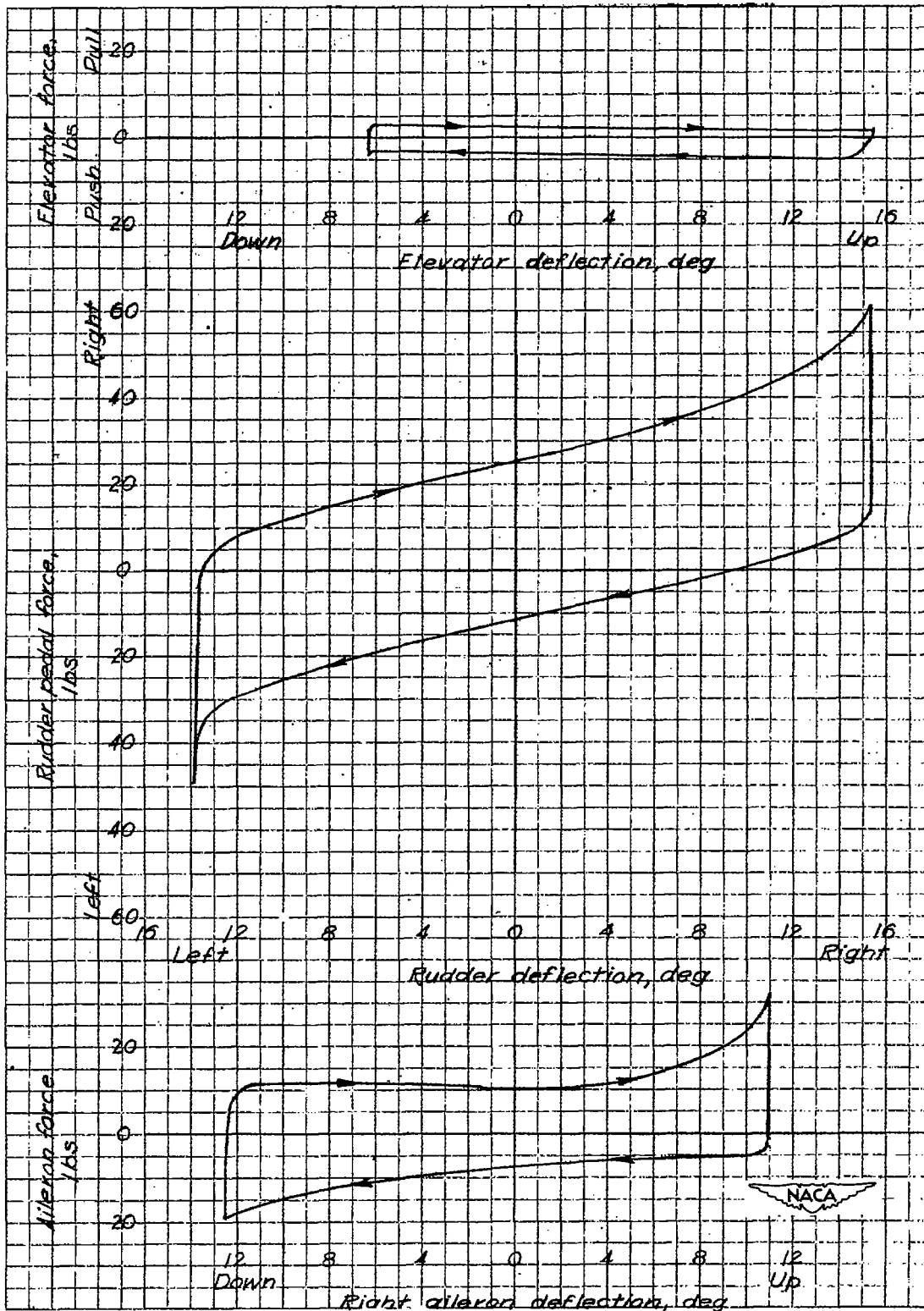

Figure 4.- Control forces required to deflect control surfaces under no load on the ground. XS-1 airplane.

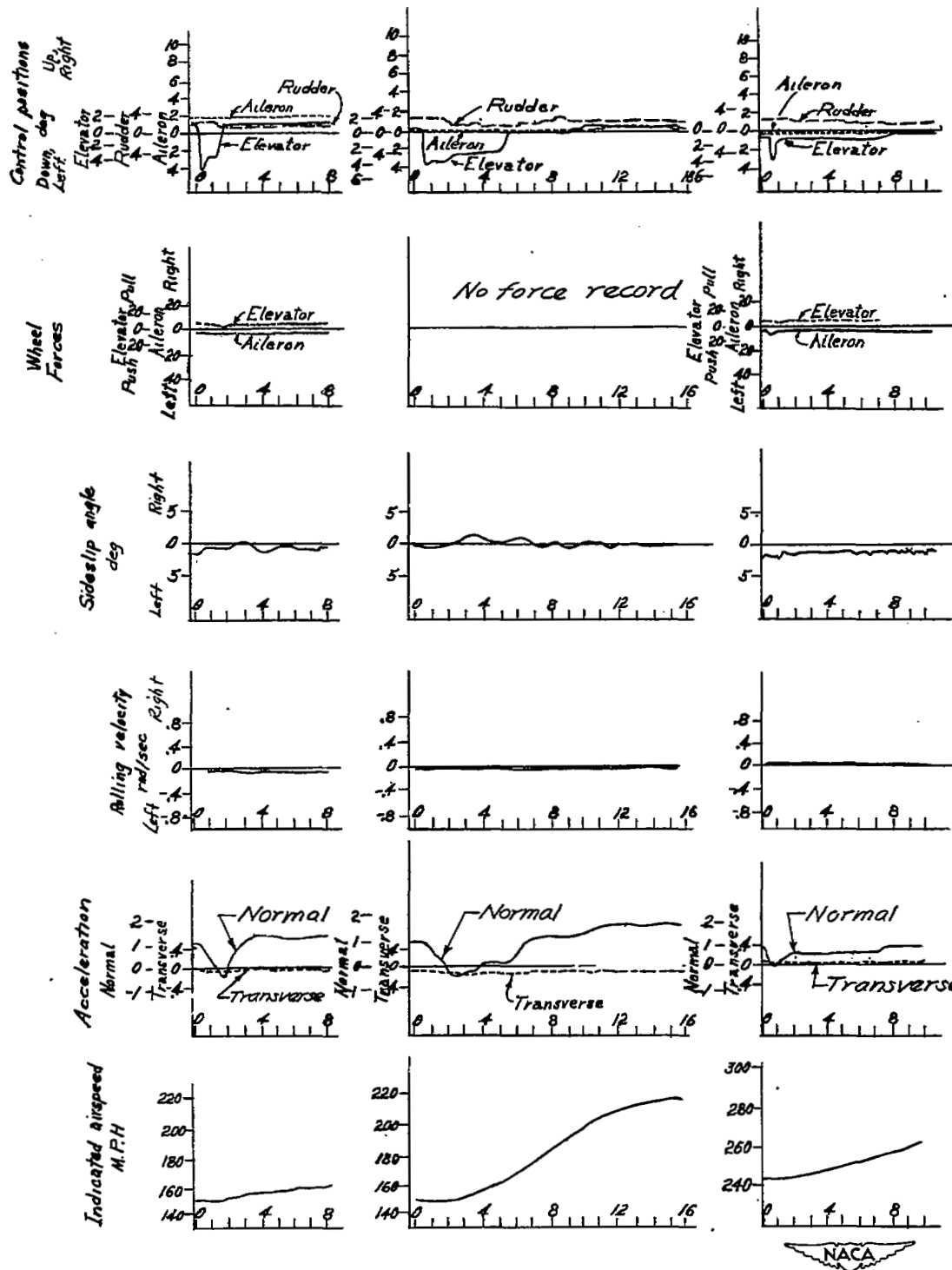

Figure 5.- Time histories of abrupt deflection and release of elevator control. XS-1 airplane.  $\frac{W}{S} = 32.5 \text{ lb/sq ft.}$



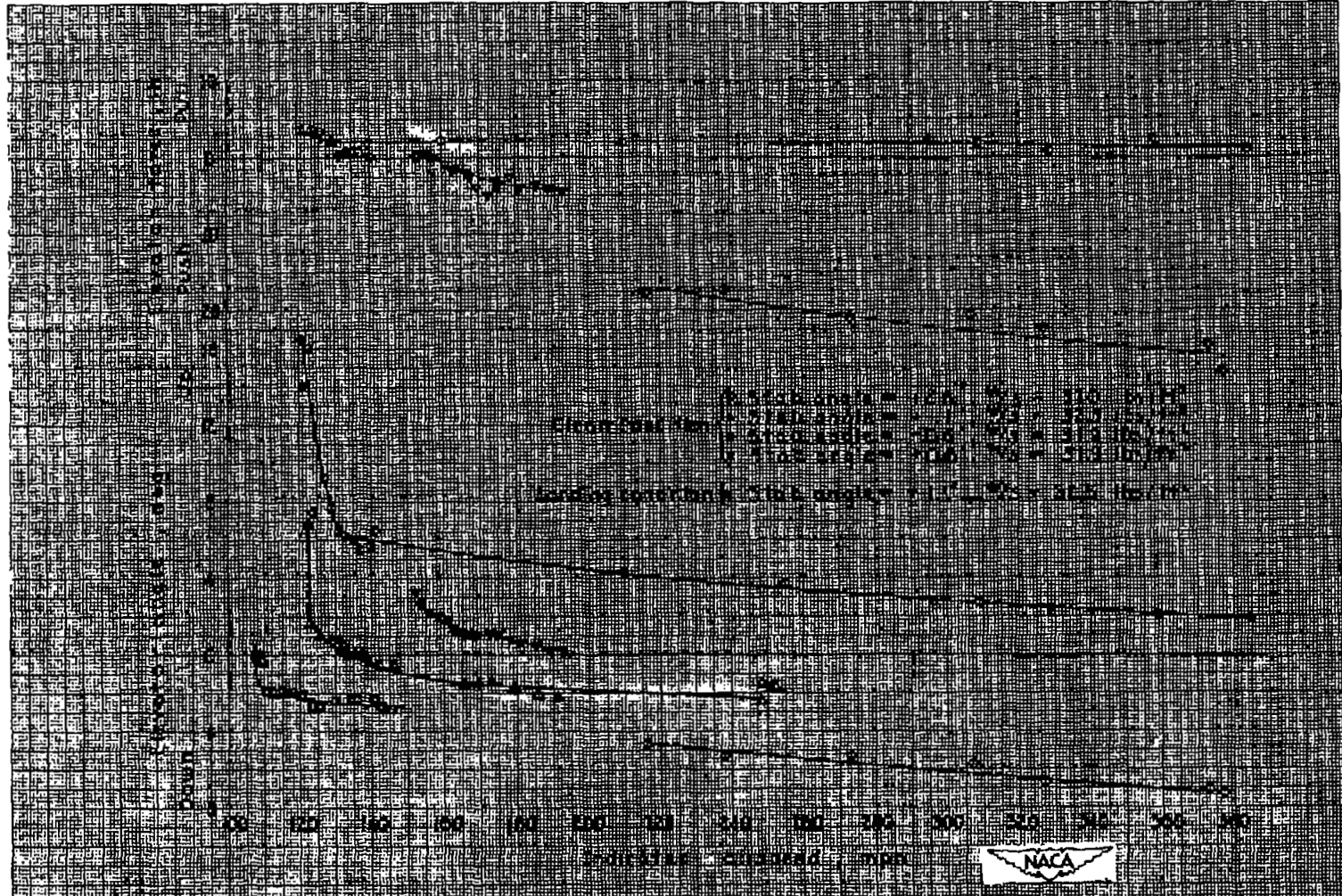

Figure 6.- Variation of elevator stick force and position required for trim with indicated airspeed as measured in steady gliding flight at various wing loadings and stabilizer positions. Center-of-gravity location at approximately 25 percent M.A.C. XS-1 airplane with 10-percent-thick wing.

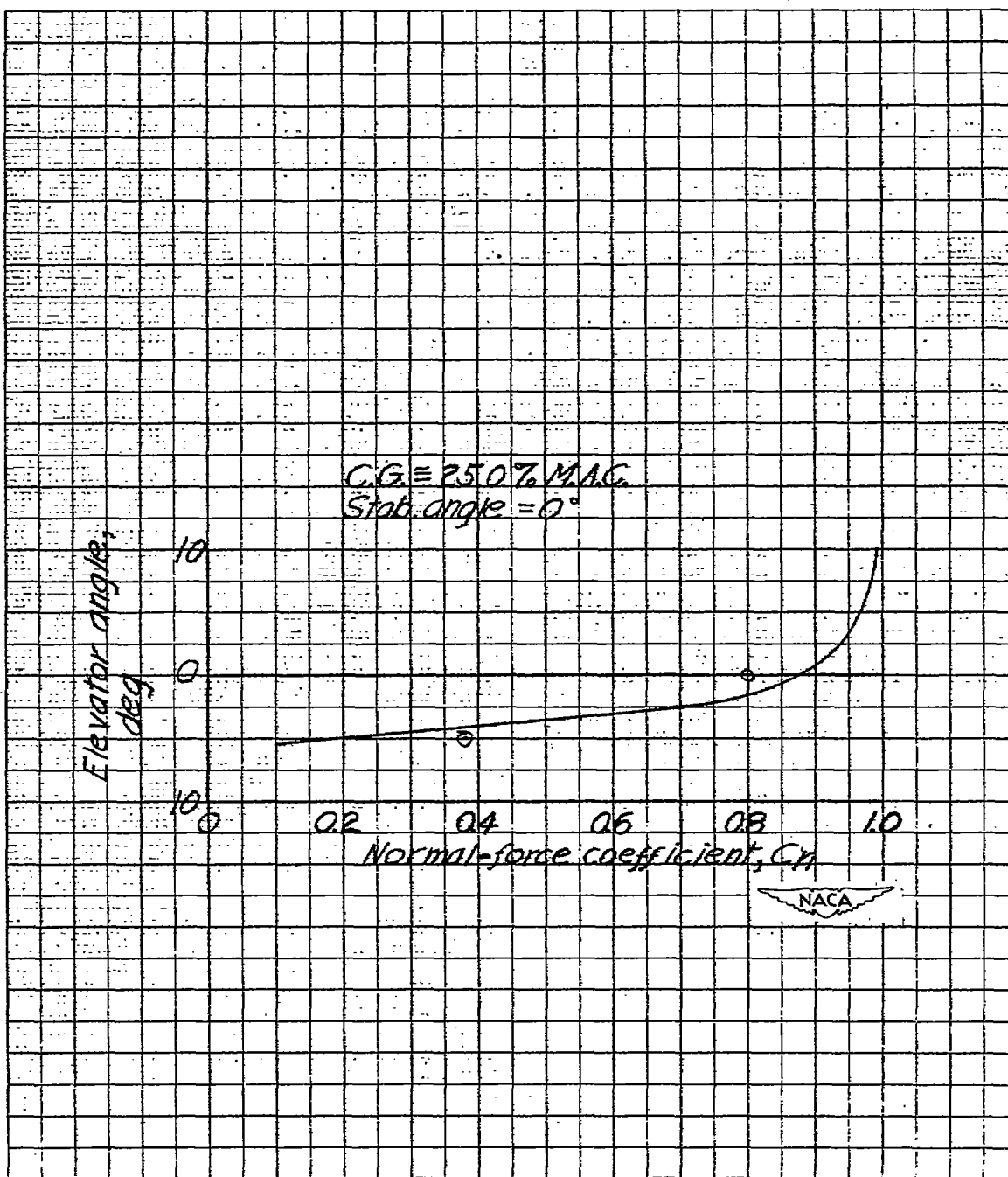

Figure 7.- Variation of elevator position, corrected to zero stabilizer position, required for trim with normal-force coefficient for steady gliding flight with flaps and gear up. Center-of-gravity location at approximately 25 percent M.A.C.; XS-1 airplane with 10-percent-thick wing.



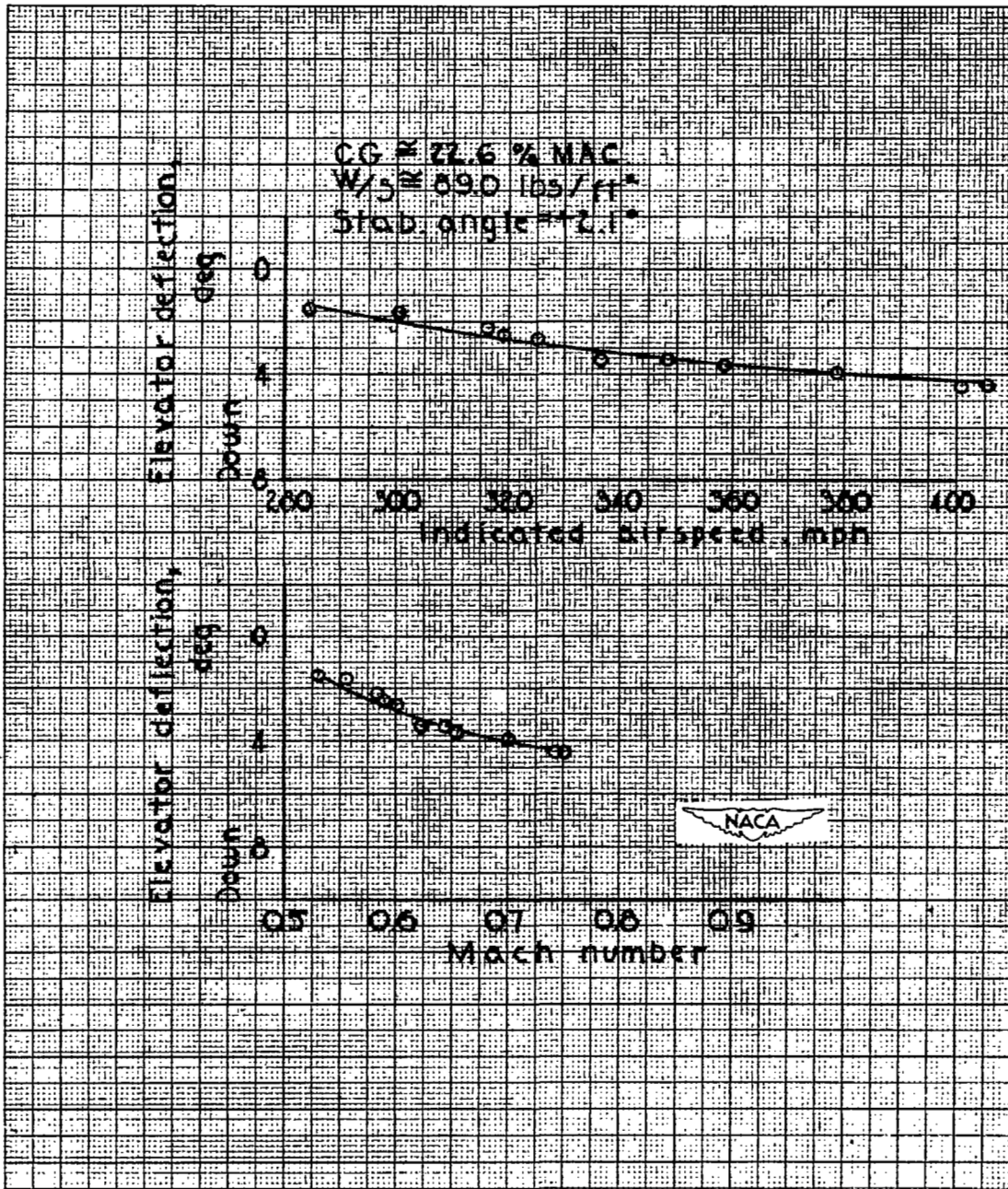

Figure 8.- Variation of elevator position with indicated airspeed and Mach number for trim in steady powered flight. XS-1 airplane with 10-percent-thick wing. Center of gravity approximately 22.6 percent M.A.C.;  $\frac{W}{S} = 89$  lb/sq ft. Stabilizer position 2.1°.

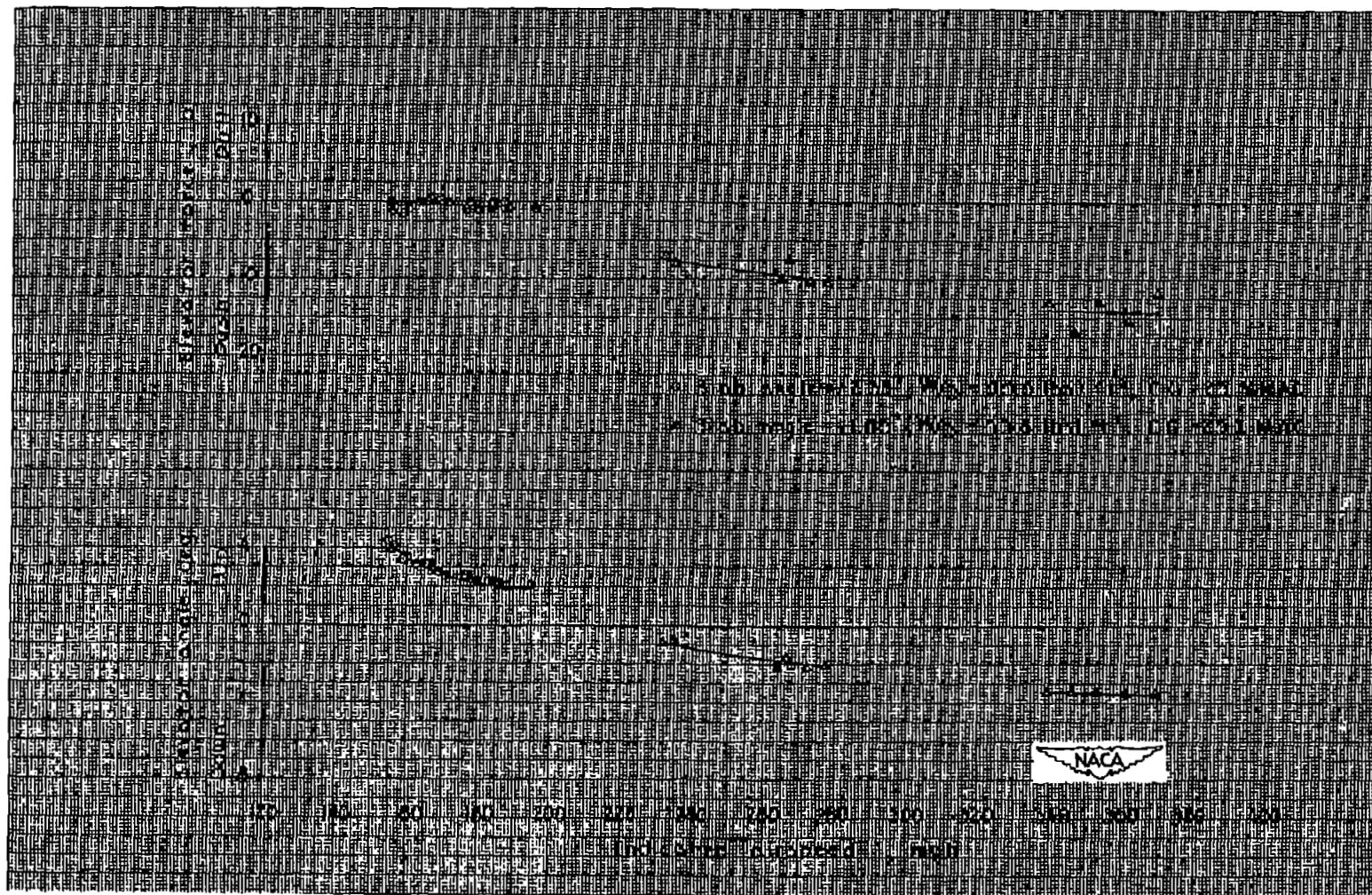

Figure 9.- Variation of elevator stick force and position with indicated airspeed for trim in steady gliding flight with several stabilizer settings. XS-1 airplane with 8-percent-thick wing. Center of gravity 25 percent M.A.C.;  $\frac{W}{S} = 53.8$  lb/sq ft.

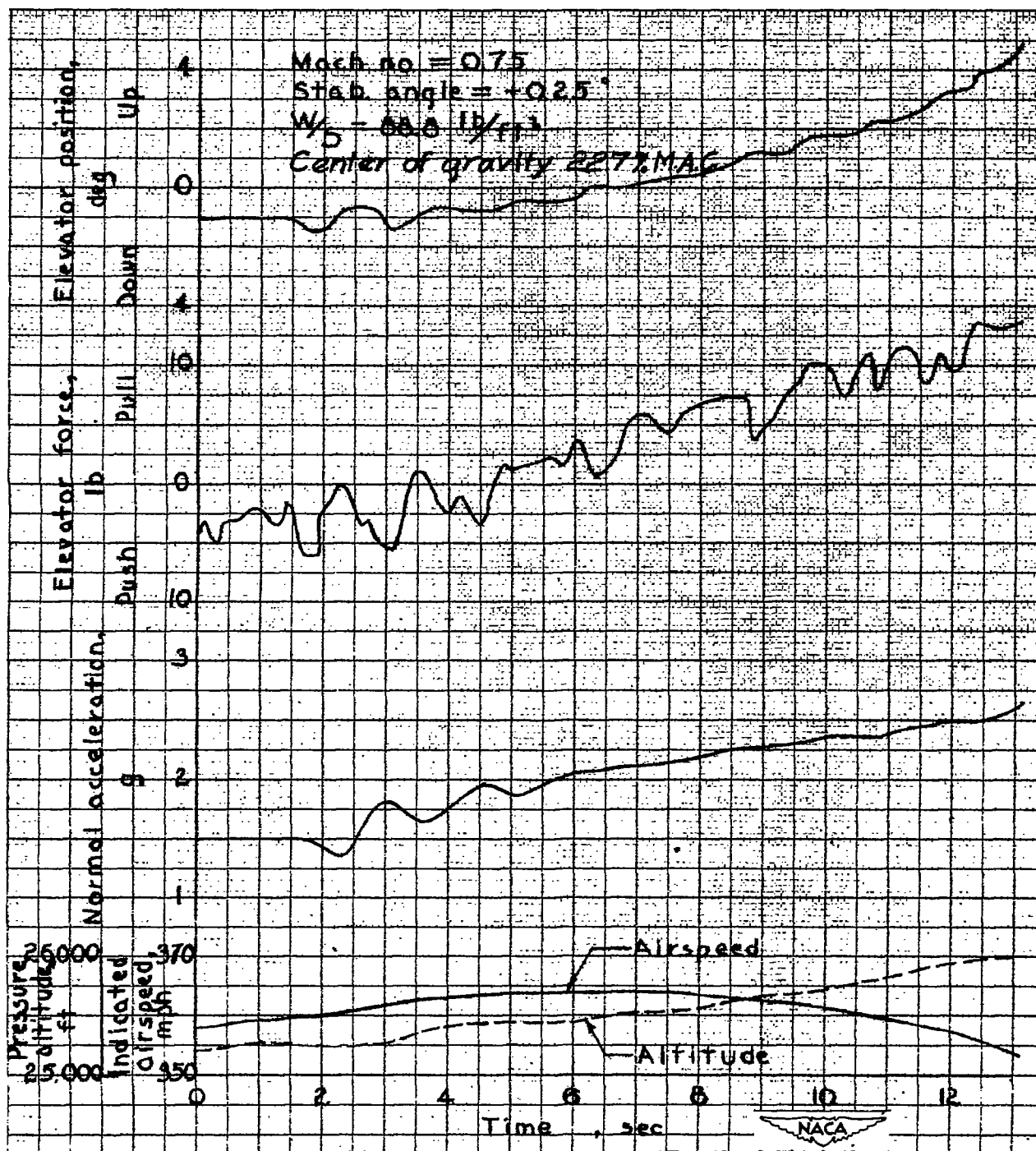

Figure 10.- Time history of a power-on turn with slowly increasing normal acceleration at a Mach number of about 0.75. XS-1 airplane with 10-percent-thick wing.

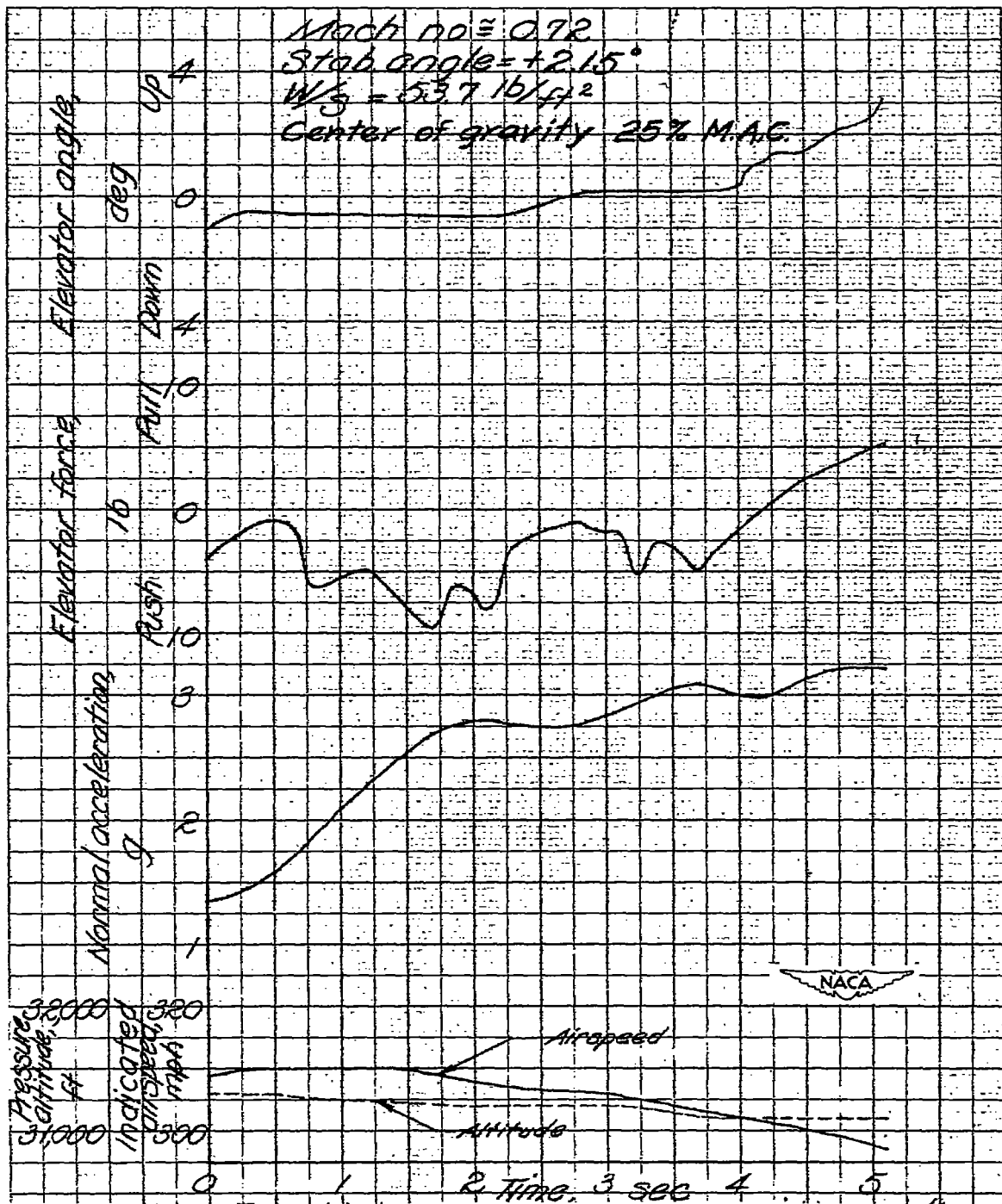
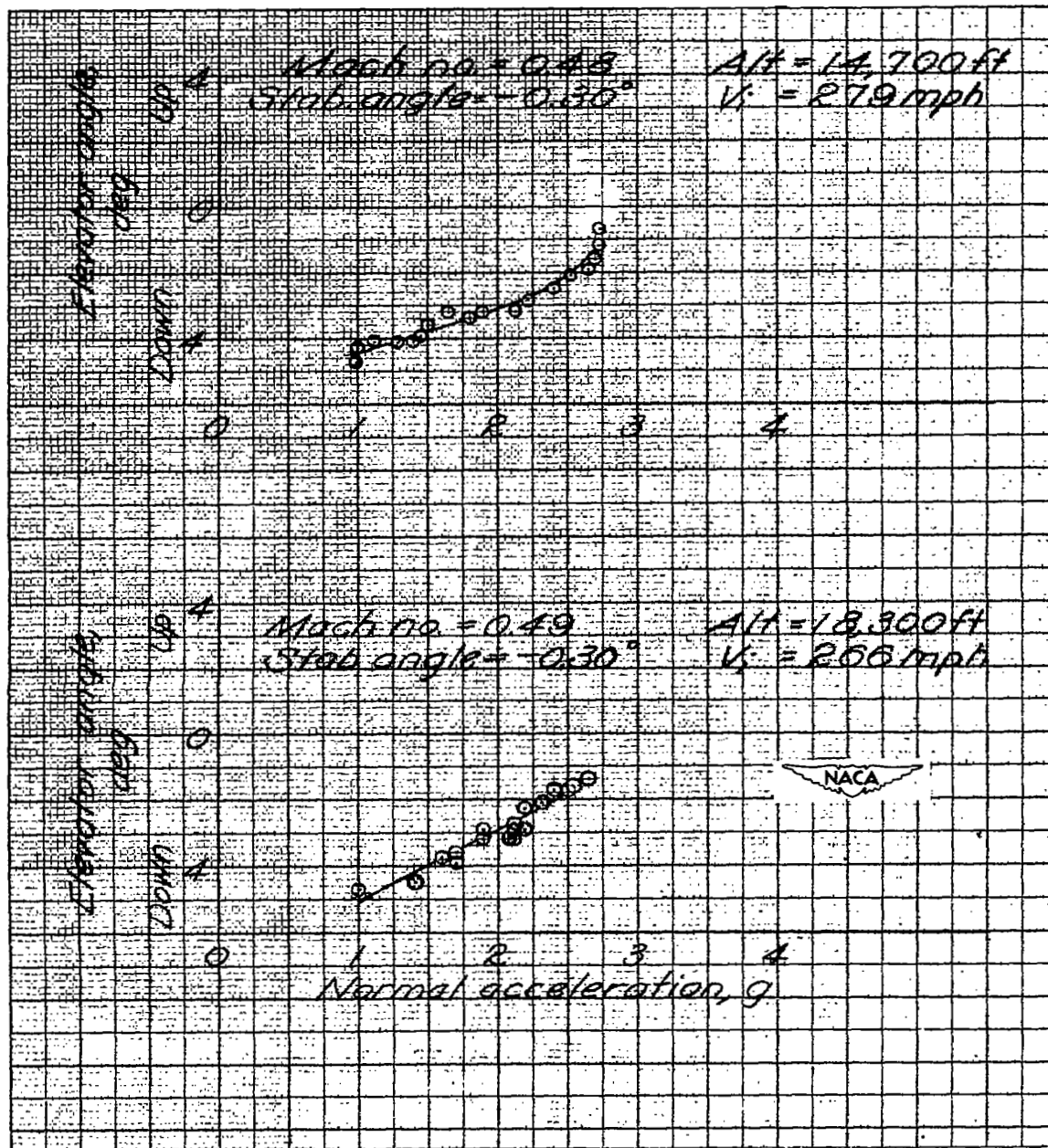

Figure 11.- Time history of a power-off turn with rapidly increasing normal acceleration at a Mach number of about 0.72. XS-1 airplane with 8-percent-thick wing.



(a) Variation of elevator position with normal acceleration.

Figure 12.- Results obtained in turns at Mach numbers of 0.48 and 0.49, XS-1 airplane with 10-percent-thick wing. Gliding flight; center of gravity, 25.3 percent M.A.C.;  $\frac{W}{S} = 51.9$  lb/sq ft.



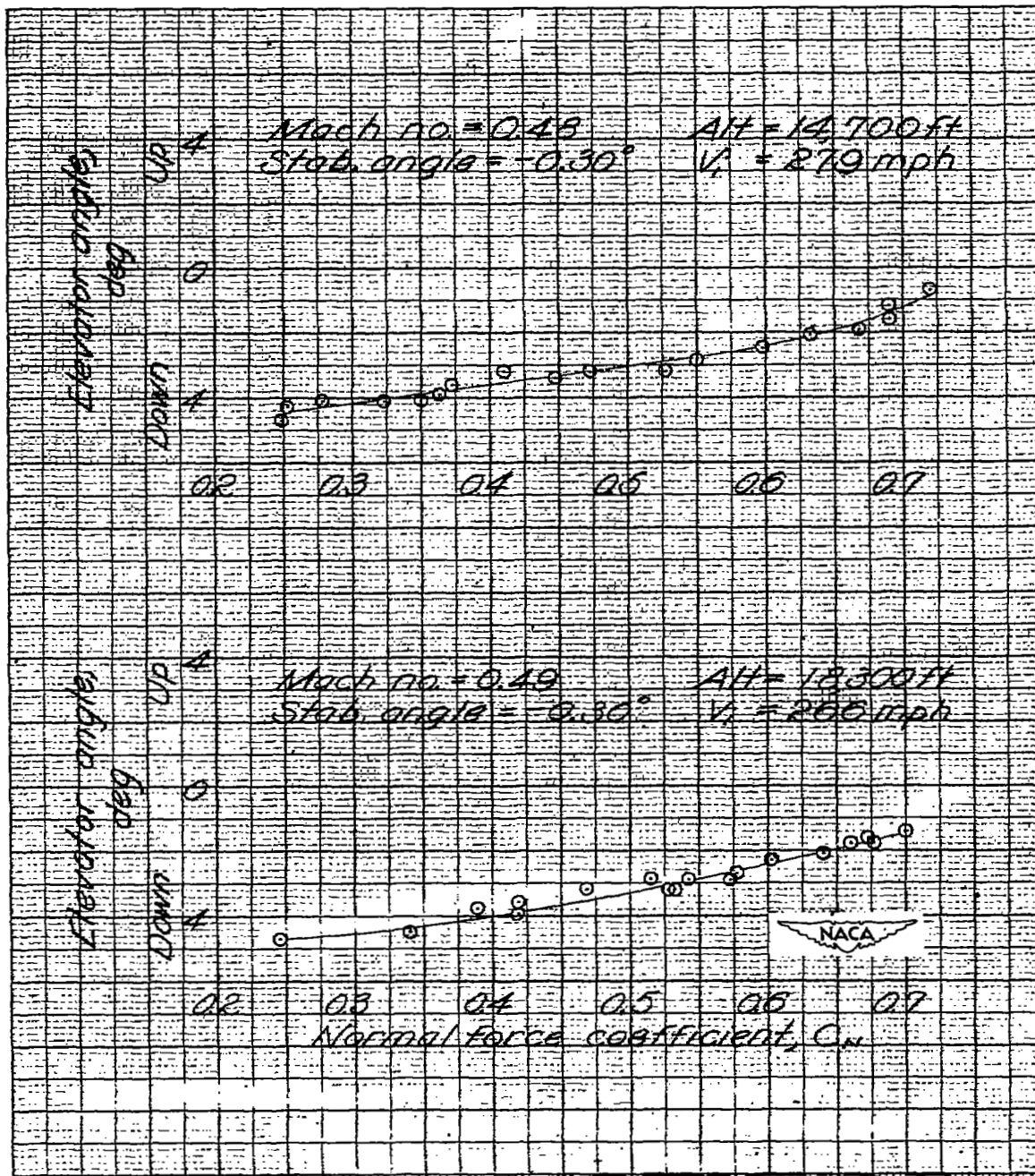

(b) Variation of elevator position with normal-force coefficient.

Figure 12.- Continued.

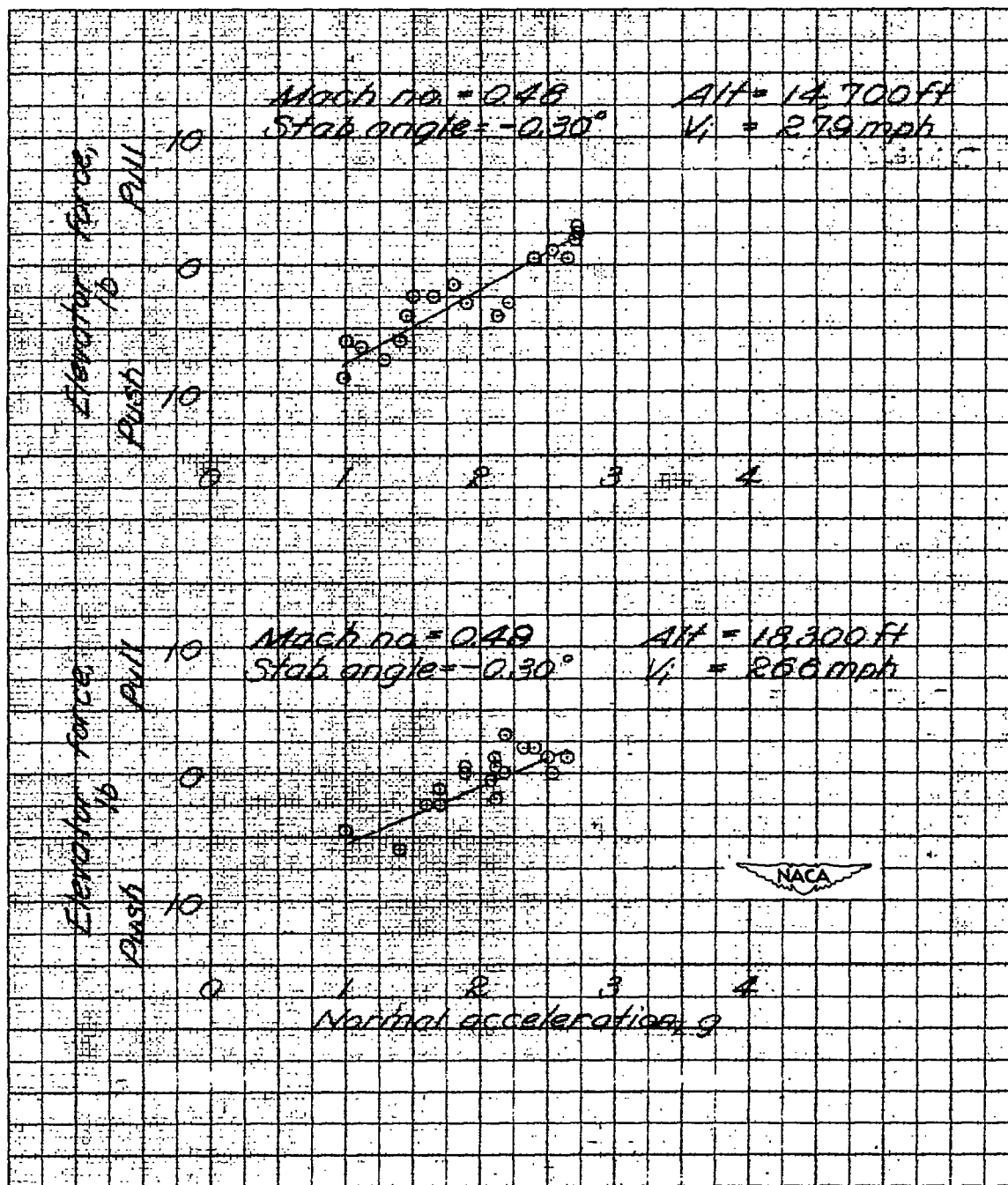

(c) Variation of elevator wheel force with normal acceleration.

Figure 12.- Concluded.

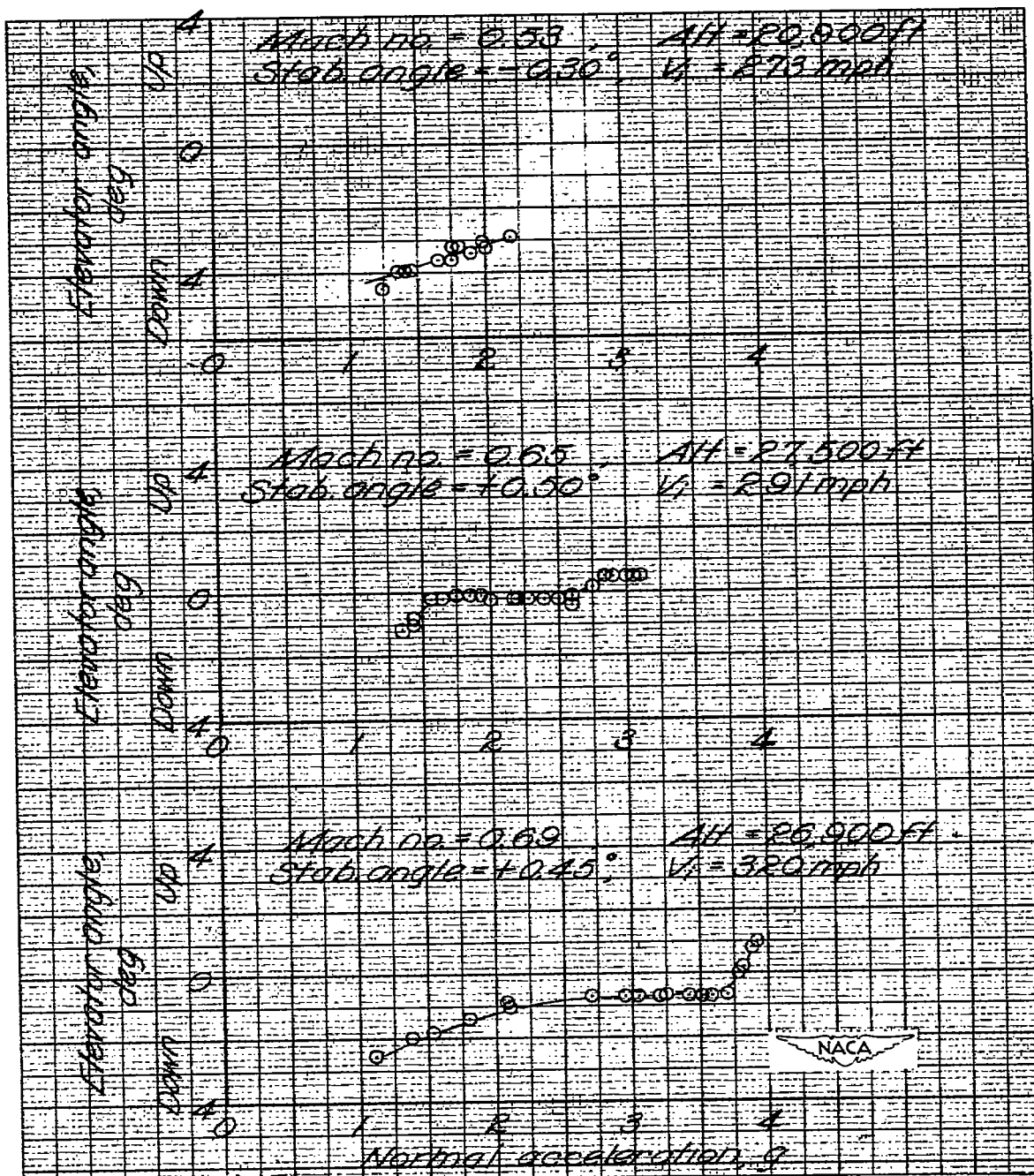

(a) Variation of elevator position with normal acceleration.

Figure 13.- Results obtained in turns at Mach numbers of 0.53, 0.65, and 0.69. XS-1 airplane with 10-percent-thick wing. Gliding flight; center of gravity, 25.3 percent M.A.C.;  $\frac{W}{S} = 51.9$  lb/sq ft.



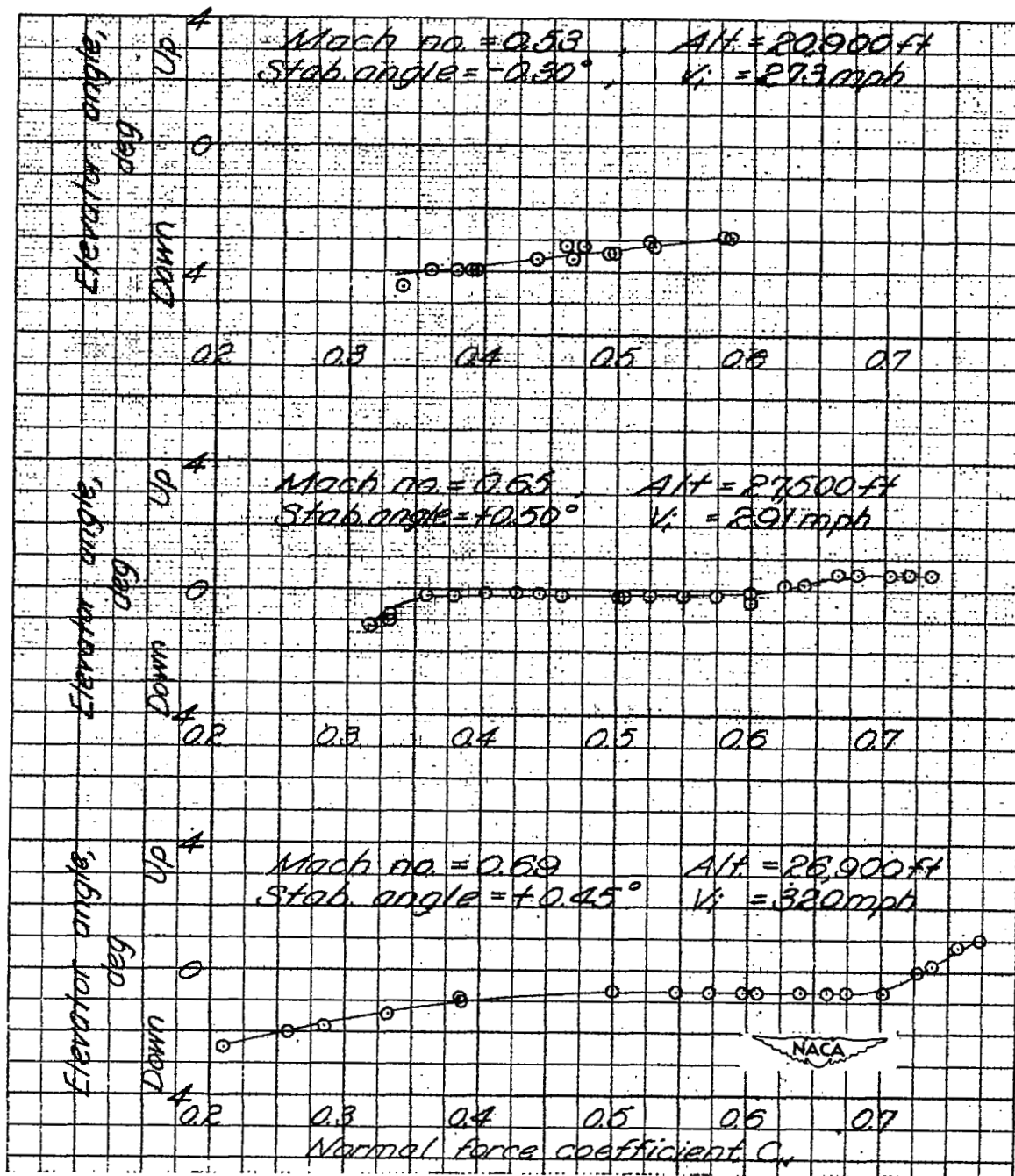

(b) Variation of elevator position with normal-force coefficient.

Figure 13.- Continued.

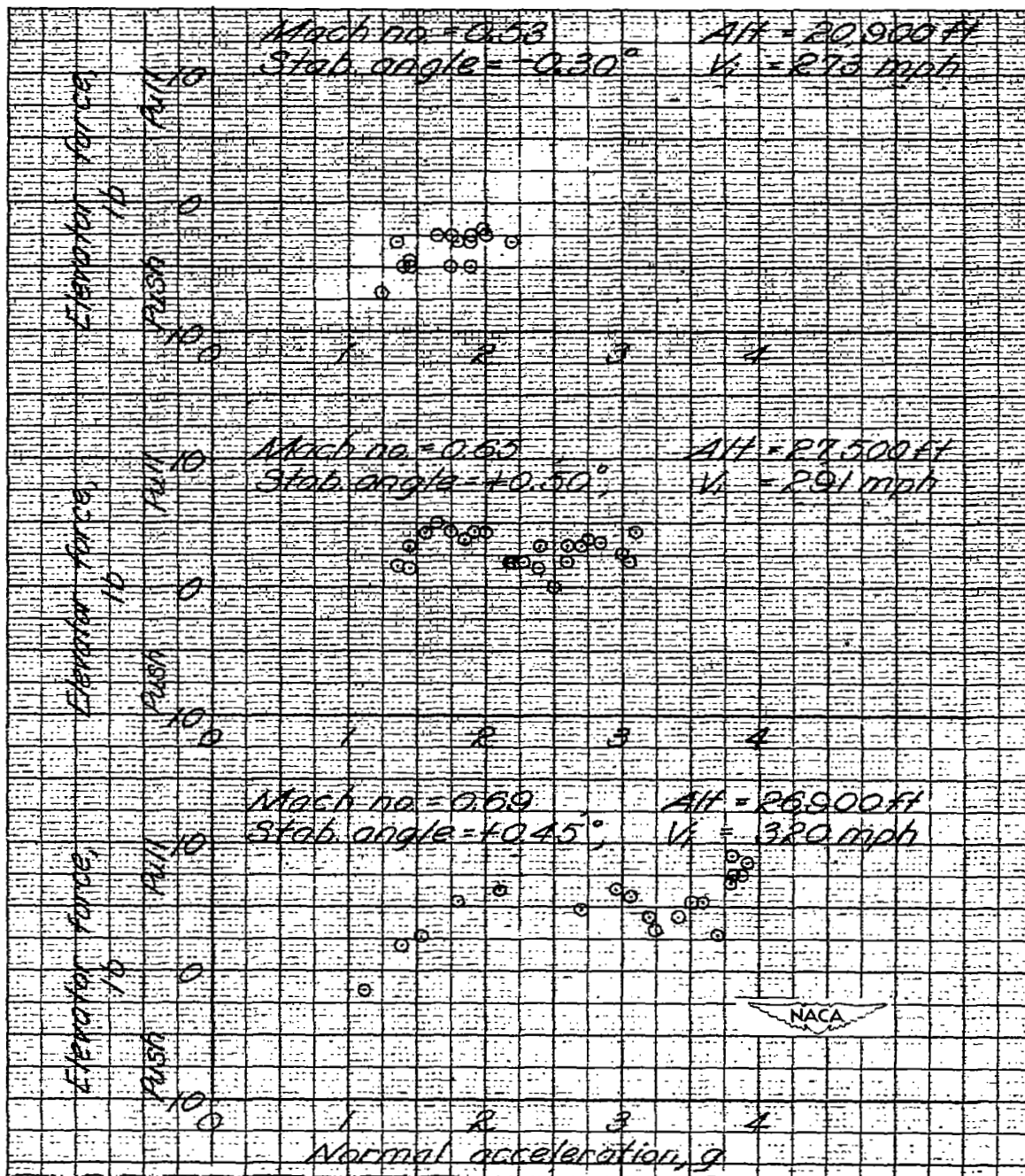

(c) Variation of elevator wheel force with normal acceleration.

Figure 13.- Concluded.

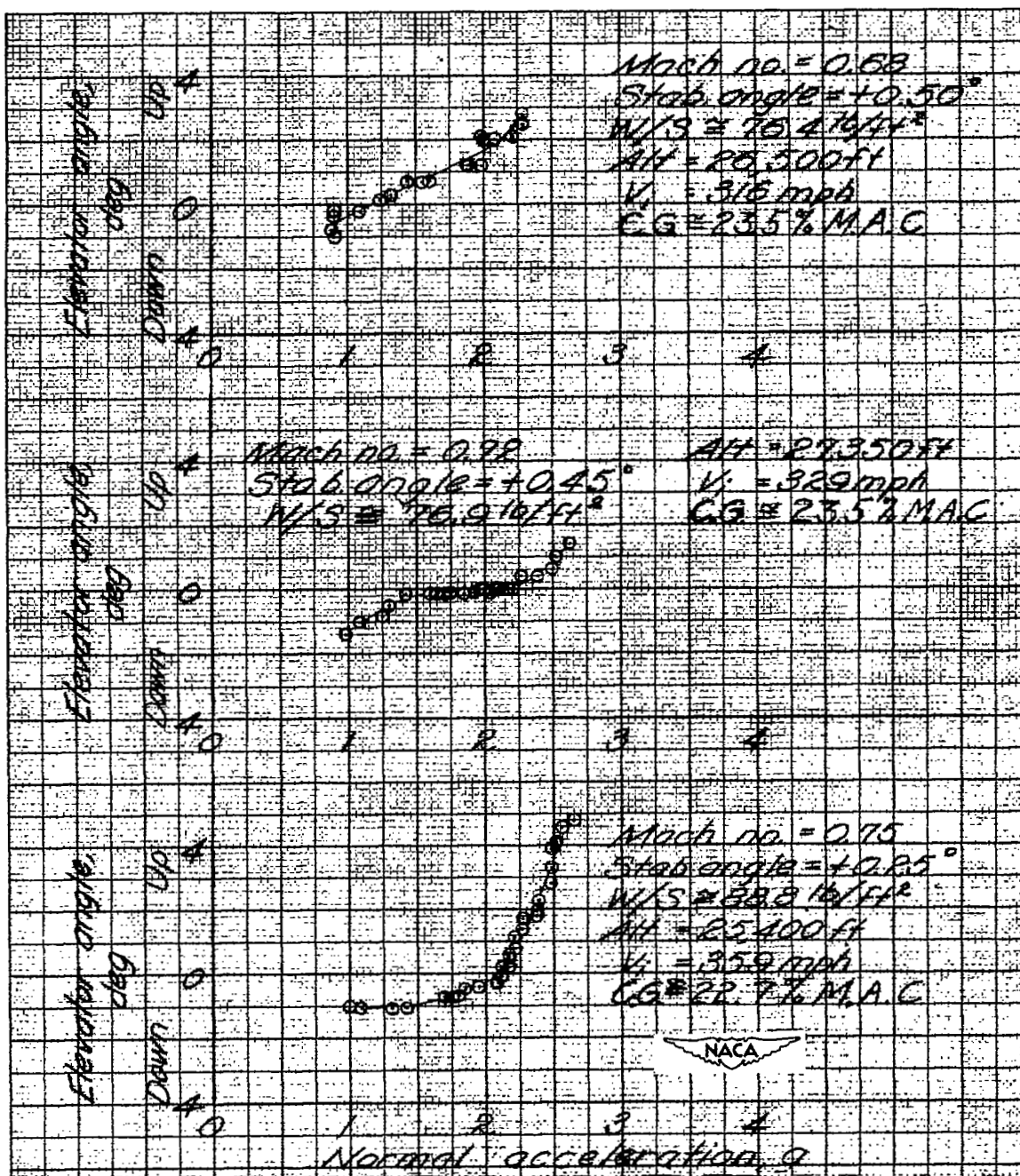

(a) Variation of elevator position with normal acceleration.

Figure 14.- Results obtained in turns at Mach numbers of 0.68, 0.72, and 0.75 with power on. XS-1 airplane with 10-percent-thick wing.

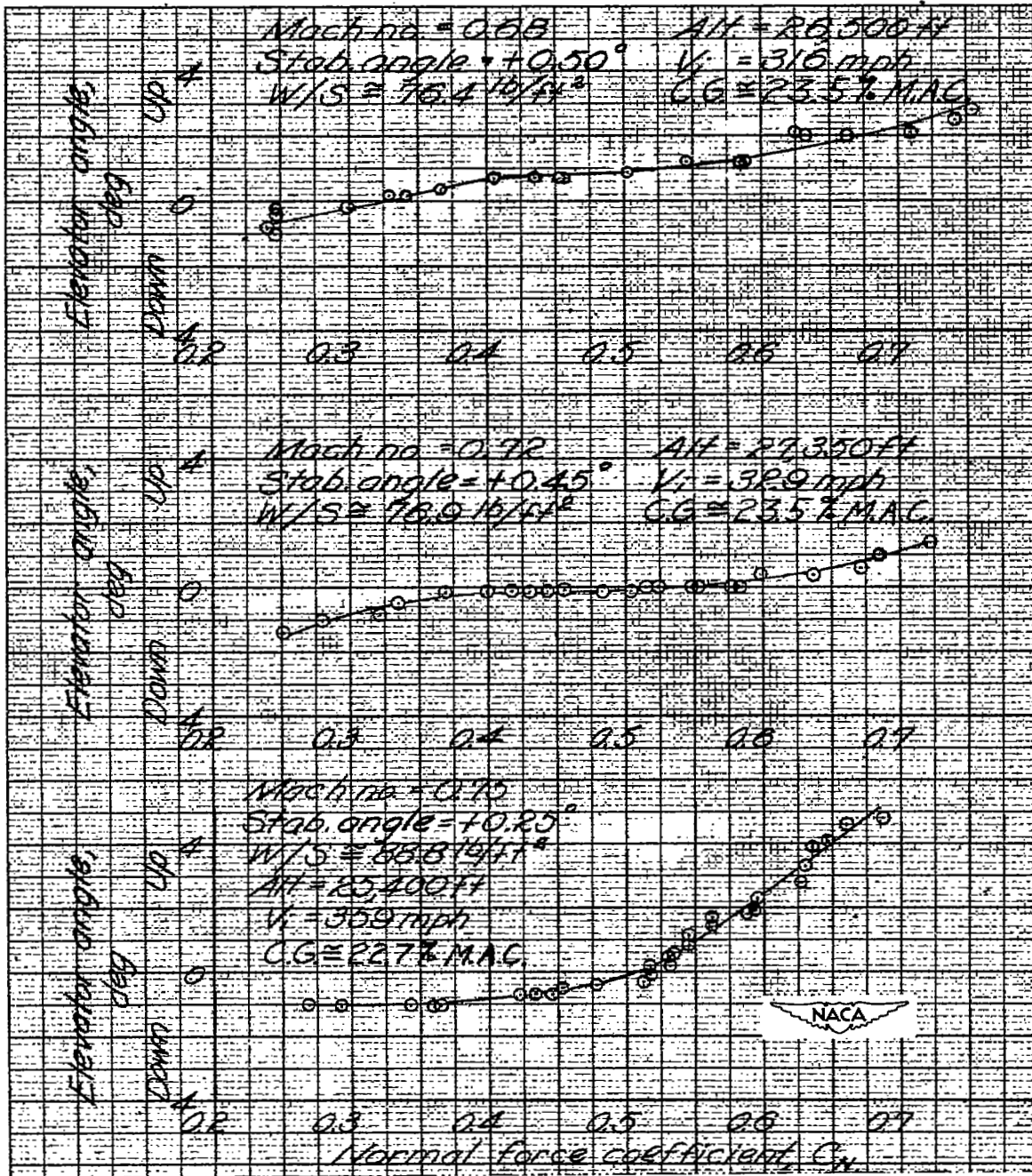

(b) Variation of elevator position with normal-force coefficient.

Figure 14.- Continued.

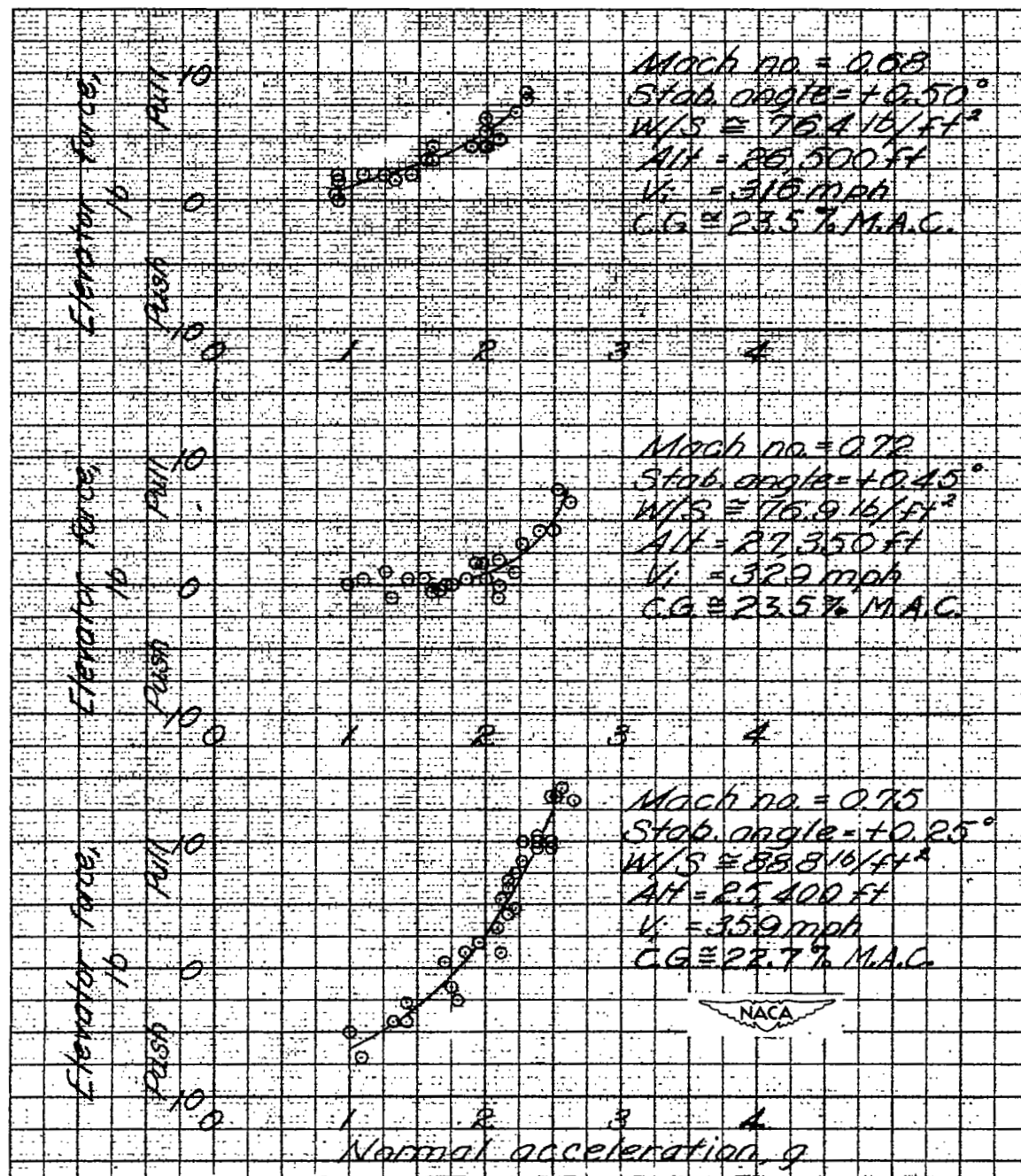

(c) Variation of elevator wheel force with normal acceleration.

Figure 14.- Concluded.



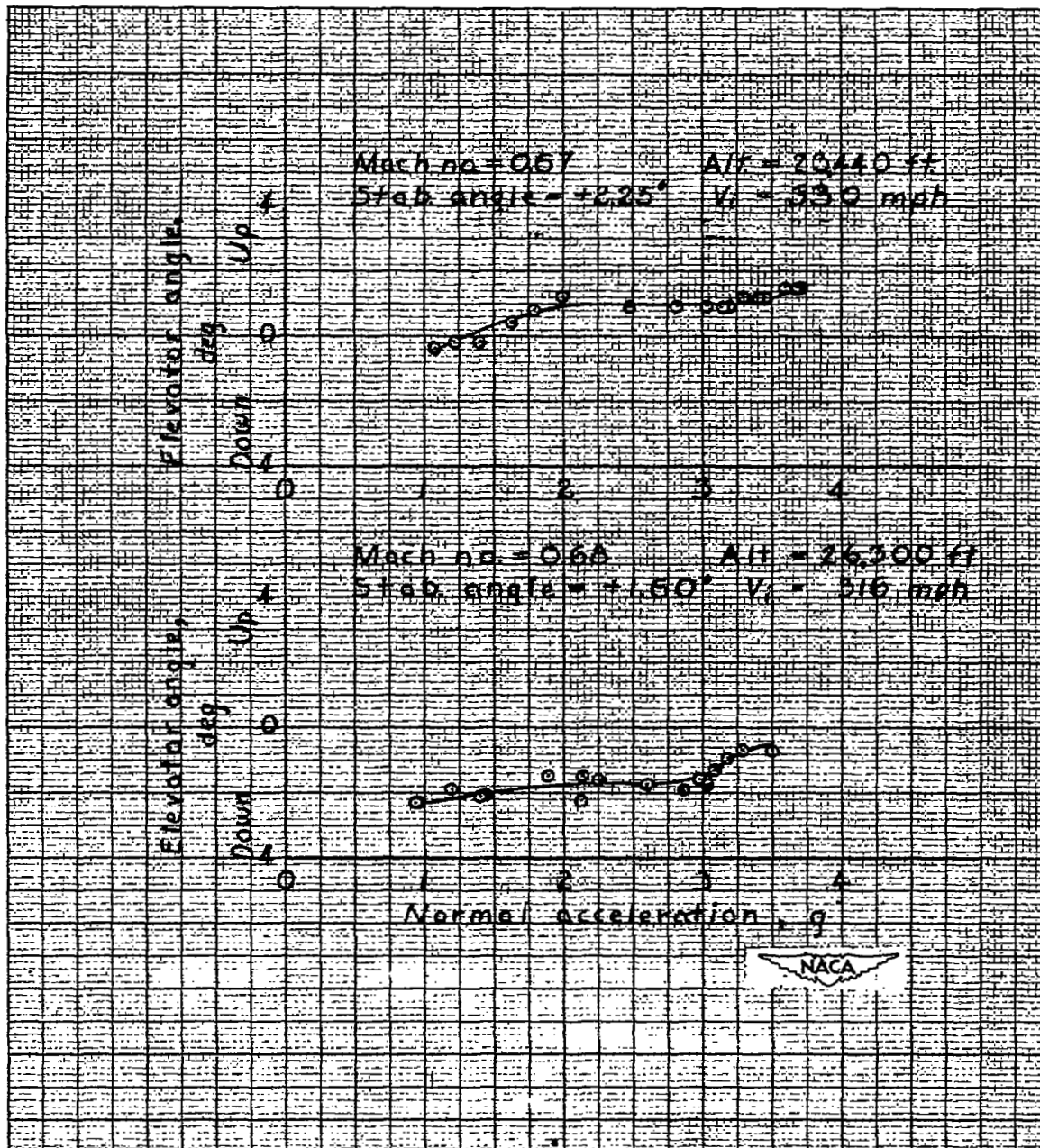

(a) Variation of elevator position with normal acceleration.

Figure 15.- Results obtained in turns at Mach numbers of 0.67, 0.68, XS-1 airplane with 8-percent-thick wing. Gliding flight; center of gravity, 25 percent M.A.C.;  $\frac{W}{S} = 53.8$  lb/sq ft.

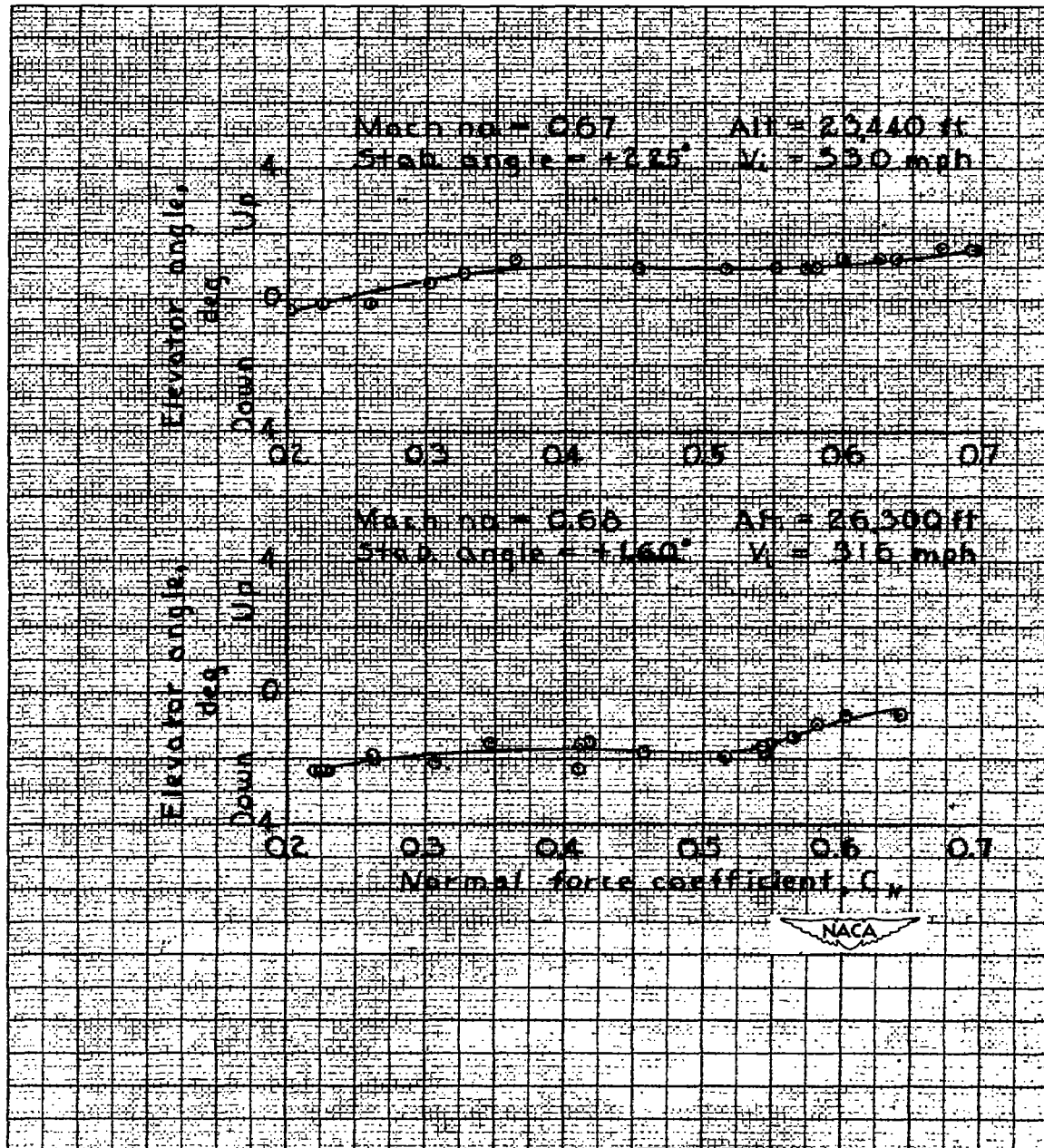

(b) Variation of elevator deflection with normal-force coefficient.

Figure 15.- Continued.

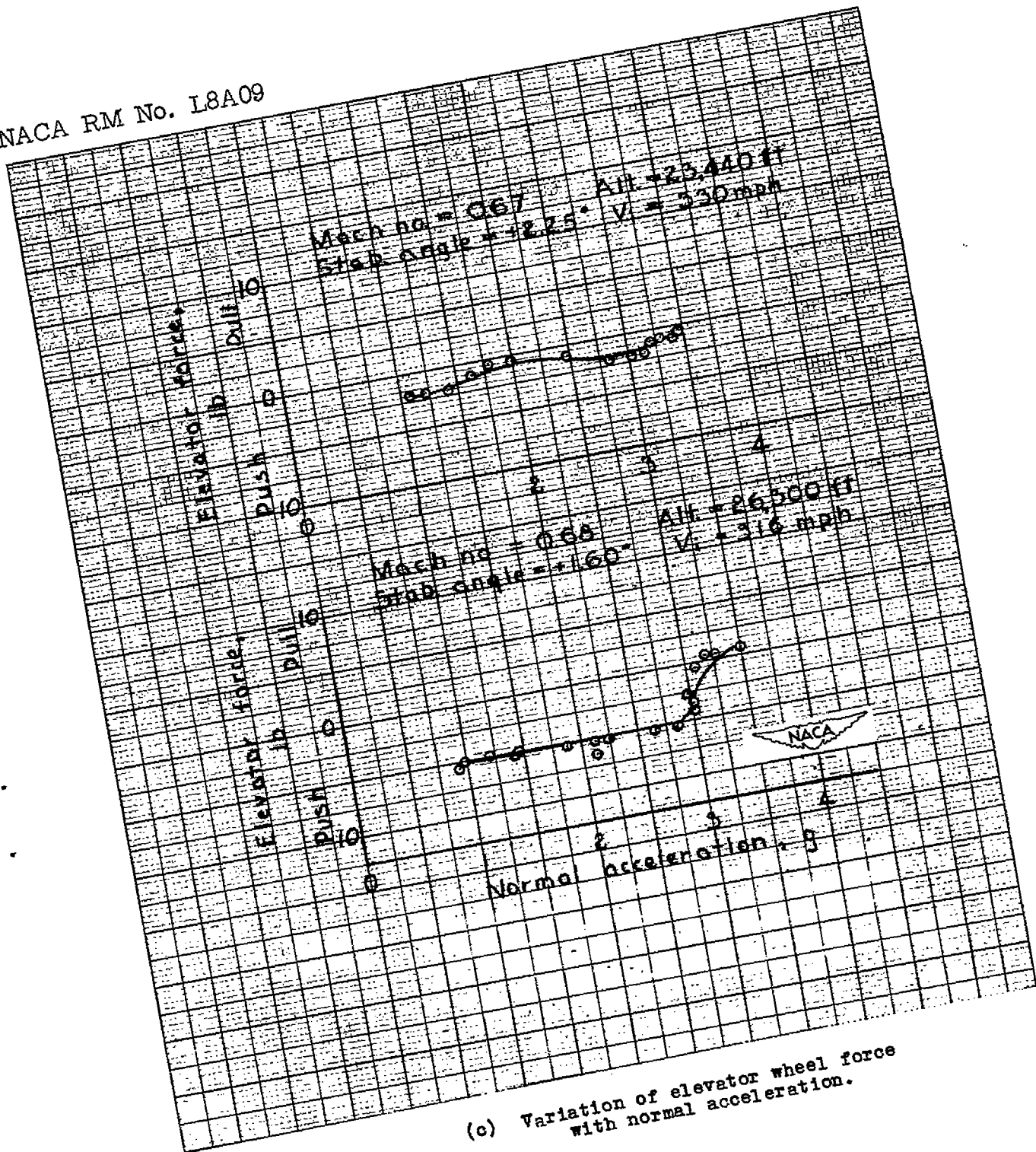

(c) Variation of elevator wheel force with normal acceleration.

Figure 15.- Concluded.



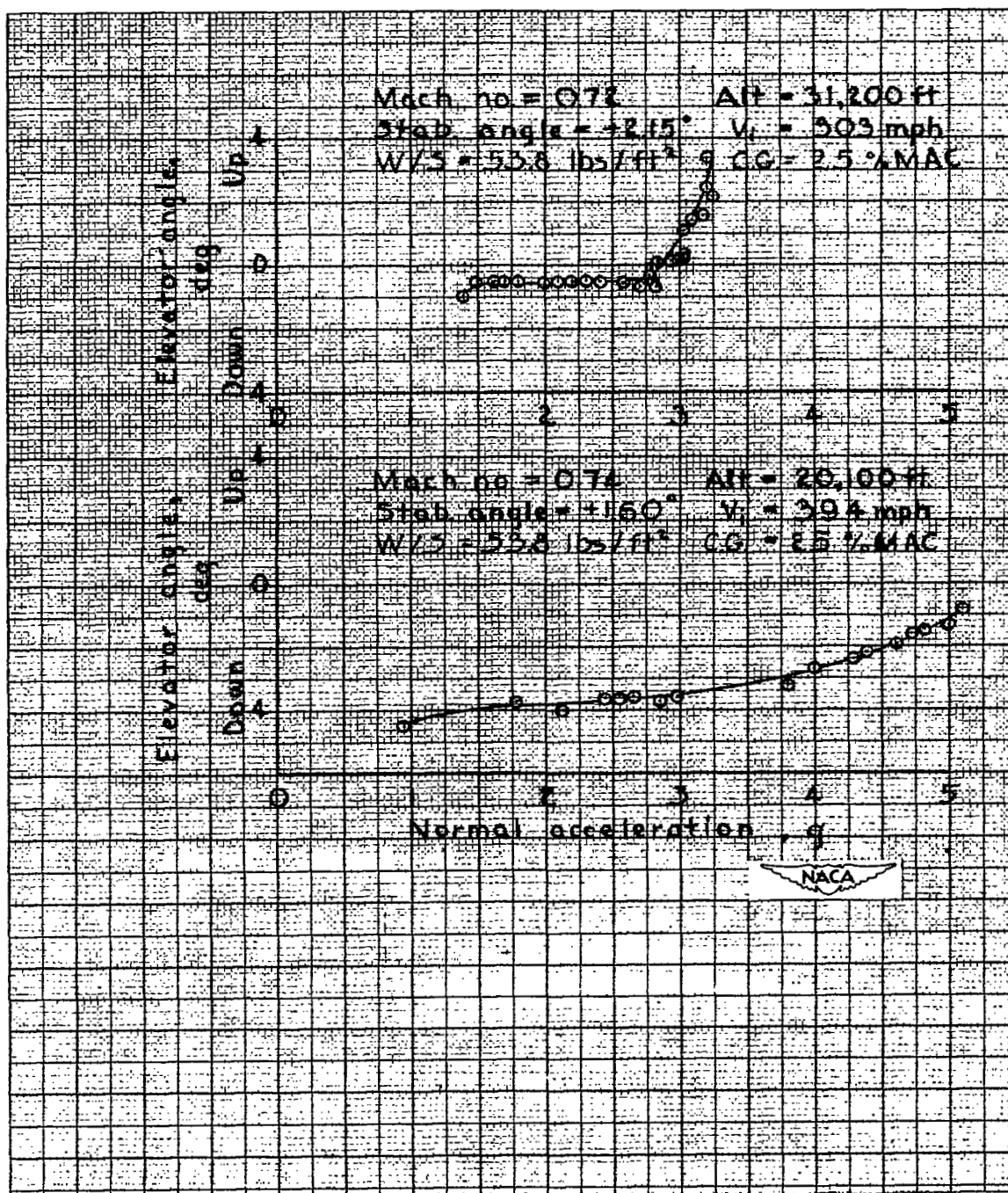

(a) Variation of elevator position with normal acceleration.

Figure 16.- Results obtained in turns made at Mach numbers of 0.72 and 0.74. XS-1 airplane with 8-percent-thick wing. Gliding flight; center of gravity, 25 percent M.A.C.;  $\frac{W}{S} = 53.8$  lb/sq ft.

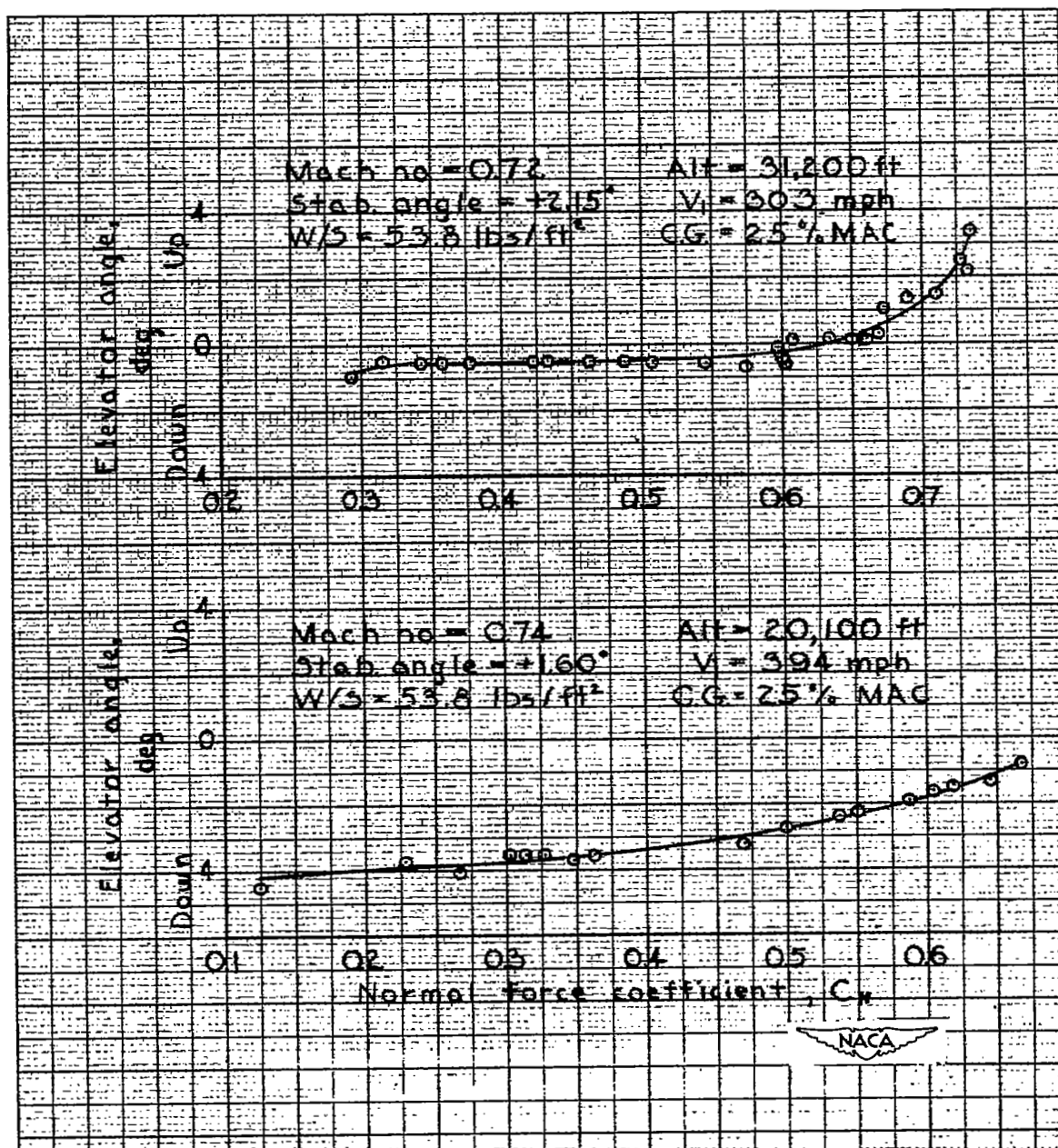

(b) Variation of elevator angle with normal-force coefficient.

Figure 16.- Continued.

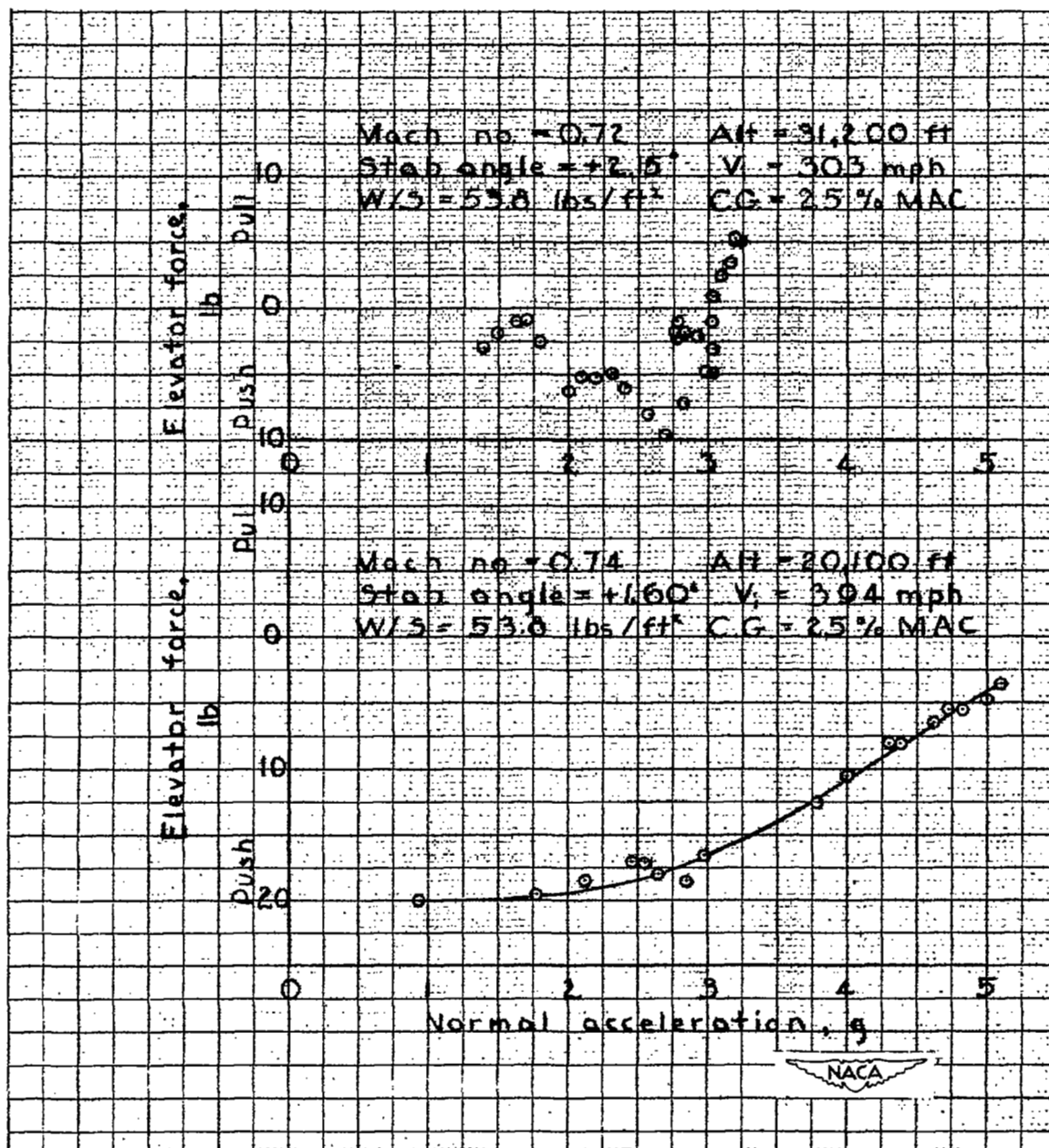

(c) Variation of elevator wheel force with normal acceleration.

Figure 16.- Concluded.

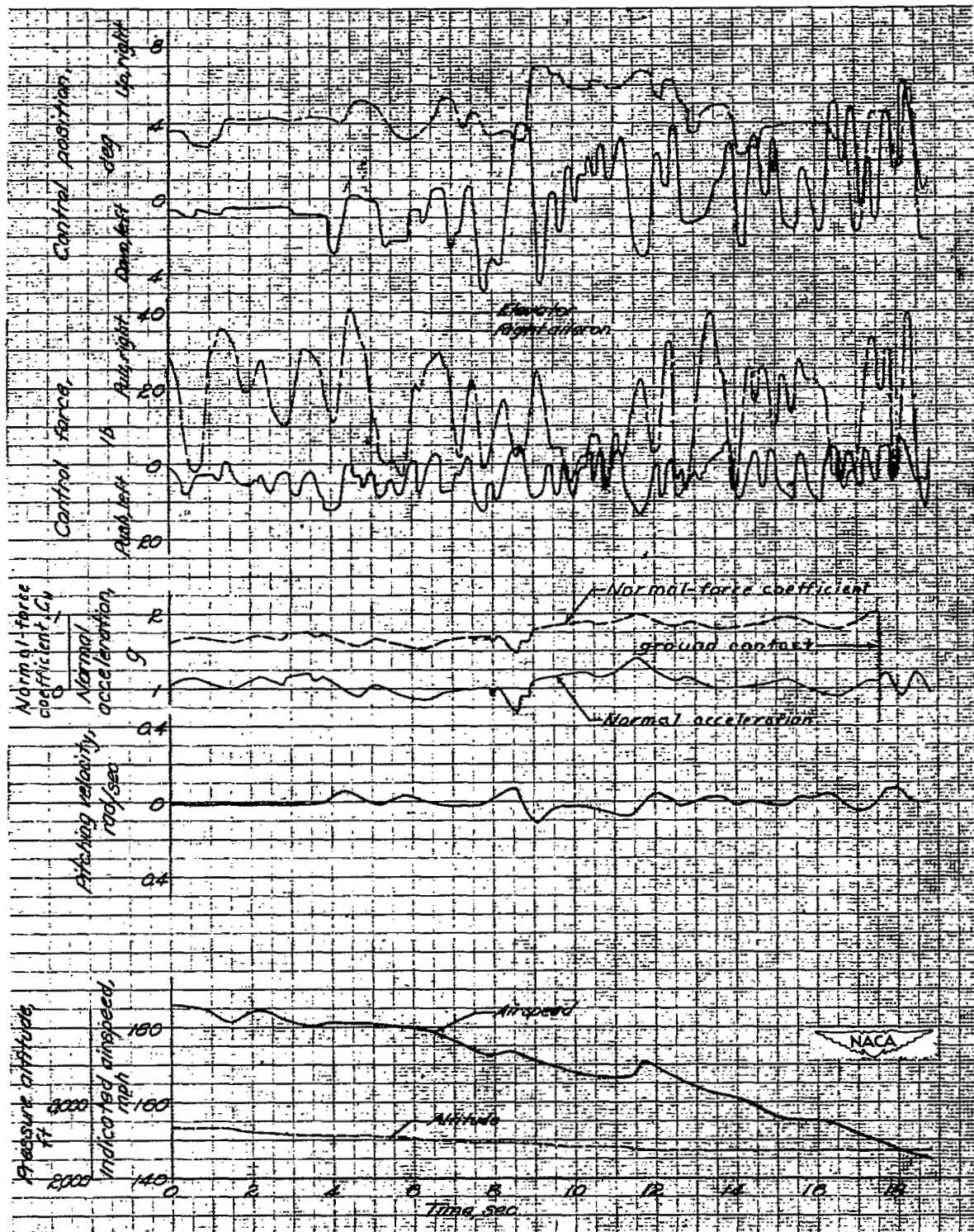

Figure 17.- Time history of a landing, XS-1 airplane with 8-percent-thick wing. Center of gravity, 25 percent M.A.C.  $\frac{W}{S} = 53.8$  lb/sq ft. Stabilizer angle,  $1.75^\circ$ .

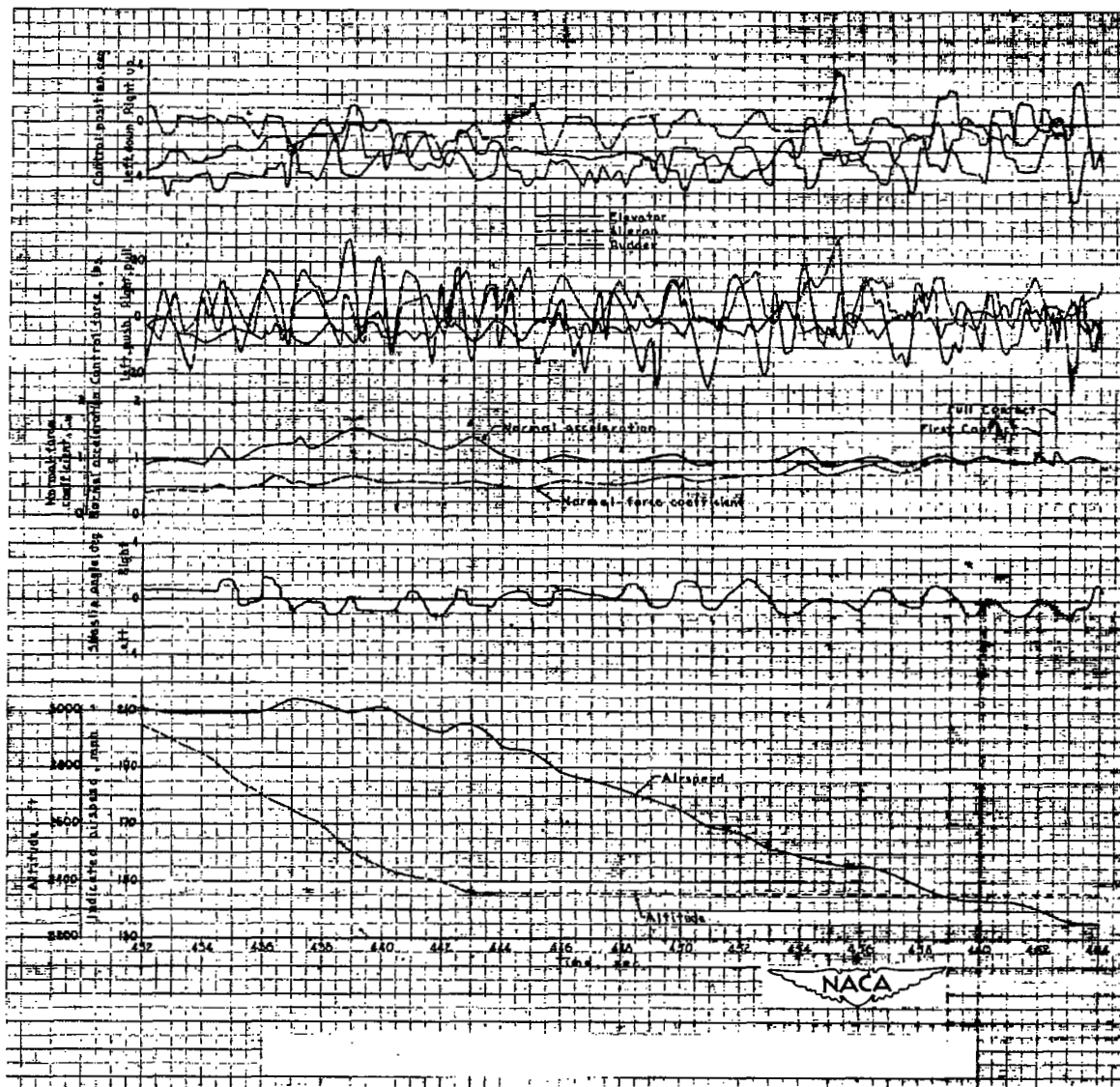

Figure 18.- Time history of a landing, XS-1 airplane with 10-percent-thick wing. Center of gravity, 25.3 percent M.A.C.

$\frac{W}{S} = 51.9$  lb/sq ft. Stabilizer setting,  $0.6^\circ$ .



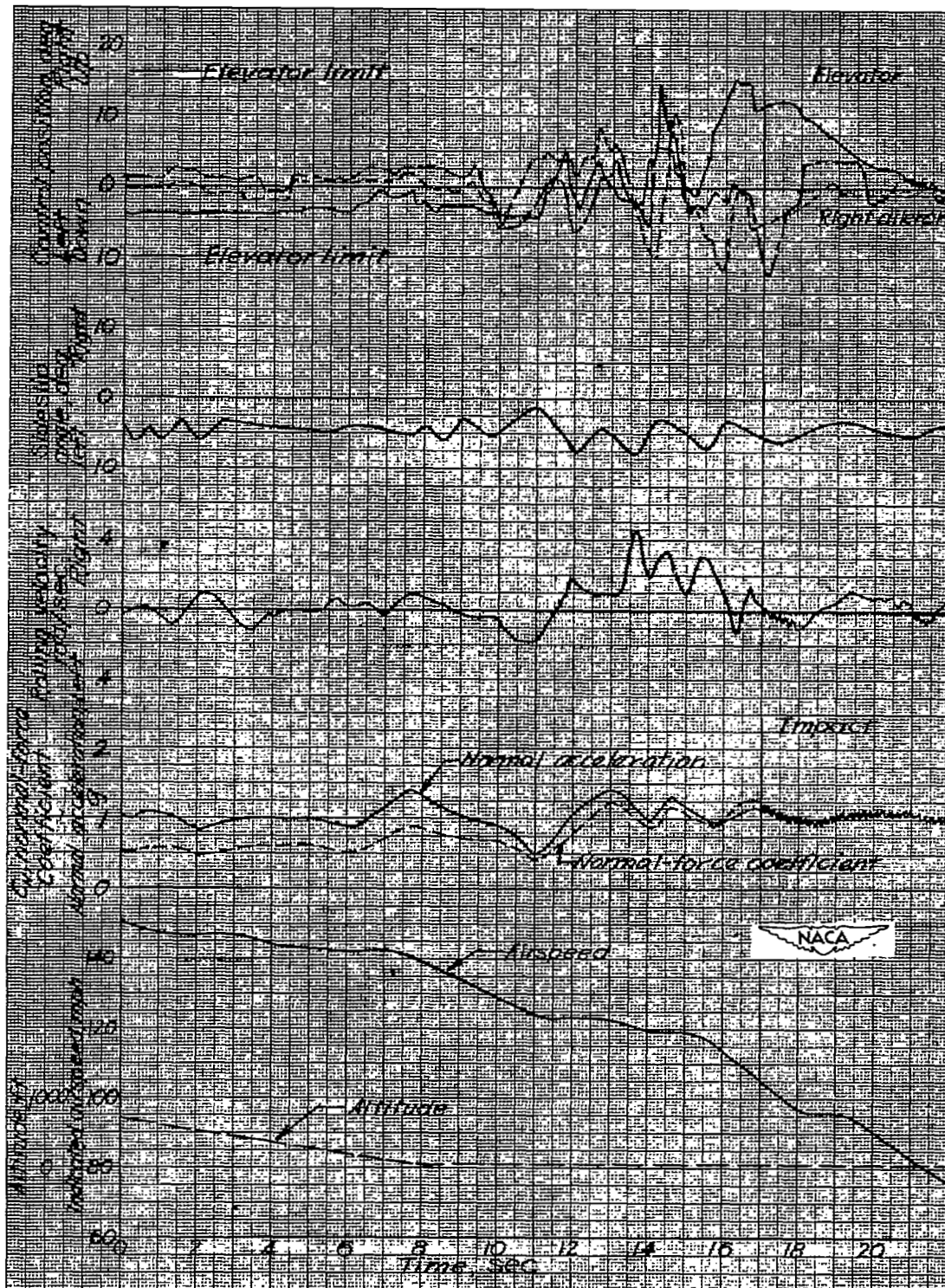

Figure 19.- Time history of a landing, XS-1 airplane with 10-percent-thick wing. Center of gravity, 25 percent M.A.C.  $\frac{W}{S} = 32.5$  lb/sq ft. Stabilizer setting,  $1.1^\circ$ .

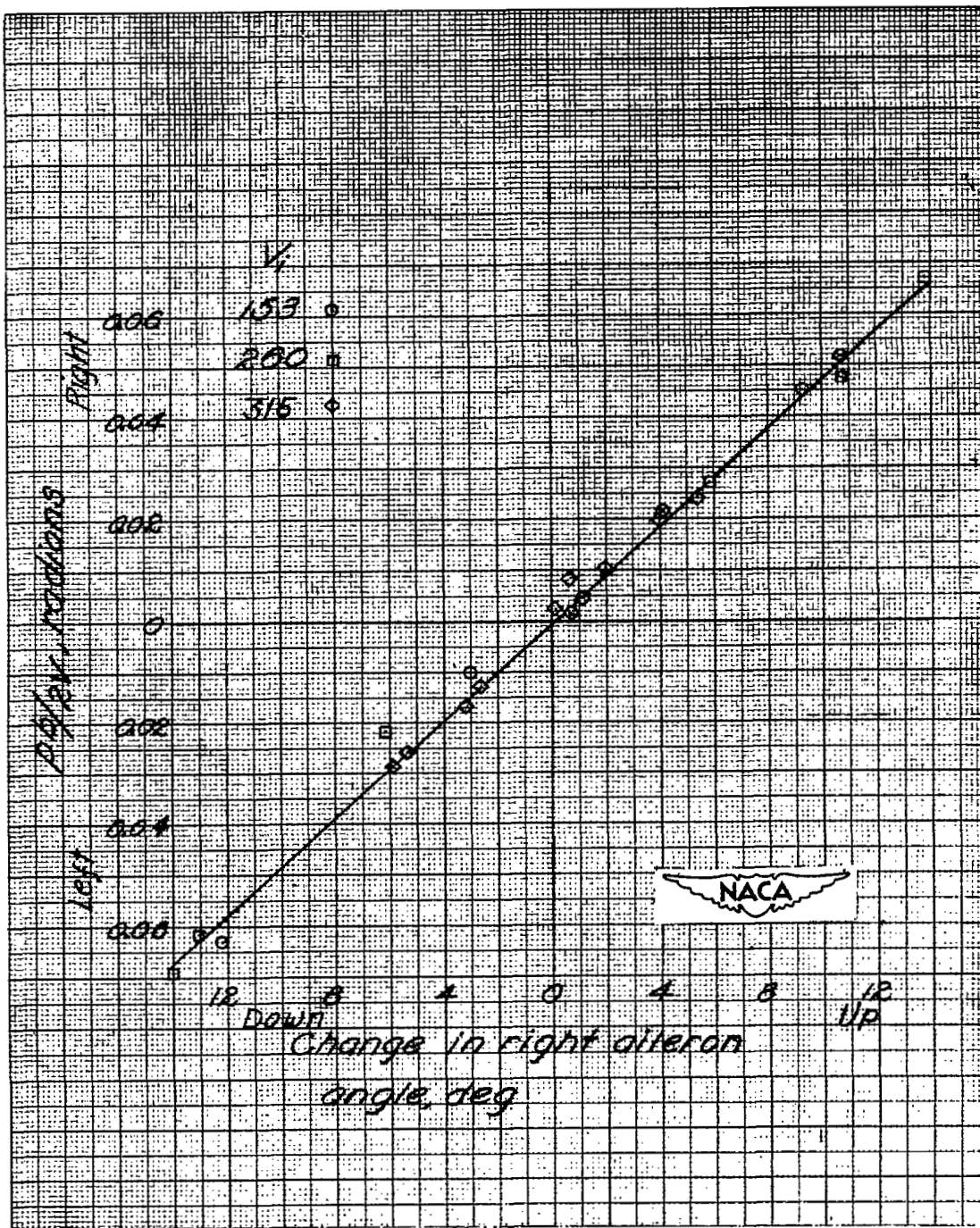

Figure 20.- Variation of helix angle  $\frac{pb}{2V}$  with change in right aileron deflection as measured in clean condition, rudder-fixed aileron rolls. XS-1 10-percent-thick-wing airplane.

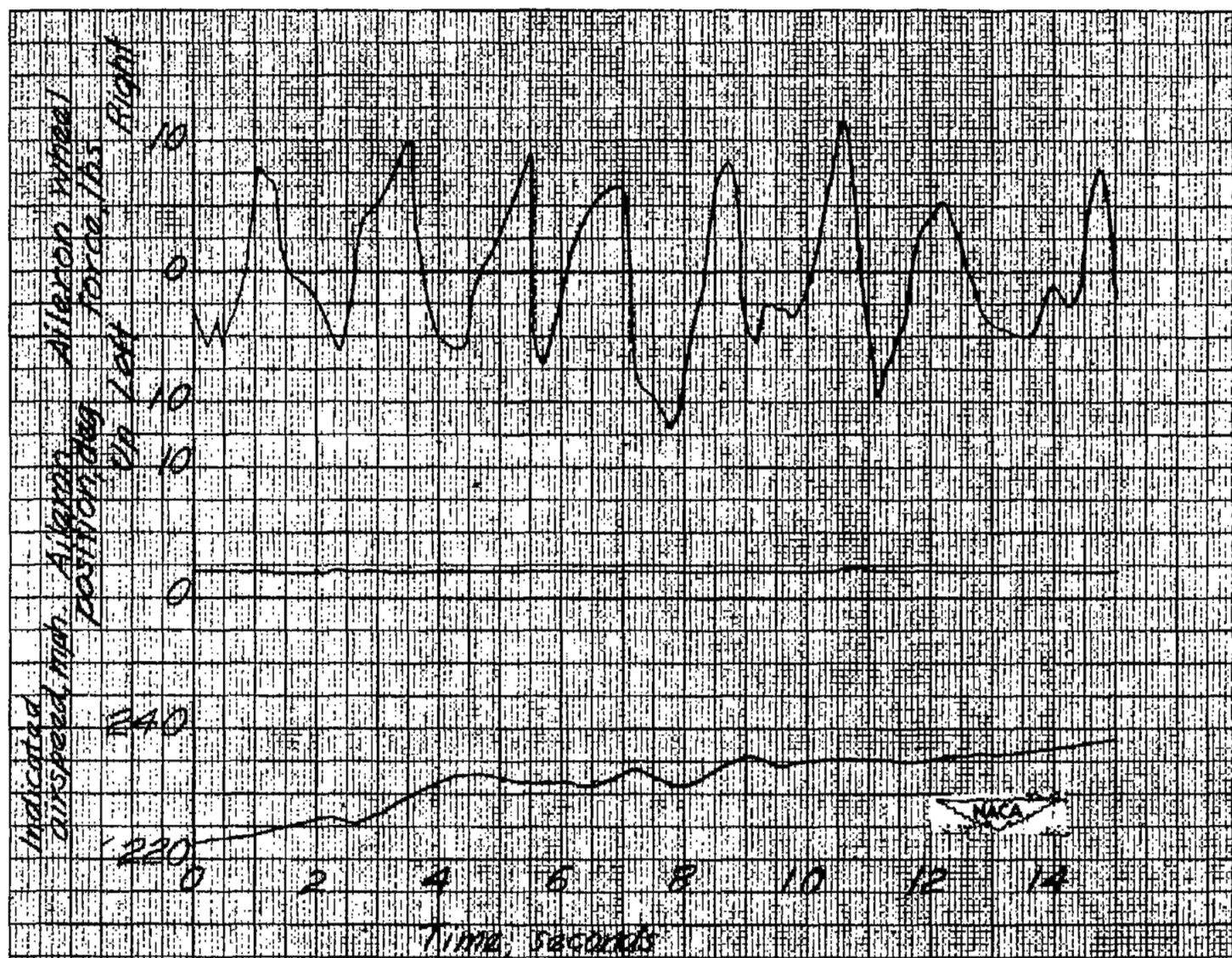
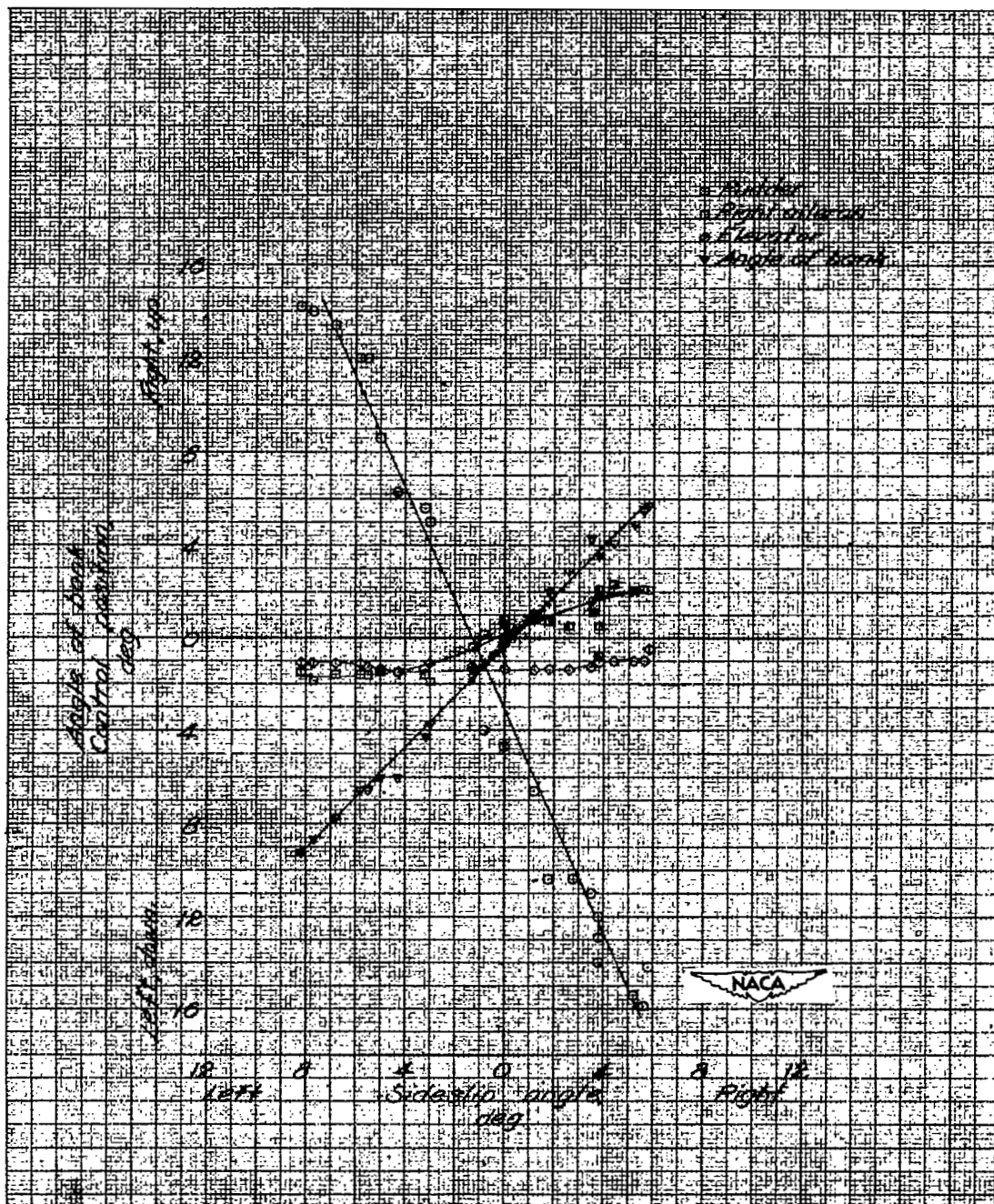

Figure 21.- Typical time history showing aileron force and position during steady flight.  
XS-1 airplane with 10-percent-thick wing.





(a)  $V_1 = 130$  mph.

Figure 22.— Steady sideslip characteristics, XS-1 airplane with 10-percent-thick wing. Gliding flight; flaps and gear down.

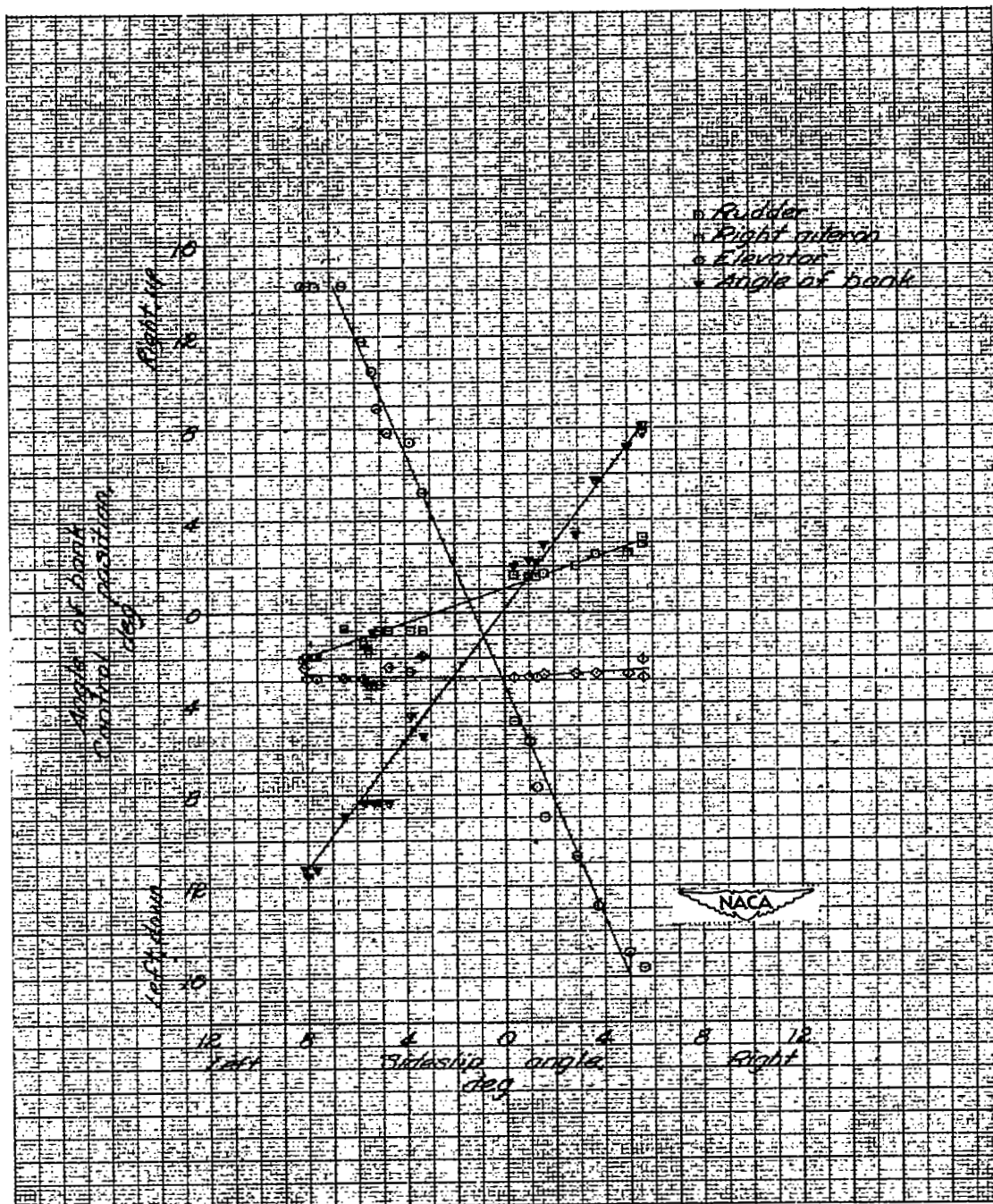

(b)  $V_1 = 150$  mph.

Figure 22.- Continued.

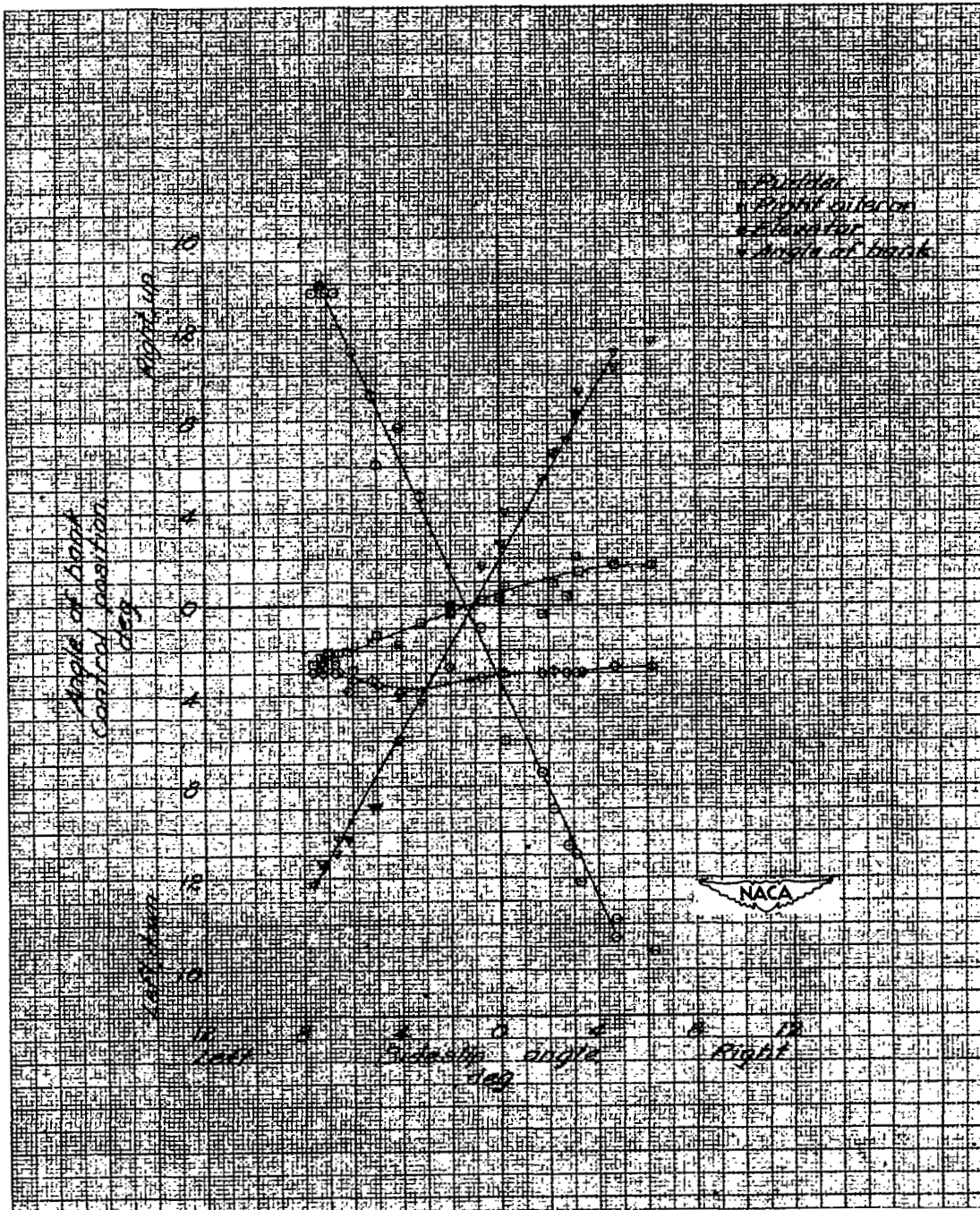

(c)  $V_1 = 172$  mph.

Figure 22.- Concluded.



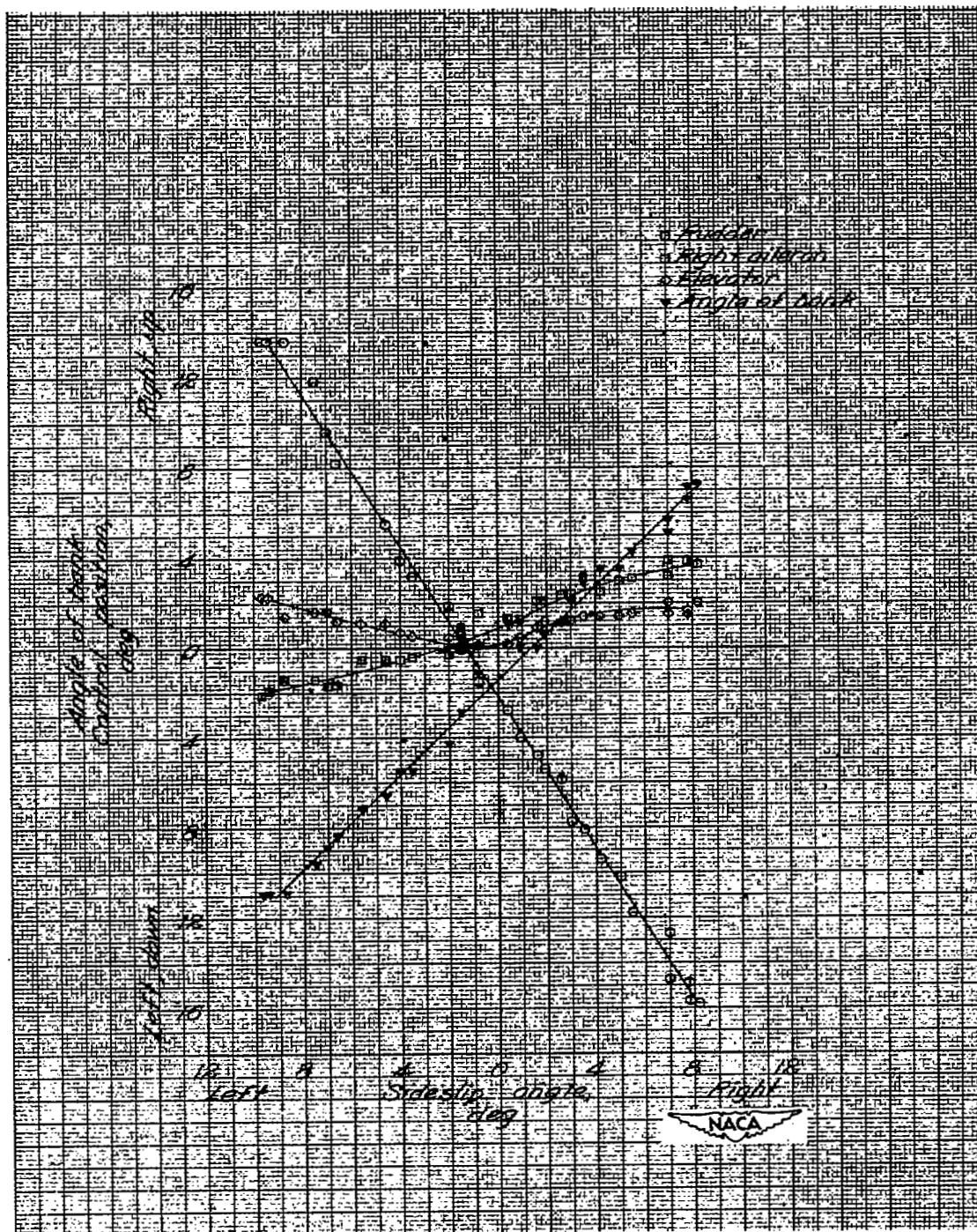

(a) Gliding flight,  $V_1 = 150$  mph.

Figure 23.—Steady sideslip characteristics, XS-1 airplane with 10-percent-thick wing. Flaps and gear up.

(b) Gliding flight,  $V_1 = 247$  mph.

Figure 23.- Continued.



(c) Power on;  $V_1 = 400$  mph;  $M = 0.72$ .

Figure 23.- Concluded.

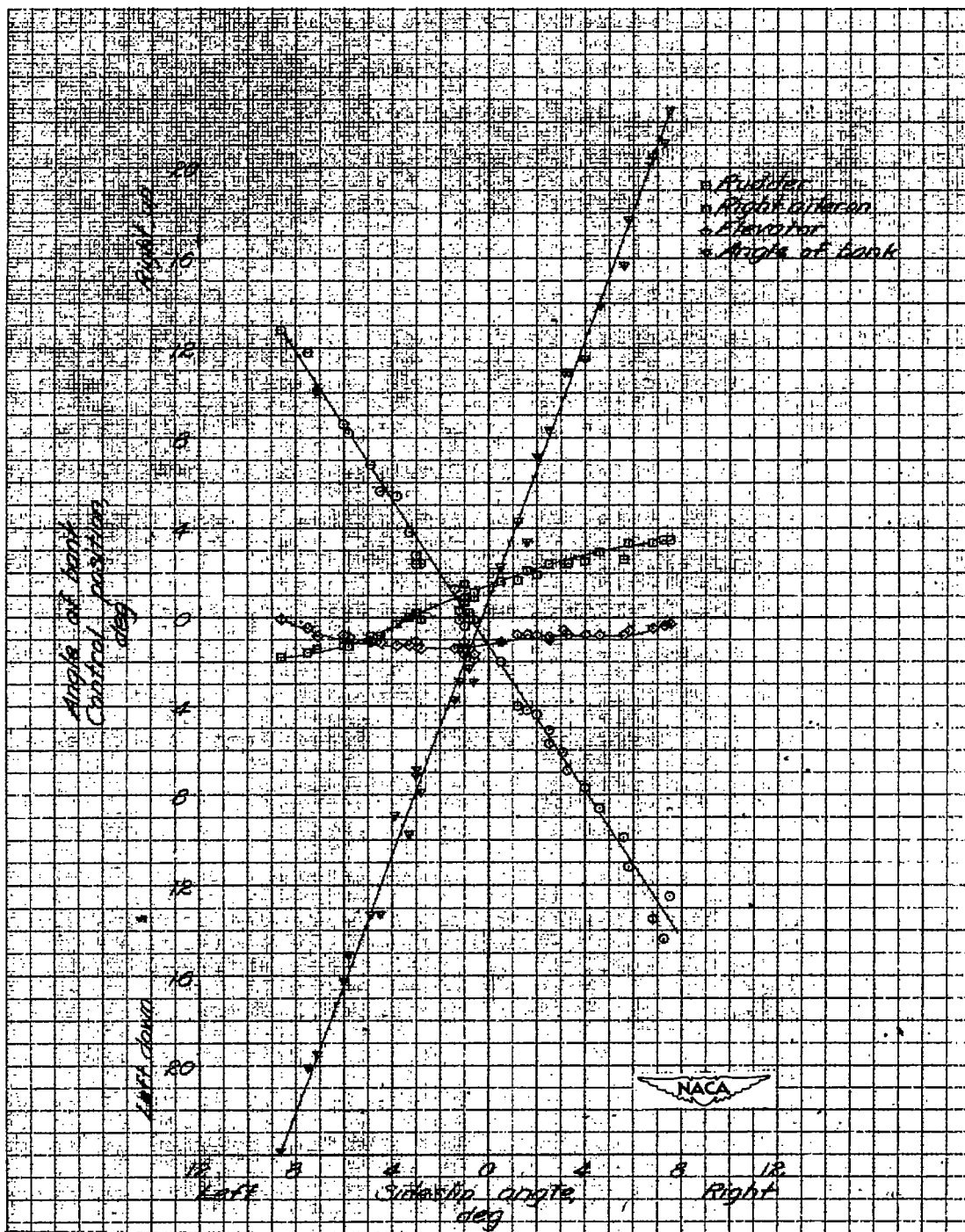
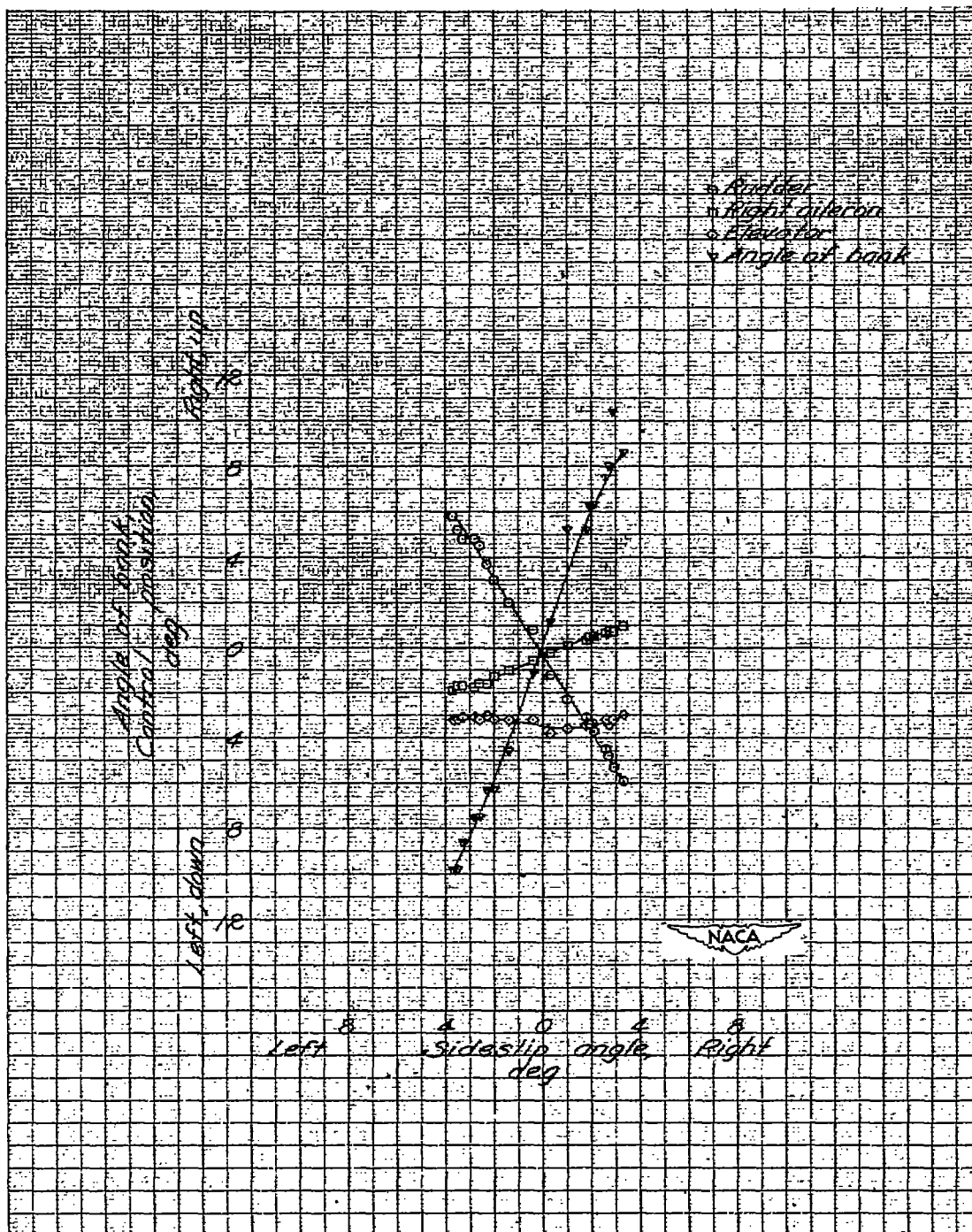
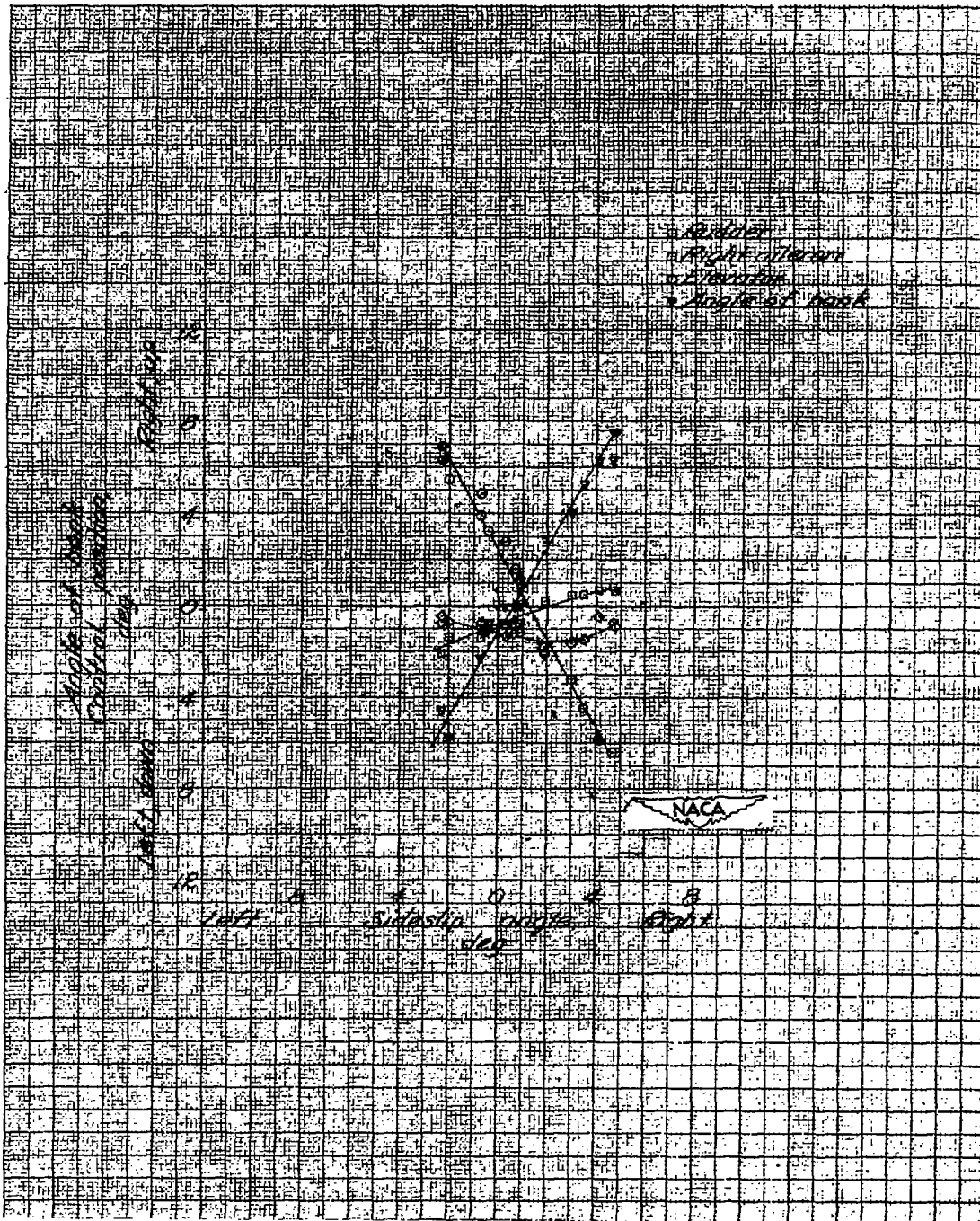

Figure 24.- Steady sideslip characteristics, XS-1 airplane with 8-percent-thick wing. Power on; flaps and gear up;  $V_1 = 295$  mph;  $M = 0.77$ .

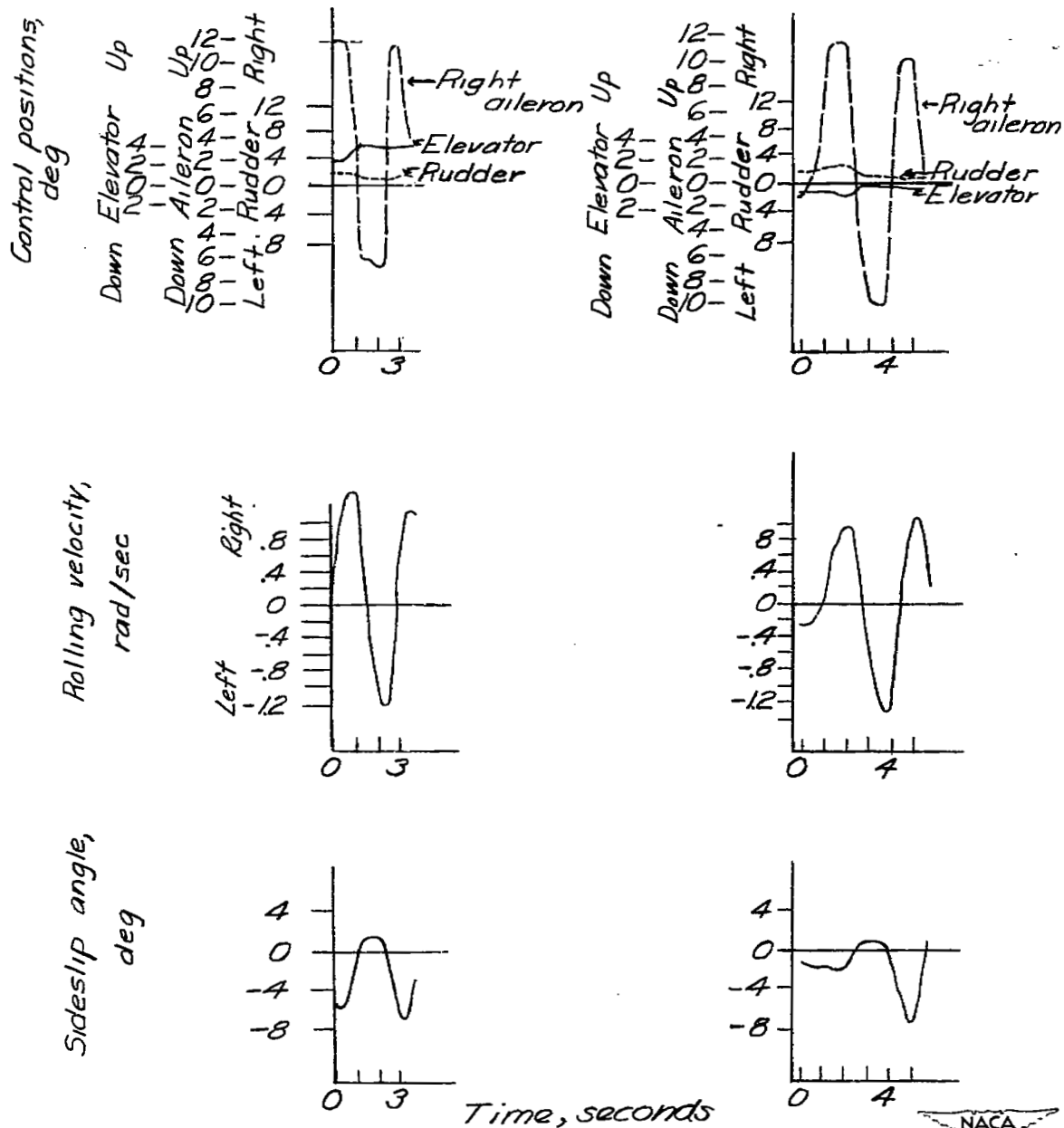

Figure 25.- Time histories of abrupt aileron rolls at 150 mph with rudder held fixed. XS-1 airplane.





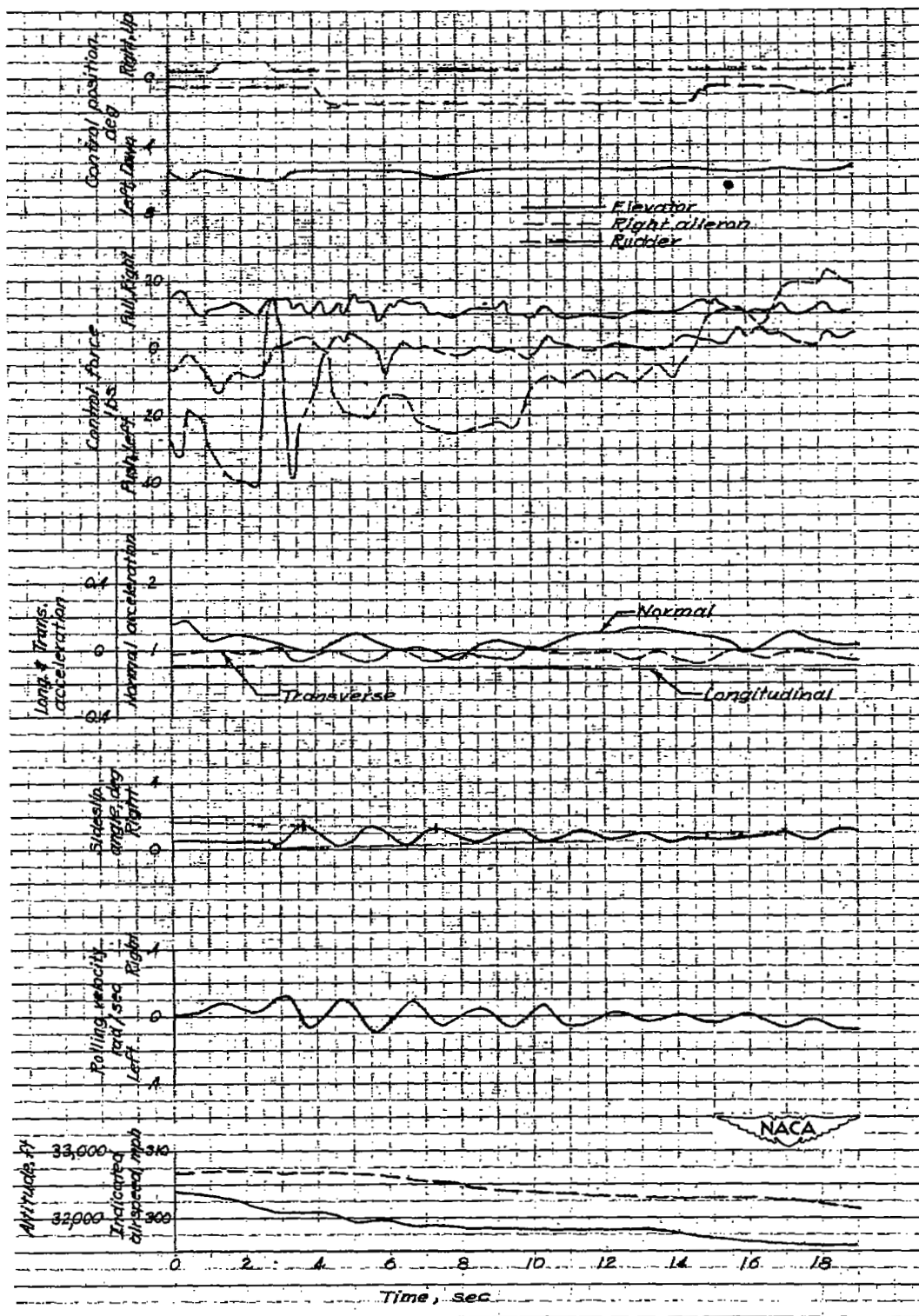

Figure 27.- Time history of a stick-fixed inadvertent lateral oscillation. Gliding flight; relative density factor,  $\mu$  of about 100. XS-1 airplane with 10-percent-thick wing.

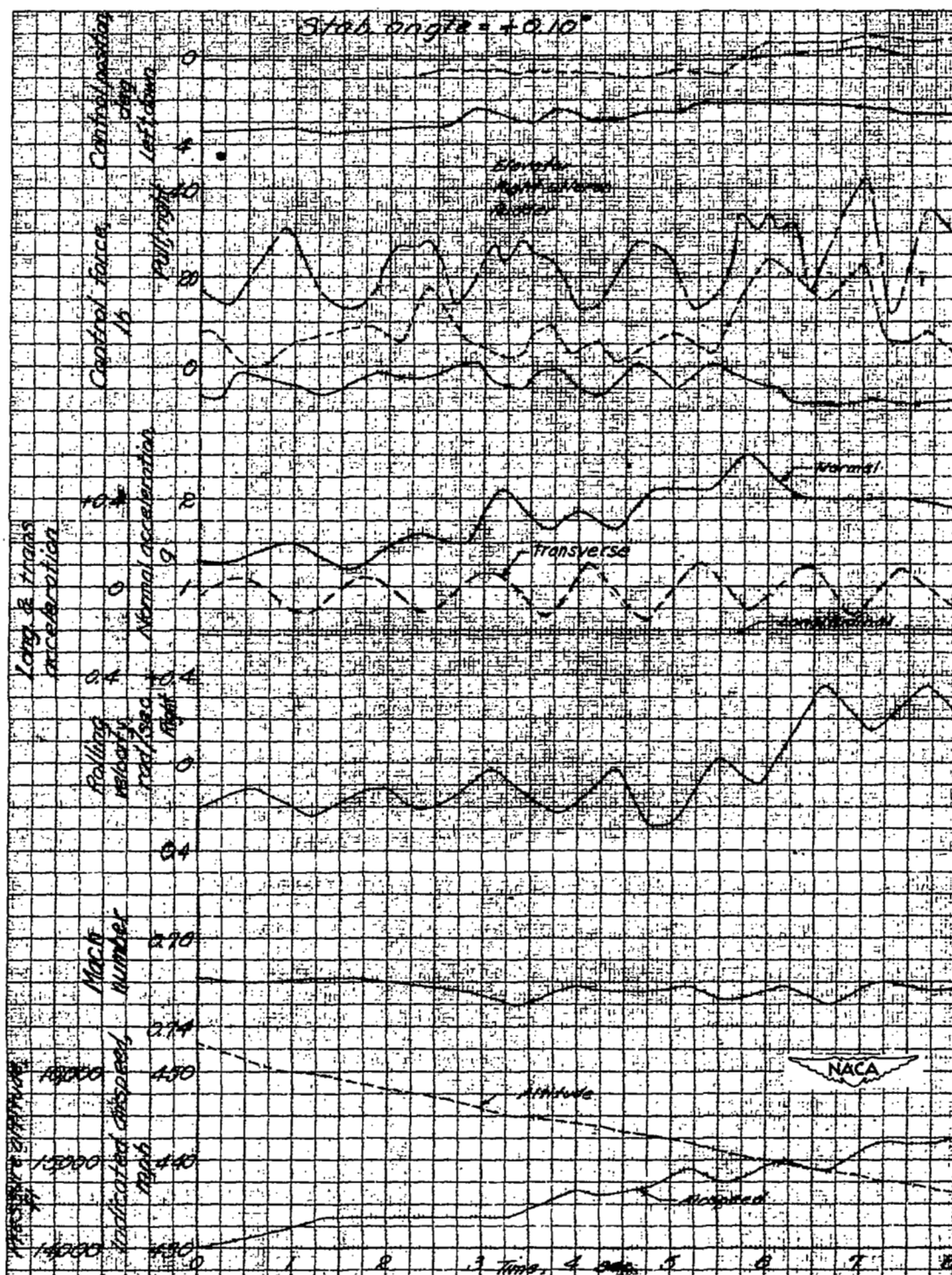

Figure 28.- Time history of an inadvertent lateral oscillation in a power-off turn, rough air. Relative density factor  $\mu$  of about 45. XS-1 airplane with 10-percent-thick wing.

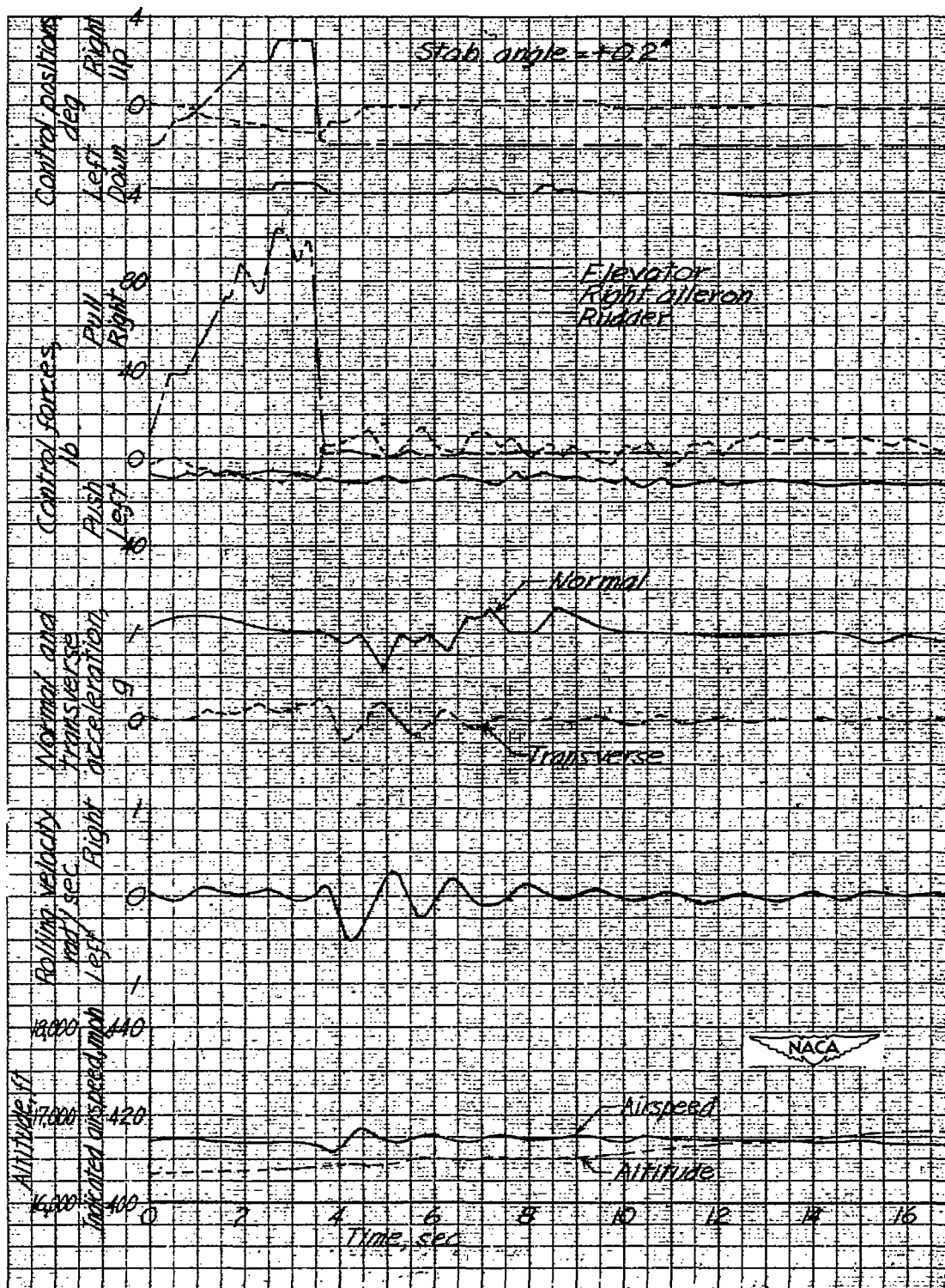
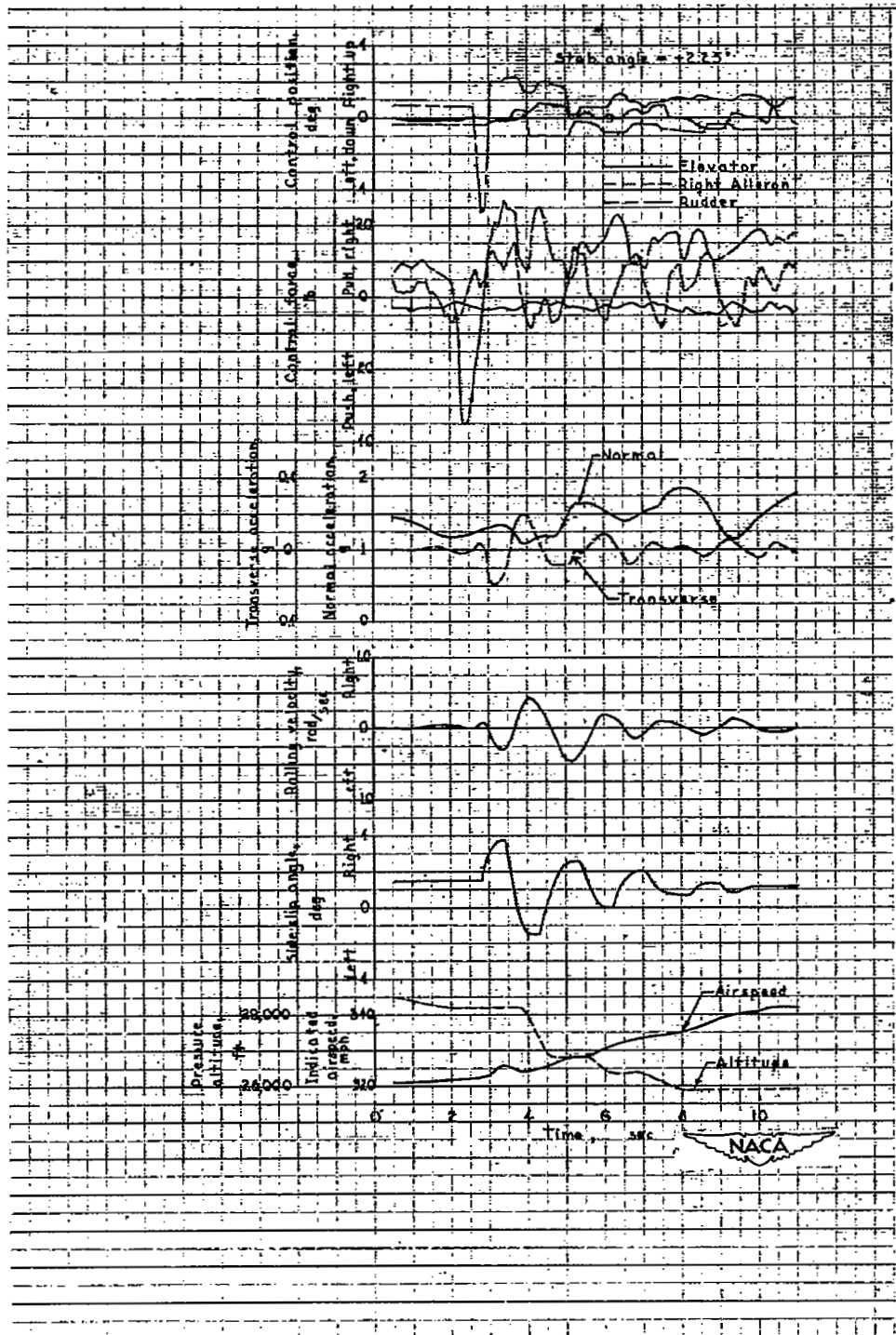

Figure 29.- Time history of abrupt rudder release with power on.  
 $M = 0.73$ ,  $\frac{W}{S} = 72.1$  lb/sq ft. XS-1 airplane with 10-percent-thick wing.



(a) Full Fuel.

Figure 30.—Time histories of abrupt rudder kicks with essentially constant relative density factors and an average Mach number of about 0.740. Various amounts of fuel aboard. XS-1 8-percent-thick-wing airplane.



(b) 40 percent fuel.

Figure 30.- Continued.



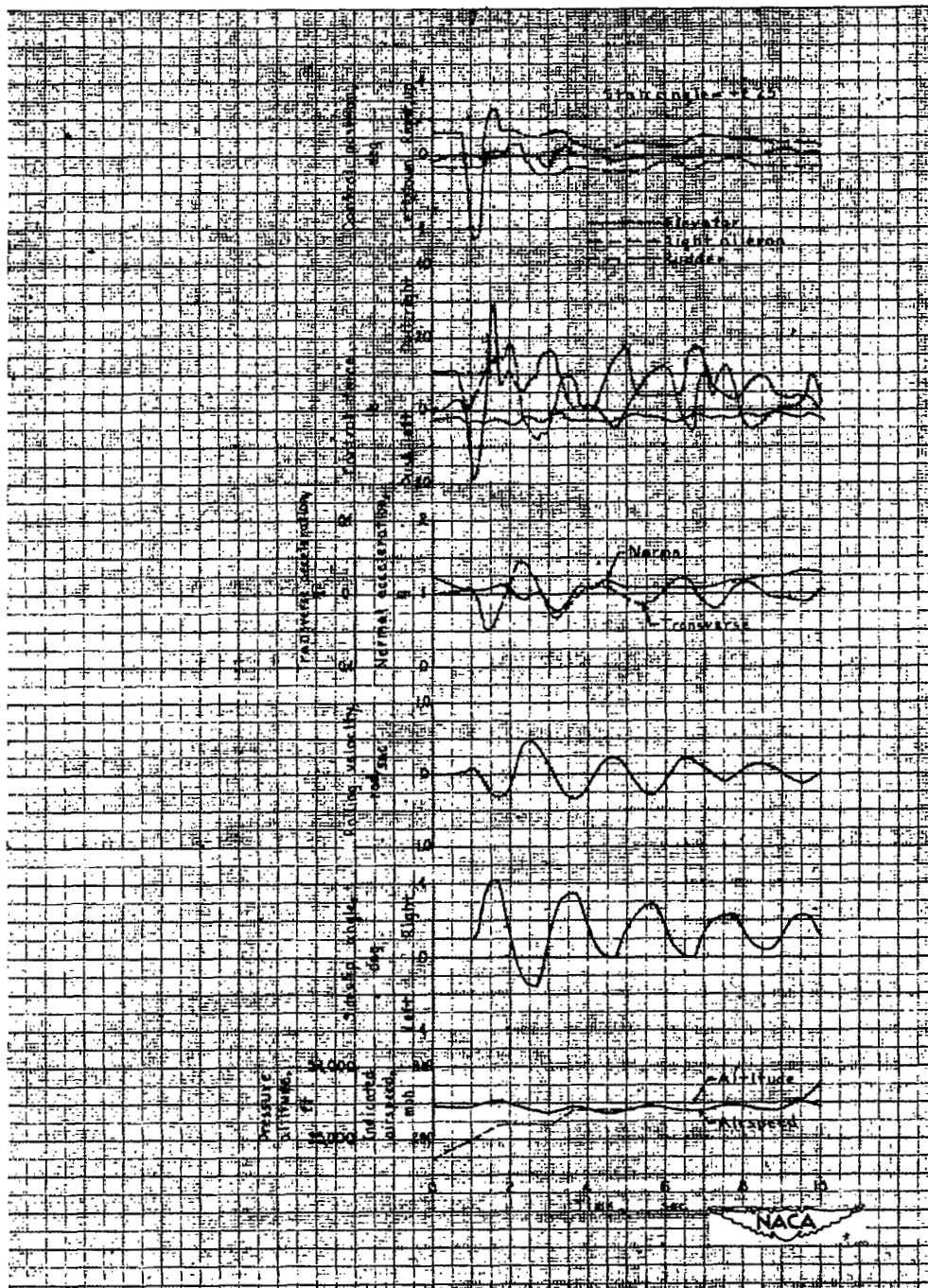

(c) 25 percent fuel.

Figure 30.- Continued.

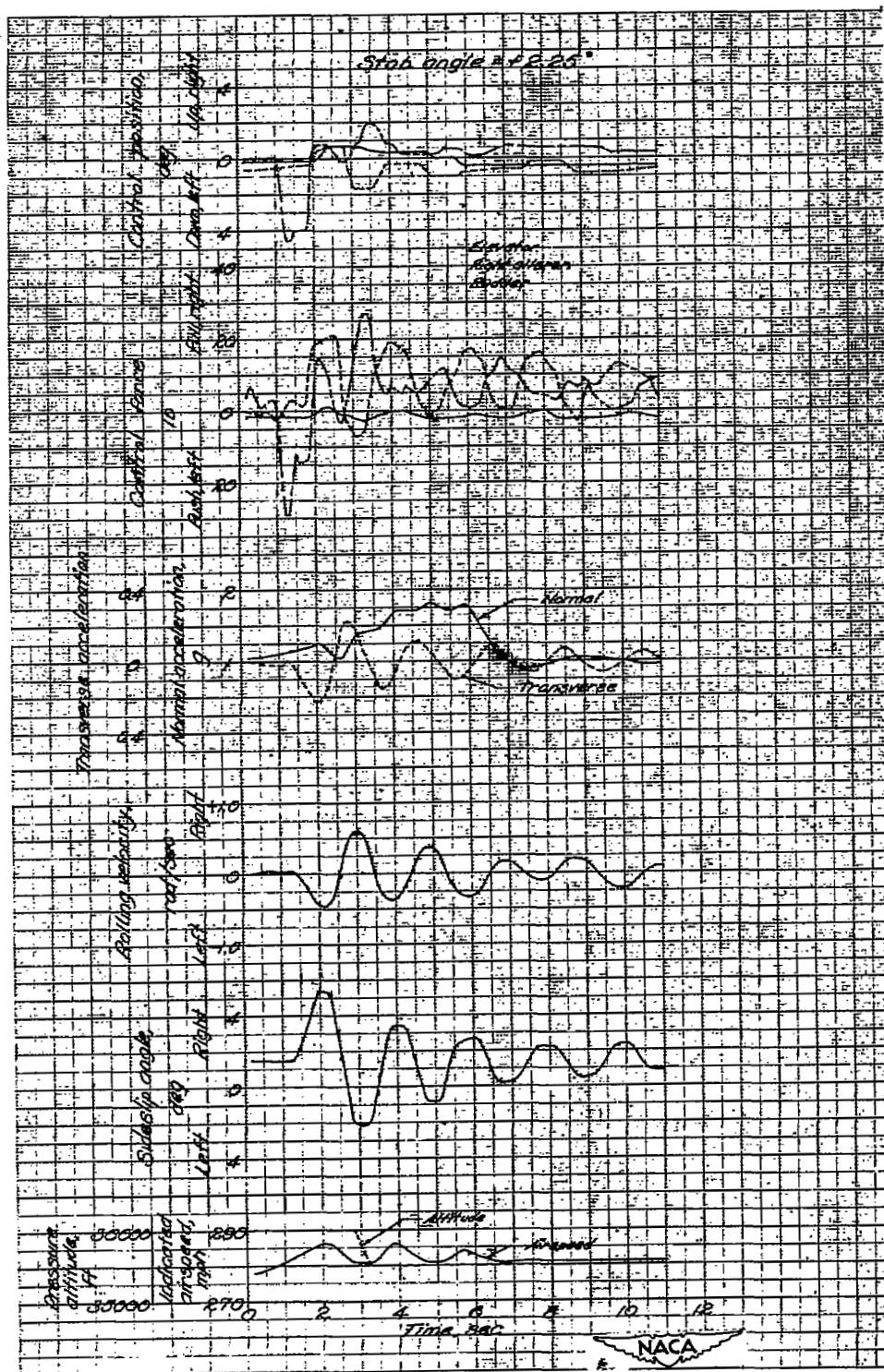

(d) No fuel.

Figure 30.- Continued.



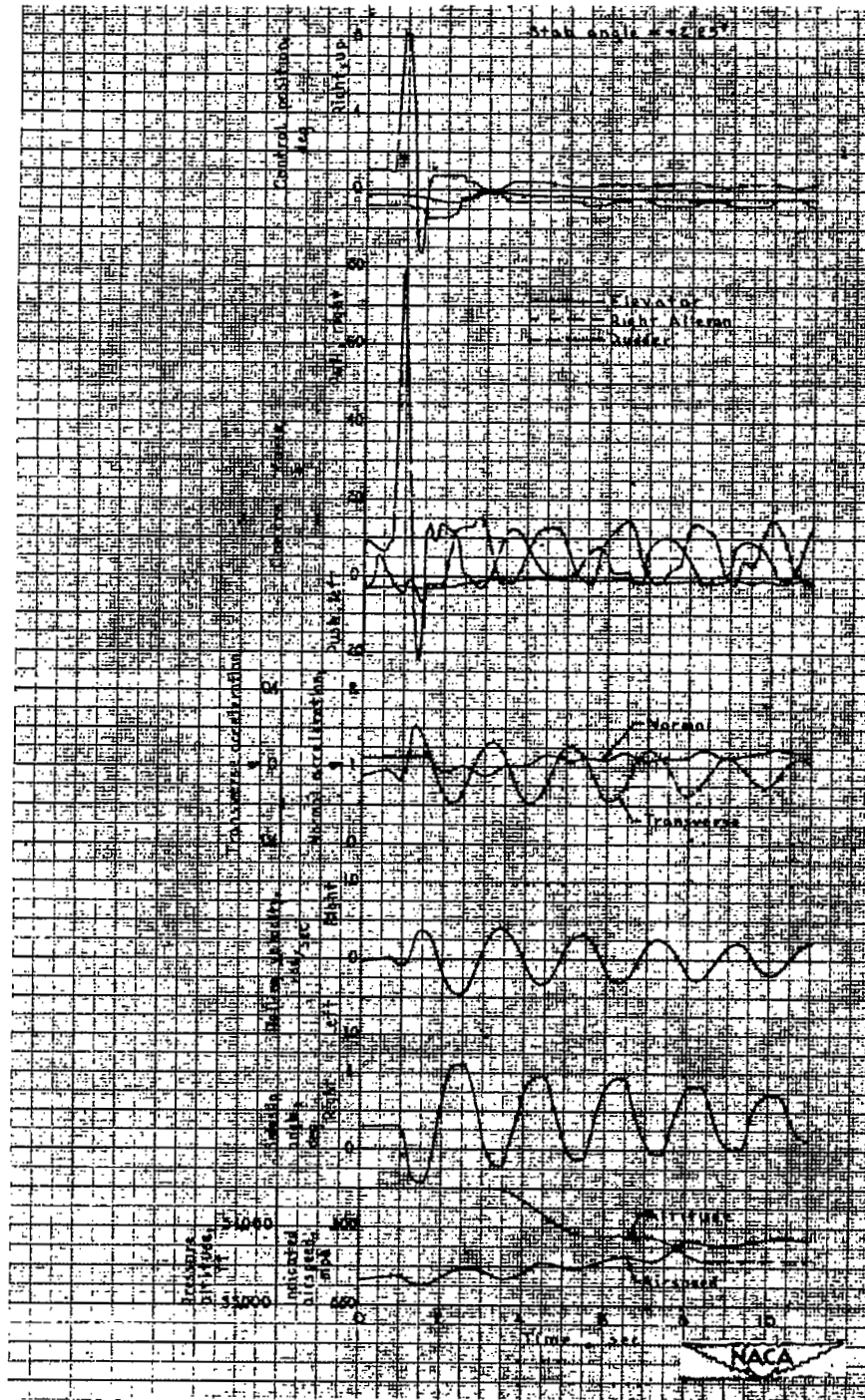

(e) No fuel.

Figure 30.- Concluded.

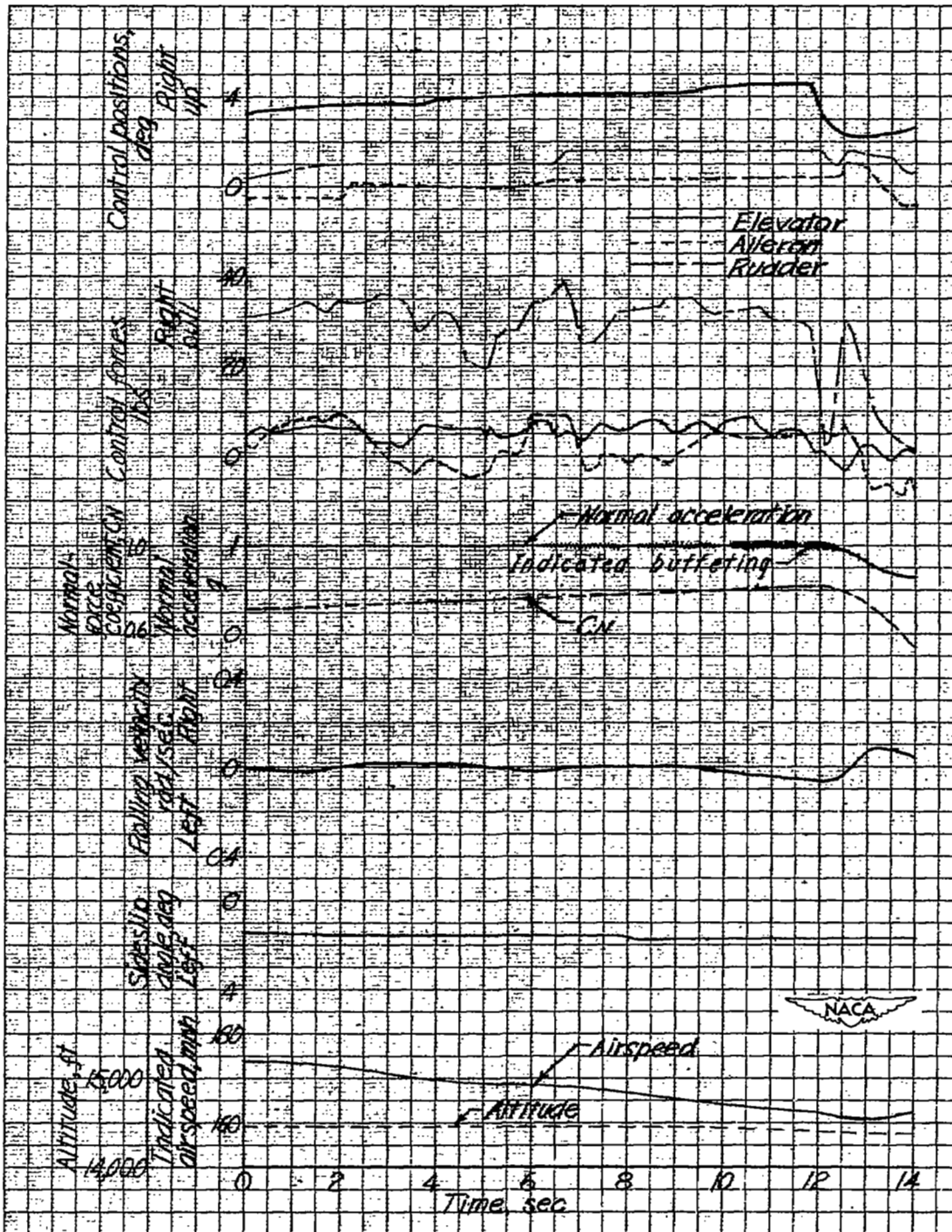

Figure 31.- Time history of a steady stall. XS-1 airplane with 10-percent-thick wing. Gliding flight; flaps and gear up. Center of gravity, 25 percent M.A.C.  $\frac{W}{S} = 56.3$  lb/sq ft. Stabilizer position,  $0.25^\circ$ .

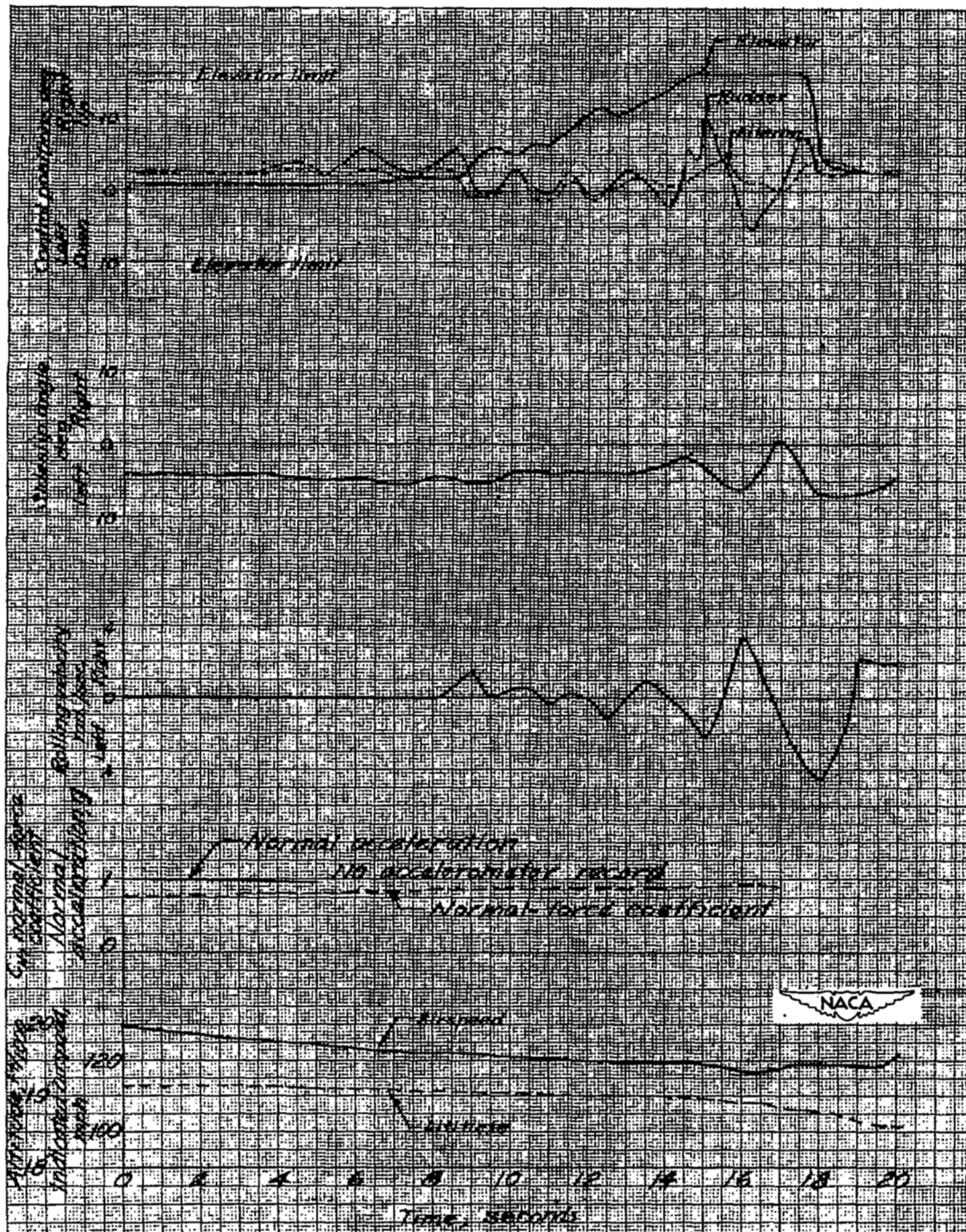

Figure 32.- Time history of a steady stall. XS-1 airplane with 10-percent-thick wing. Gliding flight; flaps and gear up;  $\frac{W}{S} = 32.5$  lb/sq ft. Stabilizer settings,  $1.0^\circ$ .

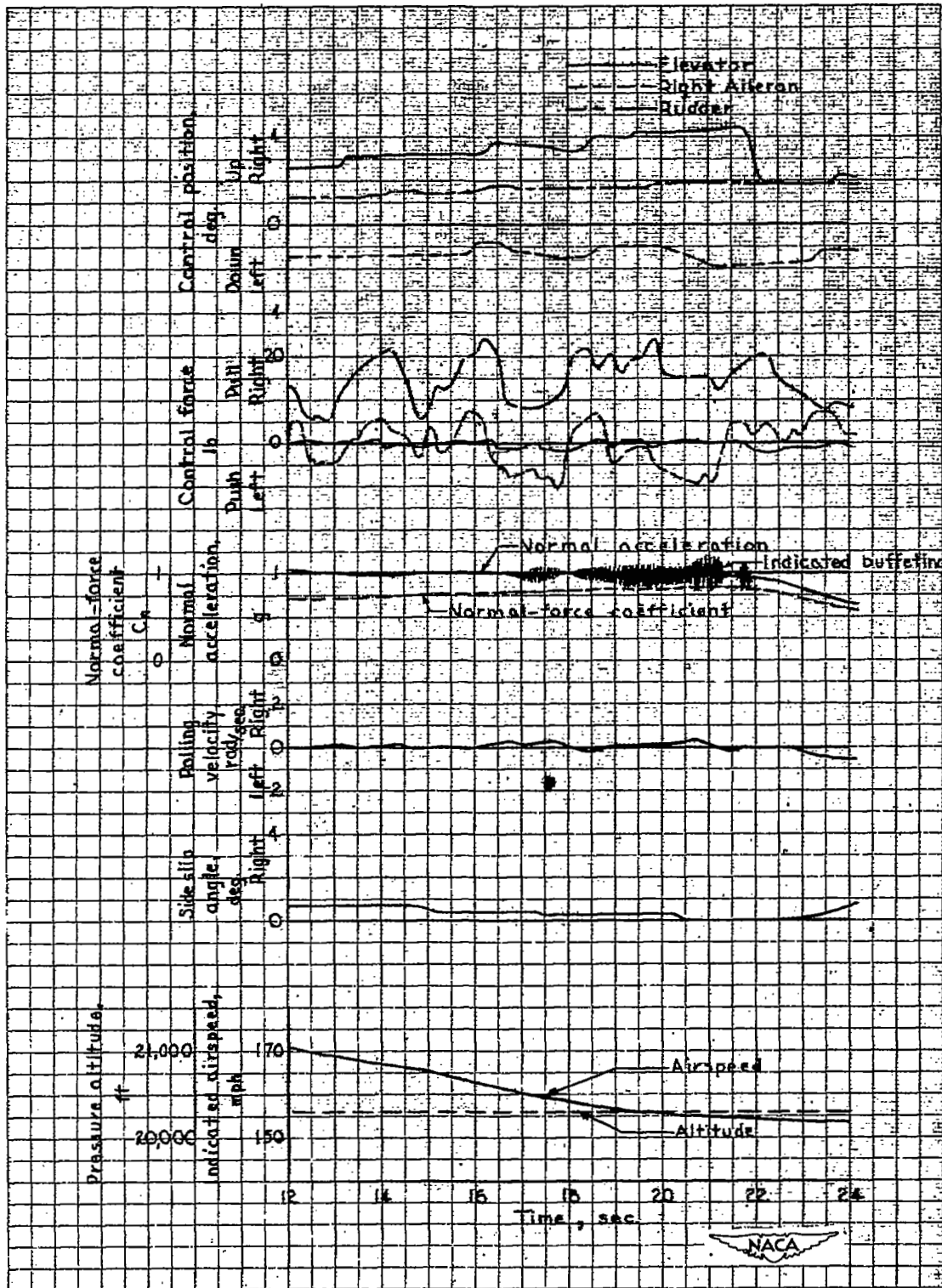

Figure 33.- Time history of a steady stall, XS-1 airplane with 8-percent-thick wing. Gliding flight; flaps and gear up.

$\frac{W}{S} = 53.8$  lb/sq ft. Stabilizer setting,  $2.35^\circ$ .



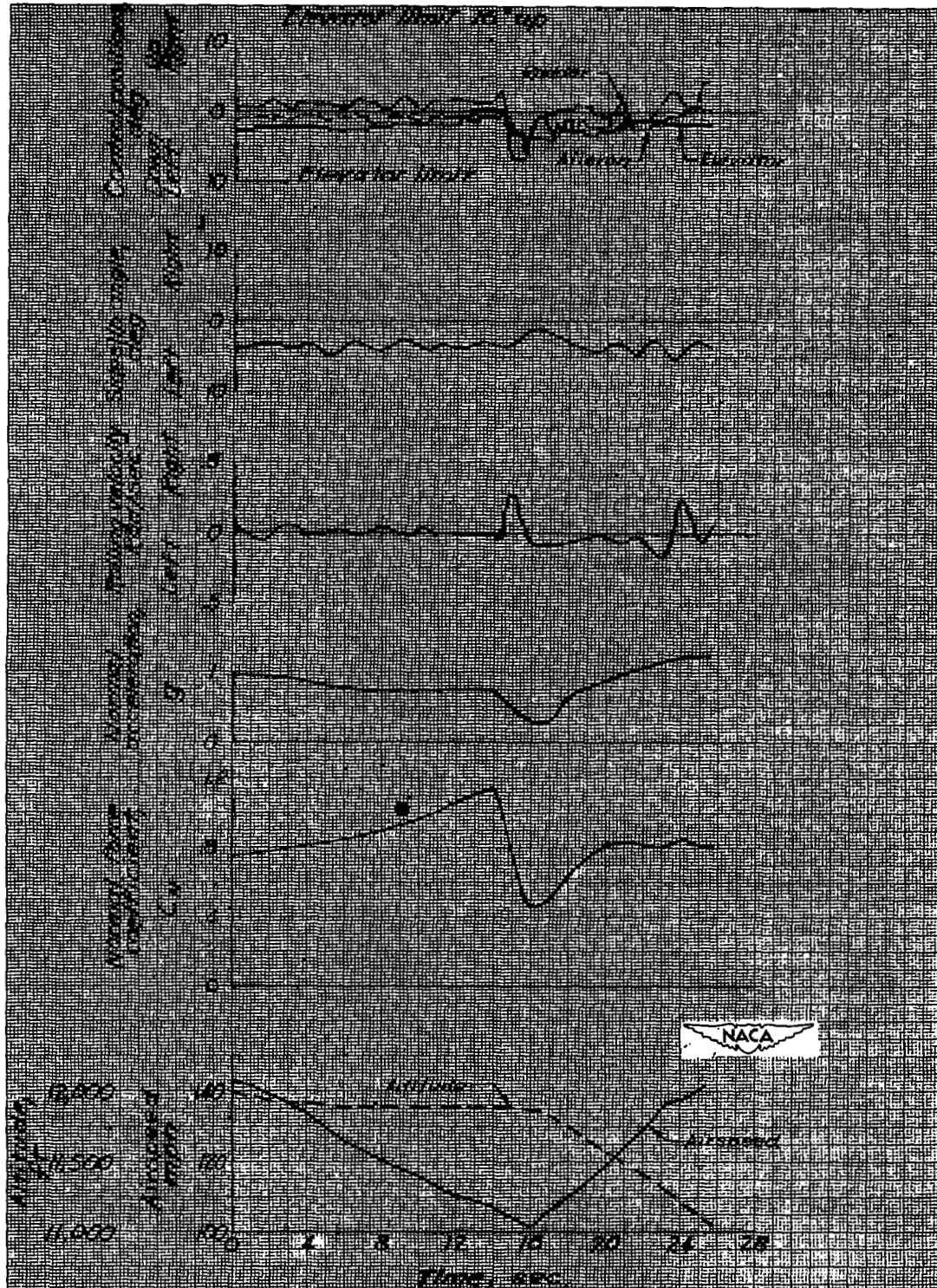

Figure 34.- Time history of a steady stall, XS-1 airplane with 10-percent-thick wing. Gliding flight, flaps and gear down. Center of gravity, 25 percent M.A.C.,  $\frac{W}{S} = 32.5$  lb/sq ft. Stabilizer setting,  $1.0^\circ$ .

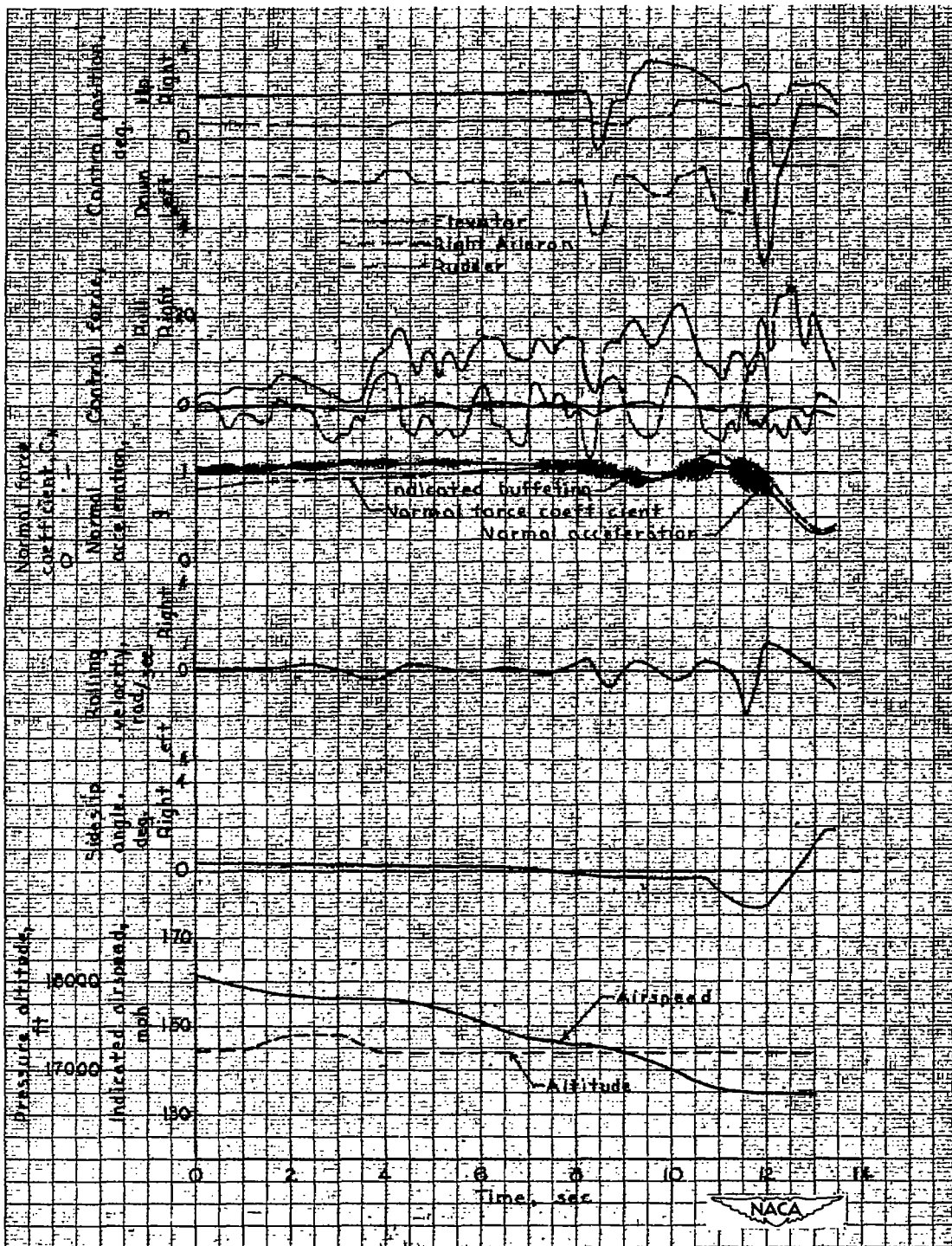

Figure 35.- Time history of a steady stall, XS-1 airplane with 8-percent-thick wing. Gliding flight, flaps and gear down. Center of gravity, 25.0 percent M.A.C.  $\frac{W}{S} = 53.8$  lb/sq ft. Stabilizer position,  $2.35^\circ$ .

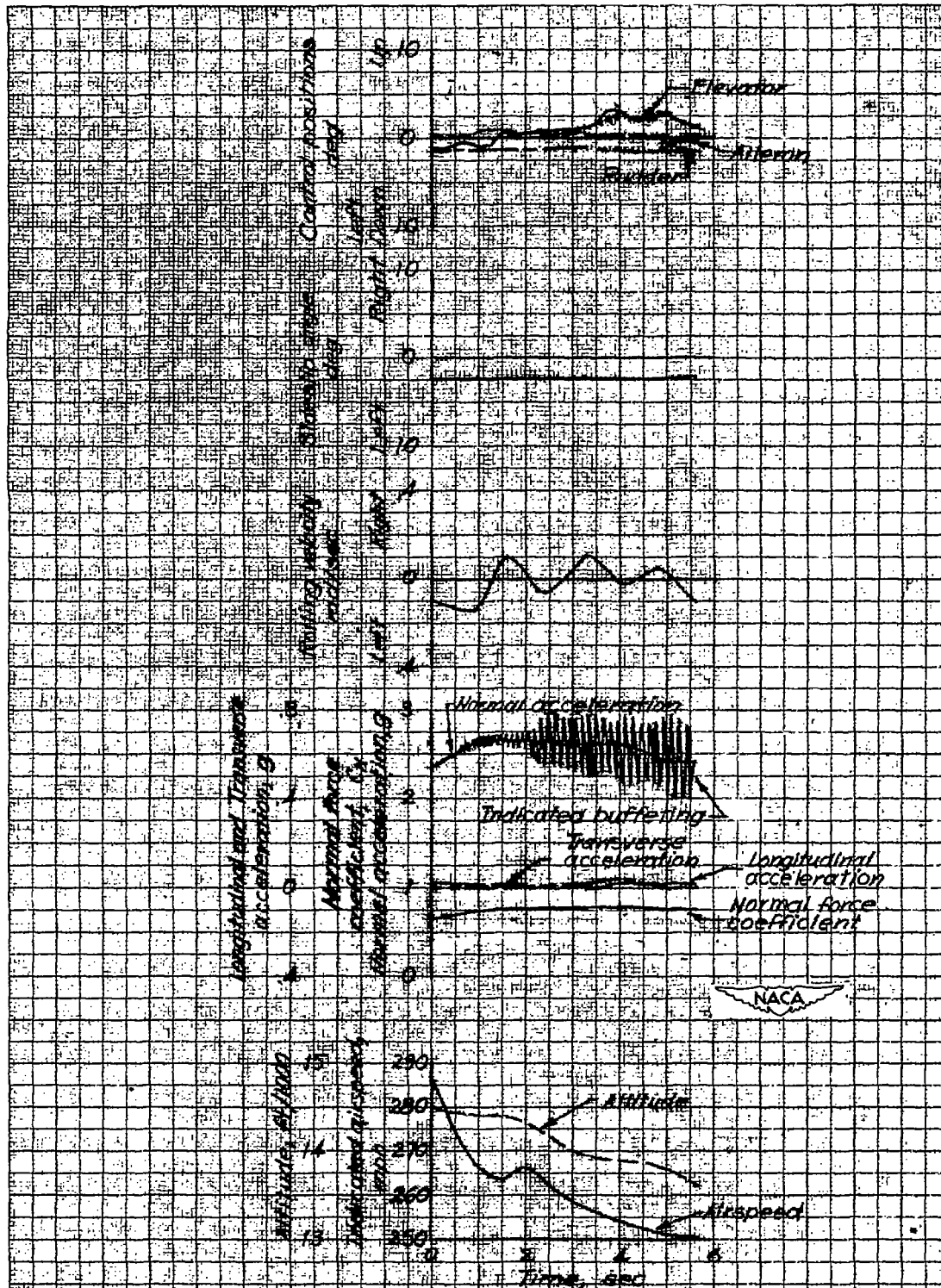
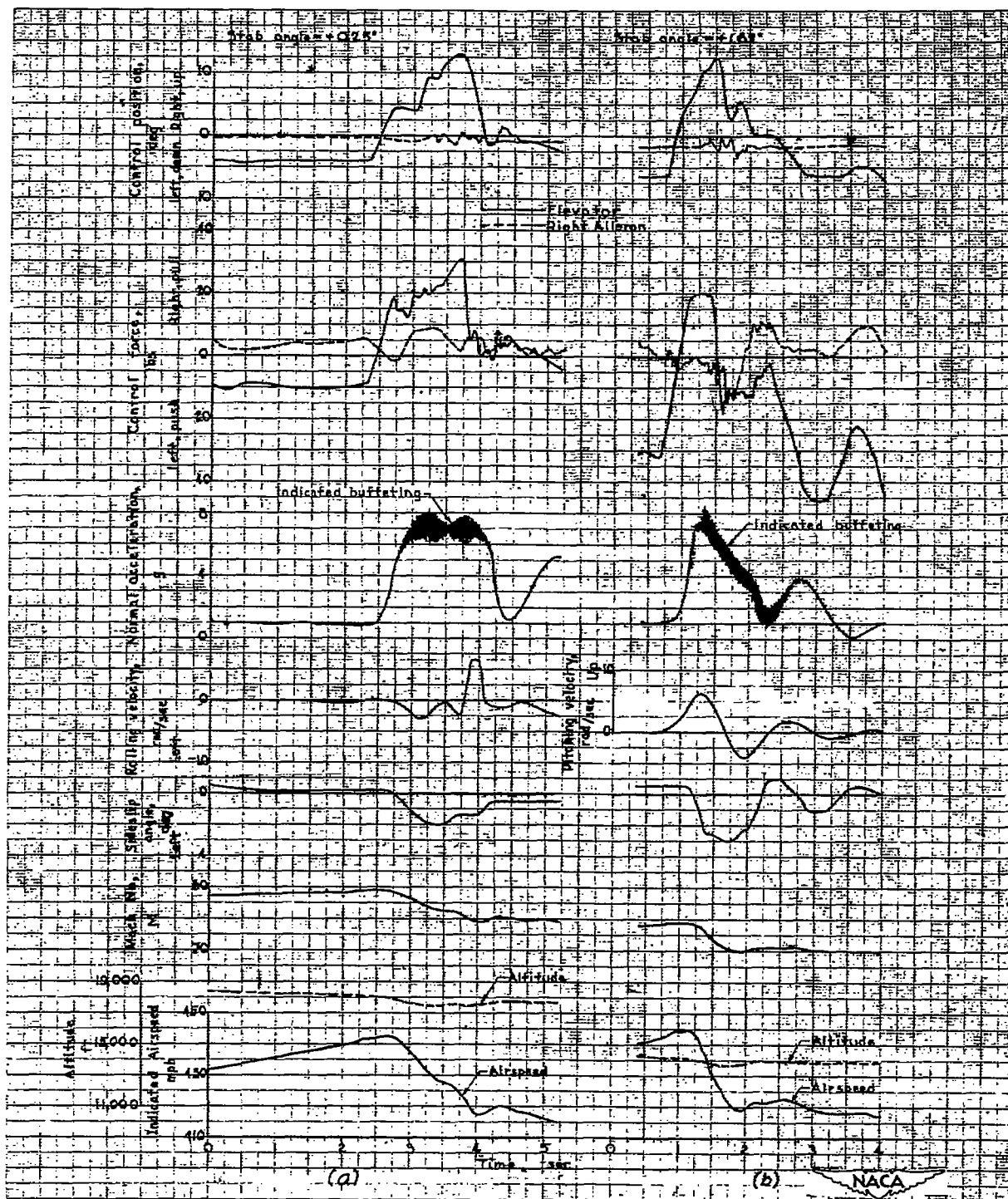

Figure 36.- Time history of a stalled turn. XS-1 airplane with 10-percent-thick wing. Center of gravity, 25 percent M.A.C.  $\frac{W}{S} = 51.9$  lb/sq ft.



(a) XS-1 airplane with 10-percent-thick wing. Center of gravity, 25.3 percent M.A.C.

$$\frac{W}{S} = 51.9 \text{ lb/sq ft.}$$

(b) XS-1 airplane with 8-percent-thick wing. Center of gravity, 25 percent M.A.C.

$$\frac{W}{S} = 53.8 \text{ lb/sq ft.}$$

Figure 37.- Time histories of power-off abrupt pull-ups.



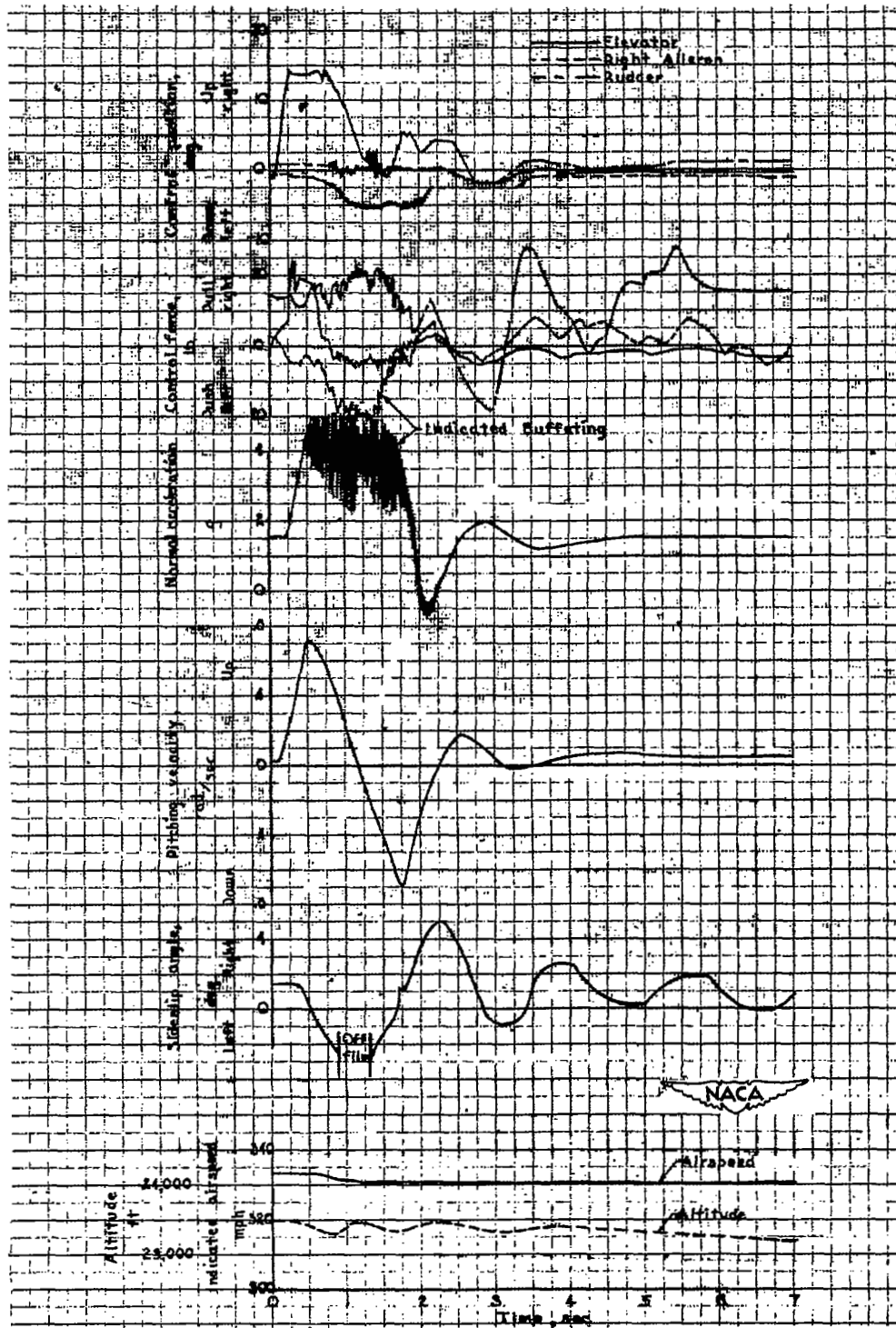

Figure 38.- Time history of an abrupt pull-up followed by a snap roll. XS-1 airplane with 8-percent-thick wing. Center of gravity, 25.0 percent M.A.C.  $\frac{W}{S} = 53.8$  lb/sq ft. Stabilizer position,  $2^\circ$ .