

DEPARTMENT OF THE INTERIOR

TEI-440

GEOLOGIC INVESTIGATIONS OF
RADIOACTIVE DEPOSITS

Semiannual Progress Report, December 1,
1953 to May 31, 1954

This report is preliminary and has not been edited or
reviewed for conformity with U. S. Geological Survey
standards and nomenclature.

June 1954

United States Geological Survey
Washington, D. C.

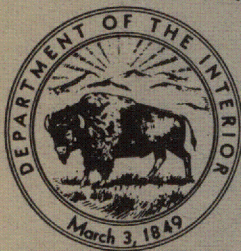

OFFICE COPY
DO NOT REMOVE
U. S. Geological Survey
EW - Albuquerque

UNITED STATES ATOMIC ENERGY COMMISSION
Technical Information Service, Oak Ridge, Tennessee

Subject Category, GEOLOGY AND MINERALOGY.

This report concerns work done on behalf of the Divisions of Raw Materials and Research of the U. S. Atomic Energy Commission.

Issuance of this document does not constitute authority for declassification of classified material of the same or similar content and title by the same author.

This report has been reproduced with minimum alteration directly from manuscript provided the Technical Information Service in an effort to expedite availability of the information contained herein.

Reproduction of this information is encouraged by the United States Atomic Energy Commission. Arrangements for your republication of this document in whole or in part should be made with the author and the organization he represents.

Printed in USA, Price \$1.75 cents. Available from the Office of Technical Services, Department of Commerce, Washington 25, D. C.

TEI-440

GEOLOGIC INVESTIGATIONS OF RADIOACTIVE DEPOSITS

Semiannual Progress Report,
December 1, 1953 to May 31, 1954

June 1954



CONTENTS

	<u>Page no.</u>
Introduction	15
Summary	16
Uranium in sandstone-type deposits	22
Colorado Plateau geologic studies	22
Regional geologic mapping	22
Carrizo Mountains area, Ariz.-N. Mex., quadrangle mapping project, by J. D. Strobell, Jr.	22
Red House Cliffs area, Utah, quadrangle mapping project, by T. E. Mullens	24
White Canyon area, Utah, quadrangle mapping project, by A. F. Trites, Jr.	24
Capitol Reef area, Utah, quadrangle mapping project, by J. F. Smith, Jr.	25
Elk Ridge area, Utah, quadrangle mapping project, by R. Q. Lewis, Sr.	26
San Rafael Swell, Utah, strip mapping project, by R. C. Robeck	27
Comb Ridge, Utah, quadrangle mapping project, by J. D. Sears.	27
Western San Juan Mountains, Colo., by A. L. Bush. .	28
Photogeologic mapping, by W. A. Fischer.	30
Stratigraphic studies, by G. A. Williams	30
Morrison formation.	30
Triassic and associated formations.	33
Ground-water studies, by D. A. Jobin	35
Botanical studies.	37
Botanical research, by H. L. Cannon	37
Botanical prospecting, by P. F. Narten.	38
Resource appraisal	39
Ore distribution study, by C. C. Gilbert.	39
Reconnaissance resource appraisal, by H. S. Johnson	39
Mineralogic studies.	40
General mineralogic studies, by T. Botinelly and A. D. Weeks	40
Distribution of elements, by W. L. Newman	42
Cenozoic studies	45
District geophysical studies, by R. A. Black	45
Regional geophysical studies, by H. R. Joesting.	47
Aeromagnetic surveys.	47
Gravimetric surveys	49
Preliminary analysis of geophysical results	51
Uravan area.	51
Inter-River area	53
Plans	54
Original-state core studies, by G. E. Manger	55

Powder River Basin, Wyoming, by W. N. Sharp, E. D. McKay, and Paul Soister	64
South Dakota	64
Black Hills, by G. B. Gott, R. S. Jones, E. V. Post, and W. A. Braddock.	64
Geologic investigations.	64
Lithology	66
Structure	66
Other phenomena bearing on mineralization	67
Geochemical and geobotanical investigations.	69
New Mexico	72
Guadalupe, by C. M. Tschanz	72
Uranium in limestone.	74
Miller Hill area, Carbon County, Wyo., by J. D. Vine and G. E. Pritchard.	74
Uranium in veins, igneous rocks, and related deposits	75
District studies	75
Colorado Front Range, by P. K. Sims	75
Exploration.	75
Distribution of significant uranium deposits	79
Mineralogy	79
Paragenesis of pitchblende-bearing veins	79
Relation of pitchblende to wall rocks.	84
Relation of metatorbernite to altered wall rocks in the Eureka Gulch area	84
Relation of uranium deposits to vein structure	86
Relation of carbonate-epidote alteration in Tertiary intrusive rocks to uranium mineralization.	86
Origin of uranium minerals	87
Ralston Buttes district, Jefferson County, Colo., by D. M. Sheridan and C. H. Maxwell.	89
Reconnaissance for radioactive materials, San Juan Mountains, Colo., by C. T. Pierson	89
Boulder Batholith, Montana, by G. E. Becraft.	91
Mineralogy and geochemistry, by George Phair and J. C. Antweiler.	93
General geologic studies	95
Zonal relations of uranium deposits in metalliferous districts, by S. R. Wallace and R. H. Campbell.	95
Frequency distribution of uranium with relation to enclosing rock type, by J. W. Adams	96
Relationship of uranium and other trace elements to post-Cretaceous vulcanism, by R. R. Coats	99

Uranium in carbonaceous rocks	100
Coal and lignite	100
Eastern United States, by J. W. Huddle and E. D. Patterson.	100
Southwestern Colorado and northwestern New Mexico, by	
E. H. Baltz, Jr	101
Utah-New Mexico, by H. D. Zeller.	102
North Dakota, by G. W. Moore.	102
Ekalaka lignite field, Carter County, Mont., by J. R. Gill.	109
Mendenhall area, Slim Buttes, Harding County, S. Dak.,	
by J. R. Gill	113
Eastern Red Desert, Sweetwater County, Wyo., by Harold	
Masursky, J. G. Stephens, and R. F. Gantnier.	117
Western Red Desert area, Sweetwater County, Wyo., by	
G. N. Pipiringos.	118
Uranium in lignite and coal, by I. A. Breger and M. Deul.	121
Uraniferous coals.	121
Organo-uranium associations in the Colorado	
Plateau region	123
Coal petrography, by J. M. Schopf, R. J. Gray,	
C. J. Felix, and J. C. Warman	124
Core processing, by J. M. Schopf, J. C. Warman,	
R. J. Gray, and C. J. Felix	129
Black shales	129
Eastern states, by J. R. Pepper	129
Texas, by D. H. Eargle.	132
Northern Rocky Mountain region, by W. J. Mapel	136
Goose Creek district, Idaho, by W. J. Mapel and	
W. J. Hail, Jr.	139
Chattanooga shale, by L. C. Conant.	139
Uranium in black shales, by M. Deul and I. A. Breger.	141
Asphaltite and petroleum	142
Asphaltic rocks in the western states, by W. J. Hail, Jr.	142
Uranium in asphaltite and petroleum, by A. T. Myers	143
Uranium in phosphates	146
Northwest phosphate, by V. E. McKelvey	146
Sections of the Phosphoria formation measured in 1953,	
by L. D. Carswell, R. W. Swanson, R. P. Sheldon, and	
T. M. Cheney.	146
Interpretation of data on the uranium content of the	
Phosphoria formation, by E. R. Cressman and	
L. D. Carswell.	146
Selenium in the phosphatic members of the Phosphoria	
formation, by R. A. Gulbrandsen	147
Southeast phosphate.	148
Exploration, by W. L. Emerick	148
Company drilling	148

Geologic drilling	149
Mobile drilling	149
Radiometric logging of drill holes	149
Economic geology, land-pebble phosphate field, by J. B. Cathcart	149
Geology of the north and east edges of the land-pebble phosphate district, by K. B. Ketner and L. J. McGreevy	150
Stratigraphy of middle Tertiary rocks in part of west- central Florida, by W. J. Carr and D. C. Alverson	152
Field work	152
Laboratory and office work	155
Stratigraphy of parts of Hardee and DeSoto Counties, Florida, by M. H. Bergendahl	156
Occurrence of uranium in phosphate deposits, by Z. S. Altschuler, R. S. Clarke, Jr., and E. J. Young	157
Geochemistry	157
Petrology	159
Field studies	159
Uranium in placer deposits	161
Southeastern monazite exploration, by W. C. Overstreet	161
Central Idaho placers, by J. H. Mackin and D. S. Schmidt	162
Wet Mountains, Colo., by R. A. Christman, M. R. Brock, and Q. D. Singewald	163
Reconnaissance for uranium in the United States	166
Northeast district, by F. A. McKeown	166
Phillips mine area, Putman and Westchester Counties, N.Y.	166
Marlinton, Pocahontas County, Va.	166
Hibernia anomaly, Morrison County, N. J.	167
Uranium occurrences in Bucks County, Pa. and Hunterdon County, N. J.	167
South-central district, by E. P. Beroni	168
Texas	168
Arkansas	169
Oklahoma	170
North-central district, by R. C. Vickers	171
Nepheline syenite complex, Marathon County, Wisc.	171
McCutcheon Creek uranium occurrence, Iron County, Mich.	171
Bald Mountain gold-mining area, Northern Black Hills, S. Dak.	173
Colorado, by R. U. King	173
Ralston Creek district	173
Copperdale district	174
Lake George area, Park County	174
Shawnee area, Jefferson County	175

Wyoming, by J. D. Love	175
McComb area	175
Kermac No. 1 claim	175
Fox claim.	175
Hesitation claim no. 1	177
Mac claim.	177
South rim of Bates Hole	178
Saratoga area	179
Crooks Gap.	180
Southwest district, by R. B. Raup	180
Pearce district, Cochise Co., Arizona	180
Black Rock district, Yavapai Co., Ariz.	181
Tyrone district, Grant Co., N. Mex.	182
Nevada-Utah district, by A. O. Taylor.	182
Mystery-Sniffer mine, Beaver Co., Utah	183
Staats Fluorite mine, Beaver Co., Utah.	183
Gold Butte mining district, Clark Co., Nev.	183
Sheeprock and Simpson Mountains, Juab and Tooele Cos., Utah.	183
Northwest district, by F. C. Armstrong	184
California district, by H. G. Stephens	184
Reconnaissance for uranium in Alaska, by J. J. Matzko.	187
Analytical service and research on methods.	189
Sample control and processing, Washington and Denver, by J. J. Rowe.	189
Radioactivity.	189
Equipment and methods, by F. J. Flanagan.	189
Analysis and research, Washington, by F. E. Sentfle	191
Thorium analysis	191
Metamictization of zircons	191
Activation analysis.	192
Analysis and research, Denver, by J. R. Rosholt	192
Spectrography.	193
Spectrographic methods, Washington.	193
Emission spectroscopy, by C. L. Waring	193
Infrared spectroscopy, by R. G. Milkey	194
Spectrographic methods, Denver, by A. T. Myers	194
Chemistry	196
Analysis of raw materials, Washington, by Irving May.	196
Analysis of raw materials, Denver, by L. F. Rader, Jr. and Wayne Mountjoy.	197
Research on analytical methods.	198
The sampling problem in the determination of small percentages of uranium in igneous rocks, by Alexander Sherwood and F. S. Grimaldi	198
The determination of uranium by the spectrophoto- metric method, by H. I. Feinstein	199

Automatic titration of calcium and magnesium, by C. A. Kinser	199
The determination of aluminum by the ferron method in aluminum phosphate zone samples from the Florida phosphate deposits, by Maryse Delevaux and F. S. Grimaldi.	200
The determination of sodium and potassium by flame photometric methods on shale, siliceous, argilla- ceous, and phosphatic materials, by Irving May and L. B. Jenkins	200
Research associated with analysis of two mineral samples, by F. S. Grimaldi and Harry Levine	201
Note on the analysis of phosphate rock.	201
Geochemical and petrological research on basic principles.	202
Distribution of uranium in igneous complexes, by David Gottfried for E. S. Larsen, Jr.	202
Southern California Batholith.	203
San Bernardino County, Calif.	203
Adams tunnel, Colorado.	204
New England.	204
Boulder Batholith, Montana	205
Research on methods and techniques	205
Weathering, transportation, and redeposition of uranium, by R. M. Garrels.	206
Mineral synthesis, by G. Jansen, G. Magin, and R. Marvin.	207
Isotope geology and nuclear research, Washington, by F. E. Sentfle	208
Geochronology.	208
Light-mass analysis.	208
Portable mass spectrometer	210
Investigation of natural processes	210
Isotope geology of lead, by R. S. Cannon, Jr.	211
Crystallography of uranium and associated minerals, by H. T. Evans	214
Crystallography of uranium oxide hydrates.	214
New developments in methods of crystal structure	215
Compilation of crystallographic data on phosphate minerals	216
Radon and helium studies, by G. B. Gott	217
Mineralogic and petrographic services and research	220
Services.	220
Mineralogic services, Washington, by E. J. Dwornik	220
Public sample program	220
Special sample program.	220
Mineralogical services, Denver, by L. B. Riley	221
X-ray services, by G. E. Ashby	222
Electron microscopy, by E. J. Dwornik.	223
Research.	224
Research on methods and techniques in mineralogy and petrology, by E. J. Dwornik.	224
Properties of uranium-bearing minerals, by J. C. Rabbitt	226

Geophysical prospecting services and research on methods	228
Development and maintenance of radiation detection equipment, by W. W. Vaughn.	228
Airborne radioactivity surveying, by R. M. Moxham	232
Areas surveyed	232
Painted Desert area	233
Pinto-Chinle area, Arizona.	233
Kramer area, California	235
Fort Myers and Gardner areas, Florida.	235
Altamaha area, Georgia.	235
Folkston area, Georgia.	236
Edisto Island area, South Carolina.	236
Black Hills area, South Dakota.	237
White River badlands, South Dakota.	237
Arizona strip area, Utah.	237
Plans.	238
Physical behavior of radon, by A. S. Rogers	241
Absorption and scattering of gamma radiation, by A. Y. Sakakura.	241
Experimental	242
Cylindrical geometry experiments (simulated drill hole)	242
Plane geometry experiments.	242
Theoretical	243
Gamma-ray logging, by C. M. Bunker.	243
Calibration of gamma-ray logging equipment	243
Experimental work with simulated ore bodies.	244
Plans.	244
Resource studies, by W. S. Twenhofel, F. W. Osterwald, and R. L. Sutton	245

ILLUSTRATIONS

Figure	Page
1. Index map of part of the Colorado Plateau showing location of mapping projects	23
2. Index map of Western San Juan Mountains, Colo. mapping project	29
3. Index map of part of the Colorado Plateau area, showing location of photogeologic quadrangle maps	31
4. Gravimetric and aeromagnetic coverage through May 1954	48
5. Drill hole LP-530, permeability vs. water saturation, 76 feet above to top of ore zone.	57
6. Drill hole LP-530, permeability vs. water saturation, ore zone to 34 feet below	58
7. Drill hole LP-531, permeability vs. water saturation, 60 feet above to top of mineralized zone.	59
8. Drill hole LP-531, permeability vs. water saturation, mineralized zone to 54 feet below	60
9. Geologic map of the Powder River Basin, Wyoming., showing areas of known uranium occurrences and the status of geologic mapping.	65
10. Relationship between uranium deposits, structure, and stratigraphy in part of the Edgemont district, Fall River County, S. Dak.	68
11. Some anomalies at the Lion No. 4 trenches, Fall River County, S. Dak.	71
12. Principal known uranium deposits, Central City-Idaho Springs region, Colo.	76
13. Vertical longitudinal projection, Carroll mine, Central City district, Colo.	77
14. Paragenesis of vein-forming minerals, Wood vein, East Calhoun mine, Central City district, Colo.	82
15. Tentative paragenesis of vein-forming minerals, Almaden mine, Fall River area, Colo.	82
16. Tentative paragenesis of pitchblende and associated ore minerals, Stanley mine, Idaho Springs district, Colo.	84
17. Index map of the Ralston Buttes quadrangle, Jefferson County, Colo.	88
18. Reserves of uranium-bearing lignite in the HT Butte area, Slope County, N. Dak.	103
19. Reserves of uranium-bearing lignite in the northern part of the Chalky Buttes area, Slope County, N. Dak.	104
20. Reserves of uranium-bearing lignite in the southern part of the Chalky Buttes area, Slope County, N. Dak.	105
21. Reserves of uranium-bearing lignite in the Bullion Butte area, Billings and Golden Valley Counties, N. Dak.	106
22. Reserves of uranium-bearing lignite in the Sentinel Butte area, Golden Valley County, N. Dak.	107
23. Map showing area underlain by uranium-bearing lignite, Ekalaka Hills, Carter County, Mont.	110

Figure

24.	Stratigraphic sections showing correlation of lignite beds Ekalaka Hills, Carter County, Mont.	111
25.	Chart showing concentration and distribution of uranium in lignite beds, Ekalaka Hills, Carter County, Mont.	112
26.	Geologic map of the Mendenhall area, Slim Buttes, Harding County, S. Dak., showing locations of core drill holes.	115
27.	Maps showing thickness, grade, and distribution of uranium- bearing lignite in Mendenhall area, Harding County, S. Dak.	116
28.	Columnar section showing distribution of uranium in the Creston coal zone at Creston Ridge, Eastern Red Desert area, Sweetwater County, Wyo.	119
29.	Diagram showing distribution of selected trace elements in the Luman coal bed, core hole 72, sample interval 95.97 to 101.95 feet, Red Desert area, Sweetwater County, Wyo.	120
30.	Comparison of radioactivity values with apparent specific gravity and lithology of moist samples taken from 8" diam. core of Red Desert hole 72.	125
31.	Petrologic composition, pure basis, Red Desert hole 72.	128
32.	Map of Texas showing area of Cretaceous outcrop partially covered in reconnaissance and localities sampled.	134
33.	Index map showing black shale localities examined for uranium in the Rocky Mountain region.	137
34.	Detailed section showing the uranium content of carbonaceous shale, zone B, drill hole 2, Goose Creek district	140
35.	Sketch map of central Florida showing north and east edges of the Land-pebble phosphate district	151
36.	Geologic map of part of west central Florida, post middle Miocene removed.	153
37.	Sketch map of Wet Mountains area, Custer and Fremont Counties, Colo.	164
38.	Vein map showing radioactive localities, Wet Mountains, Custer and Fremont Counties, Colo.	165
39.	Map showing location of airborne anomalies and thorium- mineral occurrences near Wausau, Marathon County, Wisc.	172
40.	Map of Wyoming showing areas examined, Dec. 1, 1953 - May 31, 1954.	176
41.	Localities in Alaska to be examined for uranium deposits in 1954	188
42.	Scintillation counter for carborne application.	229
43.	Airborne radioactivity surveys, Dec. 1, 1953 - June 1, 1954	234
44.	Airborne radioactivity surveys scheduled, July-December 1954.	239
45.	Index map of Alaska showing locations of airborne radio- activity surveys, June-December 1954.	240

TABLES

Table	Page
1. Average chemical composition of ores and barren host rocks from sandstones and mudstones of the Colorado Plateau	43
2. Average chemical compositions of green mudstone, red mudstone, and sandstone from the ore zone of the Salt Wash member, Jo Dandy area, Montrose County, Colo.	44
3. Core properties near correlated ore-zone level showing weak radioactivity.	61
4. Core properties near ore zone, drill hole LP-530	62
5. Comparison of pore and spring water	63
6. Analyses of rocks, soils, and plant ashes from the Black Hills	69
7. Geochemical relationships of rocks and soils, Black Hills.	70
8. Data on samples from Carroll mine.	78
9. List of mines containing significant uranium deposits, Central City-Idaho Springs region, Colo.	80
10. Distribution of significant uranium-bearing minerals, Central City district, Colo.	81
11. Analytical data on samples from the Boulder batholith, Montana	92
12. Inferred reserves of uranium-bearing lignite in southwestern North Dakota	108
13. Measured reserves of lignite in the Mendenhall area.	113
14. Summary of inferred reserve data on radioactive lignite and uranium, Mendenhall area, Harding County, S. Dak.	114
15. Analytical data for organo-uranium extracts.	121
16. Tabulation of core processed at Coal Geology Laboratory for AEC projects.	130-131
17. Radioactivity and uranium content of sedimentary rocks of Texas (averages).	133
18. Uranium content of black shale at five localities in the northern Rocky Mountain region.	138
19. Sample types analyzed, asphaltite and petroleum.	143
20. Types and number of analyses, asphaltite and petroleum	144
21. Comparative analysis of a standard crude oil	144
22. The determination of arsenic by three independent methods	145
23. Formations recognized between Hernando and Hardee Counties, Fla.	154
24. Analyses of Tertiary limestones, west central Florida.	156
25. Analyses of apatite for tetravalent and total uranium.	158
26. Summary of analytical services and sample inventory, December 1, 1953 to May 31, 1954.	190
27. Standard sensitivities for the elements determined by the semi-quantitative method, Denver, May 31, 1954.	195

Table

28. Uranium content of minerals of the Southern California batholith	202
29. Uranium analyses of rocks from Rock Corral area, Calif.	203
30. Analyses of rocks from Adams tunnel, Colo.	204
31. Analyses of New England magmas	204
32. Age determinations (New England)	204
33. Lead isotope analyses, averaged.	214

INTRODUCTION

Since 1947 the Geological Survey, under the sponsorship of the Atomic Energy Commission, has undertaken investigations of radioactive materials in the United States and Alaska, and to a minor extent in foreign countries.

This report is a statement of progress during a six-months period and gives the principal unclassified information developed in that period. Many of the investigations discussed herein are sufficiently advanced so that final reports are in preparation for future publication with the permission of the AEC. Other studies are still far from complete and final reports cannot be expected for some years.

Formal publications (as distinguished from administrative Trace Elements reports) during this semiannual period, resulting from work done previously, consisted of 21 papers in two USGS bulletins, 20 USGS circulars, one USGS quadrangle map, and 42 papers, including abstracts, in technical journals. Also, eight Trace Elements reports were made available to the public through the Technical Information Service of the AEC. A total of 26 papers were presented by staff members before scientific societies.

The principal investigations conducted by the USGS continued to be in the Colorado Plateau region of Colorado, Utah, Arizona, and New Mexico, the chief area of uranium production in the United States. The large-scale drilling program on the Plateau was continued, but no exploration was undertaken elsewhere in the country during the period.

The highlights of the main field and laboratory projects underway are contained in the brief summary on pages 16 through 21.

SUMMARY

Uranium in sandstone-type deposits

Field work is completed for seven projects of the geologic mapping program in the Colorado Plateau. These are southwestern Colorado; Capitol Reef, Utah; Carrizo Mountains, Arizona and New Mexico; Monument Valley, Arizona; Monument Valley, Utah; Comb Ridge, Utah; and Red House Cliffs, Utah. Work started previously is being continued on three projects: San Rafael Swell, Utah; White Canyon, Utah; and Elk Ridge, Utah. Five mapping areas on which work has not yet started are: Inter-River, Utah; Lisbon Valley, Utah and Colorado; Abajo Mountains, Utah; Sage Plain, Utah and Colorado; and Circle Cliffs, Utah.

Geologic studies in the White Canyon area indicate that all significant uranium deposits occur in channels that have been cut into the Moenkopi formation and filled with sediments of the Shinarump conglomerate. Drill-hole data suggest that channels containing known ore deposits are filled with sediments that consist of 10 to 30 percent siltstone and claystone, whereas channels barren of ore deposits generally contain less than 10 percent siltstone and claystone.

In the Capitol Reef area radioactive rock was found in the Moenkopi formation, the Shinarump conglomerate, the Chinle formation, the Curtis formation, and the Salt Wash member of the Morrison formation. No uranium deposits in the area appear to be significant economically under present conditions.

On Elk Ridge uranium ore is present in at least three formations: the Moenkopi formation, the Shinarump conglomerate, and the Chinle formation. Most of the deposits are in discontinuous elongate sandstone lenses of Shinarump conglomerate. The uranium at Notch No. 5 claim is contained in petroleum, which impregnates Moenkopi sandstone. Removal of the petroleum from the sandstone also removes the uranium minerals.

Stratigraphic studies of Triassic rocks and associated formations indicate that the ore deposits in Triassic rocks are mainly in the Monitor Butte and Moss Back members of the Chinle formation, and in the Shinarump conglomerate.

Ground-water studies made during this period show large variations in permeability in samples within a formation. The average of permeabilities of samples from the same formation is slightly but possibly significantly different from the averages of samples for other formations.

Experimental plant studies have shown that plants are able to absorb uranium from carnotite concentrates, particularly in the presence of high sodium, but vanadium is not absorbed under such conditions.

Botanical prospecting in the San Rafael Swell, Utah, indicates that three species of Astragalus can be used as selenium indicators.

Study of distribution of elements has showed that copper, lead, molybdenum, nickel, cobalt, and selenium are associated with uranium and vanadium in the bedded deposits. The $V_2O_5:U_3O_8$ ratio is about 7 for Morrison ores and about 2 for Triassic ores.

Two new minerals, navajoite and rabbitite, have been described and two additional new minerals have been found but have not yet been described. Native selenium, a rare occurrence in association with uranium ores, was identified from the Peanut mine, Jo Dandy area, Montrose County, Colorado.

A self-potential study in the Happy Jack mine, White Canyon, Utah, showed small anomalies over mineralized zones having thin overburden, but no correlation was demonstrated between the self-potential measurements and ore zones buried by 200 feet of overburden.

In the Hideout mine, Deer Flat, White Canyon district, San Juan County, Utah, resistivity horizontal profiling revealed anomalies indicative of faults or fractures with trends in agreement with the strikes of fractures observed during geologic mapping of the area.

An aeromagnetic map of the Uravan area has been completed and compilation is proceeding for the rest of the region. Regional gravity maps of the Uravan and Inter-River areas have been prepared, and a gravity survey of the Monument Valley area has been largely completed. During the next six months gravity surveys will be made of parts of the White Canyon-Elk Ridge and San Rafael Swell areas, and reduction of data will continue.

Studies of original-state cores show that highly desaturated permeable sandstones, containing about 5 percent or less of pore water and having high electrical resistivity, are associated with poorly mineralized or barren rocks; moderately saturated permeable sandstones, containing about 25 percent of pore water and probably of intermediate resistivity, are found below the ore in drill hole LP-530. Thus, the degree of water saturation of the pores of permeable sandstone seems to bear an important relation to the occurrence of carnotite ore.

In the Black Hills, South Dakota, the most favorable host rock for uranium mineralization appears to be the Lakota sandstone; the deposits occur generally where the sandstone contains numerous mudstone "splits."

Uranium in veins, igneous rocks, and related deposits

Rehabilitation of the Carroll mine in the Central City district, Colorado, exposed a shoot of pitchblende ore that had been developed by earlier operators but not mined, presumably because of its low gold content. Further exploration will be undertaken to determine the full extent of the

shoot. The uranium at the Carroll mine, and at other mines on Nigger Hill, in the northern part of the Central City district, is associated with veins of the lead-zinc type. Paragenetically the pitchblende in the district is early and was deposited before the base-metals. The pitchblende in the Fall River area is also early in the mineral sequence. At Stanley Mines, however, the pitchblende is later than the base-metals. A study of the Tertiary dike rocks indicates that a characteristic carbonate-epidote alteration may be a guide to prospecting in areas not known to contain uranium deposits.

Several shipments of pitchblende ore have been made from the Schwartzwalder mine in the Ralston Buttes area, Jefferson County, Colorado. During the coming field season special emphasis will be given to areal mapping in the northern part of the Ralston Buttes quadrangle in the vicinity of the favorable "Rogers dike" structure.

Studies of the pitchblende deposits in the Golden Gate Canyon area in Jefferson County, Colorado, indicate that uranium deposition took place almost exclusively in hornblende gneiss rather than in other rocks of the pre-Cambrian complex. This is believed due to the presence of pyrrhotite in the gneiss. Ore deposition was preceded by the introduction of potash which converted much of the plagioclase in the wall rocks to orthoclase. Pitchblende formed prior to most of the associated sulfides.

Uranium in carbonaceous deposits

Reserves of radioactive lignite totalling about 30,000,000 tons in beds 3 to 11 feet thick and having an average uranium content of 0.008 percent have been estimated for the Mendenhall area at Slim Buttes, Harding County, South Dakota. Considerable reserves of uraniferous lignite have also been estimated for the Ekalaka lignite field, Carter County, Montana, and for the Bullion Butte, Sentinel Butte, HT Butte, and Chalky Butte areas in Slope, Golden Valley, and Billings Counties, North Dakota.

Studies of coal in the Eastern Red Desert, Sweetwater County, Wyoming, indicate that a close relationship exists between the occurrence of uranium and other trace elements in the coal and (1) the permeability of the enclosing strata and (2) the proximity of the coal to an unconformity overlain by once-extensive gravel deposits of Miocene or Pleistocene age. Spectrographic analyses show a close relationship of uranium to germanium, molybdenum, ytterbium, and yttrium in the coal, and chemical analyses show a similar relationship to iron.

Investigations at the USGS Coal Geology Laboratory indicate that highly degraded organic matter is most favorable to uranium emplacement, and that the purer coal as a rule contains the least uranium and the impure coaly layers the most.

Drill cuttings of the "Bakken shale" of Lower Mississippian age from Williams County, North Dakota, contain as much as 0.007 percent U, and gamma-ray logs of wells that penetrate the formation are being studied to determine the distribution of radioactivity.

Laboratory studies indicate that the uranium in the Chattanooga shale is dispersed through the organic material but probably is not chemically combined with it. Studies have been started on oil-impregnated sandstones, crude oil, and carbonaceous pellets associated with coalified wood in the San Rafael Swell. Spectrographic analyses show that the carbonaceous pellets contain ten of the 15 rare earths and that no sodium is detectable.

Uranium in phosphates

Northwest phosphate

At Sugar Pine Creek, Rich County, Utah, 15.4 feet of phosphate rock in the Phosphoria formation was found to contain 30.2 percent P_2O_5 ; 9.0 feet of this contains 32.3 percent P_2O_5 . The results of 118 selenium analyses recently made of Phosphoria formation rocks show that the highest selenium content (0.01 percent Se) is in highly phosphatic, petroliferous, and carbonaceous rocks; however, on the average highly phosphatic rocks contain much less selenium than those very low in phosphate.

Southeast phosphate

Three phosphate companies have completed drilling contracts with AEC and one company is still carrying out a contract. The four contracts cover the drilling of approximately 427 holes in land to be mined prior to 1965; of these about 350 holes have now been drilled and sampled.

The gamma-ray unit logged 318 holes for a total of 12,088 feet since December 1, 1953.

Tonnage and grade computations for the uranium content of the aluminum phosphate zone in the land-pebble field are nearly completed. Distribution and grade maps indicate that the thickest, most continuous, and highest grade material in uranium content underlies the flanks of the ridges and the flatwoods adjacent to the ridges.

Regional reconnaissance in the United States

Zircon from hornblende granite from Mine Mountain, near the Phillips mine area in Putnam and Westchester Counties, New York, was determined by the Larsen method to be 620 million years old; an age determination for the uraninite in the mineralized zone has been requested.

Samples from dump material at the Abe Lincoln mine, Black Rock district, Yavapai County, Arizona, contain as much as 0.46 percent U. Reserve tonnage and average grade of the uranium-bearing rock in the mine cannot now be determined because most of the mine workings are inaccessible.

The recent filing of a large number of claims on the Dripping Spring quartzite in Gila County, Arizona, attests to the increased public interest in uranium in that formation.

Analytical service and research on methods

During the reporting period 12,726 chemical determinations for uranium, 9,125 other chemical determinations, 181,271 spectrographic determinations, and 18,962 radioactivity determination were made in the Washington and Denver laboratories. A total of 16,263 samples were received during the period, and the backlog of samples was reduced from 21,237 on December 1 to 11,708 on May 31.

A patent, assigned to AEC, was issued on December 22, 1953, to Morris Slavin, Mary Fletcher, and Irving May on a transmission fluorimeter developed in the Washington laboratory for use in fluorimetric determinations of uranium. Modifications of this instrument are in regular use by USGS and other laboratories.

Experimental work was completed on a method of determining aluminum by the ferron method in samples from the aluminum phosphate zone of the Florida phosphate deposits. The method determines aluminum within ± 3 percent of the aluminum content of the sample, and although it is of general applicability it is especially useful in analyzing aluminum phosphate zone samples containing 0 to 40 percent P_2O_5 and 0 to 35 percent Al_2O_3 .

Geochemical and petrological research on basic principles

Analysis of the hydrogen-deuterium ratios of sea-water samples was attempted, using three samples obtained from widely separated oceanographic stations in the Atlantic Ocean, with a view toward obtaining hydrographic data that can be used in tracing water masses and in studying problems in the evaporation of sea water. As rain water and glacial water are relatively light in deuterium, local variations due to the introduction of such waters can be detected and measured. Evaporation, on the other hand, renders sea water heavier in deuterium. Results of the study are being interpreted in cooperation with scientists of the Woods Hole Oceanographic Institution.

Detailed subsurface information on the Western Panhandle Gas Field, Texas, indicates that the radon in the gas-producing formation is related to uranium-bearing asphaltic material which occurs as pellets and impregnations in dolomite and anhydrite. The occurrence of helium appears to be influenced by faulting.

Mineralogic and petrographic services and research

Complete chemical analyses were made of pure samples of eight uranium minerals including diderichite, synthetic diderichite, and synthetic liebigite. A study of volgite and uranosphaerite was completed and studies begun of supposed manganese autunite (fritcheite) and fully hydrated zeunerite. Development of a method for the simultaneous determinations of CO₂ and H₂O in minerals is in progress.

Geophysical prospecting services and research on methods

An instrument for measuring thermoluminescence, a newly designed scintillation detector for use in cars or light aircraft, a calibration device for gamma-ray logging instruments, an alarm attachment for carborne counters, a portable scintillation logging unit, and a core scanner utilizing a liquid phosphor have been developed to meet the requirements of special geologic studies. Airborne radioactivity surveys totalling 24,040 traverse miles have been made in seven states; the work included reconnaissance for sandstone-type uranium deposits, uraniferous phosphate, and thorium-bearing beach placers.

Modifications of the gamma-ray logging equipment have been made to insure stability and response to high intensity radiation. This work in turn necessitated recalibration of the instruments in order to determine accurately grade and thickness of radioactive material penetrated by drill holes. The calibration has been completed and a study of the accuracy of the technique is in progress.

An investigation of subsurface isorad radioactivity contouring techniques was made, the results indicating that additional study using scintillation logging equipment is warranted.

URANIUM IN SANDSTONE-TYPE DEPOSITS

Colorado Plateau geologic studies

Regional geologic mapping

Prior to the report period field work was completed for the following projects: Southwestern Colorado area; Monument Valley area, Ariz.; Red House Cliffs area, Utah; Carrizo Mountains area, Ariz. and N. Mex.; Capitol Reef area, Utah; and Comb Ridge area, Utah, all quadrangle mapping projects; and Monument Valley area, Utah, a strip mapping project (fig. 1).

During the period field and office work was continued on the White Canyon area, Utah, and Elk Ridge area, Utah, quadrangle mapping projects, and on the San Rafael Swell area, Utah, strip mapping project (fig. 1).

Work will begin early this summer for these projects: Lisbon Valley area, Utah and Colo.; Circle Cliffs area, Utah; Abajo Mountains area, Utah; and Sage Plain area, Utah and Colo., all quadrangle mapping projects; and Inter-River area, Utah, a strip mapping project (fig. 1).

Carrizo Mountains area, Ariz.-N. Mex., quadrangle mapping project,

by J. D. Strobell, Jr.

The 30-minute quadrangle surrounding the Carrizo Mountains in the northeastern corner of Arizona was mapped and studied to provide detailed information on the geologic occurrence of uranium deposits in the Salt Wash member of the Morrison formation.

Work in the current report period consisted of compiling the geology on the topographic base maps which became available in January. Analysis

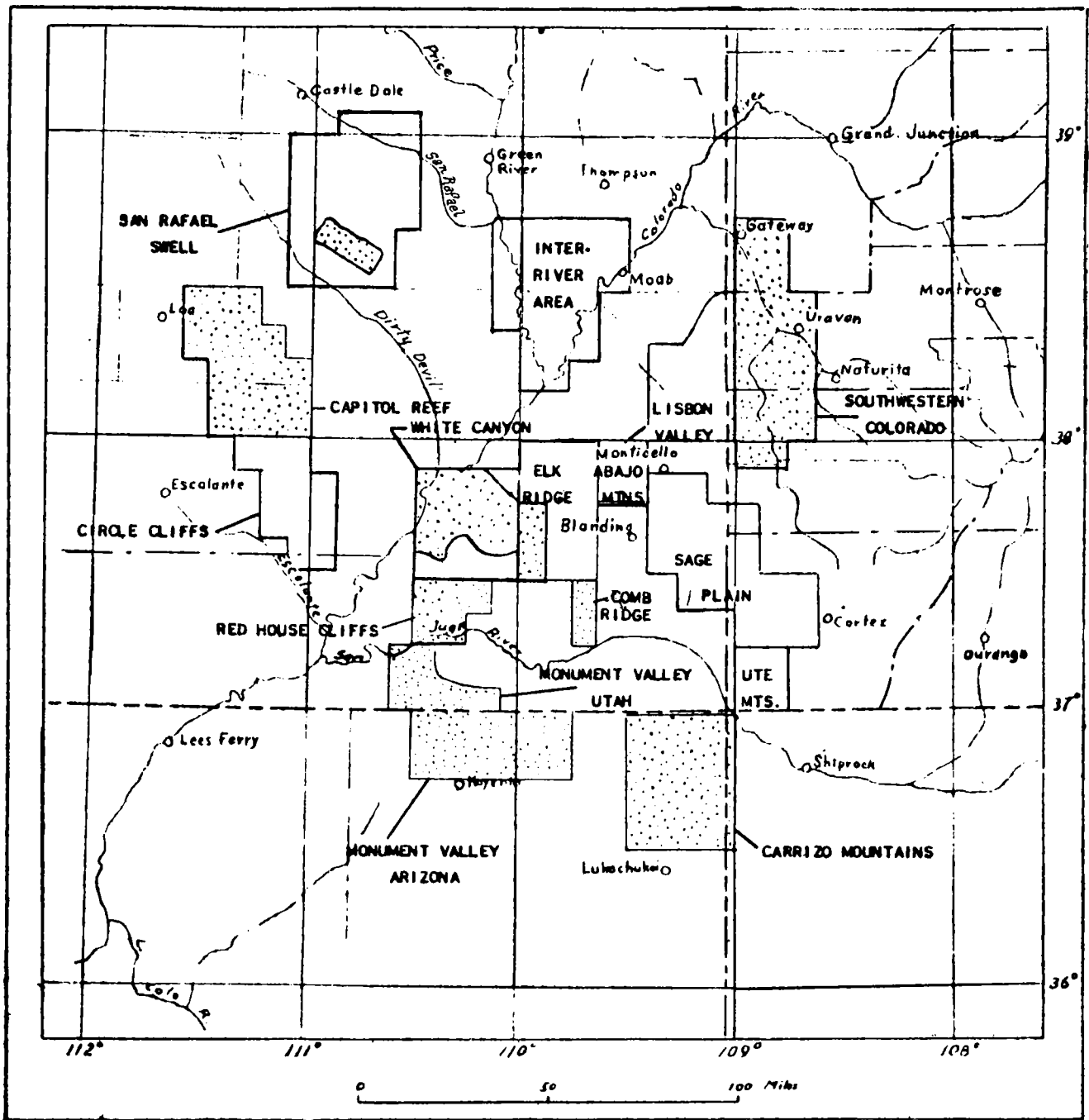

EXPLANATION

- AREA TO BE MAPPED
- AREA OF MAPPING COMPLETED MAY 1954

FIG. 1--INDEX MAP OF PART OF THE COLORADO PLATEAU SHOWING LOCATION OF MAPPING PROJECTS.

of the data and preparation of structure contours, text, and illustrations for the final report will occupy the next six months.

Red House Cliffs area, Utah, quadrangle mapping project, by T. E. Mullens

The Red House Cliffs area includes five $7\frac{1}{2}$ -minute quadrangles in southwestern San Juan County, Utah. These quadrangles cover exposures of Triassic formations on the western flank of the Monument upwarp between the White Canyon area and the Monument Valley, Utah, area.

Field work in the Red House Cliffs area was completed in 1953; compilation of data and preparation of a final report are in process.

White Canyon area, Utah, quadrangle mapping project, by A. F. Trites, Jr.

The White Canyon area is on the west flank of the Monument upwarp in the central part of San Juan County, about 50 miles west of Blanding.

Geologic studies in the White Canyon area indicate that all significant uranium deposits occur in channels in the Moenkopi formation filled with sediments of the Shinarump conglomerate. These channels range from less than 150 feet wide and 4 feet deep to more than 500 feet wide and 50 feet deep. Out of a total of 35 channels mapped in the White Canyon district, 11 are known to contain one or more ore deposits, and at least 10 more contain lower grade uraniumiferous material.

Compilation of much of the drill-hole data from the White Canyon area suggests that the sediments in ore-bearing channels contain from 10 to 30 percent siltstone and claystone, whereas channels barren of ore deposits generally contain less than 10 percent siltstone and claystone.

Detailed geologic study at the Jomac mine has helped clarify several questions pertaining to the nature of channels in the White Canyon area.

A channel at the Jomac mine was detected only after the restoration of the top of the Moenkopi formation to a horizontal position on the structure contour map; the channel is 200 to 400 feet wide and 4 feet deep and apparently was filled in part by Chinle-like siltstone and then scoured out and filled by sandstone and conglomerate of the Shinarump conglomerate. The edge of the channel appears to be marked in places by siltstone-pebble conglomerate which is believed to represent material that slumped from the upper banks of the stream and was incorporated into the stream sediments. The presence of such conglomerates may prove to be a guide in exploratory drilling for channels.

Studies of wood-orientation are believed to be important in determining the trend of channels, and as few as 40 observations may be sufficient; the size of wood fragments seems unimportant in these studies. Most of the wood fragments at the Jomac mine are oriented parallel to the channel trend.

Work during this period has consisted of preparation of manuscripts describing the White Canyon area and the Jomac mine, and compilation of diamond drilling data made available by AEC. Field work on the project will be completed during the 1954 field season when the upper part of Red Canyon will be mapped on a scale of 1:48,000. In this area the Shinarump conglomerate will be examined in detail, and the uranium deposits will be studied.

Capitol Reef area, Utah, quadrangle mapping project, by J. F. Smith, Jr.

The Capitol Reef area, Wayne and Garfield Counties, Utah, is along the border between the High Plateaus and the Canyon Lands of the Colorado Plateau province. About 850 square miles in this area were mapped. Radioactive rock was found in several formations, but no uranium deposits in the

area appear to be significant economically.

At a group of claims along Oak Creek, in the southeast part of the area, uraniferous rock is chiefly in a basal Shinarump bed of clay and sandstone containing carbonaceous material. It is along what appears to be a channel cut in the underlying Moenkopi formation and filled with Shinarump beds adjacent to a Shinarump pinchout and is exposed in several places over a distance of about 3,500 feet. The uranium content ranges from 0.002 percent to 0.094 percent in channel samples, and is as much as 0.30 percent in selected samples. Specks of metatorbernite (?) were noted at a few exposures. The uranium appears to be intimately associated with carbonaceous material at many localities.

Two 3-foot channel samples from the Billy's Dream claim in the Salt Wash member of the Morrison formation in the eastern part of the area contain 0.031 and 0.097 percent uranium and 0.22 and 0.20 percent V_2O_5 . The deposit at this claim is in a sandstone and conglomerate lens at the top of the Salt Wash member.

Elk Ridge area, Utah, quadrangle mapping project, by R. Q. Lewis, Sr.

Geologic mapping and field studies were started on Elk Ridge, San Juan County, Utah, in June 1953. During the first field season the southern part of Elk Ridge was mapped geologically and 150 miles of the Shinarump-Moenkopi and Chinle-Moenkopi contact was examined.

Uranium ore is present in at least three formations on Elk Ridge; the Moenkopi formation of Lower and Middle (?) Triassic age and the Shinarump conglomerate and Chinle formation of Upper Triassic age. Most of the deposits are in discontinuous elongate sandstone lenses of Shinarump conglomerate.

The ore at the Notch No. 5 claim, in a sandstone ledge in the Moenkopi formation, is petroliferous; the uranium is in the petroleum and is removed from the sandstone with the petroleum. No identifiable uranium minerals have been found in the sandstone. Semiquantitative spectroscopic analysis of the sandstone ore shows an association of thorium and rare earth elements which has not been noted in samples from the Shinarump conglomerate.

During the coming field season mapping and examination of the ore-bearing units will be continued to the north of the area previously covered.

Geochemical studies, to be started this year, and botanical studies, continued from last season, are expected to give considerable aid in the evaluation of areas where the bedrock is covered by talus and soil.

San Rafael Swell area, Utah, strip mapping project, by R. C. Robeck

As a result of several conferences and of brief supporting field studies, the main ore-bearing sandstone within the San Rafael Swell is now considered to be the Moss Back member of the Chinle formation; the Shinarump conglomerate is absent in many places in the San Rafael Swell.

Plans for the coming season include further strip mapping of the ore-bearing and associated strata and detailed study of the stratigraphic interval from the top of the Moenkopi formation to the top of the Moss Back sandstone.

Comb Ridge, Utah, quadrangle mapping project, by J. D. Sears

In the 1953 field season, the USGS completed geologic mapping along Comb Ridge, San Juan County, Utah. The completed map, a little over two 7½-minute quadrangles along Comb Ridge, includes the outcrop of all Triassic rocks along the east side of the Monument upwarp north of the San Juan

River and south of Elk Ridge, Utah. The main function of this project was to train geologists in mapping techniques. The project was financed entirely by the Geological Survey.

No unquestionable Shinarump conglomerate occurs in the area. A few lenses of gray to tan sandstone at the base of the Chinle formation were thought at first to represent the Shinarump. When Chinle-like material was found beneath these lenses, they were assigned instead to the Chinle.

Only one of the three main uranium ore-bearing formations of the Plateau occurs in the area, and no occurrences of uranium have been reported.

This map was transmitted as TEM-671, "Preliminary geologic map of the Comb Ridge area, San Juan County, Utah," by J. D. Sears and R. D. Sample.

Western San Juan Mountains, Colo., by A. L. Bush

Work during the reporting period consisted mainly of map compilation, library research, and laboratory study. The geologic mapping of approximately 30 square miles accomplished during the 1953 field season was compiled. Laboratory work consisted largely of petrographic study of thin sections of the barren and mineralized rocks. Field work was resumed on May 1, 1954.

The area mapped during the 1953 field season, and the area in which mapping will be done in the 1954 field season are shown in figure 2. Most of this season's work will be concentrated in the Coventry 4 SE quadrangle, aimed at completion of the mapping in this quadrangle this year. Geologic

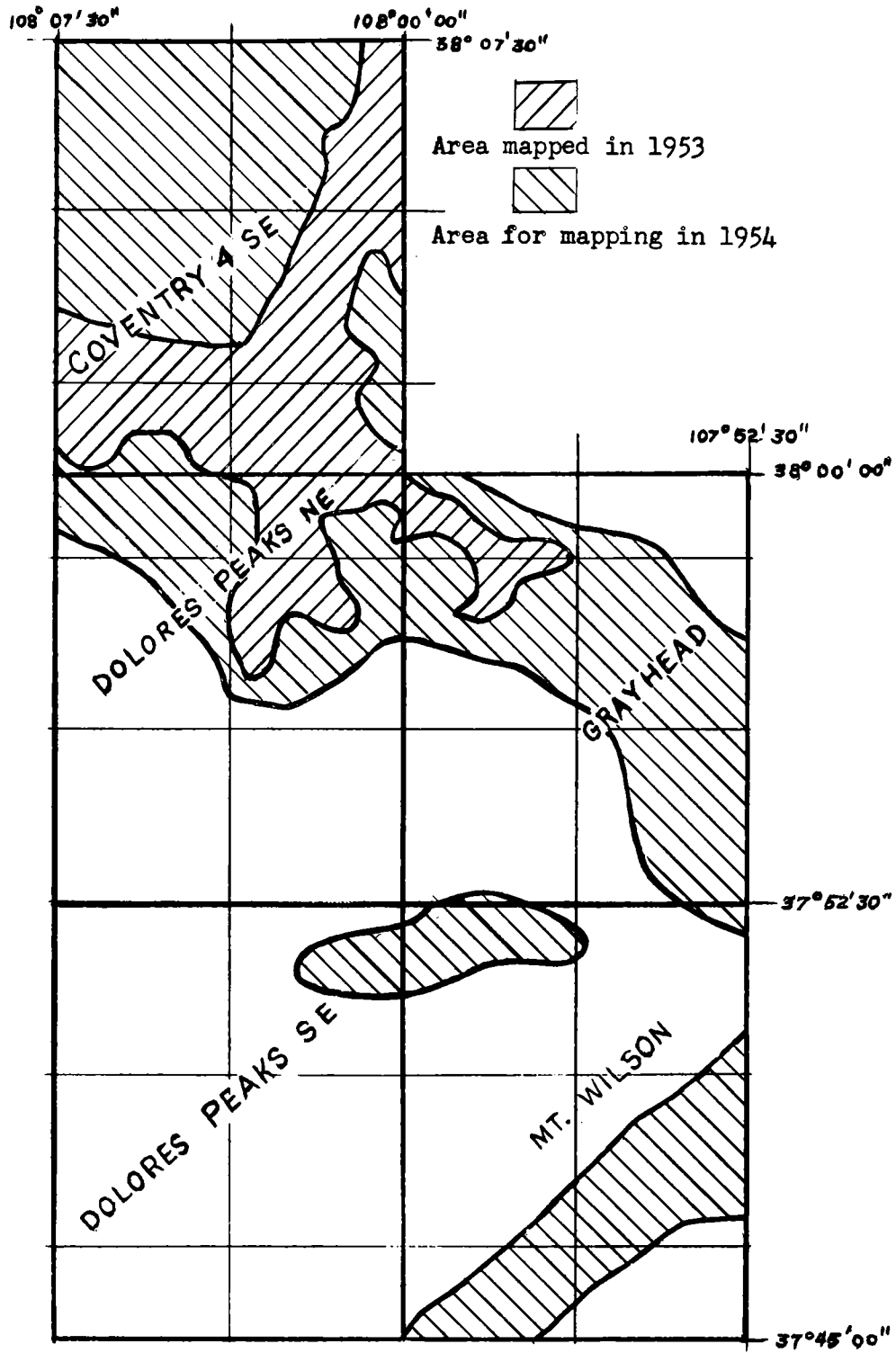

FIG. 2--INDEX MAP OF WESTERN SAN JUAN MOUNTAINS,
COLORADO MAPPING PROJECT.

mapping of the high mountainous country in the northern third of the Dolores Peaks SE and Mt. Wilson quadrangles also will be started.

Photogeologic mapping
by W. A. Fischer

The photogeologic mapping program is designed to provide regional geologic maps of specified areas in Utah and Arizona until such time as more detailed ground surveys can be made. Since the beginning of the program in the winter of 1951-52 approximately 15,000 square miles of mapping has been completed or is in the latter stages of production.

In addition to the regular mapping program, the Photogeology Section has completed a series of detailed studies of the surface expression of the Shinarump conglomerate. An isopachous map of the vicinity of Monument No. 2 mine has been completed and stereo-templet control has been obtained for an area of approximately 4,000 square miles in the vicinity of Zion Canyon; photogeologic mapping will begin in that area about July 1, 1954.

The progress of the photogeologic mapping program is shown on the index map (fig. 3).

Stratigraphic studies
by G. A. Williams

Morrison formation

Progress on a report summarizing the results of the stratigraphic studies of the Morrison has consisted of preparation of rough drafts of two segments of the report; these deal with the pebble studies and the lithofacies studies. The lithofacies report was transmitted as

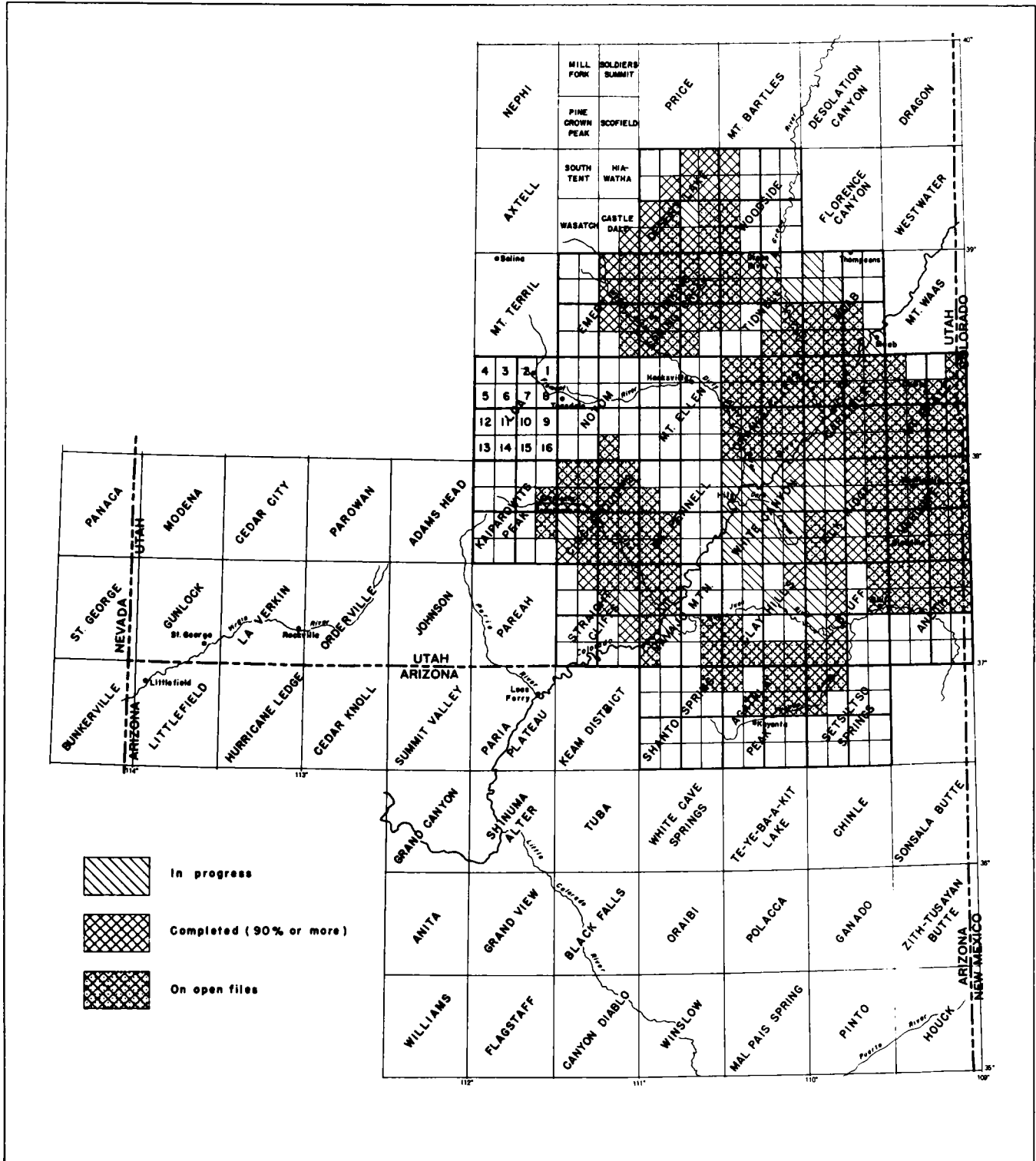

FIG. 3--INDEX MAP OF PART OF THE COLORADO PLATEAU AREA, SHOWING LOCATION OF PHOTOGEOLOGIC QUADRANGLE MAPS.

TEI-341, "Lithofacies of the Salt Wash member of the Morrison formation," by T. E. Mullens and V. L. Freeman. Results of the pebble studies will be incorporated in the final report on the Morrison.

Analysis of Morrison samples in the sedimentary petrology laboratory was completed. Previous optical study of 600 sandstone samples suggested the existence of regional and stratigraphic differences in the feldspar content of the sands. As a final check on this conclusion, 60 samples of disaggregated, acid-leached, silt-free sand consisting of 15 samples from each of the four members of the formation were analyzed by the flame photometric method for sodium, potassium, and calcium. The results were tested by the statistical analysis-of-variance technique to determine their dependability. The sodium, potassium, and calcium contents were then reconstituted as the feldspars orthoclase, albite, and anorthite. It was found that the members of the Morrison formation contain significantly different amounts of reconstituted feldspar. Thus, the expected range of mean total feldspar content of the various members of the Morrison (at the 95 percent level of significance) is:

Recapture member	13.4 to 10.6 percent
Westwater Canyon member	14.5 to 9.5 percent
Salt Wash member	7.1 to 4.9 percent
Brushy Basin member	4.9 to 3.1 percent

Calcic plagioclase constitutes probably less than one percent of the average sandstone of the Morrison formation; sodic feldspars constitute the major plagioclase minerals in the Morrison sandstones. The ratio of potash feldspar to sodic feldspar is about 2:1 in the average sandstone of the Morrison formation. This ratio does not vary significantly over the region but is maintained in all four members of the

Morrison. The chance of detecting hypothetical sources of igneous rocks on this basis is slight.

Triassic and associated formations

Much of the report period was used in compiling data and preparing an interim report on the stratigraphy of the Triassic and associated formations in southeastern Utah and adjoining parts of Arizona.

The Permian Cutler formation grades from a typical arkose facies in southwestern Colorado to an alternating reddish siltstone and light-colored sandstone facies in southeastern Utah.

The reddish siltstones were probably deposited in quiet waters in slowly sinking marginal continental basins and probably were derived from a source area in southwestern Colorado. The light-colored sandstones were probably deposited by winds blowing to the southeast and were probably derived from a source area to the northwest of southeastern Utah and possibly to some extent from reworking of the underlying reddish siltstone units in the Cutler.

The Moenkopi formation is interpreted to be dominantly a tidal flat deposit containing minor amounts of stream-deposited material. The streams flowed to the west, probably from a highland in southwestern Colorado. The Sinbad limestone member is a marine deposit. The sea in which the Sinbad limestone was deposited probably transgressed from the northwest and west across Utah.

The deposition of the Moenkopi formation was followed by a period of erosion, referred to as the mid-Triassic unconformity. The Shinarump conglomerate or, in its absence, the Chinle formation, was deposited on

this erosion surface. In a few places both the Moenkopi formation and the Shinarump conglomerate are absent and the Chinle formation was deposited directly on Permian rocks.

The Upper Triassic Shinarump conglomerate is a fine- to coarse-grained sandstone which contains conglomeratic lenses composed dominantly of siliceous pebbles, and is interpreted to have been deposited in streams which flowed to the northwest and had a source to the southeast, as is indicated by the resultant dip of the cross-strata.

The Upper Triassic Chinle formation in southeastern Utah and Monument Valley, Ariz., can be divided into five as yet undescribed members which will probably be named the Monitor Butte, Moss Back, Petrified Forest, Owl Rock, and Church Rock members after consideration by the Geologic Names Committee of the Geological Survey. Differences between the members generally are small and the members intertongue to a high degree.

The Chinle formation is probably a continental deposit formed under alluvial plain and lake or lagoonal environments. The Monitor Butte, Moss Back, and Petrified Forest members contain much volcanic debris. The direction of dip of the cross-strata in most of the units in the Chinle indicates a northwest direction of transport and suggests a source to the southeast of southeastern Utah.

The Glen Canyon group consists of the Upper Triassic Wingate sandstone, Upper Triassic (?) Moenave formation (not yet described), Jurassic(?) Kayenta formation, and Jurassic Navajo sandstone. Preliminary studies indicate that the sedimentary structures dip in a southeasterly to southwesterly direction, and presumably the source area of Glen Canyon sediments was northwest of southeastern Utah.

The ore deposits in the Triassic rocks in southeastern Utah are mostly in the Shinarump conglomerate and the Monitor Butte and Moss Back members of the Chinle formation. The deposits in the Shinarump conglomerate, and in the Monitor Butte and Moss Back members, occur in broad northwest-trending belts near the northern limit of the respective units. Geologic features in the host rock that appear to be associated with ore deposits and thus could be used as guides to ore are (1) pinch-outs, (2) channels, (3) the presence of lenticular sandstone and mudstone units, conglomerate, and carbonaceous plant material, and (4) the presence of 20 percent or more kaolin.

Most of the ore deposits in the Shinarump conglomerate and Chinle formation are found near the mid-Triassic unconformity regardless of the unit that lies near the unconformity. Possibly this relation is caused by (1) the inability of rising ore-bearing solutions to pass through the Chinle, (2) the inability of downward migrating ore-bearing solutions to pass through the Moenkopi, (3) the presence, in the unit overlying the Moenkopi, of chemical substances derived from soils on top of the Moenkopi that served to localize deposits, or (4) the increased permeability resulting from fractures in channels caused by the resistance offered by channels to bedding plane slip during folding.

In the 1954 field season stratigraphic studies will be extended eastward into easternmost Utah and western Colorado and into the Defiance Uplift area of northeastern Arizona.

Ground-water studies
by D. A. Jobin

Most of the report period was spent in measuring and analyzing the permeability of samples collected in 1953.

Data obtained in measuring the permeability include (1) the relationship of permeability to texture and composition of the sample, (2) the difference in permeability values obtained by successive use of nitrogen and of water as permeating media, and (3) the magnitude of local variation of permeability within a formation, and the magnitude of local variations among formations.

Scrutiny of this data shows the following:

1. Permeability is related to texture, and possibly a formula using some combination of measures of textures can be derived to calculate permeability. Work to derive such a formula is now in progress.

2. Adjusted values of permeability obtained with nitrogen agree closely with values obtained with water. This indicates that the use of a nitrogen permeameter to determine permeabilities is acceptable, at least for rocks of texture and composition similar to those used in the tests. The use of a nitrogen permeameter will make possible a 5- to 10-fold increase in the number of measurements made per unit time as compared to the number of measurements made with a water permeameter.

3. The large variations in permeabilities within formations coupled with the slight differences among formations necessitates more intensive sampling than that done in the past. Apparently a 3- to 5-fold increase in sampling will be necessary. The sample requirements will be tested in two selected areas during the next report period.

It is planned to reappraise the ground-water program with respect to the expected results and the large number of samples apparently necessary to obtain these results, and a report will be prepared summarizing the method and application of permeability as derived from measures of the rock textures.

Botanical studies

Botanical research, by H. L. Cannon.

Brief visits were paid to uraniferous deposits near Myton, Uintah County, Utah; Baggs, Carbon County, Wyo.; and Black Mesa and Defiance Uplift, Apache County, Ariz. Of these areas, the Black Mesa area appears most favorable for prospecting by analysis of absorber plants. At Black Mesa, carnotite ore occurs in a coarse sandstone near the top of the Mesa-verde formation of Cretaceous age. The mineralized sandstone forms the top of the mesa and is covered with a dense stand of pinyon and juniper trees. The depth to the ore zone is not more than 30 feet, and plant sampling of anomalous areas delineated by airborne radiation traverse would be a feasible method of prospecting.

Uranium-bearing lake beds of the Green River formation of Eocene age occur at Poison Buttes, a highly seleniferous area west of Baggs, Wyo. The uranium prospects are associated with Astragalus bisulcatus in at least part of the area. An indicator plant survey of this area would assist the prospecting.

An experimental garden plot in which desert plants were grown in different concentrations of several minerals containing basic nutrient elements, has yielded information of direct importance to botanical prospecting. Chemical analyses for uranium, vanadium, selenium, sulfur, potassium, calcium, and sodium made on the plants showed that they were able to absorb uranium from carnotite concentrates, particularly in the presence of high sodium, but that vanadium was not absorbed from the carnotite concentrates. Base exchange studies are in progress to determine the relation of vanadium to the clay fraction.

Botanical research under controlled conditions will be continued in plot experiments. Research on methods of sampling and analyzing soils, humus, and plant material by chromatographic methods will be started on Elk Ridge, Utah, during the next report period.

Botanical prospecting, by P. F. Narten.

The compilation of data was continued on the botanical prospecting projects in the Grants district, Valencia and McKinley Counties, N. Mex.; the San Rafael Swell area, Emery County, Utah; and the Trachyte Ranch deposits, Garfield County, Utah.

In the San Rafael Swell area, Emery County, Utah, partial analytical data indicate that three species of Astragalus (A. dodgeanus, A. osterhouti?, and A. preussi) can be used as selenium indicators. Astragalus preussi was observed only in the northwest part of the Swell and its distribution seems to reflect the selenium content of the lower Chinle mudstones. Astragalus dodgeanus is essentially limited to Temple Mountain and adjacent areas, but occurs in small numbers in the Green Vein Mesa area on the west-central side of the San Rafael Swell. Almost all occurrences of the selenium-indicating Astragalus species away from the Temple Mountain-Shinarump Mesa areas are associated with mudstones in the Moenkopi formation or the basal part of the Chinle formation and not with the ore-bearing Moss Back member of the Chinle formation. Inconclusive results were obtained on the usefulness of the absorber plant method in the San Rafael Swell and a limited sampling program will be carried on during June 1954 to obtain additional information.

In 1953, the absorber-plant method was used to prospect more than 40 miles of outcrop of the Shinarump conglomerate in the Deer Flat and Elk

Ridge areas in San Juan County, Utah. It is expected that the most promising of the anomalous areas on Deer Flat will be explored. The initial sampling on Elk Ridge has served to provide control for additional sampling during 1954.

It is planned to map the selenium-indicator plant, Astragalus pattersonii, where it occurs on sandstones of the Morrison formation in the Grants district, McKinley County, N. Mex.

Reconnaissance has shown that both indicator- and absorber-plant methods may be effective in prospecting for ground favorable for ore deposits in the Circle Cliffs area, Garfield County, Utah. A botanical project will be started in the area during the summer.

A final evaluation of the indicator-plant method in the area drilled by the USGS at Yellow Cat, Grand County, Utah, will be completed following a statistical study of plant and drill-hole data.

Resource appraisal

Ore distribution study, by C.C. Gilbert

Compilation of information about the known uranium deposits and favorable ground within the Salt Wash member of the Morrison formation in western Colorado was continued. Data were collected for parts of the Bull Canyon, Gypsum Valley, and Slick Rock districts. This data will be on the basis for a progress report aimed at relating distribution of uranium deposits to geologic features.

Reconnaissance resource appraisal, by H. S. Johnson

The reconnaissance resource appraisal has been extended to study the uranium deposits in all formations on the Colorado Plateau. The

objectives are to determine the order of magnitude of the uranium resources of each formation in each mining district on the Colorado Plateau and to contribute to an understanding of the origin and controls of ore deposits. The realization of these objectives will be of assistance in planning future exploration.

Most of the period was spent in writing reports, reviewing and compiling basic data, and making preliminary field investigations in preparation for work to be done this summer. The following reports were completed: TEM-287, "Geology of the Shinarump No. 1 uranium mine, Seven Mile Canyon area, Grand County, Utah," by W. I. Finch, and TEI-328, "Geologic aspect of the resource appraisal of uranium deposits in pre-Morrison formations of the Colorado Plateau," by W. I. Finch.

Mineralogic studies

General mineralogic studies, by T. Botinelly and A. D. Weeks

A special preliminary report on mineralogic and chemical characteristics of the ores in the Jo Dandy area, Montrose County, Colo., was completed. This work was requested by the AEC to assist in determining the amenability of the ore to treatment by a specific metallurgical process. The study of the mineralogy and composition of mill pulps and drill core splits indicate that certain troublesome elements and minerals are not present in amounts or combinations above the tolerance of the metallurgical process.

A study of red and green clays from both productive and nonproductive areas showed that the gross mineralogy of the two colors of clay is the same. Kaolinite is accessory to illite in the majority of clays

associated with ore, but is absent from most of those in barren localities. This preliminary observation suggests that a causal relationship may exist between the occurrences of kaolinite and of ore.

Descriptions of two new minerals were completed, TEI-393, "Navajoite, a new vanadium oxide from Arizona," and TEI-405, "Rabbittite, a new uranyl carbonate from Utah." These reports will be published in professional journals. Another new mineral to be named abernathyite was discovered and the description is nearly completed. An unknown mineral was found in the Wind River Basin, Wyo., but has not yet been described.

Liebigite, formerly thought to have the formula $\text{Ca}_2\text{U}(\text{CO}_3)_4 \cdot 10\text{H}_2\text{O}$ was found instead to have the formula $\text{Ca}_2(\text{UO}_2)(\text{CO}_3)_3 \cdot 10-11\text{H}_2\text{O}$. The similarity between the true formula of liebigite and bayleyite is interesting because the two minerals seem to form under similar conditions at Pumpkin Buttes, Wyo.

Native selenium was identified from the Peanut mine, Jo Dandy area, Montrose County, Colo. It was previously reported from the Edgemont area of South Dakota (1953).

About 0.6 g of a black corvusite-like mineral from the Monument No. 2 mine, Apache County, Ariz., was purified for chemical analysis. The unit cell length along the fibers was determined to be 3.65Å. The mineral is possibly of monoclinic symmetry and elongated parallel to the b-axis as hewettite, sodium-vanadate, and navajoite are known to be.

Met~~a~~autunite is the chief uranium mineral in four samples from the Wind River Basin, Wyo. Three of the samples contain arsenic, in smaller amount than phosphorus.

A revised version of TEI-334, "Identification and occurrence of uranium and vanadium minerals on the Colorado Plateau," by A. D. Weeks and M. E. Thompson was published as USGS Bull. 1009-B.

Distribution of elements, by W. L. Newman

A study of trace metal content of bedded uranium deposits and of the barren sandstone host rocks was made to determine which metals were added to the host rocks during uranium-vanadium mineralization and to provide gross quantitative measures of the additions. Analyses have been completed on about 1,000 samples of ores and barren rocks from the Colorado Plateau.

Table 1 shows the average chemical composition of ores and barren host rocks from the two chief ore-bearing zones on the Colorado Plateau. As shown in the table, the following heavy metals are associated with uranium and vanadium in the bedded deposits: copper, lead, molybdenum, nickel, and cobalt. Special analyses on selected suites of samples indicate that selenium is also concentrated in the deposits.

Other analyses show that the $V_2O_5:U_3O_8$ ratio averages about seven for the Morrison ores and about two for the Triassic ores, and that barren Morrison sandstones (Salt Wash member) contain about 0.0001 percent uranium and about 0.001 percent vanadium. Although the barren sandstone contains only 0.0001 percent uranium it averages about 0.001 percent eU.

The geographic and stratigraphic variations in trace metal content of the barren Salt Wash sandstone indicate that the Salt Wash is homogeneous. Comparison of average compositions of the uppermost sandstone ledge (the chief ore-bearing sandstone), the basal sandstone ledge, and the intermediate sandstone ledges shows no significant differences. Geographic "highs" of zirconium, titanium, chromium, and yttrium suggest

Table 1.--Average chemical composition of ores and barren host rocks from sandstones and mudstones of the Colorado Plateau

Element	Barren Morrison sandstone <u>1</u> / Average percent (Geometric mean)	Morrison ore <u>2</u> / Average percent (Geometric mean)	Barren Triassic sandstone <u>3</u> / Average percent (Geometric mean)	Triassic ore <u>4</u> / Average percent (Geometric mean)
Al	1.2	2.3	3.3	2.6
Na	0.09	0.09	0.09	0.09
K	<0.10	<0.10	0.15	0.54
Ca	3.3	2.1	0.25	0.81
Ba	0.03	0.09	0.05	0.08
Sr	0.005	0.013	0.006	0.016
Mg	0.23	0.57	0.13	0.20
B	<0.001	0.001	<0.001	0.001
Fe	0.24	0.82	1.2	1.5
Mn	0.02	0.03	0.01	0.03
Ti	0.05	0.10	0.18	0.15
Zr	0.01	0.03	0.03	0.02
Cr	0.0007	0.002	0.001	0.002
Cu	0.001	0.01	0.01	0.05
Pb	<0.001	0.007	0.001	0.007
Mo	<0.001	0.001	0.001	0.003
Ni	<0.0003	0.0008	0.0008	0.003
Co	<0.0003	0.001	0.0005	0.002
Y	<0.0001	0.001	0.002	0.002

1/ Averages based on 96 barren sandstone samples.

2/ Averages based on 202 combined mill pulps from 151 mines.

3/ Averages based on 32 barren sandstone samples.

4/ Averages based on 86 combined mill pulps from 27 mines.

three granitic source areas for Salt Wash detritals: an area south of the Four Corners, an area in north-central Utah, and an area in north-western Colorado in the vicinity of Meeker. No other anomalous geographic distribution was noted.

Table 2 shows the average chemical compositions of green mudstones, red mudstones, and sandstones in the Jo Dandy area, Montrose County, Colo.

Table 2.--Average chemical compositions of green mudstone, red mudstone, and sandstone from the ore zone of the Salt Wash member, Jo Dandy area, Montrose County, Colorado

Element	Green mudstone <u>1</u> / Average percent (Geometric mean)	Red mudstone <u>2</u> / Average percent (Geometric mean)	Sandstone <u>3</u> / Average percent (Geometric mean)
Al	4.0	3.0	0.70
Na	0.2	0.2	0.05
K	2.0	2.0	0.60
Ca	0.94	1.86	1.81
Ba	0.017	0.014	0.016
Sr	0.010	0.010	0.006
Mg	1.6	1.8	0.40
Fe	1.4	1.5	0.30
Mn	0.016	0.026	0.012
Ti	0.10	0.10	0.03
Zr	0.009	0.007	0.004
Cr	0.003	0.003	0.0006
Cu	0.002	0.002	0.0007
Pb	0.0009	0.001	< 0.0005
Mo	0.0005	< 0.0005	< 0.0005
Ni	0.001	0.001	0.0002
Co	0.0004	0.0006	0.0001
V	0.008	0.006	0.004
Ga	0.0008	0.0006	< 0.0002
Sc	0.001	0.001	< 0.0005
B	0.004	0.004	0.0009
Y	0.002	0.002	< 0.0002

1/ Averages based on 19 drill core samples.

2/ Averages based on 13 drill core samples.

3/ Averages based on 40 drill core samples.

Comparisons of trace metal content from the two colors of mudstone from the "ore zone" of the Jo Dandy area disclose no significant differences. Red mudstone, however, contains twice as much calcium as green mudstone. Mudstones of the Salt Wash member at Jo Dandy contain greater amounts of

aluminum, the alkalies, iron, magnesium, strontium, titanium, chromium, gallium, scandium, boron, yttrium, vanadium, nickel, cobalt, copper, and lead than the ore-zone sandstone contains.

Cenozoic studies

Cenozoic studies have been recessed during this report period except for the editing and processing of a comprehensive report which summarizes what is known concerning the Cenozoic history of the Colorado Plateau. Although the project has been inactive, contributions to the knowledge of the details of the Cenozoic history have been made by the regional mapping projects.

District geophysical studies by R. A. Black

Field work on the district studies project was recessed in December 1953 with the exception of the electric logging program, which was continued until January 1954 in the Long Park area, Montrose County, Colo.

In compiling the electric log data from the Long Park project, the following six basic parameters of the ore-bearing sandstone were measured, and an attempt was made to establish a correlation between each of them and geologic favorableness of the sandstone:

1. Apparent resistivity
2. Average resistivity
3. True resistivity
4. Average spontaneous potential
5. Maximum spontaneous potential
6. Resistivity gradient

The majority of the parameters for specific drill holes showed a poor correlation with geologic values assigned these same drill holes

by the project geologist at Long Park. The most promising parameter was the true resistivity of the lower section of the ore-bearing sandstone, but even here some values were erratic. Some of the lack of correlation is undoubtedly due to poor calibration and electrode leakage which were present during early stages of the logging program, but probably an insufficient amount of electric log information has been obtained in the Morrison to permit detailed favorability correlation. The electric log information obtained during the coming field season may make it possible to reach a definite conclusion as to the usefulness of electric logs in prospecting.

Extensive equipment modification was accomplished during the winter months. The electric logging unit and the resistivity surface-inhole unit were installed in van-body Dodge power wagons and a jeep station wagon was modified to serve as a seismic refraction instrument truck. New seismic cables and an inhole velocity cable were procured. The velocity cable, which contains 12 piezo-electric detectors, will permit determination of the velocities of a number of subsurface strata with one surface shot. The information obtained from such inhole velocity surveys will assist interpretation of surface seismic profiles.

Modification of standard Midwestern reflection seismic equipment to permit the recording of shallow reflections has been accomplished. This equipment has been field tested and will be available for testing and application to prospecting problems on the Colorado Plateau during this coming field season. A shot hole drill rig and water truck are available for use with the reflection unit.

Field work on the district studies project was resumed in May 1954. The refraction seismic crew is presently at work on Deer Flat, San Juan County, Utah, shooting surface refraction profiles and testing the inhole velocity cable. The standard electric logging unit is at Deer Flat obtaining electric logs of the holes currently being drilled there by the USGS.

Plans for the next six months include testing of the shallow reflection seismic equipment in Monument Valley, Ariz., and in the Deer Flat area, Utah; refraction seismic surveys at Holiday Mesa, Utah, and in other areas in Utah and Arizona; electric logging in a number of Shinarump and Salt Wash areas; magnetic ground surveys in more detail of various aeromagnetic anomalies; application of surface-inhole resistivity techniques to Shinarump areas; geothermal measurements at Temple Mountain, Utah; and a sampling program to obtain magnetic susceptibility of the various igneous rocks on the Colorado Plateau.

Regional geophysical studies
by H. R. Joesting and P. E. Byerly

Aeromagnetic surveys

Aeromagnetic surveys made to date on the Colorado Plateau are shown in fig. 4. During February 1954 an area in Utah bounded by Lat. $38^{\circ}30'N$ and $39^{\circ}N$ and by Long. $109^{\circ}W$ and $111^{\circ}W$ was flown. This area, totalling about 3,200 square miles, includes the Thompsons district and most of the Green River Desert and San Rafael Swell. Two short traverses were also flown over Upheaval Dome in the Inter-River area.

An aeromagnetic compilation unit was established at the Grand Junction Office in April to speed compilation of data and preparation of maps. Supervisory personnel previously trained in Washington are

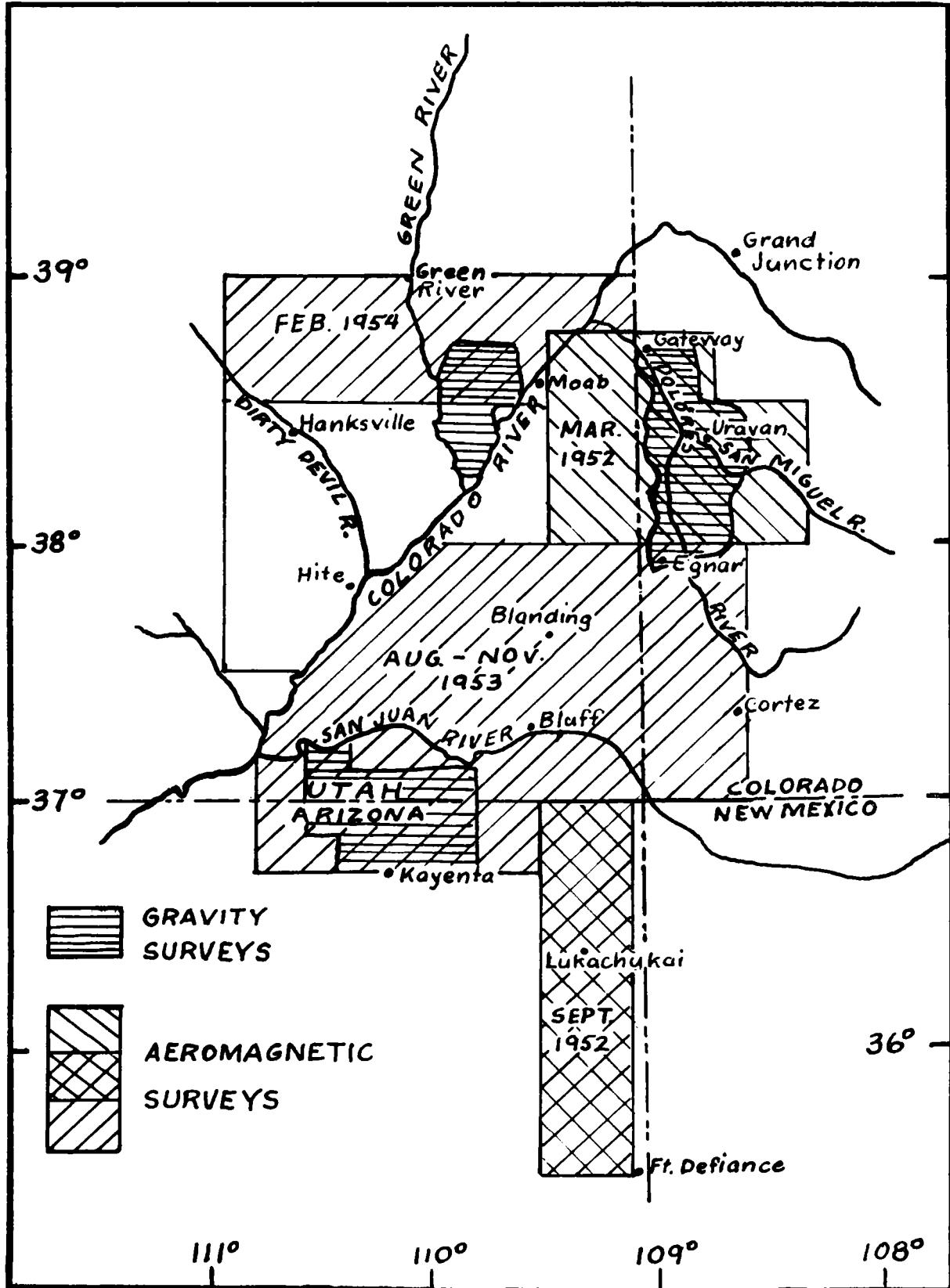

FIG. 4--GRAVIMETRIC AND AEROMAGNETIC COVERAGE THROUGH MAY 1954.

training compilers. Compilation of airborne data obtained Aug.-Nov. 1953 has been started.

Gravimetric surveys

Regional gravity surveys will eventually be made in much of the region outlined in fig. 4. The choice of individual areas for survey is determined by the availability of $7\frac{1}{2}$ minute multiplex maps, which are being prepared of much of the Colorado Plateau. These maps are suitable for horizontal location of gravity stations, and together with altimetry, are also suitable for vertical control.

The general procedure established in making regional gravity surveys in the Plateau is first to establish a base net of gravity stations by standard looping methods; then to occupy at intervals of one to two miles all gravity stations that are accessible by car; then to prepare a preliminary Bouguer gravity map; and finally to return to the field and complete the survey by filling in critical gaps indicated by an analysis of the preliminary map. This procedure saves considerable time by reducing to a minimum both foot traverses and unnecessary stations, and is especially advantageous during the present period of expanding prospecting and mining operations, when many new access roads are being established.

The first three phases of the procedure just outlined have been completed in the Uravan area, Colorado, and in the Inter-River area, Utah. Field work was carried out in the Uravan area during the summer of 1953, and in the Inter-River area during the fall and winter of 1953. Office compilation, including terrain corrections to all stations, was carried out subsequently and preliminary Bouguer maps prepared. Fill-in

surveys in these areas, including some foot traverses, will be made during the summer of 1954, and a revised gravity map will then be prepared. A preliminary gravity survey of the Monument Valley area of southeastern Utah and northeastern Arizona has been essentially completed, but most of the data remain to be compiled.

A total of about 1,300 gravity stations, including base-net stations, have been established to date. These include 630 stations in twenty-one $7\frac{1}{2}$ minute quadrangles in the Uruvan area, 145 stations in nine quadrangles in the Inter-River area, and about 480 stations in 20 quadrangles in the Monument Valley area. All stations are tied to the Coast and Geodetic Survey pendulum station at Egnar, Colorado.

The maximum horizontal error in locating gravity stations is about 0.1 mile, using the available 1:24,000 multiplex maps. The vertical error in the Uruvan area, where the maps have considerable vertical control and a 20 foot contour interval, is not over five feet, equivalent to about 0.3 mgal. In the Inter-River and Monument Valley areas where there is less vertical control and the contour interval of the maps is 40 feet, it has been necessary to use bench marks and other previously surveyed elevations, plus short altimeter traverses. Ten feet, corresponding to 0.6 mgals, is the maximum vertical error allowed for altimeter elevations. Bench marks and surveyed elevations are of course more accurately known.

Standard methods were used in reducing the field data. Latitude corrections were made according to the International Formula and the combined mass and elevation correction was 0.062 mgal per foot, based on an experimentally determined rock density of 2.5 gm per cm³.

Topographic corrections were made according to Hammer's terrain correction tables, again assuming an average density of 2.5 gm per cm³. The total error in the reduced gravity values probably does not exceed one-half mgal in the Uravan area, and one mgal in the Inter-River and Monument Valley areas.

Preliminary analysis of geophysical results

Uravan area.--In the Uravan area the following major magnetic features are recognized: a northwest-striking regional trend between the Uncompahgre Plateau and Disappointment syncline, with intensity increasing toward the plateau; an east-west trend north and south of the La Sal Mountains, with intensity increasing toward the mountains; moderate anomalies with no distinctive trend southwest of Disappointment syncline; and a prominent trough coinciding with Gypsum Valley. These indicate a relatively shallow basement composed of rocks of contrasting magnetic susceptibility and no distinctive structural trend southwest of Disappointment syncline and a more uniform and considerably deeper basement northeast to the Uncompahgre Plateau. A major fault or downwarp appears to occur along Gypsum Valley, and this may be a structural feature almost comparable in size to the uplift of the Uncompahgre Plateau. In contrast, only a small anomaly occurs over Paradox Valley; this may be caused by a basement ridge but is more likely associated with compositional contrasts. The increasing intensities toward the Uncompahgre Plateau are attributed to increasing susceptibilities of basement rocks rather than to decreasing depths. The La Sal Mountains high is of course related to the monzonite intrusives; in fact the form and trend of the major magnetic feature conforms with the topography of the Mt. Waas-Mt. Tomasaki igneous mass. A negative anomaly occurs over

Mt. Peale, resulting from inverse magnetization. The magnetic data indicate that the La Sal Mountains intrusive may be considerably larger than indicated by surface exposures; but it must be emphasized that it is impossible to distinguish between intrusive and basement rocks from magnetic evidence alone. One major feature, the Lisbon Valley-Dolores anticline, is not aligned with the magnetic trend indicating that the basement was not involved in the folding. A prominent local anomaly is found over the diorite stock in Castle Valley, northwest of the La Sal Mountains, and several small anomalies east of Klondike Ridge are likewise associated with igneous rocks. The igneous rocks of Klondike Ridge itself are not indicated because no magnetic traverse crossed them.

As already stated, the more prominent gravity anomalies in the Uravan area are related in most instances to changes in depth, thickness and facies of the Paradox salt formation. Negative anomalies as large as 30 mgals are found over the salt cores of Paradox, Gypsum, and Sinbad anticlines. A 1-mgal anomaly over the Dolores anticline indicates a small amount of squeezing and thickening of salt there also. A prominent gravity saddle in the Dry Creek Basin, between Paradox and Gypsum Valleys, is likewise attributed to upward movement of salt. Except over the northwest-trending salt valleys and along the Uncompahgre Front, the dominant gravity trend is northeast. This trend is normal to the regional structural trend and to the magnetic trend, and is apparently controlled by the salt as already described. The northwest trend along the Uncompahgre Front is obviously related to the upthrust dense crystalline rocks and is apparently the single major exception to the general rule that salt is the controlling factor.

Other features indicated by the gravity data are (1) decreasing salt northwest along the Dolores anticline toward Horse Range Mesa, and northwest and southeast from the gravity saddle in Dry Creek Basin, and (2) increasing salt southeast along Dolores anticline, and northwest and southeast from a broad gravity high at Club Mesa. Excepting the salt anticlines, the lowest gravity values are found near Nucla, indicating either a maximum thickness of salt or shallow depth to the uppermost salt close to the Uncompahgre Plateau. Based on high gravity values found elsewhere on the Uncompahgre Plateau, an extremely steep gravity gradient must exist between this salt basin and the Uncompahgre, indicative of an abrupt transition from salt to denser material due perhaps to both facies changing and faulting.

The gravity high at Club Mesa coincides in part with a magnetic high. It may be related in part to a basement high, but is probably caused in part by facies changes or withdrawal of salt. A broad gravity and magnetic low may also indicate a basement low or density contrasts within the basement.

Inter-River area. --A prominent gravimetric feature of the Inter-River area is a broad low bounded on the south by the Cane Creek anticline and on the northeast by the Courthouse syncline. This feature is believed to coincide with the area of maximum thickness of salt in the underlying Paradox formation; in fact the lowest gravity values were found over the Moab salt anticline. A minor thickening of salt is also indicated along the Cane Creek anticline in the central part of the Inter-River area. The gravity low may also indicate a deeper basin of deposition, but no information on this is available at present.

Also of interest are several local gravity highs in the south part of the area including one over Upheaval Dome, and a similar high one mile northeast of Courthouse syncline in the northeast part of the area. A magnetic high was also found over Upheaval Dome, which is a structural dome, apparently underlain at shallow depth by a plug-like igneous intrusion. The other highs may also be related to igneous intrusions, but magnetic information and additional gravimetric information are required.

A gradient totalling over 40 mgals in 12 miles between the Upheaval Dome high and the low north of Cain Creek anticline is probably attributable in part to increasing depth to crystalline rocks north from Upheaval Dome as well as to increasing thickness of salt.

Plans

Aeromagnetic surveys of the remainder of the region included in this project will be flown in the fall of 1954 in the Henry Mountains-Hanksville area.

Preliminary regional gravity surveys will be completed in the Monument Valley area during June 1954. July and most of August will be devoted to fill-in surveys in the Uravan and Inter-River areas as indicated by the preliminary gravity maps; and September and October will be spent on a preliminary survey of the White Canyon-Elk Ridge areas, where preliminary multiplex maps are available. Subsequently, regional surveys will be started in the San Rafael Swell area and will continue as far into the winter as conditions permit.

Reduction of gravity data from Monument Valley will continue at a modest rate through the summer, with the aim of completing a preliminary Bouguer gravity map by early winter. If road and weather conditions permit, fill-in surveys will then be made in Monument Valley.

Original-state core studies
by G. E. Manger

Analyses, not yet completed, were made of the physical and chemical properties of cores of the blue-black low-oxidation uranium ore and adjacent country rock from 2 bore holes in the Bitter Creek area of the Uravan district, Colorado. Coring was done with oil-base mud and air as the drilling fluids.

Tests on the elastic constants of cores from the carnotite terrane of Long Park, Uravan district, Colorado, were continued. In order to investigate the possible relationships of ground-water movement to the occurrence of carnotite, tests on "ore-bearing" sandstone from Long Park are in progress to simulate ground-water flow under low gravity gradients under varying degrees of permeability and water saturation. Further chemical and spectrographic tests were made on interstitial or pore water of cores from the carnotite terrane of Long Park. Additional tests were made of the capillary or so-called "irreducible minimum" pore water content by the water-displaced-by-air method at 100 pounds per square inch displacing pressure. The relationship of pore water saturation to the occurrence of carnotite ore and poorly mineralized or barren ground was further investigated. The results are presented in tables 3, 4, and 5, and figures 5, 6, 7, and 8.

In the original-state core project in the Long Park area, Uravan district, Colorado, further studies have confirmed the previously reported direct relationship of radioactivity with poorer sorting of grains, smaller grain size, lesser permeability and greater pore-water content in the range from roughly .002 to more than .68 percent eU_3O_8 .

The highly (water) desaturated permeable sandstones, the usual excess of capillary water (water remaining in pores after saturation and ensuing desaturation by air under pressure) over water originally in the pores, the high concentration of soluble solids assigned to the original pore water, and the low concentration of soluble solids in water flowing from springs indicate that soluble salts have been precipitated by evaporation from ground water entering the "ore-bearing" sandstone mainly by capillary attraction, but possibly also by some slow gravity flow, particularly in and below the ore zone in drill hole LP-530, (fig. 6).

Further analyses of pore water when compared with analyses of ground water confirm, in both waters, a high concentration of bicarbonate and notably lower concentration of sulfate and chloride, and also show that pore water contains relatively more potassium, relatively less magnesium, and some carbonate, and is higher in pH.

The permeable sandstone immediately above the carnotite ore zone in drill hole LP-530 and above the correlated position of this zone in the poorly mineralized drill hole LP-531 is greatly desaturated. This desaturated condition persists in permeable sandstone immediately below the correlated position of the ore zone in drill hole LP-531, but in drill hole LP-530 pore water saturation in permeable sandstone below the ore is appreciable, on the order of 25 percent.

"Normal" electrode configuration with 8-inch, 16-inch and 24-inch spacing seems capable of distinguishing adequately the high resistivity of the low-saturated permeable sandstone in essentially barren ground from the lower resistivity of the moderately saturated permeable sandstone below the ore in ore ground. However, in mineralized ground below

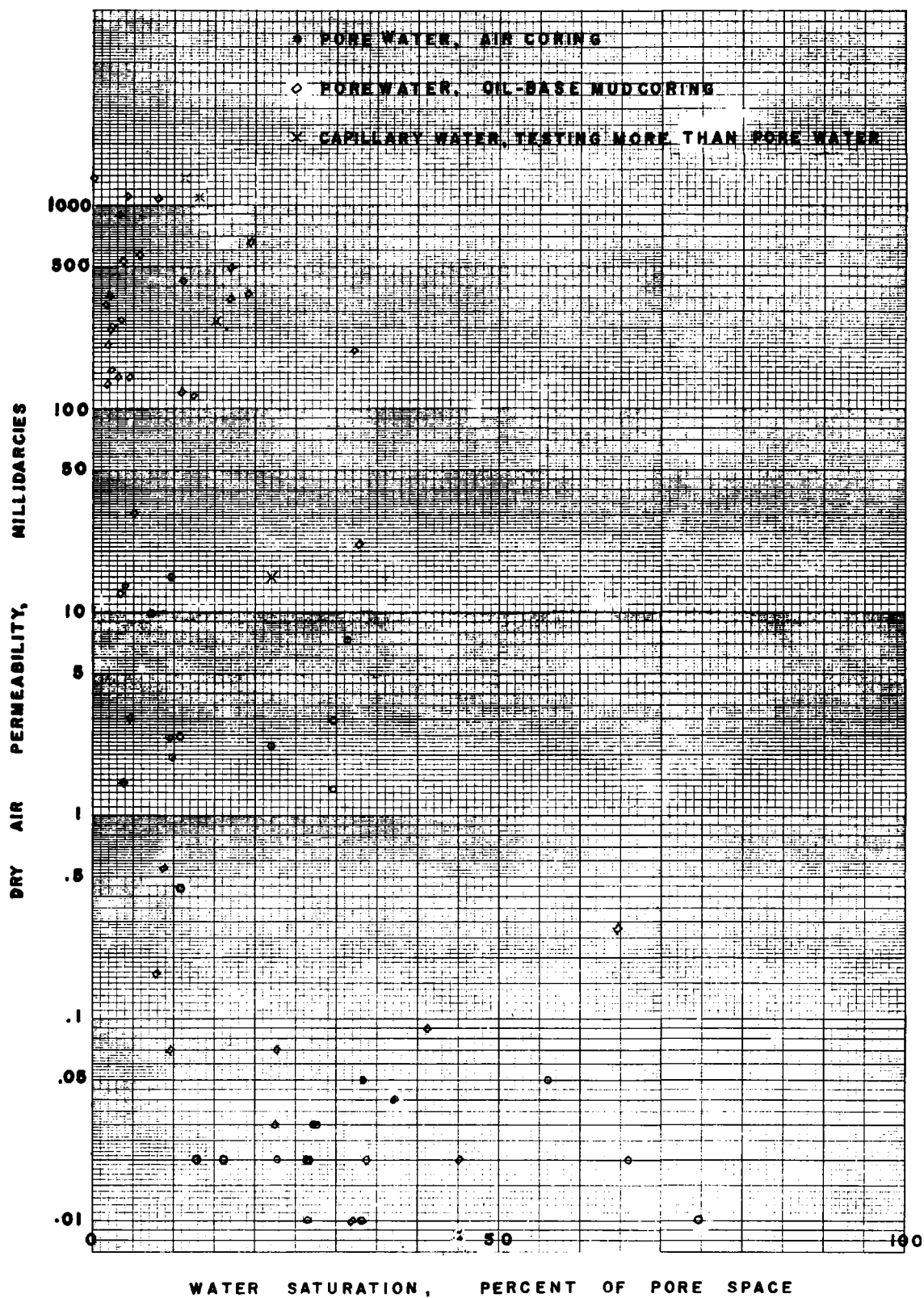

FIG. 5--DRILL HOLE LP-530, PERMEABILITY VS. WATER SATURATION, 76 FEET ABOVE TO TOP OF ORE ZONE.

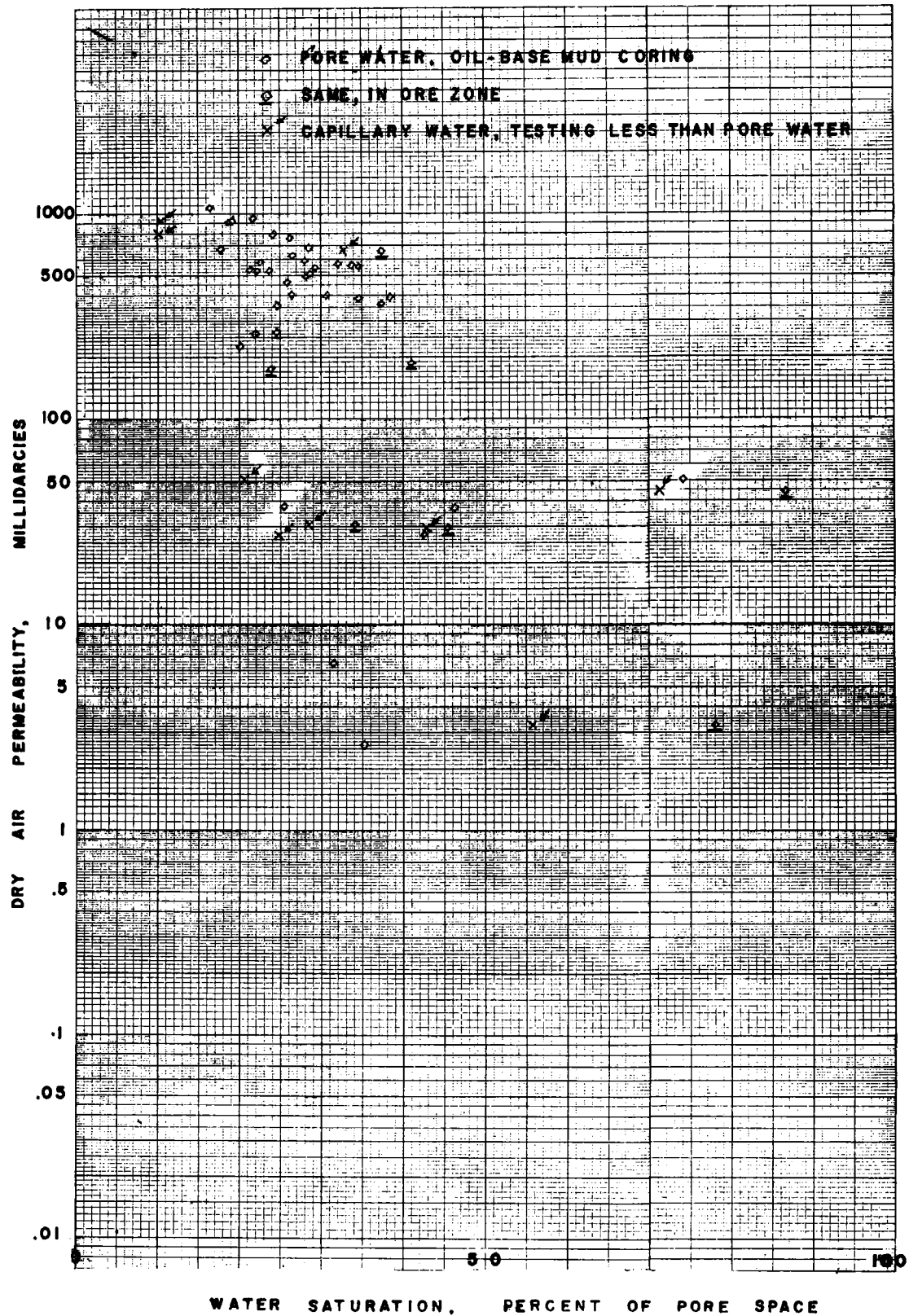

FIG. 6--DRILL HOLE LP-530, PERMEABILITY VS. WATER SATURATION, ORE ZONE TO 34 FEET BELOW.

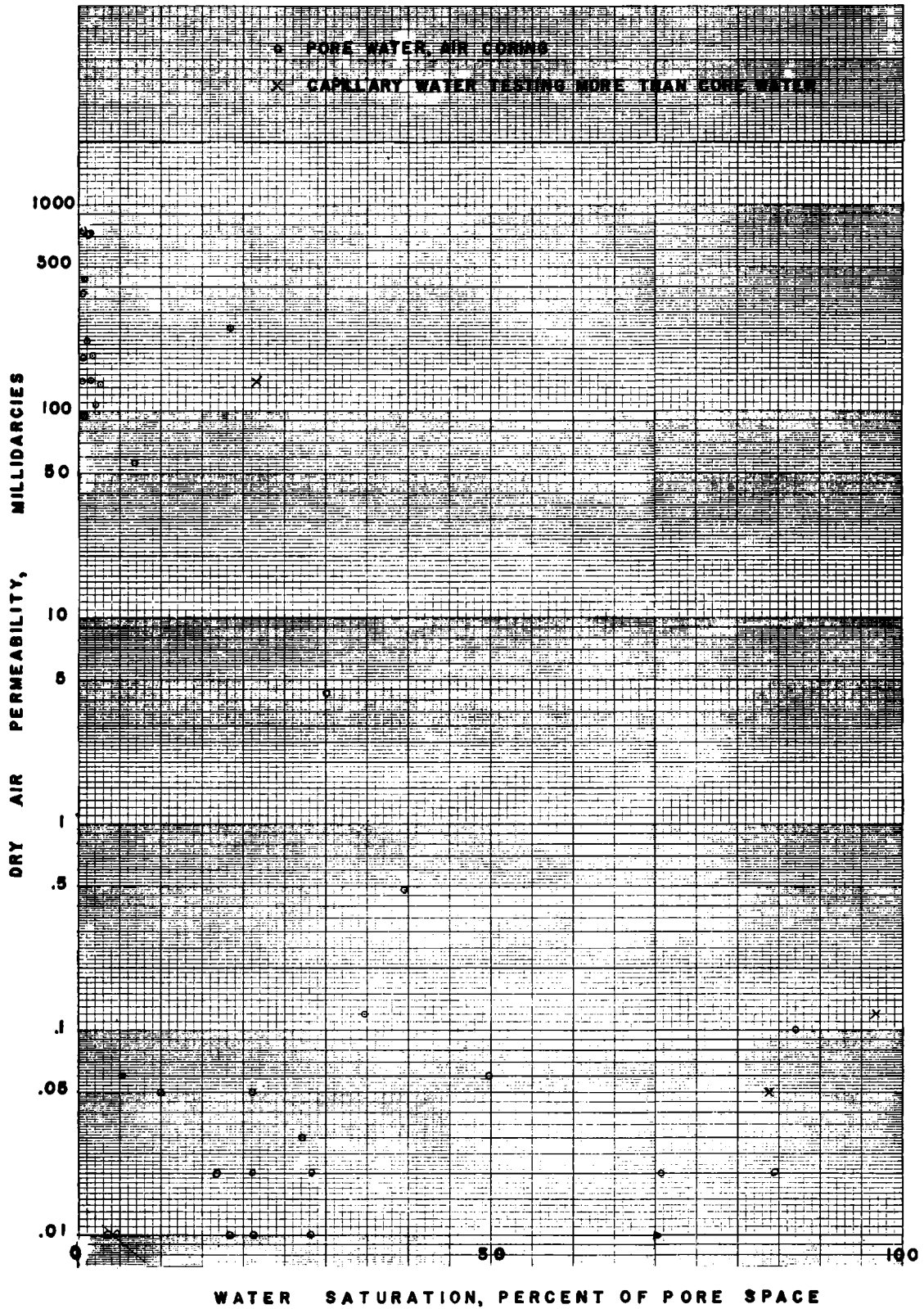

FIG. 7--DRILL HOLE IP-531, PERMEABILITY VS. WATER SATURATION, 60 FEET ABOVE TO TOP OF MINERALIZED ZONE.

Table 3.--Core properties near correlated ore-zone level showing weak radioactivity, Drill hole LP 531

Sample interval ^{1/} Depth from surface, feet	No. of samples	Water content, percent of pore space		Porosity, percent of bulk volume	Permeability, dry air, millidarcies	Radioactivity, ^{3/} counts per minute above background. (b = background)
		Originally in core	Capillary test ^{2/}			
<u>Cored with air: Entire section</u>						
195.20-203.82	10	18.9-87.5		6.80-14.6	0-.02	Not determined
203.82-204.72 (top)	1	62.3		16.7	0	413 ± 35
203.82-204.72 (middle)	1	57.1		17.6	0	358 ± 39
203.82-204.72 (bottom)	1					336 ± 33
(Gamma-ray bore-hole log shows .01 percent eU ₃ O ₈ in the interval from 202.7 to 204.1 feet.)						
204.72-205.49	1	26.3		21.0	0	Not determined
205.49-212.91	7	.2-1.4		10.3-20.5	95.7-747	" "
212.91-213.61	1	8.8		3.13	0	" "
213.61-214.34	1	18.4		1.99	253	" "
214.34-216.00	2	1.4-1.7		12.8-15.6	140-186	" "
216.00-216.95	1	.3	21.7	15.0	139	" "
216.95-222.64	7	2.0-9.1		2.74-13.5	0-135	" "
222.64-231.15	10	26.3-87.2		1.36-13.7	0-.10	" "
231.15-231.90	1	34.7	96.8	12.2	.12	" "
231.90-234.97	4	21.1-39.5		6.26-19.3	.01-.48	" "
234.97-235.81	1	10.0	83.9	9.87	.05	" "
235.81-237.37	2	12.2-14.3		9.28-12.6	.05-.11	" "
(Gamma-ray bore-hole log shows .013 percent eU ₃ O ₈ in the interval from 236.1 to 237.2 feet; probably equivalent of ore zone in drill hole LP 530.)						
237.37-239.08	2	1.9-2.0		18.6-20.0	113-143	" "
239.70-240.19	1	22.1	22.8	16.5	215	" "
240.19-240.86	1	13.6		19.9	212	" "
240.86-246.77	6	.8-2.0		18.0-26.1	110-761	" "
247.60-248.48	1	10.4		16.7	45.8	" "
248.48-250.84	3	1.9-6.8		16.7-18.1	92.7-176	" "
250.84-251.78	1	1.9	21.6	16.4	212	" "
251.78-257.79	5	1.9-4.5		13.8-17.6	75.3-778	" "
258.71-267.51	8	10.6-43.2		11.1-34.2	0-.18	" "
269.00-269.47	1	10.6		20.1	282	" "
269.47-270.05	1	20.1	13.9	18.3	318	" "
270.05-272.57	3	14.6-20.1		13.9-23.1	1.15-316	" "
272.57-274.78	3	1.9-4.8		12.2-14.2	.02-103	" "
274.78-275.28	1	10.4	47.5	14.9	29.8	" "
275.28-276.00	1	2.2		12.7	73.5	" "
276.00-276.80	1	6.9	35.9	18.9	116	" "
276.80-277.70	1	4.8		16.6	267	" "
277.70-278.70	-	21.1		1.39	58.9	" "
278.70-289.91	12	.6-5.0		15.6-22.3	56.6-443	" "
289.91-290.91	1	33.3	24.6	17.4	74.2	" "
290.91-291.49	1	17.2	66.6	17.2	14.5	" "

^{1/} Core recovery, using air as the circulating medium for the entire section was 93.4 percent.

^{2/} Refers to water-displaced-by-air value at 100 psi gauge displacing pressure, and with 3 percent sodium chloride solution as the saturating medium.

^{3/} Counts above instrumental background within the limits of standard deviation.

Table 4.—Core properties near ore zone, drill hole LP-530

Sample interval ^{1/} Depth from surface, feet	No. of samples	Water content, percent of pore space		Porosity, percent of bulk volume	Permeability, dry air millidarcies	Grain size		Radioactivity, ^{4/} counts per minute above background b = background
		Originally in core	Capillary test ^{2/}			Median mm	Phi ^{3/} standard deviation, (sorting factor)	
Cored with air: 200:00 to 233 feet								
227.90-228.90	1	9.8	22.0	15.1	15.0	.064	2.374	b
228.90-233.00	3	9.9-28.5		14.4-22.8	.03-2.47	.048-.098	1.851-2.043	b
Cored with oil-base-mud: 233.00 to 312.73 feet								
233.00-233.96	1	33.9		18.5	.02	.059	2.300	b
233.96-238.60	4	3.3-32.1		22.1-27.8	122-891	.107-.156	1.165-1.817	b
238.60-239.51	1	3.7		16.7	534	.184	1.272	46 ± 28
239.51-242.02	3	7.9-22.4		4.92-5.24	.03-.55	.136-.168	1.174-1.702	b
242.02-247.20	6	32.0-45.1		13.4-20.4	.01-.28	.003-.049	2.572-3.057	51 ± 29- 118 ± 30
247.20-248.18	1	4.6		15.3	3.05	.094	1.254	52 ± 28
(Gamma-ray bore-hole log shows .008 percent eU ₃ O ₈ in the interval from 243 to 250 feet.)								
249.16-250.16	1	5.1		20.8	30.9	.090	1.116	b
250.16-252.04	2	9.7-22.6		11.3-11.7	.07, .07	.086-.064	1.573-2.266	43 ± 28- 66 ± 29
252.04-253.00	1	3.3	15.1	22.0	270	.114	1.185	b
253.00-255.62	3	3.4-3.9		8.66-15.0	1.46-13.7	.118-.152	.969-1.035	b
255.62-262.04	6	1.7-4.5		15.6-21.0	132-326	.136-.154	.850-1.393	b
262.04-263.00	1	9.4		19.1	2.41	.086	1.475	112 ± 30
(Gamma-ray bore-hole log shows .01 percent eU ₃ O ₈ in the interval from 261.5 to 262.5 feet.)								
263.00-266.48	4	5.8-12.4		20.6-23.5	117-1070	.126-.226	.931-1.455	b
266.48-267.42	1	32.9		16.7	21.9	.178	2.568	b
267.42-268.37	1	.3	11.3	23.6	1370	.194	1.072	b
268.37-269.30	1							46 ± 29
269.30-272.15	3	1.9-3.1		19.4-20.4	142-359	.120-.162	.890-1.108	b
272.15-273.00	1	4.2	13.1	20.6	1050	.204	.958	b
273.00-275.88	3	16.9-19.4		17.8-21.4	347-643	.206-.245	1.019-1.442	b
274.93-275.88 bottom	1							109 ± 28
275.88-276.73 top	1							107 ± 31
275.88-276.73 middle	1	41.0		20.2	189	.255	1.500	382 ± 34
275.88-276.73 bottom	1	45.4	42.8	18.3	27.2	.262	1.539	590 ± 36
276.73-277.66 top	1	34.1	28.5	15.5	30.4	.200	1.249	1,928 ± 52
276.73-277.66 middle	1	78.1	55.7	15.3	3.27	.134	1.946	10,097 ± 104
276.73-277.66 bottom	1	86.6	71.3	21.9	44.5	.084	1.923	17,418 ± 132
277.66-278.46 top	1	37.4	32.7	20.8	660	.253	1.482	530 ± 25
277.66-278.46 middle	1	23.9		19.4	174	.196	1.068	494 ± 36
277.66-278.46 bottom	1	24.6		16.1	265	.227	1.007	63 ± 29
(Gamma-ray bore-hole log shows .68 percent eU ₃ O ₈ in the interval from 236.7 to 277.7 feet.)								
278.46-282.90	3	16.4-22.1		16.8-18.4	260-1070	.230-.277	1.020-1.282	Not determined
283.00-283.98	1	46.2		19.4	36.7	.146	2.042	" "
(Gamma-ray bore-hole log shows .004 percent eU ₃ O ₈ in the interval from 281 to 284 feet.)								
283.98-285.87	2	26.3-29.2		21.8-22.0	404-542	.152-.163	1.083-1.097	" "
285.87-286.79	1	24.1	11.1	23.1	796	.152	.973	" "
286.79-287.71	1	25.9		22.3	461	.139	1.006	" "
287.71-288.66	1	42.7	24.8	19.5	27.3	.118	1.140	" "
288.66-298.22	10	17.9-28.7		19.7-23.1	354-679	.157-.196	.986-1.172	" "
298.22-299.15	1	19.2	10.3	20.9	925	.199	.973	" "
299.15-307.66	8	22.0-34.7		19.0-22.7	362-952	.156-.200	.980-1.190	" "
307.66-308.50	1	74.2	20.6	21.4	50.9	.138	1.283	" "
308.50-312.73	5	25.5-38.4		6.19-21.7	2.61-762	.161-.227	.951-1.142	" "

^{1/} Core recovery using air as the circulating medium was 94.5 percent. Using oil-base mud the overall recovery was 99.5 percent, and 100 percent through the ore zone.

^{2/} Refers to water-displaced-by-air value at 100 psi gauge displacing pressure, and with 3 percent sodium chloride solution as the saturating medium.

^{3/} A measure of the spread of grain size distribution; the greater the deviation, the poorer the sorting.

^{4/} Counts above instrumental background within the limits of standard deviation.

ore grade, where the pore-water saturation in permeable sandstone may be expected to be intermediate between that in ore ground and barren ground, better resolution of the resistivity may be necessary than is possible with the electrode configurations now employed, particularly if the permeable intervals are thin. For example a configuration giving a laterally focused current may measure resistivity with sufficient resolution to obtain an indication of the direction to follow to reach ore ground.

Table 5.---Comparison of spring and pore water

Sample	Micro - equivalents								pH
	Na	K	Ca	Mg	HCO ₃	CO ₃	SO ₄	Cl	
4685 <u>1/</u>	.739	.082	3.094	2.714	4.013	-	1.602	.505	7.7
4686 <u>2/</u>	3.999	.222	2.495	5.509	6.962	-	4.370	.926	7.9
4687 <u>3/</u>	.826	.151	4.291	3.536	6.650	-	.895	.954	7.7
4688 <u>4/</u>	.869	.156	2.944	3.536	5.193	-	.999	1.038	7.7
85(middle) <u>5/</u>	1.304	.946	4.291	.905	5.569	.666	1.041	.281	8.7

- 1/ "Long Park, Long Park No. 10 mine, ore chute, ore-bearing sandstone." (Phoenix, TEI-161).
- 2/ "Long Park area, spring, base of ore-bearing sandstone". (Phoenix, TEI-161).
- 3/ "Long Park, Henry Clay mine, underground spring, mineralized sandstone." (Phoenix, TEI-161).
- 4/ "Long Park, Henry Clay mine sump, mineralized sandstone." (Phoenix, TEI-161).
- 5/ Water extract at 100°C from core of carnotite ore from drill hole LP-530 Long Park. Core sample showed 10, 097 ± 104 counts per minute above instrumental background, and 28,900 parts per million soluble solids assigned to pore water.

Powder River Basin, Wyoming
by W. N. Sharp, E. D. McKay, and Paul Soister

The reporting period was spent in compilation and correlation of data resulting from studies of the preceding summer's field work. Analysis of this work confirms tentative conclusions made in previous reports that (1) uranium deposits are associated with scour-and-fill or channel-fill sandstone beds, (2) a high carbonate content of the rocks is intimately associated with uranium or is the material replaced by uranium during mineralization, and (3) a broad northward-plunging anticline occurs in the area where some but not all uranium deposits are found. (See fig. 9.) Work on the paragenesis of uranium and associated minerals is recessed until suitable mine development is done behind weathered outcrops.

Geologic investigations planned for the 1954 field season include (1) additional geologic mapping to complete five 7½-minute quadrangles, (2) detailed examination of uranium deposits, and (3) preparation of a structure-contour map of the basin.

South Dakota

Black Hills
by G. B. Gott, R. S. Jones
E. V. Post, and W. A. Braddock

Geologic investigations

Within the area in which detailed mapping has been done, there appear to be several noteworthy relationships between the uranium-vanadium deposits and lithology, structure, certain types of iron stains, carbonate cement, and silicification. These relationships are briefly discussed below, but they should be further investigated to determine their value as possible aids in predicting ore.

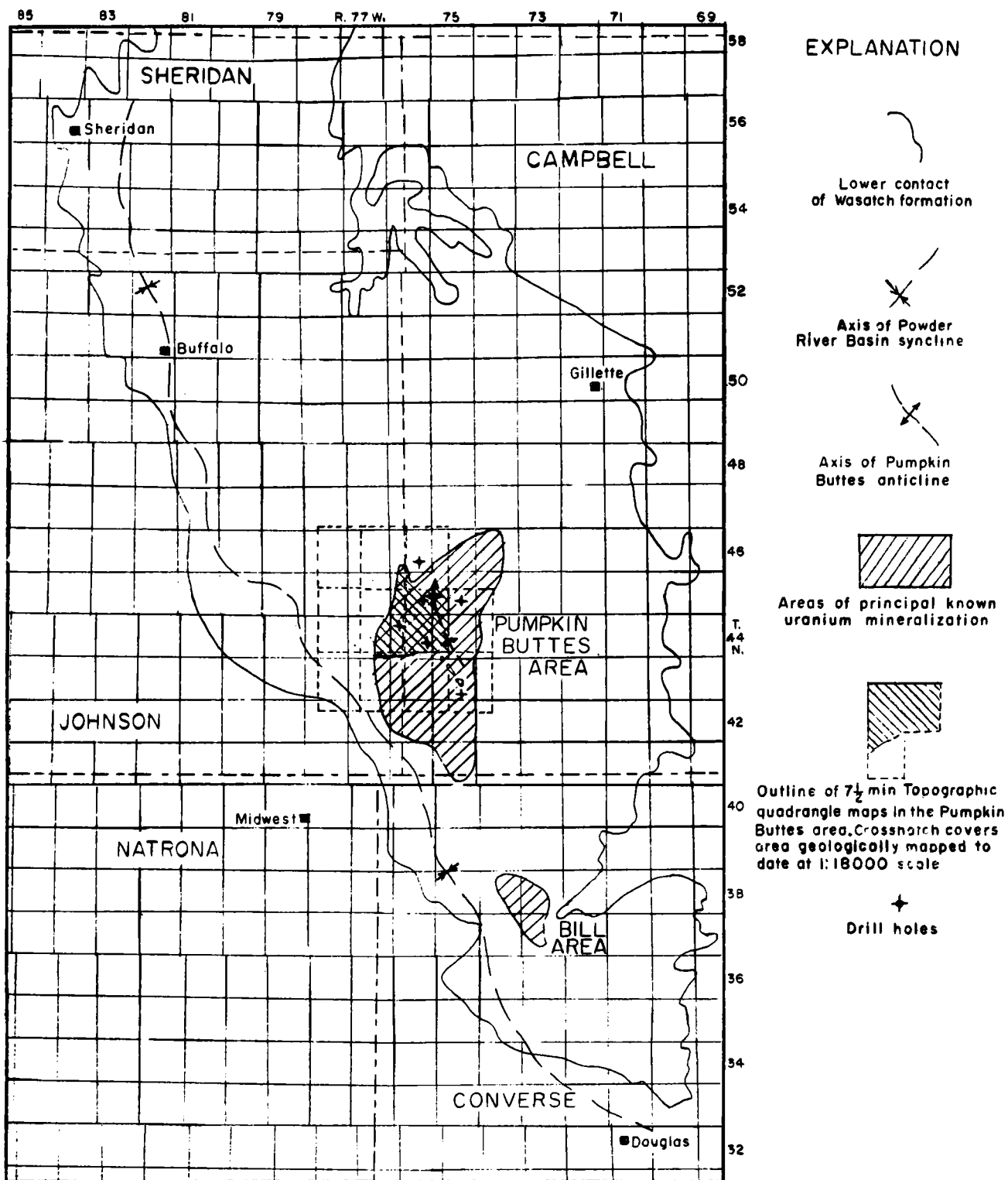

FIG. 9--GEOLOGIC MAP OF THE POWDER RIVER BASIN, WYOMING, SHOWING AREAS OF KNOWN URANIUM OCCURRENCES AND THE STATUS OF GEOLOGIC MAPPING.

Lithology.--From the distribution of the known deposits, it appears that the most favorable host-rock within the area mapped is the thickest sandstone in the lower part of the Lakota. Generally the deposits occur where the sandstone contains numerous mudstone "splits"--particularly the heterogeneous zone intermediate between floodplain and channel deposits.

The lower Lakota sandstone diminishes in thickness toward the east. It is not present at the mouth of Devil Canyon (sec. 4, T.9S., R.4E.), and is much thinner in the Parker Peak area than toward the west. The thinning of this sandstone toward the east generally coincides with the eastern boundary of the known deposits.

Structure.--The asymmetric southward-plunging Chilson anticline is the principal structural feature in this area. Its western limb is irregular. It dips steeply for a short distance, levels off to a relatively flat structural terrace about two miles wide, then forms a sharp monocline 1/2 to 3/4 mile wide that shows dips ranging from about $7\frac{1}{2}^{\circ}$ to 17° .

A structure map of this area (not included here) shows that a high percentage of the carnotite deposits occur in beds that dip less than 5 degrees. The deposits are most abundant on small anticlinal noses and along the upper margin of the monocline. The larger deposits such as the Holdup 15, the deposits worked by the Livingston Uranium Corporation, and those around Matias Peak, are structurally higher than the smaller deposits of the Red Canyon area.

A somewhat similar relationship exists between structure and the uranium deposits in the Fall River sandstone west of Craven Canyon. Figure 10 shows that the majority of the deposits are localized on a structural terrace crossed by a zone of faulting. In this area joints

and small flexures have affected the position and shape of the deposits. The majority of the deposits occur in sandstone less than 20 feet thick (fig. 10).

The distribution of the known deposits in relation to the structure suggests that it may be possible to predict areas that contain a high density of uranium deposits by using a structure map of an area that has a favorable sandstone-mudstone ratio.

Other phenomena bearing on mineralization.--A characteristic purplish-pink iron oxide stain impregnates the sandstones adjacent to many of the deposits. This color has been observed by most of the prospectors, miners, and geologists working in the area and appears to be one of the more useful guides to ore. Silicification and carbonate cement also are associated with mineralization in some places, although they are present also in some areas where uranium and vanadium minerals are not known to exist. More study is needed of these alterations to evaluate them in relation to mineralization.

In Red Valley, north of the Inyan Kara exposures, numerous blocks of basal Sundance sandstone are enclosed by the older Separfish "Red beds." These blocks range from less than 1 foot to about 50 feet in long dimension. They appear to have collapsed from the normal position of the overlying Canyon Springs member as a result of the removal of soluble salts at depth. This amount of solution would undoubtedly alter the chemical composition of the groundwater. It is possible, therefore, that there is an indirect relationship between the solution of underlying rocks and the ore deposits.

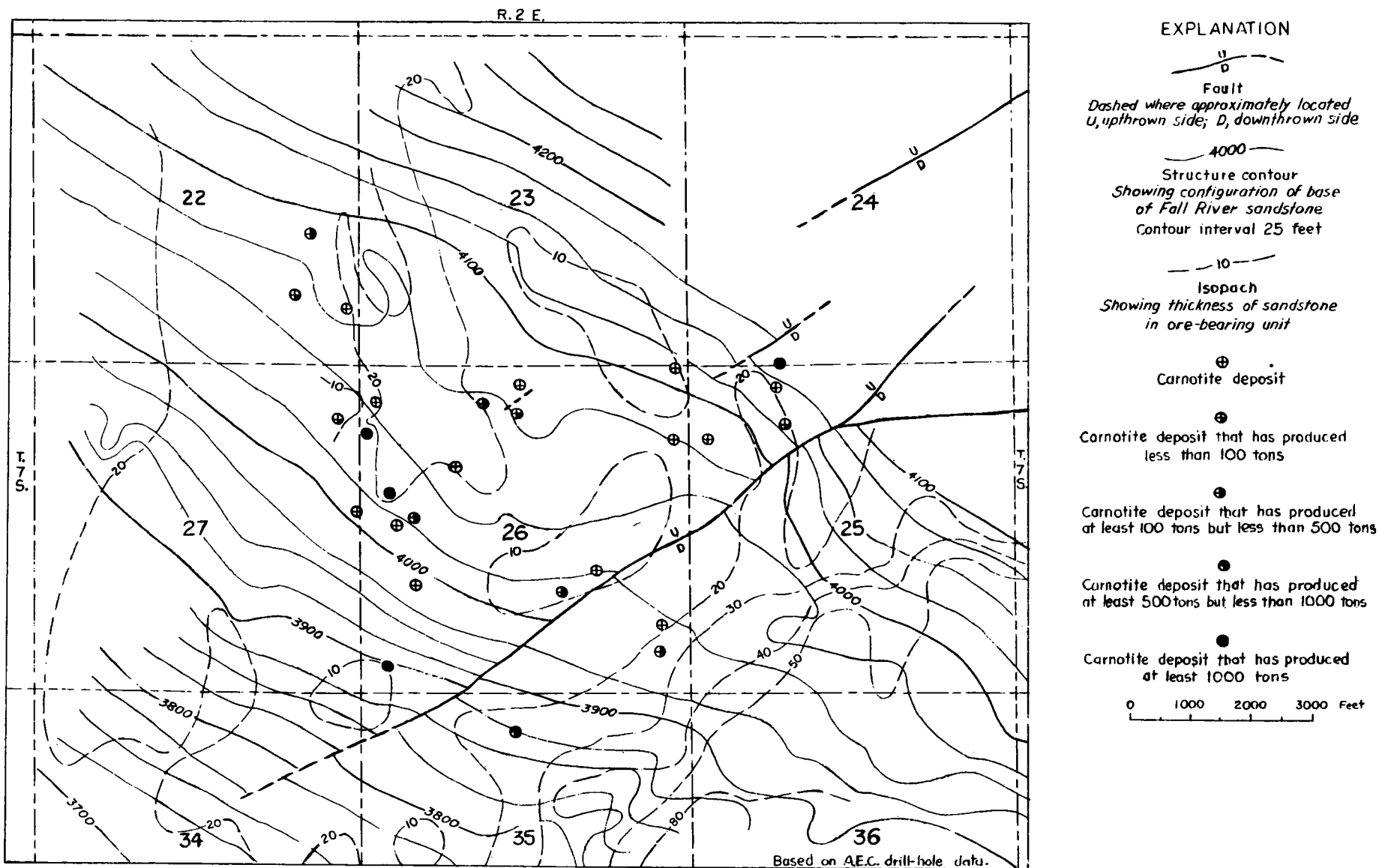

FIG. 10--RELATIONSHIP BETWEEN URANIUM DEPOSITS, STRUCTURE, AND STRATIGRAPHY IN PART OF THE EDMONT DISTRICT, FALL RIVER COUNTY, SOUTH DAKOTA.

Geochemical and geobotanical investigations

Chemical and spectrographic analyses of rock, soil, and plant samples continued.

The range of the available data follows:

Table 6.--Analyses of rocks, soils, and plant ashes from the Black Hills

Element	Rocks	Soils	Plant ashes
Fe	0.2 to 49.0 percent	0.3 to 7.3 percent	0.07 to 3.4 percent*
Mn	< .1 to 10.0 percent	< .001 to 1.5 percent	.007 to .34 percent*
V _e	< .03 to 2 † percent	< .03 to .5 percent	< .002 to .07 percent*
As	< 10 to 3000 ppm	< 10 to 150 ppm	
Zn	< 10 to 250 ppm	< 10 to 130 ppm	< 16 to 1600 ppm*
Cu	< 10 to 300 ppm.	< 10 to 150 ppm	70 to 340 ppm*
Pb	< 10 to 50 ppm	< 10 to 50 ppm	< 16 to 340 ppm*
Mo	< 1 to 20 ppm	8 to 26 ppm	20 to 120 ppm
Se	< 2 to 10 ppm	< 2 to 20 ppm	
U	< 1 to 10000 ppm	0.4 to 175 ppm	0.1 to 580 ppm

*Spectrographic values reported as the midpoint of the interval and converted to ppm for purposes of comparison.

Several analyses were made from soils taken beneath and near plants that were also analyzed for their uranium content. The amount of uranium in these soils and in the plant ashes do not differ. Chemical analysis for uranium in soils is a useful guide for locating uraniferous deposits as indicated in fig. 11. The anomaly in this figure is based on soils containing 3 to 8.4 ppm uranium and agrees well with the scintillometer-determined anomaly and less well with the laboratory equivalent-uranium anomaly.

The geochemical relationships of uranium with vanadium, manganese, iron, zinc, arsenic, and copper have been investigated. Over 200 samples from the Lion Nos. 1, 2, and 4 claims have been analyzed. The data are

divided into five categories: "mineralized" rock (MR), barren rock (BR), rocks from joint faces (RJ), soils from among joints (SJ), and soils (S). Mineralized rocks are presumed to be rocks with 0.01 percent or more uranium. The "rocks from joints" is rock chipped from brown to blue-black joint faces and contains an appreciable amount of underlying sandstone or mudstone. The median values of the data for these elements are as follows:

Table 7.--Geochemical relationships of rocks and soils, Black Hills

Rank	Percent			Parts per million		
	V	Mn	Fe	Zn	As	Cu
1	MR - 0.18	RJ - 0.61	MR - 1.9	MR - 55	S - 39	MR - 14
2	S - .14	MR - .32	S - 1.7	S - 45	MR - 20	S - 13
3	RJ - .12	SJ - .21	BR - .8	BR - <20	RJ - 19	RJ - 11
4	SJ - .06	BR - .06	SJ - .7	SJ - <20	SJ - 15	SJ - 10
5	BR - .06	S - .05	RJ - .6	RJ - <20	BR - 13	BR - 9

Copper and arsenic show little variation in most of the categories and evidently have little usefulness in prospecting for uranium in this area. Manganese--unlike iron, vanadium, and zinc--has the highest median values in joints and the lowest median values in soils. It does not appear to collect in the soil. It is probable that manganese anomalies could suggest a closeness to joints.

Iron, vanadium, and zinc have the highest median values in mineralized rock, with soils ranking second. An iron anomaly comparable to the uranium, equivalent uranium, and radioactivity anomalies is shown in fig. 11. The anomalies on this map represent about 20 percent of the investigated area. At the Road Hog No. 3A mine, one of the largest worked so far in the Southern Black Hills, the median value for iron in the overlying soil is 2.95 percent, which is much higher than the median values for iron from

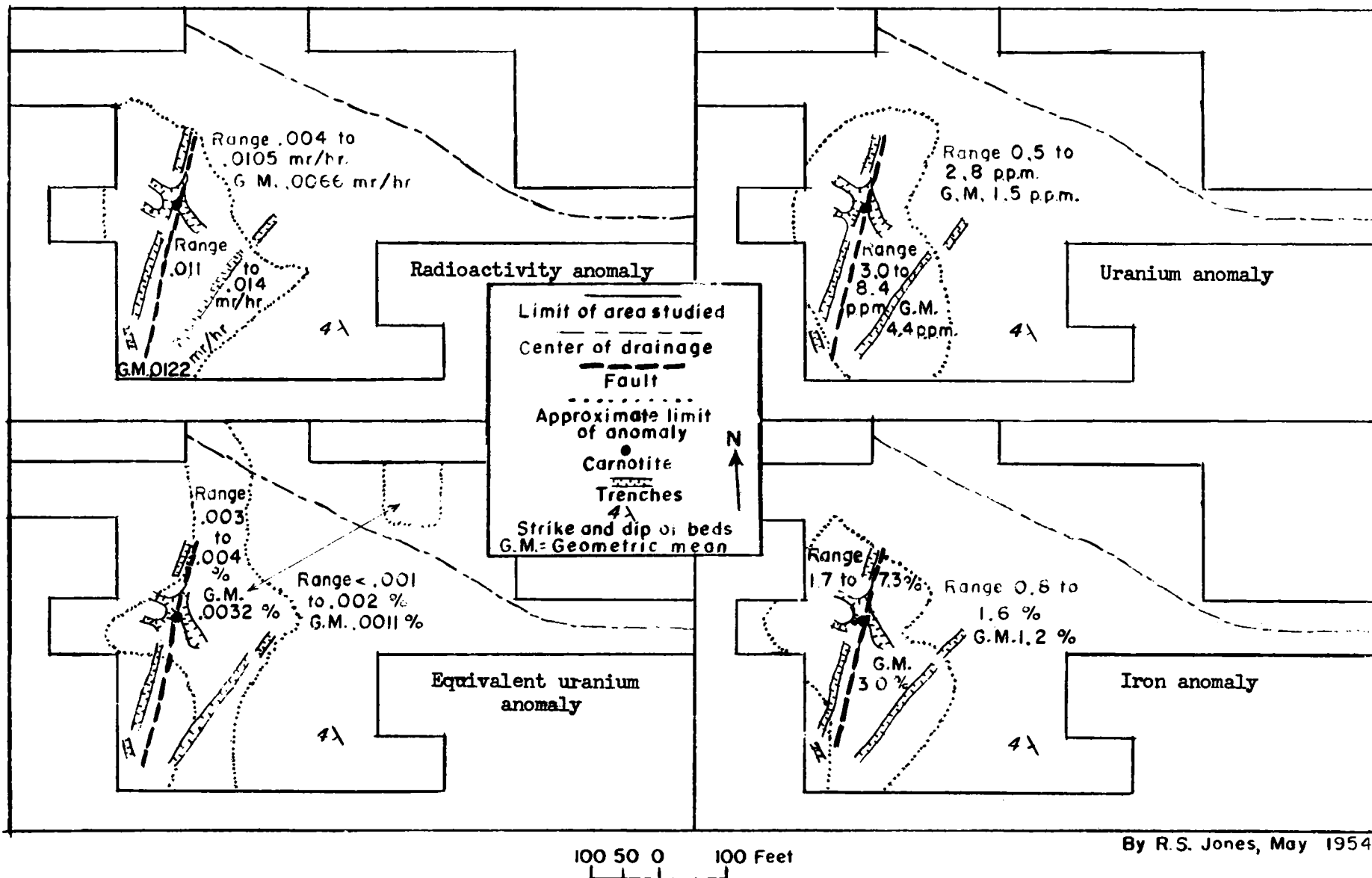

FIG. 11--SOME ANOMALIES AT THE LION NO. 4 TRENCHES, FALL RIVER COUNTY, SOUTH DAKOTA.

soils in other areas. In the soil above the Pabst No. 3 mine and above the uranium deposits between Sheep and Deadhorse Canyons, iron anomalies have been detected where vanadium, zinc, manganese, arsenic, and copper gave no anomalies.

Probably iron anomalies, used in conjunction with other anomalies, may prove to be useful in directing drilling operations to uranium ore deposits.

New Mexico

Guadalupita
by C. M. Tschanz

Field investigation of the copper-uranium deposits in the Sangre de Cristo formation near Guadalupita, New Mexico, was completed. Important conclusions of the investigations are as follows:

1. The principal uranium deposits are localized by sedimentary structures in stream-laid sandstone that overlies the members containing most of the copper deposits. The major copper deposits are in gray or black shale, limestone, or siltstone.

2. The most favorable position for uranium deposits is a sandstone member near the middle of the Sangre de Cristo formation. Particularly favorable are those parts characterized by local cut-and-fill structures, carbonized plant remains, chalcopyrite, gray or black clay galls, visible copper or vanadium minerals, and distinctive pink sandstones colored by hematitic alteration. Of these features, chalcopyrite, black clay galls, vanadium minerals and the distinctive pink tint are most closely associated with uranium.

3. Most of the uranium in sandstone is in a black ferric (?) oxide with red internal reflection. It gives no X-ray pattern. Metatyuyamnite is locally abundant. Generally, the uranium outcrops are inconspicuous and a counter is essential to prospecting.

URANIUM IN LIMESTONE

Miller Hill area, Carbon County, Wyoming
by J. D. Vine and G. E. Prichard

No significant developments have taken place since last season's field work in the Miller Hill area was completed.

Uranophane, $\text{Ca}(\text{UO}_2)_2\text{Si}_2\text{O}_7 \cdot 6\text{H}_2\text{O}$, occurs as vug fillings and along fractures in silicious, brecciated, freshwater limestone beds up to 10 feet thick in a sequence of Tertiary tuffaceous sandstone beds tentatively referred to as the Browns Park formation (?) of probable Miocene age. The distribution of uranium is erratic and there are no reserves of commercial interest. In test pits at points of high radioactivity on the surface of a limestone bed, the uranium content decreases rapidly below the top foot of limestone as indicated in the following typical analyses:

	percent eU	percent U
Top 12 in. limestone	0.040	0.025
Next 12 in. limestone	0.020	0.010
Bottom 30 in. limestone	0.007	0.008
<hr/>		
Total thickness 54 inches	0.017	0.012 weighted average

URANIUM IN VEINS, IGNEOUS ROCKS, AND RELATED DEPOSITS

District studies

Colorado Front Range
by P. K. Sims

Exploration

During the report period exploration for uranium was carried on by government agencies and private companies at the East Calhoun-Wood and German-Belcher mines, the Carroll mine, and the Golconda mine. (See fig. 12.) The exploration at the Cherokee mine has been recessed until electric power is installed. The projects at the East Calhoun-Wood and the German-Belcher mines were supported by DMEA; those at the Cherokee and Golconda mines were financed by AEC; and that at the Carroll mine by a private company. No ore was shipped during this period.

The exploration at the Carroll and Cherokee mines indicates the possibility of uranium ore bodies of economic importance; the work at the East Calhoun-Wood mine and the German mine indicates small quantities of high-grade ore. Because of the high cost of discovery, however, it is improbable that these mines will provide important production. Exploration at the Golconda mine has indicated that the sooty pitchblende in the shoot exposed on the Golconda No. 4 vein at tunnel level extends several feet below the level. Hard pitchblende, however, was not encountered in sinking of the winze.

The approximate outline of the known uranium ore at the Carroll mine is shown in figure 13. The ore appears to constitute a shoot that plunges at a fairly steep rate to the west. The stope length as exposed in

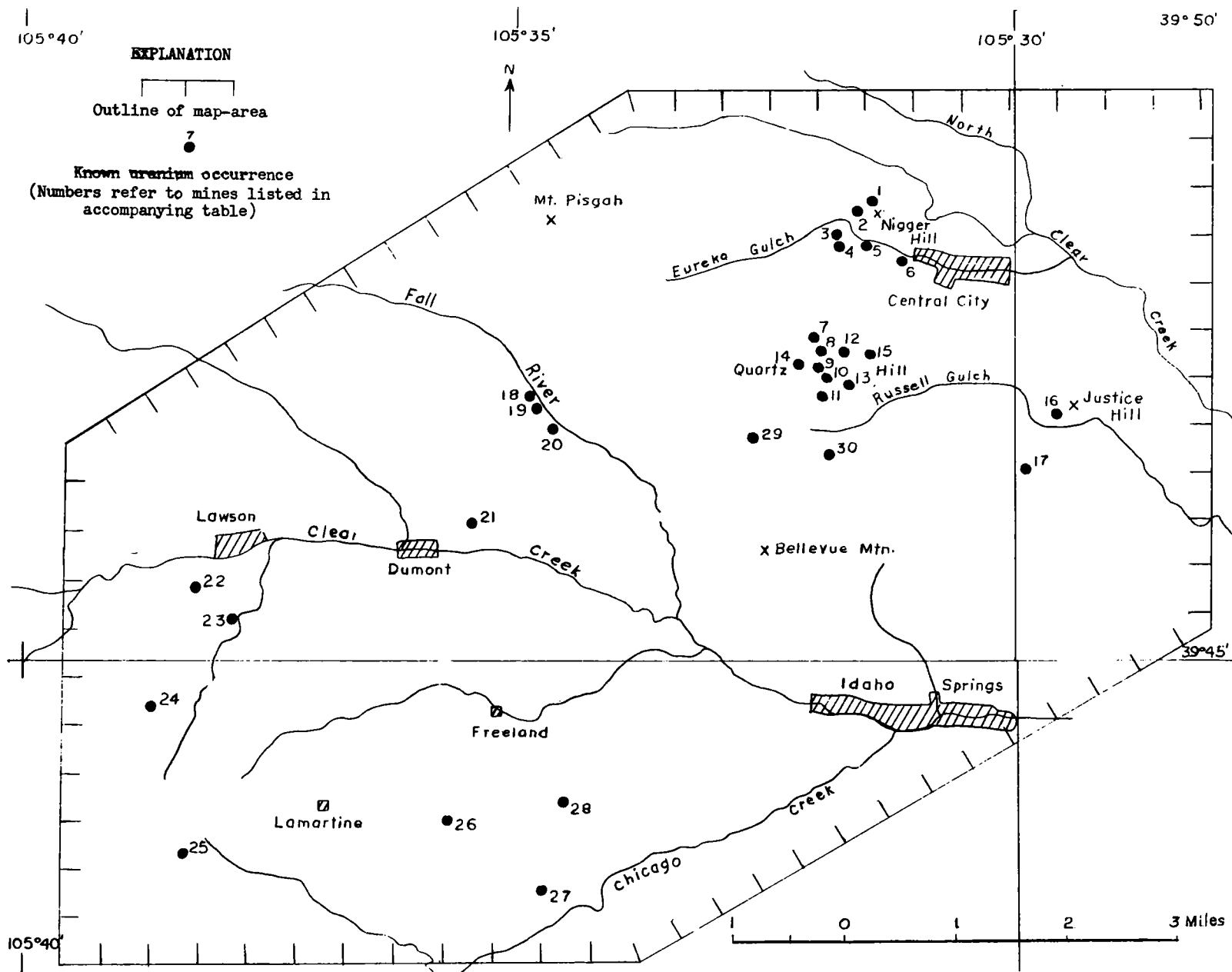

FIG. 12--PRINCIPAL KNOWN URANIUM DEPOSITS, CENTRAL CITY-IDAHO SPRINGS REGION, COLORADO.

← N. 78° W.

S. 78° E. →

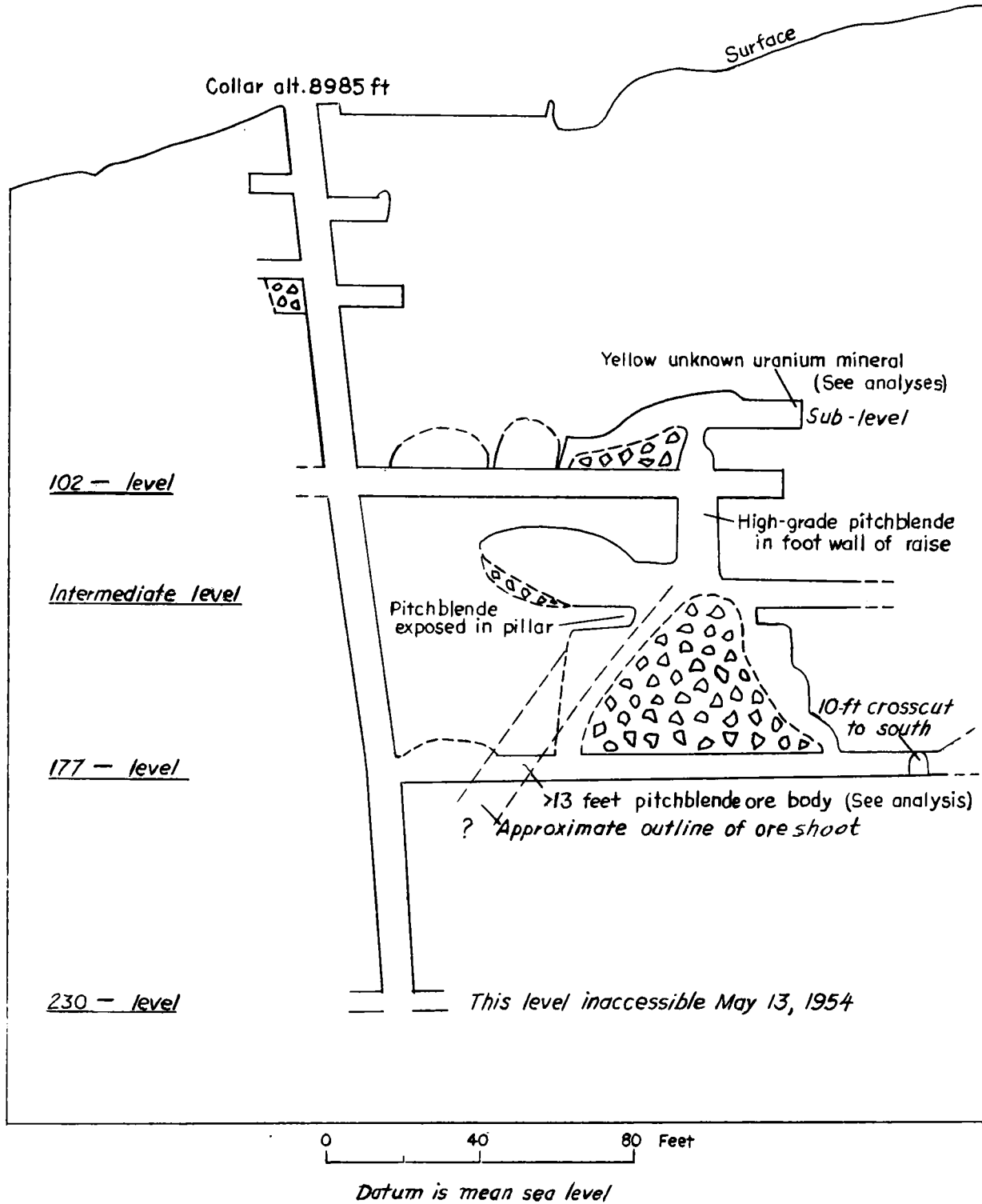

FIG. 13--VERTICAL LONGITUDINAL PROJECTION, CARROLL MINE, CENTRAL CITY DISTRICT, COLORADO.

a pillar on the 177-foot (second) level is 13 ft. or more; a comparable length is present in the stope above the level. The pitch-length of the shoot has not been determined. It is known that high-grade pitchblende occurs in the raise above the stope, just below the 102-foot (first) level, but as most of this ore is in the footwall of the inclined raise, the quantity is not yet known. The mapping and sampling completed to date indicate that the high-grade portion of the vein ranges from one to more than six inches in thickness. Channel samples across the vein, where exposed on the 177-foot level, are described below:

Table 8.--Data on samples from Carroll mine

<u>Sample number</u>	<u>Thickness (inches)</u>	<u>eU (percent)</u>	<u>U</u>	<u>Description</u>
C-S-E	2	.28	.36	Black pitchblende-bearing material.
C-S-F	7	.056	.11	Radioactive gray gouge in footwall of C-S-E.
C-S-G	6	2.8	3.04	Black ore.
C-S-H	7	.10	.23	Mostly gray gouge in footwall of black ore.

The pitchblende exposed in the raise just below the 102-foot level is hard; so far as known it is nowhere sooty. At places it is coated and veined (?) by green torbernite (?). In the sub-level above the first level, a hanging-wall vein exposed in a dog-hole contains an unidentified yellow uranium mineral and torbernite (?). Selected material from the vein analyzes 1.5 percent eU, 1.44 percent U, 15 ounces gold to the ton, and 165 ounces silver. The company plans further exploration of this vein which has not been encountered in lower workings.

Distribution of significant uranium deposits

The principal known uranium deposits within the region are shown on figure 12. Those mines that have yielded uranium in the past and those believed most likely, according to present data, to be new sources of uranium are indicated in table 9. Many other localities--dumps and mine workings--in the region are abnormally radioactive. Some of these localities are described in TEI-305; others will be discussed in a subsequent report after the completion of reconnaissance for radioactivity.

Mineralogy

The uranium in the Central City district occurs mainly as pitchblende. At the Two Sisters and R.H.D. mines metatorbernite, with minor kasolite, occurs in the upper oxidized portions of the veins. An unidentified yellow uranium mineral is present in the upper part of the Carroll mine; at lower levels the uranium occurs as pitchblende. In Fall River at the Golconda, Almaden, and Mary mines, uranium is present largely as sooty pitchblende; at places, however, hard pitchblende has been found. Aside from the occurrences at the Jo Reynolds and Bellevue-Hudson mines, the uranium south of Clear Creek is principally in torbernite, autunite, and sooty pitchblende. The principal known occurrences of colored uranium minerals and sooty pitchblende in the region are summarized in table 10.

Paragenesis of pitchblende-bearing veins

The sequence of deposition of the vein-forming minerals in the Wood vein, East Calhoun mine, is given in figure 14. Specimens from the Iron, Springdale (Gold Rock), and Kirk mines, examined under the reflecting microscope, show similar age and textural relations among the vein-forming minerals. The pitchblende in other veins--Cherokee, Flack, and Rara Avis--

Table 9.--List of mines containing significant uranium deposits,
Central City-Idaho Springs region, Colorado

Eureka Gulch area, Central City district

1. Two Sisters ^{2/} and R.H.D. mines
2. Carroll mine^{2/}
3. Bullion No. 2 mine
4. J. P. Whitney mine^{2/}
5. Rara Avis tunnel^{2/}
6. Buckley mine

Quartz Hill area, Central City district

7. Flack mine
8. German-Belcher mine^{1/}
9. Kirk^{1/} and Alps mines
10. Wood^{1/} and Calhoun mines
11. Leavenworth, Eldorado, and Bezant mines
12. Mitchell and Scandia mines
13. Harsh mine
14. Pyrinees mine
15. Bouvier mine

Justice Hill-Pleasant Valley area, Central City district

16. Bonanza mine
17. Cherokee mine^{2/}

Fall River region

18. Almaden (Blazing Star) mine ^{2/}
19. Golconda mine^{2/}
20. Mary tunnel^{2/}

Dumont area

21. Golden Calf and Albro mines

Lawson area

22. Bellevue-Hudson tunnel
23. Jo Reynolds mine^{1/ 2/}
24. Robineau claim^{2/}
25. Baltic tunnel

Alps Mountain area

26. Diamond Mountain mine
27. Orenaco (Golden Glen) mine
28. Martha E mine

Russell Gulch area, Central City district

29. Springdale (Gold Rock mine)
30. Iron, Pewabic, Old Town, and West Russell mines

^{1/} Mines have produced uranium.

^{2/} Mines that appear most promising as new sources of uranium.

Table 10.--Distribution of significant uranium minerals
Central City district, Colorado

Property	Type of sample ^{1/}	Occurrence
<u>Torbernite or metatorbernite</u>		
Martha E mine	U	Coating fractures and joints in migmatite; as disseminated flakes scattered through gouge of shear zone and altered wall rock. Predominantly found in footwall of shear zone.
Miller tunnel	U	Scattered flakes in gouge along vein.
Ariadne shaft	D	Thin coatings on fractures in biotite-muscovite granite.
Muscovite mine	D	Thin coatings on fractures in biotite-muscovite granite.
Humboldt mine	U	Scattered flakes in brecciated vein material and gouge.
Two Sisters mine	D	Replaces and veins altered biotite-quartz-plagioclase gneiss.
McKay shaft	U	Replaces altered amphibolite.
<u>Autunite</u>		
Martha E mine	U	With torbernite (see above).
<u>Sooty pitchblende ^{2/}</u>		
Martha E mine	U	Thin coatings along fractures parallel to shears in shear zone. Some along fractures cutting across shear zone but confined to it.
Humboldt mine	U	Thin coatings along fractures in brecciated sulfide ore and altered wall rock.
<u>Dumontite (?) ^{3/}</u>		
Ariadne shaft	D	Thin coatings along fractures in biotite-muscovite granite.
<u>Bayleyite</u>		
P. J. mine	U	Coats on abnormally radioactive pegmatite.
<u>Zippeite</u>		
Diamond Joe mine	U	Coats wall rocks, at and near bostonite.
<u>Metatyuyamunite (?) ^{2/}</u>		
Diamond Joe mine	U	Coats wall rock, at and near bostonite.
<u>Kasolite</u>		
Two Sisters mine	D	Coats vugs in altered wall rock and limonitic vein material.

^{1/} Dump sample, "D"; Underground sample, "U".

^{2/} Does not include deposits in Fall River, described elsewhere in this report.

^{3/} Identified by X-ray analysis.

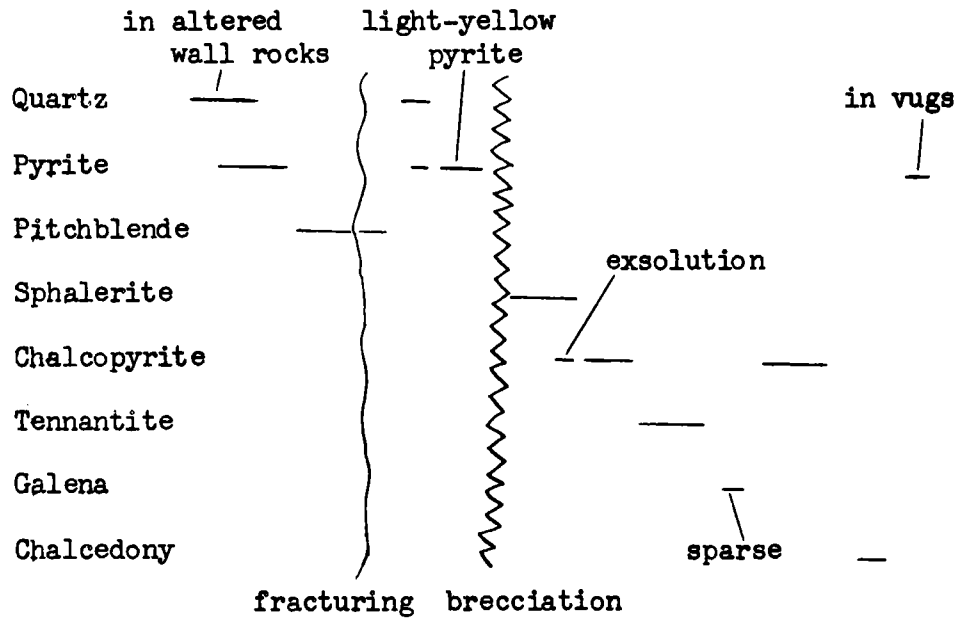

FIG. 14--PARAGENESIS OF VEIN-FORMING MINERALS, WOOD VEIN, EAST CALHOUN MINE, CENTRAL CITY DISTRICT, COLORADO.

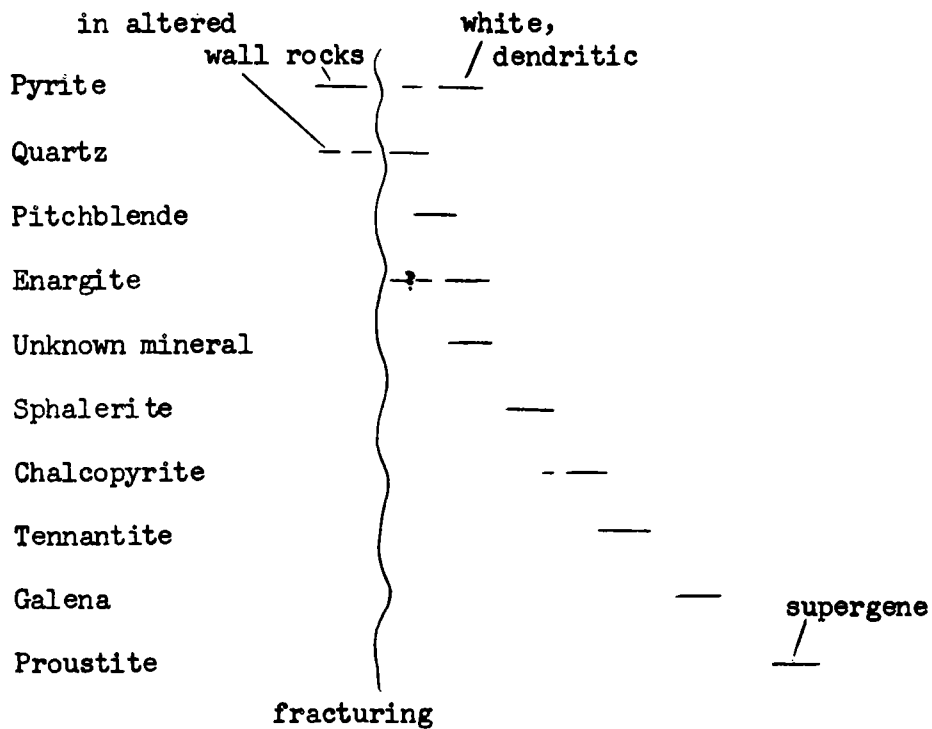

FIG. 15--TENTATIVE PARAGENESIS OF VEIN-FORMING MINERALS, ALMADEN MINE, FALL RIVER AREA, COLORADO.

in the Central City district likewise is very early in the sequence of deposition. Megascopic studies of the ore at the Carroll mine indicate that here too the pitchblende was deposited early, before the base metals. In these veins, pyrite is much less abundant and base-metals are much more abundant than in the Wood vein.

Study of polished sections of ores from the Central City district indicate that most of the pitchblende was deposited during a single generation, without a break in deposition although at places two generations were formed. In the Wood vein the first generation of pitchblende was deposited as colloform masses, mostly in open spaces. Following fracturing by movements along the vein, a second generation was deposited in the fractures with quartz and pale yellow pyrite. After deposition of the second generation of pitchblende strong movement along the vein brecciated all the earlier minerals; subsequently the base-metals were deposited. At the Cherokee mine, supergene (?) pitchblende with a colloform structure was formed locally and also supergene covellite.

The paragenesis of the ores from the Almaden mine in the Fall River district (based on 3 polished sections) is given tentatively in figure 15. The position of pitchblende in the sequence is similar to the Central City district.

At the Stanley mine (fig. 16), Idaho Springs district, the pitchblende, which so far as known is sparse, is later than both the quartz-pyrite and the base-metal mineralization. The pitchblende is hard and botryoidal and takes a good polish.

FIGURE 16 .--TENTATIVE PARAGENESIS OF PITCHBLENDE AND RELATED ORE MINERALS,
STANLEY MINE, IDAHO SPRINGS DISTRICT, COLORADO.

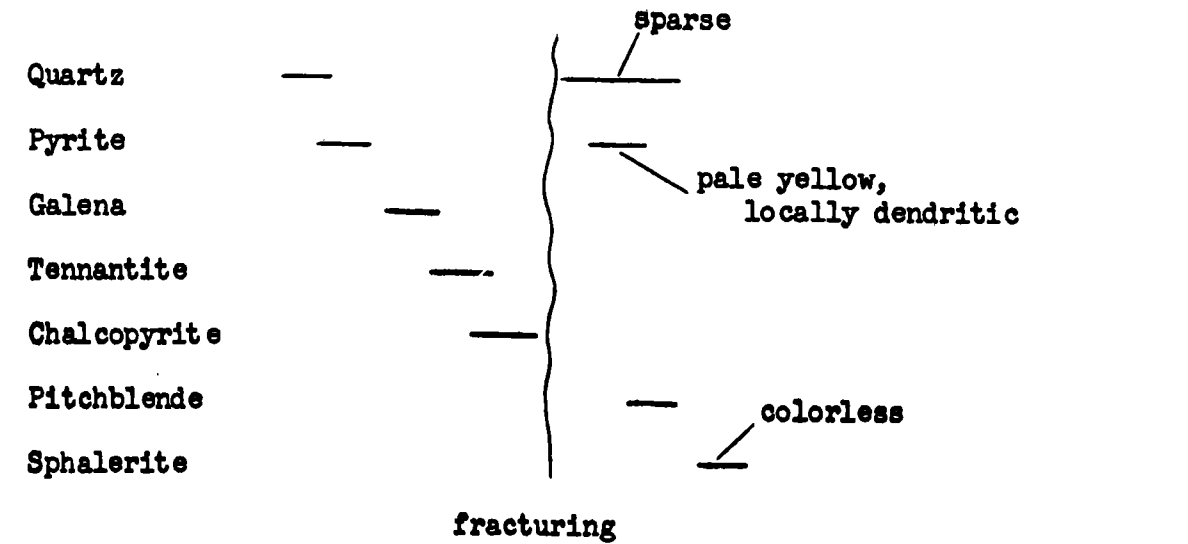

Relation of pitchblende to wall rocks

Wall rocks so far as known were not an important factor in the localization of pitchblende deposits in the Central City district. At the Golconda, Almaden, and Mary mines in Fall River, however, the pitchblende without exception occurs where the veins intersect garnet-quartz wall rocks. The occurrence of the ore adjacent to these wall rocks and the almost complete absence outside of this environment suggest that the uranium was localized by some chemical reaction between the wall rock and the ore-forming solutions. Further study of these rocks is being made.

Relation of metatorbernite to altered wall rocks in the Eureka Gulch area

The metatorbernite found on the Two Sisters mine dump and in the McKay shaft workings on Nigger Hill is in part of ore grade, and for the most part is disseminated through altered biotite-quartz-plagioclase gneiss and altered amphibolite, respectively. It replaces constituent minerals of the host rocks. At places it forms thin coatings on fractures in the rocks. Other rock types, and unaltered phases of the host rock types, do not contain metatorbernite.

The ore-bearing biotite-quartz-plagioclase gneiss at the Two Sisters mine has been altered largely to clay minerals. Two visual sub-zones of argillic alteration are recognized: (1) an intermediate zone with brown biotite and (2) an intense zone with bleached mica-clay. The intermediate argillic sub-zone contains biotite and quartz (original constituents of the gneiss) and an almost completely altered plagioclase feldspar, the latter component now a montmorillonite. With more intense alteration (closer to the vein), the biotite was bleached and subsequently altered to clay mineral aggregates. In the intense argillic alteration quartz is the only original component that remains. The sequence of alteration of the biotite-quartz-plagioclase gneiss apparently is as follows:

1. Intermediate argillic sub-zone

Plagioclase feldspar (An_{20-25}) altered to montmorillonite.

2. Intense argillic sub-zone

Biotite altered in part to illite (trioctahedral (?)) and/or sericite (used as a size term) and in part to chlorite, montmorillonite, and finally to kaolinite.

The alteration of the amphibolite on the McKay shaft workings may have proceeded similarly. Hornblende appears to be replaced by biotite in the soft crumbly rock of the intermediate zone of alteration. Plagioclase was converted largely to montmorillonite very early in the sequence, imparting a green color to the rock. The alteration of plagioclase appears to proceed at a more rapid rate than that of hornblende. In the most intense stage of alteration the rock becomes a soft green clay with occasional unoriented biotite flakes. The clay is composed primarily of montmorillonite with minor amounts of kaolinite, illite, and chlorite. The minor difference

between the intense argillic alteration of biotite-quartz-plagioclase gneiss and that of amphibolite is in the relative amounts of minor clay-mineral constituents in the green clay zone and the presence of less quartz in the amphibolite. In neither altered rock is there evidence of sericitization or silicification.

In the McKay shaft workings the metatorbernite is concentrated at the margins of the altered amphibolite pods and also is abundantly disseminated through the green clay. Samples of altered biotite-quartz-plagioclase gneiss from the Two Sisters mine dump show that the metatorbernite occurs as granules or aggregates of granules in the brown biotite sub-zone and as flake-shaped grains in the bleached mica-clay zone, at its contact with the brown biotite sub-zone.

Relation of uranium deposits to vein structure

Concentrations of uranium are known to be present along veins of several different trends. In the Central City district uranium minerals occur on 3 vein sets: (1) northeasterly-striking veins, as the Kirk and Calhoun, (2) easterly-striking veins, as the Wood and Iron, and (3) northwesterly-striking veins, as the Buckley and Carroll. In the Fall River region the principal veins known to contain 0.1 percent or more uranium strike northwesterly (Golconda, Mary, and Almaden) or easterly (Golden Calf and Albro).

Relation of carbonate-epidote alteration in Tertiary intrusive rocks to uranium mineralization

In the Tertiary intrusive rocks a characteristic carbonate-epidote alteration is associated geographically with known pitchblende-bearing veins. The alteration, noted in syenitic bostonite, quartz bostonite, monzonite, and

granodiorite, differs from the more widespread typical alteration of the dike rocks in barren areas. At a few places not known to contain uranium deposits, carbonate-epidote alteration was observed, and these areas will be checked for radioactivity to determine if this characteristic alteration is a useful guide to prospecting.

Origin of uranium minerals

Because of the close geographic association of uranium deposits with quartz bostonite bodies and the high zirconia content of each (Phair, TEI-247), it is thought that the uranium in the Central City district was derived from the differentiation of quartz bostonite magma. The source of the uranium in other areas still is uncertain.

The colored uranium minerals for the most part probably were formed by oxidation, solution, and transportation of uranium from primary pitchblende. Small quantities, however, could form through the leaching of uranium from radioactive porphyry dikes or radioactive pegmatites.

The origin of the sooty pitchblende is uncertain. The sooty pitchblende at the Golconda and Almaden mines is believed to be a product of the oxidation, hydration (?), and partial redistribution of hard pitchblende by descending waters. It has not moved far, however, because it still is closely associated spatially with the garnet-quartz host rock. Further studies are planned of radioactivity equilibrium and UO_2/UO_3 ratios.

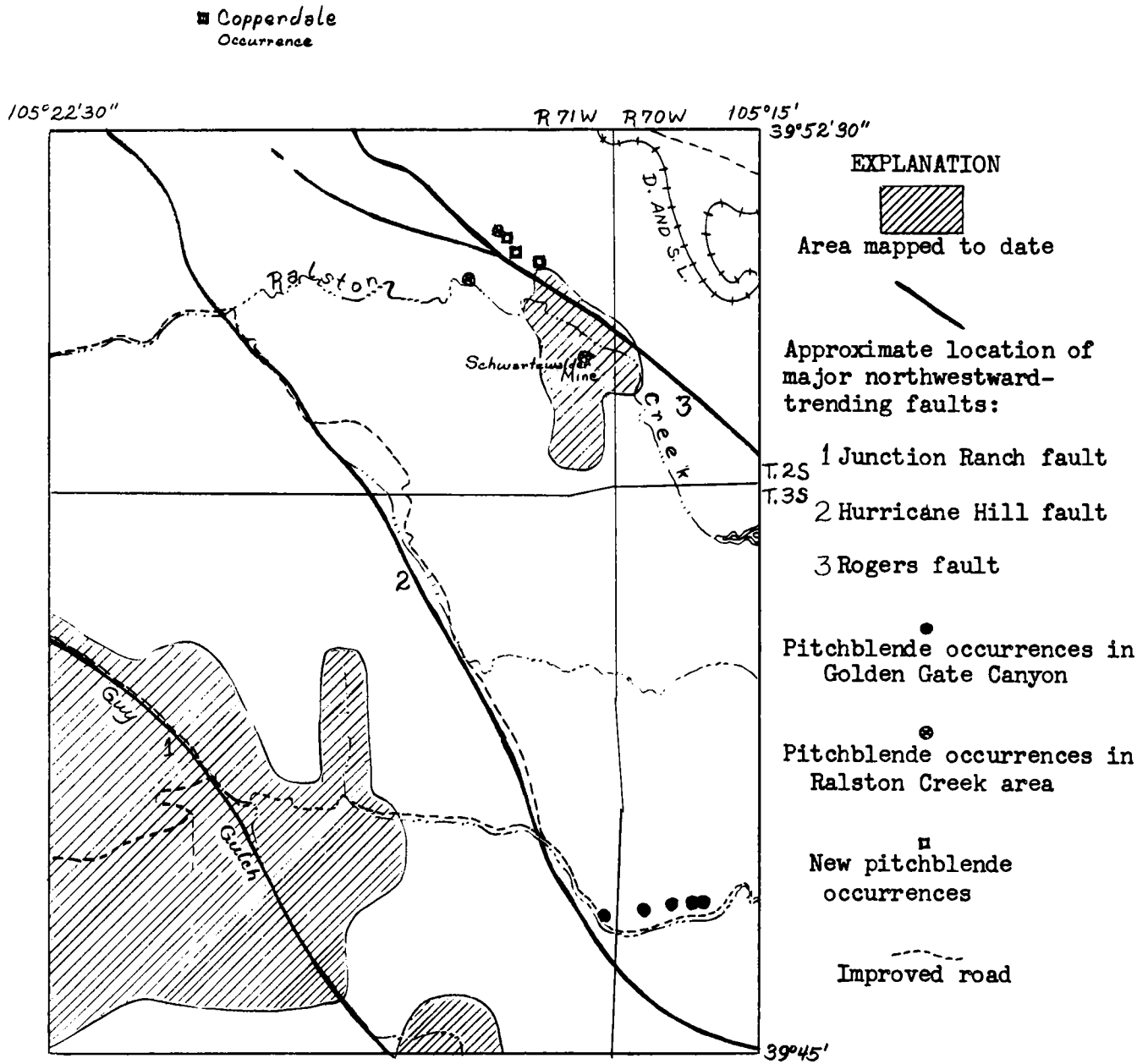

FIG. 17--INDEX MAP OF THE RALSTON BUTTES QUADRANGLE, JEFFERSON COUNTY, COLORADO.

Ralston Buttes district, Jefferson County, Colorado
by D. M. Sheridan and C. H. Maxwell

Most of the report period was devoted to preparation of a report on the Lost Creek schroeckingerite deposits in Sweetwater County, Wyoming, and to revision of back reports, critical review of referred manuscripts, and other office and administrative work. Under these conditions it was possible to spend only eight days in field work and approximately three weeks on laboratory, library, and office work related to the Ralston Buttes district study. Most of the field work was done at the Schwartzwalder (Ralston Creek) mine where underground mapping is being carried on by the personnel of this project assisted by J. W. Adams. The DMEA exploration program at the mine is still in progress and the mapping will be continued during the life of the Ralston Buttes project. Several shipments of pitchblende ore have been made from the property during the past seven months.

During the report period three new deposits of uraniferous material were discovered by prospectors in the Ralston Creek area (see fig. 17) and are reported on in the Reconnaissance section of this report (p. 173). A new uranium occurrence in the Copperdale district (fig. 17) was also investigated and is discussed in the Reconnaissance section.

Reconnaissance for radioactive minerals,
San Juan Mountains, Colorado
by C. T. Pierson

Field studies in 31 of the approximately 35 mining districts in the San Juan Mountains indicate only a small possibility of finding commercial uranium deposits in the region. Additional reconnaissance might disclose a few small commercial deposits, and it would be worthwhile for the mine operators to watch for pitchblende as a possible by-product.

Work during the reporting period consisted of report preparation and of laboratory study of the radioactive and non-radioactive specimens collected from the San Juan Mountains. The laboratory work included (1) microscopic studies, (2) selective sawing of hand specimens to obtain surfaces for binocular microscope and autoradiograph studies, (3) comparison of radioactive with non-radioactive specimens to determine whether any of the controls of pitchblende deposition were reflected by differences in the details of texture or mineralogy, (4) handpicking of megascopically visible uranium minerals for X-ray, spectrographic, microscopic, and age determination studies, and (5) preparation for grinding and mineral separation of the specimens in which the uranium mineral is finely disseminated.

The laboratory work indicated that (1) pitchblende is the most common uranium mineral in the San Juan specimens, although a fluorescent secondary (?) uranium mineral causes radioactivity in the pre-Cambrian slate near Ouray; (2) the pitchblende is late in the sequence of mineralization and occurs mainly as fracture coatings; (3) the principal sulfide minerals associated with the pitchblende are, in approximate order of abundance, galena, pyrite, sphalerite, enargite, and chalcopyrite; (4) the most common gangue minerals are quartz, barite, and clay minerals; and (5) no record of the control of pitchblende deposition was found in any of the specimens. This result was anticipated, however, because the controls probably were small variations in temperature, pressure, concentration, and chemical composition of wall rocks and ore-bearing solutions, which ordinarily leave no easily-read record.

Laboratory work contemplated includes (1) completion of the determinations of mineralogy and paragenesis, (2) study of the wall-rock alteration associated with the pitchblende vein in the Mickey Breen mine near Ouray,

(3) preparation and study of autoradiographs, and (4) separation and study of finely-disseminated uranium minerals.

Boulder Batholith, Montana
by G. E. Becraft

Petrographic studies of the quartz monzonite of the Jefferson City quadrangle, Mont. indicate that this quartz monzonite can be separated into about eighteen mappable units according to textural and modal differences that are apparent in hand specimens. The mineral deposits in the quadrangle have been separated into two major groups: (1) base-and-precious metal deposits commonly in major shear zones, and (2) chalcedonic vein zone deposits. Uranium is spatially associated with both types. The alteration is essentially the same in both types of deposits, and is strikingly similar to that at Butte. The four alteration zones present, from the vein outward, consist of silicification, sericitization, kaolinization, and an outermost zone of montmorillinite, which may extend a considerable distance from the vein.

Samples from the first three localities, described below, contain over 0.10 percent U. Locality no. 1 is the Argonne mine and is described in TEM-562.

Locality no. 2 is the lowest mine dump on the Bunker Hill vein. This vein has been mined sporadically during the past 60 years for lead, silver, gold, and zinc. The amount of ore shipped is not known but is believed to be small. Radioactivity has been detected on several dumps along the vein; however, only sample 53PR40a (table 11) contains an appreciable amount of uranium. No uranium minerals have been identified from this vein.

Table 11.--Analytical data on samples from the Boulder Batholith, Montana

Locality number	Locality			Sample number	eU percent	U percent	Sample description
	Sec.	T.	R.				
1	13	8N	5W	53PR35a	0.19	0.18	(Quartz and altered wall rock with visible secondary minerals.)
				53PR35b	.13	.12	
2	5	8N	5W	53PR40a	.26	.26	Altered wall rock with sulfide minerals.
				53PR40b	.032	.001	Altered wall rock.
3	4	6N	4W	53PR54	.17	.19	Iron oxide with uranium minerals.
4	6	8N	4W	53P260	.011	.007	
5	33	9N	4W	53PR15	.024	.017	
6	2	8N	4W	53PR23	.025	.063	Chalcedonic vein material.
7	4	8N	5W	53PR19a	.021	.017	Quartz vein with tourmaline.
				53PR19b	.033	.030	Vein with sulfide minerals.
8	34	9N	5W	53PR39	.083	.073	Altered wall rock.
9	10	8N	5W	53PR38	.061	.054	Quartz vein with pyrite.
10	31	9N	3W	53PR28	.028	.020	Chalcedonic vein material.
11	29	7N	5W	53CF39a	.052	.043	Vein with sulfide minerals.
				53CF39b	.065	.058	Vein with sulfide minerals.
12	20	7N	5W	53CF26	.035	.011	Vein with sulfide minerals.
13	16	8N	5W	53PR43	.035	.010	Vein with sulfide minerals.
14	21	8N	5W	53PR44	.086	.065	Vein with sulfide minerals.
15	22	8N	5W	53PR46a	.007	.001	Alaskite.
				53PR46b	.010	.005	Vein with sulfide minerals.
16	22	8N	5W	53PR47	.082	.028	Vein with sulfide minerals.
17	7	7N	4W	53P53a	.003	-	Mill tailings.
				53P53b	.018	.002	Vein with sulfide minerals.

Locality no. 3 is on the Mono claim on the eastern extension of the Comet-Gray Eagle vein zone. A green secondary uranium mineral, believed to be metatorbernite, has been identified from the dump of a shaft about 30 feet deep. The green mineral is associated with limonitic vein material. Radioactivity was also detected on other dumps along the vein on this claim.

Sample numbers, locations, and uranium and equivalent uranium contents of samples for which analyses are available are given in table 11.

Mineralogy and geochemistry
by George Phair and J. C. Antweiler

Results of laboratory work done during the report periods indicate that: (1) the optimum size of the sample taken into solution is 1 gram, (2) the 0.2 g and 50 mg samples previously used are definitely unsatisfactory and (3) the sodium carbonate fusion is more complete, faster, and more nearly fool-proof than the $\text{HF}+\text{HNO}_3$ fusion. Studies on related materials by F. S. Grimaldi and C. Sherwood in the Survey's Washington laboratory confirmed the first two conclusions.

A paper by Phair and Paul K. Sims on "The paragenesis and age of the uranium minerals in the Copper King mine, Larimer County, Colo." was read before the meeting of the Rocky Mountain Section of the GSA at Boulder May 8. Significant conclusions are: (1) the uranium ore consists of three black phases, namely uraninite, the new mineral "coffinite", and UO_3 -rich pitchblende; (2) field and micro-evidence indicate that the black uranium minerals are later than the associated "high-temperature" sulfides and magnetite; (3) helium age determinations by Prof. Hurley on three hand-picked samples of ore-magnetite and $\text{Pb}^{208}/\text{Th}^{232}$ ages on two monazites from pegmatites associated with the surrounding granite indicate that the latest

phases of intrusion and the earliest phase of ore deposition were late Pre-Cambrian in age and coincident within the limits of error of the measurements. These results substantiated field interpretation that the earlier massive sulfides plus magnetite were the result of pyrometasomatism related to the intrusion of the surrounding granite in which the first stage of replacement resulted in cummingtonite-anthophyllite-biotite skarn; (4) Good Pb^{206}/U^{238} and Pb^{207}/U^{235} age determinations corrected for common lead indicates a Laramide Age for the uraninite-"coffinite" ore, and show that two widely spaced and unrelated periods of ore deposition were represented in the single complex ore body; and (5) the UO_3 -rich pitchblende is amorphous to X-rays and almost certainly supergene. It lines leached cavities in the cavernous "boxwork" sulfide ores.

The first draft of a short manuscript by Phair and Henry Mela entitled "The isotopic composition of common lead in Front Range galenas and its geological significance" was prepared. Conclusions are:

(1) Five galenas from the southwestern half of the Laramide mineral belt are enriched in Pb^{206} , Pb^{207} , and Pb^{208} over the two galenas from the northwestern half. Midway between, two galenas from the Central City district have intermediate characteristics.

(2) Three galenas from "high temperature" deposits of unknown age outside the Laramide mineral belt have lower to middle Pre-Cambrian characteristics.

(3) As might be expected, the composition of the lead from the Stove Mountain pegmatite (definite late Pre-Cambrian) is intermediate between the Laramide and the earlier Pre-Cambrian leads.

(4) Unlike common leads from the Colorado Plateau which are generally deficient in Pb^{208} , thorium lead increases along with the uranium lead in most Laramide samples from the Front Range.

This work was undertaken to fill a regional gap in broader studies in isotope geology and to find out whether the Pb^{206} and Pb^{207} content of common leads were higher, in galenas from veins associated with radioactive porphyry intrusives and/or pitchblende deposits of similar age. The results were inconclusive. Any such local effect is obscured by the broad geographic variation already described.

General geologic studies

Zonal relations of uranium deposits in metalliferous districts
by S. R. Wallace and R. H. Campbell

Project personnel are preparing a report that will include the results of the zoning investigations since the spring of 1952, which will be ready for preliminary review by June 1, 1954. A report by R. H. Campbell on the results of radioactivity reconnaissance in the Gold Hill district in 1953 will be ready for preliminary review by the same date.

Studies thus far have been confined to districts of the Colorado Front Range mineral belt. Results indicate that in most of the districts investigated that show a zonal distribution of metals, the uranium tends to be concentrated in the transition zones between central areas of pyritic gold deposits and peripheral areas of lead-zinc-silver deposits.

Some additional reconnaissance will be made in the Gold Hill district in May and June to determine whether there is a concentration of radioactive localities near breccia-reefs. The radioactivity of telluride veins in adjacent districts also will be tested.

Frequency distribution of uranium with relation
to enclosing rock type
by J. W. Adams

Study was continued of the paragenesis and possible wall-rock control of certain pitchblende vein deposits in the Golden Gate Canyon and Ralston Creek areas in Jefferson County, Colo. (TEM-154 - USGS Circ. 320). Field work during the summer of 1953 confirmed that with the exception of the Buckman property the known uranium occurrences in Golden Gate Canyon are confined to beds of hornblende gneiss, and that most of the deposits are in a 100- to 150-foot thick bed of this rock that may be traced for at least 2 miles (TEI-390). The hornblende gneiss forms part of the Idaho Springs formation, a metamorphic complex of pre-Cambrian age.

The host rocks and ores of the areas were further studied during the past 6 months to determine the paragenesis of the pitchblende and associated minerals and to explain the localization of ore in the hornblende gneiss.

As the structural features of the hornblende gneiss are not markedly different from those of the adjacent biotite gneiss, the emplacement of the uranium and copper minerals appears to be controlled by (1) the north-trending Laramide faults or "breccia reefs", and (2) the composition of the rocks cut by these faults.

The Union Pacific prospect (USGS Circ. 320) in Golden Gate Canyon was selected for detailed study inasmuch as it afforded the best exposures of the contrasting wall rocks. At this deposit high-grade pitchblende ore occurs in hornblende gneiss along the hanging wall of an eastward-dipping breccia reef. No uranium minerals or significantly high radioactivity anomalies have been found along the reef outside of the hornblende gneiss bed, which is about 100 feet thick at the Union Pacific prospect.

Channel samples of the gneisses and breccia reefs were taken for spectrographic and chemical analyses. These samples were supplemented by thin and polished sections of the rocks and ores, study of which is now largely complete.

Available data tend to ascribe the "favorable" quality of the hornblende gneiss to its iron content, which is about twice that of the biotite gneiss. The quantity of iron, however, may not be as important as the form in which it is present. Thin and polished sections of the hornblende gneiss from a number of localities in Golden Gate Canyon show that at least part of the hornblende gneiss beds contain approximately 2 percent pyrrhotite; this is about twice the opaque mineral content of the biotite gneiss as indicated by available thin sections. In hornblende gneiss adjacent to the ore, the pyrrhotite is altered to hematite or an intergrowth of hematite and pyrite. Polished ore specimens show that these small but numerous hematite-pyrite intergrowths have been the nucleus for the deposition of some chalcopyrite and tennantite. It is believed that this "salting out" of a little copper from the ore-bearing solutions may have initiated the cycle of deposition.

The hornblende in the gneiss may also be an important factor in the localization of the ore, but its role is not as apparent as that of the pyrrhotite. Where the hornblende was available to ore solutions it has been completely bleached and altered to a fine-grained material believed to be carbonate; this alteration would be accompanied by a release of iron, a known precipitant of uranium.

The mineralogy and paragenesis of the pitchblende deposits in northern Jefferson County, Colo. are remarkably similar. In general, initial faulting was followed by introduction of solutions that reacted strongly with

the ferromagnesian minerals in the wall rocks to form carbonates and release iron. Much of the iron was redeposited as finely disseminated hematite. At the same time, the pyrrhotite in the gneiss was converted to the hematite-pyrite intergrowths. That the invading solutions were rich in potassium is indicated by the conversion of the wall rock plagioclase to orthoclase and the deposition of orthoclase (adularia?) crystals in fractures. Pitchblende appears to be the first ore mineral to be deposited in quantity, although it may have been preceded by a small amount of chalcopyrite as a replacement of earlier pyrite. The pitchblende was deposited directly on crystals of carbonate or the less abundant potash feldspar. Copper sulfides, notably tennantite and chalcopyrite, and lesser amounts of sphalerite and galena followed and partially replaced the pitchblende-carbonate vein filling. At the Union Pacific deposit, some of the ore was brecciated and invaded by additional carbonate. The inclusion of ore fragments in the upper part of the breccia reef at the Union Pacific shows that the final consolidation of the reef took place after ore deposition.

The influence of wall rocks on the localization of ore in the Ralston Creek area has not been studied in detail. However, recent observations at the Schwartzwalder (Ralston Creek) mine suggest that the emplacement of the pitchblende-bearing ore now being mined was the result of both favorable structural and host-rock conditions, the host rock in this case being a skarn-type rock containing garnet. Hornblende gneiss is associated with the pitchblende deposits at the Nigger Shaft and North Star properties.

Relationship of uranium and other trace elements
to Post-Cretaceous vulcanism
by R. R. Coats

The results of the spectrographic, fluorimetric, and radioactivity determinations on 117 volcanic rocks, nearly all of rhyolitic or dacitic composition, were studied with respect to the relationship between the content of uranium and that of boron, tin, beryllium, niobium, lanthanum, lead and zirconium, for those rocks for which results on all these elements were received, and with respect to the relationship between geographic distribution and content of the rare elements. The content of uranium has a significantly high positive correlation with that of niobium and beryllium, a lower but still significant correlation with lead and tin, and no significant correlation with boron and zirconium. A study of the relation of content of the several elements to the geographic provenance shows significant variation with provenance for all these elements, and on the basis of these variations and on patterns of consistency, five co-magmatic provinces, one of which is tentatively subdivided into three sub-provinces, have been delineated, in part, on a map of the western United States. The pattern of distribution of boron is significantly different from that of the other elements. The regional differences are believed to be a reflection, in large part, of the major structural features of the area investigated.

Analytical results for the uranium content of all the rocks thus far submitted, together with results for the uranium and fluorine content, have been received. Further work is planned in New Mexico, Texas, and Arizona, to make the regional coverage more nearly complete.

URANIUM IN CARBONACEOUS ROCKS

Coal and lignite

Eastern United States
By J. W. Huddle and E. D. Patterson

A total of 80 samples from 20 localities, collected mainly from the Freeport, Kittanning, and Pittsburgh coal beds in southwestern Pennsylvania, were taken. No field readings in excess of 0.001 percent eU were observed. These samples complete the reconnaissance in Pennsylvania.

A total of 175 samples from 50 localities in Indiana showed radioactivity of 0.001 percent eU or greater in three coal beds: an uncorrelated coal near Gentryville in Spencer County (TEI-34), the Minshall coal in Spencer County, and the top foot of the No. V coal in Warrick and Greene Counties. There are no appreciable reserves of the uncorrelated coal near Gentryville, nor in the Minshall coal in Spencer County (USGS Circ. 266, fig. 8), but the No. V coal bed is being mined in Warrick and Greene Counties and considerable reserves probably remain. The radioactive part of the coal, however, underlies only a small area.

A radioactive grayish-black shale containing brachiopods and other marine fossils forms the roof of the No. V coal. This shale averages 0.009 percent eU, ranging from 0.006 to 0.016 percent, in nine samples from widespread localities in Warrick, Pike, Vigo, and Vermillion Counties. The shale is 4 to 6 feet thick at most localities and is exposed in many strip mines.

In southeastern Illinois, an active coal mining area, 157 samples of coal and carbonaceous shale from rocks of Pennsylvanian age were collected at 27 localities. No radioactive coal beds were found. The grayish-black

shale forming the roof of the No. 5 coal, (a correlative of the No. V of Indiana), and the grayish-black shale above the No. 6 coal of Illinois are radioactive, but the amount of radioactivity is not yet determined. The grayish-black, hard, sheeted shale, containing marine fossils, above the No. 5 coal is widespread (GSA Spec. Paper 17, p. 15) in the Eastern Interior Coal Basin, but the grayish-black shale above the No. 6 coal grades laterally into light-gray shale which is probably non-radioactive (Illinois Bull. 78, p. 35).

The Eastern coal reconnaissance project will be discontinued July 1, 1954.

Southwestern Colorado and Northwestern New Mexico
by E. H. Baltz, Jr.

Only two of the samples collected in southwestern Colorado and northwestern New Mexico contain more than 0.005 percent U. A sample of bituminous shale and siltstone from the Paradox member of the Hermosa formation in sec. 33, T. 44 N., R. 16 W., San Miguel County, Colorado, contains 0.007 percent U. A sample of siltstone, sandstone, and shale collected from the Paradox member at the Bald Eagle prospect in sec. 24, T. 44 N., R. 17 W., San Miguel County, Colorado, contains 0.10 percent U. Here the band of mineralized rocks is at least 20 feet thick and 200 feet long.

Carbonaceous siltstone and sandstone of the middle member of the Chinle formation in the vicinity of Sabinoso, San Miguel County, northern New Mexico contain uranium deposits of possible commercial importance. A channel sample taken across 3.2 feet of carbonaceous siltstone and sandstone at the prospect of the Hunt Oil Company (sec. 30, T. 17 N., R. 24 E.) contains 0.22 percent U. A selected sample from the middle of the mineralized unit contains 0.88 percent U.

Further reconnaissance examination of carbonaceous rocks is planned in the northern and western parts of the San Juan Basin in New Mexico. The Percha shale in south-central New Mexico also will be examined.

Utah-New Mexico
By H. D. Zeller

Three major areas were investigated during the period: the Kaiparowits Plateau, the Henry Mountains, and Kolob Terrace. No uranium deposits of economic importance were found. In the Kaiparowits Plateau area a few 1- to 2-foot beds of carbonaceous shale in the Dakota (?) sandstone contain .006-.007 percent U.

The field estimates of radioactivity reported for this project in TEI-390 were higher than the laboratory determinations. This discrepancy was probably due to "fall out" of radioactivity which was extremely heavy over the examined areas during most of the period of the investigation.

Future plans involve reconnaissance of large areas on the High Plains of New Mexico and north Texas, the Sacramento Mountains, south-central New Mexico, and several small coal fields in McKinley and San Juan Counties, New Mexico.

North Dakota
By G. W. Moore

In the late fall of 1953 sampling and geologic mapping were carried on in the HT Butte, Chalky Butte, Bullion Butte, and Sentinel Butte areas of southwestern North Dakota where 261 lignite samples were taken from 85 surface sections and analyzed for uranium. Inferred reserves of 43,380,000 tons of lignite averaging 3.2 feet thick and underlying 7,845 acres are estimated for the four areas, the uranium content averaging 0.013 percent in the lignite and 0.040 percent in the lignite ash. (See table 12;).

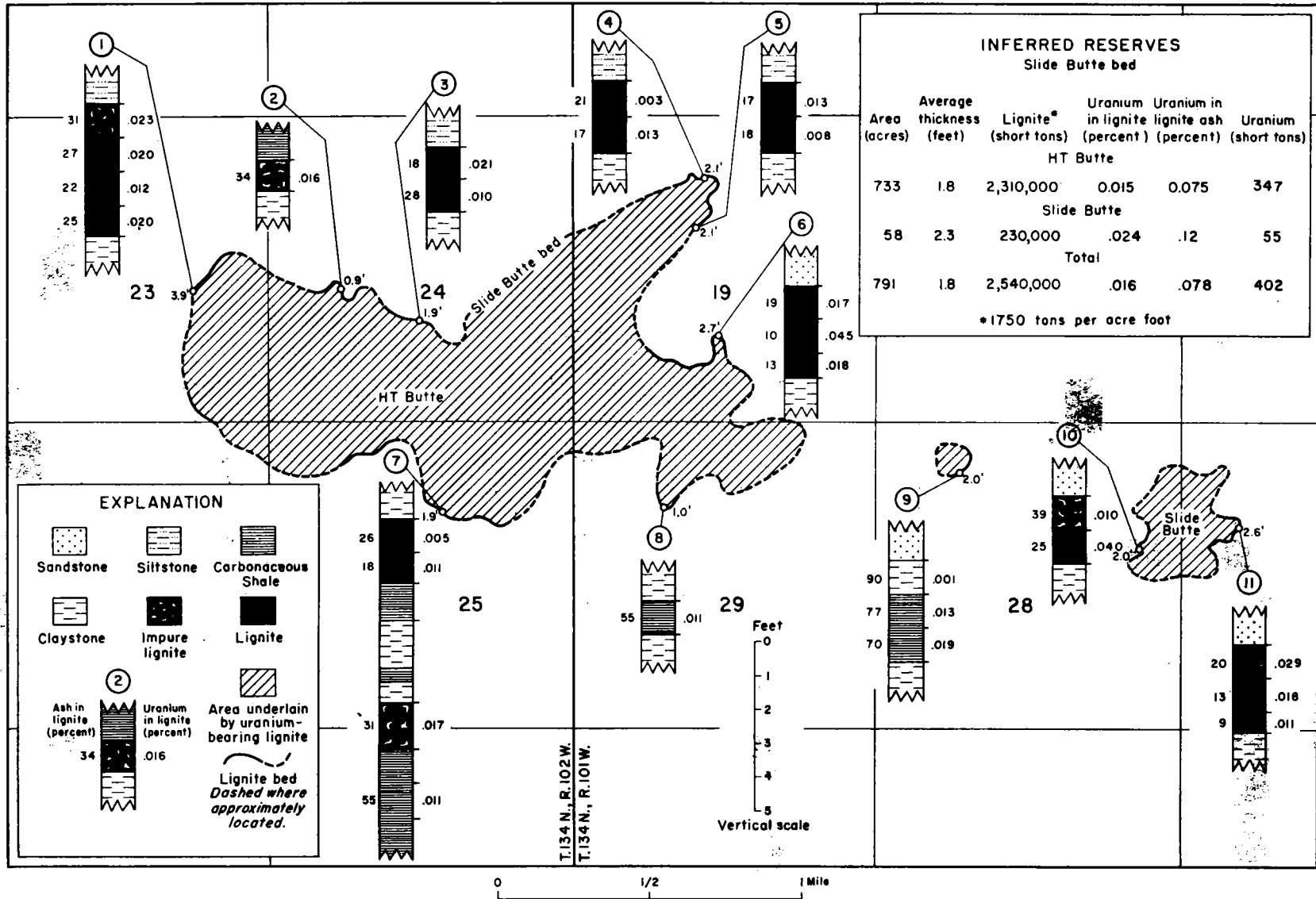

FIG. 18--RESERVES OF URANIUM-BEARING LIGNITE IN THE HT BUTTE AREA, SLOPE COUNTY, NORTH DAKOTA.

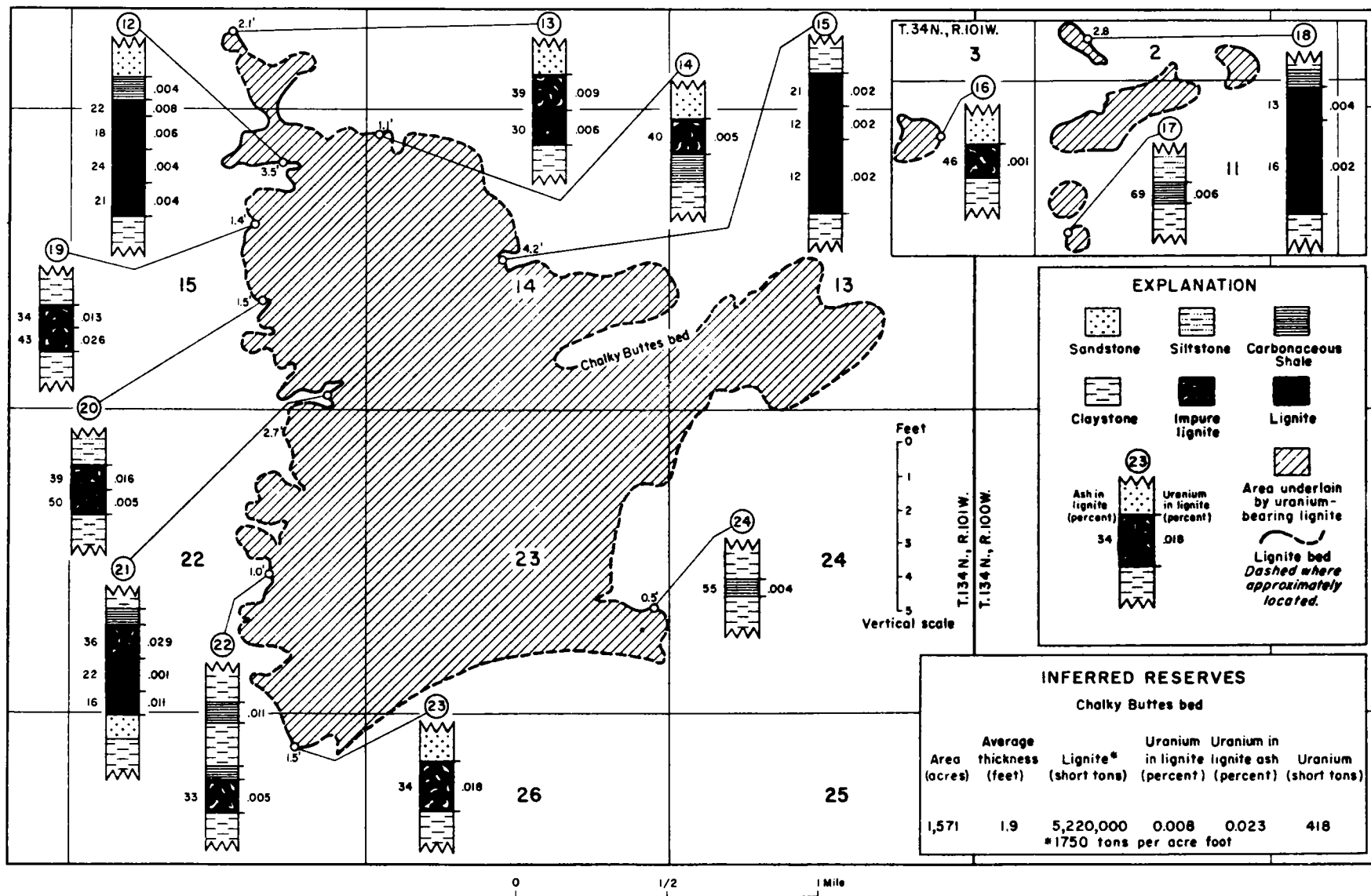

FIG. 19--RESERVES OF URANIUM-BEARING LIGNITE IN THE NORTHERN PART OF THE CHALKY BUTTES AREA, SLOPE COUNTY, NORTH DAKOTA.

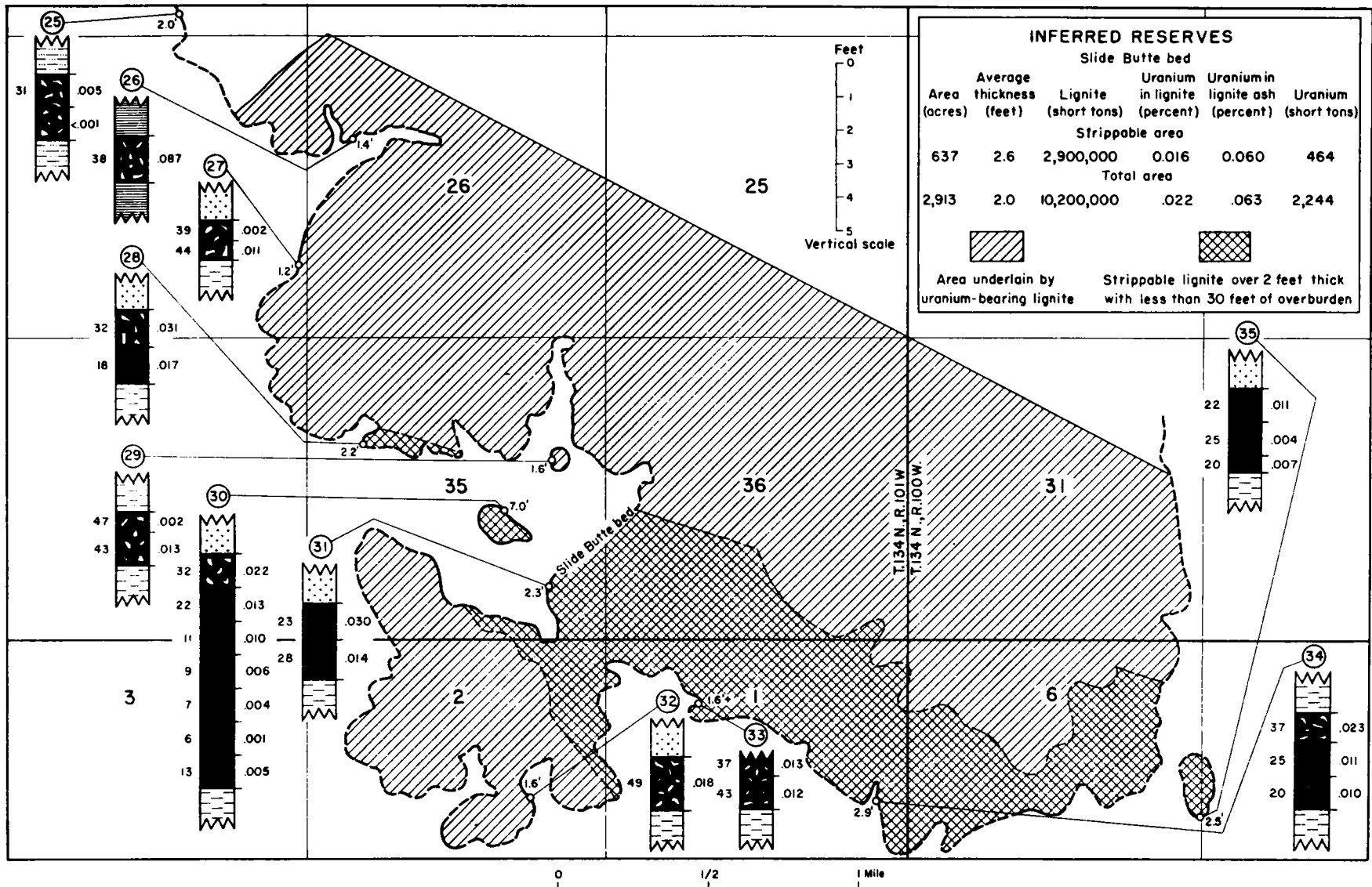

FIG. 20--RESERVES OF URANIUM-BEARING LIGNITE IN THE SOUTHERN PART OF THE CHALKY BUTTES AREA, SLOPE COUNTY, NORTH DAKOTA.

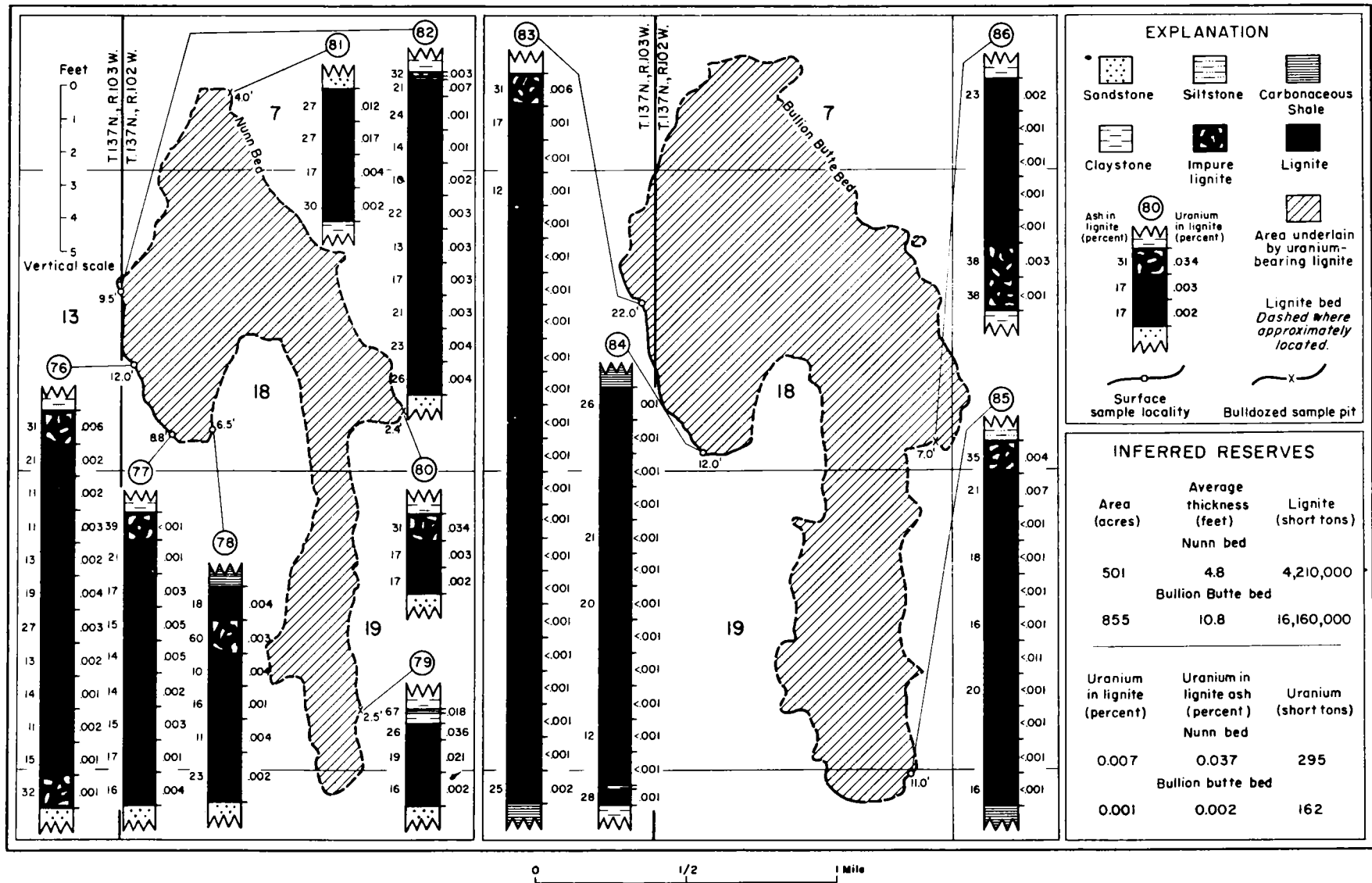

FIG. 21--RESERVES OF URANIUM-BEARING LIGNITE IN THE BULLION BUTTE AREA, BILLINGS AND GOLDEN VALLEY COUNTIES, NORTH DAKOTA.

The highest uranium content is in Slide Butte in the HT Butte area, Slope County (fig. 18), where the lignite contains 0.024 percent U and the ash 0.12 percent. The tonnage is small, however. The largest deposit is in Chalky Buttes, Slope County (figs. 19, 20), where 15,420,000 tons of lignite averaging 2.0 feet thick are estimated to underlie 4,484 acres, and to contain 2,662 tons of uranium. In Bullion Butte, Billings and Golden Valley Counties (fig. 21), uranium is contained in the Nunn bed, the stratigraphically highest bed in the butte, which has an average thickness of 4.8 feet, and in the upper few feet of the lower Bullion Butte bed, which averages 10.8 feet thick. In Sentinel Butte, Golden Valley County (fig. 22), a group of uraniferous beds near the top of the butte underlies about 500 acres. The uppermost bed is about 4 feet thick. At the east end of the butte the upper bed lenses out and the lower beds are more uraniferous.

A summary of the inferred reserves of lignite and uranium in southwestern North Dakota is given below:

Table 12.--Inferred reserves of uranium-bearing lignite in southwestern North Dakota

<u>Area</u> <u>(acres)</u>	<u>Average</u> <u>thickness</u> <u>(feet)</u>	<u>Lignite</u> <u>(short tons)</u>	<u>Uranium</u> <u>in lignite</u> <u>(percent)</u>	<u>Uranium in</u> <u>lignite ash</u> <u>(percent)</u>	<u>Uranium</u> <u>(short tons)</u>
HT Butte, Slope County, N. Dak.					
733	1.8	2,310,000	0.015	0.075	347
Slide Butte, Slope County, N. Dak.					
58	2.3	230,000	0.024	0.12	55
Chalky Buttes, Slope County, N. Dak.					
4,484	2.0	15,420,000	0.017	0.049	2,662
Bullion Butte, Billings and Golden Valley Counties, N. Dak.					
855	8.7	20,370,000	0.003	0.015	457
Sentinel Butte, Golden Valley County, N. Dak.					
<u>1,214</u>	<u>2.4</u>	<u>5,050,000</u>	<u>0.007</u>	<u>0.022</u>	<u>310</u>
TOTAL					
7,845	3.2	43,380,000	0.013	0.040	3,831

Three factors appear to influence the deposition of uranium in the southwestern North Dakota area: (1) stratigraphic position below rocks of the White River group of Oligocene age; (2) permeability of the enclosing sediments; and (3) thickness of the lignite beds (other things being equal, thin beds have a higher uranium content than thick beds). These and other factors suggest that the uranium in the lignite is secondary and that it was introduced by groundwater which had leached uranium from volcanic ash in rocks of the White River group.

Ekalaka lignite field, Carter County, Montana
by J. R. Gill

In the southern Ekalaka Hills approximately two square miles are underlain by uraniferous lignite beds, which are lenticular and range from 1.5 to more than 20 feet in thickness (figs. 23, 24). Approximately 16,500,000 tons of lignite containing 745 tons of uranium are estimated to be present in three beds having an average uranium content of 0.004 percent. (See figs. 23, 25).

The ash content of lignite samples from surface exposures ranges from 14 to 50 percent; the high percentage is due in part to the presence of analcite, barite, and gypsum. In all probability the unweathered lignite in the field has a much lower ash content.

The uranium is believed to be secondary and to have been leached and transported by ground water from overlying mildly radioactive tuffaceous sandstones which, in this area, are in the Arikaree formation of Miocene age. The rocks immediately overlying the lignites are permeable sandstones. In the northern part of the Ekalaka Hills the lignite beds are overlain by impervious shale and are not radioactive.

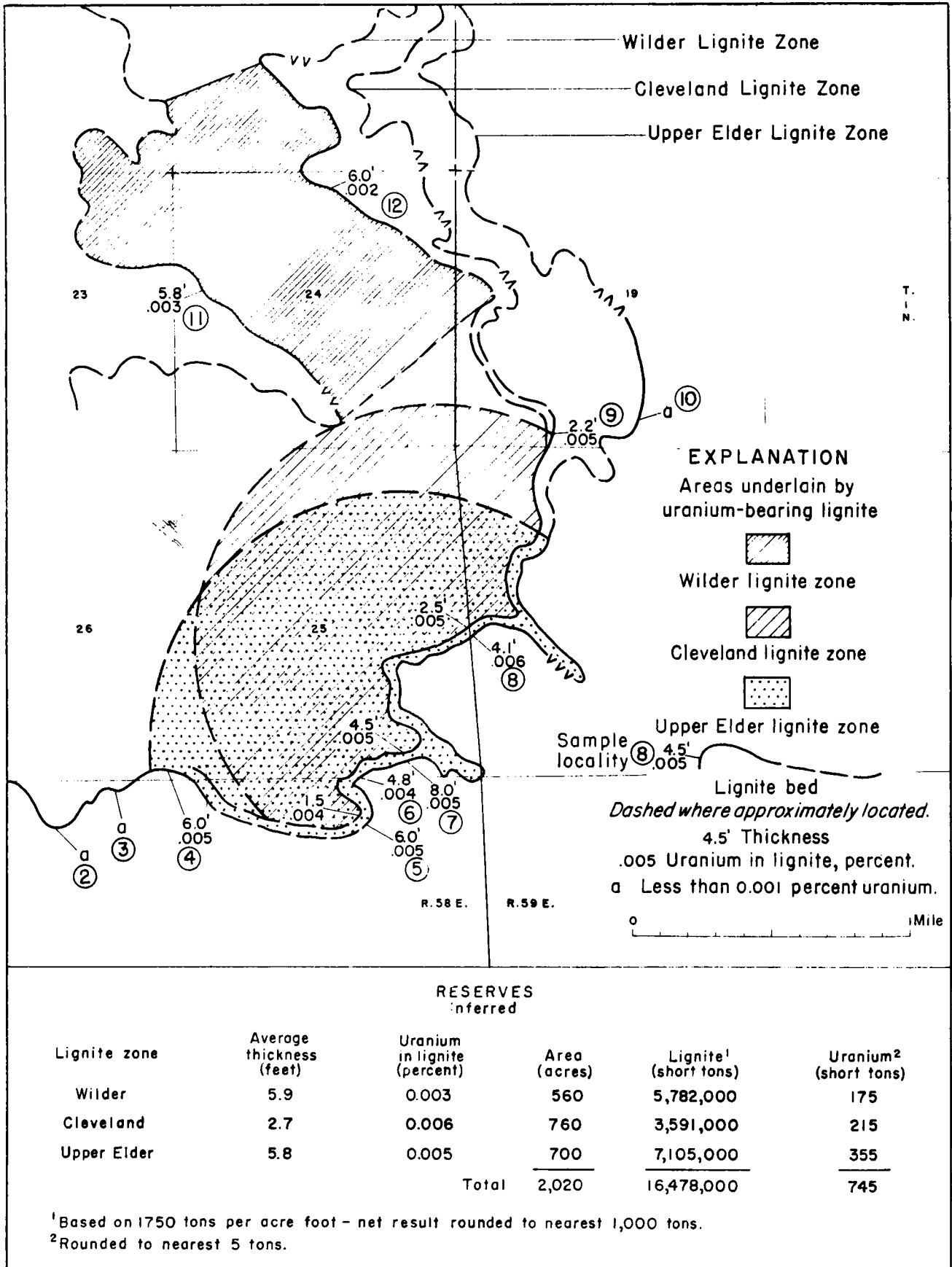

FIG. 23--MAP SHOWING AREA UNDERLAIN BY URANIUM-BEARING LIGNITE, EKALAKA HILLS, CARTER COUNTY, MONTANA.

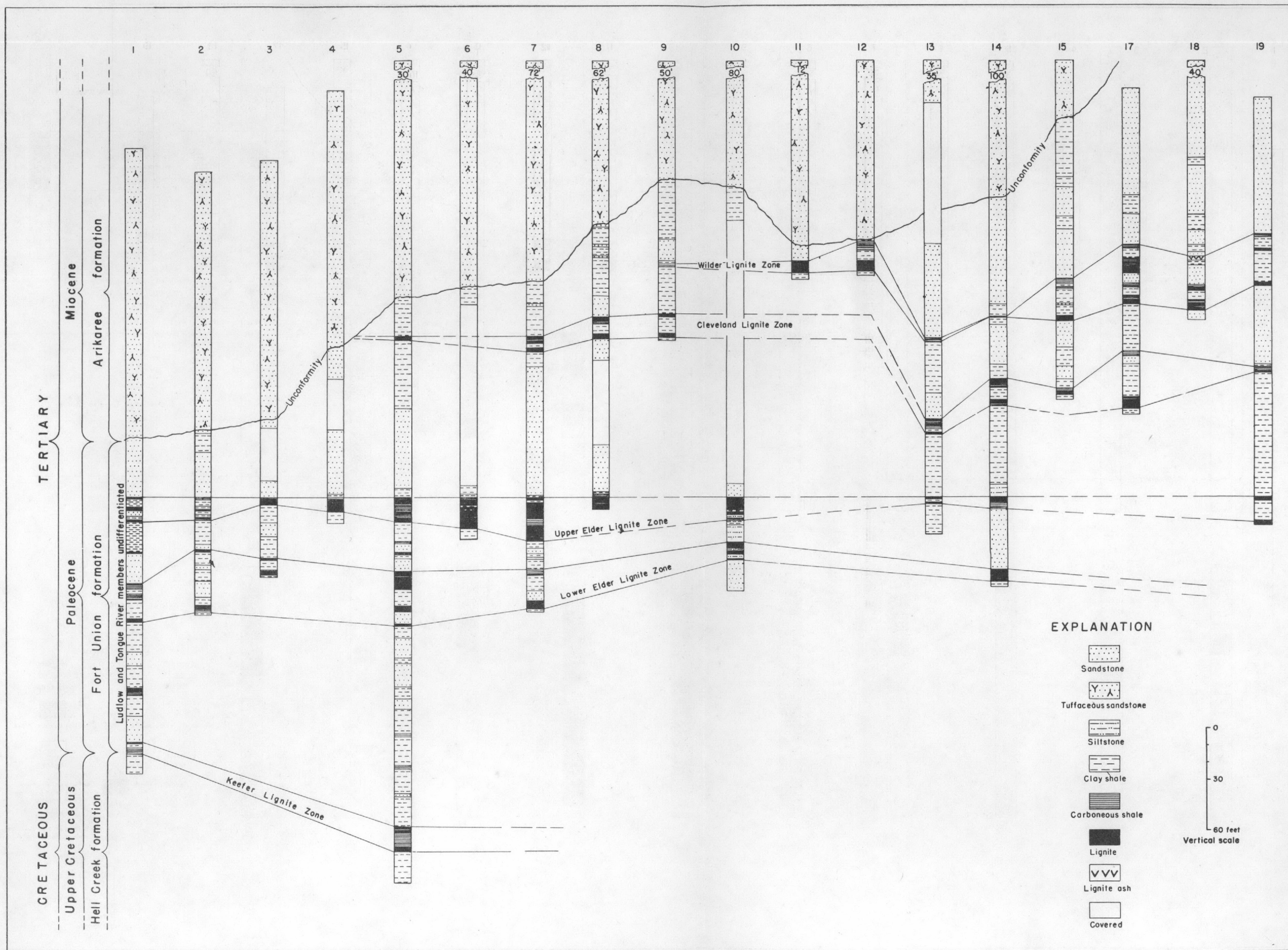

FIG. 24--STRATIGRAPHIC SECTIONS SHOWING CORRELATION OF LIGNITE BEDS EKALAKA HILLS, CARTER COUNTY, MONTANA.

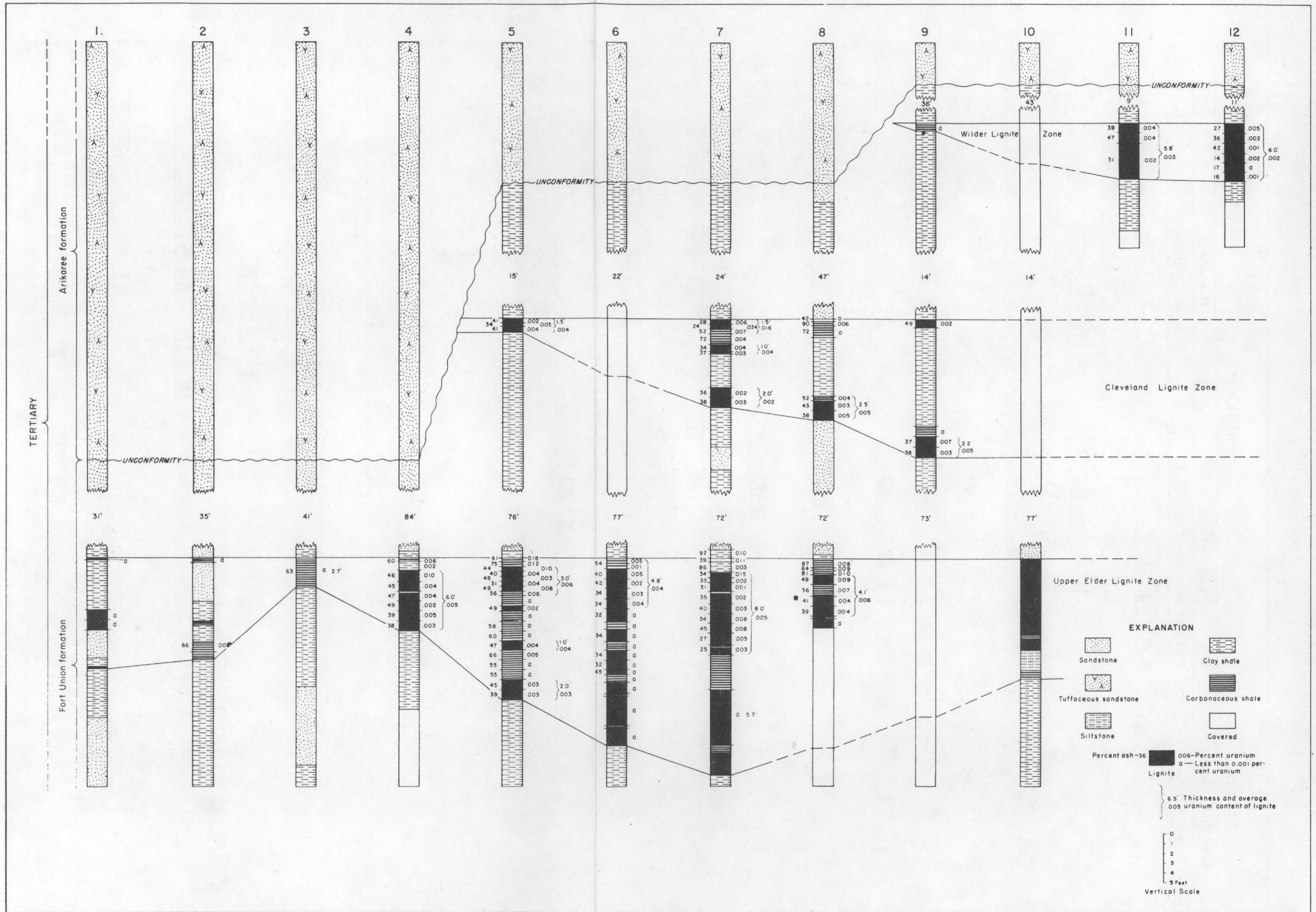

FIG. 25--CHART SHOWING CONCENTRATION AND DISTRIBUTION OF URANIUM IN LIGNITE BEDS, EKALAKA HILLS, CARTER COUNTY, MONTANA.

Mendenhall area, Slim Buttes, Harding County, South Dakota
by J. R. Gill

Core drilling in 1952 and 1953 in the Mendenhall area indicated reserves of approximately 127 million tons of lignite in four beds 3 to 12 feet thick which underlie about 4,000 acres. These reserves are listed below:

Table 13.--Measured reserves of lignite in the Mendenhall area

Bed	Av. thickness, feet	Area, acres	Average % ash <u>1/</u>	Lignite, short tons	Average fuel value, Btu <u>1/</u>
Mendenhall rider	5.3	540	11.7	7,883,000	6,000
Mendenhall	8.5	2,135	11.6	31,973,000	5,940
Olesrud (upper bench)	6.8	3,885	11.5	46,944,000	6,010
Olesrud (lower bench)	5.7	4,025	14.0	<u>40,494,000</u>	5,690
Total reserve				127,294,000	

1/ "As received" basis.

Of the total reserves of lignite in the Mendenhall area, about 30,000,000 tons are radioactive, in the Mendenhall rider, the Mendenhall and the Olesrud beds. As each of these lignites is radioactive only where it is the stratigraphically highest bed, reserve figures as well as core and analytic data for each bed are listed separately in table 14. The beds of uraniferous lignite are 3 to 11 feet thick and the average uranium content is about 0.008 percent (fig. 27 and table 14).

The lignite has an average ash content of about 18 percent and a heating value on the "as received" basis of about 5,900 Btu. Bulk samples of weathered lignite taken by the U. S. Bureau of Mines contain higher content of ash and lower heating value than core samples of unweathered material. For that reason the burning and ash preparation experiments made by the Bureau of Mines at Grand Forks, using bulk samples, does not

Table 14.--Summary of inferred reserve data on radioactive lignite and uranium, Mendenhall area, Harding County, South Dakota

Bed	Av. Thickness, feet	Area, Acres	Percent U in lignite	% Ash	Lignite Short tons	Uranium Short tons
<u>Minimum grade of 0.005 percent uranium in lignite</u>						
Mendenhall "rider"	4.9	385	0.012		5,046,000	525
Mendenhall bed	6.1	1,150	0.007		12,202,000	870
Olesrud bed (Upper bench)	5.2	1,405	0.007		12,823,000	940
Total		3,140			30,071,000	2,335

<u>Minimum grade of 0.010 percent uranium in lignite</u>						
Mendenhall "rider"	5.6	115	0.018		1,141,000	165
Mendenhall bed	4.5	530	0.010		4,211,000	425
Olesrud bed (Upper bench)	3.3	795	0.010		4,591,000	460
Total		1,440			9,943,000	1,050

<u>Minimum grade of 0.03 percent uranium in lignite ash</u> (in ash)						
Mendenhall "rider"	6.1	340	0.042	25.1	3,621,000	325
Mendenhall bed	6.1	1,110	0.041	16.6	11,634,000	805
Olesrud bed (Upper bench)	5.0	1,330	0.046	18.0	11,588,000	935
Total		2,780			26,843,000	2,065

<u>Minimum grade of 0.05 percent uranium in lignite ash</u>						
Mendenhall "rider"	4.0	190	0.065	25.5	1,335,000	195
Mendenhall bed	5.0	775	0.052	15.3	6,804,000	555
Olesrud bed (Upper bench)	4.3	890	0.058	15.9	6,660,000	605
Total		1,855			14,799,000	1,355

R.7 E.

R.8 E.

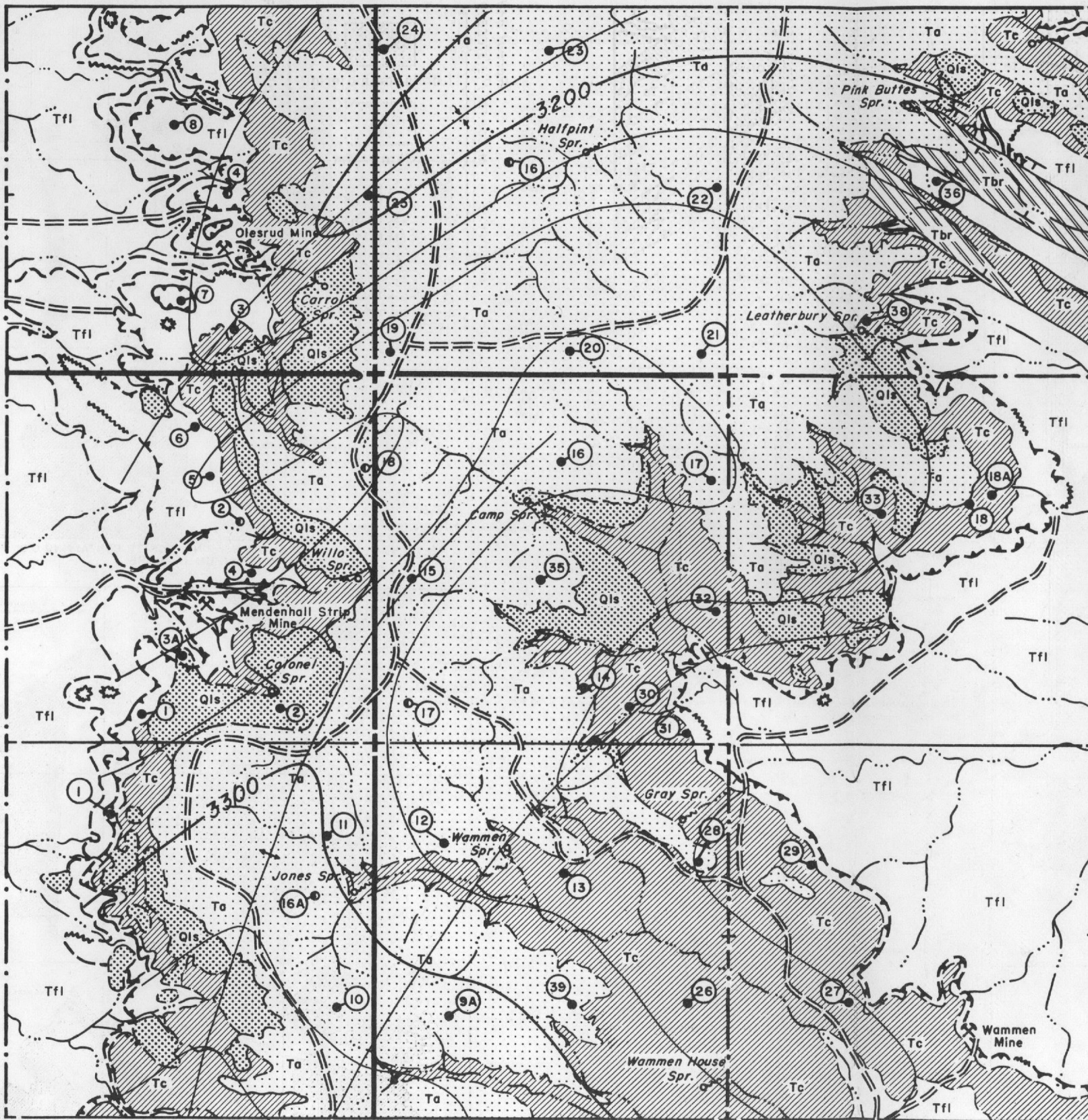

T. 18 N.

T. 17 N.

EXPLANATION

- Recent and Pleistocene
 - Qls
Landslide material
- Miocene
 - Ta
Arikaree fm.
- Oligocene
 - Tbr
Brule fm.
 - Tc
Chadron fm.
- Paleocene
 - Tfi
Ludlow member of Ft. Union fm.

QUATERNARY

TERTIARY

- Geologic contact
(Dashed where approximately located)
- Radioactive lignite
(Dashed where approximately located)
- Nonradioactive lignite
(Dashed where approximately located)
- Clinker
- Section corner recovered
- Custer National Forest boundary
- Core drill hole U.S.G.S. 1951
- Core drill hole AEC 1952-53
- Strike and dip of beds

-3300-

Contours on Olesrud bed (upper bench); contour interval 25'; datum mean sea level

Geologic mapping in 1953 by J.R. Gill. Base map compiled from aerial photographs.



Scale in feet

FIG. 26--GEOLOGIC MAP OF THE MENDEHALL AREA, SLIM BUTTES, HARDING COUNTY, SOUTH DAKOTA, SHOWING LOCATIONS OF CORE DRILL HOLES.

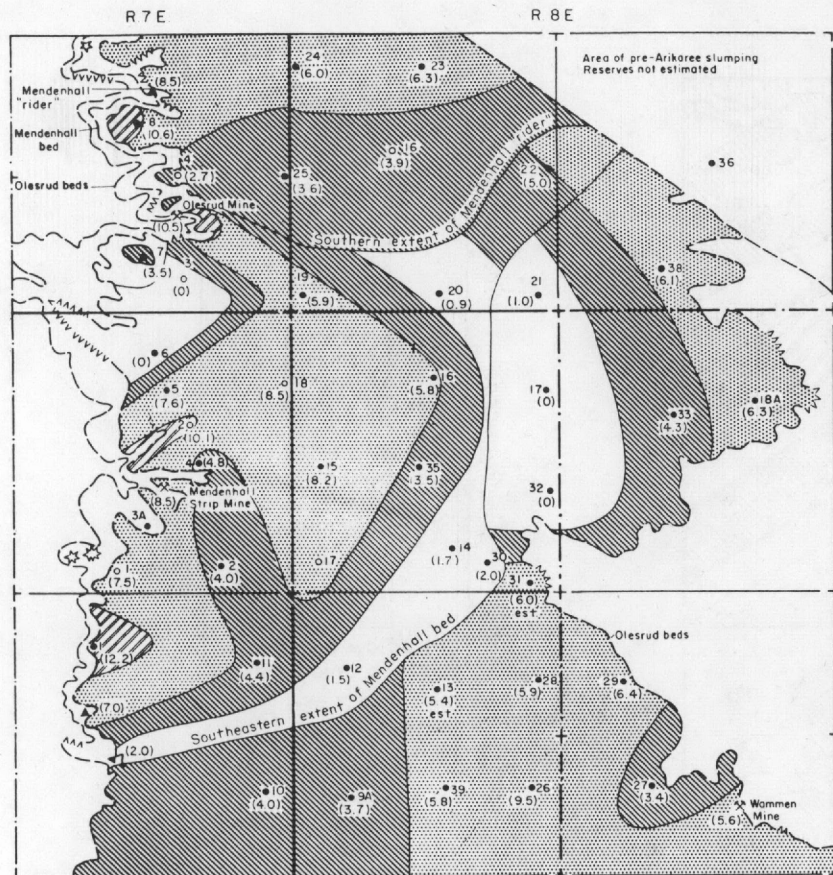

THICKNESS MAP OF URANIUM-BEARING LIGNITE CONTAINING 0.005 PERCENT URANIUM OR MORE

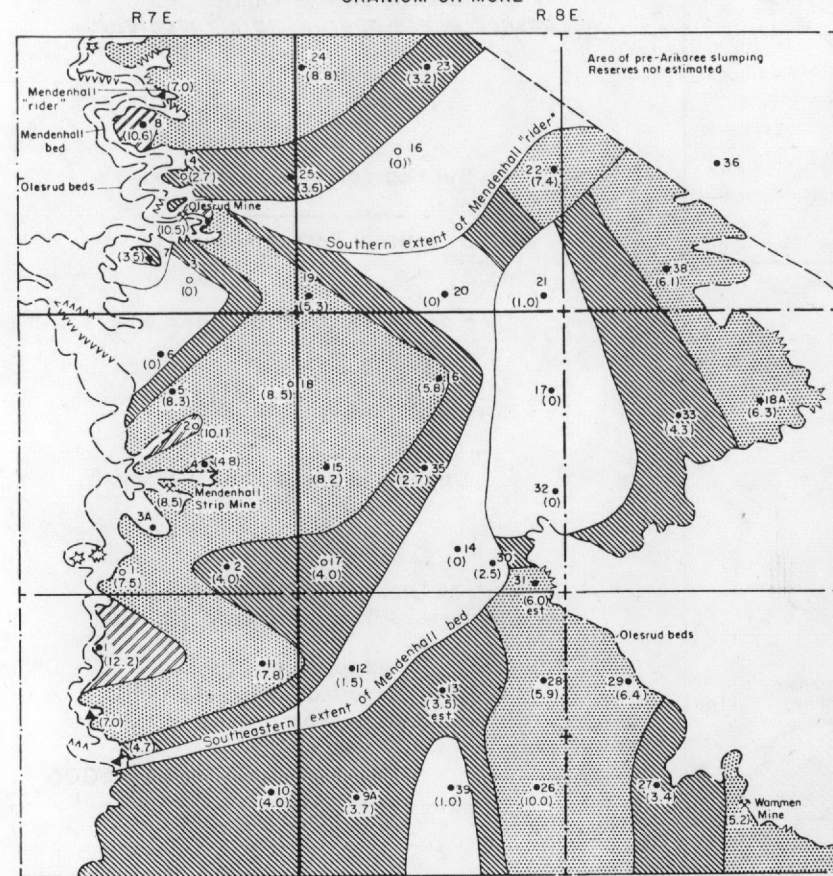

THICKNESS MAP OF URANIUM-BEARING LIGNITE CONTAINING 0.03 PERCENT URANIUM OR MORE IN ASH

URANIUM RESERVES (inferred)

Minimum grade of 0.005 percent uranium in lignite

Bed	Av. Thick. (Feet)	Area (Acres)	Percent uranium (In lignite)	Percent ash	Lignite (Short tons) ^{1/}	Uranium (Short tons) ^{2/}
Mendenhall "rider"	3.4	340	0.015		2,023,000	305
	6.9	235	.007		2,837,000	200
	10.6	10	.012		186,000	20
Subtotal		585			5,046,000	525
Mendenhall bed	4.2	465	.005		3,418,000	170
	7.1	645	.008		8,014,000	640
	11.0	40	.008		770,000	60
Subtotal		1,150			12,202,000	870
Olesrud bed (Upper bench)	3.9	635	.008		4,334,000	345
	6.3	770	.007		8,489,000	595
Subtotal		1,405			12,823,000	940
Grand total		3,140			30,071,000	2,335

Minimum grade of 0.01 percent uranium in lignite

Mendenhall "rider"	3.1	60	.025		325,000	80
	8.0	45	.010		630,000	65
	10.6	10	.012		186,000	20
Subtotal		115			1,141,000	165
Mendenhall bed	3.5	390	.010		2,389,000	240
	7.2	130	.010		1,638,000	165
	10.5	10	.010		184,000	20
Subtotal		530			4,211,000	425
Olesrud bed (Upper bench)	3.3	795	.010		4,591,000	460
		795			4,591,000	460
Subtotal		1,440			9,943,000	1,050
Grand total		1,440			9,943,000	1,050

Minimum grade of 0.03 percent uranium in lignite ash

Bed	Av. Thick. (Feet)	Area (Acres)	Percent uranium (in ash)	Percent ash	Lignite (Short tons) ^{1/}	Uranium (Short tons) ^{2/}
Mendenhall "rider"	3.3	140	.054	29.0	809,000	125
	7.9	190	.030	23.0	2,627,000	180
	10.6	10	.128	9.4	185,000	20
Subtotal		340			3,621,000	325
Mendenhall bed	4.0	370	.036	16.7	2,590,000	155
	6.7	690	.043	16.6	8,090,000	580
	10.9	50	.047	15.9	954,000	70
Subtotal		1,110			11,634,000	805
Olesrud bed (Upper bench)	3.8	770	.049	18.6	5,120,000	465
	6.6	560	.042	17.3	6,468,000	470
Subtotal		1,330			11,588,000	935
Grand total		2,780			26,843,000	2,065

Minimum grade of 0.05 percent uranium in lignite ash

Mendenhall "rider"	3.3	165	.063	26.9	953,000	160
	7.5	15	.050	15.0	197,000	15
	10.6	10	.128	9.4	185,000	20
Subtotal		190			1,335,000	195
Mendenhall bed	4.0	565	.050	14.9	3,955,000	295
	7.6	200	.057	16.3	2,660,000	245
	10.8	10	.050	17.0	189,000	15
Subtotal		775			6,804,000	555
Olesrud bed (Upper bench)	3.6	675	.059	16.2	4,252,000	405
	6.4	215	.055	15.0	2,408,000	200
Subtotal		890			6,660,000	605
Grand total		1,855			14,799,000	1,355

^{1/} Calculations based on 1750 tons per acre foot - net result rounded to nearest 1,000 tons
^{2/} Figures rounded to nearest 5 tons

EXPLANATION

THICKNESS OF LIGNITE

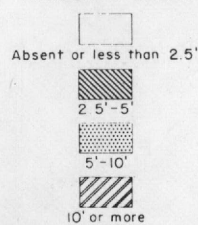

Lignite outcrop
 Dashed where approximately located

Clinker

Core hole A.E.C. 1952-53

Core hole U.S.G.S. 1951

Surface section

Number in parenthesis indicates thickness of mineralized lignite in core hole

Custer National Forest boundary

0 5,000 Feet

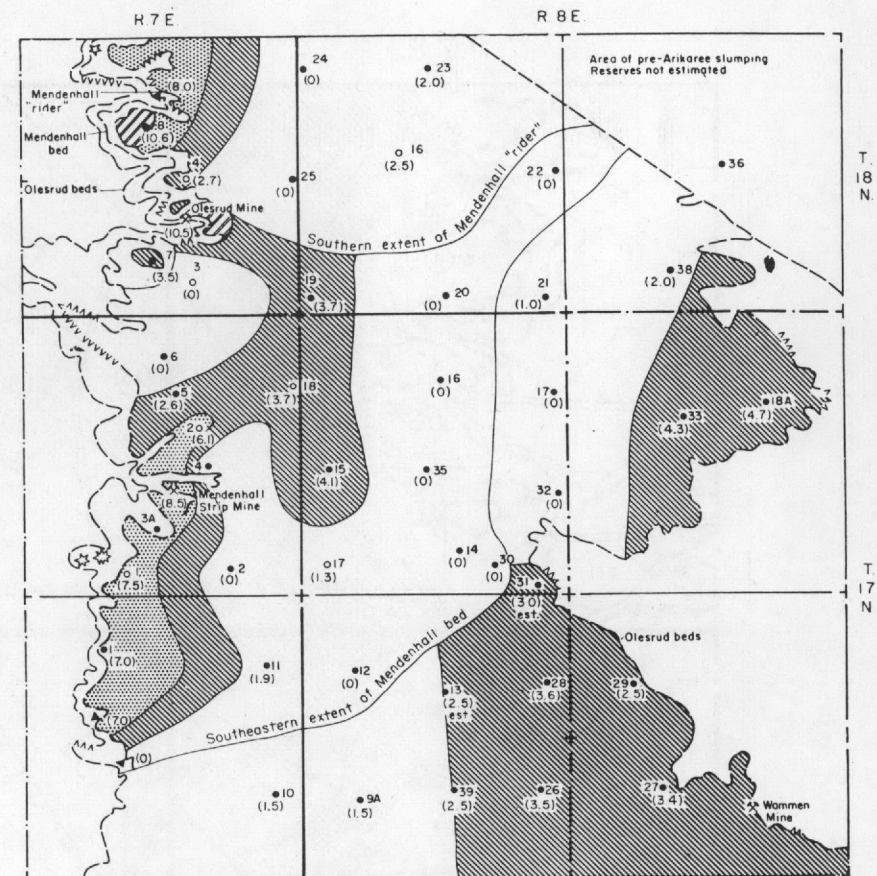

THICKNESS MAP OF URANIUM-BEARING LIGNITE CONTAINING 0.01 PERCENT URANIUM OR MORE

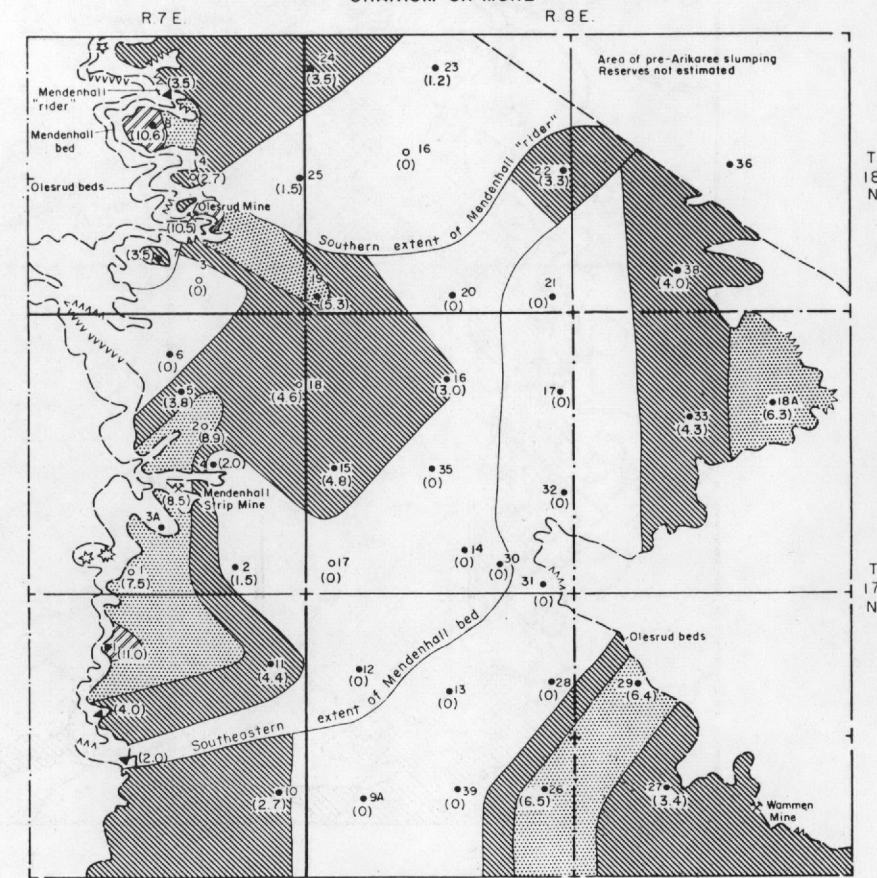

THICKNESS MAP OF URANIUM-BEARING LIGNITE CONTAINING 0.05 PERCENT URANIUM OR MORE IN ASH

FIG. 27--MAPS SHOWING THICKNESS, GRADE, AND DISTRIBUTION OF URANIUM-BEARING LIGNITE IN MENDENHALL AREA, HARDING COUNTY, SOUTH DAKOTA.

necessarily represent most of the lignite in the Mendenhall area.

A total of about 3,100 acres is underlain by radioactive lignite in the Mendenhall area. The overburden is less than 60 feet over about 680 acres, and from 60 to 120 feet over 650 acres. Thus a considerable tonnage could be mined by stripping.

Eastern Red Desert, Sweetwater County, Wyoming
By Harold Masursky, J. G. Stephens, and R. F. Gantnier

Estimates of inferred reserves of coal and uranium in the Eastern Red Desert area, Sweetwater County, Wyoming, based on 12,677 feet of core drilling in 60 holes (TEI-391) amount to 544 million tons of sub-bituminous coal averaging 8 feet in thickness and overlain by 75 feet or less overburden. The coal underlies about 60 square miles and contains about 14,000 tons of uranium, the average grade being 0.003 percent U. Heating value of the coal on the "as received" basis averages about 7,900 Btu, ash content 16 percent.

A 6.5-foot thickness of the Creston No. 4 coal bed at Creston Ridge (fig. 28) contains 0.024 percent U in the coal and 0.034 percent U in the ash.

Available analytical data include a close relationship between the occurrence of uranium and other trace constituents of the coal and (1) the permeability of the enclosing strata, and (2) proximity of the coal to an unconformity overlain by remnants of once-extensive gravel deposits of unknown age (fig. 29). The gravel deposits may be basal Browns Park formation of Miocene age or pediment deposits of Pleistocene age.

Spectrographic determinations show a close relationship between the occurrence of uranium and germanium, molybdenum, ytterbium, and yttrium

in the coal (fig. 29). Other chemical data show that iron has a similar relationship.

Optical and X-ray studies of the sediments indicate that the dominant clay minerals in both the fluviatile and lacustrine sediments of the Hiawatha member of the Wasatch formation of Eocene age are kaolinite and illite. These are probably derived by weathering from the feldspars (microcline, allite, and orthoclase) eroded from the Granite mountains to the northeast. In contrast, the common clay mineral in the overlying Laney-Morrow Creek members of the Green River formation of middle Eocene age is montmorillonite. This clay is possibly derived from the considerable admixture of volcanic material in the stratigraphically higher units.

Western Red Desert area, Sweetwater County, Wyoming
By G. N. Pipiringos

Results of analyses of coal samples from the Western Red Desert area indicate little change in previously reported coal reserves and their uranium content (TEM-601, TEI-332).

Of 25 representative samples of coal, 16 contain less than 0.001 percent U; the others from 0.002 to 0.010 percent U with an average of about 0.004 percent.

Of seven coal samples collected 15 to 50 miles west and southwest of the area, on the flanks of the Rock Springs Uplift, four contain less than 0.001 percent U; the rest contain from 0.002 to 0.025 percent U. The sample of highest uranium content analyzes 0.025 percent and is from a thin impure coal bed near the top of the Fort Union formation in S. 35, T. 21 N., R. 99 W., 7.2 miles north of the junction of U. S. Highway 30 with the road to Bitter Creek station.

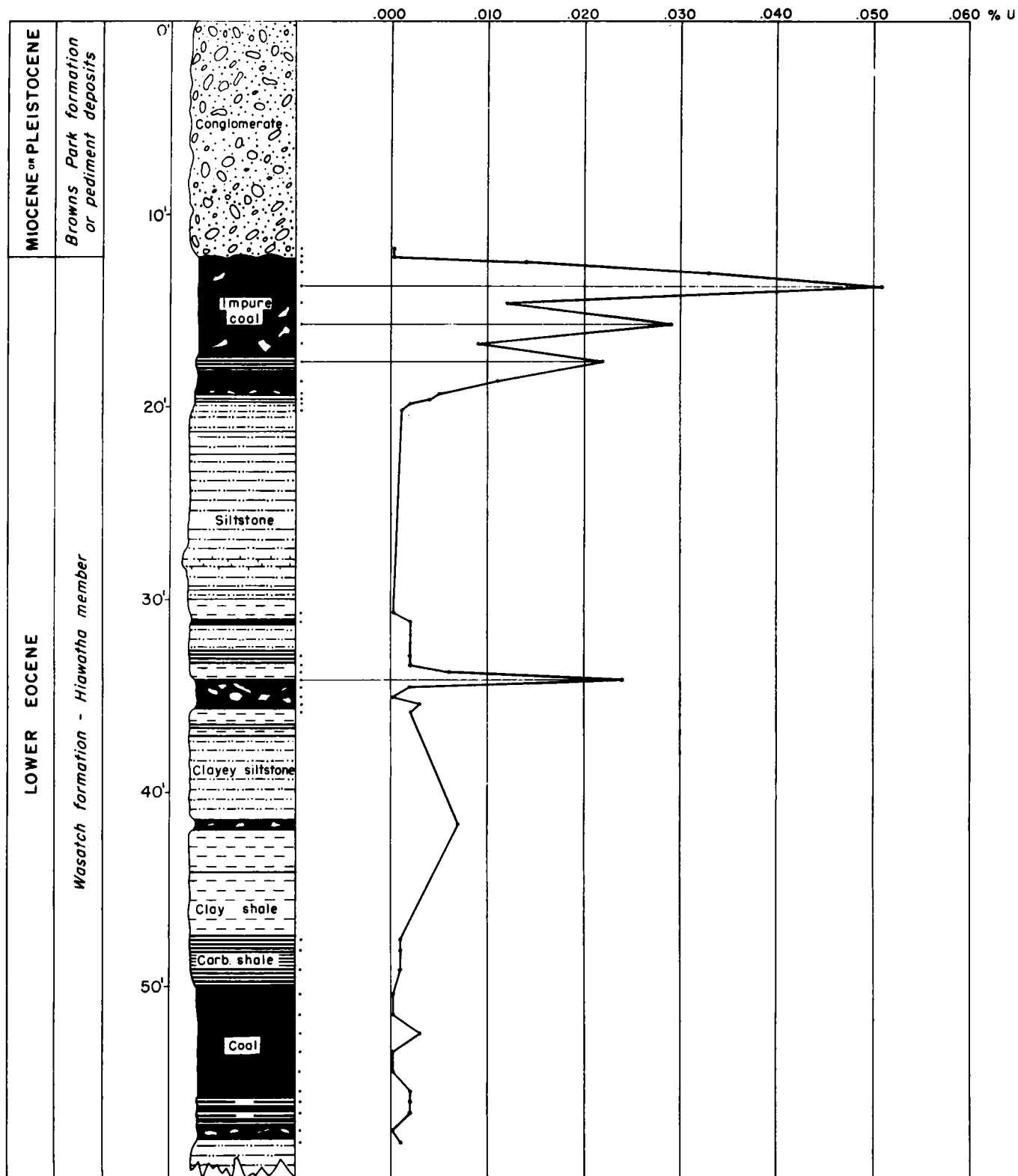

FIG. 28--COLUMNAR SECTION SHOWING DISTRIBUTION OF URANIUM IN THE CRESTON COAL ZONE AT CRESTON RIDGE, EASTERN RED DESERT AREA, SWEETWATER COUNTY, WYOMING.

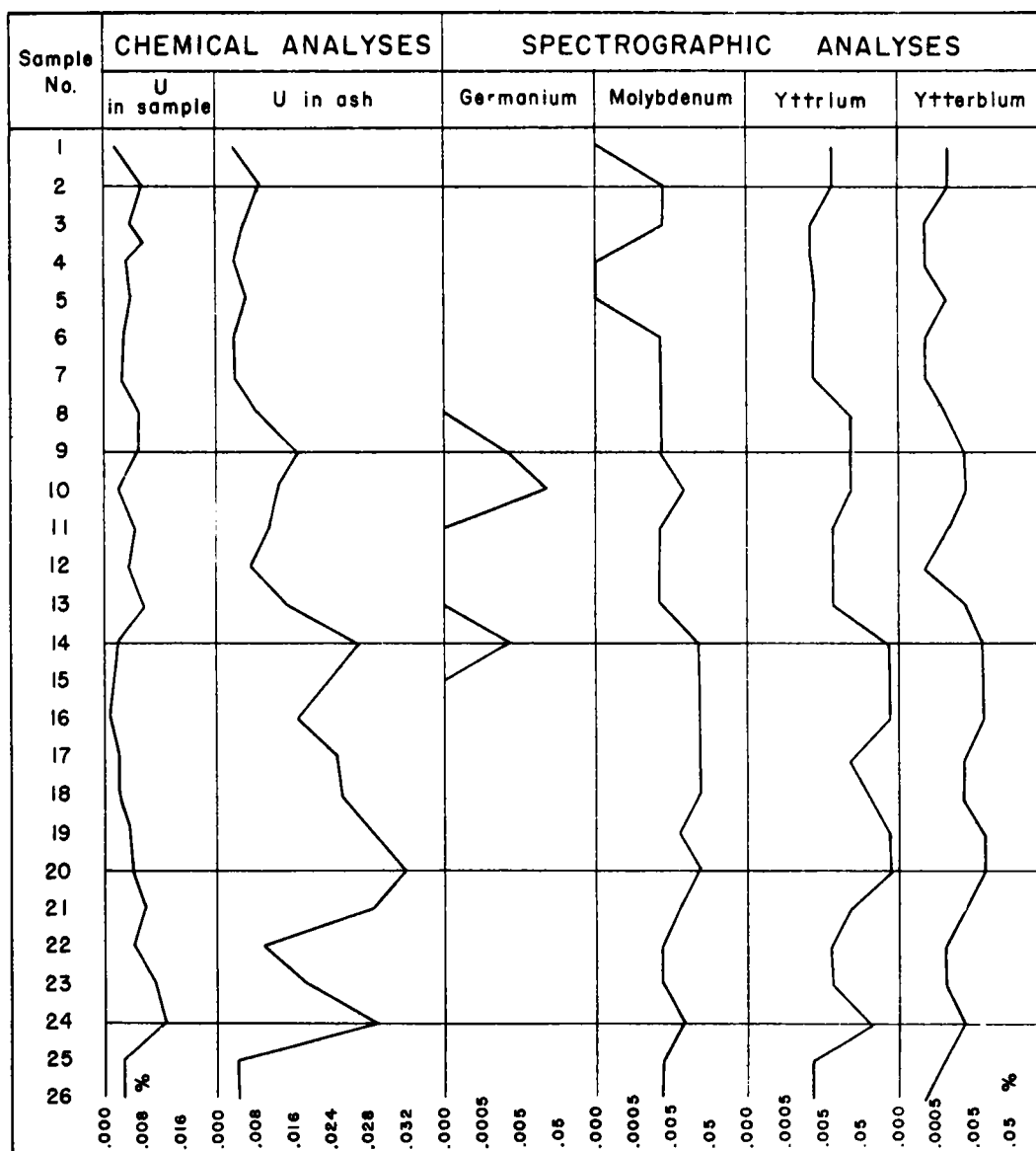

FIG. 29--DIAGRAM SHOWING DISTRIBUTION OF SELECTED TRACE ELEMENTS IN THE LUMAN COAL BED, CORE HOLE 72, SAMPLE INTERVAL 95.97 TO 101.95 FEET, RED DESERT AREA, SWEETWATER COUNTY, WYOMING

Uranium in lignite and coal
By I. A. Breger and Maurice Deul

Uraniferous coals

Isolation of organo-uranium complexes from a sample of lignite from Harding County, South Dakota, and from a subbituminous coal from the Red Desert area, Wyoming, was completed. As shown in Table 15, the uranium isolated with the extracts accounts for most of the total uranium present in the original samples on the basis of material balance calculations.

Table 15.--Analytical data for organo-uranium extracts

<u>Sample type</u>	<u>Ash (percent)</u>	<u>U in ash (percent)</u>	<u>U in extract U in coal (percent)</u>
Lignite from S. Dakota	60.3	0.145	95
Subbituminous coal from Wyoming	56.3	0.0130	87

The conditions under which these extracts were isolated were such as to preclude the hydrolytic precipitation of uranium from solution.

Preliminary infrared absorption spectra of the extracts from the two coals are practically identical and indicate the presence of the following structural units: -OH, -C-H, -C=C-, -C=O, and possibly -N-H. The high inorganic content of the extracts complicates interpretation of the spectra and it is yet to be determined if the inorganic components are present as entities, such as hydrous ferric oxide, or in metallo-organic associations. Ultimate analyses of these extracts will soon be obtained in an effort to aid in determining their structures.

Studies of an "unweathered" uraniferous lignite from Harding County, South Dakota, are in progress. An effort is being made to establish, by separation of mineral and organic components of the coal, how and where the uranium is held in this material. By comparing the results with those obtained from studies of weathered lignite, it will be possible to determine whether the weathering process has resulted in a redistribution of uranium within the components of the coal.

A sample of coal from the Fall Creek prospect in Idaho was studied in detail. The coal occurs as pods and lenses in a uraniferous carbonaceous shale. There are two groups of minerals present in the coal: one group, definitely secondary, in the cleats and fracture planes contains 0.003 percent U; another group, deposited with the woody material and incorporated in the coal, contains 0.033 percent U. As in the coals from Wyoming, the uranium was found to be associated with the organic matter. The data are tabulated below:

<u>Sample</u>	<u>Ash (percent)</u>	<u>U (percent)</u>	<u>Sample (percent)</u>
Original coal	29.6	0.079	100
Organic fraction	5.9	0.11	64
Mineral fraction	73.6	0.033	36
Secondary minerals	77.2	0.003	

The highly uraniferous coal from the Fall Creek prospect contains an unusually high concentration of germanium, as much as 0.2 percent in the ash of the coal. This association of germanium with uranium in pods and lenses of coal in a shale is suggestive of a similar association in the Chattanooga shale in Tennessee where thin layers and lenses of vitrain show high concentrations of uranium and germanium.

Organo-uranium associations in the Colorado Plateau region

Studies were initiated to characterize and relate the various types of organic material associated with uranium in the Colorado Plateau region. Before applying information gained from the study of massive uraniferous coals to the study of coalified wood in the Plateau, it was considered important to obtain information concerning the oil-impregnated sandstone, crude oil, and carbonaceous pellets which are found in association with coalified wood in the San Rafael Swell. All the samples studied were collected from the AEC No. 4 Mine in the Temple Mountain area. After extraction of the oil from the impregnated sandstone, the oil was treated with pentane to precipitate the asphaltenes which were then collected, dried, and ashed. A similar procedure was carried out with the oil collected from the oil seep. The ashes from the asphaltenes have essentially identical trace element assemblages and distributions such as are to be anticipated for crude oils. Semi-quantitative spectroscopic analysis of the carbonaceous pellets showed the unusual presence of ten of the fifteen rare earths and the absence of detectable sodium. This remarkable trace element assemblage is interpreted to indicate that the pellets were probably not of petroliferous origin. Inasmuch as the pellets contain very appreciable percentages of uranium, in contrast to the crude oil in the San Rafael Swell, more work is planned in an attempt to establish their origin and structure.

A program was planned and equipment ordered for study of the role played by coalified wood in the emplacement of uranium and vanadium in the Colorado Plateau region.

Coal petrography
by J. M. Schopf, R. J. Gray, C. J. Felix, and J. C. Warman

Initial studies of uraniferous coal from the Slim Buttes area in South Dakota and carbonaceous shale from the Goose Creek area in Idaho suggest that highly degraded organic matter in coal is most favorable to uranium emplacement (TEI-408). These studies also indicate that uranium occurrence in coal must be controlled by several factors, as analysis failed to disclose any single component or group of components with which direct correlation could be established. The fact that the coal layers with a relatively high uranium content also contain an abundance of highly degraded materials provides an interesting avenue for further investigation. Most of the material suitable for microscopic study from the Dakota area (about 600 sections) has now been prepared and microscopic studies and collation of analytical results are in progress.

The 8-inch core from Hole 72 which sampled the Luman No. 1 coal zone in the northern Red Desert area in south-central Wyoming has been studied intensively. This coal is of Eocene age and is on the border of the area of Green River lake deposits. The lithologic and radioactivity profile for the Luman No. 1 coal zone in Hole 72 is shown in fig. 30. The core was sampled in 84 separate intervals, averaging about 1/10 of a foot in thickness, to establish the radioactivity profile. The curve is based on duplicate determinations of pulses per minute per gram of sample (P/M/G). Forty-nine duplications or combinations of laboratory samples were submitted as TE samples for chemical determination of uranium and spectrographic analysis. The chemical results show an excellent correlation with the P/M/G profile (1 P/M.G=27.2 ppm U) and this has served as a basis for general comparison.

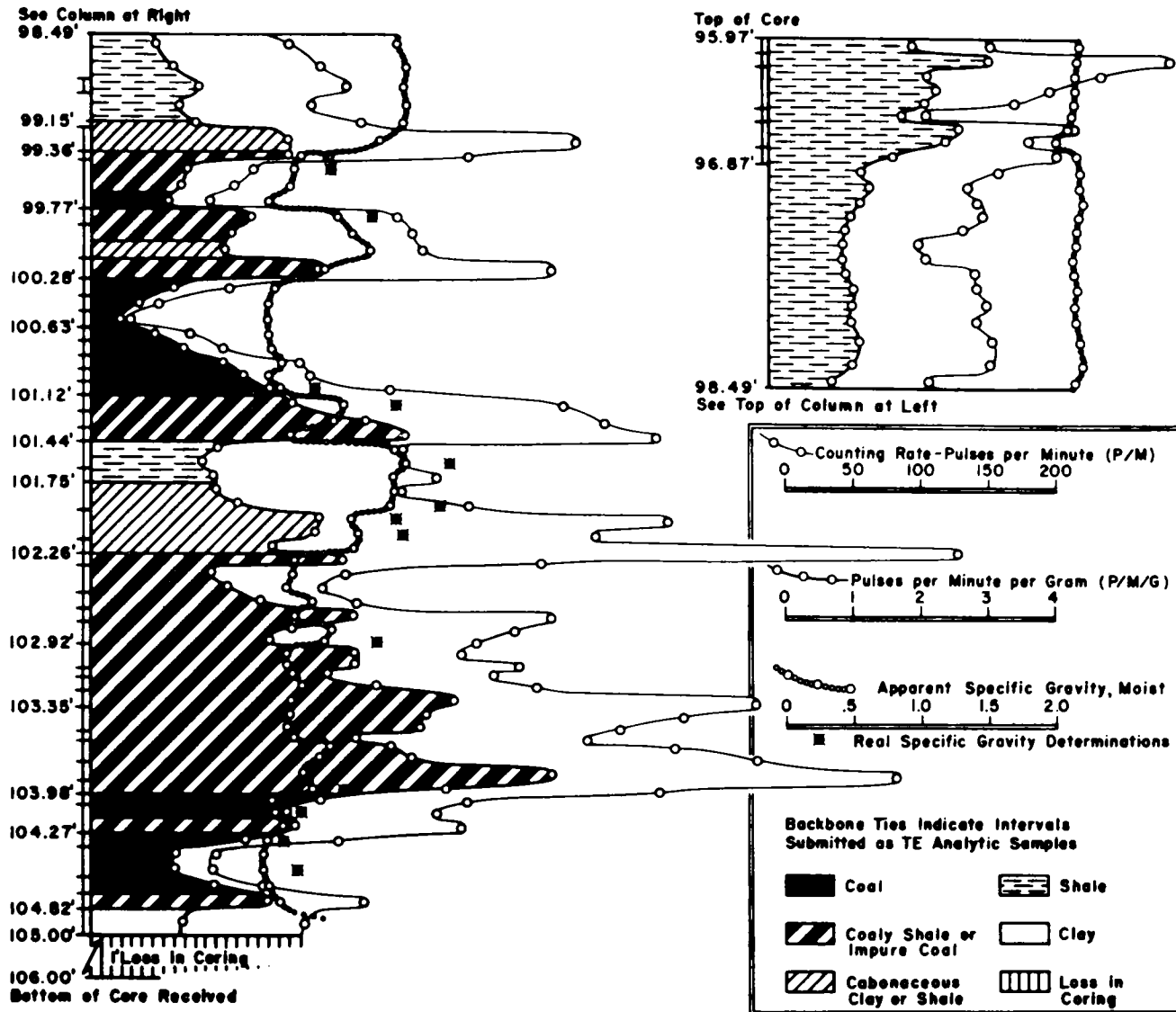

FIG. 30--COMPARISON OF RADIOACTIVITY VALUES WITH APPARENT SPECIFIC GRAVITY AND LITHOLOGY OF MOIST SAMPLES TAKEN FROM 8" DIAMETER CORE OF RED DESERT HOLE 72.

Highest uranium values occur in coaly shale and impure coal and considerably lesser amounts in purer coal and in the slightly carbonaceous strata. As Breger and others have shown uranium to be related to the organic matter and not to the minerals at a nearby outcrop locality in this same coal zone (TEI-389), the explanation for this condition is not immediately apparent. Previous core processing investigations (TEI-390, p. 150) have indicated that uranium association with impure coal is probably widespread in the Red Desert area.

As determinations of radioactivity do not ordinarily show so close a correlation with uranium content, a study has been made of the apparent specific gravity of each of the moist samples. This is plotted as an additional profile in figure 30. From these determinations the extent of correction introduced by dividing the counting rate (pulses per minute) by weight of sample can be estimated. The correlation of the apparent density of the samples with the varying mineral content, as indicated by lithology, is also evident.

Real specific gravity has been determined for sixteen selected sample layers ranging in ash content (air dry condition) from about 10 to over 90 percent. These are represented by disconnected points in figure 30. Presumably the pore space is roughly proportional to the difference between the real densities and the apparent moist densities of the samples. The lower density samples (purer coal) show less difference between the real and apparent specific gravities than the high density samples (slightly carbonaceous and coaly shale, more impure varieties of coal). Since it is evident that the purer coal contains the least uranium and the impure coaly layers the most, the influence of porosity (and permeability) may be significant. Masursky and Pippingos (TEM-601) have suggested that uranium

is associated with zones of greater permeability in the Red Desert area.

A thorough microscopic study of pure and impure coaly layers has been completed, based on quantitative study of nearly a hundred thin sections. This information is summarized in charts to show correlative relations to uranium content, ash and coal analytic determinations. The results are given in figure 31 on a visually pure basis to eliminate from the analysis so far as possible the variable effects of dilution by mineral matter. Although visible mineral matter is never equal to the ash percentage, there is a sufficiently close parallel between the amounts of visible impurities and the ash content to suggest that the ash is nearly all of detrital origin.

The Luman No. 1 coal zone is dominantly attrital (fig. 31); on the visually pure basis it contains about 46 percent anthraxylon, 53.2 percent translucent attritus, .5 percent opaque attritus and .3 percent fusain. Coarse woody fragments are present in the upper part of the zone to account for 21 percent vitrain but these are much rarer below. There is no evidence of roots in the clay below the lower zone or in other parts of this core. The carbonaceous and coaly material probably was transported to a large extent from its site of origin and accumulated as a lagoonal peaty deposit, possibly comparable to some of the gulf coast lagoonal peats of the present day.

Whether any of the coarse woody remains grew close to the present site of deposit is uncertain as they also could have been floated for some distance. The greater amount of woody material in the upper part of the deposit suggests a shallower depth of water, at least, and a greater possibility that peaty material was locally derived. The Luman No. 1 coal zone evidently represents a marginal temporary facies coeval with some of

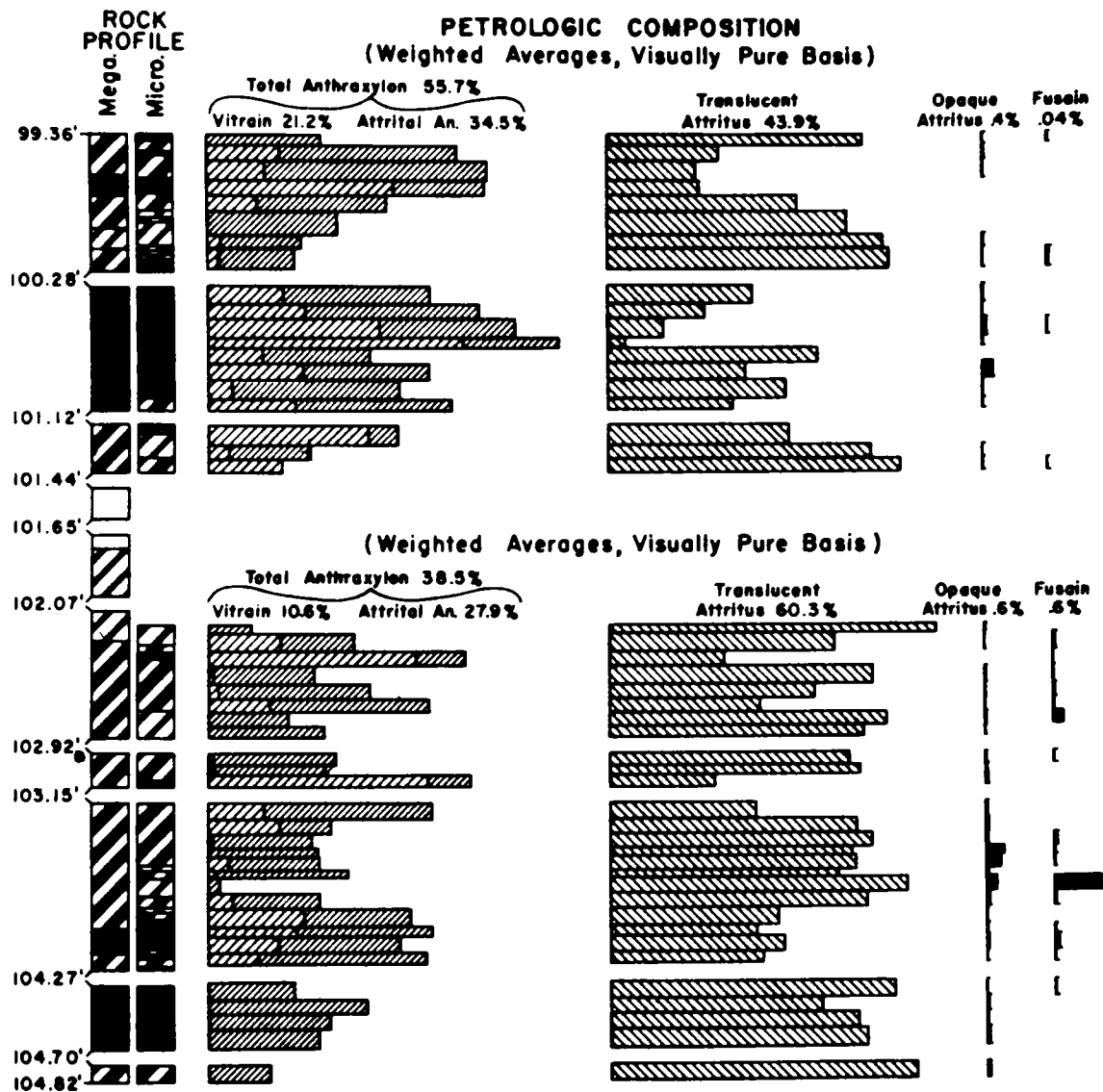

FIG. 31--PETROLOGIC COMPOSITION, VISUALLY PURE BASIS, RED DESERT HOLE 72.
(OMITTING BOTH MICRO- AND MEGASCOPICALLY VISIBLE MINERAL IMPURITIES)

the varved Green River oil shale deposits. The origin of this coal and its relation to the occurrence of uranium must be regarded in this light.

Core processing
by

J. M. Schopf, J. C. Warman, R. J. Gray, and C. J. Felix

The last cores (Holes 66, 68, 70, 71, and 72) from exploration of the Red Desert area in southcentral Wyoming were described and sampled for trace elements determination and for fuel analyses. Radioactivity determinations were made of 351 samples representing the full thickness of cores received, including those of the 8-inch core from Hole 72.

The origin and amounts of core processed, laboratory report numbers, and number of samples submitted from each of the cores received during the last three years has been compiled in table 16 as a summary of this work.

Black shales

Eastern states
By J. R. Pepper

Review of the literature to collect and summarize data on all black shales east of the Mississippi River was continued. Summaries of available information on distribution, thickness, stratigraphic position, and physical characteristics were completed for the Antrim shale in Michigan and the Nonesuch shale in Michigan and Wisconsin, and work is in progress on summaries of the Ohio shale and its equivalents in Ohio and Kentucky. Special emphasis is given in these studies to all pertinent information regarding composition and environment of deposition, in order to relate these data to the distribution of uranium in the rocks. As an aid to

Table 16--Tabulation of core processed at Coal Geology Laboratory
for AEC projects

Hole	Linear feet of core processed	P/M/G samples	TE samples	B of M samples	Linear feet of coal in B of M samples	Coal Geol. Laboratory report nos.
Slim Buttes area, Harding County, S. Dak.						
1	12.75	-	10	2	6.35	9
2	19.08	26	17	2	14.77	10
3	39.04	40	33	5	28.27	11
4	18.48	42	16	5	12.85	12A, 12B
SD-8	37.9	86	10	4	17.87	83, 84
SD-10	25.50	78	48	2	9.32	71, 72
16	18.15	35	24	1	8.40	22
17	15.25	31	14	4	10.69	23
18	24.83	34	19	4	14.21	24
19	26.42	-	15	3	6.41	25
SD-19	67.64	164	65	5	26.75	74, 75, 76, 77
21	15.56	25	17	3	9.44	26
22	7.12	17	10	3	4.78	41
23	14.38	35	21	3	4.65	42
24	14.67	33	18	4	8.25	44
25	14.42	27	13	2	6.75	47
26	13.40	25	17	2	9.76	48
K-26	13.5	21	10	2	6.25	105
27	6.63	15	4	1	2.06	49
Mendenhall						
Mine Column	5.08	27	27	5	3.38	46
Medicine Pole Hills area, Bowman County, N. Dak.						
5	5.50	-	6	1	3.89	13
6	7.17	-	7	2	5.68	14
8	5.42	-	3	1	2.50	15
9	6.75	-	6	1	5.04	16
Lodge Pole area, Perkins County, S. Dak.						
11	12.75	-	10	3	8.26	17
12	12.75	-	10	1	7.63	18
13	5.83	-	7	1	2.65	19
14	8.50	-	17	1	7.65	20
15	5.88	-	12	1	5.88	21
Leyden, Colorado						
1	39.8	4	39	4	20.92	28
2	34.3	-	24	6	21.1	29
3	11.41	-	8	3	10.48	30
4	21.2	-	27	3	12.52	31

Table 16.--Continued

Hole	Linear feet of core processed	P/M/G samples	TE samples	B of M samples	Linear feet of coal in B of M samples	Coal Geol. Laboratory report Nos.
Red Desert area, Sweetwater County, Wyoming						
1	10.86	22	19	2	5.63	63
2	33.04	41	41	5	6.9	55
3	27.42	38	37	3	6.25	56
4	32.93	70	61	4	19.67	57,62
5	7.11	53	15	1	2.56	58
6	5.31	14	14	1	4.04	60
7	8.87	21	15	1	4.83	61
8	5.48	12	10	1	4.04	64
9	6.0	15	15	1	1.12	65
10	37.17	85	85	6	22.0	66
11	45.73	105	105	5	17.69	67
12	15.9	22	4	1	1.27	80,81
13	46.9	81	41	1	4.89	78,79
16	38.9	62	16	2	3.92	85,86
17	55.7	125	29	3	14.29	87,88
24	33.3	64	25	2	5.39	89,90
32	14.6	35	4	2	8.69	95,98
33	13.7	27	6	-	-	97,99
34	29.9	69	26	1	4.17	100,101
40	49.3	101	5	3	20.35	102,103
43	39.1	79	4	2	20.88	106,107
46	23.0	33	18	-	-	108,111
49	130.5	263	57	7	40.25	110,112
50	41.3	64	11	1	2.19	113,114
53	107.6	107	19	3	9.73	115,116
58	19.8	28	4	-	-	121,122
63	59.3	114	9	2	11.07	124,125
64	100.8	194	11	5	27.16	126,127
66	53.70	70	4	2	12.35	129,130
68	55.15	63	9	-	-	133,134
70	54.22	59	9	4	23.16	135,136
71	70.00	75	36	-	-	137,138
72	9.03	84	49	12	9.96	140
Goose Creek area, Cassia County, Idaho						
2	35.0	60	32	1	4.16	117,119
3A	4.0	7	-	-	-	118,120
Totals						
68	1,907.68	3,127	1,429	174	644.02	98 Lab. Repts.

future field work on the shales of potential interest, a record is kept of the information, not currently available from published sources, that is needed to develop adequate knowledge of the physical properties of each shale and its environment of deposition.

Texas
By D. H. Eargle

The nature, amount, and distribution of radioactivity in the Eagle Ford clay was studied from Dallas in northeast Texas to the Eagle Mountains in Hudspeth County, West Texas. The work included a general reconnaissance of the formation, detailed measurement of sections, collection of well cores down dip from the outcrop, and sampling of both outcrops and cores for laboratory analysis. Data from wells, including radioactivity and electric logs, have been collected and the thickness of the formation determined down dip. In addition to the Eagle Ford clay, several formations in stratigraphic proximity have been studied in part, and study and spot sampling of Paleozoic rocks in several localities made.

The laboratory data received to date on samples of the Eagle Ford clay and the other formations are summarized in table 17. The data are classified by formation and lithology. The accompanying map (fig. 32) shows the outcrop of the Eagle Ford clay and the location of the sections measured and sampled and of the well cores received.

Analyses showing the equivalent uranium and uranium content of 57 samples from the outcrop and the equivalent uranium content only of 19 more have been received. Without exception laboratory results show that the uranium content of the Eagle Ford clay east of the Pecos River is less than 0.001 percent, whereas the radioactivity is as high as 0.004 percent eU on

Table 17.--Radioactivity and uranium content
of sedimentary rocks of Texas
(Averages)

Formation and lithology	No. samples	eU%	U%	Remarks
Cretaceous:				
Escondido formation				
Clay	3	.0013		Not analyzed for chem U
Asphaltic sandstone	1	.001		
Lignite	1	.001		
Eagle Ford clay				
Siltstone	15	.0013	<.001	Includes tuffs
Clay	21	.0014	<.001	Includes bentonite
Bentonite	5	.0025	<.001	
Limestone	4	.001	<.001	Incl. phosphatic limestone
Coal	4	.0018	.0035 (in ash)	24.82% ash
Pepper clay	4	.0015	<.001	
Buda limestone	2	.001	<.001	
Del Rio clay	17	.001	<.001	
Georgetown limestone				
Asphalt	1	.001	<.001	Dike along fault
Devonian:				
Woodford chert				
Shale	2	.0045	<.001	Well cores
Ordovician:				
Maravillas chert				
Shale	1	.004	.003	Shale beds in black chert
Lithology (all formations)				
Siltstone, includes tuff	15	.0013	<.001	
Clay, including bentonite	48	.0013	<.001	
Shale (in Maravillas chert)	1	.004	.003	
Bentonite	5	.0025	<.001	
Black shale (Woodford)	2	.0045	<.001	Well cores
Limestone	6	.001	<.001	
Asphalt	2	.001	<.001	
Lignite	1	.001		Not analyzed for U
Coal	4	.0018	.0035 (in ash)	24.82% ash

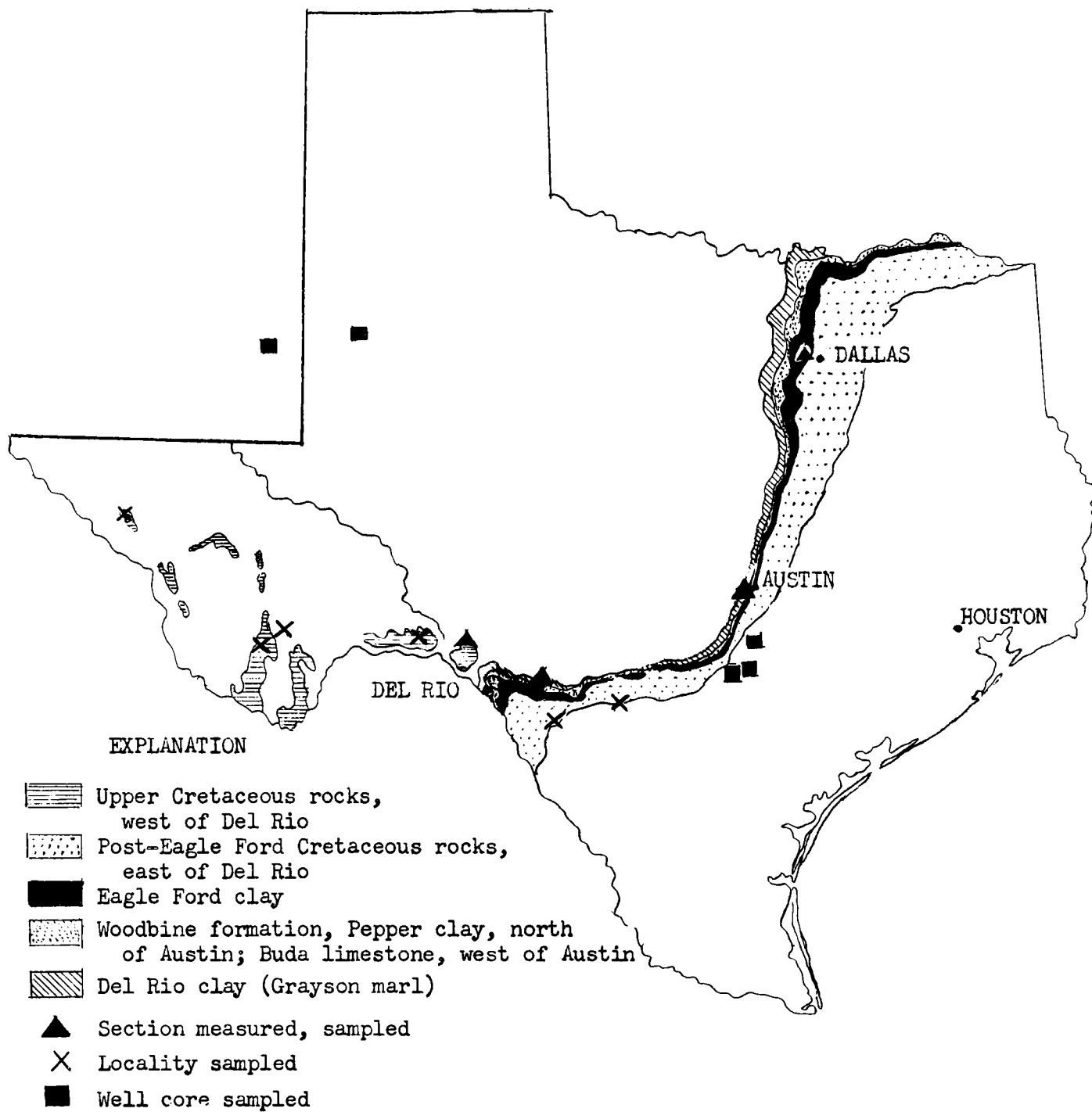

FIG. 32--MAP OF TEXAS SHOWING AREA OF CRETACEOUS OUTCROP PARTIALLY COVERED IN RECONNAISSANCE AND LOCALITIES SAMPLED.

bentonite, 0.002 percent on gray shale, and 0.002 percent on phosphatic limestone. West of the Pecos, the clays of the Eagle Ford contain as much as 0.003 percent eU, but with one exception contain less than 0.001 percent uranium. The exception is in the Buck Hill quadrangle in Brewster County, where a sample shows 0.001 percent eU and 0.002 percent U. Four samples of coal associated with tuffs and rhyolites in the Eagle Ford in the Eagle Mountains, Hudspeth County, average 0.002 percent eU, 24.82 percent ash, and 0.004 percent U in the ash. Tuffaceous (?) siltstones of the Eagle Ford in the vicinity of Del Rio average 0.001 percent eU and less than 0.001 percent U. Bentonites of the Eagle Ford in central Texas and just west of the Pecos River show from 0.002 to 0.004 percent eU and less than 0.001 percent U.

Dark gray clays of the Pepper clay underlying the Eagle Ford contain from 0.001 to 0.002 percent eU and less than 0.001 percent U. The Buda limestone underlying the Pepper clay, or Eagle Ford clay where the Pepper is absent, has 0.001 percent eU and less than 0.001 percent U. The Del Rio clay has an average of little more than 0.001 to 0.002 percent eU and in every case less than 0.001 percent U. Obviously the radioactivity of the Cretaceous formations east of the Pecos River is due to some other substance than uranium, probably K^{40} .

An asphalt dike along a fault in the Georgetown limestone underlying the Del Rio clay in central Texas shows less than 0.001 percent eU and U. Asphaltic sandstone in the Escondido formation, uppermost Upper Cretaceous, in Zavala County shows 0.001 percent eU. Clay of the Escondido formation, Medina County, shows 0.002 percent eU.

A sample of brown shale in the Maravillas chert, upper Ordovician, Marathon uplift, Brewster County, contains 0.004 percent eU and 0.003 percent U. Black shale of the Woodford formation from well cores in Terry County,

Texas, and Lea County, New Mexico, shows 0.005 and 0.004 percent eU respectively, but both show less than 0.001 percent U.

It is planned to measure several more sections, submit more samples showing higher radioactivity for eU and U analysis of the Eagle Ford clay, and complete the study of this formation in July 1954. The Del Rio clay will be studied in similar detail later.

Northern Rocky Mountain region
By W. J. Mapel

Formations containing black shale were examined for radioactivity at 87 localities in Montana and nearby states during the summer of 1953. (fig. 33). Beds of black shale contain at five of the localities visited 0.005 percent U or more (table 18).

The most uraniferous shale found during the investigation is a bed 8 feet thick at the base of the Brazer limestone of Upper Mississippian age, in Rich County, Utah. This bed contains 0.009 percent U in its upper part. The black shale sequence in which the bed occurs was examined elsewhere in northern Utah and southeastern Idaho, but no outcrops of comparable thickness and grade were found.

A thin bed of black shale at the base of the Madison limestone of Lower Mississippian age contains as much as 0.005 percent U in Gallatin County, Montana. Where examined at 12 other localities in southwestern and central Montana the uranium content of this unit ranges from 0.001 to 0.004 percent.

The "Bakken shale" of Lower Mississippian age consists of a sequence of black shale and sandstone or sandy limestone as much as 100 feet thick which underlies the Madison limestone or its equivalents in northeastern

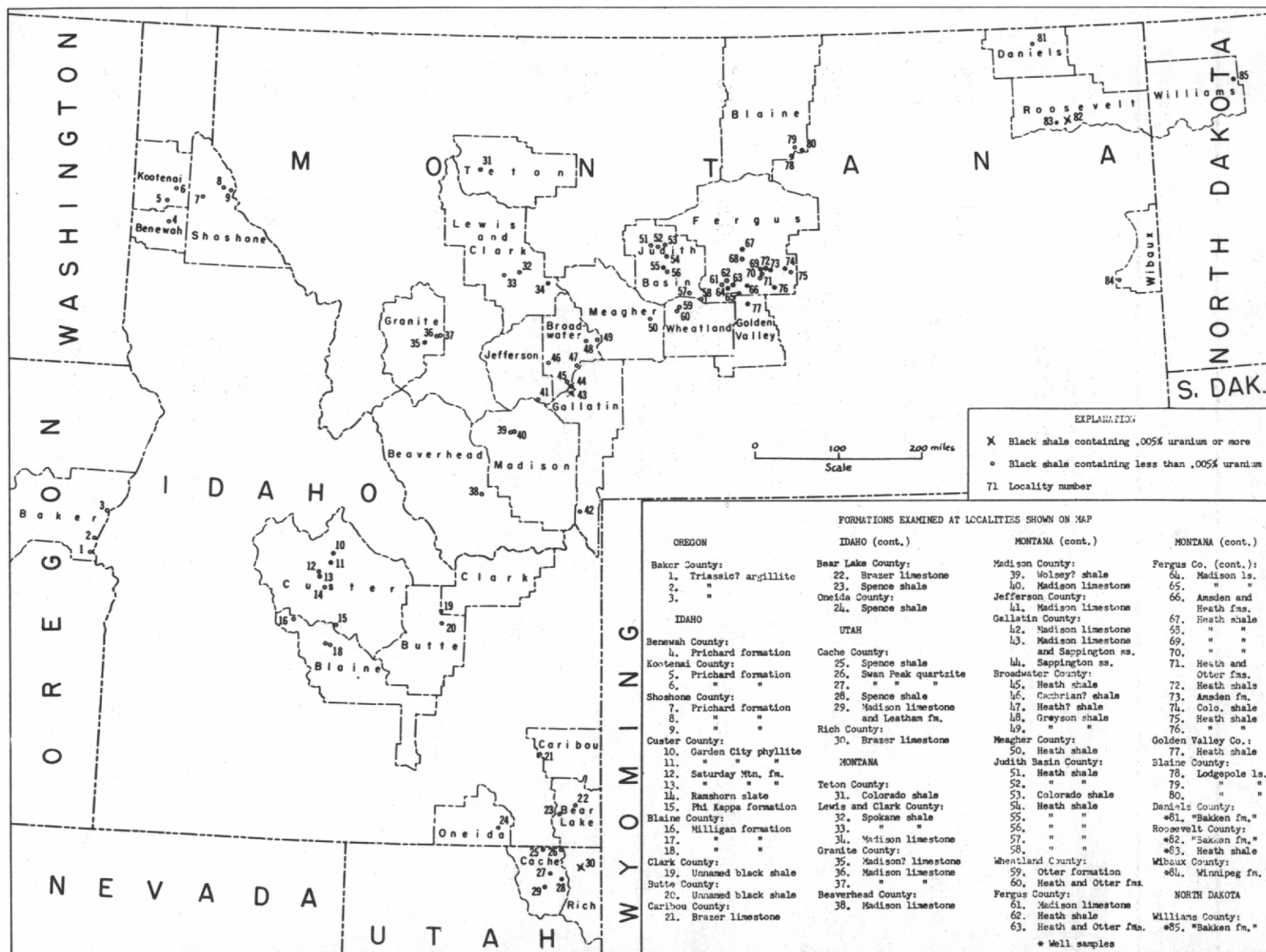

FIG. 33--INDEX MAP SHOWING BLACK SHALE LOCALITIES EXAMINED FOR URANIUM IN THE ROCKY MOUNTAIN REGION.

Table 18.—Uranium content of black shale at five localities
in the northern Rocky Mountain region

Location (Sec., Tp., R.)	Sample number	Description of the sample	eU percent	U percent
RICH COUNTY, UTAH (map loc. 33) 32-13N-6E	97019	Channel: middle 2' of 14' bed of dark brown shale; lower part of the Brazer limestone	.004	.006
GALLATIN COUNTY, MONTANA (map loc. 49) 25-2N-2E	97022	Grab: upper part of 8' bed of dark brown shale; base of the Brazer limestone	.004	.009
(map loc. 50) 2-2N-2E	94140	Channel: bottom 1.5' of 2.3' bed of black shale; base of the Madison limestone	.004	.005
ROOSEVELT COUNTY, MONTANA (map loc. 90) 2-28N-51E	94159	Channel: bottom 1' of 10' bed of dark brownish black shale; lower part of the Sappington sandstone	.004	.005
WILLIAMS COUNTY, NORTH DAKOTA (map loc. 92) 12-157N-95W	98518	Core chips: non-calcareous black shale; upper part of the "Bakken shale," depth 7165-7175', Murphy et al unit no. 1	.006	.006
	98520	Drill cuttings: non- calcareous black shale; upper part of the "Bakken shale," depth 9620-9630', Amerada Bakken no. 1	.004	.005
	98521	Drill cuttings: non- calcareous black shale; lower part of the "Bakken shale," depth 9700-9710', Amerada Bakken no. 1	.008	.007
	98522	Drill cuttings: non- calcareous black shale; lower part of the "Bakken shale," depth 9710-9720', Amerada Bakken no. 1	.009	.006

Montana and adjacent parts of North Dakota. Samples of drill cuttings from this formation contain as much as 0.007 percent U in Williams County, North Dakota. Gamma ray logs of wells that penetrate the "Bakken shale" are being studied to determine the distribution of radioactivity in the formation.

Goose Creek district, Idaho
By W. J. Mapel and W. J. Hail, Jr.

The beds of carbonaceous shale and lignite in the Goose Creek district are interbedded with volcanic ash, bentonite, greenish gray shale, sandstone, and conglomerate in two fairly well-defined zones in the lower part of the Salt Lake formation of early Pliocene age. The highest concentration of uranium is 0.010 percent in the upper part of a 5.4 foot bed of carbonaceous shale and lignite in zone B (fig. 34). The grade of carbonaceous beds found in the Barrett zone range from 0.044 percent to less than 0.003 percent U.

Reserves of uranium in the Goose Creek district in beds one foot or more thick containing 0.01 percent or more uranium are estimated at 120 short tons, of which 115 tons are in the Barrett carbonaceous shale zone (TEI-391, p. 30) and the remainder in Zone "B". Because of the lenticularity of the uranium-bearing carbonaceous beds, and the abrupt lateral changes in their uranium content, the reserves are regarded as inferred.

Chattanooga shale
By L. C. Conant

All of the cores taken by the Bureau of Mines in Tennessee and Alabama in 1953 have now been analyzed, and final reports of the work are nearly complete.

The outcrop of Chattanooga shale in much of Blount County, Alabama, has been mapped in detail at a scale of 1:24,000. During the next few weeks the shale in the folded areas of eastern Tennessee, northeastern Alabama, and northwestern Georgia will be visited. Outcrops will be measured, scanned, and studied in order to increase knowledge of the general conditions of accumulation of the shale. Further field studies are dependent upon the results of this reconnaissance.

Uranium in black shales
By Maurice Deul and I. A. Breger

A series of experiments to separate the organic and the inorganic material from the Chattanooga shale is underway. The purpose of obtaining such a separation is to determine whether the uranium is associated with the organic material or the inorganic material, and to obtain organic material of sufficient purity for characterization. Preliminary results indicate that in the Chattanooga shale the uranium is dispersed through the organic material but probably is not chemically combined with it. Two lines of evidence support this conclusion:

- (1) A concentrate of organic material obtained by ball mill grinding in mixed liquid media yields only 35.7 percent ash, compared to 75.5 percent in the original shale; yet this organic fraction contains only 0.0038 percent U as compared to 0.0090 percent in the original shale. Similarly the mineral concentrate from this same separation contains only 0.0049 percent U.
- (2) Fractionation of the shale by air elutriation shows that the uranium is concentrated in the finest fractions, which also

have a higher carbon and hydrogen content than the original shale, indicating an association of uranium with organic matter.

This evidence is not rigid proof of a theory. The colloidal-and near-colloidal-sized materials which were collected from the middlings of the ball mill grinding are being analyzed to determine if concentration has been effected in those sizes. Final results will be reported on a mass balance basis.

Similar studies are being conducted on uraniferous shales from near Gallup, New Mexico and from the Phosphoria formation. These shales contain approximately the same amount of organic matter as does the Chattanooga shale and a comparison of the modes of occurrence of the uranium in all three shales will yield a better understanding of the problem of the geochemistry of uranium in carbonaceous shales.

Asphaltite and petroleum

Asphaltic rocks in the western states
By W. J. Hail, Jr.

Uranium analyses have now been received for 14 of the 173 rock asphalt samples collected and submitted for uranium determination during the 1953 field season. Only three of the samples thus far analyzed contain significant amounts of uranium. These are listed below.

<u>Field No.</u>	<u>% Oil</u>	<u>% Ash in oil</u>	<u>% U in oil ash</u>	<u>Description and location</u>
HCA-36	7.01	0.46	0.035	Grab sample. Asphaltic sandstone, in lower part of 250' bed. About a mile south of Edna, San Luis Obispo Co., Calif.
HCA-38	29.20	0.22	0.033	Grab sample. Asphaltic siltstone, in middle of 20' bed. About 4 miles north of Casmalia, Santa Barbara Co., Calif.
HO-51	8.07	0.97	0.0125	Grab sample. Asphaltic sandstone in upper part of 30' bed. Near Asphaltum in northern Jefferson Co., Oklahoma.

Analyses of 35 samples of rock asphalt from California, Texas, Oklahoma, New Mexico, and Utah should be available by June 1.

Uranium analyses have recently been received for 2 samples of asphaltic sandstone from a quarry in Vernon County, Missouri. These are as follows:

<u>Field No.</u>	<u>% Oil</u>	<u>% Ash in oil</u>	<u>% U in oil ash</u>
HM-1	5.38	0.75	0.4
HM-2	4.08	0.70	0.013

Uranium in asphaltite and petroleum
By A. T. Myers

A total of 316 analyses were made on 268 samples of crude oil, asphaltites and petroliferous rocks. A distribution of these analyses is shown in tables 19 and 20.

Table 19.--Sample types analyzed

<u>Sample type</u>	<u>Number of samples</u>
Petrol. rock	182
Asphaltites	8
Crude oil	75
Miscellaneous	8
Total	<u>268</u>

1/ Spectrographic investigations were made on 113 of these samples in addition to above (reported under Spectrographic Methods Project).

Table 20.--Types and number of analyses

<u>Type of analyses</u>	<u>Number of analyses</u>
% Ash	268
% U in ash	24
% U (other than ash)	7
% Oil (in rock)	12
Miscellaneous	<u>5</u>
Total	316

To test the quality of our laboratory work a standard crude oil sample was ashed and analyzed by a quantitative spectrographic method. This sample previously had been analyzed by six different oil company laboratories. The results are in excellent agreement for the ash content, vanadium and nickel as shown in table 21:

Table 21.--Comparative analysis of a standard crude oil

(53-1593 Santa Maria Crude Oil* API(COAR))

<u>Detn.</u>	<u>PPM in the oil</u>	
	<u>Raw Materials Denver Spectrographic Laboratory</u>	<u>Six Oil Co.'s Laboratories (Averages)</u>
Ash	939	964
V	215	212
Ni	100	107

* Sample supplied by courtesy of A. Levin, Chairman of the Subcommittee on Trace Elements, API.

Work on this sample for other trace elements is still underway.

Arsenic occurs in several asphaltite samples in apparent association with uranium. Because of this association the peroxide bomb method (by Magnuson and Watson) for determination of arsenic was applied directly to

asphaltites. The following table shows the reliability of the method when it was applied to a group of rock samples. These samples were analyzed by three independent methods.

Table 22.--The determination of arsenic by three independent methods

<u>Sample No.</u>	<u>M e t h o d</u>		
	<u>Gutzeit 1/ percent</u>	<u>Peroxide Bomb 2/ percent</u>	<u>Spectrographic 3/ percent</u>
1	0.50	.35	.x (.2 to .5)
2	.6 to 1.0	.95	x.- (1.0 to 2.)
3	.05	.07	.ox (.02 to .05)
4	.03 to .08	.08	.ox (.02 to .05)
5	.08 to .1	.11	.ox+ (.05 to .1)
6	.9 to 1.5	1.33	x.- (1.0 to 2.0)

- 1/ H. McCarthy, analyst.
 2/ A. Horr, analyst.
 3/ Polly Dunton, analyst.

Studies are now underway to determine whether uranium and other metals are volatilized during dry ashing by the analysis of a selected group of crude oils and asphalts. A combustion tube furnace is employed in such a way that the volatile compounds are analyzed separately from the ashed residue to arrive at a total element balance.

The manuscript on "The association of uranium and other metals with crude oils, asphalts and petroliferous rocks" by R. L. Erickson, A. T. Myers, and C. A. Horr was reviewed and transmitted for publication in the Journal of the A. A. P. G.

The manuscript on "Some properties of porphyrins isolated from petroleum" by H. N. Dunning, J. W. Moore, and A. T. Myers was reviewed and sent to the Journal of Eng. and Ind. Chemistry for publication.

URANIUM IN PHOSPHATES

Northwest phosphate
By V. E. McKelvey

Work during the report period was concentrated on the preparation of reports for publication or open-file release. The following brief summaries give information on subjects not previously described:

Sections of the Phosphoria formation measured in 1953
By L. D. Carswell, R. W. Swanson, R. P. Sheldon, and T. M. Cheney

Brief rock descriptions and analytical data on 10 sections of the Phosphoria formation in Montana, Idaho, and Utah measured during the 1953 field season were assembled for open-file release. The most significant data are those from Sugar Pine Creek, Rich Co., Utah, where 15.4 feet of continuous section was found to contain 30.2 percent P_2O_5 . Within this section a zone 9.0 feet thick averages 32.3 percent P_2O_5 .

Interpretation of data on the uranium
content of the Phosphoria formation
By E. R. Cressman and L. D. Carswell

Preliminary investigations of the relationships between uranium and equivalent uranium in the Phosphoria formation in Montana and southeastern Idaho (aimed at analysis of regional trends in uranium content and the relations of uranium to other constituents and to weathering) indicate a difference in the ratio of eU to U for those samples analysed in 1949. To test this difference in the ratio of eU to U, samples were selected randomly from all analyses made each year since the project's beginning. Statistical analysis of these data by the method of covariance disclosed significant differences in the analyses made in later years from those made

in earlier years. Before apparent areal variations in uranium content and local variations in eU/U can be examined further, a randomly selected group of samples must be reanalyzed to see if the differences in the uranium content disclosed by this study are actual or are due only to changing analytical techniques.

Selenium in the phosphatic members
of the Phosphoria formation
By R. A. Gulbrandsen

Analyses for selenium have been made on 118 samples of phosphatic and non-phosphatic rock from the phosphatic members of the Phosphoria formation. The samples were selected at localities scattered over the western phosphate field.

The selenium content for all samples ranges from about 0.0001 percent to about 0.03 percent, and the average content is about 0.0045 percent. On the average, samples of very high phosphate content contain less selenium than those very low in phosphate--43 samples containing more than 30 percent P_2O_5 have an average selenium value of 0.0028 percent, and 30 samples containing less than 5 percent P_2O_5 have an average of 0.0068 percent selenium. However, a 6.4-foot zone of high-grade phosphate rock (greater than 30 percent P_2O_5) at Mable Canyon, Idaho, contains, as an average of 6 samples, more than 0.01 percent selenium, a group average that is one of the three highest among all the sampled zones.

The other two groups of samples of high selenium content are composed of rock of very low phosphate content but of high organic content, one high in carbonaceous matter and the other high in oil content.

The group of five samples with high content of carbonaceous-matter is from a 3.8-foot zone at Coal Canyon, Wyo., and contains more than 0.01 percent selenium in addition to 0.7 percent V_2O_5 .

The petroliferous group of samples is from the oil shale of the D-member at Sheep Creek, Mont. Eight samples of the oil shale with an average oil content of 5.4 percent contain more than 0.01 percent selenium.

Southeast phosphate

Exploration
by W. L. Emerick

Company drilling

The following drilling on land to be mined prior to 1965 was carried out by phosphate companies, on their own property, under contract with the AEC:

	<u>Holes drilled</u>		<u>Footage</u>		<u>Contract:</u>
	<u>Last Report</u>	<u>Total to date</u>	<u>Last report</u>	<u>Total to date</u>	<u>Percent completed</u>
American Agricultural Chemical Co.	43	141	1,740.5	4,785.0	100
American Cyanamid Company	0	93	0	3,293.0	62

Samples from the aluminum phosphate and calcium phosphate zones were collected from drill holes by the companies for analyses of U, P_2O_5 , Al_2O_3 , and CaO. All of the holes on AEC contracts with the companies are logged by the Geological Survey's gamma-ray logging unit.

The warehouse for storage of company prospect samples is being closed and stored samples to be analyzed for U are being shipped at a rate of about 1,000 samples per month to the Washington laboratory.

Geologic drilling

A recalculation of the total footage drilled on this completed program showed a total of 115 holes for a footage of 7,112.0 feet.

Mobile drilling

A Mobile drill was used during December and January for exploratory drilling to delimit zones of aluminum phosphate. The drilling was discontinued in February to await results from contract drilling programs.

Radiometric logging of drill holes

A total of 318 holes aggregating 12,088.4 feet were logged by the gamma-ray unit. The cumulative total for the gamma-ray unit is 3,289 holes totalling 117,276.8 feet.

Economic geology, land-pebble phosphate field By J. B. Cathcart

Much of the available information on the aluminum phosphate zone of the land-pebble phosphate district was compiled during the report period. A report (TEI-394), transmitted in January 1954, summarized the information on the Peace Valley area in the eastern part of the district, and maps showing the distribution, thickness, and uranium and phosphate content of the aluminum phosphate zone for the entire district are being prepared.

Although the data are less abundant in the western part of the area, the general distribution of aluminum phosphate material seems to be the same as in the Peace River area; that is, the most continuous, thickest, and highest grade material underlies the flanks of the ridges and the flatwoods adjacent to the ridges, with the material absent in the valleys of the major streams, and thin and discontinuous on the ridges.

Studies of the relations between uranium, phosphate, calcium, and aluminum are continuing. Pearsonian coefficients of correlation were calculated to express quantitatively the P_2O_5 -Uranium relationship. The coefficient can vary from +1, (perfect positive correlation) through 0 (no correlation) to -1 (perfect inverse correlation). Grouped samples from eleven mining areas show positive correlations ranging from +0.11 to +0.80. These studies will be continued, using all available data and will be extended to consider relations between uranium and CaO , Al_2O_3 , and F.

Tonnage and grade computations for the uranium content of the aluminum phosphate zone are nearly completed. Most of the data were derived from gamma-ray logs.

Geology of the north and east edges of the
land-pebble phosphate district
By K. B. Ketner and L. J. McGreevy

A report on the Cenozoic stratigraphy in an area extending from Hernando to Hardee Counties (fig. 35) is nearly complete. Exact descriptive logs were made in 6 mines and 54 cored drill holes of all beds between the surface and bedrock. More than 200 samples from mines and cores were dried, weighed, washed free of silt and clay and leached of phosphate and other solubles. Median diameters and percentage weights of the remaining pure quartz sand were measured and plotted on stratigraphic sections with other data. This technique brought out unsuspected continuity and order in previously enigmatic beds of clays and sands. Measurements of quartz sand were helpful in relating weathered rock to parent rock because quartz resists weathering.

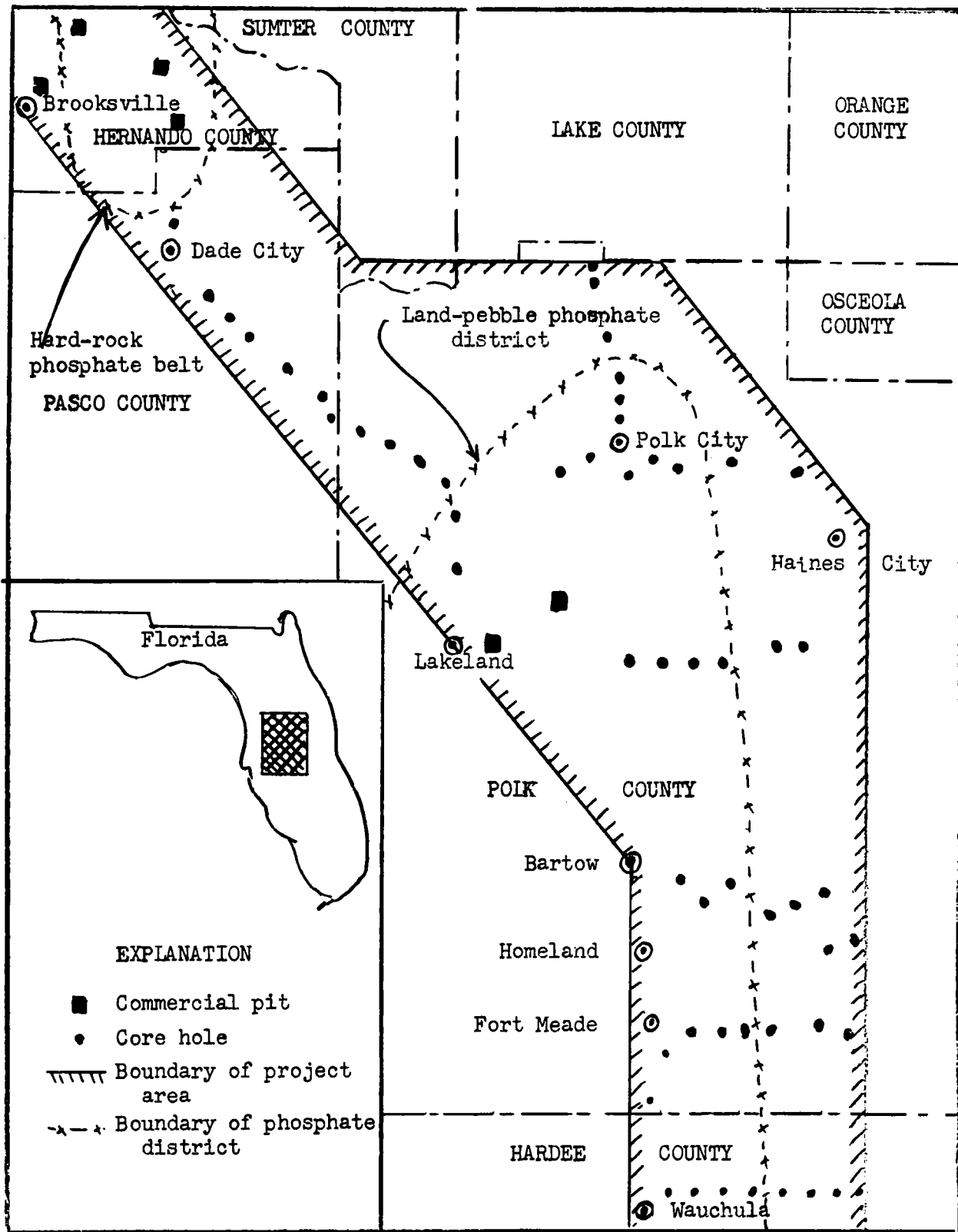

Figure 35.-Sketch map of central Florida showing north and east edges of the land pebble phosphate district

The formations listed in table 23 were identified in the report area. In the southern part of the hardrock phosphate belt, phosphate deposits occur in three Miocene units: (1) Hawthorn formation, sand phase, (2) Tampa formation, clay phase, and (3) Tampa formation, phosphorite phase.

In the northern part of the land-pebble phosphate district, phosphate deposits occur in two Middle Miocene units: (1) the Hawthorn formation, sand phase, and (2) the Hawthorne formation, phosphorite phase.

The Alachua and Bone Valley formations of late Miocene or Pliocene age were not recognized in the report area.

Stratigraphy of middle Tertiary rocks
in part of west-central Florida
By W. J. Carr and D. C. Alverson

Field work

In January and February 1954, sampling of sections and refinement of mapping in critical areas were completed. New typical sections containing diagnostic fossils were found for parts of the Tampa limestone and Hawthorn formation. An attempt was made to carry the known stratigraphy on the fringes of the nodular phosphate district into the district itself. Field conferences were held with geologists who are working on similar problems in the Coastal Plain.

Three members of the Hawthorn formation are recognizable: a limestone member, a phosphate member and a sand member. A clayey sandy part of the Tampa limestone was also found to be mappable. These subdivisions of the Tampa and Hawthorn formations are severely weathered and it is usually impossible to determine whether or not the original rock was a limestone. In figure 36 the sand and phosphorite members of the Hawthorn formation are mapped together. One or both of these lithologic units may be present at a

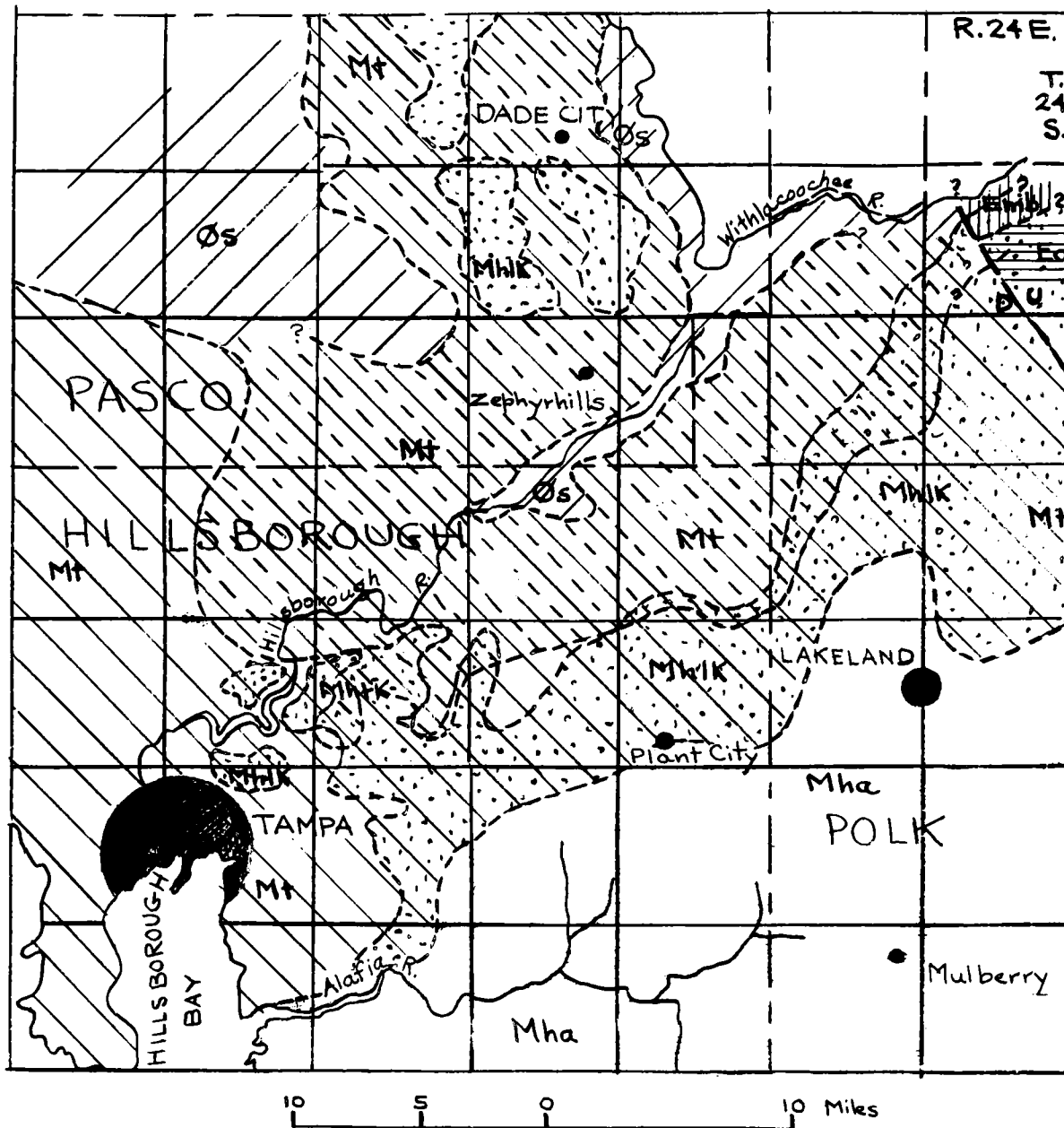

FIG. 36--GEOLOGIC MAP OF PART OF WEST-CENTRAL FLORIDA, POST MIDDLE MIOCENE REMOVED.

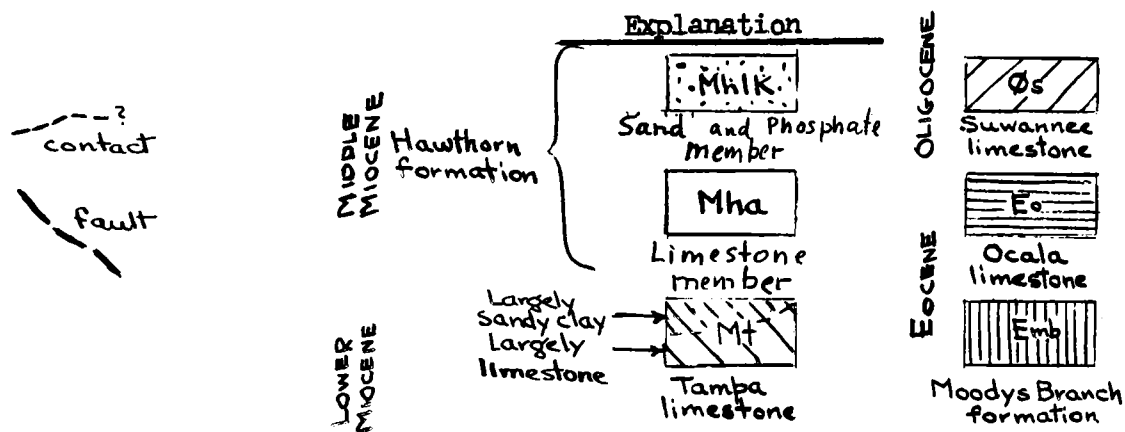

Table 23.—Formations recognized between Hernando and Hardee Counties, Florida

Epoch	Formation, northern part of project area	Formation southern part of project area	Description
Upper Miocene		sand	Medium to very fine quartz sand and mica loosely cemented with clay
Middle Miocene	Hawthorn formation, sand phase ^{1/}	Hawthorne formation, sand phase	Fine quartz sand loosely cemented with clay and aluminum phosphates (aluminum phosphate zone in places)
Middle Miocene		Hawthorn formation, phosphorite phase	Quartz sand, mainly fine, clay, and phosphorite nodules (the "matrix" or calcium phosphate zone)
Middle Miocene		Hawthorn formation	Limestone containing fine to medium quartz sand, clay and phosphorite nodules
Lower Miocene	Tampa formation, clay phase	Tampa formation	In the north, clay containing very fine to fine quartz sand; in the south, limestone containing quartz sand, clay, and phosphorite nodules
Lower Miocene	Tampa formation, phosphorite phase		Soft apatite containing particles of hard apatite, very fine to fine quartz sand, and clay (hardrock phosphate deposit)
Upper Oligocene	Suwannee limestone		Limestone containing very fine quartz sand
Upper Eocene	Ocala limestone	Ocala limestone	Pure limestone

^{1/} The term "phase" is used where there is evidence that the lithologic unit referred to is of secondary origin rather than a primary depositional unit

given point. The two members are not shown as overlying the limestone member of the Hawthorn formation, but they are locally present there beneath the Bone Valley formation of upper Miocene or Pliocene age.

Laboratory and office work

Determination of the characteristics of quartz sand in calcareous and non-calcareous rocks was completed for over 300 samples of rocks from Eocene to Miocene in age. About two-thirds of the samples are calcareous, and solution in acid was necessary to obtain a residue for mechanical analysis. Although results are not completely tabulated, slight but consistent differences in sand size and clay and sand ratios were observed for the formations. The data will be useful in working out the correlation and geologic history of the sediments.

Heavy minerals were separated from over 100 samples of sand derived from mechanical analysis. It is hoped that examination of the heavies will support mechanical analysis data.

Examination of 45 thin sections of limestone, chert, and secondarily cemented material yielded additional information on the textures of these rocks and their alteration products.

A summary of results of chemical analyses of limestone is given below.

Table 24.--Analyses of Tertiary limestones, west-central Florida

	Percent		
	Suwanee limestone 7 samples	Tampa limestone 16 samples	Hawthorn fm., limestone member 27 samples
P ₂ O ₅	0.2	0.3	2.0
CaO	48.93	47.49	28.81
Al ₂ O ₃	0.3	1.2	1.0
Fe ₂ O ₃	0.28	0.41	0.49
MgO	0.42	0.82	14.70
eU	<0.001	<0.001	0.001

The low P₂O₅, Al₂O₃, and eU contents, particularly of the Hawthorn (limestone member), are unexpected in view of the concentration of these compounds in overlying deposits derived from the Hawthorn. The difference in calcium and magnesium contents in the Tampa and Hawthorn are of interest because they may reflect a difference in the clay mineralogy of the two formations.

Stratigraphy of parts of Hardee and De Soto Counties, Florida
By M. H. Bergendahl

The late Cenozoic stratigraphy of that part of central Florida immediately south of the land-pebble phosphate district was studied in detail to determine the southern limit of the economically important Bone Valley formation and its relations with marine rocks of late Miocene and Pliocene age in south-central Florida. In addition, a reconnaissance appraisal was made of the phosphate and uranium resources of this area. Mapping of the upper Tertiary and Quaternary rocks, including a generalized consideration of the economic geology, was completed.

The Hawthorn formation, of middle Miocene age, is the oldest rock exposed. Undifferentiated phosphorite of Upper Miocene and Pliocene age, includes residuum of either weathered Hawthorn formation or Bone Valley formation, or both. This phosphorite interfingers with an unnamed marine sand of Upper Miocene age. The Caloosahatchee marl, of Pliocene age, is present in the southeast corner of the area. Pleistocene deposits consisting of stratified clayey sand and sand containing scattered thin lenses of fresh water limestone and marl are also present. These sediments are either floodplain deposits or subaerial topset beds of a delta made by the Pleistocene Peace River. Sediments of Recent age are predominantly local stream deposits, including accumulations of "river-pebble" phosphate.

Bars and shoals in the Peace River south of Brownville, De Soto County, contain appreciable tonnages of low grade "river-pebble" phosphate. The phosphate and uranium content of the undifferentiated phosphorite in Hardee County is so low that it is doubtful whether any large ore bodies exist. Economic concentrations of phosphate are not present in the unnamed Upper Miocene sand, Caloosahatchee marl, or the Pleistocene deposits.

Occurrence of uranium in phosphate deposits
By Z. S. Altschuler, R. S. Clarke, Jr., and E. J. Young

Geochemistry

Previous work indicated that uranium in unaltered phosphorite occurs as a structural replacement of calcium in apatite. If so, the uranium should be present as U^{+4} which has an ionic radius virtually identical with that of calcium. Accordingly, a variety of samples of igneous apatite, bone, and sedimentary apatite have been analyzed for total and tetravalent uranium content. Two methods of analysis were adopted after appropriate

checks with spiked samples of synthetic, uranium-free apatite to insure (a) that tetravalent uranium is unchanged during solution; (b) that hexavalent uranium is not reduced in the course of analysis; and (c) that the recovery of tetravalent uranium is complete.

The methods are precipitation of uranous cupferrate with titanium cupferrate and precipitation of uranous oxalate after digestion in oxalic acid. Some of the results are given in the table below:

Table 25.--Analyses of apatite for tetravalent and total uranium

<u>Sample</u>	<u>% U</u>	<u>% U⁺⁴ by cupf. pptn.</u>	<u>% of U as U⁺⁴ in cupf. pptn.</u>	<u>% U⁺⁴ by oxalic acid pptn.</u>	<u>% of U as U⁺⁴ in oxalic acid pptn.</u>
Igneous fluor- apatite Durango, Mexico	0.0010	0.0005	50	0.0009	90
Sedimentary carbonate-fluor- apatite, Bone Valley fm., Florida (B.L.-3, 2-18-49)	0.016	0.012	75	0.015	94
Sedimentary carbonate-fluor- apatite, Bone Valley fm., Florida (B.L.-1 (O.O.M.))	0.011	0.0085	77	0.0098	89

The oxalic acid precipitation values are regarded as more accurate. Additional analyses reveal a greater range in U⁺⁴ content; however, in all but one of the samples studied the U⁺⁴/total U ratio was greater than one. As U⁺⁴ oxidizes easily to U⁺⁶ even slight weathering (which these materials have undergone) would change the original U⁺⁴ content. The tentative conclusion is that initially the uranium in apatite was U⁺⁴ and that any U⁺⁶ found is secondary.

Petrology

Studies of quartz sand from the Bone Valley formation and a five foot section from the Hawthorn formation show that quartz in the Hawthorn formation is less rounded and more uniform than that in the Bone Valley.

The upper Bone Valley formation, where not apparently leached or altered, is generally a kaolinitic quartz sand. In the lower Bone Valley most of the clay is montmorillonite. Upon alteration the montmorillonite grades into kaolinite. This suggests that the upper kaolinitic sand, although apparently fresh, may be leached and altered. Specimens from many localities have been studied by X-ray and found to contain minor amounts of montmorillonite. From this it may be supposed that the montmorillonite-to-kaolinite alteration is one of the earliest paragenetic stages in the history of the aluminum phosphate (leached) zone.

Field studies.

Study of mottling and weathering profiles in the Land Pebble district has produced evidence at several localities of successive waves of weathering. Earlier weathering of a lateritic type exists in the form of ferruginous hardpan and nodular encrustation in the clayey sands of the upper Bone Valley formation. Where ground-water podzols occur or where root penetration is important, preexisting lateritic zones are destroyed or lowered by removal of iron oxides. One result of these weathering cycles is to increase the thickness of the loose quartz sand mantle of the region.

The so-called Pleistocene sand mantle in the Land-Pebble field varies little in size or sorting characteristics across the region. In an unmined area a body of coarser sand was located on the flanks of the main

topographic high in the area. Samples were collected around and across this deposit to outline its extent and its rate of change to the relatively undifferentiated sands of the surrounding region. Such information may shed light on source areas and directions of deposition.

URANIUM IN PLACER DEPOSITS

Southeastern monazite exploration

By W. C. Overstreet

Since December 1953 the following work was completed:

1. Drafting 1:20,000-scale planimetric maps of monazite-bearing streams between the Savannah and Catawba Rivers, S. C.-N. C.; a total of 44 maps.
2. Photographic reduction of the planimetric maps.
3. Computing, drafting, and photographic reduction of 12 heavy-mineral isogram maps for the area between the Savannah and Catawba Rivers, S. C.-N. C. Final scale 1 inch to 4 miles.
4. Drafting and reduction of four index maps between the Savannah and Catawba Rivers. Final scale 1 inch to 4 miles.
5. Drafting and reduction of a geologic map, sample distribution map, and five heavy-mineral isogram maps of Knob Creek, Cleveland Co., N. C. Final scale is 1:24,000.
6. Computing, drafting, and reduction of triangular diagrams showing grain-size distribution in alluvial heavy minerals.
7. Computing and tabulating areas and volumes of flood-plain sediments on all monazite-bearing streams between the Savannah and Catawba Rivers.
8. Computing and tabulating tenors of samples between the Savannah and Catawba Rivers.
9. Computing and tabulating inferred reserves of monazite in streams between the Savannah and Catawba Rivers.

10. Miscellaneous drafting, calculations, and tabular work to complete the areas between the Yadkin and Dan Rivers, N. C.-Va., and the Oconee, Flint, and Chattahoochee Rivers, Ga.

In late April work began on a summary text to integrate tables and maps.

The distribution and tenor of the placers can be generalized as follows: monazite is widely distributed and widely dispersed in streams in the western Piedmont of Virginia, North Carolina, South Carolina, and Georgia. It is most concentrated in the headward parts of the streams where continuous flood plains rarely exceed 1 million cubic yards in volume. In that environment the alluvial sediments contain as much as 8 pounds of monazite per cubic yard. Downstream, where flood plains reach as much as 60 million cubic yards in volume, the tenor in monazite drops to a few tenths of a pound per cubic yard.

Central Idaho Placers

By J. H. Mackin and D. S. Schmidt

During the period December 1, 1953--May 31, 1954 work on the Central Idaho Placer project has been confined to the laboratory at the University of Washington and includes completion of quantitative mineralogic analysis of about 2,000 heavy mineral (pan) samples; study of about 150 thin sections in connection with the occurrence of radioactive minerals in the rocks of the Idaho Batholith; and preliminary drafting of final maps and sections. The laboratory work reduces to quantitative terms the qualitative conclusions outlined in preliminary reports (TEM-473, 602).

Wet Mountains, Colorado

By R. A. Christman, M. R. Brock, and Q. D. Singewald

The reporting period was devoted mainly to map compilation, petrographic study of about a hundred thin sections, and report writing. A report to be completed about July 1 will cover the results of all detailed mapping and give brief descriptions of several properties outside the mapped area.

More than 350 thorium-bearing veins were discovered within a 22-square mile area on the west flank of the Wet Mountains (fig. 37), where geologic mapping has been completed at a scale of 1:6,000. The larger veins and the more important individual localities are shown on figure 38.

Thorium occurrences seem unrelated to changes in strike or dip of the veins. With the exception of one deposit (the General Ike), the thorium concentrations do not seem to occur at vein intersections. The surrounding country rock apparently was not a major influence on thorium deposition, as high-grade deposits are found in both siliceous and mafic rocks. There appears, however, a slight affinity of thorium for silica-rich country rocks and silicified parts of veins. The thorium province is continuing to attract the attention of prospectors and lessees, and many new claims and leases have been recorded in the last 6 months.

An age determination by the Larsen (zircon) method of an albite syenite stock in the mapped area shows the rock to be about 623 million years old, or late pre-Cambrian in age. This stock post-dates all other intrusives with the possible exception of one or two types of dikes. Although the thorium veins are younger than the albite syenite stock, they may be genetically related to it, for the stock has an unusually high thorium content.

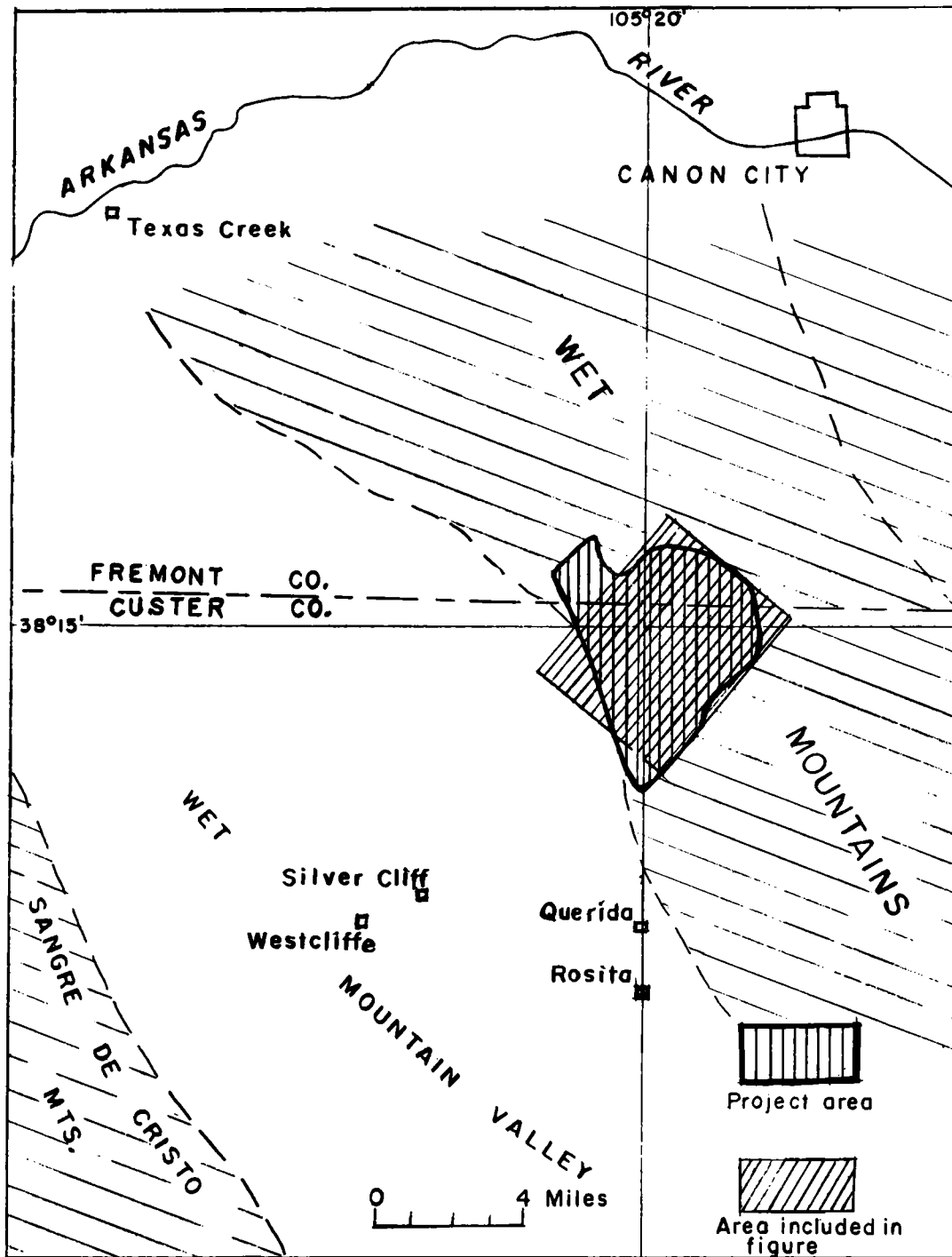

FIG. 37--SKETCH MAP OF WET MOUNTAINS AREA, CUSTER AND FREMONT COUNTIES, COLORADO.

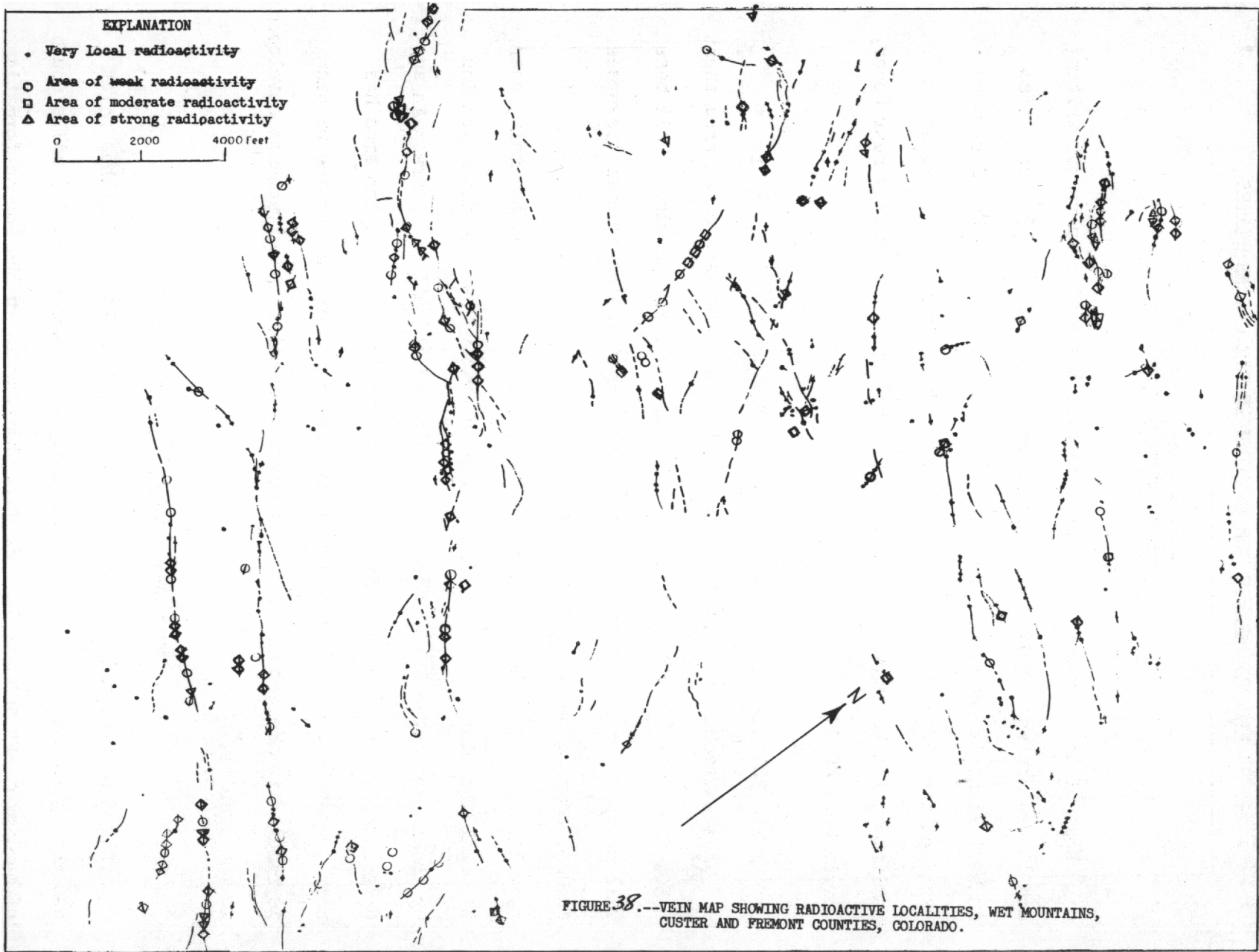

FIG. 38--VEIN MAP SHOWING RADIOACTIVE LOCALITIES, WET MOUNTAINS, CUSTER AND FREMONT COUNTIES, COLORADO.

RECONNAISSANCE FOR URANIUM IN THE UNITED STATES

Northeast district
by F. A. McKeown

Most of this report period was spent in the office on report writing and laboratory work. During several weeks of field work, 34 localities in West Virginia, Maryland, Pennsylvania, New Jersey, and New York were examined for radioactivity; significant radioactivity was noted at Marlinton, Pocahontas Co., W. Va., and at the Hibernia anomaly near Dover, Morris Co., N. J.

Phillips mine area, Putnam and Westchester Cos., N. Y.

A topographic base map on a scale of 1:2400 was made of an area about 4,500 feet by 1,800 feet in the vicinity of the Phillips mine. This base will be used for recording dip-needle and scintillation-counter traverses and for mapping the geology during the summer.

Zircon from hornblende granite that crops out on Mine Mountain, near the Phillips mine, was submitted to the laboratory for age determination by the Larsen method. The age was reported as 620 million years. An age determination for the uraninite in the mineralized zone of the area has been requested. Comparison of the two ages may show whether the uranium is related to the granite or to later mineralization in structures developed in the granite.

Marlinton, Pocahontas Co., W. Va.

A bed of radioactive sandstone and siltstone 18 to 30 inches thick and more than 300 feet long, occurs along U. S. Route 219, 1.3 miles south of Marlinton, Pocahontas Co., W. Va. The rock is in the Pocono formation

of Mississippian age. Samples of the sandstone contain from 0.002 to 0.022 percent eU and from less than 0.001 to 0.011 percent U. One sample of the sandstone is estimated to contain about 2.6 percent of heavy nonmagnetic minerals, most of which are zircon. These data suggest that the zircon and possibly other thorium-bearing detrital minerals may contain the bulk of the radioactive elements in the rock.

Hibernia anomaly, Morrison Co., N. J.

Limonite-stained radioactive gneiss occurs in the open-cut at the Hibernia anomaly, about 3 miles north of Dover, Morris Co., N. J. Most of the gneiss is decomposed to a friable mass of quartz, feldspar, and limonite. The radioactive zone ranges from 5 to 9 feet wide and is more than 200 feet long; the radioactivity ranges from 0.05 to 0.45 mr/hr, averaging about 0.08 mr/hr. The zone is part of the low-grade disseminated magnetite ore body that was explored recently by stripping.

Uranium occurrences in Bucks Co., Pa., and Hunterdon Co., N. J.

Assays of samples show that the radioactive argillite in the Lockatong lithofacies, of Triassic age, commonly contains from 0.005 to 0.01 percent U. The radioactive sandstone in the Stockton lithofacies of Triassic age commonly contains from 0.01 to 0.03 percent U.

Comparison of the lithologic and mineralogic characteristics of these occurrences with similar occurrences elsewhere in the world suggests that neither the Lockatong nor the Stockton lithofacies is likely to contain high-grade uranium deposits.

South-central district
by E. P. Beroni

Texas

A radioactive fresh-water limestone was discovered 26 miles south of Alpine, Brewster County, Texas, in the Pruett formation of the Buck Hill volcanic series of Tertiary age. The series consists of interbedded tuffs, breccia conglomerates, and fresh-water limestone that in many places forms the cap rock. This limestone is exposed for a distance of approximately 8 miles; it is lenticular, ranging from a knife-edge to 8 feet in thickness. Where examined, the bed is 3 feet thick and contains 0.012 percent eU.

In Fisher County, 12 miles northwest of Sweetwater, a 5-foot thick bed of radioactive micaceous siltstone containing carbonaceous flakes was found. The siltstone contains 0.018 percent eU and 0.027 percent U. The carbonaceous flakes, floated off by mechanical separation, contain 0.32 percent eU and 0.63 percent U. The deposit is in a small channel or lenticular body approximately 75 feet wide and 5 feet thick, cut in a yellow friable sandstone of the Dockum group of Triassic age. A sandstone member of the Dockum group in southern New Mexico contains small amounts of carnotite.

In the Llano Uplift area, pegmatites were discovered that contained up to 0.06 percent U. The majority of these pegmatites, however, are thorium-bearing. No significant uranium deposits have been found in the area to date.

Arkansas

Airborne reconnaissance by the AEC picked up 5 anomalies in the Magnet Cove area, and 2 anomalies in dikes that cut the Paleozoic sediments near the intrusion. The anomalies in the Magnet Cove area are confined to rutile-bearing veins near the contact of the igneous complex and the Paleozoic sedimentary rocks, and highly altered iron-stained meta-sediments and sediments in the contact zone.

Geochemical and radioactivity work continued on the Wilson's Potash Sulphur Springs deposit in sec. 17, T. 3 S., R. 18 W., Garland County. The greatest radioactivity seems to be on the north and south sides of the igneous complex, near the contact with the Paleozoic sediments. Samples collected to date from the south side of the intrusion contain 0.005 to 0.4 percent U. Geochemical samples of the soil in the radioactive area show a niobium content of 400 to 30,000 ppm, and a vanadium content of 0.2 to 2.0 percent.

Most of the geochemical sampling and radioactivity work was done in the vicinity of the bulldozer cuts on the east side of the igneous complex, where the University of Arkansas did the larger part of their radioactivity and geologic work. Here the niobium content ranges from a 100 to 20,000 ppm and the vanadium from 0.05 to 2.0 percent. The uranium content on channel samples ranges from 0.004 to 0.2 percent. Radioactivity and geochemical results to date indicate that the best niobium and uranium mineralization occurs northwest of the bulldozer cuts. This soil-covered potential ore body is approximately 300 feet long and 250 feet wide. Additional hand augering will be done to determine if any fresh samples can be obtained for mineralogical and chemical tests.

One sample of saprolitic material from the south side of the igneous complex contains apatite and an unidentified uranium-niobium mineral, which, with other heavy minerals, makes up approximately 30 percent of the sample.

One water sample from a churn drill hole on the east side of the igneous complex contained 162×10^{-12} C/L uranium, and 72×10^{-12} C/L radium. The uranium-radium content shows that the water may either be a mineralizer or a leacher. Additional water sampling will be done in the Wilson's-Magnet Cove area next fiscal year to determine what part the ground water plays on the saprolitic material.

Preliminary analyses of an asphaltic sandstone sample collected in sec. 35, T. 17 N., R. 26 W., near Huntsville, Madison Co., show 2.51 percent oil, 1.11 percent ash, 12 ppm U in oil, and 0.11 percent U in the ash. The asphaltic material occurs in a dark-brown coarse-grained sandstone of the Pennsylvanian Hale formation. This formation is overlain by the mildly radioactive Pennsylvanian Bloyd shale, samples of which contained up to 0.009 percent equivalent uranium. A fresh exposure of the asphaltic material in the sandstone is fresh appearing and plastic. It is significant that deposits of uraniferous asphaltic material have been found on three sides of the Ozark Dome: this deposit on the south, an albertite deposit on the east, and a tar seep in the Picher field zinc mines on the west. The best analyses of the oil ashes contains 0.11, 3.79, and 0.072 percent U, respectively.

Oklahoma

Seventeen channel samples from the Lee Uto uranium prospect, Pawnee Co., contain from 0.002 to 0.068 percent eU. The highest radioactivity

is confined to sulfide-bearing carbonaceous material and coal. This deposit is one of many that show an association of radioactivity with secondary copper-bearing minerals in the Permian red beds of Oklahoma.

North-central district
by R. C. Vickers

Nepheline syenite complex, Marathon County, Wisconsin

An airborne reconnaissance of about 12 square miles was completed. All the anomalies found outside an area underlain by nepheline syenite were related to concentrations of thorium-bearing minerals in residual soil. Most anomalies in the area underlain by nepheline syenite were due mainly to the mass effect of large areas of slightly radioactive syenite and nepheline syenite. The location of the anomalies and thorium mineral occurrences are shown in figure 39. Localities numbered 3, 4, 5, and 6 were found by the airborne work, and localities 1, 2, and 7 were detected by ground traversing during the preceding report period. There are no outcrops in the area of the mineral occurrences.

Shallow trenching and channel sampling were completed in the areas of two anomalies (localities 1 and 2). Channel samples totalling 12 feet in length at locality 2 contained 0.21 percent thorium, and channel samples totalling 5 feet from locality 1 contained about 1 percent thorium. The depth and lateral extent of these occurrences are unknown.

McCutcheon Creek uranium occurrence, Iron County, Michigan

In Sec. 35, T. 45 N., R. 32 W., Iron Co., Mich., small primary (?) concentrations of uranium were found in granite gneiss. A secondary

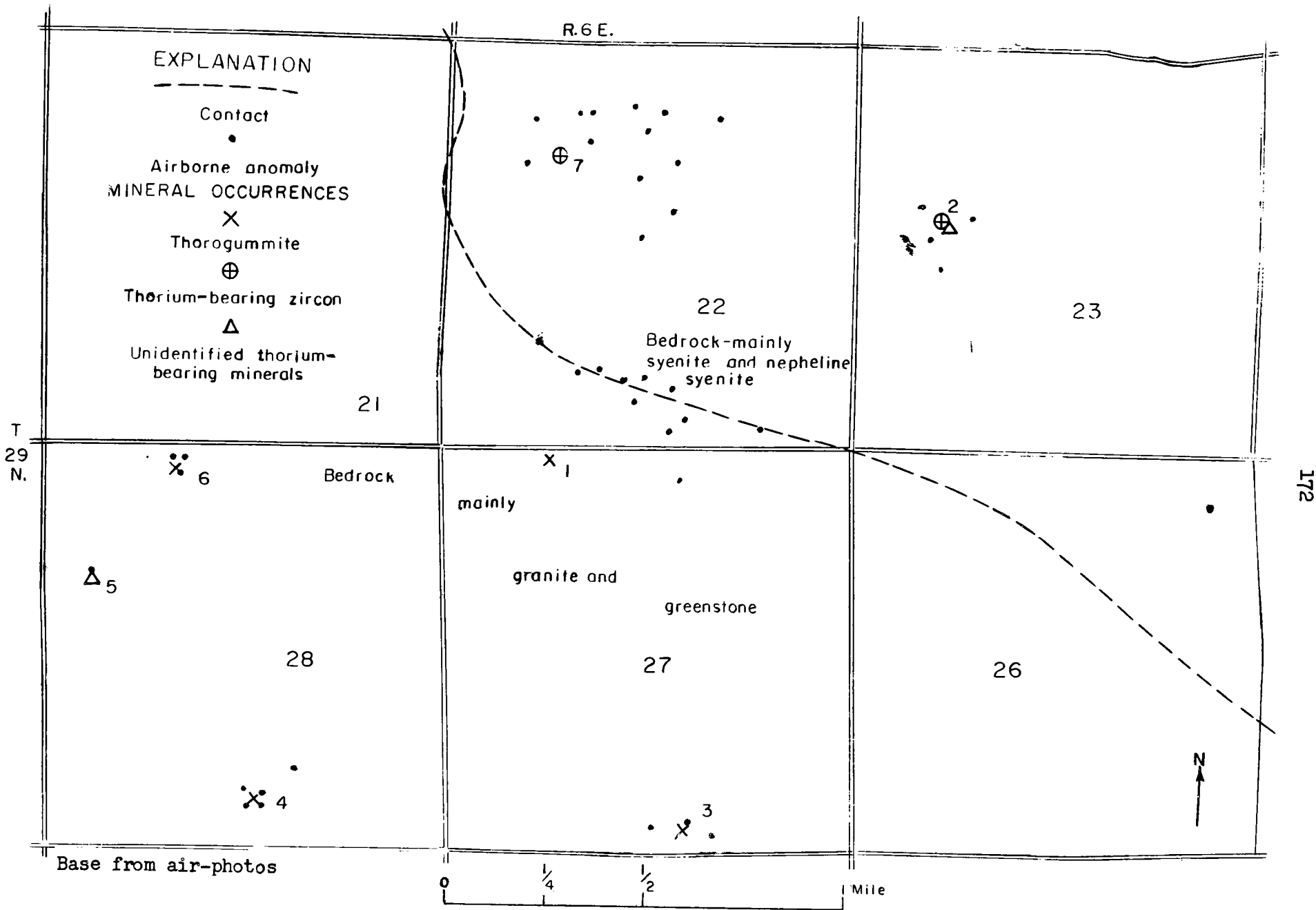

FIG. 39--MAP SHOWING LOCATION OF AIRBORNE ANOMALIES AND THORIUM-MINERAL OCCURRENCES NEAR WAUSAU, MARATHON COUNTY, WISCONSIN.

uranium mineral, coating fractures in the gneiss, was identified as rutherfordine (UO_2CO_3). Granite and granite gneiss in the area are abnormally radioactive, and local high scintillation counts were detected over an area of outcrop of several acres in extent. Further work will be done in the area during the 1954 field season. Additional localities of abnormal radioactivity reported by prospectors in the vicinity of the McCutcheon Creek occurrence will also be investigated.

Bald Mountain gold-mining area, Northern Black Hills, South Dakota

Analytical data on specimens from radioactive occurrences in the Bald Mountain mining area indicate a progressive increase in rare-earth content toward the center of the gold-producing area and an increase in uranium content towards the fringe of the area. This zoning pattern may be helpful in finding additional uranium occurrences.

Colorado by R. U. King

Field work during the period consisted of reconnaissance investigations in the following four districts in Colorado: Ralston Creek, Jefferson County; Copperdale, Jefferson County; Lake George, Park County, and Shawnee, Park County.

Ralston Creek district

Three more radioactive deposits were investigated in the Ralston Creek district, Jefferson County. They lie between the known uranium deposits of the North Star and Schwartzwalder mines (Adams, TEM-154 and Circ. 320). The deposits are exposed thus far only in shallow pits. Torbernite and other

secondary uranium minerals are associated with primary and secondary copper sulfides in fractured zones in weathered quartz-biotite gneiss and hornblende schist. The deposits are near the northwest-trending breccia-reef structure known as the Rogers dike. Samples of the radioactive material contain from 0.01 to 0.64 percent U. Further investigation of these deposits will be included in the Ralston Buttes district studies.

Copperdale district

Near Copperdale, Jefferson County, about three miles northwest of the Ralston Creek area, secondary fluorescent uranium minerals were discovered in the adit of an abandoned mine once worked for copper and fluor-spar. The uranium deposit is associated with a northeast-trending fault that crosses a breccia-reef (Rogers dike). The reef at this locality consists of massive brecciated white quartz, with lenses of dark-purple fluorite and fragmented wall rocks with hematite and limonitic material. A pale-yellow uranium mineral (sahroeckingerite?) occurs as aggregates of tiny micaceous flakes along fractures and joints. A sample of the uranium-bearing material contains 0.11 percent U. The same reef, exposed in a road cut about a mile farther north, contains secondary copper minerals and is moderately radioactive. Further reconnaissance for uranium will be made in this area.

Lake George area, Park County

Quartz-feldspar-mica pegmatites in the Lake George area were found to contain scattered nodules of pitchblende, with orange and yellow alteration products. The pegmatite deposits are not of commercial interest.

Shawnee area, Jefferson County

The copper deposits in breccia-reef structures near Shawnee, Park County, were found to be barren of radioactive materials.

Wyoming
by J. D. Love

McComb area

The McComb area (fig. 40) lies between McComb ridge, a prominent boulder-covered ridge in the northern part of the Wind River Basin, and the south flank of the Owl Creek Mountains. A brief examination of uranium occurrences was made in April 1954 to obtain geologic data; the claims have previously been examined by geologists of the AEC.

Kermac No. 1 claim

This claim is in $SE\frac{1}{4}NE\frac{1}{4}NW\frac{1}{4}$, sec. 3, T. 39 N., R. 92 W. The uranium mineral is pale yellowish green, highly fluorescent, and was identified by L. B. Riley as metaautunite. The sample contained 0.59% eU and 0.80% U. The mineral is in the lower 10 to 20 feet of a 50-foot exposure of the upper Eocene (?) Tepee Trail (?) formation which was deposited in a valley cut in brown-pre-Cambrian granite. No extensive exploration had been done at the time of the examination. The metaautunite occurs abundantly in pale green bentonitic plastic claystone and green bentonitic coarse-grained arkosic sandstone. Maximum radioactivity noted on the surface was 3 mr/hr.

Fox claim

The Fox claim is in $SE\frac{1}{4}SE\frac{1}{4}NW\frac{1}{4}$, sec. 34, T. 40 N., R. 92 W., in reddish-brown coarse-grained granite directly adjacent to the overlap contact of the

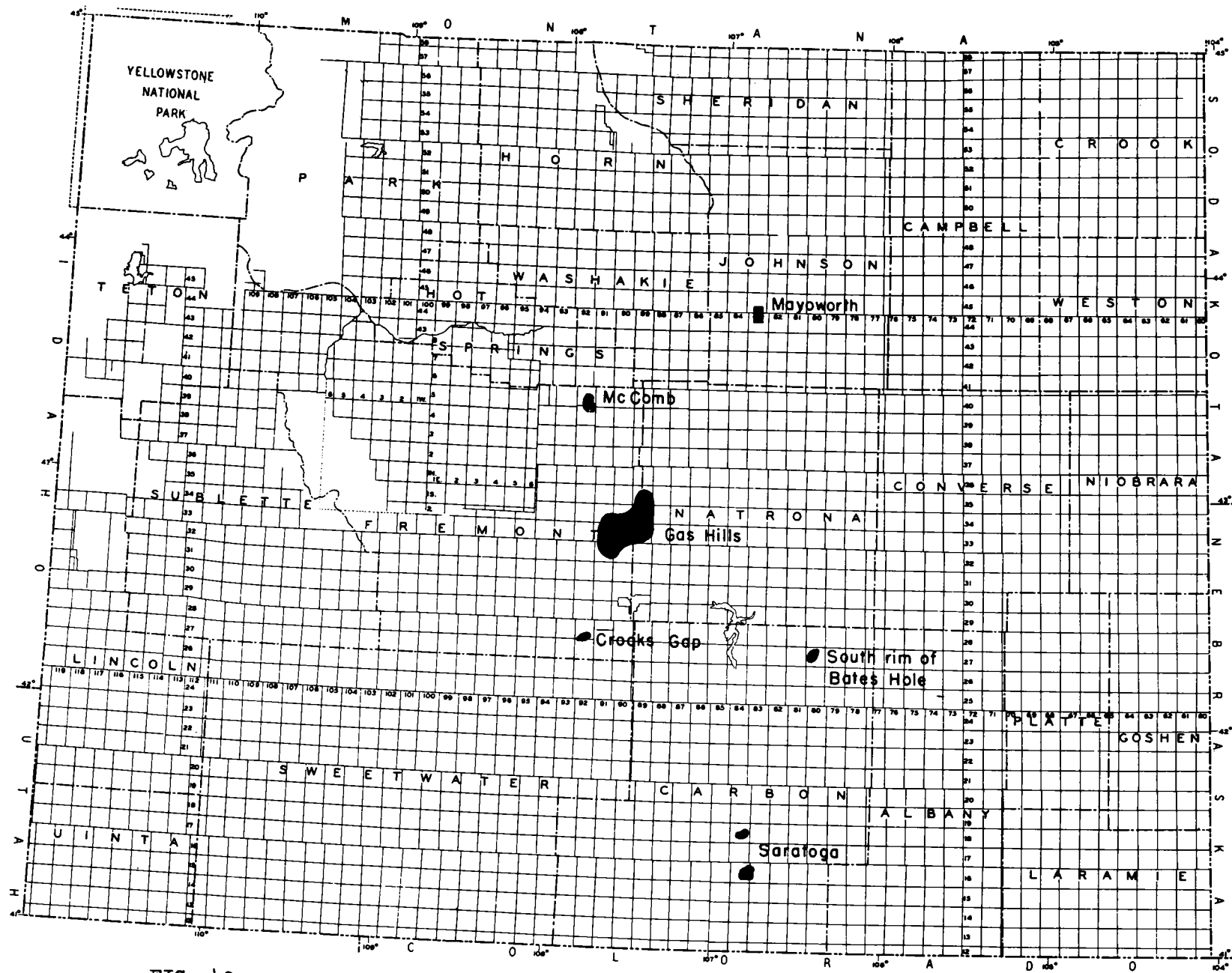

FIG. 40--MAP OF WYOMING SHOWING AREAS EXAMINED, DEC. 1, 1953 - MAY 31, 1954.

Tepee Trail (?) formation on the granite. The maximum radioactivity in the granite is less than 1 mr/hr. Some slight yellow fluorescence is visible but no uranium minerals were recognized. Exploration has been confined to two pits, each less than 4 feet deep, in fractured weathered granite. Fluorescence is common on fracture surfaces.

Hesitation claim no. 1

This claim is in NW $\frac{1}{4}$ SE $\frac{1}{4}$, sec. 27, T. 40 N., R. 92 W. A scintillation counter shows 0.5 to 1.5 mr/hr average count over a 15-foot circle around a 15-foot shaft 2 feet east of the old road from Shoshoni to the De Pass mine on Copper Mountain. The host rock is a boulder conglomerate with a bentonitic claystone matrix in the upper part of the Tepee Trail (?) formation. The boulders are chiefly of pink coarse-grained granite, black basic pre-Cambrian rocks, and Flathead quartzite of Cambrian age. A yellow non-fluorescent uranium mineral is present in the claystone and sandstone matrix between the boulders; in places this mineral coats the boulders, and in many instances impregnates granite boulders that appear to be fresh and impervious. The mineral has not been identified but looks like uranophane or metatyuyamunite. The mineral appears sporadically along the sides of the shaft from top to bottom.

Mac claim

This locality is in NW $\frac{1}{4}$ NW $\frac{1}{4}$ SE $\frac{1}{4}$, sec. 2, T. 39 N., R. 92 W. A uranium mineral similar to schroekingerite occurs in coarse-grained arkosic gray sandstone with a clayey matrix in the Tepee Trail (?) formation. The most radioactive spot is about 3 feet above the overlap contact of this formation on brown coarse-grained granite, about 50 feet west of a small reservoir.

The sandstone contains much black earthy material and sparse small pockets of a brilliant green fluorescent crystalline mineral that is probably schroekingerite. A scintillation counter shows a maximum of 3 mr/hr in the vicinity of the pockets of uranium mineral.

South rim of Bates Hole

Two small areas of radioactivity occur along the county road leading from the south rim of Bates Hole to Medicine Bow. The northern locality is approximately in sec. 9, T. 27 N., R. 80 W., Carbon County. The radioactivity is in an arkosic sandstone in the basal part of the White River or upper part of the Wind River formation. The area of radioactivity observed is about 100 feet in diameter; maximum radioactivity measured was 0.8 mr/hr. No uranium minerals were observed and the rocks are not fluorescent. A 3-inch grab sample of the arkosic sandstone taken 3 inches below the surface contained 0.072 percent eU, 0.006 percent U, and 0.49 percent V_2O_5 .

A second area of radioactivity is approximately in sec. 29, T. 27 N., R. 80 W., Carbon County, in an arkosic sandstone in the basal part of the White River or upper part of the Wind River formation, at a somewhat higher horizon than the locality in sec. 9, but in rocks with similar lithology. The area of radioactivity is on the north rim of a prominent ridge that runs east-west at right angles to the road. The maximum radioactivity begins about 50 feet east of the road and extends eastward for at least 180 feet. The maximum radioactivity observed was 0.9 mr/hr. No minerals and no fluorescence were observed. A 3-inch grab sample taken 50 feet east of the road contained 0.063 percent eU, 0.005 percent U, and 0.47 percent V_2O_5 . A

similar sample from the same zone 83 feet east of the road contained 0.037 percent eU, 0.003 percent U, and 0.33 percent V_2O_5 . A sample from the same zone 227 feet east of the road contained 0.024 percent eU, 0.002 percent U, and 0.16 percent V_2O_5 .

Saratoga area

South of Saratoga, on a high tableland area, mineralization is present in many prospect pits and on natural exposures of the North Park formation. The North Park formation consists of several hundred feet of non-marine tuffaceous light-colored rocks, chiefly sandstone with abundant glass shards. Uranium minerals were seen in sections 7, 18, and 19, T. 16 N., R. 83 W., and sections 13, 14, and 15, T. 16 N., R. 84 W. Uranium minerals likewise occur in alluvial gravel and clay that overlie the bedrock. Yellow coating on the under sides of pebbles in the alluvium is very common and the minerals are typically associated with caliche-like deposits of calcium carbonate and gypsum.

North of Saratoga, approximately in sections 15 and 22, T. 18 N., R. 84 W., a yellow uranium mineral reported to be carnotite occurs in the Browns Park formation. At this locality, more than 300 feet of the formation is exposed. It consists of light brown to gray fine-grained tuffaceous sandstone, interbedded with thin but persistent white limestone containing abundant black chalcedony. Uranium minerals coat fractures in the thick sandstone forming a prominent cliff on the north side of the North Platte River, in carbonaceous shale about 50 feet above the cliff-forming sandstone, and in a white chalcedonic limestone. In every observed occurrence, the mineral does not appear to have penetrated the rock except along fractures.

Crooks Gap

Yellow uranium minerals occur in sec. 32, T. 28 N., R. 92 W., in arkosic conglomeratic sandstone in the lower Eocene rocks on the east side of Crooks Gap. The locality has been examined by geologists of the AEC. Minerals were observed in places through a section of about 75 feet of rocks, but are concentrated adjacent to carbonaceous shale partings, carbonized wood fragments, and in highly ferruginous zones. The mineral was identified as phosphuranylite ($\text{Ca}_3(\text{UO}_2)_5(\text{PO}_4)_4(\text{OH})_4 \cdot 2\text{H}_2\text{O}?$), and a selected sample contains 0.17 eU. The uranium-bearing zone is about 200 feet above the base of a sequence of brown and gray coarse clastic rocks, chiefly arkosic sandstones containing lenses of giant granite boulders, variegated claystones, and carbonaceous shale, the total thickness of which is more than 1,000 feet. A sample of water from a spring, likewise in sec. 32, T. 28 N., R. 92 W., contained 250 ppb of U. The uranium appears to have been deposited in many places where there are concentrations of carbonized wood fragments, carbonaceous shale partings, or very ferruginous sandstones.

Southwest district
by R. B. Ramp

No significant radioactivity was detected in the Victorio district, Luna Co., N. Mex., and the Organ district, Dona Ana Co., N. Mex. Radioactive materials were studied in 3 other districts in Arizona and New Mexico:

Pearce district, Cochise Co., Arizona

Anomalous radioactivity was detected at Fluorine Hill, $2\frac{1}{2}$ miles east of Pearce, in secs. 33 and 34, T. 17 S., R. 25 E. The hill is composed

mainly of partly silicified rhyolite porphyry; narrow discontinuous fractures cut the rhyolite and are stained by iron minerals. Small prospect pits have been dug where the fractures are filled with calcite and hematite.

The rhyolite porphyry is slightly radioactive throughout, a representative sample of the rock containing 0.008 percent eU. The only increase in radioactivity was detected at a prospect pit on the south side of the hill near the crest where a narrow carbonate vein that contains a small amount of dark-purple fluorite and flecks of uranophane or autunite is exposed. A grab sample of vein material contains 0.11 percent U.

Black Rock district, Yavapai Co., Ariz.

The Abe Lincoln mine in the Black Rock district is in the SW $\frac{1}{4}$ sec. 11, T. 8 N., R. 3 W., (unsurveyed) and is 14 miles by road northwest of Wickenburg, Arizona. The Abe Lincoln vein system occupies a northeast-trending fault zone in a pre-Cambrian (?) gneiss-schist complex intruded by granite and dikes of felsite, trachite porphyry, and basalt. Chalcopyrite is the chief ore mineral with subordinate azurite, chalcocite, and malachite. The gangue minerals are principally pyrite, quartz, calcite, purple fluorite, and limonite. Some specimens of vein material on the dumps contain a secondary yellow uranium mineral which, in one specimen, was identified by X-ray methods as schoepite ($4\text{UO}_3 \cdot 9\text{H}_2\text{O}$?); pitchblende may be present. Samples from the dumps ranged from 0.074 percent to 0.46 percent U. Samples of radioactive material in place could not be obtained inasmuch as most of the mine workings are caved and flooded.

Radioactive material was found also on the Bracken property 1 mile west of the Abe Lincoln mine. Samples from the northwest-trending quartz vein on

the property contain 0.006 and 0.012 percent U. No uranium minerals were observed. Also on the Bracken property a 20-foot zone of radioactive altered migmatite is exposed in a road-cut. A 1.6-foot channel sample across the most radioactive part of this zone contains 0.012 percent U.

Another area, approximately 13 miles by road northeast of Wickenburg, contains weakly radioactive material in granite gneiss exposed in a road-cut 0.8 mile northeast of the Monte Cristo mine. Although other slight increases in radioactivity were detected within a mile of the roadcut, no significant concentration of uranium-bearing material could be found.

Tyrone district, Grant Co., N. Mex.

A reconnaissance for uranium is currently being conducted in areas adjacent to the central part of the Tyrone district. Uranium is present in the White Signal district southeast of Tyrone, in the Tyrone district, and in the Black Hawk district northwest of Tyrone. The purpose of the present work is to determine whether uranium occurs in the apparently favorable areas between the three districts.

Interest in the occurrence of uranium in the Dripping Spring formation in Gila Co., Ariz., has greatly increased. As an indication of the interest, it is reported that approximately 1000 claims were located in a single 2-month period this spring.

Nevada-Utah district by A. O. Taylor

Most of the report period was spent on map compilation, preparation of reports, and laboratory study of rock and ore samples. Reconnaissance

geologic maps and reports on the Newton Mining district and on the Wah Wah mountains area, Beaver Co., Utah, are nearly complete. Prospector interest in the two areas has increased despite the fact that no commercial uranium deposits have yet been found.

Mystery-Sniffer mine, Beaver Co., Utah

At the Mystery-Sniffer mine, a zone 1/2 to 2 feet wide has been found to contain autunite. Samples from the zone assay from 0.15 to 0.32 percent U.

Staats fluorite mine, Beaver Co., Utah

Samples from the new fluorite ore body (TEI-390, p. 215) contain 0.004 to 0.093 percent U and average about 0.01 percent U. No specific uranium minerals were observed in higher grade samples. The fluorite ore and gangue are relatively fresh and unoxidized. There is no apparent reason to expect increasing uranium content with greater depth. However, the mine owner now plans an exploratory winze in the autunite-fluorite mineralized zone in the south end of the mine to test the grade and character of the uranium minerals at greater depth.

Gold Butte mining district, Clark Co., Nev.

Inactive mines and prospects in the Gold Butte mining district were examined for radioactive materials in February with negative results.

Sheeprock and Simpson Mountains, Juab and Tooele Cos., Utah

Five radioactivity anomalies in the Sheeprock and Simpson mountains were detected by airborne methods. Two of the anomalies were over known deposits

of radioactive materials. The remaining three anomalies will be field checked in the near future.

Northwest district
by F. C. Armstrong

A report on the placer deposits on Red River near Elk City, Idaho Co., Idaho, is almost complete. It does not appear that radioactive black minerals are economically recoverable from these deposits even as a by-product of the gold-dredging operations.

Two radioactive occurrences on the 2800-foot level of the Galena mine, Shoshone Co., Idaho, were examined. One of these is sufficiently good to warrant more exploration.

California district
by H. G. Stephens

Work completed during the reporting period includes (1) reconnaissance examination of 29 mine properties, claims and prospects in Kern, Inyo, Plumas, Tuolumne, Calaveras, Monterey, and San Benito Counties and car-mounted geiger counter road traverses totalling 600 miles. Of the properties examined, only the Middle Butte mine and a uranium prospect on the Uranium Mines, Inc. lease, both in the vicinity of Mojave, Kern Co., showed anomalous radioactivity; (2) evaluation of data on four additional properties; and (3) completion of radioactivity tests of 8,000 rocks and mineral specimens in collections of the California Division of Mines and the University of California.

Reconnaissance in the Gavilan Mesa area, Monterey Co., and in the vicinity of the Pinnacles National Monument, Monterey and San Benito Cos.,

consisted of examination of 15 mine properties and prospects for anomalous radioactivity; checking bedrock exposures of granite, rhyolite, andesite, and sandstone; and traversing approximately 350 miles of roads in these two areas with car-mounted geiger counter. No anomalous radioactivity was detected.

Eight mine properties in the Mother Lode gold belt, Calaveras and Tuolumne Cos., were examined after strong radioactivity values (as high as 3.0 mr/hr) were detected in gold specimens from the Mother Lode in the collections of the California Division of Mines and the University of California. None of these mines, nor their dumps, showed anomalous radioactivity, which might be explained by inaccessibility of underground workings from which the radioactive specimens may have been collected, or removal of high-grade gold ore with which the radioactive minerals may have been associated. About 100 miles of roads in the area were traversed without detecting any significant radioactivity.

The Middle Butte mine, sec. 16, T. 10 N., R. 13 W., SBBM, Kern Co., showed significant radioactivity. Autunite coating fractures in kaolinized rhyolite were observed in the underground workings. Radon gas was suspected because high radioactivity measurements were commonly detected near the floor of certain drifts and crosscuts where ventilation was poor. Some of the rock samples collected from spots where radioactivity values were as high as 1.5 mr/hr showed no anomalous radioactivity when taken to the surface; radon gas is believed responsible for the high readings in such instances.

High radioactivity measurements were made at the Uranium Mines, Inc., prospect a mile south of the Rosamond uranium prospect (TEM-514). The maximum intensity was observed at an outcrop of coarse-grained granite and

aplite separated from tuffaceous sandstone of the Rosamond formation (Miocene) on the north by an east-trending fault contact. Fractures in the granite sparsely coated with autunite strike N. 40° W. and dip steeply NE.

Radioactivity tests of 8,000 rock and mineral specimens in collections of the California Division of Mines and the University of California were completed during this period. Of the 182 radioactive specimens, 18 were from California localities. Reconnaissance examinations in the Mother Lode gold belt include the mine properties that were represented by 5 significantly radioactive gold ore specimens in the California museum collections.

RECONNAISSANCE FOR URANIUM IN ALASKA
by J.J. Matzko

Mineralogic studies were made on samples submitted by prospectors and on samples collected during and prior to the 1953 field season.

Chemical determinations of phosphorites and kerogenaceous black shales in the Brooks Range, northern Alaska, indicate a maximum of 34 percent P_2O_5 and as much as 0.02 percent uranium. An age determination by the Larsen method on a zircon concentrate from the granitic intrusive at Mount Fairplay, Tanacross quadrangle, east-central Alaska, gave a Cretaceous age of about 99 million years. A sample of float rock from the southern part of Alaska, submitted in 1953 by a prospector, was identified as a friable sandstone with feldspar fragments. Metatyuyamunite and metaautunite coat the iron stained quartz fragments; and these secondary uraniferous minerals are also found on the cleavage planes of the iron stained potash feldspar.

For the next 6 months, field studies (fig. 41) will include: (1) examination of the radioactive Yakataga beach and terrace deposits (Moxham, Circ. 184) to determine whether or not the placers may be an economic source of radioactive minerals, and to learn the bedrock source of the radioactive minerals; (2) search for the bedrock source of the metatyuyamunite and metaautunite found in float material collected in 1953; (3) detailed water sampling in Circle Hot Springs and Hyder areas; (4) airborne scintillation counter traverses over selected areas; and (5) carborne scintillation counter traverses over as many roads as possible.

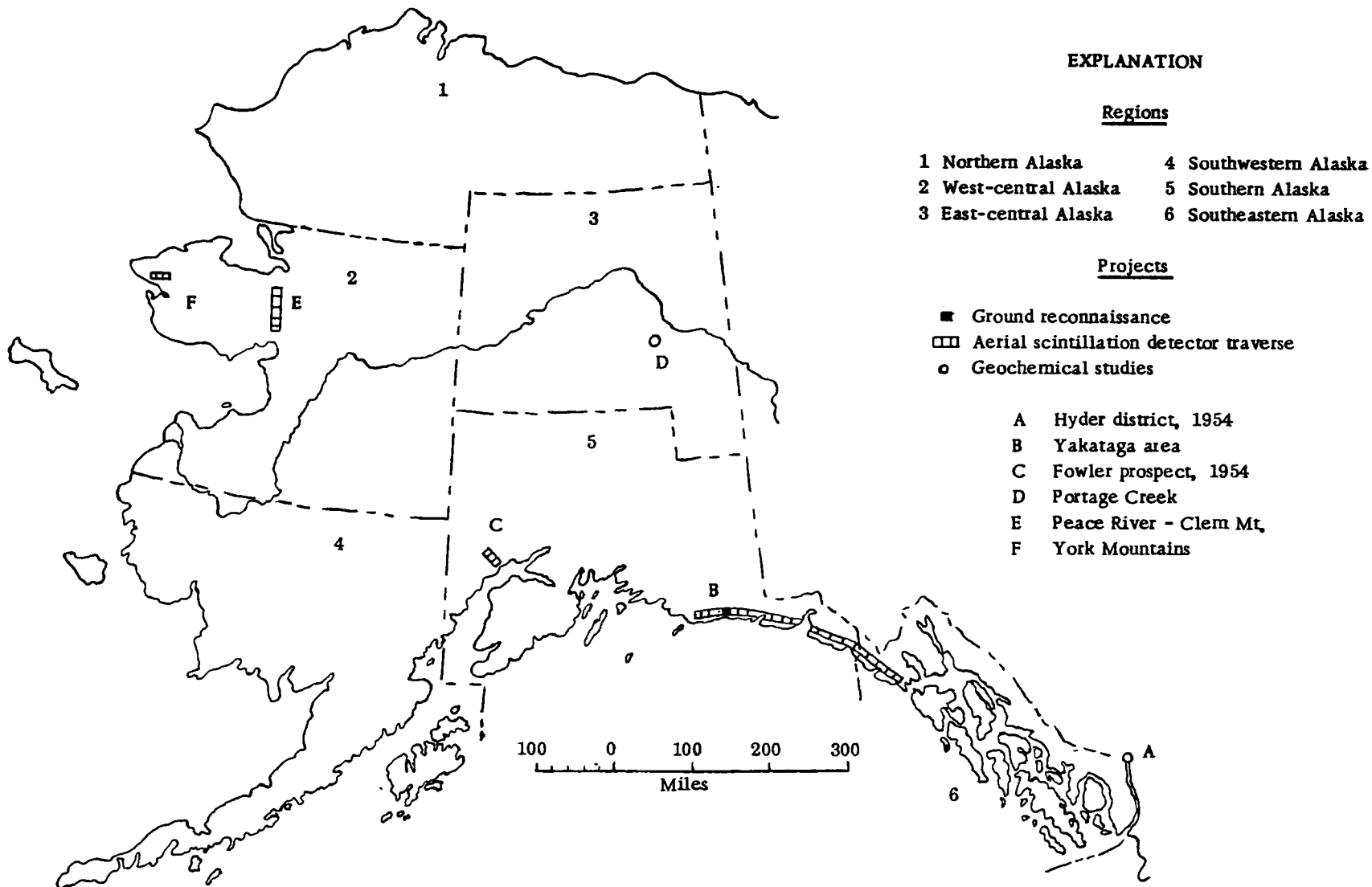

FIG. 41--LOCALITIES IN ALASKA TO BE EXAMINED FOR URANIUM DEPOSITS IN 1954.

ANALYTICAL SERVICE AND RESEARCH ON METHODS

Sample control and processing, Washington and Denver
by J. J. Rowe

The operation of the Sample Control office was improved to provide more efficient surveillance of the progress of analytical requests through the laboratory. A uniform system for sample control has been established in both Denver and Washington.

The backlog of analytical work was reduced substantially according to plans of the preceding six months. This resulted from improved efficiency in the laboratory and from reduction in the number of samples submitted. The backlog represents about three months of chemical work and one-and-a-half months of spectrographic work. The laboratory analytical functions are stabilizing with the prospect that the number of samples on hand will be maintained at the present level.

Analytical services for the AEC program were provided during the last six months as shown in table 26.

Radioactivity

Equipment and methods, Washington
by F. J. Flanagan

In cooperation with the Mineralogical Techniques Research Project, two experimental designs were set up to test the efficiency of the Cone Splitter (TEI-371) as compared to other methods of sample splitting. A study is being made of a corollary problem, the splitting of granite samples for analysis, to determine the optimum sample size necessary for the analysis of uranium in the range 0.00000X%.

Table 26.--Summary of analytical services and sample inventory, December 1, 1953 - May 31, 1954

Project or source	Determinations			Samples			
	Chemical		Spectro- graphic	Radio- activity	On hand Dec. 1	Received Dec.-May	On hand May 31
	U	Others					
<u>Washington Laboratory</u>							
Southeast Phosphates	2,158	876	9,180	7,389	7,535	5,713	5,497
A.E.C.	278	53	8,975	58	22	295	7
Fuels Branch	2,437	1,082	18,496	3,606	3,353	811	156
N. W. Phosphates	215	467	2,312	274	124	522	219
Alaskan Samples	17	14	1,088	116	91	43	2
S. E. Monazites	-	-	1,224	-	71	-	-
Uranium in Water	229	45	2,720	-	143	112	24
G&P Mineralogy Projects	211	136	5,988	-	82	104	15
Geochemistry of Uranium	673	172	9,952	287	795	265	434
Miscellaneous **	560	326	12,386	581	394*	755	412 *
Total	6,778	3,171	72,321	12,311	12,610	8,620	6,766
<u>Denver Laboratory</u>							
Colorado Plateau Deposits	752	1,409	38,928	1,272	1,027	869	369
Plants and Soils	1,151	526	120	121	1,645	269	330
Oil Well Drillings	-	-	1,008	-	102	-	72
S. E. Phosphates	-	-	-	151	626	-	475
A.E.C.	1,335	995	3,061	2,076	563	2,438	809
Reconnaissance	1,419	1,659	53,448	1,320	3,143	2,272	1,882
Fuels Branch	1,068	886	10,690	1,491	1,139	806	274
Miscellaneous **	223	479	1,695	220	383	989	731
Total	5,948	5,954	108,950	6,651	8,627	7,643	4,942
GRAND TOTAL	12,726	9,125	181,271	18,962	21,237	16,263	11,708

* Includes 240 Sea Waters and Bottoms samples.

** Includes public samples.

In relation to color reflection measurements previously reported (TEI-390, p.163) efforts are being directed toward the design of an automatic system to record the entire spectrum of the reflection of light of different wave lengths from the surfaces of solid samples. A preliminary study will then be made to estimate the relationship, if any, between different ions and the color of radioactive materials.

Analysis and research, Washington
by F. E. Sentele

Thorium analysis

After the theoretical calculation for the photographic alpha-star method of thorium analysis was completed, further work was held to a minimum due to a decrease of interest in this method. Recently, when it became evident that a good method of thorium analysis would be of great help in the alpha-lead method of age calculation, work was again started on the modified emanation method. The furnace used in this method was altered to reduce sample alloying and the formation of unwanted oxides. Preliminary runs indicate that the counting efficiency is independent of grain size for all practical purposes. It appears that the method is feasible and it is expected that thorium analyses will be made in the immediate future.

Metamictization of zircons

The X-ray analysis of the Oak Ridge National Laboratory alpha-irradiated zircon was completed and a small but definite change was observed.

A second sample of zircon was irradiated with 10^{15} deuterons in the Naval Research Laboratory's Cockcroft-Walton accelerator. No significant change was determined by X-ray analysis.

Aliquots of a metamict specimen of zircon were exposed to equal dosages of alpha particles but at different rates. The alphas were 400 kw particles from the Cockcroft-Walton accelerator at the Oak Ridge National Laboratory. By X-ray analysis, the maximum current which could be used to produce radiation damage without causing significant annealing was determined. The tests showed that a current of $25\mu\text{A}$ could be used. A fresh zircon was then bombarded at this rate for a total dosage of 7.65×10^{18} alphas. Subsequent X-ray analysis showed a small increase in the lattice parameter.

Activation Analysis

Four samples of copper from a copper-silver "half-breed" were prepared for mass-spectrographic analysis and subsequent activation analysis at Oak Ridge National Laboratory. Preliminary analyses by an activation technique show 64.88% and 68.94% Cu^{63} in two of the samples. No mass spectrographic check analysis has yet been made.

Analysis and research, Denver
by J. R. Rosholt

Radiochemical research on the natural radioactive series is continuing. The development of methods for analysis of Ra^{226} , Pa^{231} , and low-level Th^{232} by alpha particle scintillation detection was completed. The determination of the equivalent counting rate of these nuclides along with that of Rn^{222} and Pb^{210} under the conditions of measurement and independent of comparative calibration with standard ore samples is in the final stage of development. Radiochemical methods of analysis are now available so that all of the major sources of natural radioactivity can be determined quantitatively. The

following radiochemical analyses were made:

Th ²³²	31
Th ²³⁰	22
Ra ²²⁶	35
Ru ²²²	26
Pb ²¹⁰	<u>28</u>
Total	142

To supplement the existing radon trains, a special train for the determination of low-level Ra²²⁶ content was set up and put into operation. Calibration and standardization is nearly completed and samples are being analyzed.

The very sensitive alpha scintillation counter has been and is presently undergoing further development. The optimum geometry, sample size and form of reflecting surfaces were tested. The largest size counter designed will accommodate a sample having a surface 22 inches in diameter. The optimum distance between the phosphor screen and the photomultiplier tube is 11½ inches. Counters designed to accommodate a 12-inch and a 15-inch sample were also fabricated. Further investigation, involving the comparison of parabolic focusing reflecting surfaces to the present conical reflecting surfaces is under way. It is expected that the detection efficiency will be increased.

Spectrography

Spectrographic methods, Washington

Emission spectroscopy, by C. L. Waring

Improvement in technique, chemical result comparisons and constant study of the semiquantitative method have produced evidence that the factor of 10 brackets can be halved for most types of materials.

The determination of the optimum exposure conditions using a new grating in the JACO spectrograph was completed and thirteen elements were standardized.

The development of a rapid spectrographic method for the determination of hafnium and the hafnium-zirconium ratio in zircon was completed. A number of zirconium-hafnium ratios of zircon separated from pegmatite rocks, granites, granodiorites and diorites will be analyzed to fill in the gap of missing knowledge.

Infrared spectroscopy, by Robert G. Milkey

The past six months was spent primarily in setting up the infrared laboratory and commencing sample analysis. The spectrometer was adjusted and calibrated and a file of absorption spectra was assembled. Investigations were made to determine the optimum methods of preparation of the various types of samples to be examined.

The spectra of a variety of organic substances found in uranium-containing carbonaceous rocks were determined and the functional groups probably present were identified. Positive identification of the groups present will be made by determining the spectra in a region of greater resolution.

The spectra of a number of inorganic minerals of uranium were also obtained and the presence of hydroxyl groups as well as silicate structure in the cases of "coffinite" and thorogummite and the absence of the hydroxyl groups in the case of zircon were established.

The spectra of a number of uranium salts were determined for future reference.

Spectrographic methods, Denver
by A. T. Myers

During the past six-months, a total of 108,950 determinations were made on 2,017 samples submitted for analysis. For this period there was

an increase of 319 samples analyzed and an increase of 17,911 determinations made over the previous six-month period.

The information in TEI-179 was published in the American Journal of Science, vol. 251, p. 814-830, November 1953. This consists of quantitative data showing the degree of contamination of rock samples when ground to 80-mesh with steel plates mounted in a Braum type grinder.

A new sensitivity chart (table 27) for the Denver laboratory was prepared and issued May 1954.

Table 27.--Standard sensitivities for the elements determined by the semi-quantitative method Denver--May 1954

%	%	%
Ag - 0.0001	Hf - 0.1	Re - 0.005
Al - 0.001	Hg - 1.0	Rh - 0.005
As - 0.1	In - 0.001	Ru - 0.005
Au - 0.005	Ir - 0.005	Sb - 0.05
B - 0.005	K - 1.0 (0.005)*	Sc - 0.001
Ba - 0.0001	La - 0.005	Si - 0.001
Be - 0.0001	Li - 0.001 (0.0001)*	Sm - 0.01
Bi - 0.001	Mg - 0.005	Sn - 0.001
Ca - 0.001	Mo - 0.001	Sr - 0.0001
Cd - 0.005	Mn - 0.0005	Ta - 0.05
Ce - 0.05	Na - 0.05 (0.001)*	Te - 0.5
Co - 0.0005	Nb - 0.001	Th - 0.05
Cr - 0.0005	Nd - 0.01	Ti - 0.001
Cu - 0.0001	Ni - 0.0005	Tl - 0.05
Dy - 0.05	Os - 0.005	U - 0.05
Er - 0.005	P - 0.5	V - 0.001
Fe - 0.001	Pb - 0.001	W - 0.01
Ga - 0.001	Pd - 0.0005	Y - 0.001
Gd - 0.05	Pt - 0.005	Yb - 0.0005
Ge - 0.0005	Rb - - (0.01)*	Zn - 0.05
		Zr - 0.001

* A second exposure is required for the higher sensitivity listed, using a 20 mgm. sample charge.

Chemistry

Analysis of raw materials, Washington
by Irving May

The major effort during the past six months was devoted to the reduction of the large backlog of samples. Of those now in the laboratory, the largest groups consist of ocean bottom samples being analyzed for uranium and P_2O_5 and Florida phosphate samples for uranium.

A preliminary statistical report on the study of the precision of the uranium determination in shales recently was received from Dr. Youden of the Bureau of Standards.

Patent No. 2,663,801 was issued on December 22, 1953, to Morris Slavin, Mary Fletcher, and Irving May. The patent, which is assigned to the AEC, covers a transmission fluorimeter developed in this laboratory for use in the fluorimetric determination of uranium. Modifications of this instrument are in regular use by USGS and other laboratories.

Five chemists from foreign and American laboratories visited the laboratory to receive training in the determination of uranium and thorium. These visits ranged from periods of several days to several months.

Cooperative studies were continued for the purpose of checking the accuracy of analytical methods and for the development of new techniques. A number of samples were received for uranium determinations for cross-check purposes. A suite of samples was analyzed for zirconium plus hafnium. A group of analyzed samples were selected for use in the development of an X-ray fluorescence method for thorium; check determinations of thorium are being performed as required. Check work is also underway on the determination of traces of zinc in rocks and on the determination of fluorine in silicate rocks.

Analysis of raw materials, Denver
by L. F. Rader, Jr., and Wayne Mountjoy

A total of 11,902 determinations were made on 10,966 samples. Uranium, vanadium, calcium carbonate, and recently copper, constitute the chief metals analyzed for on a routine basis. Quick analytical service on drill cores from USGS Colorado Plateau drilling operations and similar samples from the Denver AEC office constitute the most important part of the analytical work.

A study of mixed carbonate - fluoride fluxes of various ratios has been made jointly by the X-ray and chemistry units in an effort to determine the most sensitive mixture to uranium fluorescence and the least sensitive mixture to such influences as heating, cooling, and crystal strain. The data are now under investigation by statistical methods. Fluorescence measured by fluorophotometers seems to confirm conclusions drawn from the X-ray study.

Controlled ashing of plant material, coal, and other carbonaceous materials to determine possible uranium loss has been undertaken in a tube furnace. Condensable volatile combustion products have been recovered and analyzed, in addition to the scrubber solution used to wash all non-condensable gasses from combustion. Results at this time are inconclusive, and the study is to be continued.

Standard samples for cross-checking purposes have been prepared for analyses as large samples of various types have been obtained. Each sample has been ground to pass a 100-mesh screen, mixed for several days in a revolving drum, and about 70 separate splits prepared. A total of eleven different samples of various grades are ready to be sent out to other

laboratories for analyses, as soon as test work on the uniformity of the splits of each sample can be completed.

Several hundred fluorine determinations on materials very low in fluorine but containing large amounts of silica (e.g. obsidian), necessitated a study of methods for this purpose. A modified method based on a combination of several published methods has been evolved and checked.

Automatic-recording, titrating equipment has been set up and calibrated to titrate calcium and magnesium in solution with a standard Versene solution in the presence of a suitable dye as an indicator. The reproducibility and range of concentration covered by this method are at least as good as with the flame photometer, and with some materials the method is more rapid.

Research on analytical methods

The sampling problem in the determination of small percentages of uranium in igneous rocks, by Alexander Sherwood and F. S. Grimaldi

In spite of fine grinding and careful splitting of igneous rock samples, there is still evidence of lack of homogeneity in samples taken for analyses.

This problem is especially troublesome in samples of granite, which contain 0.01 to 5 ppm U. Most of the uranium present is contained in the accessory minerals which constitute a very small fraction of the rock. The results of analysis for uranium on such samples may thus be largely determined by the size and homogeneity of the sample taken for analysis.

Work on this project indicates the desirability of using a one-gram sample of rocks to minimize this sampling error. Calculations show that no serious error will result from this cause if one-gram samples are used

on rocks containing 1 ppm or more of U. This calculation is based on the assumption that the rocks contain 0.01 percent zircon and the zircon contains 0.1 percent U. Statistical calculations are required to determine what size sample must be taken to give results within certain confidence limits on rocks containing less than 1 ppm U.

The determination of uranium by the spectrophotometric method,

by H. I. Feinstein

As thiocyanate appeared to be the most promising reagent for the spectrophotometric determination of uranium, an effort was made some time ago in this laboratory to apply recommended methods using this reagent, but was abandoned when the method was found to be generally unreliable.

Recent reports on the thiocyanate reaction indicate that it is possible to stabilize the color system by working from acetone medium and for this reason reinvestigation of the thiocyanate system was initiated. Preliminary work indicates that even the new procedures have several undesirable features. The variables such as acidity, thiocyanate concentration, and stannous chloride concentration have to be more rigorously defined. The acidity and thiocyanate factors interact and both variables have to be studied simultaneously to arrive at optimum conditions.

Because of the need for a reliable spectrophotometric method, it is hoped that even if the thiocyanate method cannot be made ideal, it can be used temporarily while a better method is being developed.

Automatic titration of calcium and magnesium, by C. A. Kinser

An experimental instrument was built for the automatic titration of calcium and magnesium on the same operating principles as that devised and used by Brannock and Shapiro in their rapid rock analysis methods.

In setting up this instrument several modifications were made in an effort to increase sensitivity range, accuracy, and convenience. Preliminary work gave good reproducibility of results and the instrument is now being used as an analytical tool. Some changes, however, are contemplated which will make the measurement of titrating solution more direct and eliminate the problem of changing hydrostatic pressure in the titrant as the titration proceeds.

The determination of aluminum by the ferron method in aluminum phosphate zone samples from the Florida phosphate deposits, by Maryse Delevaux and F. S. Grimaldi

Experimental work was completed and the method is now in routine use. The procedure determines aluminum with an accuracy well within ± 3 percent of the aluminum content of the sample. It is of general applicability although primarily developed for the aluminum phosphate samples of the Florida phosphate deposits containing 0 to 40 percent P_2O_5 and 0 to 35 percent Al_2O_3 .

The determination of sodium and potassium by flame photometric methods on shale, siliceous, argillaceous and phosphatic materials, by Irving May and Lillie B. Jenkins

Work on this project was completed and the methods are of general applicability and are now in routine use in the laboratory. Analytical results obtained with these methods compare favorably with the classical J. L. Smith method which is very time-consuming.

Research associated with the analysis of two mineral samples, by

F. S. Grimaldi and Harry Levine

Methods were devised, tested and used for the complete analyses of a fergusonite and a new mineral (a potassium uranyl arsenate containing phosphorus).

Note on the analysis of phosphate rock

As a result of the research work that has been done on rapid methods for the analysis of phosphate rocks, this laboratory is now prepared to do the following determinations on this type of material on a routine basis: Na, K, Al, Fe, Ti, Ca, P, and S.

GEOCHEMICAL AND PETROLOGICAL RESEARCH ON BASIC PRINCIPLES

Distribution of uranium in igneous complexes
by David Gottfried for E. S. Larsen, Jr.

During this report period investigations were directed toward (1) determination of the distribution of uranium in the minerals of igneous rocks; (2) the problem of sampling and obtaining a representative sample of rock for uranium analysis; (3) development of techniques and methods for the rapid determination of uranium and thorium in geologic materials; and (4) additional work on the distribution of uranium in rocks.

Table 28.--Uranium content of minerals of the Southern California Batholith

Mineral	No. of samples	No. of analyses	Range U content (ppm)	Average U Content (ppm)
Olivine	1	1		<0.01
Ilmenite	1	1		.1
Plagioclase	20	27	0.07-6.0	1.6
Orthoclase	15	20	0.16-8.2	1.9
Quartz	18	22	0.20-6.0	2.2
Fluorite	1	3	3.0 -4.0	3.5
Diopside	1	1		3.7
Hypersthene	5	6	<0.01-14.0	4.7
Biotite	19	44	0.3 -29.0	5.7
Magnetite	13	20	0.68-24.0	7.1
Augite	6	8	0.8 -39.0	7.7
Muscovite	1	2	7.9 - 8.1	8.0
Hornblende	18	27	0.1 -85.0	18.0
Garnet	2	3	5.5 - 7.5	6.0
Epidote	3	4	15.0 -50.0	32.0
Apatite	8	9	31.0 -130.0	67.0
Allanite	3	6	51.0--360.0	180.0
Sphene	4	7	27.0 -350.0	196.0
Monazite	1	1		820.0
Zircon	14	17	90 - 4,600	1367.0
Xenotime	2	2	360.0 -12,700	6630.0

Table 28 shows that uranium is greatly concentrated in the minor accessory minerals of igneous rocks. The large variation of uranium content in the ferro-magnesian minerals is due in part to the presence of inclusions of zircon. Spectrographic determinations of these minerals show a correlation of uranium with zirconium.

Southern California batholith

To test the uniformity of uranium content of a fairly uniform rock unit, fourteen samples of Woodson granodiorite from a single stock were analyzed. The uranium content ranged from 1.0 to 2.8 ppm. The results do not indicate an concentration of uranium in rocks collected from the border phases of this stock.

San Bernardino County, California

An airborne radioactivity survey over the Rock Corral area gave high anomalies related to a quartz monzonite porphyry and to biotite-rich inclusions or small roof pendants. The uranium analyses of these rocks are shown below:

Table 29.--Uranium analyses of rocks from Rock Corral area, California

Rock type	No. of samples	Range U content (ppm)	Average U content (ppm)
Quartz monzonite porphyry	7	4.0- 9.3	8
Biotite-rich inclusions	2	35.0-60.0	47

The heavy mineral concentrates of the biotite-rich inclusions contain abundant zircon with exceptionally high alpha activity.

Adams Tunnel, Colorado

Seventy-nine samples of rock were analyzed from a section through the Adams Tunnel. The material was supplied by Dr. Francis Birch, Harvard University.

Table 30.--Analyses of rocks from Adams Tunnel, Colorado

Rock type	No. of samples	Range U Content (ppm)	Average U Content (ppm)
Granite	42	3.0-35.0	5.2
Quartz diorite gneiss	9	1.6- 6.8	3.8
Injection schist	18	0.1- 8.4	2.4
Injection gneiss	8	0.2- 4.0	1.6
Pegmatite	1		4.0
Dolerite dike	1		0.4

New England

Preliminary investigations on three magma series from New Hampshire were made. The rocks were measured for equivalent uranium content and several rocks were separated into monomineralic separates.

Table 31.--Analyses of New England magmas

Rock series	No. of rocks	Range eU (ppm)
New Hampshire magma series	65	20 - 60
Oliverian magma series	67	10 - 60
Highlandcroft magma series	10	10 - 30

Table 32.--Age determinations (New England)

Rock series	Age from geology	No. of Rocks	Range (MY)	Average age by Pb/ α (MY)
New Hampshire	Devonian	5	253 - 333	310
Oliverian	Devonian	4	273 - 328	312
Highlandcroft	Ordovician	2	351 - 424	387

The mineral separations from rocks of all three magma series show that radioactivity is concentrated in zircon, monazite, allanite, xenotime and sphene. Zircons from aplites and pegmatites have unusually high alpha counts (greater than 6000 α 's/mg/hr.). Uraninite occurs locally associated with this high activity zircon.

Boulder Batholith, Montana

Chemical and petrographic and field studies of the batholith were continued. Mineral separations were completed on several rocks of the batholith. Uranium determinations were not completed on the rocks and minerals. Age determination on the rocks are in very close agreement with the assigned geologic age of approximately sixty million years.

Research on methods and techniques

Owing to the difficulty of obtaining reproducible results on the uranium content of rocks that contain less than 1 ppm U, a series of tests were made to determine the factors to which large variations may be attributed. It is believed the amount of sample used at present (100 to 200 mg) is insufficient to be a representative split of the gabbros and intermediate rocks. Inasmuch as a significant amount of the uranium is present in the accessory minerals the lack of homogeneity in the split analyzed is a major factor.

Investigations are in progress on the uses of gamma-ray spectrometry in geology. The thorium-to-uranium ratios should be determinable by taking ratios of the different gamma peaks in the gamma-ray spectra of the two series. Preliminary results are encouraging and may be applicable to rocks as well as radioactive accessory minerals.

Weathering, transportation, and redeposition of uranium
by R. M. Garrels

The individual specimens from the four channel samples collected from mines in the vicinity of Paradox Valley, Uravan district, have been sawed in two. Detailed work was done only on a channel from the Mineral Joe mine of the Jo Dandy group. Thin and polished sections were obtained and examined. A considerable variety of mineral species are present, but all are interpretable on the basis of oxidation of a primary low valence mineral association. X-ray and petrographic work is being continued to identify the various species. The remaining half of the sawn specimens was hand ground to -40 mesh and splits obtained for chemical and spectrographic analysis as well as for the determination of gross oxidation states.

The Eh-pH apparatus is entirely completed and ready for full-scale operation. A procedure for running sets of samples was worked out and was checked and amplified by the Bureau of Standards. A radiometric log across the Mineral Joe channel was made and shows that the samples obtained extend across the entire width of the ore body.

Work was continued on the vanadiferous clays. Present interpretation is that the clays (predominantly hydrous mica) are important precipitants of ore. Preliminary tests show that a hydrous mica from the vicinity of ore removes V^{+4} from solution, whereas a red "unfavorable" clay does not. Also, the vanadium associated with the clays is in two phases - as vanadium (IV) in the clay structure and as vanadium (V) oxide intermittently dispersed through the clay particles. One clay sample from the Virgin mine in Long Park contained a small proportion of vanadium (III).

The work will continue chiefly on (1) mineralogic and chemical changes as evidenced by the channel samples, (2) continuation of the study of the vanadium clays with emphasis on the relation of clay type to removal of vanadium from solution and the determination of the rôle of the clays in ore precipitation, and (3) summary and interpretation of the chemical data on the solubility of uranium and vanadium in solutions resembling natural waters and (4) laboratory studies on the oxidation rates of low valence uranium and vanadium minerals.

Mineral synthesis

by G. Jansen, G. Magin, and R. Marvin

The solubility and phase equilibrium study of zircon in acidic and basic media was continued over the past six months. During this period crystalline zircon was successfully grown in an acidic medium. Experiments in which UO_2 and ThO_2 were added to the media are in progress in an effort to introduce these ions into the zircon lattice and to determine their location.

The investigation of the $K_2O \cdot V_2O_5 \cdot H_2O$ system was completed and the data put into report form. A study of the $CaO \cdot V_2O_5 \cdot H_2O$ system is underway. To date, ten crystalline phases have been found. The phase $V_2O_5 \cdot H_2O$ precipitates from calcium vanadate solutions having a pH less than 3. Hewettite and pascoite crystallize from solutions the pH of which varies from 3 to 6.5. The other phases (including rossite) appear above pH 6.5.

A study of the solubility of carnotite at various temperatures and hydrogen ion concentrations was initiated.

Synthetic crystals of several vanadium compounds were prepared for X-ray studies.

Isotope geology and nuclear research, Washington
by F. E. Senftle

Geochronology

The 6" solid sample mass-spectrometer tube is in operation and the first suite of lead samples from the San Juan Mountains, Colorado, is being analyzed on this instrument.

Nine specimens of uranium ore were prepared and submitted for age determination and twenty-six specimens of galena were prepared for isotopic analysis. Chemical analytical work was completed on seventy-seven samples, and forty-four samples of lead iodide were prepared. The mass-assay laboratory at Oak Ridge reported the isotopic analysis on twenty-six samples of lead iodides.

Infrared analysis of "coffinite," a new tetragonal uranium mineral, definitely shows the existence of an OH bond in the material. Apparently the $(OH)_4$ substitutes serially for (SiO_4) with the formula $U(SiO_4)_{1-x}(OH)_4x$.

Light-mass analysis

A light-mass spectrometer was put into operation for the measurement of hydrogen-deuterium isotope ratios in gas samples. The hydrogen-deuterium gas samples were prepared in a vacuum train by passing water vapor over hot zinc. After adjusting the spectrometer to obtain the highest possible resolution, standard gas samples were prepared and the instrument was calibrated. While measurements are made in reference to an arbitrary standard, it is possible to calculate from the standard gas samples absolute isotope ratio values if they are needed.

The analysis of H/D ratios of sea water samples was attempted first in order to test the reproducibility of the measurements. The H/D ratio

of sea water varies by only several tenths of a percent and therefore high resolution must be obtained in the measurement, and fractionation during sample preparation must be avoided. Duplicate results of H/D ratios were determined on several dozen sea water samples. The samples were obtained from three widely separated oceanographic stations in the Atlantic Ocean. The results at each of the three stations followed a similar trend but the isotope ratios were found to differ slightly from one station to another with depth. These results are being interpreted in cooperation with scientists at the Woods Hole Oceanographic Institution so that a knowledge of the hydrographic data can be applied to the study. It appears that the results will be useful in tracing water masses and in studying problems in the evaporation of sea water. Rain water and glacial water are relatively light in deuterium. Local variations due to introduction of such waters into the sea can be detected and measured. Evaporation on the other hand renders sea water heavier in deuterium.

In an effort to determine the deuterium isotope fractionation in brackish and natural waters a cooperative study was undertaken with the Woods Hole Oceanographic Institution in studying the deuterium exchange in the Lake Maracaibo area of Venezuela. The values of H/D were determined for fifteen brackish and fresh water samples from this area. Since the ratios vary by several percent, the determination of the ratios offers less difficulty than sea water samples. Preliminary calculations show that total evaporation, calculated on the basis of the H/D ratios compares favorably with that calculated from the hydrographic and meteorological data.

Several rock samples were ignited to remove associated water so that it could be processed to prepare hydrogen-deuterium gas for its subsequent isotope ratio determination. The preliminary results are being examined from the viewpoint of gaining information concerning the origin of the rock.

Portable mass spectrometer

A small, 2-inch radius mass spectrometer was acquired from the Department of Terrestrial Magnetism. It is planned to mount this instrument in a truck to make "on the spot" total gas analyses of fumerole gases.

Investigation of natural processes

As a result of the spectrographic analysis of one of the uranium-vanadium ores for geochronology it was noticed that a very small percentage of chromium was present. The association of vanadium and chromium, and the fact that vanadium has a large neutron cross-section, suggested the possibility that the chromium was formed by decay of vanadium. If this were true, the isotope analysis of chromium would show an abnormal abundance of Cr⁵². Accordingly work is proceeding to extract the chromium for an isotope analysis.

A small amount of exploratory work is being conducted on the adsorption of radioactive cesium ions on quartz crystals. A number of synthetic quartz crystals have been obtained for this purpose. Autoradiographs of the synthetic crystals indicate that the natural crystals have greater adsorption properties. This work is being continued.

Isotope geology of lead and related investigations
in cooperation with the California Institute of Technology
(geochemical laboratory)
by R. S. Cannon, Jr.

A plan to test the nature of primeval lead on the earth by searching for primitive types of lead in terrestrial materials is in progress. Work is well along on three samples of rocks that may have originated deep in the earth's mantle (dunite bomb from Hawaii and its matrix of basaltic lava, terrestrial troilite from California, and anorthosite from the Adirondacks, N.Y.) and on three very well preserved though extremely old supracrustal rocks (pillow basalt, algal limestone, and graphitic slate) from the Bulawayan System of Southern Rhodesia. Petrographic study (Neuerburg) and physical preparation (Neuerburg, Patterson) of these sample materials was completed, and chemical extraction of lead for isotope analysis is now in progress. (Patterson). Arthur Holmes recently published (Nature, April 3, 1954) Pb/U/Th isotope age determinations for two monazites from post-Bulawayan pegmatites of Southern Rhodesia that show the Bulawayan samples to be older than 2.65 billion years. Holes also notes that these age determinations taken in conjunction with evidence of life in Bulawayan time (algal structures and organic matter in two of our samples) imply that life existed on the earth for more than 2.65 billion years. In another quarter, a team of scientists at the Geophysical Laboratory of the Carnegie Institution of Washington is engaged in an investigation on the isotopic composition of lead in dunite bombs from California.

Petrographic and mineralogic research is being carried forward, especially study and evaluation of potential sample materials. In addition to those mentioned above, the Chishawasha granite of Southern

Rhodesia was found to be an exceptionally suitable old granite (2,650 m.y.) for isotope and age studies. Petrographic and chemical evaluation of our suite of post-Pleistocene basalts from the Snake River Plain of Idaho is being completed, and six plutonic rocks from the pre-Cambrian basement of the Uncompahgre Uplift in Colorado were studied with the microscope to implement work that Patterson has in progress on related samples. Neuerburg also completed petrographic study of a rutile-bearing kalsyenite in the Boulder batholith of Montana. Following evidence from CIT, X-ray spectrograms that the crystal structure of terrestrial troilite may be identical with meteoritic troilite but slightly different from samples of pyrrhotite, a suite of a dozen "pyrrhotites" ranging widely in ferromagnetic susceptibility was assembled and prepared for X-ray diffraction study to test this phenomenon more systematically.

A note by Neuerburg and Gottfried (TEM-709) on the age of zircon from the borders of the San Gabriel anorthosite massif of California, gives the first specific evidence that this anorthosite also may conform with the broad generalization that andesine anorthosite massifs are of pre-Cambrian age. The authors conclude further that these data "provide a first age determination on the pre-Cretaceous crystalline rocks of the San Gabriel Mountains and point to the existence of pre-Cambrian rocks near the edge of the Continental Shelf." Neuerburg and Gottfried collected and are preparing a suite of supplemental samples from the plutonic rocks of the San Gabriel and Santa Monica Mountains for zircon age determinations.

Examination of a sample of radioactive gneiss from a large anomaly in the Blue Ridge of Virginia shows that the most prominent radioactive accessory mineral is monazite. Observation suggests that the radioactive

anomaly may be caused by a concentration of thorium in this rock and extends the known geographic distribution of monazite in the crystalline rocks of the Southern Appalachians by some miles northwestward. The locality recently was revisited and a sample of the most radioactive gneiss (estimated of the order of 0.01% eU) collected for age studies on the radioactive accessory minerals. The radioactive rock is the pyroxene granodiorite of the Blue Ridge anticlinorium and appears superficially to resemble the pyroxene quartz syenite gneisses of the New Jersey Highlands and the Adirondacks. Here for the first time it appears possible to date one occurrence of monazite in the crystalline rocks of the southeastern States by direct stratigraphic evidence, for this monazite-bearing pyroxene granodiorite locally forms the basement on which the Catoclin basalts were extruded, almost certainly in late pre-Cambrian time.

Recent work on isotope geology of lead in lead minerals and ores included the collection and physical preparation by Silver (CIT) and Cannon of a small suite of galenas from the Sudbury district, Ontario. Because the geologic occurrence of the samples is known, their analysis may clear up the mystery of the "anomalous" leads of the Sudbury district. New isotope data obtained during the past six months include 11 analyses of lead from galena of the Upper Mississippi Valley lead-zinc district and of the southeast Missouri lead belt. Four samples cut from a cubic crystal (2 cm^3) of galena from the latter area do not prove the existence of any systematic variations within the crystal, although the samples do vary considerably in composition. Likewise three samples from a galena metasome replacing limestone (northern Illinois) do not reveal systematic variations related to growth layers. Interpretation of minor variations among

these analyses is plagued by uncertainty about analytical errors, but the general nature of the lead in these galenas is evident. The kind of lead that has been found in the Tri-State district and referred to by many writers as the "Joplin-type of anomalous lead" occurs likewise in the other two major lead-zinc mining districts of the Mississippi Valley. This community of isotopic composition implies some common bond in geochemical history but does not so far conclusively identify the common factor. As can be seen in the tabulation of averaged analyses below, the lead in these Mississippi Valley ores does bear some resemblance in composition to the traces of lead that Patterson has isolated by chemical extraction and analyzed from 5 unmineralized and unmetamorphosed marine carbonate rocks ranging in age from Late pre-Cambrian to Pleistocene. This implication is being tested by further study.

Table 33.--Lead isotope analyses, averaged

Samples	Pb isotope ratios		
	206/204	207/204	208/204
7 galenas from one mine, Upper Miss. Valley	22.12	16.05	42.00
4 samples from one galena cube, S. E. Mo.	22.22	16.00	41.36
9 samples from one galena cube, Tri-State dist.	21.78	15.66	40.43
9 analyses from 5 different specimens, Tri-State dist., by Nier, Vinogradov	21.99	15.92	40.99
5 samples of lead extracted from limestones, by Patterson	20.48	15.49	38.63

Crystallography of uranium and associated minerals
by H. T. Evans

Crystallography of uranium oxide hydrates

Detailed lattice studies on the group of minerals of the type $n\text{UO}_3 \cdot m\text{H}_2\text{O}$, comprising schoepite, becquerelite, fourmarierite, billietite,

and others, was undertaken preparatory to a structure investigation. Much of the work by Judith Weiss Frondel on this group, in particular her observation of the close crystallographic similarities among the members, was confirmed. The unit cells are all based on a small hexagonal pseudo unit corresponding to the hexagonal unit cell of α -UO₃. Thus, the orthorhombic cell of schoepite contains 32 of these pseudohexagonal units, while becquerelite contains 24. It has been found that schoepite (and probably others) splits into two closely related phases, apparently with slightly different water content, with one altering readily into the other on warming or irradiation.

New developments in methods of crystal structure analysis

Much time was devoted to testing a new method of deriving the structure of any centrosymmetric crystal directly from the diffraction data without the indirect intermediate steps which have almost always been necessary up to now. The method, which was developed by J. Karle and H. Hauptman of the Naval Research Laboratory, was exhaustively applied to the structure of colemanite (2CaO·3B₂O₃·5H₂O) and proved to be completely successful. The work involved the setting up and carrying out a computing program of moderate size, making use of USGS and Bureau of Standards IBM installations. The last stage in the work consisted of calculating the electron density at 54,000 points in the unit cell of colemanite, by summing at each point a series containing about 1,000 independent terms. This electron density synthesis revealed the entire structure in all detail for the first time. The main advantages gained for the work from this development lie in the facts that the new method now makes it possible to solve crystal structures

by routine methods regardless of complexity, and new and rapid computing techniques have been developed which will greatly facilitate this work in the future. By taking the intuition and guesswork out of crystal structure analysis, and thereby removing completely the severe upper limit on the complexity of structures that could be solved before now, the Hauptman-Karle method promises to introduce a new era in the field.

Compilation of crystallographic data on phosphate minerals

Mainly through the initiative of M. E. Mrose, tables are now nearly ready for the determination of the iron-manganese phosphate minerals by X-ray powder diffraction methods. Data were collected for all the known members of this group (about 80), in large part by the measurement of original patterns. The tables will be organized in a system similar to that of the ASTM card file. This report will form a section of the projected complete compilation of the powder diffraction, single crystal and optical data for all the phosphates, arsenates and vanadates.

Papers and publications by project members

Papers given at the American Crystallographic Association in Cambridge, Massachusetts, in April were the following:

- H. T. Evans, "The crystal structure of a molybdotellurate complex."
 C. L. Christ, J. R. Clark and H. T. Evans, "The structure of colemanite, $\text{CaB}_3\text{O}_4(\text{OH})_3 \cdot \text{H}_2\text{O}$, determined by the direct method of Hauptman and Karle."

The following papers have been issued for publication:

- C. L. Christ, J. R. Clark and H. T. Evans, Jr., "Crystal structure of potassium metavanadate monohydrate, $\text{KVO}_3 \cdot \text{H}_2\text{O}$," TEI-406, Feb. 1954; Acta Cryst. in press.

- C. L. Christ, J. R. Clark and H. T. Evans, Jr., "The structure of colemanite, $\text{CaB}_3\text{O}_4(\text{OH})_3 \cdot \text{H}_2\text{O}$ determined by the direct method of Hauptman and Karle," *Acta Cryst.* in press.
- C. L. Christ, E. J. Dwornik and M. S. Tischler, "Crystalline regions in metamict minerals," *Science* 119, 513 (1954).
- J. D. H. Donnay and G. Donnay, "Syntaxial intergrowths in the andorite series," *Am. Min.* 39, 161-171 (1954).

Radon and helium studies
by G. B. Gott

The geological and analytical data previously acquired have been evaluated and compiled preparatory to beginning a summary report covering the work to date.

A detailed cross section of a strategic part of the Western Panhandle field has been constructed. The cross section shows a definite relationship of the radon in the gas-producing formation with "asphaltite" and asphaltic material.

Additional structural information relative to the areas where the helium is most concentrated indicates that the helium occurrence has been influenced by faulting.

A study of the paragenesis of the rock-forming minerals of the "Big Lime," "Brown Dolomite," and "Moore County Lime" indicates that the "Big Lime" dolomite is probably primary, whereas the "Brown Dolomite" is probably secondary. The anhydrite of the "Big Lime" appears to replace the dolomite, but the anhydrite of the "Brown Dolomite" is replaced by dolomite. "Asphaltite" replaces both dolomite and anhydrite in all formations. Silicification and pyritization are later than dolomitization. The "pinpoint" porosity of the "Brown Dolomite" in which some of the "asphaltite" occurs, can be

attributed to the removal of anhydrite. The uraniferous "asphaltites," therefore, were deposited near the end of the paragenetic sequence.

Chloanthite-smaltite, $(\text{Ni}, \text{Co}) \text{As}_2$, have been identified in 14 samples of asphaltite and xenotime, uraninite(?) and erythrite(?) were identified in one sample. All of the "asphaltite" samples are graphitic.

Thermoluminescence curves have been run on a few samples of dolomite from the gas-producing formations in the Panhandle field. The dolomite showed a more intense luminescence than "normal" dolomites and limestones.

Additional data have been obtained on the arsenic and cobalt content of spent acid residues from acidization of Panhandle field gas wells. The results show that the reservoir material leached by the first acidization was rich in As and U and poor in Ca and Mg. Dolomite was the principal material leached during the second and third acidizations.

A porphyrin determination of a crude oil (Mudget No. 1) in the Panhandle field by the U. S. Bureau of Mines showed that the oil contains 8 ppm of non-surface active porphyrins. The surface activity of the oil was found to be negligible.

It has been found by Dunning of the U. S. Bureau of Mines that the "asphaltites" from surface rocks in the Wichita Mountain areas are insoluble in a mixture of glacial acetic and hydrobromic acids. These "asphaltites" are similar in all respects to those in the Panhandle field.

Gas samples from fifteen selected wells in the Panhandle field were collected and sealed in glass in the field. One cut of each sample was sent to A. O. Nier, University of Minnesota, to Harmon Craig, and to Gerald Wasserburg, both at the University of Chicago, for isotopic abundance determinations of helium, carbon and oxygen, and argon, respectively. Another sample is being prepared for H. G. Thode, McMaster

University, Hamilton, Ontario, for xenon isotopic abundance determination. The results of these determinations are expected to be of value in determining the past history of the gas and its association with radioactive elements.

MINERALOGIC AND PETROGRAPHIC SERVICES AND RESEARCH

Services

Mineralogical services, Washington
By E. J. Dwornik

Public sample program

Approximately 650 samples submitted to the laboratory were analyzed for radioactivity during this period. Significant radioactivity in 17 per cent of these samples necessitated more detailed mineralogic, X-ray, chemical and/or spectrographic analysis.

Special sample program

Seventeen reports entailing mineralogic, spectrographic, and sieve and size analyses, and weight percent determination of heavy mineral concentrates were prepared for field geologists engaged in radioactivity reconnaissance.

Investigation is being continued on the rare-earth bearing phosphate from Essex County, New York. X-ray diffraction patterns show a structure similar to strontian apatite. Indices of refraction are higher than those previously reported for specimens of the apatite group.

A report concerning the laboratory processing of the 4500 samples analyzed for the Southeast Monazite Project was written.

A reconnaissance of the National Museum collections for radioactive specimens was completed. Seventy-nine samples showed significant radioactivity and were selected for additional radioactivity, chemical and mineralogical analysis.

Mineralogical services, Denver
By L. B. Riley

The samples submitted for identification and study at Denver are from reconnaissance groups or directly from AEC offices in Denver and Grand Junction. The majority are fine-grained aggregates, especially clays and secondary uranium and associated minerals for which the X-ray powder diffraction and X-ray diffractometer techniques are well suited. During this period 457 diffraction photographs and 353 diffractometer analyses were made. In addition 32 minerals and mineral assemblages were given detailed study by optical and other methods. Also during this period the number of reference minerals and standard X-ray patterns was greatly increased.

Preliminary studies on yellow uranium minerals submitted from the Wind River, Wyoming area indicate an arsenic-phosphate environment. Preliminary studies on one of these samples indicate that a low-calcium uranospinite (possibly troegerite or hydrogen uranospinite) is present. Another contains what may be unnamed calcium uranyl phosphate, with a small amount of associated arsenate. Neither of these specimens is suitable for an intensive study and it is hoped that better specimens can be obtained.

A sample with a fracture or joint-face coated with radium-bearing barite was submitted from the Black Hills, South Dakota, area. This had a high eU content but less than 0.1 percent chemical uranium. Similar material has been observed elsewhere, but such material helps to emphasize that percent eU is a measure of radioactivity and not necessarily a measure of uranium. It also shows one cause of high equivalent uranium disequilibrium, and one source for radon not directly associated with uranium.

A mineral closely resembling hewettite, but with no appreciable amounts of Ca, Na, or K, was found among the minerals from Monument No. 2 Mine, Monument Valley, Arizona.

Experiments on preparation of glasses with known uranium content indicate the feasibility of providing standards of such material for field radiometric assaying.

The investigation of potential uses of X-ray fluorescence analysis for certain types of samples was started this period. In general this investigation follows the general development of this technique by the Washington laboratory. Among the advantages of this method is that the sample is not destroyed during analysis. Preliminary results indicate that samples containing above 10 ppm selenium may be analyzed. Methods for arsenic are also being considered.

The X-ray techniques of this laboratory have also been applied to study certain problems related to the analytic determination of uranium by the photo-fluorescence produced in fluxes of sodium fluoride, sodium carbonate, and potassium carbonate. The results indicate that the cooling history and crystalline state of this flux are at least partly related to the amount of fluorescence produced.

X-ray services
By G. E. Ashby

This report tabulates the service work performed with only brief reference to problems of special interest.

Samples and services

Number of requisitions	318
Number of samples	536
Number of determinations	644

C. L. Christ in collaboration with E. J. Dwornik and M. S.

Tischler showed that metamict zircon, as defined by weak birefringence and poor X-ray pattern, will give sharp electron diffraction patterns. This was reported in the April 12 issue of Science in a paper "Crystalline regions in metamict minerals."

Electron microscopy
By E. J. Dwornik

The work involves (1) the routine examination and identification of fine-grained materials using both electron diffraction and electron microscopy, and (2) special research which includes (a) electron diffraction studies of metamict minerals, (b) electron microscope and diffraction studies of vanadium minerals from the Colorado Plateau, and (c) the devising of new techniques of sample preparation.

Routine work includes examination and identification of clay samples, diffraction studies and examination of deep-sea core samples, carbonaceous pellets and secondary uranium minerals.

Both routine work and special studies were greatly enhanced by the installation of a "selected area diffraction unit". This unit permits electron diffraction patterns to be made of material as viewed within a selected area of a sample mounted in the electron microscope. The advantage gained thereby is that identification of material seen with the electron microscope can be definite as based on the diffraction pattern of a particular mineral species, rather than by characteristic morphology.

In view of the fact that standardization procedures have not yet been established in the field of electron diffraction study, it is essential that efforts be directed toward testing reproducibility of patterns and determining optimum methods of sample preparation. Therefore samples were prepared and patterns studied to check the effect of particle size, dispersion, and various metallic and organic supporting films.

Preliminary examination of metamict minerals using electron diffraction indicates that the method may prove valuable in studies of the metamict state. Work to date has been confined to study of zircon in various stages of metamictization and future work will be extended to cover other metamict minerals.

Continued studies of mineralized and unmineralized hydromicas (vanadium mineralization) using selected area diffraction show the presence of but one phase (hydromica) rather than two (hydromica plus vanadium oxide) as previously suspected.

In total, 485 electron micrographs and 105 electron diffraction patterns have been made during this six-month period.

Research

Research on methods and techniques
in mineralogy and petrology
By E. J. Dwornik

Comparison tests were made to determine the relative efficiency of the cone splitter, Otto microsplit, and hand quartering. Samples used in these studies were made up of a known number of grains of quartz, ilmenite, and monazite in predetermined ratios so that the accuracy of the splitting operation could be assessed. An analysis of variance of a preliminary

design, using splitting methods and sample weights as the two classifications, indicated that there is a significant difference between the results obtained with the microsplit and the other two methods. From these initial experiments it becomes evident that further work should be devoted to a study of laboratory sampling in general.

The problem of heavy liquid separation of relatively large quantities of crushed igneous rocks (1-3 kilograms) containing a relatively low concentration of heavy minerals was simplified by the construction of a separatory vessel that permitted the operator to tap off the heavy concentrates and skim off the light fraction periodically without recharging the system.

A flotation method for separating pyrite from zircon was devised using isopropyl xanthate (American Cyanamid reagent #343) as a pulp conditioner. Repeated washings accompanied by removal of the pyrite yielded 95 percent pure zircon concentrates.

A new magnetic separation technique was developed for removing fine grained magnetite from other minerals. Approximately 1 gram of sized sample is placed in a Petri dish which is set on a commercially available magnetic stirrer. With the rotating magnet in operation magnetite grains concentrate at the center whereas the less magnetic minerals are thrown out tangentially. Magnetite is then easily removed by a horseshoe magnet held over the rotating grains.

Wilfley tables are being used to concentrate heavy minerals from large samples of crushed rock (20-50 lbs.). Advantages of this method of concentration over conventional bromoform separation are: (1) screening out of fines is not necessary as the tables do the desliming, and (2) heavy

minerals as fine as -400 mesh are recovered from an initial sample sized only on a 100 mesh sieve.

In the thin section laboratory, work is continuing on a moderately successful technique for low temperature impregnation of friable and porous specimens using synthetic media.

Properties of uranium-bearing minerals
By J. C. Rabbitt

During this period chemical analytical work was completed on pure samples of a hydrated uranium oxide from North Wilton, N. H., closely related to fourmarierite and vandendriesscheite; a similar phase from Mitchell County, N. C., probably related to fourmarierite; a lead-bearing variety of clarkeite from Rajputana; a probable carbonate from Morogoro, Tanganyika; diderichite of Voes, from Katanga; synthetic liebigite prepared by Alice Weeks; and synthetic diderichite prepared by Clifford Frondel. Complete semi-quantitative spectrographic analyses were made of these samples before the chemical analysis. X-ray diffraction patterns of the diderichite from Katanga, the synthetic diderichite, and the "green uraninite" previously described (see TEI-390, p. 265) are the same.

A procedure for the simultaneous determination of CO_2 and H_2O content of minerals is being developed and was applied in the above analysis of the hydrated uranium carbonate minerals. The apparatus used is a modified micro-combustion train of the type used for the determination of carbon and hydrogen in organic compounds. The sample is decomposed by ignition at 900°C in a stream of oxygen.

A study of the properties of voglite and uranosphaerite was completed by Robert Berman at Harvard University. Berman has begun studies of the supposed manganese-autunite called fritscheite (an authentic specimen was brought back from Europe by Clifford Frondel) and natural fully hydrated zeunerite.

Judith Frondel, with Michael Fleischer, is preparing a new revised edition of "A glossary of uranium- and thorium-bearing minerals", (Geol. Surv. Circ. 194). Circ. 194 was reprinted in May, the edition was exhausted, and another reprinting was requested.

The status of certain reports by members of the project is as follows:

TEI-367, "Studies of uranium minerals: An alteration product of ianthinite", by Judith Weiss Frondel and Frank Cuttitta was approved for publication in American Mineralogist.

A report on renardite by Clifford Frondel and Frank Cuttitta was sent to American Mineralogist for publication.

GEOPHYSICAL PROSPECTING SERVICES AND RESEARCH ON METHODS

Development and maintenance of radiation
detection equipment

By W. W. Vaughn

Considerable time was spent setting up new procedures for standardizing more rigidly the gamma-ray logging equipment. The construction of several more rate-meters, as well as a few modifications of existing units, are planned for next fiscal year.

An instrument for studying thermoluminescence of rocks (TEI-390) was completed and has been in operation for six months. The luminescence of the rock sample is plotted automatically against temperature and large anomalies may be observed with small samples of rock. One-gram samples of ground glass exposed to x-radiation gave full scale deflection. The thermoluminescence unit may prove to be a valuable tool in the study of samples taken from strata through which uranium-bearing materials have migrated.

An electronic circuit (see fig. 42) for carborne and light airborne scintillation counting was designed, built and tested. The circuit is a modified total intensity type; that is, the meter reading is somewhat dependent on the energy of the gamma-rays but not directly so. The upper energy limit is gated to prevent large fluctuations caused by cosmic showers. The circuit is designed for use with a 3 in. diameter by 1-1/2 in. thick NaI crystal and a 3 in. photomultiplier tube. A regulated high voltage power supply is included which is adjustable from 960 volts to over 1400 volts with a regulation of better than one percent. This makes possible the use of the DuMont type #6363 three-inch-diameter phototube. The circuit drives a 1 Ma. Esterline-Angus strip chart recorder. Power is taken from the 6 or 12 volt

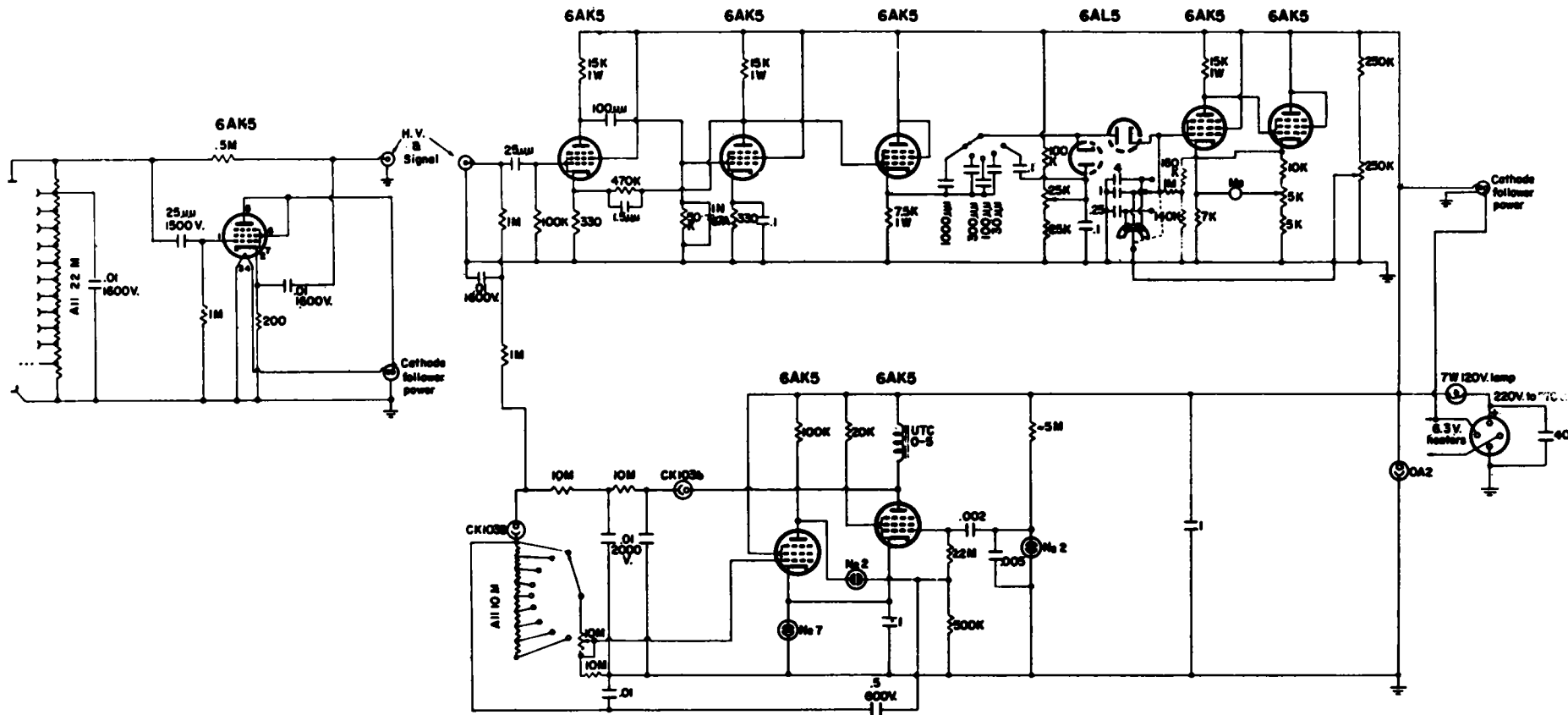

FIG. 42--SCINTILLATION COUNTER FOR CARBONE APPLICATION.

electrical system of the car or plane. Fifteen of these instruments are being contracted for at the present time.

Laboratory tests of the instrument showed a statistical fluctuation of about 12 percent in a .025 mr/hr field of gamma radiation with a one second meter time constant. Side by side tests with the Oak Ridge designed equipment in the DC-3 aircraft showed a response of about one-half that of the Oak Ridge equipment at altitudes of 100 to 500 feet over the 40 by 40 foot ore slab at the Grand Junction, Colorado Airport. A commercially produced model of this instrument was tested in the Laboratory; only minor modifications were necessary to make the instrument operationally sound.

A pulse generator to aid in the routine adjustment of the gamma-ray logging (Barnaby) ratemeter was designed in the Denver Laboratory and constructed in Grand Junction. This unit produces pulses at six fixed rates, synchronized with the 60 cycle power line. These are 360, 720, 3,600, 7,200, 36,000, and 72,000 pulses per minute, which will make it possible to align and check the ratemeters at two points on each of the scales normally used.

A simple, reliable bell-ringing circuit to be attached to a portable scintillation counter was designed and constructed. With this attachment it will be possible for a single operator to use a portable hand scintillation counter for car traverses. The alarm can be set to ring at any given intensity level, thereby freeing the operator to concentrate on driving.

All modifications of the gamma-ray logging (Barnaby) ratemeter were completed. Data from the simulated drill holes in Grand Junction show the total maximum instrument error to be 8 percent. In reality the probable instrument error will be approximately 3 percent as applied to the interpretation of logs.

By incorporating the RCA 931-A photomultiplier tube with the total intensity scintillation meter developed in the Laboratory last year, an inexpensive, small and effective portable scintillation counter can be built. If constructed by a competent manufacturer, the sensitivity of this instrument could approach that of the other portable scintillation counters presently available.

A core-scanning device was designed using four photomultiplier tubes viewing approximately four liters of liquid phosphor in the form of a six-inch outside diameter right cylinder with 2-3/8 inch axial cylindrical void. The instrument will be attached to a ratemeter (E. K. Cole Model 1037A) and a graphic recorder for continuous scanning of drill cores. The instrument should permit grade cutoff with a probable error of 4 percent.

Tests have been made on a commercially built prototype of the electronic assembly of a portable scintillation logging unit. After a number of parts had been exchanged and the circuit adjusted, the prototype operated satisfactorily. Bids on approximately 12 of these instruments will be requested.

Experiments will be made during the next reporting period on induction and dielectric heating of the furnace for the thermoluminescence unit. Other experiments will be made on a photoelectric potentiometer, which in effect is a self-positioning potentiometer. This instrument, having an input impedance approaching infinity, would be designed to measure accurately potentials on the order of a few microvolts, without disturbing the source being measured.

A high-sensitivity scintillation logging unit will be constructed, contingent upon the availability of suitable photomultiplier tubes, DuMont type 6467.

Airborne radioactivity surveying

By R. M. Moxlam

Airborne radioactivity surveys were undertaken in seven states and totalled 24,040 traverse miles (see fig. 45).

The data obtained during experimental flights over the simulated ore deposit at Grand Junction have been reduced and the results prepared for machine computation. It is anticipated that sufficient information will be obtained to permit at least semi-quantitative interpretation of airborne radioactivity records. The data obtained by the numerical computation will also be applicable to other problems relating to gamma-ray scattering and absorption. Additional information regarding this work is given in the section on Gamma-ray scattering and absorption.

Areas surveyed

The areas surveyed from December 1, 1953 through May 31, 1954 are shown on figure 45 and are listed below:

<u>State</u>	<u>County</u>	<u>Area</u>	<u>Traverse miles</u>
Arizona	Navajo	Painted Desert	5,300
	Coconino		
	Apache	Pinto-Chinle	6,520
California	San Bernardino	Kramer	1,500
	Florida	Ft. Myers	2,500
Lee			
	Sarasota	Gardner	1,300
	Charlotte		
	Sarasota		
	Manatee		
	Hardee		
	DeSoto		

Georgia	Appling Tattnall Toombs Charlton	Altamaha	600
		Folkston	140
South Carolina	Berkeley Charleston	Edisto Island	1,560
South Dakota	Pennington Washabaugh Washington Jackson	White River Badlands	900
	Custer	Black Hills	1,520
Utah	Washington	Arizona Strip	<u>2,200</u>
	TOTAL		24,040

Painted Desert area

The Painted Desert survey covered approximately 1,325 square miles underlain primarily by the Chinle and Shinarump formations. Twenty-three anomalies were detected, the majority in the northwestern part of the surveyed area. Several represent producing mines, prospects or other previously known deposits, but at least fourteen are thought to be new localities. All are in the Chinle formation. Of those which have been ground checked to date, ore grade material has been found at only one. The results of the Painted Desert survey are being prepared for public release.

Pinto-Chinle area, Arizona

The Pinto-Chinle area is underlain chiefly by the Chinle and Shinarump formations. Only one anomalous locality was recorded. Ground investigation showed the source to be a radioactive sandstone lense at the base of the Chinle but it is doubtful if any material of ore grade exists at this location.

FIG. 43--AIRBORNE RADIOACTIVITY
SURVEYS, DEC. 1, 1953 - JUNE 1, 1954.

(See page 249)

Kramer area, California

Radioactivity measurements were made in conjunction with an aeromagnetic survey. No radioactivity anomalies were recorded.

Fort Myers and Gardner areas, Florida

The Florida surveys were undertaken to obtain additional information on the applicability of airborne methods to the location of phosphate deposits. Several low-amplitude anomalies were detected in the Gardner area. One anomaly located in the extreme southwestern corner of Hardee County was investigated by auger drilling. Two holes, drilled about 1/4 mile apart penetrated pebble phosphate deposits ranging from 15 to 20 feet in thickness, buried at depths of 30 to 40 feet. Samples of the material are being processed to evaluate the economic possibilities. Further examination of the airborne records is in progress.

Altamaha area, Georgia

The survey was undertaken as a reconnaissance of potential phosphate areas. Slightly anomalous radioactivity was detected generally throughout the Altamaha Valley, probably as a result of small amounts of river pebble phosphate in the Altamaha River alluvium. Several localities on the highlands immediately north of the river appeared from the air to be slightly radioactive.

A brief ground investigation was made during which one drill hole was put down in the highland area. No phosphate or other significantly radioactive material was found.

Folkston area, Georgia

Experimental flights were made over an elevated beach placer deposit containing thorium minerals, for the purpose of determining the behavior of the airborne equipment with respect to such source materials. The results indicate that, under proper conditions, the high beach placers can be found by the airborne method.

Edisto Island area, South Carolina

The southeastern coastal plain of South Carolina, in which the Edisto Island area is situated, was one of the world's important phosphate producing regions prior to the development of the Florida deposits. The purpose of the Edisto Island survey was to determine whether there was any surficial expression of possible occurrences of uraniferous phosphate.

Abnormal radioactivity was recorded at many localities. Those of maximum intensity occur chiefly along the shores of the Stono and Ashley Rivers in the north-central part of Charleston County, a few miles west and northwest of Charleston. A brief ground investigation showed that several of the anomalies were attributable to old pebble phosphate workings or tailings. However at other anomalous localities no evidence of previous working was found. In addition to the pebble phosphate occurrences, abnormal radioactivity was recorded over leached outcrops of the Hawthorn formation in the northeastern part of the surveyed area. Radiation measurements on the ground at one such locality indicates the material to be quite similar to the leached Hawthorn outcrops detected during airborne surveys in Florida (see TEI-387). A report on the results of the survey of the Edisto Island area is in preparation.

Black Hills area, South Dakota

The Black Hills survey included 1,520 traverse miles along the southern part of the Black Hills uplift. The area is underlain by rocks ranging in age from Pre-Cambrian to Cretaceous. Twelve anomalies were detected in rocks of various ages, ranging from the Deadwood (Cambrian) formation to the Pierre shale (Upper Cretaceous). One anomaly, according to field checking, resulted from probable ore-grade material in the basal Fall River (Lower Cretaceous) formation, apparently at the same horizon as anomalies which were detected over the Lakota Lode and Dark No. 1 claims. The remainder of the source materials were not of ore grade.

White River Badlands area, South Dakota

The White River Badlands are occupied by the White River formation (Oligocene). Very small anomalies were recorded over known mineralized localities in the western part of the area. No additional anomalies were found.

Arizona Strip area, Utah

The survey, which is now in progress, covers outcrops primarily of the Chinle and Shinarump formations.

Plans

During the next 6 months, surveys will be made as follows:

<u>State</u>	<u>County</u>	<u>Area</u>
Arizona	Mohave	Arizona Strip
Colorado	Moffatt	South Washakie Basin
Maine	Aroostook Piscataquis	Devonian belt
Montana	Blaine	North Bearpaw Mountains
Oklahoma	Comanche	Wichita Mountains
Pennsylvania	Monroe Carbon Lucerne	Mauch Chunk
Utah	Duchesne Uintah	Myton
Wyoming	Converse Niobrara	Pine Ridge Escarpment
Alaska		Mt. Fairplay Tyonek Yakataga Lost River Ear Mountain Peace River - Candle Nixon Fork Circle Copper Creek Chicken

The areas listed above are shown on figures 44 and 45.

FIG. 44--AIRBORNE RADIOACTIVITY SURVEYS
SCHEDULED, JULY - DECEMBER 1954.

(See page 250)

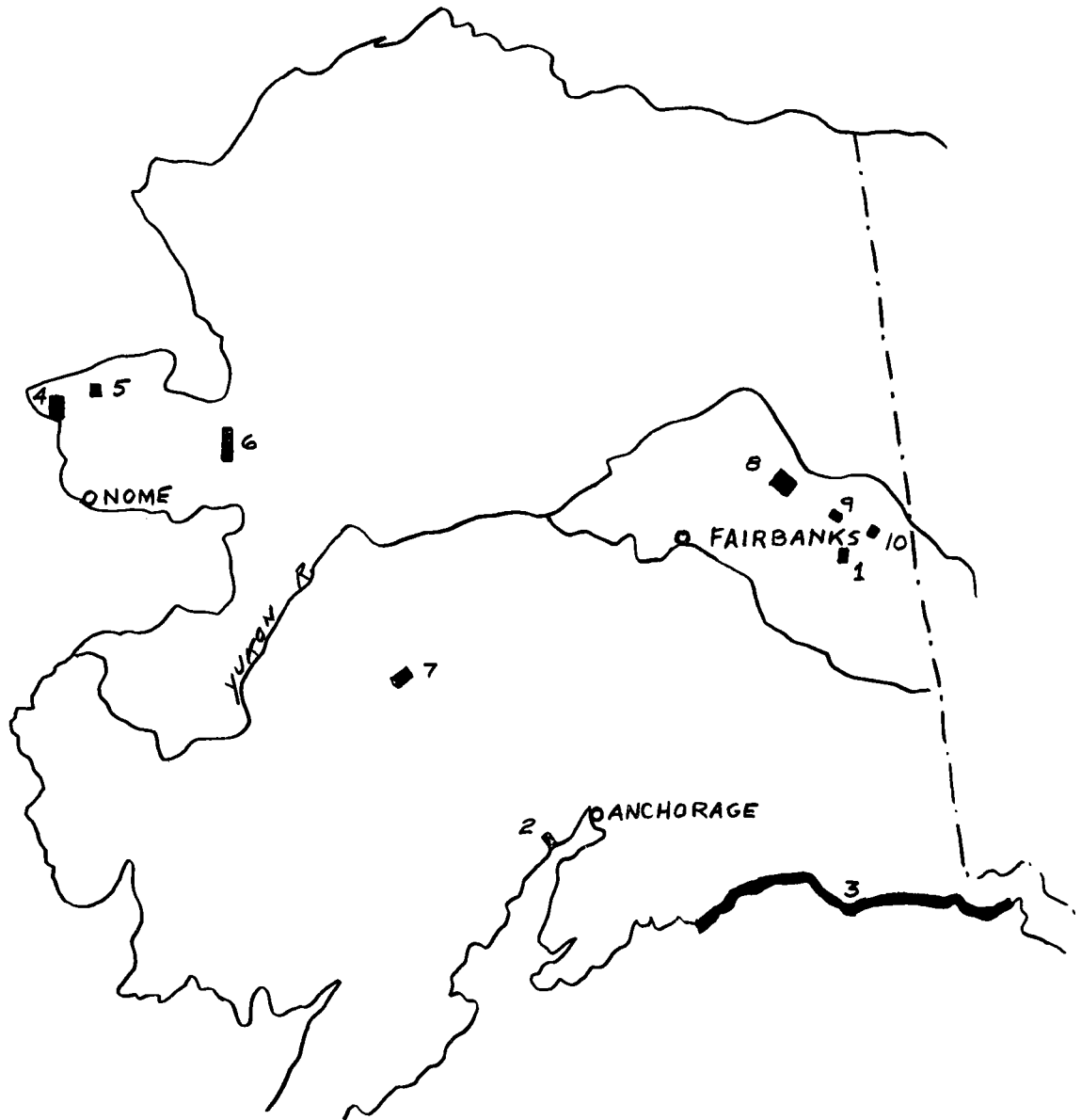

- 1 Mt. Fairplay
- 2 Tyonek
- 3 Yakataga
- 4 Lost River
- 5 Ear Mountain
- 6 Peace River - Candle
- 7 Nixon Fork
- 8 Circle
- 9 Copper Creek
- 10 Chicken

Fig.45.--INDEX MAP OF ALASKA SHOWING LOCATION OF AIRBORNE RADIOACTIVITY SURVEYS
June-December 1954

Physical behavior of radon

By A. S. Rogers

A study was made to determine the significance of the distribution of radon in a 1-1/2 mile reach of the Weber River near Ogden, Utah. The problem in essence was to determine whether the distribution of radon in the stream water, where a significant increase in stream volume occurs between stream gauging stations, could be related to influx of bed rock ground water along the stream course, or influx of bank storage water along the stream course, and whether the influx between the gauging stations was continuous or localized. The results and conclusions are:

1. The increase of stream flow occurs at three areas which are related to the three thrust faults in the area.
2. The increase in stream flow is apparently due to the influx of bed rock rather than bank storage ground water.
3. Calculations, based on the radon content in stream waters and visible spring waters, were made to determine the amount of ground water influx into the stream at each area of increase. The results account for about 60 percent of the increase.
4. The loss of radon from the stream waters of the Weber River area occurs as an exponential function with respect to distance of stream flow. This confirms similar behavior in streams previously investigated.

Absorption and scattering of gamma radiation

By A. Y. Sakakura

Experimental and theoretical phases of the work were continued.

Experimental

Cylindrical geometry experiments (simulated drill hole)

A 6 x 6 x 9 foot water tank has been constructed by the Bureau of Reclamation in Denver so that the measurement of radiation intensities within cylindrical cavities of various diameters can be carried out. The electronic circuitry has been completed and tested, and the experimental work is now underway.

Plane geometry experiments

A report on the status of the calibration of the Survey's airborne equipment is completed. Tentative conclusions reached to date indicate that the behavior of the airborne equipment with respect to two basic source geometries (a point and a semi-infinite plane) are as follows:

Point source

$$I = 3.44 \times 10^7 \frac{S}{S_0} \frac{A}{A_0} \left(\frac{Z}{r}\right) \frac{e^{-\mu r}}{r^2} (1 + \mu r - .342(\mu r)^2)$$

Semi-infinite plane source

$$I = 3.44 \times 10^7 \frac{S \pi e^{-\mu Z}}{S_0 A_0} (1 - .342 \mu Z)$$

where r = air distance

S = grade of source

S_0 = grade of standard = .35%

A = area of source

A_0 = area of standard = 1600 sq. ft.

I = intensity in counts/second

μ = 1.246×10^{-3} ft.⁻¹ Grand Junction

1.461×10^{-3} ft.⁻¹ Sea level

(corresponds to 2.452 mev)

Z = vertical distance above source

Flights over the semi-infinite plane source (a flat mesa near Fruita, Colorado capped by Mancos shale) show that $\frac{S}{S_0 A_0} = 2 \times 3.44 \times 10^7 = 638$, from which we find $S = 1.7 \times 10^{-3} \text{ eU}$. Laboratory analyses of three samples indicate the Mancos shale to contain $1 - 2 \times 10^{-3} \text{ eU}$ in sample. The agreement is excellent.

Computations for various source configurations, based upon the results of the experimental flights will be accomplished by an electronic computer.

Theoretical

Investigations are now under way for formulating simplified problems for trial computation in the Univac. The isotropic scatter problem will be considered in detail so that the albedo can be determined in order that an estimate of necessary correction to the first iterant in the transport equation can be determined.

Gamma-ray logging studies By C. M. Bunker

Calibration of gamma-ray logging equipment

Modifications in the design of the gamma-ray logging equipment made to improve its stability and response to high intensity radiation, have necessitated recalibration of the instrument in order to determine accurately the grade in equivalent uranium and the thickness of radioactive material encountered in a drill hole. Two empirical calibration charts showing counts-per-minute, grade, and thickness have been completed. One chart has been released and will be used for the interpretation of gamma-ray logs made

between July 1, 1953 and the time when the second chart is released. The second chart will be released to coincide with the distribution and use of the modified ratemeters.

Experimental work with simulated ore bodies

A series of measurements in simulated ore holes were made to determine, empirically, the half-thickness of an ore-bearing sandstone. Other measurements were made to determine the effect of changes in bore hole size and ore zone thickness on the measurable gamma radiation intensity at the center of the ore body. These data were transmitted to A. Y. Sakakura for comparison with mathematical calculations of gamma ray scattering and absorption in cylindrical cavities.

Plans

In anticipation of a combined gamma-ray and electric logging unit, data from the two methods of measurement will be compiled to determine their combined value in predicting areas favorable for uranium mineralization.

Variation in background radioactivity within potential ore-bearing formations, as indicated by iso-radioactivity contouring based on gamma-ray logs, might outline in a general way areas favorable for further exploration; i.e., a higher-than-normal background throughout several feet of a formation might indicate highly disseminated radioactive material which had been leached from or is a halo around an ore body some distance away. Further investigation is planned to determine the applicability of this approach.

A comparison of gamma-ray logging data with chemical and radiometric analyses of core samples is planned in order to determine the amount of discrepancy between them and, if possible, to determine the source of error.

RESOURCE STUDIES

By W. S. Twenhofel, F. W. Osterwald, and R. L. Sutton

The Trace Elements Research and Resource Group now has specialists working on geologic and resource studies of uranium in sandstone-type deposits, vein-type deposits, phosphates, igneous rocks, natural waters, miscellaneous sediments, and hydrocarbons. Geologic and resource studies are also in progress on domestic thorium deposits. Geologists specializing in radioactive lignites and shales and in natural radioactivity are expected to join the Group within a few months. Six geologists are assigned to assist the senior specialists on a part-time basis.

A series of regular monthly meetings of the Research and Resource Group was initiated to enable members to exchange ideas, discuss new information and developments in the various field of uranium geology, and to hear experts, who are not associated with the Group, discuss subjects pertinent to the study of radioactive mineral deposits and resources.

Certain vein-type uranium deposits were examined in Texas, New Mexico, Arizona, and Nevada. A study was begun to determine the relationship, if any, between the major tectonic units in the eastern part of the Rocky Mountain region and the locations of known uranium deposits.

About 80 water samples were collected from streams in Florida, Georgia, and South Carolina; preliminary results of analyses of Florida water indicated several uranium anomalies, which suggest that the water sampling technique is effective in prospecting phosphate terrains. Locations of domestic occurrences of phosphate rock are being plotted on a base map in order to show areas which have been analyzed for uranium, and to aid in the study of variation in grade and geologic distribution.

A map showing the location and character of the principal uranium deposits of the United States is nearly completed, and a draft will be submitted in June. A thorium resource map and annotated bibliography of references to thorium deposits is being prepared.

Plans have been completed for the interchange of analytical data with other organizations, and with units of the Geological Survey, on the uranium content of igneous rocks. Arrangements have been made to analyze the highly alkalic rocks of Magnet Cove for uranium, which will supplement previous detailed minor element investigations on the same rocks. Samples of radioactive rhyolite from the Big Bend area in Texas have been received and will be analyzed for uranium in the near future.

Punch card filing systems were designed to facilitate the assimilation and quick availability of data accumulated on the subjects of uraniferous veins, igneous rocks, and sandstone deposits. It is planned that most of the published and unpublished reports on uranium will be catalogued so that correlations and significant relationships may be obtained directly from the files.

A revised section has been prepared on the geology of uranium deposits, to be used in a new edition of the booklet "Prospecting for uranium."

A punch card index to the uranium analytical file is being prepared. Under this system, analyses in the file may be found by locality, report number, name of collector, type of material analyzed, and contained elements. Two copies of each card are being made; one copy for use by the Geological Survey in Denver, and the other for use by the Geological Survey laboratory at the Naval Gun Factory in Washington, D. C.

Bibliographies of unclassified references to uranium deposits were prepared for each State, and leaflets are now being prepared which will contain information about uranium in states for which there are no published references. It is hoped that this material will further aid in answering questions from the public about uranium in any part of the United States. A total of about 700 replies to public letters of inquiry concerning uranium were dispatched in the period December 1, 1953 to June 1, 1954.

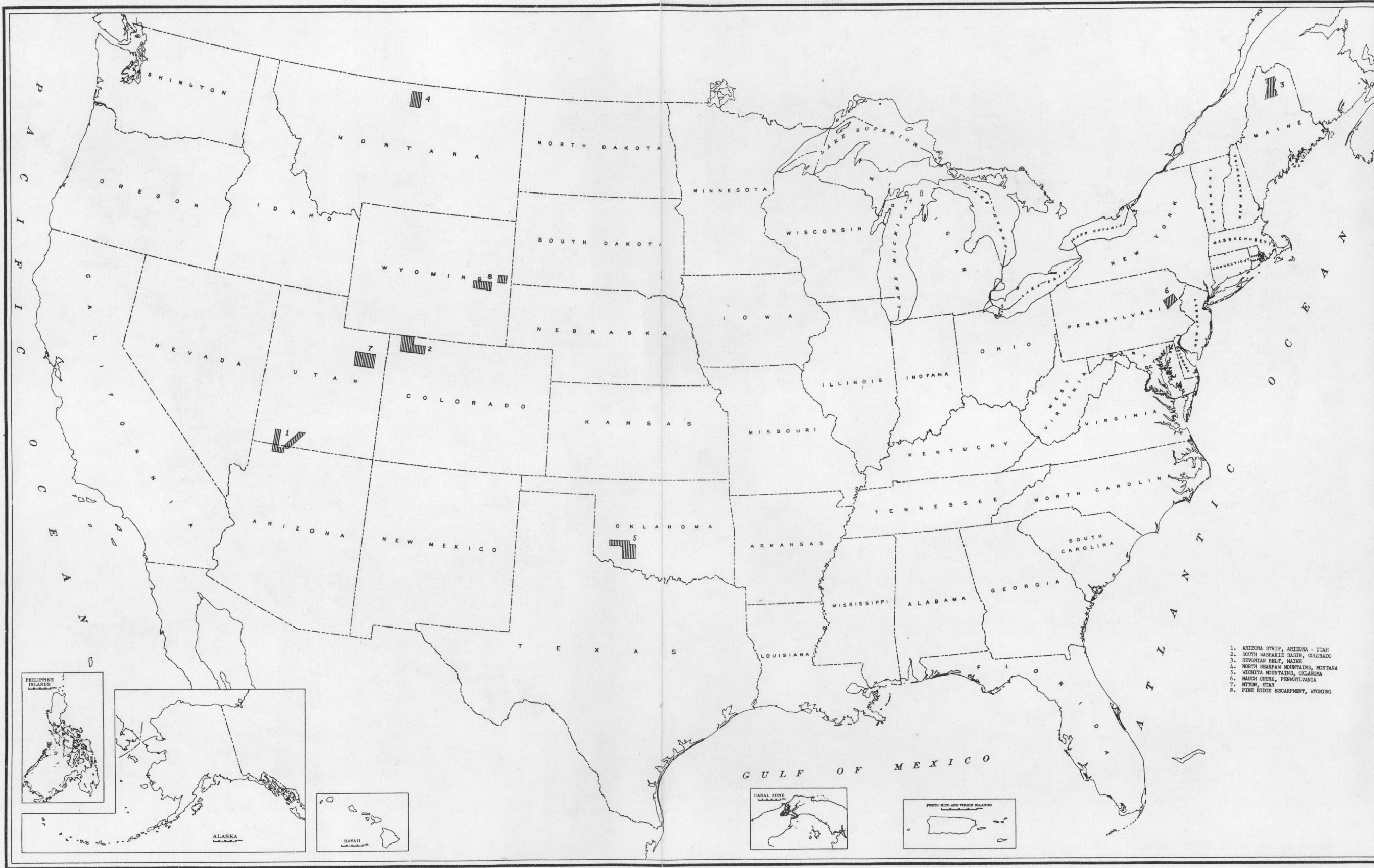

- 1. ARIZONA STRIP, ARIZONA - UTAH
- 2. SOUTH WASHATE BASIN, COLORADO
- 3. DEVONIAN BELT, MAINE
- 4. NORTH BEARPAW MOUNTAINS, MONTANA
- 5. WICHITA MOUNTAINS, OKLAHOMA
- 6. MAUCH CHERT, PENNSYLVANIA
- 7. MITTEN, UTAH
- 8. PINE RIDGE ESCARPMENT, WYOMING

Scale 1:625,000
 Approximately 80 miles to 1 inch
 0 50 100 150 200 Miles
 1953

Base compiled by U. S. Geological Survey
 Projection and shore line by the U. S. Coast and Geodetic Survey
 Altitude equal-area projection
 North American datum

FIG. 44--AIRBORNE RADIOACTIVITY SURVEYS SCHEDULED, JULY-DECEMBER 1954.

