

FILE COPY
NO. 3

AIRCRAFT CIRCULARS
NATIONAL ADVISORY COMMITTEE FOR AERONAUTICS

No. 178

THE AIRSPEED "COURIER" COMMERCIAL AIRPLANE (BRITISH)
A Low-Wing Cantilever Monoplane

Washington
May, 1933

NATIONAL ADVISORY COMMITTEE FOR AERONAUTICS

AIRCRAFT CIRCULAR NO. 178

THE AIRSPEED "COURIER" COMMERCIAL AIRPLANE (BRITISH)*

A Low-Wing Cantilever Monoplane

The first British airplane with a retractable landing gear is the Airspeed "Courier," a small and aerodynamically clean monoplane which has been designed and built by the Airspeed Ltd. (figs. 1, 2, 3, 4).

The first "Courier" completed will be used in an attempt to fly from England to Australia without an intermediate landing, and therefore the airplane differs in many minor features from the ultimate standard model. Arrangements have been made for refueling the "Courier" in the air, and the whole of these arrangements, including those which concern the design of tanks and equipment for the refueling airplanes, have been undertaken.

Basically the "Courier" is a very straightforward low-wing cantilever monoplane built of wood, with a 240 hp Armstrong-Siddeley Lynx engine. The most interesting feature of the airplane is, naturally, the landing gear, which retracts upward and backward into the wing, so that only the lower third of each wheel protrudes through the lower surface of the wing (figs. 1 and 4).

A very neat and simple form of retractable landing gear has been evolved, which is claimed by the makers to be only about 30 pounds heavier than a normal fixed landing gear.

This increase of 30 pounds does not represent the total weight of the retracting mechanism, but the difference between the weight of the mechanism and the saving in weight of such details as wheel "pants," strut fairings, etc., of a normal modern fixed landing gear.

Each unit of the divided landing gear consists of a side Vee, the front leg of which is a unit of an oleo shock absorber, and a bent axle. The oleo leg and the axle are hinged to the front spar, so that they may swing

*From The Aeroplane, March 22, 1933.

backward. The rear leg of the Vee, the top end of which is hinged to the lower flange of the rear spar, is jointed at a point about two thirds of its length from its attachment to the oleo leg. In the extended position it is locked thus by the joint and is held slightly past the straight by the hydraulic operating unit.

This operating unit consists of a telescopic strut, which is hinged at its upper end to the upper flange of the rear spar and at its lower end to the rear leg of the Vee just above the joint. Incorporated in this strut is a double-ended pump, the piston of which is moved up and down by exhausting oil from one side of it and pumping it in at the other.

To raise the landing gear the oil is exhausted from above the movable piston and is pumped in below so that the telescopic strut is shortened. This "breaks" the joint in the rear leg of the Vee and swings the longer portion of the rear leg round in a section of an arc which has its radius at the hinge point on the lower flange of the rear spar.

The lower ends of the front shock-absorber leg and the axle are thus pulled upward and backward by the shorter portion of the jointed rear leg, and finally come to rest in suitably shaped recesses in the underside of the wing.

The wheel itself is buried as far as it will go in the wing and fairings fore and aft streamline what portion of the wheel is left below the surface. Fairing strips mounted on the oleo leg and the axle close up the recesses when the landing gear is retracted.

The operating mechanism for the retracting as previously referred to, consists of a three-way cock and a hand pump. The three-way cock controls the direction of flow of oil, for raising and lowering, or locks the landing gear in either the up or down position, and the pump raises or lowers the wheels.

A tell-tale mechanism is incorporated in the installation. This consists of an auxiliary telescopic unit, which is attached to each of the hydraulic pumps and moves with it. Each of these auxiliary units has a sliding piston and a number of electrical contacts which, when in circuit, light up suitably colored lights on the pilot's

instrument board when the throttle is closed. When the landing gear is in the extended position a green light shows, and when it is in the raised position a red light shows. For any position between the maximum up and down positions an orange light shows.

The general arrangement of the landing gear and its mechanism is shown in figure 5.

Of the rest of the airplane everything is more or less straightforward. The wing structure is normal except that diagonal wooden girders are used for the internal bracing and produce a very strong and rigid wing panel. (See figs. 6 and 7.)

The equipment of the special airplane which is the subject of this description, differs considerably from what will be the standard arrangement. This airplane will have accommodation for a crew of two, seated side by side, with dual controls. The special tanks will hold a maximum of 275 gallons of gasoline and 17 gallons of oil, enough for 25 to 26 hours' flying. With two people, equipment and full load of gasoline, the "Courier" will weigh 5,050 pounds.

Actually the "Courier" is not supposed to take off with anything like a full load, so that no special airport with runway will be necessary. The full quantity of gasoline will be taken on from a refueling airplane when the "Courier" is in the air.

The arrangement of the gasoline tanks is interesting. One tank of 62 gallons is between the wing spars below the cabin, and linked with this tank are two other tanks, each of 29 gallons, between the spars but outside the fuselage. These three tanks form one unit. Two more extension tanks, each of 61 gallons capacity, are carried farther out in the wings, and these are connected to the middle tank by pipes provided with shut-off taps. An additional 21-gallon tank is carried in the fuselage, and a 10-gallon gravity tank, fed by engine pump, or auxiliary hand pump, from the main tank, is mounted in the usual position behind the fireproof bulkhead.

The normal procedure is to use the gasoline from the main tank. When this is 75 percent empty the taps from the extension tanks are opened and the gasoline from these tanks is emptied into the main tank, after which the taps are shut again.

The refueling inlet is in the roof of the cabin and the inlet pipe leads straight to the main tank. Fuel is led to the extension tanks by judicious lateral movement of the airplane, and when each outer tank is filled the tap is closed until the contents of these tanks are again wanted.

A jettison valve is fitted to the main tank and an evacuation pump is provided to speed up the jettisoning of the gasoline. When the tanks are empty they will provide flotation for the airplane should it be forced to alight on the sea.

The empty weight of the special "Courier" is 2,300 pounds, as compared with 2,100 pounds for the standard model. Fully loaded, the airplane will have a cruising speed of 120 miles per hour as opposed to 130 to 135 miles per hour of the standard "Courier."

The following specification describes in a concise way, the standard "Courier," which has been designed as an economical high-speed passenger or freight-carrying monoplane. The cabin is spacious enough to accommodate four passengers and a generous amount of luggage or six people, including pilot, and no luggage.

SPECIFICATION

Type.— Single-engine freight or passenger carrying monoplane.

Wings.— Low-wing cantilever monoplane. Center section (10 feet 3 inch span) built integral with fuselage. Outer sections, of tapering chord and thickness, attached to center section by four bolts and locking nuts, one to each spar joint (fig. 8). Bolts pass through tapered high-tensile steel plugs at each end to take shear. Wing structure consists of two box spars of spruce and birch three-ply. (The birch ply consists of three laminations, the middle of which is twice the thickness of the outer, and all the grains are set at 45 degrees.) Former ribs are of normal girder type. Special system of interspar bracing consists of built-up diagonal struts. Leading edge is of veneer bound with fabric strips midway between each nose rib (fig. 9). Fabric covering. Frise type ailerons. (fig. 10).

Fuselage.- In three sections. Front section, from engine plate to instrument board, of welded steel tube. Middle and rear sections have spruce longerons and bulkheads, all covered with plywood.

Tail unit.- Monoplane type. Wooden framework with fabric covering (fig. 11). Cantilever stabilizer and fin. Balanced rudder is hinged to fin only, with hinge line inclined forward. Adjustable stabilizer with screw jack under rear spar.

Landing gear.- Retractable type. (Described hereinbefore) Dunlop wheels and hydraulic wheel brakes. Dunlop tail wheel.

Power plant.- One 240 hp. Armstrong-Siddeley Lynx IV.C air-cooled radial engine on welded steel-tube mounting. Townend ring. Two standard alternative fuel tank arrangements may be supplied. Either one or two 28-gallon tanks in between spars of center section, and one 10-gallon gravity tank in front of instrument board. Gasoline is pumped by duplicated engine-driven pumps from main tank, or tanks, to gravity tank, thence by gravity to engine. Electric A.S. starter or hand inertia starter is used.

Accommodation.- Enclosed cabin, for crew of two and four or five passengers. Two front seats have dual controls. Control columns detachable, so that either seat may be used by the pilot and the other by a passenger, when five are carried. Arrangement of remaining seats depends on desired arrangement of cabin. Ample windows in top of sides and roof. Sliding panels in windshield and side windows. Entrance to cabin through large door at back on port side. Emergency exit in roof. Dimensions of cabin: 8 feet long by 3 feet 8 inches wide by 5 feet 3 inches high (2.4 by 1.1 by 1.6 meters).

Controls.- Normal control columns operate elevators and ailerons by straight lengths of cable and chains passing over ball-bearing sprockets. Hanging rudder pedals are suspended from two cross tubes interconnected by sprockets, two right-footed pedals on one tube and the two left-footed pedals on other (fig. 12). Each tube has at one end a lever which connects direct to appropriate side of rudder by cable. Wheel-brake lever, stabilizer adjustment hand wheel and wheel-raising mechanism are accessible to both front seats. Differential brake controls are used for taxiing, operated by rudder pedals.

Dimensions:

Span	14.3 m	47 ft.
Length	8.7 "	28 ft. 6 in.
Height	2.6 "	8 ft. 9 in.
Total wing area	23.2 m ²	250 sq.ft.

Weights:

Weight empty	953 kg	2,100 lb.
Disposable load	613 "	1,350 "

Performance (estimated):

Maximum speed at ground level	240 km/h	150 mi./hr.
Cruising speed at 305 m (1,000 ft.)	207 "	130 "
Stalling speed	88 "	55 "
Range (38 gallons of gasoline)	720 km	450 miles
Range (66 gallons of gasoline)	1,230 "	780 "

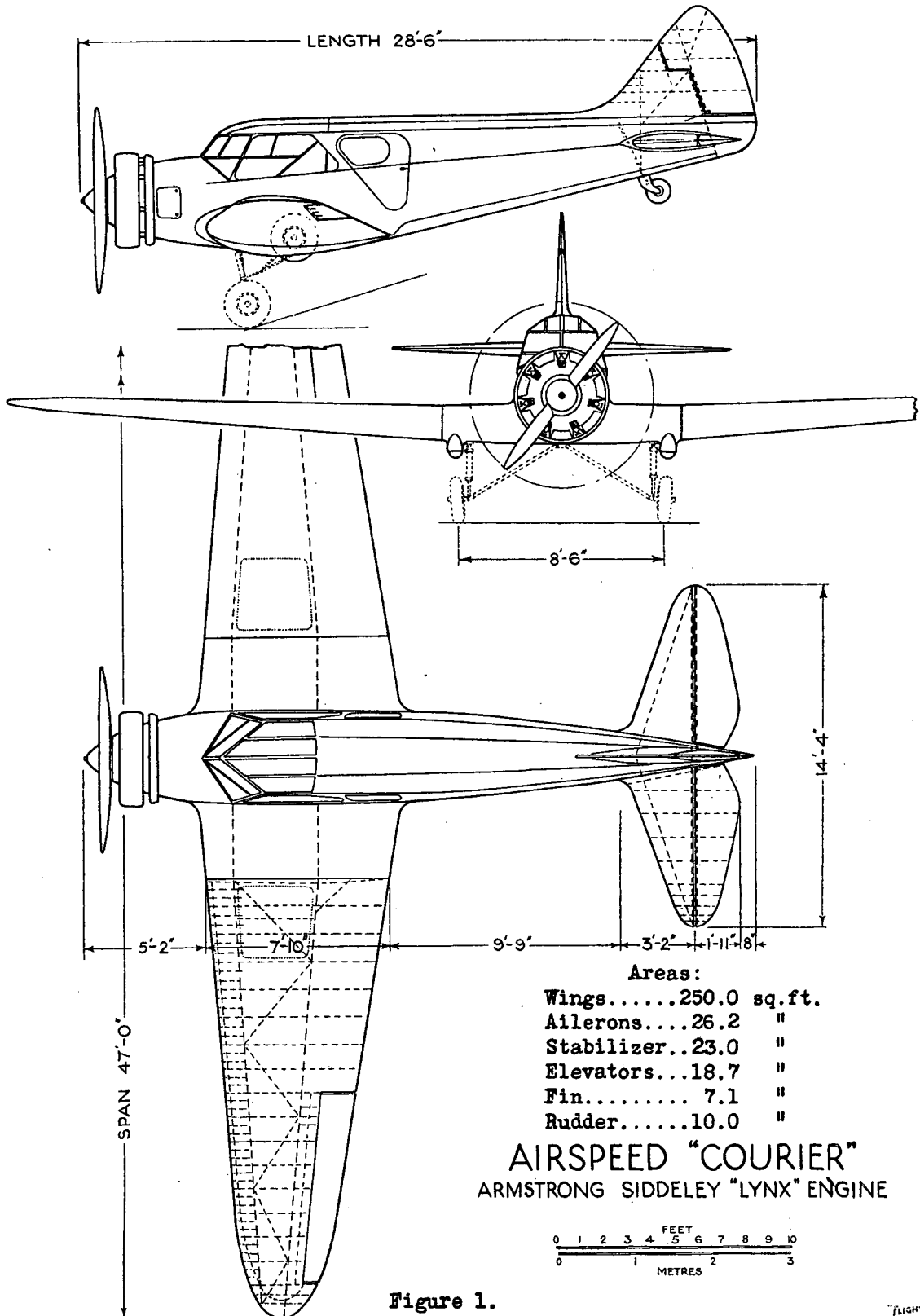
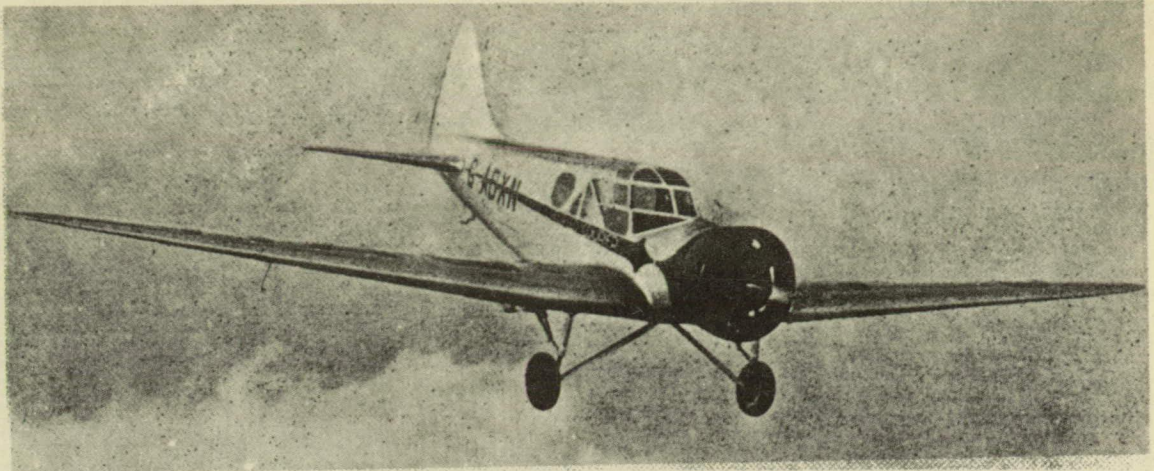
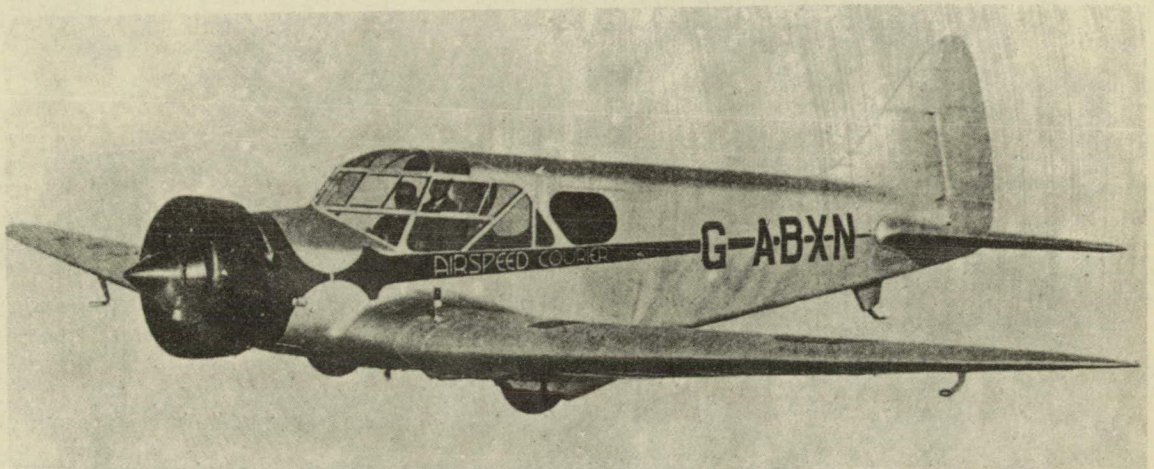

Figure 1.



"Aeroplane"

Landing gear in position for landing



"Aeroplane"

Landing gear in flying position



"Aeroplane"

Figures 2,3,4-Views of the Airspeed Courier airplane,

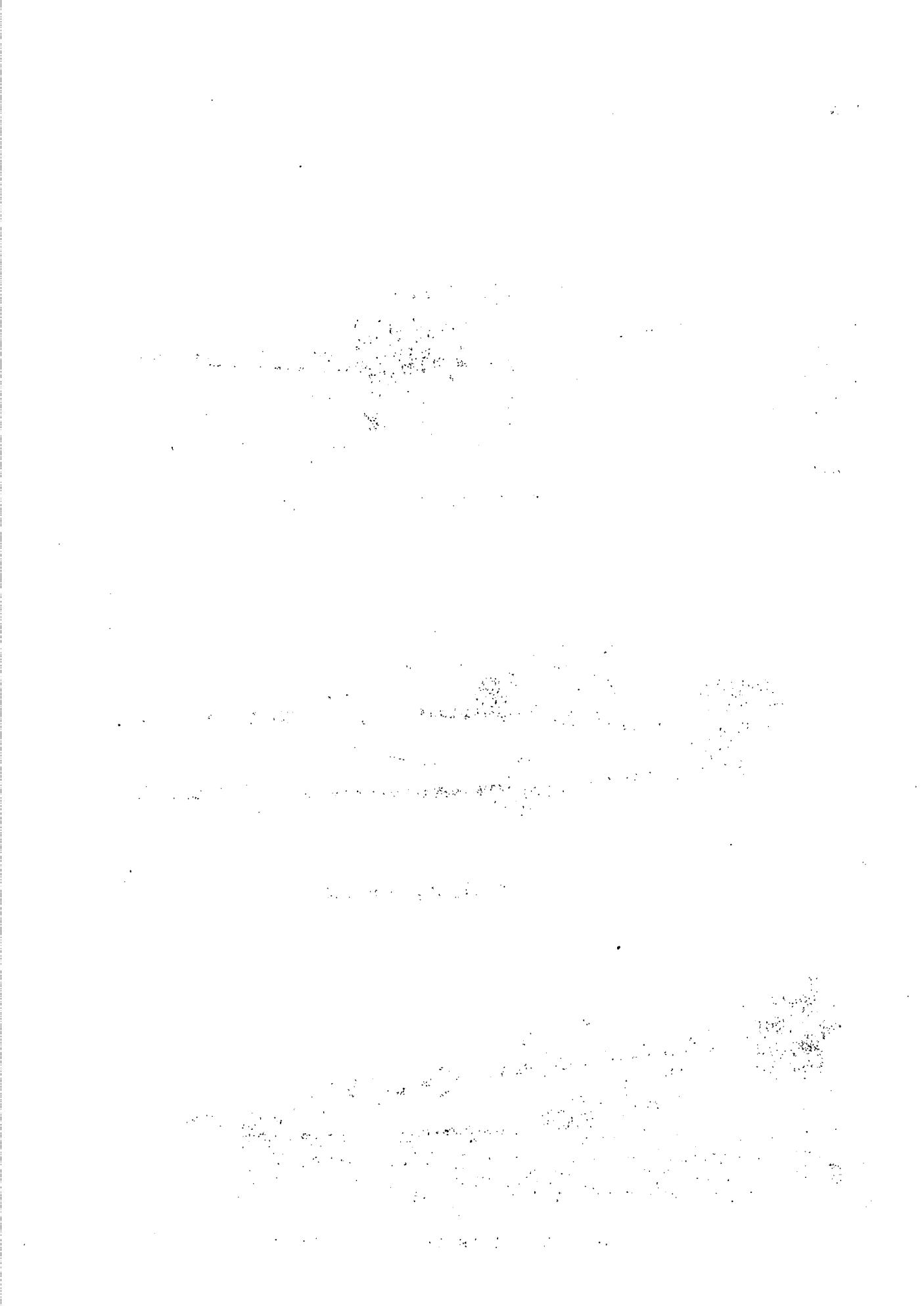

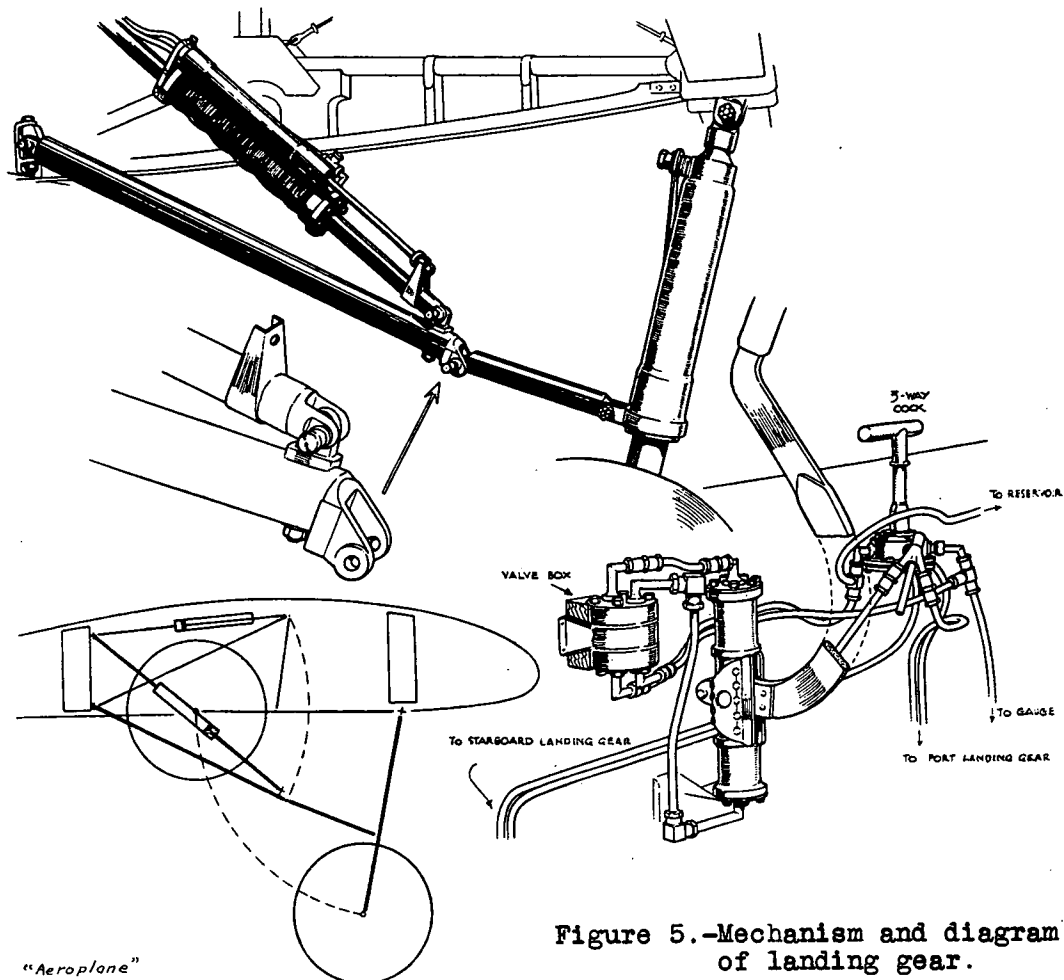

Figure 5.-Mechanism and diagram of landing gear.

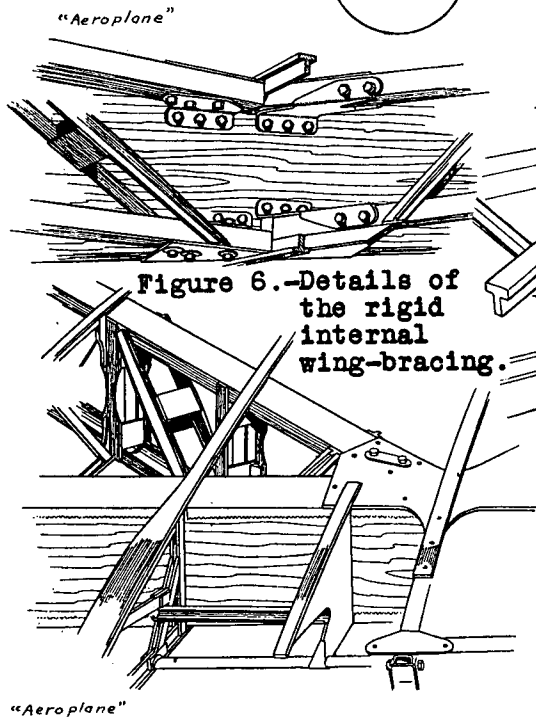

Figure 6.-Details of the rigid internal wing-bracing.

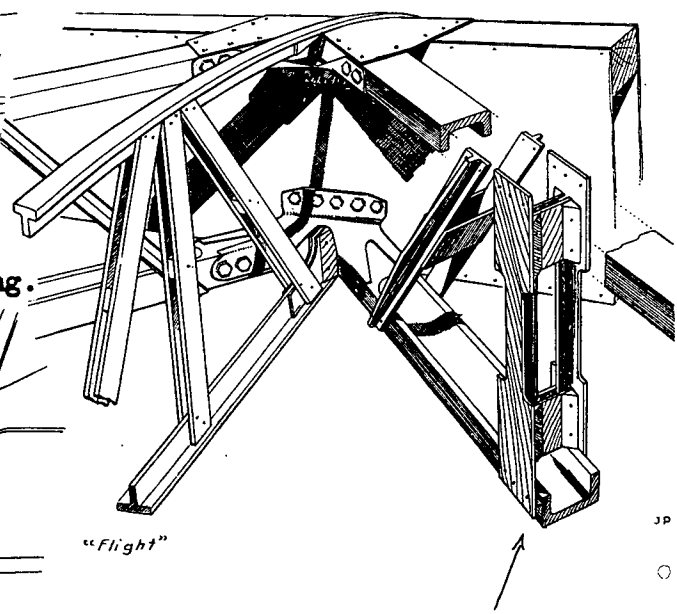

Figure 7.-Drag bracing.

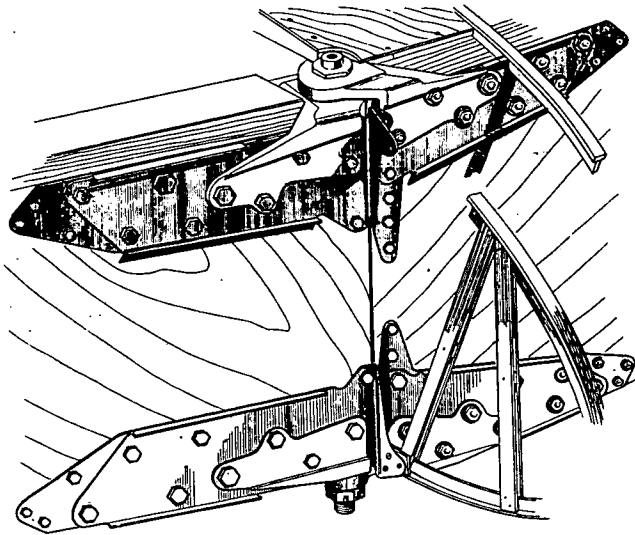

Figure 8.-Wing joint of the Airspeed Courier airplane.
"Flight"

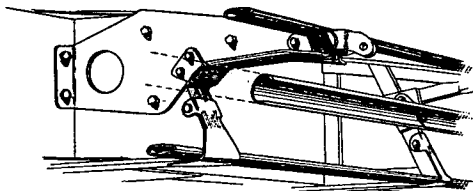
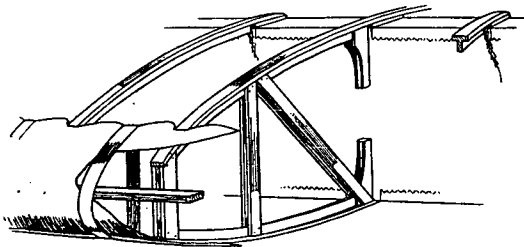

Figure 9.-Details of the leading and trailing edges.
"Aeroplane"

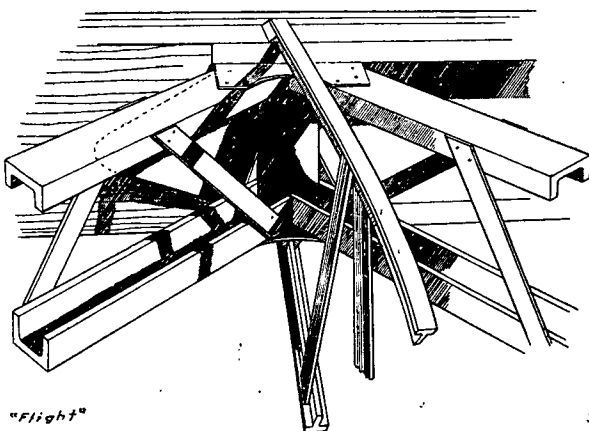

Figure 11.-Details of stabilizer.
"Flight"

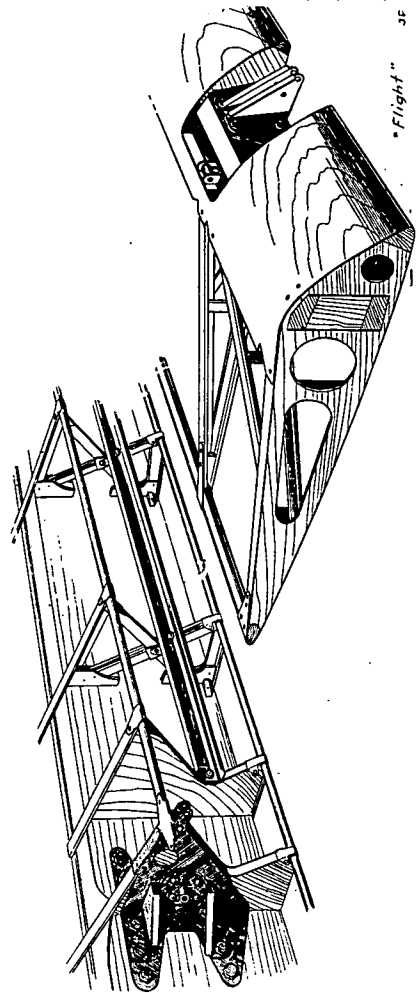

Figure 10.-Frise type ailerons. Hinge support is shown on left.
"Flight"

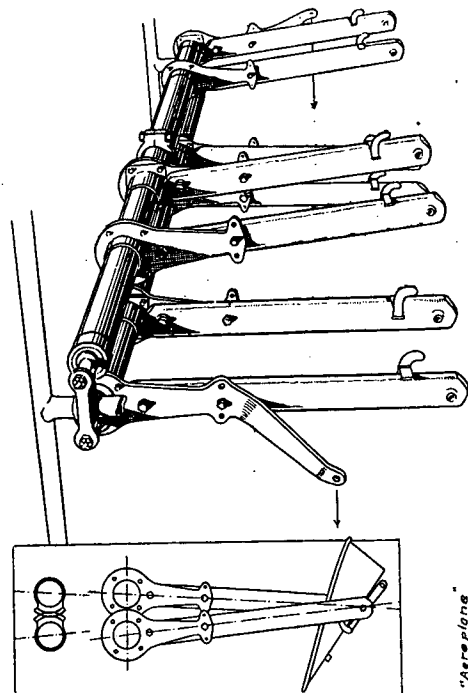

Figure 12.-Rudder - pedal assembly.
"Aeroplane"