



DRAFT DELIBERATIVE DOCUMENT - FOR DISCUSSION PURPOSES ONLY
DO NOT RELEASE UNDER FOIA

dcn: 9867



Site Familiarization Briefing to COL Weaver



Ft Carson – The Mountain Post

6 Apr 04



Agenda

- . **Mission/Vision**
- . **Background/Demographics**
- . **Organizations**
- . **Force Modernization**
- . **Power Projection/Jointness**
- . **Range/Simulations Initiatives**
- . **Multi-Component Initiatives/Activities**
- . **Environmental Stewardship and Sustainability**
- . **Partnerships**
- . **Health Services**
- . **Well-being Initiatives**
- . **Infrastructure Improvements**
- . **Excess Capacity**
- . **Summary**



Our Mission

“7th Infantry Division and Ft Carson trains, mobilizes, deploys, and sustains combat-ready forces. We ensure the well-being and protection of the Mountain Post Team, while operating a responsive, efficient and sustainable installation, Post Mobilization Maneuver Training Center and power projection platform.”



Our Vision

“As a Premier Army Flagship Installation we remain well postured to train and equip soldiers, develop future leaders, grow Army families and remain a committed community partner. As an Integrated Division, the 7th Infantry Division will lead the Army as an AC/RC integrator, a first class Power Projection Platform (air and rail) and Post Mobilization Maneuver Training Center by providing combat-ready forces for the 21st Century Combatant Commander and Joint Team.”



Ft Carson, CO

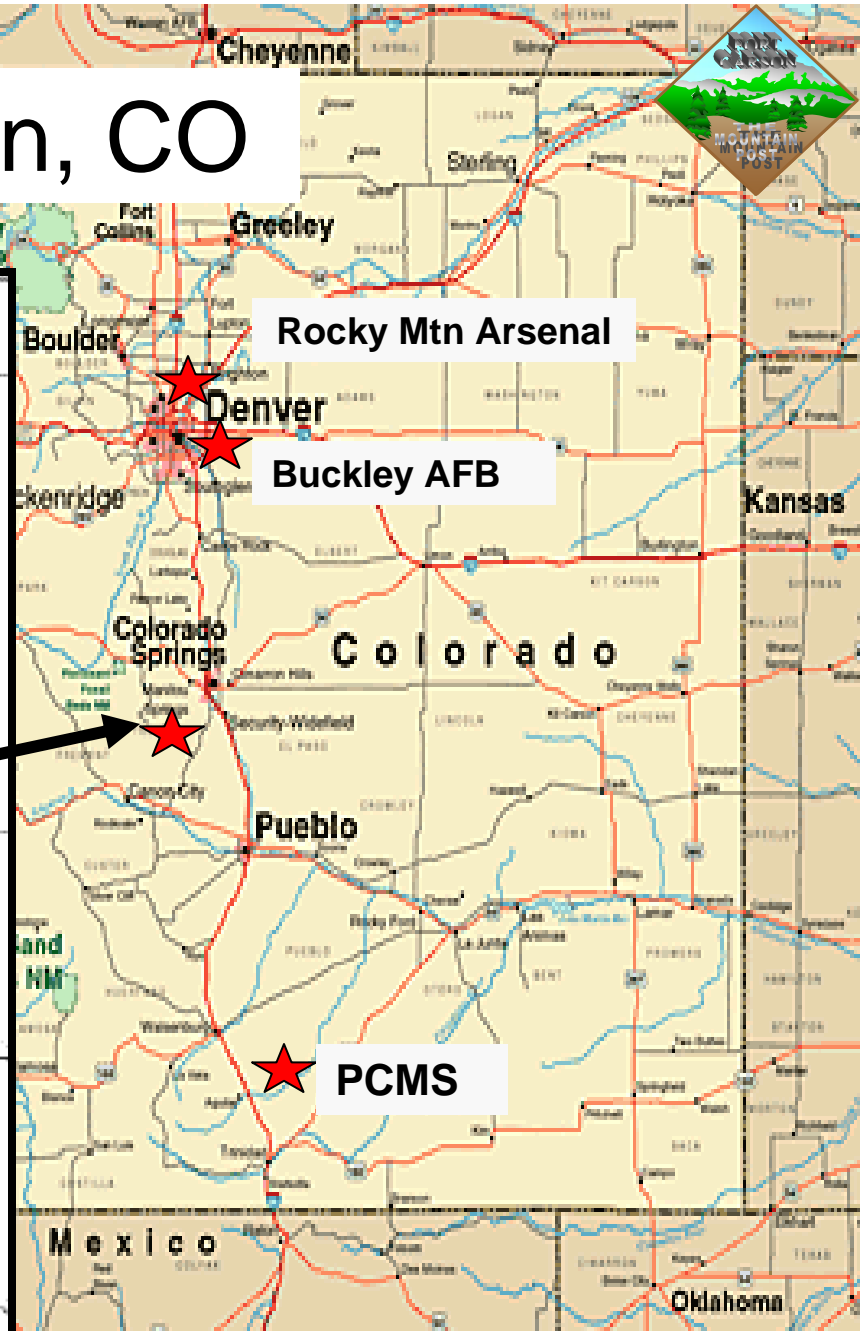
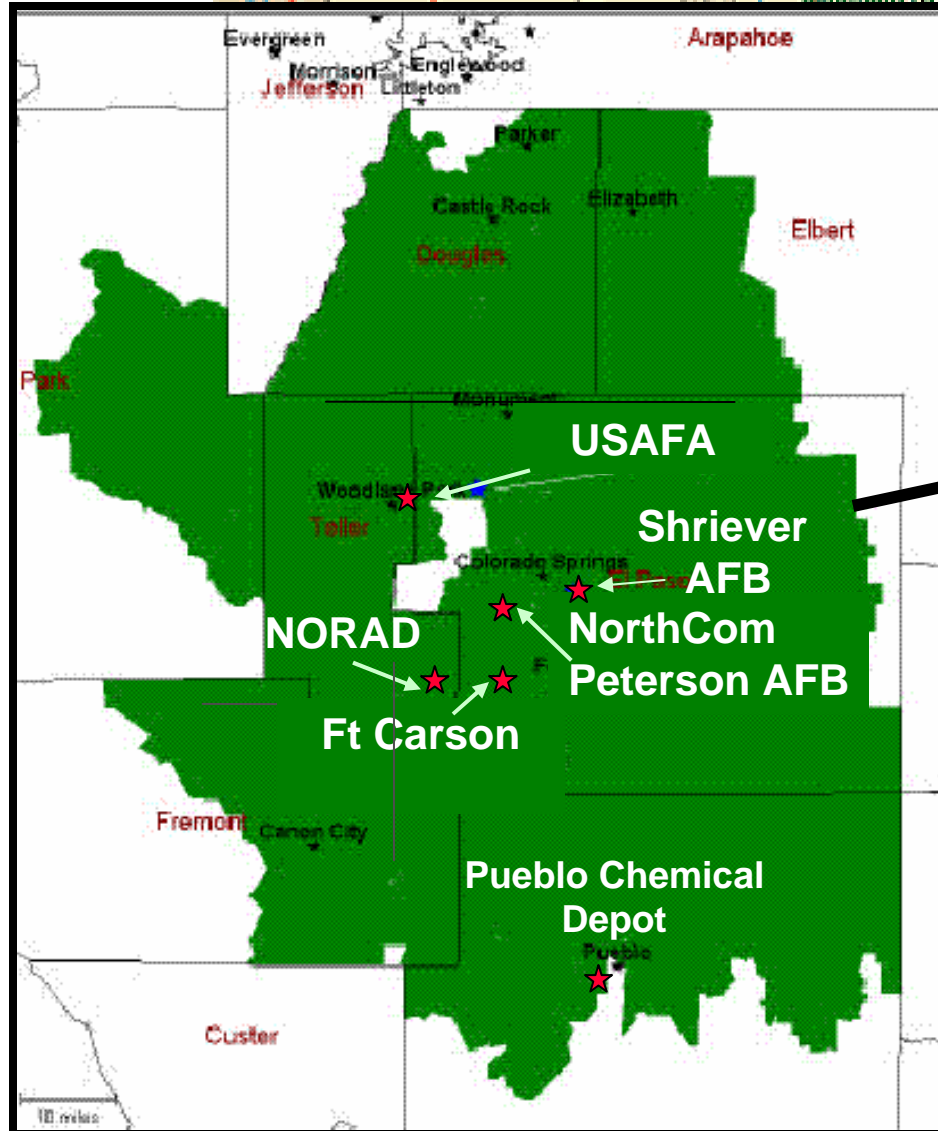



Background/Demographics

Ft Carson The Mountain Post



4th DIV
'70-'95

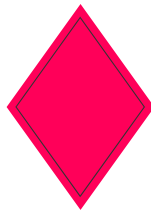

5th DIV
'62-'70



8th DIV
'54-'56



10th DIV
'45



71st DIV
'43-'44



9th DIV
'56-'62



31st DIV
'54



104th DIV
'44



89th DIV
'42-'44

World War II

Korean Conflict

Vietnam Conflict

Desert Storm

SFOR (Bosnia)

KFOR (Kosovo)

OEF (Afghanistan)

OIF (Iraq)

7th Infantry Division (Light)
'99- Present





Ft Carson Population

Over:

16,260	Active Duty Military
25,860	Family Members (6,800+ living on-post)
1,780	DA Civilian employees
940	NAF/AAFES PX employees
1,460	Contractors
23,470	Retirees (Colorado Springs/Pueblo area)
33,370	Retiree Family Members

2nd Largest Military Retiree Community in the U.S.

...a Population of over 103K



Ft Carson Economic Impact

Military Payroll	\$660.2 million
DA Civilian Payroll	\$108.1 million
Rent, lease & utilities	\$12.9 million
Procurement	\$175.1 million
TRICARE Payments	\$41.3 million
College Tuition & Grants	\$1.7 million

Annual Impact of \$999 million

Funded MCA Projects FY03-06	\$115.75 million
Funded NAF Projects FY04	\$4.7 million

Impact of \$120 million

...an impact of over \$1.1 billion



Major Community Facilities

- 2,363 Sets of Family Quarters
 - 840 new homes built
 - 500 homes to be built in next 3 years
 - Renovating 1843 existing homes
- 4 Schools: 3 Elementary; 1 Middle [2,598 student capacity]
- 116 Bed Hospital & 4 Dental Clinics
- 4 Gyms/Fitness Centers / 1 Wellness Center
- 3 Family Service Centers
- 5 Chapels
- 4 Child Care Centers
- 1 Youth Services Facility
- 63 MWR Facilities (Indoor/Outdoor)



Some of Our Recent Recognitions

- 2004 Picker Award – MEDDAC Award for Customer Satisfaction
- 2003 Secretary of the Army Energy and Water Management Award
- 2003 Army Fire Department of the Year
- 2003 Presidential Award for Leadership in Federal Energy Mgmt
- 2003 Mounted Cavalry Association, National Champions
- 2002 Best Recreation Delivery System in Army
- 2002 Numerous Connelly Awards (Dining Facility) at FORSCOM level
- 2002 Best Army Community Service (ACS) Center in Army (large post)
- 2002 ACS Family Advocacy Program Center of Excellence
- 2001 DA Community Relations Award
- 2001 Winner of DoD Thomas Jefferson Journalism Award
- 2001 Best Alcohol & Drug Control Office in Army
- 2001 Carroll Awards – Golf Course and Elkhorn Conference Center





Organizations



Ft Carson Major Subordinate Commands

OIF I

18 M109A6
HOWITZERS

123 M1
TANKS

24 OH-58D
HELICOPTERS



**3d Armored Cavalry
Regiment
5,568 Soldiers**

125 M3
BRADLEYS
30 UH-60L
HELICOPTERS
14 AH-64
HELICOPTERS

OIF I

18 M109A6
HOWITZERS



**3d Brigade, 4th Infantry Division
(Mechanized)
4,421 Soldiers**

45 M1
TANKS
92 M2
BRADLEYS

OIF I & II

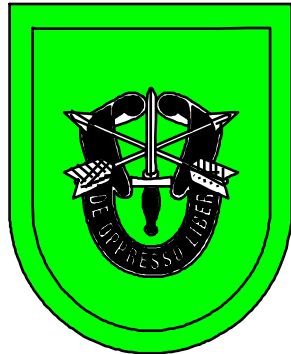

**10th Special Forces Group (Airborne)
1,014 Soldiers**

OIF I & II



**43d Area Support Group
2,703 Soldiers**



Ft Carson Active, Reserve and Joint Forces



13th Air Support Operations Squadron
73 Airmen



Army World Class Athlete Program
97 Soldiers
1 Civilian



Ft Carson USAG/
HHC, 7ID
320 Soldiers
748 Civilians



11th Brigade, West
119 Soldiers
27 Civilians
38 Contractors



Naval Reserve Center
220 Sailors



48th MP Det
16 Soldiers
2 Civilians



MEDDAC
416 Soldiers
773 Civilians



DENTAC
61 Soldiers
74 Civilians



VETCOM
54 Soldiers
3 Civilians
29 NAF Personnel



764th EOD
52nd Ordnance Group
11 Soldiers



5025th Garrison Support Unit
1st MOB Brigade
312 Soldiers (RC)
1433 Soldiers (CSB)



2-91st Tng Spt Bde
818 Soldiers (AC/RC)
12 Civilians



Colorado ARNG
389 Soldiers
42 Civilians



***DRAFT DELIBERATIVE DOCUMENT - FOR DISCUSSION PURPOSES ONLY
DO NOT RELEASE UNDER FOIA***





Force Modernization



DRAFT DELIBERATIVE DOCUMENT - FOR DISCUSSION PURPOSES ONLY
DO NOT RELEASE UNDER FOIA



Our Active Component Units "Preparing for the Future"

Force Modernization



Apache Longbow AH-64
Aug-Dec 04



Hercules M88A2
Jun-Oct 04



FMTV
Mar-Jul 04



TUAV
Aug-Nov 04



Digital TOC
FY04



FRS-H
FY'04

+ 8 additional new equipment fieldings between now and May 2005

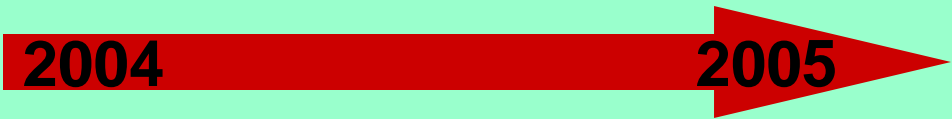

3BCT/4ID May-Nov 05
3ACR FY06/07

- M1A2 Abrams SEP Tanks
- M2A3 Bradley Fighting Vehicles
- Fire Support Systems
- Tactical Unmanned Aerial Vehicles
- ABCS Computer Systems and Networks
- Enhanced Communications Systems
- Maintenance Systems
- Digitized Tactical Operations Centers

Unit Set Fielding (USF)

Capabilities based Transition
Analog -----> Digital

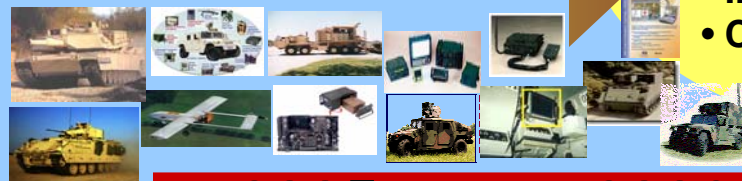

- Synchronized approach to:
- Digital & enhanced C4ISR
 - Battlefield Situational Awareness
 - Increased lethality
 - Combat Service Support Reorganization



Endstate: Modernized, Cohesive, Competent, Capable, Ready



***DRAFT DELIBERATIVE DOCUMENT - FOR DISCUSSION PURPOSES ONLY
DO NOT RELEASE UNDER FOIA***





Power Projection/Jointness



***DRAFT DELIBERATIVE DOCUMENT - FOR DISCUSSION PURPOSES ONLY
DO NOT RELEASE UNDER FOIA***





DRAFT DELIBERATIVE DOCUMENT - FOR DISCUSSION PURPOSES ONLY
DO NOT RELEASE UNDER FOIA



Ft Carson

“A Power Projection Platform”

Since 11 Sep 01



403 Reserve Units (21,436 Soldiers) from 40 States
98% of our Active Force (13,410 Soldiers)

- 3d Armored Cavalry Regiment: 5,700 Soldiers
- 3d Brigade, 4th Infantry Division (Mechanized): 4,132 Soldiers
- 43d Area Support Group: 2,578 Soldiers
- 10th Special Forces Group (A): 1,000 Soldiers





Power Projection Capabilities/Initiatives

Rail Facility

- State-of-the Art
- 180 cars/day capability
- 10 spurs
- 3 locomotives

Vehicle Marshaling Area

- MCA 04
- \$2M
- For both wheeled and tracked vehicles

SRP Center

- MCA 09
- \$7.5M; 40,000sf facility
- Replaces SRP site in old hospital area

Arrival/Departure Air Control Group (A/DACG) Facility

- FY06/07 MCA
- Increase wide-body aircraft loading capacity from 3 to 6
- Indoor pallet building and weighing area
- Indoor maintenance facility
- Indoor MHE storage
- Equipment storage facility for IRC
- Passenger processing/holding area for 1,200 Soldiers
- C² facilities (S1-S4)



Peterson AFB and Colorado Springs Airport

Phase 1: (FY06 \$30M) partial North/South lighted taxiway; underground piping for fuel; aprons and ramps

Phase 2: (FY07 \$22M) Operations Building (support deployment activities); maintenance building and indoor parking for DRB; indoor parking for MHE

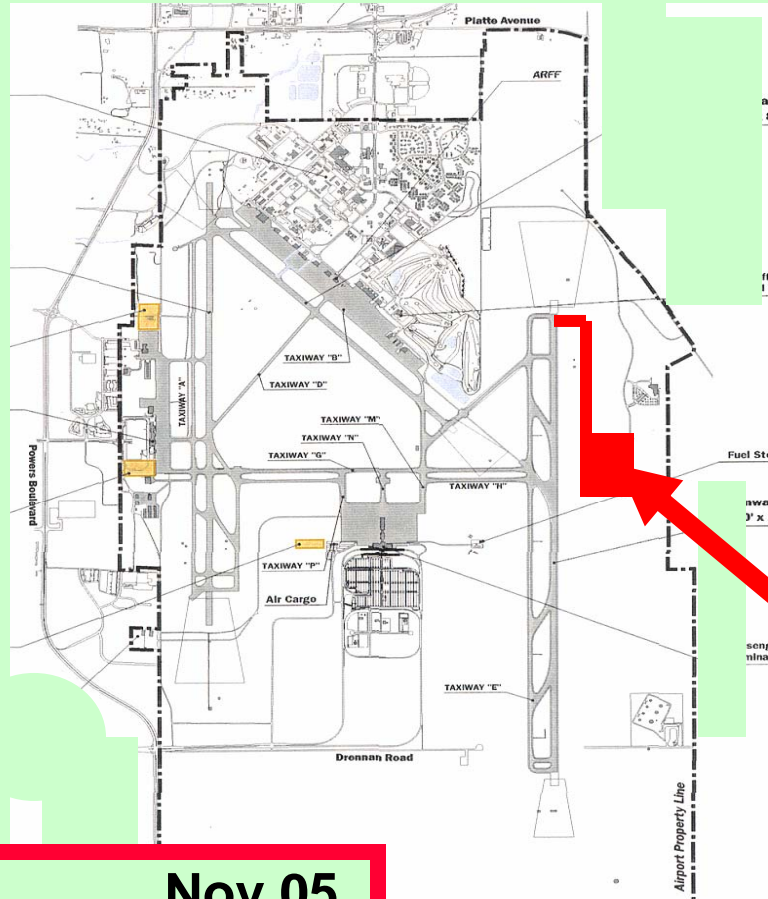

A/DACG Site (36 Acres)

Award Contract

Nov 05

Phase 2 Complete

Aug 08



Planned Transportation Improvements

Gate 20 & State Highway 16

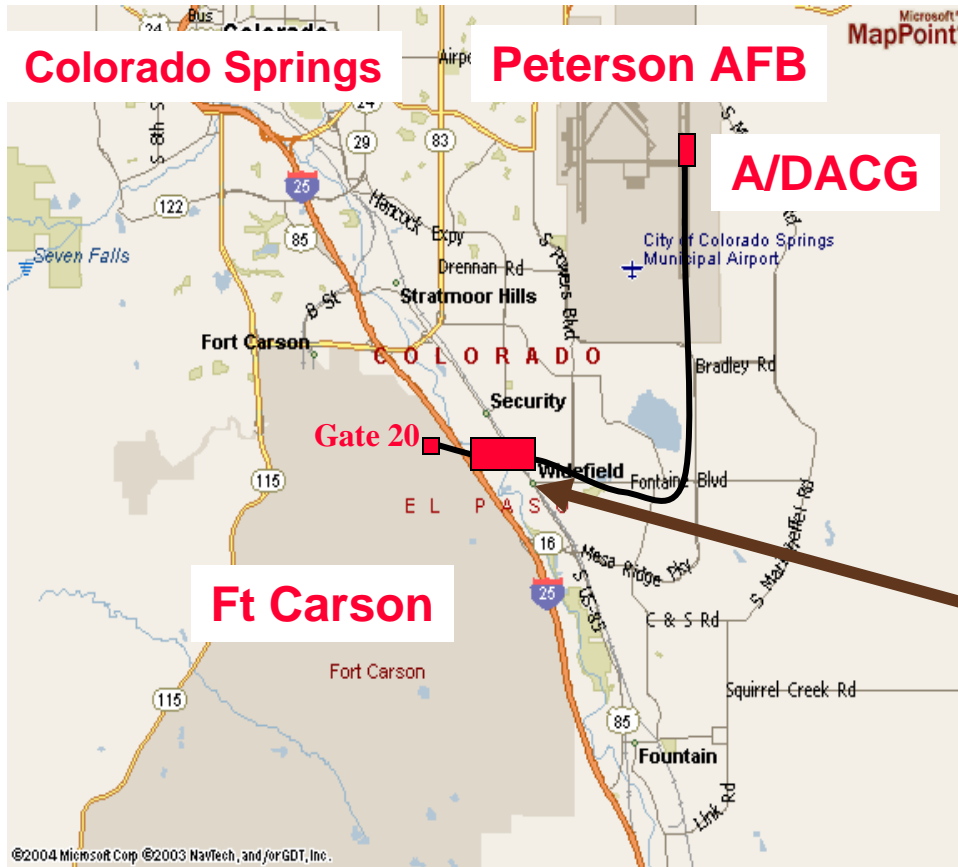

State approved project awaiting funding – DAR funds to supplement upgrades

Ft Carson

- 4 Lanes at Gate 20
- 2 inbound / 2 outbound to connect to SH 16

State/County/City

- Widening SH 16
- Widening Bridge and access road to bridge/I-25

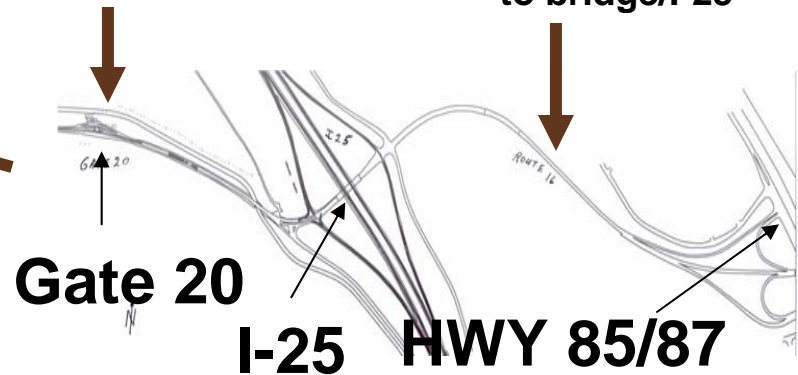

Enhances rapid tactical deployment of equipment and personnel as part of Ft Carson's Power Projection role



Ft Carson & Piñon Canyon Maneuver Site (PCMS)

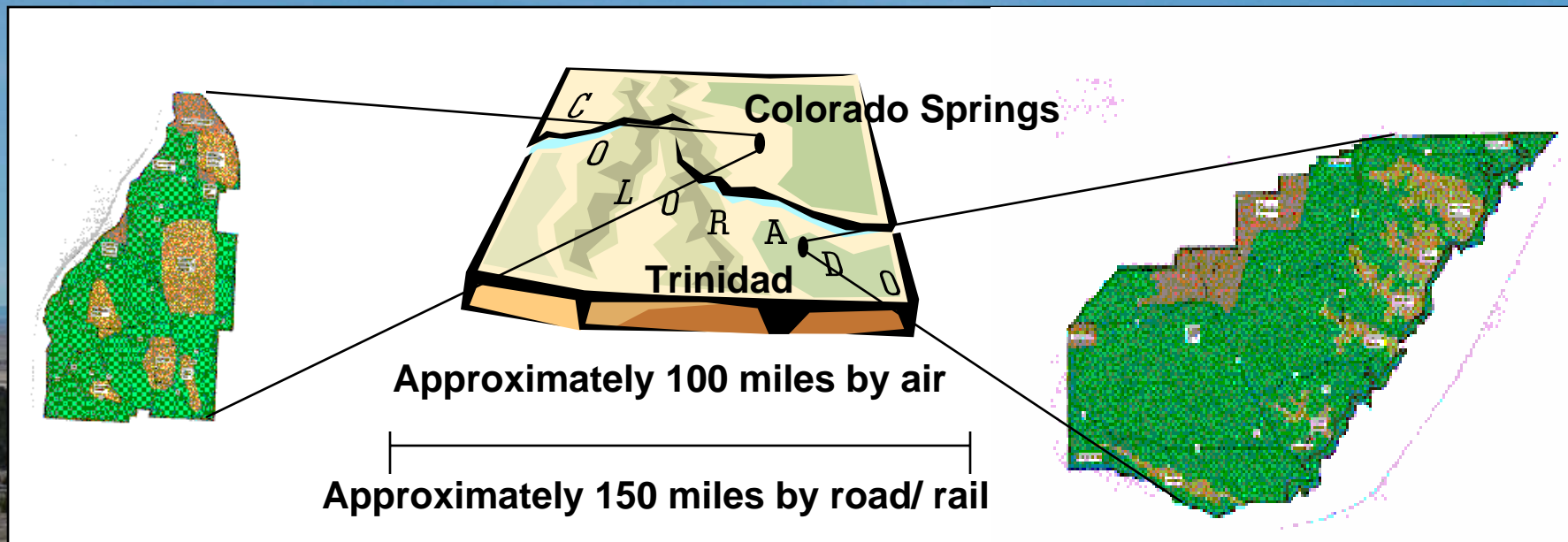

Ft Carson
137,403 Acres
“Current Forces”

Piñon Canyon
235,368 Acres
“Future Forces”



Joint Aerial Gunnery/Bombing Range & Large Impact Area



Major Unit Utilization

- Weapons School (Nellis AFB)
- 24th Special Tactics Squadron (AC-130)
- A/7-158th U.S. Army Reserve (CH-47)
- 27th Fighter Wing (F-16, Cannon AFB)
- 160th Special Operations Aviation Regiment
- 10th Special Forces Group
- 75th Army Rangers

1454 Total Sorties in FY02/03
4362 Various Aircraft
Over 21 Units

Major Unit Utilization

- 13th Air Support Operations Squadron
- 140th Air Wing (F-16 CO ARNG)
- 731st Airlift Squadron (C-130 PAFB, CO)
- 4th Squadron, 3d Armored Cav Regiment
- 150th Fighter Wing (F-16 NM ARNG)
- 4th Fighter Wing (F-15E)
- 5th Special Forces Group

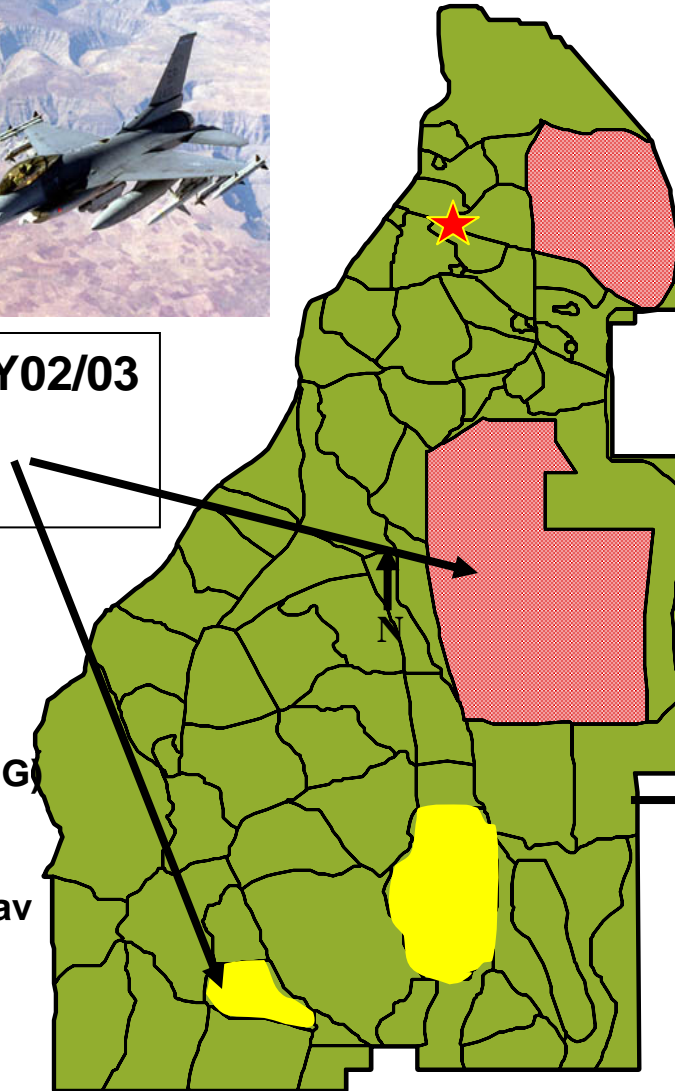



DRAFT DELIBERATIVE DOCUMENT - FOR DISCUSSION PURPOSES ONLY
DO NOT RELEASE UNDER FOIA



Piñon Canyon Maneuver Site Current Statistics

- 30 training areas totaling 235,368 acres
- 606.4 acre Cantonment Area
- 148,534 acre maneuver area (supports brigade-level maneuver)
- 53,105.2 acres for dismounted training
- C130 Assault Landing Strip



***DRAFT DELIBERATIVE DOCUMENT - FOR DISCUSSION PURPOSES ONLY
DO NOT RELEASE UNDER FOIA***





PCMS Cantonment Area

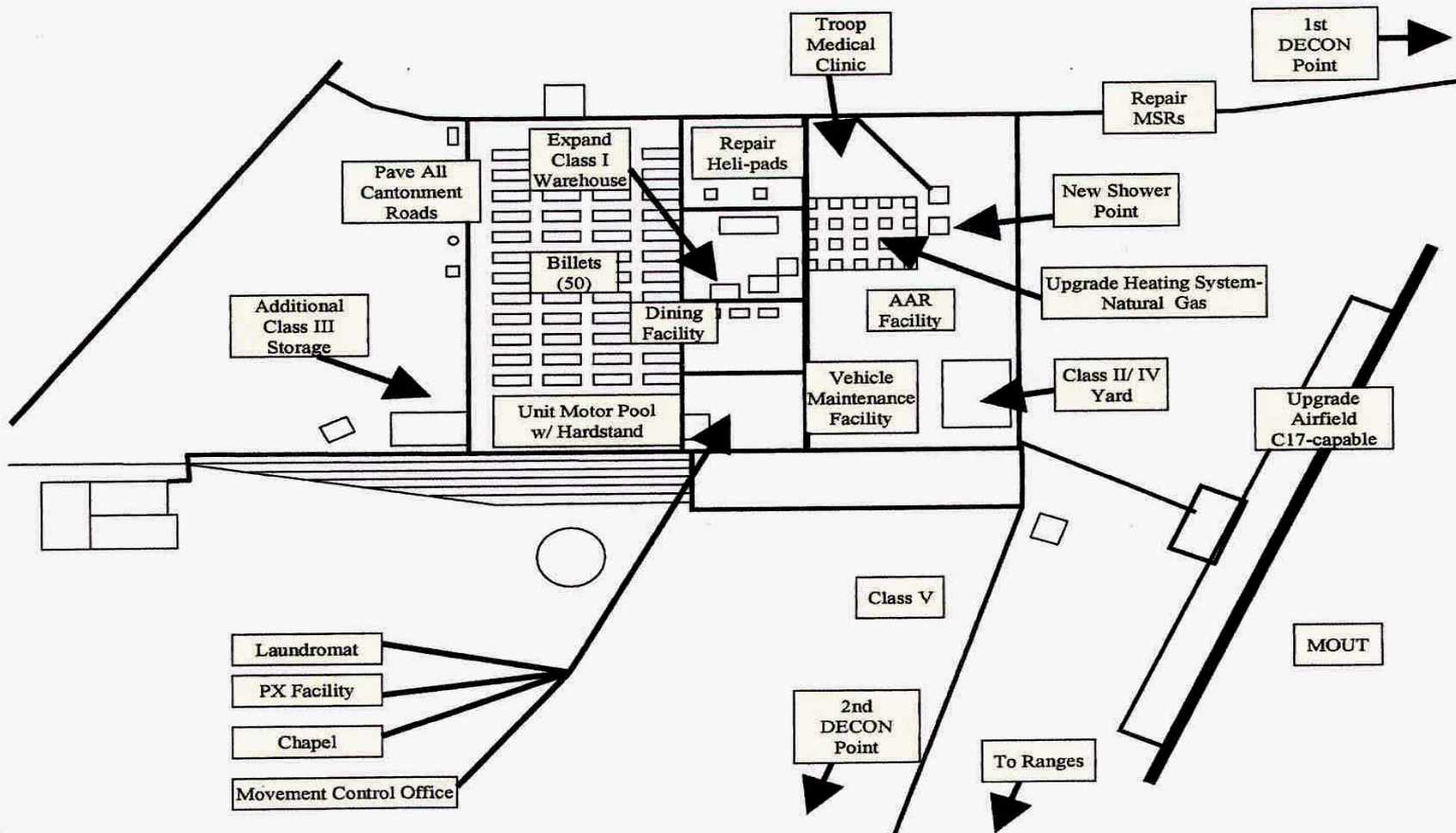



Piñon Canyon Joint Training Area



Proposed Total Acreage: 2,635,368

- JOINT TRAINING AREA**
- DA/G8 working to acquire additional land
 - Land Acquisition Cost: Approximately \$200 per acre of land – Extremely Affordable
 - Would become 4 Times larger than NTC with an additional 2 million acres available in Southeastern Colorado
 - 32 Bldg Digital Urban Warfare site: FY07
 - M1 Tank/M2 Bradley proficiency course: FY08
 - Mobile After Action Review Facilities
 - Combined Arms Live Fire Capability with all non-dud producing ordnance
 - Assault Landing Strip (C-17 capable)
 - Virtual Terrain Database

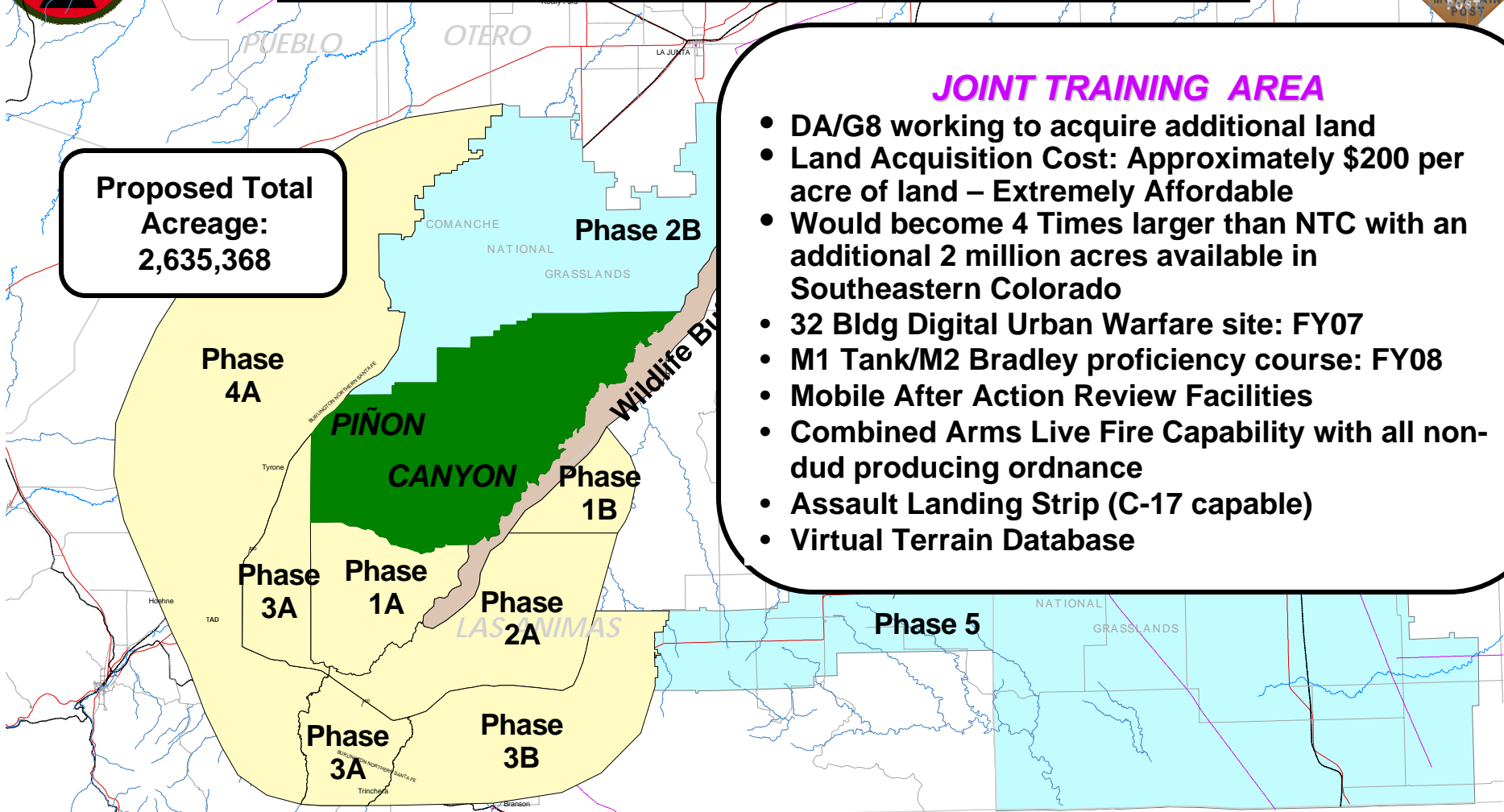

KEY:

- Current Piñon Canyon Boundary (Acreage: 235,368)
- Proposed Phased Land Acquisitions (Acreage: 2.4 million)
- Commanche National Grasslands



Range/Simulations Initiatives



Ft Carson Today Training Areas and Ranges

Small Arms Ranges:

- 9mm and .45 cal Combat Pistol
- M16A2/M4 (5.56mm)
- M240B/ M60 Machine Gun (7.62mm)
- M249 Machine Gun (5.56mm)
- .50 cal M2 Machine Gun (Crew Served)

Grenade Ranges

Mortar Ranges

Anti-tank Ranges

Mechanized Infantry and Armor
Maneuver Live Fire Ranges

Maximum Charge/Rocket Assisted
Projectile Field Artillery/MLRS Live
Fire Capability

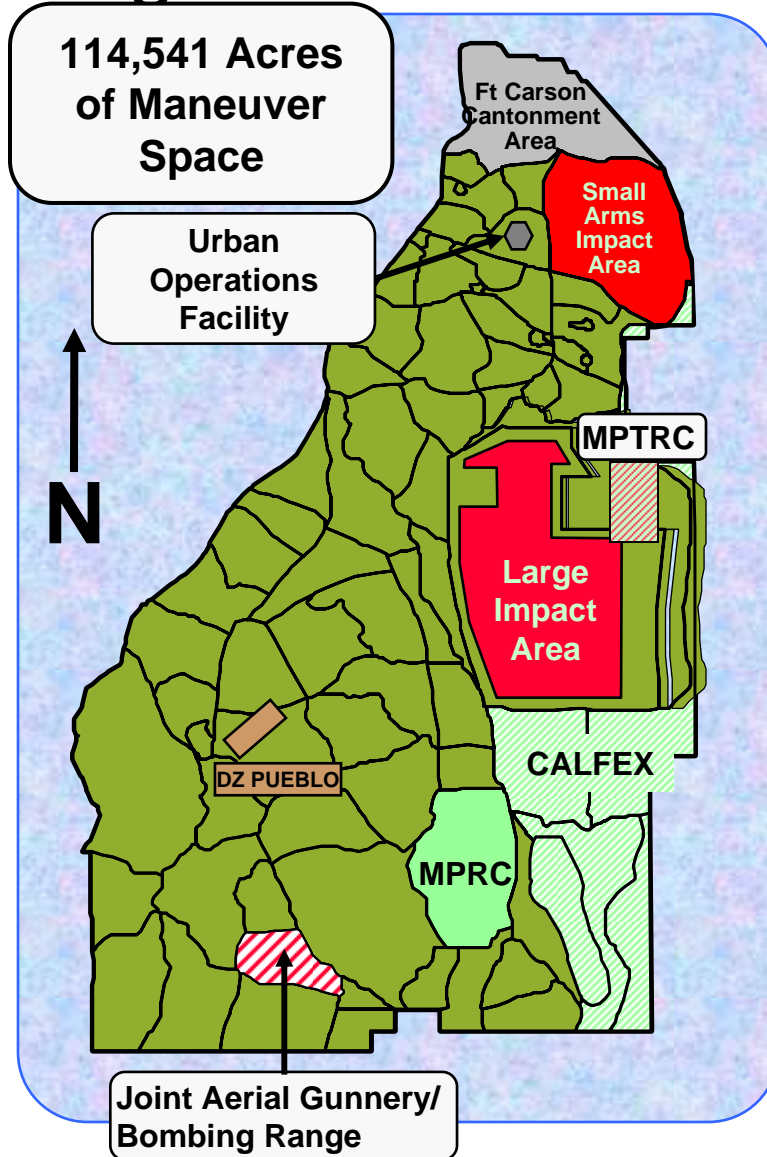

Aviation Air Force and Helicopter
Gunnery Ranges

Tank & Bradley Ranges
(Table Proficiency Firing)

Demolition Ranges

Maneuver/Force-On-Force for
Brigade (-) units

Urban Operations Training Areas

Live Fire Urban Operations

Nuclear, Biological and Chemical
Training Facility

Combat Landing Strips

Airborne Drop Zones

Combined Arms Live Fire
Exercise (CALFEX) Range



***DRAFT DELIBERATIVE DOCUMENT - FOR DISCUSSION PURPOSES ONLY
DO NOT RELEASE UNDER FOIA***





Ft Carson's 21st Century Simulation Capabilities

Today:

- Digital Battle Staff Trainer (DBST)
- SPECTRUM (OOTW/SOSO)
- BN/BDE Simulation (JANUS/BBS)
- Close Combat Tactical Trainer (CCTT)
- Precision Gunnery Trainers (UCOFT)
- UH-60 Flight Simulator
- Engagement Skills Trainer (EST) 2000

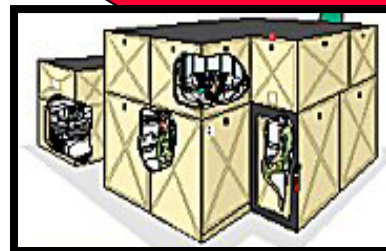
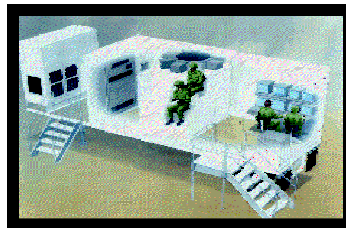

Tomorrow:

- Convoy Trainer FY04
- Fixed Tactical INTERNET FY05
- AH-64D Apache Longbow Flight Simulator FY05
- Battle Command Training Center FY05
- Reconfigurable TOC FY05
- Virtual/Constructive Ft Carson/PCMS Database FY05
- Battle Simulations Center FY06



Ft Carson Virtual/ Constructive Convoy Trainer (FY04)

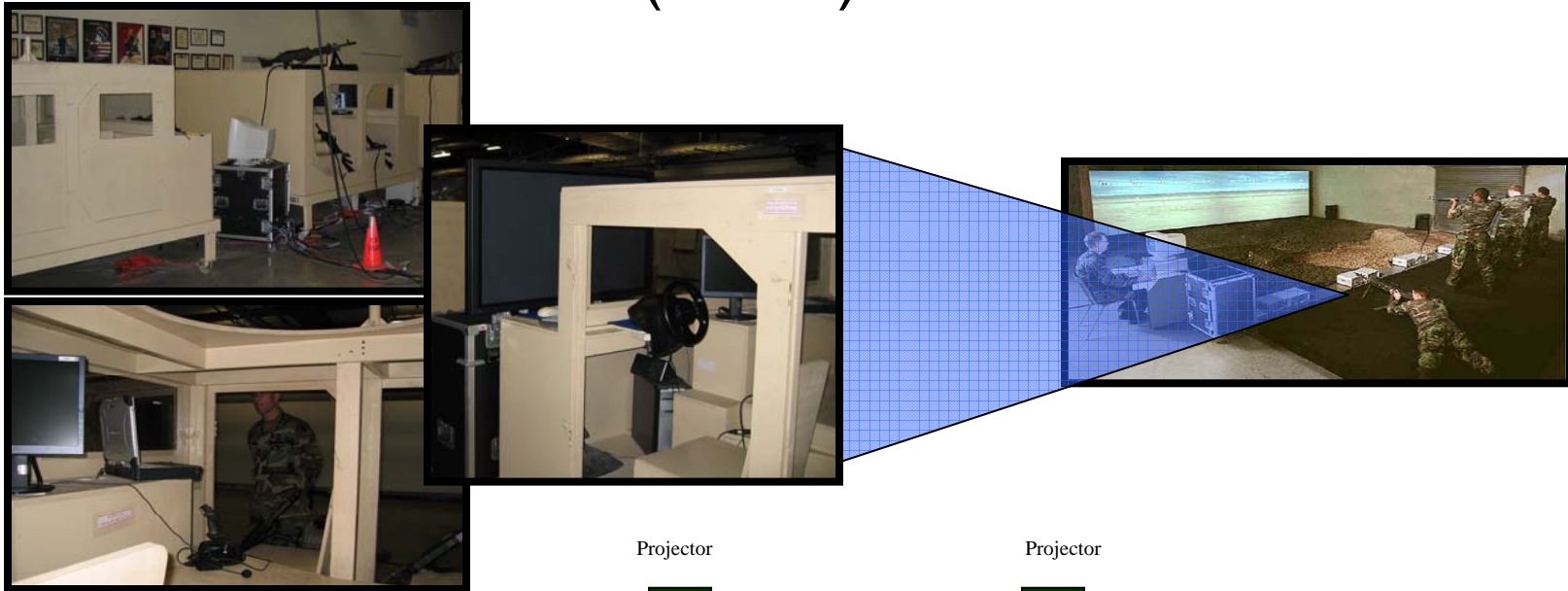

Projector

Projector

Projector

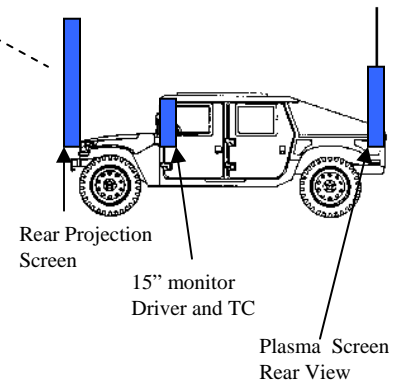
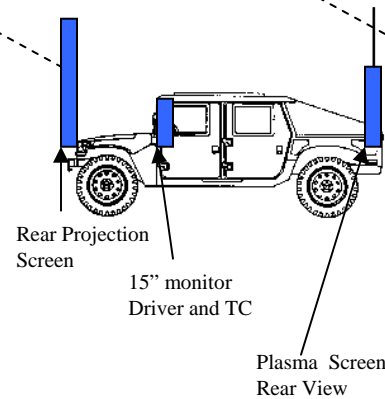
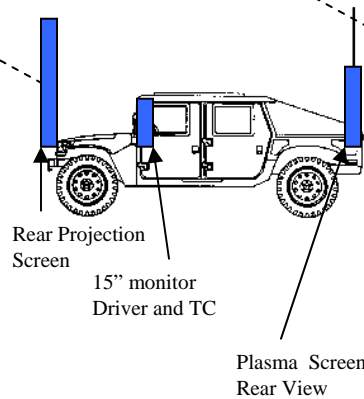
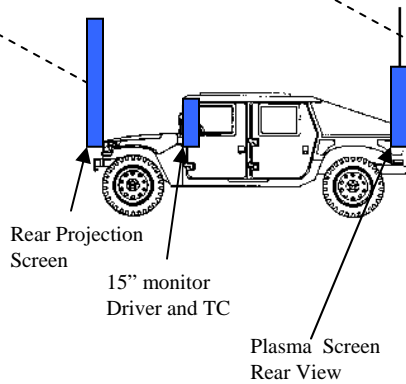



Multi-Component Initiatives/ Activities



Butts Army Airfield



Tenant Units include:

- 4th Squadron, 3rd ACR
- 571st MEDEVAC Co
- 7/158 (USAR)
- 13th Air Support Ops Sq (ASOS)—USAF Weather

} 78 rotary wing aircraft



- Provides DOL Maintenance Support for a 7-state region
- Airfield is Instrument Flight Rules & Night/Night Vision Goggle capable
- Airfield provides 24/7, 363 days a year ATC and Flight Following



Supports Mountain/High Altitude Training Program:

- Three Mountain Training Areas with LZs at 7000 to 13,800 ft MSL
- Highest Paved C-130 assault landing strip in CONUS—5838 ft MSL



Approximately 50,000 movements annually—Transient units include:

- USAFA Flight Training Program
- 160th Special Operations Airborne Regiment
- Army Aviation Test Activity
- UH-60 Flight Simulator supports 8-state region





Colorado Mobilization and Training Equipment Site



- Provides pre-positioned equipment for the training of reserve forces. 80K square foot facility situated on 160 acres of land licensed to Colorado Army National Guard.
- Completed FY03 -- \$13.9M
- National Guard is providing MATES facility to regenerate Active, Reserve and National Guard equipment returning from OIF 1.



Re-Stationing

The COARNG is re-stationing four units in the current MATES complex (Bldg 8110) to improve training opportunities and quality of life for the associated units and soldiers.

B/5-19th SFG(A)

- 110 Soldiers
- Currently at Pueblo Chemical Depot

Det 1 3650th Maint

- 100 soldiers
- Ground Support Equipment
- Currently at Durango, Colorado

947th EN CSE (-)

- 78 soldiers
- 7 D7 CATs, 18 Dump trucks, 4 ACEs
- Currently at Pueblo Chemical Depot

1157th EN (FF)

- 16 soldiers
- 2 Firetrucks
- Currently at Pueblo Chemical Depot



*DRAFT DELIBERATIVE DOCUMENT - FOR DISCUSSION PURPOSES ONLY
DO NOT RELEASE UNDER FOIA*



Centennial Training Site





Centennial Training Site



Training Site Headquarters

- **Billeting for 550**
- **Classrooms**
- **DFAC**
- **Weapon Training Center**
- **FY09 - \$50M**

Professional Development

- **BNCOC Phase I**
- **ANCOC Phase I**
- **CAS3**
- **CGSC**



Education Support Complex



Reserve Initiatives

US Army Reserve Center

- **\$8.95M; completed Mar 04**
- **5025 GSU Headquarters**
- **Offices/Classrooms/Supply**



US Navy Reserve Center

- **200 sailors/month drill at Ft Carson**
- **Support regional mob/demob activities**



Environmental Stewardship and Sustainability



Proactive Environmental Stewardship

- ✓ Fully engaged with all federal and state regulatory agencies
- ✓ Fewer land use restrictions today than 20 years ago resulting in more available maneuver area
- ✓ 14 Threatened/Endangered species with no mission impact
- ✓ 3 Critical habitat proposals vacated
- ✓ Sustained record of credibility
- ✓ Nationally recognized stewardship programs
- ✓ No notices of violation or legal challenges since 2000
- ✓ Environmental requirements non-restrictive allowing for better training opportunities
- ✓ Encroachment mitigation strategies deployed





Environmental Partnerships

- ✓ With 50 federal, state, and local governmental activities, non-governmental organizations (NGOs) and the public
- ✓ Regional pollution prevention initiatives
- ✓ Resource “learning laboratory” utilized by universities and local high schools
- ✓ Lead activity on multi-agency regional resource management task force
- ✓ Direct leadership involvement in NGOs

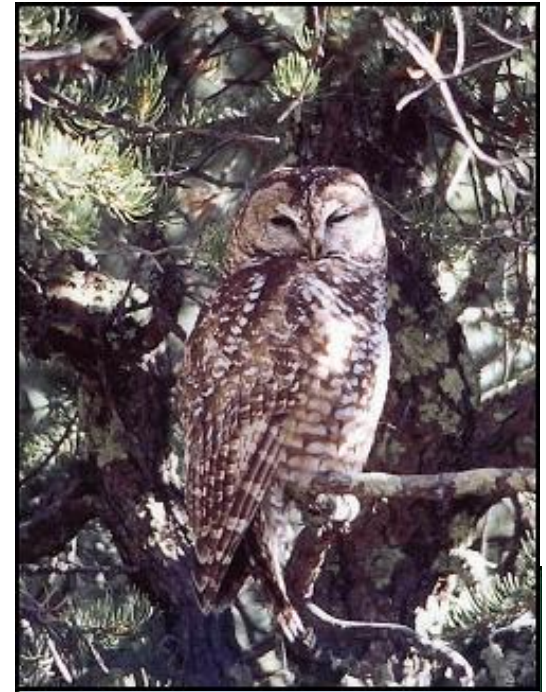



Sustainable Ft Carson

“Using resources to meet the needs of the present without compromising the ability of future Soldiers to meet their mission.”





Army Compatible Use Buffer/Private Lands Initiative

Partnership Involvement:

State, Federal, Local, NGO, Private

Phased Approach:

- Initial Term Lease on 30.0K ac
- Permanent Easement on 14.1K acres with first option to acquire on another 20.3K acres

Future Opportunities:

Initial discussions on 60.0K acres

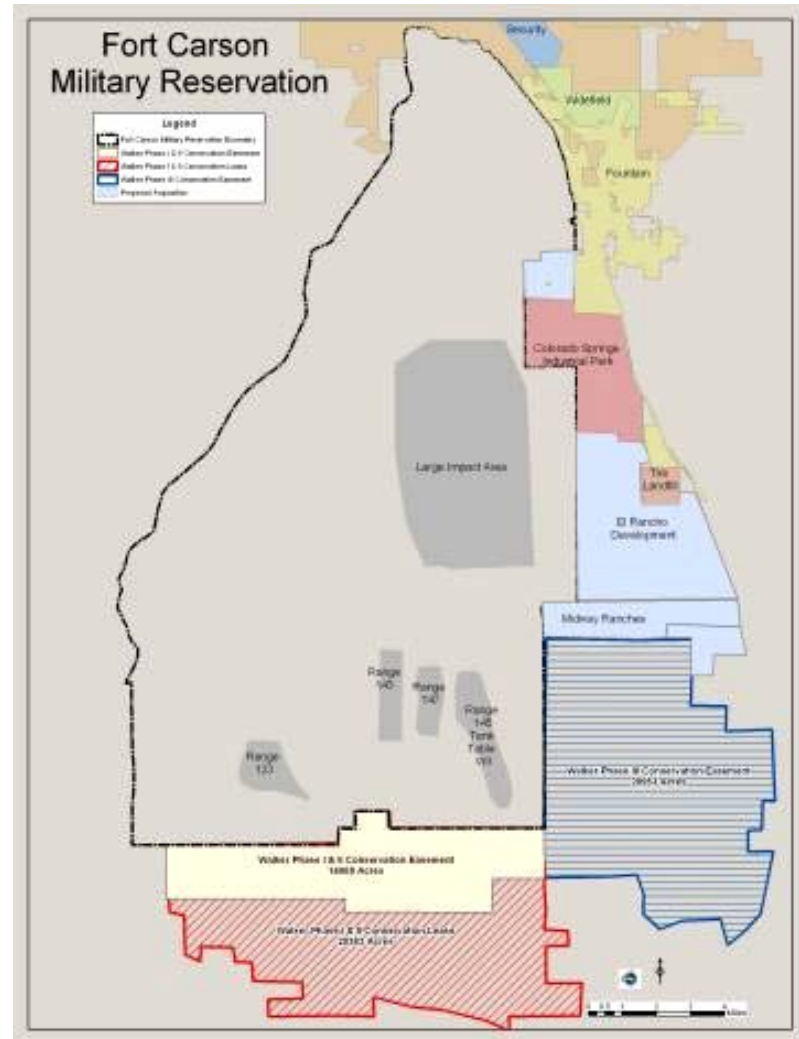



Partnerships



Partnerships

What Ft Carson
Provides
To the Community



- Joint Contracts
- Health Services
- Educational Partnerships
- Support of Community Events
- Military Child Education Coalition
- Community Sustainability Leadership
- Fire and Emergency Services Mutual Aid
- Military Assistance to Safety and Traffic (MAST)





Partnerships

What Ft Carson
Receives
from the Community



Home Front Support
Commercial sponsorships
of MWR events

Ticker-tape parade for returning soldiers
Pikes Peak or Bust Rodeo Proceeds
Private Foundation to build Ft Carson Historical
Center



Highly qualified labor pool
Quality, affordable housing
Community Donations
Military Affairs Council
A great Quality of Life





Health Services



Director of Health Services and Director of Veterinary Services

Health Services

1. Evans Army Community Hospital, Ft Carson, CO
2. Ft Carson, CO
3. Ft W. H. Harrison, Helena, MT
4. LeMieux Multi-Purpose Training Site, Townsend, MT
5. Camp Guernsey, Guernsey, WY
6. Camp Williams, Riverton, UT
7. Dugway Proving Grounds, Salt Lake City, UT
8. Deseret Army Depot, Salt Lake City, UT
9. Tooele Army Depot, Tooele, UT
10. Pueblo Army Depot, Pueblo, CO
11. Rocky Mountain Arsenal, Denver, CO

Veterinary Services

- A. Ft Carson Rocky Mtn Dist Veterinary Command
- B. Ft Bliss Veterinary Branch
- C. Ft Huachuca Veterinary Branch

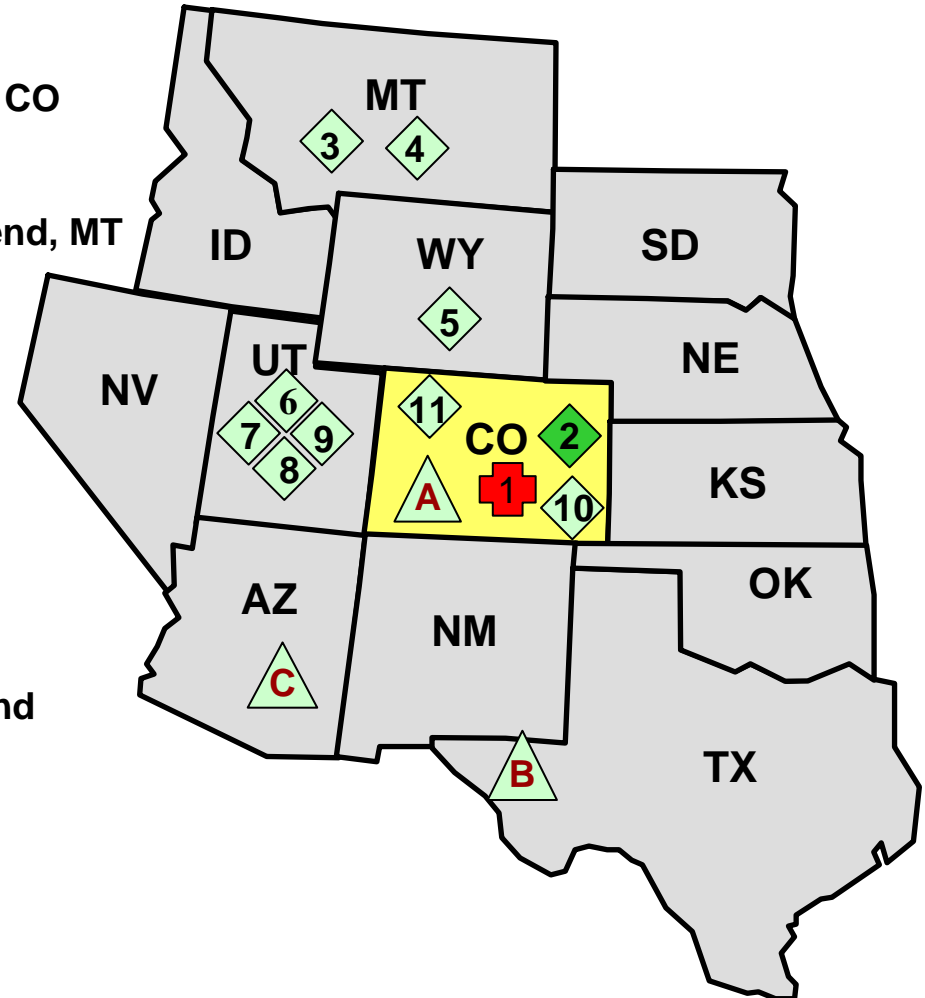



DHS Productivity Overview FY03



Laboratory 343,029
Radiology 513,258
Procedures

MEDDAC Licensed Beds 116
MEDDAC Annual Budget 76.2M Military Pay 30.9 M
DENTAC Annual Budget 3.0M Military Pay 2.7 M
VETCOM Annual Budget 458K Military Pay 884 K



Births 1,170



Pharmacy Rx 680,220



Outpatient Visits 364,132



Inpatient Admissions 4,003

Education

GME/Professional Training: 198 students

Enlisted Phase II MOS: 33 students

Dental 91E: 7 students

91W Transition: 61% transitioned (Ft Carson)



Operating Room Cases
2,135



Annual Dental Value
895,982



Veterinary Outpatient Visits
36,337



DHS National Disaster Medical System (NDMS) Federal Coordinating Center (FCC)

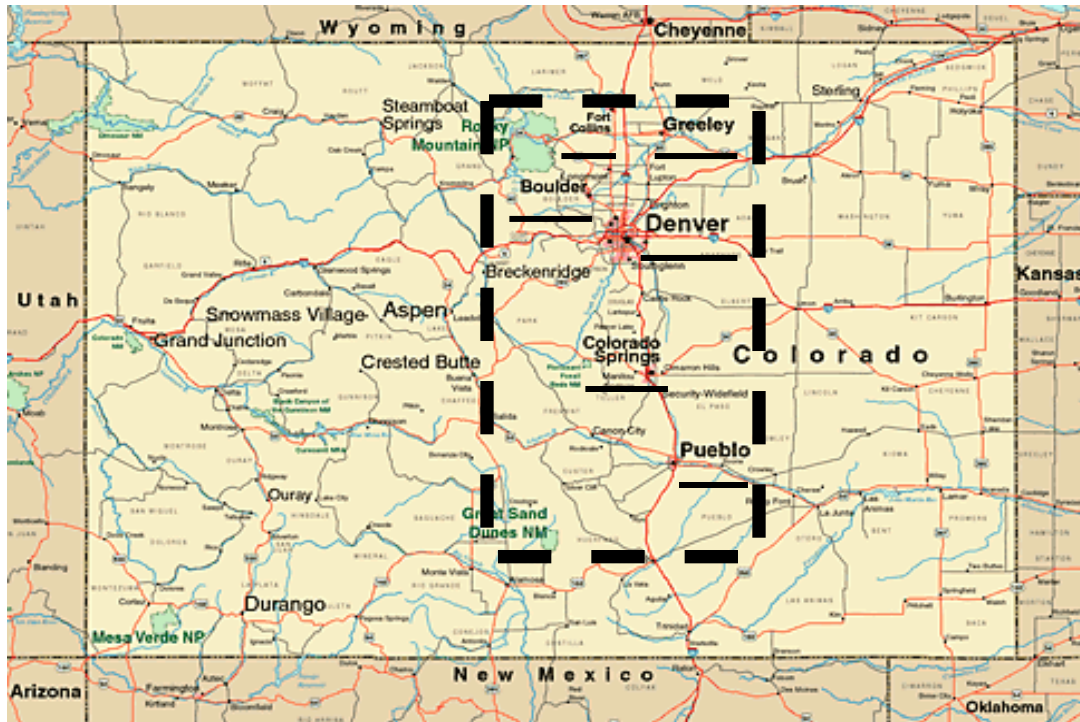

20 NDMS Hospitals

- 14 - Denver Metro Area
- 1 - Boulder
- 1 - FT Collins
- 1 - Greeley
- 2 - Colorado Springs
- 1 - Pueblo

766 minimum beds
1366 maximum beds

A single integrated Nationwide Medical Response System to:

- Supplement state and local medical resources during disasters or major emergencies
- Provide backup medical support to the DOD/VA medical care systems during an overseas conventional conflict/war



Well-being Initiatives



Force Protection Improvements

Access Control Points

- Gates 1, 2, 3, 4, Butts, Crowsfoot complete
- Gates 5 and 20 under construction



- 2 Inbound Lanes (min)
- 2-3 Inspection Lanes
- New Gate House and Guard Booths
- Traffic Control Devices and Video Cameras
- Passive and Active Barriers
- \$ 9M



Information Technology - Potential Army Area Processing Center (APC)

APC concept is to consolidate services “above installation” to reduce total cost of ownership, protect the network and support the Future Force

Ft Carson DOIM has been nominated as a candidate

One of only two Army Garrison DOIMs invited to participate in the second phase of the development model





Residential Communities Initiative(RCI) Current Status

New Houses

- 841/841 built as of 16 Oct 03
- \$100 million

Renovated Houses

- 1603/1843 as of 31 Mar 04
- \$60 million



“Everything you see or touch is new or like new”

New cabinetry, appliances and fixtures in kitchen and bathrooms

New carpeting and floor coverings

Doors, door hardware, and wood trim replaced

Ceiling fans and track lighting

Four phone lines per unit (CAT 5 cable)

Cable TV jack in every room

Renovation of Colonel Housing

- 2 to be completed 2004 (6 are finished)





RCI – Future Plans

- **New Houses – Date TBD**

- 11 CSM qtrs south of Titus
(across from Golf Course)

- 146 4-bedroom E7 qtrs west
of Harr Ave (south of new elementary school)

- 374 condos and town homes (2 bedroom) for E6 and below in
old hospital area

- **Renovated Houses**

- 240 quarters to be finished

- Renovation of LTC/Colonel Housing**

- 2 quarters on Ute Hill to be completed

- Assess rest of units on Ute Hill (those without basements)





Public/Private Ventures



- Ft Carson Historical Center**
- Private funding (\$7M)
 - State/county/city involvement
 - Located next to Gate 1;
accessible to public off post



Car Wash

- Vicinity gate 20
- 4 wand bays
- 2 automatic bays
- FY 04/05

Self Storage Units

- 400+ units
- Costs less than downtown
- FY04/05

.... % of net revenue back to Ft Carson (MWR fund)



Public/Private Ventures

Family Activity Center

- Go-carts, mini golf, batting cages, game room...
- In Iron Horse Park
- Jun 04

Recreational Lodging Facility

- Long range project

Kennel Facility

- Long range project

Indoor Ice Skating Rink

- Long range project



.... % of net revenue back to Ft Carson (MWR fund)



Improvements to the Community

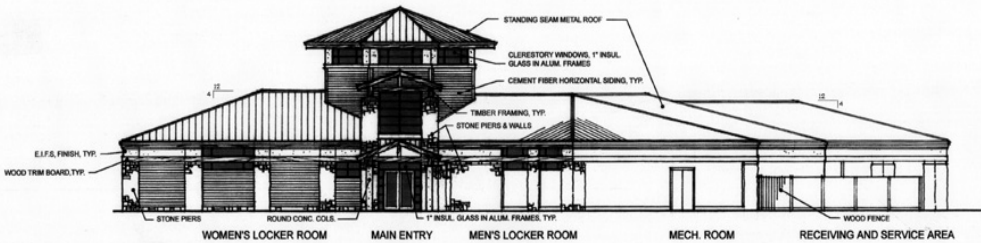

Golf Course Clubhouse

- Replaces existing clubhouse
- FY04 NAF
- \$4.7m
- Pro shop, restaurant, locker rooms

Extreme's/Godfather's Entertainment

- MWR/AAFES Partnership
- FY03
- Self-help Project





Un-Funded Community Improvements (dollars in Millions)

NAF

FY05	Expand Outdoor Recreation Complex	\$ 2.4
FY06	Upgrade Temporary Lodging	8.4
FY07	School-Age Outdoor Sports Complex	5.5

MCA

FY07	Education Center Facility (120,000sf)	22.0
FY08	Child Development Centers (school age)	7.7
FY08	Physical Fitness Center (50,000sf)	13.5
FY08	Child Development Center (school age)	8.0
FY10	Child Development Center (0-6 yrs old)	8.5



Infrastructure Improvements



Funded Improvements (Completed in FY03)

Underground Electrical

- \$3M

Sewer Line Replacement

- \$1.5M

Road Projects

- \$4M



Water Tanks

- Replace 1940's tanks
- \$2M

High Temp Hot Water Lines

- \$30M
- In barracks areas

\$40.5 Funded to Infrastructure



Funded Improvements (Under Construction)

Renovation of 12 motor pools

- OMA \$7.5M
- New high lifts
- Complete in May 05

Roosevelt Field Barracks Complex (3BCT)

- MCA \$43M
- 672 soldiers
- Complete in May 04

Replace Water Lines

- \$1.1M
- Complete Oct 05

Sewer Upgrade

- \$1.5M
- Complete FY05

43rd ASG Dining Facility

- MCA \$7.5M
- 1300 max capacity
- Complete in May 04



\$60.6 M Funded to Infrastructure



Funded Improvements FY04-05

Bulk and Retail Fuel Points

- Ctr Owned, Ctr Operated (COCO)
- FY04



Pinon Canyon Ranges Under Construction

- Machine Gun Range
- Pistol Range
- Grenade Launcher Range
- M-16 Range

Fire Station

- \$4.25M
- Award in FY04; complete FY05
- Replaces two old stations

Vehicle Marshaling Area

- MCA 04
- \$2.15M
- For both wheeled and tracked vehicles

Digital Multi-Purpose Range

- MCA 05
- \$33M

Barracks Complex (Hosp Area)

- MCA05; \$14.2M
- 112 soldiers
- Located next to Evans Hosp

\$53.6 Funded to Infrastructure



Funded Improvements (FYDP Projects)

FY03	Fire Station	\$5.4M
FY04	Vehicle Marshaling Area	\$2.15M
FY05	Barracks Complex	\$14.2M
	Digital Multipurpose Range	\$33M
FY06	Combined Army Collective Tng Fac/ Urban Assault Course Complex	\$28M/
	A/DACG Complex PH-1	\$27M
	Multi-Purpose Machine Gun Range	\$3.5M
	Shoot House (7ID)	\$1.25M
	Shoot House (USASOC)	\$1.25M
FY07	A/DACG Complex PH-II	\$22M
	Modified Record Fire Range	\$2.5M
FY08	Battle Simulation Center – Phase 1	\$25M
	Defense Access Road Project	\$10.2M
FY09	Digital Multipurpose Training Range	\$25M

\$200.45M Funded in the FYDP



Un-Funded Infrastructure Improvements (dollars in Millions)

OMA Funding		
FY04	Butts Army Airfield Runway Repair	\$ 8.8
UMMCA		
05	Ammunition Surveillance Facility	2.8
05	Tactical Unmanned Aerial Vehicle Facility	1.5
MCA		
07	Battle Simulations Center – Phase 1	25.0
07	Barracks Complex (222 soldier spaces)	38.0
07	Vehicle Maintenance Facility Upgrades	12.2
08	Vehicle Maintenance Facility	8.5
08	Fiber Optics Connectivity	7.0
09	Soldier Readiness Processing Center	7.5
09	Centennial Site (Colorado NG)	50.0
10	Battle Simulations Center – Phase 2	19.0



Excess Capacity



Current Excess Capacity

Land	<u>Ft Carson</u>	<u>Pinon Canyon</u>
- Current Buildable Acreage in Existing Cantonment Areas	1,152	368
- Other Developable Acreage	97,354	158,719

Training Ranges (FY02 Usage Data)

- Individual weapons ranges: 16%
- Large caliber gunnery ranges and CALFEX: 38%
- Mortar Firing Points: 2%
- Crew Served: 12%
- Urban and collective ranges: 19%

Training Areas (FY02 Usage Data)

- Heavy Maneuver Areas: 35%
- Light Maneuver and Dismounted: 24%
- Drop Zones: 3%



Summary



SUMMARY

Ft Carson and Pinon Canyon

- Joint training areas: potential for more
- Effective Multi-component training
- Designated Power Projection Platform
- Largest training area next to NTC
 - Expansion under consideration as previously briefed
- Strong Community Partnerships
- Outstanding Quality of Life



Manpower Comparison

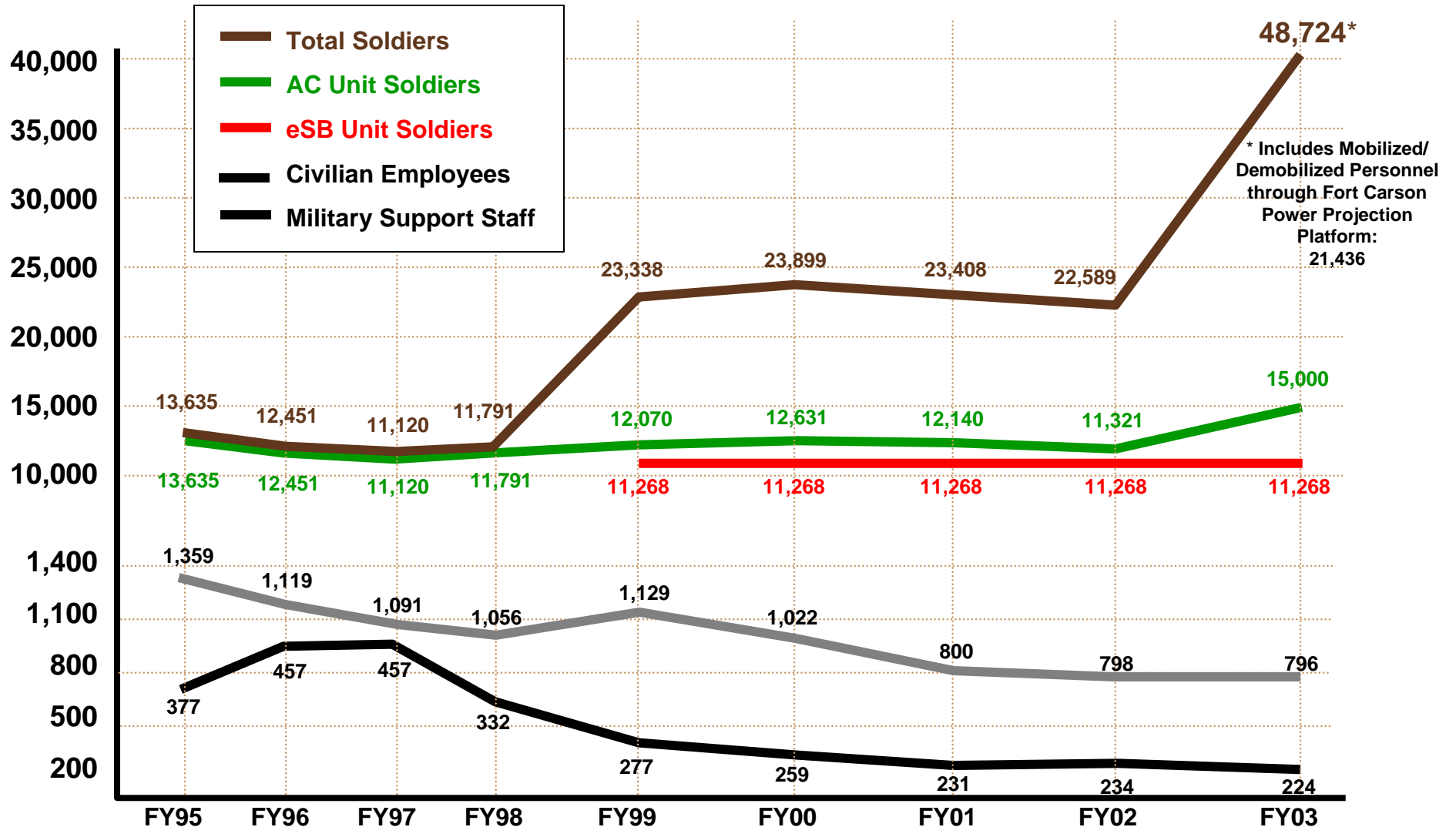

* Includes Mobilized/
Demobilized Personnel
through Fort Carson
Power Projection
Platform:
21,436

4ID Reflagged Ratio 8:1 → 7ID Activated Ratio 17:1 → 9/11 OEF Ratio 47:1 OIF Today



National/Regional Support

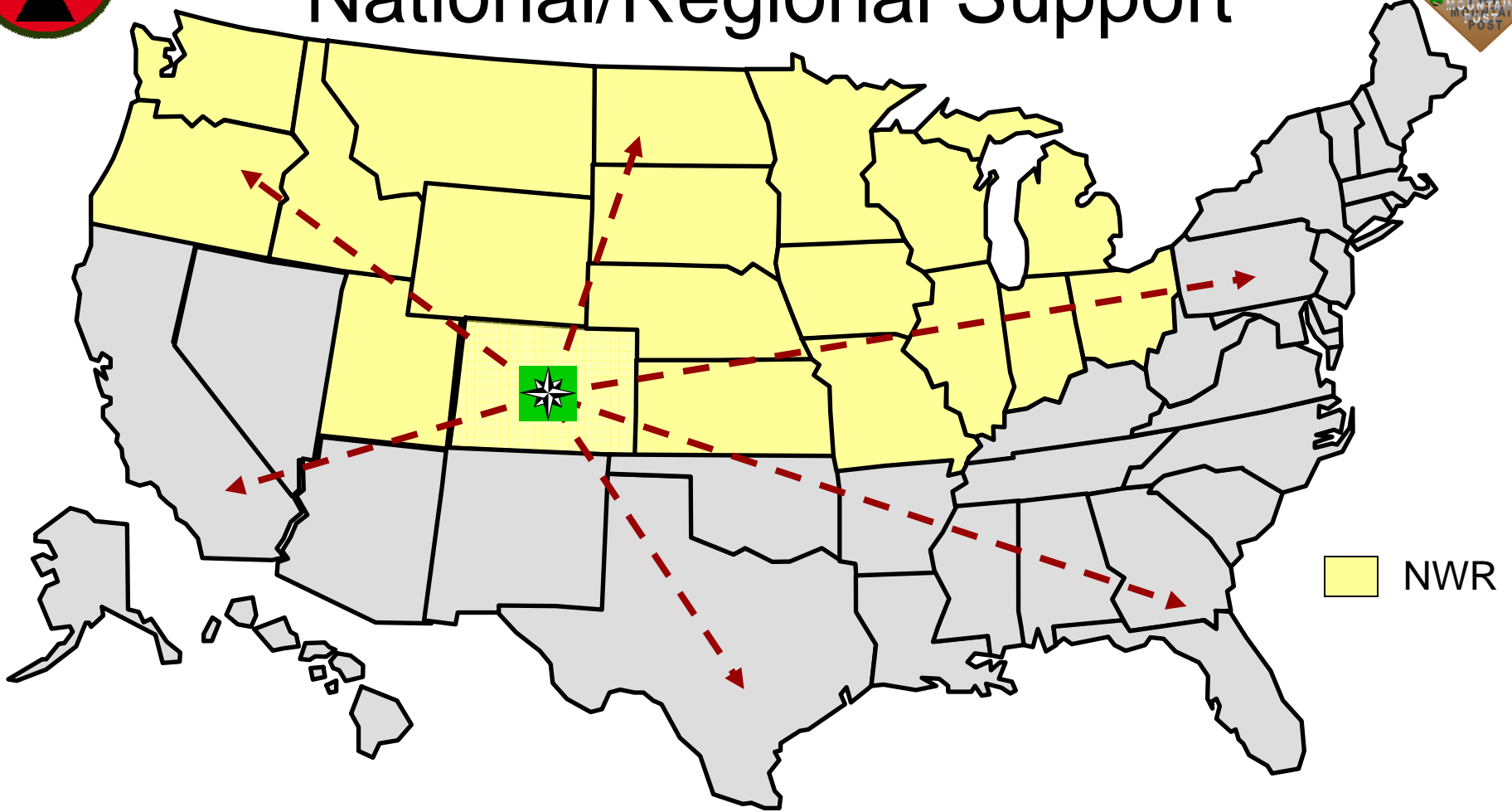

Great Location
Great Training Area

Great Quality of Life
Great Community Support