

5/8-92 JS

DOE-HDBK-1011/4-92
JUNE 1992

DOE FUNDAMENTALS HANDBOOK
ELECTRICAL SCIENCE
Volume 4 of 4

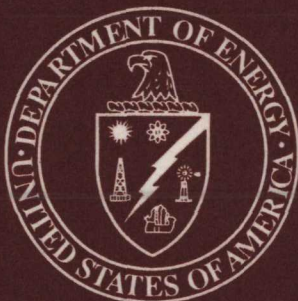

U.S. Department of Energy
Washington, D.C. 20585

FSC-6910

This document has been reproduced directly from the best available copy.

Available to DOE and DOE contractors from the Office of Scientific and Technical Information, P. O. Box 62, Oak Ridge, TN 37831; prices available from (615) 576-8401. FTS 626-8401.

Available to the public from the National Technical Information Service, U.S. Department of Commerce, 5285 Port Royal Rd., Springfield, VA 22161.

DISCLAIMER

This report was prepared as an account of work sponsored by an agency of the United States Government. Neither the United States Government nor any agency Thereof, nor any of their employees, makes any warranty, express or implied, or assumes any legal liability or responsibility for the accuracy, completeness, or usefulness of any information, apparatus, product, or process disclosed, or represents that its use would not infringe privately owned rights. Reference herein to any specific commercial product, process, or service by trade name, trademark, manufacturer, or otherwise does not necessarily constitute or imply its endorsement, recommendation, or favoring by the United States Government or any agency thereof. The views and opinions of authors expressed herein do not necessarily state or reflect those of the United States Government or any agency thereof.

DISCLAIMER

Portions of this document may be illegible in electronic image products. Images are produced from the best available original document.

DOE-HDBK--1011/4-92

DE92 019788

DOE FUNDAMENTALS HANDBOOK
ELECTRICAL SCIENCE
Volume 4 of 4



U.S. Department of Energy
Washington, D.C. 20585

FSC-6910

MASTER

DISTRIBUTION OF THIS DOCUMENT IS UNLIMITED

ABSTRACT

The *Electrical Science Fundamentals Handbook* was developed to assist nuclear facility operating contractors provide operators, maintenance personnel, and the technical staff with the necessary fundamentals training to ensure a basic understanding of electrical theory, terminology, and application. The handbook includes information on alternating current (AC) and direct current (DC) theory, circuits, motors, and generators; AC power and reactive components; batteries; AC and DC voltage regulators; transformers; and electrical test instruments and measuring devices. This information will provide personnel with a foundation for understanding the basic operation of various types of DOE nuclear facility electrical equipment.

Key Words: Training Material, Magnetism, DC Theory, DC Circuits, Batteries, DC Generators, DC Motors, AC Theory, AC Power, AC Generators, Voltage Regulators, AC Motors, Transformers, Test Instruments, Electrical Distribution

FOREWORD

The *Department of Energy (DOE) Fundamentals Handbooks* consist of ten academic subjects, which include Mathematics; Classical Physics; Thermodynamics, Heat Transfer, and Fluid Flow; Instrumentation and Control; Electrical Science; Material Science; Mechanical Science; Chemistry; Engineering Symbolology, Prints, and Drawings; and Nuclear Physics and Reactor Theory. The handbooks are provided as an aid to DOE nuclear facility contractors.

These handbooks were first published as Reactor Operator Fundamentals Manuals in 1985 for use by DOE category A reactors. The subject areas, subject matter content, and level of detail of the Reactor Operator Fundamentals Manuals were determined from several sources. DOE Category A reactor training managers determined which materials should be included, and served as a primary reference in the initial development phase. Training guidelines from the commercial nuclear power industry, results of job and task analyses, and independent input from contractors and operations-oriented personnel were all considered and included to some degree in developing the text material and learning objectives.

The *DOE Fundamentals Handbooks* represent the needs of various DOE nuclear facilities' fundamental training requirements. To increase their applicability to nonreactor nuclear facilities, the Reactor Operator Fundamentals Manual learning objectives were distributed to the Nuclear Facility Training Coordination Program Steering Committee for review and comment. To update their reactor-specific content, DOE Category A reactor training managers also reviewed and commented on the content. On the basis of feedback from these sources, information that applied to two or more DOE nuclear facilities was considered generic and was included. The final draft of each of the handbooks was then reviewed by these two groups. This approach has resulted in revised modular handbooks that contain sufficient detail such that each facility may adjust the content to fit their specific needs.

Each handbook contains an abstract, a foreword, an overview, learning objectives, and text material, and is divided into modules so that content and order may be modified by individual DOE contractors to suit their specific training needs. Each subject area is supported by a separate examination bank with an answer key.

The *DOE Fundamentals Handbooks* have been prepared for the Assistant Secretary for Nuclear Energy, Office of Nuclear Safety Policy and Standards, by the DOE Training Coordination Program. This program is managed by EG&G Idaho, Inc.

OVERVIEW

The *Department of Energy Fundamentals Handbook* entitled *Electrical Science* was prepared as an information resource for personnel who are responsible for the operation of the Department's nuclear facilities. A basic understanding of electricity and electrical systems is necessary for DOE nuclear facility operators, maintenance personnel, and the technical staff to safely operate and maintain the facility and facility support systems. The information in the handbook is presented to provide a foundation for applying engineering concepts to the job. This knowledge will help personnel more fully understand the impact that their actions may have on the safe and reliable operation of facility components and systems.

The *Electrical Science* handbook consists of fifteen modules that are contained in four volumes. The following is a brief description of the information presented in each module of the handbook.

Volume 1 of 4

Module 1 - Basic Electrical Theory

This module describes basic electrical concepts and introduces electrical terminology.

Module 2 - Basic DC Theory

This module describes the basic concepts of direct current (DC) electrical circuits and discusses the associated terminology.

Volume 2 of 4

Module 3 - DC Circuits

This module introduces the rules associated with the reactive components of inductance and capacitance and how they affect DC circuits.

Module 4 - Batteries

This module introduces batteries and describes the types of cells used, circuit arrangements, and associated hazards.

Module 5 - DC Generators

This module describes the types of DC generators and their application in terms of voltage production and load characteristics.

Module 6 - DC Motors

This module describes the types of DC motors and includes discussions of speed control, applications, and load characteristics.

Volume 3 of 4

Module 7 - Basic AC Theory

This module describes the basic concepts of alternating current (AC) electrical circuits and discusses the associated terminology.

Module 8 - AC Reactive Components

This module describes inductance and capacitance and their effects on AC circuits.

Module 9 - AC Power

This module presents power calculations for single-phase and three-phase AC circuits and includes the power triangle concept.

Module 10 - AC Generators

This module describes the operating characteristics of AC generators and includes terminology, methods of voltage production, and methods of paralleling AC generation sources.

Module 11 - Voltage Regulators

This module describes the basic operation and application of voltage regulators.

Volume 4 of 4

Module 12 - AC Motors

This module explains the theory of operation of AC motors and discusses the various types of AC motors and their application.

Module 13 - Transformers

This module introduces transformer theory and includes the types of transformers, voltage/current relationships, and application.

Module 14 - Test Instruments and Measuring Devices

This module describes electrical measuring and test equipment and includes the parameters measured and the principles of operation of common instruments.

Module 15 - Electrical Distribution Systems

This module describes basic electrical distribution systems and includes characteristics of system design to ensure personnel and equipment safety.

The information contained in this handbook is by no means all encompassing. An attempt to present the entire subject of electrical science would be impractical. However, the *Electrical Science* handbook does present enough information to provide the reader with a fundamental knowledge level sufficient to understand the advanced theoretical concepts presented in other subject areas, and to better understand basic system and equipment operations.

**Department of Energy
Fundamentals Handbook**

**ELECTRICAL SCIENCE
Module 12
AC Motors**

TABLE OF CONTENTS

LIST OF FIGURES	ii
LIST OF TABLES	iii
REFERENCES	iv
OBJECTIVES	v
AC MOTOR THEORY	1
Principles of Operation	1
Rotating Field	1
Torque Production	5
Slip	5
Torque	7
Summary	8
AC MOTOR TYPES	9
Induction Motor	9
Single-Phase AC Induction Motors	11
Synchronous Motors	12
Starting a Synchronous Motor	12
Field Excitation	14
Summary	15

LIST OF FIGURES

Figure 1 Three-Phase Stator 2

Figure 2 Rotating Magnetic Field 3

Figure 3 Induction Motor 5

Figure 4 Torque vs Slip 7

Figure 5 Squirrel-Cage Induction Rotor 10

Figure 6 Split-Phase Motor 11

Figure 7 Wound Rotor 12

Figure 8 Torque Angle 13

Figure 9 Synchronous Motor Field Excitation 14

LIST OF TABLES

NONE

REFERENCES

- Gussow, Milton, Schaum's Outline Series, Basic Electricity, McGraw-Hill.
- Academic Program for Nuclear Power Plant Personnel, Volume IV, Columbia, MD: General Physics Corporation, Library of Congress Card #A 326517, 1982.
- Academic Program for Nuclear Power Plant Personnel, Volume II, Columbia, MD: General Physics Corporation, Library of Congress Card #A 326517, 1982.
- Nasar and Unnewehr, Electromechanics and Electric Machines, John Wiley and Sons.
- Van Valkenburgh, Nooger, and Neville, Basic Electricity, Vol. 5, Hayden Book Company.
- Lister, Eugene C., Electric Circuits and Machines, 5th Edition, McGraw-Hill.
- Croft, Carr, Watt, and Summers, American Electricians Handbook, 10th Edition, McGraw-Hill.
- Mason, C. Russel, The Art and Science of Protective Relaying, John Wiley and Sons.
- Mileaf, Harry, Electricity One - Seven, Revised 2nd Edition, Hayden Book Company.
- Buban and Schmitt, Understanding Electricity and Electronics, 3rd Edition, McGraw-Hill.
- Kidwell, Walter, Electrical Instruments and Measurements, McGraw-Hill.

Intentionally Left Blank

TERMINAL OBJECTIVE

- 1.0 Given the type and application of an AC motor, **DESCRIBE** the operating characteristics of that motor including methods of torque production and advantages of that type.

ENABLING OBJECTIVES

- 1.1 **DESCRIBE** how a rotating magnetic field is produced in an AC motor.
- 1.2 **DESCRIBE** how torque is produced in an AC motor.
- 1.3 Given field speed and rotor speed, **CALCULATE** percent slip in an AC motor.
- 1.4 **EXPLAIN** the relationship between speed and torque in an AC induction motor.
- 1.5 **DESCRIBE** how torque is produced in a single-phase AC motor.
- 1.6 **EXPLAIN** why an AC synchronous motor does not have starting torque.
- 1.7 **DESCRIBE** how an AC synchronous motor is started.
- 1.8 **DESCRIBE** the effects of over and under-exciting an AC synchronous motor.
- 1.9 **STATE** the applications of the following types of AC motors:
- a. Induction
 - b. Single-phase
 - c. Synchronous

AC MOTOR THEORY

AC motors are widely used to drive machinery for a wide variety of applications. To understand how these motors operate, a knowledge of the basic theory of operation of AC motors is necessary.

- EO 1.1 **DESCRIBE** how a rotating magnetic field is produced in an AC motor.
 - EO 1.2 **DESCRIBE** how torque is produced in an AC motor.
 - EO 1.3 Given field speed and rotor speed, **CALCULATE** percent slip in an AC motor.
 - EO 1.4 **EXPLAIN** the relationship between slip and torque in an AC induction motor.
-

Principles of Operation

The principle of operation for all AC motors relies on the interaction of a revolving magnetic field created in the stator by AC current, with an opposing magnetic field either induced on the rotor or provided by a separate DC current source. The resulting interaction produces usable torque, which can be coupled to desired loads throughout the facility in a convenient manner. Prior to the discussion of specific types of AC motors, some common terms and principles must be introduced.

Rotating Field

Before discussing how a rotating magnetic field will cause a motor rotor to turn, we must first find out how a rotating magnetic field is produced. Figure 1 illustrates a three-phase stator to which a three-phase AC current is supplied.

The windings are connected in wye. The two windings in each phase are wound in the same direction. At any instant in time, the magnetic field generated by one particular phase will depend on the current through that phase. If the current through that phase is zero, the resulting magnetic field is zero. If the current is at a maximum value, the resulting field is at a maximum value. Since the currents in the three windings are 120° out of phase, the magnetic fields produced will also be 120° out of phase. The three magnetic fields will combine to produce one field, which will act upon the rotor. In an AC induction motor, a magnetic field is induced in the rotor opposite in polarity of the magnetic field in the stator. Therefore, as the magnetic field rotates in the stator, the rotor also rotates to maintain its alignment with the stator's magnetic field. The remainder of this chapter's discussion deals with AC induction motors.

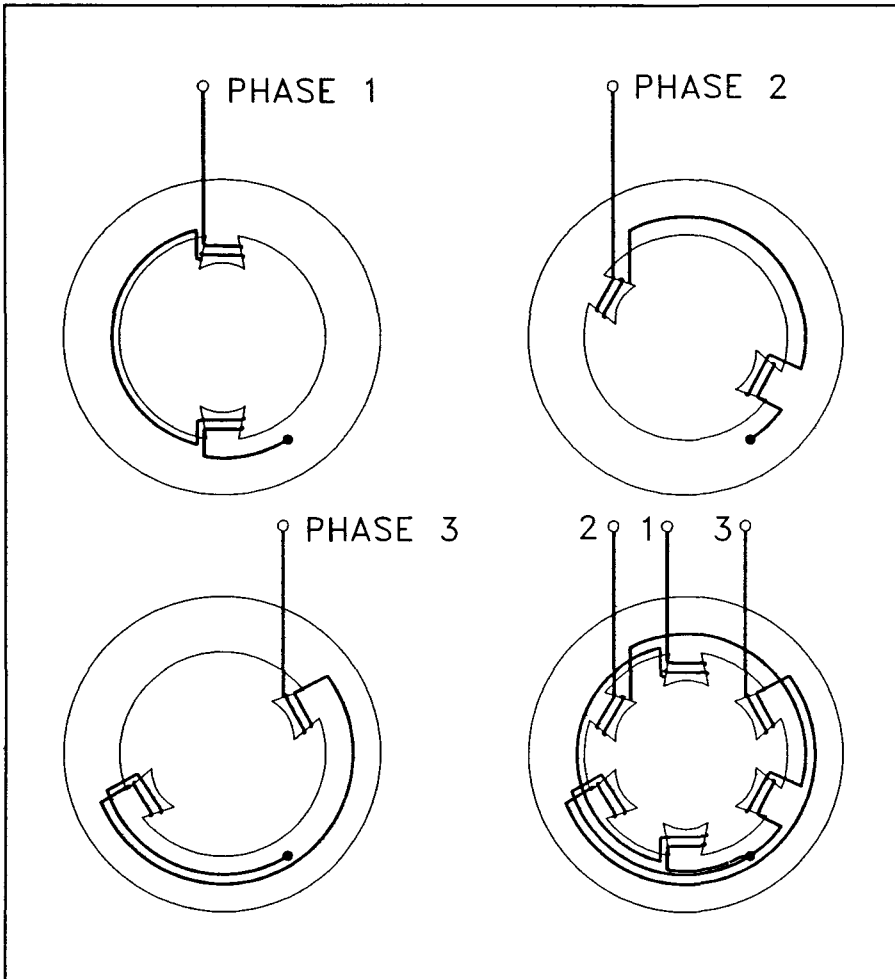

Figure 1 Three-Phase Stator

From one instant to the next, the magnetic fields of each phase combine to produce a magnetic field whose position shifts through a certain angle. At the end of one cycle of alternating current, the magnetic field will have shifted through 360° , or one revolution (Figure 2). Since the rotor has an opposing magnetic field induced upon it, it will also rotate through one revolution.

For purpose of explanation, rotation of the magnetic field is developed in Figure 2 by "stopping" the field at six selected positions, or instances. These instances are marked off at 60° intervals on the sine waves representing the current flowing in the three phases, A, B, and C. For the following discussion, when the current flow in a phase is positive, the magnetic field will develop a north pole at the poles labeled A, B, and C. When the current flow in a phase is negative, the magnetic field will develop a north pole at the poles labeled A', B', and C'.

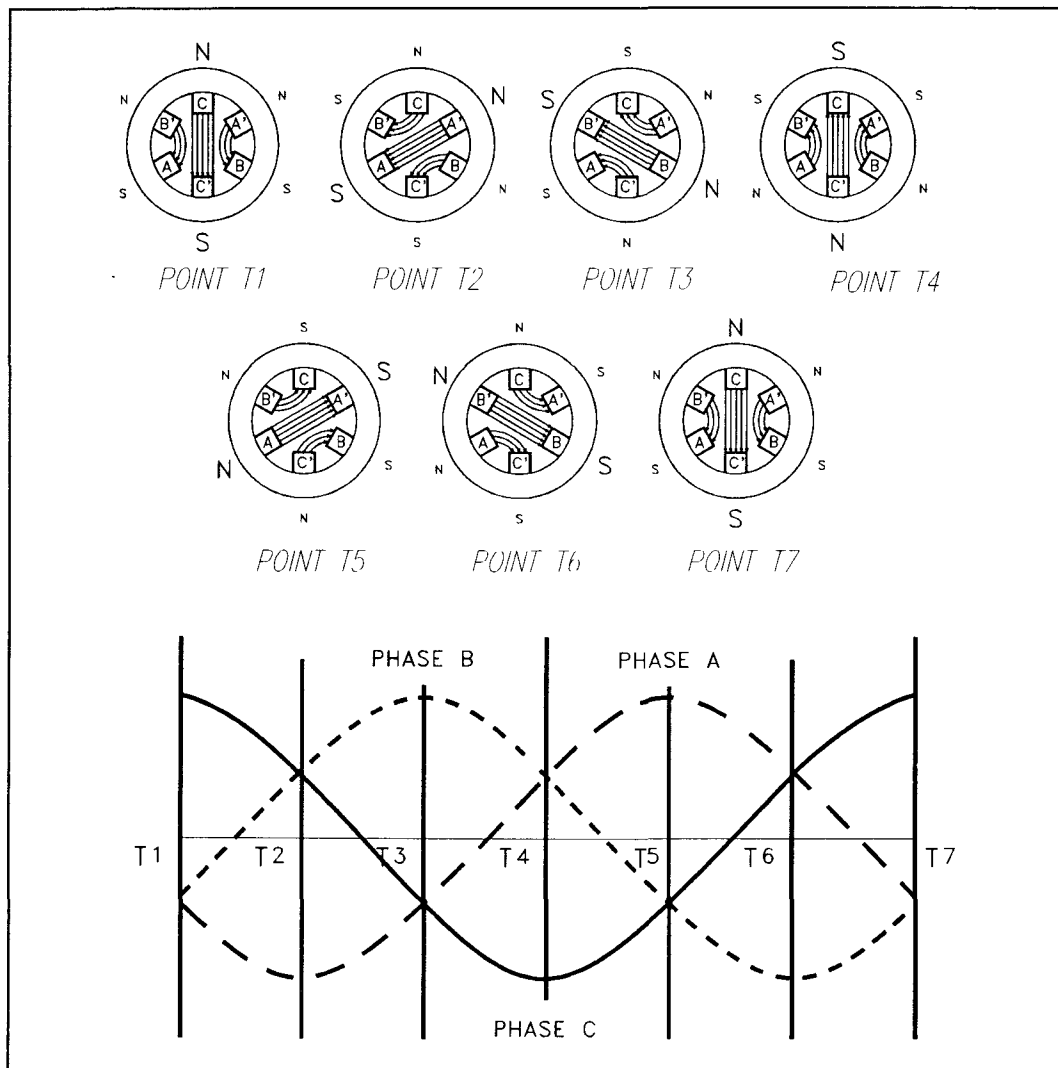

Figure 2 Rotating Magnetic Field

At point T1, the current in phase C is at its maximum positive value. At the same instance, the currents in phases A and B are at half of the maximum negative value. The resulting magnetic field is established vertically downward, with the maximum field strength developed across the C phase, between pole C (north) and pole C' (south). This magnetic field is aided by the weaker fields developed across phases A and B, with poles A' and B' being north poles and poles A and B being south poles.

At Point T2, the current sine waves have rotated through 60 electrical degrees. At this point, the current in phase A has increased to its maximum negative value. The current in phase B has reversed direction and is at half of the maximum positive value. Likewise, the current in phase C has decreased to half of the maximum positive value. The resulting magnetic field is established downward to the left, with the maximum field strength developed across the A phase, between poles A' (north) and A (south). This magnetic field is aided by the weaker fields developed across phases B and C, with poles B and C being north poles and poles B' and C' being south poles. Thus, it can be seen that the magnetic field within the stator of the motor has physically rotated 60°.

At Point T3, the current sine waves have again rotated 60 electrical degrees from the previous point for a total rotation of 120 electrical degrees. At this point, the current in phase B has increased to its maximum positive value. The current in phase A has decreased to half of its maximum negative value, while the current in phase C has reversed direction and is at half of its maximum negative value also. The resulting magnetic field is established upward to the left, with the maximum field strength developed across phase B, between poles B (north) and B' (south). This magnetic field is aided by the weaker fields developed across phases A and C, with poles A' and C' being north poles and poles A and C being south poles. Thus, it can be seen that the magnetic field on the stator has rotated another 60° for a total rotation of 120°.

At Point T4, the current sine waves have rotated 180 electrical degrees from Point T1 so that the relationship of the phase currents is identical to Point T1 except that the polarity has reversed. Since phase C is again at a maximum value, the resulting magnetic field developed across phase C will be of maximum field strength. However, with current flow reversed in phase C the magnetic field is established vertically upward between poles C' (north) and C (south). As can be seen, the magnetic field has now physically rotated a total of 180° from the start.

At Point T5, phase A is at its maximum positive value, which establishes a magnetic field upward to the right. Again, the magnetic field has physically rotated 60° from the previous point for a total rotation of 240°. At Point T6, phase B is at its maximum negative value, which will establish a magnetic field downward to the right. The magnetic field has again rotated 60° from Point T5 for a total rotation of 300°.

Finally, at Point T7, the current is returned to the same polarity and values as that of Point T1. Therefore, the magnetic field established at this instance will be identical to that established at Point T1. From this discussion it can be seen that for one complete revolution of the electrical sine wave (360°), the magnetic field developed in the stator of a motor has also rotated one complete revolution (360°). Thus, you can see that by applying three-phase AC to three windings symmetrically spaced around a stator, a rotating magnetic field is generated.

Torque Production

When alternating current is applied to the stator windings of an AC induction motor, a rotating magnetic field is developed. The rotating magnetic field cuts the bars of the rotor and induces a current in them due to generator action. The direction of this current flow can be found using the left-hand rule for generators. This induced current will produce a magnetic field, opposite in polarity of the stator field, around the conductors of the rotor, which will try to line up with the magnetic field of the stator. Since the stator field is rotating continuously, the rotor cannot line up with, or lock onto, the stator field and, therefore, must follow behind it (Figure 3).

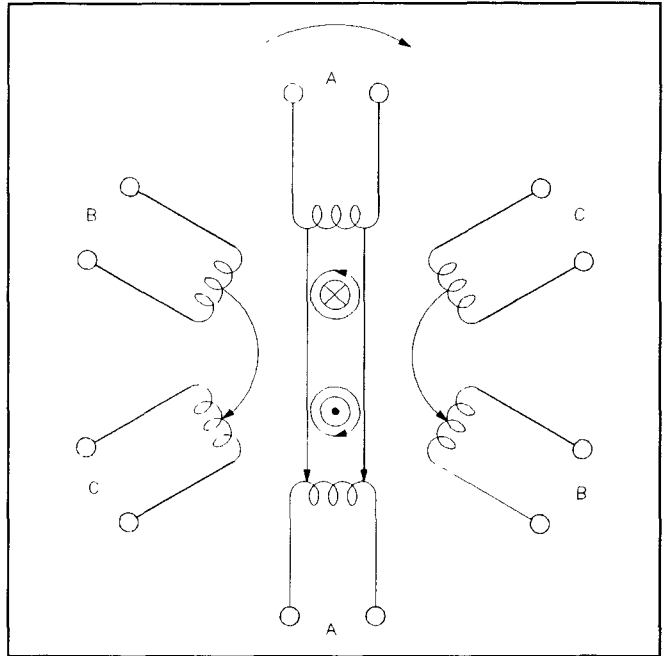

Figure 3 Induction Motor

Slip

It is virtually impossible for the rotor of an AC induction motor to turn at the same speed as that of the rotating magnetic field. If the speed of the rotor were the same as that of the stator, no relative motion between them would exist, and there would be no induced EMF in the rotor. (Recall from earlier modules that relative motion between a conductor and a magnetic field is needed to induce a current.) Without this induced EMF, there would be no interaction of fields to produce motion. The rotor must, therefore, rotate at some speed less than that of the stator if relative motion is to exist between the two.

The percentage difference between the speed of the rotor and the speed of the rotating magnetic field is called *slip*. The smaller the percentage, the closer the rotor speed is to the rotating magnetic field speed. Percent slip can be found by using Equation (12-1).

$$\text{SLIP} = \frac{N_s - N_r}{N_s} \times 100\% \quad (12-1)$$

where

$$\begin{aligned} N_s &= \text{synchronous speed (rpm)} \\ N_R &= \text{rotor speed (rpm)} \end{aligned}$$

The speed of the rotating magnetic field or synchronous speed of a motor can be found by using Equation (12-2).

$$N_s = \frac{120 f}{P} \quad (12-2)$$

where

$$\begin{aligned} N_s &= \text{speed of rotating field (rpm)} \\ f &= \text{frequency of rotor current (Hz)} \\ P &= \text{total number of poles} \end{aligned}$$

Example: A two pole, 60 Hz AC induction motor has a full load speed of 3554 rpm. What is the percent slip at full load?

Solution:

Synchronous speed:

$$N_s = \frac{120 f}{P}$$

$$N_s = \frac{120 (60 \text{ Hz})}{2}$$

$$N_s = 3600 \text{ rpm}$$

Slip:

$$\text{SLIP} = \frac{N_s - N_R}{N_s} \times 100\%$$

$$\text{SLIP} = \frac{3600 - 3554 \text{ rpm}}{3600 \text{ rpm}} \times 100\% = 1.3\%$$

Torque

The torque of an AC induction motor is dependent upon the strength of the interacting rotor and stator fields and the phase relationship between them. Torque can be calculated by using Equation (12-3).

$$T = K \Phi I_R \cos \theta_R \quad (12-3)$$

where

T	= torque (lb-ft)
K	= constant
Φ	= stator magnetic flux
I_R	= rotor current (A)
$\cos \theta_R$	= power factor of rotor

During normal operation, K , Φ , and $\cos \theta_R$ are, for all intents and purposes, constant, so that torque is directly proportional to the rotor current. Rotor current increases in almost direct proportion to slip. The change in torque with respect to slip (Figure 4) shows that, as slip increases from zero to ~10%, the torque increases linearly. As the load and slip are increased beyond full-load torque, the torque will reach a maximum value at about 25% slip. The maximum value of torque is called the *breakdown torque* of the motor. If load is increased beyond this point, the motor will stall and come to a rapid stop. The typical induction motor breakdown torque varies from 200 to 300% of full load torque. Starting torque is the value of torque at 100% slip and is normally 150 to 200% of full-load torque. As the rotor accelerates, torque will increase to breakdown torque and then decrease to the value required to carry the load on the motor at a constant speed, usually between 0-10%.

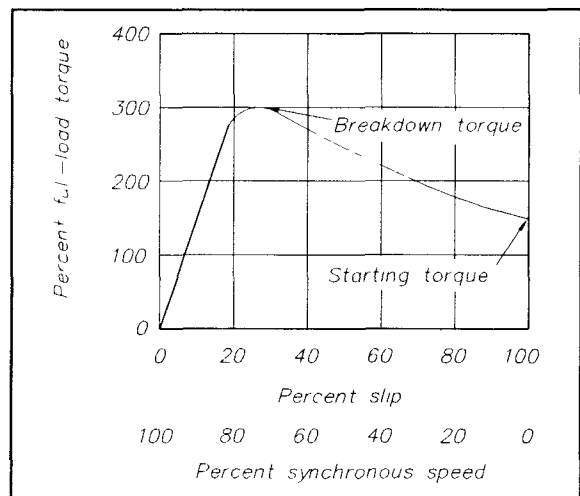

Figure 4 Torque vs Slip

Summary

The important information covered in this chapter is summarized below.

AC Motor Theory Summary

- A magnetic field is produced in an AC motor through the action of the three-phase voltage that is applied. Each of the three phases is 120° from the other phases. From one instant to the next, the magnetic fields combine to produce a magnetic field whose position shifts through a certain angle. At the end of one cycle of alternating current, the magnetic field will have shifted through 360° , or one revolution.
- Torque in an AC motor is developed through interactions with the rotor and the rotating magnetic field. The rotating magnetic field cuts the bars of the rotor and induces a current in them due to generator action. This induced current will produce a magnetic field around the conductors of the rotor, which will try to line up with the magnetic field of the stator.
- Slip is the percentage difference between the speed of the rotor and the speed of the rotating magnetic field.
- In an AC induction motor, as slip increases from zero to $\sim 10\%$, the torque increases linearly. As the load and slip are increased beyond full-load torque, the torque will reach a maximum value at about 25% slip. If load is increased beyond this point, the motor will stall and come to a rapid stop. The typical induction motor breakdown torque varies from 200 to 300% of full-load torque. Starting torque is the value of torque at 100% slip and is normally 150 to 200% of full-load torque.

AC MOTOR TYPES

Various types of AC motors are used for specific applications. By matching the type of motor to the appropriate application, increased equipment performance can be obtained.

- EO 1.5** **DESCRIBE** how torque is produced in a single-phase AC motor.
- EO 1.6** **EXPLAIN** why an AC synchronous motor does not have starting torque.
- EO 1.7** **DESCRIBE** how an AC synchronous motor is started.
- EO 1.8** **DESCRIBE** the effects of over and under-exciting an AC synchronous motor.
- EO 1.9** **STATE** the applications of the following types of AC motors:
- a. **Induction**
 - b. **Single-phase**
 - c. **Synchronous**
-

Induction Motor

Previous explanations of the operation of an AC motor dealt with induction motors. The induction motor is the most commonly used AC motor in industrial applications because of its simplicity, rugged construction, and relatively low manufacturing costs. The reason that the induction motor has these characteristics is because the rotor is a self-contained unit, with no external connections. This type of motor derives its name from the fact that AC currents are induced into the rotor by a rotating magnetic field.

The induction motor rotor (Figure 5) is made of a laminated cylinder with slots in its surface. The windings in the slots are one of two types. The most commonly used is the "squirrel-cage" rotor. This rotor is made of heavy copper bars that are connected at each end by a metal ring made of copper or brass. No insulation is required between the core and the bars because of the low voltages induced into the rotor bars. The size of the air gap between the rotor bars and stator windings necessary to obtain the maximum field strength is small.

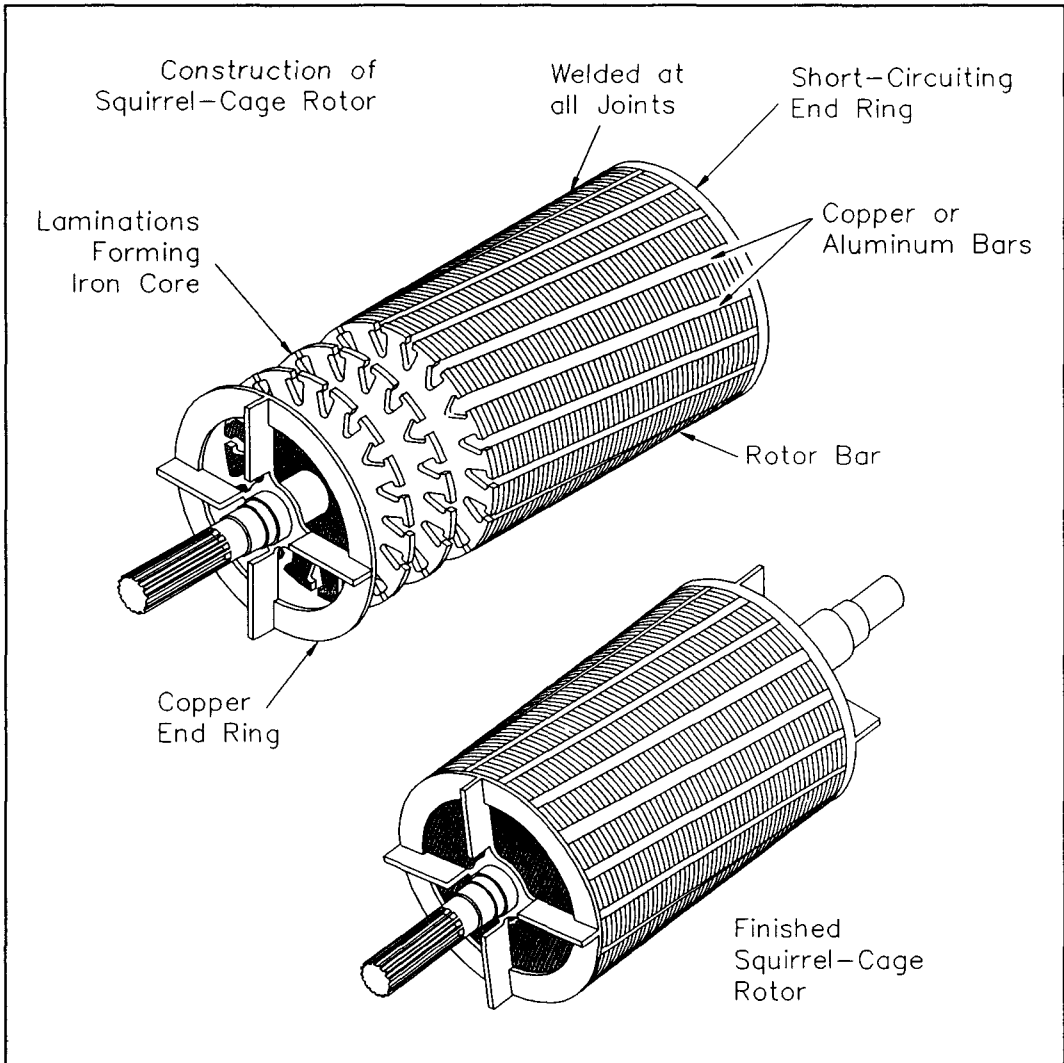

Figure 5 Squirrel-Cage Induction Rotor

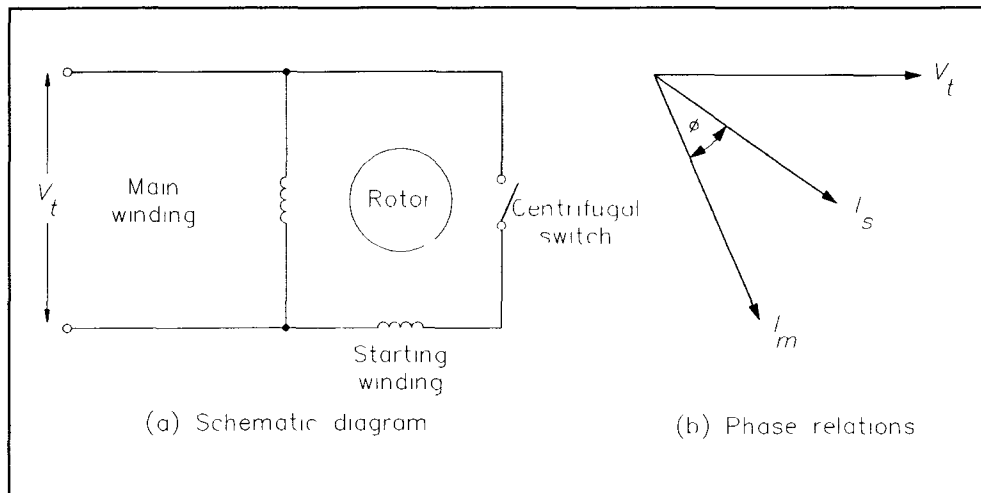

Figure 6 Split-Phase Motor

Single-Phase AC Induction Motors

If two stator windings of unequal impedance are spaced 90 electrical degrees apart and connected in parallel to a single-phase source, the field produced will appear to rotate. This is called phase splitting.

In a split-phase motor, a starting winding is utilized. This winding has a higher resistance and lower reactance than the main winding (Figure 6). When the same voltage V_T is applied to the starting and main windings, the current in the main winding (I_M) lags behind the current of the starting winding I_s (Figure 6). The angle between the two windings is enough phase difference to provide a rotating magnetic field to produce a starting torque. When the motor reaches 70 to 80% of synchronous speed, a centrifugal switch on the motor shaft opens and disconnects the starting winding.

Single-phase motors are used for very small commercial applications such as household appliances and buffers.

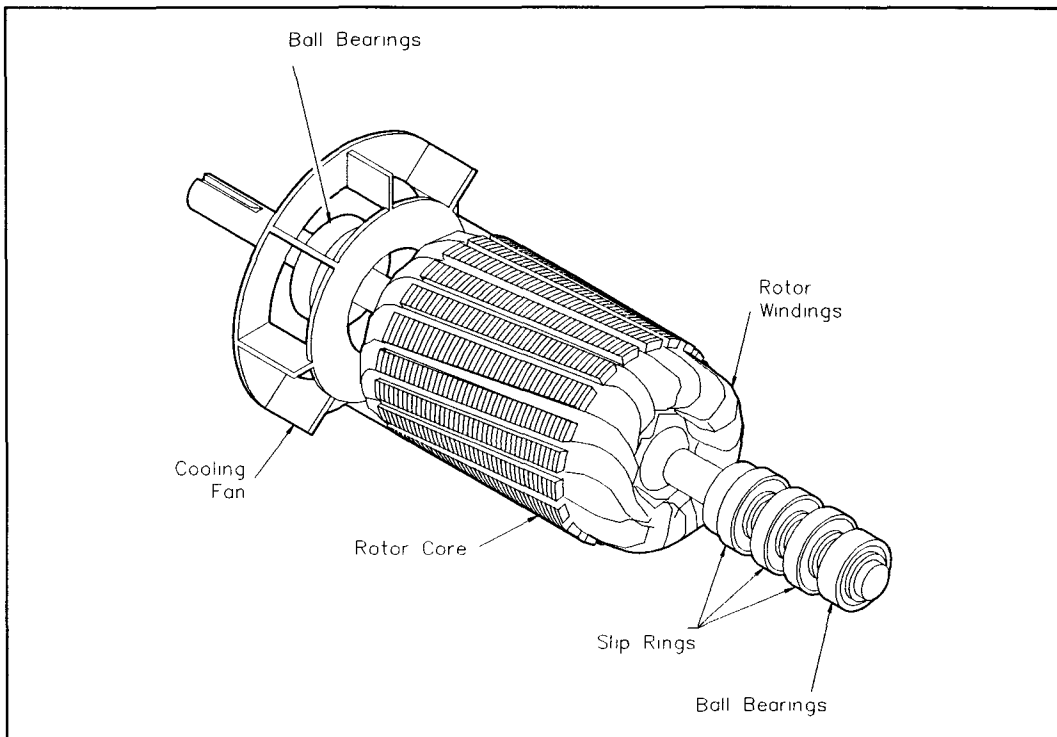

Figure 7 Wound Rotor

Synchronous Motors

Synchronous motors are like induction motors in that they both have stator windings that produce a rotating magnetic field. Unlike an induction motor, the synchronous motor is excited by an external DC source and, therefore, requires slip rings and brushes to provide current to the rotor. In the synchronous motor, the rotor locks into step with the rotating magnetic field and rotates at synchronous speed. If the synchronous motor is loaded to the point where the rotor is pulled out of step with the rotating magnetic field, no torque is developed, and the motor will stop. A synchronous motor is not a self-starting motor because torque is only developed when running at synchronous speed; therefore, the motor needs some type of device to bring the rotor to synchronous speed.

Synchronous motors use a wound rotor. This type of rotor contains coils of wire placed in the rotor slots. Slip rings and brushes are used to supply current to the rotor. (Figure 7).

Starting a Synchronous Motor

A synchronous motor may be started by a DC motor on a common shaft. When the motor is brought to synchronous speed, AC current is applied to the stator windings. The DC motor now acts as a DC generator and supplies DC field excitation to the rotor of the synchronous motor. The load may now be placed on the synchronous motor. Synchronous motors are more often started by means of a squirrel-cage winding embedded in the face of the rotor poles. The motor is then started as an induction motor and brought to $\sim 95\%$ of synchronous speed, at which time direct current is applied, and the motor begins to pull into synchronism. The torque required to pull the motor into synchronism is called the pull-in torque.

As we already know, the synchronous motor rotor is locked into step with the rotating magnetic field and must continue to operate at synchronous speed for all loads. During no-load conditions, the center lines of a pole of the rotating magnetic field and the DC field pole coincide (Figure 8a). As load is applied to the motor, there is a backward shift of the rotor pole, relative to the stator pole (Figure 8b). There is no change in speed. The angle between the rotor and stator poles is called the *torque angle* (α).

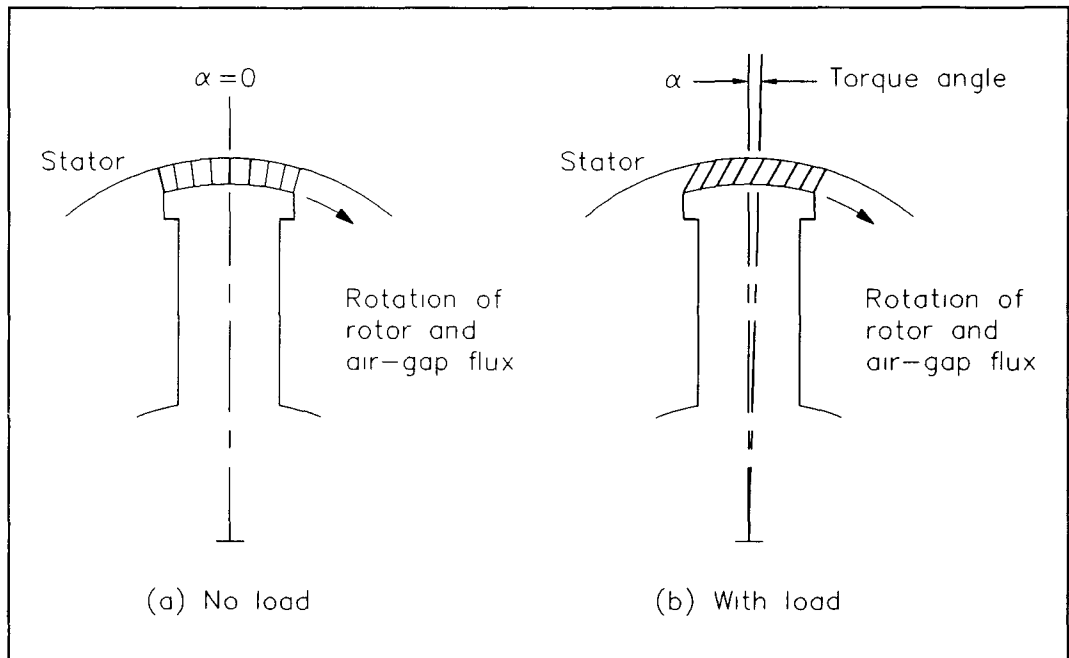

Figure 8 Torque Angle

If the mechanical load on the motor is increased to the point where the rotor is pulled out of synchronism ($\alpha \cong 90^\circ$), the motor will stop. The maximum value of torque that a motor can develop without losing synchronism is called its pull-out torque.

Field Excitation

For a constant load, the power factor of a synchronous motor can be varied from a leading value to a lagging value by adjusting the DC field excitation (Figure 9). Field excitation can be adjusted so that $PF = 1$ (Figure 9a). With a constant load on the motor, when the field excitation is increased, the counter EMF (V_G) increases. The result is a change in phase between stator current (I) and terminal voltage (V_t), so that the motor operates at a leading power factor (Figure 9b). V_p in Figure 9 is the voltage drop in the stator winding's due to the impedance of the windings and is 90° out of phase with the stator current. If we reduce field excitation, the motor will operate at a lagging power factor (Figure 9c). Note that torque angle, α , also varies as field excitation is adjusted to change power factor.

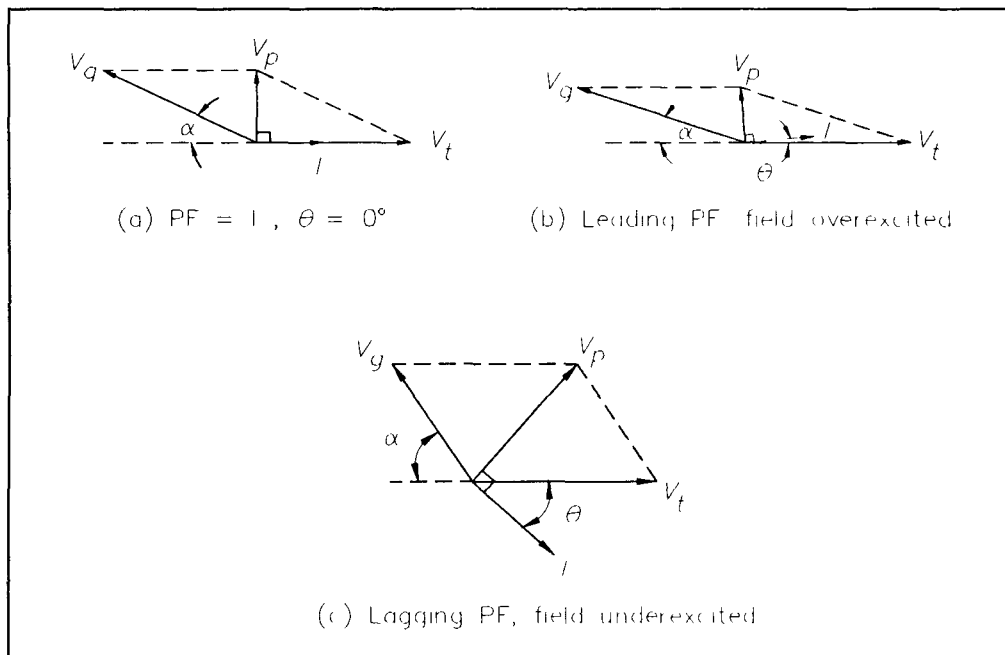

Figure 9 Synchronous Motor Field Excitation

Synchronous motors are used to accommodate large loads and to improve the power factor of transformers in large industrial complexes.

Summary

The important information in this chapter is summarized below.

AC Motor Types Summary

- In a split-phase motor, a starting winding is utilized. This winding has a higher resistance and lower reactance than the main winding. When the same voltage (V_T) is applied to the starting and main windings, the current in the main winding lags behind the current of the starting winding. The angle between the two windings is enough phase difference to provide a rotating magnetic field to produce a starting torque.
- A synchronous motor is not a self-starting motor because torque is only developed when running at synchronous speed.
- A synchronous motor may be started by a DC motor on a common shaft or by a squirrel-cage winding imbedded in the face of the rotor poles.
- Keeping the same load, when the field excitation is increased on a synchronous motor, the motor operates at a leading power factor. If we reduce field excitation, the motor will operate at a lagging power factor.
- The induction motor is the most commonly used AC motor in industrial applications because of its simplicity, rugged construction, and relatively low manufacturing costs.
- Single-phase motors are used for very small commercial applications such as household appliances and buffers.
- Synchronous motors are used to accommodate large loads and to improve the power factor of transformers in large industrial complexes.

Intentionally Left Blank

**Department of Energy
Fundamentals Handbook**

**ELECTRICAL SCIENCE
Module 13
Transformers**

TABLE OF CONTENTS

LIST OF FIGURES	ii
LIST OF TABLES	iii
REFERENCES	iv
OBJECTIVES	v
TRANSFORMER THEORY	1
Mutual Induction	1
Turns Ratio	2
Impedance Ratio	2
Efficiency	3
Theory of Operation	3
Voltage Ratio	5
Current Ratio	7
Three-Phase Transformer Connections	8
Delta Connection	8
Wye Connection	8
Combinations of Delta and Wye Transformer Connections	9
Transformer Losses and Efficiency	11
Transformer Operation Under No-Load	13
Coil Polarity	14
Summary	16
TRANSFORMER TYPES	17
Types of Transformers	17
Distribution Transformer	17
Power Transformer	17
Control Transformer	18
Auto Transformer	18
Isolation Transformer	18
Instrument Potential Transformer	19
Instrument Current Transformer	19
Summary	20

LIST OF FIGURES

Figure 1 Core-Type Transformer 4

Figure 2 Example 1 Transformer 5

Figure 3 Delta Connection 8

Figure 4 Wye Connection 9

Figure 5 3 ϕ Transformer Connections 9

Figure 6 Open Circuit Secondary 13

Figure 7 Polarity of Transformer Coils 15

Figure 8 Auto Transformer Schematic 18

LIST OF TABLES

Table 1 Voltage and Current Ratings of Transformers 10

REFERENCES

- Gussow, Milton, Schaum's Outline Series, Basic Electricity, McGraw-Hill.
- Academic Program for Nuclear Power Plant Personnel, Volume IV, Columbia, MD: General Physics Corporation, Library of Congress Card #A 326517, 1982.
- Nasar and Unnewehr, Electromechanics and Electric Machines, John Wiley and Sons.
- Van Valkenburgh, Nooger, and Neville, Basic Electricity, Vol. 5, Hayden Book Company.
- Croft, Carr, Watt, and Summers, American Electricians Handbook, 10th Edition, McGraw-Hill.
- Mileaf, Harry, Electricity One - Seven, Revised 2nd Edition, Hayden Book Company.
- Buban and Schmitt, Understanding Electricity and Electronics, 3rd Edition, McGraw-Hill.

TERMINAL OBJECTIVE

- 1.0 Given the type of a transformer, **DESCRIBE** the operating characteristics and applications for that transformer type.

ENABLING OBJECTIVES

- 1.1 **DEFINE** the following terms as they pertain to transformers:
- a. Mutual induction
 - b. Turns ratio
 - c. Impedance ratio
 - d. Efficiency
- 1.2 **DESCRIBE** the differences between a wye-connected and delta-connected transformer.
- 1.3 Given the type of connection and turns ratios for the primary and secondary of a transformer, **CALCULATE** voltage, current, and power for each of the following types:
- a. $\Delta - \Delta$
 - b. $\Delta - Y$
 - c. $Y - \Delta$
 - d. $Y - Y$
- 1.4 **STATE** the applications of each of the following types of transformers:
- a. Distribution
 - b. Power
 - c. Control
 - d. Auto
 - e. Isolation
 - f. Instrument potential
 - g. Instrument current

Intentionally Left Blank

TRANSFORMER THEORY

Transformers are used extensively for AC power transmissions and for various control and indication circuits. Knowledge of the basic theory of how these components operate is necessary to understand the role transformers play in today's nuclear facilities.

- EO 1.1** **DEFINE** the following terms as they pertain to transformers:
- a. **Mutual induction**
 - b. **Turns ratio**
 - c. **Impedance ratio**
 - d. **Efficiency**
- EO 1.2** **DESCRIBE** the differences between a wye-connected and delta-connected transformer.
- EO 1.3** Given the type of connection and turns ratios for the primary and secondary of a transformer, **CALCULATE** voltage, current, and power for each of the following types:
- a. $\Delta - \Delta$
 - b. $\Delta - Y$
 - c. $Y - \Delta$
 - d. $Y - Y$
-

Mutual Induction

If flux lines from the expanding and contracting magnetic field of one coil cut the windings of another nearby coil, a voltage will be induced in that coil. The inducing of an EMF in a coil by magnetic flux lines generated in another coil is called *mutual induction*. The amount of electromotive force (EMF) that is induced depends on the relative positions of the two coils.

Turns Ratio

Each winding of a transformer contains a certain number of turns of wire. The *turns ratio* is defined as the ratio of turns of wire in the primary winding to the number of turns of wire in the secondary winding. Turns ratio can be expressed using Equation (13-1).

$$\text{Turns ratio} = \frac{N_p}{N_s} \quad (13-1)$$

where

$$\begin{aligned} N_p &= \text{number of turns on the primary coil} \\ N_s &= \text{number of turns on the secondary coil} \end{aligned}$$

The coil of a transformer that is energized from an AC source is called the primary winding (coil), and the coil that delivers this AC to the load is called the secondary winding (coil) (Figure 1).

Impedance Ratio

Maximum power is transferred from one circuit to another through a transformer when the impedances are equal, or matched. A transformer winding constructed with a definite turns ratio can perform an impedance matching function. The turns ratio will establish the proper relationship between the primary and secondary winding impedances. The ratio between the two impedances is referred to as the *impedance ratio* and is expressed by using Equation (13-2).

$$\left(\frac{N_p}{N_s} \right)^2 = \frac{Z_p}{Z_s} \quad (13-2)$$

Another way to express the impedance ratio is to take the square root of both sides of Equation (13-2). This puts the ratio in terms of the turns ratio, which is always given for a transformer.

$$\frac{N_p}{N_s} = \sqrt{\frac{Z_p}{Z_s}}$$

where

$$\begin{aligned} N_p &= \text{number of turns in the primary} \\ N_s &= \text{number of turns in the secondary} \\ Z_p &= \text{impedance of primary} \\ Z_s &= \text{impedance of secondary} \end{aligned}$$

Efficiency

Efficiency of a transformer is the ratio of the power output to the power input, as illustrated by Equation (13-3).

$$\text{Efficiency} = \frac{\text{Power Output}}{\text{Power Input}} = \frac{P_s}{P_p} \times 100 \quad (13-3)$$

where

P_s = power of secondary

P_p = power of primary

Theory of Operation

A transformer works on the principle that energy can be transferred by magnetic induction from one set of coils to another set by means of a varying magnetic flux. The magnetic flux is produced by an AC source.

The coil of a transformer that is energized from an AC source is called the primary winding (coil), and the coil that delivers this AC to the load is called the secondary winding (coil) (Figure 1).

In Figure 1, the primary and secondary coils are shown on separate legs of the magnetic circuit so that we can easily understand how the transformer works. Actually, half of the primary and secondary coils are wound on each of the two legs, with sufficient insulation between the two coils and the core to properly insulate the windings from one another and the core. A transformer wound, such as in Figure 1, will operate at a greatly reduced efficiency due to the magnetic leakage. Magnetic leakage is the part of the magnetic flux that passes through either one of the coils, but not through both. The larger the distance between the primary and secondary windings, the longer the magnetic circuit and the greater the leakage.

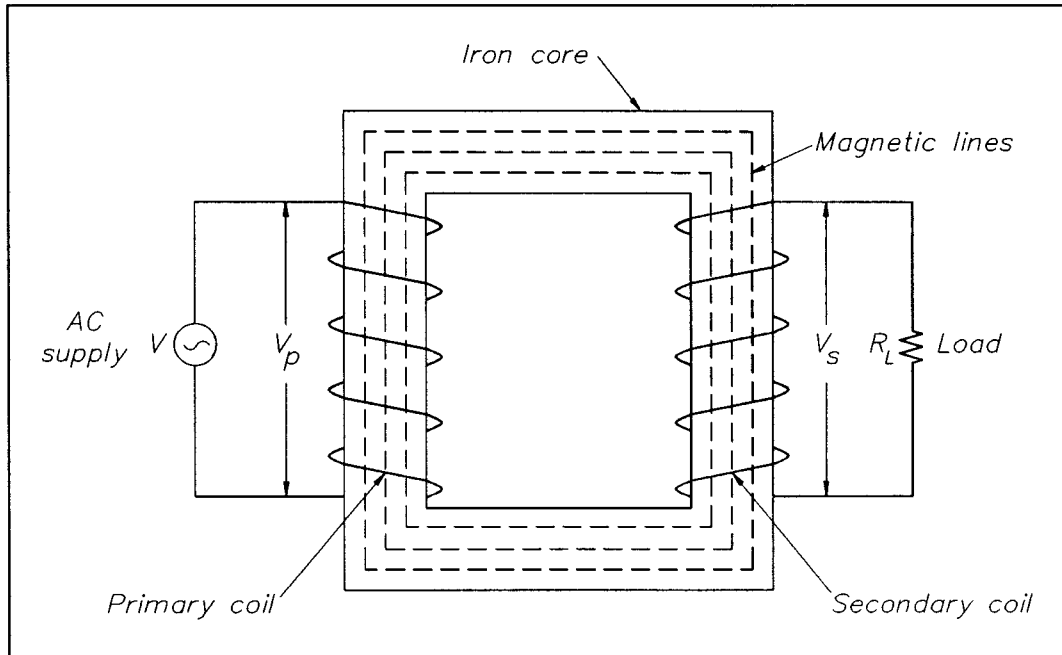

Figure 1 Core-Type Transformer

When alternating voltage is applied to the primary winding, an alternating current will flow that will magnetize the magnetic core, first in one direction and then in the other direction. This alternating flux flowing around the entire length of the magnetic circuit induces a voltage in both the primary and secondary windings. Since both windings are linked by the same flux, the voltage induced per turn of the primary and secondary windings must be the same value and same direction. This voltage opposes the voltage applied to the primary winding and is called counter-electromotive force (CEMF).

Voltage Ratio

The voltage of the windings in a transformer is directly proportional to the number of turns on the coils. This relationship is expressed in Equation (13-4).

$$\frac{V_P}{V_S} = \frac{N_P}{N_S} \quad (13-4)$$

where

- V_P = voltage on primary coil
- V_S = voltage on secondary coil
- N_P = number of turns on the primary coil
- N_S = number of turns on the secondary coil

The ratio of primary voltage to secondary voltage is known as the *voltage ratio* (VR). As mentioned previously, the ratio of primary turns of wire to secondary turns of wire is known as the *turns ratio* (TR). By substituting into the Equation (13-4), we find that the voltage ratio is equal to the turns ratio.

$$VR = TR$$

A voltage ratio of 1:5 means that for each volt on the primary, there will be 5 volts on the secondary. If the secondary voltage of a transformer is greater than the primary voltage, the transformer is referred to as a "step-up" transformer. A ratio of 5:1 means that for every 5 volts on the primary, there will only be 1 volt on the secondary. When secondary voltage is less than primary voltage, the transformer is referred to as a "step-down" transformer.

Example 1: A transformer (Figure 2) reduces voltage from 120 volts in the primary to 6 volts in the secondary. If the primary winding has 300 turns and the secondary has 15 turns, find the voltage and turns ratio.

Solution:

$$VR = \frac{V_P}{V_S} = \frac{120}{60} = \frac{20}{1} = 20:1$$

$$TR = \frac{N_P}{N_S} = \frac{300}{15} = \frac{20}{1} = 20:1$$

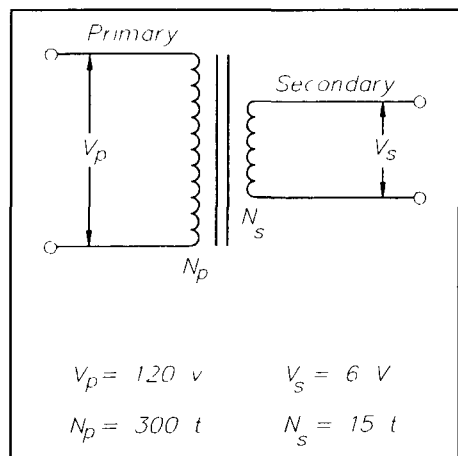

Figure 2 Example 1 Transformer

Example 2: An iron core transformer with a primary voltage of 240 volts has 250 turns in the primary and 50 turns in the secondary. Find the secondary voltage.

Solution:

$$\frac{V_P}{V_S} = \frac{N_P}{N_S}$$

Next, solve for V_S .

$$V_S = \frac{N_S}{N_P} V_P$$

$$V_S = \frac{50}{250} 240 \text{ volts}$$

$$V_S = 48 \text{ volts}$$

Example 3: A power transformer has a turns ratio of 1:4. If the secondary coil has 5000 turns and secondary voltage is 60 volts, find the voltage ratio, V_P , and N_P .

Solution:

$$VR = TR$$

$$VR = 1:4$$

$$\frac{V_P}{V_S} = VR = 1:4 = \frac{1}{4}$$

$$V_P = \frac{1}{4} V_S = \frac{60}{4} = 15 \text{ volts}$$

$$TR = \frac{N_P}{N_S} = \frac{1}{4}$$

$$N_P = \frac{1}{4} N_S = \frac{5000}{4} = 1250 \text{ turns}$$

Current Ratio

The current in the windings of a transformer is inversely proportional to the voltage in the windings. This relationship is expressed in Equation (13-5).

$$\frac{V_P}{V_S} = \frac{I_S}{I_P} \quad (13-5)$$

where

$$\begin{aligned} I_P &= \text{primary coil current} \\ I_S &= \text{secondary coil current} \end{aligned}$$

Since the voltage ratio is equal to the turns ratio, we can express the current ratio in terms of the turns ratio, as in Equation (13-6).

$$\frac{N_P}{N_S} = \frac{I_S}{I_P} \quad (13-6)$$

Example 1: When operated at 120 V in the primary of an iron core transformer, the current in the primary is 4 amps. Find the current in the secondary if the voltage is stepped up to 500 V.

Solution:

$$\frac{V_P}{V_S} = \frac{I_S}{I_P}$$

Next, we solve for I_S .

$$I_S = \frac{V_P}{V_S} I_P$$

$$I_S = \frac{120}{500} 4 \text{ amps}$$

$$I_S = 0.96 \text{ amps}$$

Example 2: A transformer with 480 turns on the primary and 60 turns on the secondary draws 0.6 amps from a 120 V line. Find I_S .

Solution:

$$\frac{N_P}{N_S} = \frac{I_S}{I_P}$$

Next, we solve for I_s .

$$I_s = \frac{N_p}{N_s} I_p$$

$$I_s = \frac{480}{60} 0.6 \text{ amps}$$

$$I_s = 4.8 \text{ amps}$$

The student should note from the previous examples that a transformer that "steps-up" voltage, "steps-down" the current proportionally.

Three-Phase Transformer Connections

So far, our discussion has dealt with the operation of single-phase transformers. Three-phase transformer operation is identical except that three single-phase windings are used. These windings may be connected in wye, delta, or any combination of the two.

Delta Connection

In the delta connection, all three phases are connected in series to form a closed loop (Figure 3).

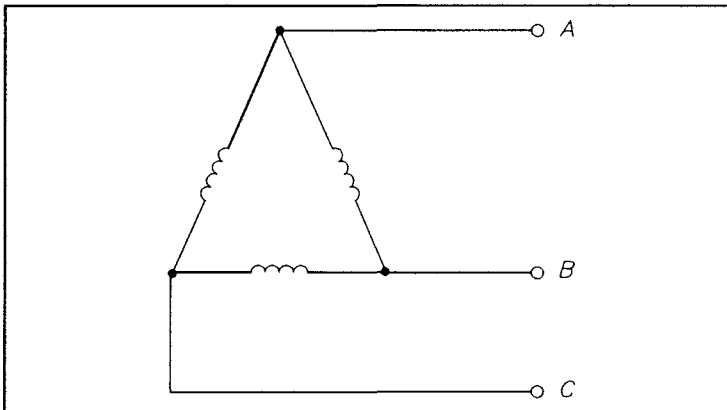

Figure 3 Delta Connection

Wye Connection

In the wye connection, three common ends of each phase are connected together at a common terminal (marked "N" for neutral), and the other three ends are connected to a three-phase line (Figure 4).

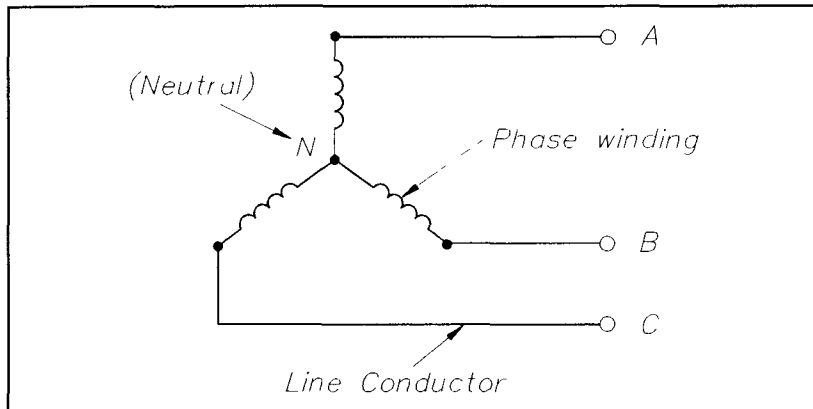

Figure 4 Wye Connection

Combinations of Delta and Wye Transformer Connections

A three-phase transformer may have three separate but identical single-phase (1 ϕ) transformers or a single 3 ϕ unit containing three-phase windings. The transformer windings may be connected to form a 3 ϕ bank in any of four different ways (Figure 5).

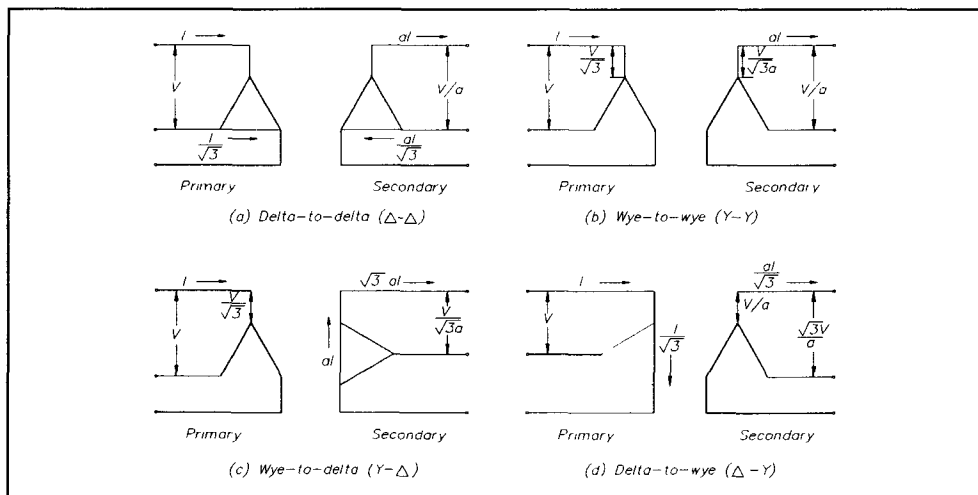

Figure 5 3 ϕ Transformer Connections

Figure 5 shows the voltages and currents in terms of applied line voltage (V) and line current (I), where the turns ratio (a) is equal to one. Voltage and current ratings of the individual transformers depend on the connections (Figure 5) and are indicated by Table 1 for convenience of calculations.

TABLE 1: Voltage and Current Ratings of Transformers

Transformer Connection (Primary to Secondary)	Primary				Secondary			
	Line		Phase		Line		Phase	
	Volt.	Current	Volt.	Current	Volt. *	Current	Volt.	Current
Δ - Δ	V	I	V	$\frac{I}{\sqrt{3}}$	$\frac{V}{a}$	aI	$\frac{V}{a}$	$\frac{aI}{\sqrt{3}}$
Y-Y	V	I	$\frac{V}{\sqrt{3}}$	I	$\frac{V}{a}$	aI	$\frac{V}{\sqrt{3}a}$	aI
Y- Δ	V	I	$\frac{V}{\sqrt{3}}$	I	$\frac{V}{\sqrt{3}a}$	$\sqrt{3}aI$	$\frac{V}{\sqrt{3}a}$	aI
Δ -Y	V	I	V	$\frac{I}{\sqrt{3}}$	$\frac{\sqrt{3}V}{a}$	$\frac{aI}{\sqrt{3}}$	$\frac{V}{a}$	$\frac{aI}{\sqrt{3}}$

*a = N_1/N_2 ; $\sqrt{3} = 1.73$

Example 1: If line voltage is 440 V to a 3 ϕ transformer bank, find the voltage across each primary winding for all four types of transformer connections.

Δ - Δ : primary voltage = V = 440 volts

Y-Y: primary voltage = $\frac{V}{\sqrt{3}} = \frac{440}{1.73} = 254.3$ volts

Y- Δ : primary voltage = $\frac{V}{\sqrt{3}} = \frac{440}{1.73} = 254.3$ volts

Δ -Y: primary voltage = V = 440 volts

Example 2: If line current is 10.4 A in a 3 ϕ transformer connection, find the primary phase current.

Δ - Δ : primary phase current = $\frac{I}{\sqrt{3}} = \frac{10.4}{1.73} = 6$ amps

Y-Y: primary phase current = I = 10.4 amps

Y- Δ : primary phase current = I = 10.4 amps

$$\Delta\text{-Y: primary phase current} = \frac{I}{\sqrt{3}} = \frac{10.4}{1.73} = 6 \text{ amps}$$

Example 3: Find the secondary line current and phase current for each type of transformer connection, if primary line current is 20 amps, and the turns ratio is 4:1.

$$\Delta\text{-}\Delta: \text{secondary line current} = 4(20) = 80 \text{ amps}$$

$$\text{secondary phase current} = \frac{aI}{\sqrt{3}} = \frac{4(20)}{1.73} = 46.2 \text{ amps}$$

$$\text{Y-Y: second line current} = aI = 4(20) = 80 \text{ amps}$$

$$\text{second phase current} = aI = 4(20) = 80 \text{ amps}$$

$$\text{Y-}\Delta: \text{secondary line current} = \sqrt{3} aI = (1.73)(4)(20) = 138.4 \text{ amps}$$

$$\text{secondary phase current} = aI = 4(20) = 80 \text{ amps}$$

$$\Delta\text{-Y: secondary line current} = \frac{aI}{\sqrt{3}} = \frac{4(20)}{1.73} = 46.2 \text{ amps}$$

$$\text{secondary phase current} = \frac{aI}{\sqrt{3}} = \frac{4(20)}{1.73} = 46.2 \text{ amps}$$

Transformer Losses and Efficiency

All transformers have copper and core losses. Copper loss is power lost in the primary and secondary windings of a transformer due to the ohmic resistance of the windings. Copper loss, in watts, can be found using Equation (13-7).

$$\text{Copper Loss} = I_p^2 R_p + I_s^2 R_s \quad (13-7)$$

where

I_p = primary current

I_s = secondary current

R_p = primary winding resistance

R_s = secondary winding resistance

Core losses are caused by two factors: hysteresis and eddy current losses. Hysteresis loss is that energy lost by reversing the magnetic field in the core as the magnetizing AC rises and falls and reverses direction. Eddy current loss is a result of induced currents circulating in the core.

The efficiency of a transformer can be calculated using Equations (13-8), (13-9), and (13-10).

$$\text{Efficiency} = \frac{\text{Power Output}}{\text{Power Input}} = \frac{P_s}{P_p} \times 100 \quad (13-8)$$

$$\text{Efficiency} = \frac{\text{Power Output}}{\text{Power Output} + \text{Copper Loss} + \text{Core Loss}} \times 100 \quad (13-9)$$

$$\text{Efficiency} = \frac{V_s I_s \times \text{PF}}{(V_s I_s \times \text{PF}) + \text{Copper Loss} + \text{Core Loss}} \times 100 \quad (13-10)$$

where

PF = power factor of the load

Example 1: A 5:1 step-down transformer has a full-load secondary current of 20 amps. A short circuit test for copper loss at full load gives a wattmeter reading of 100 W. If $R_p = 0.3\Omega$, find R_s and power loss in the secondary.

Solution:

$$\text{Copper Loss} = I_p^2 R_p + I_s^2 R_s = 100 \text{ W}$$

To find I_p :

$$\frac{N_p}{N_s} = \frac{I_s}{I_p}$$

$$I_p = \frac{N_s}{N_p} I_s = \frac{1}{5} 20 = 4 \text{ amps}$$

To find R_s :

$$I_s^2 R_s = 100 - I_p^2 R_p$$

$$R_s = \frac{100 - I_p^2 R_p}{I_s^2} = \frac{100 - 0.3(4)^2}{20^2} = 0.24$$

$$\text{Power loss in secondary} = I_s^2 R_s = (20)^2 (0.24) = 96 \text{ W}$$

Example 2: An open circuit test for core losses in a 10 kVA transformer [Example (1)] gives a reading of 70 W. If the PF of the load is 90%, find efficiency at full load.

Solution:

$$\text{Eff.} = \frac{V_s I_s \times \text{PF}}{(V_s I_s \times \text{PF}) + \text{Copper Loss} + \text{Core Loss}} \times 100$$

$$V_s I_s = \text{transformer rating} = 10 \text{ kVA} = 10,000 \text{ VA}$$

$$\text{PF} = 0.90; \text{Copper loss} = 100 \text{ W}; \text{Core loss} = 70 \text{ W}$$

$$\text{Eff} = \frac{10,000 (0.90)}{10,000 (0.90) + 100 + 70} \times 100 = \frac{9000}{9170} \times 100 = 98.2\%$$

Transformer Operation Under No-Load

If the secondary of a transformer is left open-circuited (Figure 6), primary current is very low and is called the *no-load current*. No-load current produces the magnetic flux and supplies the hysteresis and eddy current losses in the core. The no-load current (I_E) consists of two components: the magnetizing current (I_M) and the core loss (I_H). Magnetizing current lags applied voltage by 90° , while core loss is in phase with the applied voltage (Figure 6b). V_p and V_s are shown 180° out of phase. I_H is very small in comparison with I_M , and I_M is nearly equal to I_E . No-load current, I_E , is also referred to as exciting current.

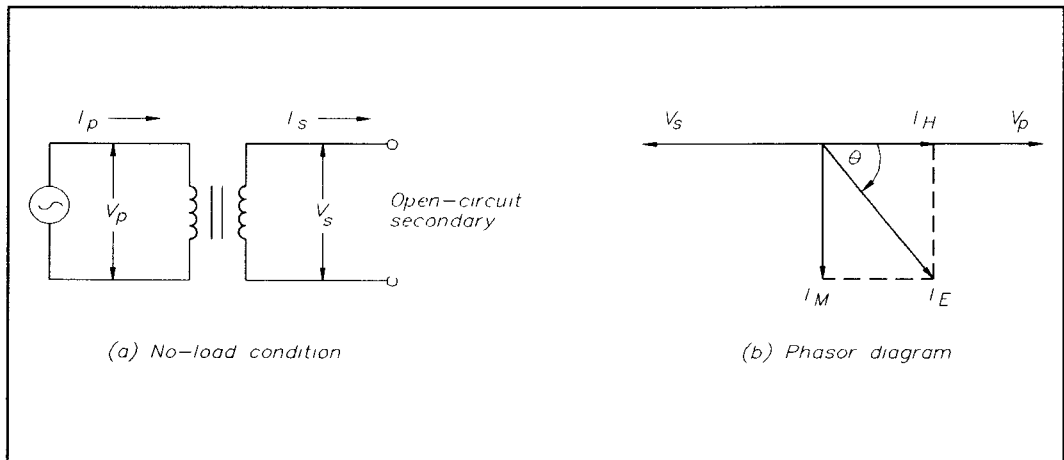

Figure 6 Open-Circuit Secondary

Example: When the secondary of a 120/440 V transformer is open, primary current is 0.2 amps at a PF of .3. The transformer is a 5 kVA transformer. Find: (a) I_p , (b) I_E , (c) I_H , and (d) I_m .

$$(a) \text{ Full load current} = \frac{\text{kVA Rating}}{V_p}$$

(b) I_p at no load is equal to I_E

$$I_E = 0.2 \text{ amp}$$

$$(c) I_H = I_E \cos \theta = I_E \times \text{PF}$$

$$= 0.2 (0.3)$$

$$I_H = 0.06 \text{ amps}$$

$$(d) I_M = I_E \sin \theta$$

$$\theta = \arccos 0.3 = 72.5^\circ$$

$$= (0.2) \sin 72.5^\circ = (0.2) (0.95)$$

$$I_M = 0.19 \text{ amps}$$

Coil Polarity

The symbol for a transformer gives no indication of the phase of the voltage across the secondary. The phase of that voltage depends on the direction of the windings around the core. In order to solve this problem, polarity dots are used to show the phase of primary and secondary signals. The voltages are either in phase (Figure 7a) or 180° out of phase with respect to primary voltage (Figure 7b).

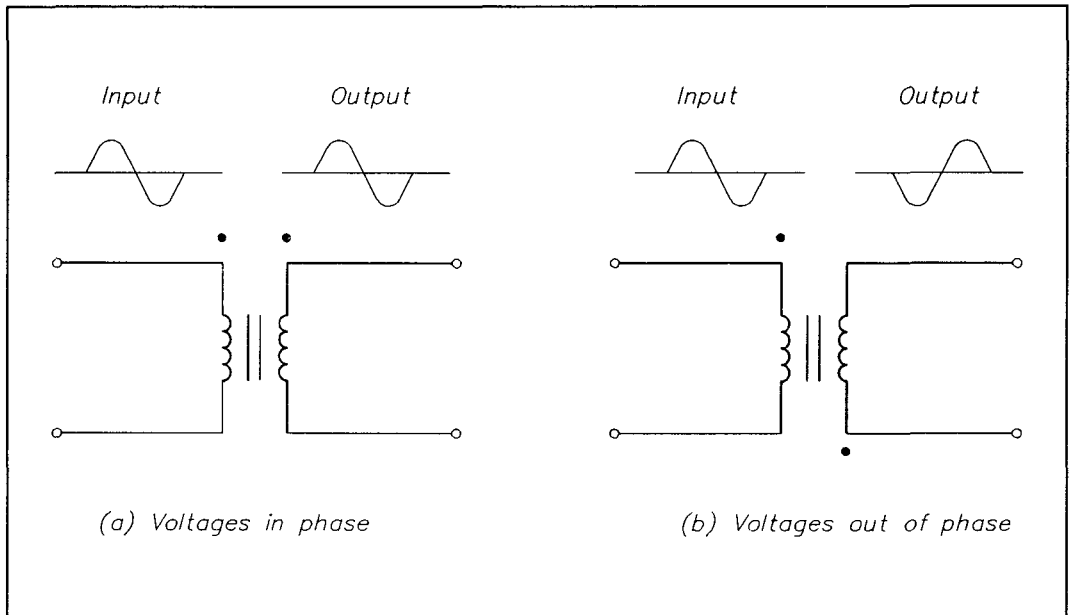

Figure 7 Polarity of Transformer Coils

Summary

The important information covered in this chapter is summarized below.

Transformer Theory Summary

- The induction of an EMF in a coil by magnetic flux lines generated in another coil is called mutual induction.
- The turns ratio is defined as the ratio of turns of wire in the primary winding to the number of turns of wire in the secondary winding.
- The ratio between the primary and secondary impedances is referred to as the impedance ratio.
- Efficiency of a transformer is the ratio of the power output to the power input.
- In a delta connection, all three phases are connected in series to form a closed loop.
- In a wye connection, three common ends of each phase are connected together at a common terminal, and the other three ends are connected to a three-phase line.
- In a Δ connected transformer:

$$V_L = V\phi$$

$$I_L = \sqrt{3} I\phi$$

- In a Y connected transformer:

$$I_L = \sqrt{3} V\phi$$

$$I_L = I\phi$$

TRANSFORMER TYPES

Transformers can be constructed so that they are designed to perform a specific function. A basic understanding of the various types of transformers is necessary to understand the role transformers play in today's nuclear facilities.

- EO 1.4** **STATE** the applications of each of the following types of transformers:
- a. **Distribution**
 - b. **Power**
 - c. **Control**
 - d. **Auto**
 - e. **Isolation**
 - f. **Instrument potential**
 - g. **Instrument current**
-

Types of Transformers

Transformers are constructed so that their characteristics match the application for which they are intended. The differences in construction may involve the size of the windings or the relationship between the primary and secondary windings. Transformer types are also designated by the function the transformer serves in a circuit, such as an isolation transformer.

Distribution Transformer

Distribution transformers are generally used in electrical power distribution and transmission systems. This class of transformer has the highest power, or volt-ampere ratings, and the highest continuous voltage rating. The power rating is normally determined by the type of cooling methods the transformer may use. Some commonly-used methods of cooling are by using oil or some other heat-conducting material. Ampere rating is increased in a distribution transformer by increasing the size of the primary and secondary windings; voltage ratings are increased by increasing the voltage rating of the insulation used in making the transformer.

Power Transformer

Power transformers are used in electronic circuits and come in many different types and applications. Electronics or power transformers are sometimes considered to be those with ratings of 300 volt-amperes and below. These transformers normally provide power to the power supply of an electronic device, such as in power amplifiers in audio receivers.

Control Transformer

Control transformers are generally used in electronic circuits that require constant voltage or constant current with a low power or volt-amp rating. Various filtering devices, such as capacitors, are used to minimize the variations in the output. This results in a more constant voltage or current.

Auto Transformer

The auto transformer is generally used in low power applications where a variable voltage is required. The auto transformer is a special type of power transformer. It consists of only one winding. By tapping or connecting at certain points along the winding, different voltages can be obtained (Figure 8).

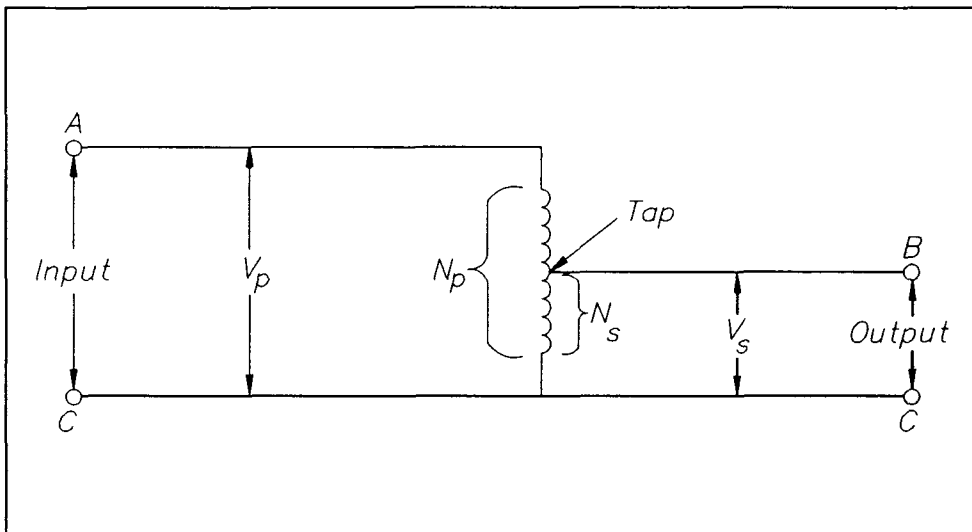

Figure 8 Auto Transformer Schematic

Isolation Transformer

Isolation transformers are normally low power transformers used to isolate noise from or to ground electronic circuits. Since a transformer cannot pass DC voltage from primary to secondary, any DC voltage (such as noise) cannot be passed, and the transformer acts to isolate this noise.

Instrument Potential Transformer

The instrument potential transformer (PT) steps down voltage of a circuit to a low value that can be effectively and safely used for operation of instruments such as ammeters, voltmeters, watt meters, and relays used for various protective purposes.

Instrument Current Transformer

The instrument current transformer (CT) steps down the current of a circuit to a lower value and is used in the same types of equipment as a potential transformer. This is done by constructing the secondary coil consisting of many turns of wire, around the primary coil, which contains only a few turns of wire. In this manner, measurements of high values of current can be obtained.

A current transformer should always be short-circuited when not connected to an external load. Because the magnetic circuit of a current transformer is designed for low magnetizing current when under load, this large increase in magnetizing current will build up a large flux in the magnetic circuit and cause the transformer to act as a step-up transformer, inducing an excessively high voltage in the secondary when under no load.

Summary

The important information covered in this chapter is summarized below.

Transformer Types Summary

- Distribution transformers are generally used in power distribution and transmission systems.
- Power transformers are used in electronic circuits and come in many different types and applications.
- Control transformers are generally used in circuits that require constant voltage or constant current with a low power or volt-amp rating.
- Auto transformers are generally used in low power applications where a variable voltage is required.
- Isolation transformers are normally low power transformers used to isolate noise from or to ground electronic circuits.
- Instrument potential and instrument current transformers are used for operation of instruments such as ammeters, voltmeters, watt meters, and relays used for various protective purposes.

**Department of Energy
Fundamentals Handbook**

**ELECTRICAL SCIENCE
Module 14
Test Instruments & Measuring Devices**

TABLE OF CONTENTS

LIST OF FIGURES	iii
LIST OF TABLES	iv
REFERENCES	v
OBJECTIVES	vi
METER MOVEMENTS	1
D'Arsonval Movement	1
Electrodynamometer Movement	2
Moving Iron Vane Movement	3
Summary	4
VOLTMETERS	5
Voltmeters	5
Summary	9
AMMETERS	10
Ammeters	10
Summary	14
OHM METERS	15
Ohm Meters	15
Summary	19
WATTMETERS	20
Wattmeters	20
Three-Phase Wattmeter	21
Summary	22

TABLE OF CONTENTS (Cont.)

OTHER ELECTRICAL MEASURING DEVICES	23
Ampere-Hour Meter	23
Power Factor Meter	24
Ground Detector	24
Synchroscope	26
Summary	27
TEST EQUIPMENT	28
Multimeter	28
Megger	28
Summary	30

LIST OF FIGURES

Figure 1	D'Arsonval Meter Movement	1
Figure 2	Electrodynamometer Movement	2
Figure 3	Moving Iron Vane Meter Movement	3
Figure 4	Simple DC Voltmeter	5
Figure 5	Measuring Circuit Voltage	8
Figure 6	Ammeter	10
Figure 7	Ammeter Accuracy	11
Figure 8	Ammeter with Shunt	13
Figure 9	Simple Ohm Meter Circuit	15
Figure 10	Ohm Meter Scale	19
Figure 11	Wattmeter Schematic	20
Figure 12	Wattmeters in Each Phase	21
Figure 13	Two Wattmeters to Measure 3ϕ Power	22
Figure 14	3ϕ Power Factor Meter Schematic	24
Figure 15	Simple Ohm Meter Ground Detector	25
Figure 16	Ground Detector Lamp Circuit	26
Figure 17	Simple Megger Circuit Diagram	29

LIST OF TABLES

NONE

REFERENCES

- Gussow, Milton, Schaum's Outline Series, Basic Electricity, McGraw-Hill.
- Academic Program for Nuclear Power Plant Personnel, Volume IV, Columbia, MD: General Physics Corporation, Library of Congress Card #A 326517, 1982.
- Academic Program for Nuclear Power Plant Personnel, Volume II, Columbia, MD: General Physics Corporation, Library of Congress Card #A 326517, 1982.
- Nasar and Unnewehr, Electromechanics and Electric Machines, John Wiley and Sons.
- Van Valkenburgh, Nooger, and Neville, Basic Electricity, Vol. 5, Hayden Book Company.
- Lister, Eugene C., Electric Circuits and Machines, 5th Edition, McGraw-Hill.
- Croft, Carr, Watt, and Summers, American Electricians Handbook, 10th Edition, McGraw-Hill.
- Mason, C. Russel, The Art and Science of Protective Relaying, John Wiley and Sons.
- Mileaf, Harry, Electricity One - Seven, Revised 2nd Edition, Hayden Book Company.
- Buban and Schmitt, Understanding Electricity and Electronics, 3rd Edition, McGraw-Hill.
- Kidwell, Walter, Electrical Instruments and Measurements, McGraw-Hill.

TERMINAL OBJECTIVE

- 1.0 Given a piece of test equipment or measuring device, **DESCRIBE** the use of that piece of electrical equipment, to include the meter movement, electrical parameter measurement, and connection of the device to a circuit.

ENABLING OBJECTIVES

- 1.1 **EXPLAIN** the following meter movements:
- D'Arsonval
 - Electrodynamometer
 - Moving iron vane
- 1.2 **STATE** the electrical parameters measured by each of the following in-place measuring devices:
- Voltmeter
 - Ammeter
 - Ohm meter
 - Wattmeter
 - Ampere-hour meter
 - Power factor meter
 - Ground detector
 - Synchroscope
- 1.3 **EXPLAIN** how the following electrical test equipment and measuring devices are connected to a circuit:
- Voltmeter
 - Ammeter
 - Ohm meter
 - Wattmeter
 - Ampere-hour meter
 - Power factor meter
 - Ground detector
 - Synchroscope
 - Megger
- 1.4 **STATE** the electrical parameters measured by each of the following test instruments:
- Multimeter
 - Megger

METER MOVEMENTS

There are three basic meter movements utilized in electrical meters: D'Arsonval, electro-dynamometer, and the moving iron vane. Some meter movements can be used for both AC or DC measurements, but in general, each meter movement is best suited for a particular type.

EO 1.1 **EXPLAIN** the following meter movements:

- a. **D'Arsonval**
- b. **Electrodynamometer**
- c. **Moving iron vane**

D'Arsonval Movement

The most commonly used sensing mechanism used in DC ammeters, voltmeters, and ohm meters is a current-sensing device called a D'Arsonval meter movement (Figure 1). The D'Arsonval movement is a DC moving coil-type movement in which an electromagnetic core is suspended between the poles of a permanent magnet.

The current measured is directed through the coils of the electromagnet so that the magnetic field produced by the current opposes the field of the permanent magnet and causes rotation of the core. The core is restrained by springs so that the needle will deflect or move in proportion to the current intensity. The more current applied to the core, the stronger the opposing field, and the larger the deflection, up to the limit of the current capacity of the coil. When the current is interrupted, the opposing field collapses, and the needle is returned to zero by the restraining springs. The limit of the current that can be applied to this type movement is usually less than one milliamper.

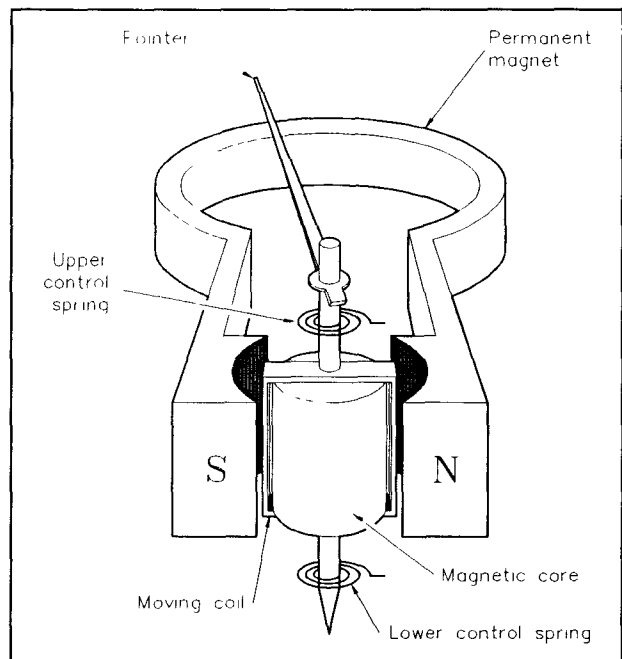

Figure 1 D'Arsonval Meter Movement

A common variation of the D'Arsonval movement is the Weston movement, which uses essentially the same principle built to a more rugged construction by employing jeweled supports for the core and employing a heavier winding in the electromagnet. Remember that the D'Arsonval movement is a DC device and can only measure DC current or AC current rectified to DC.

Electrodynamometer Movement

The electrodynamicometer movement (Figure 2) has the same basic operating principle as the D'Arsonval meter movement, except that the permanent magnet is replaced by fixed coils. The moving coil and pointer, which are attached to the coil, are suspended between and connected in series with the two field coils. The two field coils and moving coil are connected in series such that the same current flows through each coil.

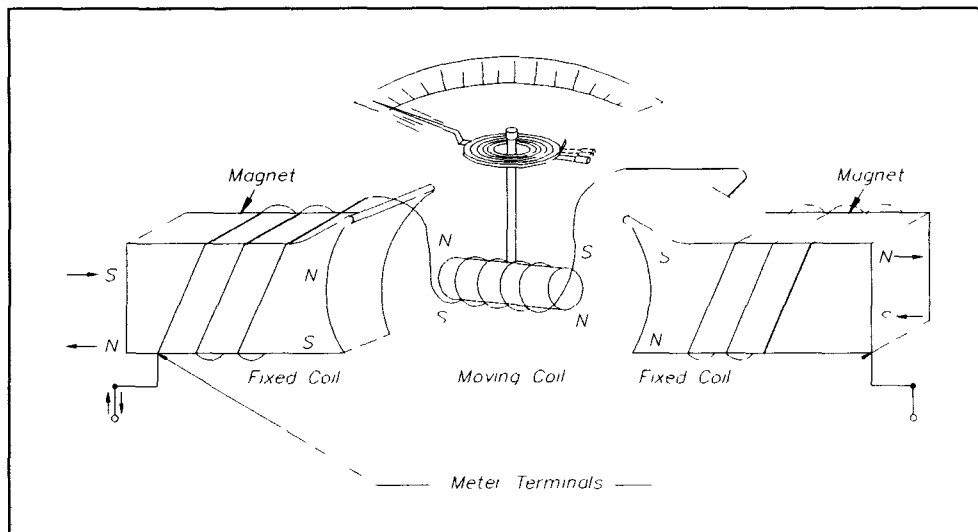

Figure 2 Electrodynamicometer Movement

Current flow through the three coils in either direction causes a magnetic field to be produced between the field coils. The same current flow through the moving coil causes it to act as a magnet exerting a force against the spring. If the current is reversed, the field polarity and the polarity of the moving coil reverse, and the force continues in the same direction. Due to this characteristic of the electrodynamicometer movement, it can be used in both AC and DC systems to measure current. Some voltmeters and ammeters use the electrodynamicometer. However, its most important use is in the wattmeter, which will be discussed later in this module.

Moving Iron Vane Movement

The moving iron vane movement (Figure 3) can be used to measure both AC current and voltage. By changing the meter scale calibration, the movement can be used to measure DC current and voltage. The moving iron vane meter operates on the principle of magnetic repulsion between like poles. The measured current flows through a field coil which produces a magnetic field proportional to the magnitude of current. Suspended in this field are two iron vanes attached to a pointer. The two iron vanes consist of one fixed and one moveable vane. The magnetic field produced by the current flow magnetizes the two iron vanes with the same polarity regardless of the direction of current through the coil. Since like poles repel one another, the moving iron vane pulls away from the fixed vane and moves the meter pointer. This motion exerts a force against a spring. The distance the moving iron vane will travel against the spring depends on the strength of the magnetic field. The strength of the magnetic field depends on the magnitude of current flow.

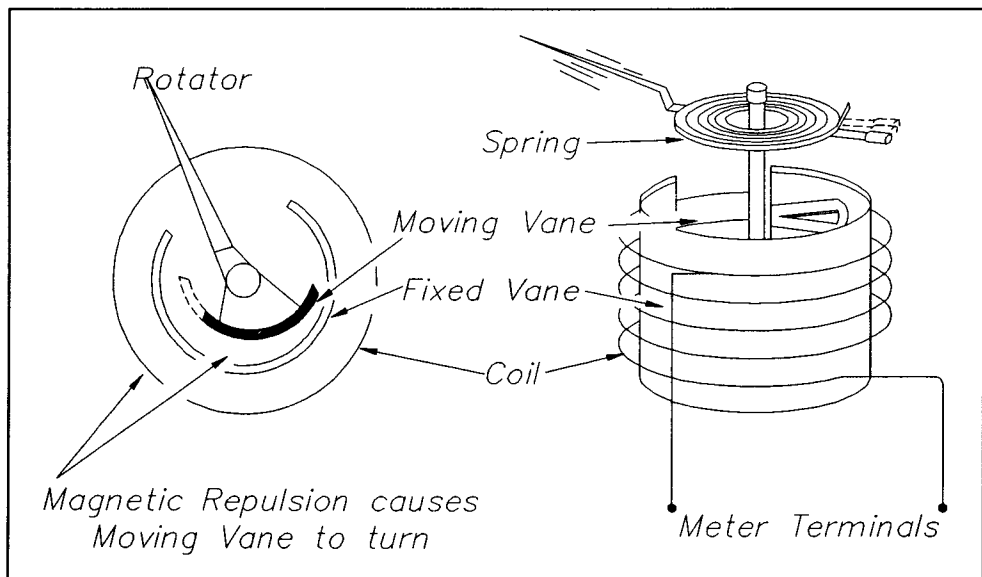

Figure 3 Moving Iron Vane Meter Movement

As stated previously, this type of meter movement may also be used to measure voltage. When this type of movement is used to measure voltage, the field coil consists of many turns of fine wire used to generate a strong magnetic field with only a small current flow.

Summary

Meter movements are summarized below.

Meter Movement Summary

- D'Arsonval - A DC moving coil movement where the moving coil is suspended between the poles of a permanent magnet restrained by helical springs, and the measured current flowing through the moving coil produces a torque on the attached pointer proportional to the current.
- Electrodynamicometer - The moving coil and attached pointer are suspended between and connected in series with the two stationary field coils so that the same current flows through each. A measured current flowing through the three coils in either direction causes a magnetic repulsion between the field coils and the moving coil. The magnetic repulsion exerts a force against the spring and provides a measurement of either DC or AC current.
- Moving iron vane - The moving iron vane meter operates on the principle of magnetic repulsion between like poles. The measured current flows through a field coil which induces a like magnetic field into a fixed and moving vane causing the moving vane to deflect a pointer in proportion to the current or voltage applied to the coil.

VOLTMETERS

Voltmeters are used extensively in industry where the surveillance of input and/or output voltages is vital for plant operation.

EO 1.2 STATE the electrical parameters measured by each of the following in-place measuring devices:

a. Voltmeter

EO 1.3 EXPLAIN how the following electrical test equipment and measuring devices are connected to a circuit:

a. Voltmeter

Voltmeter

A simple DC voltmeter can be constructed by placing a resistor (R_S), called a multiplier, in series with the ammeter meter movement, and marking the meter face to read voltage (Figure 4). Voltmeters are connected in parallel with the load (R_L) being measured.

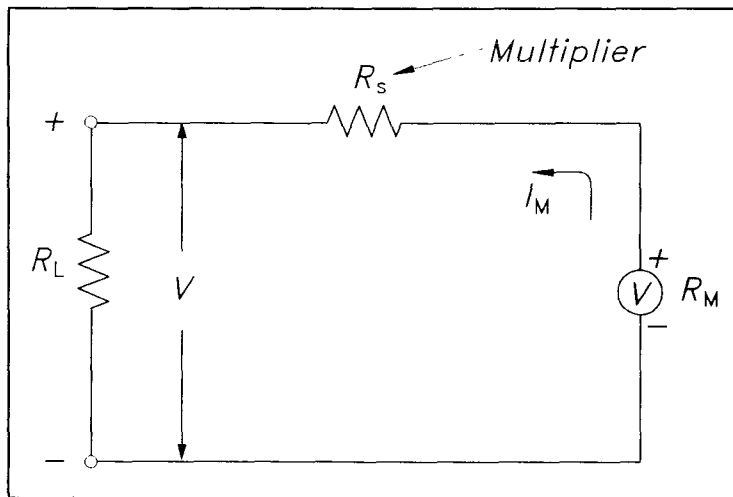

Figure 4 Simple DC Voltmeter

When constructing a voltmeter, the resistance of the multiplier must be determined to measure the desired voltage. Equation (14-1) is a mathematical representation of the voltmeter's multiplier resistance.

$$V = I_m R_s + I_m R_m$$

$$I_m R_s = V - I_m R_m$$

$$R_s = \frac{V}{I_m} - R_m \quad (14-1)$$

where

V = voltage range desired

I_m = meter current

R_m = meter resistance

R_s = multiplier resistance or series resistance

Example: A 2 mA meter movement with internal resistance of 25 ohms is to be constructed as a voltmeter.

What value must the series resistance be to measure full scale voltage of 100 volts?

Solution:

$$R_s = \frac{V}{I_m} - R_m$$

Since R_m is negligibly low, then:

$$R_s = \frac{V}{I_m}$$

$$= \frac{100}{2 \times 10^{-3}}$$

$$R_s = 50 \text{ k}\Omega$$

When a voltmeter is connected in a circuit, the voltmeter will draw current from that circuit. This current causes a voltage drop across the resistance of the meter, which is subtracted from the voltage being measured by the meter. This reduction in voltage is known as the loading effect and can have a serious effect on measurement accuracy, especially for low current circuits.

The accuracy of a voltmeter (K_v) is defined as the ratio of measured voltage when the meter is in the circuit (V_w) to the voltage measured with the meter out of the circuit. Equation (14-2) is a mathematical representation of the accuracy of a voltmeter, or true voltage (V_o).

$$K_v = \frac{V_w}{V_o} \quad (14-2)$$

Meter accuracy can also be determined by comparing the relationship between the input and circuit resistances using Ohm's Law as described below.

$$K_v = \frac{V_w}{V_o} \quad V_w = I_m R_m$$

$$= \frac{I_m R_m}{V_o} \quad I_m = \frac{V_o}{R_o + R_m}$$

$$= \frac{\left[\frac{V_o \cdot R_m}{R_o + R_m} \right]}{V_o}$$

$$K_v = \frac{R_m}{R_o + R_m}$$

where

- I_m = meter current
- V_o = true voltage
- R_o = circuit resistance
- R_m = input resistance of the voltmeter
- K_w = indicated voltage
- K_v = meter accuracy

Example: A voltmeter in the 100 volt range with a sensitivity of $40 \text{ K}\Omega/\text{V}$ is to measure the voltage across terminals ab (Figure 5).

- Find: 1. V_o
 2. V_w
 3. K_v

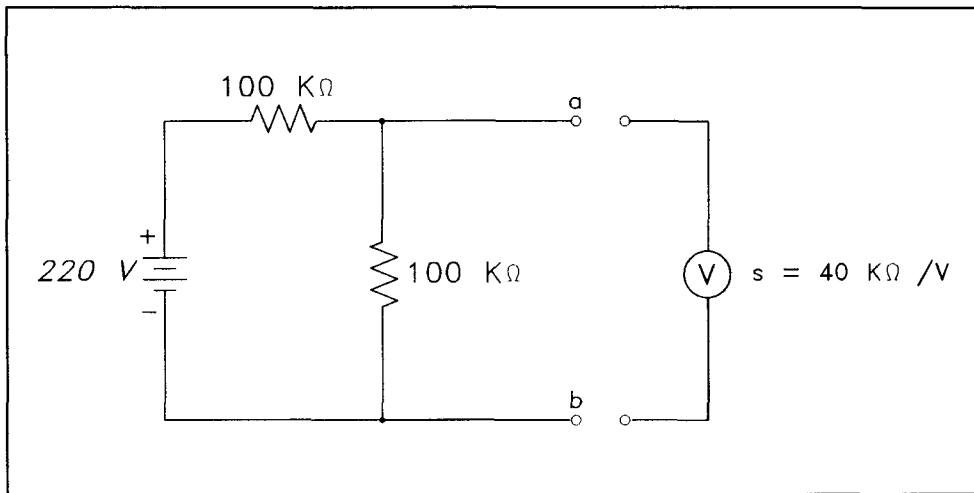

Figure 5 Measuring Circuit Voltage

Solution:

$$1. \quad V_o = \frac{100 \text{ K}\Omega}{100 \text{ K}\Omega + 100 \text{ K}\Omega} \times 220 \text{ V}$$

$$V_o = 110 \text{ volts}$$

$$2. \quad R_o = \frac{(100)(100)}{100 + 100} = 50\text{K}\Omega \quad R_{in} = SV = (40\text{K}\Omega/\text{V})(100\text{V}) = 4.4\text{M}\Omega$$

$$V_w = \frac{R_{in}}{R_o + R_{in}} V_o$$
$$= \left[\frac{4.4 \times 10^6}{50 \times 10^3 + 4.4 \times 10^6} \right] (110)$$
$$= (0.99)(110)$$

$$V_w = 108.9 \text{ volts}$$

$$3. \quad K_v = \frac{V_w}{V_o}$$
$$= \frac{108.9}{110}$$

$$K_v = 0.99 \text{ or } 99\%$$

Summary

Voltmeters are summarized below.

Voltmeter Summary

- Measures voltage
- Connected in parallel with the load being measured

AMMETERS

Measurement of current being supplied to or from a component is measured by an ammeter.

EO 1.2 STATE the electrical parameters measured by each of the following in-place measuring devices:

b. Ammeter

EO 1.3 EXPLAIN how the following electrical test equipment and measuring devices are connected to a circuit:

b. Ammeter

Ammeter

The ammeter measures electric current. It may be calibrated in amperes, milliamperes, or microamperes. In order to measure current, the ammeter must be placed in series with the circuit to be tested (Figure 6).

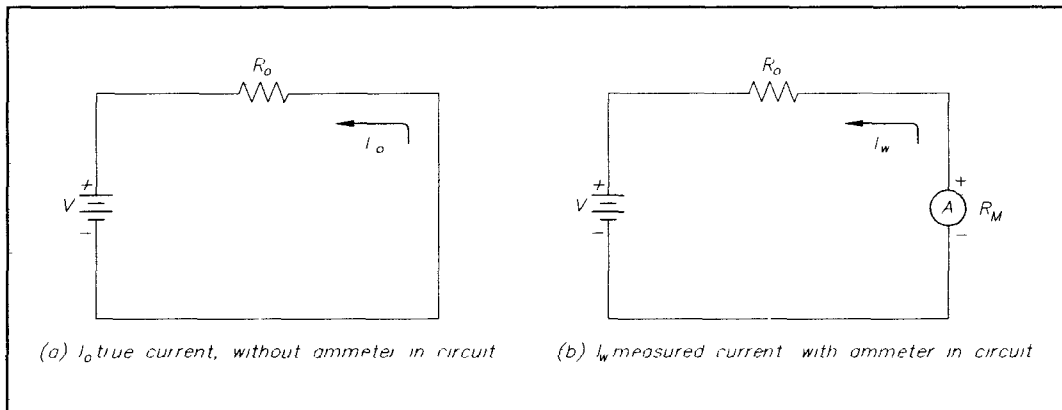

Figure 6 Ammeter

When an ammeter is placed in series with a circuit, it will increase the resistance of that circuit by an amount equal to the internal resistance of the meter R_m . Equation (14-3) is the mathematical representation of the current without the meter installed.

$$I_o = \frac{V}{R_o} \tag{14-3}$$

Equation (14-4) is the mathematical representation of the current with the meter installed in the circuit.

$$I_w = \frac{V}{R_o + R_m} \tag{14-4}$$

The accuracy of the ammeter K_A is the ratio of the current when the meter is in the circuit, I_w , to the current with the meter out of the circuit, I_o . Equation (14-5) is the mathematical representation for solving for the accuracy of the ammeter (K_A).

$$K_A = \frac{I_w}{I_o} \tag{14-5}$$

By substitution laws, Equation (14-6) is a mathematical representation of the accuracy using circuit resistance.

$$K_A = \left[\frac{V}{R_o + R_m} \right] \left[\frac{R_o}{V} \right] = \frac{R_o}{R_o + R_m} \tag{14-6}$$

The percent loading error is that percent of error due to loading effects that result from the added resistance of the meter. Equation (14-7) is a mathematical representation of the percent loading error.

$$\% \text{ loading error} = (1 - K_A)(100 \%) \tag{14-7}$$

A second error which occurs in an ammeter is calibration error. Calibration error is an error that occurs due to inaccurately marked meter faces. Typical values of calibration error in terms of full scale current are about 3 percent.

Example: An ammeter, with a 10 mA full scale deflection and an internal resistance of 400 Ω, is placed in a circuit with a 20 V power source and a 2 KΩ resistor (Figure 7).

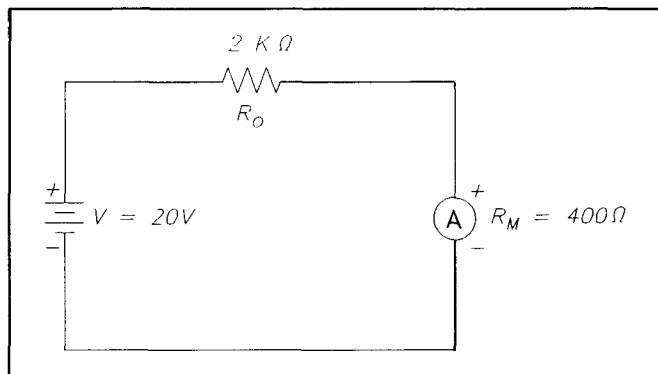

Figure 7 Ammeter Accuracy

- Find:
1. accuracy
 2. %loading error
 3. true current
 4. measured current

$$1. \quad K_A = \frac{R}{R_o + R_m}$$

$$K_A = \frac{2000}{2000 + 400}$$

$$K_A = 0.833 \text{ or } 83.3\%$$

$$2. \quad \% \text{ loading error} = (1 - K_A)(100\%)$$

$$\% \text{ loading error} = (1 - 0.833)(100\%)$$

$$\% \text{ loading error} = 16.7\%$$

$$3. \quad I_o = \frac{V}{R_o}$$

$$= \frac{20}{2000}$$

$$I_o = 0.01 \text{ A or } 10 \text{ mA}$$

$$4. \quad I_w = \frac{V}{R_o + R_m}$$

$$= \frac{20}{2000 + 400}$$

$$I_w = 8.33 \times 10^{-3} \text{ A or } 8.33 \text{ mA}$$

An ammeter with a full scale I_m can be shunted with a resistor R_{SH} in order to measure currents in excess of I_m (Figure 8). The reason for shunting an ammeter is to extend the range of the ammeter and, thereby, measure currents higher than the original full scale value.

By Kirchoff's current law,

$$I_{SH} = I_T - I_m$$

Since the voltage across the shunt must be equal to the voltage across the ammeter, shunt resistance is calculated as follows:

$$I_{SH} R_{SH} = I_m R_m$$

$$R_{SH} = \frac{I_m R_m}{I_{SH}}$$

$$R_{SH} = \frac{I_m R_m}{I_T - I_m}$$

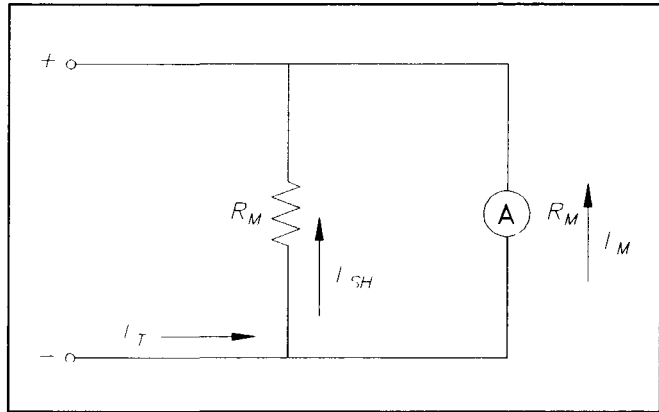

Figure 8 Ammeter with Shunt

Therefore, the input resistance of a shunted ammeter is related to the meter and shunt resistance. Equation (14-8) is a mathematical representation of this relationship.

NOTE: When computing accuracy for a shunted ammeter, use R_m^1 in place of R_m .

$$R_m^1 = \frac{R_m R_{SH}}{R_m + R_{SH}} \tag{14-8}$$

Equation (14-9) is a mathematical representation of the relationship between input voltage and current to the ammeter and the value of input resistance.

$$R_m^1 = \frac{V_{in}}{I_{in}} = \frac{I_m R_m}{I_T} \tag{14-9}$$

Example: An ammeter, with a 100 Ω meter resistance and a full scale deflection current of 4 mA, is to be shunted to measure currents from 1 to 20 mA.

- Find: 1. R_{SH}
 2. R_m^1

Solution:

$$\begin{aligned} 1. \quad R_{SH} &= \frac{I_m R_m}{I_T - I_m} \\ &= \frac{(4)(100)}{20 - 4} \end{aligned}$$

$$R_{SH} = 25 \Omega$$

$$\begin{aligned} 2. \quad R_m^1 &= \frac{I_m R_m}{I_T} \\ &= \frac{(4)(100)}{20} \end{aligned}$$

$$R_m^1 = 20 \Omega$$

Summary

Ammeters are summarized below.

Ammeter Summary

- Measure circuit current flow
- Connected in series with the circuit

OHM METERS

The resistance of a wire or a circuit is measured by an ohm meter. An ohm meter aids the troubleshooter in determining if a ground or a short exists in a circuit.

EO 1.2 STATE the electrical parameters measured by each of the following in-place measuring devices:

c. Ohm meter

EO 1.3 EXPLAIN how the following electrical test equipment and measuring devices are connected to a circuit:

c. Ohm meter

Ohm Meter

The ohm meter is an instrument used to determine resistance. A simple ohm meter (Figure 9) consists of a battery, a meter movement calibrated in ohms, and a variable resistor.

Ohm meters are connected to a component which is removed from the circuit as illustrated in Figure 9. The reason for removing the component is that measurement of current through the component determines the resistance. If the component remains in the circuit, and a parallel path exists in the circuit, the current will flow in the path of least resistance and give an erroneous reading.

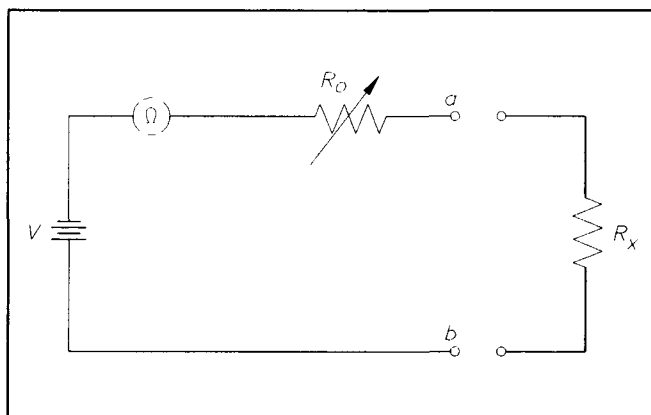

Figure 9 Simple Ohm Meter Circuit

R_o , in Figure 9, is an adjustable resistor whose purpose is to zero the ohm meter and correct for battery aging. It is also a current-limiting resistor which includes the meter resistance R_m . Zeroing the ohm meter is accomplished by shorting the ohm meter terminals ab and adjusting R_o to give full-scale deflection.

Equation (14-10) is the mathematical representation for determining full-scale deflection meter current.

$$I_m = \frac{V}{R_o} \quad (14-10)$$

When the unknown resistance R_x is connected across the ohm meter terminals, the current is measured by calculating the total series resistance and applying Equation (14-10). Equation (14-11) is the mathematical representation of this concept.

$$I = \frac{V}{R_o + R_x} \quad (14-11)$$

An easy way to determine ohm meter deflection is by use of a deflection factor (D). Deflection factor is the ratio of circuit current to meter current. Equation (14-12) is the mathematical representation of the deflection factor.

$$D = \frac{I}{I_m} = \frac{\frac{V}{R_o + R_x}}{\frac{V}{R_o}} = \frac{R_o}{R_o + R_x} \quad (14-12)$$

The current through the circuit can be determined by solving for I. Equation (14-13) is the mathematical representation of this relationship.

$$I = DI_m \quad (14-13)$$

To solve for R_x using Equations (14-10) through (14-13), the relationship between deflection factor and the meter resistance to the unknown resistance can be shown. Equation (14-14) is the mathematical representation of this relationship.

$$R_x = \frac{1 - D}{D} R_o \quad (14-14)$$

If half-scale deflection occurs, then $R_x = R_o$, so that the value of R_o is marked at mid-scale on the ohm meter face.

Example 1: An ohm meter has a meter movement with a $100 \mu\text{A}$ full-scale deflection. The open circuit voltage at terminals ab is 24 V . The ohm meter is zeroed and then an unknown resistance R_x is measured, which produces quarter-scale deflection. Find R_x .

Solution:

First find R_o .

$$R_o = \frac{V}{I_m}$$

$$= \frac{24}{1 \times 10^{-6}}$$

$$R_o = 2.4 \times 10^5 \Omega \text{ or } 240 \text{ K}\Omega$$

Then solve for R_x :

$$R_x = \frac{1 - D}{D} R_o$$

$$= \left[\frac{1 - \frac{1}{4}}{\frac{1}{4}} \right] (240)$$

$$= (3)(240)$$

$$R_x = 720 \text{ K}\Omega$$

Therefore, quarter scale deflection of this ohm meter face would read $720 \text{ K}\Omega$.

Example 2: An ohm meter with $R_o = 30 \Omega$, and full scale current $I_m = 300 \mu\text{A}$. Find I with: 1) 0Ω , 2) 5Ω , 3) 10Ω , 4) 15Ω , and 5) $1 \text{ M}\Omega$ resistors across the meter terminal.

Solution:

First, the deflection factor for each resistor must be found.

$$D = \frac{R_o}{R_o + R_x}$$

1. $R_x = 0 \Omega$
 $D = \frac{30}{30} = 1$
2. $R_x = 5 \Omega$
 $D = \frac{30}{30 + 5} = 0.86$
3. $R_x = 10 \Omega$
 $D = \frac{30}{30 + 10} = 0.75$
4. $R_x = 15 \Omega$
 $D = \frac{30}{30 + 15} = 0.67$
5. $R_x = 1 M\Omega$
 $D = \frac{30}{1 \times 10^6} = 1 \times 10^{-6} = 0.000001$ approximately 0

Then find I by using:

$$I = DI_m$$

1. $R_x = 0 \Omega$
 $I = (1)(300 \times 10^{-6}) = 300 \mu A$ full-scale deflection
2. $R_x = 5 \Omega$
 $I = (0.86)(300 \times 10^{-6}) = 258 \mu A$
3. $R_x = 10 \Omega$
 $I = (0.75)(300 \times 10^{-6}) = 225 \mu A$
4. $R_x = 15 \Omega$
 $I = (0.67)(300 \times 10^{-6}) = 201 \mu A$
5. $R_x = 1 M\Omega$
 $I = (0)(300 \times 10^{-6}) = 0 \mu A$ zero deflection

NOTE: As the resistance was increased from 0 to 5Ω , meter current decreased by $42\ \mu\text{A}$. Similarly, when resistance was increased from 5 to 10Ω , the current decreased by $33\ \mu\text{A}$. Thus, an ammeter scale used to measure resistance is nonlinear (Figure 10). The ohm meter scale is a reversal of the ammeter and voltmeter scales. In other words, the zero resistance ($R_x = 0$) is at the right end of the scale and infinite resistance ($R_x = 1\ \text{M}\Omega$) is at the left end of the scale.

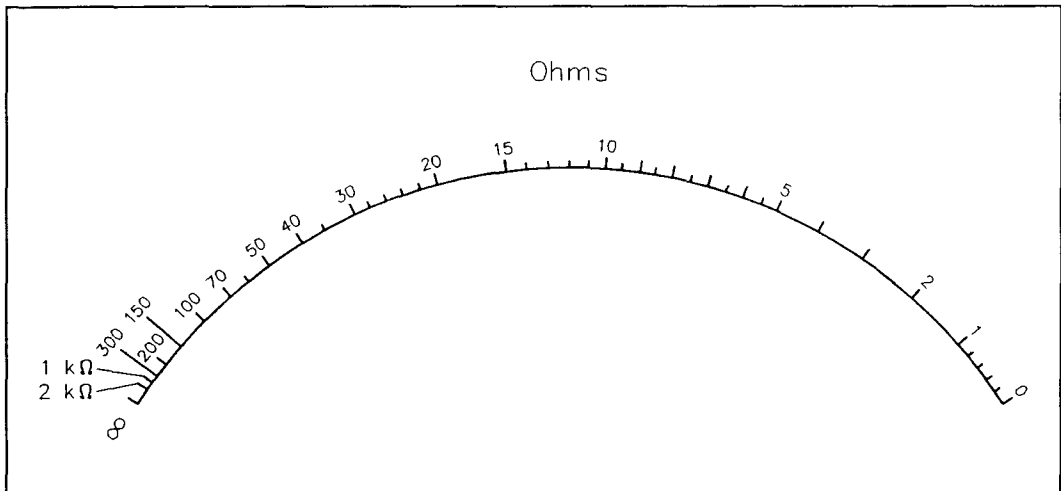

Figure 10 Ohm Meter Scale

Summary

Ohm meters are summarized below.

Ohm Meter Summary

- Measures circuit resistance
- Connected to a component removed from the circuit

WATTMETERS

Wattmeters are used to determine DC power or real AC power delivered to the load.

EO 1.2 STATE the electrical parameters measured by each of the following in-place measuring devices:

d. Wattmeter

EO 1.3 EXPLAIN how the following electrical test equipment and measuring devices are connected to a circuit:

d. Wattmeter

Wattmeter

The wattmeter is an instrument which measures DC power or true AC power. The wattmeter uses fixed coils to indicate current, while the movable coil indicates voltage (Figure 11). Coils L_{I1} and L_{I2} are the fixed coils in series with one another and serve as an ammeter. The two I terminals are connected in series with the load. The movable coil L_V , and its multiplier resistor R_S , are used as a voltmeter, with the V terminals connected in parallel with the load. The meter deflection is proportional to the VI, which is power.

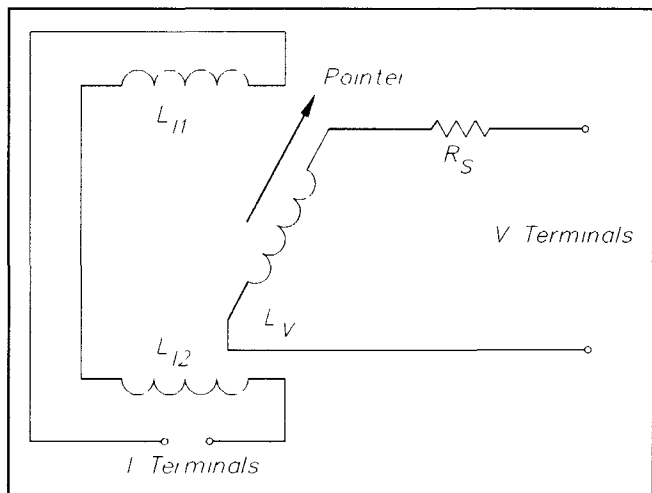

Figure 11 Wattmeter Schematic

Wattmeters are rated in terms of their maximum current, voltage, and power. All of these ratings must be observed to prevent damage to the meter.

Equation (14-15) is the mathematical representation of calculating power in a DC circuit.

$$P = VI \text{ or } P = I^2R \quad (14-15)$$

Equation (14-16) is the mathematical representation for calculating power in an AC circuit.

$$P = V_{Rms} I_{Rms} \cos \theta \text{ or } P = I^2 R \tag{14-16}$$

Three-Phase Wattmeter

Total power in a 3 ϕ circuit is the sum of the powers of the separate phases. The total power could be measured by placing a wattmeter in each phase (Figure 12); however, this method is not feasible since it is often impossible to break into the phases of a delta load. It also may not be feasible for the Y load, since the neutral point to which the wattmeters must be connected is not always accessible.

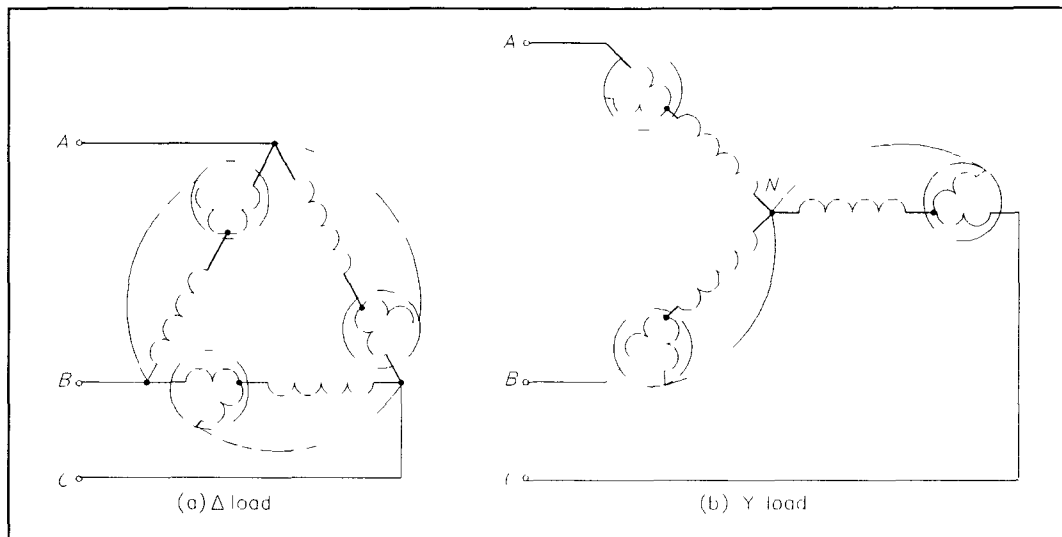

Figure 12 Wattmeters in Each Phase

Normally, only two wattmeters are used in making 3 ϕ power measurements (Figure 13).

In balanced 3 ϕ systems, with any power factor, total power is calculated by adding the A and B phase powers. Equation (14-17) is the mathematical representation for calculating total power (P_T).

$$P_T = W_A + W_B \tag{14-17}$$

where

W_A and W_B are the power readings in Phase A and Phase B

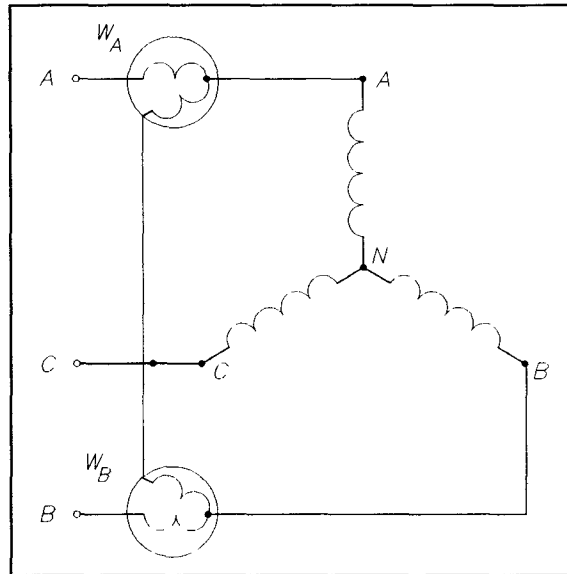

Figure 13 Two Wattmeters to Measure 3 ϕ Power

Summary

Wattmeters are summarized below.

Wattmeter Summary

- Measures real power delivered to the load
- Single-phase AC or DC - voltage component (movable coil) connected in parallel with the load and the current component (fixed coil) connected in series with the load
- Three-phase AC - summation of Phase A and B powers

OTHER ELECTRICAL MEASURING DEVICES

Other measuring devices are used to aid operators in determining the electric plant conditions at a facility, such as the ampere-hour meter, power factor meter, ground detector, and synchroscope.

- EO 1.2** **STATE** the electrical parameters measured by each of the following in-place measuring devices:
- e. **Ampere-hour meter**
 - f. **Power factor meter**
 - g. **Ground detector**
 - h. **Synchroscope**
- EO 1.3** **EXPLAIN** how the following electrical test equipment and measuring devices are connected to a circuit:
- e. **Ampere-hour meter**
 - f. **Power factor meter**
 - g. **Ground detector**
 - h. **Synchroscope**
-

Ampere-Hour Meter

The ampere-hour meter registers ampere-hours and is an integrating meter similar to the watt-hour meter used to measure electricity usage in a home. Typical ampere-hour meters are digital indicators similar to the odometer used in automobiles. The ampere-hour meter is a direct current meter that will register in either direction depending on the direction of current flow. For example, starting from a given reading, it will register the amount of discharge of a battery; when the battery is placed on charge, it will operate in the opposite direction, returning once again to its starting point. When this point is reached, the battery has received a charge equal to the discharge, and the charge is stopped. It is normally desired to give a battery a 10% overcharge. This is accomplished by designing the ampere-hour meter to run 10% slow in the charge direction. These meters are subject to inaccuracies and cannot record the internal losses of a battery. They attempt to follow the charge and discharge, but inherently do not indicate the correct state of charge. Similar to an ammeter, the ampere-hour meter is connected in series. Although the ampere-hour meters were used quite extensively in the past, they have been largely superseded by the voltage-time method of control.

Power Factor Meter

A power factor meter is a type of electrodynamicometer movement when it is made with two movable coils set at right angles to each other. The method of connection of this type of power factor meter, in a 3 ϕ circuit, is shown in Figure 14. The two stationary coils, S and S', are connected in series in Phase B. Coils M and M' are mounted on a common shaft, which is free to move without restraint or control springs. These coils are connected with their series resistors from Phase B to Phase A and from Phase B to Phase C. At a power factor of unity, one potential coil current leads and one lags the current in Phase B by 30°; thus, the coils are balanced in the position shown in Figure 14. A change in power factor will cause the current of one potential coil to become more in phase and the other potential coil to be more out of phase with the current in Phase B, so that the moving element and pointer take a new position of balance to show the new power factor.

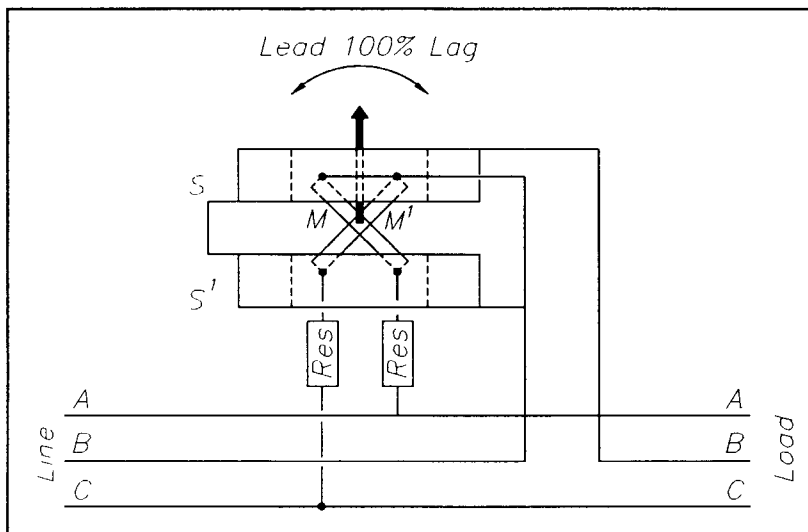

Figure 14 3 ϕ Power Factor Meter Schematic

Ground Detector

The ground detector is an instrument which is used to detect conductor insulation resistance to ground. An ohm meter, or a series of lights, can be used to detect the insulation strength of an ungrounded distribution system. Most power distribution systems in use today are of the grounded variety; however, some ungrounded systems still exist.

In the ohm meter method (Figure 15), a DC voltage is applied to the conductor. If a leakage path exists between the conductor insulator and ground, a current will flow through the ground to the ohm meter proportional to the insulation resistance of the conductor.

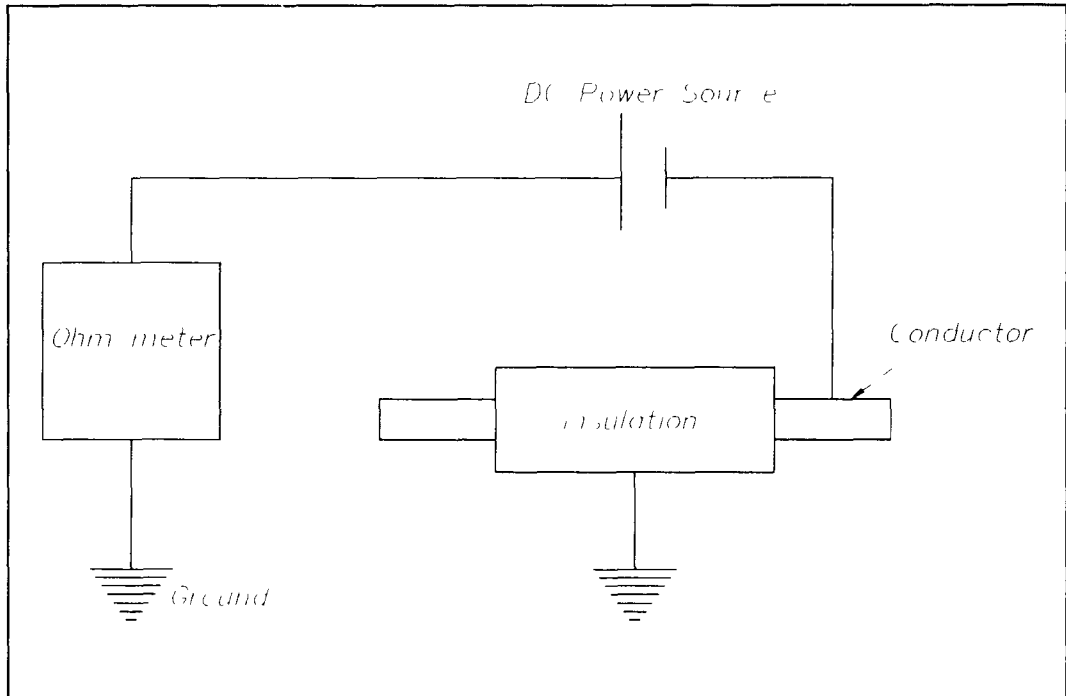

Figure 15 Simple Ohm Meter Ground Detector

In the ground detector lamp method (Figure 16), a set of three lamps connected through transformers to the system is used. To check for grounds, the switch is closed and the brilliance of the lamps is observed. If the lamps are equally bright, no ground exists and all the lamps receive the same voltage. If any one lamp is dark, and the other two lamps are brighter, the phase in which the darkened lamp is in is grounded. In this case, the primary winding of the transformer is shorted to ground and receives no voltage.

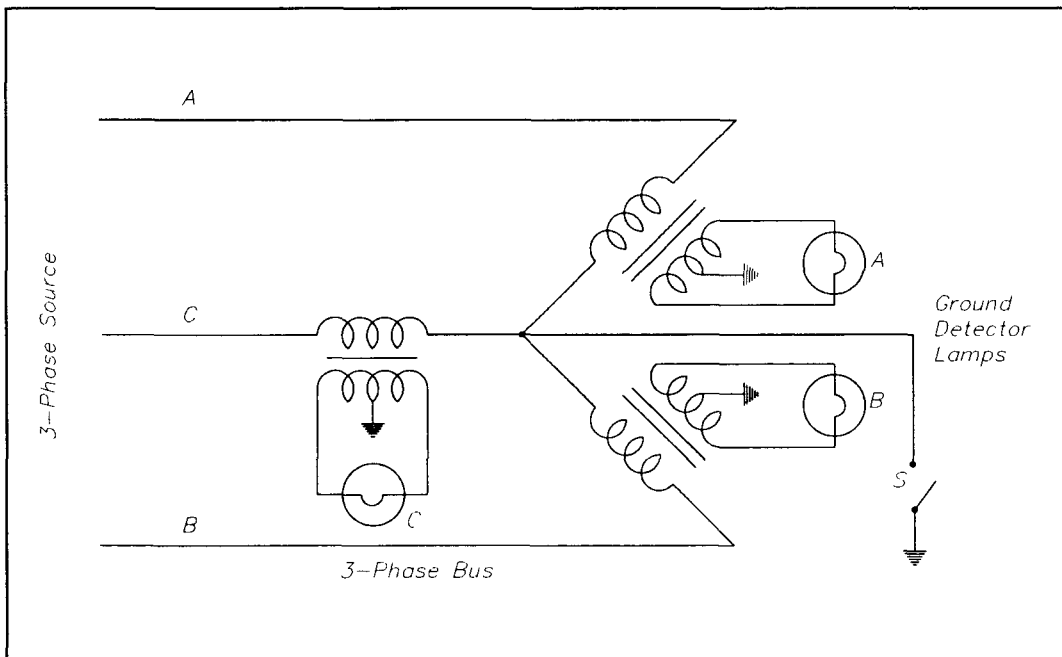

Figure 16 Ground Detector Lamp Circuit

Synchroscope

A synchroscope indicates when two AC generators are in the correct phase relation for connecting in parallel and shows whether the incoming generator is running faster or slower than the on-line generator. The synchroscope consists of a two-phase stator. The two stator windings are at right angles to one another, and by means of a phase-splitting network, the current in one phase leads the current of the other phase by 90° , thereby generating a rotating magnetic field. The stator windings are connected to the incoming generator, and a polarizing coil is connected to the running generator.

The rotating element is unrestrained and is free to rotate through 360° . It consists of two iron vanes mounted in opposite directions on a shaft, one at the top and one at the bottom, and magnetized by the polarizing coil.

If the frequencies of the incoming and running generators are different, the synchroscope will rotate at a speed corresponding to the difference. It is designed so that if incoming frequency is higher than running frequency, it will rotate in the clockwise direction; if incoming frequency is less than running frequency, it will rotate in the counterclockwise direction. When the synchroscope indicates 0° phase difference, the pointer is at the "12 o'clock" position and the two AC generators are in phase.

Summary

The important information contained in this chapter is summarized below.

Measuring Devices Summary

Ampere-hour Meter

- Measures current flow (either direction) through a given point
- Connected in series

Power Factor Meter

- Measures power factor between phases in a 3-phase circuit
- Connected in series with one phase

Ground Detector

- Measures conductor insulation
- Connected out of circuit to ground

Synchroscope

- Measures relationship between generator frequencies
- Connected by a two-phase stator at right angles

TEST EQUIPMENT

The multimeter can be used as an ammeter, an ohm meter, or a voltmeter. Meggers are used to measure insulation resistance.

EO 1.3 **EXPLAIN** how the following electrical test equipment and measuring devices are connected to a circuit:
i. **Megger**

EO 1.4 **STATE** the electrical parameters measured by each of the following test instruments:
a. **Multimeter**
b. **Megger**

Multimeter

The multimeter is a portable single instrument capable of measuring various electrical values including voltage, resistance, and current. The volt-ohm-milliammeter (VOM) is the most commonly used multimeter. The typical VOM has a meter movement with a full scale current of $50 \mu\text{A}$, or a sensitivity of $20 \text{ K}\Omega/\text{V}$, when used as a DC voltmeter. A single meter movement is used to measure current, AC and DC voltage, and resistance. Range switches are usually provided for scale selection (e.g., 0-1V, 0-10V, etc).

Megger

The megger is a portable instrument used to measure insulation resistance. The megger consists of a hand-driven DC generator and a direct reading ohm meter. A simplified circuit diagram of the instrument is shown in Figure 17.

The moving element of the ohm meter consists of two coils, A and B, which are rigidly mounted to a pivoted central shaft and are free to rotate over a C-shaped core (C on Figure 17). These coils are connected by means of flexible leads. The moving element may point in any meter position when the generator is not in operation.

As current provided by the hand-driven generator flows through Coil B, the coil will tend to set itself at right angles to the field of the permanent magnet. With the test terminals open, giving an infinite resistance, no current flows in Coil A. Thereby, Coil B will govern the motion of the rotating element, causing it to move to the extreme counter-clockwise position, which is marked as infinite resistance.

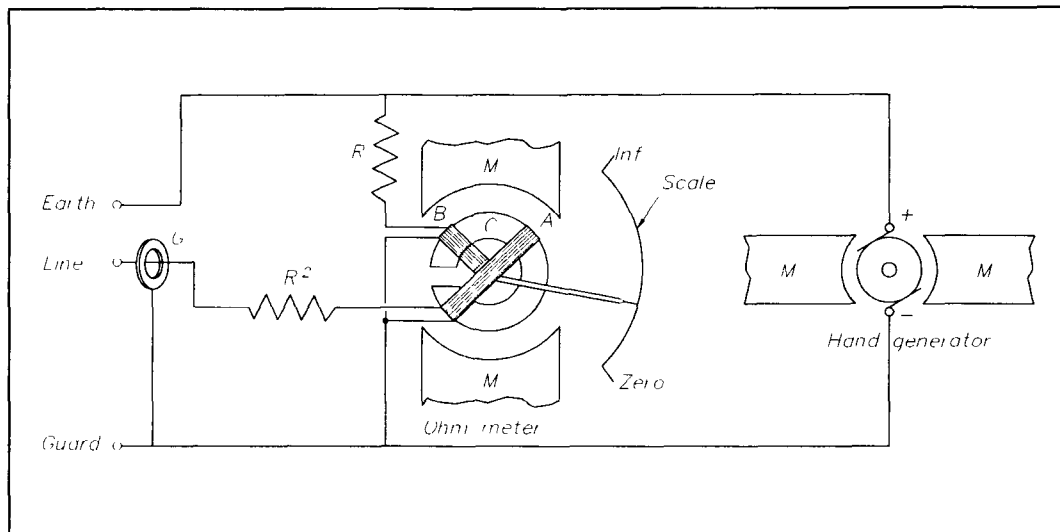

Figure 17 Simple Megger Circuit Diagram

Coil A is wound in a manner to produce a clockwise torque on the moving element. With the terminals marked "line" and "earth" shorted, giving a zero resistance, the current flow through the Coil A is sufficient to produce enough torque to overcome the torque of Coil B. The pointer then moves to the extreme clockwise position, which is marked as zero resistance. Resistance (R^1) will protect Coil A from excessive current flow in this condition.

When an unknown resistance is connected across the test terminals, line and earth, the opposing torques of Coils A and B balance each other so that the instrument pointer comes to rest at some point on the scale. The scale is calibrated such that the pointer directly indicates the value of resistance being measured.

Summary

Test equipment is summarized below.

Test Equipment Summary

- Multimeters measure current, voltage, and resistance.
- Meggers measure insulation resistance.
- Meggers are connected out of circuit.

**Department of Energy
Fundamentals Handbook**

**ELECTRICAL SCIENCE
Module 15
Electrical Distribution Systems**

TABLE OF CONTENTS

LIST OF FIGURES	iii
LIST OF TABLES	iv
REFERENCES	v
OBJECTIVES	vi
SYSTEM COMPONENTS AND PROTECTION DEVICES	1
Single (One-Line) Diagram	1
Commercial or Utility Power	1
Diesel Power	1
Failure-Free Power	3
Neutral Grounding	3
Voltage Class	3
Protective Relays	3
Overlapping Protective Zones	4
Fuses	5
Summary	6
CIRCUIT BREAKERS	7
Introduction	7
Low-Voltage Air Circuit Breakers	7
High-Voltage Circuit Breakers	11
Circuit Breaker Control	11
Summary	14
MOTOR CONTROLLERS	15
Motor Controllers	15
Manual Controllers	15
Magnetic Controller	16
Motor Controller Types and Operation	18
Summary	20

TABLE OF CONTENTS (Cont.)

WIRING SCHEMES AND GROUNDING 21

 Introduction 21

 Terminology 22

 Single-Phase Power 22

 Three-Phase Wiring Schemes 24

 3-Wire, Three-Phase Delta System 24

 4-Wire, Three-Phase Delta System 25

 4-Wire, Three-Phase Wye System 26

 Summary 27

LIST OF FIGURES

Figure 1	One-Line Distribution Diagram	2
Figure 2	Protective Relaying Zones	4
Figure 3	Types of Fuses	5
Figure 4	Molded Case Circuit Breaker	7
Figure 5	Cutaway View of Molded Case Circuit Breaker	8
Figure 6	Large Air Circuit Breaker	10
Figure 7	Simple Circuit Breaker Control Circuit - Breaker Open	12
Figure 8	Simple Circuit Breaker Control Circuit - Breaker Closed	13
Figure 9	Single Phase Manual Controller	16
Figure 10	Typical Three-Phase Magnetic Controller	17
Figure 11	Magnetic Contactor Assembly	18
Figure 12	LVP Controller	18
Figure 13	LVR Controller	19
Figure 14	LVRE Controller	19
Figure 15	Three-Phase to Single-Phase Connections	23
Figure 16	3-Wire Edison Scheme	24
Figure 17	3-Wire, Three-Phase Delta Scheme	25
Figure 18	4-Wire Delta System	26
Figure 19	4-Wire, Three Phase Wye System	27

LIST OF TABLES

NONE

REFERENCES

- Gussow, Milton, Schaum's Outline Series, Basic Electricity, McGraw-Hill.
- Academic Program for Nuclear Power Plant Personnel, Volume II, Columbia, MD: General Physics Corporation, Library of Congress Card #A 326517, 1982.
- Nasar and Unnewehr, Electromechanics and Electric Machines, John Wiley and Sons.
- Van Valkenburgh, Nooger, and Neville, Basic Electricity, Vol. 5, Hayden Book Company.
- Lister, Eugene C., Electric Circuits and Machines, 5th Edition, McGraw-Hill.
- Croft, Carr, Watt, and Summers, American Electricians Handbook, 10th Edition, McGraw-Hill.
- Mason, C. Russel, The Art and Science of Protective Relaying, John Wiley and Sons.
- Mileaf, Harry, Electricity One - Seven, Revised 2nd Edition, Hayden Book Company.
- Kidwell, Walter, Electrical Instruments and Measurements, McGraw-Hill.
- National Electrical Code, Batterymarch Park, Quincy, MA: National Fire Protection Association.

TERMINAL OBJECTIVE

- 1.0 Given the functional characteristics of an AC power source and the intended load, **DESCRIBE** the necessary components and the wiring scheme to provide a safe Electrical Distribution System.

ENABLING OBJECTIVES

- 1.1 **EXPLAIN** the following terms as they apply to Electrical Distribution Systems:
- a. Single (one-line) diagram
 - b. Commercial or utility power
 - c. Diesel power
 - d. Failure-free power
 - e. Neutral grounding
 - f. Voltage class
 - g. Protective relays
 - h. Overlapping protective zones
- 1.2 **DESCRIBE** the protection provided by each of the following:
- a. Fuses
 - b. Protective relays
- 1.3 **STATE** the purpose of circuit breakers.
- 1.4 Given a simple schematic of a circuit breaker control circuit, **DESCRIBE** the operation of that breaker during remote operation and automatic tripping.
- 1.5 **LIST** the three most widely-used protective features that may be incorporated into a circuit breaker control circuit.
- 1.6 **STATE** the function of motor controllers.
- 1.7 **STATE** three protective features (overloads) that may be incorporated into a motor controller.
- 1.8 Given a simplified drawing of a motor controller, **DESCRIBE** the operation of that motor controller.

ENABLING OBJECTIVES (Cont.)

- 1.9 **DEFINE** the following terms as they apply to wiring schemes used in power distribution systems:
- a. Ampacity
 - b. Bond
 - c. Conductor
 - d. Ground
 - e. Ground voltage
 - f. Leg
 - g. Neutral
 - h. Phase voltage
- 1.10 **DESCRIBE** the two methods of connecting single-phase loads to a three-phase power source.
- 1.11 **DESCRIBE** the purpose of the following power distribution schemes.
- a. 3-wire, single-phase Edison system
 - b. 3-wire, three-phase Delta system
 - c. 4-wire, three-phase Delta system
 - d. 4-wire, three-phase Wye system

Intentionally Left Blank

SYSTEM COMPONENTS AND PROTECTION DEVICES

Nuclear facilities rely on dependable electrical distribution systems to provide power to key vital equipment. Knowledge of the basic electrical power distribution system and its components will help the operator understand the importance of electrical power distribution systems.

- EO 1.1** **EXPLAIN** the following terms as they apply to Electrical Distribution Systems:
- a. **Single (one-line) diagram**
 - b. **Commercial or utility power**
 - c. **Diesel power**
 - d. **Failure-free power**
 - e. **Neutral grounding**
 - f. **Voltage class**
 - g. **Protective relays**
 - h. **Overlapping protective zones**
- EO 1.2** **DESCRIBE** the protection provided by each of the following:
- a. **Fuses**
 - b. **Protective relays**
-

Single (One-Line) Diagram

A *single*, or *one-line diagram* of a distribution system is a simple and easy-to-read diagram showing power supplies, loads, and major components in the distribution system (Figure 1).

Commercial or Utility Power

Commercial or utility power is electrical power that is provided by commercial generating systems to the facility.

Diesel Power

Diesel power is power generated by a diesel-driven generator. Diesel-driven generators are the most economical and practical source of "standby power."

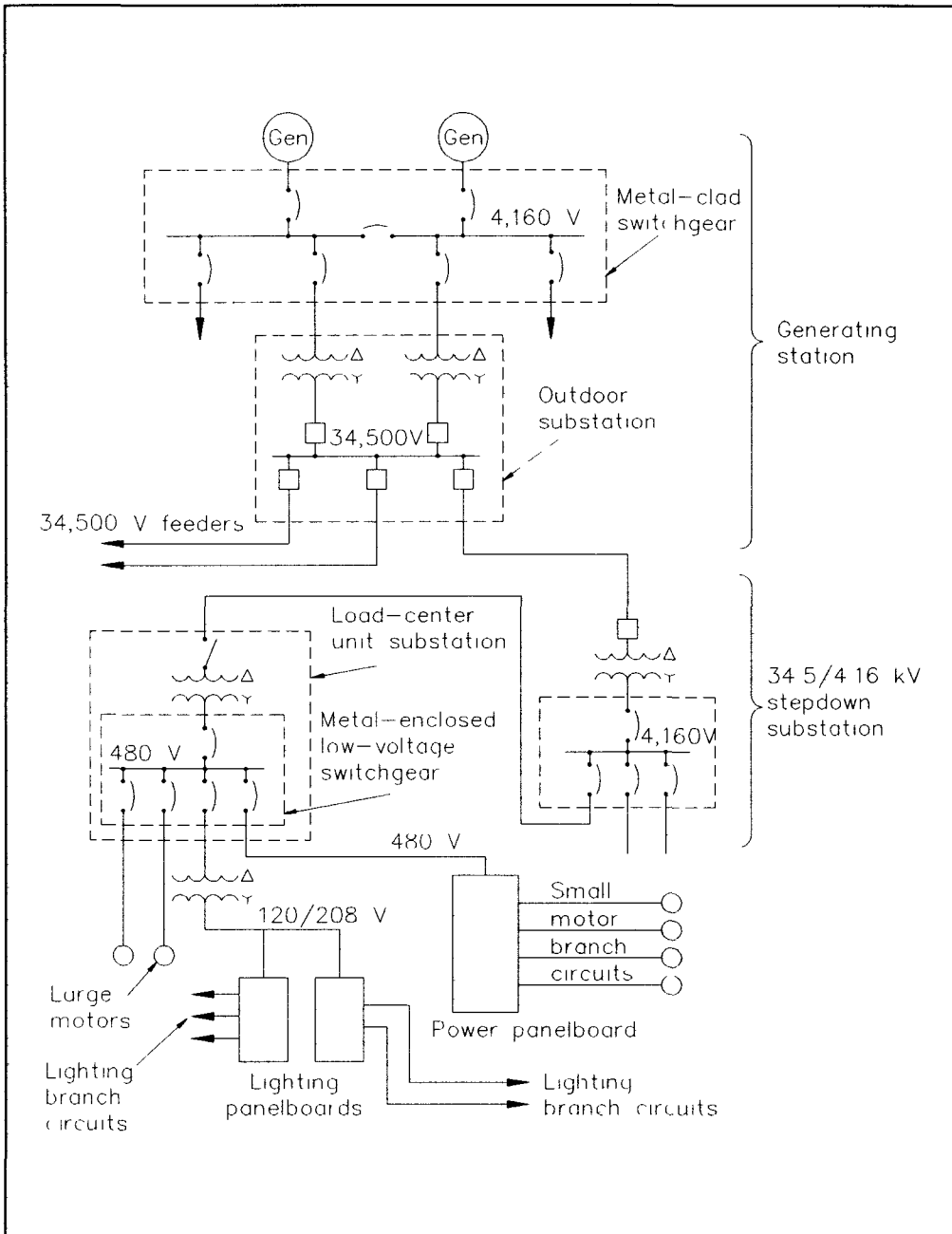

Figure 1 One-Line Distribution Diagram

Failure-Free Power

Failure-free power is accomplished by providing vital equipment with automatic switching between two or more power supplies so that interruption of power is minimized.

Neutral Grounding

Neutral grounding in electrical distribution systems helps prevent accidents to personnel and damage to property caused by: fire in case of lightning; a breakdown between primary and secondary windings of transformers; or accidental contact of high-voltage wires and low-voltage wires. If some point on the circuit is grounded (in this case neutral ground), lightning striking the wires will be conducted into the ground, and breakdown between the primary and secondary windings of a transformer will cause the primary transformer fuses to blow. Another advantage of neutral grounding is that it reduces the amount of insulation required for high-voltage transmission lines.

Voltage Class

Voltage in distribution systems is classified into three groups: high voltage, intermediate voltage, and low voltage. *High voltage* is voltage that is above 15,000 volts, *intermediate voltage* is voltage between 15,000 volts and 600 volts, and *low voltage* is voltage at 600 volts or less.

Protective Relays

Protective relays are designed to cause the prompt removal of any part of a power system that might cause damage or interfere with the effective and continuous operation of the rest of the system. Protective relays are aided in this task by circuit breakers that are capable of disconnecting faulty components or subsystems.

Protective relays can be used for types of protection other than short circuit or overcurrent. The relays can be designed to protect generating equipment and electrical circuits from any undesirable condition, such as undervoltage, underfrequency, or interlocking system lineups.

There are only two operating principles for protective relays: (1) electromagnetic attraction and (2) electromagnetic induction. Electromagnetic attraction relays operate by a plunger being drawn up into a solenoid or an armature that is attracted to the poles of an electromagnet. This type of relay can be actuated by either DC or AC systems. Electromagnetic induction relays operate on the induction motor principle whereby torque is developed by induction in a rotor. This type of relay can be used only in AC circuits.

Overlapping Protective Zones

A separate zone of protection is provided around each system element (Figure 2). Any failure that may occur within a given zone will cause the tripping or opening of all circuit breakers within that zone. For failures that occur within a region where two protective zones overlap, more breakers will be tripped than are necessary to disconnect the faulty component; however, if there were no overlap of protective zones, a fault in a region between the two zones would result in no protective action at all. Therefore, it is desirable for protective zone overlap to ensure the maximum system protection.

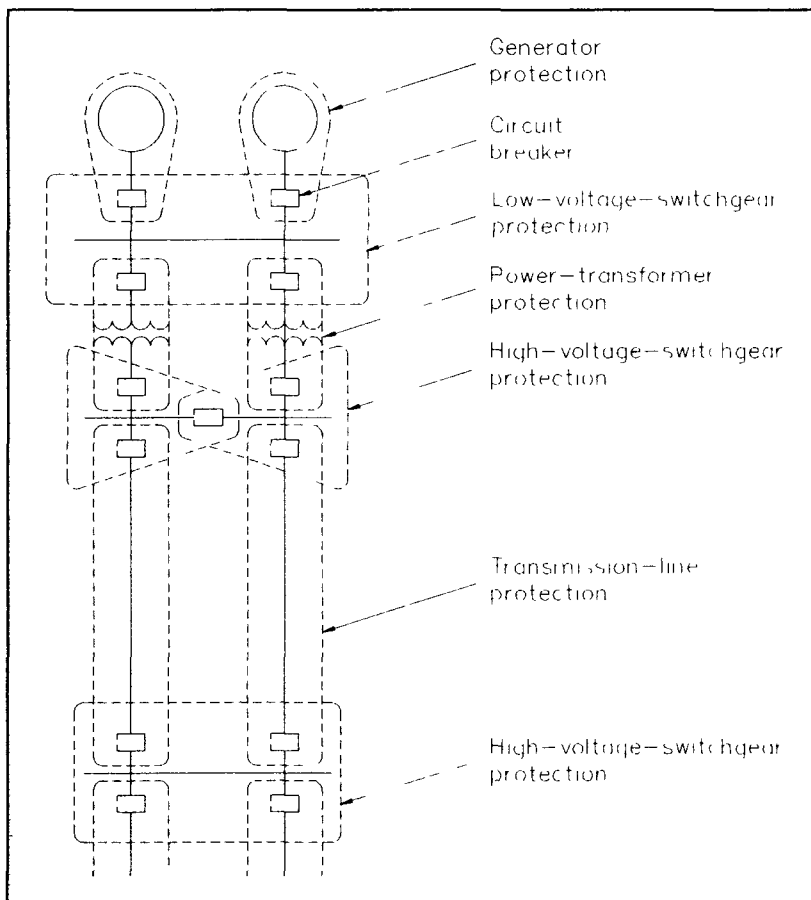

Figure 2 Protective Relaying Zones

Fuses

A fuse is a device that protects a circuit from an overcurrent condition only. It has a fusible link directly heated and destroyed by the current passing through it. A fuse contains a current-carrying element sized so that the heat generated by the flow of normal current through it does not cause it to melt the element; however, when an overcurrent or short-circuit current flows through the fuse, the fusible link will melt and open the circuit. There are several types of fuses in use (Figure 3).



Figure 3 Types of Fuses

The plug fuse is a fuse that consists of a zinc or alloy strip, a fusible element enclosed in porcelain or pyrex housing, and a screw base. This type of fuse is normally used on circuits rated at 125 V or less to ground and has a maximum continuous current-carrying capacity of 30 amps.

The cartridge fuse is constructed with a zinc or alloy fusible element enclosed in a cylindrical fiber tube with the element ends attached to a metallic contact piece at the ends of the tube. This type of fuse is normally used on circuits rated at either 250 volts or 600 volts and has a maximum continuous current-carrying capacity of 600 amps.

Summary

The important information contained in this chapter is summarized below.

System Components and Protection Devices Summary

- Single (one-line) diagram - simple and easy to read diagram showing power supplies, loads, and major components in the distribution system
- Commercial or utility power - electric power supplied to the facility
- Diesel power - economical/practical source of standby power
- Failure-free power - power supplied to vital equipment with automatic switching so that interruption of power is minimized
- Neutral grounding - helps prevent accidents to personnel and damage to property by fire
- Voltage class - high voltage $> 15,000$ volts, intermediate voltage is 600-15,000 volts, low voltage ≤ 600 volts
- Protective relays - cause prompt removal of any part of a power system that suffers a short circuit
- Overlapping protective zones - created around each element of the power system to prevent element failure from interrupting the whole system operation
- Breakers - disconnect component from the power system
- Fuse - protects component from overcurrent

CIRCUIT BREAKERS

A circuit breaker is a device that is used to completely disconnect a circuit when any abnormal condition exists. The circuit breaker can be designed to actuate under any undesirable condition.

- EO 1.3** **STATE** the purpose of circuit breakers.
- EO 1.4** **Given** a simple schematic of a circuit breaker control circuit, **DESCRIBE** the operation of that breaker during remote operation and automatic tripping.
- EO 1.5** **LIST** the three most widely-used protective features that may be incorporated into a circuit breaker control circuit.
-

Introduction

The purpose of a circuit breaker is to break the circuit and stop the current flow when the current exceeds a predetermined value without causing damage to the circuit or the circuit breaker. Circuit breakers are commonly used in place of fuses and sometimes eliminate the need for a switch. A circuit breaker differs from a fuse in that it "trips" to break the circuit and may be reset, while a fuse melts and must be replaced. Air circuit breakers (ACBs) are breakers where the interruption of the breaker contacts takes place in an air environment. Oil circuit breakers (OCBs) use oil to quench the arc when the breaker contacts open.

Low-Voltage Air Circuit Breakers

A low-voltage circuit breaker is one which is suited for circuits rated at 600 volts or lower. One of the most commonly used low-voltage air circuit breakers is the molded case circuit breaker (Figure 4).

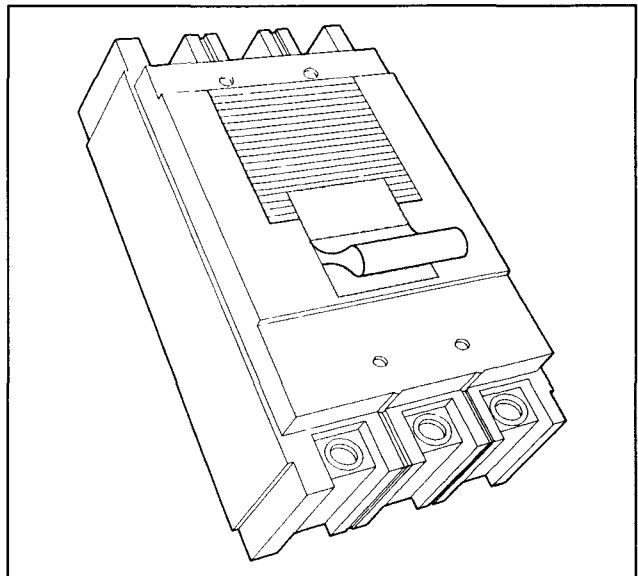

Figure 4 Molded Case Circuit Breaker

A cutaway view of the molded case circuit breaker is shown in Figure 5.

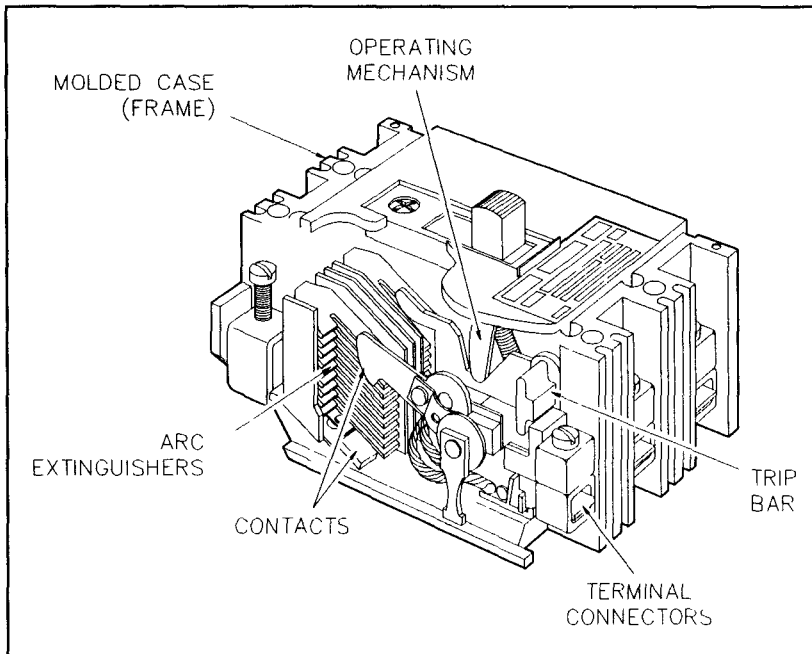

Figure 5 Cutaway View of Molded Case Circuit Breaker

A circuit can be connected or disconnected using a circuit breaker by manually moving the operating handle to the ON or OFF position. All breakers, with the exception of very small ones, have a linkage between the operating handle and contacts that allows a quick make (quick break contact action) regardless of how fast the operating handle is moved. The handle is also designed so that it cannot be held shut on a short circuit or overload condition. If the circuit breaker opens under one of these conditions, the handle will go to the trip-free position. The trip-free position is midway between the ON and OFF positions and cannot be re-shut until the handle is pushed to the OFF position and reset.

A circuit breaker will automatically trip when the current through it exceeds a pre-determined value. In lower current ratings, automatic tripping of the circuit breaker is accomplished by use of thermal tripping devices. Thermal trip elements consist of a bimetallic element that can be calibrated so that the heat from normal current through it does not cause it to deflect. An abnormally high current, which could be caused by a short circuit or overload condition, will cause the element to deflect and trip the linkage that holds the circuit breaker shut. The circuit breaker will then be opened by spring action. This bimetallic element, which is responsive to the heat produced by current flowing through it, has an inverse-time characteristic. If an extremely high current is developed, the circuit breaker will be tripped very rapidly.

For moderate overload currents, it will operate more slowly. Molded case breakers with much larger current ratings also have a magnetic trip element to supplement the thermal trip element. The magnetic unit utilizes the magnetic force that surrounds the conductor to operate the circuit breaker tripping linkage.

When the separable contacts of an air circuit breaker are opened, an arc develops between the two contacts. Different manufacturers use many designs and arrangements of contacts and their surrounding chambers. The most common design places the moving contacts inside of an arc chute. The construction of this arc chute allows the arc formed as the contacts open to draw out into the arc chute. When the arc is drawn into the arc chute, it is divided into small segments and quenched. This action extinguishes the arc rapidly, which minimizes the chance of a fire and also minimizes damage to the breaker contacts.

Molded case circuit breakers come in a wide range of sizes and current ratings. There are six frame sizes available: 100, 225, 400, 600, 800, and 2,000 amps. The size, contact rating, and current interrupting ratings are the same for all circuit breakers of a given frame size. The continuous current rating of a breaker is governed by the trip element rating. The range of voltage available is from 120 to 600 volts, and interrupting capacity ranges as high as 100,000 amps.

Much larger air circuit breakers are used in large commercial and industrial distribution systems. These circuit breakers are available in much higher continuous current and interrupting ratings than the molded case circuit breaker. Breakers of this type have current ratings as high as 4,000 amps, and interrupting ratings as high as 150,000 amps.

Most large air circuit breakers use a closing device, known as a "stored energy mechanism," for fast, positive closing action. Energy is stored by compressing large powerful coil springs that are attached to the contact assembly of a circuit breaker. Once these springs are compressed, the latch may be operated to release the springs, and spring pressure will shut the circuit breaker. Circuit breaker closing springs may be compressed manually or by means of a small electric motor. This type of circuit breaker can be classified as either a manually- or electrically-operated circuit breaker.

When a large air circuit breaker is closed, the operating mechanism is latched. As the circuit breaker is closed, a set of tripping springs, or coils, are compressed, and the circuit breaker may then be tripped by means of a trip latch. The trip latch mechanism may be operated either manually or remotely by means of a solenoid trip coil.

As previously stated, circuit breakers may be operated either manually or electrically. Electrically-operated circuit breakers are used when circuit breakers are to be operated at frequent intervals or when remote operation is required.

When the electrically-operated stored energy circuit breaker is tripped, the spring is recharged by the spring charging motor so that the breaker is ready for the next closing operation. The manually-operated circuit breaker closing springs are normally compressed by a hand crank just prior to operation of the breaker. Figure 6 shows a large air circuit breaker which is classified as a manually-operated stored energy circuit breaker. The closing springs are compressed by pulling downward on the large operating handle on the front of the breaker. Closing this circuit breaker is accomplished manually by depressing the small closing lever. Tripping this circuit breaker is done by means of the tripping lever, located at the bottom front of the breaker.

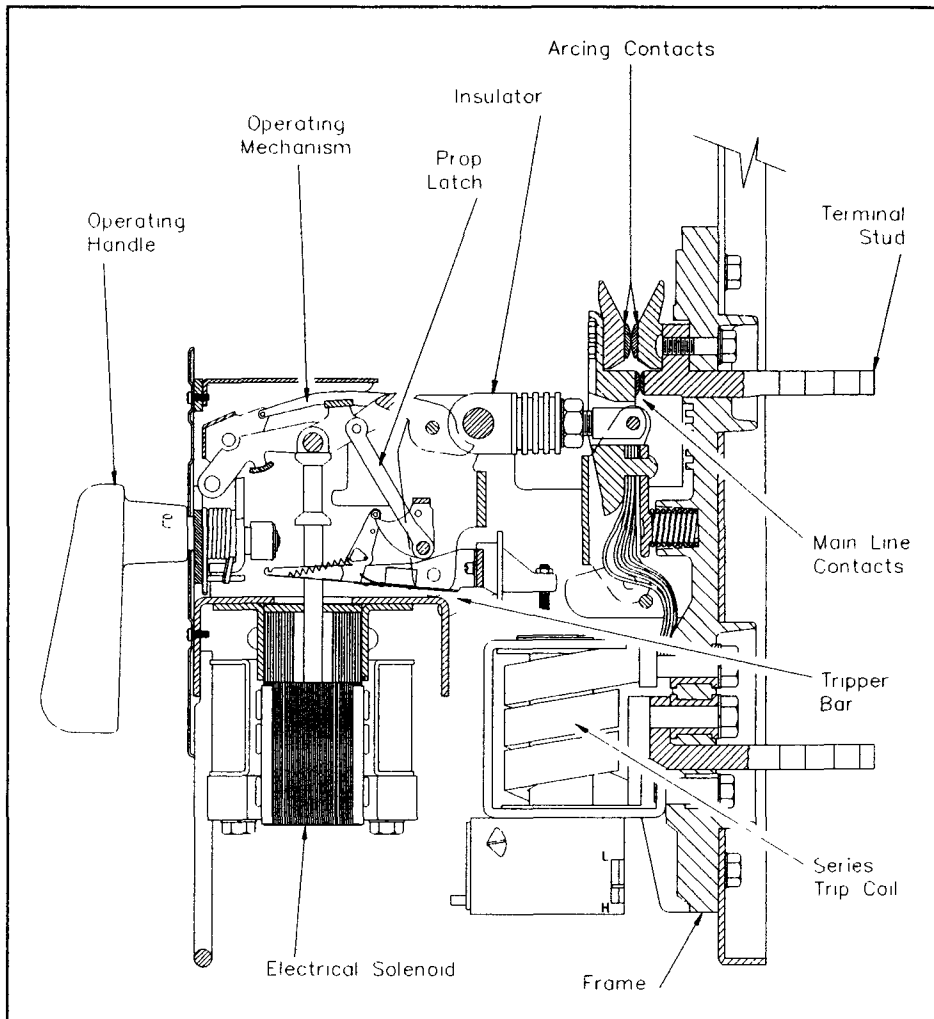

Figure 6 Large Air Circuit Breaker

High-Voltage Circuit Breakers

High-voltage circuit breakers (including breakers rated at intermediate voltage) are used for service on circuits with voltage ratings higher than 600 volts. Standard voltage ratings for these circuit breakers are from 4,160 to 765,000 volts and three-phase interrupting ratings of 50,000 to 50,000,000 kVA.

In the early stages of electrical system development, the major portion of high-voltage circuit breakers were oil circuit breakers. However, magnetic and compressed-air type air circuit breakers have been developed and are in use today.

The magnetic air circuit breaker is rated up to 750,000 kVA at 13,800 volts. This type of circuit breaker interrupts in air between two separable contacts with the aid of magnetic blowout coils. As the current-carrying contacts separate during a fault condition, the arc is drawn out horizontally and transferred to a set of arcing contacts. Simultaneously, the blowout coil provides a magnetic field to draw the arc upward into the arc chutes. The arc, aided by the blowout coil magnetic field and thermal effects, accelerates upward into the arc chute, where it is elongated and divided into many small segments.

The construction of this type of circuit breaker is similar to that of a large air circuit breaker used for low-voltage applications, except that they are all electrically operated.

Compressed-air circuit breakers, or air-blast circuit breakers, depend on a stream of compressed air directed toward the separable contacts of the breaker to interrupt the arc formed when the breaker is opened. Air-blast circuit breakers have recently been developed for use in extra high-voltage applications with standard ratings up to 765,000 volts.

Oil circuit breakers (OCBs) are circuit breakers that have their contacts immersed in oil. Current interruption takes place in oil which cools the arc developed and thereby quenches the arc. The poles of small oil circuit breakers can be placed in one oil tank; however, the large high-voltage circuit breakers have each pole in a separate oil tank. The oil tanks in oil circuit breakers are normally sealed. The electrical connections between the contacts and external circuits are made through porcelain bushings.

Circuit Breaker Control

As we have discussed, circuit breakers may be remotely operated. In order to operate the breakers from a remote location, there must be an electrical control circuit incorporated. Figure 7 shows a simple control circuit for a remotely-operated breaker.

Control power is supplied by an AC source and then rectified to DC. The major components of a simple control circuit are: the rectifier unit, the closing relay, the closing coil, the tripping coil, the auxiliary contacts, and the circuit breaker control switch.

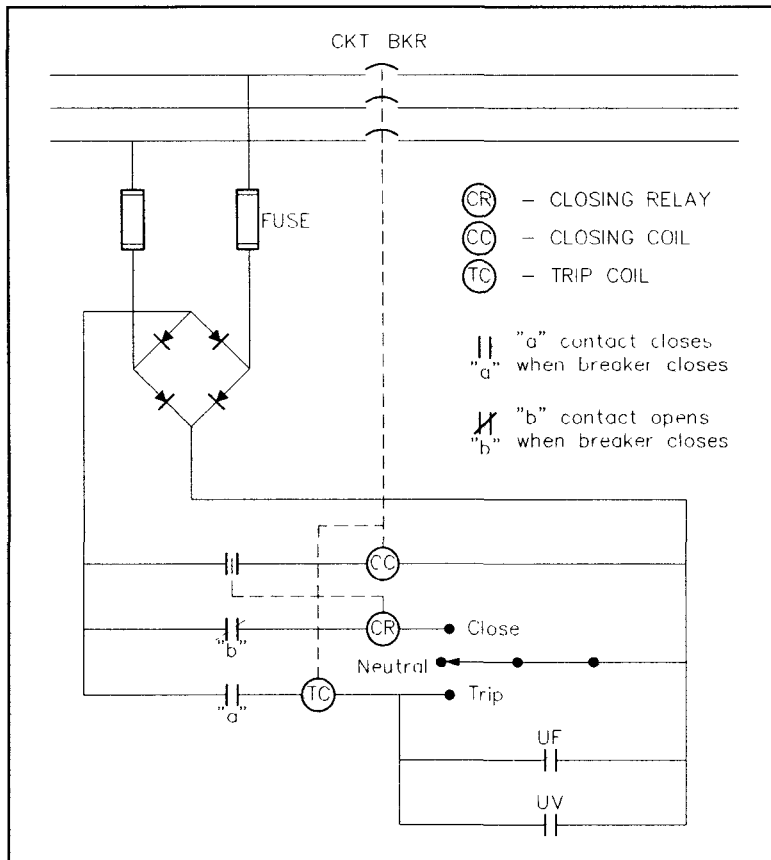

Figure 7 Simple Circuit Breaker Control Circuit - Breaker Open

To close the remotely-operated circuit breaker, turn the circuit breaker control switch to the close position. This provides a complete path through the closing relay (CR) and energizes the closing relay. The closing relay shuts an auxiliary contact, which energizes the closing coil (CC), which, in turn, shuts the circuit breaker, as shown in Figure 8. The breaker latches in the closed position. Once the breaker is shut, the "b" contact associated with the closing relay opens, de-energizing the closing relay and, thereby, the closing coil. When the breaker closes, the "a" contact also closes, which enables the trip circuit for manual or automatic trips of the breaker. The circuit breaker control switch may now be released and will automatically return to the neutral position.

To open the circuit breaker, turn the circuit breaker control switch to the trip position. This action energizes the trip coil (TC), which acts directly on the circuit breaker to release the latching mechanism that holds the circuit breaker closed.

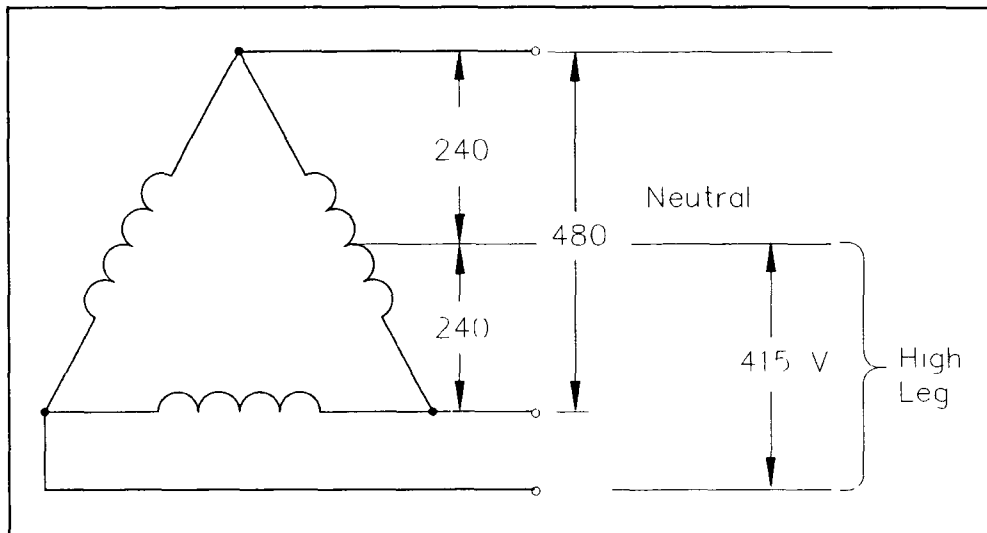

Figure 18 4-Wire Delta System

The single-phase voltage on each side of the half-tap is one-half the voltage available in the normal phase-to-phase relationship. This provides the same half- or full-voltage arrangement seen in the normal Edison scheme with a grounded neutral. Notice also that the legs coming from the corners of the Delta would have a normal ungrounded appearance if it were not for the center tap of one phase. Thus, at any given location in the system, either three-phase power at full voltage or single-phase power with half or full voltage is equally possible. However, there are several strict precautions that must be observed in the operation of this system. First, all loads must be carefully balanced on both the single-phase and three-phase legs. Second, because the voltage between one leg and the grounded neutral is considerably higher than the rest of the single-phase system, a measurement between the neutral and the phase must be taken to identify the "high leg," or "bastard voltage." Last, the "high leg" is never used as a single-phase source because no ground or grounded neutral exists for this circuit.

4-Wire, Three-Phase Wye System

Until now, the voltage, the phase voltage, and the ground voltage of the three-phase systems have been equal, with the one exception of one phase of the corner-grounded Delta. The Wye system has completely different voltage characteristics from the Delta system. In the Wye system, the ground voltage or voltage available from phase to ground is the phase voltage divided by 1.73.

In Figure 19, an example of the Wye system, or center-grounded Wye as it is commonly referred to, extends three current-carrying insulated conductors and an insulated grounded neutral to the loads. Depending on the selection of conductors, one of the following is available: a reduced-voltage single phase between a phase leg and the neutral; a full-voltage single-phase circuit between any two phase legs; or a full-voltage three-phase power. Again, some precautions must be taken when balancing the single-phase loads in the system. The full load ampacity of the neutral must be sized to 1.73 times the highest phase ampacity. This is done to avoid either an over-current condition if a fault is present or the operation of single-phase loads at reduced voltage if the loads become severely unbalanced by accidental interruption.

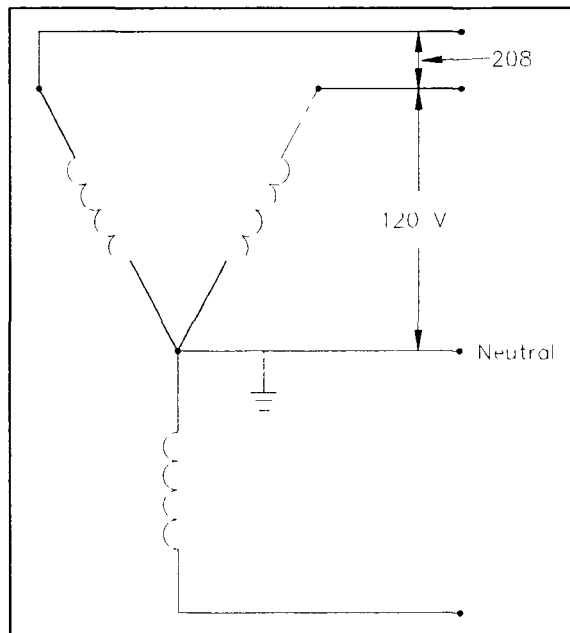

Figure 19 4-Wire, Three-Phase Wye System

As with all other grounded systems, bonds are established between the grounded neutral and all components of the system. This system is recognized as the safest possible multi-purpose distribution system for low voltage and is commonly seen in the 208/120-volt range in many facilities.

Summary

The important information in this chapter is summarized on the following page.

Wiring Schemes And Grounding Summary

Terminology

Ampacity - current-carrying capacity of a conductor in amperes

Bond - permanent joining of metallic parts or circuits assuring electrical continuity

Conductor - any wire, cable, or substance capable of carrying an electrical current

Ground - a conducting connection between a circuit or piece of equipment and the earth, or some body serving as earth

Ground voltage - the voltage between any given conductor and any point at ground potential

Leg - a current-carrying conductor intended to deliver power to or from a load

Neutral - a current-carrying conductor intended to deliver power to or from a load normally at an electrical potential other than ground

Phase voltage - the greatest root mean square (effective) difference of potential between any two legs of the circuit

Two methods to connect single-phase loads to a three-phase system are:

Phase-to-phase

Phase-to-ground

The purposes of the following wiring schemes are:

3-wire, single-phase Edison system - the only approved method of wiring single-phase power

3-wire, three-phase Delta system - normally used for transmission of power in the intermediate voltage class from approximately 15,000 volts to 600 volts

4-wire, three-phase Delta system - combines the ungrounded Delta for three-phase loads with the convenience of the Edison system for single-phase loads

4-wire, three-phase Wye system - the safest possible multi-purpose distribution system for low voltage

end of text.

CONCLUDING MATERIAL

Review activities:

DOE - ANL-W, BNL, EG&G Idaho,
EG&G Mound, EG&G Rocky Flats,
LLNL, LANL, MMES, ORAU, REEC_o,
WHC, WINCO, WEMCO, and WSRC.

Preparing activity:

DOE - NE-73
Project Number 6910-0017/4

Intentionally Left Blank