

# Science & Technology REVIEW

November 2003

National Nuclear  
Security Administration's  
Lawrence Livermore  
National Laboratory

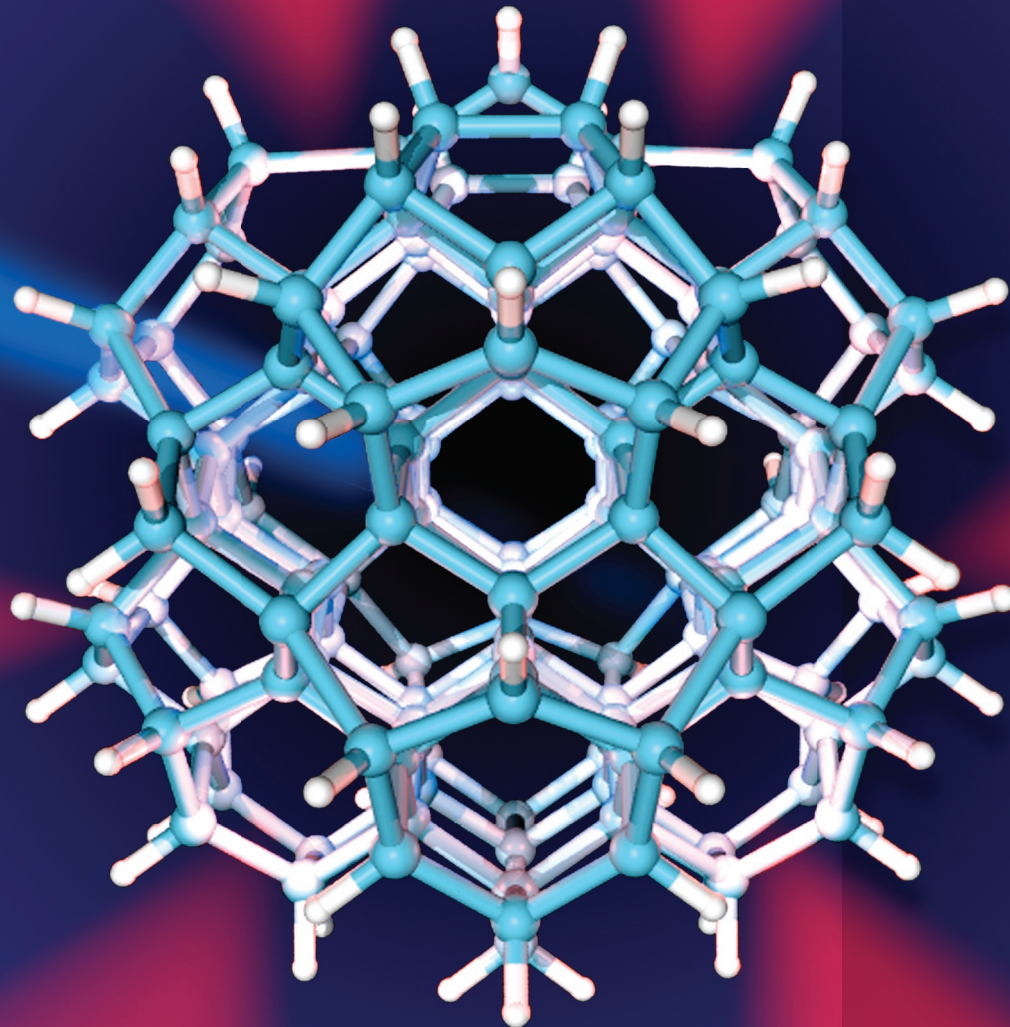

## Semiconductors at the Nanoscale

*Also in this issue:*

- **Microelectrode Array Developed for Eye Implant**
- **Levitating Train Goes Full Scale**
- **Fuel Processor Provides Longer-Lasting Power Source**

## About the Cover

The silicon nanoparticle shown on the cover is absorbing blue light and emitting red light after geometric rearrangements at the surface have taken place. These structural changes alter the particle's electronic properties and hence the color of light that it emits. The surprising properties of nanoscale semiconductors, including nanodiamonds, are featured in the article that begins on [p. 4](#).



## About the Review

Lawrence Livermore National Laboratory is operated by the University of California for the Department of Energy's National Nuclear Security Administration. At Livermore, we focus science and technology on assuring our nation's security. We also apply that expertise to solve other important national problems in energy, bioscience, and the environment. *Science & Technology Review* is published 10 times a year to communicate, to a broad audience, the Laboratory's scientific and technological accomplishments in fulfilling its primary missions. The publication's goal is to help readers understand these accomplishments and appreciate their value to the individual citizen, the nation, and the world.

Please address any correspondence (including name and address changes) to *S&TR*, Mail Stop L-664, Lawrence Livermore National Laboratory, P.O. Box 808, Livermore, California 94551, or telephone (925) 423-3432. Our e-mail address is [str-mail@llnl.gov](mailto:str-mail@llnl.gov). *S&TR* is available on the World Wide Web at [www.llnl.gov/str](http://www.llnl.gov/str).

© 2003. The Regents of the University of California. All rights reserved. This document has been authored by the Regents of the University of California under Contract No. W-7405-Eng-48 with the U.S. Government. To request permission to use any material contained in this document, please submit your request in writing to the Innovative Business and Information Services Department, Information Management Group, Lawrence Livermore National Laboratory, Mail Stop L-658, P.O. Box 808, Livermore, California 94551, or to our electronic mail address [report-orders@llnl.gov](mailto:report-orders@llnl.gov).

This document was prepared as an account of work sponsored by an agency of the United States Government. Neither the United States Government nor the University of California nor any of their employees makes any warranty, expressed or implied, or assumes any legal liability or responsibility for the accuracy, completeness, or usefulness of any information, apparatus, product, or process disclosed, or represents that its use would not infringe privately owned rights. Reference herein to any specific commercial product, process, or service by trade name, trademark, manufacturer, or otherwise, does not necessarily constitute or imply its endorsement, recommendation, or favoring by the United States Government or the University of California. The views and opinions of authors expressed herein do not necessarily state or reflect those of the United States Government or the University of California and shall not be used for advertising or product endorsement purposes.



Prepared by LLNL under contract  
No. W-7405-Eng-48

## Contents

### S&TR Staff

**SCIENTIFIC EDITOR**  
Donn H. McMahon

**MANAGING EDITOR**  
Ray Marazzi

**PUBLICATION EDITOR**  
Pam MacGregor

**WRITERS**  
Arnie Heller, Ann Parker,  
Gabriele Rennie, and Katie Walter

**ART DIRECTOR AND DESIGNER**  
Dan Moore

**COMPOSITOR**  
Louisa Cardoza

**PROOFREADER**  
Carolyn Middleton

*S&TR*, a Director's Office publication, is produced by the Innovative Business and Information Services Department under the direction of the Office of Policy, Planning, and Special Studies.

*S&TR* is available on the Web at [www.llnl.gov/str](http://www.llnl.gov/str).

Printed in the United States of America

Available from  
National Technical Information Service  
U.S. Department of Commerce  
5285 Port Royal Road  
Springfield, Virginia 22161

UCRL-52000-03-11  
Distribution Category UC-99  
November 2003

### Features

#### 3 **We Will Always Need Basic Science**

Commentary by Tomás Díaz de la Rubia

#### 4 **When Semiconductors Go Nano**

Experiments and computer simulations reveal some surprising behavior of semiconductors at the nanoscale.

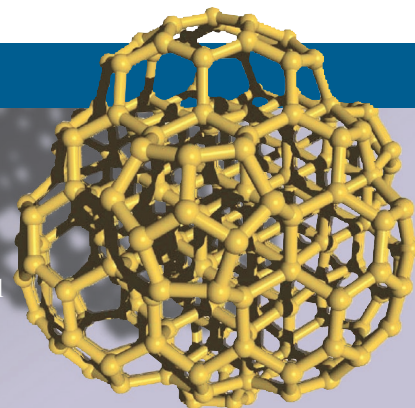

### Research Highlights

#### 11 **Retinal Prosthesis Provides Hope for Restoring Sight**

A microelectrode array is being developed for a retinal prosthesis.

#### 14 **Maglev on the Development Track for Urban Transportation**

Inductrack, a Livermore concept to levitate train cars using permanent magnets, will be demonstrated on a 120-meter-long test track.

#### 18 **Power Plant on a Chip Moves Closer to Reality**

Laboratory-designed fuel processor gives power boost to dime-size fuel cell.



### Departments

#### 2 **The Laboratory in the News**

#### 23 **Patents and Awards**

#### 25 **Abstracts**



### New method looks at protein folding

A new experimental method allows scientists to investigate the behavior of proteins under nonequilibrium conditions one molecule at a time. Developed by an international team of researchers, including Lawrence postdoctoral fellow Olgica Bakajin, this method will help researchers understand the fundamental biological process of protein folding. The work marks the first time protein-folding kinetics has been monitored on the single-molecule level.

Proteins are long chains of amino acids that loop about each other. Although a protein folds in various ways, only one form allows it to function properly. A misfolded protein can do serious damage and is a factor in diseases such as Alzheimer's and cystic fibrosis as well as in many cancers.

The research team, which included scientists from the National Institutes of Health and the Physikalische Biochemie Universität Potsdam in Germany, developed a microfluidic mixer to examine the protein-folding reaction. The mixer allowed them to examine a protein on a single-molecule level at defined times after the reaction began.

"With this method," says Bakajin, "we are able to isolate intermediate states that under equilibrium conditions exist only for a brief period of time." As a result, the team obtained data about the protein-folding reaction that were never available from ensemble measurements or even from the newer, single-molecule equilibrium measurements.

Results from this study were published in the August 29, 2003, issue of *Science*.

**Contact:** Olgica Bakajin (925) 422-0931 ([bakajin1@llnl.gov](mailto:bakajin1@llnl.gov)).

### Mapping the phonons in plutonium

In collaboration with the European Synchrotron Radiation Facility in Grenoble, France, and the University of Illinois at Champaign-Urbana, Livermore scientists have, for the first time, fully mapped the phonons in gallium-stabilized delta plutonium. The landmark experiment, which was led by Livermore chemist Joe Wong, promises to reveal much about the physics and material properties of plutonium and its alloys.

To measure the phonon dispersions, the research team used a high-resolution inelastic x-ray scattering technique developed at the European Synchrotron Radiation Facility. A microbeam from the highly brilliant x-ray synchrotron source impinged on a single grain in a polycrystalline alloy of delta plutonium and gallium.

Phonon dispersion data are fundamental to understanding the properties of plutonium materials, such as force constants, sound velocities, elasticity, phase stability, and thermodynamics. But experimental observations of plutonium are extremely difficult

because of the technical and safety issues involved in such studies. Until now, scientists couldn't measure phonon dispersions because they couldn't grow the large single crystals needed for inelastic neutron scattering.

"The new phonon data will greatly enhance scientists' understanding of the transformations and phases plutonium undergoes in different environments and over time," says Wong. "Basic knowledge of this sort is much needed and contributes greatly to the Laboratory's stockpile stewardship mission."

Results from this research appeared in the August 22, 2003, issue of *Science*.

**Contact:** Joe Wong (925) 423-6385 ([wong10@llnl.gov](mailto:wong10@llnl.gov)).

### Seismologists study mining blasts in the Baltics

In the northern region of Norway lies a seismic monitor sensitive enough to detect mining blasts as small as a few tons of explosive in neighboring Russia and Sweden. The seismic station, named ARCES, is one of at least a dozen temporary stations that were originally set up to ensure that countries were adhering to the Comprehensive Test Ban Treaty of 1996. It is now being used by Laboratory scientists to screen commercial mining explosions. The overall goal of the program is to distinguish whether a seismic signal is due to an earthquake, a conventional explosion, or a nuclear event.

The three-year project is providing real-time data on explosions conducted at principal mines within 500 kilometers of the ARCES seismic station. The Laboratory is partnering with NOR SAR—a nonprofit Norwegian research organization—and the Kola Regional Seismological Center in Russia to characterize the range of mining going on in northwest Russia and Sweden. From the signals observed by seismic stations, these researchers hope to determine whether the observed events are mine blasts and whether these blasts occur aboveground or underground.

Some minor natural seismicity in the area is caused by a rebound of Earth's crust following the melting of the continental ice sheet at the end of the Ice Age. However, according to David Harris, the Laboratory's principal investigator on the project, the majority of observed events are explosions at the many mines in the area. The diverse types of mining explosions make the area a natural laboratory for studying commercial explosions.

"The purpose is to observe how variable mining explosions are compared to nuclear explosions or earthquakes," Harris says. "The greater the variability, the more difficult it will be to devise effective screens for normal blasting activity."

To date, the project has collected data on 1,118 explosions in the Kola Peninsula and waveform data for about 700 of those events.

**Contact:** David Harris (925) 423-0617 ([harris2@llnl.gov](mailto:harris2@llnl.gov)).

*Continued on p. 22*





# We Will Always Need Strong Basic Science

**B**ASIC science often deals with the study of the fundamental behavior of the materials in our world. Whether the material being examined is plutonium or human biological tissue or an optical material or an anthrax spore, its structure and properties must be fully understood for researchers to be confident in predicting performance.

I believe strongly that a place like the Laboratory excels in part because for us basic science is not an end in itself, but rather a means to an end. At Livermore, we strive for strong basic science, but we do so in areas that are driven by our mission as an applied science laboratory serving the national interest.

Plutonium, for instance, with its six crystal forms, is a highly idiosyncratic element, and understanding its properties remains one of the most challenging problems in condensed matter and materials physics. At the same time, plutonium is arguably the most important material in the nuclear weapons stockpile. For most of the last 50 years, the Laboratory has relied heavily on underground nuclear testing to verify weapon performance and gather selected information about the behavior of plutonium. The data were used to adjust our computer codes so that over the years they would become increasingly better predictors of weapon performance. However, many of the intricacies of plutonium behavior remained a mystery. More recently, through the National Nuclear Security Administration's Stockpile Stewardship Program and our own discretionary investments, Livermore researchers have been developing new theoretical and experimental approaches aimed at understanding the fundamental properties of plutonium in exquisite detail. Undoubtedly, the advances being made through these basic science efforts will eventually result in improved models in the weapons codes and, therefore, in increased confidence in our ability to simulate the reliability and performance of the nuclear weapons stockpile.

The article beginning on [p. 4](#) is another example of the basic science at which Livermore excels. In this instance, experimentalists and simulations experts are delving into the behavior of semiconductors at the nanoscale. Specifically, they are examining silicon, germanium, and nanodiamond, a form of carbon. The electronic and optical properties of these materials are very different at the nanoscale than they are in those same materials in the bulk form, thanks to a phenomenon known as

quantum confinement. Silicon and germanium emit light at the nanoscale, which they do not do in the bulk form. And the small size of these nanoparticles—just tens of nanometers across, far smaller than the width of a human hair—means that a large percentage of their atoms is at the surface.

By exposing nanoparticles of silicon and germanium to the x rays of huge synchrotron facilities, experimentalists have produced new data about the structure of these materials. At the same time, computer models have revealed insights about how changes to the surface of semiconductor dots produce dramatic changes in their electronic and optical properties. This synergy of experiments and simulations is adding to the growing body of knowledge about these fascinating elements.

Recent simulations of nanodiamond were the first ever performed anywhere. They have shown that at the nanoscale, a molecule of diamond can become a buckyball, the soccer-ball-shaped molecule named for R. Buckminster Fuller, inventor of the geodesic dome. The full ramifications of this unexpected finding are not yet understood, but we can be sure that Livermore's scientists will soon learn.

The nanoworld is an exciting, unexplored scientific frontier. We strive to consistently offer a range of exciting basic research ventures to attract excellent young scientists to this Laboratory. We understand that any dedicated scientist finds basic science research to be fascinating and profoundly satisfying. We sometimes don't know where or how the basic research will be applied. But we know that when basic science is inspired by the mission-driven priorities of the Laboratory, applications will abound.

---

■ Tomás Díaz de la Rubia is associate director for Chemistry and Materials Science.





# When Semiconductors Go Nano

*At the nanoscale, silicon, germanium, and diamond take on unexpected characteristics.*

**W**E all know diamonds, or we think we do. Diamonds are a girl's best friend, sang Marilyn Monroe in the movie *Some Like it Hot*. They appear on many a third finger, brilliantly faceted and sparkling. On a more practical note, because diamonds are one of the hardest substances on Earth, the industrial sector makes extensive use of them.

Who would suspect then that the most miniscule bit of diamond, just a few

hundred atoms, would take on the exotic shape of a fullerene or buckyball at the surface? At the nanoscale—a nanometer is a billionth of a meter or 1,000 times smaller than the diameter of a human hair—materials behave differently than they do in their larger, bulk form. In this size regime, the laws of quantum mechanics predominate.

Yet the recent revelation that the outer surface of a molecule of diamond, a

nanodiamond, is shaped like a soccer ball came as a real surprise. The discovery was made by a Livermore team that for the first time computationally modeled nanodiamonds to determine their optical properties. They had previously modeled two similar semiconductor materials, silicon and germanium, and expected about the same results.

Physicist Giulia Galli, who leads Livermore's Quantum Simulations Group,



says, “At the nanoscale, the surface of silicon and germanium rearranges its atomic geometry in a way that somehow compresses the core of the nanostructure.” To their amazement, the team found that nanodiamond expands, with a crystalline diamondlike core and a fullerene-like structure around it at the surface.

The first fullerene was a 60-atom carbon buckyball. Livermore’s simulations are the first to reveal bucky diamonds, a new family of carbon clusters. The discovery of the bucky diamond was just one recent finding by a research team led by Galli and Tony van Buuren, an experimental physicist. The team performs quantum molecular simulations and scrutinizes materials experimentally as they seek to better understand the properties of the semiconductor materials silicon, germanium, and diamond at the nanoscale. As part of the Group IV series of elements on the periodic table, these three materials share some interesting properties, as described in the [box on p. 10](#).

According to physical chemist Lou Terminello, materials program leader for the Defense and Nuclear Technologies Directorate, Livermore research on semiconductor nanostructures—also known as nanodots or quantum dots—is

aimed primarily at using them in detectors to reveal the presence of biological or chemical warfare agents. A protein added to the surface of one of these nanoparticles would change when exposed to a biological agent, serving as an indicator.

At the nanoscale, silicon and germanium emit light when stimulated. Nanodiamond, which has more recently come under the microscope, may also change its optical properties as a function of size. In bulk form, all three semiconductors are compatible with biological materials and so could easily be linked with a protein. Whether this biocompatibility still exists when the semiconductors are reduced to the nanoscale remains to be determined. If these nanosemiconductors are indeed biocompatible, their optical, or light-emitting, properties could be exploited to detect specific molecules.

Other uses for light-emitting semiconductor nanoparticles include photonic switches, tunable lasers, and nanocrystal solar cells. Terminello adds, “Quantum dots will likely be some of the next-generation materials for targets at the National Ignition Facility.” By starting with nanostructures, scientists could dictate the target’s precise design. Atom by atom, they could gradually build up

the targets in size from the nanoscale to macroscopic structures.

Nanoscience—the study of the very small—is fundamental to U.S. research. Funding by the U.S. government for nanoscience and nanotechnology is higher than ever, just behind defense spending and funding for biological research. Before tiny bits of any material can be put to use, their unique properties must be better understood. As the recent discovery of the bucky diamond illustrates, the world of Group IV semiconductor nanostructures is still a mystery.

### Small Size, Big Change

Reducing any piece of material from a chunk that we might recognize to the nanometer scale changes virtually all of its most basic properties in a fundamental way. Its shape and crystalline structure change, as do its melting and boiling temperatures. Its magnetic properties may be different at the nanoscale. Its optical and electronic properties also change.

In a nanosemiconductor, an effect known as quantum confinement occurs when electrons and “holes” in the material are confined. (A hole is the absence of an electron; the hole behaves as though

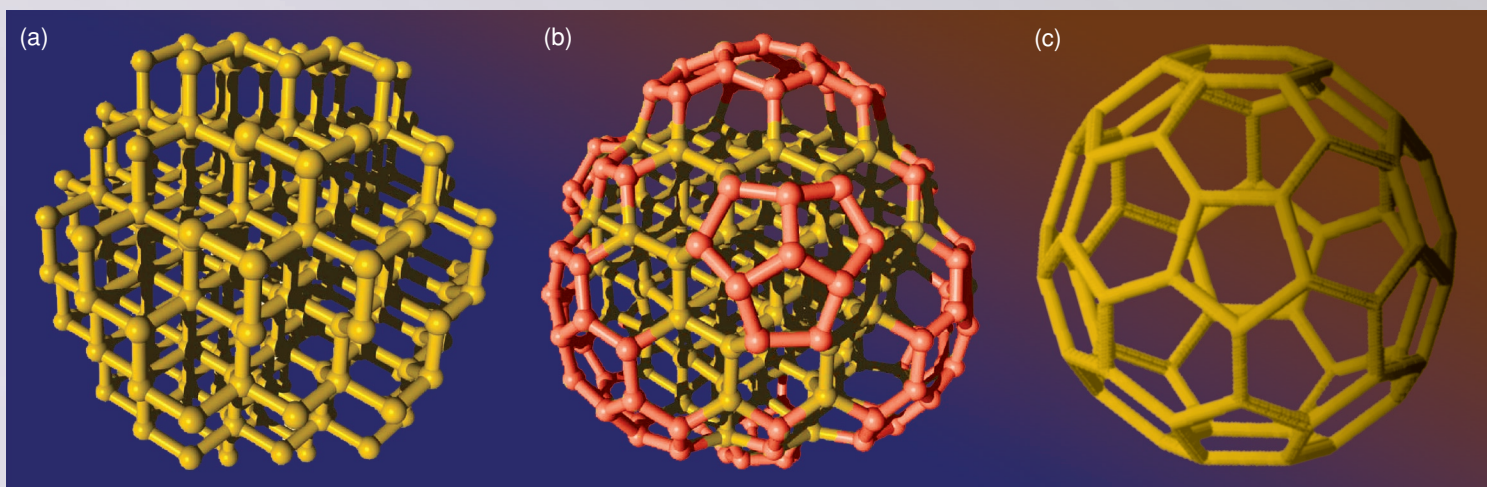

Fullerenes, or buckyballs, are soccer-ball-shaped molecules named for R. Buckminster Fuller, whose popular geodesic dome is structurally similar to a fullerene molecule. In first-principles simulations of nanodiamond, (a) the surface of a 1.4-nanometer nanodiamond with 275 atoms spontaneously rearranges itself into (b) a fullerene at about 300 kelvins. These carbon clusters have a diamond core (yellow) and a fullerene-like reconstructed surface (red). (c) A classic 60-atom carbon buckyball.



it were a positively charged particle.) Typically, quantum confinement causes the material's optical gap—the energy difference between filled states and empty states—to widen. A larger optical gap prompts dramatic changes in electronic and optical properties. Bulk silicon when stimulated does not emit visible light, but in 1990, researchers found that nanoparticles of silicon do.

Livermore researchers and others have since determined that silicon nanoparticles emit different colors of light depending on their diameter. In 1997, germanium nanoparticles were found to emit light. In the last two years, other Livermore scientists have discovered that the optical gap of nanodiamond does not change until its size is reduced to less than 2 nanometers.

Nanoparticles are also different from the bulk form of the material in that the percentage of atoms at or near the surface of the particle is far greater. The surface of nanoparticles thus plays a large role in determining the particle's electronic and optical properties.

### It Started with Silicon

Livermore's first work with Group IV semiconductor nanostructures took place in the mid-1990s. The photoluminescence of

silicon had only recently been discovered, indicating that this element might be a promising material for optical applications.

Livermore researchers used a gas-phase vaporization process, in which melted silicon was heated and vaporized in the presence of a buffer gas, to synthesize silicon particles ranging from 1 to 6 nanometers. Numerous production techniques exist, but most of them allow only limited size control of the resulting particles. They also produce particles with a specific surface chemistry that is less useful for investigations of precise electronic structure.

Either hydrogen or oxygen was then bonded to the surface of the tiny molecules to "passivate" the dangling bonds of highly reactive silicon. Using spectroscopic and x-ray absorption techniques to probe the particles' characteristics, the Livermore team was the first to measure the band edges of the optical gap of silicon and to determine that the gap changes as the nanoclusters become smaller. These findings clearly indicated the importance of the quantum confinement effect on the optical properties of silicon nanoclusters.

Subsequent fine-tuning of the synthesizing process made it possible to produce silicon nanoclusters in an even

narrower distribution of sizes ( $\pm 7$  percent of average size) as measured using an atomic force microscope. Work in the late 1990s definitively correlated quantum confinement changes as a function of the size of silicon nanoparticles, in agreement with quantum confinement theory.

As Livermore and other research institutions worldwide experimented further with semiconductor nanoclusters, their potential uses as biological markers and nanostructure lasers became more evident. With increased concerns about bioterrorism, van Buuren and Galli obtained funding from the Laboratory Directed Research and Development Program to develop atomically controlled nanostructures for biowarfare detectors. Their team, composed of researchers from the Physics and Advanced Technologies and the Chemistry and Materials Science directorates, is relatively large. As interest in all things nano has burgeoned, the number of nanoscience experts at Livermore has grown.

### Simulations Verify and Surprise

The traditional purpose of computerized simulations of physical phenomena is to verify experimental findings. But simulations can also go where an experiment cannot. This is especially true for examining the surface of nanoclusters. The effects of quantum confinement on semiconductor nanodots can be obtained experimentally; however, the changes in the properties of the comparatively large surface area of a nanostructure are difficult to determine in experiments. First-principles simulations, which do not contain any input from experimental data, are a valuable tool for discovering the dependence of a nanostructure's optical and mechanical properties on its surface structure.

Using Livermore's massively parallel supercomputers, Galli's group has undertaken several computational studies of the surface chemistry of Group IV semiconductor nanoclusters. An early

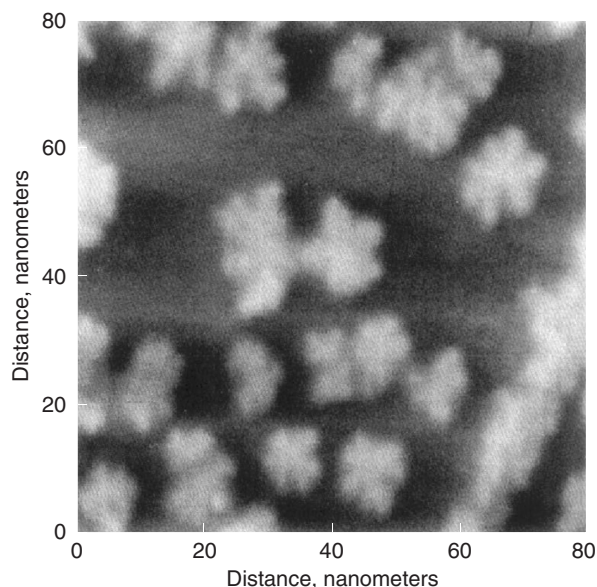

An image of silicon nanocrystals using an atomic force microscope. The nanocrystals, produced using gas-phase vaporization, range from 1 to 4 nanometers. Note how the nanoclusters gather at the step edges of the graphite substrate or assemble into snowflake-like superclusters.

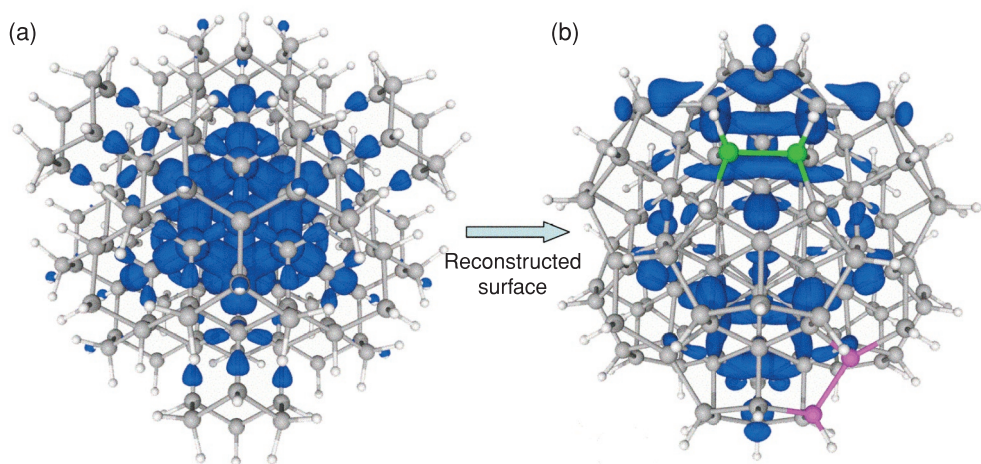

(a) The “idealized” structure of a 1.8-nanometer silicon nanodot. When the molecule is removed from a larger piece of bulk silicon, each silicon atom is ideally terminated with a hydrogen atom. (b) But at the nanoscale, the molecule instead reconstructs. Its electronic properties change considerably, increasing the optical gap.

study used density functional theory and quantum Monte Carlo codes to perform first-principles calculations of the surfaces of silicon nanoclusters. The group examined the effect of replacing one or more atoms of a hydrogen-passivated silicon nanocluster with other passivants. A remarkable change results when just two hydrogen atoms are replaced by more reactive oxygen atoms. The electron charge cloud is drawn toward the oxygen atom, dramatically changing the optical properties of the silicon dot.

From these and many similar calculations, the group has concluded that quantum confinement is only one mechanism responsible for a semiconductor’s light-emitting properties. For example, they have confirmed experimental findings by researchers outside the Laboratory that oxygen passivation of silicon dots reduces their optical gap while hydrogen passivation increases it.

A recent study modeled spherical silicon clusters ranging from 53 to 331 atoms (0.7 to 2.0 nanometers), the largest nanoparticles ever studied with the highly accurate quantum Monte Carlo technique. A team examined the

process of surface reconstruction—in which unstable dangling bonds on a nanoparticle’s surface spontaneously rearrange themselves—and its effects on the particle’s optical properties. In this study, the team found that reconstruction of the surface of silicon nanostructures could have the effect of compressing the nanoparticle. “Time and again, we have found that the specific surface chemistry must be taken into account if we want to quantitatively explain

the optical properties of semiconductor nanoparticles,” says Galli.

### Germanium Joins the Fray

Although germanium was used extensively in early semiconductor devices, it has since been displaced by silicon as the substrate for most devices. But the 1997 discovery that nanodots of germanium emit light sparked a new interest in this element.

While he was at Livermore as a graduate student of the University of Hamburg, Germany, physicist Christoph Bostedt improved Livermore’s earlier vaporization chamber for synthesizing semiconductor nanoparticles. Among the many modifications he made, the chamber can now synthesize nanoparticles composed of virtually any element. Using this chamber, Bostedt found that by varying preparation parameters, he could dictate the size of the resulting germanium particles.

Now a Livermore postdoctoral fellow, Bostedt is using synchrotron radiation at Lawrence Berkeley National Laboratory’s Advanced Light Source (ALS) for photoemission spectroscopy and x-ray absorption studies of the electronic microstructure of germanium nanocrystal films. “Using ALS, we have produced spectra for germanium that are some of the best obtained anywhere,” he says.

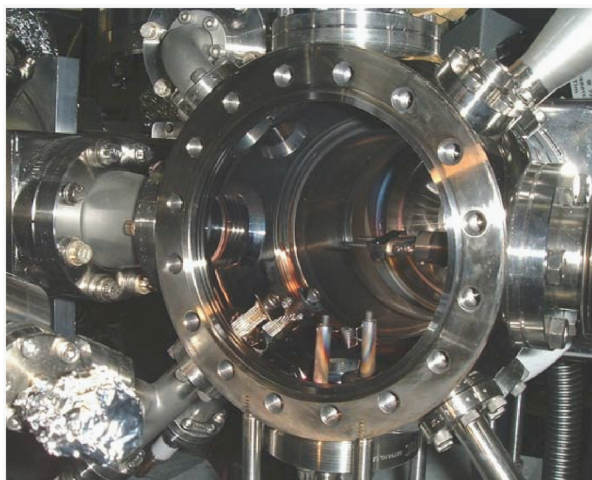

Livermore’s latest gas-phase chamber for synthesizing nanosemiconductors is portable so that nanodots can be prepared and deposited in situ. This gas-phase condensation technique works for virtually all elements, is ultra clean, and produces a wide range of sizes of nanocrystals whose surface chemistry can be manipulated.



Most recently, his team has shown in experiments with ALS that quantum confinement effects are greater in germanium nanocrystals than in silicon nanocrystals for particles smaller than 2 nanometers. The strong confinement they observed and the fast opening of the optical gap—which translate into a highly “tunable” material—indicate germanium nanocrystals would be especially useful in detectors and optoelectronic applications that require extreme sensitivity.

In the theoretical community, others have made similar predictions about the quantum confinement of germanium versus silicon, although considerable controversy

exists. The Livermore team is the first to make this discovery experimentally using thin films of germanium nanocrystal, finding that the behavior of germanium nanocrystals is as sensitive to changes at the surface as silicon. “We believe that disagreements between our experimental results and some theoretical predictions are due to the structural details of the nanocrystals,” says Bostedt. “The structure, especially at the surface, of nanocrystals cannot be ignored.”

Theoretical models that do not use sophisticated quantum simulations typically use idealized nanocrystals isolated in space and not resting on any

surface. The nanodot’s atomic structure is almost always ignored as well. In contrast, a quantum Monte Carlo investigation at Livermore into the structure and stability of germanium nanoparticles revealed the key role that structure plays. The simulations team found that the surface of germanium nanodots reconstructs when their diameters are smaller than 2.5 to 3 nanometers, a geometric rearrangement that agrees with the Laboratory’s photoemission experiments at ALS.

### The Surprising Nanodiamond

Nanodiamond, the most recent Group IV semiconductor to be examined at Livermore, offers plenty of surprises. Livermore is one of the few research groups in the world to perform quantum simulations of nanodiamond behavior.

Livermore data show that the size of nanodiamond must be reduced to less than 2 nanometers before its optical gap increases beyond that of the bulk form. This behavior differs dramatically from that of silicon and germanium where quantum-confinement effects persist in particles of up to 6 and 7 nanometers. These results came from both computer simulations and x-ray absorption and emission experiments using ALS and the Stanford Synchrotron Radiation Laboratory. Both studies aimed to derive a structural model for nanodiamond.

The bucky diamond appeared during calculations of surface reconstruction of 1.4-nanometer diamond particles, which Galli performed with physicist Jean-Yves Raty of Livermore and the University of Liege, Belgium. These simulations started with bare, unpassivated nanodiamond. At low temperature, the bucky diamond reconstruction occurred spontaneously. The first faceted layer took on the properties of graphite, which was followed by the formation of pentagons linking the graphene fragments with atoms underneath. This change made the surface increasingly curved, eventually resulting in an arrangement like half of

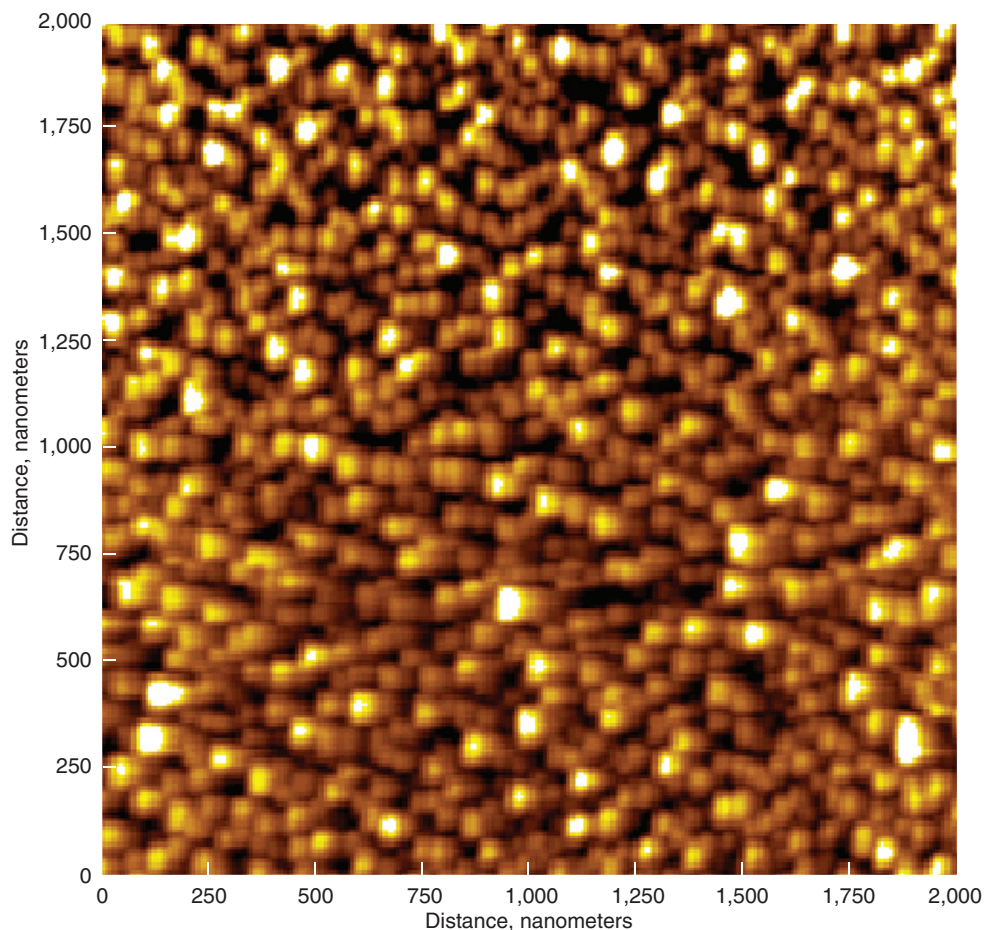

Most applications using nanomaterials will require thick films of nanocrystals, such as these germanium nanodots shown under an atomic force microscope.



a 60-atom carbon molecule, the classic buckyball. Simulations showed similar results for surface reconstructions of 2- and 3-nanometer clusters.

These results point yet again to the importance of nanoparticle surfaces. “When the calculations and measured spectra of nanodiamonds are compared,” says van Buuren, “it becomes clear that the surface reconstruction identified by computer simulations is consistent with the features observed in absorption spectra.”

Nanodiamond is interesting because it has been found in meteorites, interstellar dusts, and protoplanetary nebulae, and it appears in residues of detonation. (Nanoparticles of diamond for Livermore experiments are obtained through synthesis from detonation.) And regardless of whether they come from meteorites or detonation, most nanodiamond particles fall in the 2- to 5-nanometer range. Other nanomaterials display a much wider range of sizes even at this small scale.

Raty and Galli used computational methods to explore the causes for this size limitation. The team found that at about 3 nanometers—and for a broad range of pressure and temperature conditions—particles with bare, reconstructed surfaces become thermodynamically more stable

than those with hydrogenated surfaces, and hydrogenation prevents the formation of larger grains.

### Prediction Is the Goal

“Understanding how size and surface affect optical and electronic properties is what our research is all about,” says van Buuren. Experimentalists and quantum simulation experts are working together to establish a basic knowledge of the structure and optical properties of semiconductor nanostructures. Their goal is to match these two sets of data and form an ability to predict the characteristics of nanoparticles. Someday, a scientist will know exactly how to produce a nanowidget to detect a deadly pathogen. Perhaps the widget must emit blue light, and the scientist will know that using a nanoparticle of a given size and density produces the desired wavelength.

In the meantime, moving toward that goal, Livermore researchers are beginning to observe the interaction among nanostructures. One team recently performed quantum simulations of the interplay of silicon quantum dots, an inorganic material, and organic molecules, which will be essential in a semiconductor biodetector. In particular, investigators simulated what occurs when organic molecules are attached to silicon quantum

dots. They found that the probability of attaching an organic molecule to a nanodot is greatly increased if light shines on the nanodot, a result that agrees with recent experimental findings by others. Their simulations also indicated a way to select silicon quantum dots with a specific optical gap at the same time that organic molecules are being attached.

Next on Bostedt’s agenda is to make thick films on which germanium particles are closer together and touching, which is how they will be in real-world applications. Unfortunately, when they touch, nanosemiconductor particles tend to lose some of their special electronic properties. Bostedt has developed a surface passivation technique that keeps the particles isolated, reducing the effect of touching. Further experiments will examine the interface where interactions occur between passivated layers to determine what happens to the electronic properties of the entire device.

Others on the team are starting simulations and experiments to explore the structural and optical properties of silicon and germanium nanoparticles in solution. A new two-step cluster aggregation source is under development that will allow for wet chemical modification of the surface of crystalline

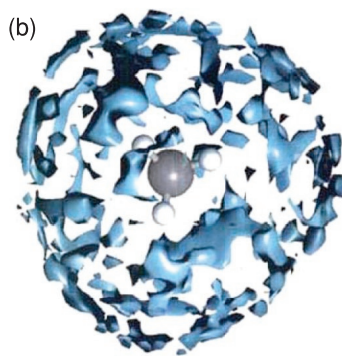
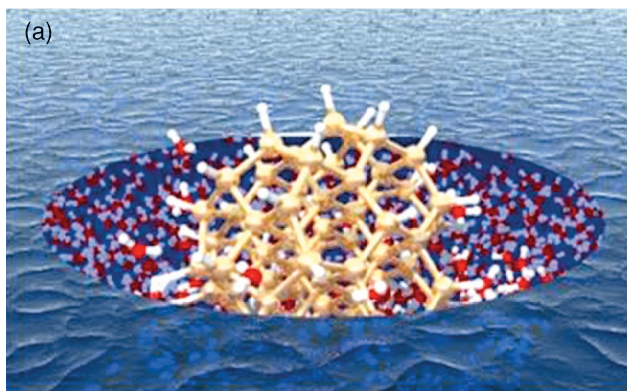

Methane

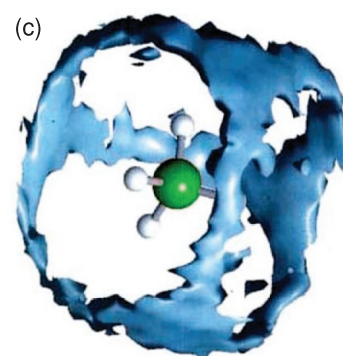

Silane

(a) Simulation of a silicon nanostructure in water. (b) and (c) Monte Carlo simulations from first principles of nanodiamond precursors in water. Both (b) methane and (c) silane are forms of carbon and are hydrophobic; that is, they repel water, just as oil repels water. Although the methane and silane are similar structurally, they interact with water quite differently.

## The Periodic Table of Semiconductors

A semiconductor is a crystalline solid that in its pure form exhibits a conductivity midway between that of metals and insulators. The three semiconductor materials that Livermore is studying for possible use as sensors and detectors are silicon, germanium, and diamond. Silicon accounts for almost 99 percent of all commercial semiconductor products. Germanium became famous when the transistor was invented but has since been replaced largely by silicon. Diamond, a monocrystal of carbon, has the physical properties of a wide-optical gap semiconductor, but current technologies do not allow its use as a semiconductor.

These three materials comprise some of the Group IV elements on the periodic table, as shown below. Tin, the fourth potential semiconductor material in this group, has the physical properties of a semiconductor at low temperatures but at room temperature behaves like a metal. These four materials are elemental semiconductors.

Elements in Groups II and VI and in Groups III and V are often combined to form compound semiconductors. Gallium–arsenide

is a typical Group III/V compound semiconductor often used in microwave devices and optoelectronics. Most experiments designed to explore the optical properties of semiconductor nanoclusters have focused on such Group II/VI compound semiconductors as cadmium–selenium.

In contrast, the synthesis of covalently bonded nanoparticles such as silicon has proven to be much more challenging. Silicon and other Group IV semiconductor elements are thus much less well characterized than Group II/VI compounds, and the interplay of quantum confinement and surface properties is less clear. Yet silicon is the preferred material for biomarkers because of its compatibility—at least in its bulk form—with biological materials. Silicon nanoclusters could also be integrated with existing silicon technologies to create nanoscale optoelectronic devices. Germanium and nanodiamond have been studied much less than silicon, but their intriguing characteristics inspire hope that they may be useful as well.

I	II	III	IV	V	VI	VII	VIII
Lithium	Beryllium	Boron	Carbon	Nitrogen	Oxygen	Fluorine	Neon
	Magnesium	Aluminum	Silicon	Phosphorus	Sulfur		
	Zinc	Gallium	Germanium	Arsenide	Selenium		
	Cadmium	Indium	Tin	Antimony	Tellurium		

silicon nanoparticles produced in the gas phase. This work is a major step toward producing silicon nanoparticles that are useful for biological applications.

As the world faces ever-changing threats and often-unseen enemies, research that enhances our ability to respond is critical. With this research on nanosemiconductors for use in biodetectors, Livermore brings its unique computational and experimental expertise to bear on an issue of extreme importance.

—Katie Walter

**Key Words:** biodetector, buckyball, germanium, nanocluster, nanocrystal, nanodiamond, nanoparticle, nanoscale, nanoscience, nanotechnology, quantum dot, quantum molecular simulations, semiconductor, silicon.

**For further information on experiments, contact Tony van Buuren (925) 423-5639 ([vanbuuren1@llnl.gov](mailto:vanbuuren1@llnl.gov)), or on simulations, contact Giulia Galli (925) 423-4223 ([galligygi1@llnl.gov](mailto:galligygi1@llnl.gov)).**

# Retinal Prosthesis Provides Hope for Restoring Sight

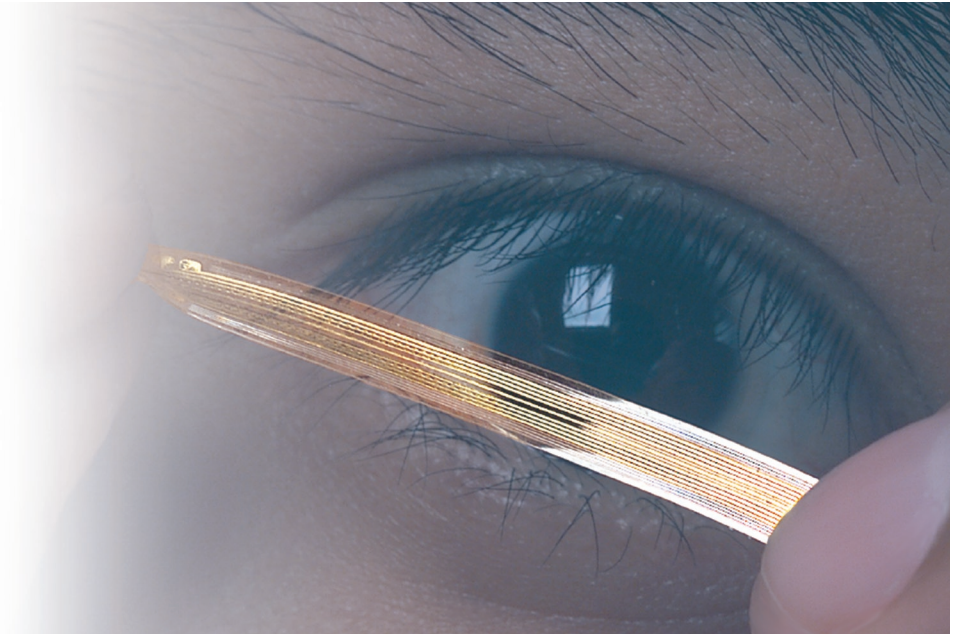

A microelectrode array developed for a retinal prosthesis device. The electrodes are embedded in silicone-based substrate polydimethylsiloxane (PDMS). PDMS is a promising material for the microelectrode array, providing flexibility, robustness, and biocompatibility for long-term implantation.

**V**ISION involves a complex process requiring numerous components of the human eye and brain to work together. When light enters the eye, nearly 127 million rods and cones, which are the photoreceptors in the retina, initiate a series of electrical signals so rapid that the images the eye receives appear to be continuously updated in a seamless process. A breakdown in this light-conversion process can lead to vision impairment or loss of sight.

A team of Lawrence Livermore engineers and scientists is participating in a national effort to develop a technology that would help restore sight to those who are legally blind from the loss of photoreceptor function. Attached to and functioning as the eye's retina, the retinal prosthesis device promises hope for those with age-related macular degeneration, retinitis pigmentosa, or related diseases where photoreceptors are damaged but the optic nerve and its connections to the brain are still intact.

The Department of Energy's Office of Science has committed \$9 million over three years to retina research as part of the department's medical applications technology program. Courtney Davidson, electrical engineer and Livermore's lead on the project, is collaborating with colleagues from Oak Ridge, Argonne, Sandia, and Los Alamos national laboratories; the University of California (UC) at Santa Cruz; University of Southern California's (USC's) Doheny Eye Institute; North Carolina State University; and Second Sight, a private company that plans to commercialize the prosthetic device. The project is in its second year of funding.

Davidson and team members Satinderpall Pannu, Julie Hamilton, and Terri DeLima are part of Livermore's Center for Micro and Nanotechnology. The center is applying its expertise in the area of microelectromechanical systems (MEMS), which integrates millimeter-size mechanical elements, sensors, actuators, and electronics through microfabrication technology. The center's recent successes include developments in microfluidic filtration devices, microsensor technology with increased sensitivity, and micro fuel cells.

Davidson continues the work begun by his predecessors, engineers Peter Krulevitch and Mariam Maghribi, to develop an electrode array for the retinal prosthesis. The array will serve as the interface between an electronic imaging system and the eye, providing electrical stimulation normally generated by the photoreceptors that convert visual signals to electrical signals transmitted to the optic nerves. The goal is to develop a 4- by 4-millimeter array with 1,000 electrodes attached to a microchip system that powers them.

## Designing Biocompatible Electronics

The electrode array is embedded in a silicone-based substrate, polydimethylsiloxane (PDMS). Livermore researchers previously used PDMS as a substrate for microfluidic tools in devices that collect and identify biological pathogens such as proteins, viruses, and bacteria. Additionally, Livermore efforts have focused on developing processes for embedding metal electrodes within PDMS for use in biomedical applications.



Davidson notes that PDMS is a biocompatible material, making it suitable for implants. While PDMS is somewhat permeable to oxygen, it is highly impermeable to water. This feature is expected to enable long-term implants where the electrodes must be isolated from corrosive and electrically conductive body fluids. The flexible nature of PDMS also allows the embedded electrodes to conform to the shape of the retina. Sandia and Livermore are each developing microfabrication processes and prototype electrode arrays in an effort to determine the best interface with the retina.

Mark Humayan, a retinal surgeon and biomedical engineer at USC's Doheny Eye Institute, is testing prototypes of the Livermore implants to determine how well the materials work and how long they are likely to last after implantation. Davidson says, "We've shown we can build electrode sets on PDMS, and we're looking at concepts that will increase the number of electrodes on a small area and allow a surgeon to test the device for conformability and robustness."

This past spring, surgeons at USC successfully implanted a prosthetic device in a dog's eye. The objectives were to determine how well the device conformed to the retina, the mechanical

effects of the device on the retina, and any biocompatibility issues. Scanned images using optical coherence tomography showed the conformity of the implanted array on the retina. Surgeons were pleased with the results.

The device is designed to be epiretinal; that is, it will be placed on the surface of the retina inside the eye. The implant will overlap the center of the eye's visual field, which is the area affected in macular degeneration. Once implanted, a small camera attached to eyeglasses will capture a video signal that will be processed and transmitted inside the eye using a radio-frequency (rf) link. The rf link is composed of an external rf coil that will either be part of the eyeglass apparatus or will rest on the eyeball like a contact lens. Another rf coil inside the eye will pick up the signal and transmit it to electronics that will format the signal for stimulating the electrode array.

**Powering Electrodes Inside the Eye**

The power for the circuitry, or microchip system, will be provided inductively through transcutaneous coupling. That is, a coil attached to a battery on the side of the eyeglasses will inductively generate

(a)

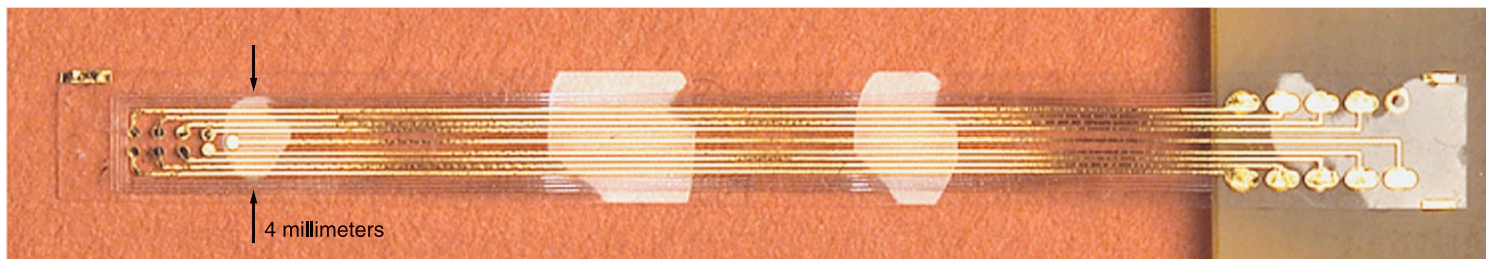

(a) Photograph of a prototype PDMS array used in testing.  
 (b) Cross-section of an eight-electrode polydimethylsiloxane (PDMS) device shows conductive lead and electrode metallization contained between two layers of PDMS. Reinforcement ribs facilitate handling of the thin PDMS device. A tack hole is used to pin the device to the retina.

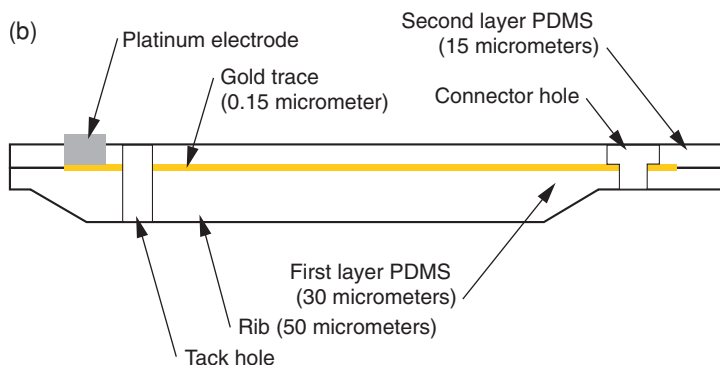

power in a coil parallel to it under the skin. Wen Tai Liu, an engineer at UC Santa Cruz, is researching the requirements for the external camera and transmitter to determine the amount of power required by the implanted device and how best to supply the power.

North Carolina State University researcher Gianluca Lazzi is modeling the biological effects of retinal stimulation, notably, thermal dissipation. Davidson explains, “The electrodes must be stimulated in a very controlled manner. The amount of time you stimulate them and the amount of time given between the pulsing electrodes are critical. It’s not certain what stimulation might be required to artificially generate normal vision. This is an extremely interesting area for both basic and clinical research.” Los Alamos researcher John George is developing optical imaging techniques to observe the visual neural system and to better understand electrical stimulation of the retina.

Implanting electrical stimulation hardware within the fragile biological environment of the human eye poses challenges. Charged metal electrodes produce gases such as hydrogen and generate toxins that can damage tissues. Eli Greenbaum, project manager at Oak Ridge, is performing electrochemical tests of the electrodes to determine the limits before tissue damage. Second Sight is conducting experiments to determine the robustness of the device and producing prototypes. Argonne is developing an encapsulating package that will insulate the electronics to help assure that the implant will last a lifetime.

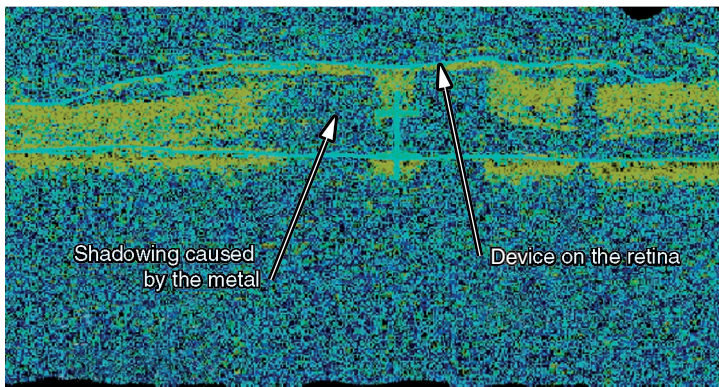

Optical coherence tomography scans taken one week after the prosthetic device is implanted in a dog's eye show it is conforming to the retina.

One challenge for the team is determining the best electrode metal for the array. Gold was a useful material for preliminary studies, but platinum has proven to be a better choice for biocompatibility. The questions now are what is the best design for the array and what method should be used to attach platinum to the PDMS substrate.

Another challenge is determining the correct density of electrodes. While a small number of electrodes may provide favorable results, the optimum density of electrodes is still to be established. The current operational goal is to produce 1,000 electrodes. An additional challenge is finding the best method to connect the microchip system to the electrode array.

A commercially available retinal prosthesis is at least a few years away. While the retinal project continues, Davidson is working on other potential applications of this technology. “Many parties are interested in collaborating with the Laboratory on other applications for the microarrays,” he says. “For example, with just over a dozen electrodes in a prosthesis for hearing, you can get amazing results.” In addition to a cochlear (hearing) implant, possibilities include a deep brain stimulation device for treating diseases such as Parkinson’s and a spinal cord stimulation device for treating chronic pain.

Initially, the retinal device will rely on an external camera transmitter, but researchers hope to develop a complete implantable system. The Livermore team is encouraged with the results of the research that may help to restore eyesight to blind persons and may revolutionize the treatment for many neurologically based illnesses.

—Gabriele Rennie

**Key Words:** epiretinal, microarray, microfabrication, photoreceptor, polydimethylsiloxane (PDMS), retinal prosthesis.

**For further information contact Courtney Davidson (925) 423-7168 (davidson4@llnl.gov).**

# Maglev on the Development Track for Urban Transportation

**T**HE Inductrack magnetic levitation (maglev) system, conceived by Livermore physicist Richard Post as a safer, cheaper, and simpler means to levitate urban and high-speed trains, is moving down the development track on the way to a full-scale demonstration. Using unique configurations of powerful, permanent magnets, called Halbach arrays, to create its levitating fields, Inductrack is under development by General Atomics (GA) in San Diego. The project is sponsored by the federal government to showcase a new generation of urban transportation technology. Recently, GA and Catherine Elizondo

of Livermore's Industrial Partnerships and Commercialization Office have signed a licensing agreement for use of the levitation technology in Magnetic Levitation Train and Transit Systems.

Inductrack was conceived by Post in the mid-1990s as a new type of maglev technology, one that would use Halbach arrays located on the underside of train cars. (See *S&TR*, June 1998, pp. 20–22.) The magnetic fields generated by these arrays interact with a track composed of shorted circuits to create levitating and centering magnetic forces. The system is fail-safe upon loss of power, and simpler and lower in cost than current maglev systems.

The Inductrack concept for mass transportation was first demonstrated at Livermore in 1998 with a subscale model using a 22-kilogram levitated test cart and a 20-meter-long track. Early Inductrack work was funded by the Laboratory Directed Research and Development Program. The tests were so successful that the National Aeronautics and Space Administration (NASA) awarded the Laboratory a contract to study the technology as a means to help launch rockets into space. The rockets would be sent up an inclined slope to about Mach 0.8 before firing. Post's team built a second test track to investigate the rocket-launch idea; the track was shipped to a NASA contractor this year. The Inductrack will be set up and tested by engineering graduate students at the Florida Space Institute, which is a technical training institution for NASA.

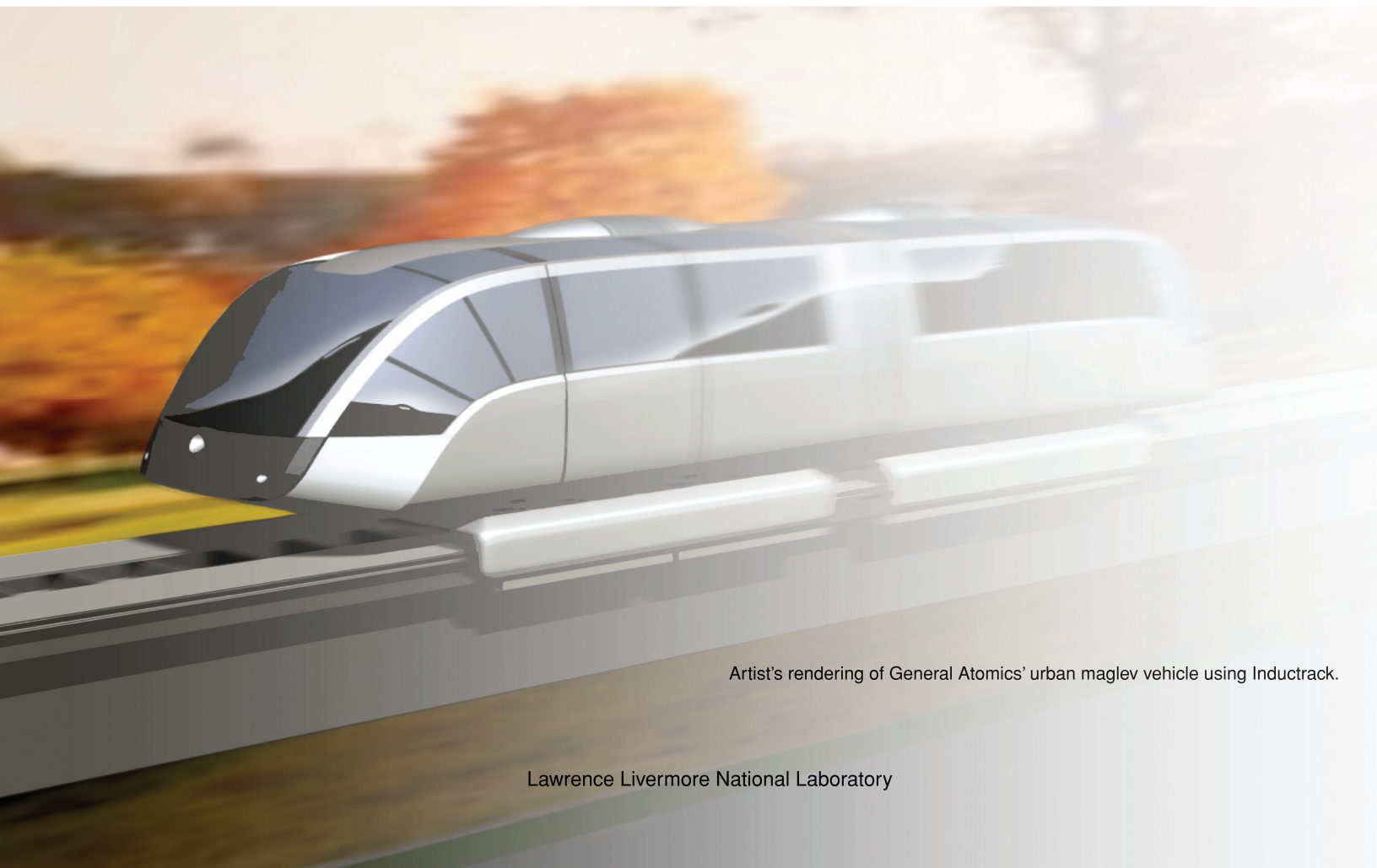

Artist's rendering of General Atomics' urban maglev vehicle using Inductrack.





In May 2003, General Atomics broke ground on a 120-meter-long Inductrack test track, which will feature both straight and curved sections.

In 2000, GA won a contract from the Federal Transit Administration's Low-Speed Urban Maglev Program to develop magnetic levitation technology that would be cost-effective, reliable, and an environmentally sound option for urban mass transportation. GA concluded that Inductrack was the levitation approach that best met its needs, based on factors such as simplicity, weight, capital and maintenance costs, and design flexibility. Sam Gurol, General Atomics program manager, notes that GA has worked with Livermore scientists, including Post, for years on a variety of research projects, most of them related to magnetic fusion.

Studies at GA, Livermore, and other institutions have shown that a maglev system using Inductrack offers many benefits, including its ability to operate in all weather conditions and in terrain with steep grades and tight turns, its low maintenance, and its rapid acceleration. Also, its quiet operation allows elevated tracks to run through neighborhoods, thereby eliminating the need to tunnel underground for noise abatement. For many urban environments, the maglev system can result in significant cost savings over conventional transportation systems.

### Full-Scale Test Track under Construction

In May 2003, GA broke ground at its San Diego facility on a 120-meter-long, full-scale test track, which will feature both straight and curved (50-meter radius) sections. In June, a test vehicle consisting of a single, full-scale chassis unit (a mass transit vehicle has two chassis units) was shipped to GA from Hall Industries in Pennsylvania. The vehicle chassis is composed of upper and lower Halbach arrays, additional Halbach magnet arrays for the propulsion system, auxiliary wheels, and secondary suspension components.

The test vehicle's chassis is equipped with water tanks for varying the weight during the test. The initial tests will be conducted on the first 15 meters of the test track. Once the entire 120-meter track is completed, the test vehicle will be operated (remotely) at speeds sufficient for levitation.

"The purpose of the test track is to validate integrated levitation, propulsion, and guidance," says Gurol. "Each of these has already

been successfully demonstrated individually." Upon successful completion of trials, GA hopes to construct a demonstration system at California University of Pennsylvania in California, Pennsylvania.

Post notes that the concept of magnetically levitated trains, based on other technological approaches, has been studied in several nations for decades. "Demonstration systems in Germany and Japan, while impressive for the high speeds they attained, have proven to be both technically complex and unusually demanding from an engineering standpoint. What's more, they have a high capital cost and are difficult to maintain and to operate safely."

For example, the Japanese maglev system requires costly cryogenic equipment to cool its superconducting coils and must accelerate to speeds exceeding 100 kilometers per hour before it levitates. Also, passengers must be shielded from the high



General Atomics' full-scale Inductrack test vehicle on the first section of the test track.

magnetic fields generated by its superconductors. The German maglev uses an electromagnetic design, which is based on magnetic attraction rather than repulsion and requires control systems to maintain a stable air gap of less than 10 millimeters. A breakdown of the magnet control circuits or cryogenic systems could lead to a sudden loss of levitation while the train is moving.

### Permanent Magnets Mean Fail-Safe Operation

Unlike the German and Japanese maglevs, no on-board power is required to generate Inductrack's levitating magnetic fields because it uses permanent magnets. The permanent magnets also ensure fail-safe operation. If the system were to lose power, the train would remain stably levitated until it slows to walking speeds, at which point it would settle down on auxiliary wheels. Also, the use of permanent-magnet Halbach arrays allows a 2.5-centimeter air gap between them and the levitated train car. Such a large gap has advantages in foul weather and permits the construction of tracks with looser tolerances.

Post says engineers rejected using permanent magnets for maglev systems decades ago because the lifting forces developed by the magnets were not powerful enough relative to their

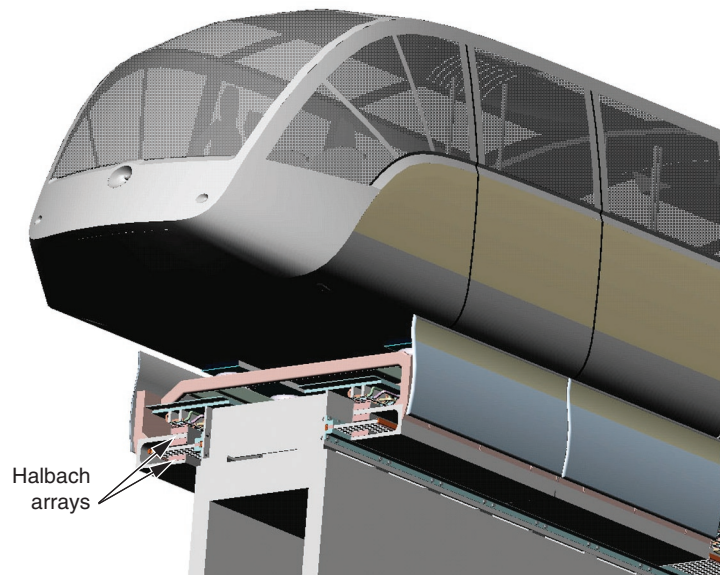

Drawing of the front end of urban maglev vehicle showing the vehicle's levitation/propulsion module. Dual Halbach arrays of permanent magnets are positioned under the train car to provide the levitating force.

weight. That situation was changed by two developments. First, the theoretical analyses in the 1980s conducted by physicist Klaus Halbach of Lawrence Berkeley National Laboratory resulted in his invention of the Halbach array. Originally intended for use in particle accelerators for focusing and controlling particle beams, the Halbach array is a special configuration of permanent magnets. Each bar is at right angles to adjacent bars so that magnetic field lines combine to produce a strong field below the array and cancel out one another above the array.

Second, at about the same time as the Halbach arrays were conceived, permanent magnets made of an alloy of neodymium, iron, and boron were developed and put into large-scale production for such applications as computer hard drives. Because they have a much higher magnetic field than other permanent magnets, neodymium-iron-boron magnets substantially enhanced the value of Halbach's invention.

Inductrack features a Halbach array of permanent magnets positioned under a train car. The cars ride on a track of ladderlike construction consisting of closely spaced "rungs" composed of tightly packed bundles of insulated wire (litz wire). The conductors of each rung are connected at both ends into a common bus bar, thereby forming an array of shorted circuits. When the train starts to move, the magnets induce electrical currents in the track's circuits. These currents produce a magnetic field that repels the array, thus levitating the train car. This repulsive force lifts the cars 2.5 centimeters or more above the track's surface.

As long as the train is moving above a few kilometers per hour, a bit faster than walking speed, the car will be levitated by the motion-induced currents and their resulting magnetic field. The train will run on auxiliary wheels along rails until it reaches the transition speed, at which point it will begin levitating. If the power suddenly fails, the train cars remain levitated while slowing down to a low speed, at which point the cars come to rest on their wheels.

### Inductrack II Doubles Magnetic Field

After the first Inductrack system was tested, Post introduced Inductrack II, which features dual Halbach arrays straddling the track to nearly double the magnetic field. Inductrack II, which is the design used by the GA urban maglev system, requires half the current to achieve the same levitation force per unit area as that required when using the single-sided Inductrack I configuration, without substantially increasing the weight or footprint area of the Halbach arrays. Inductrack II thus has lower drag forces (higher levitation efficiency) at low speeds than Inductrack I, an important asset for an urban maglev system.

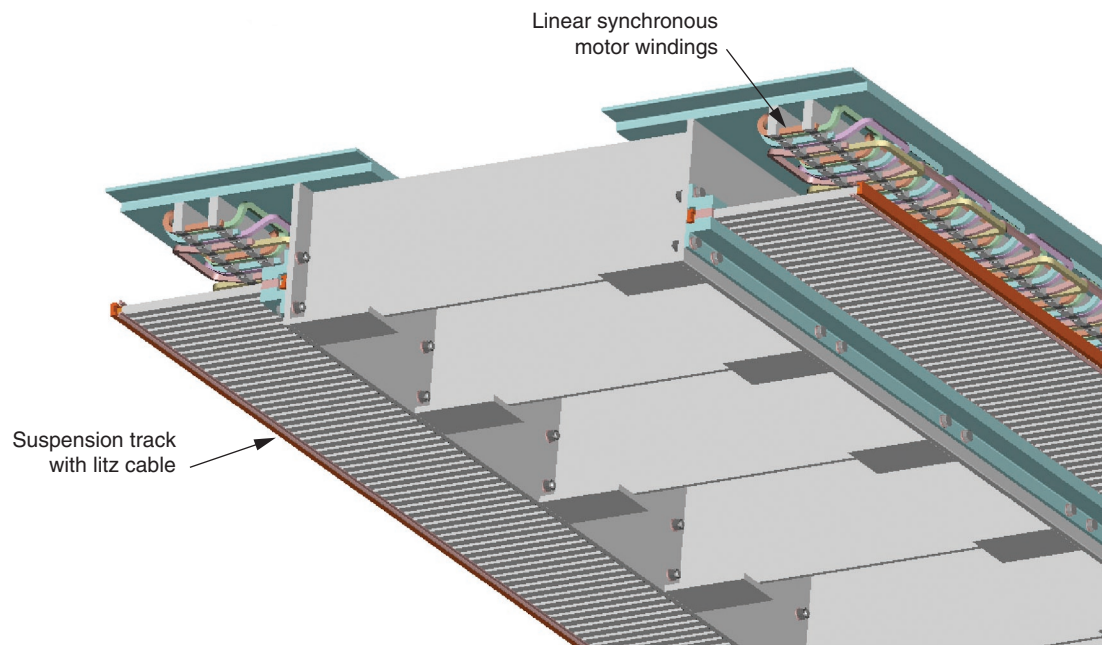

Schematic of General Atomics' test track showing motor windings embedded in the track. The windings are used with a linear synchronous motor to power and brake the train. Train cars ride on a track of ladderlike construction (suspension track) consisting of closely spaced "rungs" composed of tightly packed bundles of insulated wire (litz wire). When the train starts to move, the magnets induce electrical currents in the track's circuits that produce a magnetic field. This magnetic field repels the array, thus levitating the train car 2.5 centimeters above the track.

With Inductrack, the train needs only a source of drive power to accelerate it to levitating speed, keep it powered, and provide braking. GA has selected an energy-efficient, linear synchronous motor composed of a separate Halbach array underneath the train car that interacts with motor windings embedded in the track.

Analyses by Post and Dmitri Ryutov at Livermore and colleagues at GA and Carnegie Mellon University show Inductrack has an important advantage over other maglev systems: Its performance can be analyzed theoretically with a high degree of confidence. The theory has been compared against subscale test results and then incorporated in simulation codes. These codes can be used to design full-scale systems without the need for expensive and time-consuming tests and modifications as was the case for German and Japanese demonstration maglev systems.

Theoretical analyses show that, if required by the application, Inductrack systems can be designed to levitate more than 40 metric tons per square meter of Halbach array, with up to 50-to-1 ratio of levitated weight of a train car to magnet weight. These levitation forces are close to the theoretical maximum that can be exerted by permanent magnets. Actual values achieved in a test run at GA are about 30 metric tons per square meter, in close agreement with the theoretically predicted levitation force for the configuration that was tested.

Inductrack's first commercial application is expected to be for an urban train transport system. Other potential applications include intercity high-speed trains, people movers, high-speed intercity shipment of high-value freight in "pods" that would be levitated in evacuated tubes, and maglev-assisted launching of rockets carrying satellites.

While work on the demonstration effort proceeds in San Diego, the Livermore team is optimizing the design of the magnets and the track. In particular, the team is working on a novel laminated track composed of a stack of slotted sheets of copper reinforced by fiber composite. The new design is simpler and should be lower in cost to manufacture than the litz-wire ladder track.

Safer, simpler, and cheaper than other designs, Inductrack increasingly appears to be the right track to the future of urban transportation systems.

—Arnie Heller

**Key Words:** Halbach array, high-speed train, Inductrack, magnetic levitation (maglev), permanent magnets, urban transportation.

**For further information contact Dick Post (925) 422-9853 (post3@llnl.gov).**



# Power Plant on a Chip Moves Closer to Reality

**A**S yet, no battery in a laptop will last on a round-trip, coast-to-coast flight. Ditto for heavily used cell phones on a cross-country road trip. The comparatively short life of batteries and fuel cells is also an issue for the military, weapons-testing monitors, and the intelligence community.

But all that may be on the verge of changing. A team from the Laboratory's Chemistry and Materials Science Directorate and the Center for Microtechnology Engineering has been working for the past several years on a tiny device that can process minute amounts of fuel, such as hydrogen from methanol and water, to in turn feed a miniature fuel cell for powering unattended sensor systems and eventually consumer electronics.

## Power Hungry

We all get annoyed when our flashlights or handheld devices run low on juice. But it's a much more serious matter when the

electrical item in question is a sensor being used for remote military reconnaissance, intelligence gathering, or telemetry. Unattended sensor systems being developed for use by the military and homeland security require longer-lasting power sources than are currently available. Lawrence Livermore researcher Ravi Upadhye explains, "If you place a sensor for military or intelligence purposes, many times you cannot get back to it to renew the power. So not only does the sensor need to use very little power, but the power source also needs to last a long time."

The team's initial objective was to create a small power source that could generate about 500 milliwatts, or half of a watt, and operate at least three times longer than current rechargeable batteries. "We exceeded our objective by more than a factor of 10," says Upadhye. "A cell phone needs about 2 to 3 watts; we can keep one running with a single fuel cell for nearly 12 hours on a charge from about 25 milliliters of a methanol-water mixture."

Fuel processor development team members (left to right): Jeff Morse, Ravi Upadhye, Tim Graff, Dave Sopchak (holding the dime-size processor), Mark Havstad, and Alan Jankowski.

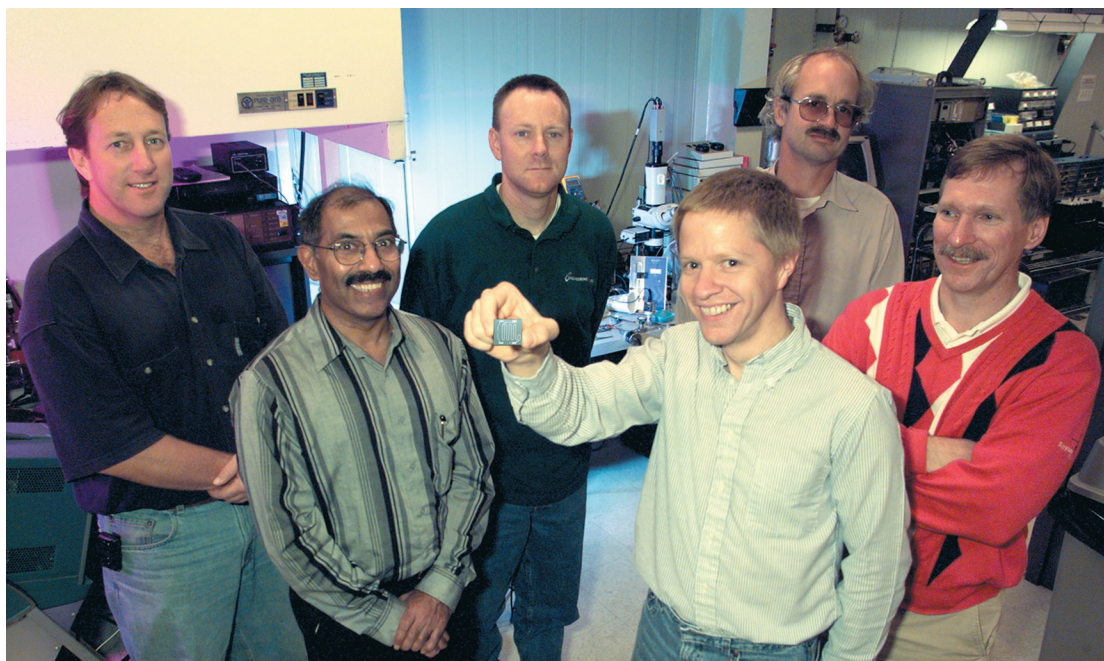

## Making It Work

Fuel cells store energy in the form of an external fuel, rather than as an integrated part of the structure of the device, such as is in batteries. (See the [box on p. 20](#).) Upadhye led a team of chemists and engineers on a recently completed three-year Laboratory Directed Research and Development project to create a thermally robust, dependable microfluidic fuel processor that could be integrated into a Livermore-designed fuel cell system. The team successfully developed a dime-sized processor that converts methanol into hydrogen, which is used to power a thin-film fuel cell.

Methanol conversion to hydrogen was chosen because these new types of fuel cell systems need to operate from high-energy-density liquid fuels in order to stay small and reach the level of energy densities required. Schemes based on nickel-cadmium (ordinary batteries) don't provide much energy for the volume and weight taken up by the elements. Lighter-weight hydrogen could be used directly, but it does not provide the high energy densities required. Livermore's unique approach is to use a silicon micromachined catalytic fuel processor to convert high-energy-density hydrocarbon fuel (that is, methanol or butane) to hydrogen. Fifty milliliters of a fuel composed of 67 percent methanol in water now yields about 27 hours of "talk time" on a cell phone, or one to two months on standby.

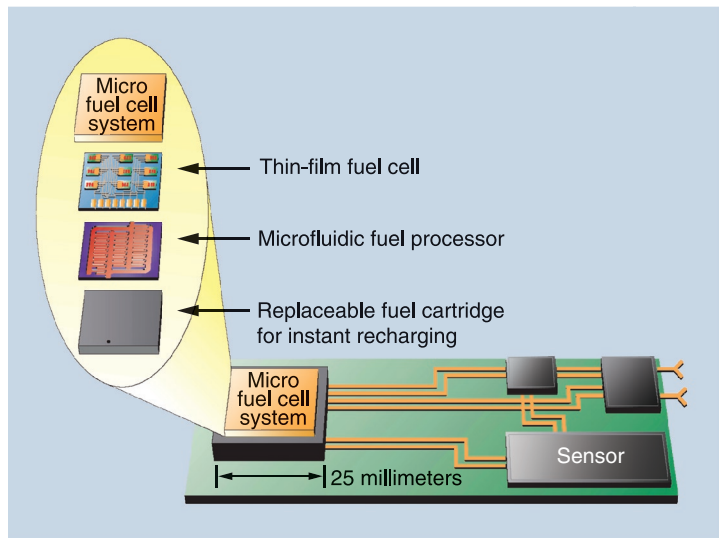

This micro fuel cell system includes a Laboratory-designed microfluidic fuel processor that converts methanol and water (from a replaceable fuel cartridge) into hydrogen to power the thin-film fuel cell.

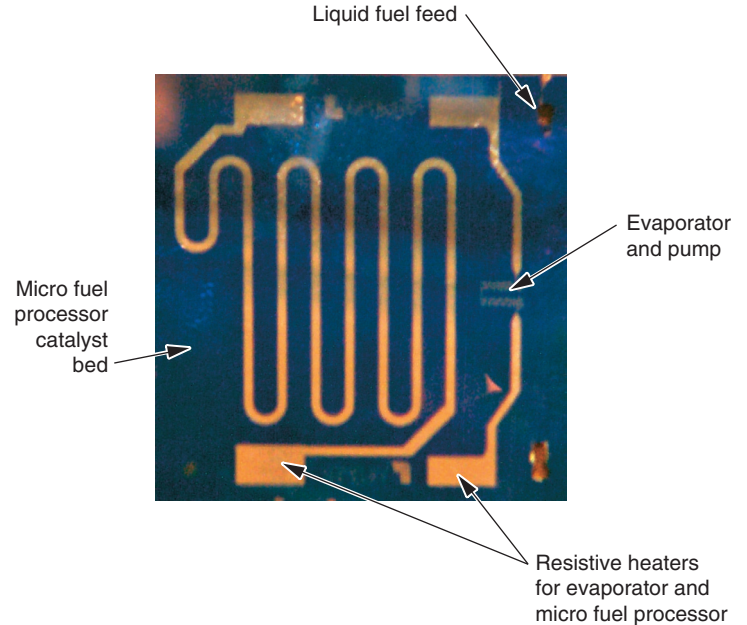

The dime-size fuel processor, up close, showing the various components. A methanol-water fuel is fed into the liquid fuel feed; tiny heaters heat the methanol mixture to produce hydrogen gas, carbon dioxide, and a small amount of carbon monoxide. The hydrogen fuel and ambient oxygen are delivered to the fuel cell manifold by microfluidic interconnects.

The 25-millimeter-square fuel processor is separate from the proton-exchange-membrane (PEM) fuel cell. The processor uses a reaction called steam reforming, in which a mixture of water and methanol snakes through microchannels the size of a human hair and coated or filled with a catalyst. When heated to nearly 300°C, the steam and methanol mixture reforms into hydrogen gas, carbon dioxide, and a small amount of carbon monoxide. The hydrogen fuel travels through microfluidic interconnects to the fuel cell manifold. Once in the fuel cell itself, the hydrogen combines with oxygen from the ambient air to produce electricity and water vapor. The entire steam-reforming reaction is sustained with only minimal power. The fuel processor, notes Upadhye, provides an integrated solution that solves the issues of fuel storage, processing, and delivery.

Over the past couple of years, Upadhye and the team successfully addressed a number of key technical issues. They simulated the reacting flow in the fuel processor to assist in the understanding and development of different processor designs. (See *S&TR*, [December 2001](#), pp. 4–11.) They made significant

## Fuel Cell Basics

Take a simple physics experiment: send an electric current through water to split the water into hydrogen and oxygen components. Now, run that experiment backwards. Combine hydrogen and oxygen—the result? Water and electricity. Such was the reasoning of Sir William Grove, a British attorney and physicist in the mid-1800s. In 1839, he put this reasoning into the design of his gas voltaic battery, which is acknowledged today as the first fuel cell. And even though other fuels have been used—in 1889, for instance, chemists Ludwig Mond and Charles Langer attempted to build the first practical fuel cell using air and industrial coal gas—hydrogen-based fuel cells remain the primary focus of efforts to make small, practical fuel cells.

Fuel cells are electrochemical devices that convert the energy released by a chemical reaction directly into electrical energy. In a typical fuel cell, a gaseous fuel, such as hydrogen, is fed to the anode. At the same time, an oxidant, such as oxygen from the air, is fed continuously to the cathode. The fuel and oxygen meet at the electrodes, and the electrochemical reaction occurs. The resulting electrical current is delivered through current collectors.

Fuel cells are akin to batteries, but different in some fundamental ways. They have many components in common—

anodes, cathodes, and so on. And like batteries, fuel cells can be connected together in series to produce higher voltages. However, a battery stores its energy internally and has a fixed amount of material available for conversion to electricity. Once that material is depleted, the battery is useless or must be recharged. In a fuel cell, the fuel is stored outside the cell itself. Hence, a fuel cell has no fixed capacity—it will generate electricity as long as it is supplied with fuel and air.

Fuel cells can accept almost any kind of fuel, including gases such as hydrogen and methane, liquids such as gasoline, and solids such as carbon. Once connected to a fuel supply, a cell will produce electricity until its supply is removed or exhausted.

Fuel cells have been used in spacecraft and military applications for years. Livermore researchers are developing a number of types of fuel cells for different applications, including solid-oxide fuel cells (*S&TR*, September 2002, pp. 17–19), carbon conversion fuel cells (*S&TR*, June 2001, pp. 4–12), and the fuel cells described in this article, which use a proton-exchange membrane to combine oxygen and hydrogen to create electricity and water—a direct descendant of Grove's first fuel cell.

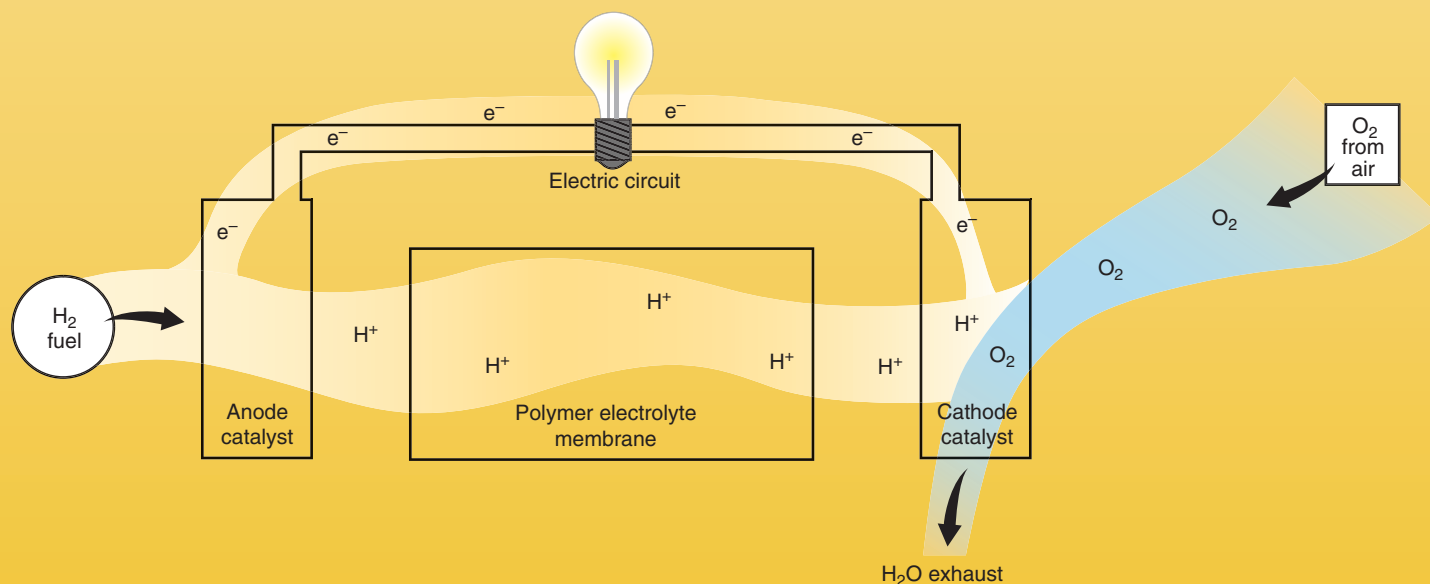

Anatomy of a micro fuel cell. The fuel cell looks like a sandwich, with the cathode and anode acting as bread to the electrolyte filling. Air (O<sub>2</sub>) is drawn in through the cathode, and a gaseous fuel such as hydrogen (H<sub>2</sub>) is drawn in through the anode. The cathode and anode (collectively called electrodes) are typically made of graphite or some other form of carbon. As the hydrogen passes through the catalyst, an electron (e<sup>-</sup>) is stripped from each hydrogen atom. The hydrogen ions can then travel through the proton-exchange membrane. The electrons, meanwhile, travel through a circuit, creating an electric current. Electrons, hydrogen ions, and oxygen from the air all end up on the same side of the membrane, where they combine, producing water vapor (H<sub>2</sub>O). The result: clean electricity and water. (*Adapted courtesy of Fuel Cells 2000, [www.fuelcells.org](http://www.fuelcells.org).*)



advances by depositing sputter-coated nickel and copper-oxide catalysts onto the fuel processor's microchannels. A key objective—to obtain a high conversion of methanol to hydrogen—was met in 2003 when the team built a prototype that obtained almost complete conversion of methanol at about 270°C.

Some challenges still remain, including finding better ways to lessen the production of carbon monoxide, which poisons the fuel cell's PEM. The team, using a commercially available Preferential Oxidation or Prox catalyst, has eliminated the carbon monoxide in the fuel cell feed. They are developing a better catalyst that will lower the surface temperature of the fuel processor package to 40°C or less for military and consumer applications.

“Surface temperature is important for several reasons. For reconnaissance and intelligence gathering, a device that's hot enough to show up on heat-sensitive detectors is not acceptable,” says Upadhye. “And consumers would get nervous carrying an obviously warm device around in their pocket or purse. We don't want to add a lot of insulation, because that runs counter to the objective of keeping this power source small and compact. So we are exploring ways to lower the temperature of the reaction. We are also developing a vacuum packaging design for the fuel processor system.”

### More Power in the Future

Although still experimental, the micro fuel cell project has drawn outside interest, and a Cooperative Research and Development Agreement is now in place with a company that has licensed the technology. Engineer Jeff Morse, head of the fuel cell project, explains, “We've developed fuel processors for easy storage of liquids such as methanol or butane. Those liquids can then be converted into hydrogen, which is notoriously difficult to store in any form. We now have a power plant on a chip that can be used for a variety of purposes, military and commercial.”

Upadhye adds, “Laptops need 10 to 15 watts, and we're working on reaching that threshold now. Someday, there will be a fuel cell that will, for instance, allow a laptop to run for days and days. Only a spare methanol cartridge, about the size of a cigarette lighter, will be needed to plug in when the first one goes empty. That day is not too far away.”

—Ann Parker

**Key Words:** Center for Microtechnology Engineering, fuel reactor, fuel reforming, hydrogen, methanol, micro fuel cell, micro fuel processor, microscale power source, proton-exchange membrane (PEM).

**For further information contact Ravi Upadhye (925) 423-1299 (upadhye1@llnl.gov).**

*Continued from p. 2*

### **First JASPER gas-gun shot on target**

On July 8, 2003, the Laboratory achieved a major milestone with the firing of the JASPER gas gun at the Nevada Test Site. “The JASPER team successfully executed our first plutonium shot today at 2:35 p.m.,” said Mark Martinez, test director. “The data demonstrate superb quality, and a preliminary analysis indicates that JASPER will meet its intended goal of generating high-precision plutonium data.”

Livermore scientists fired a tantalum projectile at more than 5 kilometers per second at a plutonium target. The impact produced a high-pressure shock wave that passed through the target in a fraction of a microsecond. During this extremely brief period, diagnostic equipment measured the properties of the shocked plutonium inside the target. These shock physics experiments complement the ongoing subcritical experiments at the Nevada Test Site.

JASPER, an acronym for Joint Actinide Shock Physics Experimental Research, is a 20-meter-long, two-stage gas gun. It was built and activated at a total cost of \$20 million inside existing facilities within Area 27 at the Nevada Test Site.

Inside the gun’s first stage, hot gases from a burning propellant drive a heavy piston down a pump tube, compressing a gas. That gas—typically hydrogen—builds up to extremely high pressures, breaks a valve, and enters the narrower barrel of the second stage, propelling the projectile housed in the barrel toward the target. JASPER can fire small projectiles at velocities of up to 8 kilometers per second, which is more than 24 times the speed of sound.

The gas gun completed a series of 20 inert or nonnuclear shots to qualify it for use with nuclear materials. This first plutonium shot marks the culmination of years of effort in facility construction, gun installation, system integration, design reviews, and authorizations to bring the experimental facility on line. The gun can fire about 24 experiments per year.

Following this landmark experiment, Linton Brooks, administrator for the National Nuclear Security Administration, concluded, “Our national laboratories now have at their disposal a valuable asset that enhances our due diligence to certify the nuclear weapons stockpile in the absence of underground nuclear weapons testing.”

**Contact: Neil Holmes (925) 422-7213 ([holmes4@llnl.gov](mailto:holmes4@llnl.gov)).**

*Each month in this space we report on the patents issued to and/or the awards received by Laboratory employees. Our goal is to showcase the distinguished scientific and technical achievements of our employees as well as to indicate the scale and scope of the work done at the Laboratory.*

## Patents

---

### **Bonded, Walk-Off Compensated Optical Elements**

**Christopher A. Ebbers**

U.S. Patent 6,544,330 B2

April 8, 2003

A bonded, walk-off compensated crystal, for use with optical equipment and methods of making optical components.

### **Solid-State Microrefrigerator**

**Joel N. Ullom**

U.S. Patent 6,581,387 B1

June 24, 2003

A normal-insulator-superconductor (NIS) microrefrigerator in which a superconducting single crystal is both the substrate and the superconducting electrode of the NIS junction. The refrigerator consists of a large, ultrapure superconducting single crystal and a normal metal layer on top of the superconducting crystal, separated by a thin insulating layer. The superconducting crystal can be either cut from bulk material or grown as a thick epitaxial film. The large, single superconducting crystal allows quasiparticles created in the superconducting crystal to easily diffuse away from the NIS junction through the lattice structure of the crystal to normal metal traps, preventing the quasiparticles from returning across the NIS junction. The invention provides orders of magnitude larger cooling power than thin-film NIS microrefrigerators. The superconducting crystal can serve as the superconducting electrode for multiple NIS junctions to provide an array of microrefrigerators. The normal electrode can be extended, and micros supports provide support and cooling of sensors or arrays of sensors.

### **X-Ray Shearing Interferometer**

**Jeffrey A. Koch**

U.S. Patent 6,590,954 B1

July 8, 2003

An x-ray interferometer for analyzing high-density plasmas and optically opaque materials includes a pointlike x-ray source for providing a broadband x-ray source. The x rays are directed through a target material and then are reflected by a high-density, ellipsoidally bent imaging crystal to a diffraction grating disposed at  $1\times$  magnification. A spherically bent imaging crystal is used when the x rays that are incident on the crystal surface are normal to that surface. The diffraction grating produces multiple beams that interfere with one another to produce an interference pattern, which contains information about the target. A detector is disposed at the position of the image of the target produced by the interfering beams.

### **Ultrasound Image-Guided Acetabular Implant Orientation during Total Hip Replacement**

**John Chang, Waleed Haddad, Jan-Ulco Kluiwstra, Dennis Matthews, Kenneth Trauner**

U.S. Patent 6,607,487 B2

August 19, 2003

A system for assisting in precise location of the acetabular implant during total hip replacement. The system uses ultrasound imaging for guiding the placement and orientation of the implant.

### **Metal-Doped Organic Gels and Method Thereof**

**Joe H. Satcher, Jr., Theodore F. Baumann**

U.S. Patent 6,613,809 B2

September 2, 2003

A sol-gel polymerization process for synthesizing metal-doped organic gels. The process polymerizes metal salts of hydroxylated benzenes or hydroxylated benzene derivatives with alkyl or aryl aldehydes to form metal-doped, wet, organic gels. The gels can then be dried by supercritical solvent extraction to form metal-doped aerogels or by evaporation to form metal-doped xerogels. The aerogels and xerogels can then be pyrolyzed.

### **Semiconductor Material and Method for Enhancing Solubility of a Dopant Therein**

**Babak Sadigh, Thomas J. Lenosky, Tomas Diaz de la Rubia, Martin Giles, Maria-Jose Caturia, Vidvuds Ozolins, Mark Asta, Silva Theiss, Majeed Foad, Andrew Quong**

U.S. Patent 6,617,228 B2

September 9, 2003

A method for enhancing the equilibrium solubility of boron and indium in silicon. The method involves first-principles quantum mechanical calculations to determine the temperature dependence of the equilibrium solubility of two important *p*-type dopants in silicon, namely boron and indium, under various strain conditions. The equilibrium thermodynamic solubility of size-mismatched impurities, such as boron and indium in silicon, can be raised significantly if the silicon substrate is strained appropriately. For example, for boron, a 1-percent compressive strain raises the equilibrium solubility by 100 percent at 1,100°C, and for indium, a 1-percent tensile strain at 1,100°C enhances solubility by 200 percent.

### **Miniature Laser Tracker**

**Charles S. Vann**

U.S. Patent 6,618,132 B1

September 9, 2003

This small, inexpensive, noncontact laser sensor can detect the location of a retroreflective target in a relatively large volume and up to 6 degrees of position. The tracker's laser beam is formed into a plane of light, which is swept across the space of interest. When the beam illuminates the retroreflector, some of the light returns to the tracker. The intensity, angle, and time of the return beam is measured to calculate the three-dimensional location of the target. With three retroreflectors on the target, the locations of three points on the target are measured, enabling the calculation of all 6 degrees of target position.

Until now, devices for three-dimensional tracking of objects in a large volume have been heavy, large, and expensive. Because of the simplicity and unique characteristics of this tracker, it is capable of three-dimensional tracking of one to several objects in a large volume; yet, it is compact, lightweight, and relatively inexpensive. Alternatively, a tracker produces a diverging laser beam that is directed toward a fixed position and senses when a retroreflective target enters the fixed field of view. An optically bar-coded target can be read by the tracker to provide information about the target. The target can be formed from a ball lens with a bar code on one end. As the target moves through the field, the ball lens causes the laser beam to scan across the bar code.



**CO<sub>2</sub> Laser and Plasma Microjet Process for Improving Laser Optics****Raymond M. Brusasco, Bernardino M. Penetrante, James A. Butler, Walter Grundler, George K. Governo**

U.S. Patent 6,620,333 B2

September 16, 2003

An optic is produced for operation at the fundamental neodymium-doped yttrium–aluminum–garnet (Nd:YAG) laser wavelength of 1.06 micrometers through the tripled Nd:YAG laser wavelength of 355 nanometers using a method to reduce or eliminate the growth of laser damage sites in the optics. The optics are processed to stop the damage from growing to a predetermined critical size. A system is provided for mitigating the growth of laser-induced damage in optics by virtue of localized removal of glass and absorbing material.

**Method to Produce Alumina Aerogels Having Porosities Greater Than 80 Percent****John F. Poco, Lawrence W. Hrubesh**

U.S. Patent 6,620,458 B2

September 16, 2003

A two-step method for producing monolithic alumina aerogels having porosities of greater than 80 percent. Strong, low-density alumina aerogel monoliths are prepared using the two-step sol-gel process. The method of preparing pure alumina aerogel modifies the previously known sol method by combining the use of substoichiometric water for hydrolysis, acetic acid to control hydrolysis and condensation, and high-temperature supercritical drying, all of which contribute to the formation of a polycrystalline aerogel microstructure. This structure gives the alumina aerogel exceptional mechanical properties as well as enhanced thermal resistance and high-temperature stability.

**Ultrashort-Pulse Laser Machining of Metals and Alloys****Michael D. Perry, Brent C. Stuart**

U.S. Patent 6,621,040 B1

September 16, 2003

A method for high-precision machining (cutting, drilling, sculpting) of metals and alloys. Pulses in the 10-femtosecond to 100-picosecond range allow for extremely precise machining essentially without producing any heat- or shock-affected zones. Because the pulses are so short, negligible thermal conduction exists beyond the region removed. This results in negligible thermal stress or shock to the material beyond approximately 0.1 to 1 micrometer (dependent upon the particular material) from the laser-machined surface. Because of the short duration, the high intensity associated with the interaction converts the material directly from the solid state into an ionized plasma. Hydrodynamic expansion of the plasma eliminates the need for ancillary techniques to remove material and produces extremely high-quality machined surfaces with negligible redeposition either within the kerf or on the surface. Because heating is negligible beyond the depth of material removed, the composition of the remaining material is unaffected by the laser machining process. Thus, alloys and even pure metals can be machined with high precision with no change in the material's grain structure.

### When Semiconductors Go Nano

Following several years of quantum Monte Carlo simulations and spectroscopic and x-ray absorption experiments to explore the properties of silicon and germanium at the nanoscale, Livermore recently began examining nanodiamond as well. In the first-ever computational modeling of the optical properties of nanodiamonds, researchers made a surprising discovery. Unlike silicon and germanium, whose surfaces reconstruct to compress the particle's core at the nanoscale, the surface of nanodiamond expands into the shape of a fullerene. Livermore is interested in these materials primarily because of the possibility of their use in detectors for biological and chemical warfare agents. Other uses include photon switches, tunable lasers, nanocrystal solar cells, and perhaps as next-generation targets for the National Ignition Facility.

**Contact:**

**Tony van Buuren** (925) 423-5639 ([vanbuuren1@llnl.gov](mailto:vanbuuren1@llnl.gov)) or

**Giulia Galli** (925) 423-4223 ([galligygi1@llnl.gov](mailto:galligygi1@llnl.gov)).

# Designing a Large-Scale X-Ray Laser

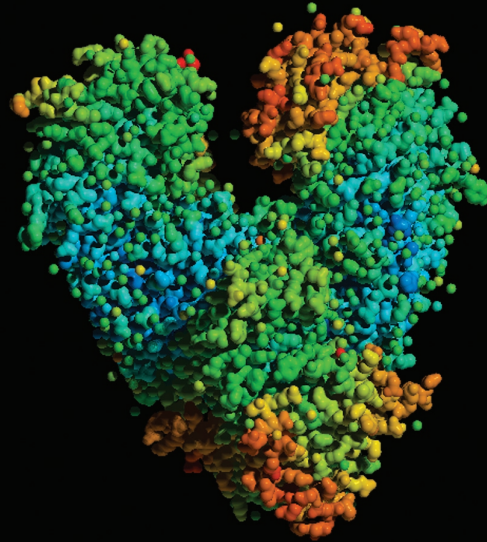

A new x-ray laser with record-shattering brightness will revolutionize the imaging of proteins, viruses, and other biological materials.

#### **Also in December**

- *Proton beams created by powerful, ultrashort pulses of laser light are being used to create and even diagnose plasmas.*
- *Livermore mathematicians are writing codes called scalable linear solvers that keep large computer simulations running fast.*
- *Finding the most stable forms of nitrogen fullerenes, a new type of buckyball, may lead to improved orthopedic implants, new pharmaceuticals, and more stable high explosives.*

Coming Next Month

University of California  
Science & Technology Review  
Lawrence Livermore National Laboratory  
P.O. Box 808, L-664  
Livermore, California 94551

Nonprofit Org.  
U. S. Postage  
**PAID**  
Albuquerque, NM  
Permit No. 853



Printed on recycled paper.