

**BACTERIALLY INDUCED PRECIPITATION OF CaCO₃: AN EXAMPLE
FROM STUDIES OF CYANOBACTERIAL MATS**

FINAL REPORT

APRIL 30, 1990

HENRY S. CHAFETZ

**UNIVERSITY OF HOUSTON
HOUSTON, TEXAS 77204-5503**

DISCLAIMER

This report was prepared as an account of work sponsored by an agency of the United States Government. Neither the United States Government nor any agency thereof, nor any of their employees, makes any warranty, express or implied, or assumes any legal liability or responsibility for the accuracy, completeness, or usefulness of any information, apparatus, product, or process disclosed, or represents that its use would not infringe privately owned rights. Reference herein to any specific commercial product, process, or service by trade name, trademark, manufacturer, or otherwise does not necessarily constitute or imply its endorsement, recommendation, or favoring by the United States Government or any agency thereof. The views and opinions of authors expressed herein do not necessarily state or reflect those of the United States Government or any agency thereof.

APR 1 1992

APRIL 30, 1990

**PREPARED FOR THE U. S. DEPARTMENT OF ENERGY
UNDER GRANT NUMBER DE-FG05-87ER13771**

MASTER

DISTRIBUTION OF THIS DOCUMENT IS UNLIMITED

INTRODUCTION

The primary objectives of this project were to evaluate the role of bacteria in the lithification of cyanobacterial (blue-green algal) mats and to provide criteria so that bacterially induced lithified stromatolites could be recognized in the rock record. In order to accomplish these objectives it was necessary to collect bacteria from modern cyanobacterial mats and culture them in the laboratory. It was then necessary to demonstrate that these bacteria could induce the precipitation of calcium carbonate, document the form of that precipitate, and determine if any of these forms are unique to bacterially induced precipitates. Once this was accomplished, modern cyanobacterial mats were studied to determine if any of these forms of precipitates are present within these mats and to evaluate the role that bacterially induced precipitates play in the lithification of cyanobacterial mats into stromatolites. A last phase of the investigation was to determine if bacterially induced precipitation was responsible for the lithification of ancient stromatolites.

The overwhelming majority of this investigation was performed by Chris Buczynski as his dissertation research under my supervision (PhD awarded May 1990); a copy of the dissertation accompanies this report. The reader, consequently, is referred to the dissertation and the accompanying manuscript (Buczynski and Chafetz) for a more complete description of the main phases of the study and its results (background information, methods, materials, references, etc.), i.e., the description below is primarily an abstract of the information contained in those two documents. In addition to the research which formed the basis of Buczynski's dissertation, other work was performed by Chafetz (e.g., Chafetz, Rush, and Schoderbek, in press) as well as Buczynski, and is reported below

(additional manuscripts are in preparation and will be forwarded when completed).

METHODS

Field

Bacteria were collected from two modern carbonate accumulating areas: (1) Kleberg Point, a marine algal tidal flat in Baffin Bay, Texas, and (2) water-filled depressions in a karstic terrain (adjacent to Fresh Creek) and a freshwater pond (near Ginette Pond) on Andros Island, Bahamas. The samples were returned to the laboratory and cultured with a variety of media and under various conditions in order to induce the precipitation of calcium carbonate. All media, tools, and materials, were sterilized prior to use. Multiple samples were taken from each site. In addition to the samples of bacteria, control samples were collected in both field areas. These were used to insure that the collection techniques did not introduce foreign bacteria into the samples, i.e., non-sediment bacteria did not somehow contaminate the samples.

Stromatolites from the rock record were collected from the Pennsylvanian Panther Seep Formation, San Andres Mountains, New Mexico, and the Cambrian Morgan Creek Limestone, central Texas. In addition, Chaetetes from the Pennsylvanian Hermosa Formation, central Colorado, were investigated to determine if bacterially induced peloids had formed within them analogous to the occurrence of bacterially induced precipitates of peloids in some modern corals.

Laboratory

When the recent samples were returned to the laboratory, mixed cultures of aerobic and facultative bacteria were grown at ambient room temperature (average of 22°C) in both the liquid and gelatinous forms of the

media. In addition, for every experimental run, sterile (non-inoculated) controls were established to insure that: (1) the media and glassware had not been contaminated, and (2) precipitation did not occur in the absence of bacteria.

RESULTS

Mixed cultures of aerobic and facultative bacteria from Baffin Bay, Texas, and from Andros Island, Bahamas, have been grown under controlled conditions in the laboratory. These cultures of bacteria have induced the precipitation of calcium carbonate in almost all the culture media and conditions employed. Precipitation of calcium carbonate did not occur in sterile control experiments which, except for the absence of bacteria, were identical to those in which precipitation did take place.

The aggregate forms of the precipitates can be classified into three categories; rods, spheres, and brushes. Rods and spheres are formed from crystal bundles, brushes appear to be single crystals. Growth of crystals at the ends of the crystal bundles results in dumbbell-shaped aggregates. Continued growth of dumbbells results in hemispherical and/or spherical accumulations.

In the experiments conducted, there does not appear to be a relationship between the form of the individual crystals or crystal bundles and nutrients, temperature, light, aeration, medium viscosity, or bacterial composition. In general, when a particular form of a crystal or crystal bundle is found in a culture, the vast majority of crystals are of the same form.

Both calcite and aragonite are formed under the influence of bacteria in the laboratory. However, the precipitate from any given single culture is either aragonite or calcite, not a mixture of both. The controlling factor

appears to be the availability of ions and, hence, the rate of precipitation. In both laboratory experiments and in nature, this can be mediated by the viscosity of the growth media. If bacteria induce the precipitation of crystalline material in a fluid media, ions can be readily transported to the site of nucleation, precipitation occurs rapidly, and aragonite forms. In viscous media, such as agar or the gelatinous slime secreted in copious quantities by some microbial communities, ionic movement is slow, and, consequently, ion availability is low, thus calcite is produced.

Although there are unique forms of crystals and crystal bundles associated with bacterially induced precipitates, at present it is difficult to use them to identify bacterially induced precipitates in the rock record. The single crystals and the crystal bundles are generally less than 100 microns in maximum dimension, and they are quite susceptible to diagenetic alteration. Such alteration can readily obscure the finer details of the original form of the crystals beyond recognition, although some semblance of that form may remain. So that, although the fine crystalline detail may be lost, the gross shape of the precipitate may remain to signify a bacterially induced origin.

Analyses of incipiently lithified modern cyanobacterial mats indicates that these structures lithify due to bacterially induced precipitation. However, recognition of this fact in the rock record may be difficult to substantiate due to diagenetic alteration of the very finely crystalline bacterially induced precipitates.

This study definitively demonstrates that bacteria from carbonate producing environments are capable of inducing the precipitation of calcium carbonate and that they are probably responsible for the lithification of cyanobacterial mats into stromatolites. Calcium carbonate

which precipitates due to the influence of bacteria undoubtedly has different physical and chemical constraints on the conditions under which they form than either purely abiotically precipitated calcium carbonate or, for that matter, calcium carbonate whose precipitation was due to some other taxa. That is, bacterially induced precipitates can form under conditions in which geologists do not generally expect carbonates to precipitate. This fact alters the models that geologists can refer to in order to explain the timing and environments in which calcium carbonate can precipitate, and consequently, the when, where, and under what conditions porosity is occluded and the migration of fluids affected.

PUBLICATIONS

Manuscripts:

Chafetz, Henry S., Rush, Patrick F., and Schoderbek, David A., *in press*, Pennsylvanian black stromatolites: An ancient analog to modern deposits from the Dead Sea: invited contribution to volume 2 of "Phanerozoic Stromatolites", Monty, C., ed., Springer-Verlag.

Buczynski, Chris, and Chafetz, Henry S., *under review*, Habit of bacterially induced precipitates of calcium carbonate and the influence of medium viscosity on mineralogy, submitted to Jour. Sed. Petrol.

Abstracts:

Buczynski, Chris, and Chafetz, Henry S., 1989, Bacterially induced precipitates of calcium carbonate from algal tidal flats: Internat. Stromatolite Field Conf., Austin, Texas, 1989, p. 44.

Buczynski, Chris, and Chafetz, Henry S., *under review*, Habit of bacterially induced precipitates of calcium carbonate and the influence of medium viscosity on mineralogy: submitted Internat. Sedimentological Congress, Aug. 1990, England.

reprints & abstracts
removed.
ds

CHARACTERISTICS OF BACTERIALLY INDUCED PRECIPITATES OF
CALCIUM CARBONATE FROM THE LABORATORY, AND FROM
CYANOBACTERIAL MATS OF BAFFIN BAY, TEXAS,
AND ANDROS ISLAND, BAHAMAS

A Dissertation
Presented to the
Faculty of the Department of Geosciences
University of Houston

In Partial Fulfillment
of the Requirements for the Degree
Doctor of Philosophy

by
Chris Buczynski
May, 1990

db
Received OSTI
AUG 14 1992

DISTRIBUTION OF THIS DOCUMENT IS UNLIMITED

CHARACTERISTICS OF BACTERIALLY INDUCED PRECIPITATES OF
CALCIUM CARBONATE FROM THE LABORATORY, AND FROM
CYANOBACTERIAL MATS OF BAFFIN BAY, TEXAS,
AND ANDROS ISLAND, BAHAMAS

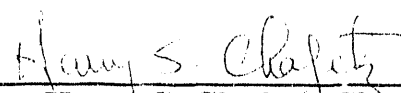

Chris Buczynski

APPROVED:

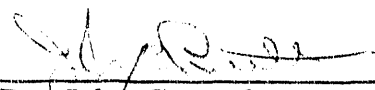
Dr. Henry S. Chafetz, Chairman

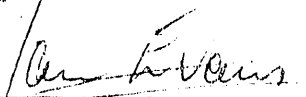
Dr. John C. Butler

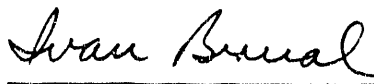
Dr. Ian Evans

Dr. Ivan Bernal

Dean, College of Natural Sciences and Mathematics

ACKNOWLEDGEMENTS

First and foremost, I would like to thank my advisor, H. S. Chafetz, who suggested this research project, outlined some possible approaches, and secured funding to carry it out. Without generous grants (to HSC) from Texaco Oil Company, U. S. A., the U. S. Department of Energy (FG05-87ER13771), and the University of Houston Coastal Center, this project could not have been completed.

Samples from San Salvador, Bahamas, were collected with the permission and assistance of the College Center of the Finger Lakes Bahamian Field Station and its director, D. Gerace. Many other individuals were also generous with their time and expertise. J. Teeter helped procure the use of a shovel in a time and place where they were scarce. E. A. Shinn, R. Ginsberg, J. J. Dravis, B. White, and R. Y. Morita graciously provided samples for examination. H. M. C. Danielli and S. J. Birnbaum taught me basic techniques for culturing bacteria and provided a wealth of information on laboratory supplies.

Many individuals from the U of H Geosciences Department contributed to this project in innumerable ways. My committee members, J. C. Butler, I. Evans and I. Bernal (Chemistry Department), carefully read this dissertation and made suggestions which improved it. I would like to thank P. Rush, and K. Love in particular for their help and company along the way.

CHARACTERISTICS OF BACTERIALLY INDUCED PRECIPITATES OF
CALCIUM CARBONATE FROM THE LABORATORY, AND FROM
CYANOBACTERIAL MATS OF BAFFIN BAY, TEXAS,
AND ANDROS ISLAND, BAHAMAS

An Abstract of a Dissertation
Presented to the
Faculty of the Department of Geosciences
University of Houston

In Partial Fulfillment
of the Requirements for the Degree
Doctor of Philosophy

by
Chris Buczynski
May, 1990

Abstract

Bacteria induce the precipitation of calcium carbonate in the laboratory and in nature by altering their chemical environment. Progressively more geologists are recognizing the possibility that bacterially induced precipitates may form significant mineral deposits, unfortunately, there are currently no sound criteria by which they can be recognized in recent sediments, or in the rock record.

Cultures of aerobic and facultative bacteria from cyanobacterial mats on Andros Island, Bahamas, and Baffin Bay, Texas, induced the precipitation of calcium carbonate under controlled conditions in more than 120 experiments. Controls in all experiments insured that the precipitates were due to bacterial activity.

Crusts, the largest features formed, are composed of 5-200 μ m diameter bundles which are, in turn, composed of numerous individual crystals. The smallest observed features are 0.1-0.4 μ m spheres and rods which comprise some individual crystals and crystal bundles.

Crystal bundles resembling rhombohedra, tetragonal disphenoids, tetragonal dipyramids, and calcite dumbbells appear to be uniquely bacterial in origin, and they have all been observed in recent sediments. Swollen rods, discs, curved dumbbells, and 50-200 μ m optically continuous crystals resembling brushes may be uniquely bacterial in origin, however, they have not been reported by other laboratories nor observed in natural settings. Presence of any of these forms in recent sediments should be

taken as strong evidence for bacterial influence. Spheres and aragonite dumbbells have also been observed in natural environments, however, they are not always bacterial in origin.

The viscosity of the medium appears to be the primary control over mineralogy. In broth media, ionic mobility is high, crystal growth proceeds rapidly, and aragonite is precipitated. In gelatinous media, ionic mobility is lower, crystal growth proceeds more slowly, and calcite precipitates.

Precipitation of calcium carbonate occurs preferentially on dead cyanobacteria in the presence of bacteria. Lithification of algal mats to form stromatolites may take place in the zone of decaying organic matter due to bacterial activity.

Crystal bundles do not often survive diagenesis. Some of the larger spherical forms do survive and they may be recognized by bacterial remains or bacteria-sized voids in their cores, and an average diameter of 10-60um.

Table of Contents

ACKNOWLEDGEMENTS.....	iii
ABSTRACT.....	v
LIST OF FIGURES.....	ix
LIST OF TABLES.....	x
INTRODUCTION.....	1
PREVIOUS WORK.....	7
FIELD AREAS.....	17
METHODS.....	23
FIELD.....	23
LABORATORY.....	25
Media and Culturing Techniques.....	25
Treatment of Field Samples and Laboratory Precipitates...	31
Analytical Techniques.....	34
RESULTS.....	37
PRECIPITATE FORM AND HIERARCHY.....	42
Crystals.....	42
Crystal Bundles and Individual Crystals.....	47
Common Forms.....	47
Unusual Forms.....	56
Submicron-Sized Spherical and Rod-Shaped Components..	66
Factors Influencing Crystal Bundle Forms.....	70

ABIOTIC AND CONTAMINANT PRECIPITATES.....	71
MINERALOGY.....	72
THE ROLE OF CYANOBACTERIA.....	82
GEOCHEMICAL DATA.....	88
Atomic Absorption Data.....	89
Carbon and Oxygen Isotopic Data.....	94
PRECIPITATION IN A SEDIMENT COLUMN.....	97
DISCUSSION.....	100
RECOGNITION OF BACTERIALLY INDUCED PRECIPITATES IN RECENT SEDIMENTS.....	101
RECOGNITION OF BACTERIALLY INDUCED PRECIPITATES IN THE ROCK RECORD.....	103
FACTORS THAT INFLUENCE PRECIPITATE MINERALOGY AND FORM.....	106
AREAS FOR ADDITIONAL RESEARCH.....	108
SUMMARY AND CONCLUSIONS.....	112
APPENDIX OF GEOCHEMICAL DATA.....	118
REFERENCES CITED.....	124
ADDITIONAL REFERENCES.....	147

List of Figures

1	Location map of Kleberg Point, Baffin Bay, Texas.....	18
2A	Location map of Bahamian Islands.....	19
2B	Location map of sampling sites on Andros Island.....	20
2C	Location map of sampling sites on San Salvador.....	21
3	Test tube modified for bacterial culture experiment.....	28
4	Association of precipitate with bacteria on gelatinous media.....	38
5	Hierarchical levels of bacterially induced precipitates.....	43
6	Calcium carbonate crusts.....	45
7	Rod to sphere progression of crystal bundle growth.....	49
8	Various forms and mineralogies of dumbbells.....	51
9	Comparison of laboratory and natural crystal bundles.....	54
10	Bacterially formed discs from the laboratory.....	57
11	A "smooth" dumbbell and swollen rod.....	60
12	Examples of brush crystals.....	62
13	Schematic diagram showing genesis of brush crystals.....	65
14	Calcified bacteria from nature and the laboratory.....	68
15	Inorganic and contaminant precipitates.....	73
16	Aragonite vs. calcite crystal bundles.....	77
17	A crystal bundle which contains dolomite?.....	81
18	Calcification of live vs. dead cyanobacteria in the laboratory.....	84
19	Calcification of live vs. dead cyanobacteria in nature.....	87
20	Plots of grain size vs. elemental composition.....	90

21	Plot of carbon and oxygen isotopic values.....	95
----	--	----

List of Tables

1	Extinction angles of brush crystals.....	67
2	XRD analyses of laboratory precipitates.....	76

INTRODUCTION

Bacteria alter their environment through metabolic processes and, in some cases, this change in the micro-environment immediately surrounding the bacterium becomes conducive to the precipitation of calcium carbonate. Although this fact has been recognized since at least 1903 (Nadson, 1903, from Nadson, 1928), it is only slowly being accepted by the geologic community. Now that this phenomenon is becoming more widely accepted with respect to recent sediments, interest in the extent and importance of bacterially induced precipitation and cementation in the rock record is increasing rapidly. Unfortunately, there are presently no sound criteria to delineate bacterially induced precipitates of calcium carbonate from other types of biotic, and abiotic precipitates. This study was conducted to attempt to define unique characteristics of bacterially induced precipitates of calcium carbonate in order to facilitate their recognition in recent sediments and in the rock record.

In the first stage of the research process, bacterially induced precipitates of calcium carbonate were produced under controlled conditions in the laboratory with cultures of aerobic and facultative bacteria from natural near shore environments associated with filamentous cyanobacterial mats. Cyanobacteria, also known as blue-green algae, cyanophyta, cyanophycophyta, cyanochloronta, myxophyta, or blue green bacteria (Trudinger et al., 1979; Bauld, 1981), should not be confused with "true" bacteria. Various controls insured that the precipitates were,

indeed, formed due to the effects of the bacteria. In the second stage of the research process, the resulting precipitates were examined and characterized based on their morphology and mineralogy. They were then compared to naturally occurring samples collected from San Salvador and Andros Island, Bahamas; Baffin Bay, Texas; and other reported laboratory and natural occurrences to attempt to identify bacterially induced precipitates in recent sediments. Hopefully the completion of these two steps will aid in the ultimate goal of this type of research - to develop criteria by which bacterially induced precipitates of calcium carbonate may be recognized unequivocally in the rock record.

Have bacteria existed in the geologic past, and if so, can the attributes of live bacteria be presumed to be identical or similar to those in the rock record with any certainty? It is imperative that these questions be answered if the type of research proposed above is to be of any value in recognizing bacterially induced precipitates of calcium carbonate in the rock record. In many cases, the present may be the key to the past, but the organisms that lived and thrived in the geologic past are not necessarily living and thriving in the present. However, fossils of bacteria-like forms are found throughout much of the rock record. The oldest "potential" fossils of bacteria are from rocks of the 3.8 billion year old Isua Complex, southwest Greenland, but these are not generally accepted as unequivocal examples of bacteria (Press and Siever, 1982). Examples of what have been identified and generally accepted as bacteria and blue-green algae (cyanobacteria) have been found in stromatolites in the 3.5 billion year old Warrawoona Group,

Northwestern Australia (Dott and Batten, 1971), in the 3.1 billion year old Fig Tree Series, South Africa (Barghoorn and Schopf, 1966), and from the 2 billion year old Gunflint Formation of Ontario (Barghoorn and Tyler, 1965). Golubic and Hofmann (1976, p. 1081) have examined fossil remains of Precambrian cyanophyta and found them "...directly comparable with related extant taxa." and Golubic and Barghoorn (1977, p. 2) have found that "Most Precambrian microbial fossils are comparable with extant 'soft bodied' cyanophytes and bacteria". So, it is fairly well established that bacteria or bacteria-like organisms have existed through a great part of the geologic record and they are at least morphologically similar to present day bacteria. But did ancient bacteria have the same geochemical effect on their environment?

It is not a certainty, but it seems likely that some, if not all, ancient bacteria induced the same general types of geochemical changes in their environments. All bacteria today alter their environment and although they do so by a multitude of different chemical reactions, the basic changes which induce calcium carbonate precipitation can be classified as one of five types (paraphrased from Ehrlich, 1981, p. 105-107): (1) oxidation of carbon compounds under aerobic or anaerobic conditions to release CO_2 , (2) oxidation of nitrogen compounds under aerobic or anaerobic conditions to release NH_3 and CO_2 , (3) reduction of CaSO_4 to CaS , (4) photosynthetic microbial removal of CO_2 , and (5) hydrolysis of urea to form $(\text{NH}_4)_2\text{CO}_3$.

The fourth reaction, removal of CO_2 , can be accomplished photosynthetically by cyanobacteria (although Pentecost, 1978, Pentecost

and Riding, 1986, and Pentecost and Bauld, 1988, feel this is of minor importance) and some bacteria, and nonphotosynthetically by some bacteria (Simkiss and Wilbur, 1989). Ehrlich (1981) believes the fifth reaction to be of minor significance because the necessary urea is generally not present in the marine realm in quantities that would lead to substantial calcium carbonate deposits.

A sixth mechanism involves the ability of both live and dead bacteria to concentrate some elements on their cellular membranes, particularly Ca and Mg (Greenfield, 1963; Carroll et al., 1965; Pautard, 1970; Bronner and Freund, 1972; Takeichi and Okada, 1972; Bronner et al., 1975; Morita, 1980). Because of this localized elemental concentration, the bacteria can act as nuclei for precipitates. In the sense that precipitation would not occur in the absence of the live bacteria or bacterial corpses, even this is considered a form of bacterially induced precipitation for the purposes of this research.

There has been, and still is, a great deal of speculation about the actual individual microbially mediated chemical reactions which lead to the formation of calcium carbonate in the recent. However, the particular chemical pathways by which precipitation is ultimately induced does not, in general, seem to greatly influence the precipitate. The uniformity of the precipitate morphology and mineralogy produced by numerous workers with different strains of marine, soil and contaminant bacteria, mixed cultures, assorted growth media and conditions, through one or more of the six pathways listed above, supports this contention. These facts also support the contention that the precipitation is a passive process in which

the bacteria merely act as a type of "catalyst" to produce an environment where "inorganic" precipitation can take place (McCallum and Guhathakurta, 1970; Friedman and Sanders, 1978, p. 130). Consequently, the form of the precipitate seems to be related to the microenvironment that is created, more so than to the geochemical processes that created the environment or, in many cases, to the particular strain or strains of bacteria used. So although it is clearly impossible to state that ancient bacteria altered their geochemical environment in exactly the same way as recent bacteria, it would seem reasonable to assume that they could and did create microenvironments which could have led to the precipitation of calcium carbonate by one or more of the six general pathways listed above, and that those precipitates probably have modern analogs.

This passive precipitation is distinguished from types of active and purposeful precipitation by other organisms, such as the secretion of shell material by various molluscs or tests by coccolithophorids or foraminifera. There have been no reports of bacteria which are obligate calcifiers in the geologic literature. In fact, rapid precipitation can often entomb a bacterium or a clump of bacteria, much to their dismay, and ultimate demise (Krumbein, 1974; Carroll et al., 1965; McCallum and Guhathakurta, 1970; Deelman, 1975b; Morita, 1980), so not only is it a passive process, it can often be deleterious. Although it has been speculated that algae and bacteria were once possibly protected from ultra violet wavelengths of light by detrital or precipitated carbonates (Fischer, 1965),

this potential mode of "active" precipitation has been convincingly argued against by Gebelein (1976).

PREVIOUS WORK

Numerous workers have suggested and/or demonstrated that bacteria from various environments have the capacity to induce the precipitation of calcium carbonate in the laboratory (Drew, 1911, 1912, 1913, 1914; Kellerman and Smith, 1914; Kellerman, 1915; Berkeley, 1919; Lipman, 1920, 1924, 1929, 1931; Gee, 1932; Gee and Feltham, 1932; Gerundo and Schwartz, 1949; Bartels, 1951; Monaghan and Lytle, 1956; Lalou, 1954a, 1954b, 1954c, 1957a, 1957b; Oppenheimer, 1961; Ashirov and Sazonova, 1962; Greenfield, 1963; Shinano and Sakai, 1969; Berner, 1969, 1971; Ennever et al., 1971, 1974; McCunn, 1972; Shinano, 1972a, 1972b, 1972c, 1972d; Boquet et al., 1973; Adolphe and Billy, 1974; Krumbein, 1974; Billy, 1975; Deelman, 1975b; Morita et al., 1975; Aguilar et al., 1978; Morita, 1980; Novitsky, 1981; Moral et al., 1987), in recent carbonate accumulating environments, from soils to the marine realm (Vaughan, 1914; Field, 1932; Black, 1933b; Hatch et al., 1938; ZoBell, 1939; Purdy, 1963; Dalrymple, 1965; Monty, 1965, 1967, 1976; Christie and Floodgate, 1966; Deelman, 1975a; Friedman, 1975; MacIntyre and Videtich, 1979; Meredith, 1980; Sassen, 1980; Bubela, 1985; Andrews, 1988; Roberts et al., 1989), or in both (Nadson, 1903, 1928; Bavendamm, 1931, 1932; Hewitt, 1947; Gerundo and Schwartz, 1949; McCallum and Guhathakurta, 1970; Puri and Collier, 1967; Krumbein, 1968, 1978, 1979a, 1979b; Krumbein and Cohen, 1974, 1977; Krumbein et al., 1977; Danielli and Edington, 1983). This apparent wealth of literature should not allow one to be misled, as many of the workers cited above

merely allude to bacterially induced precipitation as one of several possible natural mechanisms for carbonate deposition because they seem unable to eliminate it.

There are several examples in which bacterially induced precipitates of calcium carbonate have been tentatively or conclusively recognized in the rock record (Brightman, 1938; Friedman, 1966, 1972a, 1972b; Berner, 1968; Cerda, 1973; Raiswell, 1976; Maurin and Noel, 1977; Klappa, 1979; Folk and Chafetz, 1980; Meredith, 1980; Maurin et al., 1981; Monty, 1982; Chafetz and Meredith, 1983; Folk and Chafetz, 1983; Kazmierczak and Krumbein, 1983; Chafetz and Folk, 1984; Folk et al., 1985; Tsien, 1985; Chafetz, 1986; Folk, 1986; Steinen et al., 1987; Jones and Ng, 1988; Tiezzi and Folk, 1984). Some of these workers have found bacterial remains associated with the deposits, others have inferred bacterial involvement based on other criteria, such as textural characteristics, or the isotopic composition of the carbonate deposit. A brief summary of some previous laboratory work with marine and nonmarine bacteria, including specific information about pertinent details where available, is presented below.

Wollny (1897, as noted in Hall and Miller, 1905) seems to have been the first to record the ability of bacteria to induce the precipitation of calcium carbonate. He worked with soil bacteria and his work was expanded by Hall and Miller (1905) who were concerned with the removal of calcium carbonate from the soil from an agricultural standpoint. Hall and Miller (1905) produced calcium carbonate with mixed cultures of soil bacteria.

Nadson (1903, from Nadson, 1928) first presented substantial evidence of bacterially induced precipitation of calcium carbonate by marine bacteria. He isolated several pure strains of bacteria from Lake Veisovoe, Russia, which could induce the precipitation of calcium carbonate. On two occasions, once with a mixed culture, and once with a pure strain, a high magnesian calcium carbonate, possibly dolomite, was formed after a 3.5, and a 1.5 year incubation period, respectively. In Ehrlich's summary of Nadson's experiments, he notes that: "In still other experiments, Nadson showed that bacterial decomposition of dead algae and invertebrates in seawater led to CaCO_3 precipitation." (Ehrlich, 1981, p. 108). One pure culture also produced ooids.

Drew (1911, 1912, 1913, 1914) investigated the ability of bacteria from assorted localities within temperate and tropical seas to decompose nitrates. Fortuitously, these denitrifying bacteria also induced the precipitation of calcite and although he was not a geologist, Drew (1911, p. 154) recognized the implications of this:

It has also been shown that these bacteria possess the power of precipitating Calcium carbonate from solutions of simple organic Calcium salts, and it is here suggested that some similar action has played an important part in geologic times in the precipitation of various rocks, wholly or in part composed of Calcium carbonate.

Drew (1911) also suggested that ooids, and the more recent deposits of mud from Marquesa Keys and several areas off of the Florida coast may have been formed by bacterial action. Drew, apparently unaware of the earlier

work by Wollny (1897, as cited in Hall and Miller, 1905), Nadson (1903, as cited in Nadson, 1928), and Hall and Miller (1905), believed that a specific type of denitrifying bacteria was primarily responsible for inducing the precipitation of calcium carbonate and, in a subsequent paper he proposed the name *Bacterium calcis* for this type of denitrifying bacterium (Drew, 1912). Drew (1911, 1912, 1913) used a variety of broth media containing nitrate and calcium salts, and reported the precipitation of calcite rhombohedra as well as ooid-like calcite concretions around nuclei of hydrated calcium sulfate particles which he added to the medium. Drew is generally given credit for recognizing the potential of bacteria to induce the precipitation of micritic calcium carbonate and as a result "drewite" was named after him (Gary et al., 1974). Lipman (1924, p. 182) notes that by 1913, the year of Drew's death, his hypothesis of bacterially induced precipitation of micritic carbonates had "...been pretty generally accepted by geologists interested in that phase of geology."

Based on their work with bacteria from water, oolitic sand, and bottom mud from the Great Salt Lake and areas near the Bahamas and Florida Keys, Kellerman and Smith (1914) outlined three processes for the bacterially induced precipitation of calcium carbonate. They renamed Drew's calcifying bacterium *Pseudomonas calcis* based on morphologic characteristics. They do not, however, describe the form of the precipitate, the media used, controls on the experiment, nor do they identify the mineralogy of the precipitate.

Although he had produced bacterially induced precipitates in the laboratory with a number of pure strains of bacteria, Lipman (1920, 1924, 1929, 1931) argued strongly against the possibility that bacteria produced substantial deposits of marine carbonates. He felt the conditions under which bacteria produced precipitates in the laboratory were rare or nonexistent in natural environments, but that all the bacteria that he isolated could, with the addition of certain salts, precipitate calcium carbonate. In his response to an article by Bavendamm (1931), Lipman (1931) conceded that bacteria may play some role in carbonate deposition in environments where bacteria were extremely abundant, such as mangrove swamps.

Bavendamm (1932) cultured a wide variety of pure strains of marine bacteria that could induce the precipitation of calcium carbonate. He believed that they were of importance in mangrove swamps and similar areas. Brief reviews on early work in this field may be found in ZoBell (1946, p. 100-103), Pautard (1970, p. 119-120), and Ehrlich (1981, p. 108-110)

From the time that Drew began publishing his articles in 1911, the question of whether bacteria did or did not play a significant role in calcium carbonate deposition in the natural environment has been debated. The debate, while it lasted, seemed quite vigorous (see Gee, 1932, for a brief summary of proponents, opponents, and the prevailing views), but the whole idea seems to have fallen from prominence around the early to mid 1930's until the late 1960's. To date, the only area in which the bacterially induced precipitation of calcium carbonate seems to be generally accepted

as a significant phenomenon is in association with calcite and native sulfur in cap rock. Articles frequently tend to refer to the bacterially induced production of calcite and sulfur in cap rock as an accepted fact, though there are still debates as to whether bacteria played an important role at a particular site (Feely and Kulp, 1957; Cheney and Jensen, 1965; Davis and Kirkland, 1970, 1979; Ruckmick et al., 1979; Sassen, 1980)

Subsequent work within the marine realm has most often, but not always, involved pure cultures. Descriptions of the crystals precipitated begin to show similarities both within and between individual studies by different workers. Lalou (1954a, 1954b, 1954c, 1957a, 1957b) reported the precipitation of spherulites and rhombohedra from unsterilized mud which he placed in an aquarium with marine water containing 0.5% glucose. He varied light, temperature, organic concentrations, and evaporation.

In many cases researchers began using smaller quantities of nutrients in an effort to more nearly approximate natural environments, and to answer a major complaint of opponents of the concept of naturally occurring bacterially induced precipitation. Oppenheimer, (1961) rinsed Bahama Bank oolites and inoculated aged, filtered seawater containing 0.1% sodium nitrate with the rinse water. Three flasks were incubated at room temperature in the dark and precipitation occurred in all three flasks, including a control flask, within a month. Crystals in the control flask were described as "aragonite crystals parallelly arranged in sheaves or bundles" (Oppenheimer, 1961, p. 295). The crystals in the flasks inoculated with bacteria "...were in a radiate globular form in which the

centers were or were not of concentric design and spherical." (Oppenheimer, 1961, p. 295). Oppenheimer (1961) noted that differences in the precipitates may have been within experimental error, or they may have been due to either crystal nucleation sites on the glass, or organic ooze from living cells.

Krumbein appears to have been the most prodigious researcher in the field of bacterially induced precipitates in the 1970's. Krumbein and others produced dumbbells (Krumbein, 1979b) and assorted types of spherules (Krumbein, 1974, 1979b; Krumbein and Cohen, 1974, 1977; Krumbein et al., 1977) with a variety of marine bacteria under numerous conditions. Krumbein and his coworkers have attempted, in many instances, to more closely approximate natural conditions in their experiments.

Malone and Towe (1970) produced struvite, monohydrocalcite, and high magnesian calcite with mixed cultures, simple growth media, and non-sterile conditions. The monohydrocalcite formed as spherules.

McCallum and Guhathakurta (1970) used 46 pure cultures of bacteria obtained from calcareous sediments collected at Bimini, Brown's Cay and Andros Island, Bahamas in conjunction with six different media. All cultures were able to precipitate rosettes and bundles of aragonite needles in one or more media. Precipitation occurred during a fall in pH. Bacteria could be seen at the centers of some rosettes, and they may have acted as nuclei for precipitation. No aragonite precipitation occurred in the absence of bacteria.

Boquet et al. (1973) isolated 210 strains of soil bacteria and cultured them on solid media. All strains that could grow on their B-4 media (including several non-soil bacteria from their laboratory collection) induced the precipitation of calcite dumbbells. Although workers in other disciplines had demonstrated that bacteria could induce calcium carbonate precipitation, Boquet et al. (1973, p. 258) seem to have been the first to be credited with the conclusion that "...crystal formation is a function of the medium used and that under suitable conditions most bacteria can form calcite crystals."

Deelman (1975b) induced the precipitation of "spherulitic aggregates" of aragonite with cultures of sulfate reducing bacteria. He further noted a relationship between crystal morphology and microbial activity. No precipitation occurred in the absence of bacteria.

Morita (1980) examined the ability of 73 pure cultures of facultative aerobic bacteria obtained from water above Lodestone and Keeper Reefs of the Great Barrier Reef, Australia, to induce the precipitation of calcium carbonate in aerobic and anaerobic broth media. Of the 73 cultures, 50 produced calcite hemispheres under anaerobic conditions, and five produced calcite hemispheres under aerobic conditions. The hemispheres liberated copious quantities of bacteria upon dissolution with acid. No precipitation occurred in the absence of bacteria.

Novitsky (1981) obtained mixed calcite/aragonite "buttons" from ten of 53 random isolates from Bermuda waters and sediments in growth media under aerobic and anaerobic conditions. He attributes the precipitation of

calcium carbonate to the ability of the bacteria to raise the pH of the medium. He demonstrated this by artificially increasing the pH of sterile media, and by filter sterilizing media whose pH had been increased by growing bacteria. In both cases precipitation occurred and the precipitates from the filter sterilized flask were indistinguishable from those occurring in inoculated, unsterilized flasks. He did not comment on the form of the precipitate obtained by the addition of bases to his media.

The previous listings contain much of the laboratory work that has dealt with bacterially induced precipitation of calcium carbonate. Similarities between the precipitates are clear. Some are described as rhombohedra, most are described as some form of bundles of crystals, including: sheaves, dumbbells, spheres, buttons, hemispheres, peloids, pellets, ooids, spherules, spherulites, and spherulitic aggregates. The similarity is striking considering the span of time over which the experiments have been conducted, the variety of pure and mixed cultures of bacteria that have been used under sterile and non-sterile conditions, and the different media and conditions that have been employed. This lends credence to the postulation that the bacterial precipitation of calcium carbonate is a passive process, and that when these forms are present in ancient rocks, bacteria may have been instrumental in their precipitation.

It should be noted here that work has been conducted on bacteria which induce the precipitation of other minerals such as iron sulfides (Rickard, 1969), calcium hydroxylapatite (Ennever, 1963), calcium phosphate (Ennever and Creamer, 1967), sulfur (Jones et al., 1956; Feely

and Kulp, 1957), siliceous sinter (Vanyo et al., 1986), manganese and iron (Krumbein, 1969), apatite (Berge, 1972; Ennever et al., 1974), struvite (Malone and Towe, 1970; Rivadeneyra et al., 1983), magnetite (Blakemore et al., 1985; Lowenstam and Weiner, 1989), assorted sulfides and phosphates (Beveridge et al., 1983), pyrite, marcasite, pyrrhotite, greigite, mackinawite (Rickard, 1969), to list a few, in various environments (see Trudinger and Mendelsohn, 1976, for a more complete discussion). However, this study deals primarily with laboratory precipitates of calcium carbonate from cultures of aerobic and facultative bacteria that were collected from near shore environments associated with filamentous cyanobacterial mats, and their comparison to naturally occurring samples from identical or similar sites.

FIELD AREAS

Live bacteria and recent sediment samples were collected from two modern carbonate accumulating areas: (1) Kleberg Point, a marine algal tidal flat in Baffin Bay, Texas, (Dalrymple, 1965; Behrens and Frishman, 1971; Land et al., 1979), and (2) water-filled depressions in a karstic terrain (adjacent to Fresh Creek) and a fresh-water pond (near Ginette Pond) on Andros Island, Bahamas (Black, 1933a; Monty, 1965) (Figures 1, & 2A, B). The algal mat at Kleberg Point had formed on top of primarily carbonate sediment with some quartz sand. Black, organic-rich laminations were apparent within a dark colored sediment to approximately 20cm below the surface, however, from 10cm downward they were interspersed with increasingly thick lighter colored laminations. No lithified horizons were encountered during either of two trips and calcified filaments were only detected in one sample.

Material from Andros Island was collected from water-filled solution cavities in the karstic limestone described by Monty (1965). At the time of collection there were from 2-40cm of water over the algal mat and the combined mat/sediment thickness ranged from about 2-40cm as well. There were no lithified horizons within the sediment layers, however, carbonate coatings on algal filaments were apparent with a hand lens and there were freshly encrusted mangrove roots at the Ginette Pond site.

Samples of recent sediments from inland lakes were collected from San Salvador, Bahamas (Figure 2A, C). Some of the lakes were fed

Figure 1. Kleberg Point sample site at Baffin Bay
(map after Behrens and Frishman, 1971).

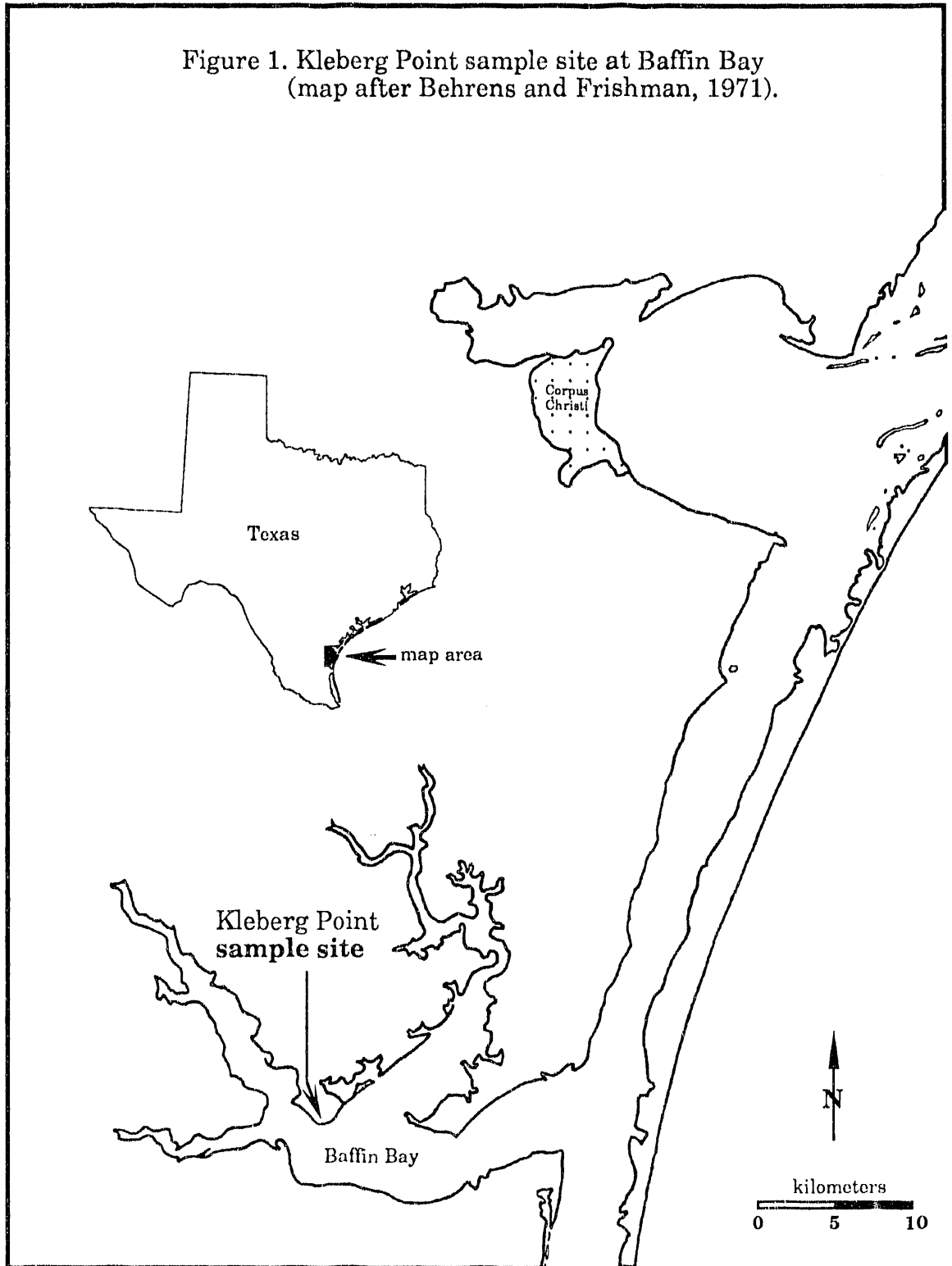

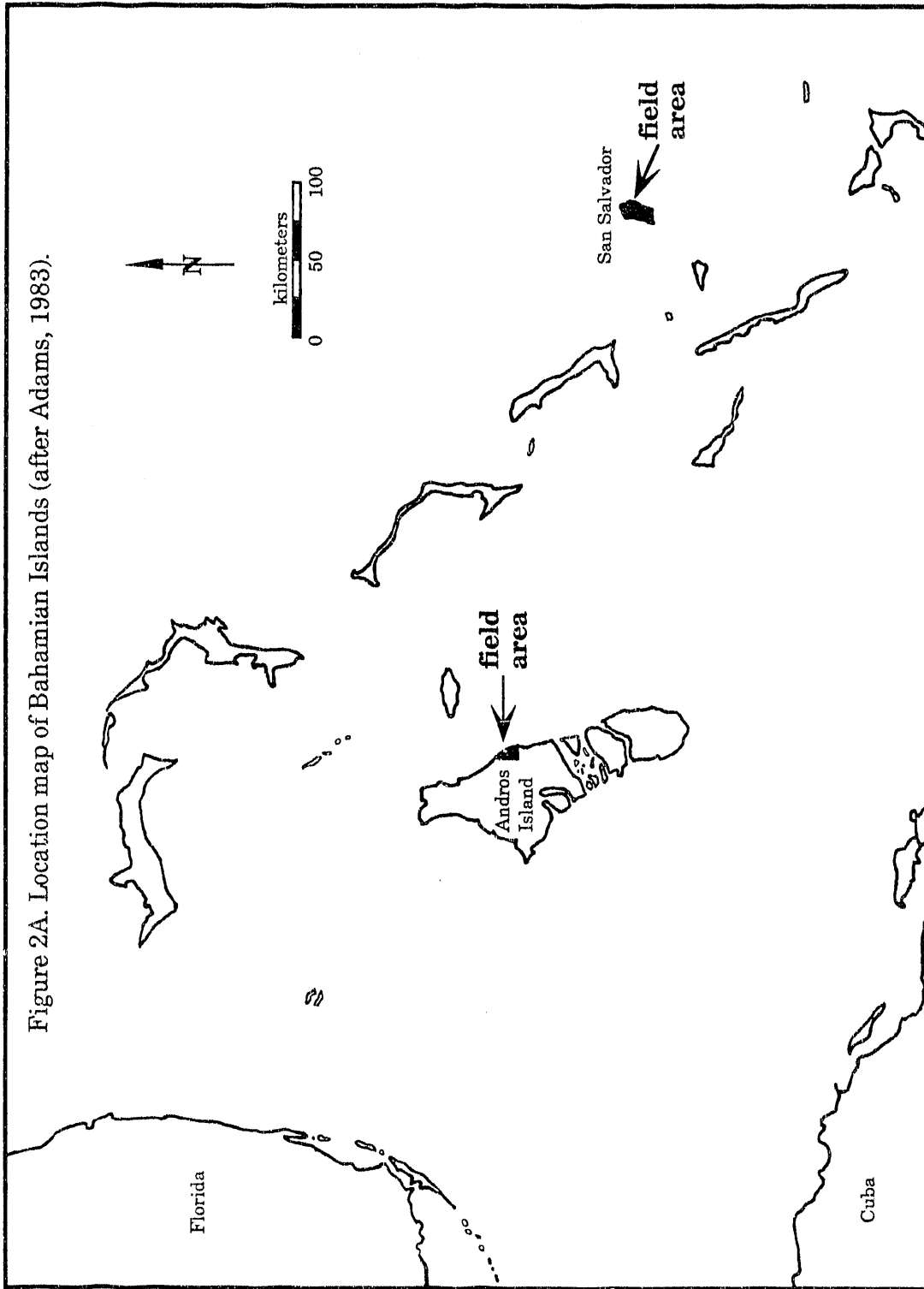

Figure 2A. Location map of Bahamian Islands (after Adams, 1983).

Figure 2B. Ginette Pond and Fresh Creek sample sites on Andros Island (after Monty, 1965).

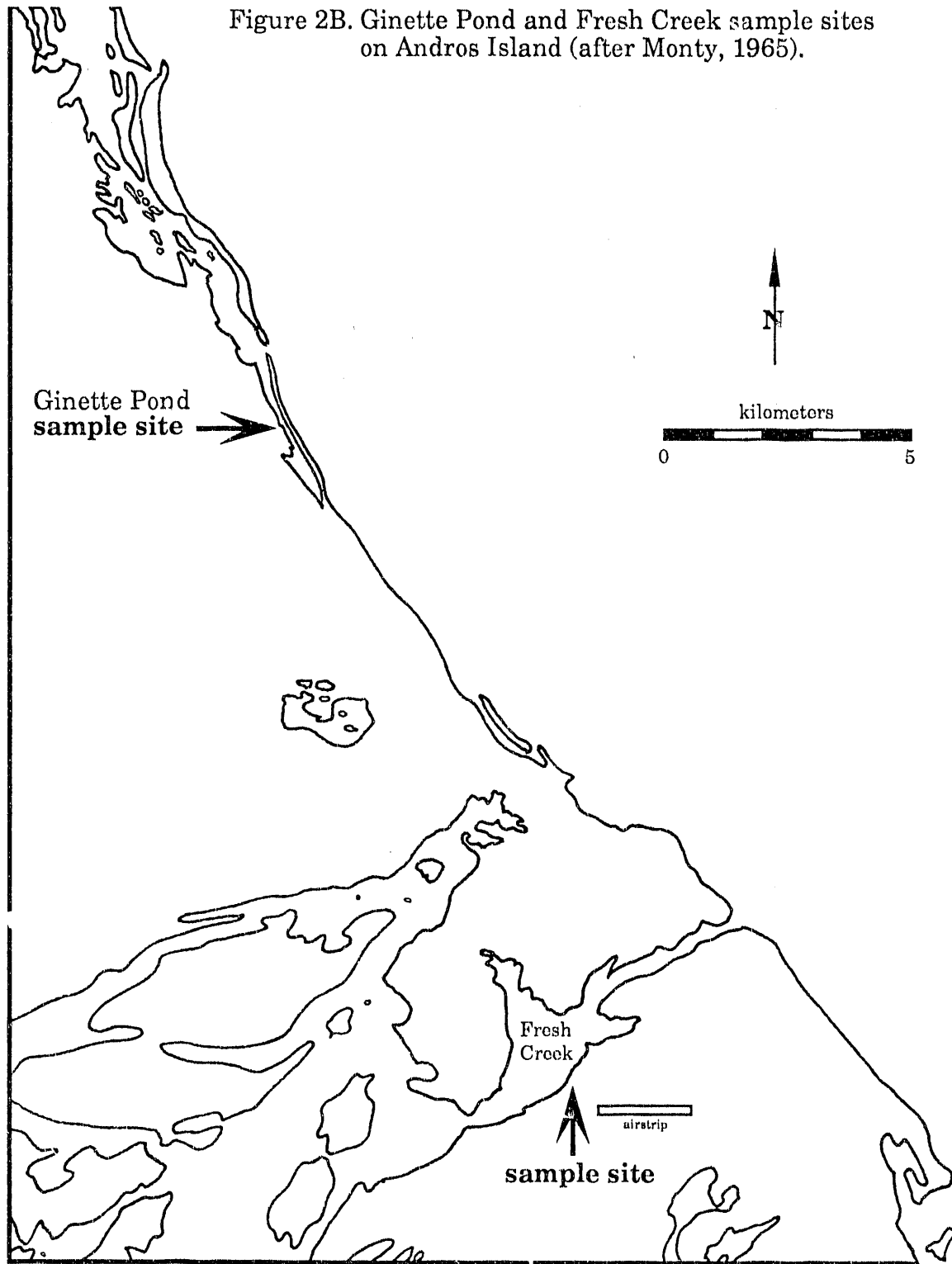
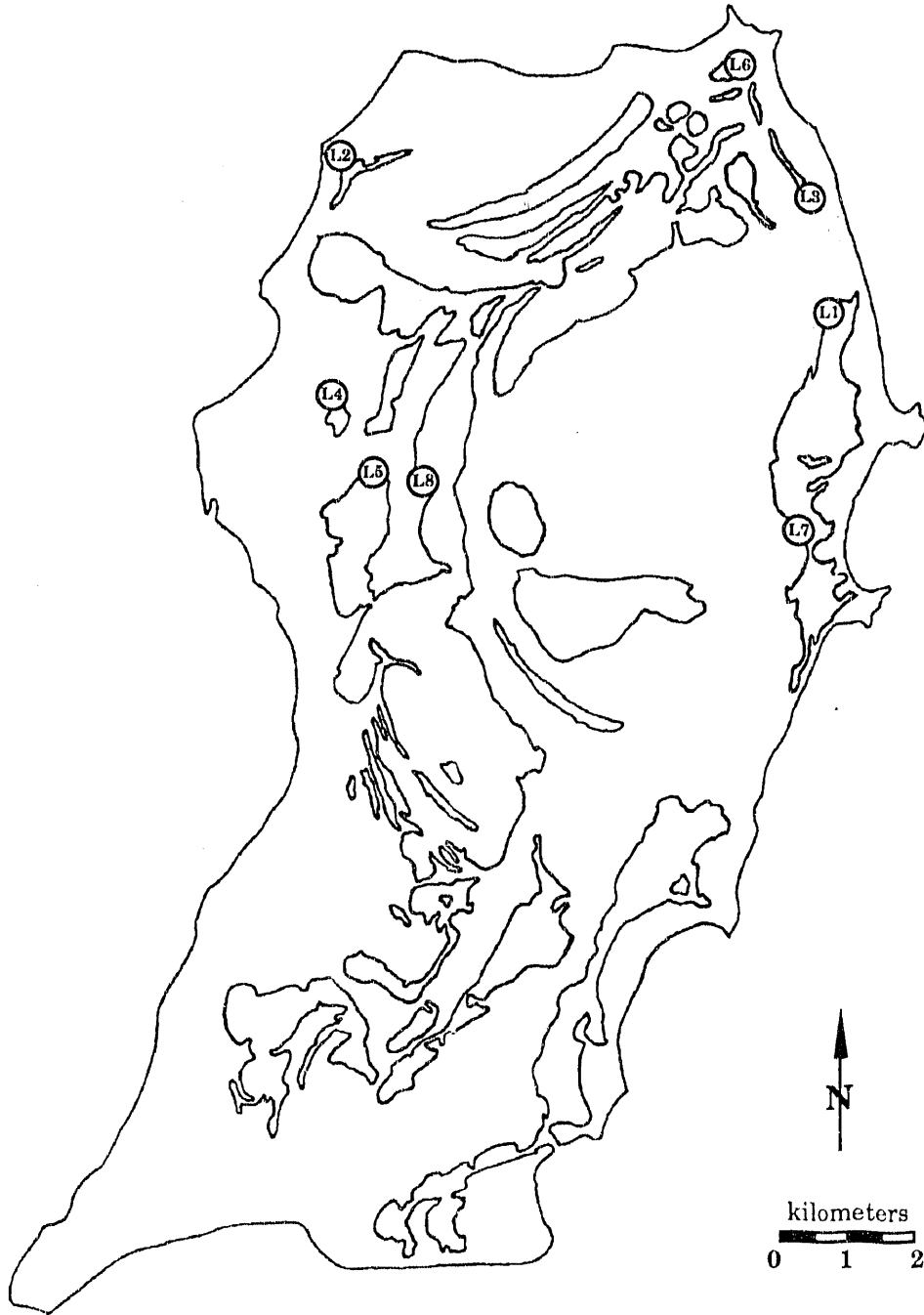

Figure 2C. Map of collection sites L1-L8 on San Salvador (map after Mylroie, 1983).



primarily by rainwater and were nonsaline or only slightly saline, others were connected by underground conduits to the marine environment and were influenced by tidal exchange with marine water. In the absence of frequent rainfall some lakes became hypersaline. Most of the eight lakes sampled were less than 2m deep and sampling was done in areas less than 1m deep. The lakebeds are karstic limestone and are generally covered by less than 40cm of sediment and organic matter. In most lakes, precipitation of, and cementation by, calcium carbonate was actively occurring as was indicated by white particles disseminated in algal and/or bacterial mucilage, and freshly encrusted organic matter, including roots, branches, and leaves (note: "mucilage" and "gel" are used interchangeably here, and the distinctions noted by Golubic, 1976b, are not used).

METHODS

FIELD

Live bacteria from Kleberg Point, Baffin Bay, were collected in 1988 as part of relatively undisturbed algal mats and as adherents on collecting tools. Some pieces of algal mat and the underlying sediment were deposited directly into a nutrient-rich broth. Other samples were collected by pushing a sterilized pipe cleaner into algal mats, mud deposits, oolitic areas, and the underlying bacteria-laden sediment to a depth of 2-3cm. The pipe cleaners were then embedded in a non-nutritive gelled agar contained in 1 dram glass vials, and the vials sealed with screw-on caps. Four duplicate samples were collected at each site and mineral oil was placed into the tops of two of these samples to prevent oxygen from reaching the bacteria. All media, tools, and materials, were sterilized prior to use. The agar was made with water approximating the salinity of the water from which the samples were collected. The vials were put on ice within a few hours of collection and remained that way until they could be returned to the laboratory where they were refrigerated and subsequently cultured.

Several 1.5cm diameter cores of sediment were taken at each collection site at Baffin Bay. These cores were placed in a solution of 6% glutaraldehyde and 94% artificial seawater. The cores penetrated to a depth of about 6cm. These samples were also put on ice until they could be returned to the laboratory for examination. On an earlier trip in 1985,

several 15cm diameter cores were collected to a maximum depth of about 80cm. These cores were untreated.

During two trips to Kleberg Point, water depth over the mat ranged from 0.0-0.5m, salinity (determined in the field with an American Optical specific gravity tester) ranged from 62-75‰, pH (measured in the field with an Orion 407A specific ion meter equipped with an Orion 91-04 spear point pH electrode) averaged 8.7, and temperature averaged 24°C. The pH of the algal mat and sediment was approximately that of the water at the mat's surface. Values reached a minimum of pH 7 or slightly less at about 1-2cm below the mat surface and began to rise thereafter for the next half centimeter. The pH probe was too short for measurements of deeper sediment.

The samples of live bacteria from Andros Island were collected only on the sterile pipe cleaners. A minimum of two duplicate samples were collected from each site. Again, samples were put on ice within a matter of hours after collection and kept cool until they were returned to the laboratory.

Cored samples were also collected from Andros Island and placed into a solution of 10% isopropyl alcohol, and 90% water obtained from the collection site. Some cores were approximately 1.5cm in diameter, and 6cm long. The majority of the cores were 4.5cm in diameter, and 2-3cm long.

In addition to the samples of live bacteria and core samples, control samples were collected from both Baffin Bay and Andros Island. These consisted of sterilized pipe cleaners that were transferred to the vials

without pressing them into the algal mat and the underlying bacteria. These were used to insure that the collection techniques did not introduce foreign bacteria into the samples, that is, non-sediment bacteria did not somehow contaminate the samples.

Sediments, encrusted rocks, algae, bacteria, and gelatinous slime were collected from San Salvador, Bahamas, in early 1986. No attempt was made to collect live bacteria from this site. Representative portions of all samples were placed in a 90% isopropyl alcohol, 10% formalin solution within a few hours after sample collection to preserve the organic material, however, this does not preserve bacteria well as they undergo lysis.

LABORATORY

Media and Culturing Techniques

The basic medium used for the experiments in this study was 2216 (ZoBell, 1941). This medium was modified to form 2216E (Gunkel and Reinheimer, 1968, as noted in Krumbein, 1971), and 2216E was further modified for anaerobic bacteria (Krumbein, 1971). The composition of 2216 prepared as a broth, for normal marine salinity is: 5.0 g/l bacto peptone, 0.1 g/l ferric phosphate, and 1.0 liter seawater (ZoBell, 1941). Medium 2216E requires the addition of 1.0 g/l yeast extract, and 2216E for anaerobes requires further additions of 5.0 g/l glucose and 0.1 g/l ascorbic acid. Other modifications to these basic media included the addition of one or more of the following: 7-15 g/l purified agar, 1.7 g/l KNO_3 (potassium nitrate), 2.22

g/l TMAO (trimethylamine-N-oxide), 1.0 g/l CaCl_2 (calcium chloride), live cyanobacteria (unsterilized), and dead cyanobacteria (sterilized). The CaCl_2 was used as the calcium source for fresh-water media. Aged (ZoBell, 1946), filtered, and sterilized Baffin Bay water was used as the sole medium in a few experiments.

A premixed commercially available product was used when 2216E of normal marine salinity was prepared. For media of twice normal marine salinity and nonsaline media, aged Baffin Bay water and distilled water, respectively, were used and the media were prepared from scratch. In all cases the chemicals were dissolved, the solution was brought to a boil for two minutes, filtered through coarse filter paper, and steam autoclaved for a minimum of 20 minutes at 124°C to sterilize the solution. Where a firm medium was desired, 7-15 g/l of purified agar were added after the medium was filtered, the solution was reheated to dissolve the agar, and then sterilized as described above. Concentrated solutions of KNO_3 and TMAO were filter sterilized with a $0.45\mu\text{m}$ cellulose acetate membrane filter and added to the 2216E after it was steam sterilized to obtain the desired final concentration. The pH of the final medium was not adjusted, but was within the range of 7.4-7.6 in a few representative samples that were measured. When dead cyanobacteria were used they were steam sterilized in an autoclave as described above. No attempt was made to sterilize the live cyanobacteria and, consequently, bacteria that live in association with the cyanobacteria were introduced into any experiments in which live cyanobacteria were used.

Some attempts were made to establish bacterial cultures in sediments immersed in various media listed above. Baffin Bay ooids, and fine-grained quartz sand and assorted shell hash from Galveston beaches were used whole for this purpose, as were their pulverized equivalents. Pulverized dolomite from the AA2 Limestone of the Lueders Formation was also used. The quartz sand was dry sterilized in an oven at a minimum of 170°C for 4 hours. Small quantities of the other sediments were immersed in media and steam sterilized in an autoclave as described above.

Glass receptacles (primarily 4 and 8 ounce square borosilicate glass bottles and 13 and 16 millimeter diameter borosilicate test tubes) for the media were washed with concentrated hydrochloric acid, rinsed repeatedly with deionized water, and steam sterilized in an autoclave, with the desired media in them if possible. Some test tubes were modified so that broth media could be percolated through a sediment column (Figure 3). Presterilized plastic petri dishes were used for most of the gelatinous media.

When the samples of bacteria were returned to the laboratory, mixed cultures of aerobic and facultative bacteria were grown at ambient room temperature (average of 22°C) in both the liquid and gelatinous forms of several types of media described above. Mixed cultures were used because they more closely approximate a natural environment and are generally of more value from a geologic standpoint (Lalou, 1957b; Wood, 1967, p. 226; Novitsky, 1981). Both liquid and gelatinous media were used because the liquid media approximates an open marine (or fresh-water) environment

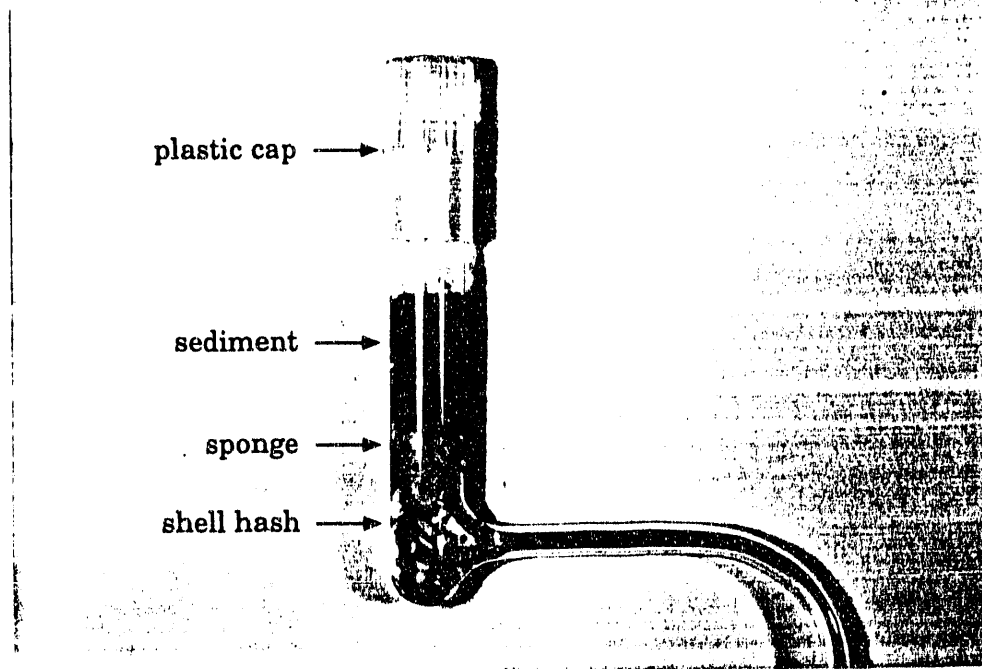

Figure 3. A 16mm diameter test tube with a drain glassblown onto it. The tubes contained a shell hash for drainage, a sponge to prevent rapid flow of liquid through the system, and sediment composed of washed Baffin Bay ooids. The plastic cap was periodically removed and fresh sterile nutrient broth was added to maintain the liquid level at about 3cm above the top of the sediment. The drain tube was placed through a double hole rubber stopper and the stopper was inserted into the top of a flask. The other hole in the stopper was connected to a syringe. When liquid was to be drawn through the sediment the plunger was gently pulled part of the way out of the syringe to create a lower pressure within the flask which then drew the liquid into it. Rates of liquid flow could be regulated rather precisely to prevent rapid filtration of liquid through the sediment.

and the gel approximates the mucilaginous slime secreted by some bacteria and algae. In nature, precipitation of calcium carbonate often begins in the mucilage surrounding algal filaments (Monty, 1965, 1972). Simkiss and Wilbur (1989, p. 23) have made the following observation:

...a large number of bacterial activities are likely to induce mineral formation if they occur in suitable solutions. It must be emphasized, however, that most of these products occur extracellularly and there will only be a deposition of mineral if the solubility product is exceeded at that local site. Many of the most spectacular consequences of bacterial biomineralization are only apparent, therefore, in the rather complex ecological aggregates of organisms that permit these local environments. This is perhaps best seen in stromatolites...

It would seem that algal mucilage would be an ideal site for "bacterial biomineralization". Because diffusion through the mucilage is slow, microenvironments could be established and maintained more easily by bacteria and/or algae. Caldwell and Caldwell (1978) have found that bacteria are six orders of magnitude more abundant within algal mucilage than the surrounding water in the areas they studied, and Pentecost (1978) has observed that within the blue-green algae he studied, those with mucilaginous sheaths generally displayed more precipitate than those without a mucilaginous sheath. So mucilage may also act as a favored site in nature for bacterially induced precipitates. The material from Baffin Bay was cultured in media of normal and twice normal marine salinity. The salinity of the water over the algal mat at Kleberg Point was approximately twice normal marine salinity (62-75‰) where the bacteria

were collected. The same media were used to culture the bacteria from Andros Island, except nonsaline and normal marine salinities were used. These bacteria were collected from a nonsaline environment. In addition, for every experimental run, sterile (non-inoculated) controls were established to insure that: (1) the media and glassware had not been contaminated, and (2) precipitation did not occur in the absence of bacteria. The non-inoculated and inoculated experiments were identical in all other ways. Variations to this general procedure included one or more of the following: aeration of broth media; absence of light; incubation at 35°C; and anaerobic conditions.

Broth cultures were made from the field samples and one or more sterile experiments were inoculated at a time from the initial culture by adding a few drops to a broth, or by smearing a sample of liquid onto agar with an inoculating loop. Containers for aerobic cultures were plugged with sterile nonabsorbent cotton wadding, or capped with plastic closures that allowed the circulation of air but prevented contamination by airborne bacteria. Some cultures were grown anaerobically in broth by inoculating the broth, filling the glass container to overflowing, and sealing it with a screw-on cap. Any remaining oxygen was quickly metabolized, and the cultures turned black and became anaerobic throughout within a few days at most. Cultures were also grown anaerobically with gelatinous media by mixing warm, unsolidified, gel with the bacteria so that they would be encased in it and shielded from the atmosphere when it became firm. Alternatively, agar in petri dishes was smeared with bacteria from an

inoculating loop and the petri dishes were placed in a desiccator. Hydrogen and carbon dioxide were generated in the desiccator with commercially available packets containing tablets of sodium borohydride, and sodium bicarbonate and citric acid. Oxygen was removed from the system by a reaction with the hydrogen, in conjunction with a palladium catalyst, to form water.

Treatment of Field Samples and Laboratory Precipitates

Laboratory precipitates from broth cultures were collected and processed in a variety of ways. When possible, samples were collected at intervals and the experiments were allowed to continue relatively undisturbed. Samples of crusts floating on the surface of broth cultures were removed with a flame sterilized inoculating loop. Precipitates that had settled on the bottom of the container, or that were suspended in the liquid column were collected with a sterilized pipette. When experiments were concluded, the containers were drained and rinsed with distilled water and all the liquid was collected and centrifuged. Some of the solid matter was untreated or rinsed with distilled water, other portions were treated with either 30% H_2O_2 (hydrogen peroxide), 5.25% NaOCl (sodium hypochlorite) or both (but not simultaneously), after which they were repeatedly rinsed and centrifuged to collect the remaining solids.

Petri dishes were inverted and placed directly under the microscope so that precipitates could be examined without ever exposing the culture to

contamination. However, owing to the thickness of the agar, only low and medium magnifications could be obtained in this way. Small segments of the agar which contained precipitates were removed from gelatinous media with an assortment of flame sterilized tools and the experiments were allowed to continue. These segments of gel were then placed directly on a clean glass slide for microscopic examination, or heated in 30% H_2O_2 to dissolve the gel from around the crystals. The most efficacious method for the removal of precipitates from gelatinous media at the termination of the experiment was to either scrape the top layer of gel, which contained the majority of the precipitate, from the petri dish, deposit it in a minimum quantity of near boiling 30% H_2O_2 to rapidly dissolve the agar, and pour the resultant liquid into a small quantity of ice water in an ice bath. An alternate method involves pouring boiling water (the adventurous may try 30% H_2O_2) on the surface of the agar in the petri dish so that it flows over it and into a minimum amount of ice water in an ice bath. In either case the solid particulate matter was removed from the resulting liquid by centrifuging.

Samples of both naturally occurring material, and laboratory precipitates were examined using a Cambridge Stereoscan 250 Mk3 SEM (scanning electron microscope). Prior to examination, some samples of naturally occurring material were cut into 1-2mm thick slices, fixed, and critically point dried with a Polaron E3000 Critical Point Drying Apparatus to preserve the structure of the organic matter. Samples were prepared in two separate ways for critical point drying depending on their treatment in

the field. Samples that were neither fixed nor preserved in the field were fixed, as follows, after returning to the laboratory (Danielli and Edington, 1983):

2 hours in:	2.5% glutaraldehyde diluted with 0.1M phosphate buffer (pH 7.4) at room temperature.
5 minutes each in:	Two changes of pure buffer at room temperature.
30 minutes each in:	Two changes of pure buffer at room temperature.
Overnight in:	Pure buffer at 4°C.
30 minutes in:	1% OsO ₄ (osmium tetroxide) in buffer.

and dehydrated as follows (Danielli and Edington 1983):

30 minutes each in:	Acetone, 70% and 90%.
30 minutes each in:	Two changes of dry absolute acetone [B.D.H. molecular sieve type 4A described by Danielli and Edington, 1983, was not used].

Samples that were fixed in the field with glutaraldehyde or preserved in an alcohol solution were not fixed in the laboratory, but were dehydrated as follows (Polaron E3000 instruction manual, 1985):

15 minutes each in:	30%, 50%, 70%, 80%, 90%, 95%, 100%, and 100% ethanol.
---------------------	---

15 minutes each in: Amyl acetate/ethanol mixtures of the following proportions: 25%/75%, 50%/50%, 75%/25%, 100%/0%.

Following dehydration, samples were critically point dried with dry carbon dioxide as directed in the Polaron E3000 instruction manual (1985).

Analytical Techniques

As noted above, a Cambridge Stereoscan 250 Mk3 scanning electron microscope was used to examine precipitates and organic matter from both laboratory experiments and from natural samples collected from field areas. An EDAX 9100 was used for the energy dispersive analysis of x-rays, of a few samples of laboratory precipitates, to obtain a semi-quantitative value for magnesium content.

The naturally occurring organic material and sediments were impregnated, thin sectioned, and examined with an Olympus BH-2 petrographic microscope. Thin sections were also examined with BH2-RFL fluorescence and Nuclide ELM-2B luminoscope attachments to observe the distribution of organic material and, possibly, trace elements, within the sediment grains and cements. Samples of laboratory precipitates were also examined with these microscopes, however, they were examined intact in gelatinous media, or as loose grains. Neither fluorescence nor cathodoluminescence revealed characteristics which were of value for distinguishing bacterially induced precipitates so they will not be discussed further.

X-ray diffraction analyses of powder mounts of some field samples and laboratory precipitates were made with a Siemens D5000 x-ray diffractometer to confirm their mineralogy.

Thirty-six samples from five different lakes on San Salvador, Bahamas, were analyzed for Fe, Zn, Ca, Mg, Sr, Mn, Na, and K with a Perkin-Elmer 5000 atomic absorption spectrophotometer. The samples were sorted into four size ranges: less than 62 μ m, between 62 μ m and 250 μ m, between 250 μ m and 590 μ m, and greater than 590 μ m. The samples in the greater than 590 μ m size range included lithified crusts. Some samples were bulk samples, others were picked to exclude shell material, ostracode carapaces, and other actively precipitated carbonates. Two of the samples were from the karstic host limestone, and two were from mollusc shells.

The following procedure was used to prepare samples for atomic absorption analysis. A 1:4 solution of approximately 12 molar hydrochloric acid and distilled water was prepared. A quantity of distilled water sufficient to complete an entire run was also prepared. Filter papers were soaked in some of the acid/water solution for a few minutes, rinsed in distilled water, air dried, and weighed to ± 0.0001 grams. Approximately 0.150 grams of sample were weighed to ± 0.0001 grams, dissolved in 20ml of the stock acid/water solution, allowed to sit in 50ml covered glass beakers for 12 or more hours, and passed through the conditioned filters to remove any insoluble residue. The liquid was collected in 100ml volumetric flasks, the beakers were rinsed with less than 80ml of distilled water, and the

liquid was poured through the filter paper bringing the total volume of the sample to just less than 100ml. Distilled water was added to bring the sample volume to exactly 100ml. These samples were analyzed for trace elements. Dilutions of each sample (generally 1:100) were prepared for the analysis of elements present in high concentrations. The final sample weight used to determine weight percent values in ppm (parts per million) was calculated based on the sample weight, and the weight of the dry filter paper before and after filtration.

A Finnegan-Matt Delta-E mass spectrometer was used to analyze the carbon and oxygen isotopic signatures of 31 field samples and five laboratory precipitates. 5-10 milligram samples were reacted with 100% phosphoric acid at 50°C for 15 minutes to liberate carbon dioxide gas for analysis. The sample gas was compared to UH-2, an in-house standard, which was repeatedly calibrated against NBS 19 and NBS 20, and analyzed by laboratories at the University of Texas at Austin, and the University of Michigan. In the approximately three years during which UH-2 has been used the values have been $0.65 \pm 0.13\text{‰}$ $\delta^{13}\text{C}$ PDB, and -4.36 ± 0.21 $\delta^{18}\text{O}$ PDB.

RESULTS

In virtually all of the more than 120 experimental runs under aerobic conditions, precipitation of calcium carbonate occurred in both the liquid and gelatinous media that had been inoculated with mixed aerobic and facultative cultures of bacteria. No pure cultures were used. The experiment was deemed positive based on the appearance of a precipitate which was clearly visible under a light microscope at a magnification of 400x or less. There are more rigorous tests that could have been employed to determine if any particles not visible at 400x magnification had formed (Novitsky, 1981), however, as virtually all inoculated experiments yielded a readily visible precipitate within a matter of hours or days, the added effort was not deemed worthwhile.

Precipitation occurred in virtually all liquid media within a matter of days. In a few representative samples that were measured, the pH was always above 7, and ranged from 8.04 to 8.8 at the termination of the experiment. Precipitation occurred more rapidly, sometimes in a matter of hours, when the liquid was aerated. Aeration also caused agitation which prevented crusts from forming at the air/liquid interface.

In gelatinous agar media precipitation was generally not apparent until a few days after inoculation. The precipitate was intimately associated with the bacteria. Crystal nucleation occurred in close association with the colonies of growing bacteria that had been streaked onto the agar (Figure 4). This was, presumably, the sphere of influence of

Figure 4. Thin section photomicrographs of gelatinous growth media with Baffin Bay bacteria (A-D) and Andros Island bacteria (E & F) and calcium carbonate crystals. A) Crystals (the spherical masses) only form within the area inhabited by bacteria (top view). The grey area (indicated by arrows) is the leading edge of the bacterial growth. B) In this cross-sectional view, observe that crystals only form near the surface of the gel, under a film of bacteria. C & D) A close-up view of A in plane light and crossed polars, respectively, showing some of the spheres and dumbbells which formed in the mass of growing bacteria. Crystals are radially arranged in the spheres and concentric bands are commonly visible in the larger aggregates. E & F) Masses of calcium carbonate crystals that formed crusts in a band of bacteria, in plane light and crossed polars, respectively (top view). A few isolated bacterial colonies can be seen above the band, and crystals had started forming in one in the upper right corner. In gelatinous media, crystal precipitation occurs in intimate association with bacteria.

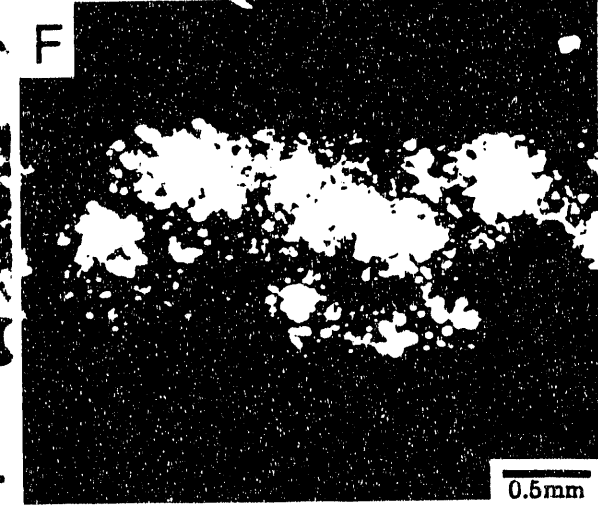
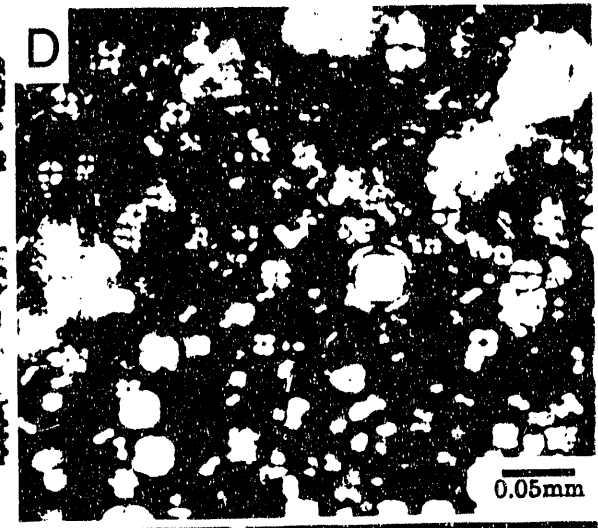
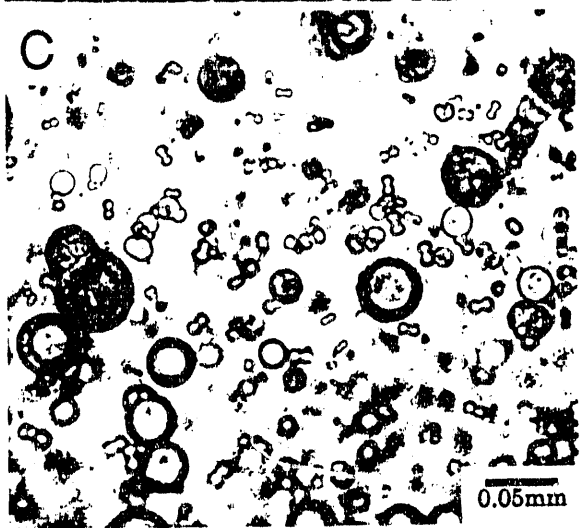
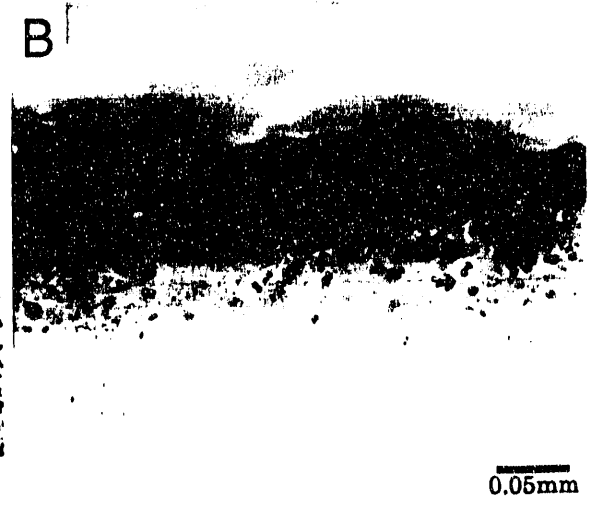

the bacteria on the environment and the absence of bacteria resulted in the absence of a precipitate.

In both solid and liquid media, higher incubation temperatures apparently increased the metabolic activity of the bacteria and precipitation proceeded more rapidly. This effect is common and it has been noted previously (Lalou, 1957b; McCallum and Guhathakurta, 1970; Morita, 1980; Novitsky, 1981; Ferrer et al., 1988). Some unique precipitates occurred when CaCl_2 was used as the calcium source in fresh-water gelatinous media. No differences were noted between cultures grown in the absence of light, and those grown in whatever light the laboratory received from natural and artificial sources.

Precipitation of some material, possibly calcium carbonate, did occur in anaerobic broth cultures, however, experiments were allowed to continue and the precipitates dissolved before they could be collected (in the few measured, pH values were acidic when the experiments were terminated). Other workers have formed precipitates under anaerobic conditions (Morita, 1980; Novitsky, 1981), and Danielli and Edington (1983) actually found that precipitation in gelatinous media occurred preferentially in areas of acidic pH values. No precipitation was apparent in gelatinous media with anaerobic cultures, nor was precipitation apparent in the sediment column in experiments where sediment was used.

Precipitation did occur in media that consisted only of aged, filtered and sterilized Baffin Bay water. The precipitates closely resembled those

formed with nutrient enriched media, however, they were volumetrically very small comparatively. In addition, they appeared more translucent because there were fewer inclusions of bacteria, perhaps because the sea water could not support large bacterial populations, or the crystals formed more slowly and did not enclose bacteria as frequently.

Precipitation occurred in four of the control (non-inoculated) experiments. In three cases the gelatinous medium was twice normal marine salinity and it had begun to dry. An evenly distributed precipitate began to form over the entire surface of the agar, forming first at the edges (the driest area) and progressing inward as drying continued. In none of these cases were the controls contaminated by bacteria, although the same phenomenon was observed in plates that had been inoculated with bacteria. This form of abiogenic precipitation has been readily reproduced since it was noted in the experiments. In the fourth case, a sterile control for a broth medium had been exposed to the atmosphere to make a pH measurement at the termination of an experiment. It was contaminated by mould and bacteria which induced the precipitation of a floating crust of calcium carbonate at the base of the mould some days later. In these isolated cases in which precipitation did occur in control experiments, there was a simple, reasonable explanation and the precipitate is, in all cases, readily distinguishable from purely bacterially induced precipitates.

Bacterial growth did not result when control samples from the field were placed in growth media, nor did bacterial growth result on or in controls which had not been inoculated (except in the cases noted

immediately above). Therefore, it is certain that the precipitates of calcium carbonate formed in response to some aspect of the bacterial activity and the bacterial cultures were not contaminated by foreign bacteria.

PRECIPITATE FORM AND HIERARCHY

The structure or form of the laboratory precipitates can generally be divided into four size-related hierarchical levels, from features visible with the naked eye, to some which are visible only at or near the upper limit of SEM resolution for samples of this type. From the largest to the smallest they are: (1) crusts formed of cemented crystal bundles, (2) characteristic bundles or aggregates of individual crystals, (3) individual crystals, and (4) 0.1-0.4 μ m diameter spheres or rods of calcium carbonate of which individual crystals were sometimes composed (Figure 5).

Crusts

Crystal bundles grow together to form macroscopic crusts which occur most frequently at the air/liquid interface in broth media (Figures 5A, & 6A-D). The interface appears to be a favored site for precipitation (also noted by Berkeley, 1919), probably because of both evaporation and oxygen availability for the aerobic bacteria (lower portions of the media often turned black indicating a reducing, anoxic environment). Progressive cementation of crystal bundles that had nucleated at the air/liquid interface

Figure 5. The four size-related hierarchical levels of features of bacterially induced precipitates. All four scanning electron micrographs are of the same precipitate from a laboratory culture, in broth, of Baffin Bay ooid bacteria at progressively higher magnifications. A) The bottom surface of a crust composed of crystal bundles. Crusts are visible with the naked eye. B) Individual bundles of crystals are visible with a hand lens or a binocular microscope. The bundles pictured here are semispherical. C) Each crystal bundle is composed of hundreds of individual crystals which are distinctly visible only with the use of an SEM. In this case, the crystals are in optical continuity so the entire crystal bundle goes to extinction as a unit. These dagger-shaped crystals are rather unusual and they closely resemble those of Given and Wilkinson (1985, figure 4B). D) Sometimes individual crystals are composed of small spheres or rods of calcium carbonate which are probably calcified bacteria. Because many of the bacterially induced precipitates are organic rich and porous, these features are at or near the upper limit of SEM resolution for this type of sample.



Figure 6. Scanning electron micrographs of crusts that formed during laboratory experiments. A-E were formed by Baffin Bay bacteria in broth media and F was formed by bacteria from Andros Island in gelatinous media. A) The surface of a crust composed of hemispherical bundles that formed at the air/liquid interface. Observe the flattened tops which resemble lilly pads and the radial arrangement of the crystals. The bottom of each hemisphere of which the crust is composed is rounded, much like those in Figure 5A. B) A lightly etched sample of the crust shown in A clearly displays the radial and concentric arrangement of the crystals which compose each hemisphere. Small depressions in the centers of the hemispheres are where precipitation initiated around clumps of bacteria. C) In some cases nucleation was so rapid that incomplete hemispheres formed and were cemented into the crust. These dumbbell-shaped crystal bundles will be discussed below in more detail. D) The bottom of a crust of crystal bundles. Crystals within each bundle are arranged in optical continuity so that crystal bundles display unit extinction. E) An example of dumbbells (arrow) which have formed a subaqueous crust (see Figure 8E for an enlarged view). F) Crusts were rare in most gelatinous media, however, crusts like this one were common in fresh-water gelatinous media made with CaCl_2 (see also Figure 4E, F). Crystal bundles nucleated and began to grow as rhombohedra (arrow) and those on the periphery, where there was less competition for the available Ca, were able to continue growing until they formed complete spheres (far right).

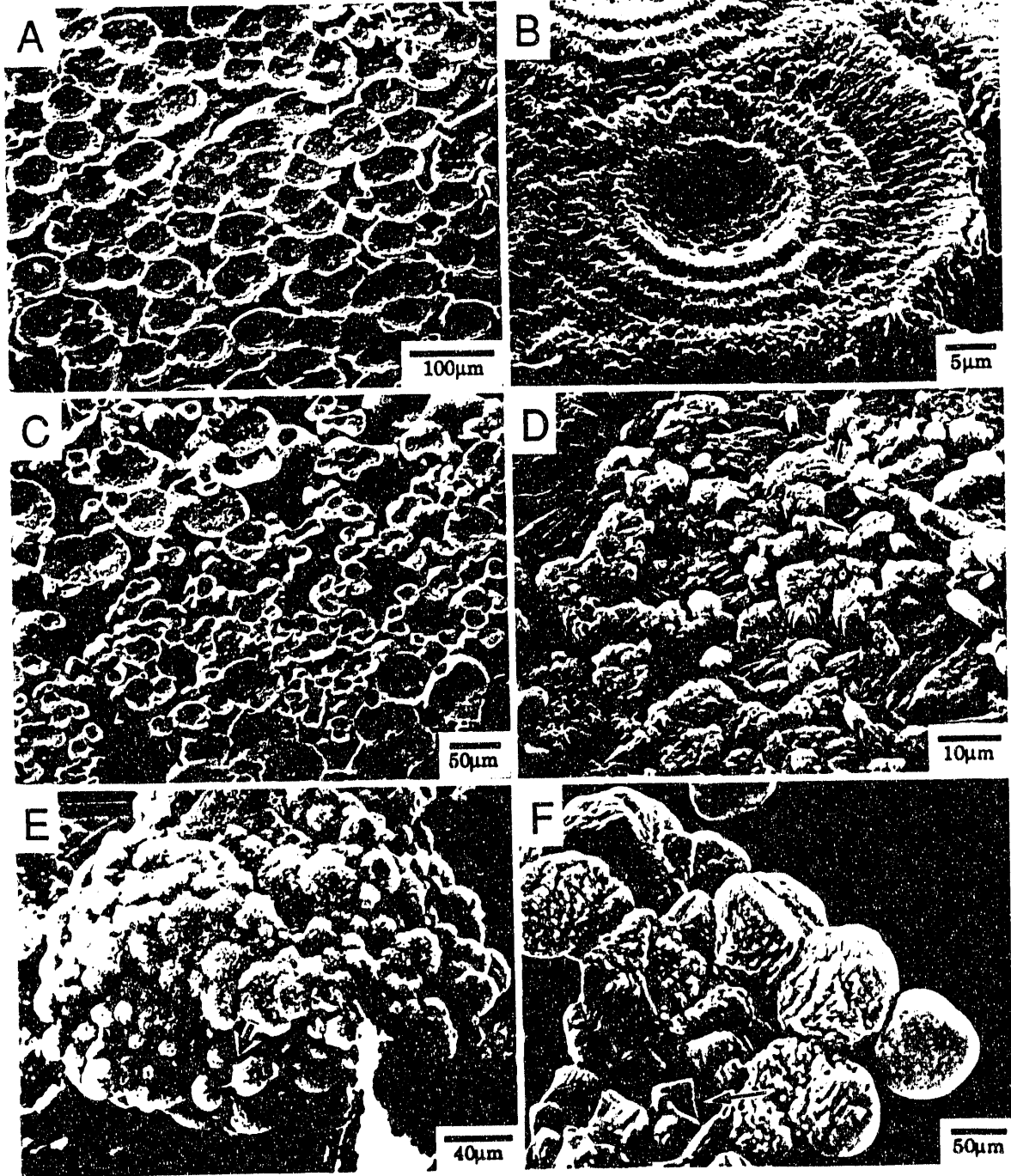

eventually created a crust that often covered the entire surface of the liquid. In cases where very few crystal bundles nucleated each could grow into a complete hemisphere before they became cemented together (Figure 6A, B). At sites of rapid nucleation and crystal bundle growth, incomplete bundles resembling dumbbells were cemented together to form part of the crust (Figure 6C). Most crusts are composed of hemispheres or spheres, however, some are composed of nonspherical crystal bundles (Figure 6D). Smaller, more robust accumulations of crystal bundles occurred in a few experiments. In some experiments with broth media, dumbbells formed crusts (Figure 6E). In crusts formed in gelatinous media with CaCl_2 added, the crystal bundles began as rhombohedra which, with continued growth, became spherical (Figure 6F). The spheres formed in areas where the bundles were not closely spaced, and toward the edges of the crust. It is speculated that in these areas, there was little "competition" for calcium and crystal bundle growth continued. In areas of high nucleation the medium became depleted with respect to calcium and the rhombohedra stopped growing. Why, exactly, continued growth produces spherical crystal bundles is not known.

Crystal Bundles and Individual Crystals

Common Forms

Discrete submicron-sized crystals form distinct bundles or aggregates which generally begin as rods and, if allowed to grow

unimpeded, form spheres. In some cases the individual bundles tended to form discs or shapes resembling rhombohedra, tetragonal disphenoids, and tetragonal dipyramids. These crystal bundle forms do not necessarily reflect actual crystalline calcite or aragonite forms. These submicron-sized crystals are always seen as part of an aggregate, they are never found as single, isolated crystals. It may be that individual crystals are small enough to be colloidal and, therefore, are not collected when broth media is centrifuged. It is also possible that they dissolve when samples are cleaned. The crystal bundles are found in every bacterially induced laboratory precipitate examined and they generally represent almost 100% of the precipitate.

Rods and spheres formed as end-members of a type of crystal bundle along with intermediate forms of these endmember morphologies. Rod-shaped aggregates commonly display additional growth at their ends to form the familiar dumbbell-shaped crystal bundles (Figure 7), a morphology which has been produced previously in laboratory experiments with bacterial cultures (Boquet et al., 1973; Ramos-Cormenzana, 1975; Krumbein, 1979b) and observed in samples from different natural environments (Piccoli et al., 1984, figures 42, 299, 300; Pursell, 1985, figures 33, 43-45; Kocurko, 1986, figure 6B; Bending and Folk, 1987; Buczynski and Chafetz, 1989; Chafetz et al., 1989). Further precipitation at the ends of dumbbells results in hemispheres or spheres (Figures 6A-C, & 7). A similar progression from rod to sphere was proposed for non-polymeric substances by Bernauer (1929, as noted in Keller, 1958). In experiments

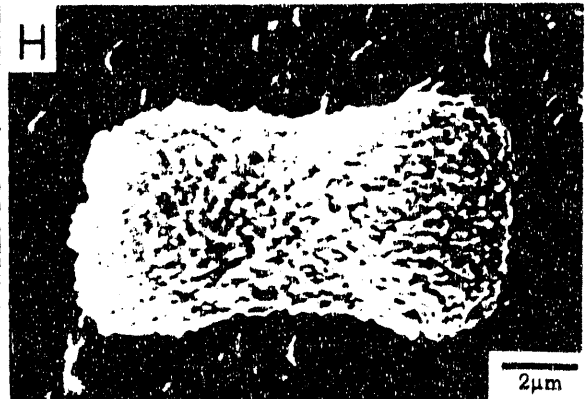
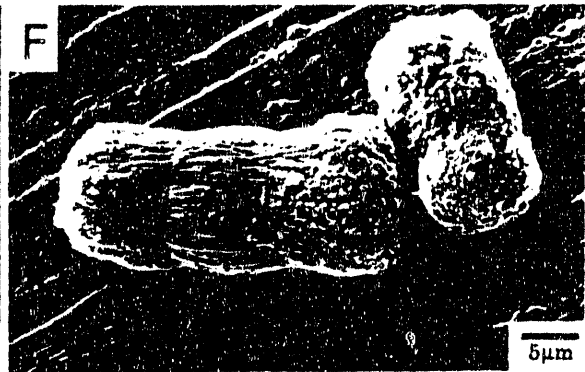
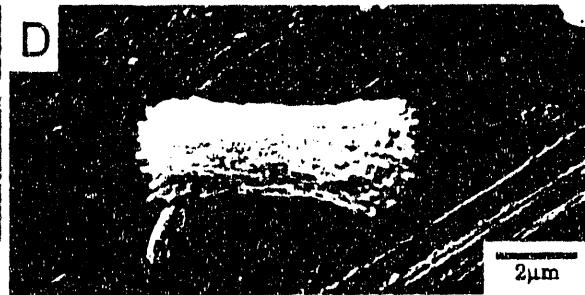
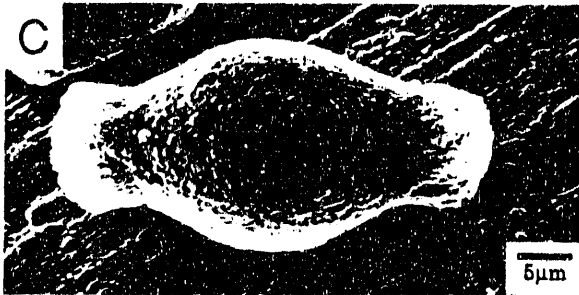
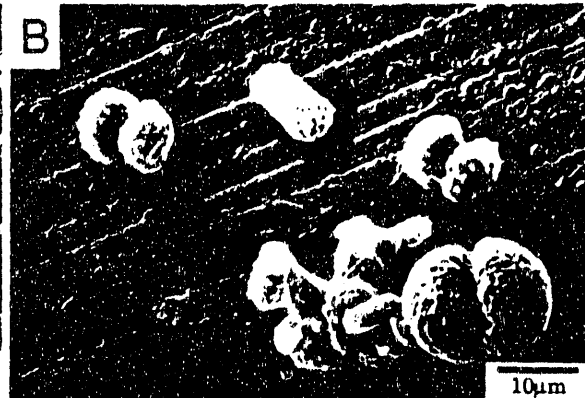

Figure 7. A scanning electron micrograph of several bundles of aragonite crystals from a laboratory precipitate formed in broth with Baffin Bay bacteria. All stages of the rod to sphere sequence of crystal bundle growth are represented, including numerous examples of the "dumbbell" form.

where crystal nucleation occurred on a substrate, such as the side of a glass jar, or at the air/liquid interface, a complete sphere could not form and the result was a hemisphere (Figure 6A-C). Spherical and hemispherical forms (including assorted spherulitic, pelleted, ooidal, and peloidal forms) have also been previously produced in the laboratory through bacterial action (Drew, 1911; Berkeley, 1919; Monaghan and Lytle, 1956; Lalou, 1957a, 1957b; Oppenheimer, 1961; Shinano and Sakai, 1969; McCunn, 1972; Krumbein, 1974, 1979b; Krumbein and Cohen, 1974, 1977; Ramos-Cormenzana, 1975; Krumbein et al., 1977; Morita, 1980; Novitsky, 1981; Moral et al., 1987; Buczynski and Chafetz, 1989) as well as recognized in natural environments (Monty, 1965, 1967, 1972, 1976; Urist, 1973; Krumbein and Cohen, 1974, 1977; Krumbein et al., 1977; MacIntyre and Videtich, 1979; Buchbinder, 1981; Druckman, 1981; Krumbein and Swart, 1983; Tsien, 1985; Chafetz, 1986; Jones and Ng, 1988; Chafetz et al., 1989).

Combinations of additional growth in the center and at the ends of the rods can produce a wide variety of forms of crystal bundles (Figure 8). One unusual variant of the growth sequence from the rod- to dumbbell-shaped morphologies produced rods which were thicker or "swollen" in the middle (Figure 8A, C, F). To date, these swollen rods have not been reported from other laboratories, and the only reported occurrence of a similar natural form seems to be that of Wind and Wise (1976, figures 22, & 23) which was found in the central canal of the peripheral spine of a mollusc. Although the gross form of the crystal bundles are similar, they are not identical.

Figure 8. Scanning electron micrographs of several shapes of dumbbells and rods that formed in response to bacterial activity under laboratory conditions. A-F formed in broth media and G & H formed in gelatinous media. A-H were all formed with Baffin Bay bacteria. A) The bottom of a crust with numerous dumbbells that were incorporated into it (the dumbbell "boat" (arrow) formed at the air/broth interface and is not in place). Observe that most of the dumbbells are thicker at the center than at the ends. B) Another sample which displays the rod to sphere sequence. In this case, the resultant "sphere" is more like two hemispheres stuck together than a sphere. Compare this to Figure 7. C) A close-up of a "swollen rod". At an earlier stage of formation they look like footballs, and, with continued growth, they commonly begin to flare out at the ends to form dumbbells. Slightly advanced stages of growth may be seen in Figure 8A, directly above. The "grainy" texture on the surface of this swollen rod is probably due to encrusted coccoid bacteria. D) A rod-shaped aggregate of aragonite crystals. E) A close-up of Figure 6F showing some of the individual dumbbells which compose the crust. Preferential growth of one lobe of the dumbbell is common in these forms. F) Rods which display incipient stages of growth in the center and at the ends. The elongated, semicylindrical "crystals" of which they are composed may be calcified bacillus bacteria. G) A calcite dumbbell formed in gelatinous media. Observe the blocky calcite crystals which compose the dumbbell. H) Another calcite dumbbell from gelatinous media. The crystal faces are poorly developed in this example.



As noted previously, each crystal bundle that makes up a rod, sphere, or intermediate form, whether it is composed of calcite or aragonite, is formed from hundreds of individual crystals (Figures 5B-D, 6B, D, E, F, 7, & 8C-H). The long dimension of rod-shaped forms is approximately parallel to the c-axes of the individual crystals that compose it (Figures 7, & 8D, F), or, in the case of spheres, the individual crystals are most commonly radially oriented (Figures 4D, 6A, B, & 7). Although in some spheres the individual crystals are in optical continuity (Figures 5B, C, & 6F). In the samples x-rayed, the aragonitic crystal bundles are most often composed of needle-like crystals (Figures 7, & 8D) whereas calcitic crystal bundles are most often composed of either equant or flattened rhombohedra (Figure 8G).

Crystal bundles of calcite which resemble rhombohedra, tetragonal disphenoids, and tetragonal dipyrramids often form in gelatinous media (Figure 9A, B). The crystal bundles are aggregates of individual crystals and, as such, the bundles do not necessarily reflect calcite crystal forms. Because of their size, individual crystals of which these bundles are composed cannot be resolved with a light microscope and the bundles appear as small rods, rhombohedra, or some other type of blocky crystal. Although their size makes exact crystallographic determinations difficult, the individual crystals within each bundle appear to be in approximate optical continuity, with their c-axes generally parallel to the long dimension of the bundle. Some of these crystal bundles which formed in

Figure 9. Scanning electron micrographs of both laboratory formed and naturally occurring crystal bundles. A) Crystal bundles of calcite encrusted dead cyanobacterial filaments which were placed in gelatinous media in a laboratory experiment with Baffin Bay bacteria. This sample has been treated with 30% H_2O_2 to remove organic matter. Observe that the crystal bundles have been cemented to form a rigid crust which does not depend on the organic matter for support. B) A close-up of some of the laboratory formed crystal bundles from A (area of close-up not from field of view shown in A). These bundles sometimes resemble rhombohedra, tetragonal disphenoids, or tetragonal dipyrramids. C) Crystal bundles formed in the gelatinous secretions produced by cyanobacteria in Fresh Creek, Andros Island, and encrusted cyanobacterial filaments which have since been removed with 30% H_2O_2 . D) A close-up of the naturally produced crystal bundles that formed in gelatinous material around cyanobacteria (area of close-up not from field of view shown in B). In some cases the material produced in the laboratory and in nature are indistinguishable, from the very small scale features (individual crystal bundles) up to the morphology of encrusted filaments.

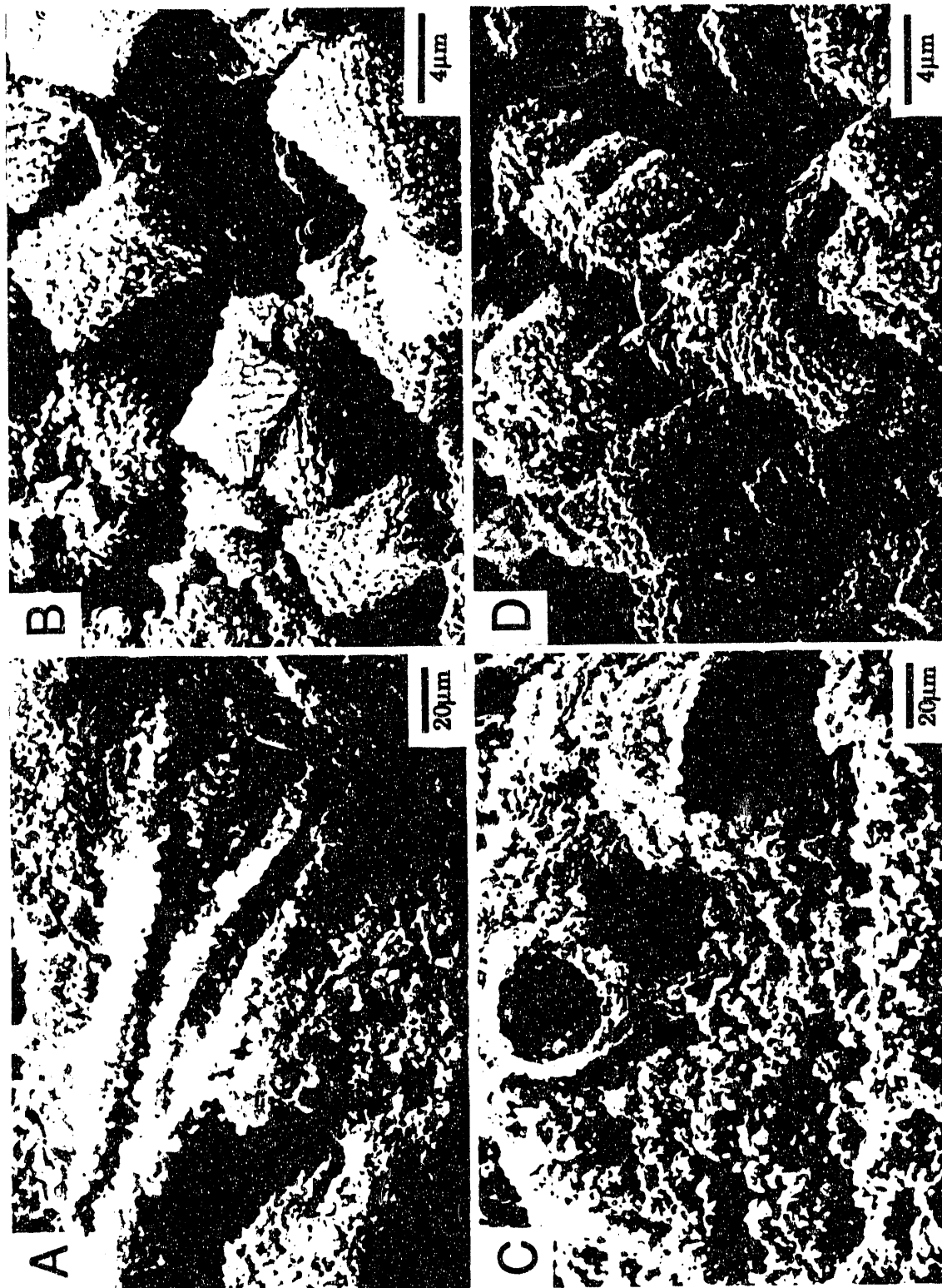

the laboratory have identical counterparts in naturally occurring samples from Andros Island (Figure 9C, D). In the laboratory, these crystal bundles formed only in gelatinous media, and, on Andros Island, they formed within the viscous mucilage secreted by bacteria and cyanobacteria that compose the algal mats described above. Similar forms from natural environments were also noted by Wind and Wise (1976, figure 12), Schneider (1977, figure 2/4), and Borowitzka (1982b, figure 1). Although they do not all attribute these forms directly to bacteria, the environments in which they were found would almost certainly contain numerous bacteria.

Unusual Forms

The crystal bundles resembling rhombohedra, tetragonal disphenoids, and tetragonal dipyrramids, and the progression of rod to sphere encompass the most frequently observed forms of bacterially induced precipitates of calcium carbonate from laboratory experiments and natural environments. In addition, aragonite needles have been produced in other laboratory experiments. Discs, brushes, "smooth" rods, and "smooth" dumbbells, which are unlike previously reported precipitates, have been formed in the laboratory during the course of this research. Thin discs composed of optically continuous crystals formed only in gelatinous media with CaCl_2 added (Figure 10), but they are formed by bacteria from both Baffin Bay, and Andros Island, and their genesis within microns of distinctly different crystals makes a case for the existence and influence of

Figure 10. Scanning electron micrographs of the calcite discs that formed in fresh-water gelatinous media with CaCl_2 added as a calcium source. The sample was boiled in 30% H_2O_2 to remove organic matter, and lightly etched. A) The surface resembles the flattened surface of some hemispheres but the disc is only approximately $20\mu\text{m}$ thick, and individual crystals are in optical continuity over large areas of the disc. These discs were scattered among the crystal bundles pictured in Figure 6F, but they were far less abundant. B) A close-up of the lower right portion of the disc showing the numerous holes left by bacteria which were removed by the H_2O_2 . The small rods sticking up may be calcified bacteria. A similar surface texture is observed when the rhombohedra pictured in Figure 6F are etched.

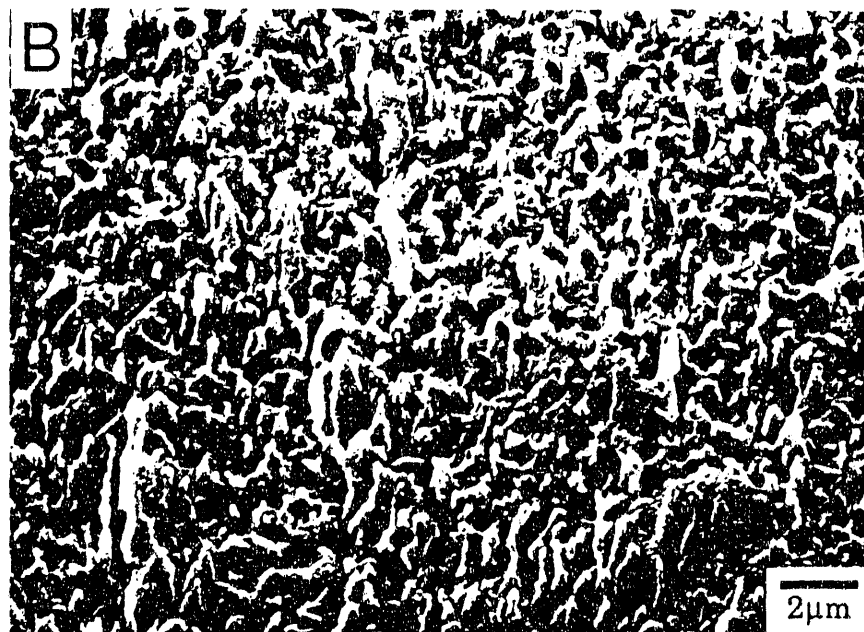
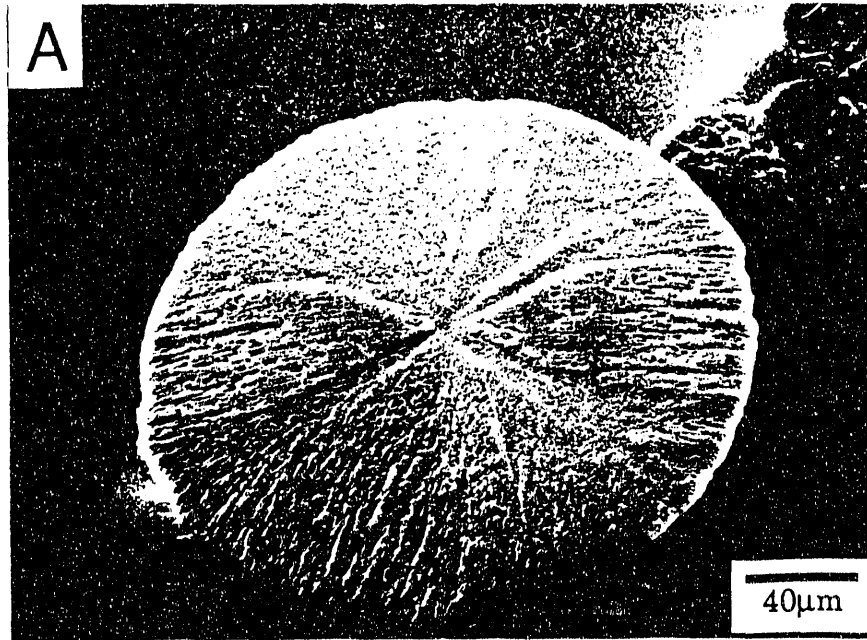

microenvironments on crystal formation. They resemble the flat surface of hemispherical forms produced in other cultures during this research as well as those produced by Danielli and Edington (1983, figure 2F).

In most cases, crystal bundles do not display smooth curved surfaces. However, several laboratory precipitates of dumbbells and swollen rods have been observed with such surfaces (Figure 11). On closer examination, it can be seen that these forms are composed of 0.1-0.4 μ m diameter spheres or rods of calcium carbonate. These dumbbells and swollen rods have not been reported from other laboratories and only one occurrence of a swollen rod has been reported from a natural environment (Wind and Wise, 1976, figures 22, & 23). As with their counterparts, the long dimension of the rod or dumbbell is parallel to the c-axis of the individual crystals of which it is composed.

May and Perkins (1979, figures 2, & 3) have photographed boring endoliths which very closely resemble these smooth dumbbells, as well as some which resemble spheres and hemispheres. It is possible that bacteria of a similar shape were present in some cultures from this research, and that precipitation proceeded around them to create the smooth dumbbell form. However, no bacteria of the dumbbell shape have been seen in slides of stained cultures from these experiments.

In one experiment with a broth culture of bacteria collected from a Baffin Bay ooid accumulation, extremely unusual crystals were produced (Figure 12). In three dimensions, the crystals appear to be arranged like bristles on a brush. In thin section, only a cross section can be seen and

Figure 11. Scanning electron micrographs of a "smooth" dumbbell and "smooth" swollen rod formed in broth media with Baffin Bay bacteria. A) A smooth dumbbell. B) A close-up of the right lobe of the dumbbell pictured in A showing the relatively smooth surface. Observe the lack of angular crystal faces. C) A close-up of B showing the almost organic appearance of the dumbbell surface. Observe that it is composed of spheres which may be calcified coccoid bacteria. D) A smooth swollen rod which is composed of elongated, semicylindrical "crystals" which may be calcified bacillus bacteria. Also see Figure 8F for an additional example.



Figure 12. Examples of brush crystals formed in broth media by bacteria from Baffin Bay ooids. A & B) Plain and crossed polar thin section photomicrographs, respectively, of brush-type crystals. They more closely resemble combs when broken into fragments, as they are here. C-E) Additional thin section photomicrographs of brush crystals. Observe the variation in both "bristle" length, and the angle between the bristles and the base in A-E. F & G) Scanning electron micrograph of a portion of the "base" of the brush showing the convoluted network of which it is composed. Most of the bristles have been broken off. H) A close-up of G showing the small spheres of which it is composed. These spheres may be calcified coccoid bacteria. Compare with Figures 5D, 8C, & 12C.

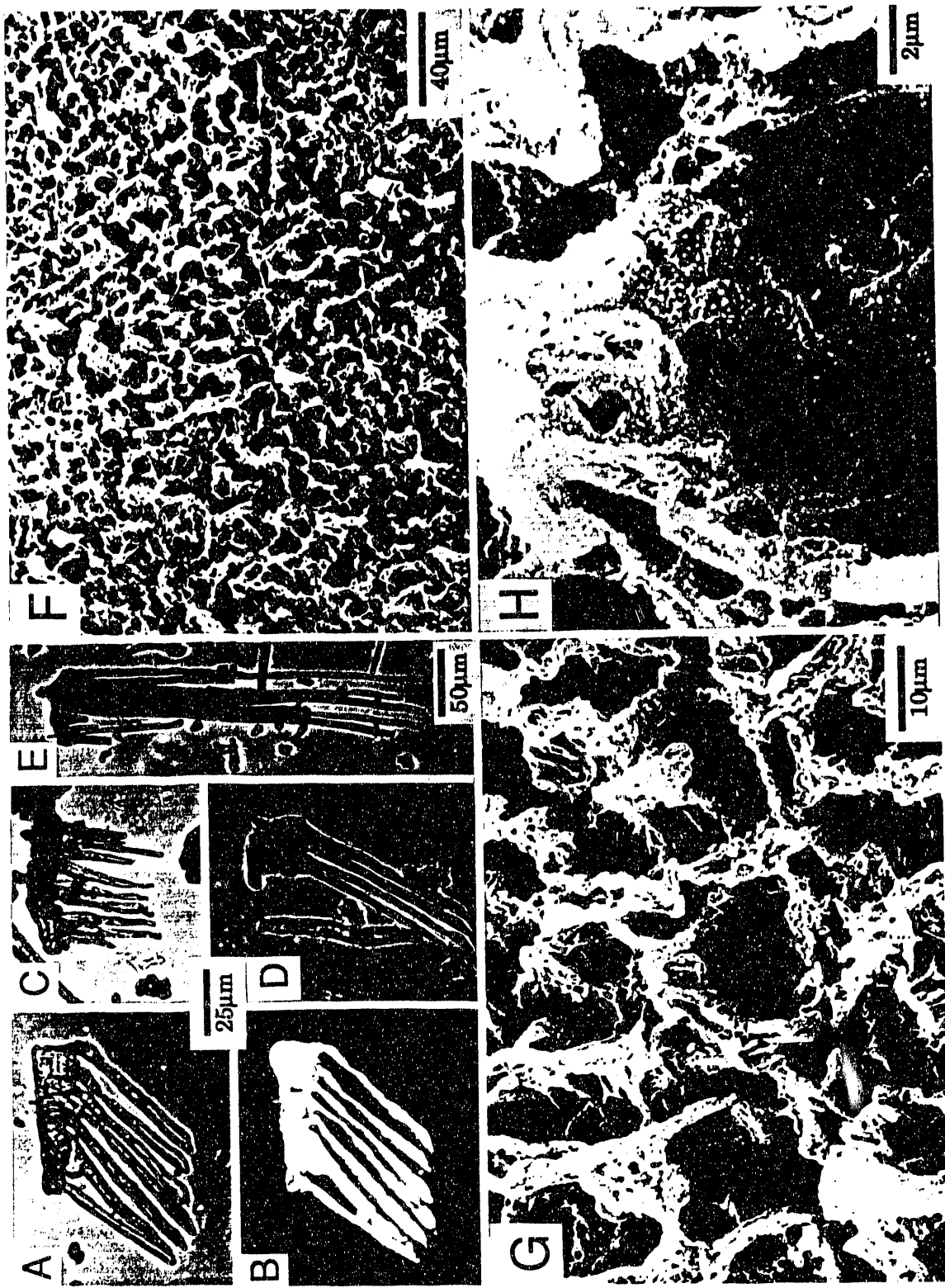

they resemble a comb. The base and the "bristles" are in optical continuity and they appear to be part of a single large crystal (Figure 12A, & B). The bristles are arranged in an orderly grid and both their length and their angle to the base is always the same within an individual crystal, but ranges between different crystals (Figure 12A-E). Part of the range in the base to bristle angle may simply be a reflection of the plane of fracture through the brush. An SEM micrograph shows the base to be a porous, convoluted, meshwork which is composed of numerous spherical objects (Figure 12F-H). In contrast with the base, the "bristles" appear to be part of a single crystal and not composed of spheres.

These brushes could possibly form on an organic meshwork of filamentous bacteria in the following manner. After the experiment is inoculated, a variety of bacteria grow rapidly over the surface of the culture media. This is an optimum site because the bacteria are kept moist and nourished by the medium, and the atmosphere provides a readily available source of oxygen. The filamentous bacteria form an organic meshwork over the entire surface of the container (Figure 13A). Calcification of the organic film begins and the precipitate follows the form of the tangled mass of bacteria. Complete calcification does not seem to occur, possibly because of a lack of liquid movement through the meshwork which would provide the necessary calcium ions. After the meshwork begins to calcify, abiotic precipitation takes place at the base of the forming crust and it proceeds with the "bristles" growing down into the liquid (Figure 13B). In cases where the film is undisturbed the bristles continue to grow downward from

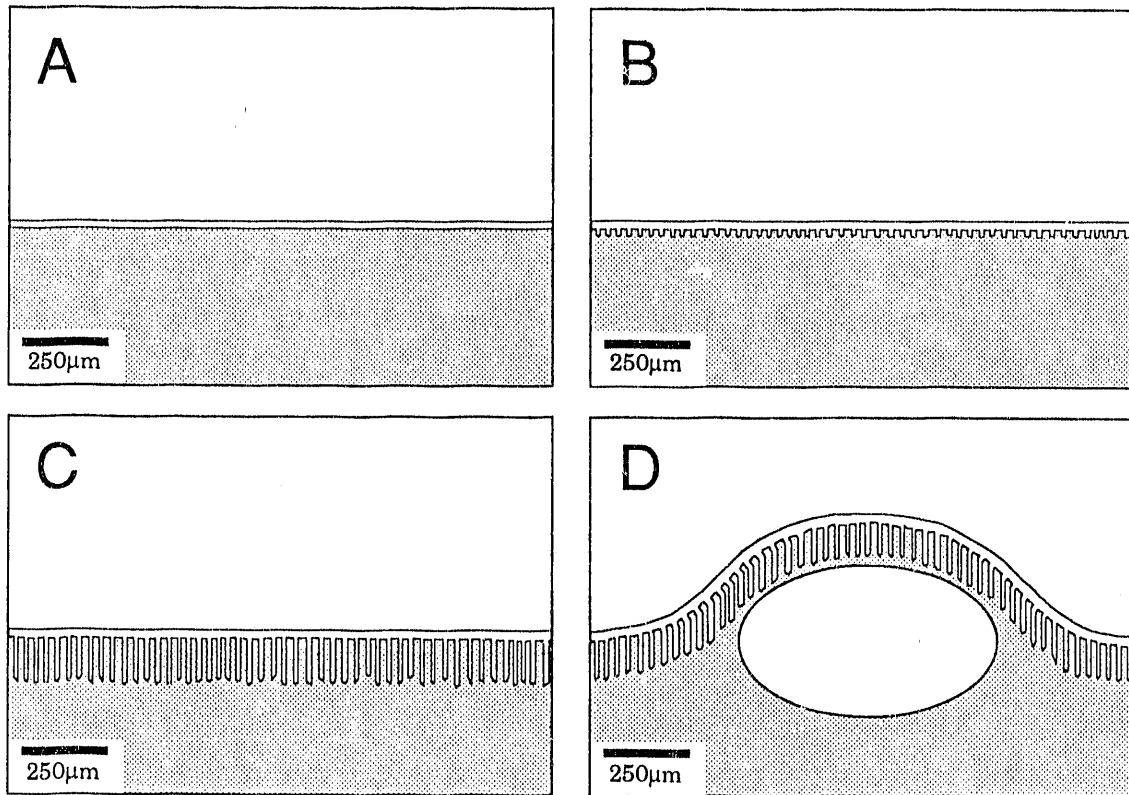

Figure 13. A) Filamentous and coccoid bacteria form a biotic film over the surface of the liquid culture media. B) The biotic film begins to calcify and the precipitate follows the form of the tangled mass of bacteria. At about the same time, abiotic precipitation takes place at the base of the forming crust. C) If the film is undisturbed the bristles continue to grow downward from the calcifying crust. D) Gas bubbles generated by bacterial action can rise to the surface, distort the growing film, and change the direction of growth of the bristles.

the calcifying crust, and crystals like those in Figure 12C, E form (Figure 13C). When gas bubbles generated by bacterial action sometimes rise to the surface, distort the growing film, and change the direction of growth of the bristles, crystals like those pictured in Figure 12A, D would form (Figure 13D). The disturbance of the organic meshwork by bubbles could account for both the observed range of the angle between the bristles and the base as well as the observed range of relative extinction angles of the bristles (Table 1). In general, as the extinction angle of the base increases, the minimum angle between the base and the bristles decreases. In all cases extinction of the bristles, as measured in the horizontal plane of the microscope stage, occurs at an equal or smaller angle than extinction of the base. However, this does not explain why nucleation of the bristles would occur in such a regular pattern, nor why precipitation in the base, at least on the order of the size of the brush fragments observed, occurs in optical continuity.

Submicron-Sized Spherical and Rod-Shaped Components

The crystal bundles which form rounded swollen rods and dumbbells, some spheres, and the base of the brushes described above are composed of 0.1-0.4 μ m diameter spheres or rods of calcium carbonate (Figures 5D, 8C, F, 11C, D, 12G, & 14). These spheres and rods probably represent individual coccoid, and bacillus bacteria, respectively, which have become entombed in calcium carbonate. Similar features have been observed in laboratory and natural environments (Danielli, 1981, figure 4D,

	extinction angle between horizontal and base in degrees	extinction angle between vertical and bristles in degrees	angle between bristles and base in degrees	bristle length in microns
1	0	0	90	68
	0	0	90	124
	0	0	90	128
	7	5	88	40
	7	7	90	120
	10	0	80	72
2	11	5	84	200
	15	8	83	120
	16	16	90	45
	18	10	82	12
	20	7	77	72
	34	0	56	20
3	44	22	68	100
	44	23	69	200
	51	39	78	100
	56	0	34	128

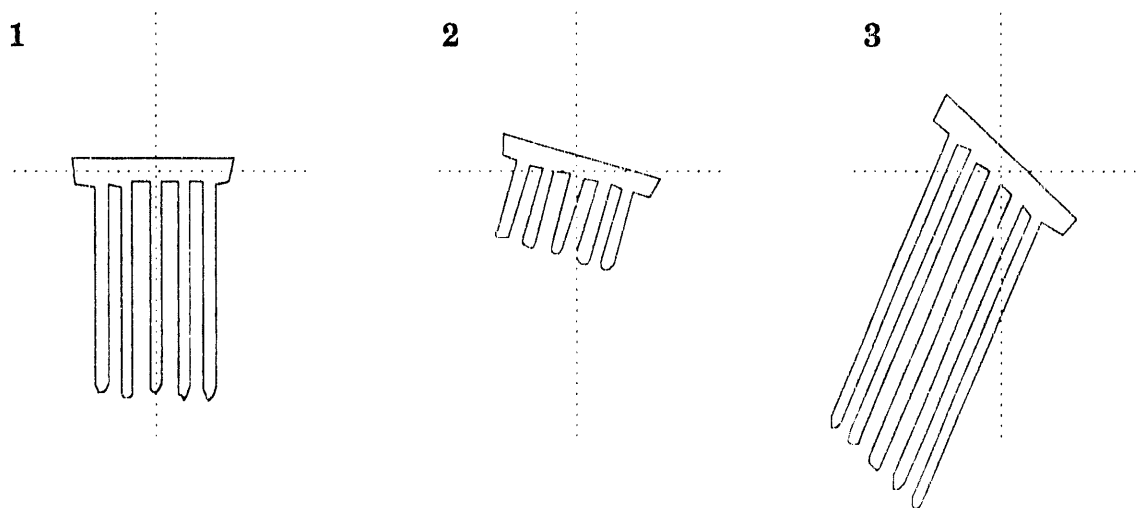
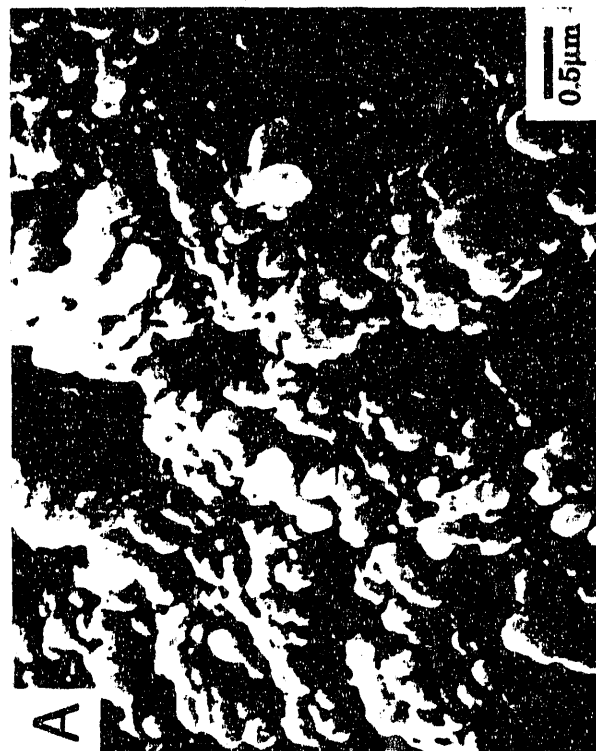
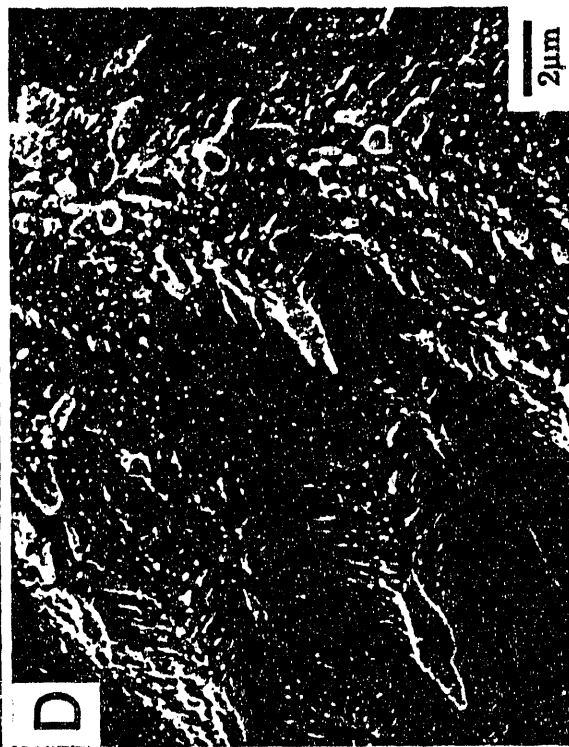

Table 1. List of brush crystal characteristics. The error in measurement of the angle between the base and the bristles is approximately $\pm 3^\circ$. Crystals with bristle lengths of less than about $70\mu\text{m}$ had generally been broken. Samples labeled 1-3 are shown schematically in the orientation they would be in at extinction.

Figure 14. Scanning electron micrographs of spherical- and rod-shaped forms in nature and the laboratory which may be calcified coccoid and bacillus bacteria. A & B) Lightly etched samples from the L7 collection site, San Salvador, showing spherical- and rod-shaped forms, respectively. C) Rod-shaped forms from a Baffin Bay sample. D) Rod-shaped forms from a laboratory precipitate formed in gelatinous media (close-up of Figure 6F). Compare with Deelman (1975b, figure 1), Flajs' (1977, figure 2/2) photograph of calcareous red algae, and Chafetz (1986, figure 2B). The hollow areas are precipitates that formed around bacteria. The individual rods may, or may not represent encrusted bacteria.



E; Golubic and Campbell, 1981, plate II, #5; Camoin and Maurin, 1988, figures 1, & 6) and some have been attributed to bacterial activity (Krumbein et al., 1977, figure 12E; Klappa, 1979, figure 3A).

Factors Influencing Crystal Bundle Forms

How and why these small spheres of calcium carbonate align to create crystalline forms which, in turn, form swollen rods, smooth dumbbells, spheres, hemispheres, and brushes is not known, but these forms appear to be uniquely bacterial in origin. In general, the precipitate in a given container is homogeneous. For example, the aragonite dumbbells and hemispheres shown in Figure 7 have not been observed to occur with those shown in Figure 12. There does not appear to be any correlation between the shape of the precipitate and light, temperature, or nutrient type and abundance, although other workers have found that several factors including organic matter, salinity, Mg^{+2} concentration, and the cyanobacterial makeup do affect the form and/or mineralogy of the resulting precipitate (Monaghan and Lytle, 1956; Zeller and Wray, 1956; Kitano, 1962a, 1962b, 1964; Kitano and Hood, 1965; Kitano et al., 1970; Towe and Malone, 1970; Folk, 1974; Berner, 1975; Shinano and Sakai, 1975; Kitano et al., 1976; Walter, 1986; Moral et al., 1987; Ferrer et al., 1988). The calcium source did, however, make a difference in experiments conducted here, and, as previously noted, discs and crusts in gelatinous media were only produced when $CaCl_2$ was used as a calcium source in fresh-water

media (Figures 6F, & 10). Very similar crystals were obtained by Hewitt (1947) with sputum bacteria.

It should be stressed here that although several different types of media were often inoculated at the same time from a single mixed culture of bacteria, there is no assurance that the resulting cultures were identical. Hence, differences in bacterial populations cannot be excluded as a cause for the variety of precipitates observed and bacterial composition may have made a difference in some experiments. However, as bacteria from different sources (within and between different laboratories, and under varied conditions) frequently produced the same forms of crystal bundles, it is believed that most bacteria do not substantially influence the mineralogy and geometry of passively induced precipitates. This should be particularly true with mixed cultures where the precipitate may be influenced by two or more strains of bacteria.

ABIOTIC AND CONTAMINANT PRECIPITATES

Some abiotic and mould/bacterial precipitates of calcium carbonate were formed during this research due to the slow drying of a gel with twice normal marine salinity, and contamination of a control flask with mould and bacteria. In the first case, gelatinous media of twice normal marine salinity had been prepared. The petri dishes were left in a hood and as air was constantly drawn past them, they began to dry. Plates both with and without bacteria developed a uniformly distributed precipitate which spread

from the edges of the petri dishes toward the center as drying proceeded (Figure 15A, B). In the other case, at the end of an experiment, one control bottle containing broth was contaminated with mould and bacteria during a pH measurement and then allowed to remain some weeks before being cleaned out. A floating crust of calcium carbonate, mould, and bacteria resulted (Figure 15C-F). These precipitates are quite different from those that formed exclusively due to bacterial action. In the first case, both the form and the distribution of the precipitate distinguish it from a bacterially induced precipitate. Even when it occurred in the presence of bacteria its distribution was not related to the bacteria. In the second case, there could potentially be some confusion. It is not known what significance the mould played in the precipitational process and whether precipitation would even have occurred in the absence of the bacteria. However, the imprint of the mould filaments in the precipitate (Figure 15D, & F) clearly indicate the presence of the mould.

MINERALOGY

A striking relationship was observed between the medium viscosity, the form of individual crystals, and the mineralogy of the precipitate in the laboratory. Where mineralogy could be determined, in most cases, calcite precipitated in the viscous agar media and aragonite precipitated in the liquid media. The mineralogy has been confirmed by XRD analyses when sufficient precipitate was available; three samples of calcite, three of

Figure 15. A) A scanning electron micrograph of an abiotically produced precipitate that formed by evaporation of gelatinous media of twice normal marine salinity. The crystal bundles resemble mushroom caps and they formed just under the surface of the gel in the orientation pictured, with the "gills" of the mushroom facing upward. B) A close-up of the crystals which compose the gills. C-F) Scanning electron micrographs of a crust formed in broth which was contaminated by mould and bacteria. The sample was soaked in 30% H_2O_2 to remove organic matter. C) The top surface of the crust which formed at the base of a floating clump of mould. D) A close-up of C (at arrow) showing the convoluted structure of the precipitate which formed around the filamentous mould. E) The bottom surface of the crust displays well-developed spheres and hemispheres. F) The impressions left by the mould filaments as well as the small spheres that are probably calcified coccoid bacteria can be clearly seen in this close-up of the center sphere pictured in E. These impressions from the mould filaments are too small to be confused with most filamentous cyanobacteria or algae, however, they could conceivably be confused with filamentous bacteria. The texture of the surface of the crust could serve to distinguish between the two possibilities in such cases.

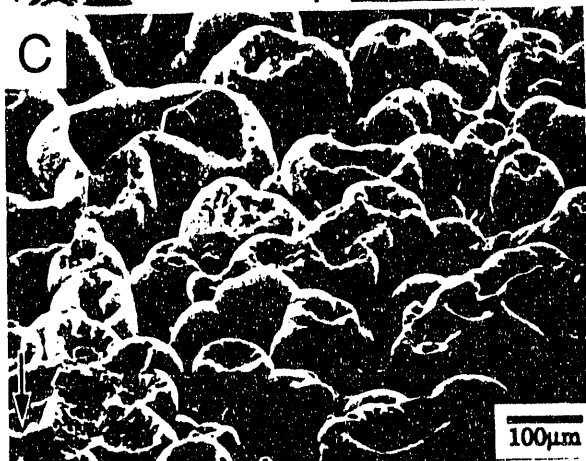
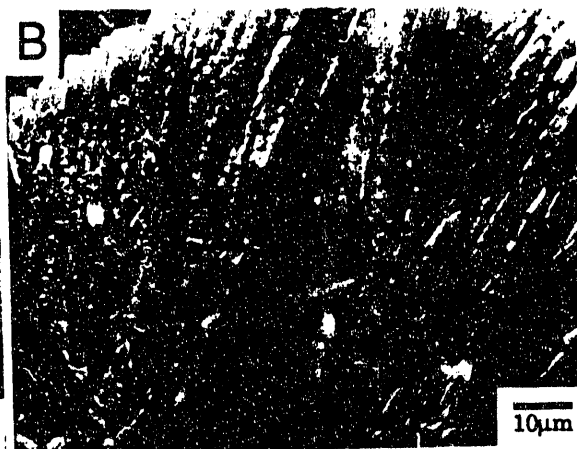

aragonite, and four of mixed composition (Table 2). Mineralogy has also been confirmed by staining with Feigl's solution followed by examination in the SEM. In several cases both liquid and gelatinous media were prepared from the same batch of nutrient broth and inoculated at the same time, from the same bacterial culture. During the course of the experiments the broth and gel cultures were placed in a hood next to each other. Consequently, light, temperature, nutrients, and initial bacterial composition were identical, so the results could be directly attributed to the viscosity of the medium. Where only calcite or aragonite formed they did so in gelatinous and liquid media, respectively. In some cultures agarophilic bacteria (those that can degrade the agar gelling material in the medium) caused the gel to liquify. When these bacteria were mixed into the gel before it became firm, both aragonite and calcite were present in the precipitate. Based on x-ray diffraction analyses, it was determined that there was a higher percentage of calcite in the fine-grained precipitate that formed throughout the gel, and at its surface. Crusts, which were primarily aragonite, formed at the air/liquid interface when the gel liquified, further cementing incipient calcite crusts.

Although the individual crystals retained their classic blocky and needle-like morphologies associated with calcite and aragonite, respectively, the aggregate morphologies of the rod to sphere progression of the precipitates were the same regardless of the mineral composition (Figure 16). That is, when all other variables were held constant, rods of aragonite were produced in the liquid media whereas rods of calcite

Bacteria source	Broth medium	Gel medium	% Aragonite	% Calcite	Mole % Mg	Ca source	Additions/Comments
Baffin Bay	B		100	0	-	seawater	dead algae, TMAO
Baffin Bay	B		100	0	-	seawater	live algae, TMAO
Baffin Bay	B		100	0	-	seawater	KNO ₃
Baffin Bay		G	0	100	0	seawater	live algae
Andros		G	0	100	0	CaCl ₂	TMAO
Andros		G	0	100	0	CaCl ₂	
Baffin Bay	B		98	2	0	seawater	
Baffin Bay	B		64	36	17	seawater	live algae, TMAO
Baffin Bay		G	95	5	5	seawater	KNO ₃
Baffin Bay		G	85	15	0.5	seawater	fine fraction
Baffin Bay		G	93	7	12	seawater	coarse fraction

Table 2. X-ray diffraction data for ten laboratory precipitates (the last two measurements are different size fractions of the same sample). The basic nutrient medium for all samples was 2216E. Proportions of calcium carbonate isomorphs were estimated based on the area under the 29.43° calcite peak, and the 26.24° aragonite peak. Mole % Mg in calcite was estimated based on the offset of the 29.43° peak (Scholle, 1978).

Figure 16. Scanning electron micrographs showing bacterially induced precipitates of *aragonite* formed in liquid media (A, C, E, G) and *calcite* formed in gelatinous media (B, D, F, H) from laboratory experiments with Baffin Bay bacteria, and from nature. A & B) Crusts of hemispheres from laboratory precipitates composed of aragonite (left) and calcite (right). C & D) Close-ups of A & B, respectively, showing the overall similarity of the ultrastructure of the crystal bundles. E & F) Examples of an aragonite dumbbell (see also Figures 7, & 8D, E) and a calcite dumbbell (see also Figure 8G, H), respectively, precipitated in the laboratory. G) An aragonite dumbbell formed naturally in travertine precipitating waters (photograph courtesy of Dr. H. S. Chafetz). H) A calcite dumbbell formed naturally within a gelatinous secretion of bacteria and algae, collection site L7, San Salvador, Bahamas (Figure 2C). Compare with figure 5.2 of Pentecost and Riding (1986).

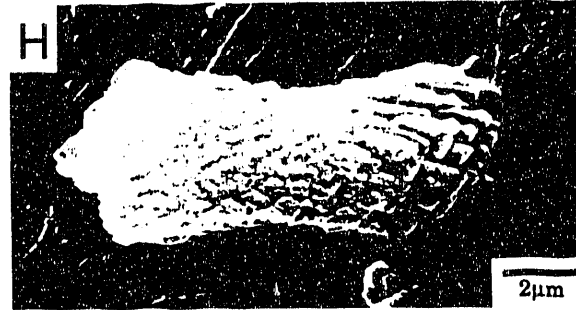
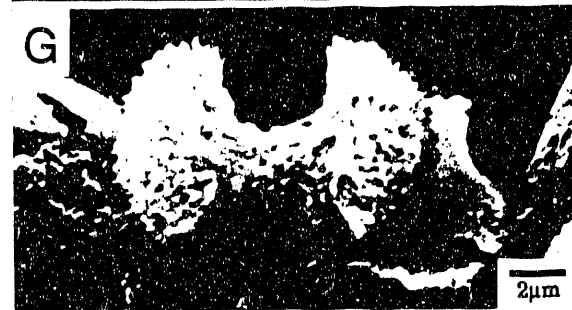
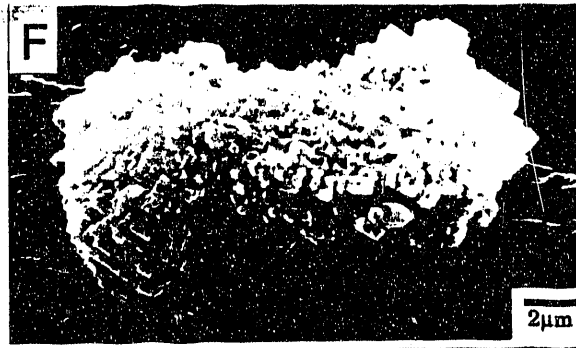
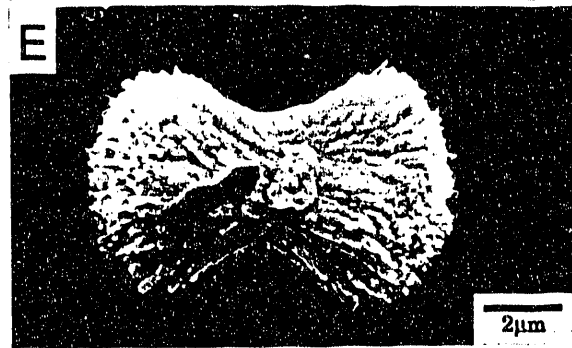
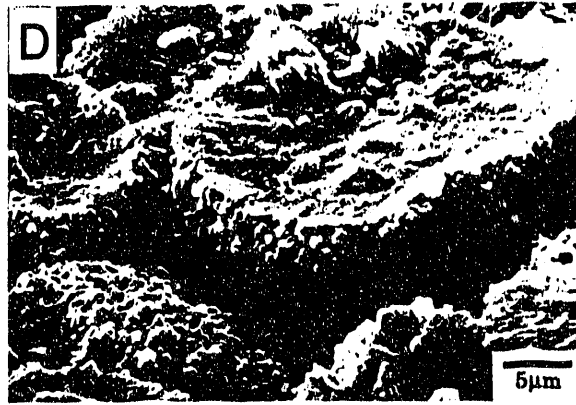
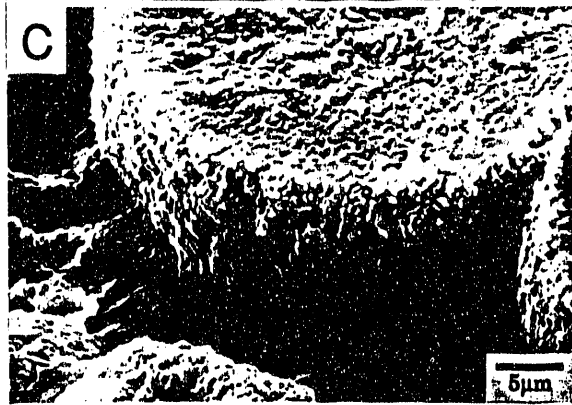
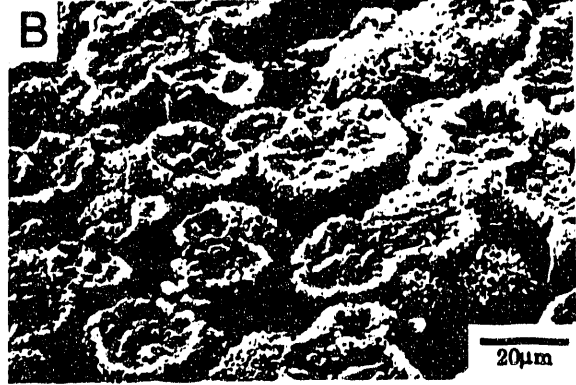
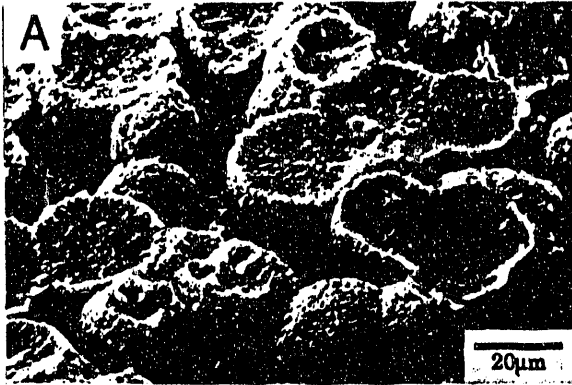

precipitated in the corresponding viscous media, similarly, spheres of aragonite precipitated in the liquid media and spheres of calcite in the corresponding viscous media. There were, however, no analogs to the brushes in gelatinous media, and no analogs to the crystal bundles which resemble rhombohedra, tetragonal disphenoids, and tetragonal dipyrramids in liquid media.

It has been postulated that the rate of precipitation of calcium carbonate can influence the mineral composition of the precipitate (Kitano, 1964; Kitano and Hood, 1965; Bathurst, 1975; Given and Wilkinson, 1985). In the laboratory, precipitation of calcium carbonate invariably occurred more rapidly in liquid media than in gelatinous media, all other things being equal. Although there are other factors which influence the composition of the precipitate (Monaghan and Lytle, 1956; Zeller and Wray, 1956; Kitano, 1962a, 1962b, 1964; Kitano and Hood, 1965; Kitano et al., 1970; Towe and Malone, 1970; Folk, 1974; Berner, 1975; Shinano and Sakai, 1975; Kitano et al., 1976; Walter, 1986; Moral et al., 1987; Ferrer et al., 1988), in these experiments, the viscosity of the medium seems to be the overriding control. In a liquid medium, ionic mobility is high and ions can be readily transported to the site of crystal nucleation. Precipitation occurs rapidly and aragonite forms (Figure 16A, C, E, G). In viscous media, such as agar or the gelatinous slime secreted in copious quantities by some microbial communities, ionic movement is slow (Monty, 1972), and, consequently, ionic availability is low, and calcite is precipitated (Figure 16B, D, F, H).

There are examples of this from natural environments. Crystal bundles of aragonite were found in an actively forming travertine spring deposit (Chafetz et al., 1989): they formed in warm, bacteria-rich, highly supersaturated waters. These crystal bundles closely resemble laboratory precipitates (Figure 16E, & G). Crystal bundles that had formed naturally in gelatinous material secreted by bacteria and algae were collected from the L7 locality, San Salvador, Bahamas, and from Fresh Creek and Ginette Pond localities, Andros Island, Bahamas (Figure 2B, & C). These crystal bundles are calcite and, again, they closely resemble those precipitated from gelatinous media in the laboratory (Figure 16F, & H). In addition, Folk (personal communication) observed that both aragonite and calcite formed in close proximity to each other in a travertine precipitating hot spring from Viterbo, Italy. Again, the aragonite formed in the liquid portion of the environment and the calcite formed in gelatinous secretions of bacteria and/or algae.

The magnesium content of calcite precipitates, estimated based on the shift in the 29.43° peak, ranged from 0-17 mole % (Table 2). In the sample containing 17 mole % Mg, a few of the individual crystal bundles displayed a well developed concentric banding (Figure 17). The more resistant bands contained significant amounts of Mg and the less resistant bands did not contain any measurable Mg (the sample was heavily gold coated which may have hindered the measurement of small amounts of Mg). A large amount of calcite in a broth medium (36%) was only found in one of the samples analyzed by XRD. In addition to 2216E, the nutrient

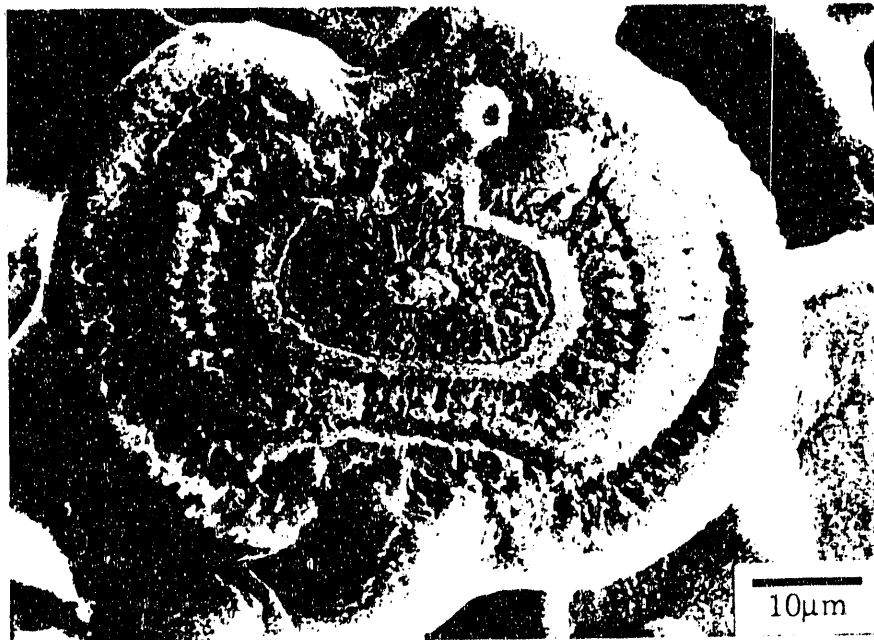

Figure 17. A scanning electron micrograph of an acid etched crystal bundle formed in broth media with Baffin Bay bacteria. The more resistant layers are approximately 17 mole % magnesian calcite (based on XRD analyses of a bulk sample, and EDAX analyses of the bands in the grain pictured), and the less resistant layers are aragonite.

medium also contained live algae (cyanobacteria) and TMAO. An identical experiment which was aerated produced 100% aragonite. The aerated experiment also resulted in the most rapid formation of a precipitate of any experiment. It would appear that, in this case, the rate of precipitation and the presence of live algae and/or TMAO influenced the precipitate mineralogy more so than the medium viscosity.

THE ROLE OF CYANOBACTERIA

The relationship between bacteria and cyanobacteria on algal tidal flats in which the algal mat is progressively buried and subsequently decomposed by bacteria was probably first noted in print by Black (1933a). Krumbein and Swart (1983) have reported that 99% of the organic material produced at Solar Lake (Sinai) is degraded by bacteria yearly. In some cases this decomposition leads to precipitation and/or cementation of calcium carbonate grains. This process of organic decomposition and calcium carbonate precipitation is either hinted at or stated directly by many authors (Greenfield, 1963; Monty, 1965, 1967; Dalrymple, 1965; Golubic, 1973, 1976a; McKirdy, 1976; Krumbein and Cohen, 1974, 1977; Horodyski et al., 1977; Krumbein et al., 1977; Jorgensen and Cohen, 1978; Krumbein, 1978, 1979b; Buchbinder, 1981; Druckman, 1981; Krumbein and Swart, 1983; Lyons et al., 1984; Pratt, 1984; Kocurko, 1986; Braithwaite et al., 1989). Cyanobacteria (blue-green algae) were used as a food source in some of the experiments to test the effects of microbial decomposition. Both live

and dead cyanobacteria were used, as noted above. Live cyanobacteria were not sterilized to destroy bacteria that are always present as all simple, readily available methods would also kill or significantly alter the cyanobacteria. Dead cyanobacteria were steam sterilized in an autoclave, however this clearly alters the quality of the food source, and, consequently, material prepared in this way is not chemically identical to cyanobacteria that died a natural, peaceful death. Bearing these problems in mind, a variety of different approaches were used.

Dead (sterilized) cyanobacteria were put into broth media and inoculated by the addition of live cyanobacteria, which contained bacteria, to examine the effects of bacteria on both live and dead cyanobacteria. Clumps of the live cyanobacteria were then examined for filaments that had died naturally and these were inspected carefully to see if they responded differently to bacterial decomposition than did sterilized cyanobacteria. Live and dead cyanobacteria were introduced into separate containers in both liquid and gelatinous forms of several varieties of growth media, buried in an assortment of sediments in an attempt to determine if bacterial activity differed in the sediment column, and used as the sole food source in some experiments.

The most significant result from these various experiments is that bacterially induced precipitation of calcium carbonate occurs on both live and dead cyanobacteria in both broth and gelatinous media, however, it invariably occurs more rapidly and is considerably thicker on dead cyanobacteria (Figure 18). No precipitation occurred on dead, sterilized

Figure 18. A & B) Scanning electron micrographs of dead, sterilized cyanobacterial filaments which were inoculated with Baffin Bay bacteria, placed in broth and gelatinous media, respectively, and subsequently encrusted with calcium carbonate. The crystal bundles which formed on or adhered to the filaments in A are identical to those pictured in Figure 7. C & D) Scanning electron micrographs of live, nonsterile, and dead, sterile cyanobacteria, respectively, which were inoculated with bacteria and placed in gelatinous media in the same petri dish (D is a close-up of B). The live filament pictured in C was removed after three weeks and a few crystal bundles can be seen on it. The dead, deflated filament pictured in D was removed after four days. Crystal bundles are not only adhering to the filament, they are forming under or within the outermost layer of it (arrow).

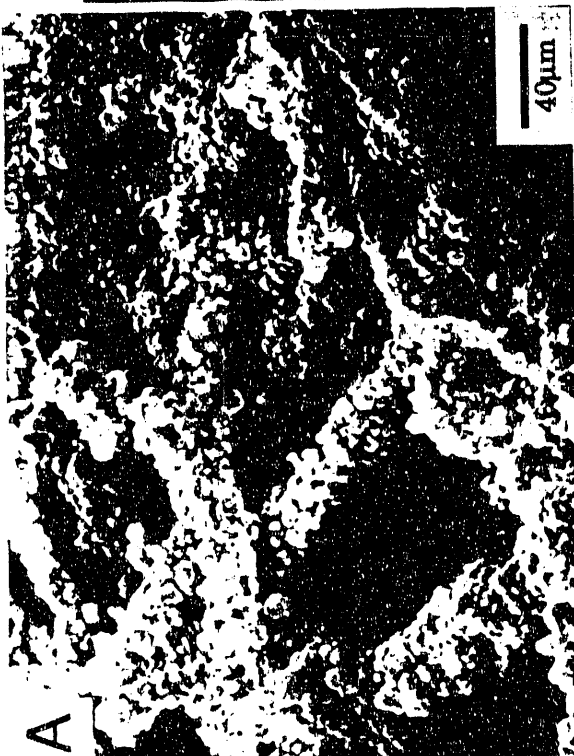

cyanobacteria, or the associated bacteria, in any control. In their experimental work in a natural environment, Kobluk and Risk (1977) found that only dead algal filaments were calcified, and similar observations have been made with natural samples of algal mats from Follet's Island, Texas (Figure 19). These findings are somewhat more complicated in natural settings because some algae may contain compounds which inhibit calcium carbonate nucleation and precipitation (Borowitzka, 1982a), and calcification may be species specific in some cases (Monty and Hardie, 1976; Krumbein and Potts, 1979; Penetecost and Bauld, 1988) though not all workers agree (Golubic, 1973). Bacteria are invariably found on the naturally occurring samples of live cyanobacteria like those used in these experiments (Whitton, 1973; Golubic, 1976a; Park, 1977) and no attempt was made to obtain a bacteria-free culture of cyanobacteria. Consequently, it was impossible to establish a control for any experiment which used live cyanobacteria as a food source.

In these experiments, precipitation of calcium carbonate on cyanobacteria occurred only in the presence of live bacteria. Precipitation began within a few hours or days on dead algae in broth or gelatinous media, respectively. Cyanobacterial filaments were completely encased in crystal bundles, and the bundles were actually cemented together to form a rigid crust (Figure 9A). Precipitates were never observed to have formed on live filaments in less than two weeks, and in many cases precipitation did not occur for months. From these observations, it can be inferred that bacterially induced precipitation and cementation in cyanobacterial mats

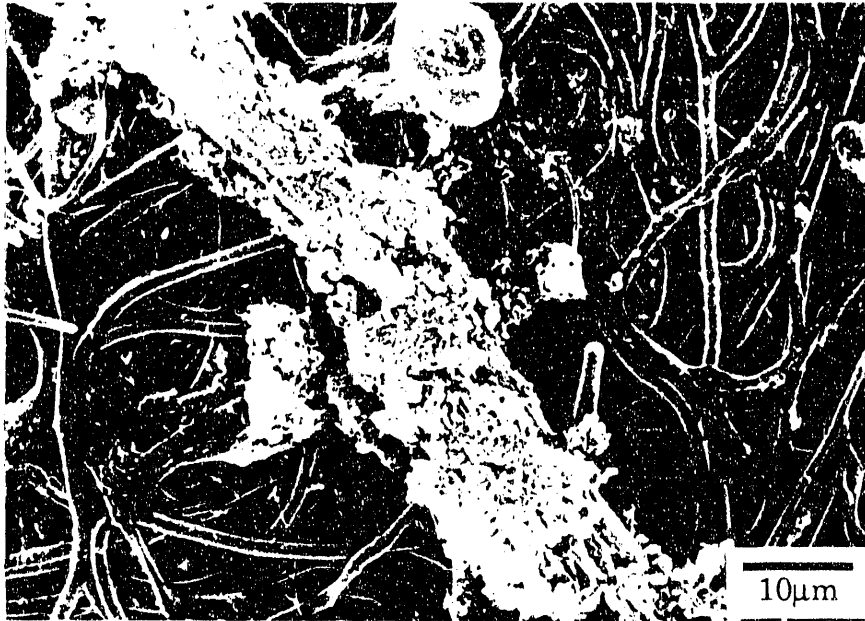

Figure 19. A scanning electron micrograph of a critically point dried sample of algal mat collected from Follets Island, Texas. The dead, deflated cyanobacterial filament was encrusted by calcium carbonate, and the live filaments on which it rests were not encrusted.

occurs primarily in the zone of decaying organic matter below the surface of the mat. Upward accretion of the mat would produce decaying, organic-rich zones which would approximately mimic the shape of the active surface of the mat. Cementation of these zones could lead to the formation of successive cemented laminations which would be recognized in the rock record as stromatolites.

GEOCHEMICAL DATA

Bacteria can concentrate certain elements within or on their cell walls as well as fractionate carbon and oxygen isotopes. Several authors (Carroll et al., 1965; Pautard, 1970; Bricker, 1971, p. 237; Takeichi and Okada, 1972; Beveridge and Murray, 1976; Morita, 1980) have demonstrated that live bacteria bind Ca, Mg, or other metals to the cell wall. Greenfield (1963) has demonstrated that as much Ca and Mg can be adsorbed by the cell walls of dead bacteria as live bacteria. The ability of some bacteria to fractionate oxygen and/or carbon isotopes has been recognized (Kaplan and Rittenberg, 1964; Cheney and Jensen, 1965; Behrens and Frishman, 1971; Friedman, 1975; Friedman and Sanders, 1978; Lein, 1978; Estep, 1982; Krumbein and Swart, 1983; Aizenshtat et al., 1984; Schidlowski et al., 1985). Unfortunately, because of the particular processes at work, bacterially induced precipitates of CaCO_3 can be either lighter or heavier with respect to carbon isotopes than an abiotic precipitate from the same environment (Krumbein and Swart, 1983). In any case, precipitates that

form due to bacterial influences should be geochemically different from abiotically induced precipitates found in the same environment.

Atomic Absorption Data

Presumably, if precipitation begins due to bacterial activity and proceeds abiotically, as suggested by Morita (1980) and Chafetz (1986), then smaller particles which are composed of a high percentage of bacterially induced precipitates should be geochemically different than larger particles from the same environment which are primarily abiotic overgrowths on bacterially induced precipitates. Thirty-six size sorted samples from five different lakes on San Salvador, Bahamas, were analyzed for Fe, Zn, Ca, Mg, Sr, Mn, Na, and K with an atomic absorption spectrophotometer to test this hypothesis. In addition, 31 of these 36 samples, and five laboratory precipitates were selected for isotopic analysis. A complete listing of geochemical data appears in the appendix.

Some elemental differences between grains less than 62 μ m and those greater than 62 μ m were apparent. Fe and Zn values for the less than 62 μ m size fraction were extremely elevated and Ca values were slightly depleted relative to larger size fractions. No other apparent differences exist (Figure 20).

Most size-sorted samples were treated with 30% H₂O₂, 5.25% NaOCl, or both to remove organic matter. A standard was prepared along with each set of samples and additional standards that had been treated with

Figure 20. Plots of grain size vs. elemental composition for recent sediment from San Salvador (see appendix for full data set). In each case the $<62\mu\text{m}$ category contains 6 data points; the $62\text{-}250\mu\text{m}$ category contains 2 points; the $250\text{-}590\mu\text{m}$ category contains 5 points; and the $>590\mu\text{m}$ category contains 19 points. Data for host rock and mollusc shells listed in the appendix are not included in these plots.

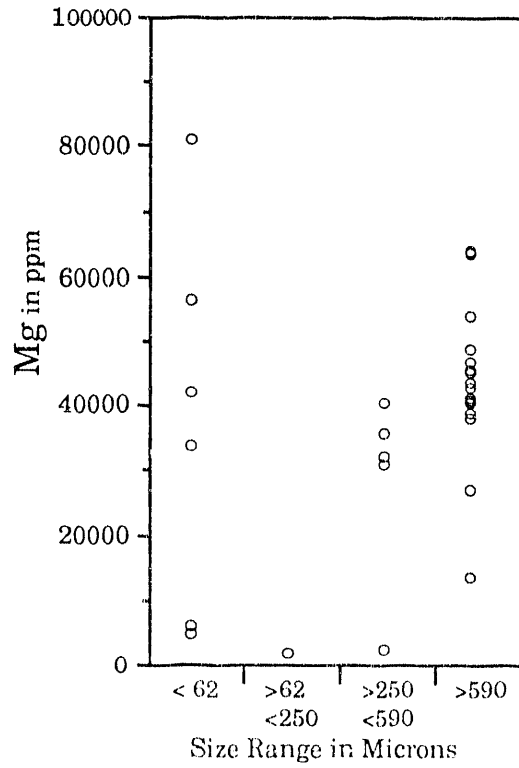
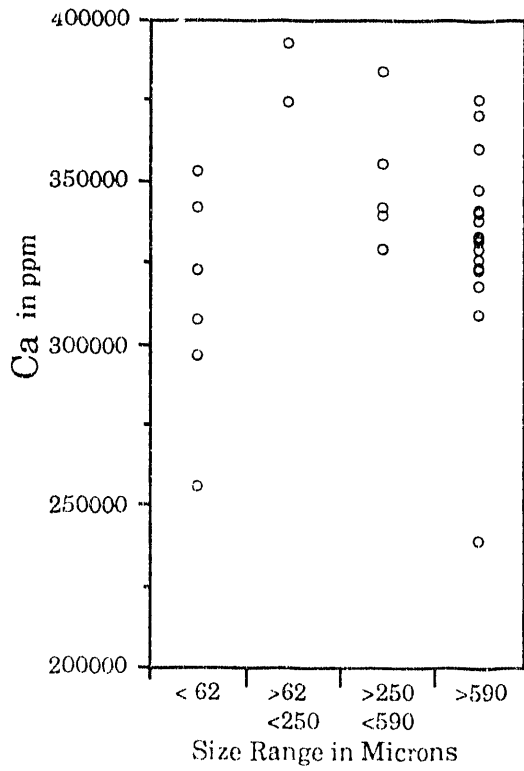
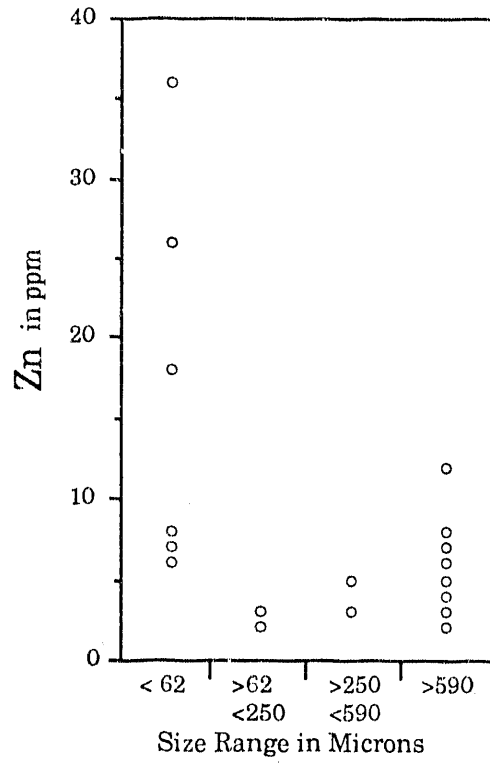
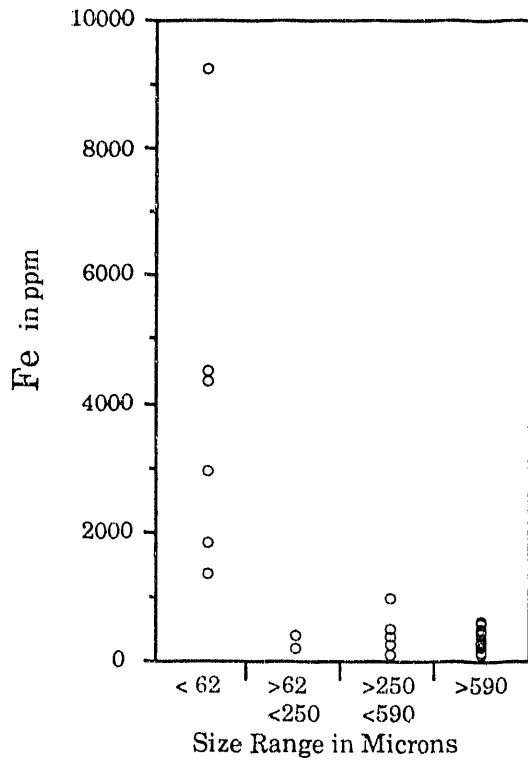

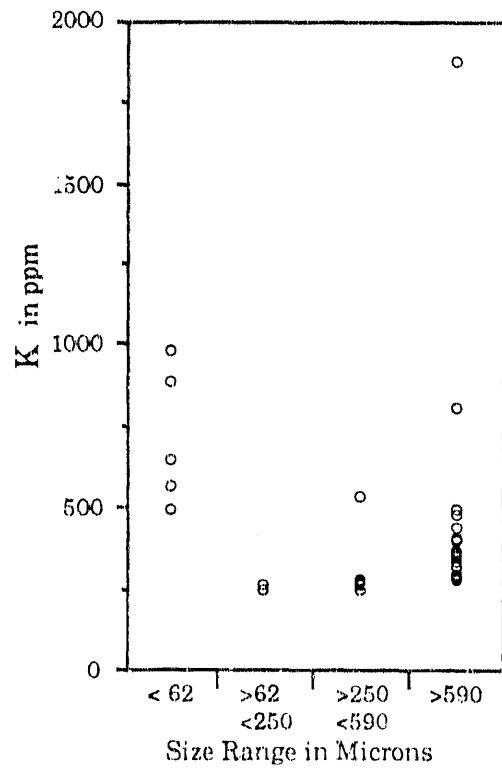
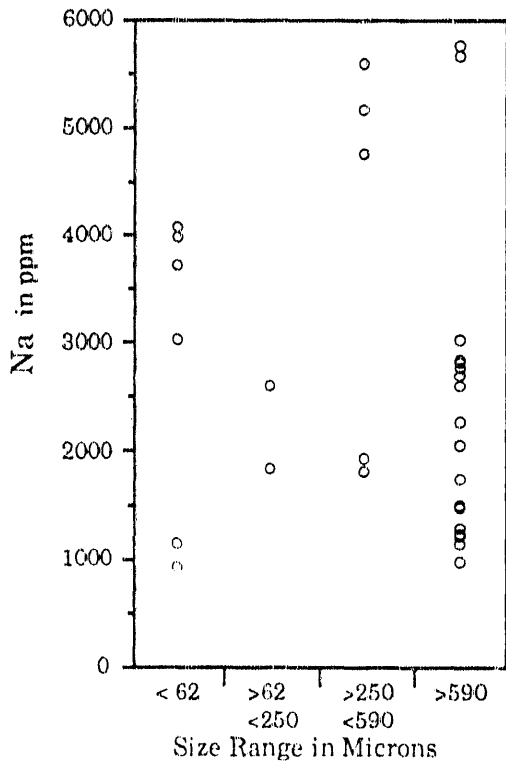
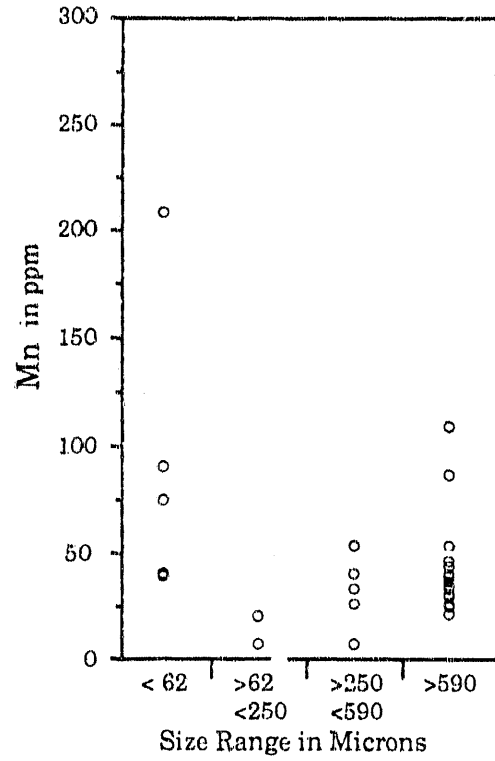
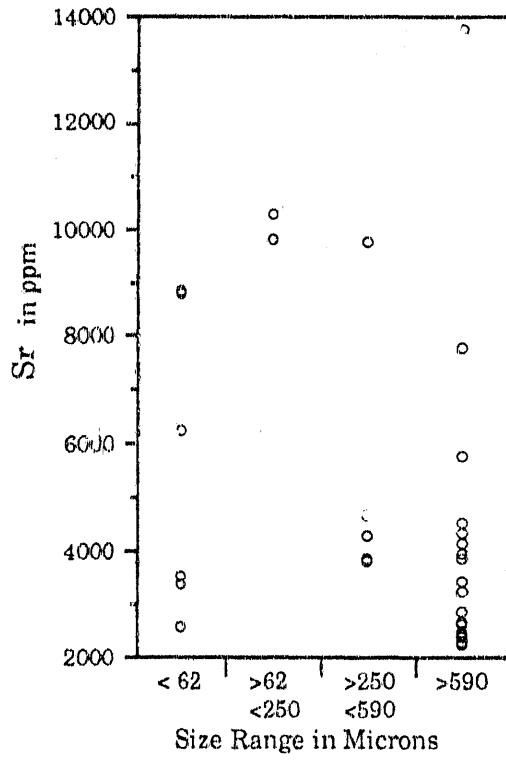

30% H_2O_2 and 5.25% NaOCl were used. These treatments do affect the results, sometimes significantly, however, several aspects of the procedure minimize the effects of these treatments. First, in cases where a single sample yielded more than one size fraction, all size fractions were separated after it had been treated, so all size fractions were treated uniformly. One might argue that the finer size fraction could adsorb more ions than larger size fractions because of the increased surface area to volume ratio, but the standard was also less than $62\mu m$ so it should be able to adsorb an equivalent concentration of ions. In the standards that had been treated with 30% H_2O_2 and 5.25% NaOCl there was a relative increase in Fe and Sr, and a decrease in Mn, Na, and Mg. K and Ca each displayed a relative decrease in the standard treated with 5.25% NaOCl and a relative increase in the standard treated with 30% H_2O_2 , and Zn displayed no change and a slight increase, respectively.

The relative changes induced by the treatment of samples from San Salvador, with H_2O_2 and NaOCl could have falsely enhanced the relative enrichment of Fe and Zn, and should have had little or no effect on the relative depletion of Ca within the finest size fraction samples. The standard treated with H_2O_2 displayed a 10% relative increase in Fe, and a 40% relative increase in Zn. The standard treated with NaOCl displayed a 61% relative increase in Fe, and no relative increase in Zn. The average value for Fe of the $<62\mu m$ size fraction is more than 307% larger than the single largest value for Fe in any other size fraction. The average value for Zn of the $<62\mu m$ size fraction is about 110% larger than the single largest

value for Zn (excluding values for host rock and mollusc shells) in any other size fraction.

It seems unlikely that the treatments to remove organic matter, alone, could induce the observed enrichment of Fe and Zn within these samples because similarly treated standards did not display such a large change. To do so, significant quantities of these elements would have to somehow be selectively leached from the larger size fractions and adsorbed onto the finest size fraction. This seems unlikely, however, the possibility cannot be ignored.

Carbon and Oxygen Isotopic Data

Carbon and oxygen isotopic data were not particularly useful in delineating samples based on particle size primarily because an insufficient number of analyses have been conducted on size-sorted samples to delineate any trends which might exist. The finest size fractions of most samples were obtained by treating large quantities of organic matter with 30% H_2O_2 . There could have been an exchange of some oxygen, altering isotopic ratios. The isotopic data, however, clearly demonstrate that the chemistry differs detectably from lake to lake (Figure 21). Even if the oxygen values have been altered by exchange with the H_2O_2 , the carbon values delineate the samples into groups which correspond to the lakes from which the samples were collected. The L1 and L7 samples are from the same lake (Figure 2C) which is connected to the ocean by

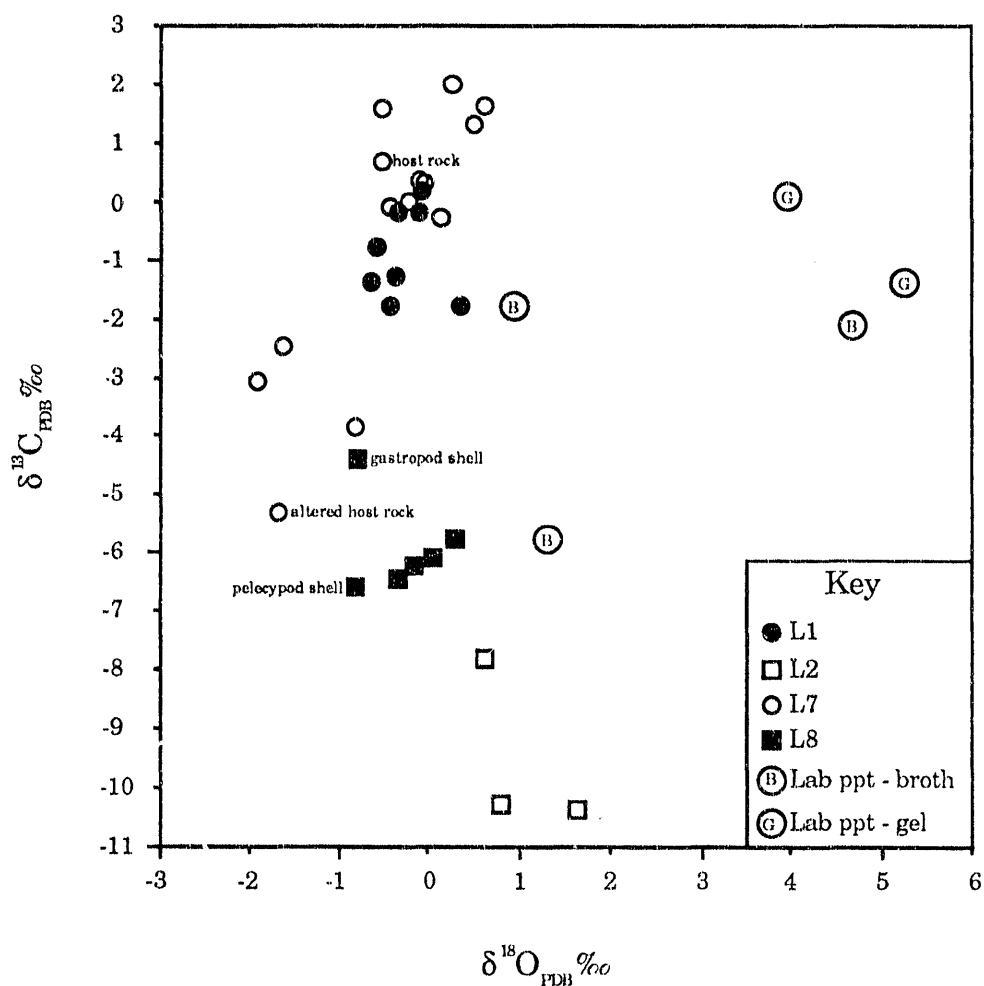

Figure 21. Plot of carbon and oxygen isotopic values for samples from San Salvador, Bahamas (see Figure 2C for sample locations), and laboratory precipitates formed from Baffin Bay bacteria in broth and gelatinous media. Samples of shell material and host rock are indicated where appropriate.

underground conduits. There is regular exchange between lake water and marine water due to tidal influences. These samples have heavier carbon values than the L2 samples and the L8 samples (Figure 2C), both of which appear to have little if any interaction with the marine realm. Consequently, the differences in carbon isotopic values are most likely related to both the composition of the water in the lakes, and the ability of the dominant biota living in each lake to fractionate carbon which are, in turn, related to evaporation and the interaction of the lakes with the marine environment.

With only five data points very little can be said of the laboratory precipitates with any certainty. Some tentative and admittedly tenuous conclusions may be drawn. The data points seem to fall into a different group than the naturally occurring samples. This is probably due to the initial composition of the growth medium. In addition, it is tempting to speculate that the material formed in gelatinous media might have had heavier carbon values because there was less circulation and less opportunity to preferentially incorporate heavier carbon into the growing organic material. Rodina (1972) has noted that oxygen diffusion through agar is relatively slow and it is probably reasonable to assume that carbon diffusion is also slow. Consequently, the growing bacteria had to metabolize all the carbon in their immediate vicinity, both the light and the heavy, because diffusion through the gel was too slow to allow bacterial fractionation. More experimentation in this direction would be worthwhile.

PRECIPITATION IN A SEDIMENT COLUMN

Several attempts were made during the course of this study to establish bacterial growth and induce precipitation of calcium carbonate within a sediment column. To date, these attempts have failed for one or more reasons. Initial attempts were made by simply introducing assorted carbonate and siliciclastic sediments into the bottom of a glass container, covering it with the growth medium, and inoculating the sterile experiment with bacteria. The bacteria invariably thrived in the liquid above the sediment and calcium carbonate precipitated in the liquid column and at the liquid/air interface, but not in the sediment, regardless of the sediment composition. Experiments were allowed to continue for approximately a month. Examination of the sediments under a microscope revealed a few very minute crystals which had either grown on, or clung to sediment grains but no substantial or unequivocal precipitation occurred in the sediment.

Some studies have shown that there is a strong relationship between the bacterial population in marine sediment and that, in general, the smaller the grain size, the more abundant the bacteria (ZoBell, 1938; Dale, 1974). It was speculated that the grain size of the sediments used (fine to medium sand-sized) might have been too coarse to establish and support sufficiently large numbers of bacteria. The sediments were pulverized in a mortar and pestle and the experiments were repeated with mud-sized carbonates and quartz. The results were the same, precipitation of calcium

carbonate in the liquid and at the liquid/air interface. The pulverized sediment was so fine that it could not be determined if any crystal growth had occurred in or on the sediment, but no large scale lithification or cementation was observed.

The experiments were modified to include layers of sterilized filamentous cyanobacteria as a food source within the pulverized sediment. Once again, the results were the same. No lithified horizons had formed and crystal growth in or on the sediment grains was undetectable.

It was speculated that the bacteria in the sediment rapidly metabolized the available nutrients and died, so one final attempt was made with Baffin Bay ooids in a specially constructed test tube that allowed the periodic flow of a nutrient-rich medium through the sediment column (Figure 3). The ooids were not pulverized as the flow of medium through the sediment column would be too slow. Approximately 0.5ml of 2216E broth prepared for anaerobes per 1.0cc of sediment was passed through the sediment column daily. Within two days the sediment column turned black and remained so until the experiment was discontinued some two months later. The bacteria had clearly thrived both in the liquid and in the sediment, however, precipitation of calcium carbonate only occurred in the liquid column and at the exit hole from the test tube. An examination of the ooids did not reveal either precipitation on them, or dissolution of them.

The formation of lithified horizons in the sediment column is important because that is where bacterial activity is extremely high and where they may act to produce (or dissolve) calcium carbonate in many

cases. The experiments noted above may have failed simply for lack of time.

DISCUSSION

Bacteria, as a group, can tolerate temperatures of 0-100°C, salinities of 0-300‰, and pH values of 4.5-10. They can maintain anaerobic conditions around themselves when placed in a stream of oxygenated water, and some laboratory cultures have lived at 104°C and 1000 atmospheres. They are found in ocean bottom sediments as well as thousands of meters down in oil well brines (ZoBell, 1963; Jorgensen and Revsbech, 1983; and others). Brock (1976, p. 147) has said: "As far as I know, low water potential is the only environmental factor which can completely inhibit microbial activity under natural conditions." May and Perkins (1979, p. 371) have said:

Bacteria are universally associated with all animals, plants, and organic detritus, and have been found active within bottom sediments at all water depths and to all sediment depths examined....

In many of the environments in which they are found, bacteria have the potential to induce the precipitation of calcium carbonate. It has been amply demonstrated since the early 1900's that bacteria do induce the precipitation of calcium carbonate under laboratory conditions and more recently, there has also been substantial evidence to indicate that they are doing so under natural conditions in the recent, and have done so in the geologic past as well. At this point it will be taken for granted that some portion of recent and ancient carbonate sedimentary deposits formed under

the influence of bacterial activity. The question, once again, is: "How can geologists distinguish bacterially induced precipitates from other types of biotic, or abiotic precipitates?"

RECOGNITION OF BACTERIALLY INDUCED PRECIPITATES IN RECENT SEDIMENTS

Based on the research conducted here and elsewhere, it becomes apparent that there are a variety of distinct forms of calcium carbonate crystals and crystal bundles which occur in association with bacterial activity, and that some of these forms appear to be unique to such environments. These bacterially induced crystals or crystal bundles (crystal aggregates) that formed in the laboratory occur as brushes, rods (also called sheaves or bundles), swollen rods, dumbbells, spheres (various forms and descriptions include: buttons, hemispheres, peloids, pellets, ooids, spherules, spherulites, spherulitic aggregates, etc.), discs, rhombohedra, tetragonal disphenoids, and tetragonal dipyramids. Of these forms, the calcite dumbbells, and crystal bundles which resemble rhombohedra, tetragonal disphenoids and tetragonal dipyramids, appear to be uniquely bacterial in origin, and they have all been observed in naturally occurring recent marine sediments in areas where bacteria are abundant. Brushes, swollen rods, discs and curved dumbbells appear to be uniquely bacterial in origin as well, however, these forms have not been reported by other laboratories nor, as yet, observed in natural settings (except the single

case of the swollen rods found within the mollusc spine as noted above). Spheres of various descriptions and aragonite dumbbells have also been produced by bacteria and frequently observed in natural environments, however, Oppenheimer (1961), Buck and Greenfield (1964), Puri and Collier (1967), and McCallum and Guhathakurta (1970) have reported the formation of dumbbells or bundles in uninoculated control flasks (although Oppenheimer, 1961, did report his control flask was contaminated with fungi, and Buck and Greenfield, 1964, reported "organic debris" within the dumbbells which might have influenced nucleation) and spherical forms appear to have a wide range of modes of formation from pellets to abiotic precipitates.

The presence in a sediment sample of any of the unique, bacterially derived crystals or crystal bundles listed above should suffice as proof of bacterial influences on the precipitation of the sediment. The actual extent of the role the bacteria played in creating the deposit may be qualitatively gauged by the relative proportion of crystals or crystal bundles present - presuming that they have not been selectively destroyed or rendered unrecognizable by diagenetic effects. It appears, in some examples, that almost 100% of the material coating algal filaments from Fresh Creek sink holes and Ginette Pond on Andros Island were precipitated due to bacterial activity in some cases.

RECOGNITION OF BACTERIALLY INDUCED PRECIPITATES
IN THE ROCK RECORD

Many workers have hinted that bacterially induced precipitates may be abundant in the rock record, but Friedman (1972b, p. 1082) makes one of the strongest statements:

The current thinking in carbonate petrography is that 95-98 percent of all limestones, including the fine-grained micritic limestones, were synthesized by shell-building organisms. According to the interpretation presented in this paper, many "typical basin limestones" may in fact have formed by [bacterially induced] replacement of sulphur.

In fresh samples of recent sediments destruction or obfuscation of crystal forms is less of a problem than it would be in ancient samples. In addition, more information about the depositional environment would probably be available and, therefore, a researcher would be alert to the potential bacterial contribution in forming the sediment. In ancient rock samples diagenesis may have altered or destroyed the finer crystals and crystal bundles. Even if they have survived, they are generally small enough so that they would be obscured by other grains when looking through a standard thin section. However, in many cases, the larger spherical forms commonly survive and numerous "pelleted" areas may be visible in thin section (Chafetz and Folk, 1984; Chafetz, 1986). Because spherical forms are not uniquely bacterial in origin, additional criteria must be used to establish a bacterial influence on their formation. Chafetz

(1986) has demonstrated that some marine peloids formed due to bacterial influences and he suggests that they may be recognized in several ways by examining the cloudy core of the peloidal grain. Some criteria are: (1) the presence of bacterial remains which are visible within etched samples in SEM, (2) the presence of numerous micropores of bacterial dimensions (or slightly larger as oxidation of bacterial remains creates an acidic environment and etches out the pore) which are due to decomposed remains, (3) a brown coloration in thin section due to included organic matter, and (4) the size of the peloid (Chafetz, 1986). Size is an important factor because when the bacterial clump becomes encased in cement, the bacteria die, and abiotic precipitation takes over. Most spherical bundles of crystals produced in the laboratory had diameters from 10-200 μm with cloudy, bacteria-rich cores of up to 65 μm . As noted by Chafetz (1986), most reports of peloids place them within the 20-60 μm range which does not span the size variation observed in modern-day fecal pellets or ooids. Larger spherical crystal bundles from these laboratory experiments invariably contained bacteria in the centers when they formed (Figure 6B) and the features described by Chafetz (1986) would very likely be produced if they were lithified. Based on the laboratory experiments conducted here and elsewhere, these are sound criteria for establishing bacterial influence on a precipitate.

The lack of the features described above does not preclude a bacterial origin as bacteria encased in carbonates can decay within 96 hours and may leave no physical trace in recent or ancient sediments (Krumbein et

al., 1977). In addition, the small pores that remain may be readily filled with cements during diagenesis (Chafetz and Folk, 1984). A complication arises because fecal pellets invariably contain numerous bacteria and may resemble bacterially induced precipitates, but there are two criteria other than size and bacterial content to delineate between spherical objects of bacterial or fecal origin. First, all of the precipitates grown in the experiments conducted here display either a radial structure which may or may not contain concentric laminations, or they are optically continuous. One would expect fecal pellets to be composed of randomly oriented crystalline material which reflects the characteristics of the sediment which was ingested. Second, all of the precipitates are solid, that is, they would fracture far more readily than they would deform whereas fecal pellets, unless cemented or lithified, deform readily. Again, there are complications because bacteria may be responsible for the cementation of fecal pellets, as well as grapestones and mud aggregates (Purdy, 1963).

The association of bacteria with spherical particles is by no means limited to marine peloids. Numerous workers have noted the presence of ooids, oncoids, peloids, spherulites, a "clotted texture" and other variously described spherical features within algal mats and associated deposits. Some workers attribute the genesis of these particles to algae (Aitken, 1967; Friedman et al., 1973; Golubic and Campbell, 1981), others attribute the genesis to bacteria (Krumbein and Cohen, 1974; Monty, 1981; Friedman et al., 1985) and some skirt the matter by citing "microbial" activity (Kennard and James, 1986). Golubic and Barghoorn (1977) have observed that some

cyanophytes can reproduce in a manner that produces spherical aggregates of algal cells. These could, conceivably, be calcified by bacteria to form spherical particles, and this might be a means of generating spherical particles in algal mats. Similar features have also been found in other types of deposits and linked to bacteria (Friedman et al., 1974; Chafetz and Meredith, 1983; Camoin and Maurin, 1988).

FACTORS THAT INFLUENCE PRECIPITATE MINERALOGY AND FORM

There are clearly many things which affect the mineral precipitated as well as the form of the mineral. Throughout these experiments the two most important factors were the medium viscosity, and the calcium source. The medium viscosity controlled, to some extent, the rate of ion diffusion through the medium and, consequently, the rate of precipitation. It is believed that the rate of precipitation controlled the mineral, either aragonite or calcite, which formed. Aragonite formed in liquid media where ionic mobility and precipitation rates were high, and calcite formed in the gelatinous media where ionic mobility was low and precipitation rates were slower. The form of the individual crystals which composed crystal bundles was related to the mineral precipitated. Aragonite bundles were composed of needle-like crystals and calcite bundles were composed of equant or flattened rhombohedral crystals, but in many cases the overall form of the crystal bundles was the same.

The form of the crystal bundles was most noticeably affected by the use of CaCl_2 as a calcium source in some fresh-water gelatinous media. The precipitates that formed in these media were similar regardless of whether Baffin Bay or Andros Island bacteria were used so the differences can be attributed to the composition of the media. These differences may have been due to the lack of other ions normally found in marine water as well as to the use of CaCl_2 as the calcium source. However, when CaCl_2 was used in broth media no significant differences from the other broth media precipitate forms were observed.

The magnesium content of the calcite precipitates from this study ranged from 0.0-17 mole% for the samples measured. Some researchers suggest a need for organic matter in the formation of HMC (high-magnesian calcite). Towe and Malone (1970) have noted that HMC does not form in the laboratory under normal conditions in the absence of organic matter, Friedman et al. (1974) have associated HMC precipitation with decaying organic matter, and Mucci (1987) states that variations in temperature cannot account for HMC cements formed in nature and suggests that bacteria and/or adsorbed organic matter may influence HMC precipitation. Further, some researchers suggest that organic matter and/or bacteria play a role in the precipitation of dolomite (Gebelein and Hoffman, 1971; Davies et al., 1975; Davies et al., 1977; Mansfield, 1980; Machel and Mountjoy, 1986; Mucci, 1987).

AREAS FOR ADDITIONAL RESEARCH

There are several areas that could be studied further to delineate bacterially induced precipitates from other types of abiotic, and active and passive biotic precipitates. Virtually all the work that has been done has been conducted in broth or on gels. Gels appear to provide an environment similar to that found in algal and bacterial mucilage, and the same types of crystal bundles form in the laboratory and in nature. However, in nature a substantial amount of cementation takes place in the sediment column and, to date, laboratory reports of lithification by calcium carbonate within a sediment column, which may have been bacterially induced, are rare (Davies et al., 1975, Davies et al., 1977). However, lithification in the sediment column has been observed in nature (Friedman et al., 1973; Krumbein and Cohen, 1974) and some authors (Cloud, 1972; Puri and Collier, 1967) feel that bacteria may have more of a role in cementing preexisting calcium carbonate particles than in inducing the precipitation of discrete particles. Features larger than crystal bundles, such as lithified horizons, are more likely to have survived diagenetic alteration and to be recognizable in the rock record. Without laboratory produced examples, it is difficult to know what a bacterially lithified horizon would look like in the recent, much less in the rock record after substantial diagenetic alteration. Even within the thin, fragile crusts formed in the laboratory, it is difficult to distinguish boundaries of crystal bundles; diagenesis would, in all likelihood, only make them less distinct. Consequently, more laboratory

work needs to be done with the formation of larger forms of bacterially induced precipitates which might be more enduring, such as those described by Meredith (1980), Folk and Chafetz (1980), and Chafetz and Folk (1984).

Other goals for further experimental research include use of only sea water and algae as sources for salts and nutrients, respectively. Some work has been conducted along these lines, however, more needs to be done.

Geochemical studies, depending on their nature, may be of some use in detecting bacterially induced precipitates of calcium carbonate. Anaerobic decay is not always complete (Golubic and Barghoorn, 1977) and organic remains preserved in the rock record may serve as biomarkers. These remains would demonstrate the previous presence of bacteria, although there may still be some question as to just when the bacteria were introduced into the system, and what influence they may have had on calcium carbonate precipitation. Taylor and Parks (1985) have delineated different populations of sulfate reducing bacteria in recent sediments and Boon et al. (1978) have found evidence of bacteria in 3000-7000 year old sediments by analyzing fatty acid biomarkers. McKirdy (1976) has speculated that the bacterial component of recent and ancient stromatolites may be recognizable by analyzing aliphatic hydrocarbons. However, Bubela et al. (1984) have cast some doubt on the reliability of fatty acids and hydrocarbons as biomarkers.

Assuming that the Fe, Zn, and Ca trends discussed above are real and that they actually reflect differences which are due to bacterial action

(admittedly, an assumption of questionable merit), care would have to be invoked in applying these results to other areas and to ancient samples for several reasons. The bacterial "component" of even micron-sized grains may be so small as to be completely overwhelmed by the abiotic component. Precipitation can clearly occur over a period of time, and conditions may change significantly (rainy season, drought, some lakes not tidally influenced by seawater, etc.) and these effects may obscure the geochemical signature of the bacterially induced component of the sediment. Geochemical data have the potential to indicate the presence of bacterially induced precipitates of calcium carbonate within recent sediment samples based on differences in crystal size. With this information, the relative proportion of bacterially influenced components, could be estimated. However, this type of data could not be obtained if the sample could not be size segregated. Unfortunately, this excludes most examples from the rock record. Additionally, diagenetic alteration would probably homogenize the sample even if the diagenetic front were only a few microns wide.

Many of these parameters can be controlled for in studies of recent sediments, but it is often virtually impossible to determine the original trace element composition of an ancient environment. Without a basis for comparison, trace element data are almost meaningless. Also, the actual portion of a precipitate that is bacterially influenced may be volumetrically small if abiotic precipitation takes over after crystals nucleate around bacteria. A researcher would be left with an almost inseparable mix of bacterially and abiotically induced precipitates. This research was

undertaken to develop criteria by which bacterially induced precipitates of calcium carbonate could be recognized in recent sediments and the rock record. Regrettably, geochemical investigations into elemental compositions of the bacterially induced precipitates were deemed generally unsuitable to that end.

Analysis of isotopic ratios, particularly carbon, may indicate the influence of bacteria on a precipitate. However, fractionation may have been algal mediated initially, or subsequently by bacterial decomposition of plant material containing photosynthetically fractionated carbon. So in many cases it would be difficult to attribute the resultant precipitate solely to bacterial activity based on its isotopic composition. With further study, isotopic ratios may be of value, at the very least, to alert researchers to the former presence of bacteria, and allow them to look for other indications that bacteria may have had a role forming the deposit.

SUMMARY AND CONCLUSIONS

Bacteria passively induce the precipitation of calcium carbonate under a variety of laboratory and natural conditions. Experiments to induce the precipitation of calcium carbonate were conducted with live aerobic and facultative bacteria found in association with cyanobacterial mats from Baffin Bay, Texas, and Andros Island, Bahamas. A variety of controls insured that bacterial strains were not contaminated during collection, and that the laboratory precipitates that formed in almost all of the more than 120 experiments did so in response to bacterial activity. Nutrients, medium viscosities, light, temperature, salinity, aeration, and other conditions were varied between, but generally not within, experiments.

The precipitates which formed can be fitted into a hierarchy based on the size of the feature observed. Crusts, which are composed of bundles of crystals, form at the air/liquid interface. They are generally less than 0.5mm thick and are as laterally extensive as the container in which they form. As such, they are the largest observed feature in bacterially induced precipitates. Bundles with 5-200 μ m diameters are formed from numerous individual crystals. Needle-like crystals of aragonite may be 0.05 μ m in diameter and 4 μ m long, and individual calcite rhombohedra may be up to about 2 μ m long. These crystals are invariably seen as part of a crystal bundle. The crystal bundles and individual crystals are the second and third largest features of bacterially induced precipitates, respectively. The

smallest observed features are 0.1-0.4 μ m spheres and rods of which some individual crystals and crystal bundles are composed.

The vast majority of reported laboratory precipitates occur as bundles of individual crystals which form rods, dumbbells, and spheres, as well as modified forms of these general shapes. Individual aragonite needles have also been reported from some experiments. All of these forms of crystal bundles were produced during the course of this research, however, no needles that were not part of a crystal bundle were observed. In addition to these forms, crystal bundles resembling discs, rhombohedra, tetragonal disphenoids, tetragonal dipyramids, and optically continuous crystals resembling brushes formed. Crystal bundles which resemble rhombohedra, tetragonal disphenoids, tetragonal dipyramids, and calcite dumbbells appear to be uniquely bacterial in origin and they have all been observed in naturally occurring recent marine or near shore sediments in areas where bacteria are abundant. Brushes, swollen rods, discs and curved dumbbells also appear to be uniquely bacterial in origin. However, these forms have not yet been described from natural or laboratory precipitates of either a biotic, or an abiotic origin (except the single case of the swollen rods found within the mollusc spine as noted above). A wide variety of spheres and aragonite dumbbells have also been produced by bacteria. These two forms have been observed frequently in natural environments, however, they also have modes of formation which are apparently unrelated to bacteria. Consequently, these two forms may not be

used as the sole criterion when determining if bacteria played a role in sediment precipitation.

Abiotic precipitation occurred in some control (uninoculated) experiments due to desiccation of the gel. In one case a control experiment was contaminated by mould and bacteria, and calcium carbonate formed. These examples are significantly different from purely bacterially induced precipitates in several respects such that they may be distinguished from the bacterially induced precipitates.

Nutrients, light, temperature, salinity, and aeration do not seem to significantly affect the form or mineralogy of the precipitate. Differences in bacterial composition sometimes creates slight variations in the forms noted above, and the brushes were only produced with bacteria from Baffin Bay ooids. The use of CaCl_2 as the calcium source in gelatinous media produced crusts and discs which had not been observed in the other gelatinous or broth media. The viscosity of the medium appears to be the overriding control on whether calcite or aragonite is precipitated, regardless of other conditions. In broth media ionic mobility is high, crystal growth can proceed rapidly, and aragonite is precipitated. In gelatinous media, ionic mobility is lower, crystal growth proceeds more slowly, and calcite precipitates. All else being equal, precipitation invariably proceeded more rapidly in broth media than in gelatinous media. The same phenomenon is observed in some natural environments.

Bacteria and/or organic debris have been implicated in the formation of HMC and dolomite in other studies. In at least one case, a bacterial

culture induced the precipitation of a substance relatively rich in Mg, which was very resistant to acid etching. A bulk XRD analysis indicated that 17 mole % Mg calcite was present in the sample and it is possible that the grain in Figure 17 contained a higher (or lower) percentage of Mg (based on qualitative EDAX measurements). The resistant bands in this grain may have been dolomite. Such grains were extremely rare in the precipitate and if they did contain dolomite it may well have been present in quantities too small to show up in an XRD analysis. However, no firm proof of dolomite formation exists except for the extreme resistance of the layers, and their relatively enriched Mg composition.

It was found that precipitation of calcium carbonate on cyanobacteria (blue-green algae) occurred preferentially on dead cyanobacteria in the presence of bacteria. Live cyanobacteria were also encrusted, but much more slowly, and no precipitate formed on dead, sterilized cyanobacteria in the absence of live bacteria. Consequently, lithification of algal mats to form stromatolites may take place below the active mat surface in the zone of decaying organic matter due to bacterial activity.

Interpreting trace element and stable isotopic data of precipitates, with respect to bacterial influences, depends in large part on knowing the prevailing conditions at the time of formation of the precipitate. This type of information is of progressively less use as those conditions become less certain. Exceptions occur when the effect of the bacteria is quite substantial, as it is, for example, with methane formation. Thus, geochemical data are of more use for recent sediments. Perhaps when

recent environments are better understood with respect to bacterial activity, geochemical data will be of more value in the rock record.

Attempts to produce bacterially induced precipitates within a column of sediment have failed in the experiments conducted. Additional work in this direction is imperative because bacteria are particularly abundant and active in the sediment and, consequently, this is an area where bacterially induced precipitation may be most significant. In addition, larger scale features, such as lithified crusts, which may form in the sediment column are more likely to survive diagenetic alterations and serve to distinguish the bacterial origin of the precipitate.

The presence of brushes or crystal bundles which resemble rhombohedra, tetragonal disphenoids, tetragonal dipyrramids, calcite dumbbells, swollen rods, discs and curved dumbbells in recent sediments should be sufficient criteria to demonstrate a bacterial influence. However, most of these forms apparently do not survive diagenetic alteration and they may be of little use in the rock record. If they do survive, many would be considerably thinner than the standard thin section and would be obscured by other grains. Some of the larger spherical forms, such as "peloids" (Chafetz, 1986) and "bacterial clumps" (Folk and Chafetz, 1984), do survive and they may be recognized by the inclusion of bacterial remains or bacteria-sized voids in the core of the grain, their average size ranges of 10-60 μ m, and the cloudy, organic-rich core of the grain (Folk and Chafetz, 1984; Chafetz, 1986).

To conclude, bacteria are out there right now, 24 hours a day, inducing calcium carbonate precipitation, and they have been doing so for millions of millennia. It remains for interested geologists to learn how to recognize these precipitates, and ferret them out of hiding.

APPENDIX

This appendix contains brief descriptions of samples and sample treatments as well as values for trace element, and carbon and oxygen isotopic analyses. Sample designations which begin with "L" refer to samples from San Salvador, Bahamas, and they may be located on the map in figure 2C. Some samples were selectively picked free of shell material, ostracode carapaces, etc. (designated as "no shells") before analysis and others were run as bulk samples (designated as "bulk") to see if there were any significant differences between the two. Lithified or semilithified crusts are designated as "crust". Standards for AA analyses were an internal U of H standard. A standard of 1/2 the normal weight was tested to see if using less sample was reasonable. Standards treated in 30% H₂O₂ and 4.5% NaOCl were also run to determine how these treatments affected the results. Five laboratory precipitates formed by Baffin Bay bacteria in both broth and gelatinous media were also analyzed for isotopic composition. UH2 was used as the standard for carbon and oxygen isotope analyses. Values for oxygen are given in PDB and SMOW, values for carbon are given in PDB. Standard deviations listed for all data reflect only machine precision.

Sample Label	Description (if not granular)	Treatment		Size in Microns
		H ₂ O ₂	NaOCl	
1	L1-b			>590
2	L1-d			>590
3	L1-d			>590
4	L1-g	X	X	<62
5	L1-g	X	X	>250 <590
6	L1-g	X	X	>250 <590
7	L1-g	X	X	>590
8	L1-g	X	X	>590
9	L2-a	X	X	<62
10	L2-c	X	X	<62
11	L2-c	X	X	>62 <250
12	L2-c	X	X	>250 <590
13	L2-c	X	X	>62 <250
14	L3-a	X	X	<62
15	L4-b	X	X	<62
16	L7-a	X		>590
17	L7-b			>590
18	L7-d1			>590
19	L7-d2			>590
20	L7-d3			>590
21	L7-d3			>590
22	L7-d3			>590
23	L7-d3			>590
24	L7-d			>590
25	L7-f		X	>590
26	L7-1f			>590
27	L7-2f			>590
28	L7-g			>590
29	L7-1g			>590
30	L8-b	X	X	<62
31	L8-b	X	X	>250 <590
32	L8-b	X	X	>250 <590
33	L8-b	X	X	>590
34	L8-b	X	X	>590
35	L8-b	X	X	>590
36	L8-b	X	X	>590
	Lab ppt. BB7A broth		X	
	Lab ppt. BB7B broth		X	
	Lab ppt. BB7A broth		X	
	Lab ppt. BB7A gel		X	
	Lab ppt. BB7A gel		X	

Sample Label	Fe	SDV	Zn	SDV	Ca	SDV	Mg	SDV
1 L1-b	435	11	7	6	310039	3993	64004	466
2 L1-d	633	6	4	1	347848	7658	38138	305
3 L1-d	473	9	5	1	338717	5584	26996	346
4 L1-g	1833	30	7	4	322602	4796	80946	460
5 L1-g	989	24	5	4	339572	6150	35695	328
6 L1-g	533	12	3	2	355398	5270	30848	199
7 L1-g	595	19	6	4	330026	2646	40344	185
8 L1-g	361	16	2	1	371139	6708	39044	222
9 L2-a	4490	29	36	3	341598	3306	6129	62
10 L2-c	2935	33	26	3	353254	3121	4914	53
11 L2-c	200	6	3	2	393214	5389	1730	47
12 L2-c	388	32	2	3	374507	3942	1708	59
13 L2-c	126	15	3	3	383852	3441	2383	73
14 L3-a	4332	41	18	3	255593	4407	42034	129
15 L4-b	9237	20	8	3	307633	2467	33847	3238
16 L7-a	371	12	6	3	360769	7294	41350	350
17 L7-b	453	36	8	4	324008	2950	63683	682
18 L7-d1	351	7	6	2	332655	3815	53917	326
19 L7-d2	162	14	5	3	332354	7587	45570	377
20 L7-d3	520	8	8	2	375820	3515	13355	122
21 L7-d3	272	10	12	3	239666	2311	48818	355
22 L7-d3	498	8	9	3	330514	4936	14096	224
23 L7-d3	1273	23	10	3	300644	8202	38723	516
24 L7-d	271	9	5	2	326611	3886	46778	364
25 L7-f	106	15	5	1	318444	6628	43468	192
26 L7-1f	299	14	4	3	338627	4017	40822	313
27 L7-2f	152	17	4	2	332700	4848	45200	684
28 L7-g	130	7	8	1	341205	5108	38699	120
29 L7-1g	339	5	5	4	333500	7777	42722	444
30 L8-b	1368	21	6	4	296475	6565	56323	346
31 L8-b	402	19	3	3	328868	3349	40589	295
32 L8-b	288	8	3	6	341594	6899	32150	234
33 L8-b	308	13	3	2	323279	4197	41377	525
34 L8-b	235	14	6	3	342118	9976	40894	282
35 L8-b	598	22	6	2	391248	6435	1287	39
36 L8-b	113	12	12	2	394028	11845	4161	29
Standard	525	9	5	4	386303	3856	8045	86
Std 1/2 wt.	508	18	5	2	369652	2273	7821	87
Std. & NaOCl	847	19	5	4	383852	3309	7611	113
Std. & H ₂ O ₂	558	23	7	7	387193	6106	7744	141

Sample Label	Sr	SDV	Mn	SDV	Na	SDV	K	SDV
=====	=====	====	====	====	=====	====	====	====
1 L1-b	2657	75	87	1	2829	222	442	9
2 L1-d	7808	100	34	2	5756	200	402	8
3 L1-d	13752	201	22	6	5676	291	366	10
4 L1-g	3377	89	39	8	3022	85	493	11
5 L1-g	4298	78	33	3	1939	74	537	19
6 L1-g	4685	100	26	5	5591	90	280	8
7 L1-g	4332	101	33	5	2050	53	495	12
8 L1-g	3943	15	40	3	2606	212	355	8
9 L2-a	8774	132	41	6	3719	90	565	10
10 L2-c	8845	100	40	7	3984	120	564	8
11 L2-c	10286	109	7	6	2595	53	244	13
12 L2-c	9803	113	20	5	1840	526	263	8
13 L2-c	9742	109	7	4	4765	119	269	13
14 L3-a	6237	49	75	4	1153	61	888	11
15 L4-b	3547	39	208	8	925	170	978	23
16 L7-a	2484	32	26	1	1281	113	287	8
17 L7-b	2360	26	110	3	2798	107	1884	16
18 L7-d1	3856	57	44	2	1475	66	478	8
19 L7-d2	2854	27	35	4	979	259	364	3
20 L7-d3	3421	66	37	4	1218	305	291	7
21 L7-d3	3262	45	46	2	3014	89	801	9
22 L7-d3	3430	70	47	6	16252	141	799	17
23 L7-d3	1219	25	147	3	4218	217	308	18
24 L7-d	4545	27	39	2	1131	128	403	9
25 L7-f	2286	33	25	2	1729	77	282	11
26 L7-1f	2424	26	31	5	1495	131	335	5
27 L7-2f	2243	28	30	3	2757	105	364	6
28 L7-g	2631	74	34	2	2699	130	349	2
29 L7-1g	2403	29	34	3	1246	90	362	2
30 L8-b	2550	44	90	6	4077	41	646	20
31 L8-b	3798	40	54	9	1808	74	263	11
32 L8-b	3851	59	40	3	5157	54	246	12
33 L8-b	4170	43	46	7	1508	72	319	9
34 L8-b	5798	81	53	3	2259	127	289	10
35 L8-b	2394	15	6	6	2252	97	379	13
36 L8-b	2589	35	19	5	2643	78	238	11
Standard	499	15	525	9	798	40	152	5
Std 1/2 wt.	488	14	521	9	201	40	261	13
Std & NaOCl	529	17	490	12	0	53	118	12
Std & H ₂ O ₂	536	11	484	7	596	60	196	8

Sample Label	C ¹³ /C ¹²	SDV	O ¹⁸ /O ¹⁶	SDV	SMOW
=====	=====	=====	=====	=====	=====
1 L1-b	-0.198	0.035	-0.350	0.022	30.508
2 L1-d	0.180	0.035	-0.081	0.059	30.785
3 L1-d	-0.181	0.037	-0.086	0.024	30.780
4 L1-g	-1.806	0.022	0.350	0.028	31.231
5 L1-g	-1.383	0.043	-0.651	0.054	30.198
6 L1-g	-1.803	0.036	-0.441	0.031	30.415
7 L1-g	-1.276	0.034	-0.361	0.066	30.496
8 L1-g	-0.781	0.030	-0.578	0.031	30.274
9 L2-a					
10 L2-c					
11 L2-c	-10.256	0.035	0.812	0.045	31.707
12 L2-c	-10.380	0.057	1.648	0.023	32.569
13 L2-c	-7.800	0.043	0.606	0.052	31.495
14 L3-a					
15 L4-b					
16 L7-a	1.320	0.025	0.510	0.031	31.395
17 L7-b	-3.845	0.019	-0.818	0.049	30.026
18 L7-d1	-0.003	0.035	-0.234	0.041	30.628
19 L7-d2	0.670	0.027	-0.508	0.021	30.346
20 L7-d3	-3.087	0.016	-1.938	0.028	28.871
21 L7-d3	-2.460	0.038	-1.610	0.040	29.200
22 L7-d3	1.590	0.028	-0.528	0.031	30.316
23 L7-d3	-5.310	0.042	-1.670	0.042	29.138
24 L7-d	-0.110	0.060	-0.416	0.038	30.440
25 L7-f	1.991	0.037	0.248	0.060	31.126
26 L7-1f	0.329	0.073	-0.033	0.035	30.835
27 L7-2f	1.620	0.022	0.631	0.049	31.521
28 L7-g	-0.264	0.007	0.139	0.029	31.013
29 L7-1g	0.343	0.027	-0.105	0.041	30.761
30 L8-b					
31 L8-b	-6.201	0.028	-0.159	0.041	30.705
32 L8-b	-6.428	0.036	-0.351	0.043	30.507
33 L8-b	-6.089	0.054	0.038	0.045	30.909
34 L8-b	-5.748	0.030	0.303	0.050	31.182
35 L8-b	-6.555	0.046	-0.826	0.041	30.017
36 L8-b	-4.401	0.032	-0.776	0.047	30.069
Lab ppt. BB7A broth	-1.782	0.053	0.956	0.121	31.885
Lab ppt. BB7B broth	-5.754	0.045	1.312	0.097	32.223
Lab ppt. BB7A broth	-2.105	0.067	4.696	0.064	35.711
Lab ppt. BB7A gel	0.083	0.075	3.966	0.082	34.958
Lab ppt. BB7A gel	-1.371	0.046	5.267	0.018	36.299

Sample Label	C ¹³ /C ¹²	SDV	O ¹⁸ /O ¹⁶	SDV	SMOW
=====	=====	=====	=====	=====	=====
UH2 standard	0.648	0.025	-4.221	0.037	26.518
UH2 standard	0.560	0.038	-4.353	0.045	26.381
UH2 standard	0.525	0.025	-4.539	0.034	26.190
UH2 standard	0.618	0.028	-4.460	0.044	26.271
UH2 standard	0.614	0.089	-4.393	0.049	26.341

REFERENCES CITED

- Adams, R. W., 1983, General guide to the geological features of San Salvador: *in* Gerace, D. T., ed., Field Guide to the Geology of San Salvador, Third Edition: U. S. A., College Center of the Finger Lakes Bahamian Field Station, p. 1-66.
- Adolphe, J. P., and Billy, C., 1974, Biosynthese de calcite par une association bacterienne aerobie: Comptes Rendus de l'Academie des Sciences, v. 278, Serie D, p. 2873-2875.
- Aguilar, J., Ramos-Cormenzana, A., and Ruiz-Berraquero, F., 1978, Contribution to the study of crystal formation processes by bacteria: Proceedings of the Fifth International Working Meeting on Soil: Micromorphology, Granada, v. 1, p. 139-163.
- Aitken, J. D., 1967, Classification and environmental significance of cryptalgal limestones and dolomites, with illustrations from the Cambrian and Ordovician of southwestern Alberta: Journal of Sedimentary Petrology, v. 37, p. 1163-1178.
- Aizenshtat, Z., Lipiner, G., and Cohen, Y., 1984, Biogeochemistry of carbon and sulfur cycle in the microbial mats of the Solar Lake (Sinai): *in* Cohen, Y., Castenholtz, R. W., and Halvorson, H. O., eds., Microbial Mats: Stromatolites: New York, Alan R. Liss, Inc., p. 281-312.
- Andrews, J. E., 1988, Methane-related Mg-calcite cements in recent tidal flat sediments from the Firth of Forth: Scottish Journal of Geology, v. 24, p. 233-244.
- Ashirov, K. B., and Sazonova, I. V., 1962, On the mechanism of Biogenic sealing of oil accumulations confined to carbonate collectors: Mikrobiologie, v. 31, p. 680-683.
- Barghoorn, E. S., and Schopf, J. W., 1966, Microorganisms three billion years old from the Precambrian of South Africa: Science, v. 152, p. 758-763.
- Barghoorn, E. S., and Tyler, S. A., 1965, Microorganisms from the Gunflint Chert: Science, v. 147, p. 563-577.

- Bartels, H. A., 1951, Bacterial growth and crystal formation. II Production of calcium carbonate crystals: *Journal of Dental Research*, v. 30, p. 642-644.
- Bathurst, R. G. C., 1975, *Carbonate Sediments and their Diagenesis*, Second Edition: Amsterdam, Elsevier, 658p.
- Bauld, J., 1981, Geobiological role of cyanobacterial mats in sedimentary environments: Production and preservation of organic matter: *BMR Journal of Australian Geology and Geophysics*, v. 6, p. 307-317.
- Bavendamm, W., 1931, The possible role of micro-organisms in the precipitation of calcium carbonate in tropical seas: *Science*, v. 73, p. 597-598.
- Bavendamm, W., 1932, Die mikrobiologische Kalkfallung in der tropischen See: *Archiv fur Mikrobiologie*, v. 3, p. 205-276.
- Behrens, E. W., and Frishman, S. A., 1971, Stable carbon isotopes in blue-green algal mats: *Journal of Geology*, v. 79, p. 94-100.
- Bending, L., and Folk, R. L., 1987, Scanning electron micrograph from a University of Texas M. A. thesis (1985) by V. J. Pursell: *Journal of Geological Education*, v. 35, cover photograph.
- Berge, J. W., 1972, Physical and chemical factors in the formation of marine apatite: *Economic Geology*, v. 67, p. 824-827.
- Berkeley, C., 1919, A study of marine bacteria, Straits of Georgia, B. C.: *Proceedings and Transactions of the Royal Society of Canada*, Ottawa, Section 5, v. 13, p. 15-43.
- Bernauer, F., 1929, "Gedrillte Kristalle": *Borntrager*, Berlin from: *Forschungen zur Kristallkunde*, Heft 2. (from Keller, 1958)
- Berner, R. A., 1968, Calcium carbonate concretions formed by decomposition of organic matter: *Science*, v. 159, p. 195-197.
- Berner, R. A., 1969, Chemical changes affecting dissolved calcium during the bacterial decomposition of fish and clams in sea water: *Marine Geology*, v. 7, p. 253-274.

- Berner, R. A., 1971, Bacterial processes effecting the precipitation of calcium carbonate in sediments: *in* Bricker, O. P., ed., Carbonate Cements: Baltimore, Johns Hopkins Press, p. 247-251.
- Berner, R. A., 1975, The role of magnesium in the crystal growth of calcite and aragonite from sea water: *Geochimica et Cosmochimica Acta*, v. 39, p. 489-504.
- Beveridge, T. J., Meloche, J. D., Fyfe, W. S., and Murray, R. G. E., 1983, Diagenesis of metals chemically complexed to bacteria: Laboratory formation of metal phosphates, sulfides, and organic condensates in artificial sediments: *Applied and Environmental Microbiology*, v. 45, p. 1094-1108.
- Beveridge, T. J., and Murray, R. G. E., 1976, Uptake and retention of metals by cell walls of *Bacillus subtilis*: *Journal of Bacteriology*, v. 127, p. 1502-1518.
- Billy, C., 1975, Isolement des constituants d'une association bacterienne productrice de calcite: *Comptes Rendus de l'Academie des Sciences*, v. 281, Serie D, p. 621-623.
- Black, M., 1933a, The algal sediments of Andros Island, Bahamas: *Philosophical Transactions of the Royal Society of London, Series B*, v. 222, p. 165-192.
- Black, M., 1933b, The precipitation of calcium carbonate on the Great Bahamas Bank: *Geological Magazine*, v. 70, p. 455-466.
- Blakemore, R. P., Short, K. A., Bazylnski, D. A., Rosenblatt, C., and Frankel, R. B., 1985, Microaerobic conditions are required for magnetite formation within *Aquaspirillum magnetotacticum*: *Geomicrobiology Journal*, v. 4, p. 53-71.
- Boon, J. J., Liefkens, W., Rijpstra, W. I. C., Baas, M., and De Leeuw, J. W., 1978, Fatty acids of *Desulfovibrio desulfuricans* as marker molecules in sedimentary environments: *in* Krumbein, W. E., ed., *Environmental Biogeochemistry and Geomicrobiology Volume 1: The Aquatic Environment*: Ann Arbor, Ann Arbor Science Publishers Inc., p. 355-372.
- Boquet, E., Boronat, A., and Ramos-Cormenzana, A., 1973, Production of calcite (calcium carbonate) crystals by soil bacteria is a general phenomenon: *Nature*, v. 246, p. 527-529.

- Borowitzka, M. A., 1982a, Mechanisms in algal calcification: *in* Round, F. E., and Chapman, D. J., eds., *Progress in Phycological Research*, Volume 1: New York, Elsevier Biomedical Press, p. 137-177.
- Borowitzka, M. A., 1982b, Morphological and cytological aspects of algal calcification: *International Review of Cytology*, v. 74, p. 127-162.
- Braithwaite, C. J. R., Casanova, J., Frevert, T., and Whitton, B. A., 1989, Recent stromatolites in landlocked pools on Aldabra, western Indian Ocean: *Palaeogeography, Palaeoclimatology, Palaeoecology*, v. 69, p. 145-165.
- Bricker, O. P., 1971, *Carbonate Cements*: Baltimore, Johns Hopkins Press, 376p.
- Brightman, G. F., 1938, The Tom Sauk limestone member of the Bonnetterre Formation in Missouri: *Journal of Geology*, v. 46, p. 248-267.
- Brock, T. D., 1976, Environmental microbiology of living stromatolites: *in* Walter, M. R., ed., *Stromatolites: Developments in Sedimentology 20*: Amsterdam, Elsevier, p. 141-148.
- Bronner, F., and Freund, T. S., 1972, Calcium accumulation during sporulation of *Bacillus megaterium*: *in* Halvorson, H. O., Hanson, R., and Campbell, L. L., eds., *Spores V*: Washington, D. C., American Society for Microbiology, p. 187-190.
- Bronner, F., Nash, W. C., and Bolub, E. E., 1975, Calcium transport in *Bacillus megaterium*: *in* Gerhardt, P., Costilow, R. N., and Sadoff, H. L., eds., *Spores VI*: Washington, D. C., American Society for Microbiology, p. 356-361.
- Bubela, B., 1985, Effect of biological activity on the movement of fluids through porous rocks and sediments and its application to enhanced oil recovery: *Geomicrobiology Journal*, v. 4, p. 313-327.
- Bubela, B., Philip, P., and Gilbert, T., 1984, Effect of microbial activity on buried cyanobacterial matter: *Geomicrobiology Journal*, v. 3, p. 231-244.

- Buchbinder, B., 1981, Morphology, microfabric and origin of stromatolites of the Pleistocene precursor of the Dead Sea, Israel: *in* Monty, C. L. V., ed., *Phanerozoic Stromatolites*: New York, Springer-Verlag, p. 181-196.
- Buck, J. D., and Greenfield, L. J., 1964, Calcification in marine-occurring yeasts: *Bulletin of Marine Science of the Gulf and Caribbean*, v. 14, p. 239-245.
- Buczynski, C., and Chafetz, H. S., 1989, Bacterially induced precipitates of calcium carbonate from algal tidal flats (abst.): *in* Rezak, R., and Winsborough, B., eds., *Texas-Mexico Stromatolite Field Conference*, Austin, Texas, 1989, p. 44.
- Caldwell, D. E., and Caldwell, S. J., 1978, Bacteriological characterization of phytoplankton cell surfaces: *in* Krumbein, W. E., ed., *Environmental Biogeochemistry and Geomicrobiology Volume 1: The Aquatic Environment*: Ann Arbor, Ann Arbor Science Publishers Inc., p. 101-107.
- Camoin, G., and Maurin, A-F., 1988, Roles of micro-organisms (bacteria, cyanobacteria) in the formation of mud mounds. Examples from the Turonian strata of Jebels Bireno and Mrhila (Tunisia): *Comptes Rendus de l'Academie des Sciences*, Paris, t. 307, Serie II, p. 401-407.
- Carroll, J. J., Greenfield, L. J., and Johnson, R. F., 1965, The mechanism of calcium and magnesium uptake from sea water by a marine bacterium: *Journal of Cellular Comparative Physiology*, v. 66, p. 109-118.
- Cerda, M. E., 1973, Caliche textures and <<Microcodium>>: *Supplemento al Bollettino della Societ 'A Geologica Italiana*, v. 92, p. 105-125.
- Chafetz, H. S., 1986, Marine peloids: A product of bacterially induced precipitation of calcite: *Journal of Sedimentary Petrology*, v. 56, p. 812-817.
- Chafetz, H. S., and Folk, R. L., 1984, Travertines: Depositional morphology and the bacterially constructed constituents: *Journal of Sedimentary Petrology*, v. 54, p. 289-316.
- Chafetz, H. S., and Meredith, J. C., 1983, Recent travertine pisoliths (pisoids) from southeastern Idaho, U. S. A.: *in* Peryt, T. M., ed., *Coated Grains*: New York, Springer-Verlag, p. 450-455.

- Chafetz, H. S., Rush, P. F., and Utech, N. M., 1989, Geochemical and petrographic analysis of travertine precipitating waters and travertine deposits, Arbuckle Mountains, Oklahoma (abst.): American Association of Petroleum Geologists Bulletin, v. 73, p. 421.
- Cheney, E. S., and Jensen, M. L., 1965, Stable carbon isotopic composition of biogenic carbonates: *Geochimica et Cosmochimica Acta*, v. 29, p. 1331-1346.
- Christie, A. O., and Floodgate, G. D., 1966, Formation of microtrees on surfaces submerged by the sea: *Nature*, v. 212, p. 308-310.
- Cloud, P. E. Jr., 1962, Environment of calcium carbonate deposition west of Andros Island, Bahamas: U. S. Geological Survey Professional Papers #350, 138p.
- Dale, N. G., 1974, Bacteria in intertidal sediments: Factors related to their distribution: *Limnology and Oceanography*, v. 19, p. 509-518.
- Dalrymple, D. W., 1965, Calcium carbonate deposition associated with blue-green algal mats, Baffin Bay, Texas: University of Texas Institute of Marine Science, v. 10, p. 187-200.
- Danielli, H. M. C., 1981, The fossil alga *Girvanella* Nicholson & Etheridge: *Bulletin of the British Museum (Natural History)*, Geology Series, v. 35, p. 79-107.
- Danielli, H. M. C., and Edington, M. A., 1983, Bacterial calcification in limestone caves: *Geomicrobiology Journal*, v. 3, p. 1-16.
- Davies, P. J., Bubela, B., and Ferguson, J., 1977, Simulation of carbonate diagenetic processes: Formation of dolomite, huntite and monohydrocalcite by the reactions between nesquehonite and brine: *Chemical Geology*, v. 19, p. 187-214.
- Davies, P. J., Ferguson, J., and Bubela, B., 1975, Dolomite and organic material: *Nature*, v. 255, p. 472-474.
- Davis, J. B., and Kirkland, D. W., 1970, Native sulfur deposition in the Castile Formation, Culberson County, Texas: *Economic Geology*, v. 65, p. 107-121.

- Davis, J. B., and Kirkland, D. W., 1979, Bioepigenetic sulfur deposits: *Economic Geology*, v. 74, p. 462-468.
- Deelman, J. C., 1975a, Bacterial sulfate reduction affecting carbonate sediments: *Soil Science*, v. 119, p. 73-80.
- Deelman, J. C., 1975b, Two mechanisms of microbial carbonate precipitation: *Naturwissenschaften*, v. 62, p. 484-485.
- Dott, R. H. Jr., and Batten, R. L., 1971, *Evolution of the Earth*, Third Edition: New York, McGraw-Hill Book Company, 573p.
- Drew, G. H., 1911, The action of some denitrifying bacteria in tropical and temperate seas, and the bacterial precipitation of calcium carbonate in the sea: *Journal of the Marine Biological Association of the United Kingdom*, v. 9, p. 142-155.
- Drew, G. H., 1912, Report on investigations of marine bacteria carried out at Andros Island, Bahamas, West Indies: *Carnegie Institution of Washington Year Book*, v. 11, p. 136-144.
- Drew, G. H., 1913, On the precipitation of calcium carbonate in the sea by marine bacteria, and on the action of denitrifying bacteria in tropical and temperate seas: *Journal of the Marine Biological Association of the United Kingdom*, v. 9, p. 479-524.
- Drew, G. H., 1914, On the precipitation of calcium carbonate in the sea by marine bacteria, and on the action of denitrifying bacteria in tropical and temperate seas: *Carnegie Institution of Washington Publication #182*, p. 7-45.
- Druckman, Y., 1981, Sub-recent manganese-bearing stromatolites along shorelines of the Dead Sea: *in* Monty, C. L. V., ed., *Phanerozoic Stromatolites*: New York, Springer-Verlag, p. 197-208.
- Ehrlich, H. L., 1981, *Geomicrobiology*: New York, Marcel Dekker, Inc., 393p.
- Ennever, J., 1963, Microbiologic calcification: *Annals New York Academy of Sciences*, v. 109, p. 4-13.
- Ennever, J., and Creamer, H., 1967, Microbiologic calcification: Bone mineral and bacteria: *Calcified Tissue Research*, v. 1, p. 87-93.

- Ennever, J., Vogel, J. J., and Streckfuss, J. L., 1971, Synthetic medium for calcification of *Bacterionema matruchotii*: *Journal of Dental Research*, v. 50, p. 1327-1330.
- Ennever, J., Vogel, J. J., and Streckfuss, J. L., 1974, Calcification by *Escherichia coli*: *Journal of Bacteriology*, v. 119, p. 1061-1062.
- Estep, M. L. F., 1982, Stable isotopic composition of algae and bacteria that inhabit hydrothermal environments in Yellowstone National Park: Annual Report of the Director of the Geophysical Laboratory, Carnegie Institute of Washington 1981-2, p. 402-410.
- Feely, H. W., and Kulp, L. J., 1957, Origin of Gulf Coast salt-dome sulphur deposits: *Bulletin of the American Association of Petroleum Geologists*, v. 41, p. 1802-1853.
- Ferrer, M. R., Quevedo-Sarmiento, J., Bejar, V., Delgado, R., Ramos-Cormenzana, A., and Rivadeneyra, M. A., 1988, Calcium carbonate formation by *Deleya halophila*: Effect of salt concentration and incubation temperature: *Geomicrobiology Journal*, v. 6, p. 49-57.
- Field, R. M., 1932, Microbiology and the marine limestones (abst): *Bulletin of the Geological Society of America*, v. 43, p. 142-143.
- Fischer, A. G., 1965, Fossils, early life, and atmospheric history: *Proceedings of the National Academy of Sciences of the United States of America*, v. 53, p. 1205-1215.
- Flajs, G., 1977, Skeletal structures of some calcifying algae: in Flugel, E., ed., *Fossil Algae Recent Results and Developments*: New York, Springer-Verlag, p. 225-231.
- Folk, R. L., 1974, The natural history of crystalline calcium carbonate: Effect of magnesium content and salinity: *Journal of Sedimentary Petrology*, v. 44, p. 40-53.
- Folk, R. L., 1986, White card and smoking gun: Bacteriodiagenetic nodules in the Triassic Portoro Limestone of Liguria, Italy (abst): *Geological Society of America, Abstracts with Programs*, v. 18, p. 604.
- Folk, R. L., and Chafetz, H. S., 1980, Quaternary travertine of Tivoli, (Roma), Italy: Bacterially-constructed carbonate rock (abst.): *Geological Society of America, Abstracts with Programs*, v. 12, p. 428.

- Folk, R. L., and Chafetz, H. S., 1983, Pisoliths (pisoids) in Quaternary travertines of Tivoli, Italy: *in* Peryt, T. M., ed., Coated Grains: New York, Springer-Verlag, p. 474-487.
- Folk, R. L., Chafetz, H. S., and Tiezzi, P. A., 1985, Bizarre forms of depositional and diagenetic calcite in hot-spring travertines, central Italy: *in* Schneidermann, N., and Harris, P. M., eds., Carbonate Cements: Tulsa, Society of Economic Paleontologists and Mineralogists Special Publication #36, p. 349-369.
- Friedman, G. M., 1966, Occurrence and origin of Quaternary dolomite of Salt Flat, West Texas: *Journal of Sedimentary Petrology*, v. 36, p. 263-267.
- Friedman, G. M., 1972a, Original and secondary pores in sedimentary reservoir rocks: Relation to CaCO_3 cements (abst): *American Association of Petroleum Geologists Bulletin*, v. 56, p. 1907-1908.
- Friedman, G. M., 1972b, Significance of Red Sea in problem of evaporites and basinal limestones: *American Association of Petroleum Geologists Bulletin*, v. 56, p. 1072-1086.
- Friedman, G. M., 1975, Address of the retiring president, Society of Economic Paleontologists and Mineralogists. The making and unmaking of limestones or the downs and ups of porosity: *Journal of Sedimentary Petrology*, v. 45, p. 379-398.
- Friedman, G. M., Amiel, A. J., Braun, M., and Miller, D. C., 1973, Generation of carbonate particles and laminites in algal mats - example from sea-marginal hypersaline pool, Gulf of Aqaba, Red Sea: *American Association of Petroleum Geologists Bulletin*, v. 57, p. 541-557.
- Friedman, G. M., Amiel, A. J., and Schneidermann, N., 1974, Submarine cementation in reefs: Example from the Red Sea: *Journal of Sedimentary Petrology*, v. 44, p. 816-825.
- Friedman, G. M., and Sanders, J. E., 1978, *Principles of Sedimentology*: New York, John Wiley & Sons, 792p.
- Friedman, G. M., Sneh, A., and Owen, R. W., 1985, The Ras Muhammad Pool: Implications for the Gavish Sabkha: *in* Friedman, G. M., and Krumbein, W. E., eds., Hypersaline Ecosystems, The Gavish Sabkha: New York, Springer-Verlag, p. 218-237.

- Gary, M., McAfee, R. Jr., and Wolf, C. L., eds., 1974, Glossary of Geology: Washington D. C., American Geological Institute, 805p.
- Gebelein, C. D., 1976, The effects of the physical, chemical and biological evolution of the earth: *in* Walter, M. R., ed., *Stromatolites: Developments in Sedimentology 20*: Amsterdam, Elsevier, p. 499-515.
- Gebelein, C. D., and Hoffman, P., 1971, Algal origin of dolomite in interlaminated limestone-dolomite sedimentary rocks: *in* Bricker, O. P., ed., *Carbonate Cements*: Baltimore, Johns Hopkins Press, p. 319-326.
- Gee, H., 1932, Lime deposition and the bacteria. I. Estimate of bacterial activity at the Florida Keys: Carnegie Institution of Washington Publication #435, p. 67-82.
- Gee, H., and Feltham, C. B., 1932, Lime deposition and the bacteria. II Characteristics of aerobic bacteria from the Florida Keys: Carnegie Institution of Washington Publication #435, p. 83-91.
- Gerundo, M., and Schwartz, G. L., 1949, The role of denitrifying bacteria in the genesis of formations found in the Carlsbad Cavern: *Texas Journal of Science*, v. 1, #4, p. 58-61.
- Given, R. K., and Wilkinson, B. H., 1985, Kinetic control of morphology, composition, and mineralogy of abiotic sedimentary carbonates: *Journal of Sedimentary Petrology*, v. 55, p. 109-119.
- Golubic, S., 1973, The relationship between bluegreen algae and carbonate deposits: *in* Carr, N. G., and Whitton, B. A., eds., *The Biology of Blue-Green Algae*: Los Angeles, Blackwell Scientific Publications, p. 434-472.
- Golubic, S., 1976a, Organisms that build stromatolites: *in* Walter, M. R., ed., *Stromatolites: Developments in Sedimentology 20*: Amsterdam, Elsevier, p. 113-126.
- Golubic, S., 1976b, Taxonomy of extant stromatolite-building Cyanophytes: *in* Walter, M. R., ed., *Stromatolites: Developments in Sedimentology 20*: Amsterdam, Elsevier, p. 127-140.

- Golubic, S., and Barghoorn, E. S., 1977, Interpretation of microbial fossils with special reference to the Precambrian: *in* Flugel, E., ed., *Fossil Algae Recent Results and Developments*: New York, Springer-Verlag, p. 1-14.
- Golubic, S., and Campbell, S. E., 1981, Biogenically formed aragonite concretions in marine rivularia: *in* Monty, C. L. V., ed., *Phanerozoic Stromatolites*: New York, Springer-Verlag, p. 209-229.
- Golubic, S., and Hofmann, H. J., 1976, Comparison of Holocene and Mid-Precambrian *Entophysalidaceae* (Cyanophyta) in stromatolitic algal mats: Cell division and degradation: *Journal of Paleontology*, v. 50, p. 1074-1082.
- Greenfield, L. J., 1963, Metabolism and concentration of calcium and magnesium and precipitation of calcium carbonate by a marine bacterium: *Annals of the New York Academy of Science*, v. 109, p. 23-45.
- Gunkel, W., and Rheinheimer, G., 1968, Baktierien: *in* C. Schlieper, Jena, ed., *Methoden der Meeresbiologischen Forschung*, VEB Fischer, p. 142-157 and p. 243-255. (from Krumbein, 1971)
- Hall, A. D., and Miller, N. H. J., 1905, The effect of plant growth and of manures upon the retention of bases by the soil: *Proceedings of the Royal Society of London, Section B*, v. 77, p. 1-32.
- Hatch, F. H., Rastall, R. H., and Black, M., 1938, *The Petrology of Sedimentary Rocks*: London, Thomas Murby & Co., 383p.
- Hewitt, H. B., 1947, Bacterial "calculi": *Journal of Pathology and Bacteriology*, v. 59, p. 657-664.
- Horodyski, R. J., Bloeser, B., and Vonder Haar, S., 1977, Laminated algal mats from a coastal lagoon, Laguna Mormona, Baja California, Mexico: *Journal of Sedimentary Petrology*, v. 47, p. 680-696.
- Jones, B., and Ng, K-C., 1988, The structure and diagenesis of rhizoliths from Cayman Brac, British West Indies: *Journal of Sedimentary Petrology*, v. 58, p. 457-467.
- Jones, G. E., Starkey, R. L., Feely, H. W., and Kulp, J. L., 1956, Biological origin of native sulfur in salt domes of Texas and Louisiana: *Science*, v. 123, p. 1124-1125.

- Jorgensen, B. B., and Cohen, Y., 1978, Sulfate reduction in cyanobacterial mats of Solar Lake (Sinai): *in* Krumbein, W. E., ed., Environmental Biogeochemistry and Geomicrobiology Volume 1: The Aquatic Environment: Ann Arbor, Ann Arbor Science Publishers Inc., p. 203-207.
- Jorgensen, B. B., and Revesbech, N. P., 1983, Colorless sulfur bacteria, *Beggiatoa* spp. and *Thiovulum* spp., in O₂ and H₂S microgradients: Applied and Environmental Microbiology, v. 45, p. 1261-1270.
- Kaplan, I. R., and Rittenberg, S. C., 1964, Carbon isotope fractionation during metabolism of lactate by *Desulfovibrio desulfuricans*: Journal General Microbiology, v. 34, p. 213-217.
- Kazmierczak, J., and Krumbein, W. E., 1983, Identification of calcified coccoid cyanobacteria forming stromatoporoid stromatolites: Lethaia, v. 16, p. 207-213.
- Keller, A., 1958, Morphology of crystalline polymers: *in* Doremus, R. H., Roberts, B. W., and Turnbull, D., eds., Growth and Perfection of Crystals, New York, John Wiley & Sons, Inc., p. 499-532.
- Kellerman, K. F., 1915, Relation of bacteria to deposition of calcium carbonate (abst): Bulletin of the Geological Society of America, v. 26, p. 58.
- Kellerman, K. F., and Smith, N. R., 1914, Bacterial precipitation of calcium carbonate: Journal of the Washington Academy of Science, v. 4, p. 400-402
- Kennard, J. M., and James, N. P., 1986, Thrombolites and stromatolites: Two distinct types of microbial structures: Palaios, v. 1, p. 492-503.
- Kitano, Y., 1962a, The behavior of various inorganic ions in the separation of calcium carbonate from a bicarbonate solution: Chemical Society of Japan Bulletin, v. 35.2, p. 1973-1980.
- Kitano, Y., 1962b, A study of polymorphic formation of calcium carbonate in thermal springs with an emphasis on the temperature: Chemical Society of Japan Bulletin, v. 35.2, p. 1980-1985.

- Kitano, Y., 1964, On factors influencing the polymorphic crystallization of calcium carbonate found in marine biological systems: *in* Miyake, Y., and Koyama, T., eds., Recent Researches in the fields of hydrosphere, atmosphere and nuclear geochemistry: Tokyo, Maruzen Co. Ltd., p. 305-319.
- Kitano, Y., and Hood, D. W., 1965, The influence of organic material on the polymorphic crystallization of calcium carbonate: *Geochimica et Cosmochimica Acta*, v. 29, p. 29-41.
- Kitano, Y., Kanamori, N., and Tokuyama, A., 1970, Influence of organic mater on inorganic precipitation: *in* Wood, D. H., ed., Organic Matter in Natural Waters: University of Alaska Institute of Marine Science Occasional Publications, #1, p. 413-447.
- Kitano, Y., Kanamori, N., and Yoshioka, S., 1976, Influence of chemical species on the crystal type of calcium carbonate: *in* Watabe, N., and Wilbur, K. M., eds., The Mechanisms of Mineralization in the Invertebrates and Plants: Columbia, South Carolina, University of South Carolina Press, p. 191-202.
- Klappa, C. F., 1979, Calcified filaments in Quaternary calcretes: Organo-mineral interaction in the subaerial vadose environment: *Journal of Sedimentary Petrology*, v. 49, p. 955-968.
- Kobluk, D. R., and Risk, M. J., 1977, Calcification of exposed filaments of endolithic algae, micritic envelope formation and sediment production: *Journal of Sedimentary Petrology*, v. 47, p. 517-528.
- Kocurko, J. M., 1986, Interaction or organic mater and crystallization of high magnesian calcite, South Louisiana: *Society of Economic Paleontologists and Mineralogists Bulletin*, v. 13, p. 13-21.
- Krumbein, W. E., 1968, Geomicrobiology and geochemistry of the "Nari-lime-crust" (Israel): *in* Muller, G., and Friedman, G. M., eds., Recent Developments in Carbonate Sedimentology in Central Europe: New York, Springer-Verlag, p. 138-147.
- Krumbein, W. E., 1969, Uber den Einfluss der Mikroflora auf die exogene Dynamik (Verwitterung und Krustenbildung): *Geologische Rundschau*, v. 58, p. 333-363.

- Krumbein, W. E., 1971, Sediment microbiology and grain-size distribution, as related to tidal movement, during the first mission of the West German Underwater Laboratory "Helgoland": *Marine Biology*, v. 10, p. 101-112.
- Krumbein, W. E., 1974, On the precipitation of aragonite on the surface of marine bacteria: *Naturwissenschaften*, v. 61, p. 167.
- Krumbein, W. E., 1978, Algal mats and their lithification: *in* Krumbein, W. E., ed., *Environmental Biogeochemistry and Geomicrobiology Volume 1: The Aquatic Environment*: Ann Arbor, Ann Arbor Science Publishers Inc., p. 209-225.
- Krumbein, W. E., 1979a, Calcification by bacteria and algae: *in* Trudinger, P. A., and Swaine, D. J., eds., *Biogeochemical Cycling of Mineral-Forming Elements: Studies in Environmental Science, #3*: New York, Elsevier, p. 47-68.
- Krumbein, W. E., 1979b, Photolithotropic and chemoorganotrophic activity of bacteria and algae as related to beachrock formation and degradation (Gulf of Aqaba, Sinai): *Geomicrobiology Journal*, v. 1, p. 139-203.
- Krumbein, W. E., and Cohen, Y., 1974, Biogene, klastische und evaporitische Sedimentation in einem mesothermen monomiktischen ufernahen See (Golf von Aqaba): *Geologische Rundschau*, v. 63, p. 1035-1065.
- Krumbein, W. E., and Cohen, Y., 1977, Primary production, mat formation and lithification: Contributions of oxygenic and facultative anoxygenic cyanobacteria: *in* Flugel, E., ed., *Fossil Algae Recent Results and Developments*: New York, Springer-Verlag, p. 37-56.
- Krumbein, W. E., Cohen, Y., and Shilo, M., 1977, Solar Lake (Sinai). 4. Stromatolitic cyanobacterial mats: *Limnology and Oceanography*, v. 22, p. 635-656.
- Krumbein, W. E., and Potts, M., 1979, Girvanella-like structures formed by *Plectonema gloeophilum* (cyanophyta) from the Borrego Desert in Southern California: *Geomicrobiology Journal*, v. 1, p. 211-217.
- Krumbein, W. E., and Swart, P. K., 1983, The microbial carbon cycle: *in* Krumbein, W. E., ed., *Microbial Geochemistry*: Oxford, Blackwell Scientific Publishers, p. 5-62.

- Lalou, C., 1954a, Sur la precipitation experimentale de la calcite dans les vases de la baie de Villefranche-sur-Mer: Comptes Rendus de l'Academie des Sciences, v. 238, p. 603-605.
- Lalou, C., 1954b, Sur les formes cristallines observees dans les voiles calcaires formes par cultures bacteriennes a partir de vases noires de Villefranche-sur-Mer (Alpes-maritimes): Comptes Rendus de l'Academie des Sciences, v. 238, p. 2329-2330.
- Lalou, C., 1954c, Sur un mecanisme bacterien possible dans la formation des depots de carbonates depourvus d'organismes: Comptes Rendus somm. Soc. Geol., seance du 29, nov. (from Lalou, 1957a)
- Lalou, C., 1957a, Etude experimentale de la production de carbonates par les bacteries des vases de la baie de Villefranche-sur-Mer: Annals de L'Institut Oceanographique, t. 33, p. 201-267.
- Lalou, C., 1957b, Studies on bacterial precipitation of carbonates in sea water: Journal of Sedimentary Petrology, v. 27, p. 190-195.
- Land, L. S., Behrens, E. W., and Frishman, S. A., 1979, The ooids of Baffin Bay, Texas: Journal of Sedimentary Petrology, v. 49, p. 1268-1278.
- Lein, A. Y., 1978, Formation of carbonate and sulfide minerals during diagenesis of reduced sediments: *in* Krumbein, W. E., ed., Environmental Biogeochemistry and Geomicrobiology Volume 1: The Aquatic Environment: Ann Arbor, Ann Arbor Science Publishers Inc., p. 339-354.
- Lipman, C. B., 1920, Studies on sea-water bacteria and other subjects in the South Seas: Carnegie Institution of Washington Year Book, v. 19, p. 196-197.
- Lipman, C. B., 1924, A critical and experimental study of Drew's bacterial hypothesis on CaCO_3 precipitation in the sea: Carnegie Institution of Washington Publication #340, v. 19, p. 179-191.
- Lipman, C. B., 1929, Further studies on marine bacteria with special reference to the Drew hypothesis of CaCO_3 precipitation in the sea: Carnegie Institution of Washington Publication #391, p. 231-248.

- Lipman, C. B., 1931, The possible role of micro-organisms in the precipitation of calcium carbonate in tropical seas: *Science*, v. 74, p. 150-151.
- Lowenstam, H. A., and Weiner, S., 1989, *On Biomineralization*: New York, Oxford University Press, 324p.
- Lyons, W. B., Long, D. T., Hines, M. E., Gaudette, H. E., and Armstrong, P. B., 1984, Calcification of cyanobacterial mats in Solar Lake, Sinai: *Geology*, v. 12, p. 623-626.
- Machel, H. G., and Mountjoy, E. W., 1986, Chemistry and environments of dolomitization - A reappraisal: *Earth Science Reviews*, v. 23, p. 175-222.
- MacIntyre, I. G., and Videtich, P. E., 1979, Pseudostalactites from submarine cave near Columbus Cay, Belize barrier reef complex - Evidence of extensive submarine lithification (abst): *American Association of Petroleum Geologists Bulletin*, v. 63, p. 489.
- Malone, P. G., and Towe, K. M., 1970, Microbial carbonate and phosphate precipitates from sea water cultures: *Marine Geology*, v. 9, p. 301-309.
- Mansfield, C. F., 1980, A urolith of biogenic dolomite - another clue in the dolomite mystery: *Geochimica et Cosmochimica Acta*, v. 44, p. 829-839.
- Maurin, A. F., and Noel, D., 1977, A possible bacterial origin for Famennian micrites: *in* Flugel, E., ed., *Fossil Algae Recent Results and Developments*: New York, Springer-Verlag, p. 136-142.
- Maurin, A. F., Philip, J., and Brunel, P., 1981, Possible microbial accretions in Cenomanian mounds, S. E. France: *in* Monty, C. L. V., ed., *Phanerozoic Stromatolites*: New York, Springer-Verlag, p. 121-133.
- May, J. A., and Perkins, R. D., 1979, Endolithic infestation of carbonate substrates below the sediment-water interface: *Journal of Sedimentary Petrology*, v. 49, p. 357-378.
- McCallum, M. F., and Guhathakurta, K., 1970, The precipitation of calcium carbonate from seawater by bacteria isolated from Bahama Bank sediments: *Journal of Applied Bacteriology*, v. 33, p. 649-655.

- McCunn, H. J., 1972, Calcite and aragonite phenomena precipitated by organic decay in high lime concentrate brines: *Journal of Sedimentary Petrology*, v. 42, p. 150-154.
- McKirdy, D. M., 1976, Biochemical markers in stromatolites: *in* Walter, M. R., ed., *Stromatolites: Developments in Sedimentology 20*: Amsterdam, Elsevier, p. 163-191.
- Meredith, J. C., 1980, Diagenesis of Holocene-Pleistocene (?) travertine deposits: Fritz Creek, Clark County and Fall Creek, Bonneville County, Idaho: Univerisy of Houston Unpublished MS Thesis, 263p.
- Monaghan, P. H., and Lytle, M. L., 1956, The origin of calcareous ooliths: *Journal of Sedimentary Petrology*, v. 26, p. 111-118.
- Monty, C. L. V., 1965, Geological and environmental significance of Cyanophyta: Unpublished Ph. D. Dissertation, Princeton University, Princeton, New Jersey, 408p.
- Monty, C. L. V., 1967, Distribution and structure of recent stromatolitic algal mats, Eastern Andros Island, Bahamas: *Annales de la Societe Geologique de Belgique*, T. 90, p. 55-101.
- Monty, C. L. V., 1972, Recent algal stromatolitic deposits, Andros Island, Bahamas. Preliminary report: *Geologische Rundschau*, v. 61, p. 742-783.
- Monty, C. L. V., 1976, The origin and development of cryptalgal fabrics: *in* Walter, M. R., ed., *Stromatolites: Developments in Sedimentology 20*: Amsterdam, Elsevier, p. 193-250.
- Monty, C. L. V., ed., 1981, *Phanerozoic Stromatolites*: New York, Springer-Verlag, 249p.
- Monty, C. L. V., 1982, Microbial spars (abst.): *International Association of Sedimentologists Abstracts of Papers, Eleventh International Congress on Sedimentology*, p. 26.
- Monty, C. L. V., and Hardie, L. A., 1976, The geological significance of the freshwater blue-green algal calcareous marsh: *in* Walter, M. R., ed., *Stromatolites: Developments in Sedimentology 20*: Amsterdam, Elsevier, p. 447-477.

- del Moral, A., Roldan, E., Navarro, J., Monteoliva-Sanchez, M., and Ramos-Cormenzana, A., 1987, Formation of calcium carbonate crystals by moderately halophilic bacteria: *Geomicrobiology Journal*, v. 5, p. 79-87.
- Morita, R. Y., 1980, Calcite precipitation by marine bacteria: *Geomicrobiology Journal*, v. 2, p. 63-82.
- Morita, R. Y., Cuff, C., and Patrick, J., 1975, Anaerobic microbial precipitation of calcite: A preliminary study (abst.): Abstracts of the Annual Meeting, 1975, American Society for Microbiology, p. 190.
- Mucci, A., 1987, Influence of temperature on the composition of magnesian calcite overgrowths precipitated from seawater: *Geochimica et Cosmochimica Acta*, v. 51, p. 1977-1984.
- Myroie, J. E., 1983, Caves and Karst of San Salvador: *in* Gerace, D. T., ed., *Field Guide to the Geology of San Salvador*, Third Edition: U. S. A., College Center of the Finger Lakes Bahamian Field Station, p. 67-96.
- Nadson, G. A., 1903, Microorganisms as geologic agents I: Tr. Komissi Isslect. Min. Vod g. Slavyanska, St. Petersburg. (from Nadson, 1928)
- Nadson, G. A., 1928, Beitrag zur Kenntnis der bakteriogenen Kalkablagerungen: *Archiv fur Hydrobiologie*, v. 19, p. 154-164.
- Novitsky, J. A., 1981, Calcium carbonate precipitation by marine bacteria: *Geomicrobiology Journal*, v. 2, p. 375-388.
- Oppenheimer, C. H., 1961, Note on the formatin of spherical aragonite bodies in the presence of bacteria from the Bahama Bank: *Geochimica et Cosmochimica Acta*, v. 23, p. 295-296.
- Park, R. K., 1977, The preservation potential of some recent stromatolites: *Sedimentology*, v. 24, p. 485-506.
- Pautard, F. G. E., 1970, Calcification in unicellular organisms: *in* Schraer, H., ed., *Biological Calcification*: Amsterdam, North Holland, p. 105-201.
- Pentecost, A., 1978, Blue-green algae and freshwater carbonate deposits: *Proceedings of the Royal Society of London, Series B*, v. 200, p. 43-61.

- Pentecost, A., and Bauld, J., 1988, Nucleation of calcite on the sheaths of cyanobacteria using a simple diffusion cell: *Geomicrobiology Journal*, v. 6, p. 129-135.
- Pentecost, A., and Riding, R., 1986, Calcification in cyanobacteria: *in* Leadbeater, B. S. C., and Riding, R., eds., *Biom mineralization in Lower Plants and Animals*: Oxford, Clarendon Press, p. 73-90.
- Piccoli, G., Varese, M., and Rotunno, M., 1984, *Atlas of Urinary Sediments, Diagnosis and Clinical Correlations in Nephrology*: New York, Raven Press, 210p.
- Polaron E3000 Critical Point Drying Apparatus, 1985, Instruction manual: 17p.
- Pratt, B. R., 1984, *Epiphyton and Renalcis* - Diagenetic microfossils from calcification of coccoid blue-green algae: *Journal of Sedimentary Petrology*, v. 54, p. 948-971.
- Press, F., and Siever, R., 1982, *Earth*, Third Edition: San Francisco, W. H. Freeman and Company, 613p.
- Purdy, E. G., 1963, Recent calcium carbonate facies of the Great Bahama Bank. 2. Sedimentary facies: *Journal of Geology*, v. 71, p. 472-497.
- Puri, H. S., and Collier, A., 1967, Role of micro-organisms in formation of limestones: *Transactions of the Gulf Coast Association Geological Society*, v. 17, p. 355-367.
- Pursell, V. J., 1985, The petrology and diagenesis of Pleistocene and recent travertines from Gardiner, Montana, and Yellowstone National Park: University of Texas at Austin, Unpublished MA Thesis, 153p.
- Raiswell, R., 1976, The microbiological formation of carbonate concretions in the Upper Lias of NE England: *Chemical Geology*, v. 18, p. 227-244.
- Ramos-Cormenzana, A., 1975, Formation of calcite crystals by bacteria of the genus *Bacillus*: *Microbios*, v. 13, p. 61-70.
- Rickard, D. T., 1969, The microbiological formation of iron sulphides: *Stockholm Contributions in Geology*, v. 20, p. 49-66.

- Rivadeneira, M. A., Ramos-Cormenzana, A., and Garcia-Cervigon, A., 1983, Bacterial formation of struvite: *Geomicrobiology Journal*, v. 3, p. 151-163.
- Roberts, H. H., Sassen, R., Aharon, P., and Carney, R., 1989, C¹³-depleted authigenic carbonate buildups from hydrocarbon seeps, Louisiana continental slope (abst): American Association of Petroleum Geologists Annual Meeting, p. 90-91.
- Rodina, A. G., translated, edited, and revised by Colwell, R. R., and Zambruski, M. S., 1972, *Methods in Aquatic Microbiology*: Baltimore, University Park Press, 461p.
- Ruckmick, J. C., Wimberly, B. H., and Edwards, A. F., 1979, Classification and genesis of biogenic sulfur deposits: *Economic Geology*, v. 74, p. 469-477.
- Sassen, R., 1980, Biodegradation of crude oil and mineral deposition in a shallow Gulf Coast salt dome: *Organic Geochemistry*, v. 2, p. 153-166.
- Schidlowski, M., Matzigkeit, U., Mook, W. G., and Krumbein, W. E., 1985, Carbon isotope geochemistry and ¹⁴C ages of microbial mats from the Gavish Sabkha and the Solar Lake: *in* Friedman, G. M., and Krumbein, W. E., eds., *Hypersaline Ecosystems, The Gavish Sabkha*: New York, Springer-Verlag, p. 381-401.
- Schneider, J., 1977, Carbonate construction and decomposition by epilithic and endolithic micro-organisms in salt- and freshwater: *in* Flugel, E., ed., *Fossil Algae*: New York, Springer-Verlag, p. 248-260.
- Scholle, P. A., 1978, *A Color Illustrated Guide to Carbonate Rock Constituents, Textures, Cements, and Porosities*: Tulsa, American Association of Petroleum Geologists, 241p.
- Shinano, H., 1972a, Studies of marine microorganisms taking part in the precipitation of calcium carbonate-II. Detection and grouping of the microorganisms taking part in the precipitation of calcium carbonate: *Bulletin of the Japanese Society of Scientific Fisheries*, v. 38, p. 717-725.

- Shinano, H., 1972b, Studies of marine microorganisms taking part in the precipitation of calcium carbonate-III. A taxonomic study of marine bacteria taking part in the precipitation of calcium carbonate (1): Bulletin of the Japanese Society of Scientific Fisheries, v. 38, p. 727-732.
- Shinano, H., 1972c, Studies of marine microorganisms taking part in the precipitation of calcium carbonate-IV. A taxonomic study of marine bacteria taking part in the precipitation of calcium carbonate (2): Bulletin of the Japanese Society of Scientific Fisheries, v. 38, p. 825-832.
- Shinano, H., 1972d, Studies of marine microorganisms taking part in the precipitation of calcium carbonate-V. A taxonomic study of marine bacteria taking part in the precipitation of calcium carbonate (3): Bulletin of the Japanese Society of Scientific Fisheries, v. 38, p. 833-838.
- Shinano, H., and Sakai, M., 1969, Studies of marine bacteria taking part in the precipitation of calcium carbonate-I. Calcium carbonate deposited in peptone medium prepared with natural sea water and artificial sea water: Bulletin of the Japanese Society of Scientific Fisheries, v. 35, p. 1001-1005.
- Shinano, H., and Sakai, M., 1975, Effect of magnesium ion concentration on the types of crystals deposited by marine bacteria in sea water: Bulletin of the Japanese Society of Scientific Fisheries, v. 41, p. 913.
- Simkiss, K., and Wilbur, K. M., 1989, Biomineralization, Cell Biology and Mineral Deposition: New York, Academic Press Inc., 337p.
- Steinen, R. P., Gray, N. H., and Mooney, J., 1987, A Mesozoic carbonate hot-spring deposit in the Hartford Basin of Connecticut: Journal of Sedimentary Petrology, v. 57, p. 319-326.
- Takeichi, M., and Okada, T. S., 1972, Roles of magnesium and calcium ions in cell-to-substrate adhesion: Experimental Cell Research, v. 74, p. 51-60.
- Taylor, J., and Parkes, R. J., 1985, Identifying different populations of sulphate-reducing bacteria within marine sediment systems, using fatty acid biomarkers: Journal of General Microbiology, v. 131, p. 631-642.

- Tiezzi, P. A., and Folk, R. L., 1984, Vacuole-rich cements in Mississippian Stromatactis and Quaternary travertines: The ?bacterial connection: Society of Economic Paleontologists and Mineralogists, 1st Annual Midyear Meeting, San Jose, California, program, p. 82.
- Towe, K. M., and Malone, P. G., 1970, Precipitation of metastable carbonate phases from seawater: *Nature*, v. 226, p. 348-349.
- Trudinger, P. A., and Mendelsohn, F., 1976, Biological processes and mineral deposition: *in* Walter, M. R., ed., *Stromatolites: Developments in Sedimentology 20*: Amsterdam, Elsevier, p. 663-672.
- Trudinger, P. A., Swaine, D. J., and Skyring, G. W., 1979, Biogeochemical cycling of elements - General considerations: *in* Trudinger, P. A., and Swaine, D. J. eds., *Biogeochemical Cycling of Mineral-Forming Elements: Studies in Environmental Science #3*: New York, Elsevier, p. 1-27.
- Tsien, H. H., 1985, Algal-bacterial origin of micrites in mud mounds: *in* Toomey, D. F., and Nitecki, M. H., eds., *Paleoalgology, Contemporary Research and Applications*: New York, Springer-Verlag, p. 290-296.
- Urist, M. R., 1973, Biologic initiators of calcification: *in* Zipkin, I., ed., *Biological Mineralization*: New York, John Wiley & Sons Inc., p. 757-805.
- Vanyo, J. P., Hutchinson, R. A., and Awramik, S. M., 1986, Heliotropism in microbial stromatolitic growths at Yellowstone National Park: Geophysical inferences: *EOS, Transactions, American Geophysical Union*, v. 67, p. 153, 155-156.
- Vaughan, T. W., 1914, Preliminary remarks on the geology of the Bahamas: Carnegie Institution of Washington Publication #182, v. 5, p. 47-54.
- Walter, L. M., 1986, Relative efficiency of carbonate dissolution and precipitation during diagenesis: A progress report on the role of solution chemistry: *in* Gautier, D. L., ed., *Roles of Organic Matter in Sediment Diagenesis*: Tulsa, The Society of Economic Paleontologists and Mineralogists Special Publication #38, p. 1-11.

- Whitton, B. A., 1973, Interactions with other organisms: *in* Carr, N. G., and Whitton, B. A., eds., *The Biology of Blue-Green Algae*: Oxford, Blackwell Press, p. 415-433.
- Wind, F. H., and Wise, S. W. Jr., 1976, Organic vs. inorganic processes in archaeogastropod shell mineralization: *in* Watabe, N., and Wilbur, K. M., eds., *The Mechanisms of Mineralization in the Invertebrates and Plants*: Columbia, South Carolina, University of South Carolina Press, p. 369-387.
- Wollny 1897, Zersetzung der organischen Stoffe: (from Hall and Miller, 1905)
- Wood, E. J. F., 1967, *Marine Microbial Ecology*: New York, Reinhold Publishing Corporation, 243p.
- Zeller, E. J., and Wray, J. L., 1956, Factors influencing precipitation of calcium carbonate: *American Association of Petroleum Geologists Bulletin*, v. 40, p. 140-152.
- ZoBell, C. E., 1938, Studies on the bacterial flora of marine bottom sediments: *Journal of Sedimentary Petrology*, v. 8, p. 10-18.
- ZoBell, C. E., 1939, Occurrence and activity of bacteria in marine sediments: *in* Trask, P. D., ed., *Recent Marine Sediments, A Symposium*: Tulsa, American Association of Petroleum Geologists, p. 416-427.
- ZoBell, C. E., 1941, Studies on marine bacteria. I. The cultural requirements of heterotrophic aerobes: *Journal of Marine Research*, v. 4, p. 42-75.
- ZoBell, C. E., 1946, *Marine Microbiology: A Monograph on Hydrobacteriology*: Chronica Botanica Co., Waltham, Mass., 240p.
- ZoBell, C. E., 1963, Organic geochemistry of sulfur: *in* Berger, I. A., ed., *Organic Geochemistry, Monograph 16, Earth Science Series*: New York, Pergamon Press, p. 543- 578.

ADDITIONAL REFERENCES

The following list contains references which were not cited in the text. Many may be of peripheral interest to other researchers. The few citations which could not be obtained have their source listed in parentheses after the citation so that the reader may consult it directly.

- Allen, R. C., Gavish, E., Friedman, G. M., and Sanders, J. E., 1969, Aragonite-cemented sandstone from the outer continental shelf off Delaware Bay: Submarine lithification mechanism yields product resembling beachrock: *Journal of Sedimentary Petrology*, v. 39, p. 136-149.
- Ashirov, K. B., 1962, Life activity of formational microflora as an index of geologic environment and processes in pteridiferous formations: *in* Kuznetsov, S. I., ed., *Geologic Activity of Microorganisms*, Transactions of the Institute of Microbiology, #9, p. 84-91. (from Sassen, 1980)
- Awramik, S. M., 1984, Ancient stromatolites and microbial mats: *in* Cohen, Y., Castenholtz, R. W., and Halvorson, H. O., eds., *Microbial Mats: Stromatolites*: New York, Alan R. Liss, Inc., p. 1-22.
- Awramik, S. M., Gebelein, C. D., and Cloud, P., 1978, Biogeologic relationships of ancient stromatolites and modern analogs: *in* Krumbein, W. E., ed., *Environmental Biogeochemistry and Geomicrobiology Volume 1: The Aquatic Environment*: Ann Arbor, Ann Arbor Science Publishers Inc., p. 165-178.
- Awramik, S. M., Margulis, L., and Barghoorn, E. S., 1976, Evolutionary processes in the formation of stromatolites: *in* Walter, M. R., ed., *Stromatolites: Developments in Sedimentology 20*: Amsterdam, Elsevier, p. 149-162.
- Bathurst, R. G. C., 1967, Sub-tidal gelatinous mat, sand stabilizer, and food, Great Bahama Bank: *Journal of Geology*, v. 75, p. 736-738.
- Bavendamm, W., 1931, Die Frage der Bakteriologischen Kalkfallung in der tropischen See: *Berichte der Deutschen Botanischen Gesellschaft*, v. 49, p. 282-287. (from Lalou, 1957a)

- Beales, F. W., 1958, Ancient sediments of Bahaman type: American Association of Petroleum Geologists Bulletin, v. 42, p. 1845-1880.
- Billy, C., 1967, Alginolyse et association bacterienne en milieu marin: Vie et Milieu, Serie A, v. 18, p. 1-26.
- Birnbaum, S. J., and Wireman, J. W., 1984, Bactrial sulfate reduction and pH: Implications for early diagenesis: Chemical Geology, v. 43, p. 143-149.
- Brock, T. D., 1967, Life at high temperatures: Science, v. 158, p. 1012-1019.
- Brock, T. D., 1976, Biological techniques for the study of microbial mats and living stromatolites: *in* Walter, M. R., ed., Stromatolites: Developments in Sedimentology 20: Amsterdam, Elsevier, p. 21-30.
- Brussof, A., 1933a, Sur une bacterie accumulant du calcaire et sur les cristaux qu'elle forme: Archiv fur Mikrobiologie, v. 4, p. 170-188. (from Lalou, 1957a)
- Brussof, A., 1933b, Ueber ein Kieselbakterium: Archiv fur Mikrobiologie, v. 4, p. 1. (from Lalou, 1957a)
- Buckley, H. E., 1951, Crystal Growth: New York, John Wiley & Sons, 571p.
- Burne, R. V., and Moore, L. S., 1987, Microbialites: Organosedimentary deposits of benthic microbial communities: Palaios, v. 2, p. 241-254.
- Butlin, K. R., 1953, The bacterial sulphur cycle: Research, v. 6, p. 184-191.
- Calder, J. A., and Parker, P. L., 1973, Geochemical implications of induced changes in C¹³ fractionation by blue-green algae: Geochimica et Cosmochimica Acta, v. 37, p. 133-140.
- Caldwell, D. E., Kieft, T. L., and Brannan, D. K., 1984, Colonization of sulfide-oxygen interfaces on hot springs tufa by *Thermothrix thiopara*: Geomicrobiology Journal, v. 3, p. 181-200.
- Carr, N. G., and Whitton, B. A., eds., 1973, The Biology of Blue-Green Algae: Los Angeles, Blackwell Scientific Publications, 676p.

- Castenholz, R. W., 1973, Ecology of blue-green algae in hot springs: *in* Carr, N. G., and Whitton, B. A., eds., *The Biology of Blue-Green Algae*: Los Angeles, Blackwell Scientific Publications, p. 379-414.
- Cohen, Y., 1984, The Solar Lake cyanobacterial mats: Strategies of photosynthetic life under sulfide: *in* Cohen, Y., Castenholz, R. W., and Halvorson, H. O., eds., *Microbial Mats: Stromatolites*: New York, Alan R. Liss, Inc., p. 133-148.
- Cohen, Y., Castenholz, R. W., and Halvorson, H. O., eds., 1984, *Microbial Mats: Stromatolites*: New York, Alan R. Liss, Inc., 498p.
- Cohen, Y., Krumbein, W. E., and Shilo, M., 1977a, Solar Lake (Sinai). 2. Distribution of photosynthetic microorganisms and primary production: *Limnology and Oceanography*, v. 22, p. 609-620.
- Cohen, Y., Krumbein, W. E., and Shilo, M., 1977b, Solar Lake (Sinai). 3. Bacterial distribution and production: *Limnology and Oceanography*, v. 22, p. 621-634.
- Davis, R. A., 1968, Algal stromatolites composed of quartz sandstone: *Journal of Sedimentary Petrology*, v. 38, p. 953-955.
- Deelman, J. C., 1978, Experimental ooids and grapestones: Carbonate aggregates and their origin: *Journal of Sedimentary Petrology*, v. 48, p. 503-512.
- Degens, E. T., 1976, Molecular mechanisms on carbonate, phosphate, and silica deposition in the living cell: *Topics in Current Chemistry*, v. 64, p. 1-112.
- Doemel, W. N., and Brock, T. D., 1974, Bacterial stromatolites: Origin of laminations: *Science*, v. 184, p. 1083-1085.
- Dravis, J. J., 1983, Hardened subtidal stromatolites, Bahamas: *Science*, v. 219, p. 385-386.
- Dravis, J. J., and Yurewicz, D. A., 1985, Enhanced carbonate petrography using fluorescence microscopy: *Journal of Sedimentary Petrology*, v. 55, p. 795-804.
- Ehrlich, H. L., and Zapkin, M. A., 1985, Manganese-rich layers in calcareous deposits along the western shore of the Dead Sea may have a bacterial origin: *Geomicrobiology Journal*, v. 4, p. 207-221.

- Engel, A. E. J., Nagy, B., Nagy, L. A., Engel, C. G., Kremp, G., and Drew, C. M., 1968, Alga-like forms in Onverwacht Series, South Africa: Oldest recognized lifelike forms on earth: *Science*, v. 161, p. 1005-1008.
- Ennever, J., 1960, Intracellular calcification by oral filamentous organisms: *Journal of Periodontology*, v. 31, p. 304-307. (from Pautard, 1970)
- Ennever, J., and Takazoe, I., 1973, Bacterial calcification: *in* Zipkin, I., ed., *Biological Mineralization*: New York, John Wiley & Sons Inc., p. 629-648.
- Flugel, E., ed., 1977, *Fossil Algae Recent Results and Developments*: New York, Springer-Verlag, 375p.
- Friedman, G. M., 1978a, Importance of microorganisms in sedimentation: *in* Krumbein, W. E., ed., *Environmental Biogeochemistry and Geomicrobiology Volume 1: The Aquatic Environment*: Ann Arbor, Ann Arbor Science Publishers Inc., p. 323-326.
- Friedman, G. M., 1978b, "Solar Lake": A sea-marginal pond of the Red Sea (Gulf of Aqaba or Elat) in which algal mats generate carbonate particles and laminites: *in* Krumbein, W. E., ed., *Environmental Biogeochemistry and Geomicrobiology Volume 1: The Aquatic Environment*: Ann Arbor, Ann Arbor Science Publishers Inc., p. 227-235.
- Gallardo, V. A., 1977, Large benthic microbial communities in sulphide biota under Peru-Chile subsurface countercurrent: *Nature*, v. 268, p. 331-332.
- Garrett, P., 1970, Phanerozoic stromatolites: Noncompetitive ecologic restriction by grazing and burrowing animals: *Science*, v. 169, p. 171-173.
- Gebelein, C. D., 1969, Distribution, morphology, and accretion rate of recent algal stromatolites, Bermuda: *Journal of Sedimentary Petrology*, v. 39, p. 49-69.
- Gebelein, C. D., 1974, Biologic control of stromatolite microstructure: Implications for Precambrian time stratigraphy: *American Journal of Science*, v. 274, p. 575-598.

- Gebelein, C. D., 1976, Open marine subtidal and intertidal stromatolites (Florida, the Bahamas and Bermuda): *in* Walter, M. R., ed., *Stromatolites: Developments in Sedimentology 20*: Amsterdam, Elsevier, p. 381-388.
- Gerace, D. T., ed., 1983, *Field Guide to the Geology of San Salvador*, Third Edition: U. S. A., College Center of the Finger Lakes Bahamian Field Station, 172p.
- Gicklhorn, J., 1921, Morphologie et microchimie d'un nouveau groupe de bacteries pourpres: *Berichte der Deutschen Botanischen Gesellschaft*, v. 39, p. 312-319. (from Lalou, 1957a)
- Glover, E. D., 1961, Method of solution of calcareous material using the complexing agent, EDTA: *Journal of Sedimentary Petrology*, v. 31, p. 622-626.
- Golubic, S., 1983, Stromatolites, fossil and Recent: A case history: *in* Westbroek, P., and de Jong, E. W., eds., *Biomineralization and Biological Metal Accumulation*: Dordrecht, D. Reidel Publishing Company, p. 313-326. (from Pentecost and Bauld, 1988)
- Golubic, S., and Schneider, J., 1979, Carbonate dissolution: *in* Trudinger, P. A., and Swaine, D. J., eds., *Biogeochemical Cycling of Mineral-Forming Elements: Studies in Environmental Science, #3*: New York, Elsevier, p. 107-129.
- Gunatilaka, A., 1975, Some aspects of the biology and sedimentology of laminated algal mats from Mannar Lagoon, northwest Ceylon: *Sedimentary Geology*, v. 14, p. 275-300.
- Gunatilaka, A., Sahleh, A., and Al-Temeemi, A., 1985, Sulphate reduction and dolomitization in a Holocene Lagoon, Kuwait: *Society of Economic Paleontologists and Mineralogists Annual Midyear Meeting, II*, p. 38. (from Machel and Mountjoy 1986)
- Henisch, H. K., 1970, *Crystal Growth in Gels*: London, The Pennsylvania State University Press, 110p.
- Hirsch, P., 1977, Microbial mats in a hypersaline solar lake: Types, composition, and distribution: *in* Krumbein, W. E., ed., *Environmental Biogeochemistry and Geomicrobiology Volume 1: The Aquatic Environment*: Ann Arbor, Ann Arbor Science Publishers Inc., p. 189-201.

- Horodyski, R. J., 1977, *Lyngbya* mats at Laguna Mormona, Baja California, Mexico: Comparison with Proterozoic stromatolites: *Journal of Sedimentary Petrology*, v. 47, p. 1305-1320.
- Horodyski, R. J., and Vonder Haar, S. P., 1975, Recent calcareous stromatolites from Laguna Mormona (Baja California) Mexico: *Journal of Sedimentary Petrology*, v. 45, p. 894-906.
- Ingerson, E., 1962, Problems of the geochemistry of sedimentary carbonate rocks: *Geochimica et Cosmochimica Acta*, v. 26, p. 815-847.
- Jones, B., and Kahle, C. F., 1986, Dendritic calcite crystals formed by calcification of algal filaments in a vadose environment: *Journal of Sedimentary Petrology*, v. 56, p. 217-227.
- Jorgensen, B. B., 1977, Distribution of colorless sulfur bacteria (*Beggiatoa* spp.) in a costal marine sediment: *Marine Biology*, v. 41, p. 19-28.
- Jorgensen, B. B., 1982, Mineralization of organic matter in the sea bed - the role of sulphate-reduction: *Nature*, v. 296, p. 643-645.
- Jorgensen, B. B., and Cohen, Y., 1977, Solar Lake (Sinai). 5. The sulfur cycle of the benthic cyanobacterial mats: *Limnology and Oceanography*, v. 22, p. 657-666.
- Kalantarian, P., and Petrossian, A., 1932, Ueber ein neues kalkfallendes bakterium aus dem Sewan-See (Goktschasse): *Zentralblatt fur Bakteriologie, Parasitenkunde und Infektionskrankheiten, II, Abt.* 85, p. 431-436. (from Lalou, 1957a)
- Kazmierczak, J., and Degens, E. T., 1986, Calcium and the early eukaryotes: *Mitteilungen aus dem Geologisch-Palaontologischen Institut der Universitat Hamburg*, v. 61, p. 1-20.
- Kazmierczak, J., Ittekkot, V., and Degens, E. T., 1985, Biocalcification through time: Environmental challenge and cellular response: *Palaeontologische Zeitschrift*, v. 59, p. 15-33.
- Kellerman, K. F., and Smith, N. R., 1916, Halophylic and lime precipitating bacteria: *Zentralblatt fur Bakteriologie, Parasitenkunde und Infektionskrankheiten, II, Abt.* 45, 371. (from Pautard, 1970)

- Kieft, T. L., and Caldwell, D. E., 1984, Weathering of calcite, pyrite, and sulfur by *Thermothrix thiopara* in a thermal spring: *Geomicrobiology Journal*, v. 3, p. 201-216.
- Kitano, Y., and Hood, D. W., 1962, Calcium carbonate crystal forms formed from sea water by inorganic processes: *Journal of the Oceanographic Society of Japan*, v. 18, p. 35-39. (from Kitano et al., 1970)
- Kitano, Y., and Kanamori, N., 1966, Synthesis of magnesian calcite at low temperatures and pressures: *Geochemical Journal*, v. 1, p. 1-10.
- Kitano, Y., Park, K., and Hood, D. W., 1962, Pure aragonite synthesis: *Journal of Geophysical Research*, v. 67, p. 4873-4874.
- Krumbein, W. E., 1970, On the behaviour of pure cultures of marine microorganisms in sterilized and re-inoculated sediments: *Helgolander wiss. Meeresunters*, v. 20, p. 17-28. (from Krumbein, 1971)
- Krumbein, W. E., 1972, Role des microorganismes dans la genese, la degradation et la diagenese des roches en place: *Revue d'Ecologie et de Biologie du Sol*, v. 9, p. 283-319. (from Krumbein 1979a)
- Krumbein, W. E., 1973, Mikrobiologische Untersuchungen zur Fallung von Kalziumkarbonat aus Meerwasser: *in Biologische Anstalt Helgoland, Jahresbericht*, Hamburg, p. 50-54. (from Krumbein 1979a)
- Krumbein, W. E., and Giele, C., 1979, Calcification in a coccoid cyanobacterium associated with the formation of desert stromatolites: *Sedimentology*, v. 26, p. 593-604.
- Lazaroff, N., Melanson, L., Lewis, E., Santoro, N., and Poeschel, C., 1985, Scanning electron microscopy and infrared spectroscopy of iron sediments formed by *Thiobacillus ferrooxidans*: *Geomicrobiology Journal*, v. 4, p. 231-246.
- Leadbeater, B. S. C., and Riding, R., eds., 1986, *Biom mineralization in Lower Plants and Animals*: Oxford, Clarendon Press, 401p.
- Lucas, J., and Prevot, L., 1985, The synthesis of apatite by bacterial activity: Mechanism: *Sci. Geol., Mem.*, v. 77, p. 83-92.

- MacLeod, R. A., Onofrey, E., and Norris, M. E., 1954, Nutrition and metabolism of marine bacteria 1. Survey of nutritional requirements: *Journal of Bacteriology*, v. 68, p. 680-686.
- Mitterer, R. M., 1971, Biogeochemistry of aragonite mud and oolites: *Geochimica et Cosmochimica Acta*, v. 36, p. 1407-1422.
- Mitterer, R. M., and Cunningham, R. Jr., 1985, The interaction of natural organic matter with grain surfaces: Implications for calcium carbonate precipitation: *in* Schneidermann, N., and Harris, P. M., eds., *Carbonate Cements: Tulsa, Society of Economic Paleontologists and Mineralogists Special Publication #36*, p. 17- 31.
- Molisch, H., 1925, Ueber Kalkbakterien and andere kalkallende Pilze: *Zentralblatt fur Bakteriologie, Parasitenkunde und Infektionskrankheiten*, II, Abt. 65, p. 130-139. (from Gee, 1932)
- Monty, C. L. V., 1965, Recent algal stromatolites in the Windward Lagoon, Andros Island, Bahamas: *Ann. Soc. Geologique de Belgique*, T. 88, p. 269-276.
- Moriarty, D. J. W., 1983, Bacterial biomass and productivity in sediments, stromatolites, and water of Hamelin Pool, Shark Bay, Western Australia: *Geomicrobiology Journal*, v. 3, p. 121-133.
- Mucci, A., and Morse, J. W., 1984, The incorporation of Mg^{2+} and Sr^{2+} into calcite overgrowths: Influences of growth rate and solution composition: *Geochimica et Cosmochimica Acta*, v. 47, p. 217-233.
- Murray, J., and Irvine, R., 1889, On coral reefs and other carbonate of lime formation in modern seas: *Proceedings of the Royal Society of Edinburgh*, v. 17, p. 79-109. (from Morita, 1980)
- Pentecost, A., 1985, Association of cyanobacteria with tufa deposits: Identity, enumeration, and nature of the sheath material revealed by histochemistry: *Geomicrobiology Journal*, v. 4, p. 285-298.
- Pentecost, A., 1987, Growth and calcification of the freshwater cyanobacterium *Rivularia haematites*: *Proceedings of the Royal Society of London, Series B*, v. 232, p. 125-136.
- Pentecost, A., 1988, Calcification processes in algae and cyanobacteria: *in* Riding, ed., *4th International Symposium on Fossil Algae* (in press). (from Pentecost and Bauld, 1988)

- Pochon, J., Chalvignac, M. A., and Krumbein, W. E., 1964, Recherches biologiques sur le mondmilch: Comptes Rendus de l'Academie des Sciences, v. 258, p. 5113-5115.
- Postgate, J. R., 1966, Media for sulfur bacteria: Laboratory Practice, v. 15, p. 1239-1244.
- Presley, B. J., and Kaplan, I. R., 1968, Changes in dissolved sulfate, calcium and carbonate from interstitial water of near-shore sediments: Geochimica et Cosmochimica Acta, v. 32, p. 1037-1048.
- Pringsheim, E. G., 1949, Iron bacteria: Cambridge Philosophical Society Biological Reviews, v. 24, p. 200-245.
- Reimers, C. E., 1982, Organic matter in anoxic sediments off Central Peru: Relations of porosity, microbial decomposition and deformation properties: Marine Geology, v. 46, p. 175-197.
- Riding, R., 1977, Skeletal stromatolites: *in* Flugel, E., ed., Fossil Algae: New York, Springer-Verlag, p. 57-60.
- Roberts, H. H., and Whelan, T. III, 1975, Methane-derived carbonate cements in barrier and beach sands of a subtropical delta complex: Geochimica et Cosmochimica Acta, v. 39, p. 1085-1089.
- Roemer, R., and Schwartz, W., 1965, (no title listed): Zeitschrift fur Allgemeine Mikrobiologie, v. 5, p. 122-135. (from Ehrlich, 1981)
- Schneidermann, N., and Harris, P. M., eds., 1985, Carbonate Cements: Tulsa, Society of Economic Paleontologists and Mineralogists Special Publication #36, 379p.
- Sieburth, J. McNeill, 1979, Sea Microbes: New York, Oxford University Press Inc., 491p.
- Simkiss, K., 1976, Cellular aspects of calcification: *in* Watabe, N., and Wilbur, K. M., eds., The Mechanisms of Mineralization in the Invertebrates and Plants: Columbia, South Carolina, University of South Carolina Press, p. 1-31.
- Smith, N. R., 1926, Report on bacterial examination of "chalky mud" and sea-water from the Bahamas Bank: Carnegie Institution of Washington Yearbook, v. 23, p. 67-72. (from Pautard, 1970)

- Sorensen, L. O., and Conover, J. T., 1962, Algal mat communities of *Lyngbya confervoides* (C. Agardh) Gomont: Publications of the Institute of Marine Science, University of Texas, v. 8, p. 61-74.
- Stolz, J. F., 1984, Fine structure of the stratified microbial community at Laguna Figueroa, Baja California, Mexico: II. Transmission electron microscopy as a diagenetic tool in studying microbial communities *in situ*: in Cohen, Y., Castenholtz, R. W., and Halvorson, H. O., eds., Microbial Mats: Stromatolites: New York, Alan R. Liss, Inc., p. 23-38.
- Takahashi, M., and Ichimura, S., 1970, Photosynthetic properties and growth of photosynthetic sulfur bacteria in lakes: Limnology and Oceanography, v. 15, p. 929-944.
- Thode, H. G., Wanless, R. K., and Wallouch, R., 1954, The origin of native sulfur deposits from isotope fractionation studies: Geochimica et Cosmochimica Acta, v. 5, p. 286-298.
- Thomas, R. C., 1978, Ion-Sensitive Intracellular Microelectrodes, How to Make and Use Them: London, Academic Press, Inc., 110p.
- Trichet, J., 1972, Etude du mecanisme de la nucleation du carbonate de calcium dans les depots dus a des Cyanophyces (Polynesie Francaise): Comptes Rendus Congress Geologique Internationale, Montreal, Sect. 7, p. 631-638. (from Krumbein 1979a)
- Trudinger, P. A., and Swaine, D. J. eds., 1979, Biogeochemical Cycling of Mineral-Forming Elements: Studies in Environmental Science #3: New York, Elsevier, 612p.
- Venetskaya, S. L., and Gerasimenko, L. M., 1988, Electron-microscopic study of microorganisms in a halophilic cyanobacterial community: Microbiology, v. 57, p. 377-383.
- Verkhovtseva, N. V., Glebova, I. N., and Morozov, V. V., 1988, Accumulation of iron by *Seliberia stellata* under various conditions: Microbiology, v. 57, p. 20-24.
- Von der Borch, C. C., Bolton, B., and Warren, J. K., 1977, Environmental setting and microstructure of subfossil lithified stromatolites associated with evaporites, Marion Lake, South Australia: Sedimentology, v. 24, p. 693-708.

- Walter, M. R., 1976, Hot-spring sediments in Yellowstone National Park: *in* Walter, M. R., ed., *Stromatolites: Developments in Sedimentology 20*: Amsterdam, Elsevier, p. 489-498.
- Walter, M. R., Bauld, J., and Brock, T. D., 1972, Siliceous algal and bacterial stromatolites in hot springs and geyser effluents of Yellowstone National Park: *Science*, v. 178, p. 402-405.
- Ward, D. M., Beck, E., Revesbeck, N. P., Sandbeck, K. A., and Winfrey, M. R., 1984, Decomposition of hot spring microbial mats: *in* Cohen, Y., Castenholtz, R. W., and Halvorson, H. O., eds., *Microbial Mats: Stromatolites*: New York, Alan R. Liss, Inc., p. 191-214.
- Weirich, G., and Schweisfurth, R., 1985, Extraction and culture of microorganisms from rock: *Geomicrobiology Journal*, v. 4, p. 1-20.
- Whitlatch, R. B., and Johnson, R. G., 1974, Methods for staining organic matter in marine sediments: *Journal of Sedimentary Petrology*, v. 44, p. 1310-1312.
- Williams, L. A., and Reimers, C., 1983, Role of bacterial mats in oxygen-deficient marine basins and costal upwelling regimes: Preliminary report: *Geology*, v. 11, p. 267-269.
- Winsborough, B. M., and Golubic, S., 1987, The role of diatoms in stromatolite growth: Two examples from modern freshwater settings: *Journal of Phycology*, v. 23, p. 195-201.
- Wright, V. P., and Wright, J. M., 1985, A stromatolite built by a phormidium-like alga from the Lower Carboniferous of South Wales: *in* Toomey, D. F., and Nitecki, M. H., eds., *Paleoalgology, Contemporary Research and Applications*: New York, Springer-Verlag, p. 40-54.

END

**DATE
FILMED**

10/01/192

