

Fermi National Accelerator Laboratory

FERMILAB-Conf-94/378-E

CDF

The Tevatron Hadron Collider: A Short History

Alvin V. Tollestrup

*Fermi National Accelerator Laboratory
P.O. Box 500, Batavia, Illinois 60510*

November 1994

Published Proceedings *International Conference on the History of Original Ideas and Basic Discoveries in Particle Physics*, Ettore Majorana Centre for Scientific Culture, Erice, Sicily, Italy, July 29-August 4, 1994

Disclaimer

This report was prepared as an account of work sponsored by an agency of the United States Government. Neither the United States Government nor any agency thereof, nor any of their employees, makes any warranty, express or implied, or assumes any legal liability or responsibility for the accuracy, completeness, or usefulness of any information, apparatus, product, or process disclosed, or represents that its use would not infringe privately owned rights. Reference herein to any specific commercial product, process, or service by trade name, trademark, manufacturer, or otherwise, does not necessarily constitute or imply its endorsement, recommendation, or favoring by the United States Government or any agency thereof. The views and opinions of authors expressed herein do not necessarily state or reflect those of the United States Government or any agency thereof.

THE TEVATRON HADRON COLLIDER A SHORT HISTORY

Alvin V. Tollestrup
Fermilab MS 318
Box 500
Batavia, IL 60510

INTRODUCTION

The subject of this presentation was intended to cover the history of hadron colliders. However this broad topic is probably better left to historians. I will cover a much smaller portion of this subject and specialize my subject to the history of the Tevatron. As we will see, the Tevatron project is tightly entwined with the progress in collider technology. It occupies a unique place among accelerators in that it was the first to make use of superconducting magnets and indeed the basic design now forms a template for all machines using this technology. It was spawned in an incredibly productive era when new ideas were being generated almost monthly and it has matured into our highest energy collider complete with two large detectors that provide the major facility in the US for probing high Pt physics for the coming decade.

As a reminder of how far we have come in the last thirty years, I have included a picture, Figure 1, of the first collider which was called AdA at Frascati.

Figure 1. Photograph of the AdA electron storage ring at Frascati about 1961-1962.

It was given to me on a visit to that laboratory by the wife of B. Touschek. It is shown located on rails outside the synchrotron, and injection was by accomplished by shinning the bremsstrahlung beam first on one side where pair produced electrons were captured from an internal target, and then repeating the same operation on the opposite side of the magnet by physically moving it so that the bremsstrahlung beam hit a target on the opposite side of the machine and positrons were captured! It was easy to calibrate the number of electrons circulating because occasionally one would hit a gas atom and be scattered out of the beam causing a step decrease in the synchrotron light being observed by a photomultiplier. Later the intensity increased to more than 10^7 stored electrons. Such was the fore runner of all the beautiful physics that has come from the electron colliders!

HISTORY

FFAG

I would like to go back to the start of the 300 GEV machines. A series of useful dates is given in Table 1 to help set the stage for the rest of this talk.

@Table = Table 1. Some important dates.

YEAR	BNL	CERN	FNAL	OUTSIDE WORLD
1952	Strong focusing invented. Cosmotron 3 GeV			
1956				LBL Bevatron 6 GeV
1959		PS 24 GeV		1959 FFAG workshop at MURA
1960	AGS 33 GeV			

1961				WAG 300 GeV design study.
1963				Ramsey Panel sets priorities for US.
1968			FNAL starts	
1971		ISR comes on line. the first hadron storage ring		
1972	ISABELLE design study. SC magnets		Main Ring 400 GeV	
1974			SC magnet program starts at FNAL	Budker demonstrates electron cooling
1975		Stochastic cooling demonstrated at ISR		
1976		SPS comes on line	Colliding beam workshop at FNAL	
1981		SPPbarS starts		
1982			TEVATRON comes on line	
1986			TEVATRON Pbar-P 1.8 Tev on-line	

In the period around 1960, there was a proposal developed by MURA (Midwest Universities Research Association) for a large machine that would be built in the midwest region of the US. This group was incredibly productive and inventive and many ideas for stacking beams and RF manipulations came from this group. The FFAG was a fixed field alternating gradient machine and is shown in Fig. 2.

Figure 2. Drawings from MURA. The top drawing is a layout of the tunnel and magnet. The lower is a cross section

through the magnet. Injection was at the inner radius and the final beam position was at the outside edge. The sectors alternated in the direction of the field and protons could travel in either direction around the machine. Note the scale and the size of the magnet!

The magnet was composed of spiral sectors with alternating field direction in which the average radius of the particle orbit changed during acceleration. This required enormous magnets with large aperture and the orbits had the unique property that particles of a given energy could circulate in either direction! The two sets of orbits crossed at a number of points around the machine. The two beams each had an energy of 12 GEV and thus the machine could be used either as a collider at 24 GEV in the CM system to study PP collisions or as a 12 GEV high intensity proton accelerator. Some of the properties of the design are shown in Table 2.

TABLE 2. Some properties of the FFAG machine.

R_{max}	88.75 m. Max. good field radius
R_{min}	85.33 m. Min. good field radius
V_{inj}	30 cm. Vertical aperture at injection
V_{min}	15 cm. Vertical aperture at Rmax
Mag. mass	24,100 tons Total magnet weight
P_{mag}	47.2 MW Total magnet power
E_{inj}	200 Mev injection energy
E_{final}	12.5 GeV final energy ...each beam. 25 GeV CM.
RF	2 MW total

In 1959 the MURA group hosted a workshop at Madison to study the properties of the machine and the physics program that it could support. As part of this study, a group was set up under Matt Sands to consider a 300 GEV accelerator design. This energy matched the 24 GEV CM energy of the FFAG. It is my belief that our hosts thought that such a machine would turn out to be impossibly complicated and that physics with it would be very difficult.

Sands accepted the challenge and a small number of us blocked out the first rough design of a machine. Sands was already acquainted with the idea of using cascade machines, and so there was a 50 MEV linac injecting in to a low energy booster which finally injected into the large ring. There was also a subgroup that was considering possible physics experiments.

An initial concern was that at such a high energy, all of the particles would go into a small forward cone and would be very hard to measure. However, it soon became apparent that this was actually an advantage and that unstable particles would have all of their decay particles contained within such a cone where they could be easily identified and measured.

When we returned to Caltech, there was much discussion and excitement about actually building such a machine. Not long after, the PS came on-line at CERN. It had been anticipated that there would be very high fluxes of pions and kaons in the forward direction and this was quickly confirmed. This increased our excitement with respect to a higher energy ring, and we proceeded to put together a serious study. We called ourselves WAG for Western Accelerator Group. LBL did not join, but the rest of the universities in Southern California did. We invited H. Snyder, E. Courant, the Blewetts and got to work. By 1961, we had blocked out a complete preliminary design. This work was documented in a series of WAG reports that can now be found in the FNAL History Archives.

The result of this study was to start a great competition between the various areas of the country. LBL obviously wanted to continue their push for ever higher energy. The FFAG was still on the books. BNL, where the AGS had just come on line and was making its glorious discoveries, was obviously concerned about its long range future. Caltech had submitted a request to the AEC for funding a serious design for a 300 GEV machine but we never received support for further work.

Apparently this type of study was to be done by the "professionals" at the national laboratories. Some decisions had to be taken and it was against this background that the RAMSEY PANEL was convened to consider the future course for the US program. The result was that LBL should proceed with a large machine, that BNL should consider 1 TEV storage rings, and that the FFAG was last on the list of priorities, which essentially condemned it to oblivion.

FERMILAB

EARLY HISTORY

During the next 5 years, the 300 GEV machine design matured. CERN had developed a coherent long range program encompassing the ISR and the SPS and as a result became an active contributor as well as competitor. Finally the political hurdles were cleared in the US and Fermilab was started in 1968. The first very early workshops considered various possibilities for colliding beams. Indeed Wilson had issued an edict that the space under the Main Ring was to be kept clear for a second machine in the future! In 1971, the ISR started working at CERN and colliding hadron beams became a reality. Even more important, the ISR was incredibly productive in advancing accelerator theory, and as we shall see the invention of stochastic cooling by Van der Meer using this machine as a test bed was crucial for the next step!

In this period several additional important things happened. In 1972, BNL proposed ISABELLE, a collider with superconducting magnets. There had also been pioneering work in England on magnets of this type for use in the SPS, but the approach was abandoned after some seminal work and the choice went in favor of conventional iron magnets. The Main Ring came on at Fermilab in 1972, and by 1974 Wilson was already thinking of the next step

When the Main Ring started working, the construction project was declared finished but there was some \$20 M left over and Wilson was not one to let money go to waste. He proposed to divert these funds to the construction of a higher energy ring using the new superconducting magnet technology. The rationale for it was that it would double the energy and also due to the low energy loss in the magnets would actually save power which at that time was becoming a major expense for accelerator laboratories.

In the spring of 1975, I left Caltech to spend a nine month sabbatical leave at Fermilab. In the previous year, some 10 foot long model magnets using a monolithic super conductor had been built, tested, and failed. An experimental extraction line from the main ring had been constructed and was in the process of being tested. The proposed position for the new ring of magnets at this time was hanging from the top of the concrete arch enclosing the tunnel in order to give easy access for

installation and servicing. Finally, due to the failure of the magnets using monolithic conductor, an ambitious program of building model magnets only one foot long had been started. Even at this early stage, Wilson had received several informal proposals for bringing the beams in the two machines into collision. He asked me to run a workshop on colliding beam possibilities, and I organized it for early 1976.

Some of the proposals were rather humorous in retrospect. One in particular from a couple of famous physicists proposed operating the Doubler (remember it was located on the ceiling) at 10 GeV, swooping the beam down and colliding it with the Main Ring which was supposed to store beam at 400 GeV. However, humor aside, this workshop was crucial for shaping the future design of the FNAL machines. It became obvious that the Doubler and Main Ring should be as close together as possible in order to be able to transfer high energy beams between them or to bring the separate beams into collisions. Wilson immediately suggested installing the Doubler below the Main Ring, and was pleasantly surprised to find that this space was completely clear. He had forgotten that he issued an edict when the Main Ring was installed that the area under the magnets was to be kept clear for a future ring! From then on, the concept that the new ring would be part of a collider complex was firmly in place. Figure 3 shows a photograph of a collection of Design Report Covers from the earliest proposals.

Figure 3. Design Report Covers. The bottom is front and back of a June 1976 report. The top right is May 1977, and the top left is Feb. 1980.

The workshop stimulated and focused a large effort to define the requirements for a successful collider configuration. I proposed, and with the accelerator division, carried out the first storage experiments in a large accelerator ring in mid 1976. A photo of the first store in the Main Ring at 200 GeV is shown in Figure 4.

Figure 4. First store of protons in the FNAL Main Ring. Note the short lifetime!

It also became clear that many problems would have to be solved if beam was going to be stored in the Main Ring for long periods of time. The vacuum was not good enough and the peak energy would be limited to about 200 GeV by magnet heating in the DC mode. In order to focus attention on the special requirements that colliding beam experiments would place on the configuration of the machines, I started a small group whose goal was to prepare a proposal for a PP experiment which would collide the protons from the 200 GeV MR with those of the 1000 GeV Doubler beam. This group carried out many of the early studies on beam storage, backgrounds, low beta sections and detector design.

A second result of the workshop came about from work that had been going on at CERN and Novosibirsk. In 1974 Budker demonstrated that a beam of protons could be cooled through its interaction with a co-moving equal velocity electron beam. In 1975, Van der Meer had demonstrated stochastic cooling of the beam in the ISR. This led to a suggestion by Peter McIntyre that antiprotons could be cooled and used for collisions with protons in a single machine. This ultimately resulted in a proposal from Rubbia, Cline and McIntyre to build a proton antiproton experiment either at FNAL or CERN. There was intense competition between the groups. Finally, on Nov. 11, 1978, there was a famous "shoot out" at FNAL in which Lederman decided that the first order of business at FNAL had to be finishing the Doubler, but then the next step would be to build a proton-antiproton collider which would realize the full potential of the Tevatron to achieve 2 TeV in the CM system. The FNAL group ultimately became CDF, and in the meantime CERN opted for immediately pursuing the antiproton facility that resulted in the spectacular success of ACOL, UA1, and UA2. We will return later to this subject, after discussing the development of the Doubler.

ACCELERATOR

SUPERCONDUCTING CABLE

The first problem that had to be solved was to secure a reproducible supply of conductor. A large quantity of Niobium-Titanium alloy was purchased and fabricated into the shape of rods about 3 mm in diameter and 60 cm long. Wire was manufactured from these by imbedding them in a hexagonal shaped rod of pure copper with a 3 mm hole in it. These were then packed in a close packed array inside a 25 cm diameter copper pipe, end pieces welded on and the whole array drawn to produce a single strand of wire about 0.6 mm in diameter with some 2000 individual strands of superconductor less than 10 microns in diameter embedded in pure copper. At the time, there was no single company with the ability to process the large amount of superconductor that would be required for the Doubler. Kits of NbTi rods and the copper jackets were sent

to a number of different companies. The specific combination of drawing and heat treatment determined the ultimate current carrying capacity of the strand. These proprietary processes belonged to the individual companies and were carefully guarded secrets and there was great competition to produce the best cable.

The cable design chosen had been worked out at the RHEL for possible use at CERN on the SPS. The Tevatron cable was a variation on this design and is shown in Figure 5.

Figure 5. The complete Tevatron cable is shown and also a single strand that has been etched with acid to remove the copper matrix. The individual NbTi filaments can be seen. The cable is wrapped in Kapton film for turn to turn insulation. This wrapping also forms a cocoon that protects the wire from exposure heat to generated by any frictional motion of the coil.

Before this work, all of the large magnets were for bubble chambers and had employed a completely stabilized cable. There are many considerations that go into the design of the cable, but some appreciation of the problems can be easily derived. If the superconductor ever goes normal, its resistance becomes comparable to iron, and hence the current is immediately driven into the surrounding copper matrix. If it weren't for the copper, the joule heating would melt the conductor in milliseconds! In the case of bubble chambers, space is not at a premium, and a large amount of stabilizer can be placed around the superconductor. In fact if there is enough, the cooling by the liquid Helium can be sufficient to lower the temperature again to the point where the superconductivity returns. This is a cryostable conductor. However in the case of accelerator magnets, space is at a premium and large current densities must be achieved if one is to reach high fields. In this case, if the superconductor goes normal, there is not enough copper to carry the current indefinitely. The amount of copper used is just sufficient to limit the heating that takes place while the sensing circuits detect that there is a malfunction and take appropriate action to save the magnet from destruction. The time is of the order of one second.

QUENCH PROTECTION

We developed two ways to protect the magnets from the above catastrophic failure. The first simply used an SCR switch to dump the energy from the magnet (of the order of .5 megajoules for a full scale magnet) into a resistor. This was used only on test stands for single magnets, and was not a suitable solution for a magnet in a machine. However it was a crucial step in the magnet R&D program because it allowed non-destructive testing of magnets. Consider next the case of a magnet in the machine in which some of the superconductor has gone normal. An electronic monitoring circuit can sense this and short the terminals of the magnet. The quench zone will spread because the heat generated will be conducted along the cable and cause more of it to go normal. However such a quench zone propagates rather slowly...between 1 and 10 meter/sec. Thus all of the energy stored in the magnet will be deposited locally in the cable. If this zone is too small, the temperature will become high enough to damage either the insulation or cable. However, if a large region of the magnet could be turned normal, the heat capacity of the cable would be sufficient to limit the temperature rise to safe values. The solution suggested by R. Steining and R. Flora involved firing a heater circuit that turned a large section of the magnet normal. This was the solution adopted for the Doubler. A variation of this solution is to eliminate the heaters and design the magnet so that the quench zone propagates at a high enough speed to bring a large amount of the winding to the normal state.

MAGNET FIELD QUALITY

The field inside a two dimensional region is completely determined by the current distribution on the boundary, and if one could achieve a sinusoidal distribution, the field would be uniform. The magnets of the doubler and all other machines approximate this distribution using blocks of turns to simulate a current shell. Note that single current shell cut at 60 degrees will not have any sextupole moment. Furthermore, if it is accurately symmetrical left and right as well as up and down, the quadrupole, octupole,.... will all vanish. With two current shells, one has another set of angles to adjust, and the decapole in addition can be made to vanish. In the case of the Doubler, this was considered to be sufficient to produce an accelerator quality field over 2/3 of the diameter of the coil which was 7.5 cm. The SSC magnet design was pushing the technology much harder and the good field region occupied a greater portion of the magnet aperture. The design achieved this goal by using more blocks of conductor in the coil design. However, in the case of the Doubler, the primary challenge was to develop factory production methods that were capable of maintaining the tolerances of the order of ten microns on

the coil dimensions and hence the design was kept as simple as possible. Figure 6 shows the collared coil of the Tevatron and of an early 4 cm SSC coil. The current blocks are clearly seen.

Figure 6. A piece of a Tevatron collared coil is shown on the left and on the right is an early 4 cm version of the SSC magnet. The larger number of current blocks in the SSC magnet allowed the good field region to be a greater fraction of the inner radius of the coil. The interlocking collar laminations can also be clearly seen.

FORCES

The forces within the magnet are very large at full field. In the doubler a typical force on a single conductor is of the order of 16,000 N/meter and in the SSC magnets several times larger than this. The conductor must be kept from moving both because motion would affect the field quality and any inelastic motion would generate heat and cause a quench to occur. It is easy to see how sensitive the magnets are to an external source of heat. Figure 7 attempts to show some of the relative quantities.

Figure 7. This figure is an energy content diagram. The line shows the enthalpy of the cable. The heat of vaporization of the entrapped Helium is 45 mj/cm of cable, but its heat capacity is much smaller and it will absorb only 0.65 mj for a ΔT of 0.1 °K. The elastic energy stored in the coil matrix is about 4 mj/cm of cable. A ΔT of .05 °K will quench a magnet. A quench releases 500 Kjoules!

The vertical scale gives the enthalpy of the various elements within the winding. The line is the enthalpy of the conductor itself. It is very small at the operating point...of the order of 0.7 mj/cm of cable and a slope of 0.2 mj/deg K. The elastic energy stored in this same volume is about 10 times larger, and the heat of vaporization of the Helium entrapped in the cable strands is about 45 mJ/cm. Two things stand out and dominate the design of all magnet systems. The first is that energy deposits of the order of millijoules in a centimeter of conductor can cause a magnet to quench. There are many sources capable of supplying this small quantity of energy such as inelastic motion of the conductors or stray beam striking the magnet. The second interesting point is that the main heat sink is the entrapped Helium and this is what stabilizes the magnet.

When a newly constructed magnet is first cooled down and excited it will frequently quench before reaching the theoretical predicted field. The second and third times it will reach a higher field and will asymptotically approach the theoretical limit. This phenomena is called "training" and has been traced to inelastic motion of the conductor. The first quench relieves some of the strain and the conductor slips into a more stable configuration so that the next cycle carries it to a higher field. This is clearly unacceptable behavior for an accelerator magnet and the solution to the problem was achieved by keeping the mechanically applied forces from the support structure always greater than the magnet forces during excitation. Thus when the magnets are constructed a large compressive force is built into the structure. Maintaining this compression as the magnet is cooled is a challenge because as the coil in general has a larger thermal expansion coefficient than the stainless steel support structure. This is compensated for by increasing the forces built into the structure at room temperature during fabrication but there is a limit to how far this can go without crushing the insulation around the cable and causing turn to turn shorts in the magnet. A major uncertainty was whether or not the information that was obtained from the one foot magnet program would apply to full size magnets. The small magnets could be built and tested in a matter of weeks and did not require large quantities of precious cable. They were a great vehicle for developing the new technology. Fortunately the methods developed for constructing good small magnets did indeed apply to their bigger brothers and the nightmare that thirty foot magnets would train 30 times worse than one foot magnets never materialized!

COLLARS

The two problems mentioned above of containing the large forces and maintaining the accuracy of the coil were solved by the invention of "collars". I developed the idea over a Christmas vacation, but did not understand how they could be fabricated. However this was quickly taken care of by the clever engineers, and the solution has far reaching applications. The magnet coil needs to be enclosed in a very strong encompassing steel frame. This is provided by stamping pieces out of stainless sheet stock and placing them around the coils. An inside portion of the stamping has the dimensions of the finished coil but has U shaped fingers that extend past the semicircular portion. These legs overlap the adjacent piece and the whole structure can be slipped over the coil. The composite is placed in a large press, squeezed together and the

overlapping edges of the stainless steel pieces welded along the length of the magnet. The stainless steel conducts heat poorly so that the welds can be made without damaging the coil insulation. The stampings can be easily made to a precision of several microns which helps to solve the problem of maintaining an accurate and reproducible coil cross section. Some stampings are shown in Figure 9.

There was an additional fallout from this work. In order to fabricate the coils, it is necessary to have large presses into which the coils fit after winding. Their insulation is impregnated with epoxy resin which must be heated to cure it. During this process, the coil must be held in a very accurate form and a high pressure applied to fix its final size. As the coils are 5 to 10 meters long, it is very difficult to machine such accurate forms from solid material. However the stamping technology is ideal for forming pieces with a very accurate local profile. Stacking these pieces together on a precision flat bed and welding them in place is an easy and reproducible way to generate this tooling. Furthermore it can be replicated easily. Figure 8 shows some of this tooling.

Figure 8. (a) Some of the laminated tooling stampings used for the Tevatron. These pieces were used for forming and curing the coils. The holes carried pipes with hot liquid to cure the epoxy. The laminations are aligned on a precision flat ground steel bed and welded together to give the require cross section. (b) The lower photo shows a completed piece of laminated tooling for forming the coils.

THE FACTORY CONCEPT

From the start, Wilson had the concept that the magnets would have to be assembled in house with as much help as possible from outside vendors supplying components. There were several reasons for doing this. It was not clear what problems would be encountered in making some million welds that had to be vacuum tight after suffering the strain of cool down. Holes too tiny to detect with conventional technology could still be a disaster when immersed in liquid helium. All the gasses except helium are cryo-pumped. However, even helium sticks to a 4.5 deg K. surface with a very small binding energy and can be easily knocked off with stray beam...which makes for an unstable accelerator, but also makes He leaks in a cold magnet very hard to find and fix.

The second reason for constructing a factory was dictated by the tight dimensional tolerances that had to be maintained during magnet assembly. The successful construction of a magnet by highly skilled craftsmen was no proof that a 1000 of them could be built. Thus the "factory" became our research laboratory. It occurred to me that the factory could also be viewed as a box into which raw materials were fed and finished magnets appeared in the output queue. Immediately the question of quality control arises and this is provided by measuring the finished magnets. The key element in this process was to develop a method to measure the field of a finished coil at room temperature. If the measurement must wait until the coil is in a cryostat and cooled down it is too late...there is too much delay (too many bad magnets could have been produced) and much effort has gone into the complete assembly.

Since the field inside a cylindrical region is completely determined by the current distribution on a cylinder, it is possible to relate errors in the field to dimensional errors in the coil. The challenge was to make measurements of the magnet field of the coil at room temperature to an accuracy of a few parts in ten thousand. The field is small because the coil can only carry 10 amps or so at room temperature due to its high resistance. We succeeded in doing this with R. Peters and M. Kuchnir, although this technology was later vastly improved at BNL for use on the SSC magnets. Thus we were able to close the feedback loop around the factory. If the multipole moments changed, it indicated some critical dimension was changing. The error could then be used to correct the production process in the factory. There is also an important corollary, which is that the magnet field was directly monitored during assembly which moderated the need to achieve absolute geometrical accuracy. The output of the factory is directly related to what the beam will see!

CRYOGENICS

The cryogenics also required a large extrapolation of existing technology and had a direct impact on the basic design of the magnets. Isabelle was designed with the iron flux return yoke also performing the duty of supporting the coil. This has the advantage of having plenty of iron to carry the forces. However there were two disadvantages that ruled it out for the Doubler. The first was the concern that available liquefaction plants would take much too long to cool the coil plus the large mass of the iron return yoke down to liquid helium temperatures. This concern was exacerbated by the fact that superconducting magnets were entirely new and it was uncertain how often we would have to warm up to make repairs. The second fact was there wasn't room for the gigantic cryostat and even more important (I believe) it violated Wilson's aesthetic senses. Thus from the start, the magnet had its cryostat contained within a warm return yoke. This also meant

that the iron was operated in its linear region...an important consideration since the dipoles and quads were in series and had to track each other over a wide region of magnet fields. The various components of the cryostat are shown in Figure 10a.

The cryogenic problems were all solved and some of them in a rather elegant manner... in particular the method used for cooling the coils. Liquid helium under some pressure flows around the beam tube and coils through 16 magnets and then goes through a JT valve and is returned in a pipe concentric with that containing the coil to the refrigerator. Thus there is single phase helium around the coil and two phase helium in very good thermal contact surrounding it. As the two phase flows through the string it changes more and more to the gas phase and absorbs heat from the magnet as it goes. This provides essentially a constant temperature bath for the magnet coils.

The cryogenic effort was heavily dependent on the Fermilab staff that had constructed the 15 foot bubble chamber. They not only supplied the cryogenic know how, but also formed the nucleus for training the large crew of physicists and technicians that ultimately brought the doubler on line. A large central helium plant was built. The technique of distributing liquid helium and nitrogen around a 6 kilometer ring was solved. Twenty four satellite refrigerators were designed and build, and last but not least the whole system brought under computer control. The successful operation of the Tevatron cryogenic system supplied the basis for the design of the much larger systems needed in the SSC and LHC.

THE MACHINE

The machine design had been proceeding at a low level during the period when we were solving the magnet problems. However there were severe problems with obtaining sufficient funding for the new machine, and Wilson resigned 1978 in an attempt to increase the support. Shortly after, Lederman became director in 1979, and a review of the program was undertaken and a commitment to support a realistic construction schedule was obtained from the DOE. With the promise of money and support, the machine design was finalized in May 1979, and the installation under the direction of Helen Edward's and Rich Orr began in earnest. Although we still did not have approval for colliding beams, the machine design included all of the necessary features for later use in this mode. The construction and installation effort occupied a major part of the time of almost everyone at FNAL for over two years and finally on July 3, 1983, the machine first reached 512 GEV, followed by operation at 900 GEV on Feb. 16, 1984, almost 10 years after the initial work started, and six months after the discovery of the Z at CERN.

SUBSEQUENT DEVELOPMENTS

The successful operation of the Tevatron had an enormous impact on subsequent machine development. Successful magnets based on the Tevatron design have been constructed with apertures ranging from 4 cm to over 15 cm. Figure 9 shows a collection of the collars for the coiled of some of these magnets. Note the obvious relationship of these to each other.

Figure 9. A collection of collar laminations for some SC magnets that have been successfully constructed using the Tevatron technology. The top is one lamination from a magnet built at KEK with an aperture of 15 cm. The one in the center of the group is from the Tevatron, and the one to the left is from UNK, aperture 9 cm. The two on the left are from the SSC 4 cm and 5 cm magnets respectively. The lower left is from HERA.

Although the magnet coil and collars remains essentially the same, there have been numerous developments. One of the most important has been the improved processing of the superconductor so that the attainable current density is almost twice that used in the Tevatron magnets. The second big advance came from the concept of using cold iron return yoke. This was pioneered at BNL for ISABELLE, and successfully implemented at HERA using collared coils and is now "standard design". The iron is separated from contact with the coil by the thickness of the collars, and although it goes into saturation, it adds considerably to the magnitude of the central field and also helps to support the large forces present in the high field magnets. The non-linearities can be well modeled by modern computer programs, and power supply technology has improved to the point that there is now no concern about putting the dipoles and quads on separate busses. Figure 10 compares the Tevatron with the SSC magnets.

Figure 10. A comparison of the Tevatron magnets and the SSC. The Tevatron has warm iron which necessitated a cryostat between the coil and iron. The SSC has exploited a cold iron design. The coil assembly is essentially the same. The Tevatron magnet is 15" across and the SSC cryostat is about 30" in diameter.

Finally modern refrigerators can recycle a section of the ring in a reasonable time if it is necessary. It is also worth noting that the superconducting magnets have proved to be extremely reliable.

Some other new techniques are now being developed. CERN is pioneering the concept of the two in one magnet which eliminates the double cryostat that was envisioned for the SSC and also uses coherence between the two closely spaced magnets to help return the flux and decrease the amount of iron needed. This does not come for free as the two rings are then strongly coupled. It is likely that any future machine will have only one cryostat in order to reduce cost. It is not clear what the post LHC hadron collider design will encompass. Higher field magnets, i.e. greater than 10 T, test seriously the strength of insulating materials because of the very high pressures need to confine the conductors. Perhaps the current density available can be increased somewhat, but it is likely that NbTi alloy is reaching its limit and Nb₃Sn with its promise of higher J_c remains a very difficult material to fabricate into accelerator magnets. Finally, at higher fields synchrotron radiation starts to eliminate the advantage that protons have enjoyed in the past. There remains much work before a 100 Tev collider can be proposed! In concluding this section, I hope that I have been able to describe the scope of the challenge that had to be faced by the Tevatron Proposal and how our success in meeting it has influenced the subsequent machine design.

THE TEVATRON COLLIDER

SOME MORE HISTORY

I would now like to go back to 1978-1979, when Lederman decided to opt for a scenario that would include the Pbar P collider after the Doubler was finished and working. At this point there was no commitment from the DOE to support a collider program at FNAL as BNL had been singled out earlier by the Ramsey Panel as the home laboratory for a large high luminosity P-P facility, and indeed, ISABELLE was under intense development at the time. However, the PbarP option looked very attractive for us. The energy would be 2 TEV. The early cooling experiments at CERN had gone very well and in July of 1978 they had approved the construction of a Pbar source and the conversion of the SPS to a PbarP collider. Although it was clear that CERN would beat us to collisions, we had a firm belief that the higher energy available at FNAL would open up new physics.

Thus, there was a vigorous detector and source design effort during the period of magnet development and machine construction. A number of workshops were held at Aspen, and in January 1977, a Colliding Beams Department under Jim Cronin, who was visiting on a Sabbatical, was established to study the detector and experimental area requirements. A Pbar source department within the Accelerator Division, was also created.

CDF

The firm decision for the Pbar-p option led to a reorganization and the CDF Department was formed and given clear responsibility for developing the B0 experimental area. I was appointed head and at that time the group of interested physicists was rather small and consisted of only 5 institutions. However, by the end of 1979, we had twelve different member institutions. Over the course of the preceding year, Prof. Giorgio Bellettini from Pisa had approached me and indicated an interest in joining CDF. Prof. K. Kondo from Tsukuba had shown a similar interest on the part of the Japanese. Both the Italian and Japanese physicists had an enormous impact on the design of the detector. It became clear the technologies available in Japan and Italy would greatly enhance our ability to build a sophisticated detector. In addition we picked up very strong support from within the US. Ultimately it was this large support from the community that enabled us to get funding for the colliding beams program. It was also the first time that US physicists were required to cooperate on such a large scale and it was the first time that FNAL managed a project with such diverse participation.

At the start there was a great deal of discussion of the form that the detector should take. Should it be calorimetric as UA2 or magnetic as UA1. If magnetic, which direction should the field point? In these discussions, we had a great deal of help from the electron-positron colliders and by the middle of 1978 we had chosen the axial magnet field configuration and we proceeded vigorously with this design. By 1979, we had a preliminary design, but still no commitment of support from the DOE for funding either source or the detector!

PBAR SOURCE

A small proton storage ring had been constructed to form a test bed for investigating the electron cooling technique. It was started in May 1976 as a result of the discussions at the workshop mentioned earlier. It finally worked in October of 1980, somewhat later than the AA at CERN. However it gave valuable experience to the Accelerator Division and it actually formed the basis for a preliminary design for a source which was prepared in mid 1981. Lederman formed a small group of experts to review it before presentation to the DOE for funding. The review panel unanimously recommended that the design did not exploit the ultimate capabilities of the Tevatron, and that it should be much more ambitious in its goals. In the meantime, the AA had come on line at CERN and demonstrated beautifully the capabilities of stochastic cooling. As a result, a completely new design for the source was undertaken. The electron cooling was eliminated and an additional "debuncher" ring was put in front of the accumulator ring that considerably increased the phase space density of the bunch before it was put into the stochastic stacking system in the accumulator. This was later copied by CERN and is the key to high intensity Pbar sources. By October 1982, the new proposal was ready, was reviewed and was accepted by the laboratory.

IT ALL COMES TOGETHER!

By January 1981, CDF had a complete design for the detector, and the DOE held a review of the project. Many prototype elements had been built and tested with the support of laboratory funds. Both the Italians and Japanese had committed manpower and money to the project, and we felt that it was an excellent design. The DOE was shocked by the cost estimate of about \$49 M...a number which nowadays seems quite modest. The problem was eventually overcome through a suggestion of Roy Schwitters who had joined as Co-spokesman in September of the previous year. The idea was to stage the detector and have the profile of its capabilities match the expected performance of the collider as it was being commissioned. This spread out the impact of the cost over more years, and helped alleviate fears that the project would bankrupt the US equipment budget. It was also at this time that the laboratory proposed a second collision area at D0. CDF wanted to proceed with the construction of components as rapidly as possible, but the DOE would not let any construction funds be spent until there was an accepted design for the complete project. Finally, in October 1983 an overall plan and cost estimate was accepted and the Project was called Tevatron I. It included the experimental halls at B0 and D0 and all of the necessary machine components to support two collision areas. The detectors were handled as separate construction projects and were managed by FNAL but with heavy participation by the members of the collaborations. D0 was started somewhat after CDF, but is now fully functional as can be seen by the contributions to the 1994 Glasgow HEP Conference. Each collaboration represents more than thirty institutions and has over four hundred members. It is a different way of doing physics and I'm sure was not foreseen by those early workers that built Ada!

CONCLUSION

Finally, I would like to show four results from hadron colliders. The first is Figure 11 and is taken from the work of the UA2 collaboration in early 1982. This is the first Lego plot of a dijet event shown at a conference, and I have always looked at it as start of parton collider physics. It shows in splendid detail parton scattering and was the precursor of all the wonderful physics that came out of the UA1 and UA2 experiments.

Figure 11. First Lego plot of parton-parton scattering as shown by the UA2 collaboration in early 1982. (from Physics Letters 1982, 118B, p 208)

The additional figures are from recent CDF results. Figure 12 shows the inclusive jet cross section vs transverse energy of the jet to greater than 400 GeV. The NLO QCD calculation is shown for comparison. The cross section spans over 9 orders of magnitude and probes the high Q^2 behavior of QCD. It is the direct descendent of Figure 11!

Figure 12 CDF inclusive jet cross section vs E_t

Figure 13 shows yet another probe of high mass states taken from recent CDF work showing evidence for the top. (Phys. Rev. D 50, 2966 (1994)) The figure shows the mass reconstructed from the selected lepton plus four jets sample that have a b-tag. This technique relies on reconstructing masses by using the observed jet energy and relating it to the parton energy. Eventually, with a large sample of events, this will provide a very good way to measure the top mass. It will have internal checks in that one of the W's is reconstructed from its decay via light quarks.

Figure 13 Mass spectrum from CDF lepton plus four jet plus b-tag sample.

I have picked these examples because they all involve measuring jets. Finally, it is interesting to see how well exclusive states can be reconstructed. Figure 14 shows the mass spectrum of a B that decays into J/ψ plus K_s , where the secondary decay vertex of the B was identified by the Silicon Vertex Detector and the J/ψ and K_s reconstructed from their tracks in the central tracking chamber. The K_s also has a vertex well displaced from that of the B decay.

Figure 14 CDF reconstruction of a B. The decay chain was through J/ψ plus a K short. The secondary vertex is from the B decay and is identified by the silicon vertex detector. The J/ψ is reconstructed through the $\mu^+ \mu^-$ tracks and the K_s from the large decay distance of the secondary vertex and the reconstructed mass from the $\pi^+ \pi^-$ associated tracks. In each case the tracks are measured in the central tracking chamber.

The hadron colliders continue to give surprisingly good results. The events are remarkably clean and easy to reconstruct, contrary to the expectations of some physicists. It is exciting that the top is so massive, but it would be even more so if there were some hint of what the scale is for the next level! Perhaps the LHC will tell us.

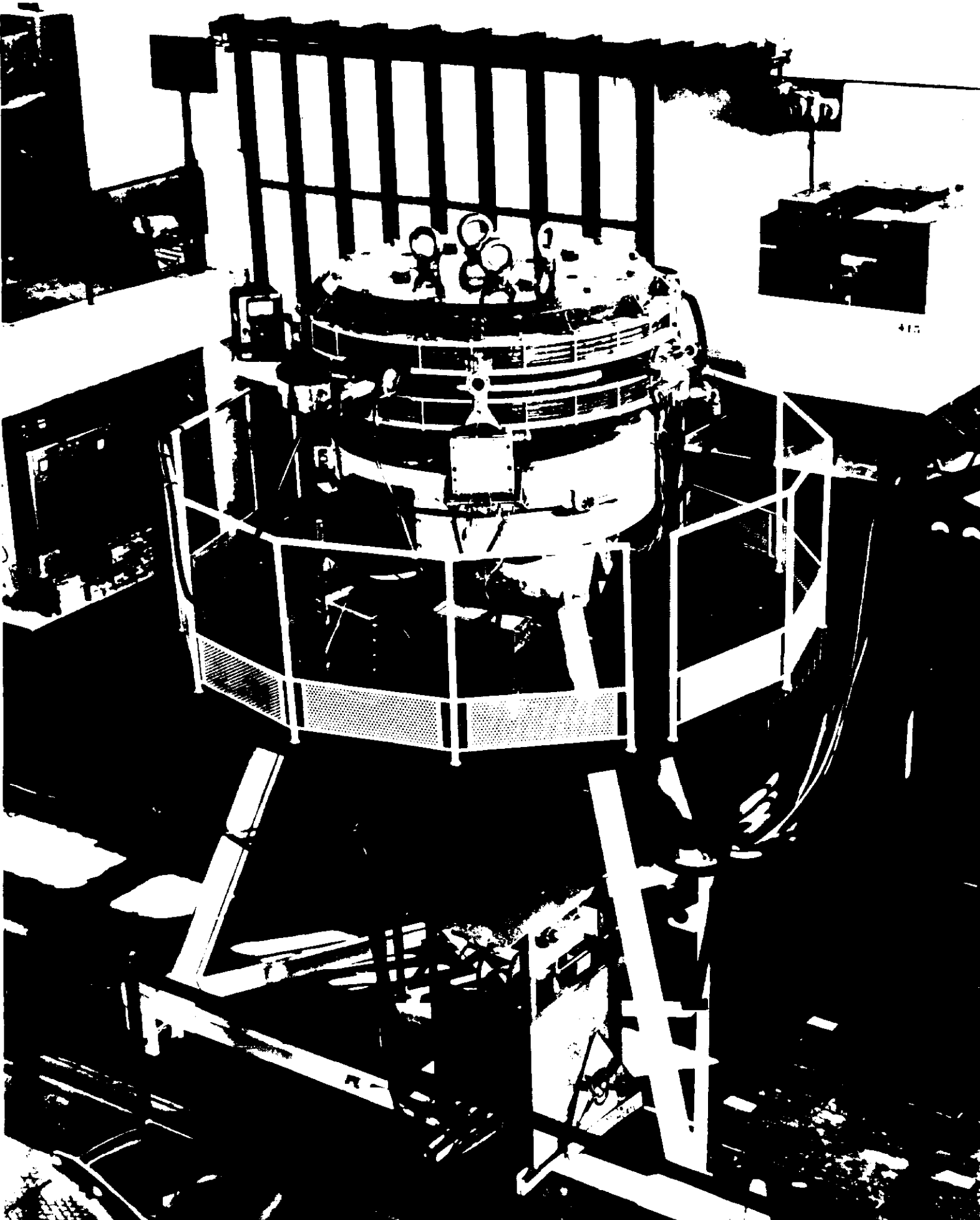

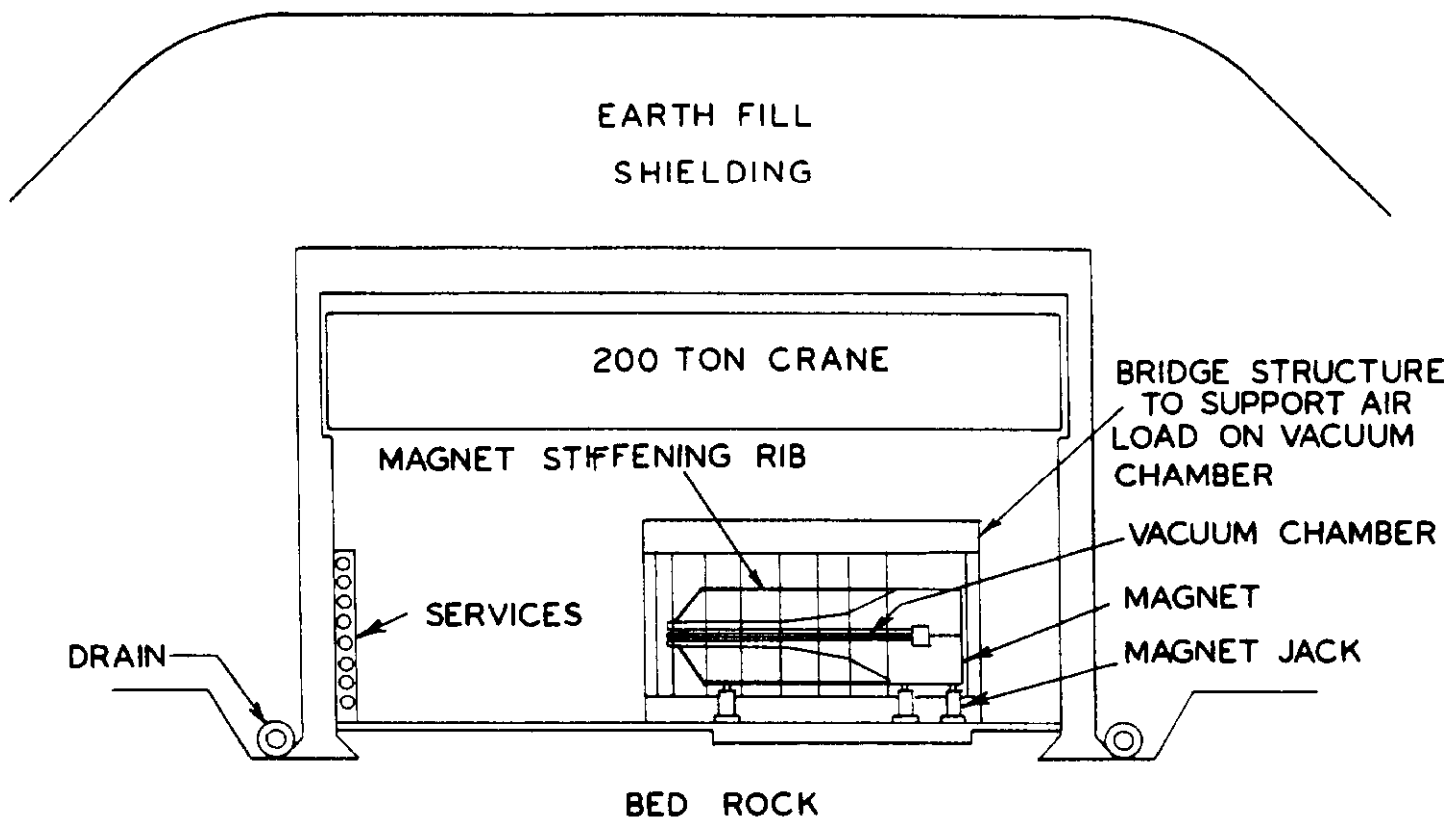

TUNNEL SECTION
SCALE 1/16"=1'
FIGURE 8

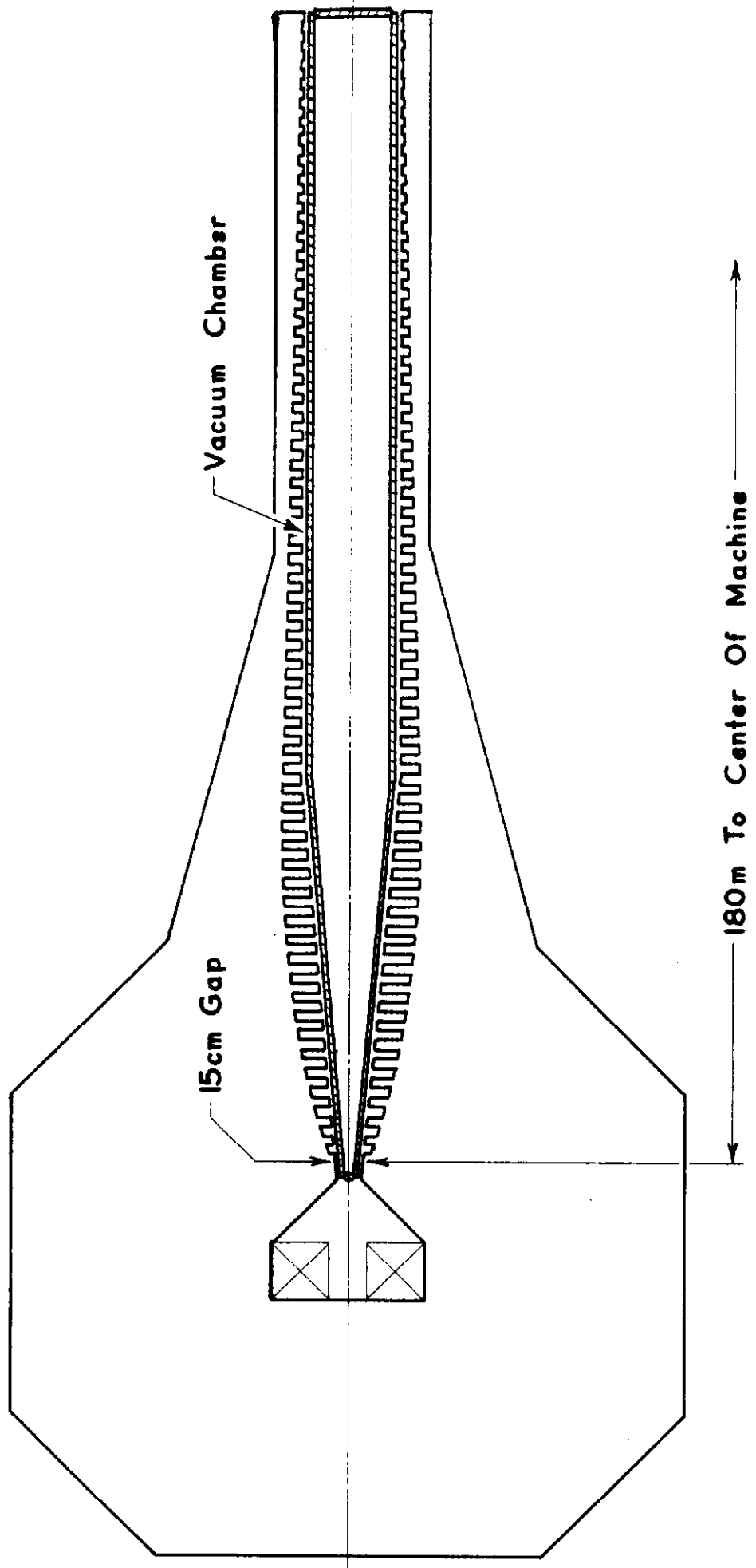

Cross Section View Of Magnet
Showing Vacuum Chamber In Place.

Figure 7

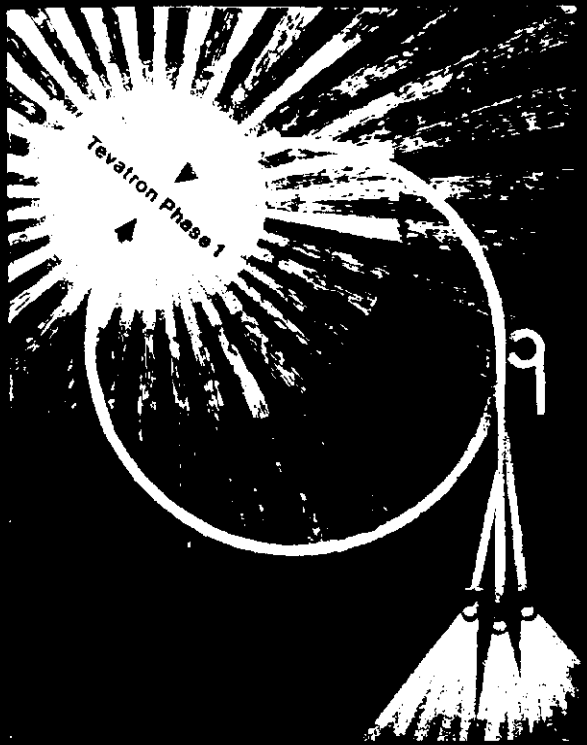

Fermilab TeV Program
 Superconducting Magnet Ring

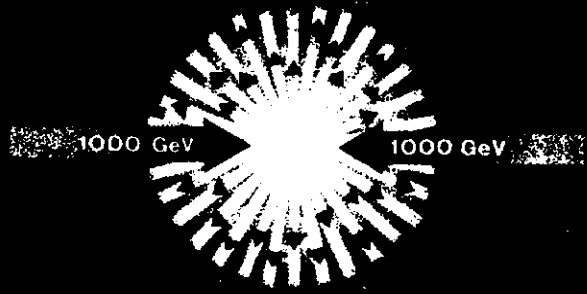

ENERGY DOUBLER
 ENERGY SAVER
 COLLIDING BEAMS

1977

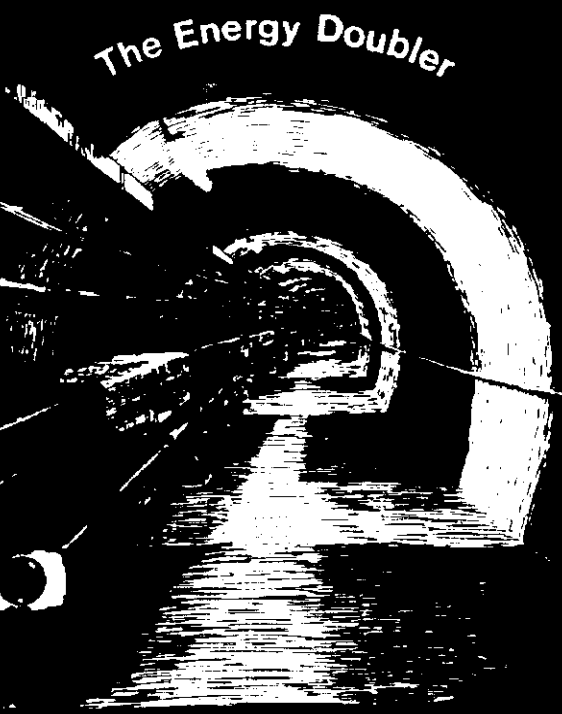
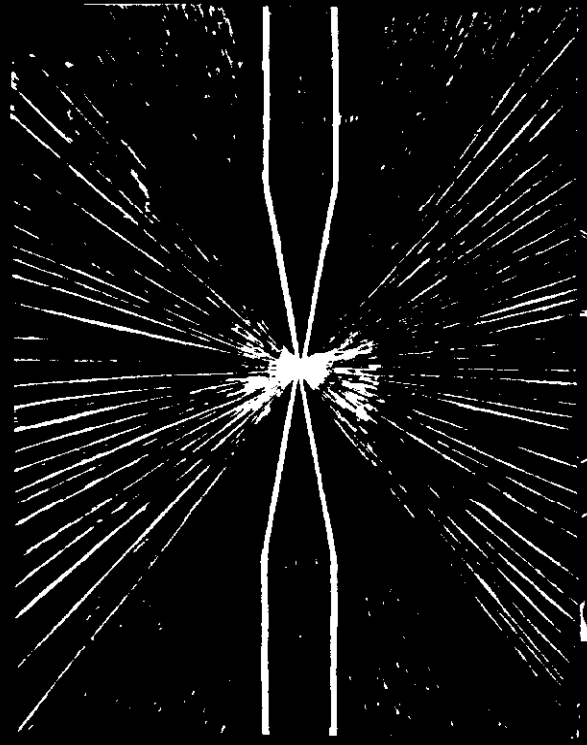

FIRST STORE IN A BIG ONE.

4

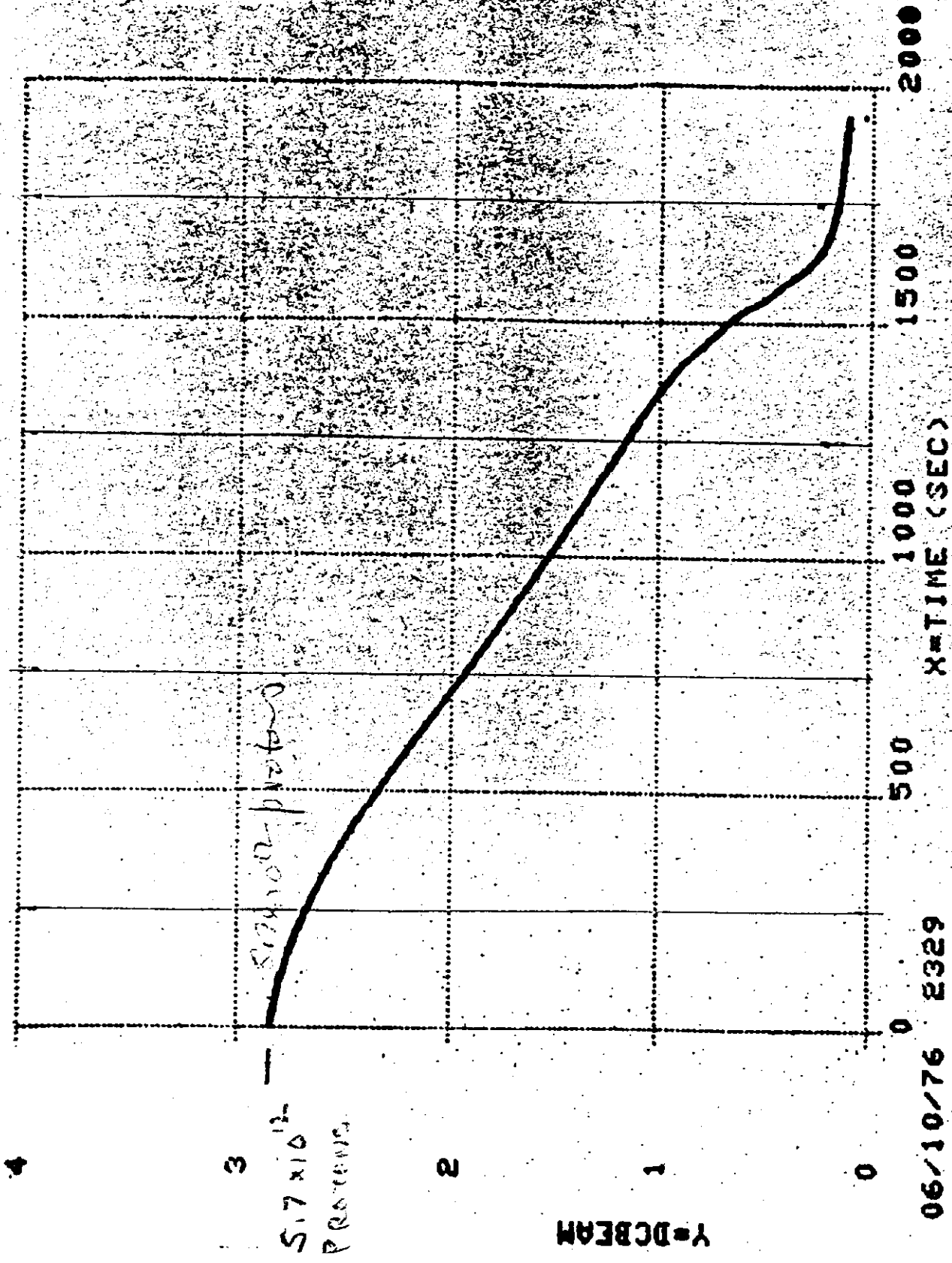

5.7 x 10¹²
PROTONS

S124100-10260

Y=DCBEAM

06/10/76 2329

TOROID

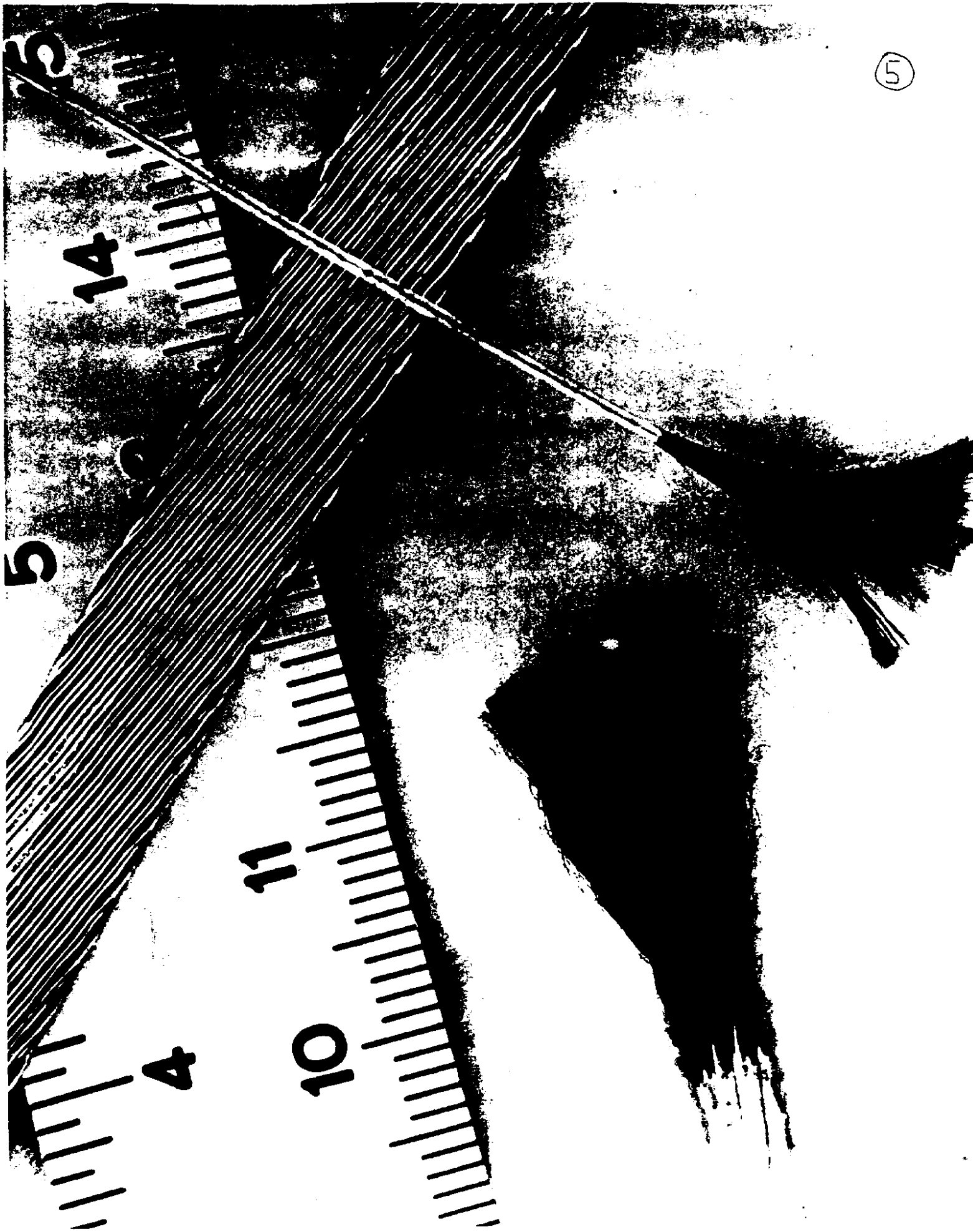

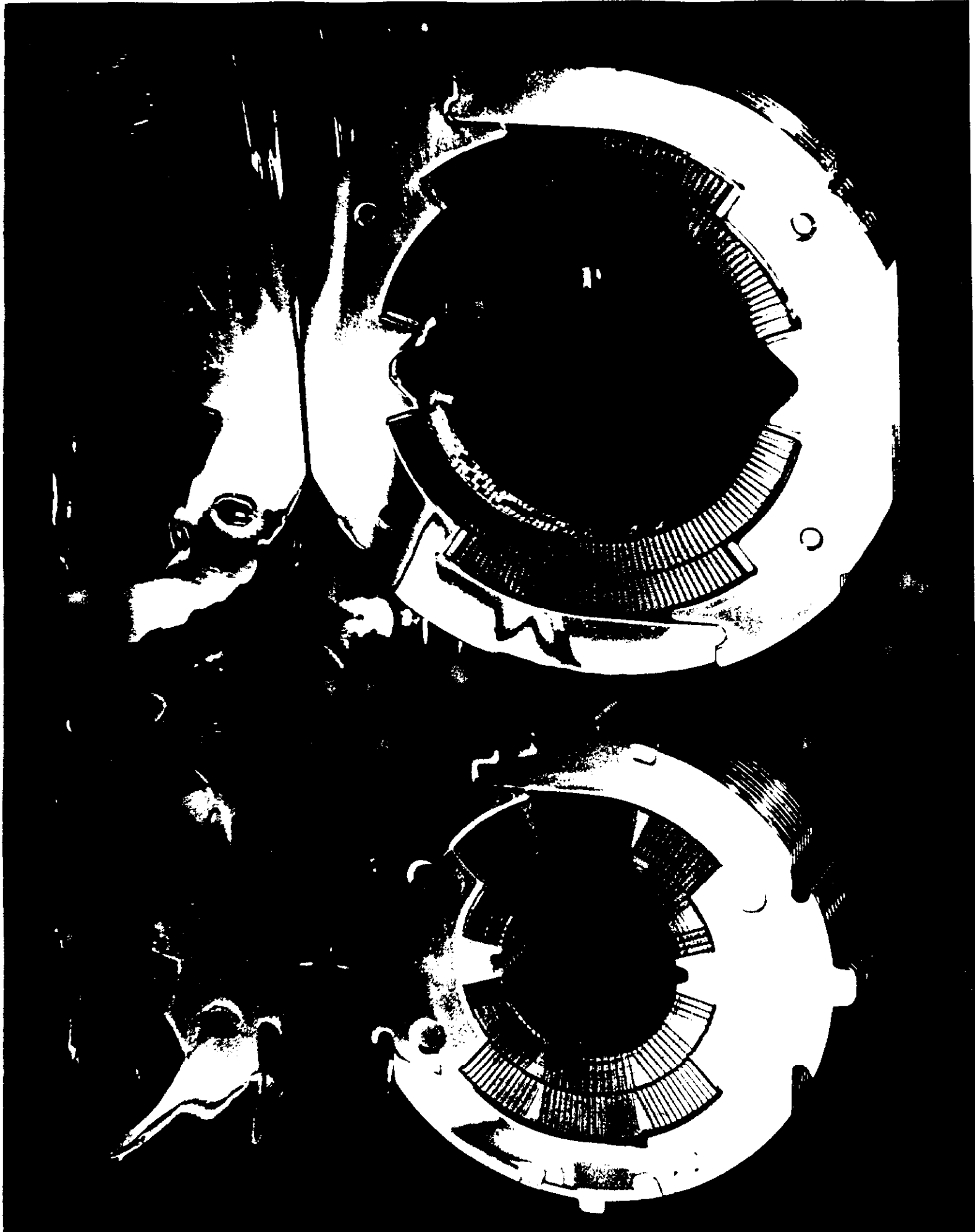

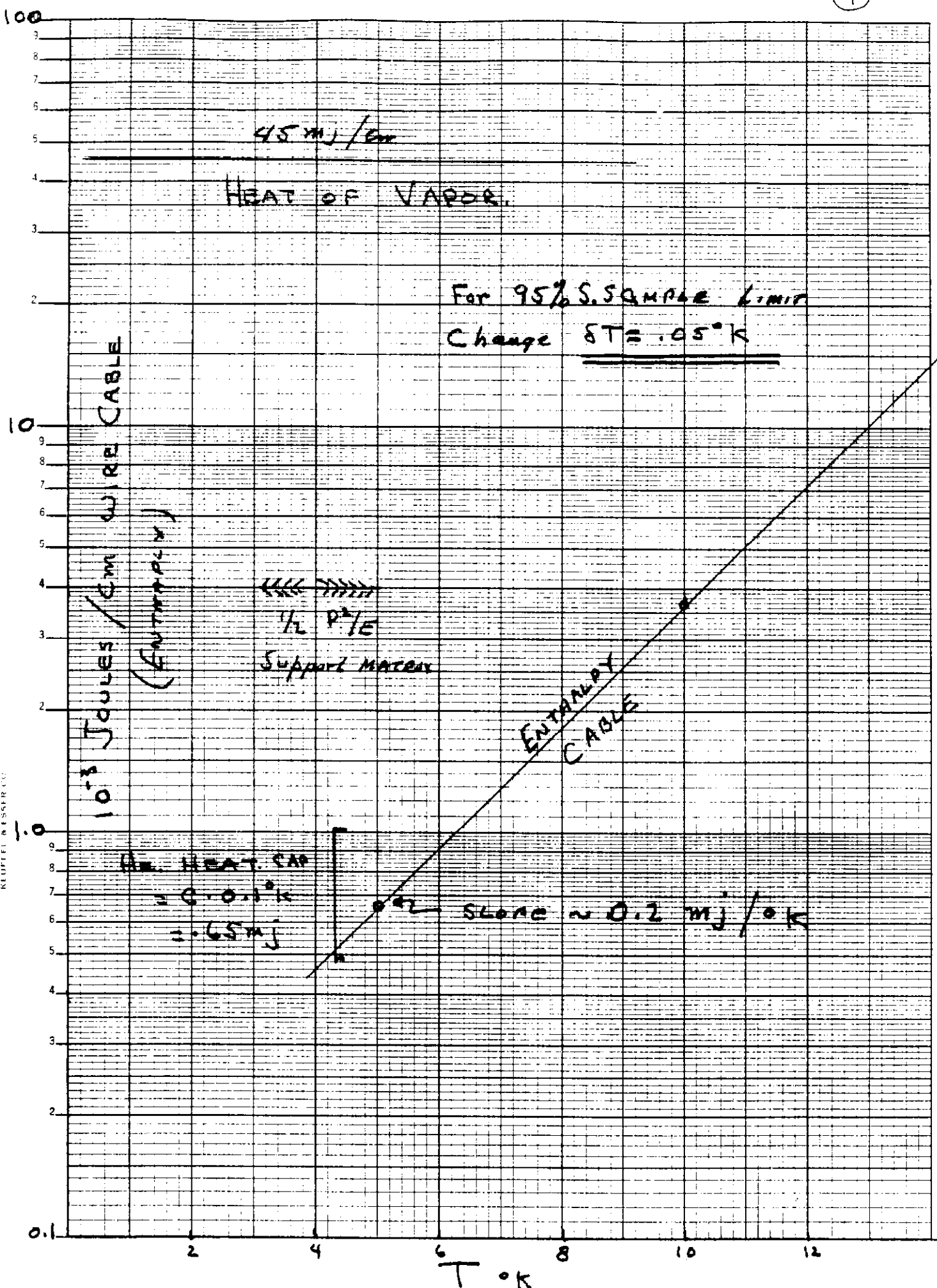

K&E SEMI LOGARITHMIC 46 5493
 5" x 11" 1/2" x 70 DIVISION
 KEUFFEL & ESSER CO.

8a

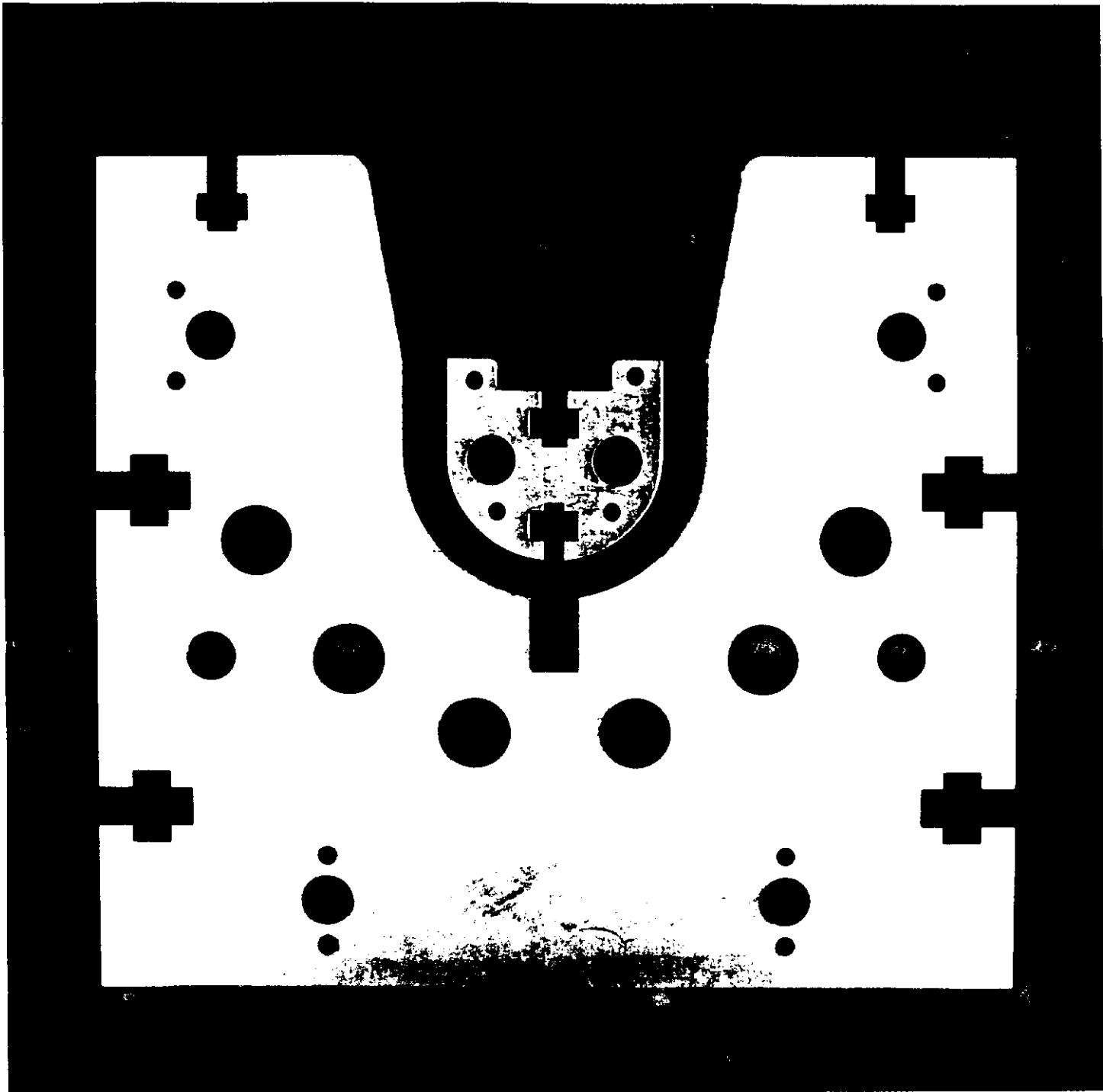



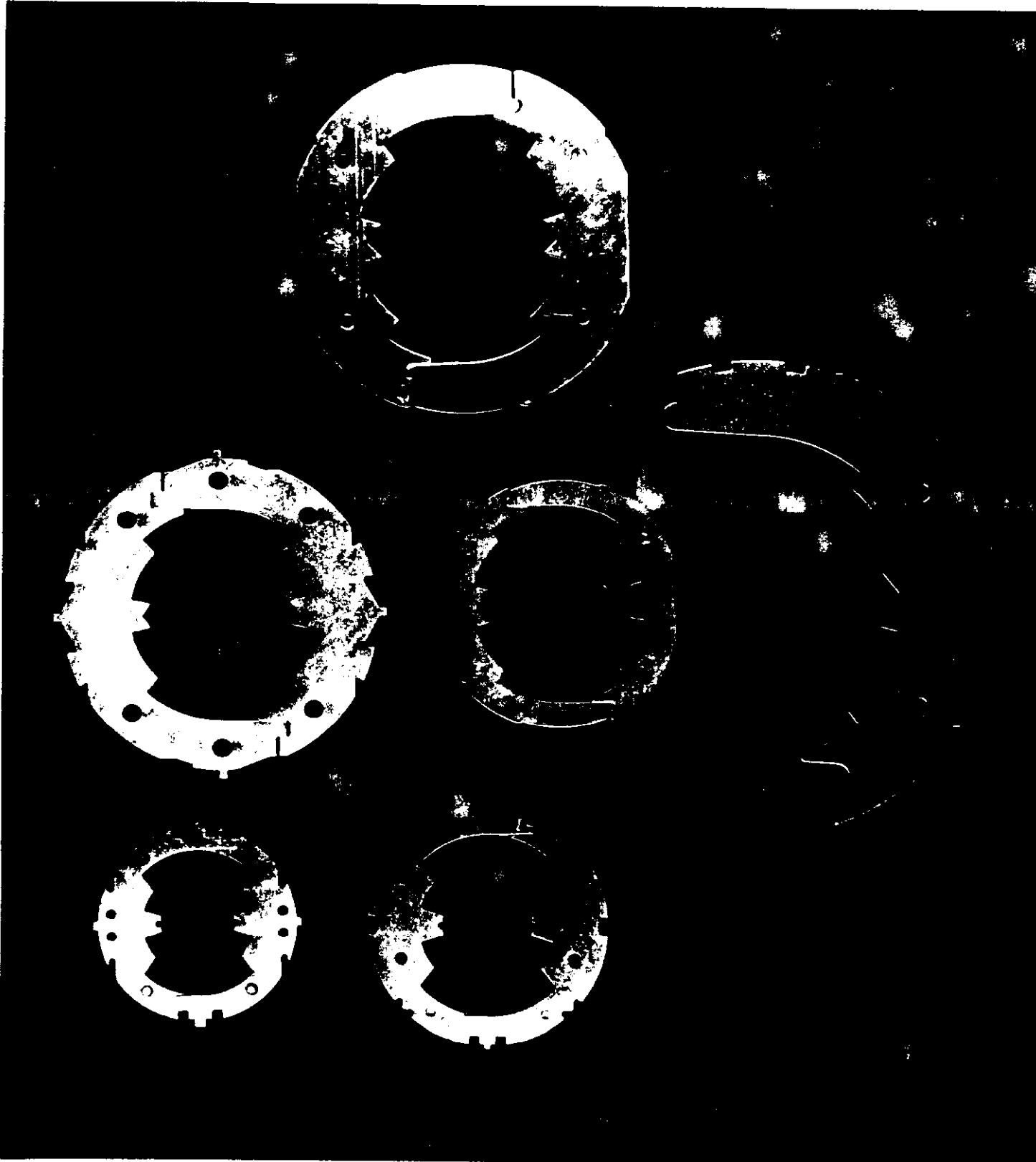

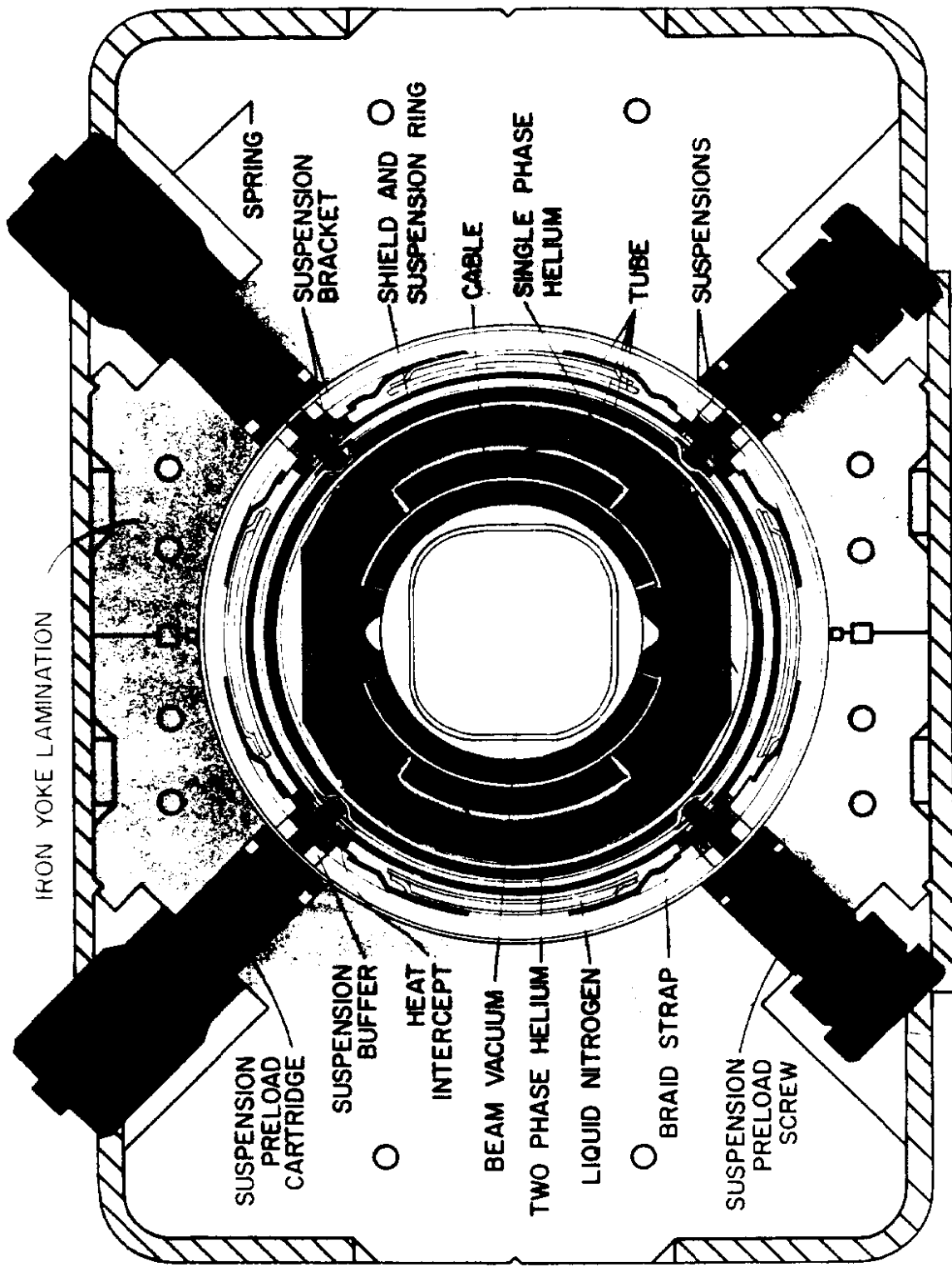

IRON YOKE LAMINATION

SPRING
SUSPENSION BRACKET
SHIELD AND SUSPENSION RING
CABLE
SINGLE PHASE HELIUM
TUBE
SUSPENSIONS

SUSPENSION PRELOAD CARTRIDGE
SUSPENSION BUFFER
HEAT INTERCEPT
BEAM VACUUM
TWO PHASE HELIUM
LIQUID NITROGEN
BRAID STRAP
SUSPENSION PRELOAD SCREW

SSC 50mm Collider Dipole Cryostat Cross Section

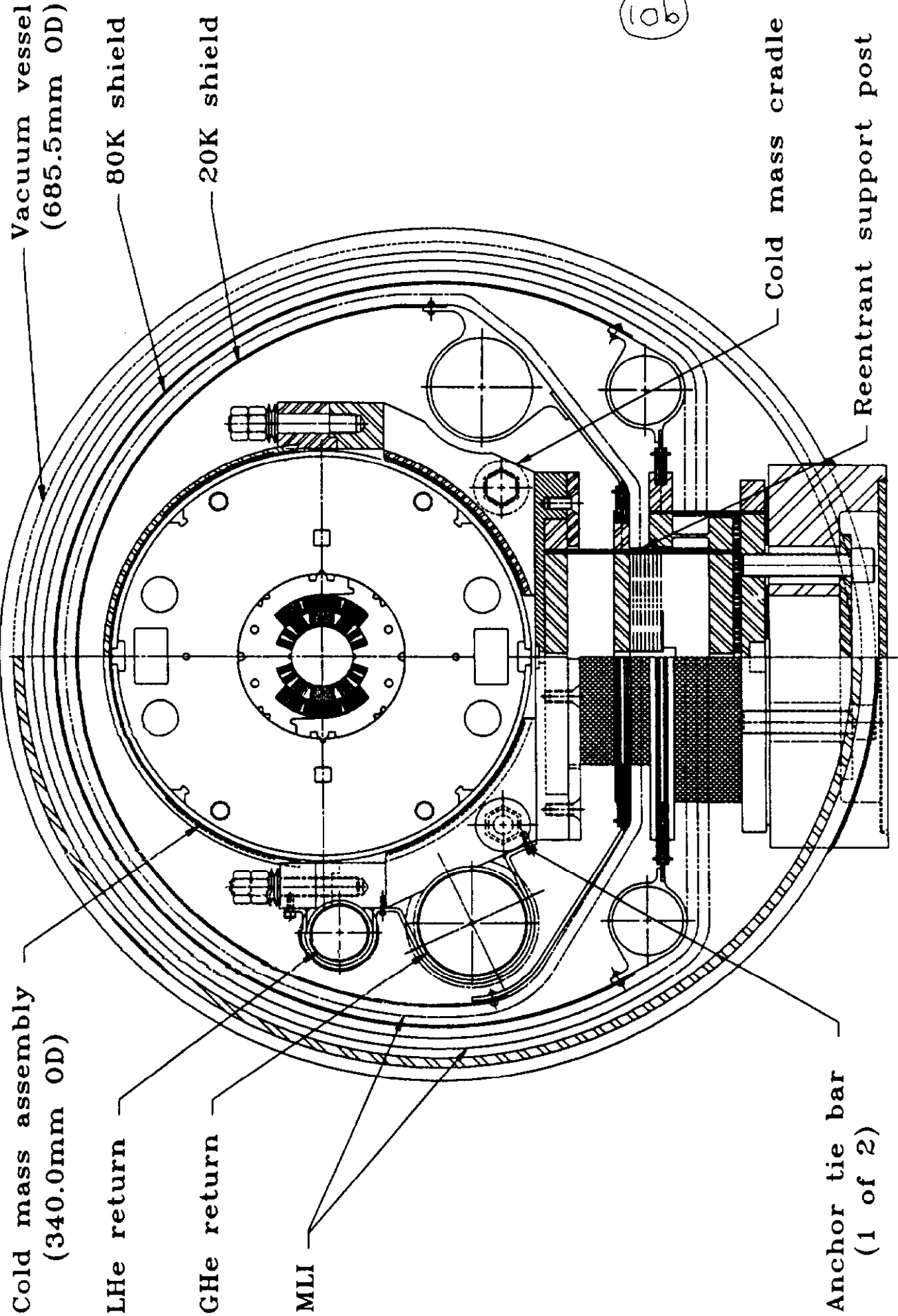

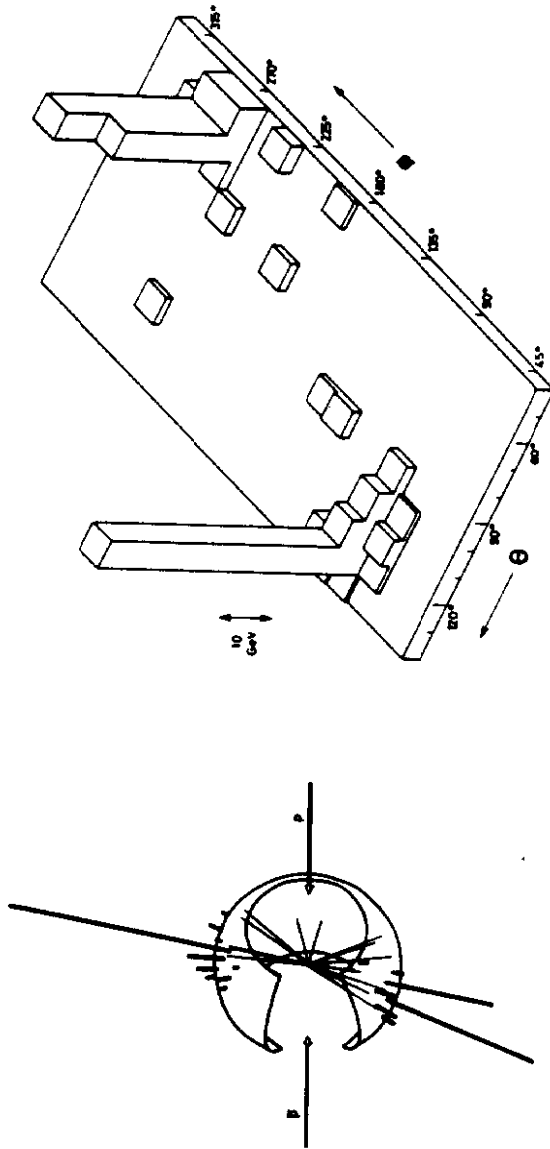
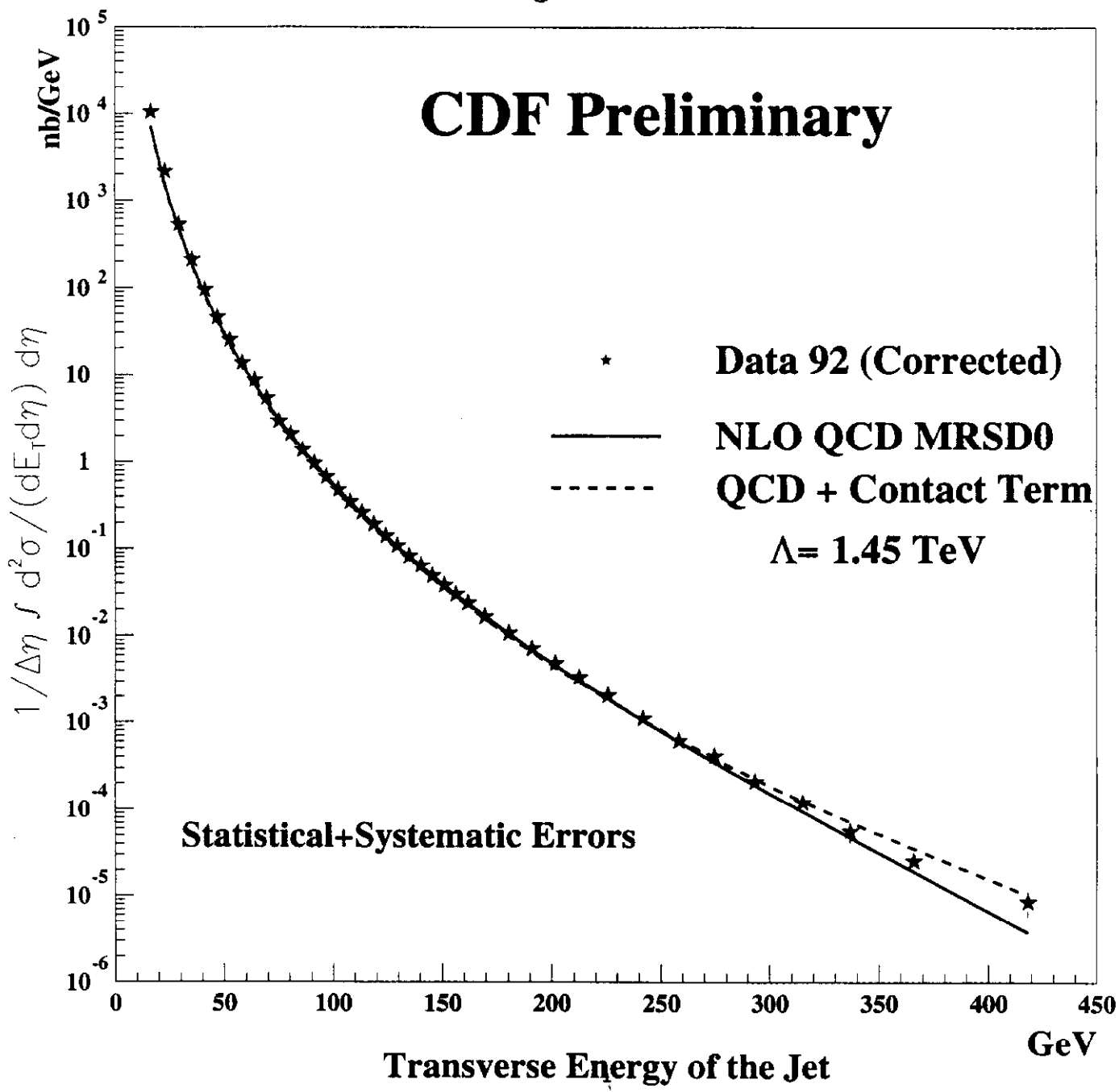

Figure 11

A more quantitative evidence for the appearance of jets as the total transverse energy increases is given in Fig. 12. Energy clusters are defined and the fraction of total transverse energy contained in the highest and the two highest energy clusters is calculated. These average fractions are plotted as a function of the total transverse energy ΣE_T . It is clear that as ΣE_T increases one or two clusters carry most of it. It should be emphasized that the average number of cells in a single cluster never exceeds 5.

Inclusive Jet Cross Section

CDF Preliminary



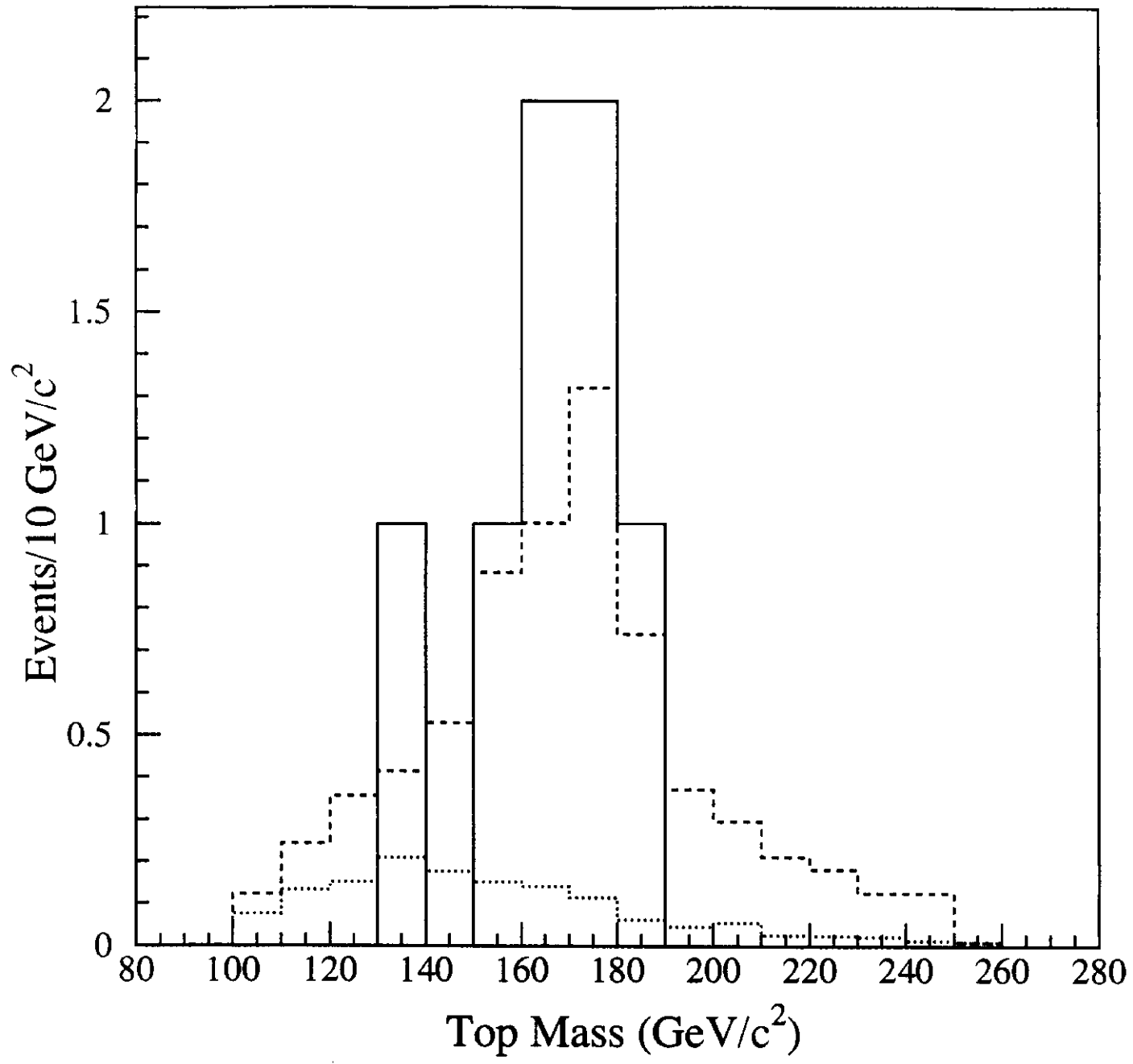

CDF Preliminary

