

Bulletin 122

DEPARTMENT OF THE INTERIOR

FRANKLIN K. LANE, SECRETARY

BUREAU OF MINES

VAN. H. MANNING, DIRECTOR

THE PRINCIPLES AND PRACTICE OF SAMPLING  
METALLIC METALLURGICAL MATERIALS

WITH SPECIAL REFERENCE TO THE  
SAMPLING OF COPPER BULLION

BY

EDWARD KELLER



WASHINGTON  
GOVERNMENT PRINTING OFFICE

1916

The Bureau of Mines, in carrying out one of the provisions of its organic act—to disseminate information concerning investigations made—prints a limited free edition of each of its publications.

When this edition is exhausted, copies may be obtained, at cost price, only through the Superintendent of Documents, Government Printing Office, Washington, D. C.

The Superintendent of Documents *is not an official of the Bureau of Mines*. His is an entirely separate office, and he should be addressed:

SUPERINTENDENT OF DOCUMENTS,  
*Government Printing Office,*  
*Washington, D. C.*

The general law under which publications are distributed prohibits the giving of more than one copy of a publication to one person. The price of this publication is 20 cents.

*First edition. September, 1916*

# CONTENTS.

---

|  | Page. |
|--|-------|
| Introduction.....  | 3     |
| Part I. Theoretical considerations underlying sampling.....        | 4     |
| Purpose of sampling.....   | 4     |
| Samples of homogeneous materials.....                              | 4     |
| Samples of heterogeneous materials.....                            | 5     |
| Some laws of physics pertaining to sampling.....                   | 5     |
| Molten alloys.....   | 5     |
| Solid alloys.....  | 5     |
| Bakhuis Roozeboom's classification of binary-alloys solutions..... | 6     |
| Two other classes of binary-alloy solutions.....                   | 7     |
| Conclusions from discussion of binary-alloy curves.....            | 8     |
| Errors of observation and interpretation.....                      | 10    |
| Results of sampling low-grade copper-silver alloys.....            | 12    |
| Tabulated results of silver determinations.....                    | 12    |
| Discussion of tabulated results.....                               | 14    |
| Experiments of Heycock and Neville.....                            | 14    |
| Investigations by Heyn.....  | 15    |
| Observations by Hunt.....  | 15    |
| Example of incomplete interpretation.....                          | 16    |
| Terminology of sampling:   |       |
| "Segregation" and "liquation".....                                 | 16    |
| Example of need of definite terms.....                             | 18    |
| "Solvent" and "solute".....  | 19    |
| "Hypoeutectic" and "hypereutectic".....                            | 19    |
| "Alloys" and "bullions".....                                       | 19    |
| Part II. Practical sampling.....                                   | 21    |
| Practicability of making homogeneous alloys.....                   | 21    |
| Experiments by the author.....                                     | 21    |
| Tabulated data.....  | 22    |
| Comments on tabulated data.....                                    | 23    |
| Methods of controlling direction of diffusion in an alloy.....     | 27    |
| Sampling molten furnace charges.....                               | 27    |
| Results of tests.....  | 28    |
| Sampling molten stream of metal.....                               | 30    |
| Two methods of sampling molten stream of metal.....                | 30    |
| Details of sampling method commonly used.....                      | 31    |
| Ladle-sampling tests of doré bullion.....                          | 32    |
| Raht's description of sampling lead bullion.....                   | 33    |
| Sampling molten pig iron.....                                      | 34    |
| Sampling miscellaneous metallic scraps, etc.....                   | 35    |
| Sampling solid materials.....                                      | 35    |
| Extraneous matter in bullion.....                                  | 35    |
| Tabulated data on effect of extraneous matter.....                 | 36    |
| Effect of mold wash on drill samples.....                          | 36    |
| Effect of moisture in bullion.....                                 | 37    |

|  | Page. |
|--|-------|
| Part II. —Practical sampling—Continued.  |       |
| Relation of shape to diffusion in castings-----  | 39    |
| Bearing of shape of casting on method of sampling-----   | 39    |
| Sampling of bars-----  | 40    |
| Sampling by drilling-----  | 41    |
| Sampling by sawing or planing-----   | 42    |
| Sampling castings having a bevel-----  | 43    |
| Relation of bevel to sampling-----   | 43    |
| Algebraic expression of effect of bevel-----   | 45    |
| Bearing of inner structure of bar-----   | 47    |
| Sampling of plates or slabs-----   | 48    |
| Sampling by drilling and punching-----   | 49    |
| Sampling by sawing-----  | 49    |
| Sampling by gouging or chipping-----   | 49    |
| Use of templets in sampling-----   | 49    |
| Adaptation of theory to practice in sampling-----  | 49    |
| Templet for sampling by sawing-----  | 51    |
| Templet for sampling by drilling-----  | 52    |
| Templet sections for drilling and punching should be squares or<br>the closest possible approach thereto-----                          | 53    |
| Size of templet sections-----  | 54    |
| Templet for whole, half, or quarter bar or plate-----  | 54    |
| Templet for sampling circular castings by drilling-----  | 55    |
| Proportion of pieces to be taken for sampling a lot-----   | 56    |
| Sampling lot of bars of different sizes-----   | 57    |
| Results of sampling experiments-----   | 58    |
| Great production of copper bullion-----  | 58    |
| Technical difficulties in sampling copper bullion-----   | 59    |
| Enrichment of upper layers of converter-copper bars-----   | 59    |
| One-half of bars should be drilled with smooth surfaces up-<br>Comparative results of sampling by top and by bottom drill-<br>ing----- | 59    |
| Effect of drilling method on weights of samples-----   | 60    |
| Effect of diffusion phenomena-----   | 61    |
| Determinations of silver and gold in copper bullion-----   | 62    |
| Results of silver determinations by two templets-----  | 64    |
| Results of silver determinations with large numbers of pigs-----   | 66    |
| How sampling errors offset each other-----   | 66    |
| Results of sampling refined copper bullion-----  | 68    |
| Results of sampling refined copper anodes-----   | 69    |
| Results of sampling refined copper anodes with 99-hole<br>templet-----   | 71    |
| Comparative results of shot sampling and of drill sampling-----  | 73    |
| Irrational templet will not give correct sample-----   | 74    |
| Errors arising from drill samples from edge zone-----  | 75    |
| Other examples of error in drill samples from bevel zone-----  | 75    |
| Method of correcting errors in sampling bevel zone-----  | 77    |
| Results of sampling doré bar to determine gold content-----  | 80    |
| Results of duplicate silver assays of converter-copper bullion-----  | 80    |
| Part III. Procedure and equipment used in sampling-----  | 81    |
| Sampling by shotting-----  | 82    |
| Sampling by sawing-----  | 82    |
|  | 83    |



| Part III.—Procedure and equipment used in sampling—Continued. | Page. |
|---|-------|
| Sampling by drilling.....                                     | 84    |
| The templet.....  | 84    |
| Arrangement of drilling room.....                             | 84    |
| Locating drill holes without chalking.....                    | 86    |
| Drill presses and drills.....                                 | 88    |
| Grinding of drillings.....                                    | 90    |
| Reduction of drillings sample.....                            | 91    |
| Results of screening a given lot of drillings.....            | 92    |
| Removal of iron or steel from drillings samples.....          | 93    |
| Use of punch in sampling.....                                 | 94    |
| Preparing sample for determining suboxide in copper.....      | 95    |
| Sampling by filing.....                                       | 95    |
| Résumé.....   | 96    |
| Publications on mineral technology.....                       | 97    |

---

TABLES.

---

|   | Page. |
|---|-------|
| TABLE 1. Results of determinations of silver in blocks of low-grade copper-silver alloys.....   | 13    |
| 2. Results of determinations of distribution of precious metals and impurities in blocks of copper bullion.....                                     | 22    |
| 3. Results of sampling copper bullion by pouring shotted samples from ladle compared with assays of skull and stream samples.....                   | 28    |
| 4. Results of analyses of hot-ladle and of skulled-ladle samples of doré bullion.....   | 32    |
| 5. Results of determinations showing reduction of average copper content in different types of copper bullion by foreign materials.....             | 36    |
| 6. Results of test of effect of mold wash on metal contents of drill samples.....   | 37    |
| 7. Results of analyses of samples obtained by drilling and by sawing, five-bar method.....  | 53    |
| 8. Results of analyses of samples of converter copper slabs drilled with the upper or rough surface up and with the lower or smooth surface up..... | 60    |
| 9. Data regarding effect of drilling method on weight of samples.....   | 61    |
| 10. Silver and gold contents in zones of converter-copper slab.....   | 65    |
| 11. Results of assays of samples of converter-copper slabs.....   | 66    |
| 12. Monthly average results of assays of western shotted and eastern drilled samples of gas-finished converter copper.....                          | 68    |
| 13. Results of assaying samples of auriferous and argentiferous converter copper.....   | 69    |
| 14. Results of assaying samples of slab of refined converter copper.....  | 71    |
| 15. Results of assays of samples of refined-copper anodes.....  | 74    |
| 16. Monthly average results of assays of western shotted and eastern drilled samples of refined converter copper.....                               | 74    |

|  | Page. |
|--|-------|
| TABLE 17. Average results of 10 assays of two kinds of samples of copper-bullion cylinders ..... | 75    |
| 18. Results of duplicate silver assays of converter-copper bullion....                           | 81    |
| 19. Results of silver assays of copper bullion from 23 furnace charges.....                      | 83    |
| 20. Sizes, weights, and assays of parts of converter-copper sample..                             | 92    |
| 21. Sizes, weights, and analyses of parts of arsenical-copper sample..                           | 93    |

---

## ILLUSTRATIONS.

---

|   | Page. |
|---|-------|
| PLATE I. Results of assay of single slab and average assay of 10 slabs of copper bullion by drilling method, showing distribution of gold and silver content..... | 62    |
| II. Results of assays of slab of converter copper bullion sampled in eight zones by several methods.....  | 64    |
| III. Results of sampling the four quarters of a refined copper bullion slab by drilling.....  | 70    |
| IV. Results of sampling converter copper slab, showing extent of weight and assay errors incident to sampling bevel zone by cutting.....                          | 78    |
| V. Results of sampling converter copper slab, showing extent of weight and assay errors incident to sampling bevel zone by drilling .....                         | 78    |
| VI. Results of assays of doré bullion bar, showing distribution of gold content, in parts per 1,000.....  | 80    |
| VII. Templets for drilling various copper slabs.....  | 84    |
| VIII. Drillman laying out templets.....   | 86    |
| IX. Drilling the holes.....   | 86    |
| X. Drill room at second plant, showing method of marking, drilling, and handling slabs.....   | 86    |
| XI. Near view of drill, showing details of drill and carriage for slabs, second plant.....  | 86    |
| XII. Method of loading the drilled slabs, second plant.....   | 86    |
| XIII. <i>A</i> , Twist drills; <i>B</i> , Hance No. 2 mill.....   | 88    |
| FIGURE 1. Freezing-point diagrams of binary alloys in which the two substances are miscible in all proportions.....   | 6     |
| 2. Freezing-point diagrams of binary alloys in which the two substances are immiscible or only partly miscible.....   | 7     |
| 3. Freezing-point diagram of binary alloys in which the two substances separate into two layers.....  | 8     |
| 4. Freezing-point diagram of two substances forming a chemical compound.....  | 8     |
| 5. Size of cube used in experiments with copper-silver alloys, showing where 28 samples were taken.....   | 12    |
| 6. Freezing-point diagram for an alloy of copper and copper suboxide.....   | 15    |
| 7. Character of blocks of copper bullion and of steel used in experiments to show diffusions in alloys.....   | 23    |

|  | Page. |
|--|-------|
| <b>FIGURE 8.</b> Distribution of silver and gold in bar of gas-finished converter copper.....  | 25    |
| 9. Distribution of silver and gold in bar of black copper.....   | 26    |
| 10. Templet used in drilling skulls for samples.....   | 29    |
| 11. Sections of stream of molten charge of bullion.....  | 31    |
| 12. Sections of hypothetical bullion bar.....  | 40    |
| 13. Cross section of bar of bullion, showing freezing and geometric centers .....  | 43    |
| 14. Bevel of bar or plate, showing geometrically correct relation of templet section and bevel for a drill hole through bevel.....             | 44    |
| 15. Views showing relation of drill-hole cylinder, or sample, to various bevels.....   | 46    |
| 16. The ungula .....   | 47    |
| 17. Five-bar templet for English method of sampling by sawing....  | 51    |
| 18. Ideal templet for sampling bars by sawing.....   | 51    |
| 19. Hollow cylinder of bullion sawed for sample taken according to Morse method.....   | 52    |
| 20. Five-bar templet for sampling by drilling or punching, five-bar method .....   | 52    |
| 21. Five-bar templet for sampling by drilling and by sawing.....   | 53    |
| 22. Views showing why templet sections should be approximate squares.....  | 54    |
| 23. Templets for sampling castings of circular cross section by drilling.....  | 56    |
| 24. Determination of silver content and distribution in gas-finished converter bar by two templets.....  | 67    |
| 25. Distribution of silver in thin plate of copper.....  | 70    |
| 26. Silver distribution in furnace-refined copper bullion anode....  | 72    |
| 27. Results of assays of furnace-refined converter copper bullion anode by 99-hole templet.....  | 73    |
| 28. Part of slab of converter copper bullion shown in Plate II, showing silver contents of parallelepipeds and corresponding drill holes ..... | 76    |
| 29. Thomson method of marking drill-hole locations on bullion slabs .....  | 87    |
| 30. Jones sampler .....  | 91    |
| 31. Punch for sampling lead bullion or other soft alloys.....  | 95    |



# THE PRINCIPLES AND PRACTICE OF SAMPLING METALLIC METALLURGICAL MATERIALS, WITH SPECIAL REFERENCE TO THE SAMPLING OF COPPER BULLION.

---

By EDWARD KELLER.

---

## INTRODUCTION.

The work covered by this report was undertaken at the request of Dr. J. A. Holmes, late Director of the Bureau of Mines, to whom the writer had been recommended by C. W. Goodale and E. P. Mathewson, of Butte and Anaconda, Mont. The director's offer was accepted for the honor it conferred and for the useful results that might be promulgated by the work in the technical field covered. The investigation was facilitated by permission to visit various works and sometimes by contributions of important definite information on a given subject. It is therefore with pleasure that acknowledgment of courtesies is made to the following corporations and gentlemen: Anaconda Copper Mining Co., Raritan Copper Works, Baltimore Copper Smelting & Rolling Co., United States Refining Co., American Smelting & Refining Co., B. B. Thayer, A. C. Clark, A. L. Walker, William H. Peirce, E. A. Cappelen Smith, H. H. Alexander, F. C. Newton, S. Rolle, R. W. Deacon, N. W. Pierce, O. C. Martin, C. N. Sappington, James K. Thomson, W. G. Derby, and the assistants of the writer, K. W. McComas and W. L. Raup.

In this report considerable space has been devoted to general and theoretical principles on the ground that under modern conditions the best results in any field of activity can be attained only with the aid of an adequate knowledge of the best theories underlying the practice. The diffusion of such knowledge in the field of sampling metallic metallurgical materials appears to have been quite insufficient, and it is felt that when the principles involved are once thoroughly comprehended their universal application will be appreciated, so that it will make no difference whether pig iron or gold bullion is offered for test. It may further be noted that a discussion of the theories underlying practical methods is placed under the caption "Practical Sampling," with the idea that no one can be a practical sampler unless he is capable of analyzing his methods. No attempt has been made to advocate any one method, but it is hoped that the analyses of all of the methods in use will show where each may be correctly and safely applied. The fact that it is possible to demonstrate the theoretical correctness of several methods indicates the invalidity of the claim that any single one of them is the standard.

## PART I. THEORETICAL CONSIDERATIONS UNDERLYING SAMPLING.

### PURPOSE OF SAMPLING.

The ultimate purpose of sampling may be said to be the establishment of the commercial or chemical value of a bulk of any material. As such a bulk is, in nearly every case, large and unwieldy, sampling is designed to furnish a small and readily handled part, in which the quantitative relations of the various constituents are the same as in the bulk, so that the percentage of any of its constituents may be ascertained and the value so obtained will apply to the bulk. The foregoing statements may be put into algebraic expression as follows:

Let  $W$  represent the weight of the bulk;  $N$  the weight of any given constituent in the bulk of which the percentage  $X$  is to be found; and let  $w$  represent the weight of the sample and  $n$  the weight of the constituent in the sample corresponding to  $N$  in the bulk. For correct sampling the following relations must be true:

$$\frac{N}{W} \cdot 100 = \frac{n}{w} \cdot 100 = X; \text{ or } \frac{W}{w} = \frac{N}{n}.$$

In practice it more frequently happens that instead of one bulk several must be sampled, the individual samples being combined into one, representative of the whole. It is self-evident that all the weight ratios of the individual bulks and the samples must be equal, or if we designate the weights of the bulks, as  $W_1, W_2, W_3, \dots, W_z$ , and the weights of the samples as  $w_1, w_2, w_3, \dots, w_z$ , the values for the common sample will be  $\frac{W_1}{w_1} = \frac{W_2}{w_2} = \frac{W_3}{w_3} = \dots = \frac{W_z}{w_z}$ ; and with the analogous designation for the contents,  $\frac{N_1}{n_1} = \frac{N_2}{n_2} = \frac{N_3}{n_3} = \dots = \frac{N_z}{n_z}$ .

### SAMPLES OF HOMOGENEOUS MATERIALS.

If the bulk of a material is homogeneous; that is, if throughout its mass the quantitative relations of its constituents are invariable, sampling becomes a simple operation, because any small part taken anywhere from the bulk constitutes a correct sample, or  $\frac{n}{w} \cdot 100 =$  constant, irrespective of location in the bulk.

**SAMPLES OF HETEROGENEOUS MATERIALS.**

With a heterogeneous material the problem of sampling becomes complicated, owing to the fact that the quantitative relations of its constituents vary from place to place in the bulk; from no single location may an exactly representative sample be obtained. Small parts of the whole must therefore be taken from regularly distributed locations in part of or throughout the bulk. The small parts may be called partial samples, none correctly representing the bulk, but each correctly representing a part of it. In the whole sample  $n$  is made up of the various contents of the partial samples, which may be designated as  $a, b, c, \dots z$ , or  $n=a+b+c+\dots z$ , and therefore if the sample is to be correct—

$$\frac{N}{W}.100 = \frac{a+b+c+\dots+z}{w}.100 = X.$$

**SOME LAWS OF PHYSICS PERTAINING TO SAMPLING.**

As the sampling of a homogeneous material is a simple operation and that of a heterogeneous material a complicated one, it behooves the metallurgist to know the laws by which a homogeneous material may be obtained or by which a heterogeneous material is produced, and may be avoided or minimized. It is now an established fact not only that the laws of solution pertain to the substances ordinarily known as solutions, but that the metallic alloys obey the same laws.

**MOLTEN ALLOYS.**

As regards the sampling of metallic metallurgical materials, the latter may be in either the liquid (molten) or the solid state. In the liquid state there is always a solution. It is well known that when a homogeneous solution of two or more substances is subjected to varying temperature in several parts of its volume heterogeneity, due to diffusion, ensues. In sampling, therefore, heterogeneous, as well as homogeneous, molten alloys may be encountered. Complete solution of the components, perfect mixture, and uniform temperature throughout the molten mass will cause homogeneity.

**SOLID ALLOYS.**

All the solid forms of metallic metallurgical materials that are encountered by the sampler have passed from the molten to the frozen or solid state. The molecular changes or molecular rearrangements that take place in the freezing process vary according to the nature of the components of the alloys.

## BAKHUIS ROOZEBOOM'S CLASSIFICATION OF BINARY-ALLOYS SOLUTIONS.

Bakhuis Roozeboom<sup>a</sup> has given in diagrammatic form all the possibilities for the simplest, or binary, solutions in which the components mutually dissolve in all proportions in the liquid state. His diagrams (figs. 1 and 2) are the so-called freezing-point diagrams from which important conclusions may be drawn regarding the heterogeneity of the solidified alloys. In the diagrams the temperatures are measured by the heights of the ordinates, and the composition of the binary alloy is determined by the lengths of the abscissas. The freezing points lie along the curves, the upper of which denotes the initial and the lower the final freezing.

Bakhuis Roozeboom shows seven diagrams (figs. 1 and 2), representing two kinds of solutions. A solution of the first kind (fig. 1, A, B, and C) comprises a liquid solution frozen to an uninterrupted

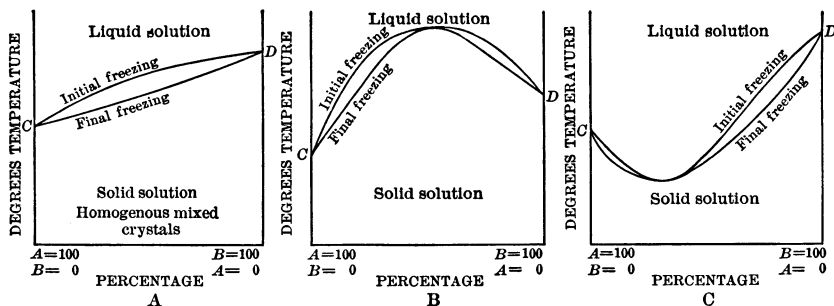

FIGURE 1.—Freezing-point diagrams of binary alloys in which the two substances are miscible in all proportions. *A* and *B*, pure substances; *C*, freezing point of pure substance *A*; *D*, freezing point of pure substance *B*.

series of mixed crystals. The main characteristic of such a solution is that before and after freezing there is only one phase; that is, the two substances are mutually soluble in all proportions in the liquid state and remain so after solidification; in the solid state a single phase only is present. There is diffusion during the act of cooling and freezing, as indicated by a successive range of freezing points, from the initial to the final freezing. There is, accordingly, a successive change of chemical composition of the freezing alloy and a consequent heterogeneity in the solid alloy without any segregation of its constituents that is visible under the microscope.

In the second kind of binary solution specified by Roozeboom the two substances in solution (*A* and *B* in fig. 2) are miscible in all proportions in the liquid state, but are immiscible or only partly miscible in the solid state. In figure 2, B, which represents two sub-

<sup>a</sup> Bakhuis Roozeboom, H. W., *Erstarrungspunkte der Mischkrystalle zweier Stoffe*: *Ztschr. phys. Chem.*, Bd. 30, 1899, p. 385.





point diagram shown in figure 3 illustrates the character of those binary alloys in which the two metals are no longer soluble in each other in all proportions in the liquid state at all temperatures, but

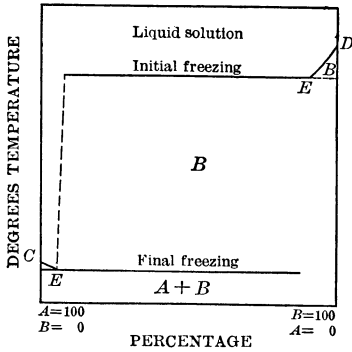

FIGURE 3.—Freezing-point diagram of binary alloys in which the two substances separate into two layers.

in which each may hold a small percentage of the other in solution at the freezing point. In the diagram are indicated two eutectic points, between which there may lie a wide range of temperature, depending on the difference of the freezing-point temperatures of the two metals. Most characteristic of this class of alloys is the property that when in the liquid state, and when their composition lies between that of the two eutectic points, they will, on cooling at some temperature below the highest freezing point, separate into two layers

of liquid, each of constant freezing point. Probably most of the metallo-metalloidal alloys belong to this class.

Finally, there are binary alloys in which the two metals enter into chemical combination, the chemical compound being soluble in both of the metals. Figure 4 shows a characteristic freezing-point diagram of this class. As in the previous class, there are two eutectic points, and between them a maximum point which is the freezing point of the pure chemical compound. This freezing point may be higher or lower than that of either metal, or it may lie between them.

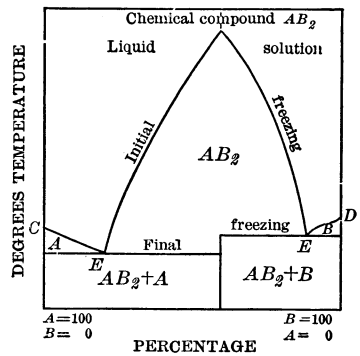

FIGURE 4.—Freezing-point diagram of two substances forming a chemical compound.

#### CONCLUSIONS FROM DISCUSSION OF BINARY-ALLOY CURVES.

From the foregoing review of the binary alloys as represented by their freezing-point curves there follow a number of important conclusions that have a special bearing on the homogeneity or heterogeneity of such materials as they offer themselves to the sampler. The one thing especially to be observed in each of the diagrams is that there are two separate freezing-point curves with varying ranges of temperature between them. The upper curve represents the temperature of the alloy that freezes first and the lower one the tem-

perature of the alloy that freezes last. Each successively freezing part of an alloy with successive change of freezing temperature must of necessity correspond to a change in chemical composition. Diffusion must result, and the final solid mass formed from the original homogeneous molten one is heterogeneous. It follows with certainty that where the two freezing-point curves are the farthest apart, or the range of the freezing temperature is greatest, there is also the greatest difference in chemical composition, the greatest degree of diffusion, and the greatest heterogeneity in the solidified alloy. Wherever the two freezing-point curves meet or intersect, or where there is only one freezing point of the alloy, the range of the freezing temperature is zero, there can be only one chemical composition during the course of solidification, there is no diffusion, and, consequently, the solidified alloy is homogeneous as viewed by the sampler. Two substances having freezing-point curves like those shown in figure 1, A, have the greatest range between the two curves when the two component metals are present in about equal proportions. The two curves meet at the points of the pure metals. This means that no one of the alloys of this series has only one freezing point, and that all of them freeze to a heterogeneous solid state, with the greatest degree of heterogeneity, in an alloy of about equal parts of the two metals. The gold-silver alloys are supposed to belong to this class. Regarding alloys such as those represented by the diagrams in figure 1, B and C, and in figure 2, there is for each a point where the two freezing-point curves meet or intersect, and where, therefore, there is only one freezing point for the corresponding alloy and where there is no diffusion, and, consequently, there is chemical homogeneity during the freezing as well as in the solid state of the alloy. Relative to such alloys as those represented in figure 3, there are two points of intersection of the two curves at which the range of freezing temperature is zero and at which the corresponding alloys will solidify to a homogeneous solid. Between the two points the composition and the freezing points of the two alloys remain constant, wherefor in the diagram these points lie in two parallel lines, and proceeding from either end of these the quantity of the one alloy increases and the other correspondingly decreases. They are called conjugate alloys.

As regards the formation of the alloys represented in figure 4, the conditions attendant on the formation of the alloys represented in figure 3 are repeated, but there is one more point with the range of the freezing temperature equal to zero. This point, as distinguished from the eutectic that is at the position in the curve representing minimum temperature, always occupies a position representing maximum temperature and indicates that the alloy at this point is a chemical compound. This, then, must not only be homogeneous in chem-

ical composition throughout its solidified mass, but it must show itself structurally homogeneous under the microscope, like an elementary metal or a solid solution. Many pairs of metals form more than one chemical compound, and their freezing-point curves show a corresponding number of points representing maximum and minimum temperatures.

It must now be clear that heterogeneity in alloys, as the main difficulty in their sampling, is chiefly dependent on the character of the alloy, such as expressed in the freezing-point diagrams, and it should be repeated that with the greatest range of freezing temperature the greatest degree of heterogeneity in the solid alloy must be expected. On the other hand, if the range of the freezing temperature is zero, or if there is only one freezing point, the solid alloy may be expected to be homogeneous. But the degree of heterogeneity or of diffusion is also dependent on other factors. As diffusion requires a measurable time, a rapid rate of cooling counteracts it. The rate of cooling may be increased by reducing the size of the castings and by casting into cold and heavy molds. Heterogeneity or diffusion may also be largely counteracted and minimized by stirring the molten alloy until its freezing temperature is reached or until solidification makes stirring impossible.

#### ERRORS OF OBSERVATION AND INTERPRETATION.

Metallic alloys do not offer the same advantage to the observer as the ordinary solutions, in which the constituents may be separated, in more or less pure form, in various ways. In the alloys generally the constituents remain closely intermingled, and as separation is rendered impossible, there can be no chemical analysis. Consequently, a large part of the present knowledge of the alloys has been gained by physical methods, such as by determining the freezing points with the pyrometer; by measuring the conductivity of heat and electricity, etc.; and by studying with the microscope etched surfaces to determine the character of their microstructure. It must be apparent that in the research of the alloys by these means the conclusions as to their chemical character are largely inferential. An example will make this clear. Stead<sup>a</sup> showed by "heat tinting" that what he had taken for iron carbide under the microscope was really iron phosphide. He says: "Other metallographers would probably find, on reexamining their specimens by the new methods, that what they had taken to be cementite was in reality phosphide of iron."

---

<sup>a</sup> Stead, J. E., Iron and phosphorus in steel: Jour. Iron and Steel Inst., vol. 2, 1900, p. 60.

It has been remarked that human nature inclines to see things not as they are, but as they are desired to be. In the copper-silver series of alloys the segregates are said to be the two elements, copper and silver, either pure or each containing in solid solution a small proportion of the other. Nothing of the kind has ever been proven by chemical analysis. We are further told that the freezing-point curve of this series is either according to that shown in figure 2, D, or in figure 2, B. If the two diagrams mentioned represent an actual condition, they indicate that from the copper end of the alloys series copper will freeze out first from the molten alloy and will continue to freeze first, or at least in greater quantity than silver, until the eutectic composition is reached, when the two metals or their solid solutions freeze simultaneously. The reverse must take place from the silver end of the series to the eutectic point. It further follows that whatever freezes first must freeze where the lowest temperature exists; this point can be only where the hot molten body transmits its heat to a colder surrounding medium, and this action, as a matter of course, must initially proceed along a part or over its whole surface. It is inconceivable that freezing will take place first at any point nearer the center, because the heat, without doubt, must be transmitted in measurable time from the center to the surface; the center, consequently, remains hotter than the surface until the whole has reached its equilibrium with the temperature of the surrounding medium. Roberts-Austen demonstrated with the pyrometer that there is a difference of many degrees between the temperature of the center and that of the surface of a block of hot metal of comparatively small dimensions.

As to the copper-silver alloys from 100 to 71.89 per cent copper there can be only one conclusion, provided the freezing-point diagram is correct and its interpretation true—that the bars of these alloys must be richer in copper toward the surface or enriched in silver toward the freezing center. But the fact is that from the time of the work of Levol<sup>a</sup> in 1852 up to the present<sup>b</sup> it has been found that these same alloys show an enrichment in silver toward the surface of the bars. It must plainly follow that where, according to the freezing-point diagram, copper should freeze first it is the silver or a compound rich in silver that freezes initially. Roberts<sup>c</sup> first called attention to these facts, but he refrained from giving any explanation of the conflicting observations. In technical practice,

---

<sup>a</sup> Levol, A., *Mémoire sur les alliages, etc.*: *Ann. chim. phys.*, sér. 3, t. 36, 1852, p. 194.

<sup>b</sup> Schüssler, E., *Ueber die ungleichmässige Zusammensetzung der Metall-Legirungen*: *Berg Hüttenm. Ztg.*, vol. 43, 1884, p. 163.

<sup>c</sup> Roberts, W. C., *On the liquation, etc., of certain alloys of silver and copper*: *Proc. Roy. Soc. London*, vol. 23, 1874-75, p. 48.

however, it has often been observed that in copper bullion the silver shows a high degree of enrichment toward the freezing center of the bars; and that with increased silver content and impurities, greater homogeneity results and sometimes enrichment in the parts near the surface takes place.

Such phenomena led to scientific investigations. Former experimenters in their researches had not covered copper-silver alloys of so low a silver content as is found in most copper bullions. Consequently this end of the series demanded some closer attention regarding the direction in which the silver in the course of freezing diffused in the bullion.

#### RESULTS OF SAMPLING LOW-GRADE COPPER-SILVER ALLOYS.

For experiments described below the purest commercial electrolytic copper was selected. This was melted under a charcoal cover

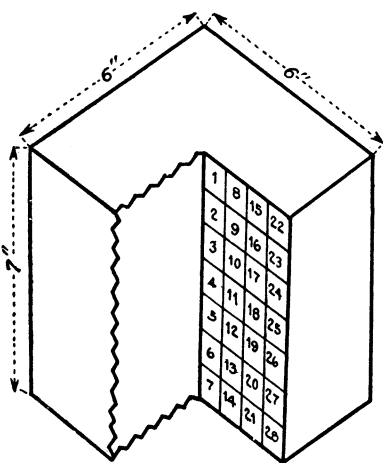

FIGURE 5.—Size of cube used in experiments with copper-silver alloys, showing where 28 samples were taken.

in a crucible, and for each succeeding test an additional amount of silver was added, the melt being thoroughly mixed, and a block of the alloys 6 by 6 by 7 inches being cast in a clay mold. Six different alloys were thus made, and five of them were drilled as indicated in figure 5. Four rows of holes were drilled through the block from top to bottom, each one inch in depth being made a separate sample, as indicated by the numbers 1 to 28. In the sixth the drill holes were put a little closer together and a fifth hole drilled closer to the side of the block. In each melt, after thorough mixing, a sample was shot (granulated)

from the crucible to permit the determination of the average content of silver in each alloy.

#### TABULATED RESULTS OF SILVER DETERMINATIONS.

Table 1, following, shows the results of determinations of silver in the six blocks of low-grade copper-silver alloys.

TABLE 1.—Results of determinations of silver in blocks of low-grade copper-silver alloys.

[Results represent ounces of silver in a ton of alloy. Sources of samples are shown in figure 5, except for block 6. For taking the samples from this block five holes were drilled, the holes being spaced closer together than the four holes drilled in the other five blocks.]

BLOCK 1. AVERAGE SILVER, 15.71.

| Sample No. | Silver content. | Sample No. | Silver content. | Sample No. | Silver content. | Sample No. | Silver content. |
|------------|-----------------|------------|-----------------|------------|-----------------|------------|-----------------|
| 1.....     | 19.16           | 8.....     | 17.42           | 15.....    | 15.76           | 22.....    | 15.45           |
| 2.....     | 14.03           | 9.....     | 13.88           | 16.....    | 13.89           | 23.....    | 14.44           |
| 3.....     | 16.00           | 10.....    | 15.75           | 17.....    | 15.25           | 24.....    | 14.80           |
| 4.....     | 22.96           | 11.....    | 18.08           | 18.....    | 15.80           | 25.....    | 14.95           |
| 5.....     | 21.69           | 12.....    | 16.61           | 19.....    | 16.29           | 26.....    | 15.59           |
| 6.....     | 13.89           | 13.....    | 13.62           | 20.....    | 16.43           | 27.....    | 14.24           |
| 7.....     | 15.08           | 14.....    | 15.64           | 21.....    | 16.65           | 28.....    | 15.32           |

BLOCK 2. AVERAGE SILVER, 29.00.

|        |       |         |       |         |       |         |       |
|--------|-------|---------|-------|---------|-------|---------|-------|
| 1..... | 28.80 | 8.....  | 29.05 | 15..... | 28.14 | 22..... | 28.11 |
| 2..... | 28.02 | 9.....  | 27.66 | 16..... | 28.00 | 23..... | 28.42 |
| 3..... | 29.41 | 10..... | 29.48 | 17..... | 29.39 | 24..... | 29.39 |
| 4..... | 29.80 | 11..... | 29.45 | 18..... | 29.08 | 25..... | 30.14 |
| 5..... | 30.42 | 12..... | 29.69 | 19..... | 28.92 | 26..... | 29.94 |
| 6..... | 30.80 | 13..... | 30.09 | 20..... | 28.77 | 27..... | 29.96 |
| 7..... | 29.01 | 14..... | 29.07 | 21..... | 28.46 | 28..... | 29.58 |

BLOCK 3. AVERAGE SILVER, 55.57.

|        |       |         |       |         |       |         |       |
|--------|-------|---------|-------|---------|-------|---------|-------|
| 1..... | 53.75 | 8.....  | 53.33 | 15..... | 55.63 | 22..... | 58.59 |
| 2..... | 53.93 | 9.....  | 53.35 | 16..... | 53.83 | 23..... | 53.75 |
| 3..... | 58.77 | 10..... | 58.17 | 17..... | 57.19 | 24..... | 55.83 |
| 4..... | 59.23 | 11..... | 59.01 | 18..... | 57.91 | 25..... | 57.01 |
| 5..... | 62.69 | 12..... | 58.75 | 19..... | 58.09 | 26..... | 58.53 |
| 6..... | 58.77 | 13..... | 57.81 | 20..... | 58.13 | 27..... | 58.67 |
| 7..... | 56.43 | 14..... | 56.95 | 21..... | 55.57 | 28..... | 55.45 |

BLOCK 4. AVERAGE SILVER, 168.85.

|        |        |         |        |         |        |         |        |
|--------|--------|---------|--------|---------|--------|---------|--------|
| 1..... | 166.58 | 8.....  | 168.78 | 15..... | 195.60 | 22..... | 177.20 |
| 2..... | 150.52 | 9.....  | 147.24 | 16..... | 140.62 | 23..... | 157.18 |
| 3..... | 163.74 | 10..... | 167.86 | 17..... | 157.34 | 24..... | 163.54 |
| 4..... | 183.66 | 11..... | 171.64 | 18..... | 165.64 | 25..... | 165.80 |
| 5..... | 181.88 | 12..... | 177.66 | 19..... | 173.04 | 26..... | 162.90 |
| 6..... | 175.74 | 13..... | 187.90 | 20..... | 176.52 | 27..... | 165.12 |
| 7..... | 170.52 | 14..... | 167.22 | 21..... | 162.38 | 28..... | 160.50 |

BLOCK 5. AVERAGE SILVER, 220.17.

|        |        |         |        |         |        |         |        |
|--------|--------|---------|--------|---------|--------|---------|--------|
| 1..... | 176.15 | 8.....  | 192.11 | 15..... | 223.47 | 22..... | 251.68 |
| 2..... | 201.46 | 9.....  | 182.01 | 16..... | 199.32 | 23..... | 244.19 |
| 3..... | 217.81 | 10..... | 217.15 | 17..... | 202.80 | 24..... | 206.85 |
| 4..... | 219.14 | 11..... | 215.26 | 18..... | 201.65 | 25..... | 210.27 |
| 5..... | 199.93 | 12..... | 197.43 | 19..... | 201.46 | 26..... | 220.49 |
| 6..... | 199.13 | 13..... | 200.53 | 20..... | 218.87 | 27..... | 244.77 |
| 7..... | 217.30 | 14..... | 213.49 | 21..... | 232.33 | 28..... | 210.12 |

BLOCK 6. AVERAGE SILVER, 317.64.

|        |        |         |        |         |        |         |        |
|--------|--------|---------|--------|---------|--------|---------|--------|
| 1..... | 270.32 | 10..... | 257.16 | 19..... | 302.06 | 28..... | 312.98 |
| 2..... | 261.52 | 11..... | 311.28 | 20..... | 295.78 | 29..... | 370.24 |
| 3..... | 265.86 | 12..... | 328.10 | 21..... | 316.64 | 30..... | 374.50 |
| 4..... | 301.72 | 13..... | 330.10 | 22..... | 378.06 | 31..... | 332.64 |
| 5..... | 356.60 | 14..... | 325.52 | 23..... | 427.40 | 32..... | 308.52 |
| 6..... | 324.26 | 15..... | 305.60 | 24..... | 309.02 | 33..... | 312.52 |
| 7..... | 347.78 | 16..... | 253.18 | 25..... | 301.50 | 34..... | 325.64 |
| 8..... | 284.74 | 17..... | 261.18 | 26..... | 315.28 | 35..... | 362.82 |
| 9..... | 259.36 | 18..... | 297.92 | 27..... | 305.34 |         |        |

## DISCUSSION OF TABULATED RESULTS.

The results presented in the table show that in block 1 only was there a very distinct concentration of the silver toward the center of the block, whereas in block 6 the phenomenon of diffusion was completely reversed; in that block the enrichment in silver along the outer parts was no less distinct than that toward the center in the first block. In the blocks between the two there was without doubt at some point complete homogeneity. These results lead to the conclusion that in the freezing-point diagrams, as established by Heycock and Neville<sup>a</sup> and by Friedrich and Leroux<sup>b</sup> (see fig. 2, B or D), the initial freezing-point line, from the point of pure copper to the eutectic point, a line shown as continuous and almost straight, can not be correct, because such a line would mean that the phenomena along that line are continuous and of the same order. However, it is known that somewhere in the beginning of the alloy series there is a reversal of the phenomenon of diffusion and that to this should correspond a kink in the curve, with either a maximum or a minimum point. Up to this point copper freezes first; the silver content ranging around 0.5 per cent. With 1.0 per cent of silver, the first freezing of this metal becomes distinct.

Evidently the freezing-point diagrams, as far as they have been worked out, are incomplete representations of the freezing process of the copper-silver alloys and, as a consequence, their interpretation, too, must be faulty. The results obtained by the chemical-analytical method are of a positive nature, and it would seem that physical methods need revision to insure greater completeness, by the use of more delicate instruments. Anything here offered in explanation must be purely hypothetical, but it would appear that if in the copper-silver series copper freezes first only until the alloy contains about 0.5 per cent of silver, additional silver forms a chemical compound with the copper, or a succession of compounds, on the order of the loose compounds of some hydrated salts.

## EXPERIMENTS OF HEYCOCK AND NEVILLE.

As analogous to the homogeneous copper-silver alloy with less than 0.5 per cent silver, Heycock and Neville's<sup>c</sup> tin-copper alloy with 0.915 per cent copper may be cited. In 1890 Heycock and Neville said of this composition: "When we start with an alloy of a concentration of 0.915 per cent copper in tin it solidifies to a mass in which the copper is uniformly distributed throughout the tin—a substance

---

<sup>a</sup> Heycock, C. T., and Neville, F. H., Complete freezing-point curves of binary alloys containing silver and copper, together with another metal: *Philos. Trans.*, vol. 189, 1896, p. A25.

<sup>b</sup> Friedrich, K., and Leroux, A., Kupfer, Silber, und Blei: *Metallurgie*, vol. 4, 1907, p. 297.

<sup>c</sup> Heycock, C. T., and Neville, F. H., The molecular weights of metals when in solution: *Jour. Chem. Soc. London*, vol. 57, 1890, p. 376.



which is mechanically homogeneous. It is difficult to see how a solution either stronger or weaker than this can solidify slowly and remain homogeneous."

By 1901 Heycock and Neville<sup>a</sup> had proved the inadequacy of the last part of their opinion, for they pointed out the existence of "an eutectic at 16 atomic per cent of tin; a chemical compound  $\text{Cu}_4\text{Sn}$ ; a chemical compound  $\text{CuSn}$ ; and an eutectic at 98 atomic per cent of tin." Of course, all four of these are mechanically homogeneous, and two of them, the chemical compounds, must also be structurally homogeneous.

**INVESTIGATIONS BY HEYN.**

Heyn<sup>b</sup> examined the solutions of copper suboxide in copper and found in the freezing-point curve a eutectic point at which the copper contained about 3.5 per cent of the suboxide. Heyn examined copper up to a content of 9 per cent of the suboxide, and he classed this solution with those represented in figure 2, D. This classification would mean that copper and its suboxide are miscible in all proportions in their molten state, and that they do not separate into two layers. However, such a separation is just what appears to take place in a furnace where molten copper is oxidized; the layer of copper constantly diminishes, and the layer of slag, rich in copper suboxide, increases, the molten copper never containing more than 10 per cent of suboxide. Heyn's freezing point diagram for an alloy of copper and copper suboxide is shown in figure 6. It would seem that the second part of Heyn's curve, which is very steep, would become discontinuous at about the end point indicated in the figure, and that the complete diagram would correspond to that of figure 3.

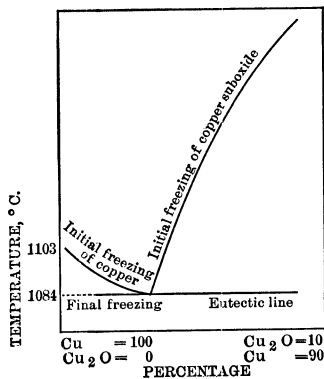

FIGURE 6.—Freezing-point diagram for an alloy of copper and copper suboxide.

**OBSERVATIONS BY HUNT.**

Hunt<sup>c</sup> called attention to the fact that "aluminum added to steel in the proportion of less than 1 per cent exerts a restraining influence on the segregation of phosphorus in large ingots." He says further:

My own suggestion as to the reason for this action is, that the aluminum causes the molten steel to solidify much more evenly. Steel with aluminum

<sup>a</sup> Heycock, C. T., and Neville, F. H., On the copper-tin alloys: Jour. Chem. Soc. London, vol. 69, 1901, p. 320.

<sup>b</sup> Heyn, E., Kupfer and Sauerstoff: Mitteil. Kgl. tech. Versuchsanstalten, vol. 18, 1900, p. 315.

<sup>c</sup> Hunt, A. E., The physics of steel: Trans. Am. Inst. Min. Eng., vol. 24, 1894, p. 771.

added to it does not "chill" at the surfaces of the mold and "freeze" toward the center, leaving, for a considerable period, a mass of molten "mother liquor," as it were, in the center of the ingot, as does ordinary metal. Steel with aluminum added to it, when the temperature is lowered to the solidifying point, seems to "freeze" altogether; and the needles of solidifying metal can be seen to dart across the whole surface of the top of an ingot, and the metal at the top of the surface of the ingot to become solid almost instantaneously, when the "freezing" operation once commences, although the metal, as a whole, seems to remain molten a longer time with aluminum added than metal similarly treated without the addition of aluminum. Segregation is in this way restrained by preventing the mass of metal in the interior of the ingot from remaining molten for a much longer time than that on the surface—which has been considered the physical reason of segregation.

Howe<sup>a</sup> pointed out the difficulty of comprehending Hunt's explanation, and he ably elucidated the impossibility of any mass of metal freezing "altogether." Hunt's example appears to be an instance of the modification of the saturation point of two substances by the addition of a third, or of the diffusibility of phosphorus in iron reduced by the addition of aluminum.

#### EXAMPLE OF INCOMPLETE INTERPRETATION.

An instance of incomplete interpretation relative to solid solutions is cited below. It has been stated that some substances separate from solution in the liquid state, forming two layers, that others separate at their freezing point, forming an intimate solid mixture, and that still others remain in solid solution after freezing, the last class being covered by the Roozeboom diagrams shown in figure 1. When, however, the question is asked, what constitutes solution, it may be defined as the mutual continued diffusion of two substances. Diffusion means molecular motion, with consequent pressure (osmotic). Heat also means motion, but at the absolute zero of temperature there is no longer such motion. Therefore, as a solution approaches the absolute zero it must lose the character of a solution and must cease to be one. Or in the descending scale of temperature from a point at which all substances are perfectly miscible a point must be reached where the substances of every solution (alloy) will separate or segregate. Theories of solution have hitherto taken into account ordinary temperatures only, and it is, of course, impossible to give experimental proof for temperatures approaching the absolute zero.

#### TERMINOLOGY OF SAMPLING.

##### "SEGREGATION" AND "LIQUATION."

In the literature on alloys and on the sampling or assaying of these metallic materials, the terms "segregation" and "liquation" are

---

<sup>a</sup> Howe, H. M., The physics of steel: Proc. Am. Inst. Min. Eng., vol. 24, 1894, p. 771.

frequently used indiscriminately to designate the heterogeneity existing in them. There is chaos and confusion in this particular nomenclature, although Howe<sup>a</sup> seems to be the only metallurgist and writer who has keenly felt it and has attempted to obviate it. He says: "For convenience I use 'segregation' to designate a concentration inwards, and 'liquation' to designate an expulsion of matter outwards from the interior of the mass, but without insisting on the propriety of this terminology."

Webster's dictionary gives the following definitions: "Segregate, to separate, to part," and "liquate," in the metallurgical sense, "to separate an easily fusible metal from one less fusible." Percy<sup>b</sup> says: "When an ore or metallic mixture containing ingredients differing sensibly in fusibility is exposed to a degree of heat sufficient only to melt the most fusible which may flow away from the unmelted mass, this process is termed liquation."

Clearly, therefore, "liquate" is essentially a technical term and confined to certain phenomena and operations in metallurgy. These, however, are capable of scientific definition and are defined subsequently.

As mentioned above, Howe used "segregation" to designate centripetal concentration in the mass of an alloy, and "liquation" to designate centrifugal concentration in the alloy. If the distribution of a single element, or metal, among others is viewed Howe's system may appear rational; when, however, the whole phenomenon is considered, it is found that in a binary alloy the movements of the two metals are interdependent. The outward movement of the one is coincident with the inward movement of the other; the direction of the diffusion is determined by the relative mass of the two metals. Clearly, therefore, in one phenomenon there is both centripetal and centrifugal motion, supposed to be caused by osmotic pressure, and entirely independent of gravity or the forces of crystallization. In the alloys covered by figure 1, all this takes place, but there follows no "segregation," if the word is used in its implied meaning that the metals actually "separate" from mutual solution on freezing. There is certainly no "liquation," for no two substances of different fusibility separate and flow under the influence of gravity. It would seem that to the heterogeneity thus resulting from diffusion one or the other of the following definitions might be applied: "Concentration inward and outward," "centripetal and centrifugal concentration"; or, for the first, simply "concentration," and for the latter "dispersion."

The alloys covered by the diagrams shown in figure 2 show the same diffusion phenomena as those discussed above, and the same

---

<sup>a</sup> Howe, H. M., *Metallurgy of steel*, 1904, p. 203.

<sup>b</sup> Percy, John, *Metallurgy*, London, 1875, p. 46.

terminology should be applied to the mere heterogeneity of chemical composition, as evinced by sampling. However, when diffusion has taken place, another phenomenon, independent of diffusion, ensues. It is the separating of a solid mixture out of solution of the metals or of mixed crystals, as they reveal themselves to the vision under the microscope. It would seem that the term "segregation" should be applied to the latter characteristic alone, a characteristic that chiefly concerns the metallographer but has little bearing on sampling.

The inconsistency of the old terminology is most strikingly illustrated in the alloys of eutectic composition. In these there is no diffusion, yet the greatest degree of segregation, or separating out of the metals, is revealed in their microstructure. They are structurally heterogeneous, yet by the regular methods of sampling they reveal complete homogeneity in chemical composition.

In the two classes of alloys just reviewed diffusion results in a heterogeneity that is gradual and continuous in the solidified mass, gravity probably playing only a small part in the distribution of the constituents through convection currents. In the third class of alloys, covered by figure 3, there is also diffusion, followed by segregation in the molten state, the segregation being so great that in the distribution of the resulting molecular aggregates gravity is the chief factor. The segregated or liquated parts in these alloys differ radically in chemical composition, there being no transition from one to the other.

#### EXAMPLE OF NEED OF DEFINITE TERMS.

As illustrative of the foregoing discussion may be cited the results of experiments with copper-lead alloys, which are characteristic of the class of alloys last mentioned: A copper-lead bullion plate, 6 by 8 by 1 inches, with a lead content of 3.85 per cent, and a silver content of 81 ounces per ton, was placed in a horizontal position in a muffle at a temperature of low-red heat. It was noticed that drops of a liquid metal (lead) soon began to sweat out. They were collected as carefully as possible, and the assay of them showed a silver content of 635.5 ounces per ton. The plate was then oxidized to the depth of one-sixteenth of an inch, and the oxide scales were detached by plunging the red-hot plate into water. The silver content of the oxide, figured on the basis of metal, was 102.7 ounces per ton. Oxidations under the same conditions were repeated, and the lowest silver content (on the basis of metal) was 69 ounces per ton. The silver content of the original plate throughout its thickness varied between 80 and 86 ounces per ton. These figures indicate that liquation took place. It would appear appropriate to confine the term "liquation" to the phenomena of this class of alloys alone.

**“SOLVENT” AND “SOLUTE.”**

Solutions are almost universally said to be composed of the dissolving substance, or “solvent,” and the dissolved substance, or “solute.” These definitions may be fairly consistent for dilute solutions; or when the solvent is a liquid and the solute is a solid; or for such solutions as are represented in figure 3, in which either metal takes up only a small quantity of the other. However, the definitions do not apply so well to alloys of the eutectic composition as those represented in figure 2, B, C, and D. Such an alloy, consisting of the two metals *A* and *B*, is at the same time a saturated solution of *B* in *A* and of *A* in *B*, and it is impossible to determine which of the two is the solvent or which the solute; they are mutually dissolved, or dissolved in each other.

**“HYPOEUTECTIC” AND “HYPEREUTECTIC.”**

In the chemistry of steel there have been introduced the terms “hypo-eutectic” and “hyper-eutectic” to designate the composition of the steel below or above the eutectic composition. As to their application to alloys in general the following may be said: In considering the curves of the alloys with one eutectic point there is, at the beginning of the curve for either metal, a hypo-eutectic that continues until the point representing the eutectic is reached, but as this point is passed with one metal the hypo-eutectic composition of the other metal is entered. Therefore there are no hyper-eutectic alloys of this kind. The term may, however, be appropriately applied to the class of alloys with two eutectic points in which each of the two metals freezes with an excess of the other metal above the eutectic composition whenever the composition of the molten alloy lies between the two eutectics.

**“ALLOYS” AND “BULLIONS.”**

Scientifically, one speaks of alloys or metallic solutions; technically and commercially, one speaks of alloys and bullions. Bullions are always alloys, but the term implies that part of the constituents are precious metals.

The almost universal custom of designating as alloys all those metallic materials that are not elementary metals may be well justified scientifically, provided that they are classified systematically; as for example, according to freezing-point diagrams. The alloys may be binary, ternary, etc., or some of them may be chemical compounds, but no whole-alloy series can be composed of chemical compounds. In these series the chemical compounds play the same rôle as metallic elements. For example, figure 4 may be divided into two diagrams by a vertical line through the maximum point of the curve; each of

the two diagrams will then have the same character as the diagram of figure 2, D. Moreover, all the binary-alloy series, when viewed as solutions and through a sufficient range of temperature, have one identical characteristic; that is, at sufficiently high temperatures the constituents completely dissolve in each other and at a sufficiently low temperature they completely segregate. The last statement, however, is a theoretical inference only.

In practical metallurgy the castings of metals and alloys, or bulions, are known under several names, according to their shapes or relative dimensions; for example, a casting comparatively thick will be an ingot, a bar, or a pig; one that is thin will be a plate, a cake, or a slab. There appears to be no logical distinction in the application of these names.

## PART II. PRACTICAL SAMPLING.

### PRACTICABILITY OF MAKING HOMOGENEOUS ALLOYS.

It has been pointed out that the sampling of homogeneous materials is simple. The chemical analysis or assay of any small part of a given bulk of homogeneous material determines its value. The production of homogeneous alloys seems to be common practice in the Government mints and assay offices, where gold-bullion bars, which are also the sample bars, are made approximately homogeneous by remelting and refining. In other fields the practice of refining sample bars has been rejected, for the reason that in the process there are always unaccounted losses. However, the possibility of making homogeneous bars of the bulk of the materials in their production at the smelteries, thereby eliminating the possibilities of errors in sampling, should offer some attraction, especially in view of the skepticism with which various methods of sampling heterogeneous materials have been viewed in the past.

As mentioned previously, earlier experimenters found the only homogeneous copper-silver alloy to be that of the eutectic point, with 71.89 per cent copper and 28.11 per cent silver. This fact of itself would be of little avail in the transforming, on a commercial scale, of copper bullion of less than 1 per cent silver into homogeneous bars. Closer examination of copper-silver alloys revealed the fact that those with 0.1 to 0.5 per cent silver showed approximate homogeneity, and it was further noticed that the heterogeneity in silver content of copper-bullion bars was considerably modified—increased or decreased—by the presence of other metallic and metalloid impurities. However, because of the cost, the making of a homogeneous bullion by adding silver or other metals is entirely out of the question. There remain, however, the elements present in the process of producing copper—the sulphide of copper and atmospheric oxygen.

#### EXPERIMENTS BY THE AUTHOR.

Experiments made by the author showed that when to the ordinary gas-finished converter copper a metal such as lead or zinc was added in the proportion of about 2 per cent, the great heterogeneity in the silver content disappeared in the recast bars or blocks. The char-

acter of the blocks used in the experiments is shown in figure 7. They were 9 by 10 by 5 inches in thickness, and samples were obtained by drilling through their centers from top to bottom, each inch in depth being made a separate sample.

## TABULATED DATA.

The results of the experiments are shown in Table 2 following:

TABLE 2.—*Results of determinations of distribution of precious metals and impurities in blocks of copper bullion.*

[Locations of samples in block are indicated in figure 7.]

## A. BLOCK OF CONVERTER COPPER, GAS-FINISHED.

| Sample No. | Ag per ton. | Au per ton. | Pb.       | Bi.       | Sb.       | As.       | Te and Se. |
|------------|-------------|-------------|-----------|-----------|-----------|-----------|------------|
|            | Ounces.     | Ounces.     | Per cent. | Per cent. | Per cent. | Per cent. | Per cent.  |
| 1.....     | 76.7        | 0.28        | 0.0133    | 0.0032    | 0.0431    | 0.0240    | 0.0120     |
| 2.....     | 131.5       | .38         | .0310     | .0056     | .0744     | .0440     | .0208      |
| 3.....     | 159.2       | .42         | .0548     | .0076     | .1321     | .0708     | .0370      |
| 4.....     | 89.2        | .32         | .0156     | .0054     | .0545     | .0275     | .0166      |
| 5.....     | 52.3        | .24         | .0024     | .0012     | .0285     | .0137     | .0062      |

## B. BLOCK OF CONVERTER COPPER; CUPROUS SULPHIDE ADDED

| Sample No. | Ag per ton. | Au per ton. | Pb.       | Bi.       | Sb.       | As.       | Te and Se. | S.      |
|------------|-------------|-------------|-----------|-----------|-----------|-----------|------------|---------|
|            | Ounces.     | Ounces.     | Per cent. | Per cent. | Per cent. | Per cent. | Per cent.  | Per ct. |
| 1.....     | 99.2        | 0.26        | 0.0016    | 0.0016    | 0.0226    | 0.0133    | 0.0103     | 0.34    |
| 2.....     | 98.1        | .26         | .0029     | .0018     | .0234     | .0126     | .0091      | .52     |
| 3.....     | 102.3       | .28         | .0025     | .0025     | .0218     | .0159     | .0102      | .56     |
| 4.....     | 77.4        | .26         | .....     | .0037     | .0135     | .0104     | .0072      | .61     |
| 5.....     | 78.3        | .26         | .0010     | .0009     | .0151     | .0110     | .0070      | .65     |

## C. BLOCK OF CONVERTER COPPER; MORE CUPROUS SULPHIDE ADDED.

|        |      |      |        |        |        |        |        |       |
|--------|------|------|--------|--------|--------|--------|--------|-------|
| 1..... | 80.2 | 0.20 | 0.0016 | 0.0011 | 0.0291 | 0.0094 | 0.0064 | 1.088 |
| 2..... | 84.5 | .24  | .0078  | .0012  | .0309  | .0123  | .0070  | 1.338 |
| 3..... | 87.8 | .22  | .0073  | .0015  | .0289  | .0127  | .0052  | .753  |
| 4..... | 88.3 | .24  | .0076  | .0015  | .0313  | .0136  | .0045  | .735  |
| 5..... | 87.4 | .26  | .0089  | .0013  | .0353  | .0113  | .0054  | .779  |

## D. BLOCK OF REFINED CONVERTER COPPER.

| Sample. | Ag per ton. | Au per ton. | Pb.       | Bi.       | Sb.       | As.       | Te and Se. | O.      |
|---------|-------------|-------------|-----------|-----------|-----------|-----------|------------|---------|
|         | Ounces.     | Ounces.     | Per cent. | Per cent. | Per cent. | Per cent. | Per cent.  | Per ct. |
| 1.....  | 67.0        | 0.30        | 0.0088    | 0.0022    | 0.0377    | 0.0202    | 0.0078     | 0.327   |
| 2.....  | 70.7        | .28         | .0057     | .0020     | .0326     | .0216     | .0108      | .313    |
| 3.....  | 67.9        | .26         | .0080     | .0018     | .0225     | .0212     | .0082      | .297    |
| 4.....  | 63.2        | .26         | .0130     | .0014     | .0244     | .0169     | .0050      | .287    |
| 5.....  | 64.3        | .26         | .0069     | .0020     | .0304     | .0163     | .0072      | .270    |

## E. BLOCK OF REFINED CONVERTER COPPER, WITH CUPROUS OXIDE ADDED.

|        |      |      |        |        |        |        |        |       |
|--------|------|------|--------|--------|--------|--------|--------|-------|
| 1..... | 73.0 | 0.32 | 0.0090 | 0.0011 | 0.0227 | 0.0151 | 0.0049 | 1.447 |
| 2..... | 72.8 | .32  | .0064  | .0012  | .0207  | .0173  | .0077  | 1.247 |
| 3..... | 76.6 | .34  | .0039  | .0012  | .0277  | .0186  | .0079  | .648  |
| 4..... | 78.1 | .34  | .0027  | .0011  | .0245  | .0181  | .0082  | .816  |
| 5..... | 76.7 | .34  | .0031  | .0014  | .0269  | .0186  | .0085  | .975  |



TABLE 2.—Results of determinations of distribution of precious metals and impurities in blocks of copper bullion—Continued.

F. BLOCK OF STEEL.

| Sample No. | Carbon.          | Phosphorus.      | Sulphur.         | Manganese.       |
|------------|------------------|------------------|------------------|------------------|
|            | <i>Per cent.</i> | <i>Per cent.</i> | <i>Per cent.</i> | <i>Per cent.</i> |
| 1.....     | 0.270            | 0.0709           | 0.140            | 0.298            |
| 2.....     | .306             | .0531            | .169             | .354             |
| 3.....     | .305             | .0335            | .097             | .374             |
| 4.....     | .308             | .0748            | .138             | .393             |
| 5.....     | .330             | .0759            | .116             | .351             |

COMMENTS ON TABULATED DATA.

Table 2, section A, gives results showing the distribution of precious metals and impurities in a block of gas-finished converter copper; all the elements showed a high degree of concentration in the central parts of the block, which were the parts that froze last. The sulphur and oxygen contents are not given, because what remained of those elements in the solidified bullion was only a remnant of the proportions that played an important part in the diffusion phenomena of the freezing process, when the greater part escaped in the form of gaseous sulphur dioxide, giving rise to the name "gas finished." From 0.1 to 0.2 per cent of sulphur generally remained in the form of sulphide.

In this grade of bullion the concentration of all the foreign elements seems greater than in any of the other crude coppers. The reason has not been scientifically established, but the concentration may be due to one of two causes—the sulphur dioxide may render these elements more soluble in copper, or it may be more soluble in the copper than the other elements, and, therefore, depress the freezing point of that metal to a greater degree than do the other elements, thus retarding solidification and allowing greater time for diffusion.

In sections B and C of Table 2 are shown the effects of adding copper sulphide to gas-finished converter copper as regards the concentration of the various constituents. Section B shows that the concentration of silver and all the rest of the impurities of the

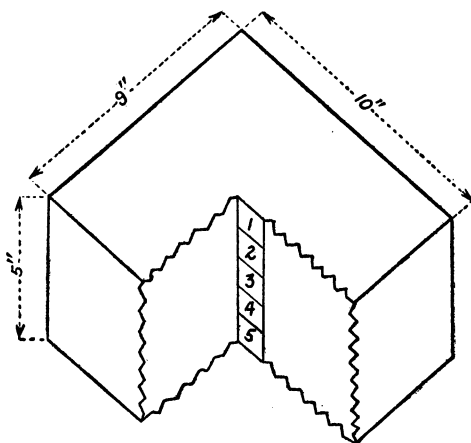

FIGURE 7.—Character of blocks of copper bullion and of steel used in experiments to show diffusions in alloys. Numbers indicate where samples were taken.

bullion was greatly reduced, and section C shows that with the copper sulphide content further increased the silver concentrated outward. The logical conclusion is that the admixture of a sulphide content of the proper proportion would produce a material that would be homogeneous from the viewpoint of the sampler.

The sulphur, or sulphide, distribution in the copper blocks, as shown in sections B and C of Table 2, may further serve to show the difference between distribution by diffusion and by liquation. Section B shows that the sulphur content constantly increased from the top to the bottom of the block, and as the copper sulphide is lighter than the copper the former could go to the bottom only by force of diffusion. Section C shows that the copper sulphide was carried to the top of the block by gravity; in fact, this block showed the beginning of separation into two layers, copper saturated with sulphide and sulphide saturated with copper.

Sections D and E of Table 2 show that what has been demonstrated for the cuprous sulphide can be accomplished also by cuprous oxide. This is present in furnace-refined copper to some extent, and section D of the table shows that in the experiments the concentration of the silver was much reduced as compared with that in the crude converter copper, whereas in the samples represented in section E, with the amount of copper suboxide greatly increased, the silver was dispersed. Thus there undoubtedly exists a suboxide content at which the homogeneity of the silver content is complete. The results of the experiments clearly indicate that the metallurgist can produce from his copper matte in the converter an approximately homogeneous copper bullion, either by underblowing or overblowing his charge.

Figure 8 shows the results of assaying a bar of gas-finished converter copper cast in the formerly customary pig form and indicates the great degree of heterogeneity that may exist in such a bar. Figure 9 shows a bar of copper bullion in similar pig form, unintentionally brought to approximate homogeneity by being produced in a blast furnace and in its molten state saturated with copper sulphide and other impurities. The impurities in the two kinds of bullion were as follows:

*Results of analyses of copper bullion.*

| Constituent.         | Gas-finished converter copper. | Blast-furnace black copper. | Constituent.                | Gas-finished converter copper. | Blast-furnace black copper. |
|----------------------|--------------------------------|-----------------------------|-----------------------------|--------------------------------|-----------------------------|
| Iron.....per cent..  | 0.1670                         | 1.1378                      | Arsenic.....per cent..      | 0.0150                         | 0.2055                      |
| Zinc.....do.....     | .0158                          | .....                       | Tellurium.....do.....       | .0067                          | Trace.                      |
| Cobalt.....do.....   | .....                          | .1376                       | Selenium.....do.....        | .0106                          | Trace.                      |
| Nickel.....do.....   | .0376                          | .1717                       | Sulphur.....do.....         | .3068                          | .8100                       |
| Lead.....do.....     | .0943                          | .1105                       | Silver.....ounces per ton.. | 12.00                          | 11.07                       |
| Bismuth.....do.....  | .....                          | .2435                       | Gold.....do.....            | .25                            | .11                         |
| Antimony.....do..... | .0153                          | .0689                       |                             |                                |                             |

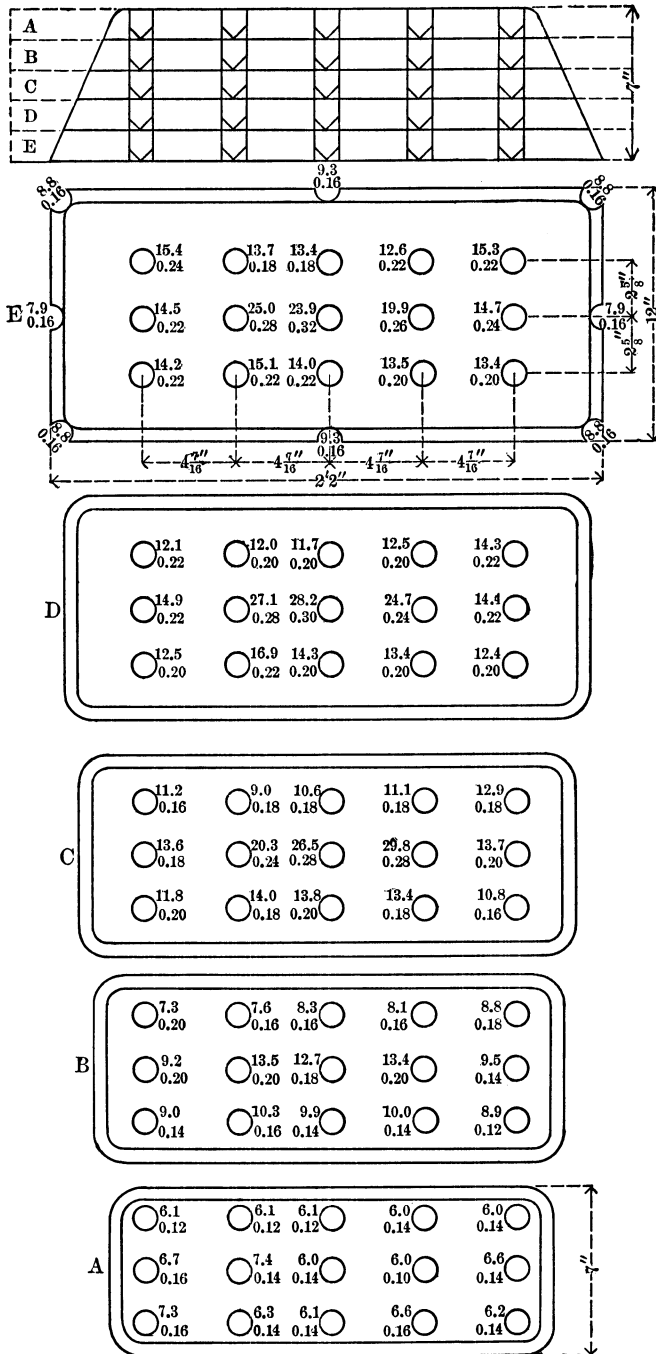

FIGURE 8.—Distribution of silver and gold in bar of gas-finished converter copper. For each drill hole the upper figure denotes gold content and the lower figure the silver content, in ounces per ton.

It is evident that the silver content was almost identical in the two kinds of copper bullion, and that the diffusion of the silver in

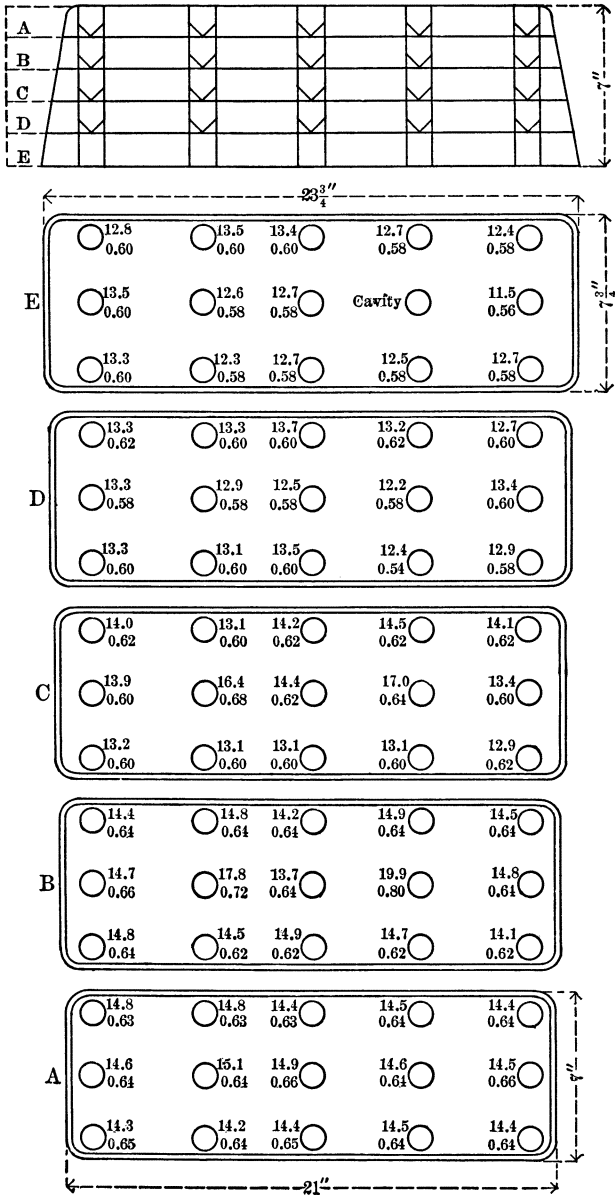

FIGURE 9.—Distribution of silver and gold in bar of black copper. For each drill hole the upper figure denotes silver content and the lower figure the gold content, in ounces per ton.

the copper was modified by the quantitative contents of the other elements. Copper in the one constituted more than 99 per cent, and in the other about 97 per cent.

### METHODS OF CONTROLLING DIRECTION OF DIFFUSION IN AN ALLOY.

That the direction of diffusion of several elements in an alloy may be reversed at will by increasing the quantity of one of them or by the addition in sufficient quantity of a new constituent may be demonstrated not only with copper bullion, as in the examples given above, but also with steel or other alloys. Howe<sup>a</sup> gives numerous examples showing that in low carbon steel the elements carbon, phosphorus, sulphur, etc., concentrate strongly toward the parts of the ingot that freeze last. The author was unable to melt such steel, but small pieces, after extended exposure to a high temperature under charcoal cover and in a graphite crucible, became fusible, by having their melting points lowered through the admission of carbon by diffusion. The pieces could then be cast into a block like that shown in figure 7. Each block so made was drilled through its center to give five samples, the results of analyses of which are given in Table 2, F, which shows that none of the elements named, with the exception of manganese, concentrated toward the freezing center; in fact, phosphorus and sulphur showed the phenomenon of dispersion to a marked degree.

The theory of the phenomenon of varying degrees of diffusion of any element in the presence of others may be briefly stated as follows: A metal saturated at its freezing point with another metal forms an alloy that is homogeneous from the viewpoint of the sampler. A metal subsaturated with another metal and producing a heterogeneous solid may be saturated with a third metal (metalloid or metallic compound) and two or all of them may freeze to a homogeneous mass. This statement is in harmony with the physico-chemical theory of concentrated solutions as enunciated by Jones,<sup>b</sup> according to which the saturation point of two substances may be greatly modified by the admixture of a third.

### SAMPLING MOLTEN FURNACE CHARGES.

The conditions under which a molten mass of an alloy may be homogeneous or heterogeneous have been set forth in Part I of this report. To sample a homogeneous mass it suffices to take one sample of any part of that mass, because, as has been pointed out, the one sample will correctly represent the whole mass. However, it is of prime importance to remember how readily homogeneity may be disturbed and how readily, as a consequence, a sample may fail to be representative of the whole mass sampled.

A sample from a molten charge must be taken by dipping it from the furnace with a ladle or by cutting it from the outflowing stream of

<sup>a</sup> Howe, H. M., *Metallurgy of iron and steel*, 1914.

<sup>b</sup> Jones, H. C., On the nature of concentrated solutions of electrolytes, etc.: *Am. Chem. Jour.*, vol. 31, 1904, p. 303.

the charge. If the dipping ladle has not the same temperature as the molten material, differentiation in the temperature of the molten sample, as well as in the proportions of the constituents in the various parts of its mass, will at once set in and the differences in the parts will become more marked as part of the sample freezes in the ladle. A shotted (granulated) sample thus poured from a ladle will, accordingly, become enriched or impoverished in the contents of the metal or metals sought, depending on whether the molten charge has been subsaturated or saturated with the metal or metals.

### RESULTS OF TESTS.

Wraith<sup>a</sup> has published results of tests made with a view of determining how the content of silver in copper bullion shotted samples could be influenced by the partial chilling of the ladle charge before the pouring of the shotted sample. Some of his results, with those obtained by the author, are embodied in Table 3 following:

TABLE 3.—Results of sampling copper bullion by pouring shotted samples from ladle compared with assays of skull and stream samples.

| Designation of sample.     | Kind of bullion.                       |   |                     |   |                     |                  |                                       |                     |
|----------------------------|--|---|---------------------|---|---------------------|------------------|---------------------------------------|---------------------|
|                            | Con-<br>verter<br>copper. <sup>a</sup> | Converter copper,<br>silver added. <sup>b</sup> |                     | Converter copper, silver and<br>arsenic added. <sup>b</sup> |                     |                  | Blast-furnace<br>copper. <sup>b</sup> |                     |
|                            | Silver,<br>per ton.                    | Weight<br>of<br>sample.                         | Silver,<br>per ton. | Weight<br>of<br>sample.                                     | Silver,<br>per ton. | Arsenic.         | Weight<br>of<br>sample.               | Silver,<br>per ton. |
|                            | <i>Ounces.</i>                         | <i>Grams.</i>                                   | <i>Ounces.</i>      | <i>Grams.</i>   | <i>Ounces.</i>      | <i>Per cent.</i> | <i>Grams.</i>                         | <i>Ounces.</i>      |
| Shot sample 1.....         | 75.85                                  | 310   | 453.54              | 1,002   | 728.01              | 2.67             | 483                                   | 116.22              |
| Shot sample 2.....         | 77.11                                  | 348   | 456.07              | 318   | 732.23              | 2.52             | 415                                   | 115.07              |
| Shot sample 3.....         | 78.40                                  | 331   | 464.28              | 380   | 737.10              | 2.75             | 585                                   | 112.50              |
| Shot sample 4.....         | 81.44                                  | 445   | 454.20              | 400   | 735.26              | 2.62             | 525                                   | 122.42              |
| Shot sample 5.....         | .....                                  | 432   | 459.16              | 433   | 735.71              | 2.73             | 1,057                                 | 122.45              |
| Shot sample 6.....         | .....                                  | 131   | 478.47              | 545   | 736.89              | 2.54             | 312                                   | 127.50              |
| Shot sample 7.....         | .....                                  | 719   | 504.70              | 1,058   | 772.77              | 2.68             | .....                                 | .....               |
| Skull sample.....          | 73.35                                  | 10,642  | 441.37              | 9,508   | 717.73              | 2.57             | 10,245                                | 117.24              |
| Average <sup>c</sup> ..... | .....                                  | .....   | 447.34              | .....   | 725.48              | .....            | .....                                 | 117.77              |
| Total.....                 | .....                                  | 13,519  | .....               | 13,644  | .....               | .....            | 13,622                                | .....               |
| Stream sample.....         | 74.99                                  | .....   | 448.24              | .....   | 727.23              | .....            | .....                                 | 164.18              |
| Copper, per cent. ....     | 99.30                                  | .....   | 98.02               | .....   | 94.48               | .....            | .....                                 | 87.83               |

<sup>a</sup> Results obtained by Wraith (see Wraith, William, sampling anode copper: Trans. Am. Inst. Min. Eng., vol. 41, 1910, p. 318.)

<sup>b</sup> Results obtained by author.

<sup>c</sup> Values for averages are for shot samples and for skull samples according to their weights.

The results showing average in the table are for the shotted samples and the ladle skulls, according to their weights. They should be identical with the results of the stream sample, if the charges were

<sup>a</sup> Wraith, William, Sampling anode copper; Trans. Am. Inst. Min. Eng., vol. 41, 1910, p. 318.

homogeneous. Figure 10 conveys an idea of how the ladle skulls were drilled for samples. Without doubt the samples obtained by

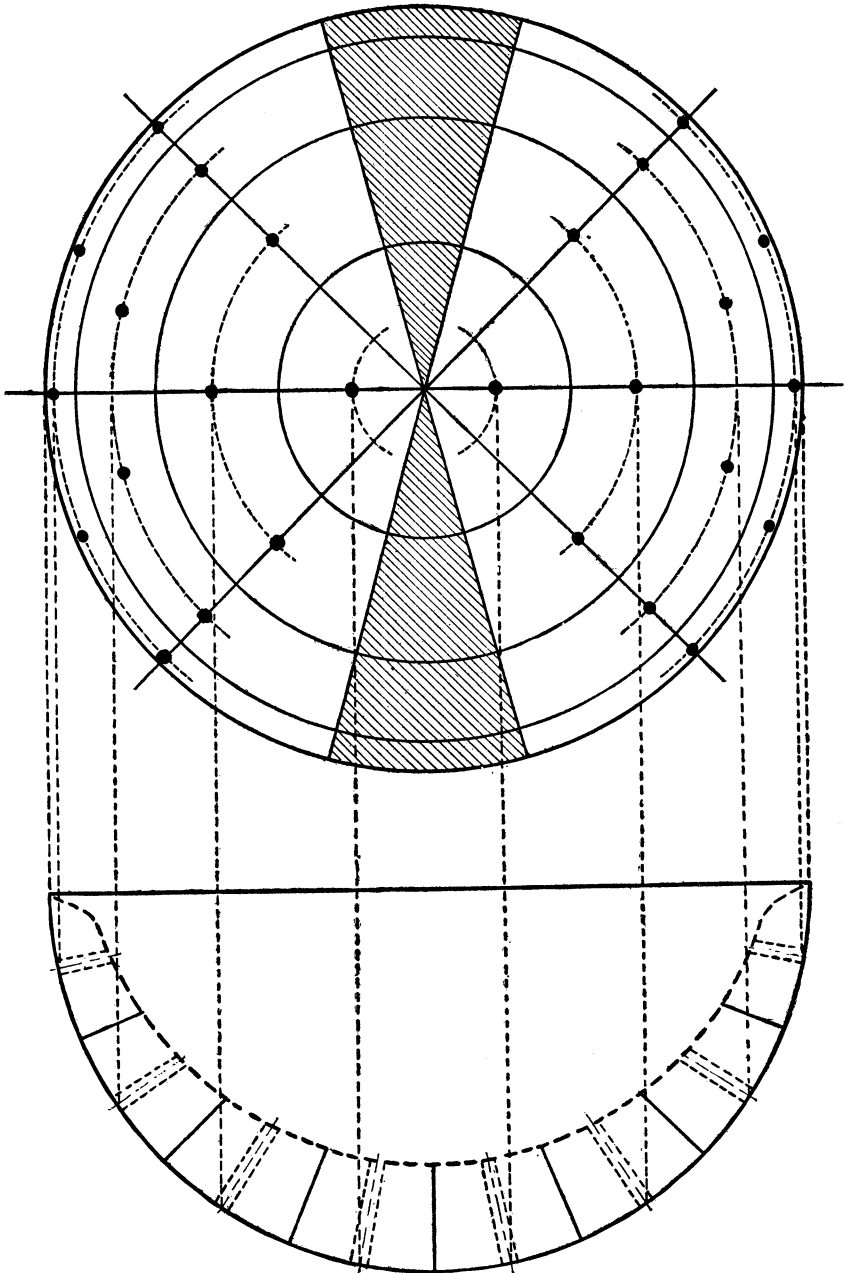

FIGURE 10.—Templet used in drilling skulls for samples.

this method were fairly approximate, and to have obtained a theoretically accurate sample it would have been necessary to completely

reduce to sawings such sectors as are shaded in the figure. In the shotting tests at the blast furnace the ladle sample and the stream sample were taken at intervals of less than 10 minutes. The two samples showed a wide divergence in silver content, demonstrating a corresponding change in the furnace charge during that brief space of time. Unless shotted samples are "batted" from the stream at the time each bar is cast it is certain that sampling by drilling each of the bars would give more accurate results. Clearly, shot sampling by pouring the molten bullion from a ladle is incompatible with accuracy and it should be barred from commercial practice.

#### SAMPLING MOLTEN STREAM OF METAL.

The only alternative method of sampling a molten charge of bullion is by cutting the sample from the stream of metal as it runs from the furnace. The question here is whether the stream remains homogeneous in its course after leaving the furnace. Wraith<sup>a</sup> inquired into this question and answered it in the affirmative. His test, however, stands alone, and it is no certain criterion that with other dimensions and temperatures the liquid stream would not show heterogeneity. The importance of considering this possibility will be apparent from a consideration of the simplest case—a stream of circular cross section forming a continuous cylinder, the cylinder being surrounded by a heat conducting medium of a temperature lower than its own, and the temperature being uniform around the whole surface of the stream. The heat from the stream consequently flows equally in the direction of every radius of its cross section, so that there is a rising temperature from the surface to the center, and a continuously varying chemical composition in the stream in the same direction.

#### TWO METHODS OF SAMPLING MOLTEN STREAM OF METAL.

How is such a stream to be cut for a correct sample? There seem to be only two possibilities—the diverting of part of the stream all the time, or the diverting of the whole stream at periods. In order to examine to which method the preference should be given for the greatest accuracy the cross section of the stream may be considered not as gradually differentiating in temperature and composition from the center outward, but as divided into zones of different temperatures and compositions as shown in zones 1 to 5, in figure 11. Each zone, except the center one, is, of course, the cross section of a hollow cylinder. It needs no mathematical argument to demonstrate that samples represented by continuous cuts, as *A* and *B*, would not be representative, none of the zones or the hollow cylinders being rep-

<sup>a</sup> Wraith, William, Sampling anode copper, etc.: Trans. Am. Inst. Min. Eng., vol. 41, 1910, p. 318.



resented in its proper ratio by such cuts. A cut such as at *C* would satisfy this requisite.

However, such a cut appears impracticable, and we are obliged to look to the second method, that of cutting the whole stream at periods. Such a cut is shown at *D*, in which clearly there are represented, in their proper ratio, all the geometrical elements of the stream's cross section. Such a cut has the further advantage that its correctness is independent of the form of the cross section of the stream. It may be remarked that in practice a cut procured with a paddle will not be at right angles with the direction of the stream;

that while the paddle moves through the stream from *a* to *b*, the stream moves from *a* to *c*, and there is an oblique cut, *D<sub>1</sub>*, which still contains all the elements of the cylinder in their proper ratio. Probably still closer to the real conditions is the following assumption: One who has seen a snowslide on a broad mountainside knows that it starts at a point, develops at a considerable angle, and ends with a broad base. So a paddle in its passage through a liquid stream will, undoubtedly, form a widening path, as represented in the figure by cut *D<sub>2</sub>*, which still contains the

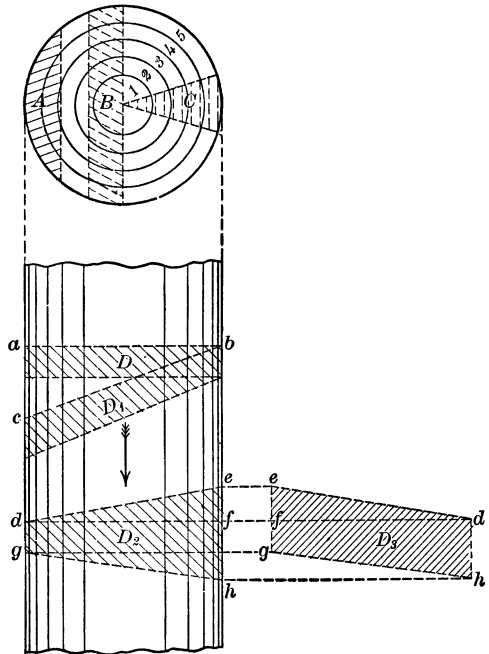

FIGURE 11.—Sections of stream of molten charge of bullion.

correct ratio of all the elements of the stream, as demonstrated in *D<sub>2</sub>* of the figure, which is derived by revolving around its center that part of the cut *D<sub>2</sub>* designated by *d f e*, 180°.

**DETAILS OF SAMPLING METHOD COMMONLY USED.**

At the Washoe plant of the Anaconda company and many other smelteries sampling of great quantities of copper bullion is now conducted according to the plan just outlined. The mode of operation at the Washoe plant is described by Wraith,<sup>a</sup> as follows:

At the smelter the sampling is done by "shotting" into water a small portion of the molten stream of copper as it flows from the furnace, by "batting"

<sup>a</sup> Wraith, William, Loc. cit.

the stream with a wooden paddle. The first sample is taken 30 minutes after pouring is started, three other samples being taken at 1-hour intervals, each sample weighing from 4 to 6 ounces. The samples are dried, examined for particles of burnt wood, screened on a 10-mesh screen of No. 8 wire to remove the fines, the oversize then screened on a 4-mesh screen of No. 20 wire to remove the coarse, the undersize of this screen being taken as the sample. The four portions thus obtained are thoroughly mixed and split in half by passing over a 16-slot splitting device, slots being 0.5 inch wide. One-half of the sample is sent to the laboratory for analysis and one-half kept as a duplicate.

An essential of good management in every enterprise is to guard against difficult contingencies. It is therefore wise to consider a molten furnace charge heterogeneous and to take samples accordingly. Thus, it is best to take the shot samples at equal time intervals while the stream is running, or, better still, each time that a casting is made or after a given number of pieces have been cast, and then to make up the general sample of equal weights of the individual shot samples. Only in this way will the general sample represent a correct average.

#### LADLE-SAMPLING TESTS OF DORE BULLION.

In Table 4 are incorporated the results of ladle-sampling tests of doré bullion at the Raritan works, by C. H. Aldrich. They demonstrate that with this bullion, too, ladle sampling can be carried out safely only when no skulling is possible. Although the silver content was irregular, the gold undeniably showed a marked tendency to concentrate in the skull; that is, in the parts of the bullion that froze first. Table 4 follows:

TABLE 4.—Results of analyses of hot-ladle and of skulled-ladle samples of doré bullion.

#### EASTERN DORÉ.

| Lot No.                      | Hot-ladle samples.     |       | Skulled-ladle samples. |       | Difference. |        |       |        |
|------------------------------|------------------------|-------|------------------------|-------|-------------|--------|-------|--------|
|                              | Assay parts per 1,000. |       | Assay parts per 1,000. |       | Silver.     |        | Gold. |        |
|                              | Silver.                | Gold. | Silver.                | Gold. | Over.       | Under. | Over. | Under. |
| 1.....                       | 973.79                 | 11.21 | 977.62                 | 10.78 | 3.83        | .....  | ..... | 0.43   |
| 2.....                       | 981.56                 | 10.84 | 977.32                 | 10.78 | .....       | 4.24   | ..... | .06    |
| 3.....                       | 977.19                 | 9.71  | 976.32                 | 8.98  | .....       | .87    | ..... | .73    |
| 4.....                       | 981.12                 | 8.18  | 973.46                 | 7.84  | .....       | 7.66   | ..... | .34    |
| 5.....                       | 976.89                 | 8.21  | 980.13                 | 8.17  | .....       | 3.24   | ..... | .04    |
| 6.....                       | 966.60                 | 10.40 | 976.88                 | 10.42 | .....       | 10.28  | ..... | 0.02   |
| 7.....                       | 977.72                 | 9.58  | 976.93                 | 9.27  | .....       | .79    | ..... | .31    |
| 8.....                       | 976.92                 | 11.18 | 976.80                 | 10.60 | .....       | .12    | ..... | .58    |
| 9.....                       | 979.13                 | 10.37 | 979.30                 | 10.30 | .....       | .17    | ..... | .07    |
| 10.....                      | 976.00                 | 10.40 | 976.91                 | 9.89  | .....       | .91    | ..... | .51    |
| Total.....                   | .....                  | ..... | .....                  | ..... | 18.42       | 13.68  | .02   | 3.07   |
| Mean difference per lot..... | .....                  | ..... | .....                  | ..... | .47         | .....  | ..... | .31    |

TABLE 4.—Results of analyses of hot-ladle and of skulled-ladle samples of doré bullion—Continued.

## WESTERN DORÉ.

| Lot No.                      | Hot-ladle samples.     |       | Skulled-ladle samples. |       | Difference. |        |       |        |
|------------------------------|------------------------|-------|------------------------|-------|-------------|--------|-------|--------|
|                              | Assay parts per 1,000. |       | Assay parts per 1,000. |       | Silver.     |        | Gold. |        |
|                              | Silver.                | Gold. | Silver.                | Gold. | Over.       | Under. | Over. | Under. |
| 11.....                      | 992.85                 | 5.45  | 991.11                 | 4.99  | .....       | 1.74   | ..... | 0.46   |
| 12.....                      | 989.48                 | 5.47  | 992.78                 | 5.42  | 3.30        | .....  | ..... | .05    |
| 13.....                      | 991.55                 | 6.05  | 990.84                 | 5.86  | .....       | .71    | ..... | .19    |
| Total.....                   | .....                  | ..... | .....                  | ..... | 3.30        | 2.45   | ..... | .70    |
| Mean difference per lot..... | .....                  | ..... | .....                  | ..... | .28         | .....  | ..... | .23    |

## RAHT'S DESCRIPTION OF SAMPLING LEAD BULLION.

In the lead smelteries preference seems to be given generally to the sampling of molten charges as against the sampling of the cast products. In 1894 Raht<sup>a</sup> gave a comprehensive account of the American practice in that branch of industry. After a detailed description of the methods of sampling the solid materials as they had been practiced up to about that time, Raht comes to the following conclusion: "From all this it appears that all methods of sampling which treat bullion in the solid form must necessarily be more or less unreliable. This leads to the conclusion that the sampling should be done while the bullion is in the molten state." As to the latter method, Raht comments as follows:

The taking of dip samples out of the molten metal was proposed by one of the eastern refiners several years ago, and it came quite recently into use at one of the smelting works in Colorado with very satisfactory results, the method adopted being as follows: After melting the bullion bars down in a kettle holding about 20 tons, the coppery dross is skimmed off and sent back to the blast furnace to be smelted over; with this one of the worst sources of error in sampling is removed. The bullion is then thoroughly stirred, say, for five minutes, and while this is still going on a number of samples are taken by means of a small ladle holding approximately one-half an assay ton of metal. It is important that this ladle should be at least as hot as the bullion, so that none of the metal would stick to its surface, otherwise the samples would be too low in silver. The samples thus obtained are taken direct for assaying without any trimming or clipping. Instead of trimming the sample down to the exact weight of half an assay ton, the exact weight of each sample is ascertained, whatever it may be, and from the resulting silver button the contents are figured. Care is taken, however, in the selection of the samples for assaying out of the great number originally taken that these should be somewhere near

<sup>a</sup> Raht, A., The distribution of silver in lead bullion, and the different methods of sampling: Min. Ind., vol. 3, 1894, p. 414.

the same weight, so that when they are cupeled side by side they would finish about the same time.

It will be seen that all the objections to punch sampling named above are met in this method. Still, another one might be raised against it, which is the uncertainty whether the mixture was thorough. I must say that this does not appear to carry much weight, but it can be overcome by taking samples at regular intervals out of the stream of metal running from the kettle into the molds. These samples would have to be remelted in a graphite crucible and out of this again one-half assay ton samples taken, which are then treated as above. This method, of course, brings in again the objection to the remelting. There can not be the least doubt that either of these two dip samples would be nearly absolutely correct, but they can be carried on only at the works of the seller of the bullion, as it would be next to impossible to obtain a correct sample from the dross skimmings. It is to be hoped that the dip sample will be generally introduced wherever practicable, and so do away with the annoying sample and assay differences between the bullion producer and refiner.

This statement pertained to the practice of about 20 years ago. H. H. Alexander, manager of the American plant at Perth Amboy, N. J., informs the author that practically identical methods are preferred to-day.

#### SAMPLING MOLTEN PIG IRON.

In the sampling of pig iron one of the optional methods of the United States Steel Corporation is described as follows by the chemists' committee of that corporation:<sup>a</sup>

*Plate or pat test.*—With a suitable hand ladle a portion is dipped from the stream of molten iron and, with the spoon of the ladle resting upon a clean, dry, iron plate, a pat of such size as may be desired is poured thereon.

The use of the water-shot sample is to be considered as in violation of the standard method.

*Number of samples to be taken.*—As tending to a reasonable degree of accuracy, it is recommended that a portion be secured, timed as nearly as may be practicable for the middle of each ladle of iron representing the cast. Equal portions from each of these samples are conveniently combined for subsequent analysis.

*Preparation of the sample.*—The tests are either drilled or crushed, as required. If crushed, only that portion passing an 80-mesh sieve is used for the subsequent analysis.

For any material more valuable than steel a strong objection would be raised against the use as sample of only that part of the crushed and ground material that passed a certain mesh sieve, because coarse and fine parts so separated would always show an appreciable difference in composition. Such separation would involve uncertainty and would invite carelessness in the preparation of the sample.

---

<sup>a</sup> The methods of the United States Steel Corporation for commercial sampling and analysis of pig iron: Jour. Ind. and Eng. Chem., vol. 4, 1912, p. 801.

## SAMPLING MISCELLANEOUS METALLIC SCRAPS, ETC.

There are a number of plants where miscellaneous metallic scraps, borings, sweepings, etc., are bought for melting and refining, the lots being of greatly varied composition. Unless these materials are sufficiently fine to allow sampling in the solid state, according to the recognized principles of sampling ores, it is desirable to melt them and to take a sample by one of the approved methods of sampling molten material.

**SAMPLING SOLID MATERIALS.****EXTRANEOUS MATTER IN BULLION.**

The sampling of solid materials is at present of greater importance than the sampling of molten ones, because it has become an accepted practice—or it may be even a legal right—for the receiver of metallic materials to sample the actual shipments received, under the supervision of a representative of the shipper. This practice is no doubt fair, because a shotted sample may correctly represent a furnace charge but does not necessarily represent correctly the solid castings derived from the charge. A shotted sample will in all probability be clean metal or bullion, whereas to the castings there may have been added unavoidably oxides of the metals, slags, and mold wash, the presence of which has no value whatsoever. Therefore the purchaser is entitled to have this barren material properly represented in his sample. The shipper's interests against loss, by having an undue proportion of these same materials enter the sample, are best guarded by his taking care to ship the cleanest possible castings, bars, slabs, pigs, or ingots.

As the foreign materials mentioned are, as a rule, confined to the surface of the castings, the most simple and efficacious method of removing them is the so-called pickling, which consists in dumping the pieces while still red hot into water, from which, after sufficient chilling, they emerge with a clean metallic surface.

Practically all copper bullion destined for sampling is treated in that way, and there is little likelihood that more than the proper proportion of the remnant of foreign materials enters the sample. As the foreign materials are readily ground to powder in the course of the preparation of the sample, and are, therefore, easily separated from the bulk of the clean, coarse metallic materials, there is no difficulty in determining how much the contents of the latter are reduced in the average sample.

## TABULATED DATA ON EFFECT OF EXTRANEEOUS MATTER.

Table 5, following, gives such data on large consignments of copper bullion.

TABLE 5.—Results of determinations showing reduction of average copper content in different types of copper bullion by foreign materials.

| Type No. | Class of copper bullion.                   | Size of constituents. | Ratio of fine to coarse. | Copper.          | Reduction; coarse minus average. |
|----------|--|-----------------------|--------------------------|------------------|----------------------------------|
|          |  |                       |                          | <i>Per cent.</i> | <i>Per cent.</i>                 |
| 1        | Converter refined anodes, pickled.....     | Fine.....             | 1                        | 98.642           | } 0.031                          |
|          |  | Coarse.....           | 20.07                    | 99.307           |                                  |
|          |  | Average.....          |                          | 99.276           |                                  |
| 2        | Converter gas-finished slabs, pickled..... | Fine.....             | 1                        | 98.130           | } .079                           |
|          |  | Coarse.....           | 14.26                    | 99.342           |                                  |
|          |  | Average.....          |                          | 99.263           |                                  |
| 3        | Converter gas-finished pigs.....           | Fine.....             | 1                        | 93.139           | } .233                           |
|          |  | Coarse.....           | 23.52                    | 98.860           |                                  |
|          |  | Average.....          |                          | 98.627           |                                  |
| 4        | Converter gas-finished pigs.....           | Fine.....             | 1                        | 95.756           | } .330                           |
|          |  | Coarse.....           | 8.50                     | 98.896           |                                  |
|          |  | Average.....          |                          | 98.566           |                                  |
| 5        | Converter gas-finished slabs.....          | Fine.....             | 1                        | 96.046           | } .250                           |
|          |  | Coarse.....           | 10.25                    | 98.858           |                                  |
|          |  | Average.....          |                          | 98.608           |                                  |
| 6        | Converter gas-finished slabs, pickled..... | Fine.....             | 1                        | 98.350           | } .094                           |
|          |  | Coarse.....           | 3.149                    | 98.742           |                                  |
|          |  | Average.....          |                          | 98.648           |                                  |
| 7        | Reverberatory blister slabs.....           | Fine.....             | 1                        | 96.432           | } .215                           |
|          |  | Coarse.....           | 11.50                    | 99.120           |                                  |
|          |  | Average.....          |                          | 98.905           |                                  |
| 8        | Blast-furnace black pigs.....              | Fine.....             | 1                        | 95.107           | } .211                           |
|          |  | Coarse.....           | 9.89                     | 97.407           |                                  |
|          |  | Average.....          |                          | 97.196           |                                  |

The last column in this table would represent the overcharge in copper had the assay been made on a clean shotted sample. In the table the figures for copper are used as the basis of comparison; other elements, as the precious metals, would be affected in the same proportion. The constituents designated "coarse" (clean metallic materials) and those designated "fine" were separated by means of a screen having 40 meshes of No. 30 wire to the linear inch. It should be remarked that as some of the "fine" carried more chemical impurities than the "coarse" constituents, the reduction in the average copper content was not entirely due to mechanically carried foreign materials. The table is self-explanatory, but it may be noted that much of the converter copper of type 4 contained slag, and this bullion showed the greatest loss in its average copper content below that of the coarse part or the clean metallic materials. The refined copper (type 1) showed plainly its greater freedom from mechanical admixtures as compared to the crude-copper bullions.

## EFFECT OF MOLD WASH ON DRILL SAMPLES.

It was at one time feared by the Anaconda company that mold wash might have an undue effect on the assay results of drill samples

from certain copper anodes, and a direct test was made as described below. The regular shotted sample was taken from the homogeneous furnace charge and one-half of the latter was cast into clean molds, the other half being cast into molds with a heavy clay wash, and the anodes were drilled for samples. The assay results are shown in Table 6, which clearly shows that whatever effect the wash may have on the assay results of one sample its magnitude falls within the differences inherent to duplicate sampling and assaying.

TABLE 6.—*Results of test of effect of mold wash on metal contents of drill samples.*

| Kind of sample.      | Copper.          | Silver per ton. | Gold per ton.  |
|----------------------|------------------|-----------------|----------------|
|                      | <i>Per cent.</i> | <i>Ounces.</i>  | <i>Ounces.</i> |
| Shotted.....         | 99.34            | 79.90           | 0.486          |
| Anodes without wash: |                  |                 |                |
| Coarse (8.392).....  | 99.328           | 79.58           | .....          |
| Fine (1).....        | 98.846           | 80.35           | .....          |
| Average.....         | 99.277           | 79.66           | .472           |
| Anodes with wash:    |                  |                 |                |
| Coarse (7.925).....  | 99.291           | 79.77           | .....          |
| Fine (1).....        | 98.937           | 80.61           | .....          |
| Average.....         | 99.251           | 79.86           | .472           |

**EFFECT OF MOISTURE IN BULLION.**

Although the pickling process eliminates to a minimum the presence of undesirable foreign materials, a new difficulty in the form of water is introduced, particularly when the process is applied to gas-finished converter copper and to blister copper. It should be remembered that when copper bullion is produced from sulphide the molten metallic bullion absorbs large volumes of sulphur dioxide gas, which it emits in the process of cooling and freezing. As a result the solid bars contain holes or blisters of various sizes, and also capillary ducts from the center to the surface. All of the holes and ducts are at first filled with the sulphur dioxide gas, which, when the bars or slabs are plunged into water, contracts to a considerable degree, and is then completely absorbed by the water, which, under full atmospheric pressure, fills the cavities. The water is then under capillary pressure and is evaporated with far more difficulty than the surface moisture.

The presence of water in converter-copper slabs, after transoceanic shipment, was discovered in an interesting manner at the Baltimore Copper Works, whose general manager, W. H. Peirce, under whom the investigation was conducted, has kindly furnished all the data for the author's use.

In a most carefully conducted test, samples of about 2,000 tons of pig copper obtained by drilling were compared with samples of the same copper after it had been melted to a homogeneous furnace charge. The results of the comparison showed a seeming loss in copper, which, as judged by past experience in other melting tests, presented itself at once as incredible. Repeated tests, however, with the same brand of copper confirmed the first result. On closer investigation of the handling and storage of this material after arrival in the yards of the company it was learned that many of the drillings from the sample pigs showed moisture sensible to the touch, which could not have had its origin in surface moisture. Many careful moisture determinations were made directly on the pigs, most of which were found to contain 0.35 to 0.55 per cent of water. In the process of drying it was noticed that the moisture did not begin to dissipate rapidly until a temperature of 82° C. (180° F.) had been reached and that it was not effectively driven off until the metal attained a temperature of 135° to 150° C. (275° to 300° F.). An exposure to such temperature for three hours seemed sufficient. At these high temperatures the steam was emitted from the little craters with an audible hissing sound. A temperature of 205° to 235° C. (400° to 450° F.) caused a slight oxidation of the copper.

The drying of the pigs was conducted in heating pans and in ovens. Determinations of the moisture in drillings always yielded lower results than those for moisture in the pigs, but the conclusion was reached that the drying of the drillings was not permissible on account of evaporation during the process of drilling. This may be understood when we note that with the temperature of the surrounding air at 14.8° C. (58.6° F.) the drillings made with the drill operated on the high-speed pulley had a temperature of 23.8° C. (74.8° F.), and drillings made with the drill running at low speed had a temperature of 19.2° C. (66.6° F.). These temperatures are probably much too low, because the drillings will rapidly transfer their heat to the large mass of surrounding copper, making it impossible to measure their initial temperatures.

In the shipment of copper pigs from Great Falls, Mont., to the Atlantic seaboard a considerable loss of weight always resulted, which could not be accounted for by any possible loss of solid materials. Tests undertaken at the point of shipment with copper pigs still hot from the bosh (water-cooling tank) yielded results analogous to those obtained in Baltimore.

It is needless to say, that it is to the interest of every purchaser to have the amount of water determined in all materials that are apt to retain it, and to make settlements on dry weights. Moreover, the water content should also be determined at works where the material



passes from one department to another, otherwise one department will be credited with an excess of precious materials, the weight of which is water, and another will be charged with the loss of a valuable constituent which in reality does not exist.

### RELATION OF SHAPE TO DIFFUSION IN CASTINGS.

We have seen that the degree of diffusion in a molten alloy and the consequent heterogeneity in a casting are dependent on several conditions. As a homogeneous material offers no difficulty and risk of error in sampling, it may now be asked as to which shape of casting of an alloy or bullion will show the maximum degree of concentration or heterogeneity due to diffusion and in which shape diffusion will not occur.

It will be readily understood that, if any given quantity of a molten binary alloy, provided it be hypoeutectic, be cast into the form of a sphere or globe, the diffusion of one of its constituents, on uniform cooling along its whole surface, will take place from the surface toward one point, the center. In any other shape the diffusion must take place toward a line, as in a cylinder; or toward a plane, as in a thin plate. In a sphere there is consequently the shape in which the maximum degree of concentration must take place; it would be the most irrational shape of a casting made for the purpose of sampling. If the same quantity of the alloy mentioned be cast into an infinitesimally thin film, with infinite other dimensions, the diffusion must obviously be infinitesimal.

The foregoing discussion indicates that a rational casting that will yield the most representative sample should be thin with large horizontal dimensions.

### BEARING OF SHAPE OF CASTING ON METHOD OF SAMPLING.

The method of taking a sample must largely be determined by the shape of the casting. In metallurgical practice the spherical shape will probably not be met, although by sawing a sector of the sphere a correct sample would be obtained. By drilling, a correct sample would not be obtained unless it were possible to drill a conical hole, with the apex of the cone in the center of the sphere.

The hemisphere or button shape, derived from casting bullion in slag pots, has now and then been seen. Such castings may be treated for sampling in the manner in which round cakes would be treated.

There remain to be considered the ingot, bar, or pig, whose cross sections range from the square to any kind of a trapezoid; and the plate, cake, or slab, whose cross sections are elongated rectangles or trapezoids.

SAMPLING OF BARS.

In order to determine the best mode of taking a sample it should first be known what the character of the diffusion in a casting of a given shape is. For the sake of simplicity of theory, the first consideration may be a bar of square cross section, whose length is of such dimensions that the diffusion from the ends in the longitudinal direction is practically zero. It may be emphasized that it is immaterial what elements are subject to diffusion—gold in silver bullion, silver in copper bullion, or carbon and phosphorus in steel.

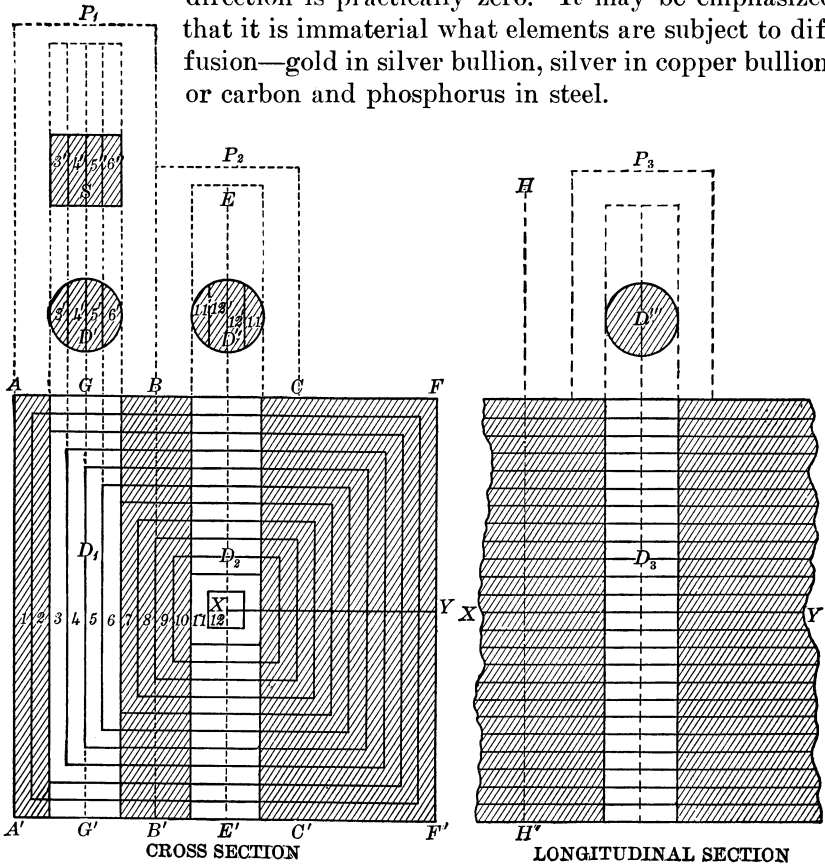

FIGURE 12.—Sections of hypothetical bullion bar. At left, cross section; at right, longitudinal section.

In a bar with the square cross section and the ends eliminated, there need be considered diffusion as taking place only at right angles from the four sides. Let the view at the left of figure 12 represent such a cross section. For the purpose of the analysis it is perfectly permissible to assume that the originally homogeneous molten alloy solidifies at an equal rate from all four sides of the bar and that diffusion and differentiation in composition take place equally from all four sides. The difference in composition of the bar will change

from each point of the four sides along a line at right angles until they reach the meeting points. There is then, as the simplest geometrical proposition, the bar composed of concentric layers, each layer extending around the four sides and of uniform composition, but each succeeding layer differing from the preceding one. In figure 12 these layers, shown in cross section, are numbered 1 to 12.

#### SAMPLING BY DRILLING.

As the methods of drilling the bars for samples is the favorite and probably the cheapest one, it is well to analyze its accuracy when applied to the several shapes of castings. In figure 12 let  $D_1$  represent a drill-hole cylinder, with  $D'$  its cross section, and representing as sample the parallelepiped  $P_1$  whose vertical section is the area designated by  $AA'B'B$ . Now, if there were diffusion with gradual differentiation of composition in one horizontal direction only, the drill-hole cylinder and its corresponding parallelepiped, with their contents, would conform to the original algebraic requisite of correct

sampling,  $\frac{W}{w} = \frac{N}{n}$ . To demonstrate this, let it be imagined that the vertical layers of the cross section of the bar extend the full length of the parallelepiped, and let it be supposed that the content of primary metal increases in arithmetical progression from the outer layer to the center, in the way that layer 1 has the value 1 and layer 12 the value 12. In the parallelepiped  $P_1$  the eight layers would have the average value of 4.5, and in the drill-hole cylinder the layers 3, 4, 5, and 6 would possess the same average value, the relationship that the fundamental formula expresses.

Instead of this regularity in diffusion and hypothetical geometrical conditions there is in the cross section of the bar diffusion in four directions, creating geometrical elements which, regarding composition, no longer have equal relations in the drill-hole cylinder and in the parallelepiped. For example, it may be noted that drill-hole cylinder  $D_1$  passes a part of the horizontal layers and then includes four vertical layers in their full length, each of them, of course, being of different composition. In the parallelepiped  $P_1$  these layers are represented by rectangular prisms of equal cross sections, but of unequal altitude; therefore the weight or volume of these prisms is proportional to that dimension. It follows that to obtain their proper proportion in the sample, or to have the weight ratios of each prism in the parallelepiped and in the sample equal, it is necessary to cut them in their full cross section, which could be accomplished with a square or rectangular hole, as shown by the cross section  $S$  in the figure. The round drill hole through the vertical layers can not give a theoretically correct sample, as the weight ratios of the layers

in the bar and the parts in the sample differ, as do the areas of the segments 3', 4', 5', and 6' in the cross section D', instead of being equal. Moreover, no drill hole properly represents the horizontal layers in the square cross section of such a bar. To illustrate this statement, P<sub>1</sub> and D<sub>1</sub> may be ignored for the moment and drill hole D<sub>2</sub> considered as the sample of the whole bar. As the drill hole proceeds from layer 1 to 10 it takes an increasing part of each succeeding layer until, with layers 11 and 12, the whole layer is included in the sample. If the weights of the layers are designated as W<sub>1</sub>, W<sub>2</sub>, W<sub>3</sub>-----W<sub>12</sub>, and the weights of their parts in the sample w<sub>1</sub>, w<sub>2</sub>, w<sub>3</sub>-----w<sub>12</sub>, the result should be, if the sample is to be correct—

$$\frac{W_1}{w_1} = \frac{W_2}{w_2} = \frac{W_3}{w_3} = \dots = \frac{W_{12}}{w_{12}}$$

However, instead of these equal ratios, the ratios are as follows:

*Weight ratios of layers included in drill-hole sample D<sub>2</sub> in figure 12.*

| Layer No.  | 1              | 2              | 3              | 4              | 5              | 6              | 7              | 8             | 9             | 10            | 11 | 12 |
|------------|----------------|----------------|----------------|----------------|----------------|----------------|----------------|---------------|---------------|---------------|----|----|
| Ratio..... | $\frac{2}{23}$ | $\frac{2}{21}$ | $\frac{2}{19}$ | $\frac{2}{17}$ | $\frac{2}{15}$ | $\frac{2}{13}$ | $\frac{2}{11}$ | $\frac{2}{9}$ | $\frac{2}{7}$ | $\frac{2}{5}$ | 1  | 1  |

The foregoing discussion indicates that if a bar with a square cross section is pierced by one drill hole for a sample the sample can not have the same content as the bar, or, algebraically expressed,  $\frac{W}{w} > \frac{N}{n}$ .

A similar but lesser differentiation pertains to a sample representing several drill holes.

SAMPLING BY SAWING OR PLANING.

In order to obtain the proper relations between the contents of a bar of square cross section and the contents of the sample, it should now be plain that the sample must be obtained from the full or the half cross section of the bar. If the whole bar be considered as a parallelopiped with great altitude and its interior composed of geometric elements of differing composition, as demonstrated in the cross section of figure 12, a saw cut to the center of the bar would then be a parallelopiped of low altitude, but with all the identical elements of the bar in its cross section. There would consequently be equal weight ratios in the bar and in the sample for all the 12 elements in the figure, or, algebraically expressed,

$$\frac{W_1}{w_1} = \frac{W_2}{w_2} = \frac{W_3}{w_3} = \dots = \frac{W_{12}}{w_{12}} = \frac{N_1}{n_1} = \frac{N_2}{n_2} = \frac{N_3}{n_3} = \dots = \frac{N_{12}}{n_{12}}$$

or for the whole bar and sample,  $\frac{W}{w} = \frac{N}{n}$ ; that is, there would be all the requisites of a theoretically correct sample.

In sampling a bar like that just described it would be necessary to have a cut of one-half of a bar only, and the cut could be either horizontal or vertical, because a half taken in either way would have the same composition as the remaining half. In actual castings, however, the distribution of contents is not regular, but for all practical purposes it is symmetrical, as illustrated in figure 13, the hypothetical layers being of greater thickness below the freezing center than above it. This differentiation is due to the fact that the freezing of the molten alloy takes place more rapidly from the bottom

than from the top, because the metallic mold at the bottom more rapidly absorbs the heat than does the air at the top; consequently the freezing center  $X$  is shifted above the geometric center  $Y$ . By the line  $AB$  the cross section is divided into two symmetrical halves, whereas the halves divided by the line  $CD$  are asymmetrical regarding the internal constitution of the bar. Therefore if a representative sample is to be taken by half cuts the sawing must be from either side of the bar to the

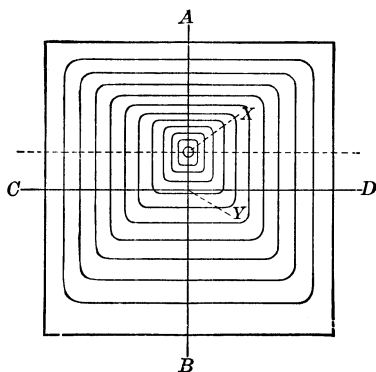

FIGURE 13.—Cross section of bar of bullion, showing freezing and geometric centers.

line  $AB$ , or if a vertical cut be preferable, alternate cuts from the top or the bottom of the bar should be made, each to the line  $CD$ , such cuts being practically the same as full cuts through the bar.

#### SAMPLING CASTINGS HAVING A BEVEL.

In metallurgical practice, most castings do not have vertical sides but, so that they may be more readily removed from the molds, the sides incline from the top to the bottom surface, forming an acute angle with the top and an obtuse angle with the bottom. Thus, each side of the plate may be said to have a prism. This is called the bevel, and is sometimes known as the overhang. It gives to the cross section of bars and plates the trapezoidal shape. The foregoing discussion relative to square bars applies as well to bars having a section of trapezoidal shape.

#### RELATION OF BEVEL TO SAMPLING.

It has lately been pointed out by Liddell<sup>a</sup> that owing to the relation of the bevel to a templet section certain difficulties may arise

<sup>a</sup> Liddell, D. M., Sampling errors due to copper-bar shapes: Eng. and Min. Jour., vol. 92, 1911, p. 1173.



the parallelepipeds and the respective drill-hole cylinders in the whole slab have the same volume and weight ratios. In figure 15, B, the bevel covers one-fourth of the templet section. The parallelepiped is reduced to 87.5 per cent of its full volume and weight and differs to that extent from those lying beyond the bevel zone in the inner parts of the slab. The drill-hole cylinder is still 100 per cent, and it is evident that we have an excess of sample of 12.5 per cent. In such a simple case as this, the difficulty of the excessive sample from the bevel zone may be overcome by omitting the drilling of every eighth hole in that zone. In figure 15, C, the bevel covers one-half of the templet section; the parallelepiped is reduced to 75 per cent of its full volume, and the drill-hole cylinder to 89.4 per cent. The sample, therefore, is in excess 16.1 per cent of its proper weight. This excess may be reduced approximately by the omission, in drilling, of every sixth hole in the bevel zone. In figure 15, D, the bevel is shown covering three-fourths of the templet section; the parallelepiped is reduced to 62.5 per cent of its full volume, and the drill-hole cylinder to 66.7 per cent; the excess of the sample is approximately 6.3 per cent of its proper weight. The omission, in drilling, of every sixteenth hole of the bevel zone would nearly eliminate this weight error. In figure 15, E, the bevel is equal to the templet section. The parallelepiped and drill-hole cylinder are both reduced to 50 per cent. There is here the case of figure 12 with geometrically correct conditions for sampling, just as in figure 15, A.

To take a drill sample from the edge or bevel zone of a bar or slab under conditions geometrically correct, it will now be seen that there are only two possibilities—the bevel must be zero, or its line must cut diagonally the edge-zone parallelepiped that underlies the templet section. All other degrees of beveling yield an excess of sample, the maximum of which appears to be 16.1 per cent. In no case can there be found a deficiency of sample.

#### ALGEBRAIC EXPRESSION OF EFFECT OF BEVEL.

The foregoing conditions may be put into algebraic expressions, as follows: Let  $\frac{W}{w}$  be the weight ratio between the edge or bevel-zone parallelepipeds (or their truncated remnants) and the drill-hole cylinders, and  $\frac{W_n}{w_n}$  the same ratio for the inner parts of the bar or slab. Then in figure 15, A and E,  $\frac{W}{w} = \frac{W_n}{w_n}$ ; and in figure 15, B, C, and D,  $\frac{W}{w} > \frac{W_n}{w_n}$ .

Should the shape and size of a bar be such that several drill holes must be put through the bevel, the geometry of the simple exam-

TEMPLET SECTION

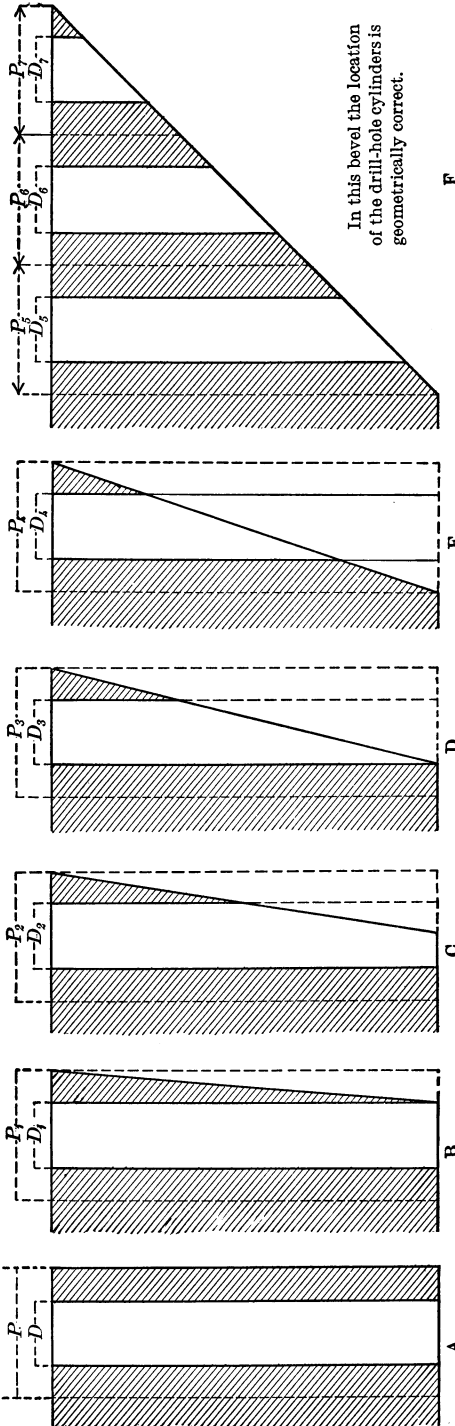
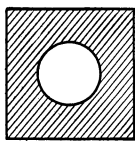

In this bevel the location of the drill-hole cylinders is geometrically correct.

|                                       |               |
|---------------------------------------|---------------|
| Percentage of parallel piped.....     | $P_4 = 100.0$ |
| Percentage of drill-hole cylinder.... | $D = 100.0$   |
| Excess of sample, per cent.....       | 0.0           |

|               |              |              |              |
|---------------|--------------|--------------|--------------|
| $P_1 = 87.5$  | $P_2 = 75.0$ | $P_3 = 62.5$ | $P_4 = 50.0$ |
| $D_1 = 100.0$ | $D_2 = 89.4$ | $D_3 = 66.7$ | $D_4 = 50.0$ |

12.5

16.1

6.3

0.0

FIGURE 15.—Views showing relation of drill-hole cylinder, or sample, to various bevels.



ples given above will apply equally to such parts of the several parallelipeds and drill-hole cylinders as are cut by the bevel line. Figure 15, F, illustrates the simplest case of such a kind. In the view shown these are clearly correct geometric conditions for each paralleliped and drill-hole cylinder.

As it has been assumed that the volumes are a relative measure of the weights, it is permissible, with one exception, to take the sectional areas shown in figure 15, A, B, C, D, and E, as measures for the respective volumes. This rule is correct for all cases in which the bevel plane cuts through the full width of the drill-hole cylinder, or in which the latter is not cut at all. The exception to this rule is presented in figure 15, C, in which the drill-hole cylinder is cut by a plane from some point in its side to the diameter of its base. In this case it is necessary to find the volume of the intact part of the drill-hole cylinder by first calculating the volume of the ungula or "cut-off" and deducting this from the full volume of the cylinder. In this special case, where the straight edge of the ungula is equal to the diameter of the cylinder base, the volume of the ungula (fig. 16) is found according to the following formula, in which  $h$  represents the height of the ungula and  $r$  the radius of the cylinder.

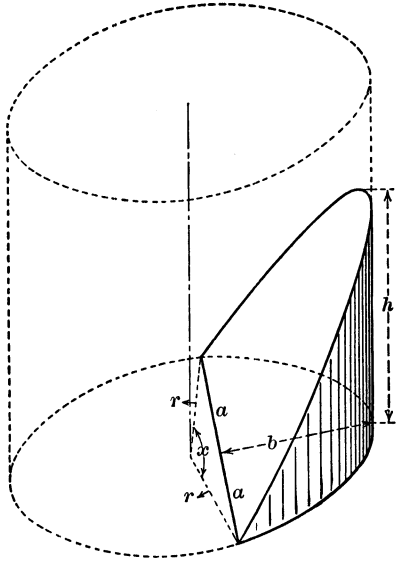

FIGURE 16.—The ungula.

$$\text{Volume} = \frac{2}{3} r^2 h$$

For any case in which the cylinder base is intersected elsewhere than through its diameter the formula for the volume of the ungula becomes

$$\text{Volume} = \frac{h}{3b} \left[ a(3r^2 - a^2) + 3r^2(b - r) \right] \frac{\pi}{180}$$

The functions represented by the factors in this formula are shown in figure 16.<sup>a</sup>

BEARING OF INNER STRUCTURE OF BAR.

The inner structure of a bar or slab is an invisible factor and its variations in practical sampling may offset, in certain cases, geo-

<sup>a</sup> By courtesy of Mr. Werner Fetz.

metric errors. It is, therefore, as important to take this factor into account by making a sufficient number of drill holes as it is to conform to the proper geometric shape.

Liddell<sup>a</sup> pointed out that a drill hole through the center of the templet section in the corner of a beveled bar could not give a theoretically correct sample, and cited mathematics to support his contention. Smoot<sup>b</sup> has suggested that the difficulty could be overcome by shifting the drill hole from its regularly assigned position in such direction as would compensate for the inherent error. In actual practice the proper placing of the drill hole to provide such compensation would no doubt be seldom attained, nor would it overcome other than geometric difficulties. The sampling of the edge zone or bevel by drilling can, at the best, be made only approximately accurate.

#### SAMPLING OF PLATES OR SLABS.

The heterogeneous plate may be considered essentially a succession of horizontal layers formed by the freezing of the molten alloy from the top downward and from the bottom upward. These layers are represented in figure 12. Of course every plate has its four sides or edges which, as geometrical elements, each may be considered as representing one-half of a bar; for example, in the cross section of figure 12 the area extending from the side  $AA'$  to the line  $EE'$  may be considered as part of the plate cross section incompletely shown in the longitudinal section, and as thus giving a vertical section through the edge and other parts of the plate. The edge contains all the elements of diffusion that are contained in the whole plate, and, as in the bar, they may be obtained in a theoretically correct sample by a continuous cut only. Thus may be eliminated the edge, or the edge zone, from consideration in the sampling of the interior part of the plate, which naturally must also contain all the elements of diffusion. It may now be assumed that each layer is uniform throughout, all of equal horizontal extension, but each of different composition. It clearly follows that for a correct sample it is necessary that there be obtained from each of these layers such a part that all these parts are of equal horizontal area; the shape of this area being immaterial, as is also the location from which the sample is taken. Nor need it be assumed that the layers be of equal thickness in order to obtain from all their proper proportion, for they all may be cylinders, prisms, etc., of equal cross-sectional area and unequal altitude; therefore, their weight is proportional to the latter dimension. Consequently, in the longitudinal section of

<sup>a</sup> Liddell, D. M., Sampling errors due to copper-bar shapes: Eng. and Min. Jour., vol. 92, 1911, p. 1173.

<sup>b</sup> Smoot, A. M., The mathematics of copper sampling: Eng. and Min. Jour., vol. 93, 1912, p. 1213.

figure 12, with the accustomed designations as applied to the total layers and their corresponding parts in the sample,

$$\frac{W_1}{w_1} = \frac{W_2}{w_2} = \frac{W_3}{w_3} = \dots = \frac{W_{24}}{w_{24}} = \frac{N_1}{n_1} = \frac{N_2}{n_2} = \frac{N_3}{n_3} = \dots = \frac{N_{24}}{n_{24}}.$$

#### SAMPLING BY DRILLING AND PUNCHING.

Clearly, the taking of a sample from a plate is reduced to a simple operation. A single drill hole in any part of the plate, except the edge zone, through the full thickness of the plate, will yield a correct sample. Although a drill is required for an alloy that is hard, a punch will answer the same purpose for one that is soft.

#### SAMPLING BY SAWING.

A saw sample can not be taken from a plate without first cutting through the edge zone. This edge zone, in its vertical section shown in the cross section of figure 12, has been described to be the area from the side  $AA'$  to the line  $EE'$ . From the latter line must be imagined adjoining horizontal layers of the plate such as those shown in the horizontal section of figure 12. It has been explained that the cut from  $AA'$  to  $EE'$  yields a correct sample. The cut carried further to the line  $HH'$ , or to any other vertical line, or through the whole plate will not change the contents of the sample, for any part of such a cut, between any two vertical lines, is a correct sample of itself, answering all the theoretical requisites that have been demonstrated.

#### SAMPLING BY GOUGING OR CHIPPING.

From all that has been demonstrated, it should now be plain that any method of sampling that does not include in the sample all the elements of diffusion in a bar or plate in their proper proportion can not yield a theoretically correct sample. Such methods have been widely practiced in what is known as gouging and chipping, by which parts lying closely to the surface of the casting only could be obtained. These methods should be debarred entirely from use.

### USE OF TEMPLETS IN SAMPLING.

#### ADAPTATION OF THEORY TO PRACTICE IN SAMPLING.

Everything that has thus far been considered has been according to purely theoretical principles, based on hypothetical or ideal conditions. It was, for example, assumed that there existed uniform density in the bars and plates, equal absorption of heat at all points of a surface, and the consequent uniformity of composition of an alloy along certain planes. It was reasoned in this manner with the

belief that if an ideal condition is clearly and perfectly comprehended it would indicate the way to apply the most effective methods to any real or practical problems. Without a working hypothesis the practitioner gropes in the dark or works by rule-of-thumb methods. However, in practice a theoretically correct method may often be modified to allow greater economy, the modified method yielding results of such approximate truth that any errors fall within the accepted limits of accuracy.

In reality alloy or bullion bars and plates, in their inner structure of varied composition, do not present such geometric regularity as characterizes the graphic illustrations. Any one who has seen the chilling of a red-hot molten metal or alloy in a fairly large and open mold will have observed that, when freezing has started there soon appear regions of various degrees of redness; first there are large pools of light red (still liquid) surrounded by fringes of darker red (solid), the proportion of the two gradually changing. All this shows an uneven distribution of temperature due, chiefly, to the interaction of the molten stream and the cold mold. Where the molten stream and the splashings impinge on the cold mold, the mold is heated to a greater degree than where the molten alloy rests more or less quietly. Therefore, it is seen that the molten alloy first freezes through the whole thickness of the casting in streaks more rapidly than in other parts, thus disturbing the regularity of diffusion from top and bottom, in fact causing, to some degree, horizontal diffusion in many parts of the casting and consequent differences in composition throughout the horizontal extent of the alloy or bullion. However, if a number of plates are cast in molds of identical dimensions it could not readily happen that the inequalities would occur in the same relative locations in every plate. It is far more likely that they would change from plate to plate and that the average constitution of a multiplicity of plates would be far more regular than that of any single plate. Proof of this is embodied in the record embraced in Plate I (p. 62). The density of castings will also differ in their various parts, owing to differences in composition and to the formation of blowholes.

On account of the characteristics of any single bar or plate, as described above, a sample consisting of any one cut or drill hole would be unreliable. Instead, various plans have been devised for a more or less regular distribution of cuts or drill holes over an entire surface of a bar or plate. Such a plan when laid out on a sheet of paper or iron, or on a board, is called a templet, or template.

In actual practice, a sample lot is generally made up of many pieces, gold bullion probably being an exception, and in order to obtain a general sample of such a lot, usually only one cut or one drill hole in each sample bar or plate is made, and by making the

cuts or drill holes in consecutive order of their location on the templet one average surface of the total number of sample bars or plates, or a multiple thereof, is covered.

**TEMPLET FOR SAMPLING BY SAWING.**

According to Ledoux,<sup>a</sup> the sampling of copper bullion by sawing was first practiced in England, and Ledoux recognized sawing to be an ideal method. The five-bar templet, illustrated in figure 17, was adopted at that time. There can be little doubt but that the cuts 2, 3, and 4 are ideal samples of the zones b, c, and d; but if the zones a and e be the end levels of

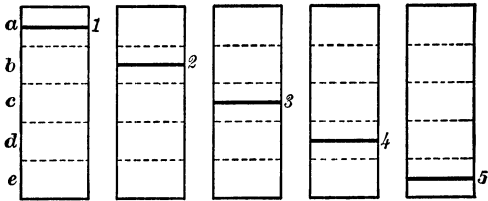

FIGURE 17.—Five-bar templet for English method of sampling by sawing.

the bars, then the cuts 1 and 5 can be only approximate samples of these parts, because, as has been seen in our analysis, a cut must be made at a right angle to an edge, not parallel, to yield a theoretically correct sample. The nearest approach to a theoretically correct templet for sampling bars by sawing is given in figure 18. This

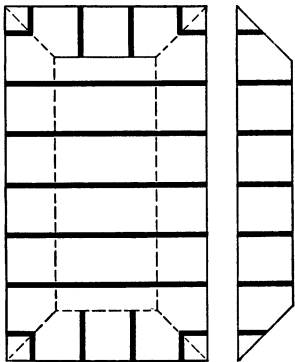

FIGURE 18.—Ideal templet for sampling bars by sawing.

covers the whole surface of the bar, but it naturally could be reduced to one-half or a quarter of that surface.

The sampling of copper bullion by sawing is also practiced in other countries. The method at the Cananea Works, Mexico, is described<sup>b</sup> as follows: "Copper bars are sampled with a series of six parallel saws held in a framework. The bar is inserted and cut halfway through. An electric attachment rings a bell notifying the attendant that the saw should be stopped. The bar is then turned over and cut on the other side halfway between the first cuts. The device saves considerable labor and gives a more accurate sample than the rip saw that was formerly used." Here the whole templet is applied to one bar.

At some of the American company's smelters the copper bullion is sampled by a method devised by Morse.<sup>c</sup> The method involves

<sup>a</sup> Ledoux, A. R., The sampling of argentiferous and auriferous copper: Jour. Canadian Min. Inst., vol. 2, 1899, p. 108.

<sup>b</sup> Engineering and Mining Journal, Sampling copper at Cananea. Vol. 99, 1910, p. 640.

<sup>c</sup> Morse, W. S., Personal communication.

casting from a molten charge (furnace or converter), a flat ring or low cylinder, and reducing to sawings two sectors on the same diametral line (fig. 19). These two sectors will always represent the average thickness of the cylinder, and in all probability the average composition. The sample is, therefore, an ideal one of the cylinder, but the method offers the same pitfalls that have been demonstrated for sampling by shotting.

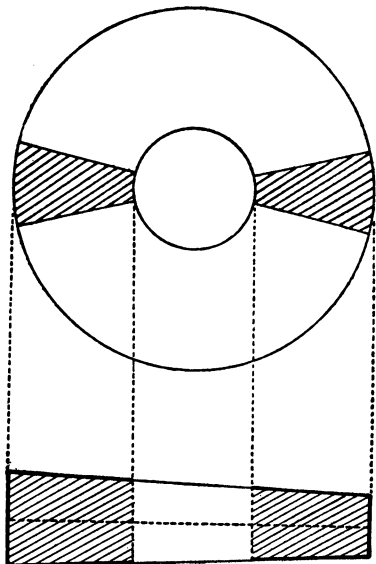

FIGURE 19.—Hollow cylinder of bullion sawed for sample taken according to Morse method.

This suggestion has found extensive recognition, and it has been discovered, incidentally, that the drilling of comparatively irrationally shaped bars according to a templet with an adequate number of holes will yield samples of an approximate accuracy that is quite sufficient for ordinary commercial transactions.

Raht<sup>b</sup> tells us that a system for punching lead-bullion bars has long been in use and is analogous to the five-bar system of sawing as practiced in England. One hole is punched in every bar and the five are equally spaced along the diagonal line, as shown in figure 20.

#### TEMPLER FOR SAMPLING BY DRILLING.

Sawing, without doubt, is a much more expensive operation than drilling. But, as we have clearly seen, drilling does not meet the requirements for theoretically correct sampling of bars, and the prejudice against that method has been long and deep-seated. To overcome the former and to eliminate any reasons for the latter, the author, nearly 20 years ago, advocated the introduction of relatively thin plates in place of the time-honored bars or pigs.<sup>a</sup>

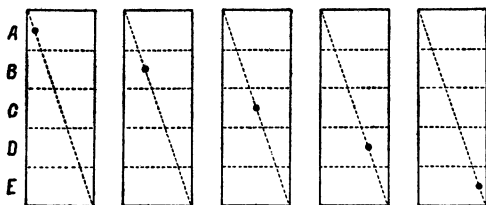

FIGURE 20.—Five-bar templet for sampling by drilling or punching, five-bar method.

<sup>a</sup> Keller, Edward, The distribution of precious metals and impurities in copper and suggestions for a rational mode of sampling: *Trans. Am. Inst. Min. Eng.*, vol. 27, 1897, p. 106.

<sup>b</sup> Raht, A., The distribution of silver in lead bullion, and the different methods of sampling: *Min. Ind.*, vol. 3, 1894, p. 414.

The templet for drilling copper-bullion bars, as adopted and described by Ledoux<sup>a</sup> in 1899, has three rows of six holes and covers one-half of the surface of the bar. Ledoux at that time showed the inadequacy of a five-hole templet for sampling copper-bullion bars by drilling (see fig. 21). He compared that method with the method by sawing. The results of his experiments are given in Table 7 following. As the saw samples are to be considered correct, and as the results obtained from samples taken by sawing do not agree with those obtained from drill samples, it follows that the results by the drilling method are incorrect. If in the lead industry the five-bar punching method has given better satisfaction, such a result can be attributed only to the fact that in the smaller lead-bullion bars the degree of heterogeneity is far less than in the usual sizes of copper bars.

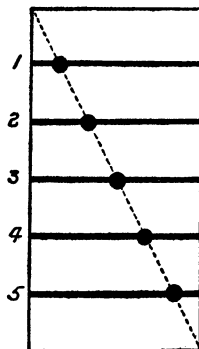

FIGURE 21. — Five-bar templet for sampling by drilling and by sawing. After Ledoux.

TABLE 7.—Results of analyses of samples obtained by drilling and by sawing, five-bar method.

[Silver and gold given in ounces per ton.]

| Sample No.   | Lot A.           |       |                |       | Lot B.           |       |                |       |
|--------------|------------------|-------|----------------|-------|------------------|-------|----------------|-------|
|              | Drilled samples. |       | Sawed samples. |       | Drilled samples. |       | Sawed samples. |       |
|              | Silver.          | Gold. | Silver.        | Gold. | Silver.          | Gold. | Silver.        | Gold. |
| 1.....       | 108.6            | 5.63  | 107.0          | 6.01  | 38.3             | 0.16  | 32.7           | 0.18  |
| 2.....       | 124.4            | 6.20  | 116.3          | 6.33  | 48.8             | .19   | 45.7           | .22   |
| 3.....       | 137.1            | 6.53  | 117.2          | 6.30  | 52.0             | .16   | 44.1           | .22   |
| 4.....       | 126.2            | 6.33  | 122.3          | 6.14  | 44.2             | .16   | 49.0           | .19   |
| 5.....       | 115.3            | 6.14  | 110.4          | 5.97  | 39.0             | .16   | 32.7           | .18   |
| Average..... | 122.3            | 6.17  | 114.7          | 6.15  | 44.5             | .165  | 40.8           | .198  |

**TEMPLET SECTIONS FOR DRILLING AND PUNCHING SHOULD BE SQUARES OR THE CLOSEST POSSIBLE APPROACH THERETO.**

As previously stated, the locations for drilling or punching samples are distributed over the whole average surface of a given number of bars or slabs, because an uneven distribution of the constituents over their horizontal extent is assumed. Therefore, to be theoretically correct, the distribution of the templet sections must be made in such a way that every part of the surface is represented in them in the

<sup>a</sup> Ledoux, A. R., *Loc. cit.*

proper proportion. In figure 22, A, there are the drill-hole cylinders *D*, which represent as samples merely the larger cylinders *C*. These larger cylinders *C* meet in two directions, leaving as unrepresented in the samples the spaces *X*. However, if all cylinders *C* are correctly represented by the drill-hole cylinders *D*, it may then be assumed to be highly probable that the parts *X* would yield a sample of the same contents, or that they, too, are correctly represented by the cylinders *D*. Deviating from the square templet section it is

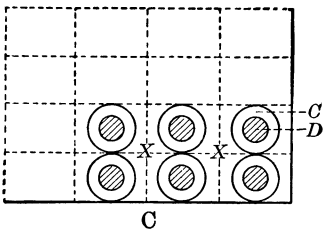
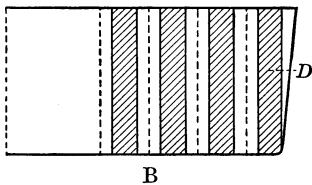
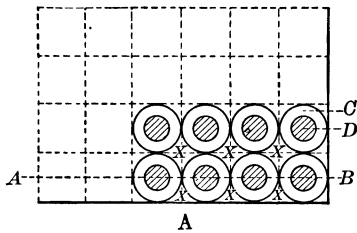

FIGURE 22.—Views showing why templet sections should be approximate squares. *A*, templet with square sections; *B*, section through *AB* in *A*; *C*, templet with rectangular sections.

seen, as in figure 22, *C*, that cylinders *C* meet in only one direction and that the unrepresented spaces *X* increase with the length of the rectangular sections of the templet. It is self-evident that such unequal representation by the drill-hole cylinders can not yield correct samples. It further follows that no templet with a fixed number of sections can be correctly applied to all bars or plates. The sections must be squares or the closest possible approach thereto, and their number must vary according to the size or character of the bars or plates. In similar manner it might be shown that the holes must be drilled vertically through the bars or parallel to each other.

#### SIZE OF TEMPLIET SECTIONS.

Regarding the size of the templet sections no rigid rule can be laid down. As is shown hereafter, with large plates it is necessary to drill only one hole in the center or in any other one location, a sufficient distance from the edge, in a sufficient number of plates, to obtain a correct sample of a lot.

#### TEMPLIET FOR WHOLE, HALF, OR QUARTER BAR OR PLATE.

The views in practice differ as to whether the templet should cover the whole or one-half or one-quarter of the surface of the bars or



plates. When the latter are rectangular and otherwise symmetrical in shape, there can be no doubt that theoretically one half of any bar or plate is absolutely equal to the other half, or that one quarter is equal to each of the other three quarters. In reality there may arise the question of differing thickness, owing to an inclined position of the mold when the bars or plates are cast. If a single bar of such varying thickness were to be sampled it would be necessary to cover its whole surface with a templet, for the diffusion and the consequent composition could not be the same in the several halves or quarters. When many bars are sampled they have generally been shuffled much, and it may be taken for granted that the several quarters or halves bear no distinguishing marks. It is consequently a matter of expediency for other reasons to choose between the whole, the half, and the quarter templet. In general it may be said that when there are not enough bars or plates to go around for a whole templet the safest practice is to use the half templet, or, if the number be insufficient for the latter, to apply the quarter templet.

It may here be remarked that at least one large firm objects to having bars or plates drilled along their center lines. It does not seem possible to sustain this objection on theoretical grounds, and practical examples will show that it has no justification. The whole or the half templet may or may not have the holes along the center line, whereas the quarter templet can not have them there, all of which is indicated in the figures.

#### TEMPLET FOR SAMPLING CIRCULAR CASTINGS BY DRILLING.

Under the discussion of the Morse method of sampling there has been given a description of how to take a correct sample from a hollow cylinder by sawing out two opposite sectors. Heretofore, the round cake or cylinder usually has been sampled by drilling a series of holes along the diametral line, and it will now be seen that this method can not yield a correct sample. It is necessary only to remember, as stated in the remarks on diffusion, that the composition of an alloy cylinder varies radially from the center to the periphery, or vice versa. The circular cross section of the cylinder may be laid out into a central circle, with the radius  $r$ , and the remainder of the area into circular concentric zones, each of the width  $r$ . The average composition of any sector unit of any of the zones should theoretically be the same as the average composition of the whole zone. One drill hole through the center of each zone should, therefore, yield a correct sample for the whole zone; but as each succeeding zone, from the center outward, increases in area, so do the corresponding hollow cylinders increase in volume or weight in the same proportion. Consequently, the central cylinder and the

concentric hollow cylinders and their single drill-hole cylinders can not possess the correct weight ratios for a combined sample.

It follows that the number of drill holes through the several parts of the cylinder must have the same relation as the respective volumes of these parts. The volume of each part, however, is proportional to the area of its cross section, the latter being the central circle and the concentric zones, and it remains to find the areal relations of the parts. By elementary geometric computation it is proven that with the area of the central circle as a unit, the area of the successive zones (width=constant= $r$ ) will be the successive odd-number multiples of the unit. For the ideal templet, therefore, there must be the following number of holes, starting from the center, 1, 3, 5, 7, 9, 11, 13, etc., the number of holes for any templet being equal to the square of the number of zones; of course, any multiple of these numbers could be used equally well.

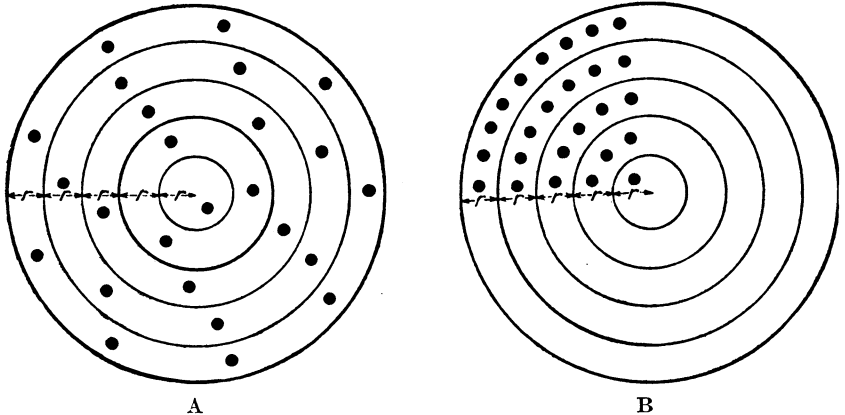

FIGURE 23.—Templets for sampling castings of circular cross section by drilling.

For sampling a single round cake or cylinder, the templet may be so arranged that the holes are equally spaced along the center circle of each zone, as shown in figure 23, A, or they may be arranged in a sector, as shown in figure 23, B, and two opposite sectors may be drilled analogous to the procedure in the Morse method of sawing. In sampling a large number of pieces in which each receives only one hole, it is a matter of no consequence how the holes are arranged in the templet, provided only that the proper number are placed on the center circle of every zone.

#### PROPORTION OF PIECES TO BE TAKEN FOR SAMPLING A LOT.

If bullion is of high value and the character of the distribution of its constituents is unknown, or if its heterogeneity is known to be great, the only sure way of taking a representative sample is to saw, drill, or punch every piece, the templet sections being applied con-

secutively from piece to piece. In the copper industry, especially in the works with great production, this is rarely done. In such works 50, 25, or 20 per cent of the bars or plates is sampled. For mere control work the figure may drop as low as 10 per cent. The choice of any one of these percentages must depend on the comparative uniformity of the material in composition and physical character. The templet is applied irrespective of lots, the sections being applied in continuous consecutive order. Another practice that is observed is to choose the sample pieces not according to the strict percentage numbers but according to the number of holes in the templet, or a multiple thereof.

### SAMPLING LOT OF BARS OF DIFFERENT SIZES.

Two bodies of equal volume and of equal density will have equal weights. The volume is the product of three dimensions. The example of the three dimensions being equal in the several bars or plates may properly be left out of consideration and the case with one variable considered.

Designating the volumes of the two bars as  $V$  and  $V_1$ , or the weights as  $W$  and  $W_1$ , and the dimensions of one as  $A$ ,  $B$ , and  $C$ , and those of the other as  $A$ ,  $B$ , and  $D$ ,  $C$  and  $D$  being the different thicknesses, there follows in algebraic expression:

$$\begin{aligned} V &= A \times B \times C \\ V_1 &= A \times B \times D \\ \text{or, } \frac{V}{V_1} &= \frac{C}{D}, \end{aligned}$$

and substituting weight for volume,

$$\frac{W}{W_1} = \frac{C}{D},$$

which means that the weights of bars or slabs with varying thicknesses but with equal surfaces are proportional to the thicknesses, and as all the drill holes have equal cross sections, the weights of the samples, too, are proportional to the thicknesses of the bars or slabs. Designating the weights of the samples as  $w$  and  $w_1$ , it is found that

$$\frac{W}{W_1} = \frac{w}{w_1},$$

the weight requisite for correct sampling. It follows that with bars or slabs of equal surfaces and differing thicknesses, one drill sample or an equal number of these from each bar or slab may be united to a common sample.

When there are two differing dimensions of the bars or slabs, the three dimensions of the one may be designated as  $A$ ,  $B$ , and  $C$ , and those of the other as  $A$ ,  $D$ , and  $E$ , when

$$V = A \times B \times C$$

$$V_1 = A \times D \times E$$

or,

$$\frac{V}{V_1} = \frac{B \times C}{D \times E}$$

or,

$$\frac{W}{W_1} = \frac{B \times C}{D \times E}$$

which means that the weights of the two bars are proportional to the areas which are the products of the two differing dimensions. In order to obtain drill samples proportional in weight to these bars it would be necessary to employ separate drills, whose cross-sectional areas would have the relation  $B \times C : D \times E$ , which would be impracticable. Consequently the single drill samples from a number of bars, differing in two dimensions, can not be united into a common sample. It is superfluous to examine the case of three differing dimensions.

When in practice a common sample of pieces of several sizes is required, the most reliable procedure is to separate the sizes, ascertain their gross weights, sample each size separately according to the best adapted templet, and prepare the common sample by weighing and uniting the parts in proportion to the gross weights of the pieces of each size.

### RESULTS OF SAMPLING EXPERIMENTS.

The concrete results of experiments presented below are not thought to cover all possibilities or conditions that may present themselves at various works, but they are designed to serve as a general guide in the sampling of any metallic material. The same results will also serve for a more complete illustration and substantiation of some of the theoretical expositions in previous sections of this report.

### GREAT PRODUCTION OF COPPER BULLION.

Most of the experimental data given in this report are based on copper bullion, because that material was the most available. Moreover, data based on copper are advantageous for other reasons. Among the metallic metallurgical products in the United States copper bullion, in bulk and value, is second only to pig iron in annual output. According to the statistics of mineral production (chart) of the United States Geological Survey for the year 1912, the figures are: Pig iron, \$420,563,388; copper, \$205,139,338; silver, \$39,197,500; gold, \$93,451,500. Much of the silver and gold is originally associated with the copper, and the bullion in its totality, therefore, should be sampled in order that accurate determination may be made of the commercial value of its constituents.

**TECHNICAL DIFFICULTIES IN SAMPLING COPPER BULLION.**

Again, some copper bullions offer technical difficulties in sampling not found with other bullions. In a few instances it is found that black copper has a matte cover. A proper sampling can be performed only by a thorough separation of matte and metal and the sampling of each separately by the proper methods. A minor difficulty in sampling copper bullion has already been extensively referred to, and is due to irrational shapes of castings and to their great heterogeneity. As a major difficulty may be mentioned the rough upper surface of all gas finished converter copper bars and slabs. These rough surfaces are caused by the physical characteristic of the molten copper to retain large volumes of the sulphur dioxide gas in solution and to give off this gas upon cooling and freezing. If the gas escaping from the interior encounters a frozen surface that is too strong to be broken, it will form cavities or so-called blisters beneath, or, if the gas raises and breaks the crust, there will be formed crater-shaped excrescences.

**ENRICHMENT OF UPPER LAYERS OF CONVERTER-COPPER BARS.**

The uppermost layers of these rough converter-copper bars and slabs always show an enrichment in silver and, to a lesser degree, in gold, as compared with the parts adjoining below, and distinct from the enrichment by diffusion from the freezing center, which generally lies about one-third of the thickness of the casting below the top, or even closer. The enrichment of the top layer must be attributed to a different cause than the enrichment of the last-freezing parts. As to the enrichment of the top layer, two explanations have been offered, as follows: (1) The author has asserted that toward the end of a converter blow some of the silver compounds become oxidized and insoluble in the molten copper, therefore rising by force of gravity to the surface of the castings. This belief is based on the observation of several metallurgists that the silver volatilization in converting is greatest also toward the end of the blow. (2) A colleague, Mr. P. O. Wels, has offered what is perhaps a more tangible explanation, claiming that all of the surface enrichment is caused by the spray of finely divided molten metallic particles carried to the surface by the gas escaping from the enriched parts that freeze last. It is quite possible that both of the causes mentioned exist.

**ONE-HALF OF BARS SHOULD BE DRILLED WITH SMOOTH SURFACES UP.**

It was at one time customary, for the purpose of sampling, to drill all the sample bars or slabs with the top or rough surfaces up until some one discovered the fact that a sample thus obtained is lower in silver content than one drilled from the bars or slabs with the

under or smooth surfaces up. This fact could be interpreted in two ways—(1) with the rough surface down an excess of the enriched layer might drop into the sample, the piercing drill breaking away more than its own cross-sectional area from the rough surface, thus enriching the sample; (2) with the rough surface up some of the sample of the enriched top can not be recovered, as it is lost in the blisters and crevices of the rough surface, thus impoverishing the sample.

If the first explanation be true, the edge about the drill-hole exit of the rough surface must show that parts not belonging to the drill-hole cylinder have been torn away and gone into the sample; instead, however, on careful observation it was noticed that this did not take place; there was more of a tendency for parts of the drill-hole cylinder of the rough crust, on exit of the drill, to rim or curl over, so that there could have been no undue enrichment of the sample from that source. On emerging from the smooth surface the drill almost invariably makes a clean-cut hole. Seemingly, then, the second explanation is true, namely, that the sample taken by drilling with the rough surface up is impoverished through the loss of some of the richest part of the sample.

COMPARATIVE RESULTS OF SAMPLING BY TOP AND BY BOTTOM DRILLING.

In table 8, following, are incorporated the assay results for silver and gold on eight lots of converter copper of about 100 tons each.

TABLE 8.—*Results of analyses of samples of converter copper slabs drilled with the upper or rough surface up and with the lower or smooth surface up.*

[Results in ounces per ton.]

| Lot No.      | Silver.           |                    |             |        | Gold.             |                    |             |        |
|--------------|-------------------|--------------------|-------------|--------|-------------------|--------------------|-------------|--------|
|              | Rough surface up. | Smooth surface up. | Difference. |        | Rough surface up. | Smooth surface up. | Difference. |        |
|              |                   |                    | Over.       | Under. |                   |                    | Over.       | Under. |
| 1.....       | 41.5              | 42.4               | 0.9         | .....  | 0.300             | 0.300              | .....       | .....  |
| 2.....       | 41.0              | 42.0               | 1.0         | .....  | .311              | .300               | .....       | .011   |
| 3.....       | 43.1              | 44.1               | 1.0         | .....  | .285              | .295               | 0.010       | .....  |
| 4.....       | 42.2              | 44.0               | 1.8         | .....  | .300              | .300               | .....       | .....  |
| 5.....       | 40.4              | 40.2               | .....       | 0.2    | .303              | .316               | .....       | .013   |
| 6.....       | 43.2              | 44.2               | 1.0         | .....  | .365              | .372               | .....       | .007   |
| 7.....       | 43.4              | 43.9               | .5          | .....  | .355              | .339               | .....       | .016   |
| 8.....       | 42.5              | 43.0               | .5          | .....  | .370              | .354               | .....       | .016   |
| Average..... | 42.163            | 42.975             | .812        | .....  | .3236             | .3220              | .....       | .0016  |

The results presented in the table show a distinct gain in silver for the samples drilled with the smooth surfaces of the slabs up, whereas the gold contents are practically equal in the several samples. Each sample slab was drilled for the two samples in places symmetrically located by the templet. These assay results, however, were not considered sufficient proof in themselves as giving the true

relation between the two methods of sampling. Something positive should be proven by the comparative weights of the respective samples.

## EFFECT OF DRILLING METHOD ON WEIGHTS OF SAMPLES.

For that purpose lots 7 and 8 (Table 8) were sampled in four different ways, as follows: (1) By drilling each slab with the rough surface up, and uniting the drillings brought to the top with those brought out with the exit of the drill below; (2) by drilling with the smooth surface up but otherwise proceeding as in 1; (3) by drilling as in 1, but keeping separate any of the sample falling below upon exit of the drill; (4) by drilling with the smooth surface up, but otherwise proceeding as in 3. Methods 3 and 4 were adopted to test the relative weights and values of the samples, as they should be when composed only of the copper belonging to the drill-hole cylinders; that is, by eliminating any parts torn away from the drill-hole rims on exit of the drill. The results of sampling and analysis of the two lots mentioned (Nos. 7 and 8) are given in Table 9, following:

TABLE 9.—Data regarding effect of drilling method on weight of samples.

[Samples drilled from converter-copper slabs.]

## WEIGHTS OF SAMPLES, POUNDS.

| Lot No.    | Slab with rough surface up.         |                                 |                                     | Slab with smooth surface up.        |                                 |                                     |
|------------|-------------------------------------|---------------------------------|-------------------------------------|-------------------------------------|---------------------------------|-------------------------------------|
|            | Entire sample taken in regular way. | Drillings collected on surface. | Drillings falling on exit of drill. | Entire sample taken in regular way. | Drillings collected on surface. | Drillings falling on exit of drill. |
| 7.....     | 31.250                              | 28.250                          | 3.094                               | 34.000                              | 29.250                          | 3.125                               |
| Total..... |                                     | 31.344                          |                                     |                                     | 32.375                          |                                     |
| 8.....     | 22.750                              | 21.500                          | 2.156                               | 25.625                              | 24.125                          | 2.156                               |
| Total..... |                                     | 23.656                          |                                     |                                     | 26.281                          |                                     |

## SILVER AND GOLD CONTENTS, OUNCES PER TON.

|                            | Silver. | Gold. | Silver. | Gold. | Silver. | Gold. | Silver. | Gold. | Silver. | Gold. | Silver. | Gold. |
|----------------------------|---------|-------|---------|-------|---------|-------|---------|-------|---------|-------|---------|-------|
| 7.....                     | 43.4    | 0.355 | 44.8    | 0.343 | 33.5    | 0.295 | 43.9    | 0.338 | 43.3    | 0.333 | 52.5    | 0.347 |
| Average <sup>a</sup> ..... |         |       | 43.68   |       |         | .333  |         |       | 44.19   |       |         | .334  |
| 8.....                     | 42.5    | .370  | 43.4    | .340  | 30.7    | .293  | 43.0    | .310  | 42.3    | .320  | 53.9    | .365  |
| Average <sup>a</sup> ..... |         |       | 42.24   |       |         | .336  |         |       | 43.25   |       |         | .324  |

<sup>a</sup> The average assays were obtained by apportioning individual assays according to the respective weights of the samples.

As shown in the table, for each of the two lots there were four complete samples, two drilled with the rough surface of the slab up and two with the smooth surface up. The total weight of each pair of samples was almost identical; but every sample drilled from the slab with the smooth surface up was heavier than the similar sample from the slab with the rough surface up. Comparing those samples in which the drillings were collected in two parts—that is, the sam-

ples in which those drillings carried to the upper surface and those emerging with the exit of the drill were weighed and assayed separately, so that any undue additions by breakage of the drill-hole rim upon exit of the drill were kept from the great bulk of the drillings—it was found that the main samples drilled with the smooth surface of the slab up were the heavier. It thus follows conclusively that parts of the samples drilled with the rough surface of the slab up may be lost in the blisters and crevices of that surface, and that the samples drilled with the smooth surface up do not obtain an undue part of the enriched surface. The detailed assays in the table sustain the conclusion.

In commercial practice, at least at a number of the copper refineries, the refiner and the seller of copper have adopted a compromise as to the sampling method, agreeing to the alternate drilling of one lot with the rough surface up and one with the smooth surface up. It must be stated, however, that bars with a pronounced bevel can not have the bevel drilled with the smooth surface up, it being impossible to force the drill into the metal at the angle of the bevel. Such a bevel must be drilled with the rough surface up.

#### EFFECT OF DIFFUSION PHENOMENA.

Numerous examples of the diffusion phenomena especially pertaining to copper-silver bullion have already been seen. For a general review of this subject, relating to diverse bullions, the reader is referred to Neumann.<sup>a</sup> Reference has also been made to the sampling results incorporated in Plate I as showing the irregularities of distribution of the silver and gold content in the horizontal direction of a copper-bullion slab and as indicating that the effect of these irregularities is much reduced when the average assays of each location are taken from a multiplicity of slabs. Each slab is laid out in zones, all points of each zone being equidistant from the edge of the slab. The differences in silver or gold content among the several drill samples in each zone are a measure of the irregularities. The plate indicates that the maximum difference between the silver content in two points in one zone in the single slab is reduced to one-half the magnitude in the maximum difference in the 10 slabs. A similar reduction would, without doubt, continue with an increased number of slabs. If the differences in one zone in the single slab are small, there can, of course, be only a small reduction in the corresponding figures for the 10 slabs.

The single slab represented in Plate I was drilled in one quarter by a templet of 78 holes; it was planed through (equal to saw cutting) along three lines, and each of its quarters was melted and shot

<sup>a</sup> Neumann, B., Die Entmischung der Legierungen, u. s. w., Chem. Zeit., Jahrg. 21, 1897, p. 1024.



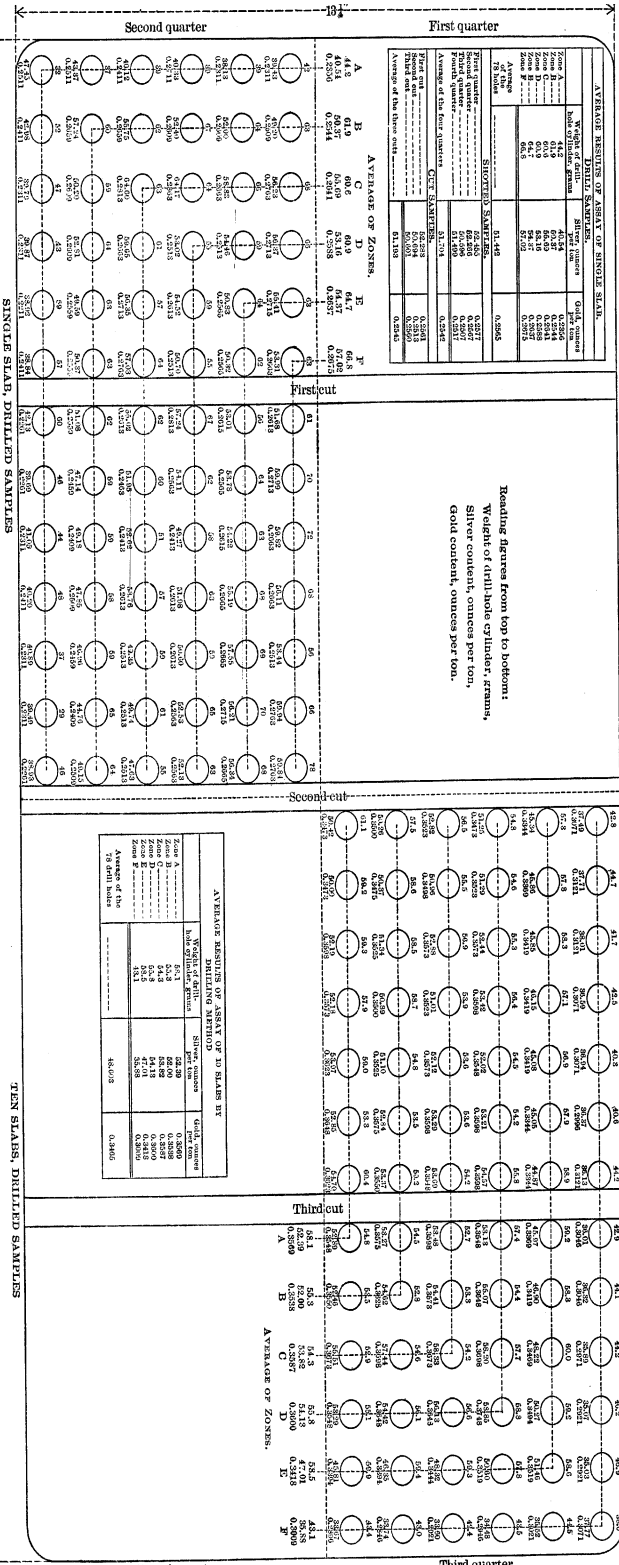

**AVERAGE RESULTS OF ASSAY OF SINGLE SLAB.**

| WEIGHT OF DRILLING METHOD | SILVER, ounces | GOLD, ounces  |               |
|---------------------------|----------------|---------------|---------------|
| 41.6                      | 41.64          | 0.2854        | 0.2854        |
| 41.7                      | 41.64          | 0.2854        | 0.2854        |
| 41.8                      | 41.64          | 0.2854        | 0.2854        |
| 41.9                      | 41.64          | 0.2854        | 0.2854        |
| 42.0                      | 41.64          | 0.2854        | 0.2854        |
| 42.1                      | 41.64          | 0.2854        | 0.2854        |
| 42.2                      | 41.64          | 0.2854        | 0.2854        |
| 42.3                      | 41.64          | 0.2854        | 0.2854        |
| 42.4                      | 41.64          | 0.2854        | 0.2854        |
| 42.5                      | 41.64          | 0.2854        | 0.2854        |
| <b>Average</b>            | <b>41.64</b>   | <b>0.2854</b> | <b>0.2854</b> |

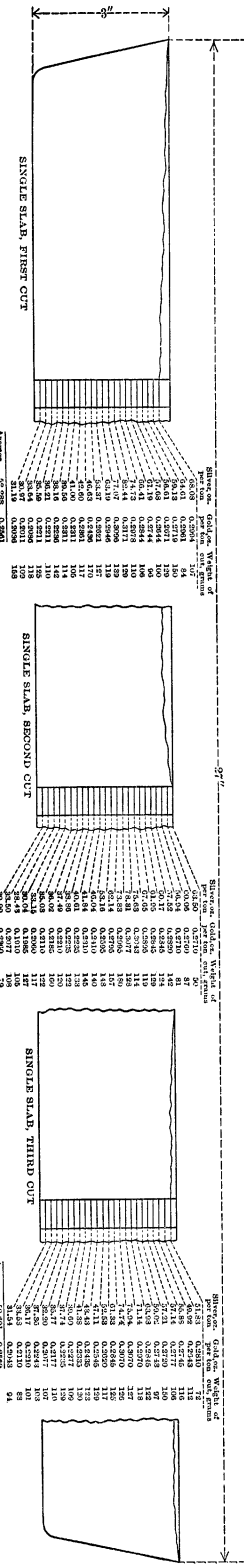

RESULTS OF ASSAY OF SINGLE SLAB AND AVERAGE BULLION, BY DRILLING METHOD, SHOWING DISTRIBUTION OF GOLD AND SILVER CONTENT. AVERAGES ARE CORRECTED ACCORDING TO WEIGHT OF SAMPLE.

sampled. The average assay results for the samples obtained by the three methods were as follows:

*Average results of assay of copper-bullion samples obtained in three ways.*

| Item.                        | Drill samples. | Cut samples. | Shotted samples. |
|------------------------------|----------------|--------------|------------------|
| Silver..... ounces per ton.. | 51.442         | 51.193       | 51.704           |
| Gold.....do.....do.....      | .2565          | .2545        | .2542            |

The results are fairly close to those obtained in ordinary work, and it may be justly left to inference how much the differences between them would have been reduced had 10, 50, or 100 slabs been sampled by the same methods.

All average assays given in this section are correct, having been obtained according to the weights of the individual samples, of which the general sample was made up and to which the average assay refers. All of the figures have been checked. Nearly every assay result for individual samples is the mean of multiple individual determination, many of the latter numbering 10 or more.

The average results of assays of the 78 samples from the 10 slabs were as follows:

|                       |         |
|-----------------------|---------|
|                       | Ounces. |
| Silver, per ton ..... | 48.603  |
| Gold, per ton.....    | .3465   |

The results for the 1 slab and those for the 10 slabs are a clear indication of the considerable differences in silver and gold contents among the individual slabs.

The 11 slabs mentioned above were part of a shipment of 276, of which 55, or 20 per cent, were sampled by drilling according to a templet, with 351 holes, that covered the whole surface of a slab. Each slab received only one hole, and, consequently, only a part, about one-sixth, of the slab surface of the lot was covered by the sampling. The same lot had been shot sampled and assayed at the smelter. The Eastern (refinery) and Western (smelter) results compare as follows:

*Results of Eastern (refinery) and Western (smelter) assays of bullion.*

| Item.                        | Western (smelter) assay of shotted sample. | Eastern (refinery) assay of drilled sample. |
|------------------------------|--|---|
| Silver..... ounces per ton.. | 49.50                                      | 49.79                                       |
| Gold.....do.....             | .34  | .3273                                       |
| Copper.....per cent..        | 99.17                                      | 99.18                                       |

These results are satisfactory for a single lot, indicating that sampling 20 per cent of such slabs is sufficient; the lower results for the 10 slabs decidedly indicate that the sampling of such a small proportion (3.6 per cent) is entirely insufficient.

The results shown in Plate I give important information relative to the character of bars and plates, as defined in a former section. The distribution of the metals in the vertical direction is characteristic of either shape, but the variation is more pronounced in the bars. The distribution of the metals in the horizontal direction, as indicated by the values given for each drill hole, shows that here there is no approach to the ideal plate, although a casting having the dimensions given has always been called a slab or plate. It may be remembered that a plate should have along its edges only a narrow zone in which diffusion has taken place in the horizontal direction. In all the inner area diffusion should have proceeded only in the vertical direction, and in this area the contents of all of the individual drill-hole samples should at least approach the average values for the whole plate or slab. Instead, it is seen in the slab shown in Plate I a distinct increase of the values from the edge to zone C, a decrease in zone D, and again a rise to zone F. But each of the zones D, E, and F show a greater silver and gold content than the average content of the slab, a proof that horizontal diffusion and concentration have reached to the very center of the slab. The slab, therefore, according to this physical characteristic, is a bar. In order to have the pronounced characteristics of a plate, this kind of copper bullion must be cast as a much thinner slab or, with the same thickness, into one with greatly increased horizontal dimensions. It could not be expected to obtain an average sample of a whole slab by drilling it in any one location within the area circumscribed by the edge zone, as would be obtained by so drilling a plate of proper dimensions.

To obtain, by drilling, an average sample from bullion of the shape and dimensions shown in Plate I, the use of a templet with sections 1 inch square remains the most advisable. It is probably immaterial whether the whole, one-half, or one-quarter of the surface is covered thereby.

#### DETERMINATIONS OF SILVER AND GOLD IN COPPER BULLION.

In Plate II is shown another example of a converter slab, almost identical in size and shape with that shown in Plate I. The distribution of silver and gold in the vertical and in the horizontal directions by  $\frac{1}{8}$ -inch cuts is shown. The samples from the cuts were used to the last fraction of an assay ton for the silver and gold determinations, so that the accuracy of the average assays for the whole cuts should be practically absolute. The assays of these parts, therefore,

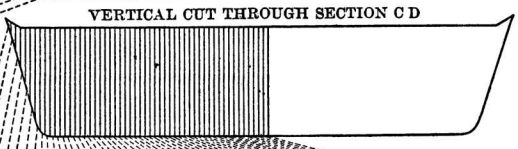
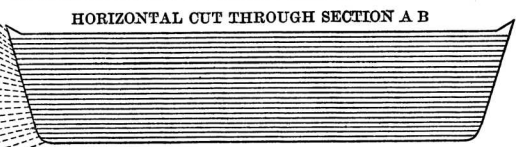
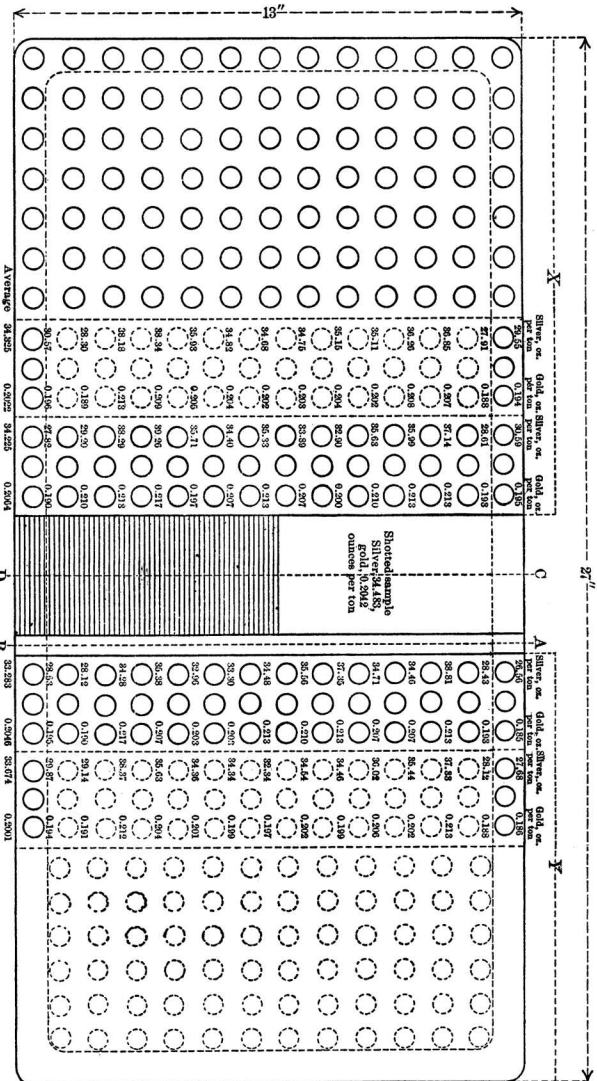

RESULTS OF ASSAYS OF SLAB OF CONVERTER COPPER BULLION SAMPLED IN EIGHT ZONES BY SEVERAL METHODS. AVERAGES ARE CORRECTED ACCORDING TO WEIGHT OF SAMPLE. SOLID CIRCLES INDICATE THAT THE HOLES WERE DRILLED WITH THE ROUGH SURFACE UP; DOTTED CIRCLES INDICATE THAT THE HOLES WERE DRILLED WITH THE SMOOTH SURFACE UP.

| Weight of cut, grams | Silver, ounces per ton | Gold, ounces per ton |
|----------------------|------------------------|----------------------|
| 15                   | 40.10                  | 0.220                |
| 114                  | 49.43                  | 0.220                |
| 72                   | 38.75                  | 0.220                |
| 68                   | 40.02                  | 0.220                |
| 71                   | 45.31                  | 0.220                |
| 80                   | 44.51                  | 0.220                |
| 66                   | 48.25                  | 0.220                |
| 70                   | 47.85                  | 0.220                |
| 82                   | 43.04                  | 0.220                |
| 86                   | 40.28                  | 0.108                |
| 89                   | 36.52                  | 0.210                |
| 74                   | 38.70                  | 0.208                |
| 83                   | 38.28                  | 0.108                |
| 88                   | 29.13                  | 0.106                |
| 72                   | 27.42                  | 0.100                |
| 85                   | 35.11                  | 0.106                |
| 83                   | 24.13                  | 0.175                |
| 49                   | 23.48                  | 0.170                |
| 59                   | 12.42                  | 0.165                |
| 82                   | 20.24                  | 0.165                |
| 82                   | 18.81                  | 0.135                |
| 84                   | 13.18                  | 0.190                |
| Average              | 34.238                 | 0.202                |

NINETY-ONE HOLE SAMPLE Silver, ounces per ton 31.062 Gold, ounces per ton 0.2000

EIGHTY-FOUR HOLE SAMPLE Silver, ounces per ton 31.275 Gold, ounces per ton 0.2003

D CUT SAMPLES Silver, ounces per ton 34.430 Gold, ounces per ton 0.2000

SEVENTY-TWO HOLE SAMPLE Silver, ounces per ton 33.479 Gold, ounces per ton 0.2004

Average Silver, ounces per ton 34.238 Gold, ounces per ton 0.202

present a basis with which to compare the assays of other parts of the slab that were sampled by the less positive method of drilling at 1-inch intervals. The slab was laid out in eight lateral zones, one through *CD* being divided into two parts. By the assay of individual or general samples the silver and gold contents of nine separate parts of the slab were obtained. In drilling six of the zones, three were drilled with the rough surface up and three with the smooth surface up. Unbroken circles indicate that the rough surface was up; broken circles indicate that the smooth surface was up. The average results are tabulated in Table 10 following, and from these comparatively uniform figures from a single slab the inference may again be drawn that had the same zones of many slabs been sampled in like manner, the differences between the results thus obtained would have been accordingly diminished.

TABLE 10.—*Silver and gold contents in zones of converter-copper slab.*

| Zone. <sup>a</sup> | Mode of sampling.                | Silver per ton. | Gold per ton.  |
|--------------------|----------------------------------|-----------------|----------------|
|                    |                                  | <i>Ounces.</i>  | <i>Ounces.</i> |
| X, end.....        | Drilling; rough surface up.....  | 34. 063         | 0. 2030        |
| X, middle.....     | Drilling; smooth surface up..... | 34. 325         | . 2022         |
| X, middle.....     | Drilling; rough surface up.....  | 34. 225         | . 2064         |
| CD.....            | Cutting.....                     | 34. 530         | . 2049         |
| CD.....            | Shooting.....                    | 34. 483         | . 2042         |
| AB.....            | Cutting.....                     | 34. 228         | . 2026         |
| Y, middle.....     | Drilling; rough surface up.....  | 33. 283         | . 2046         |
| Y, middle.....     | Drilling; smooth surface up..... | 33. 674         | . 2001         |
| Y, end.....        | .....do.....                     | 34. 645         | . 2050         |

<sup>a</sup> See Plate II for locations of zones.

The slab represented in Plate II shows more of the character of the true plate than the slab represented in Plate I, as there is no concentration in the center. Two lots of similar copper were sampled in order to ascertain how much two samples would differ in their metal contents if sampled (1) in the regular way, according to a templet covering the whole surface, with 351 sections, each 1 inch square; and (2) by drilling a hole in the center of the same slabs. Lot 1 contained 677, and lot 2, 700 slabs. Twenty per cent of all the slabs was drilled. Lot 1 was drilled with the rough surface up, and lot 2 with the smooth surface up. The Western (smelter) results of assays of shotted samples are also on hand. Table 11, following, contains the tabulated figures. It may be noted that for the drilled samples the results for copper and gold were close and for the silver fairly so. On the other hand the Western (smelter) results for the shotted samples were higher for silver than any of the others and somewhat beyond the commercial limits usually permitted.

TABLE 11.—*Results of assays of samples of converter-copper slabs.*

| Character of sample.                    | Lot No. | Silver per ton.          | Gold per ton.            | Copper.                   |
|---|---------|--------------------------|--------------------------|---------------------------|
| Drilled, general templet.....           | 1       | <i>Ounces.</i><br>37.324 | <i>Ounces.</i><br>0.2375 | <i>Per cent.</i><br>99.19 |
| Drilled, general templet.....           | 2       | 37.249                   | .2492                    | 99.16                     |
| Average.....                            |         | 37.2865                  | .24335                   | 99.175                    |
| Drilled, center of slab.....            | 1       | 37.233                   | .2358                    | 99.16                     |
| Drilled, center of slab.....            | 2       | 37.891                   | .2525                    | 99.22                     |
| Average.....                            |         | 37.562                   | .24415                   | 99.19                     |
| Shotted, Western (smelter) figures..... | 1       | 38.40                    | .2343                    | 99.16                     |
| Shotted, Western (smelter) figures..... | 2       | 38.90                    | .2400                    | 99.24                     |
| Average.....                            |         | 38.65                    | .23715                   | 99.20                     |

## RESULTS OF SILVER DETERMINATIONS BY TWO TEMPLETS.

Figure 24 represents a converter-copper bar or pig, the silver distribution over one-quarter and one-half of its surface, as obtained from drilled samples, being shown. The properly averaged results from the two templets used showed close concordance. The use of a 56-hole templet showed a silver content of 41.81 ounces per ton, and the use of a 40-hole templet showed a silver content of 41.94 ounces per ton.

These figures demonstrate that the drill holes along the center line and the somewhat larger sections in the one templet did not alter the results; in fact, the close agreement between the assays of the two samples may be taken as proof of their correctness. Unfortunately there were no other methods of sampling carried out with this pig.

## RESULTS OF SILVER DETERMINATIONS WITH LARGE NUMBERS OF PIGS.

A further proof of the sufficient accuracy of the methods of sampling similar pigs by drilling was furnished by the results of a test made as follows: A lot of 280 pieces was sampled by drilling one hole in every pig according to a 40-hole quarter templet, all the holes in which were thus used seven times for one sample. The sample showed 40.70 ounces of silver per ton. Then 40 pieces were taken at random, and each of these was sampled with one drill hole, so that each hole in the templet was used only once for a second sample. The sample showed 40.54 ounces of silver per ton.

In another instance of 193 pigs, 48 were drilled for one sample, showing 5.895 ounces of silver per ton, and 145 were drilled for a second sample, showing 6.044 ounces of silver per ton.

The foregoing examples of the distribution of the precious metals in copper bullion have shown a great degree of heterogeneity in

such distribution. This was especially noticeable along the vertical line of the slabs; but even in the horizontal direction, as shown from drill hole to drill hole, the differences were pronounced. Silver

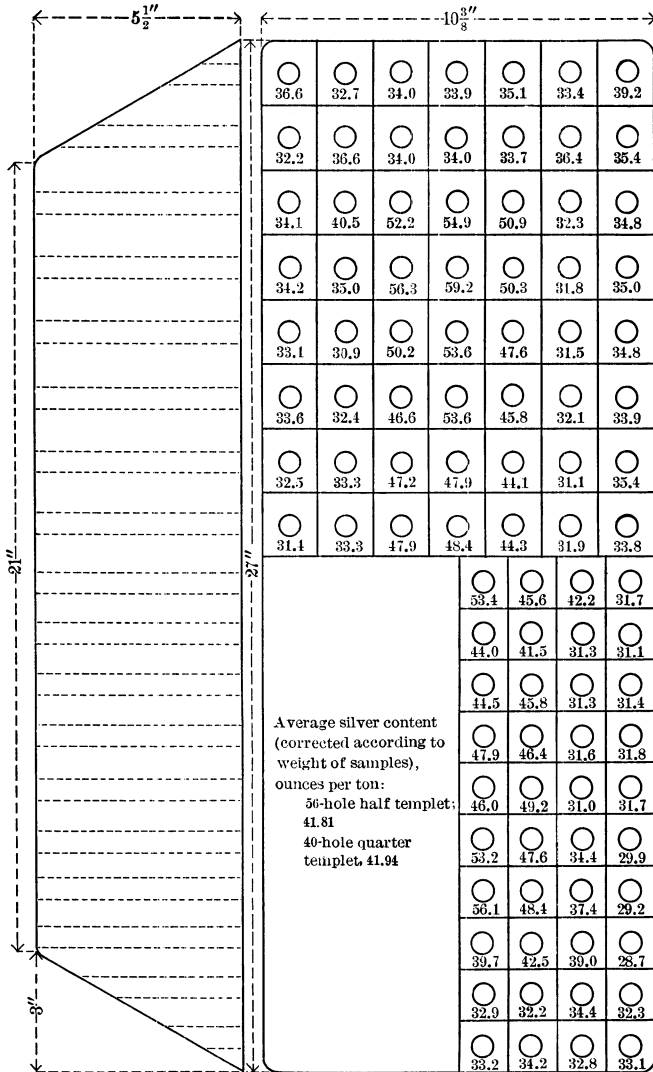

FIGURE 24.—Determination of silver content and distribution in gas-finished converter bar by two templets. Silver, in ounces per ton.

always shows a greater degree of concentration than gold, and for that reason if the sampling method takes proper care of the silver, the gold will also be properly represented. For that reason the gold concentration has not been considered in some of the examples.

## HOW SAMPLING ERRORS OFFSET EACH OTHER.

Owing to the nature of the material under consideration, there always must be differences in the contents of samples. How "plus" and "minus" values will balance each other may be seen in Table 12 following, which shows monthly averages for Western (smelter) shotted samples and assays and Eastern (refinery) drilled samples and assays for gas-finished converter copper.

TABLE 12.—*Monthly average results of assays of Western shotted and Eastern drilled samples of gas-finished converter copper.*

| Month No. | Monthly average copper content. |                          | Difference.    |                | Silver per ton.           |                           | Difference. |             | Gold per ton.            |                           | Difference. |             |
|-----------|---------------------------------|--------------------------|----------------|----------------|---------------------------|---------------------------|-------------|-------------|--------------------------|---------------------------|-------------|-------------|
|           | Western shotted samples.        | Eastern drilled samples. | Over.          | Under.         | West-ern shotted samples. | East-ern drilled samples. | Over.       | Under.      | West-ern shottd samples. | East-ern drilled samples. | Over.       | Under.      |
|           | <i>Per cent.</i>                | <i>Per cent.</i>         | <i>Per ct.</i> | <i>Per ct.</i> | <i>Ounces.</i>            | <i>Ounces.</i>            | <i>Ozs.</i> | <i>Ozs.</i> | <i>Ozs.</i>              | <i>Ozs.</i>               | <i>Ozs.</i> | <i>Ozs.</i> |
| 1.....    | 99.1776                         | 99.3448                  | 0.1672         | .....          | 42.5238                   | 42.5890                   | 0.0652      | .....       | 0.2508                   | 0.2603                    | 0.0095      | .....       |
| 2.....    | 99.1244                         | 99.2932                  | .1688          | .....          | 39.9619                   | 39.9092                   | .....       | 0.0527      | .2320                    | .2456                     | .0136       | .....       |
| 3.....    | 99.1782                         | 99.2731                  | .0949          | .....          | 41.3586                   | 40.7206                   | .....       | .6380       | .2463                    | .2559                     | .0096       | .....       |
| 4.....    | 99.0291                         | 99.2487                  | .2196          | .....          | 40.5680                   | 40.5920                   | .0240       | .....       | .2589                    | .2812                     | .0223       | .....       |
| 5.....    | 98.9552                         | 99.1948                  | .2396          | .....          | 39.8218                   | 40.0597                   | .2289       | .....       | .2675                    | .2890                     | .0215       | .....       |
| 6.....    | 99.1570                         | 99.3513                  | .1943          | .....          | 37.1652                   | 36.9336                   | .....       | .2316       | .2349                    | .2487                     | .0138       | .....       |

Relative to the two sets of results the author makes the following impartial comment: As silver is the metal subject to the greatest variations in the converter copper, the silver assays, as a consequence, furnish the best indication of the accuracy of samples taken by different methods, provided that the silver assays are performed under uniform conditions. In Table 12 the silver results show close agreement, "plus" and "minus" values being equally divided between Eastern and Western samples. The logical conclusion is that Eastern and Western samples are identical for all practical purposes.

In view of the previous statement that if the silver be properly taken care of by the sampling method the gold will also be, the question arises as to why the gold assays are entirely one-sided in the table. Seemingly, the one set of gold-assay results is too high or the other too low. Equally one-sided are the copper-assay results, and to these the same error may be attributed as to those of the gold. It is, however, inconceivable that the drilled samples can be too high in copper, whereas it could readily happen in shotting that the copper could become oxidized, which would depress the copper percentage appreciably, when an equal percentage of the silver and gold contents would vanish within the limits of experimental error.

At the Baltimore Copper Works a test was made with a highly auriferous and argentiferous copper bullion. The gas-finished slab was drilled in 1-inch templet sections covering its whole surface, thus



giving one drilled sample. After the drilling the slab was reduced to sawings; a part of the sawings being used for assaying, and another part melted and cast into thin sample plates, which again were drilled for samples.

The assay results tabulated in Table 13, following, show a fair agreement. It is quite evident that the differences may be as well ascribed to the assays on account of an insufficient number of the latter as to the methods of sampling.

TABLE 13.—*Results of assaying samples of auriferous and argentiferous converter copper.*

| Lot No.      | Drilled sample.           |                         |                          | Sawed sample.             |                         |                          | Thin-plate sample.     |                         |
|--------------|---------------------------|-------------------------|--------------------------|---------------------------|-------------------------|--------------------------|------------------------|-------------------------|
|              | Copper.                   | Silver,<br>per ton.     | Gold,<br>per ton.        | Copper.                   | Silver,<br>per ton.     | Gold,<br>per ton.        | Silver,<br>per ton.    | Gold,<br>per ton.       |
| 1. ....      | <i>Per cent.</i><br>98.89 | <i>Ounces.</i><br>83.25 | <i>Ounces.</i><br>22.345 | <i>Per cent.</i><br>98.73 | <i>Ounces.</i><br>82.70 | <i>Ounces.</i><br>22.440 | <i>Ounces.</i><br>83.4 | <i>Ounces.</i><br>22.38 |
| 2. ....      |                           |                         |                          |                           | 83.40                   | 22.355                   | 83.3                   | 22.39                   |
| 3. ....      |                           |                         |                          |                           |                         |                          | 83.2                   | 22.47                   |
| 4. ....      |                           |                         |                          |                           |                         |                          | 83.6                   | 22.43                   |
| 5. ....      |                           |                         |                          |                           |                         |                          | 83.1                   | 22.36                   |
| 6. ....      |                           |                         |                          |                           |                         |                          | 84.0                   | 22.40                   |
| 7. ....      |                           |                         |                          |                           |                         |                          | 83.5                   | 22.45                   |
| 8. ....      |                           |                         |                          |                           |                         |                          |                        | 22.41                   |
| Average..... | 98.89                     | 83.25                   | 22.345                   | 98.73                     | 83.05                   | 22.3975                  | 83.48                  | 22.411                  |

#### RESULTS OF SAMPLING REFINED COPPER BULLION.

Examples of another class of converter copper bullion will now be considered. Originally this is the same material as that of the foregoing examples, but it has been put through a refining operation in the reverberatory furnace and has been freed of sulphur and sulphur dioxide. This refined bullion forms solid castings and it undoubtedly has a higher freezing point than the gas-finished bullion, although confirmatory data are not at hand. It probably also possesses considerably better heat conduction.

Figure 25 represents a thin slab of refined copper bullion. Diffusion along the vertical axis of this slab, as expressed in silver concentration, is still pronounced. To show the same phenomenon, along the horizontal axis, by drilling, it was necessary to place the drill holes close to the edge. It will be noticed that the average silver assays of all the sets of samples, except those along the edge, show close agreement.

Plate III shows a slab of refined converter copper having dimensions almost identical with the slabs shown in Plates I and II. When the silver assays given for the individual drill holes are noted a marked difference in the character of the two kinds of copper bullion at once becomes evident. In the gas-finished bullion there are pronounced zones of silver concentration, with a difference of 25

ounces in the slab shown in Plate I and of 13 ounces in the slab shown in Plate II between the highest and lowest silver content. In the slab of refined converter copper it is impossible to discern any zones, and the greatest difference between highest and lowest silver is only

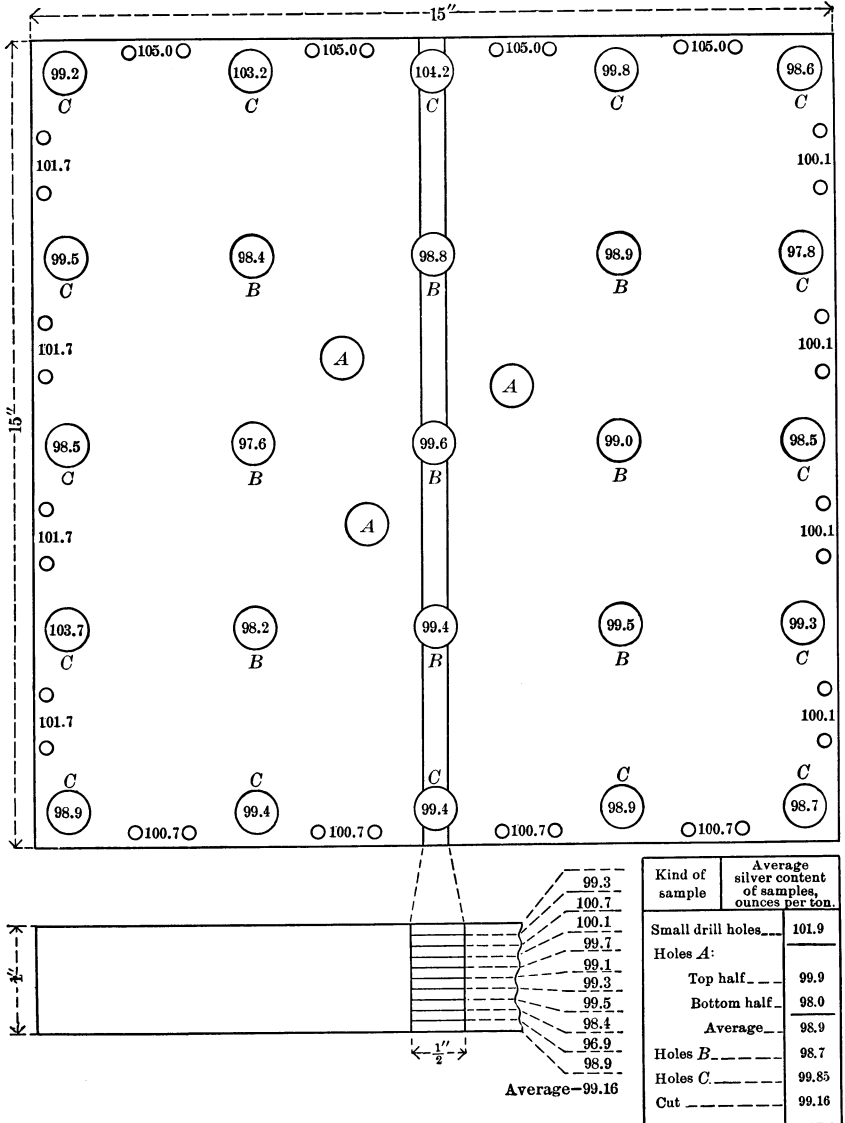
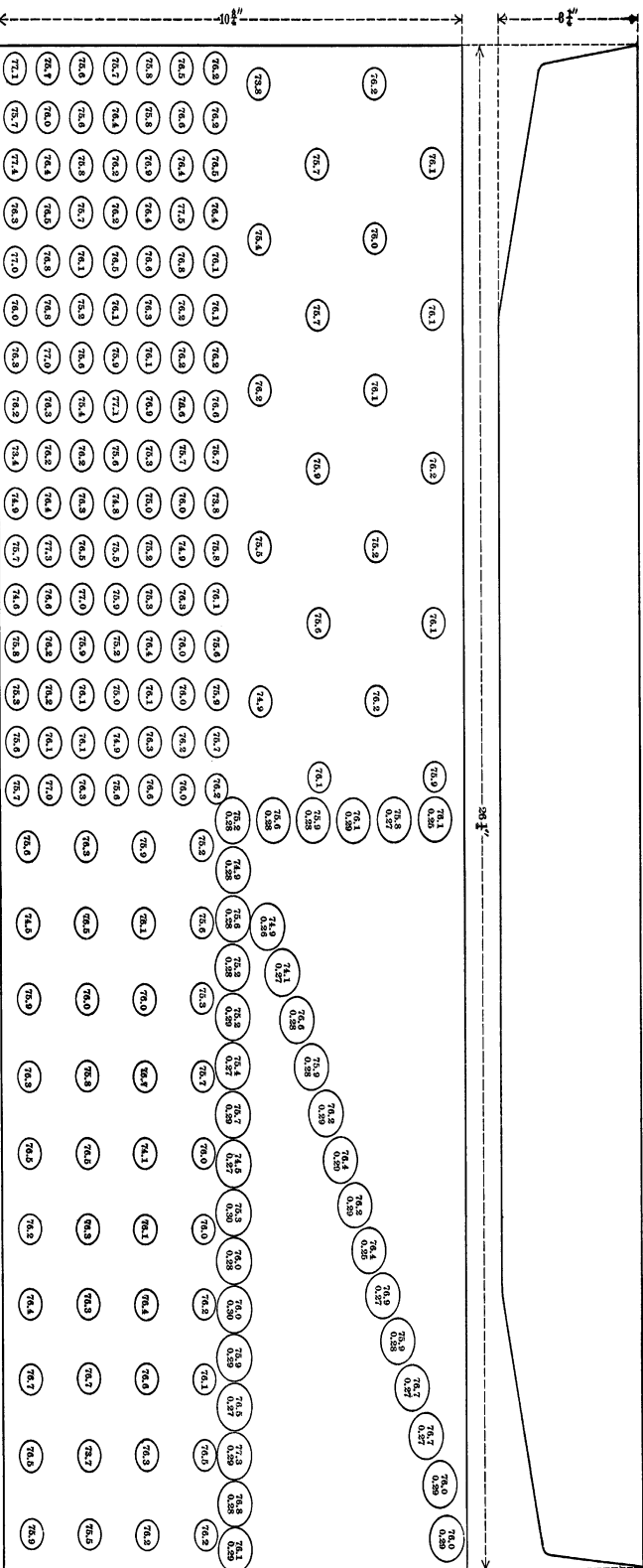

FIGURE 25.—Distribution of silver in thin plate of copper.

4 ounces. The four quarters of this slab were sampled according to separate templets. After the drilling each quarter was melted and thin plate samples were cast. Shotted samples were also taken by pouring the metal directly from the crucible.

Average results of assaying quarter drilled according to 112-hole template, showing silver content in ounces per ton: Average of 112 individual drill-hole samples, 76.04; average of 112 samples combined, 75.50; thin-plate sample, 75.88; shotted sample, 75.82 to 40-hole template (the template adopted in practice) showing silver content in ounces per ton: Average of 40 individual drill-hole samples, 75.98; average of 40 samples combined, 75.95; thin-plate sample, 76.50; shotted sample, 75.86.

Average results of assaying quarter drilled according to 20-hole template, showing silver content in ounces per ton: Average of 20 individual drill-hole samples, 75.75; average of 20 samples combined, 75.72; average of 38 individual drill-hole samples, 75.81; average of 35 samples combined, 75.84; average of 38 individual quarter drilled according to 35-hole template, showing silver in ounces per ton: Average of 38 individual drill-hole samples, 75.94; average of 6 drill-hole samples taken along diagonal line, 75.94; average of 6 drill-hole samples taken along lateral center line, 75.79; thin-plate sample, 75.82; shotted sample, 75.84. The gold content, in ounces per ton, is also shown for the drill-hole samples of this quarter.



RESULTS OF SAMPLING THE FOUR QUARTERS OF A REFINED COPPER BULLION SLAB BY DRILLING. AVERAGE RESULTS BY MELTING AND SHOTTING METHODS ARE ALSO SHOWN.

The results of all the samples are tabulated in Table 14 following; they are all within the generally accepted commercial limits:

TABLE 14.—*Results of assaying samples of slab of refined converter copper.*

| Quarter No. | Number of holes in templet. | Silver per ton.                      |                            |                              |                           | Average.       |
|-------------|-----------------------------|--------------------------------------|----------------------------|------------------------------|---------------------------|----------------|
|             |                             | Average assay of individual samples. | Assay of combined samples. | Assay of thin-plate samples. | Assay of shotted samples. |                |
|             |                             | <i>Ounces.</i>                       | <i>Ounces.</i>             | <i>Ounces.</i>               | <i>Ounces.</i>            | <i>Ounces.</i> |
| 1.....      | 112                         | 76.04                                | 75.50                      | 75.88                        | 75.82                     | 75.81          |
| 2.....      | 20                          | 75.75                                | 75.69                      | 76.18                        | 75.88                     | 75.88          |
| 3.....      | 40                          | 75.98                                | 75.93                      | 76.26                        | 75.96                     | 76.03          |
| 4.....      | 35                          | 75.83                                | 75.93                      | 75.82                        | 75.84                     | 75.86          |

#### RESULTS OF SAMPLING REFINED-COPPER ANODES.

Figures 26 and 27 show comparatively large, thin plates of refined converter copper in the form of anodes. Figure 26 also shows the regular working templet, with 3-inch templet sections, as applied to the lower surface of the anode, the anode having been drilled according to the templet. The anode was also drilled along a diagonal line. Another part of the anode, through AB, was cut in  $\frac{1}{8}$ -inch layers through the edge zone along the horizontal line; the remainder of the same part was cut in equal layers along the vertical line. Along the horizontal line the variation in silver content is only about 2 ounces. The variation along the vertical line is, as would be expected, much greater, being about 11 ounces.

As regards the anode shown in figure 26, particular attention was paid to the sampling of one of the lugs or hangers, for the reason that at the refinery it may happen that a sample anode is taken to the electrolytic tank before it is sampled and that there would be nothing left intact except the lugs. The lug is distinctly of the bar character, so that logically a cut through it should have given a correct sample of this part, as also of the whole anode, whereas a single drill hole in all probability would not have given the same result. The results obtained from a cut substantiated this supposition. Three drill holes are a sufficient substitute for a continuous cut, which is also shown in the figure. The Western (smelter) results of shot sampling the furnace charge from which this anode was derived were also available, and are presented in figure 26. The averages from a single plate show a close agreement, and with them as a basis the conclusion may be drawn that from a homogeneous furnace charge a correct sample by drilling a single anode according to regular templet is obtained; or, having only a lug of the anode, a correct sample also may be obtained by making cross-sectional cuts with a saw or planer, or with three drill holes.

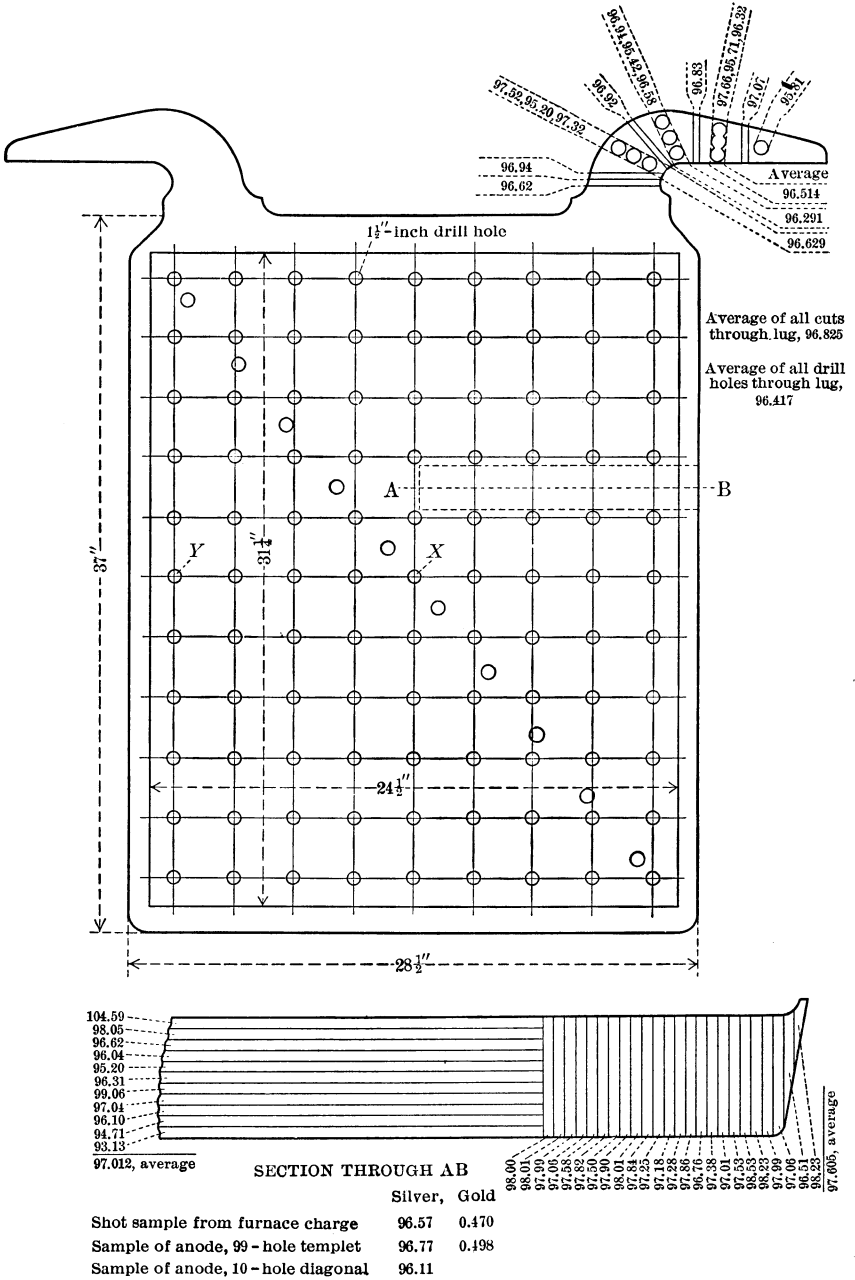

FIGURE 26.—Silver distribution in furnace-refined copper bullion anode. Silver given in ounces per ton.



sampling otherwise being as in 1; (3) each anode was placed with the lower surface up and each was drilled through the geometric center (see *X*, figure 26); (4) each anode was placed with the lower surface up and each was drilled through the center of the templet section (see *Y*, figure 26). The averaged results of a dozen determinations for each sample are found in Table 15, following:

TABLE 15.—Results of assays of samples of refined-copper anodes.

| Source of sample.                               | Copper.          |                | Silver per ton. | Gold per ton.  |
|---|------------------|----------------|-----------------|----------------|
|   | <i>Per cent.</i> | <i>Ounces.</i> | <i>Ounces.</i>  | <i>Ounces.</i> |
| 99-hole templet; upper surface of anode up..... | 99.269           | 80.838         |                 | 0.462          |
| 99-hole templet; lower surface of anode up..... | 99.266           | 80.906         |                 | .462           |
| Hole <i>X</i> <sup>a</sup> .....                | 99.208           | 80.763         |                 | .467           |
| Hole <i>Y</i> <sup>a</sup> .....                | 99.244           | 81.052         |                 | .462           |
| Average, 99-hole templets.....                  | 99.2675          | 80.872         |                 | .4620          |
| Average, holes <i>X</i> and <i>Y</i> .....      | 99.2260          | 80.908         |                 | .4645          |

<sup>a</sup> For location of holes see figure 26, which shows a similar templet.

The results presented in the table are a striking illustration of how a correct sample may be obtained by confining the drilling to a restricted area of a plate or slab. However, such drilling is not advocated as a working method, but the data are presented as a proof of how reliable a drilled sample must become when obtained according to a systematically laid out templet covering the whole, one-half, or one-fourth of the surface of the plate or slab sampled.

#### COMPARATIVE RESULTS OF SHOT SAMPLING AND OF DRILL SAMPLING.

Numerous demonstrations have been made showing the agreement between shot sampling and drill sampling when both are carried out in a technically correct manner. The figures in Table 16 are a further illustration of such work done on a large commercial scale with material and templet as shown in figure 26. The copper and silver results show close agreement; the onesidedness of the gold assays can not be attributed to the samples.

TABLE 16.—Monthly average results of assays of Western shot and Eastern drilled samples of refined converted copper.

| Month No. | Copper.                  |                          | Difference.            |                         | Silver, per ton.       |                         | Difference.           |                      | Gold, per ton.        |                         | Difference.           |                      |
|-----------|--------------------------|--------------------------|------------------------|-------------------------|------------------------|-------------------------|-----------------------|----------------------|-----------------------|-------------------------|-----------------------|----------------------|
|           | Western shot sample.     | Eastern drilled sample.  | Over.                  | Under.                  | Western shot sample.   | Eastern drilled sample. | Over.                 | Under.               | Western shot sample.  | Eastern drilled sample. | Over.                 | Under.               |
| 1.....    | <i>P. ct.</i><br>99.3499 | <i>P. ct.</i><br>99.2922 | <i>P. ct.</i><br>..... | <i>P. ct.</i><br>0.0577 | <i>Ozs.</i><br>88.6736 | <i>Ozs.</i><br>88.9444  | <i>Ozs.</i><br>0.2708 | <i>Ozs.</i><br>..... | <i>Ozs.</i><br>0.5147 | <i>Ozs.</i><br>0.5226   | <i>Ozs.</i><br>0.0079 | <i>Ozs.</i><br>..... |
| 2.....    | 99.3116                  | 99.3077                  | .....                  | .0039                   | 83.4784                | 83.5366                 | .0582                 | .....                | .4791                 | .4903                   | .0112                 | .....                |
| 3.....    | 99.2796                  | 99.2864                  | 0.0068                 | .....                   | 86.2927                | 86.2737                 | .....                 | 0.0190               | .4958                 | .5052                   | .0094                 | .....                |
| 4.....    | 99.2730                  | 99.2987                  | .0257                  | .....                   | 86.7758                | 86.8622                 | .0864                 | .....                | .4738                 | .4814                   | .0076                 | .....                |
| 5.....    | 99.2525                  | 99.2589                  | .0064                  | .....                   | 91.4387                | 91.4119                 | .....                 | .0268                | .6244                 | .6400                   | .0156                 | .....                |
| 6.....    | 99.2621                  | 99.2612                  | .....                  | .0009                   | 91.3735                | 91.4701                 | .0966                 | .....                | .5599                 | .5665                   | .0066                 | .....                |

## IRRATIONAL TEMPLET WILL NOT GIVE CORRECT SAMPLE.

One illustration of incorrect sampling will serve to show how easily an erroneous sample may be obtained. The material sampled was a low-grade argentiferous and auriferous copper in the form of cylinders, 14 inches in diameter by 7 inches thick. Previous drill sampling had been performed according to a templet with seven holes equally spaced along the diametral line. A new templet, which was rational according to the circular area of the cylinders, was laid out in seven zones containing, respectively, from the center outward, 1, 3, 5, 7, 9, 11, and 13 holes, or a total of 49 holes (see fig. 23, which shows a templet laid out in five zones). Forty-nine of the copper cylinders were drilled, making seven rounds for the old templet and one for the new. The following results were obtained from 10 assays of each kind of sample:

TABLE 17.—Average results of 10 assays of two kinds of samples of copper bullion cylinders.

| Templet used in taking sample. | Copper.                    | Silver, per ton.         | Gold, per ton.           |
|--------------------------------|----------------------------|--------------------------|--------------------------|
| Diametral .....                | <i>Per cent.</i><br>97.010 | <i>Ounces.</i><br>3.1745 | <i>Ounces.</i><br>0.0215 |
| Rational.....                  | 97.106                     | 2.8585                   | .0195                    |
| Difference.....                | + .096                     | — .3160                  | — .0020                  |
| Difference, per cent.....      |                            | 11.05                    | 10.26                    |

It is to be noted that the silver and gold assays of the sample taken according to the diametral templet were about 10 per cent higher than those of the sample taken by the rational templet, a difference larger than in any of the other examples of duplicate sampling, even of single pieces.

Having seen the comparative results of sampling by several methods on a large commercial scale, and also on a smaller scale in the way of special tests or experiments, and having, in general, found close concordance between the results obtained by the several methods, the source and extent of unavoidable errors may now be examined and the methods for determining the latter considered.

## ERRORS ARISING FROM DRILL SAMPLES FROM EDGE ZONE.

It has been pointed out that taking a sample through the edge zone of a bar or slab by drilling can not be theoretically correct and also that the sample so taken may be in excess but never deficient. Therefore, there are here two sources of results that are only approximate, containing errors that may tend in the same direction to vitiate the correct result, or that may tend in opposite directions, minimizing or balancing each other.



Figure 28 represents that section through  $CD$  of Plate II, which by  $\frac{1}{8}$ -inch cuts shows the variations in silver and gold content in the horizontal direction of the slab, from the edge to the center. In this figure is shown the calculated average silver content of every eight cuts that correspond to the parallelopipeds of the templet sections. These are designated  $P_1$  to  $P_7$ . There is also shown the calculated average silver content of every four cuts that correspond to the drill hole in each parallelopiped; these are designated  $D_1$  to  $D_7$ . It is here assumed that the actual drillings would have had the same content as the corresponding cuts. Yet it may be seen that all the results are approximations only; the silver in no paral-

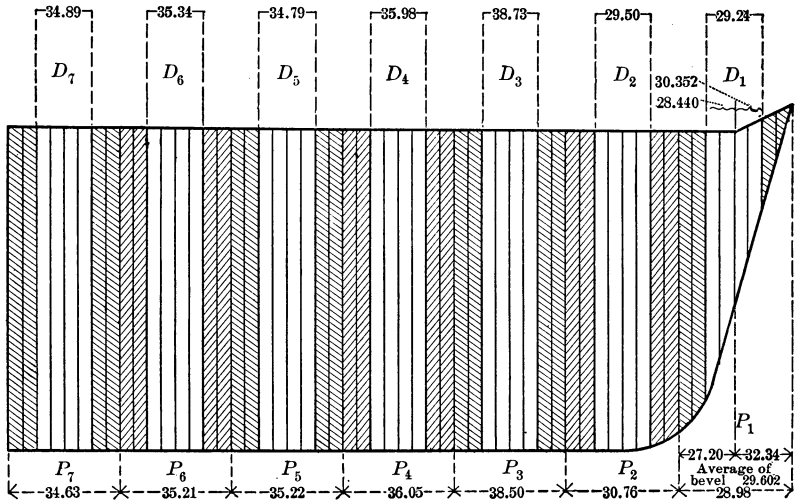

FIGURE 28.—Part of slab of converter copper bullion shown in Plate II, showing silver contents of parallelopipeds and corresponding drill holes. Relation of assays in bevel zone are:  $P=28.98$ ,  $D=29.24$ , excess in sample= $P_1-D_1=0.26$  ounce of silver per ton, or 0.89 per cent. Relation of average assays are: Average of all cuts, 34.530; average of all cuts in drill-hole locations, 34.336; deficiency of sample= $0.194$  grams, or 0.56 per cent.

lelopiped is equal to that in its corresponding drill hole. In practical sampling the difference between the average of  $P_1$  to  $P_7$  and the average of  $D_1$  to  $D_7$  would be considered a negligible quantity.

As shown in the figure the average silver assay of all parallelopipeds ( $P_1$  to  $P_7$ ) was 34.530 ounces of silver per ton, and of all cuts in drill-hole locations ( $D_1$  to  $D_7$ ), 34.336 ounces of silver per ton, the deficiency in the sample being 0.194 ounces of silver per ton, or 0.56 per cent.

The data are not sufficient to prove that the differences from  $P_2$  and  $D_2$  to  $P_7$  to  $D_7$  were haphazard, but it is more than probable that the order of these differences changed from piece to piece.

With  $P_1$  and  $D_1$  the case seems different, although here, too, the data are insufficient for a final conclusion. It may be noted that the highest silver in the individual cuts of  $P_1$  was in the right-hand or edge part, and that the highest silver of  $D_1$  was also in its right-hand half. This condition is likely to exist in many cases in which diffusion is centripetal, for in the edge (upper right-hand corner) the freezing is so rapid that it hinders diffusion, which does not reach its maximum rate until freezing reaches the left-hand side of  $P_1$  where the silver is lowest. From the geometry of the bevel indicated in Plate II, it may readily be deduced that the excess of sample was derived from the right-hand half of  $D_1$ , and that the assay of  $D_1$  would be higher than that of  $P_1$ . From this it plainly follows that as the silver assay of  $D_1$  was lower than the average assay of the bar or slab, the excessive weight of the sample would lower the average result for the slab, whereas the assay of  $D_1$ , being higher than the average assay of  $P_1$ , would raise the average result of the slab. In this special case the figures given below show how closely the two factors of the opposite sign balanced each other.

*Relation of assays in bevel zone.*

|                                    | Silver. |
|------------------------------------|---------|
| Assay of $P_1$ .....ounces per ton | 29.98   |
| Assay of $D_1$ .....do             | 29.24   |
|                                    |         |
| Excess in sample.....do            | .26     |
| Excess in sample.....per cent      | .89     |

*Relative weights of  $P_1$  and  $D_1$ .*

|  | Parts. |
|--|--------|
| Weight of $P_1$ .....                  | 55.60  |
| Weight of $D_1$ .....                  | 56.25  |
|  |        |
| Excess weight of sample, per cent..... | 1.16   |

OTHER EXAMPLES OF ERROR IN DRILL SAMPLES FROM BEVEL ZONE.

Plate IV shows the record of another test made to determine the extent of the weight and assay errors incident to sampling the bevel zone. The bevel was the same as that of the slab just discussed, its geometric relations being shown by a marginal drawing. All assay and weight data of this test are incorporated in the plate, but mention may be made of the fact that correct determinations were made of the silver and gold contents of the whole bevel zone, it being cut with a planer, corresponding to the bevel zone of the templet sections (bevel zone,  $\frac{7}{8}$  inch; templet-section zone, 1 inch); as also that content which would be given to it by the assay of the drill-hole zone alone, as is the case in actual sampling by drilling. On the plate the

bevel zone is designated *P* and the drill-hole zone *D*. The results of assays were as follows:

*Results of assays of samples of converter-copper slab, showing results of sampling bevel zone.*

|  | Silver. | Gold.  |
|--|---------|--------|
| Content in zone <i>P</i> _____ounces per ton__ | 30.781  | 6.3264 |
| Content in zone <i>D</i> _____do_____          | 31.252  | 6.3718 |
| Excess in zone <i>D</i> _____do_____           | .471    | .0454  |
| Excess in zone <i>D</i> _____per cent__        | 1.53    | .72    |

Counterbalancing these excessive assays of *D*, there is its own excessive weight, which was 1.16 per cent.

The contents of the slab, exclusive of the bevel zone, having been found, the contents of the total slab were computed by taking the correct contents of the bevel zone, the correct average of the whole slab being thus given; furthermore, the drill-hole zone content, as would be obtained in actual sampling by drilling, was taken as representing the average of the bevel zone, and thus the contents of the whole slab, such as the regular sampling by drilling would yield, were calculated. The results were as follows:

*Comparative average results of sampling converter-copper slab shown in Plate IV.*

|  | Silver. | Gold.  |
|--|---------|--------|
| Correct average of whole slab_ounces per ton__             | 33.841  | 6.6366 |
| Average by drill holes or<br>regular sampling _____do_____ | 33.892  | 6.6415 |
| Difference _____do_____                                    | .051    | .0049  |
| Excess in regular sample____per cent__                     | .150    | .074   |

That these relations will vary with the form of the bevel and the composition of the materials must be apparent.

Plate V shows figures similar to those shown in Plate IV, but the results would to some extent disprove any general conclusions based on those shown in Plate IV. Plate V shows the following essential values:

*Relative weights of *P* and *D* in bevel zone of converter-copper slab shown in Plate V.*

|                              | Per cent. |
|------------------------------|-----------|
| Weight of <i>P</i> _____     | 87.50     |
| Weight of <i>D</i> _____     | 100.00    |
| Excess weight of sample_____ | 12.50     |

The correct assay values for the bevel zone, or *P*, and the drill-hole zone, or *D*, show a relation opposite to that shown in the other examples; that is, *D* is lower than *P*. The values follow:

| BOTTOM DRILLING. |                          |                         |                       | BEVEL CUTS.  |                          |                         |                       | AVERAGE OF CAKE.  |                          |                         |                       |
|------------------|--------------------------|-------------------------|-----------------------|--|--------------------------|-------------------------|-----------------------|---|--------------------------|-------------------------|-----------------------|
| Zone No.         | Weight of sample, grams. | Silver, ounces per ton. | Gold, ounces per ton. | Cut.   | Weight of sample, grams. | Silver, ounces per ton. | Gold, ounces per ton. | Item.   | Weight of sample, grams. | Silver, ounces per ton. | Gold, ounces per ton. |
| 1.....           | 2,913                    | 35.259                  | 6.796                 | A <sub>1</sub> .....                               | 401                      | 39.011                  | 7.145                 | Average of cake exclusive of bevel—average of drill-hole zones.....                                   | 14070.2                  | 34.214                  | 6.674                 |
| 2.....           | 2,222                    | 33.397                  | 6.578                 | A <sub>2</sub> .....                               | 278                      | 39.556                  | 7.207                 | Average of cake inclusive of bevel with average assay of bevel, calculated theoretically correct..... | 15757.2                  | 33.941                  | 6.636                 |
| 3.....           | 1,775                    | 33.580                  | 6.572                 | A <sub>3</sub> .....                               | 413                      | 35.243                  | 6.951                 | Average of cake inclusive of bevel with drill-hole zone assay, actual working result.....             | 15757.2                  | 33.892                  | 6.6415                |
| 4.....           | 1,524                    | 33.097                  | 6.4964                | A <sub>4</sub> .....                               | 180                      | 37.105                  | 6.9614                | Excess in actual working result:  |                          |                         |                       |
| 5.....           | 1,571                    | 32.304                  | 6.4954                | Average.....                                       |                          |                         |                       | Ounces per ton.....   |                          | 0.051                   | 0.0049                |
| 6.....           | 1,204                    | 32.639                  | 6.5212                | B <sub>1</sub> .....                               | 2,990                    | 31.925                  | 6.4590                | Per cent.....   |                          | .015                    | .074                  |
| 7.....           | 970                      | 32.437                  | 6.5099                | B <sub>2</sub> .....                               | 1,316                    | 30.788                  | 6.340                 |   |                          |                         |                       |
| 8.....           | 766                      | 32.659                  | 6.5169                | B <sub>3</sub> .....                               | 2,204                    | 31.191                  | 6.3430                |   |                          |                         |                       |
| 9.....           | 326                      | 32.963                  | 6.5385                | B <sub>4</sub> .....                               | 1,511                    | 30.686                  | 6.2900                |   |                          |                         |                       |
| Average.....     | 33,901                   | 6.6417                  |                       | Drill-hole zone, D.....                            |                          | 31.252                  | 6.5718                |   |                          |                         |                       |
| TOP DRILLING.    |                          |                         |                       |  |                          |                         |                       |   |                          |                         |                       |
| 1.....           | 3,358                    | 35.637                  | 6.9656                | C <sub>1</sub> .....                               | 2,232                    | 28.564                  | 6.1052                |   |                          |                         |                       |
| 2.....           | 2,319                    | 33.226                  | 6.8388                | C <sub>2</sub> .....                               | 1,452                    | 29.528                  | 6.2470                |   |                          |                         |                       |
| 3.....           | 1,823                    | 34.082                  | 6.6696                | C <sub>3</sub> .....                               | 2,056                    | 29.516                  | 6.1822                |   |                          |                         |                       |
| 4.....           | 1,801                    | 32.654                  | 6.5337                | C <sub>4</sub> .....                               | 1,444                    | 28.575                  | 6.1102                |   |                          |                         |                       |
| 5.....           | 1,423                    | 32.556                  | 6.4194                | Average.....                                       |                          | 29.094                  | 6.1394                |   |                          |                         |                       |
| 6.....           | 1,239                    | 33.127                  | 6.5732                | A <sub>1</sub> B <sub>1</sub> C <sub>1</sub> ..... | 5,623                    | 31.096                  | 6.3674                |   |                          |                         |                       |
| 7.....           | 1,039                    | 33.635                  | 6.6254                | A <sub>2</sub> B <sub>2</sub> C <sub>2</sub> ..... | 3,548                    | 31.106                  | 6.3717                |   |                          |                         |                       |
| 8.....           | 831                      | 34.461                  | 6.7209                | A <sub>3</sub> B <sub>3</sub> C <sub>3</sub> ..... | 4,772                    | 30.730                  | 6.3035                |   |                          |                         |                       |
| 9.....           | 309                      | 35.431                  | 6.7875                | A <sub>4</sub> B <sub>4</sub> C <sub>4</sub> ..... | 3,165                    | 29.933                  | 6.2372                |   |                          |                         |                       |
| Average.....     | 34,433                   | 6.7051                  |                       | Total bevel, P.....                                |                          | 30.781                  | 6.3264                |   |                          |                         |                       |

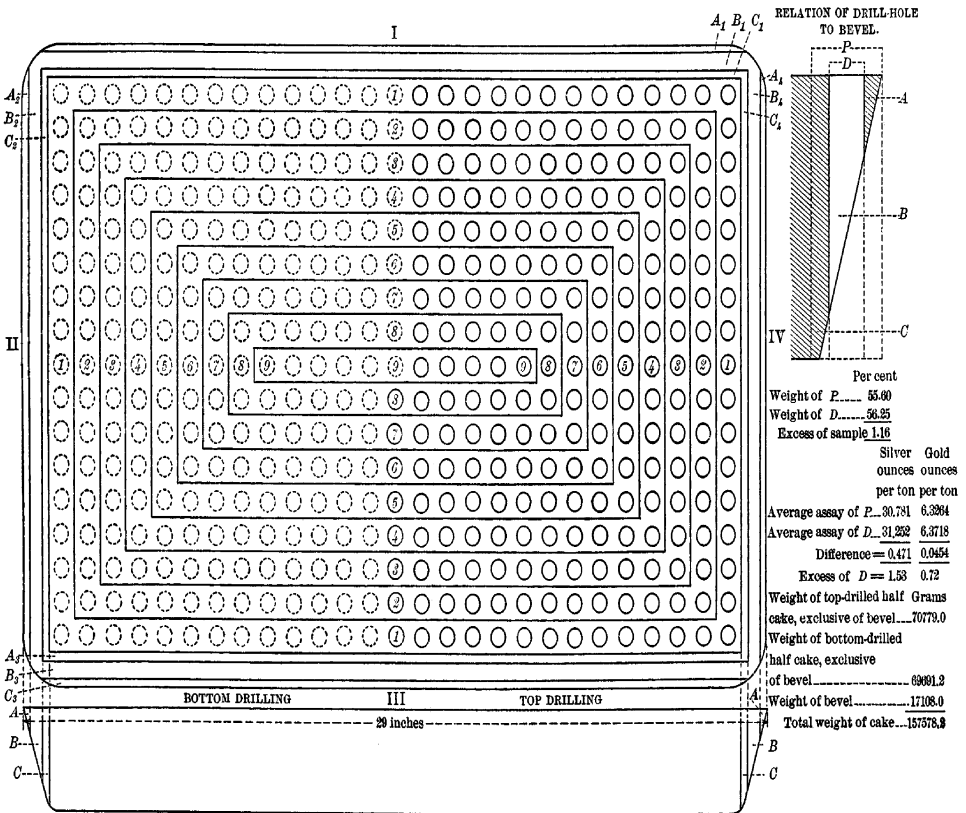

RESULTS OF SAMPLING CONVERTER COPPER SLAB, SHOWING EXTENT OF WEIGHT AND ASSAY ERRORS INCIDENT TO SAMPLING BEVEL ZONE BY CUTTING.

| BOTTOM DRILLING. |                          |                         |                       | BEVEL CUTS.                                    |                          |                         |                       | AVERAGE OF SLAB.  |                         |                       |
|------------------|--------------------------|-------------------------|-----------------------|--|--------------------------|-------------------------|-----------------------|---|-------------------------|-----------------------|
| Zone No.         | Weight of sample, grams. | Silver, ounces per ton. | Gold, ounces per ton. | Zone cut.                                      | Weight of sample, grams. | Silver, ounces per ton. | Gold, ounces per ton. | Item.   | Silver, ounces per ton. | Gold, ounces per ton. |
| 1                | 2,655                    | 189.60                  | 2.0173                | A <sub>1</sub>                                 | 699                      | 199.82                  | 2.0202                | Average assay of slab, with correct average of bevel  | 190.246                 | 2.0168                |
| 2                | 2,641                    | 191.70                  | 2.0268                | A <sub>2</sub>                                 | 589                      | 206.56                  | 2.1026                | Average assay of slab by drill holes  | 189.921                 | 2.0149                |
| 3                | 2,180                    | 181.36                  | 2.0208                | A <sub>3</sub>                                 | 879                      | 198.09                  | 2.0546                | Average assay of slab by drill holes, with correction of 12.5 per cent for excess of sample in bevel zone | 189.932                 | 2.0150                |
| 4                | 1,786                    | 189.24                  | 2.0188                | A <sub>4</sub>                                 | 735                      | 198.79                  | 2.0686                |   |                         |                       |
| 5                | 1,665                    | 188.41                  | 2.0363                | Average  | 200.403                  | 2.0746                  |                       |   |                         |                       |
| 6                | 1,412                    | 188.60                  | 2.0103                | B <sub>1</sub>                                 | 2,679                    | 193.33                  | 2.0246                |   |                         |                       |
| 7                | 1,164                    | 189.78                  | 2.0163                | B <sub>2</sub>                                 | 2,085                    | 199.31                  | 2.0075                |   |                         |                       |
| 8                | 829                      | 189.97                  | 2.0173                | B <sub>3</sub>                                 | 2,615                    | 191.12                  | 2.0156                |   |                         |                       |
| 9                | 345                      | 191.70                  | 2.0163                | B <sub>4</sub>                                 | 2,100                    | 188.80                  | 2.0116                |   |                         |                       |
| Average          | 190.655                  | 2.0178                  |                       | Drill hole, zone D                             | 190.841                  | 2.0155                  |                       |   |                         |                       |
| TOP DRILLING.    |                          |                         |                       |  |                          |                         |                       |   |                         |                       |
| 1                | 2,716                    | 189.28                  | 2.0046                | C <sub>1</sub>                                 | 2,340                    | 189.99                  | 2.0126                |   |                         |                       |
| 2                | 2,658                    | 191.69                  | 2.0192                | C <sub>2</sub>                                 | 1,461                    | 189.73                  | 2.0246                |   |                         |                       |
| 3                | 2,199                    | 191.82                  | 2.0212                | C <sub>3</sub>                                 | 2,747                    | 189.03                  | 2.0196                |   |                         |                       |
| 4                | 1,800                    | 189.19                  | 2.0102                | C <sub>4</sub>                                 | 1,492                    | 191.34                  | 2.0331                |   |                         |                       |
| 5                | 1,537                    | 188.27                  | 2.0092                | Average  | 189.865                  | 2.0173                  |                       |   |                         |                       |
| 6                | 1,270                    | 187.98                  | 1.9986                | Average of drill holes, zone 1                 | 189.453                  | 2.0109                  |                       |   |                         |                       |
| 7                | 1,048                    | 188.48                  | 2.0056                | Average of cuts and drill holes, zone 1        | 190.337                  | 2.0138                  |                       |   |                         |                       |
| 8                | 782                      | 189.65                  | 2.0142                | A <sub>1</sub> B <sub>1</sub> C <sub>1</sub>   | 5,718                    | 192.757                 | 2.0268                |   |                         |                       |
| 9                | 276                      | 188.43                  | 2.0039                | A <sub>2</sub> B <sub>2</sub> C <sub>2</sub>   | 4,085                    | 191.947                 | 2.0273                |   |                         |                       |
| Average          | 189.782                  | 2.0119                  |                       | A <sub>3</sub> B <sub>3</sub> C <sub>3</sub>   | 6,241                    | 191.183                 | 2.0229                |   |                         |                       |
|                  |                          |                         |                       | A <sub>4</sub> B <sub>4</sub> C <sub>4</sub>   | 4,327                    | 191.373                 | 2.0218                |   |                         |                       |
|                  |                          |                         |                       | Total bevel P                                  | 191.818                  | 2.0246                  |                       |   |                         |                       |
|                  |                          |                         |                       | Average of all cuts and drill holes in bevel P | 191.324                  | 2.0218                  |                       |   |                         |                       |

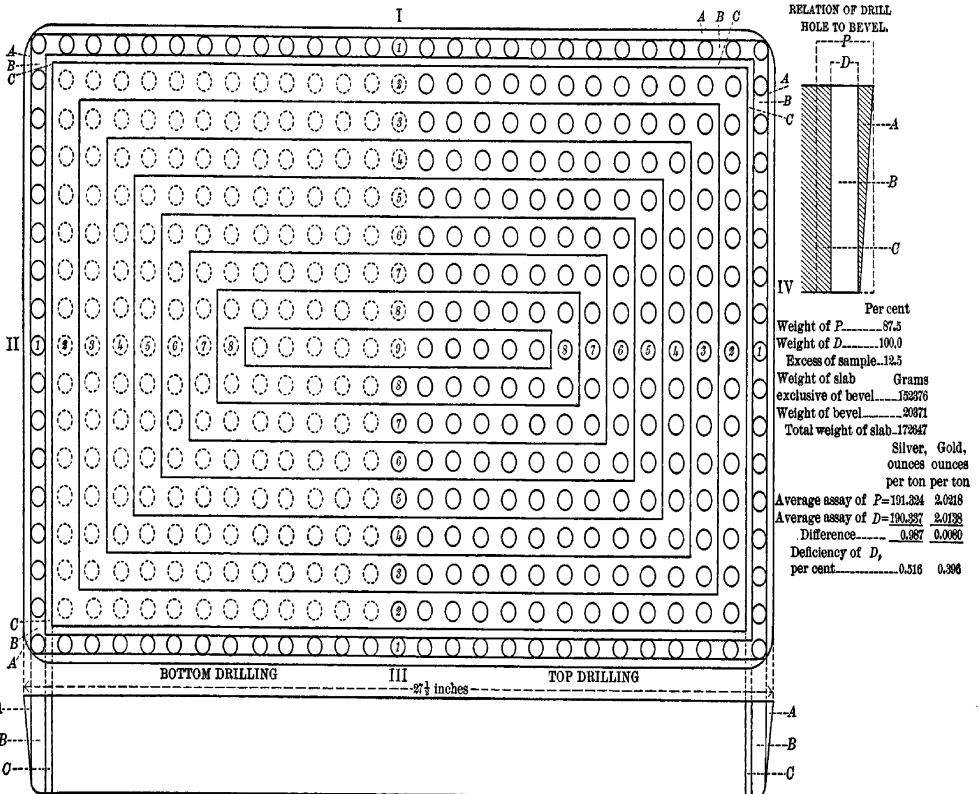

RESULTS OF SAMPLING CONVERTER COPPER SLAB, SHOWING EXTENT OF WEIGHT AND ASSAY ERRORS INCIDENT TO SAMPLING BEVEL ZONE BY DRILLING.

*Assay values for P and D in bevel zone of converter-copper slab shown in, Plate V.*

|  | Silver. | Gold.  |
|--|---------|--------|
| Content of zone P-----ounces per ton-- | 191.324 | 2.0218 |
| Content of zone D-----do-----          | 190.337 | 2.0138 |
| Difference-----do-----                 | .987    | .0080  |
| Deficiency in D-----per cent--         | .516    | .396   |

For the whole slab the following general results were obtained :

*General results of average assays of samples of converter-copper slab shown in Plate V.*

|  | Silver. | Gold.  |
|--|---------|--------|
| Average assay of slab with correct assay of bevel-----ounces per ton--   | 190.246 | 2.0168 |
| Average assay of slab by drill holes or regular sample-----ounces per ton--  | 189.921 | 2.0149 |
| Difference-----do-----   | .325    | .0019  |
| Deficiency in regular sample--per cent--   | .173    | .094   |
| Average assay of slab by drill holes, ounces per ton-----  | 189.921 | 2.0149 |
| Average assay of slab by drill holes with 12.5 per cent correction for excess of sample in bevel zone-----ounces per ton-- | 189.932 | 2.0150 |
| Difference -----do-----  | .011    | .0001  |
| Deficiency in regular sample--per cent--   | .0058   | .0060  |

The errors as found in the tests represented in Plates IV and V may be summed up as follows: In the tests represented in Plate IV the excesses of silver and gold in the sample of the bevel zone were 1.53 and 0.72 per cent of the correct content of the whole bevel. These figures affected the average assay of the whole slab by increasing the silver 0.15 per cent and the gold 0.074 per cent over the correct average. The influence of the excess of 1.16 per cent in the bevel sample due to its geometric form, as regards the average result for the whole slab, is negligible.

The deficiency in silver and the deficiency in gold in the sample of the bevel zone of the slab shown in Plate V were 0.516 and 0.396 per cent of the correct content of the whole bevel, causing deficiencies in the average content of the whole slab of 0.173 and 0.094 per cent below the correct average. A correction for the 12.5 per cent excess of sample of the bevel, due to the latter's geometric form, affected the silver and gold contents of the whole slab to the extent of 0.0058 and 0.0060 per cent. These last figures justify the conclusion that errors due to incorrect geometric forms of the bevel are negligible. Such errors are far overshadowed by the plus and minus errors due to drill sampling; the latter themselves must be regarded as relatively small.

## METHOD OF CORRECTING ERRORS IN SAMPLING BEVEL ZONE.

There is, however, a simple way to eliminate the error due to incorrect geometric relations in the bevel. In the slab shown in Plate V the excess of the drilled sample of the bevel was 12.5 per cent; this excess would have been exactly balanced if, when the slab was drilled, every eighth hole in the bevel zone had been omitted. For other amounts of excess of sample in the bevel the number of holes to be omitted in drilling may readily be calculated by a simple arithmetical operation.

## RESULTS OF SAMPLING DORÉ BAR TO DETERMINE GOLD CONTENT.

In a majority of the large copper refineries the precious metals originally contained in the copper bullion are also produced in the refined products, and one of the intermediate products, the doré bullion, is often sampled. In another section its behavior in liquid sampling has been described. Plate VI shows how the gold was distributed in a typical doré bar. It is evident that the gold concentrated to some degree in the parts that froze first.

As shown in the plate, the bar was sawed twice through its vertical plane, a thin slab, *X*, between the two cuts being thus produced. This slab was cut to destruction, every vertical  $\frac{1}{8}$  inch being separately taken as a sample; the assays showed the distribution of the gold in the vertical direction of the bar. Three saw cuts divided the bar into four horizontal slabs, which were drilled with a  $\frac{1}{4}$ -inch drill, according to a templet so designed that the holes would be continuous through the whole thickness of the bar. The samples of each drill hole in the individual slabs, as well as the sawings, were assayed for gold, the values being given in parts per 1,000. All average assays were calculated according to the weights of the samples. A résumé of these averages follows:

*Résumé of average assays of samples of doré bullion bar shown in Plate VI, parts per 1,000.*

| Slab.                     | Average gold content. |
|---------------------------|-----------------------|
| <i>A</i> (top) -----      | 6. 9015               |
| <i>B</i> -----            | 7. 0010               |
| <i>C</i> -----            | 6. 9967               |
| <i>D</i> (bottom) -----   | 6. 9561               |
| <i>X</i> (vertical) ----- | 6. 9892               |
| Whole bar -----           | 6. 9543               |

The highest and the lowest averages of the slabs differed only 3.50 and 2.66 per cent from the average of the bar. The highest and lowest individual assays were in the bottom cut of slab *X* and in one of the holes of slab *A*; they differed from the average of the whole

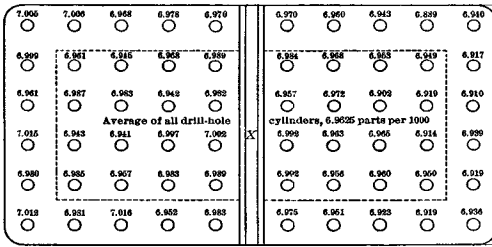

ASSAYS OF ENTIRE INDIVIDUAL DRILL-HOLE CYLINDERS

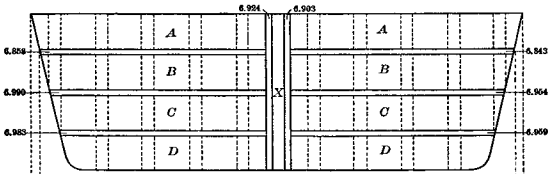
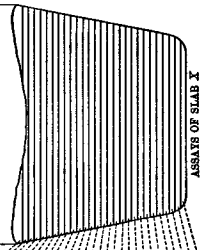

ASSAYS OF SAW CUTS

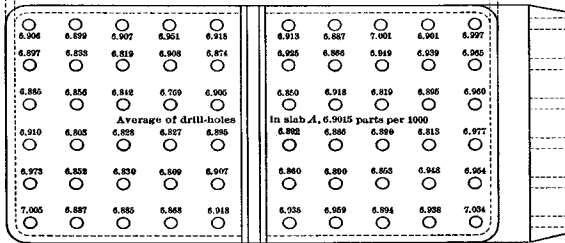

ASSAYS OF SLAB A

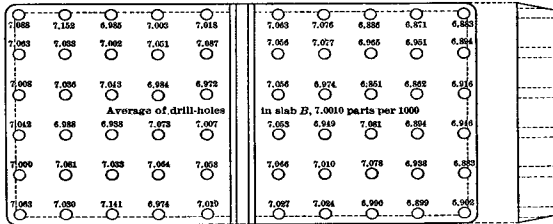

ASSAYS OF SLAB B

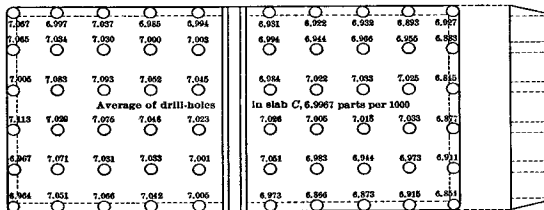

ASSAYS OF SLAB C

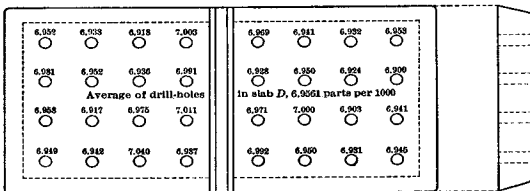

ASSAYS OF SLAB D

RESULTS OF ASSAYS OF DORÉ BULLION BAR, SHOWING DISTRIBUTION OF GOLD CONTENT, IN PARTS PER 1,000. ALL AVERAGE ASSAYS ARE CALCULATED ACCORDING TO WEIGHTS OF SAMPLES.



bar 3.50 per cent and 2.09 per cent. In copper bullion such differences are generally far greater, indicating that doré bullion offers smaller chances of error in sampling than does most copper bullion.

## RESULTS OF DUPLICATE SILVER ASSAYS OF CONVERTER-COPPER BULLION.

When tests for comparison between sampling methods are made, it is important that the experimental errors of assaying be reduced to a minimum. The average of not less than 10 silver and gold assays, made under identical conditions, should suffice to establish the average content of the samples. In Table 18 are given figures showing how duplicate silver assays will differ when the samples are taken from the homogeneous molten furnace charge or from heterogeneous slabs of copper bullion. The heterogeneity of the drilled samples seemingly had little effect on the differences between duplicate assays, although the average difference for these samples was slightly greater than for the shotted samples.

TABLE 18.—*Results of duplicate silver assays of converter-copper bullion.*

| Sample No. | Drilled samples.                     |                |                |                | Sample No.  | Shotted samples.                     |                |                |                |
|------------|--------------------------------------|----------------|----------------|----------------|-------------|--------------------------------------|----------------|----------------|----------------|
|            | Silver per ton according to assayer— |                | Difference.    |                |             | Silver per ton according to assayer— |                | Difference.    |                |
|            | A.                                   | B.             | Over.          | Under.         |             | A.                                   | B.             | Over.          | Under.         |
| 1.....     | <i>Ounces.</i>                       | <i>Ounces.</i> | <i>Ounces.</i> | <i>Ounces.</i> | 21.....     | <i>Ounces.</i>                       | <i>Ounces.</i> | <i>Ounces.</i> | <i>Ounces.</i> |
| 2.....     | 83.17                                | 82.87          | 0.30           | 0.85           | 22.....     | 79.00                                | 79.01          | 0.17           | 0.01           |
| 3.....     | 84.18                                | 83.76          | .42            |                | 23.....     | 80.09                                | 79.92          | 0.17           |                |
| 4.....     | 82.72                                | 82.64          | .08            |                | 24.....     | 81.84                                | 81.79          | .05            |                |
| 5.....     | 84.42                                | 84.46          |                | .04            | 25.....     | 84.05                                | 84.33          |                | .28            |
| 6.....     | 82.57                                | 82.53          | .04            |                | 26.....     | 86.93                                | 86.82          | .11            |                |
| 7.....     | 86.44                                | 86.80          |                | .36            | 27.....     | 88.68                                | 88.80          |                | .12            |
| 8.....     | 85.21                                | 85.39          |                | .18            | 28.....     | 83.28                                | 82.84          | .44            |                |
| 9.....     | 87.33                                | 87.31          | .02            |                | 29.....     | 82.62                                | 82.25          | .37            |                |
| 10.....    | 82.08                                | 81.96          | .12            |                | 30.....     | 80.90                                | 81.16          |                | .26            |
| 11.....    | 82.96                                | 83.06          |                | .10            | 31.....     | 82.83                                | 83.10          |                | .27            |
| 12.....    | 82.78                                | 82.75          | .03            |                | 32.....     | 74.07                                | 73.75          | .32            |                |
| 13.....    | 83.10                                | 83.11          |                | .01            | 33.....     | 79.22                                | 79.18          | .04            |                |
| 14.....    | 85.65                                | 85.69          |                | .04            | 34.....     | 79.34                                | 79.28          | .06            |                |
| 15.....    | 83.43                                | 83.55          |                | .12            | 35.....     | 82.12                                | 82.09          | .03            |                |
| 16.....    | 83.27                                | 83.43          |                | .16            | 36.....     | 79.10                                | 79.41          |                | .31            |
| 17.....    | 82.57                                | 82.81          |                | .24            | 37.....     | 80.33                                | 80.47          |                | .14            |
| 18.....    | 85.78                                | 86.03          |                | .25            | 38.....     | 79.28                                | 79.45          |                | .17            |
| 19.....    | 83.09                                | 83.46          |                | .37            | 39.....     | 80.42                                | 80.27          | .15            |                |
| 20.....    | 84.88                                | 85.10          |                | .22            | 40.....     | 74.15                                | 74.39          |                | .24            |
| Average..  | 83.9275                              | 84.0240        | .0965          |                | Average ... | 80.8040                              | 80.8060        | .002           |                |

## PART III. PROCEDURE AND EQUIPMENT USED IN SAMPLING.

### SAMPLING BY SHOTTING.

A foregoing section describes how shot sampling is best carried out. As previously stated, sampling by shotting is practiced at many of the large western copper smelteries, whereas at the lead smelteries a modification, involving button or gum drop sampling, is preferred.

Shotting is without doubt the cheapest method of obtaining a sample, and it should therefore be applied for all interdepartment sampling whenever feasible. It obviates the hauling of cast pieces from the furnaces to the sampling department and back and obviates also the machine work of drilling and grinding; in fact, it reduces the cost of sampling to a minimum. How unnecessary expense may be avoided is illustrated in the following concrete example:

For departmental purposes the argentiferous-auriferous copper from a furnace was sampled, four castings being hauled to the sampling room, there to have 10 holes drilled in each and the drillings ground and quartered to a 1-pound sample. Although the cost of such sampling was small, it could as well have been reduced practically to nothing by having a furnace man take a single shot sample in the proper way.

That a single shot sample from a molten furnace charge that has been treated in the regular way of refining will answer for all ordinary interdepartmental purposes may be recognized by considering the figures given in Table 19.

Twenty consecutive charges of copper from one furnace and three charges from another were each sampled as follows: One sample was taken from the middle of the first third of the charge, one from the middle of the whole charge, and one from the middle of the last third of the charge. They were designated as first, second, and third samples; the first being from the upper third, the third from the lower third of the charge. In each sample the silver was determined as being the element especially subject to diffusion.

TABLE 19.—*Results of silver assays of copper bullion from 23 furnace charges.*

[Results in ounces per ton.]

| Furnace charge No. | First sample. | Second sample. | Third sample. | Average. | Furnace charge No.          | First sample. | Second sample. | Third sample. | Average. |
|--------------------|---------------|----------------|---------------|----------|-----------------------------|---------------|----------------|---------------|----------|
| 1.....             | 106.70        | 106.50         | 104.30        | 105.83   | 14.....                     | 106.80        | 106.90         | 107.40        | 107.03   |
| 2.....             | 110.40        | 110.20         | 109.10        | 109.90   | 15.....                     | 101.20        | 101.40         | 101.40        | 101.33   |
| 3.....             | 107.80        | 107.90         | 107.90        | 107.87   | Average..                   | 107.54        | 107.28         | 107.10        | 107.30   |
| 4.....             | 108.10        | 108.10         | 108.20        | 108.13   | 16.....                     | 110.50        | 109.70         | 109.80        | 110.00   |
| 5.....             | 106.90        | 106.00         | 105.70        | 106.20   | 17.....                     | 108.20        | 108.10         | 108.10        | 108.13   |
| Average..          | 107.98        | 107.74         | 107.04        | 107.59   | 18.....                     | 107.80        | 108.20         | 108.00        | 108.00   |
| 6.....             | 115.40        | 113.90         | 115.70        | 115.00   | 19.....                     | 105.80        | 106.80         | 106.50        | 106.37   |
| 7.....             | 109.10        | 108.90         | 108.10        | 108.70   | 20.....                     | 103.40        | 101.80         | 101.40        | 102.20   |
| 8.....             | 107.90        | 108.60         | 106.60        | 107.70   | Average..                   | 107.14        | 106.92         | 106.76        | 106.94   |
| 9.....             | 108.50        | 108.80         | 108.10        | 108.47   | Total average, 1 to 20..... | 107.99        | 107.805        | 107.44        | 107.745  |
| 10.....            | 105.60        | 106.20         | 105.80        | 105.87   | 21.....                     | 163.60        | 163.20         | 162.60        | 163.13   |
| Average..          | 109.30        | 109.28         | 108.86        | 109.15   | 22.....                     | 363.90        | 363.30         | 362.50        | 363.23   |
| 11.....            | 113.00        | 111.80         | 110.10        | 111.63   | 23.....                     | 319.90        | 320.10         | 320.10        | 320.03   |
| 12.....            | 109.30        | 108.40         | 108.70        | 108.80   | Average..                   | 282.47        | 282.20         | 281.73        | 282.13   |
| 13.....            | 107.40        | 107.90         | 107.90        | 107.73   |                             |               |                |               |          |

Table 19 shows that each middle sample was fairly close to the average of the three samples, but it would be difficult to judge which of the three samples was the highest or lowest; in fact, that relation appears to have been irregular. When, however, the respective figures for the first, second, and third samples for every five charges are averaged, a regular order in these averages may be perceived, in every case the first sample being the highest and the third the lowest. Hence, the general conclusion may be drawn that the silver in a molten charge of copper slightly diffuses from the bottom toward the top, probably owing to the fact that after the poling or stirring has been finished and the molten mass has become quiescent, it will transmit more of its heat into the furnace bottom than into the heated atmosphere above, the upper part thus remaining hottest; consequently there is a diffusion in that direction.

Shotted copper is always slightly oxidized on the surface; therefore, shot sampling is not permissible if the highest accuracy in ascertaining the copper content is required, such as in electrolytic or lake copper. Here drilling is universally resorted to, for copper drillings without the slightest visible oxidation may be obtained.

### SAMPLING BY SAWING.

Although it has been learned that in certain cases sampling by sawing is the only way to arrive at a theoretically correct sample and that it is practiced in some works, the author has seen it at only one of the large copper plants in the East, where it is applied to thin plates (thickness about one-fourth inch) that are taken as samples from the anode furnaces. A common carpenter's circular saw, prop-

erly guarded, is used, and a sufficient number of cuts are sawed into the plate to produce a desired quantity of sample. The sawings need little grinding; they are liable to become considerably oxidized and thus nonrepresentative of the plate as regards its copper content, but are used for the silver and gold assays and for general analysis. This method undoubtedly entails some possibility of error; there is not the slightest reason to give it preference over shotting, which is less expensive and will yield a cleaner sample. The method appears eminently fit for sampling bars of precious and other non-oxidizable metals. It is, in fact, employed in a number of eastern establishments that deal in miscellaneous alloys, the latter generally having the shape of thick bars.

### SAMPLING BY DRILLING.

Commercially, drill sampling is the most important of the three methods of sampling under consideration, because it is applied to the vast quantities of copper materials that have been cast into marketable form and as such are shipped from place to place.

#### THE TEMPLET.

The basis for obtaining the nearest approximation to a correct drilled sample is the templet. Plate VII shows a collection of templets in actual use at the Raritan Copper Works. Each, in its dimensions, is equal to the surface of a bar or slab of a particular brand of copper bullion, although some bars are laid out in templet sections covering only a half or a fourth of their surfaces.

Slabs with beveled edges, coming from molds of exactly equal size, will have top surfaces of varying dimensions when the slabs are of varying thickness. This variation is not of sufficient consequence to necessitate sorting the slabs of equal thickness and applying separate templets. It is sufficient, in commercial practice, to ascertain the average dimensions of an arbitrary number of pieces and to give these dimensions to the templet.

In order to fix the location of any drill hole in the slab of bullion to be sampled the templet is placed on the surface of the slab and adjusted as nearly as possible to it. A piece of chalk is then rubbed over the proper hole in the templet, thus making a chalk mark on the slab. In the chalk mark a punch mark is then made, usually with the drill itself, and the chalk is removed by sweeping or with a small bellows.

#### ARRANGEMENT OF DRILLING ROOM.

The arrangement of the drill presses and their accessories varies to some degree in different works. Two typical arrangements are described below—the first, the arrangement at the Raritan Copper Works; the second, that of the United States Refining Co.

Plates VIII and IX illustrate the first method. In the immediate foreground in Plate VIII is shown a drill bench and a drill press, of which there are six in one series. On either side of these benches there is a narrow-gage railway track, similar to that on which the sample pieces, loaded on trucks, are brought into the drill room and taken out after having been drilled. The trucks are moved into proper position by means of a continuous cable propelled by an electric motor and a drum. The cable carries a clutch which is readily attached to or released from the trucks. The sample slabs, bars, etc., are transferred from the incoming trucks to the higher end of the benches and from the lower end of the benches to the outgoing trucks by means of air lifts and hooks. The air lifts and hooks are partly visible in the plates. Each bench consists essentially of two parallel planks on edge, each plank being covered with a piece of band iron, which serves as a slide, the friction being reduced by means of soap. Each bench has a slant of 4 inches in its length of 8 feet, so that the slabs, etc., may easily be slid from one end to the other. The middle part of the bench is so partitioned that a space is formed equal in cross section to the surface of the sample box placed below on slides. The bench has a steel-plate top extending from its higher end far enough to cover the sample-box partition. The sample box, when in place, is thus entirely encased and dustproof, which is essential. Beneath the drill the steel-plate top has a 2-inch hole through which the drillings may drop or be swept into the sample box.

In Plate VIII are seen some of the slabs on the bench and the drill man marking the location of a drill hole. Plate IX shows him in the act of drilling and an assistant bringing up another slab.

Another drill-room arrangement as developed at the United States Refining Co.'s plant is shown in Plates X to XII, differing essentially from that described above in the mechanical devices of the drill bench or table. The latter is best seen in its details in Plates X to XII and may be described by reference to the letters in Plate XI. Around the post, *a*, of the drill press there is a circular iron table, *b*, with a rail track, *c*, around the periphery. On this track are placed three small iron cars, *d*, which are equipped with a top plate, *e*, fixed to a pivot, *f*, which revolves with ease in either direction. On the plate there are two pieces of T rail, *g*, which serve as rests on which to drill the slabs. By means of the little car moving on the circular track and the revolving top any point marked for drilling on the surface of the slab is easily and quickly brought to the point perpendicularly beneath the drill.

There is a single-track railway for each drill press, of which there are three. The loaded truck comes in from one end of the room and is stopped before the drill press (see Pl. X), to be unloaded as fast

as the slabs can be drilled; it may then return the way it came or it may pass under the drill-press table to the other side, where the drilled slabs are reloaded (Pl. XII), and pass out through the other end of the room. The marking of the drill-hole locations (Pl. X) is done by the foreman; the placing of the slabs on the drill-press table (see Pls. X, XI) and from the latter back to the trucks is performed by laborers; the drill man attends solely to the drilling of the sample.

The sample box is not connected with the drill-press table; the drill man collects the drillings from each individual slab in a small pan placed beneath the slab at about the point where the drill emerges and afterwards deposits the drillings in a separate box.

It will be noted that the men about the drill presses wear goggles to protect their eyes. Attention may also be called to the rough character of the surface of many of the copper-bullion slabs, a characteristic of no other bullion. Because of the roughness there is likelihood of losing some of the drillings, and in order to reduce this loss to a minimum the precaution is taken at many copper refineries to place a metallic ring or cylinder, about 2 inches in diameter, around the drill, so as to confine the emerging drillings to the inclosed area. A heavy metallic cup with a hole in its bottom equal to the cross section of the drill is also employed; the drillings are supposed to collect in the cup. When a slab does not have a clean surface it is best to force drillings that collect thereon down through the drill hole into the sample box or pan.

#### LOCATING DRILL HOLES WITHOUT CHALKING.

As described above, the marking of the drill-hole locations is accomplished by applying templets of sheet iron or board and marking with chalk the proper points on the copper slabs. James K. Thomson has developed another method, which is practiced at the Nichols Copper Co.'s plant, and in which the use of chalk is entirely avoided and the extra service of a marker is never needed.

It may be assumed that a slab is to be drilled with the bottom surface up, the bevel zone being drilled with the top surface up. A templet is decided on, and the whole is laid out as shown in figure 29, A. The bottom surface has 16 rows of 9 holes each, or 144 holes, and the bevel has 54 holes. Supposing that there are five drill men and that each of four of them is to drill a zone of 36 holes on the bottom surface of the slab, and that the fifth is to drill the 54 holes of the bevel zone. Each drill man who is to drill the bottom surface is provided with a T-shaped sheet-iron guide (fig. 29, B) with 9 notches across the top and with three cross marks at the lower end of the bottom part of the T. The length of the bottom part of the

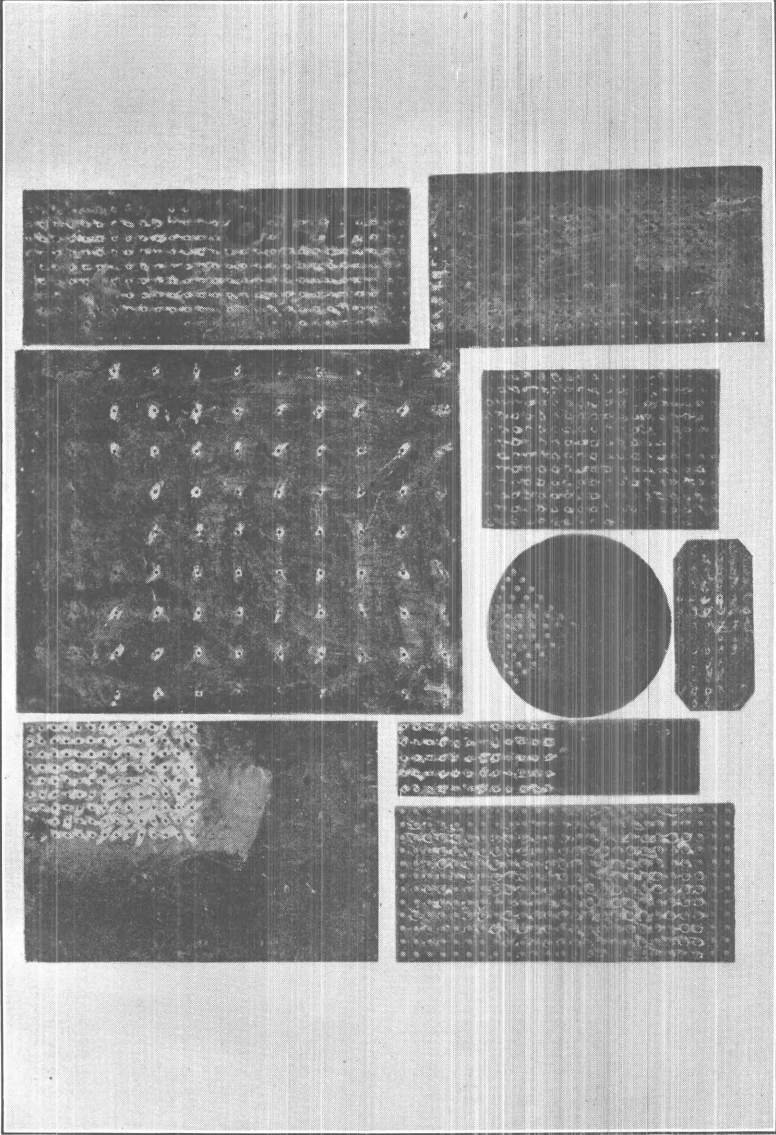

TEMPLATES FOR DRILLING VARIOUS COPPER SLABS.





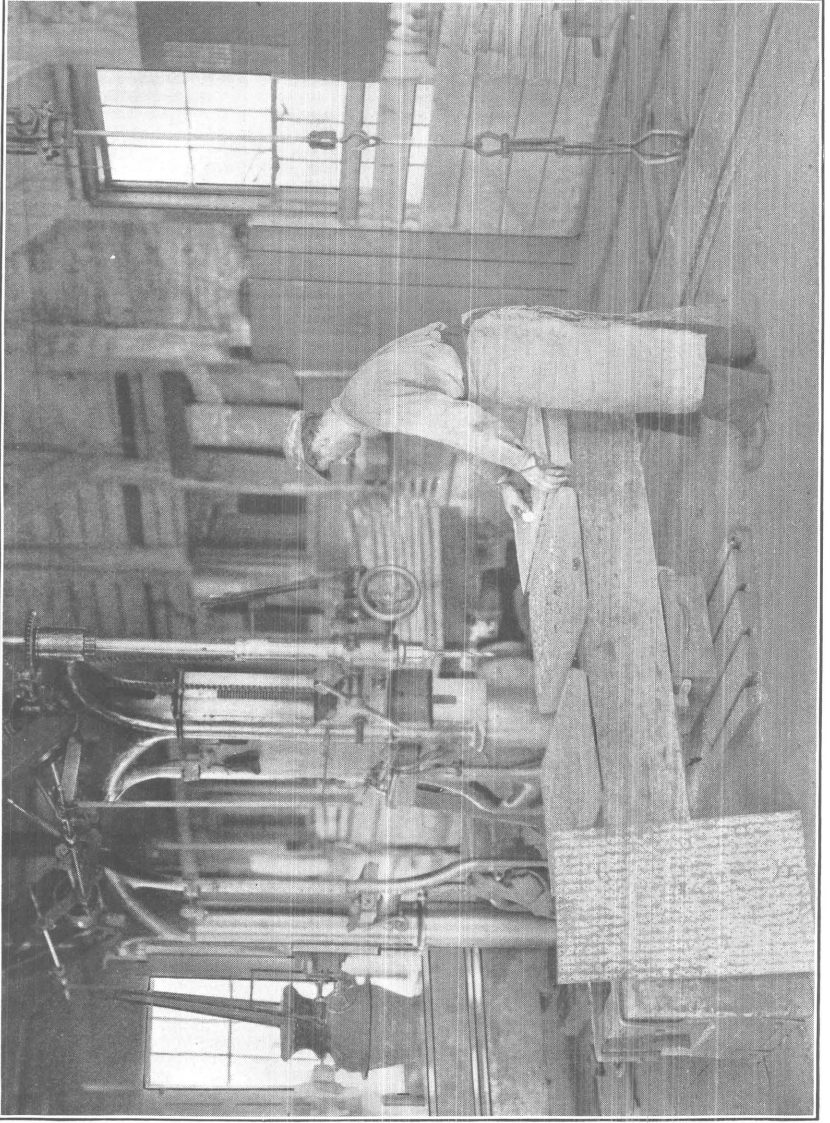

DRILLMAN LAYING OUT TEMPLATES. FIRST PLANT.

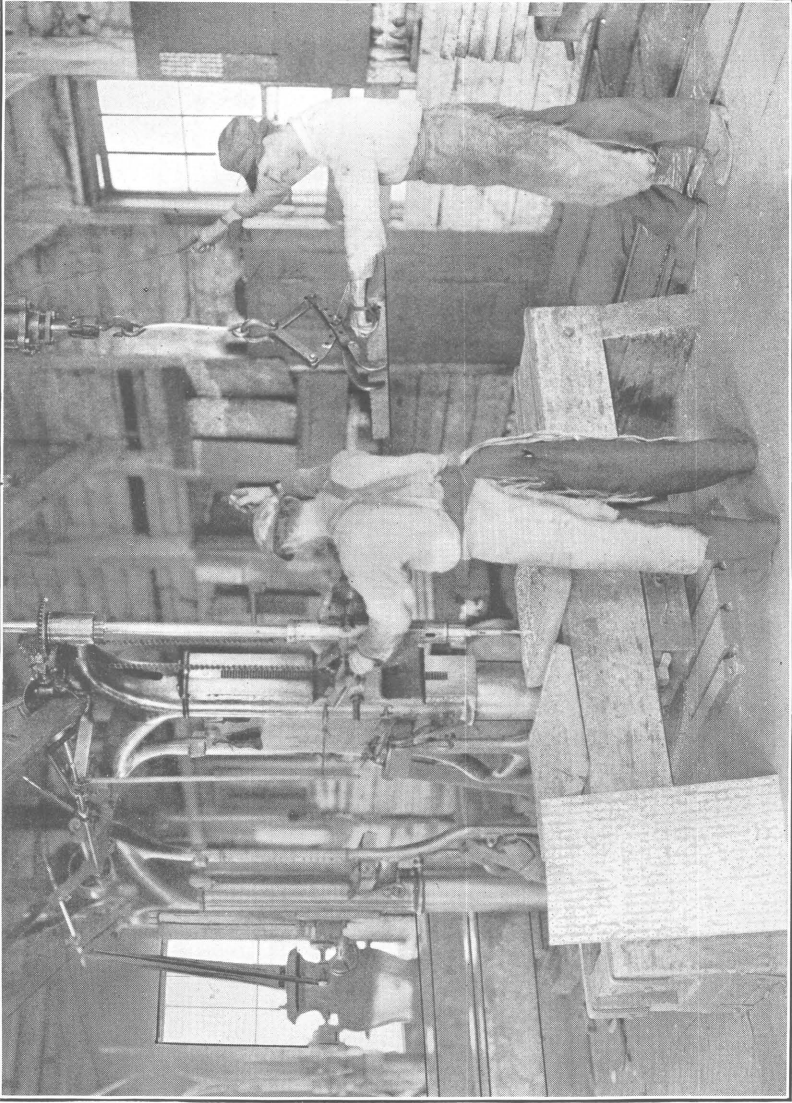

DRILLING THE HOLES. THE DRILLMAN'S ASSISTANT IS BRINGING UP ANOTHER SLAB. FIRST PLANT.

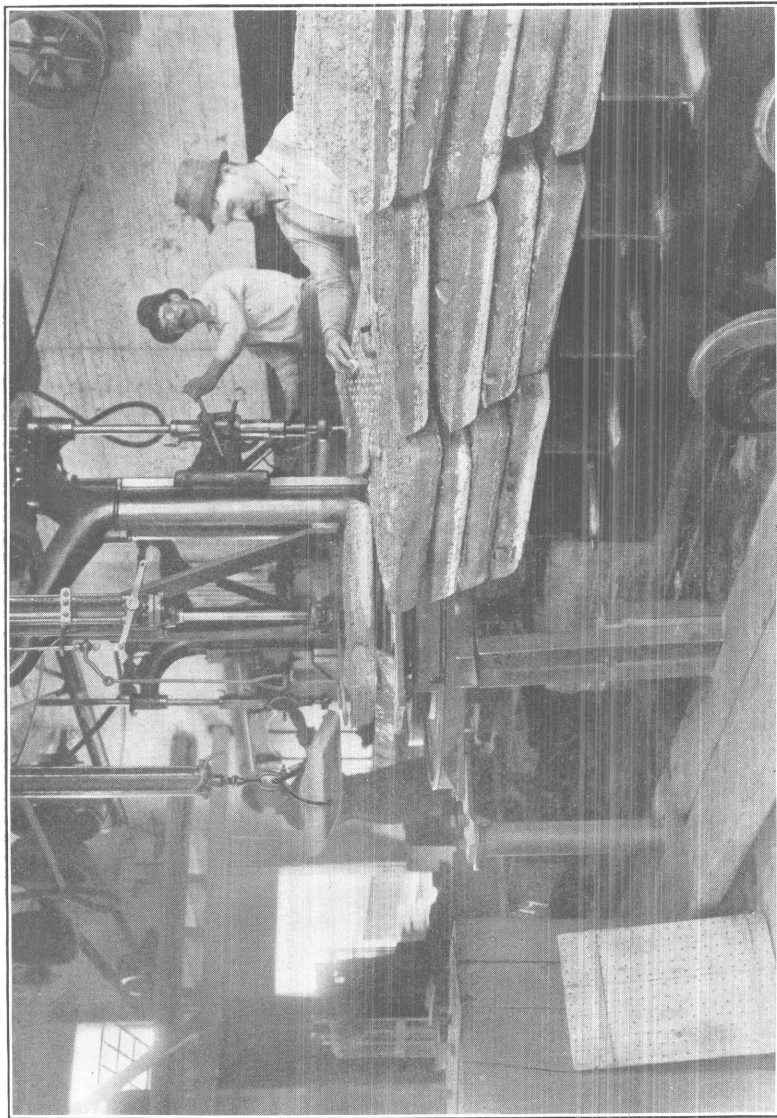

DRILL ROOM AT SECOND PLANT, SHOWING METHOD OF MARKING, DRILLING, AND HANDLING SLABS.

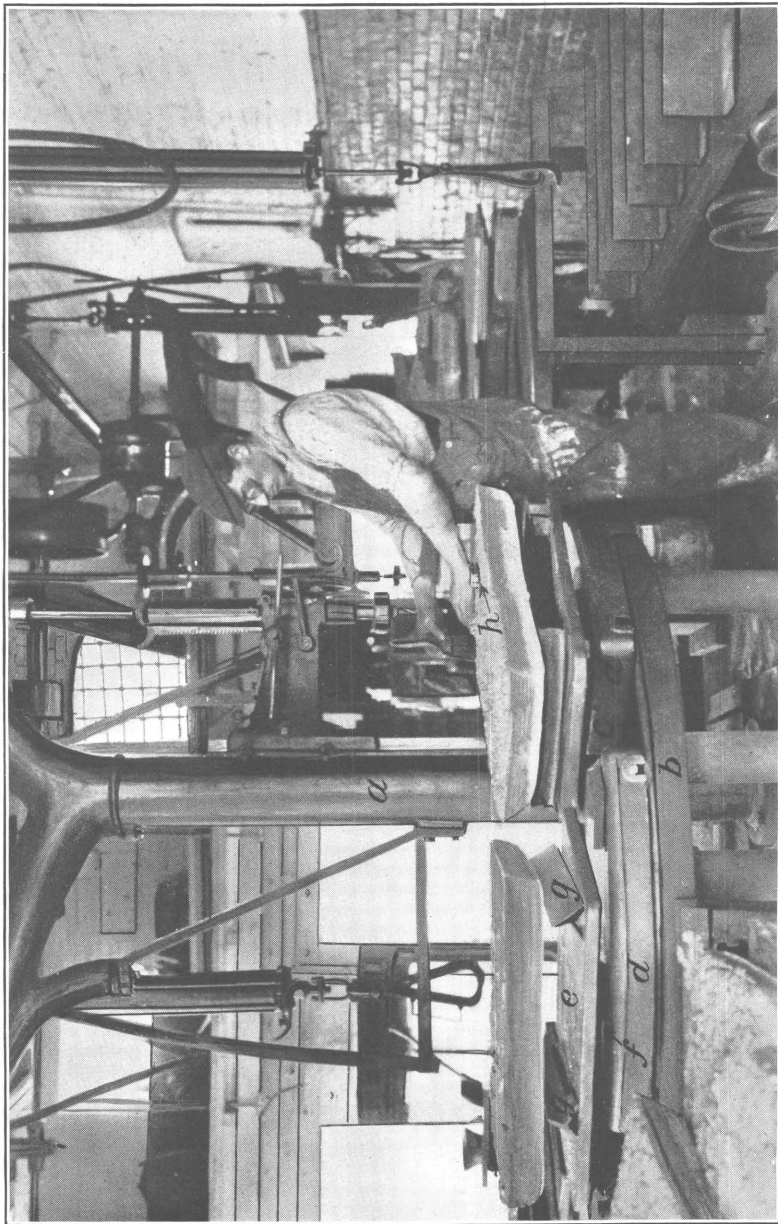

NEAR VIEW OF DRILL, SHOWING DETAILS OF DRILL AND CARRIAGE FOR SLABS. SECOND PLANT. DRILLMAN IS SWEEPING UP DRILLINGS. SMALL CYLINDER NEAR HIS LEFT HAND IS PLACED AROUND THE HOLE DURING DRILLING.

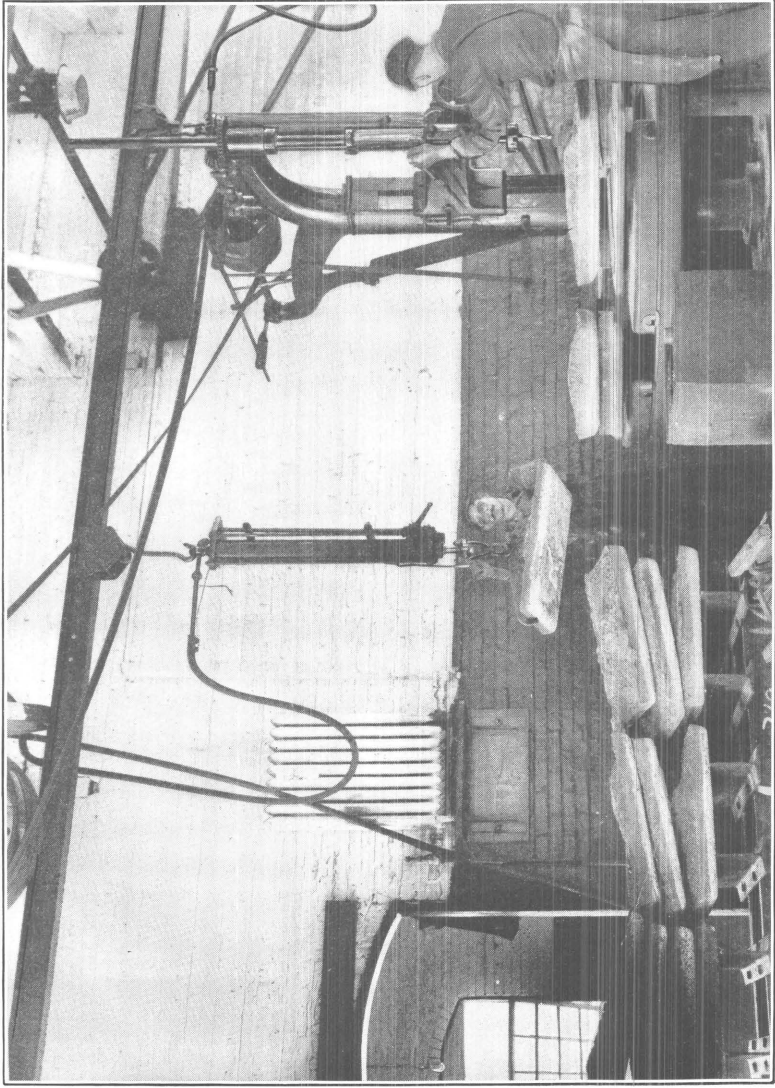

METHOD OF LOADING THE DRILLED SLABS, SECOND PLANT.



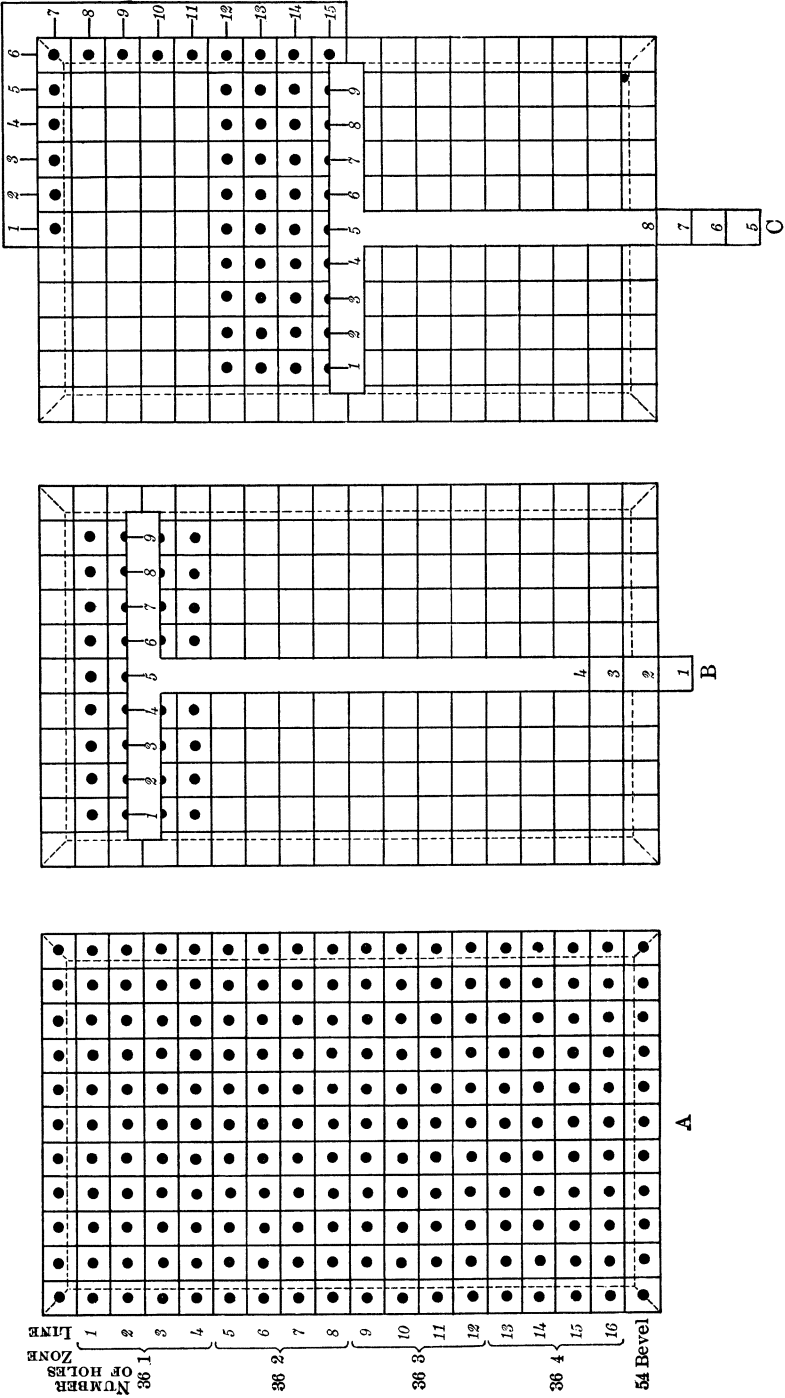

FIGURE 29.—Thomson method of marking drill-hole locations on bullion slabs.

It is regulated according to the zone to be drilled. Only two lengths are needed, because the zones in each half of the templet are identical. The drill man who is to drill the bevel zone is provided with a notched L-shaped guide like that shown in figure 29, C.

In connection with this system of marking and drilling, the trucks supply each man with the proper number of slabs, corresponding to the number of holes in the zone that he is to drill.

Although the method described eliminates the labor of marking the surface of the slabs and of removing the chalk therefrom and permits more rapid work by the drill men, the very absence of the chalk marks introduces a certain element of chance and places on the drill man a considerable degree of responsibility, because much is left to his judgment as to locating the holes. Slightly inaccurate placing of drill holes may be of little or no consequence in the inner part of a slab of large dimensions, but misplaced holes in the bevel zone may lead to appreciable errors.

#### DRILL PRESSES AND DRILLS.

Any make of drill press may serve for the purpose of drilling. It is essential, however, that the drill press have mechanism for hand feeding. Much greater speed of drilling will be accomplished by hand feeding than by automatic feeding. When material such as blister copper, in which cavities and sometimes slag are encountered, is being drilled, hand feeding will save much breakage of drills, as the drill man, by his sense of touch, may quickly detect an obstacle or a slipping of the drill.

We have already seen that at different works the usual machine-shop drill press table is supplanted by special devices.

Most of the drills (Plate XIII, A) used up to a recent date at the various copper refineries have been of  $\frac{1}{2}$ -inch diameter. None smaller was used, and at one plant only was a larger one, of  $\frac{3}{8}$ -inch diameter, employed. The drills used are all of the two-flute twist kind, with little difference in the length of twist or the depth of the relief of the cutting edge. The point, too, has the same angle in nearly all such drills. One exception was found at the works of the United States Copper Refinery, where a more pointed drill, with a notch in each cutting edge of the point, is used for drilling refined copper. The claim made for this drill is that it produces more continuous (less broken-up) drillings with less surface, the drillings being consequently less subject to oxidation. This drill is No. 5, Plate XIII, A. Four of the drills represented in the figure have a tapered shank, whereas the shank of one is perfectly straight. Drills with tapered shanks are readily retained in the socket of the drill press by friction, whereas a straight drill must be held by a set screw. The



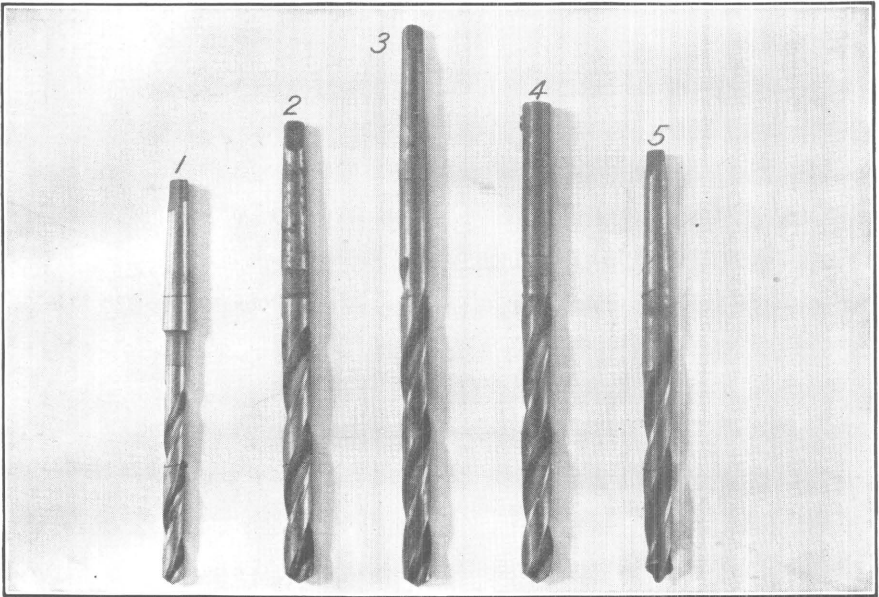

A. TWIST DRILLS.

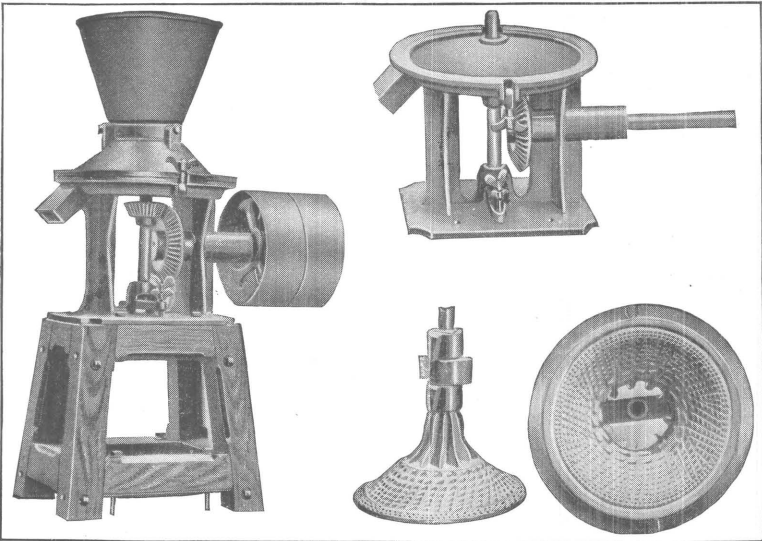

B. HANCE NO. 2 MILL.



danger from the set screw in the rapidly revolving shaft may be guarded against by a wooden ring, or cylinder, resting in a notch that covers it. Each of the drills shown in the figure has a slight taper from the point toward the shank.

The rotary speed at which the drills are driven seems to vary greatly. Several of the copper refineries employ a speed of 500 to 600 revolutions per minute. At the Nichols Copper Works, tests were made with speeds from 400 to 1,200 revolutions per minute, and it was found that 900 revolutions per minute gave the best results; this speed was no harder on the drills than the lower speeds and yielded considerably finer drillings. The highest speeds are hard on drills. A limit to the speed of the drills is set by the heating of the drillings, the temperature of which must not be high enough to cause oxidization. All lubricants should be barred as contaminating the sample.

With copper materials it is difficult to make conclusive tests to determine the life of drills. If there were homogeneity and uniform thickness of the material to be drilled, the quantity of drillings, during the lifetime of the drills would be a direct measure of the quality of the drills. However, these conditions are not to be found in practice. A thick bar exerts a greater strain on a drill than a thinner one; it may, therefore, be expected that a drill during its lifetime will yield more drillings from thin bars than a drill of equal quality from thicker bars.

For sharpening the drills, every drill room should be equipped with an emery wheel, with a holder attached, so that the drills are held at the proper angle to the wheel. Goggles and respirators should always be worn by the men when sharpening drills.

It has been reasoned that if a whole bar were drilled until it was entirely converted into drillings a theoretically correct sample of that bar would be the result; therefore, the greater the part of a bar drilled, or the larger the drill used, the closer the approximation will be to a correct sample. No objection can be made to this reasoning as regards thick heterogeneous bars. With thin plates or slabs of large horizontal dimensions it was found that, apart from the edge zone, a correct sample is obtained by drilling through the whole thickness of the slab, regardless of the size of the drill. With this principle in mind, the author has lately introduced the drill of  $\frac{3}{8}$ -inch diameter for drilling copper anodes and other materials, in order to reduce the bulk of drillings from large lots. The volumes and, with materials of equal density, the weights of the drillings from drill holes of different cross section are directly proportional to the cross-sectional areas. For the drills of the three diameters shown in Plate XIII, A, the following cross-sectional areas are found to be:  $\frac{3}{8}$ -inch

drill, 0.1105 square inch;  $\frac{1}{2}$ -inch drill, 0.1964 square inch;  $\frac{3}{16}$ -inch drill, 0.2485 square inch.

In round figures the weights of the drillings from the three drills stand in the relation of 11:20:25. The results of the operation of two drills of different diameters, as given below, may here be of interest:

*Results of drilling anodes with drills of different diameters.*

| Item.                            | $\frac{3}{16}$ -inch drill. | $\frac{1}{2}$ -inch drill. |
|----------------------------------|-----------------------------|----------------------------|
| Weight of anodes, pounds.....    | 11,745                      | 11,953                     |
| Number of anodes.....            | 21                          | 21                         |
| Number of holes drilled.....     | 42                          | 42                         |
| Weight of drillings, pounds..... | 2.375                       | 4.25                       |
| Time of drilling, minutes.....   | 65                          | 75                         |
| Time of grinding, minutes.....   | 20                          | 35                         |
| Total time, minutes.....         | 85                          | 110                        |

The figures giving the cost of operating the drills for the test showed a reduction of about 23 per cent in favor of the smaller drill. All the conditions were equal, except the weight of the anodes. The weight of the anodes drilled by the smaller drill was not quite 2 per cent less than the weight of the anodes drilled by the larger drill.

In the drilling of copper bullion the  $\frac{3}{16}$ -inch drill is probably the smallest that can be applied. Smaller drills would lack the strength and in many instances would yield an insufficient quantity of sample. For small bars or thin plates of precious or other metals much smaller drills could be employed.

#### GRINDING OF DRILLINGS.

Whenever the character of the bullion permits, the drillings should be ground to a considerable degree of fineness, assuring a homogeneity of the sample that is lacking in the drillings. The grinding of copper-bullion drillings is feasible if an appropriate grinding mill is used. There seems to be only one type of mill in use in the various copper refineries. It is the Hance No. 1 drug mill. Plate XIII, *B* shows a No. 2 mill. It is generally used as made by the manufacturers, but at the Raritan Copper Works it has been improved by making the grinding cones of chrome steel and by surrounding the cone shell with a water jacket. These changes prevent heating to such an extent that the mill can be kept in continual use, and it is claimed that the alterations have more than doubled the life of the cones. At the Baltimore Copper Works it was discovered that by causing the mill to revolve in a direction opposite to the one intended, by crossing the belt, the drillings could be ground

much finer than when the mill was operated in the regular way. The manufacturers explain that the mill was originally intended for dried roots, etc., and that the teeth are so constructed that they will draw these materials into the mill. Thus, when heavy metallic materials are being ground the construction of the teeth causes such materials to pass through the mill too quickly; the reverse motion retards the time of passage, causes the spaces to be more completely filled, and thereby produces finer grinding.

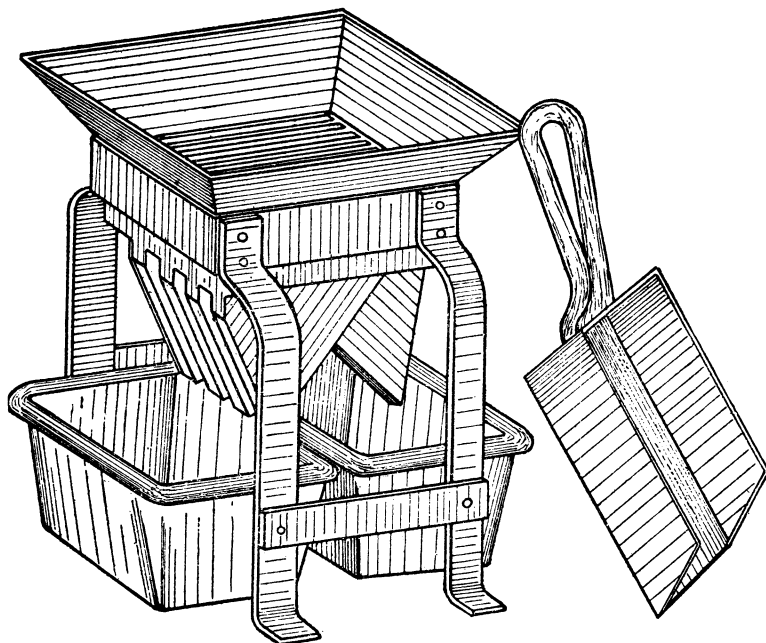

FIGURE 30.—Jones sampler.

#### REDUCTION OF DRILLINGS SAMPLE.

The quantity of drillings from any given lot of bullion depends on the size of the drill used and the number of holes drilled. As regards the usual copper-bullion drillings it is sufficient to grind them so that most of them will pass a screen of 10 meshes to the linear inch. They may then be reduced in quantity, by means of a Jones sampler (fig. 30) or a similar device, to the weight desired for the samples. At some of the works this quantity is run through the grinding mill until all passes a 20-mesh screen, and at others grinding until the material will pass a 16-mesh screen is deemed sufficient. The results presented in Table 18 indicate that the assays of heterogeneous drillings show only slightly greater variations than the assays of homogeneous shotted samples. It is thereby demonstrated that finer

grinding is unnecessary, the errors of assaying at this point becoming greater than those of sampling. The quantity of sample selected may vary greatly. For a works sample 0.5 pound should be sufficient; for a commercial sample as much as 5 pounds may be necessary, as the stipulation may be made that a 1-pound sample be put up for each of the following parties: The shipper, the refiner, the representative, and the umpire, and a reserve sample is usually specified. These details are generally the subject of contract agreement between the interested parties. Recorded data show that the time required for preparing a finished sample from drillings by grinding, cutting, and sifting is comparatively short, principally because with a large quantity of drillings the greater part is discarded after passing the 10-mesh screen. For example, 22 pounds of drillings was reduced to a 1-pound sample in 40 minutes, whereas a sample of the same weight was prepared from  $1\frac{1}{2}$  pounds of drillings in 16 minutes; a 16-mesh screen was used in preparing each sample.

RESULTS OF SCREENING A GIVEN LOT OF DRILLINGS.

Samples prepared by being ground and passed through a definite screen, 16 or 20 mesh, consist of particles of various sizes, the mesh of the screen being the measure for the maximum size only. Table 20 following conveys an idea of how such a sample is constituted, giving the sizes, weights, and assays of the several parts.

TABLE 20.—*Sizes, weights, and assays of parts of converter-copper sample.*

| Passed screen, mesh— | Held by screen, mesh— | Weight of particles. | Assay results.   |                 |                |
|----------------------|-----------------------|----------------------|------------------|-----------------|----------------|
|                      |                       |                      | Copper.          | Silver per ton. | Gold per ton.  |
|                      |                       | <i>Grams.</i>        | <i>Per cent.</i> | <i>Ounces.</i>  | <i>Ounces.</i> |
| 16                   | 20                    | 460                  | 99.350           | 36.56           | .2100          |
| 20                   | 30                    | 1,739                | 99.329           | 34.40           | .2067          |
| 30                   | 40                    | 828                  | 99.233           | 33.21           | .2017          |
| 40                   | 60                    | 405                  | 99.257           | 33.09           | .2000          |
| 60                   | 80                    | 139                  | 99.210           | 33.51           | .2000          |
| 80                   | 100                   | 86                   | 99.113           | 38.31           | .2450          |
| 100                  | .....                 | 190                  | 98.484           | 34.89           | .2083          |

An example of unusual heterogeneity as regards the current impurities and of homogeneity as regards silver may be seen in the results of analyses of a sample of arsenical copper, as presented in Table 21, following:

TABLE 21.—*Sizes, weights, and analyses of parts of arsenical-copper sample.*

| Passed screen, mesh— | Held by screen, mesh— | Weight of particles. | Analysis.               |                        |                        |                         |                         |                         |                         |
|----------------------|-----------------------|----------------------|-------------------------|------------------------|------------------------|-------------------------|-------------------------|-------------------------|-------------------------|
|                      |                       |                      | Cu.                     | As.                    | Sb.                    | Bi.                     | Fe.                     | Silver per ton.         | Gold per ton.           |
| 16                   | 40                    | <i>Grams.</i><br>257 | <i>P. ct.</i><br>98.254 | <i>P. ct.</i><br>0.610 | <i>P. ct.</i><br>0.014 | <i>P. ct.</i><br>0.0118 | <i>P. ct.</i><br>0.0386 | <i>Ounces.</i><br>50.07 | <i>Ounces.</i><br>0.042 |
| 40                   | -----                 | 118                  | 97.073                  | 1.345                  | .028                   | .0226                   | .0554                   | 50.14                   | .042                    |

The data contained in the last two tables, as also those in Table 5, clearly indicate that, in order to obtain correct analytical and assay results from a sample, we must insure the correct ratios of the sizes of the different parts of the ground sample in the charges for analysis or assay. In the laboratories of some works such ratios are believed to be obtained with sufficient degree of accuracy by reducing the sample to approximately the desired weight by a dividing device on the order of a Jones sampler and finishing to the proper weight by the use of a spatula. In the laboratories of other works the whole of the original sample is separated into coarse and fine parts, a separation for which the 40-mesh screen seems to have been generally adopted. The two sizes are weighed. In the charges for assay or analysis they are either combined in their proper ratio, or they may be separately assayed or analyzed and the average result calculated according to their weights. When a combination charge is used the procedure may be as follows: Let C=weight of coarse part of sample; F=weight of fine part; W=weight of charge for analysis or assay; W<sub>1</sub>=proper part of fine particles in W; W<sub>2</sub>=proper part of coarse particles in W; W<sub>1</sub>+W<sub>2</sub>=W. There need be calculated only W<sub>1</sub> or W<sub>2</sub>; both are unknown. By deducting the one, determined by calculation from W, the second is found. Hence it is necessary to calculate only the part containing the fine particles according to the formula,

$$W_1 = \frac{W}{\frac{C}{F} + 1}$$

**REMOVAL OF IRON OR STEEL FROM DRILLINGS SAMPLES.**

In the course of drilling and of grinding the drillings of any bullion, slight contamination of the sample by the metals of the machinery is practically inevitable. In the sampling of large quantities of refined copper bullion the author has found the contamination to be 0.0059 per cent of free iron, extracted by means of an electromagnet. At the American refinery, at Maurer, N. J., the figure 0.005 per cent was arrived at by determining the weight losses of

the machinery and the total weight of the bullion run through the machinery.

It would seem perfectly proper to eliminate such iron or steel from materials that have undergone a refining process. In other crude materials, however, there may be present far greater quantities of iron in combined form so as to be an integral part of the sample; hence the right to eliminate it can not be conceded. It has been argued that as the assay results are not, in general, strictly scientific, or theoretically correct, the samples must also be taken as commercial factors, prepared with all due care, but not with scientific refinement. However, a suggestion worthy of note has been made by Liddell.<sup>a</sup> By his method he would remove from the sample that which is extraneous contamination by iron or steel machinery and would leave in the sample such magnetic substances as are part of the bullion sampled. Liddell has found the contamination from the drills to be a negligible quantity. He believes that in the rough grinding all magnetic slag, which is supposed to be the essential part of ferruginous material belonging to the sample, becomes separated from the bullion proper and should be extracted by the magnet and reserved. Then the fine grinding, in which the main contamination from the grinding mill takes place, should proceed, and a second magnetic extraction should be made. The material separated by the second extraction should be discarded, whereas the material obtained by the first extraction should again be united with the sample.

One objection at least may be raised to Liddell's method. Some copper bullions contain iron, nickel, and arsenic in appreciable quantities which are likely to be combined as some magnetic compound. Undoubtedly this is originally in solution in the molten bullion and when the bullion freezes the compound crystallizes in close intermixture with the copper. Coarse grinding would not touch it, but, owing to its great brittleness, fine grinding would reduce it to particles smaller than the copper particles, and a magnet would remove much of it. Liddell's method, therefore, could not separate relevant and irrelevant matter in a sample of such bullion.

#### USE OF PUNCH IN SAMPLING.

In soft metal, such as lead, the drill does not work well, the flutes becoming clogged; but a hollow punch may readily be driven half-way, first from one side and then from the other, or entirely through a bar or slab by means of a heavy hammer or sledge. The resultant piece of metal or bullion from a bar is a core, several inches in length

---

<sup>a</sup> Liddell, D. M., Magnetic particles in copper-bullion sampling: Eng. and Min. Jour., vol. 90, 1910, p. 752.



and of about  $\frac{1}{8}$ -inch cross section. The cores can be cut into small pieces, but when there are many, it is necessary to melt and to cast them into a sample bar, from which the final sample is punched. In the lead smelteries, where this mode of sampling is still practiced, the punching is carried out by what is known as the "five-bar" system, or by a templet such as that shown in figure 21. A punch is illustrated in figure 31.

### PREPARING SAMPLE FOR DETERMINING SUBOXIDE IN COPPER.

#### SAMPLING BY FILING.

In copper refineries it is often necessary to determine the suboxide of copper, or cuprous oxide, in refined cast copper. The samples prepared by the methods heretofore described are too coarse for the purpose, and sampling by filing of the so-called test bars has been generally adopted. However, these bars have often been sampled by merely filing the surface around the four sides, the filings containing the thin surface film of the suboxide being discarded. That such sampling can not yield a correct sample may well be understood by reference to Heyn's results. Heyn<sup>a</sup> has shown that the homogeneous eutectic mixture of copper and its suboxide contains 3.84 per cent of the suboxide, whereas in properly refined copper there is only a fraction of 1 per cent of the suboxide.<sup>b</sup> It must consequently be expected that a strong concentration of the suboxide toward the

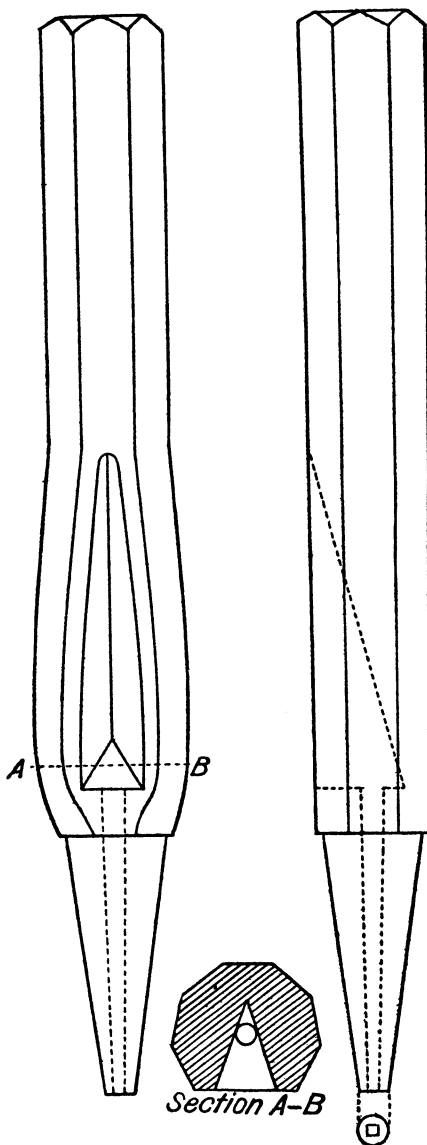

FIGURE 31.—Punch for sampling lead bullion or other soft alloys.

<sup>a</sup> See fig. 6, p. 15.

<sup>b</sup> Keller, Edward, The electrolysis and refining of copper: Min. Ind., vol. 7, 1899, p. 229.

freezing center of the bar takes place. Hence the best way to sample test bars is to saw them into two or more parts, clean the oxide film from the surfaces, and file evenly over the sawed cross-sectional plane or planes. This method of sampling is equivalent to a saw cut, and, as discussed on pages 41 to 43 and 51 to 52, such a method is necessary if a correct sample is to be obtained.

### RÉSUMÉ.

The possibilities of the simplest and cheapest ways of sampling have been indicated. Detailed figures as to the costs have not been presented, as costs vary with every lot of material sampled, depending on the number of sample pieces to be drilled, on their thickness, on their physical character, on the quantity of drillings to be ground, and the degree of fineness desired.

Numerous investigators have pointed out the heterogeneity of various bullions in the solid state, and up to a very recent date all of them have reached the conclusion that such bullions should be sampled from homogeneous molten charges. Raht strongly advocated this method for lead bullion. Many Western managers of copper smelters took the same stand; but when they themselves undertook to compare, with careful supervision, sampling by shotting of the molten furnace charges with drill sampling of the cast products they found both methods to be equally reliable. The statement may be made that shot sampling, when properly performed, is a good check against the sampling of solid materials, and that the sampling of solid materials, either by sawing or drilling, according to such theoretically correct templets as those shown in figures 18 and 23 and the more frequently employed templets laid out in square sections, is an equally good check against shot sampling. It is always important that the men in charge of the work be of the utmost integrity.

## PUBLICATIONS ON MINERAL TECHNOLOGY.

A limited supply of the following publications of the Bureau of Mines is temporarily available for free distribution. Requests for all publications can not be granted, and to insure equitable distribution applicants are requested to limit their selection to publications that may be of especial interest to them. Requests for publications should be addressed to the Director, Bureau of Mines:

BULLETIN 3. The coke industry of the United States as related to the foundry, by Richard Moldenke. 1910. 32 pp.

BULLETIN 16. The uses of peat for fuel and other purposes, by C. A. Davis. 1911. 214 pp., 1 pl., 1 fig.

BULLETIN 42. The sampling and examination of mine gases and natural gas, by G. A. Burrell and F. M. Seibert. 1913. 116 pp., 2 pls., 23 figs.

BULLETIN 45. Sand available for filling mine workings in the Northern Anthracite Coal Basin of Pennsylvania, by N. H. Darton. 1913. 33 pp., 8 pls., 5 figs.

BULLETIN 47. Notes on mineral wastes, by C. L. Parsons. 1912. 44 pp.

BULLETIN 53. Mining and treatment of feldspar and kaolin in the southern Appalachian region, by A. S. Watts. 1913. 170 pp., 16 pls., 12 figs.

BULLETIN 64. The titaniferous iron ores of the United States, their composition, and economic value, by J. T. Singewald, jr. 1913. 145 pp., 16 pls., 3 figs.

BULLETIN 71. Fuller's earth, by C. L. Parsons. 1913. 38 pp.

BULLETIN 81. The smelting of copper ores in the electric furnace, by D. A. Lyon and R. M. Keeney. 1915. 80 pp., 6 figs.

BULLETIN 84. Metallurgical smoke, by C. H. Fulton. 1915. 94 pp., 6 pls., 15 figs.

BULLETIN 85. Analyses of mine and car samples of coal collected in the fiscal years 1911 to 1913, by A. C. Fieldner, H. I. Smith, A. H. Fay, and Samuel Sanford. 1914. 444 pp., 2 figs.

BULLETIN 92. Feldspars of the New England and Northern Appalachian States, by A. S. Watts. 1915. 191 pp., 8 pls., 22 figs.

BULLETIN 100. Manufacture and uses of alloy steels, by H. D. Hibbard. 1915. 78 pp.

TECHNICAL PAPER 3. Specifications for the purchase of fuel oil for the Government, with directions for sampling oil and natural gas, by I. C. Allen. 1911. 13 pp.

TECHNICAL PAPER 8. Methods of analyzing coal and coke, by F. M. Stanton and A. C. Fieldner. 1913. 42 pp., 12 figs.

TECHNICAL PAPER 14. Apparatus for gas-analysis laboratories at coal mines, by G. A. Burrell and F. M. Seibert. 1913. 24 pp., 7 figs.

TECHNICAL PAPER 32. The cementing process of excluding water from oil wells, as practiced in California, by Ralph Arnold and V. R. Garñas. 1912. 12 pp., 1 fig.

TECHNICAL PAPER 38. Wastes in the production and utilization of natural gas, and means for their prevention, by Ralph Arnold and F. G. Clapp. 1913. 29 pp.

TECHNICAL PAPER 39. The inflammable gases in mine air, by G. A. Burrell and F. M. Seibert. 1913. 24 pp., 2 figs.

TECHNICAL PAPER 41. Mining and treatment of lead and zinc ores in the Joplin district, Missouri, a preliminary report by C. A. Wright. 1913. 43 pp., 5 figs.

TECHNICAL PAPER 43. The influence of inert gases on inflammable gaseous mixtures, by J. K. Clement. 1913. 24 pp., 1 pl., 8 figs.

TECHNICAL PAPER 50. Metallurgical coke, by A. W. Belden. 1913. 48 pp., 1 pl., 23 figs.

TECHNICAL PAPER 66. Mud-laden fluid applied to well drilling, by J. A. Pollard and A. G. Heggem. 1914. 21 pp., 12 figs.

TECHNICAL PAPER 68. Drilling wells in Oklahoma by the mud-laden fluid method, by A. G. Heggem and J. A. Pollard. 1914. 27 pp., 5 figs.

TECHNICAL PAPER 70. Methods of oil recovery in California, by Ralph Arnold and V. R. Garfias. 1914. 57 pp., 7 figs.

TECHNICAL PAPER 76. Notes on the sampling and analysis of coal, by A. C. Fieldner. 1914. 59 pp., 6 figs.

TECHNICAL PAPER 88. The radium-uranium ratio in carnotites, by S. C. Lind and C. F. Whittemore. 1915. 29 pp., 1 pl., 4 figs.

TECHNICAL PAPER 95. Mining and milling of lead and zinc ores in the Wisconsin district, Wisconsin, by C. A. Wright. 1915. 39 pp., 2 pls., 5 figs.

TECHNICAL PAPER 110. Monazite, thorium, and mesothorium, by K. L. Kithil. 1915. 32 pp., 1 fig.

TECHNICAL PAPER 111. Safety in stone quarrying, by Oliver Bowles. 1915. 48 pp., 5 pls., 4 figs.

# INDEX.

|   | Page.      | Page.   |            |
|---|------------|---|------------|
| <b>A.</b>   |            |   |            |
| Alexander, H. H., acknowledgment to cited -----                                   | 3<br>34    | Borings, metallic, sampling of ----- 35                       |            |
| "Alloys," definition of -----   | 19         | "Bullions," definition of ----- 19                            |            |
| high grade, sampling of, precautions in -----                                     | 56, 57     | <i>See also</i> Copper bullion; Doré bullion; Lead bullion.   |            |
| physical methods of determining, errors in -----                                  | 10, 11     | <b>C.</b>   |            |
| <i>See also</i> Binary alloys; Copper-silver alloys; Molten alloys; Solid alloys. |            | Castings, circular, sampling of, templet for -----            | 55, 56     |
| Aluminum, effect of, on molten steel -----  | 15, 16     | figure showing -----  | 56         |
| Antimony in copper bullion, proportion of -----                                   | 22, 24     | shape of, relation of, to diffusion -----                     | 39         |
| Arsenic in copper bullion, proportion of -----                                    | 22, 24, 93 | to method of sampling -----                                   | 39         |
| Arsenical copper sample, analyses of, results of -----                            | 93         | with bevel, sampling of -----                                 | 43, 44     |
| <b>B.</b>   |            |   |            |
| Bakhuis Roozeboom, H. W., on classification of binary-alloys solutions -----      | 6, 7       | <i>See also</i> Bars.   |            |
| Bars, bullion, characteristics of -----   | 64         | Chipping, sampling by means of, objections to -----           | 49         |
| dimensions of, effect on sampling -----   | 57, 58     | Clark, A. C., acknowledgment to -----                         | 3          |
| distribution of metals in, variations in -----                                    | 64         | Cobalt in copper bullion, proportion of -----                 | 24         |
| methods of sampling -----   | 40-47      | Conjugate alloys, definition of -----                         | 9          |
| sections of, figures showing -----  | 40, 43     | Copper anode, distribution of silver in, figure showing ----- | 72         |
| structure of, effect of, on sampling -----  | 47, 48     | drilling of, drill for -----                                  | 89         |
| variations in -----   | 50         | results of -----  | 90         |
| Bevel, effect of, on sampling -----   | 43-47      | refined, assays of, results of -----                          | 73, 74     |
| figure showing -----  | 44         | sampling of, method of -----                                  | 71, 73, 74 |
| relation of drill hole sample to, figure showing -----                            | 46         | results of -----  | 71, 73, 74 |
| Bevel zone, assays in, figure showing -----                                       | 76         | Converter copper slabs, assays of -----                       | 66,        |
| relation of -----   | 77         | figure showing -----  | 78, 79     |
| sampling of, errors in -----  | 75-79      | results of -----  | 81         |
| correction of -----   | 80         | distribution of metals in -----                               | 65         |
| figures showing -----   | 78         | figure showing -----  | 25, 67     |
| results of -----  | 78         | drilling of, factors in -----                                 | 59, 60     |
| Binary-alloy solutions, characteristics of -----                                  | 6-8, 20    | results of, figure showing -----                              | 64         |
| classes of -----  | 6-9        | gas-finished, analyses of -----                               | 22, 24     |
| freezing points of, figures showing -----   | 6-8        | refined, assays of, results of -----                          | 71, 74     |
| Bismuth in copper bullion, proportion of -----                                    | 22, 24, 93 | sampling of, difficulties in -----                            | 59         |
| Black copper, analysis of -----   | 24         | results of, figure showing -----                              | 78         |
| difficulties in sampling -----  | 59         | surface enrichment of, cause of -----                         | 59         |
| distribution of gold and silver in, figure showing -----                          | 26         | <i>See also</i> Bars; Plates; Slabs.                          |            |
|   |            | Copper bullion, analyses of -----                             | 24         |
|   |            | distribution of metals in, determination of -----             | 22         |
|   |            | discussion of -----   | 23, 24     |
|   |            | extraneous matter in, effect of -----                         | 35         |
|   |            | moisture in, determination of -----                           | 38         |
|   |            | "pickling" of -----   | 35         |
|   |            | refined, characteristics of -----                             | 69         |
|   |            | distribution of silver in, figure showing -----               | 70         |
|   |            | sampling of, difficulties in -----                            | 59         |
|   |            | method of -----   | 32         |
|   |            | results of -----  | 28, 69-71  |
|   |            | figure showing -----  | 70         |

|  | Page.                      |   | Page.                          |
|--|----------------------------|---|--------------------------------|
| Copper-copper suboxide alloys, freezing point of, figure showing     | 15                         | Drilling, as method of sampling, accuracy of      | 42                             |
| homogeneity of   | 15                         | discussion of                                     | 41, 49                         |
| Copper in converter copper, proportion of                            | 66, 68, 69, 74             | relative merits of                                | 96                             |
| output of, in United States  | 58                         | results of  | 74                             |
| <i>See also</i> Black copper; Converter copper.                      |                            | figure showing                                    | 70                             |
| Copper oxide, effect of, on copper bullion                           | 22, 24                     | bottom, results of                                | 78                             |
| Copper-silver alloys, experiments with, cube used in, figure showing | 12                         | difficulties in                                   | 59, 60                         |
| freezing of  | 11, 14                     | effect of, on weight of samples                   | 61, 62                         |
| heterogeneity in   | 11                         | factors in  | 59, 60                         |
| homogeneity in   | 21                         | sampling of circular castings by                  | 55, 56                         |
| low-grade, sampling of, results of                                   | 12, 13                     | templet for sampling by, figure showing           | 52, 56                         |
| Copper sulphide, effect of, on converter copper                      | 23, 24                     | <i>See also</i> Templet.                          |                                |
| Cuprous oxide in copper, determination of                            | 95, 96                     | top, results of                                   | 60, 78                         |
| Cut sample of copper bullion, assay of, results of                   | 63, 65                     | figure showing                                    | 64                             |
| figure showing   | 64                         | view of   | 86                             |
|  |                            | Drills, cost of operating, factor affecting       | 90                             |
| D.   |                            | details of, view of                               | 86                             |
| Deacon, R. W., acknowledgment to                                     | 3                          | life of   | 89                             |
| Derby, W. G., acknowledgment to                                      | 3                          | sharpening of                                     | 89                             |
| Diffusion, definition of   | 16                         | speed of driving                                  | 89                             |
| in alloys, direction of, control of                                  | 27                         | types of, description of                          | 88, 89                         |
| discussion of  | 62                         | view of   | 88                             |
| varying, theory regarding  | 27                         | varying diameters of                              | 89, 90                         |
| relation of shape of casting to                                      | 39                         |   |                                |
| Doré bullion, samples of, assays of                                  | 32                         | E.  |                                |
| results of, figure showing   | 80                         | Eastern samples. <i>See</i> Refinery samples.     |                                |
| sampling of, results of  | 80                         | England, sampling method used in                  | 51                             |
| Drill holes in circular casting, number of, factors governing        | 56                         |   |                                |
| marking of   | 86-88                      | F.  |                                |
| method of, figure showing  | 87                         | Freezing points of alloys, discussion of          | 6-9, 11, 14                    |
| Drill presses, hand feeding of, need of                              | 88                         | figures showing                                   | 6-8                            |
| Drill room, apparatus in, arrangement of                             | 85                         | variations in, effect on heterogeneity            | 10                             |
| description of   | 85, 86                     | Friedrich, K., cited                              | 14                             |
| view showing   | 86                         |   |                                |
| Drill sample, assays of, results of                                  | 53, 63, 65, 66, 68, 69, 81 | G.  |                                |
| effect of mold wash on   | 36, 37                     | Goggles, wearing of, in drill room                | 86, 89                         |
| from bevel zone, errors in   | 75-79                      | Gold, in copper bullion, distribution of          | 22, 62, 63, 65, 68, 69, 74, 78 |
| grinding of  | 90, 91                     | figure showing                                    | 25, 26, 62, 64                 |
| mill for grinding, view of   | 88                         | proportion of                                     | 24, 66                         |
| preparation of, time required for                                    | 92                         | in doré bullion, distribution of                  | 32,                            |
| reduction of   | 91                         | figure showing                                    | 33, 80                         |
| relation of, to bevel, figure showing                                | 46                         | output of, in United States                       | 58                             |
| removal of iron from   | 93, 94                     | Gouging, sampling by means of, objections to      | 49                             |
| results of screening   | 92                         |   |                                |
| size of  | 92                         | H.  |                                |
|  |                            | Hance mill for grinding drillings, description of | 90, 91                         |
|  |                            | view of   | 88                             |
|  |                            | Heterogeneity of binary alloys                    | 11, 12                         |
|  |                            | factors governing                                 | 6, 7, 9, 10                    |
|  |                            | Heterogeneous materials, sampling of              | 5                              |
|  |                            | Heycock, C. T., cited                             | 14                             |
|  |                            | on homogeneity of tin-copper alloy                | 14, 15                         |

|   | Page.     |
|---|-----------|
| Heyn, E., on copper-copper suboxide alloys .....                              | 15        |
| on determination of cuprous oxide in copper.....                              | 95        |
| Homogeneity in binary alloys, discussion of.....                              | 14        |
| factors governing.....  | 9, 10     |
| Homogeneous alloys, production of sampling of.....                            | 4, 21, 27 |
| Hot-ladle samples of doré bullion, analyses of.....                           | 32        |
| Howe, H. M., cited.....   | 16        |
| definitions by.....   | 17        |
| on diffusion in alloys.....   | 27        |
| Hunt, A. E., on action of aluminum on molten steel.....                       | 15, 16    |
| "Hypereutectic," definition of.....   | 19        |
| "Hypoeutectic," definition of.....  | 19        |
| I.  |           |
| Iron in copper bullion, proportion of removal of, from drilling samples ..... | 93, 94    |
| <i>See also</i> Pig iron.   |           |
| J.  |           |
| Jones, H. C., cited.....  | 27        |
| Jones sampler, figure showing.....  | 91        |
| L.  |           |
| Ladle samples. <i>See</i> Hot ladle samples; Skull samples.                   |           |
| Ladle sampling of doré bullion, results of.....                               | 32        |
| Lead bullion, molten, sampling of.....  | 33, 34    |
| sampling of, punch for.....   | 94, 95    |
| figure showing.....   | 95        |
| Lead in copper bullion, proportion of.....                                    | 22, 24    |
| Ledoux, A. R., cited.....   | 51        |
| templet for drilling devised by.....  | 53        |
| Leroux, A., cited.....  | 14        |
| Levol, A., on heterogeneity of copper-silver alloys.....                      | 11        |
| Liddell, D. M., cited.....  | 48        |
| on effect of bevel on sampling.....   | 43, 44    |
| on removal of iron from drillings samples.....                                | 94        |
| Liquidation, definitions of.....  | 17, 18    |
| M.  |           |
| McComas, K. W., acknowledgment to.....  | 3         |
| Martin, O. C., acknowledgment to.....   | 3         |
| Moisture in copper bullion, determination of.....                             | 38        |
| effect of.....  | 37, 38    |
| Mold wash, effect of, on drill samples.....                                   | 35, 36    |
| Molten metal, rapid cooling of, effect of.....                                | 10        |
| sampling of.....  | 31, 33-35 |
| factors governing.....  | 5         |
| stirring of, effect of.....   | 10        |
| stream of, sections of, figure showing.....                                   | 31        |
| Morse, W. S., on method of sampling copper bullion.....                       | 51, 52    |

|  | Page.  |
|--|--------|
| Neumann, B., cited.....  | 62     |
| Neville, F. H., cited.....   | 14     |
| on homogeneity of tin-copper alloy .....                                 | 14, 15 |
| Newton, F. C., acknowledgment to.....                                    | 3      |
| Nickel in copper bullion, proportion of .....                            | 24     |
| O.   |        |
| Oxygen in copper bullion, proportion of.....                             | 22     |
| P.   |        |
| Partial samples, taking of.....  | 5      |
| Peirce, W. H., acknowledgment to.....                                    | 3      |
| cited.....   | 37     |
| Percy, John, definition of liquation by .....                            | 17     |
| Pierce, N. W., acknowledgment to.....                                    | 3      |
| Pig iron, output of, in United States sampling of.....                   | 34     |
| Planing, method of sampling by.....                                      | 42, 43 |
| Plates, bullion, characteristics of.....                                 | 64     |
| distribution of metals in.....   | 64     |
| sampling of, factors in.....   | 48, 49 |
| methods of.....  | 48, 49 |
| structure of, variations in.....   | 50     |
| <i>See also</i> Bars; Slabs.   |        |
| Punch for sampling, figure showing.....                                  | 95     |
| use of.....  | 94, 95 |
| Punching, sampling by means of.....                                      | 49     |
| templet for, figure showing.....   | 52     |
| R.   |        |
| Raht, A., on sampling lead bullion.....                                  | 33, 52 |
| Raup, W. L., acknowledgment to.....                                      | 3      |
| Refinery assays of copper bullion, results of.....                       | 63     |
| Refinery samples of converter copper, average assays of, results of..... | 68     |
| comparative results of taking.....                                       | 74     |
| Roberts, W. C., cited.....   | 11     |
| Roberts-Austen, —, on freezing of copper-silver alloys.....              | 11     |
| Rolle, S., acknowledgment to.....  | 3      |
| S.   |        |
| Sampling, errors in, determination of .....                              | 68, 69 |
| precautions in.....  | 27, 28 |
| purpose of.....  | 4      |
| theories underlying, application of .....                                | 49, 50 |
| need of knowledge regarding .....  | 3      |
| <i>See also</i> Drilling; Sawing; Shot sampling.                         |        |
| Sappington, C. N., acknowledgment to .....                               | 3      |

|   | Page.                         | T.   |  | Page.     |
|---|-------------------------------|--|--|-----------|
| Sawed sample of converter copper, assay of, results of----- | 69                            | Tellurium in copper bullion, proportion of-----                                  |  | 22, 24    |
| Sawing, samples obtained by, analyses of-----               | 53                            | Template. <i>See</i> Templet.  |  |           |
| sampling by-----  | 42, 43, 49, 51.               | Templet, definition of-----  |  | 50        |
| description of-----   | 83, 84                        | diametral, sampling by means of, results of-----                                 |  | 75        |
| relative merits of-----                                     | 84, 96                        | dimensions of-----   |  | 84        |
| templet for, figure showing                                 | 51, 53                        | extent of surface covered by, factors governing-----                             |  | 54, 55    |
| Scrap, metallic, sampling of-----                           | 35                            | for drilling skulls, figure showing-----   |  | 29        |
| Screening of drillings, results of---                       | 92, 93                        | for sampling circular casting, figure showing-----                               |  | 56        |
| Segregation, definition of-----                             | 17, 18                        | for sampling by drilling, figure showing-----                                    |  | 52        |
| Selenium in copper bullion, proportion of-----              | 22, 24                        | for sampling by sawing, figure showing-----                                      |  | 51        |
| Shot sampling, economies in-----                            | 82                            | laying out, view of-----   |  | 86        |
| limitations of-----   | 82                            | rational, sampling by means of, results of-----                                  |  | 75        |
| merits of-----  | 82, 96                        | view of-----   |  | 84        |
| results of-----   | 28, 74, 83                    | Templet sections, shape of, factors governing-----                               |  | 53, 54    |
| Shotted samples, assays of, results of-----                 | 63, 65, 66, 68, 81            | size of-----   |  | 54        |
| errors in-----  | 30, 35                        | square, need of, figure showing-----   |  | 54        |
| method of obtaining-----                                    | 31, 32                        | Thayer, B. B., acknowledgment to--   |  | 3         |
| results of-----   | 28                            | Thomson, J. K., acknowledgment to method of marking drill hole locations by----- |  | 86        |
| figure showing-----   | 64                            | Tin-copper alloy, homogeneity of, factors determining-----                       |  | 14, 15    |
| Silver in copper bullion, assays of--                       | 81                            |  |  |           |
| determination of-----                                       | 13                            | U.   |  |           |
| distribution of-----  | 22, 62, 63, 65-69, 74, 78, 83 | Ungula of drill hole sample, figure showing-----                                 |  | 47        |
| figure showing-----   | 25, 26, 62, 64, 70            | volume of, calculation of-----   |  | 47        |
| proportion of-----  | 24, 66                        |  |  |           |
| in doré bullion, proportion of---                           | 32, 33                        | W.   |  |           |
| output of, in United States-----                            | 58                            | Walker, A. L., acknowledgment to--   |  | 3         |
| Skull samples of copper bullion, accuracy of-----           | 29, 30                        | Washoe plant, Anaconda, Mont., sampling method at-----                           |  | 31, 32    |
| drilling of, figure showing--                               | 29                            | Wels, P. O., on surface enrichment of converter copper bars---                   |  | 59        |
| results of taking-----                                      | 28                            | Western samples. <i>See</i> Smelter samples.                                     |  |           |
| of doré bullion, analyses of-----                           | 32                            | Wraith, William, on sampling molten metal-----                                   |  | 28, 30-32 |
| Slabs, bullion, sampling of, factors in-----                | 48, 49                        |  |  |           |
| <i>See also</i> Bars; Plates.                               |                               | Z.   |  |           |
| Smelter samples of copper bullion, assays of, results of--  | 63, 68, 74                    | Zinc in copper bullion, proportion of-----                                       |  | 24        |
| Smith, E. A. C., acknowledgment to--                        | 3                             |  |  |           |
| Smoot, A. M., cited-----                                    | 48                            |  |  |           |
| Solid alloys, sampling of, factors governing-----           | 5-10                          |  |  |           |
| need for-----   | 35                            |  |  |           |
| "Solute," definition of-----                                | 19                            |  |  |           |
| Solution, definition of-----                                | 16                            |  |  |           |
| "Solvent," definition of-----                               | 19                            |  |  |           |
| Stead, J. E., on errors in determination of alloys-----     | 10                            |  |  |           |
| Steel, carbon, diffusion of elements in-----                | 27                            |  |  |           |
| distribution of impurities in, determination of-----        | 23                            |  |  |           |
| removal of, from drillings samples-----                     | 93, 94                        |  |  |           |
| Sulphur in copper bullion, proportion of-----               | 22, 24                        |  |  |           |