

164
1-27-81
88

LA-8533

①

Dr. 2232

R-1422

MASTER

**Application of the Sealed-Reflux
Dissolution System to 100-Gram Samples**

University of California



LOS ALAMOS SCIENTIFIC LABORATORY

Post Office Box 1663 Los Alamos, New Mexico 87545

APPLICATION OF THE SEALED-REFLUX DISSOLUTION SYSTEM TO 100-GRAM SAMPLES

by

Rose Marie Gonzales de Duval, Joel W. Dahlby, and Adrian P. Lovell

ABSTRACT

We adapted the sealed-reflux dissolution system (described in Los Alamos Scientific Laboratory report LA-5576) to dissolve up to 100 g of refractory materials. The simplified pressurized-acid system was enlarged to accommodate a greater volume of acid and refractory materials. The acid and sample materials are heated between 150 and 190°C at a pressure of 0.14-0.20 MPa (20-29 psi). We also describe a second system for dissolving up to 5 g of refractory materials at 150°C and a pressure of 0.6 MPa (80 psi).

I. INTRODUCTION

The sealed-reflux dissolution system* was designed to dissolve approximately 0.5-g samples of high-fired plutonium oxide in a HNO₃-HCl-HF acid mixture. A rubber or polyethylene stopper is held in the tube opening by a spring clamp while the mixture is heated to 150-200°C to develop 0.3-0.8 MPa (50-115 psi) pressure.

This report describes modifications to the apparatus and system to expand its applicability to dissolution of samples as large as 100 g.

We increased the size of the dissolution tube and attached sidearms (Figs. 1-3). A pressure relief valve was incorporated (Fig. 4) and continuous mechanical mixing was used during the dissolution. With this larger system, approximately 500 mL of 15M HNO₃ and 5 mL of 13.5M HF are used, and the operating pressure is controlled at 0.14-0.20 MPa (20-29 psi). A temperature controller maintains the dissolution temperature up to 190°C.

*J. W. Dahlby, R. R. Geoffrion, and G. R. Waterbury, "The Sealed-Reflux Dissolution System," Los Alamos Scientific Laboratory report LA-5776 (January 1975), pp. 4-7.

In addition to the system for dissolving 100 g of plutonium oxide, a dissolution tube for 5-g samples is described.

II. LARGE SEALED-REFLUX TUBE APPARATUS AND REAGENTS

A shield should be positioned between the operator and equipment when operating this system. Pressure should not be released from the system until the temperature is <50°C. In case of accidental pressure release, a reservoir flask has been designed to collect the overflow of acid-sample mixture.

A. Apparatus

Argon Supply.

Baffle. A 228-mm-long Teflon rod, 9.5 mm o.d., with one end threaded at 19.05 mm to fit in a 7.94-mm drilled hole for a 9.5-mm tap in a machined conical Teflon rod that is 21.5 mm o.d. and 39 mm long. The other end fits into a similar tapped and threaded size 5 Teflon stopper (Fig. 5).

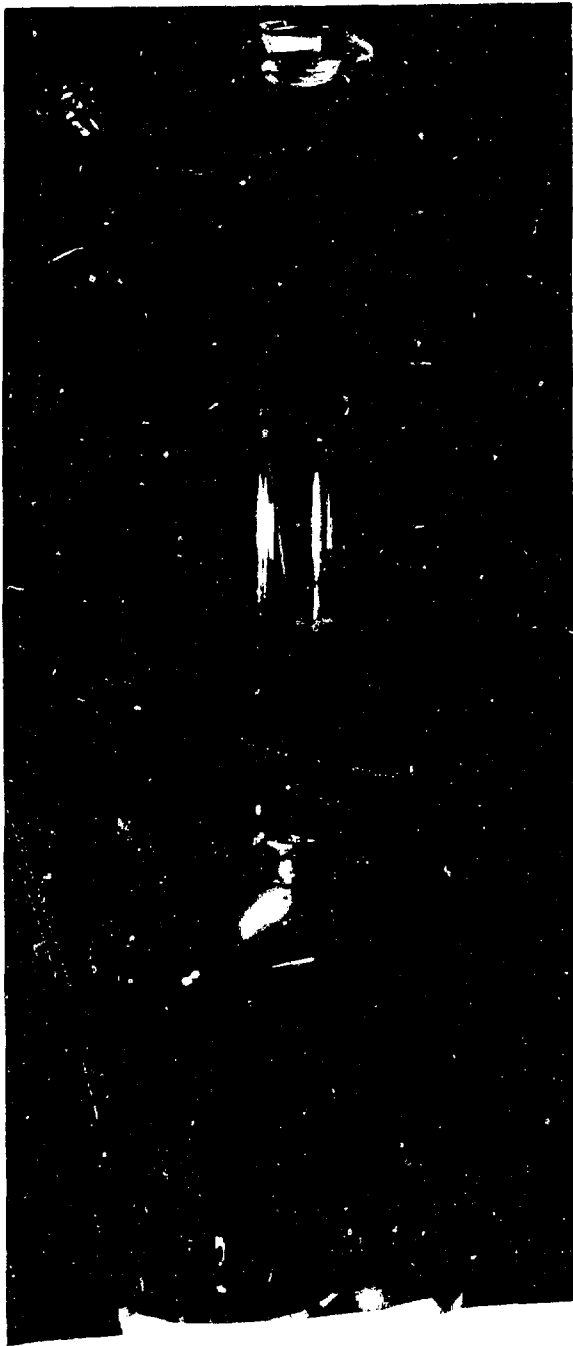

Fig. 1.
Dissolution tube.

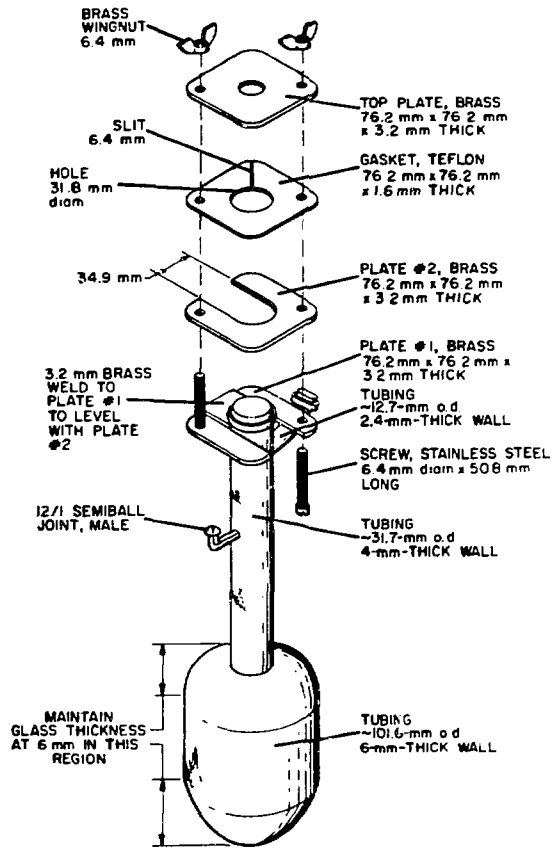

Fig. 2.
Teflon stopper clamp mounted on dissolution tube.

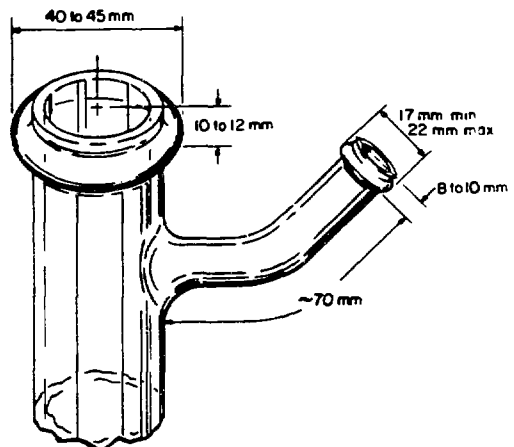

Fig. 3.
Dissolution tube clamping surface.

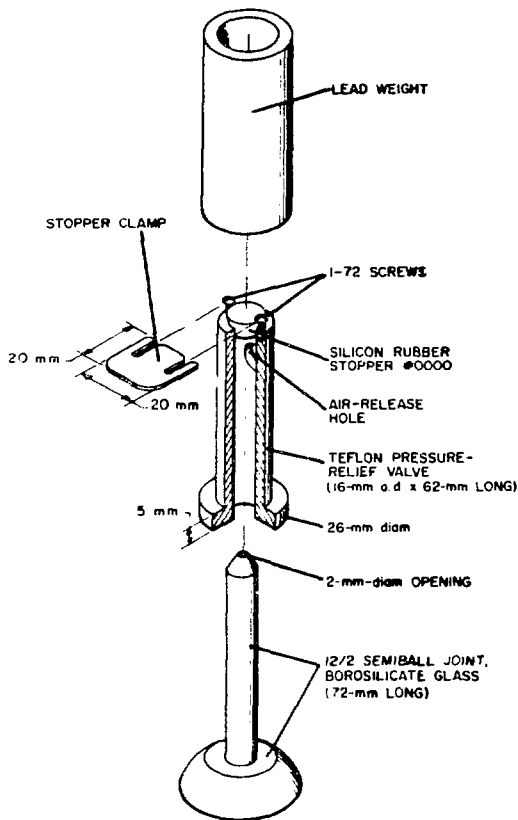

Fig. 4.
Pressure-relief valve.

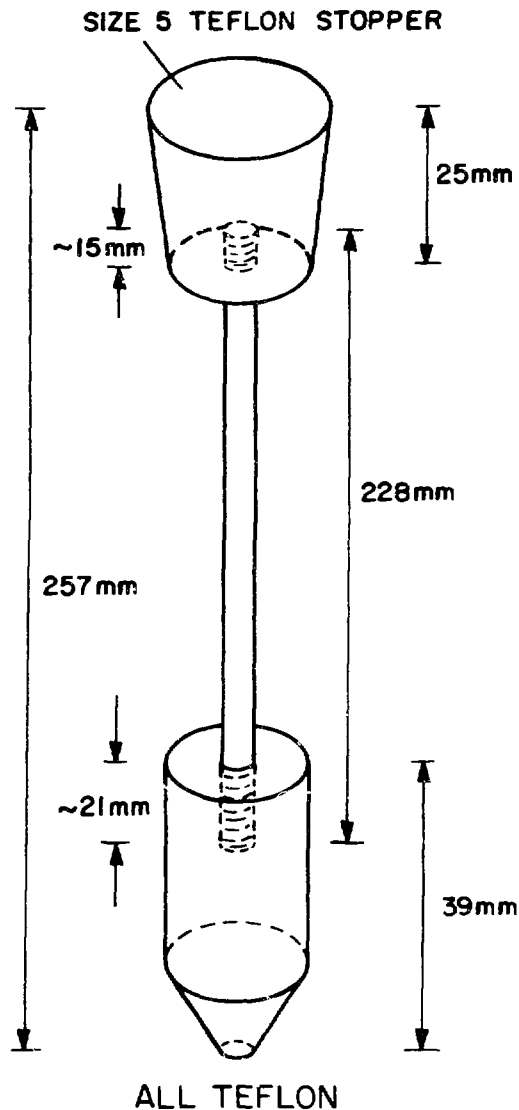

Fig. 5.
Baffle.

Clamp, Reservoir Flask. Stainless steel, top and bottom plates, 127 mm by 203 mm, 4 mm thick, with holes drilled on each corner (Fig. 6). Long (280-mm) screws are inserted through the holes and tightened with wing nuts. A hole just larger than the 12/3 semiball is drilled in the center of the top plate.

Clamp, Semiball, No. 12 and No. 18. The No. 18 clamps, modified by closing the opening on one side, are used to clamp stoppers.

Clamp, Teflon Stopper. Three brass plates, 76.2 mm by 76.2 mm, 3.2 mm thick, fitted with a 76.2-mm by 76.2-mm Teflon gasket, 1.6 mm thick, as shown in Fig. 2. The plates and gasket have two 6.4-mm holes drilled in diagonally opposed corners, fitted with 6.4-mm stainless steel screws, 50.8 mm long, with wing nuts to hold the clamp together. The top plate has a 10-mm hole drilled in the center and the other two plates have a 34.9-mm slot as shown in Fig. 2. The bottom plate is reversed with respect to the middle plate in the assembly.

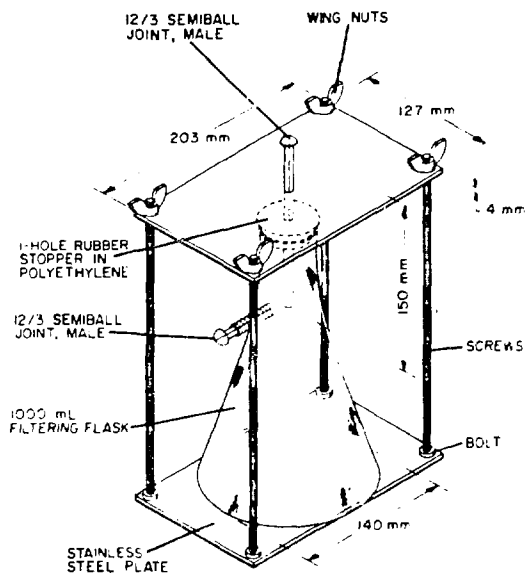

Fig. 6.
Reservoir flask and clamp.

A 3.2-mm-thick piece of brass is brazed to the bottom plate (Fig. 2) to fill part of the slot in the middle plate when the clamp is assembled.

Dissolution Tube. Borosilicate glass made from a 101-mm-o.d., 6-mm-thick-wall glass tube, 170 mm long, with one end finished in a round test-tube-like seal. The other end is attached to a 31.7-mm-o.d., 4-mm-thick-wall, 240-mm-long tube. The top is then shaped to be a clamping surface. A 12/1 male semiball joint that has a 90° angle is attached approximately 110 mm from the top. On the opposite side, approximately 50 mm from the top, a sidearm of 12.7-mm-o.d., 2.3-mm-thick glass tubing is attached. The top end of the sidearm is shaped to be a clamping surface (Figs. 1-3).

Funnel. Plain, borosilicate glass, for adding acid to dissolution tube, 50 mm i.d., with the stem approximately 70 mm long and bent to approximately 45° angle (Fig. 7).

Heating Block. Brass cylinder sealed with a brass plate on one end, wrapped with a heating tape and insulated. The brass cylinder measures 103 mm i.d., cut to a depth of 119 mm (Fig. 8).

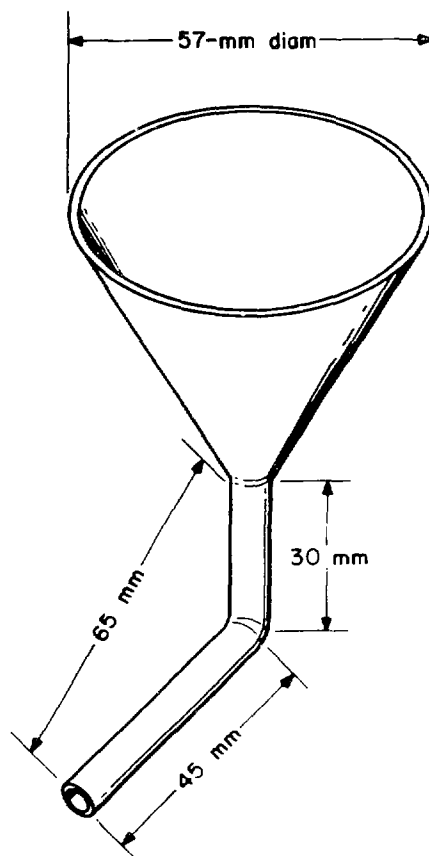

Fig. 7.
Funnel.

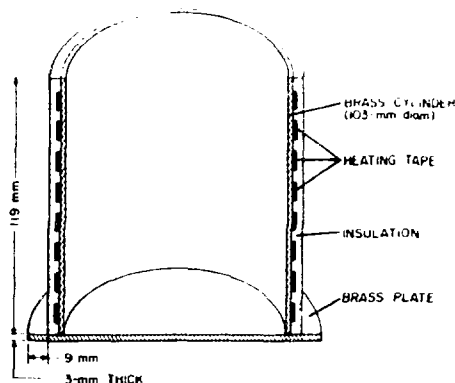

Fig. 8.
Heating block.

Hose Clamp. Adjustable opening, 5.6 mm to 15.9 mm.

Laboratory Equipment. 500-mL graduated cylinder, beakers.

Magnetic Mixer.

Polyethylene Stoppers. Size 0 cut to 15-mm length with a size 0000 rubber stopper inserted. A size 9 with one hole in the middle, with a size 8 one-hole rubber stopper inserted into it.

Pressure Gauge. 0-100 psi, dial-type.

Pressure-Relief Valve. Teflon tube, 16 mm o.d. by 62 mm long, fitted with two 1-72 iron screws on either side of a hole to fit a size 0000 stopper, with an air-release hole in the side wall, and made to fit over and slide freely on a 12/2 semiball joint borosilicate glass tube. A lead weight fits over the Teflon tube. A size 0000 silicone rubber stopper is inserted into the Teflon tube. The stopper is clamped by a slotted 20-mm by 20-mm copper plate that fits over the stopper and slots into the screws. This entire valve assembly should weigh approximately 181.2 g (Fig. 4).

Reservoir Flask. A 1000-mL filtering flask with a 20-mm-long, male 12/3 semiball joint tube attached to the sidearm. The flask is then fitted with a size 9 one-hole polyethylene stopper containing a size 8 one-hole rubber stopper. Through the hole, a male 12/3 semiball joint tube, 150 mm long, is inserted (Fig. 6).

Rubber Stoppers. A size 0000, cut to 15-mm length, and a size 8 one-hole; both inserted into polyethylene stoppers.

Semiball Joints. Various lengths and sizes to make connections in the system.

Silicone Rubber Stopper. Size 0000.

Stir Bar. Magnetic, 52 mm long, fitted with a Teflon sleeve that is used as a pivot.

Teflon Stopper. Machined to the approximate size of a size 5 rubber stopper, threaded at 3/4 in. on the bottom center side (Fig. 5).

Temperature Controller. Love controller or equivalent, and a powerstat variac wired as one unit to provide temperature control.

Thermocouple. Chromel-Alumel.

Tygon Tubing. For connections from argon supply to system.

Vacuum Grease. Dow-Corning High Vacuum Grease or equivalent silicone lubricant that resists melting for greasing ball joint connections.

B. Reagents

Hydrofluoric Acid. 27M, reagent grade.

Hydrofluoric Acid. 13.5M, prepared by adding 50 mL of 27M HF, reagent grade, to 50 mL of double-distilled water.

Nitric Acid. 15M, reagent grade.

Water. Double-distilled.

III. RECOMMENDED PROCEDURE

- A. Place weighed sample (up to 100 g) in a clean dissolution tube that is sitting in the heating block. Place a magnetic stir bar in the tube. Insert the baffle, and clamp the Teflon stopper in place.
- B. Insert the modified funnel through the sidearm and add 5 mL of 13.5M HF and 500 mL of 15M HNO₃. Stopper and clamp with modified No. 18 semiball joint clamp.
- C. Grease all ball joints with vacuum grease and connect with No. 12 semiball joint clamps. Set pressure-relief valve in place, making certain it is vertical. When the system is completely connected, it should appear as in Fig. 9. (Figure 9 shows an experimental glass baffle in place.)
- D. Raise the flow rate to 100 cm³/min from an argon supply for ~2 min; then adjust the flow rate to ~20 cm³/min until a system pressure of 0.14-0.20

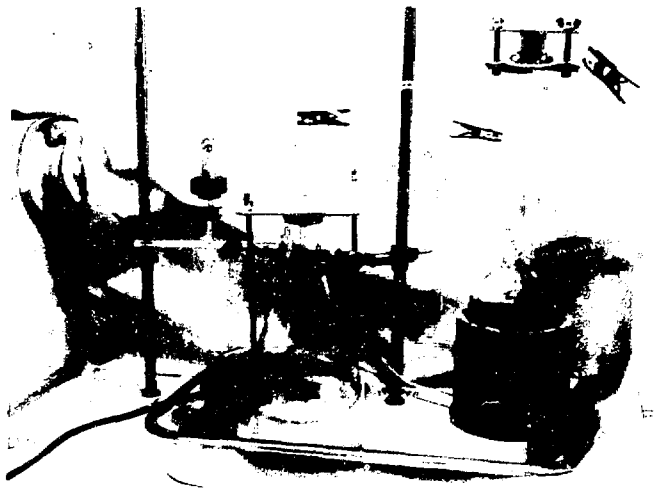

Fig. 9.
Large sealed-reflux dissolution system.

MPa (20-29 psi) is maintained. If the pressure does not remain constant, check all connections and stoppers.

- E. Once the system is pressurized, start the mixer, apply heat adjusted by the controller to maintain a temperature of 190°C , and continue constant mixing until the sample dissolves. The dissolution time should be determined according to the history of each plutonium oxide sample; normally, ~ 5 h is required.
- F. Turn the heat off and let the apparatus cool to $<50^{\circ}\text{C}$ before turning argon off.
- G. When cooled to $<50^{\circ}\text{C}$, turn the argon off and release the pressure slowly by lifting the pressure-relief valve slightly; then lift off the pressure-relief valve and disconnect the system.
- H. Quantitatively transfer the solution to a suitable container, mix well, and take the required aliquots for analysis.

IV. EXPERIMENTAL CONDITIONS

To determine optimum conditions for dissolution, acid mixtures were tried at various temperatures and conditions. The pressure in all tests was maintained between 0.14 and 0.20 MPa by the pressure-relief valve.

The large internal diameter of the neck of the dissolution vessel allowed easy circulation of gas but caused excessive cooling of the acid. Some experiments were done with a baffle (Fig. 5) to reduce this circulation and allow the dissolving acid mixture to reach a higher temperature for quicker dissolution.

Temperature changes were measured with and without a baffle to determine whether the temperature of the acid solution could be increased. With the baffle in place, the temperature was higher than without it (Table I). The baffle also controlled acid spillage during a simulated pressure loss with the acid at a high temperature.

Initially, the large sealed-reflux dissolution system was tried without mechanical mixing and the results of repeated dissolutions showed that a considerable amount of undissolved sample remained. When the samples were continuously mixed during the entire 5 h dissolution time, complete dissolution was accomplished. Three samples, each containing ~ 100 g of plutonium oxide, were completely dissolved using this method.

All plutonium oxide samples were high-fired at 950°C in air for 2-3 h before dissolution. Time for dissolution should be determined for each sample after reviewing its ignition history. The 100-g plutonium oxide samples used in this study required ~ 5 h to dissolve once the desired temperature was reached.

The $15M$ HNO_3 acid mixtures were more effective solvents for plutonium oxide than the $6M$ HCl acid mixtures because pressure and temperature were more easily maintained.

TABLE I

EFFECT OF BAFFLE ON SOLUTION TEMPERATURE

System Pressure = 0.14 MPa (20 psi)

Acid Mixture	Time (h)	Acid Temperature (°C)
6M HCl without baffle	0	26
	1	70
	2	120
	3	120
	4	120
6M HCl with baffle	0	26
	1	98
	2	118
	3	124
	4	126 ^a
15M HNO ₃ without baffle	0	26
	1	98
	2	128
	3	130
	4	130
15M HNO ₃ with baffle	0	40
	1	70
	2	116
	3	138
	4	138

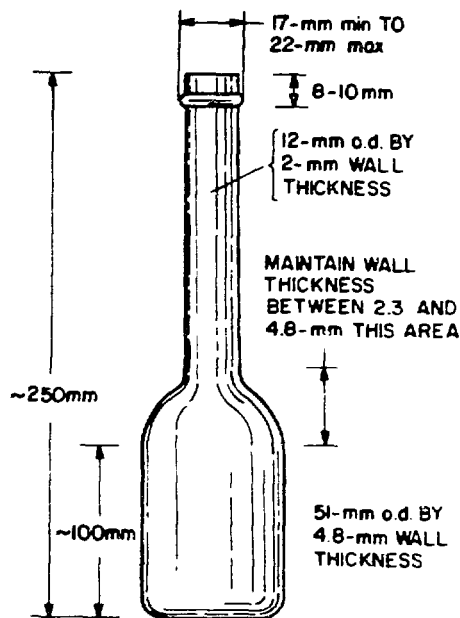
^aSolution began to boil.Fig. 10.
Dissolution tube for 5-g samples.

150°C is approximately 0.57 MPa (82 psi). A dissolution temperature of 150°C for the heating block is recommended. The heating block should be made so the dissolution tube inserts into it just to the level of the top of the acid.

The system for dissolving up to 5 g of plutonium oxide material does not follow the Recommended Procedure (Sec. III) of this report. Except for the modifications, the procedure outlined in Sec. V of Los Alamos Scientific Laboratory report LA 5776 is to be followed.

V. MODIFICATIONS TO DISSOLVE 5-g PLUTONIUM OXIDE SAMPLES

In addition to the system for dissolving 100-g samples, simpler modifications were made to the sealed-reflux dissolution system to apply the method to 5-g samples. These modifications were the use of a larger dissolution tube, more acid mixture, and a heating block with larger holes to fit the larger tubes. The original dissolution tube was modified by adding a 51-mm-o.d., 100-mm-high, thick-walled dissolution flask bottom to the tube (Fig. 10). The acid quantities were measured to 20 mL of 12M HCl, 0.5 mL of 15M HNO₃, and 1 mL of 1.3M HF. The pressure developed by the acid mixture in this system at

VI. DISCUSSION

The large sealed-reflux dissolution system can quickly dissolve large amounts of plutonium oxide samples in a closed system. The applied temperature of the system makes it possible to heat solutions to temperatures higher than their normal boiling points. The baffle in the system reduces the gas-phase temperature and effects a higher acid temperature. In case of accidental release of pressure, a reservoir flask has been added to trap any solution that may be spilled. This system proved safe under tests simulating accidental pressure release. The rubber and polyethylene stoppers deteriorate with the acid fumes and must be replaced with each sample. The

Teflon stopper, which is an integral part of the baffle, can be reused. This system is safe and reliable for dissolving up to 100 g of high-fired plutonium oxide samples in 5 h in a clean solution of HNO_3 -HF, while the acid fumes are contained, minimizing corrosion of the containment box.

The tubes and acid mixtures for dissolving 5-g samples have been repeatedly tested with satisfactory results. Usually, this size tube is adequate for dissolving analytical chemistry samples, but the large sealed-reflux

dissolution system should be used if dissolution of larger quantities is required. The large system is more efficient and is safer than repeatedly dissolving smaller (5 g) samples.

VII. ACKNOWLEDGMENTS

We acknowledge the contributions of Rosalind K. Newmeyer.