

180  
1-12-81  
R 1094

1

Dr. 2182

DOE/MC/08333-2

MASTER

STATE-OF-THE-ART REVIEW OF NITROGEN AND FLUE GAS FLOODING IN ENHANCED OIL RECOVERY

Final Report

Work Performed for the Department of Energy Under Contract DE-AT21-78MC08333

Date Published — December 1980

NOTICE  
PORTIONS OF THIS REPORT ARE ILLEGIBLE.  
It has been reproduced from the best available copy to permit the broadest possible availability.

Science Applications, Inc.  
Morgantown, West Virginia



U. S. DEPARTMENT OF ENERGY

DISTRIBUTION OF THIS DOCUMENT IS UNLIMITED

## DISCLAIMER

**This report was prepared as an account of work sponsored by an agency of the United States Government. Neither the United States Government nor any agency Thereof, nor any of their employees, makes any warranty, express or implied, or assumes any legal liability or responsibility for the accuracy, completeness, or usefulness of any information, apparatus, product, or process disclosed, or represents that its use would not infringe privately owned rights. Reference herein to any specific commercial product, process, or service by trade name, trademark, manufacturer, or otherwise does not necessarily constitute or imply its endorsement, recommendation, or favoring by the United States Government or any agency thereof. The views and opinions of authors expressed herein do not necessarily state or reflect those of the United States Government or any agency thereof.**

## **DISCLAIMER**

**Portions of this document may be illegible in electronic image products. Images are produced from the best available original document.**

## DISCLAIMER

"This book was prepared as an account of work sponsored by an agency of the United States Government. Neither the United States Government nor any agency thereof, nor any of their employees, makes any warranty, express or implied, or assumes any legal liability or responsibility for the accuracy, completeness, or usefulness of any information, apparatus, product, or process disclosed, or represents that its use would not infringe privately owned rights. Reference herein to any specific commercial product, process, or service by trade name, trademark, manufacturer, or otherwise, does not necessarily constitute or imply its endorsement, recommendation, or favoring by the United States Government or any agency thereof. The views and opinions of authors expressed herein do not necessarily state or reflect those of the United States Government or any agency thereof."

Available from the National Technical Information Service, U.S. Department of Commerce, Springfield, Virginia 22161.

### NTIS price codes

Paper copy: \$10.00

Microfiche copy: \$ 3.50

R1094

Di. 2182

DOE/MC/08333-2  
Distribution Category UC-92a

Master

STATE-OF-THE-ART REVIEW OF NITROGEN AND FLUE GAS FLOODING  
IN ENHANCED OIL RECOVERY

Final Report

Harish R. Anada, *Principal Investigator*  
Science Applications, Inc.  
Chestnut Ridge Professional Building, Suite 8  
Morgantown, West Virginia 26505  
304/599-9696

Royal J. Watts, *Technical Project Officer*  
Morgantown Energy Technology Center  
P.O. Box 880  
Morgantown, West Virginia 26505  
304/599-7218

Date Published — December 1980

Work Performed for the Department of Energy  
Under Contract DE-AT21-78MC08333

U.S. DEPARTMENT OF ENERGY

DISCLAIMER

This book was prepared as an account of work sponsored by an agency of the United States Government. Neither the United States Government nor any agency thereof, nor any of their employees, makes any warranty, express or implied, or assumes any legal liability or responsibility for the accuracy, completeness, or usefulness of any information, apparatus, product, or process disclosed, or represents that its use would not infringe privately owned rights. Reference herein to any specific commercial product, process, or service by trade name, trademark, manufacturer, or otherwise, does not necessarily constitute or imply its endorsement, recommendation, or favoring by the United States Government or any agency thereof. The views and opinions of authors expressed herein do not necessarily state or reflect those of the United States Government or any agency thereof.

DISTRIBUTION OF THIS DOCUMENT IS UNLIMITED

## TABLE OF CONTENTS

	<u>Page</u>
List of Exhibits .....	iii
Acknowledgement .....	v
Abstract .....	vi
1. Introduction and Summary .....	1
2. Physical and Chemical Characteristics of Nitrogen and Flue Gas .....	5
2.1 Nitrogen .....	5
2.2 Flue Gas .....	11
References .....	12
3. Applied Research Activities .....	14
3.1 Nitrogen Injection .....	14
3.2 Flue Gas Injection .....	35
3.3 Other Gases (Excluding CO <sub>2</sub> and Hydrocarbon Gases) .....	40
References .....	43
4. Field Based Activities .....	45
4.1 Nitrogen Injection .....	46
4.2 Flue Gas Injection .....	55
4.3 Air Injection .....	72
References .....	76
5. Source, Supply and Cost Data for Utilizing Nitrogen and Flue Gas in EOR Operations .....	78
5.1 Availability and Costs of Nitrogen .....	78
5.2 Availability and Costs of Flue Gases .....	88
5.3 Cost Comparison of Nitrogen/Flue Gas for EOR .....	96
5.4 Conclusions .....	96
References .....	100
6. Discussion on Process and Reservoir Parameters .....	101
6.1 Process Parameters .....	101
6.2 Reservoir Parameters .....	104
References .....	107
7. Comparison and Conclusions .....	109
7.1 Comparison .....	109
7.2 Conclusions .....	111
Appendix A - Bibliography on N <sub>2</sub> Flooding .....	113
Appendix B - Bibliography on Flue Gas Flooding .....	116
Appendix C - Bibliography on Patent Literature .....	118

LIST OF EXHIBITS

<u>Exhibit No.</u>		<u>Page</u>
2-1	Density of CO <sub>2</sub> , N <sub>2</sub> , and Flue Gas (87% N <sub>2</sub> , 13% CO <sub>2</sub> ) with Varying Pressures and Temperatures . . . . .	6
2-2	Compressibility of N <sub>2</sub> , CO <sub>2</sub> , and Flue Gas (87% N <sub>2</sub> , 13% CO <sub>2</sub> ) with Varying Pressures and Temperatures . . . . .	8
2-3	Nitrogen Solubility as a Function of Pressure . . . . .	9
2-4	Gas Formation Volume Factors for CO <sub>2</sub> , N <sub>2</sub> and Flue Gas (78% N <sub>2</sub> , 13% CO <sub>2</sub> ) with Varying Pressures and Temperatures . . . . .	10
3-1	Effect of Pressure on Oil Recovery Using High-Pressure Nitrogen Injection . . . . .	16
3-2	Effect of Temperature on Oil Recovery Using High-Pressure Nitrogen Injection . . . . .	17
3-3	Slim Tube Experiments on Painter Reservoir Oil Using Nitrogen and Carbon Dioxide . . . . .	18
3-4	Condensate Slim Tube Recovery by N <sub>2</sub> . . . . .	19
3-5	Slim Tube Experiments with N <sub>2</sub> Using Painter Reservoir Black Oil. . . . .	20
3-6	A Comparison of Oil Recovery by Injection of Carbon Dioxide and Nitrogen Using Crude Containing No Solution Gas . . . . .	22
3-7	Oil Recovery by CO <sub>2</sub> Slugs Pushed by Nitrogen for the Wasson Crude . . . . .	23
3-8	Compositions and Properties of Reservoir Fluids . . . . .	26
3-9	Effect of Nitrogen Contact on Oil Properties . . . . .	27
3-10	Effect of Nitrogen Contact on Oil Composition (Mol %) . . . . .	28
3-11	Reservoir Fluid Composition . . . . .	29
3-12	Retrograde Condensation During Depletion at 200°F (93.3°C) . . . . .	30
3-13	Dew Point Elevation with Nitrogen and Lean Gas . . . . .	32
3-14	Properties of Hypothetical Reservoir and Three Reservoir Fluids. . . . .	33
3-15	Stock-Tank Liquid Content and Retrograde Liquid Saturation . . . . .	34
3-16	Reduction in Heavy Crude Viscosity Can Be Obtained From Small Amount of CO <sub>2</sub> in Solution. . . . .	37
3-17	Properties of Reservoir Fluids and Gas Composition . . . . .	38
3-18	Convergence Pressure of Methane and Petroleum Fractions . . . . .	41
4-1	Active Enhanced Oil Recovery Projects in the United States by EOR Method. . . . .	45
4-2	The Location of Fordoche Field . . . . .	47
4-3	Location Map of Ryckman Creek Field, Uinta County, Wyoming . . . . .	49
4-4	Status and Structure Map of Ryckman Creek Field . . . . .	51
4-5	Structure Map of Devonian Formation of Block 31 Field . . . . .	58
4-6	Well Locations in Neale Field . . . . .	60
4-7	Geologic Cross Section of Elk Basin Field . . . . .	62
4-8	Sand-Top Isobars, Superimposed on Structure Map, Elk Basin Tensleep Reservoir . . . . .	63
4-9	Performance Plots of Slaughter Estate Unit Tertiary Pilot Test . . . . .	67
4-10	Structure Contour Map of Gralino 'A' and Bullock-Burke Sand Iberia Field . . . . .	68
4-11	Performance Curve of West Heidelberg Cotton Valley Unit . . . . .	71
4-12	Structure Map of Willow Draw Field, Park Co., Wyoming . . . . .	73
4-13	Oil and Water Production, Willow Draw Field, Wyoming . . . . .	74
5-1	Schematic Diagram of Cryogenic Process for Nitrogen Production . . . . .	80
5-2	Fixed Cost - Nitrogen Generation . . . . .	82
5-3	Energy Cost - Nitrogen Generation . . . . .	83

<u>Exhibit No.</u>		<u>Page</u>
5-4	Typical Cost Component of Nitrogen . . . . .	85
5-5	Schematic Diagram of Flue Gas (Boiler Gas) Generation Process. . . . .	89
5-6	Schematic Diagram of Flue Gas (Engine Exhaust Gas) Generation Process. . . . .	90
5-7	Fixed Cost - Boiler Flue Gas Generation . . . . .	91
5-8	Energy Cost - Flue Gas Generation Facilities as a Function of Natural Gas Price . . . . .	93
5-9	Schematic Diagram of Flue Gas Processing for EOR . . . . .	95
5-10	Fixed Cost - N <sub>2</sub> and Flue Gas Production Facilities . . . . .	97
5-11	Energy Costs - Nitrogen and Flue Gas Production Facilities . . . . .	98
5-12	Approximate Total Costs of N <sub>2</sub> and Flue Gas . . . . .	99



### Acknowledgement

The writer gratefully acknowledges the assistance of the following persons in preparing this report:

Keith Horan, Patrick Kujawa, Mariano Neira, Doug Kreshover, and Philip Lawson for technical assistance;

J. Pasini III, Patrick Kujawa, Royal J. Watts, James Wasson, Teresa Monger, and J. W. Cunningham for review;

Kate Lessing for editing; Carol Molisee and Sharon Hillberry for typing; and Richard Deaner and David Martin for drafting.

A special thanks goes to Dr. Keith Wilson of Air Products and Chemicals, Inc., for providing nitrogen and flue gas generation cost data.

ABSTRACT

This report provides a review of technical publications and patents in the field of nitrogen and flue gas flooding in Enhanced Oil Recovery (EOR). The physical and chemical characteristics of nitrogen and flue gas are provided with some comparisons with CO<sub>2</sub> related to EOR operations. Experimental research and field based activities using nitrogen and flue gas are briefly summarized. Cost data for generation of nitrogen and flue gases are provided. Nitrogen and flue gas costs are approximately one third to one half that of CO<sub>2</sub>. The low cost of production and its non-corrosive nature are advantages of using nitrogen, whereas the higher miscibility pressure requirement is a disadvantage. Nitrogen flooding does not work well with low API gravity crudes. Miscible displacement with nitrogen seems promising for oils containing solution gas. Flue gas flooding can be applied to low API gravity crude reservoirs. However, flue gas flooding creates operating problems due to its corrosive nature. The report provides a discussion on process and reservoir parameters that affect nitrogen and/or flue gas flooding in EOR. A bibliography of related literature is provided in the appendices.

## 1. INTRODUCTION AND SUMMARY

The objective of this state-of-the-art review of nitrogen and flue gas flooding as used in enhanced oil recovery is:

- to assemble all the available literature on this subject and prepare a bibliography, and
- to review the literature and present:
  - The physical and chemical characteristics,
  - A summary of applied research and field activities,
  - Source/supply/cost data,
  - Process and reservoir parameters, and
  - A comparison of  $N_2$  and flue gas flooding with  $CO_2$  flooding.

Literature was searched using a two pronged approach. Abstracts as well as periodicals were reviewed so that if relevant material were missed in abstract form, it would be noted in periodicals, and vice versa. The literature review was restricted to the publication period of 1960 through the present. However, cross references in this literature were sought, even if published prior to 1960. The journals and periodicals that were searched included: Petroleum Abstracts, Energy Research Abstracts (by DOE), Petroleum Engineer, Journal of Petroleum Technology (JPT), AIME Petroleum Transactions, Petroleum Times, SPE Journals, SPE EOR Field Reports, Oil and Gas Journal, and World Oil.

In addition, a computer assisted literature search was conducted using Morgantown Energy Technology Center's files on the Petroleum Energy Data Bases. Various combinations of key words such as gas injection, nitrogen, flue gas, stack gas, secondary recovery, and enhanced recovery were used. A patent search was also made in order to obtain pertinent information unpublished in journals and periodicals.

The bibliography of articles that are directly or indirectly related to the use of nitrogen and flue gas are presented in Appendices A, B, and C. In addition, references are provided at the end of each Section. Appendix A presents a bibliography of articles related to nitrogen flooding. Appendix B presents a bibliography of articles related to flue gas flooding. Appendix C presents a list of patents related to nitrogen and flue gas flooding.

Subsections within the appendices include sets of articles that are related to specific topics such as physical/chemical characteristics, source/supply cost data, etc. However, an article or a patent may fall into more than one subsection.

All literature thus collected was reviewed and the results are presented in Sections 2 through 7.

Section 2 presents the physical and chemical properties of nitrogen and flue gas and their significance for use in enhanced oil recovery (EOR). Nitrogen is less corrosive than  $\text{CO}_2$  and flue gas. Flue gas is more corrosive than  $\text{CO}_2$  because of associated impurities. Pure nitrogen has a higher miscibility and dew point pressure than  $\text{CO}_2$  or flue gas. Nitrogen is less soluble in water or brine than  $\text{CO}_2$ . The solubility of flue gas falls in between nitrogen and  $\text{CO}_2$ , and depends upon its composition.

Injection gas properties such as corrosiveness, miscibility pressure and solubility are very important in Enhanced Oil Recovery operations because:

- o If the gases are corrosive, they will have adverse effects on the injection and production wells and on surface equipment.
- o There is a direct relationship between the miscibility pressure and injection cost. High miscibility pressure requirements will prevent the process from being applied in shallow reservoirs.
- o The solubility of gas in oil affects the viscosity reduction of oil. This is important in miscible displacement operations. The solubility of injection gas in connate water is important for pressurizing the reservoir.

These and other physical properties of nitrogen and flue gas and their significance in EOR are further discussed in Section 2.

Section 3 presents a discussion on conceptual process development and laboratory experimental tests performed: on miscible displacement using nitrogen; the use of nitrogen injection for pressure maintenance and retrograde condensation; and flue gas flooding and other gases (excluding  $\text{CO}_2$  and hydrocarbon gases). The results indicate that nitrogen requires higher miscibility pressures than  $\text{CO}_2$ . Miscible displacement using nitrogen is promising when the oil contains solution gas. However, the technique does not work well with dead oils (containing essentially no solution gas). Thus, it appears that  $\text{N}_2$  flooding would be suitable for reservoirs with crude oils of more than 35 degrees API, and would require higher pressures than that necessary for  $\text{CO}_2$  flooding.  $\text{CO}_2$  slugs followed by nitrogen injection appear

to be a very promising process for use in lower API gravity (less than 35° API) crudes where N<sub>2</sub> alone can not be used. This will reduce CO<sub>2</sub> consumption considerably. This technique does not require very high pressures. The use of nitrogen for pressure maintenance and retrograde condensation is very promising. Flue gas flooding is suitable for heavy oil reservoirs. Here, the CO<sub>2</sub> component of the flue gas dissolves in oil and reduces the oil's viscosity. Nitrogen provides the energy for pressure build-up and "chases out" the oil. However, flue gas flooding creates operating problems due to its corrosive nature.

Section 4 provides a summary of field based projects using nitrogen, flue gas and air injection in EOR. Promising results have been obtained from some field tests (e.g., Fordoche Field using nitrogen flooding for pressure maintenance, and Block 31 Field using flue gas flooding for miscible displacement). The field project discussion includes available information on location and general history, geologic and petrophysical data, and reservoir performance.

Section 5 provides source, supply, and cost data for the use of nitrogen and flue gas in EOR operations. Nitrogen is readily available since it can be manufactured on-site from the air. CO<sub>2</sub> is not readily available. In past field operations, flue gas was obtained from either engine exhaust or the incineration of lean gas produced from a reservoir. With the near-future technological development of synfuels, tremendous amounts of flue gas will be produced. These could serve as a source of supply for flue gas or CO<sub>2</sub>.

The reported costs of nitrogen, CO<sub>2</sub>, and flue gas in EOR are presented in the Table below. A discussion on various cost components and processes for nitrogen and flue gas generation is provided in Section 5.

Gas	Reported Costs		Reference
	\$/MCF*	cents/m <sup>3</sup>	
Nitrogen	0.40 to 0.51	1.4 to 1.8	5-2
			5-5
CO <sub>2</sub>	1.00 to 1.25	3.53 to 4.41	5-5
Flue Gases	0.55 to 0.82	1.94 to 2.90	5-2
			5-5

MCF = 10<sup>3</sup> cubic foot

Section 6 provides a discussion on reservoir and process parameters for nitrogen and flue gas. A candidate reservoir using nitrogen would be a light oil reservoir with crude oil of over 35 degrees API, containing solution gas. The reservoir should be deep enough to withstand miscibility pressures in excess of 4000 psi. Flue gas flooding can be used in a shallow, heavy oil reservoir with an API gravity of 10 to 25 degrees.

Section 7 provides a comparison of nitrogen and flue gas flooding with CO<sub>2</sub> flooding. It also presents conclusions based on this study. It is suggested that nitrogen flooding is technically feasible. Nitrogen appears to be better than natural gas for use as an injection material in pressure maintenance and retrograde condensation. CO<sub>2</sub> slugs followed by nitrogen flooding appears to be the best approach for miscible displacement in EOR, and should be studied further. Flue gas flooding has been applied in the past with some success; however, its corrosive nature requires special treatment to remove corrosive components (specifically sulfur compounds and moisture) and/or special equipment for handling the flue gas and petroleum products. However, new large-size fossil fuel plants will be constructed in the next decade, and thus, large amounts of flue gas will be available at minimal cost. It appears that if flue gas is to be used, it should be used without much conditioning or treatment, except for the removal of moisture (since sulfur compounds are not corrosive in the absence of moisture). Sulfur compounds (SO<sub>2</sub> and H<sub>2</sub>S) have positive effects on enhanced oil recovery, specifically in carbonate reservoirs where they should not create any problems at production wells and in separation facilities. In addition to its corrosive nature, another disadvantage of flue gas includes the necessity of constructing nitrogen rejection facilities at the product separator facilities.

## 2. PHYSICAL AND CHEMICAL CHARACTERISTICS OF NITROGEN AND FLUE GAS

### 2.1 NITROGEN

The physical and chemical properties of nitrogen are presented below. The significance of these properties with respect to EOR is discussed.

<u>Parameter</u>	Conventional Units	SI Metric Units	Remark	Ref
Molecular Weight	28.013	28.013		2-1
Boiling Point (B.P.)	-320.4 <sup>0</sup> F	-195.78 <sup>0</sup> C		2-2
Melting Point (M.P.)	-345.8 <sup>0</sup> F	-209.89 <sup>0</sup> C		2-1
Critical Temperature (T <sub>c</sub> )	-232 <sup>0</sup> F	-144.67 <sup>0</sup> C		2-1
Critical Pressure (P <sub>c</sub> )	492.8 psi	3.398 MPa		2-1
Critical Volume (V <sub>c</sub> )	39.96 ft <sup>3</sup> /lb mole	89.05 cm <sup>3</sup> /gm mole		2-1
Density	.7725 lb/ft <sup>3</sup>	.001165 g/cm <sup>3</sup>	1	2-3
Specific Gravity	1.026 at -422.5 <sup>0</sup> F	1.026 at -252.5 <sup>0</sup> C		2-3, 2-19
	0.808 at -320.4 <sup>0</sup> F	0.808 at -195.8 <sup>0</sup> C		
Thermal Conductivity	0.145 Btu/Hr (ft <sup>2</sup> )( <sup>0</sup> F/ft) at 68 <sup>0</sup> F	6x10 <sup>-5</sup> Cal/sec (cm <sup>2</sup> )( <sup>0</sup> C/cm) at 20 <sup>0</sup> C		2-3
Compressibility Factor (Z <sub>c</sub> )	.291	.291	2	2-1, 2-2, 2-4

#### Remarks

1. A plot of the density of nitrogen, CO<sub>2</sub>, and flue gas vs. temperature and pressure is shown in Exhibit 2-1. The densities of flue gas were calculated using 87 percent N<sub>2</sub> and 13 percent CO<sub>2</sub>.

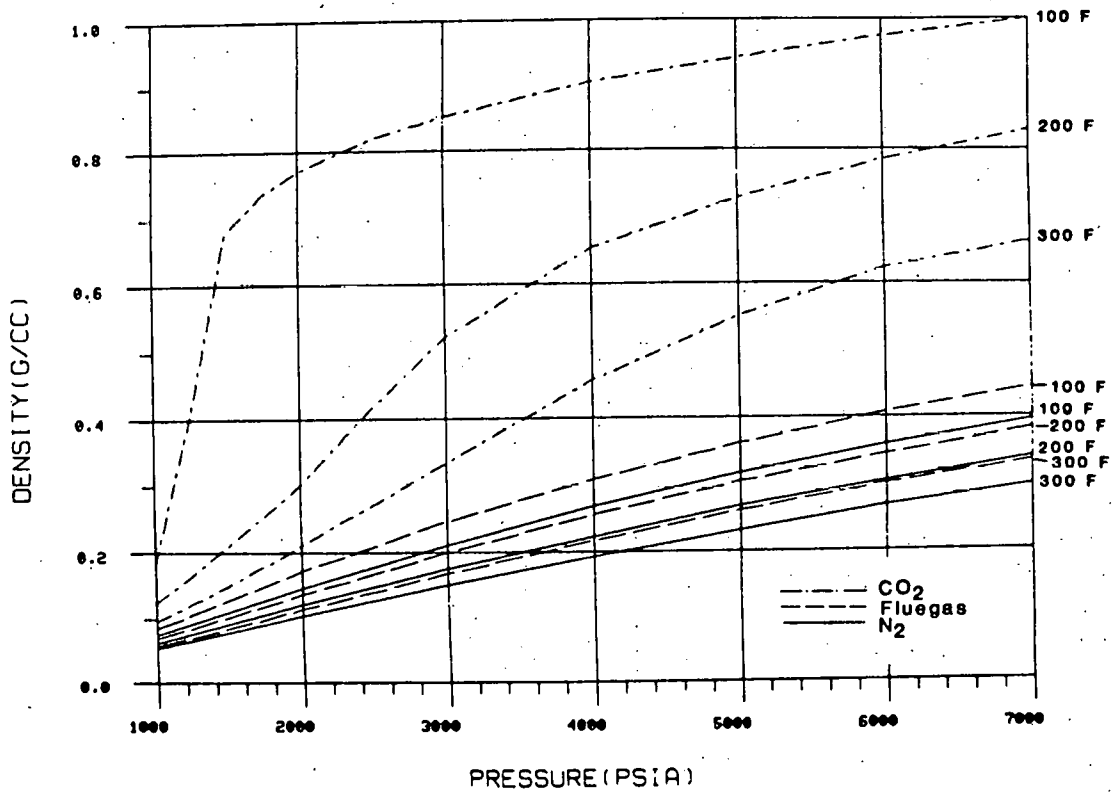

SI Metric Conversion Factors

psi x 6.894757 E - 03 = MPa

(°F - 32) 5/9 = °C

lb/ft<sup>3</sup> x 1.602 E - 02 = g/cc

Exhibit 2-1 Density of CO<sub>2</sub>, N<sub>2</sub>, and Flue Gas (87% N<sub>2</sub>, 13% CO<sub>2</sub>) with Varying Pressures and Temperatures.

Source: SAI In-house Data



2. Nitrogen has a compressibility factor that is three times that of  $\text{CO}_2$ . The compressibility factors for flue gas were calculated using a mixture of 87 percent  $\text{N}_2$  and 13 percent  $\text{CO}_2$ . A plot of the compressibility factor for  $\text{N}_2$ ,  $\text{CO}_2$ , and flue gas vs. pressure and temperature is shown in Exhibit 2-2. Nitrogen is shown to have a uniformly higher compressibility than that of  $\text{CO}_2$  and flue gas.

Nitrogen is relatively insoluble in water and brine. Pressure and salinity play a major role here while temperature, although a factor, is not as important. Carbon dioxide and natural gas are more soluble in water than is nitrogen (see Ref. 2-2, 2-5). This property is important for pressure maintenance operations.

Nitrogen is more soluble in high-gravity than low-gravity oils. The solubility of nitrogen in oil depends on the composition of the oil. Exhibit 2-3 shows the solubility of nitrogen in 20-40° API oils with a temperature range of 100 to 300°F (38 to 113°C) and a pressure range from 3000 to 8000 psig (20.7 to 55.2 MPa) (see Ref. 2-2).

The nitrogen gas formation volume factor shows that nitrogen has a uniformly increasing positive deviation from ideal gas behavior as pressure increases (Ref. 2-2). The gas formation volume factors for nitrogen,  $\text{CO}_2$  and flue gas (87 percent  $\text{N}_2$  and 13 percent  $\text{CO}_2$ ) vs. pressure and temperature are shown in Exhibit 2-4.

The viscosities of nitrogen and methane are of the same order of magnitude up to a pressure of approximately 6000 psi (41.4 MPa). This property is an asset in the gravity effect (density) in gas cap replacement. Pure nitrogen is also inert, noncombustible, completely dry, non-explosive, and non-toxic. Nitrogen has no corrosion problems associated with it while with carbon dioxide, flue gas and acid gas flooding, there are some corrosion problems. (see Ref. 2-2, 2-6, 2-7, 2-8, 2-9, 2-10).

When nitrogen is commingled with most other fluids, it remains in bubble form. This property is important for fluid lifting, and where nitrogen is being proposed as a drive gas after surfactant flooding (see Ref. 2-9, 2-11).

Nitrogen is a colorless, odorless gas, whereas flue gas is not. When flue gas containing sulfur compounds is dissolved in oil, the produced oil has a dark yellow color and the fluid containing  $\text{H}_2\text{S}$  has a bad odor associated with it (see Ref. 2-9).

Nitrogen liquid weight is 6.74 lb/gal (0.808 kg/l) at STP. One gallon (3.7854 l) of liquid nitrogen expands to 93.11 SCF (2.637  $\text{m}^3$ ) of gas at STP.

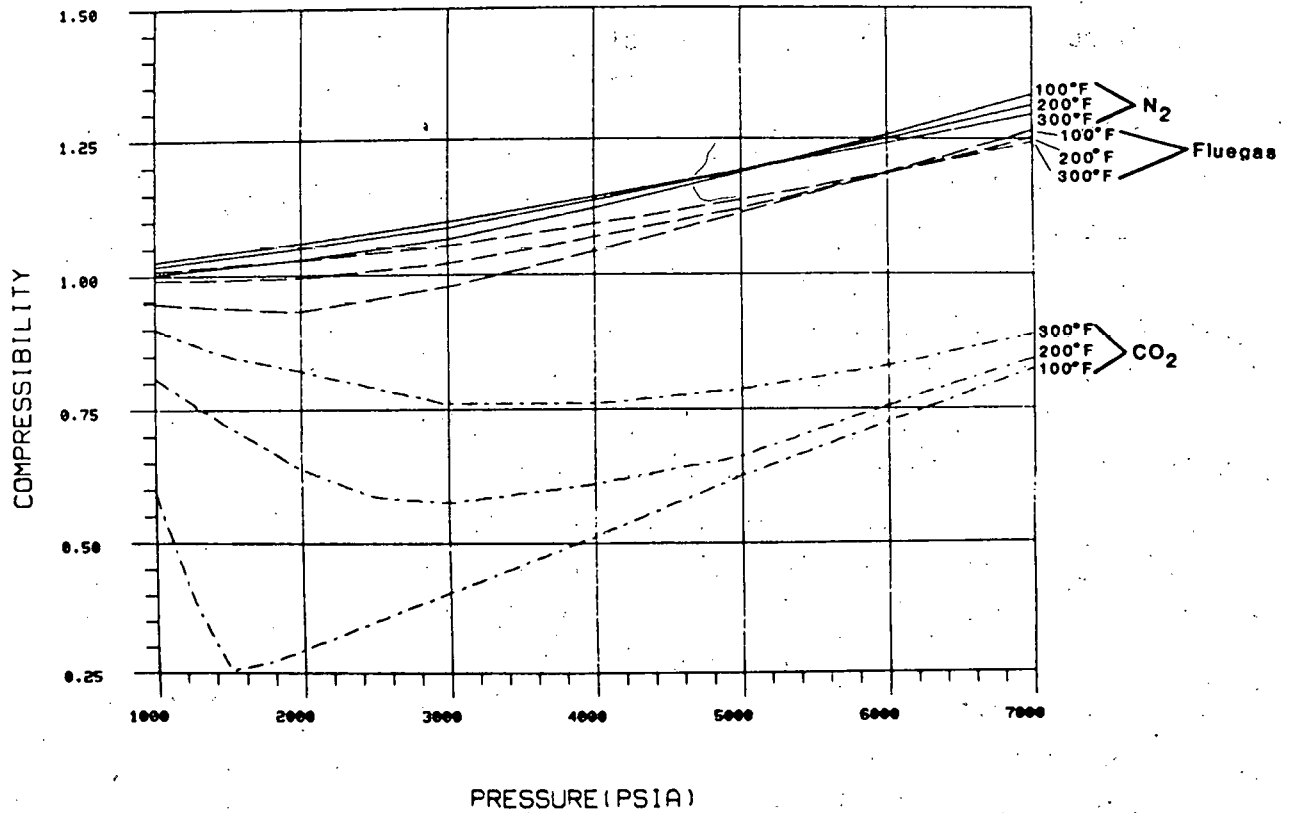

SI Metric Conversion Factors

psi x 6.894757 E - 03 = MPa

(°F - 32) 5/9 = °C

Exhibit 2-2 Compressibility of N<sub>2</sub>, CO<sub>2</sub>, and Flue Gas (87% N<sub>2</sub>, 13% CO<sub>2</sub>) with Varying Pressures and Temperatures

Source: SAI In-house Data

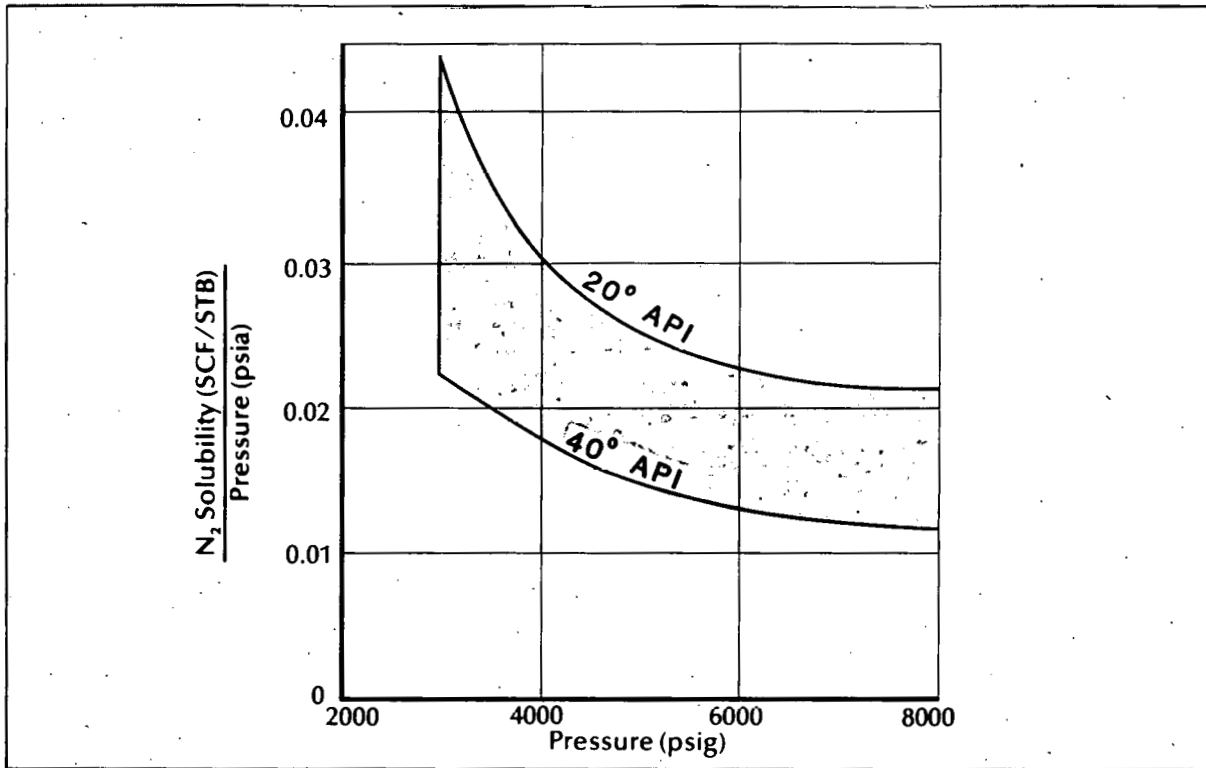

SI Metric Conversion Factors

psi x 6.894757 E - 03 = MPa

SCF/STB x 1.781 E - 01 = m<sup>3</sup>/m<sup>3</sup>

Exhibit 2-3 Nitrogen Solubility as a Function of Pressure

Source: Ref. 2-2

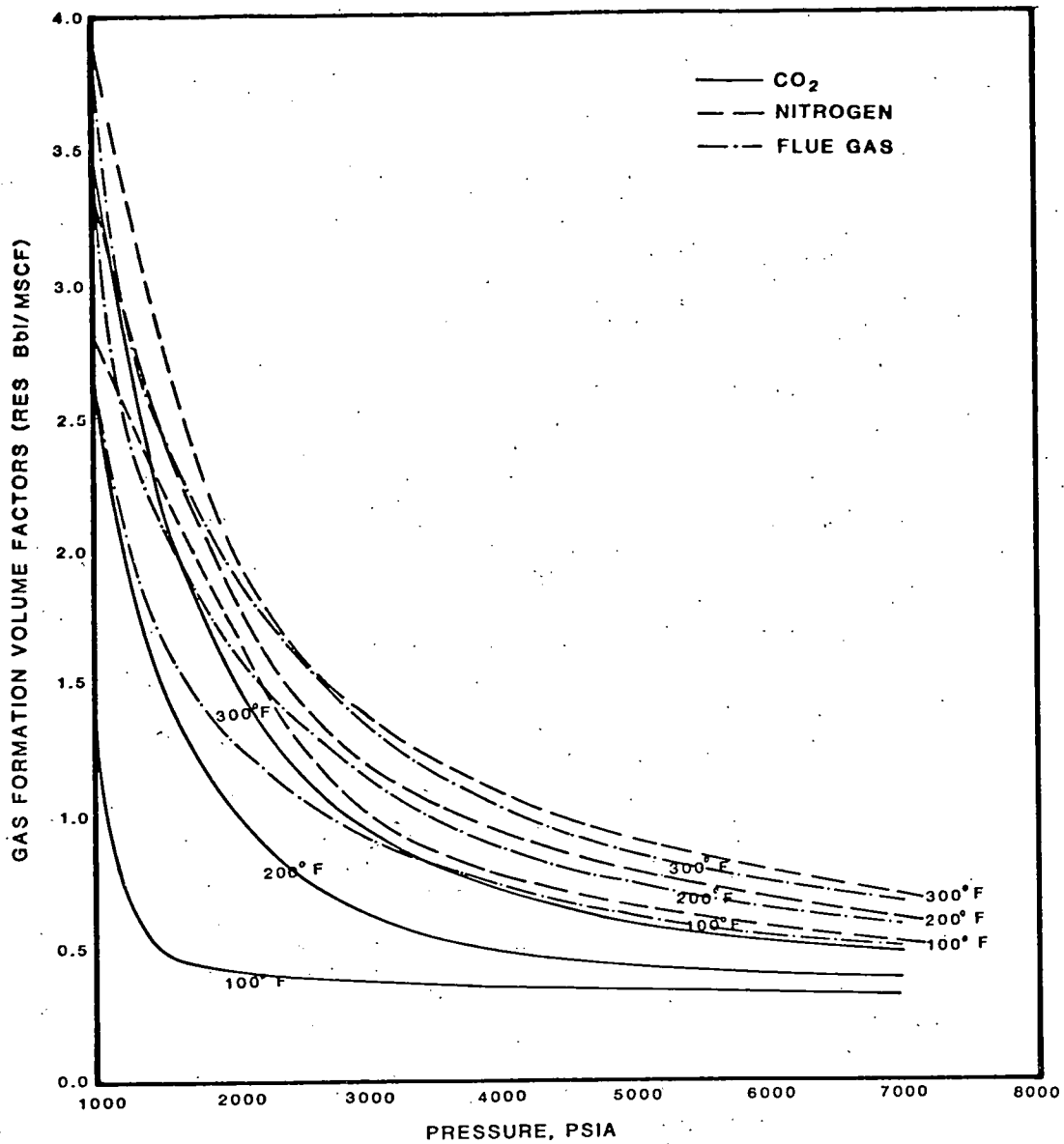

SI Metric Conversion Factors

psi x 6.894757 E - 03 = MPa

(°F - 32) 5/9 = °C

Res. bbl/MSCF x 5.615 E - 03 = m<sup>3</sup>/m<sup>3</sup>

Exhibit 2-4 Gas Formation Volume Factors for CO<sub>2</sub>, N<sub>2</sub> and Flue Gas (78% N<sub>2</sub>, 13% CO<sub>2</sub>) with Varying Pressures and Temperatures

Source: SAI In-house Data

Nitrogen is only miscible with oil at pressures above 5000 psi (34.47 MPa). The miscibility of nitrogen with oil is dependent on the API gravity of the oil: the lower the API gravity, the lower the miscibility pressure (see Ref. 2-7, 2-12).

The viscosity factor of nitrogen is favorable since it is of the same order of magnitude as that of gas cap gas (see Ref. 2-6).

1000 cubic feet ( $28.317 \text{ m}^3$ ) of nitrogen at 3000 psi (20.7 MPa) will occupy about the same reservoir space as one barrel ( $.159 \text{ m}^3$ ) of oil.

## 2.2 FLUE GAS

The properties of flue gas are dependent on the composition of its components.

The composition of flue gas (exhaust gas or inert gas) depends on its source. For example, 1000 cubic feet ( $28.32 \text{ m}^3$ ) of flue gas or inert gas produced from natural gas contains 883 cubic feet ( $.25 \text{ m}^3$ ) of nitrogen and 117 cubic feet ( $3.26 \text{ m}^3$ ) of carbon dioxide; whereas 1000 cubic feet ( $28.32 \text{ m}^3$ ) of flue gas or inert gas produced from propane contains 863 cubic feet ( $24.48 \text{ m}^3$ ) of nitrogen and 137 cubic feet ( $3.88 \text{ m}^3$ ) of carbon dioxide (see Ref. 2-14, 2-15, 2-16)

The average composition of flue gas used in Block 31 Field in Texas was 87 mol percent nitrogen, 12 mol percent carbon dioxide and 1 mol percent carbon monoxide. At Block 31 Field, flue gas is produced from residue gas. One cubic foot ( $.028 \text{ m}^3$ ) of residue gas will make 9 to 11 cubic feet ( $.25$  to  $.31 \text{ m}^3$ ) of flue gas. The combustion of 114 cubic feet ( $3.23 \text{ m}^3$ ) of natural gas or 45 cubic feet ( $1.27 \text{ m}^3$ ) of propane will produce 1000 feet ( $28.32 \text{ m}^3$ ) of inert gas (see Ref. 2-14, 2-15, 2-16).

Flue gas has a higher formation volume factor than natural gas or carbon dioxide. Flue gas occupies about 1.2 times the reservoir volume that would be occupied by natural gas (methane) at pressures of 2500 to 4000 psi (17.23 to 27.58 MPa) and a temperature of  $150^\circ\text{F}$  ( $65.6^\circ\text{C}$ ). This ratio will depend on the composition of the flue gas (see Ref. 2-17).

Flue gas is miscible with crude oil at relatively higher pressures than natural gas or carbon dioxide. The miscibility of flue gas in oil depends on the composition of both the flue gas and the oil. Viscosity reductions are greatest with heavy crude oils.

The properties of flue gas lie between the properties of  $N_2$  and  $CO_2$  depending on its composition. Many of these properties can be calculated (see Exhibits 2-1, 2-2, and 2-4) using empirical equations and the properties of its components (see Ref. 2-19).

### References

- 2-1 Yaws, Carl, L. H. S. N. Setty, J. R. Hopper, and V. Luna, "Physical and Thermodynamic Properties, Part 8, Major Diatomic gases -  $H_2$ ,  $N_2$ ,  $O_2$ ....," Chemical Engineering, V. 82, No. 2, January 20, 1975, p. 99-106.
- 2-2 Anonymous, "Physical Properties of Nitrogen for Use in Petroleum Reservoirs", Air Products and Chemicals, Inc., A Company Brochure, September 1977, p. 1-17.
- 2-3 Considine, Douglas M., Chemical Process and Technology Encyclopedia, McGraw Hill Book Company, 1974, p. 772.
- 2-4 O'Leary, T. P., T. H. Murray, T. Guillary, P. Griere, M. C. Reece, M. Nugent, and T. Perkins, "Nitrogen Driven  $CO_2$  Slugs reduces Costs," Petroleum Engineer International, May 1979, p. 130-140.
- 2-5 Ott, William K., and E. H. Gras, "Effect on Stimulation Fluid Density and Volume," Oil and Gas Journal, V. 77, No. 10, March 5, 1979, p. 72-75.
- 2-6 Calvin, James W., and John L. Voge, "An Evaluation of Nitrogen Injection as a Method of Increasing Gas Cap Reserves and Accelerating Depletion, Ryckman Creek Field Uinta County, Wyoming," SPE 8384, 54th Annual Fall Technical Conference and Exhibition, SPE/AIME, September 1979.
- 2-7 Peterson, Arthur V. "Optimal Recovery Experiments with  $N_2$  and  $CO_2$ ," Petroleum Engineer International, November 1978, p. 40-50.
- 2-8 Anonymous, "Pure Nitrogen Can Make You Money", Air Products and Chemicals, Inc., A Company Brochure, 1977, p. 1-8.
- 2-9 Ott, William K., and E. H. Gras, "Flow Back, Commingled  $N_2$  Fluid Curves Air Planning," Oil and Gas Journal, V. 77, No. 9, February 26, 1979, p. 103-106.
- 2-10 Wilson, Keith, "Enhanced Recovery Inert Gas Processes Compared," Oil and Gas Journal, V. 76, No. 31, July 1978, p. 168.
- 2-11 Ferrell, Howard H., and Robert T. Mathews, "In situ Preparation of Surface Active Agents in Subterranean Formations," US Patent No. 3,392,782, July 10, 1968.
- 2-12 Rushing, M. D., B. C. Thomasson, B. Reynolds, and P. B. Crawford, "Miscible Displacement with Nitrogen," Petroleum Engineer, November 1977, p. 26-30.

- 2-13 Anonymous, "Use Low Cost Nitrogen, Manufactured on Site, as Substitute Gas for Injection to Increase Recovery," Oil and Gas Cryogenics, Inc., Houston, TX.
- 2-14 Hardy, Jay H., and Nelson Robertson, "Miscible Displacement by High-Pressure Gas at Block 31," Petroleum Engineer, November 1975, p. 24-48.
- 2-15 Clark, Norman, Jr., Thomas G. Roberts, et al., "Engine Exhaust Gas Boosts Heavy Oil Recovery," Petroleum Engineer, August 1964, p. 43-47.
- 2-16 Davidson, K., "Inert Gas Generators Stimulates Viscous Oil Flow," Petroleum Equipment, March-April 1966, p. 6-8.
- 2-17 Herbeck, E. F., R. C. Heintz, and J. R. Hastings, "Fundamental of Tertiary Oil Recovery," Petroleum Engineer, April 1976, p. 66-71.
- 2-18 Davidson, K. "Inert Gas Boosts Recovery from Heavy Oil Reservoirs," World Oil, March 1967, p. 98-105.
- 2-19 Liley, Peter E., and W. R. Gamble, "Physical and Chemical Data," Section 3, Chemical Engineers Handbook, edited by Robert H. Perry and C. H. Chilton, McGraw Hill, New York, 1973.

### 3. APPLIED RESEARCH ACTIVITIES

This section covers a state-of-the-art review of literature related to conceptual process development and laboratory experimental work performed by researchers in EOR using nitrogen, flue gas, and other gases (excluding carbon dioxide and hydrocarbon gases) including:

- Nitrogen injection (includes pure nitrogen and in combinations with other gases or techniques).
- Flue gas (exhaust gas, acid gas, inert gas) which generally consists of CO<sub>2</sub>, nitrogen, and other impurities.
- Other gases which include air and SO<sub>2</sub> injection.

#### 3.1 NITROGEN INJECTION

Nitrogen has been proposed and used for pressure maintenance, to prevent retrograde condensation, and as a miscible displacement agent in enhanced oil and gas recovery.

##### 3.1.1 MISCIBLE DISPLACEMENT USING NITROGEN

There have been several laboratory scale experiments with the purpose of recovering oil using nitrogen as a miscible gas. The details of these experiments are discussed in References 3-1 through 3-4, and results are summarized below.

Laboratory tests have shown that nitrogen injection at higher pressures have miscibly displaced light crudes resulting in oil recoveries of 90 percent in a 40 foot (12.2 m) sand pack (Ref. 3-1, 3-2). This compares favorably with laboratory test recoveries by miscible displacement with high-pressure natural gas. Oil recoveries using nitrogen are believed to be due to the extraction vaporization of light- and intermediate-hydrocarbons from oil. After injection, pure, high pressure nitrogen will become sufficiently enriched with light- and intermediate-hydrocarbons for miscibility to occur. Thus, light ends and intermediates are very important for miscible displacement using nitrogen. Laboratory tests show that heavy crudes are not good candidates for miscible displacement using nitrogen. Crude oils of 35° API gravity and higher are prospects for miscible displacement by high-pressure nitrogen injection. Laboratory tests using a 54.4° API gravity oil with a gas oil



ratio (GOR) of 700 SCF/bbl ( $\approx 125 \text{ m}^3/\text{m}^3$ ) in a 40 foot (12.2 m) sand pack showed that oil recovery increases with increased injection pressure. At 2500 psi (17.24 MPa) and 250°F (121°C), recovery was 61 percent. At 3000 psi (20.68 MPa), recovery was 70 percent for temperatures of 72 to 250°F (22.2 to 121°C). At 4000 psi (27.58 MPa), recovery was 78 percent at 72°F (22.2°C) and was 85 percent at 250°F (121°C). At 5000 psi (34.47 MPa), recoveries ranged from 85 to 72 percent as temperatures ranged from 72 to 250°F (22.2°C to 121°C). Exhibit 3-1 shows the effect of pressure on oil recovery using high pressure nitrogen at various temperatures and Exhibit 3-2 shows the effect of temperature on oil recovery using high pressure nitrogen at various pressures. These plots show that the oil recovery percentage increases with an increase in pressure. Exhibit 3-2 shows that recovery is independent of temperature up to 3000 psi (20.68 MPa), but increases with temperature at 4000 and 5000 psi (27.58 MPa and 34.47 MPa).

Another set of laboratory experiments using oil in a slim tube from Painter Reservoir Field showed that a nitrogen injection system has a greater than 90 percent recovery potential, in addition to an economic advantage over CO<sub>2</sub> (Ref. 3-3). The results suggested that a nitrogen-based recovery program offers a density-gravity advantage that would accelerate the simultaneous production of Painter Reservoir oil and its gas-cap. Information on reservoir characteristics of the Painter Reservoir and planned field activities are described in Section 4.

Slim tube experiments were performed using Painter Reservoir Oil to determine miscibility pressures with the multiple contact of reservoir fluids and injection gases (nitrogen and CO<sub>2</sub>). The results of these experiments are depicted in Exhibits 3-3, 3-4, and 3-5.

The first set of experiments used condensate fluid with nitrogen as the displacing medium at 4180 psi (28.82 MPa). Fluid recovery was 99 percent. The second system used Painter Reservoir oil with nitrogen as the displacing medium at 4280 psi (29.51 MPa). Recovery was 91 percent. This indicates that N<sub>2</sub> miscibility in oil is dependent on oil composition. The miscibility pressure is lower and oil recovery is higher for oil containing a higher percentage of light crude. Exhibit 3-5 suggests that 4280 psi (29.51 MPa) is about the minimum reservoir pressure at which miscibility of Painter Reservoir oil with nitrogen could be generated. In the third system using Painter Reservoir oil, CO<sub>2</sub> was injected at 4300 psi (29.65 MPa) and recovery was 100 percent.

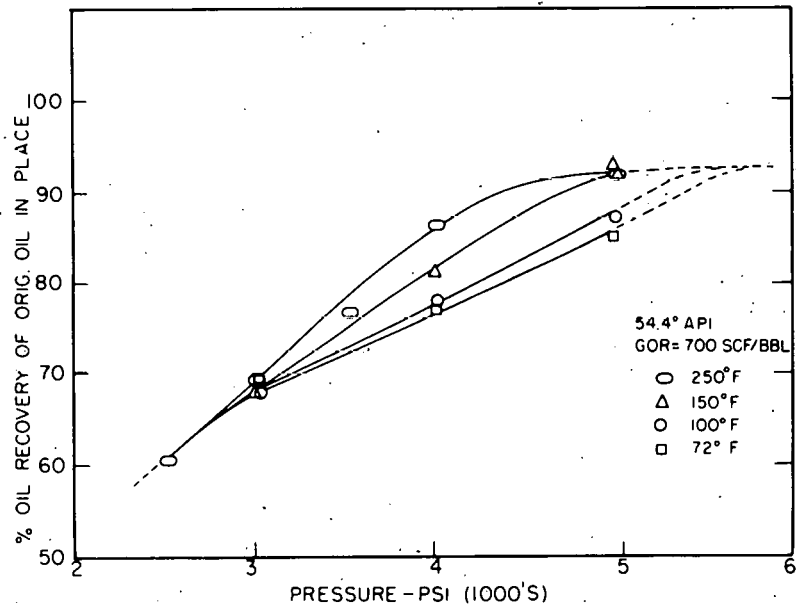

SI Metric Conversion Factors

psi x 6.894757 E - 03 = MPa

(°F - 32) 5/9 = °C

SCF/bbl x 1.781 E - 01 = m<sup>3</sup>/m<sup>3</sup>

Exhibit 3-1 Effect of Pressure on Oil Recovery  
Using High-Pressure Nitrogen Injection

Source: Ref. 3-1

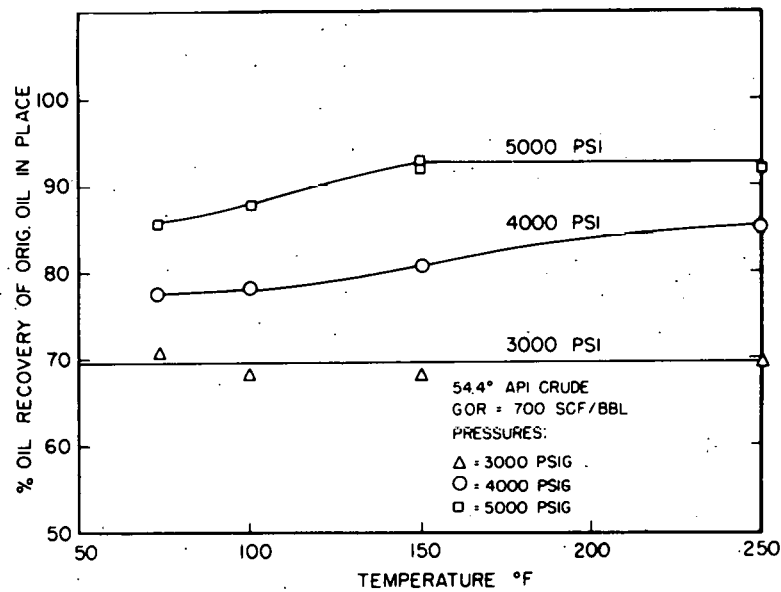

SI Metric Conversion Factors

psi x 6.894757 E - 03 = MPa

(°F - 32) 5/9 = °C

SCF/bbl x 1.781 E - 01 = m<sup>3</sup>/m<sup>3</sup>

Exhibit 3-2 Effect of Temperature on Oil Recovery Using High-Pressure Nitrogen Injection

Source: Ref. 3-1

Experiment Number	Fluids Used	Pressure		Percent Recovery of OOIP at 1.2 Pore Volume Injection
		psia	MPa	
1	Condensate Fluid-nitrogen	4180	28.82	99
2	Black oil Nitrogen	4280	29.51	91
3	Black oil CO <sub>2</sub>	4300	29.65	100

Condensate Fluid Composition at 164°F (73.33°C) and 4000 psia (2.76 MPa)

Painter Reservoir Oil (Black Oil) Composition at 164°F (73.33°C) and 3990 psia (2.75 MPa)

Component	Mole Fraction	Component	Mole Fraction
N <sub>2</sub>	0.0170	N <sub>2</sub>	0.0102
CO <sub>2</sub>	0.0050	CO <sub>2</sub>	0.0040
C <sub>1</sub>	0.6970	C <sub>1</sub>	0.5462
C <sub>2</sub>	0.1092	C <sub>2</sub>	0.1147
C <sub>3</sub>	0.0604	C <sub>3</sub>	0.0733
C <sub>4</sub>	0.0327	C <sub>4</sub>	0.0401
C <sub>5</sub>	0.0141	C <sub>5</sub>	0.0196
C <sub>6</sub>	0.0089	C <sub>6</sub>	0.0142
C <sub>7</sub>	0.0109	C <sub>7</sub>	0.0221
C <sub>8</sub>	0.0143	C <sub>8</sub>	0.0423
C <sub>9</sub>	0.0079	C <sub>9</sub>	0.0191
C <sub>10</sub>	0.0054	C <sub>10</sub>	0.0113
C <sub>11</sub>	0.0040	C <sub>11</sub>	0.0081
C <sub>12</sub>	0.0026	C <sub>12</sub>	0.0078
C <sub>13</sub>	0.0023	C <sub>13</sub>	0.0064
C <sub>14</sub>	0.0016	C <sub>14</sub>	0.0071
C <sub>15</sub>	0.0018	C <sub>15</sub>	0.0535
C <sub>16</sub>	0.0011	C <sub>16</sub>	
C <sub>17+</sub>	0.0038	C <sub>17+</sub>	
Total	1.0000	Total	1.0000

Exhibit 3-3 Slim Tube Experiments on Painter Reservoir Oil Using Nitrogen and Carbon Dioxide

Source: Ref. 3-3

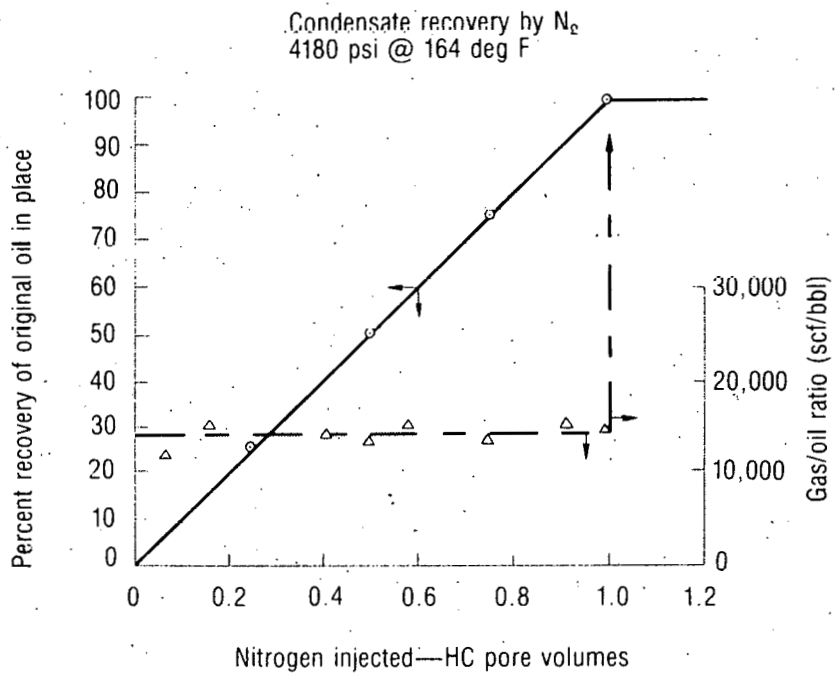

SI Metric Conversion Factors

psi x 6.894757 E - 03 = MPa

(°F - 32) 5/9 = °C

SCF/bbl x 1.781 E - 01 = m<sup>3</sup>/m<sup>3</sup>

Exhibit 3-4 Condensate Slim Tube Recovery by N<sub>2</sub>

Source: Ref. 3-3

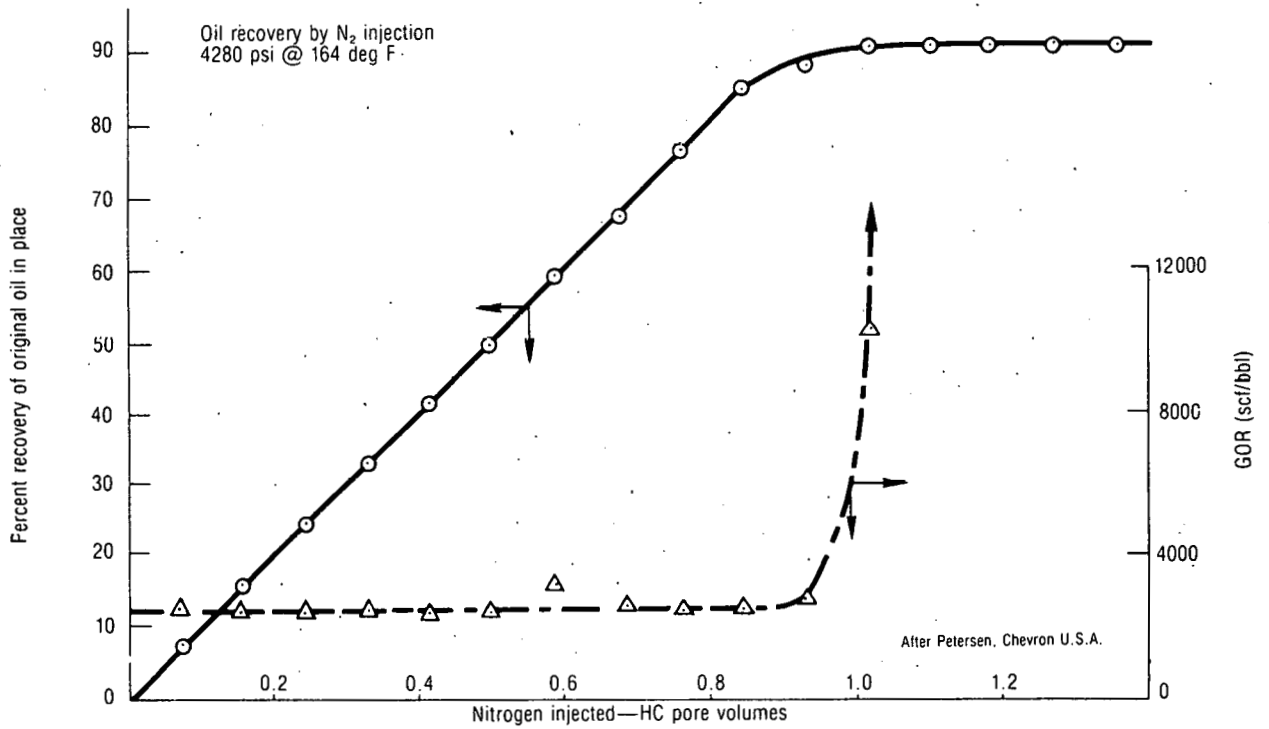

### SI Conversion Factors

$$\text{psi} \times 6.894757 \text{ E} - 03 = \text{MPa}$$

$$\text{SCF/bbl} \times 1.781 \text{ E} - 01 = \text{m}^3/\text{m}^3$$

Exhibit 3-5 Slim Tube Experiments with N<sub>2</sub> Using Painter Reservoir Black Oil

Source: Ref. 3-3

These laboratory data show that  $\text{CO}_2$  is a better displacing medium than nitrogen. However,  $\text{N}_2$  is cheaper to generate and transport than  $\text{CO}_2$ . The use of  $\text{CO}_2$  also necessitates corrosion control (see Sections 5 and 6).

In another set of experiments (Ref. 3-4) nitrogen and  $\text{CO}_2$  were injected at  $105^\circ\text{F}$  ( $40.55^\circ\text{C}$ ) using Leveland crude oil in a 40 foot (12.2 m) unconsolidated sand pack. There was no solution gas in the crude oil. The results are shown in Exhibit 3-6. At nitrogen pressures of 1,200 psi (8.27 MPa) and 1,850 psi (12.75 MPa), recovery was near 62 percent of the stock-tank oil originally in place. When  $\text{CO}_2$  was used at 1200 psi (8.27 MPa), oil recovery was 86 percent. At 1,350 psi (9.30 MPa), the recovery was greater than 90 percent. This shows that at low pressure ranges nitrogen is not miscible whereas  $\text{CO}_2$  is miscible and suggests that light ends and intermediates in crude oil are very important for  $\text{N}_2$  miscibility. This is not true for  $\text{CO}_2$ .

When using nitrogen, stock-tank oil must be recombined with the wet, separator gas to determine the miscibility pressure. Nitrogen drives may recover less than 70 percent of the dead stock-tank crude oil (no gas in solution). However, nitrogen drives may recover over 95 percent for light crude oils at high temperatures when wet gas is added to the stock tank oil. Nitrogen drives will pick up intermediates; this induces miscibility. Thus, the miscibility obtained using  $\text{N}_2$  is generally multiple-contact miscibility and is due to the vapor extraction of light and intermediate ends of crude oil. This suggests that nitrogen will be more suited to the recovery of light oils.

In another set of tests (see Ref. 3-4), oil recovery was through the injection of  $\text{CO}_2$  slugs of various, hydrocarbon pore-volume sizes pushed by nitrogen. Exhibit 3-7 shows a plot of percent oil recovery vs  $\text{CO}_2$  slug size pushed by nitrogen for the Wasson Crude Oil which contained no solution gas. The results showed that when using 5 to 10 percent (hydrocarbon pore-volume) slugs of  $\text{CO}_2$  followed by  $\text{N}_2$ , recovery was 90 to 96 percent of the oil originally in place. After injection of slugs of  $\text{CO}_2$  equal to approximately 24 percent of the hydrocarbon pore volume, the oil recovery was approximately 98 percent.

Using  $\text{CO}_2$  slugs rather than pure  $\text{CO}_2$  in a tertiary recovery run could permit a stretching of  $\text{CO}_2$  supplies and a reduction in cost. Because nitrogen costs about one-half that of  $\text{CO}_2$  per MCF, and because the compressibility

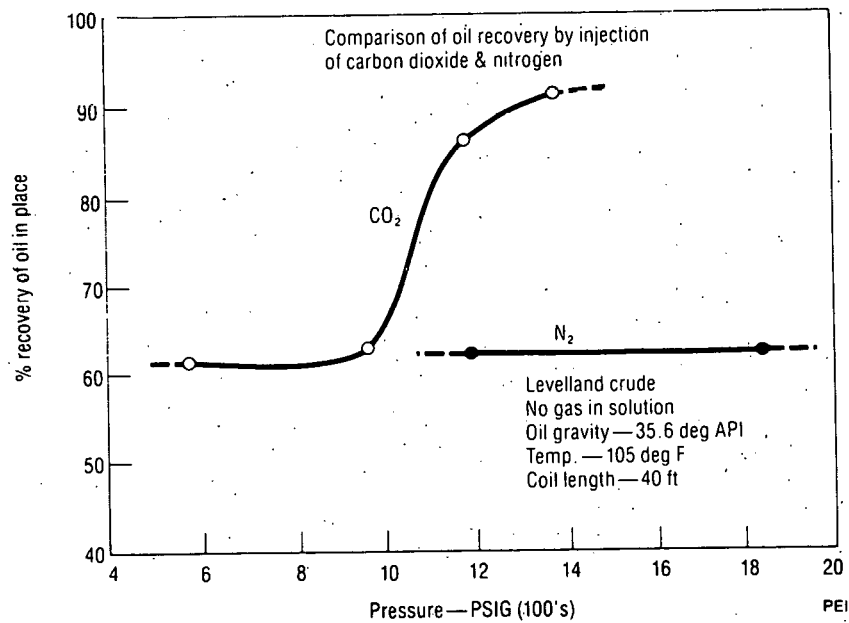

SI Metric Conversion Factors

psi x 6.894757 E - 03 = MPa

ft x 3.048 E - 01 = m

Exhibit 3-6 A Comparison of Oil Recovery by Injection of Carbon Dioxide and Nitrogen Using Crude Containing No Solution Gas

Source: Ref. 3-4



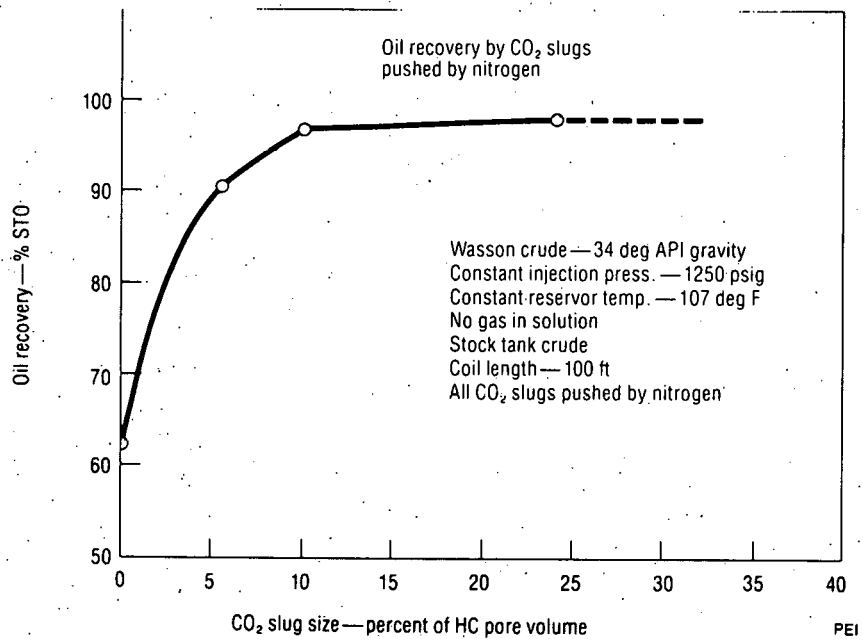

\*Stock Tank Oil

SI Metric Conversion Factors

psi x 6.894757 E - 03 = MPa

(°F - 32) 5/9 = °C

ft x 3.048 E - 01 = m

Exhibit 3-7 Oil Recovery by CO<sub>2</sub> Slugs Pushed by Nitrogen for the Wasson Crude

Source: Ref. 3-4

factor of nitrogen is three times that of  $\text{CO}_2$  under West Texas reservoir conditions, the cost of nitrogen per barrel of reservoir pore-space may be only 15 percent that of  $\text{CO}_2$ .

### Conclusions

The miscible displacement of oil by nitrogen is primarily due to the extraction vaporization process; that by  $\text{CO}_2$  is due to both extraction vaporization and condensation processes. The pressures required for the miscibility of nitrogen are over 4000 psi (27.58 MPa) and are dependent on the hydrocarbon components of the oil. Light oil reservoirs having some solution gas would be good candidates for  $\text{N}_2$  flooding. Miscible displacement using nitrogen alone is not feasible for oil having little or no solution gas present. However, nitrogen flooding after an injection of a predetermined size of  $\text{CO}_2$  slug appears to be a good process for reservoirs having low amounts of solution gas. However, further experimentation and evaluations are needed to confirm this theory. The source of nitrogen (air) is inexhaustible, and  $\text{N}_2$  is cheaper (\$/MCF) than  $\text{CO}_2$ . Therefore, the low production cost and its noncorrosive nature will favor its utilization for EOR.

#### 3.1.2 $\text{N}_2$ INJECTION FOR PRESSURE MAINTENANCE AND TO PREVENT RETROGRADE CONDENSATION (Ref. 3-5, 3-6, 3-7)

Pressure maintenance is generally required for gas condensate reservoirs in order to prevent or minimize retrograde liquid loss. It is also needed for volatile oil and in black oil reservoirs in order to improve recovery. Lean natural gas has been successfully used for many years as an injection fluid in condensate reservoir cycling, but its limited availability and increasing cost have made it economically unattractive.

Nitrogen has been considered for pressure maintenance operations because it can be produced by air separation plants more cheaply than natural gas. The possibility that significant changes in phase equilibria could occur in reservoir fluids upon the injection of nitrogen had hindered its acceptance and for as an injection gas. However, recent promising field-test results have helped it to become accepted as a better alternative (see Section 4, Use of Nitrogen Injection in Fordoche and other fields).

Experimental laboratory tests were conducted by Amoco Production Co. with several different reservoir fluids to determine the effects of contact by varying amounts of nitrogen (Ref. 3-6). Three gas condensate fluids and one

black oil were tested, and their properties are given in Exhibit 3-8. The gas liquid ratios for these fluids ranged from about 1.77 MSCF/bbl (315 "standard"  $m^3/m^3$ ) for the reservoir oil to 28 MSCF/bbl (about 4970 "standard"  $m^3/m^3$ ) for the leanest gas condensate.

It was concluded from these experiments that the injection of nitrogen into a gas-condensate, reservoir fluid will significantly increase the dew-point pressure and may cause retrograde liquid condensation where the nitrogen mixes with reservoir gas. Additional contact by nitrogen will revaporize a significant amount of the condensed retrograde liquid.

It was also concluded that contacting a black oil with nitrogen will strip the oil of its light and intermediate components. The effect is to decrease the oil formation volume factor and to increase the oil viscosity and density, but not to extreme limits. Exhibit 3-9 provides experimental evidence that contact by extreme amounts of nitrogen changes the oil properties to a reasonably expected degree (by stripping), but a heavy tar-like material does not result.

The Redlich-Kwong equation-of-state can be used to predict reliably the effects of nitrogen on phase equilibria and physical properties of reservoir fluids. The equation can be used in reservoir simulators to predict the overall effects of nitrogen injection on reservoir performance. A comparison of experimental results and those calculated using the Redlich-Kwong equation-of-state is presented in Exhibit 3-10.

Another set of experiments conducted earlier by Core Laboratories and Air Products and Chemicals (Ref. 3-5) provided similar results. Computer calculations indicated that mixing lean, natural gas with condensate reservoir fluid raised the dew point somewhat and caused some retrograde condensation. A much more significant effect was observed when nitrogen was mixed with the condensate. A retrograde-condensate reservoir fluid was chosen for laboratory experiments and its properties are shown in Exhibit 3-11.

The studies indicated that normal pressure depletion would result in recovery of 22.3 percent of the stock-tank liquid and 81.5 percent of the primary and second stage separator gases at an abandonment pressure of 700 psig (4.93 MPa). Retrograde loss would reach a maximum of 20 percent of the hydrocarbon pore volume at 2300 psig (15.96 MPa) as shown in Exhibit 3-12.

Experiments were conducted comparing the dew point and retrograde behavior of a lean gas (composition as shown in Exhibit 3-11) versus pure nitrogen. A

Composition (mol %)

<u>Component</u>	<u>Gas 1</u>	<u>Gas 2</u>	<u>Gas 3</u>	<u>Gas 4</u>
Nitrogen	0.20	0.23	2.20	0.65
Methane	67.50	73.15	74.17	45.02
Carbon Dioxide	2.01	2.12	0.06	0.02
Ethane	9.31	9.39	11.27	12.45
Hydrogen Sulfide	0.00	0.00	0.00	0.00
Propane	5.41	4.86	5.75	8.93
i-Butane	1.32	1.02	1.34	2.62
n-Butane	2.21	1.78	1.64	3.41
i-Pentane	0.80	0.60	0.40	1.63
n-Pentane	0.68	0.49	0.59	1.39
Hexanes	1.51	0.93	0.58	1.44
Heptanes Plus (C <sub>7</sub> +) <u>9.05</u>	<u>9.05</u>	<u>5.43</u>	<u>2.00</u>	<u>22.44</u>
Total	100.00	100.00	100.00	100.00

Properties of C<sub>7</sub>+

Molar Mass, lb/mole/ (kg/mole)	357/ (162)	357/ (162)	256/ (116)	406/ (184)
Density at 60 <sup>o</sup> F(288.7 K) lbs/ft <sup>3</sup> /(kg/m <sup>3</sup> )	44.67/ (795.7)	49.67/ (795.7)	46.31/ (741.9)	50.61/ (810.8)
Nominal Prod. Sep. GOR MSCF/bbl/ ("Standard" m <sup>3</sup> /m <sup>3</sup> )	4.73/ (843)	8.98/ (1600)	28/ (4970)	1.77/ (315)
Reservoir Temp. <sup>o</sup> F/ (K)	226/ (381)	226/ (381)	140/ (333)	140/ (333)
Dew Point Psi/ (MPa)	4453/ (30.7)	5207/ (35.9)	3002/ (20.7)	
Bubble Point Psi/ (MPa)				3002/ (30.7)

Exhibit 3-8 Compositions and Properties of Reservoir Fluids

Source: Ref. 3-6

Test Temp		Before Contact with Added N <sub>2</sub>	After Contact by 20 Pore Volume N <sub>2</sub> at 3000 psi (20.7 MPa) & 333 K		
		<u>Density at 1 atm (0.10 MPa)</u>			
°F	K	lb/ft <sup>3</sup>	kg/m <sup>3</sup>	lb/ft <sup>3</sup>	kg/m <sup>3</sup>
60	288.7	49.45	792.2	50.69	812.1
80	299.8	48.93	783.8	50.19	804.0
100	310.9	48.39	775.5	49.73	796.7
120	322.0	47.91	767.5	49.26	789.1
140	333.2	47.38	759.1	48.79	781.7

		<u>Viscosity (cp) at 1 atm. (0.10 MPa)</u>			
°F	K	cp	MPa.S	cp	MPa.S
80	299.8	1.6	1.6	2.6	2.6
100	310.9	1.4	1.4	2.1	2.1
120	322.0	1.2	1.2	1.7	1.7
140	333.2	1.0	1.0	1.4	1.4

Exhibit 3-9 Effect of Nitrogen Contact on Oil Properties

Source: Ref. 3-6

Cumulative Pore Volumes (PV) of Nitrogen Contacted at 3000 psi (20.7 MPa) & 140°F (333 K)

Component	No N <sub>2</sub>	0.14 PV N <sub>2</sub>		0.50 PV N <sub>2</sub>		1.0 PV	1.5 PV N <sub>2</sub>	
	Oil 1	Calcd	Exptl	Calcd	Exptl	Calcd	Calcd	Exptl
Nitrogen	0.65	6.60	5.40	13.70	13.31	18.06	19.86	21.95
Methane	45.02	33.10	35.97	17.42	15.68	7.04	2.58	2.60
Carbon Dioxide	0.02	0.02	0.00	0.02	0.00	0.01	0.01	0.00
Ethane	12.45	11.44	11.81	9.22	9.81	6.41	4.17	2.50
Propane	8.93	9.20	9.12	9.20	9.52	8.39	7.19	3.87
i-Butane	2.62	2.81	2.79	3.04	3.20	3.05	2.88	1.59
n-Butane	3.41	3.76	3.71	4.23	4.47	4.44	4.30	2.42
i-Pentane	1.63	1.85	1.83	2.19	2.41	2.43	2.51	1.59
n-Pentane	1.39	1.59	1.58	1.92	2.14	2.19	2.32	1.48
Hexanes	1.44	1.71	1.32	2.15	1.87	2.55	2.79	1.83
Heptanes Plus (C <sub>7</sub> +) )	22.44	27.92	26.47	36.91	37.59	45.43	51.33	60.19
TOTAL:	100.00	100.00	100.00	100.00	100.00	100.00	100.00	100.00

Exhibit 3-10 Effect of Nitrogen Contact on Oil Composition (Mol %)

Source: Ref. 3-6

### Reservoir Fluid Composition

<u>Component</u>	<u>Mole Percent</u>
Hydrogen Sulfide	Nil
Carbon Dioxide	1.21
Nitrogen	1.94
Methane	65.99
Ethane	8.69
Propane	5.91
iso-Butane	2.39
normal-Butane	2.78
iso-Pentane	1.57
normal-Pentane	1.12
Hexanes	1.81
Heptanes plus	<u>6.59</u>
	100.00
Dew point	3418 psig (23.64 MPa)
Reservoir temperature	200°F (93.3°C)
Stock tank liquid gravity	61.6°API
Gas/liquid ratio	4812 SCF/Separator Barrel (857 m <sup>3</sup> /m <sup>3</sup> )

Exhibit 3-11 Reservoir Fluid Composition

Source: Ref. 3-5

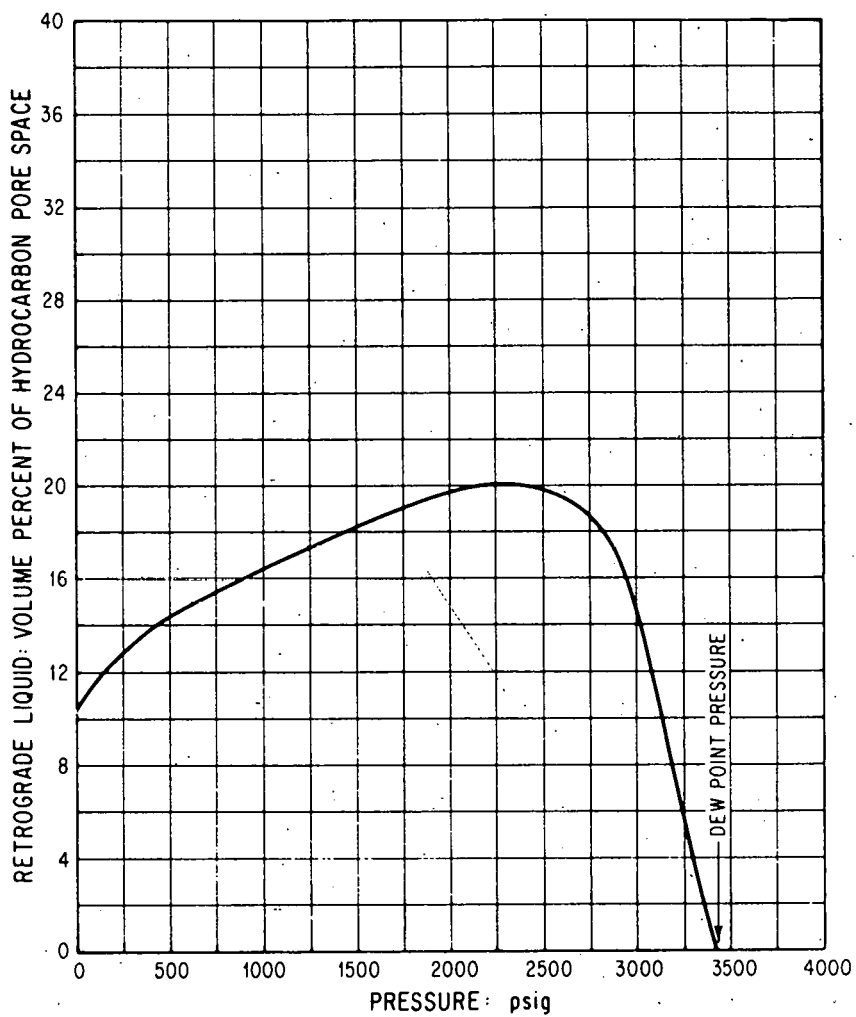

SI Metric Conversion Factors

psi x 6.894757 E - 03 = MPa

Exhibit 3-12 Retrograde Condensation During Depletion at 200<sup>0</sup>F (93.3<sup>0</sup>C)

Source: Ref. 3-5



total of 2467 SCF of lean gas per barrel of original reservoir fluid ( $440 \text{ m}^3$  of lean gas per  $\text{m}^3$  of reservoir fluid) was added, increasing the dew point from 3428 to 4880 psig (23.73 MPa to 33.74 MPa). A total of 940 cubic feet of nitrogen was injected per barrel ( $167.4 \text{ m}^3$  nitrogen per  $\text{m}^3$  of oil), increasing the dew point to 7100 psig (49.04 MPa). The results are depicted in Exhibit 3-13. The dew point pressure elevation with nitrogen mixtures was much greater than with lean gas mixtures.

Equilibrium mixing tests, of the displacing phase with the reservoir fluid at the displacing front, indicate that the dew point of the mixture will increase and that retrograde loss will occur if the reservoir pressure is near the original dew point pressure. If the injection gas is nitrogen, the retrograde loss will be much greater.

Laboratory sand-tube experiments clearly demonstrated that little mixing occurs during gas/gas-displacement. Retrograde drop-out will only result in liquid loss if it occurs as a result of mixing in the reservoir. Although mixing in the production wells may cause condensation, the liquid will be recovered. The results also suggest that mixing within the reservoir can be affected by the following factors: mobility ratio, molecular diffusion and intergranular dispersions, pore size distribution, changes in flow pattern, and changes in reservoir pressure.

An economic evaluation of cyclic gas-condensate with nitrogen was conducted by Donohoe, et al., (Ref. 3-7). The effects of different reservoir fluid compositions and the degrees of reservoir heterogeneity upon the economic potential of this depletion mechanism were considered. The performance projections were made for a hypothetical reservoir. The properties of the hypothetical reservoir and the three reservoir fluids investigated are depicted in Exhibit 3-14.

Fluid "A" was selected because of its high liquid yield and retrograde loss characteristics. Fluids "B" and "C" are the compositions of the equilibrium gas obtained during the depletion of Fluid "A" at 4015 psia (27.68 MPa) and 3415 psia (23.85 MPa), respectively. The three fluids exhibited stock-tank liquid contents of 220.7, 138.6, and 76.1 bbl/MMCF (1.24, .778 and  $.428 \text{ m}^3/\text{Mm}^3$ ) at their respective dew points and pressures. Exhibit 3-15 shows the retrograde behavior and stock-tank liquid content of the three fluids investigated as a function of reservoir pressure.

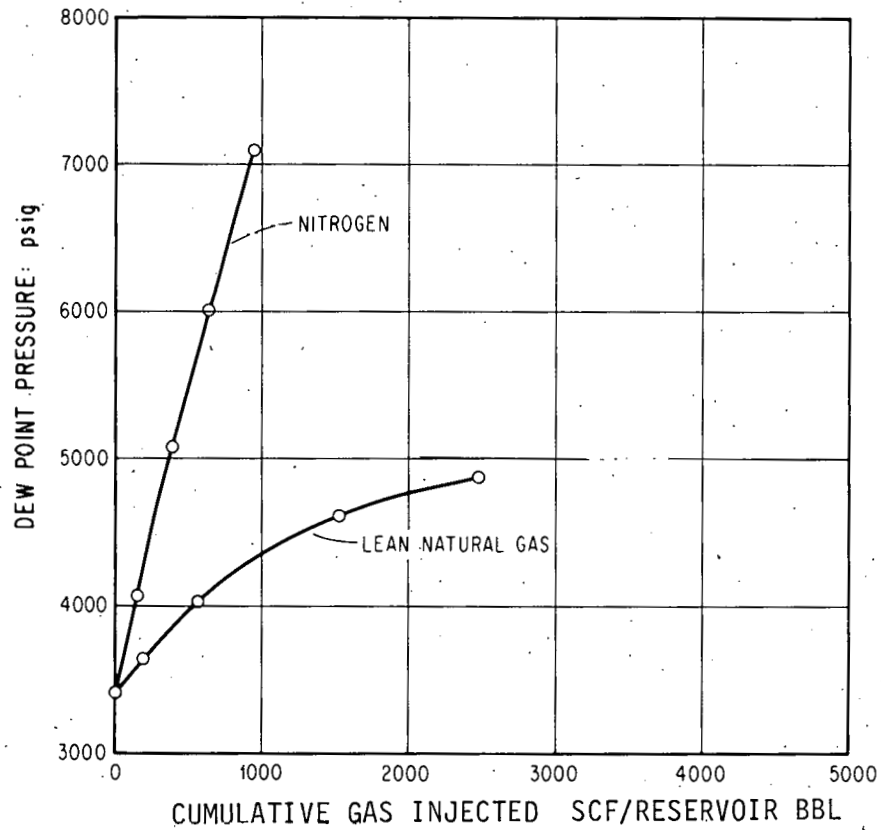

SI Metric Conversion Factors

psi x 6.894757 E - 03 = MPa

SCF/bbl x 1.781 E - 01 = m<sup>3</sup>/m<sup>3</sup>

Exhibit 3-13. Dew Point Elevation with Nitrogen and Lean Gas

Source: Ref. 3-5

### BASIC RESERVOIR PROPERTIES

Average Depth, ft (m)	10,000 (3048)
Initial Reservoir Pressure, psia (MPa)	4,475 (30.85)
Reservoir Temperature, °F (°C)	194 (90)
Total Field Area, acres ( $10^6$ m <sup>2</sup> )	2,880 (11.65)
Average Thickness, ft (m)	50 (15.24)
Average Porosity, percent	19.8
Average Water Saturation, percent	34.9
Hydrocarbon Pore Volume, MM bbl ( $10^6$ m <sup>3</sup> )	144.0 (22.89)

	FLUID		
	"A"	"B"	"C"
Original Volumes in Place			
Gas, Billion cu. ft. (Billion m <sup>3</sup> )	200.506 (5.6777)	208.307 (5.8986)	212.300 (6.0117)
Condensate, Million bbl (Million m <sup>3</sup> )	44.252 (7.0355)	28.871 (4.5901)	16.150 (2.5676)

Exhibit 3-14 Properties of Hypothetical Reservoir and Three Reservoir Fluids

Source: Ref. 3-7

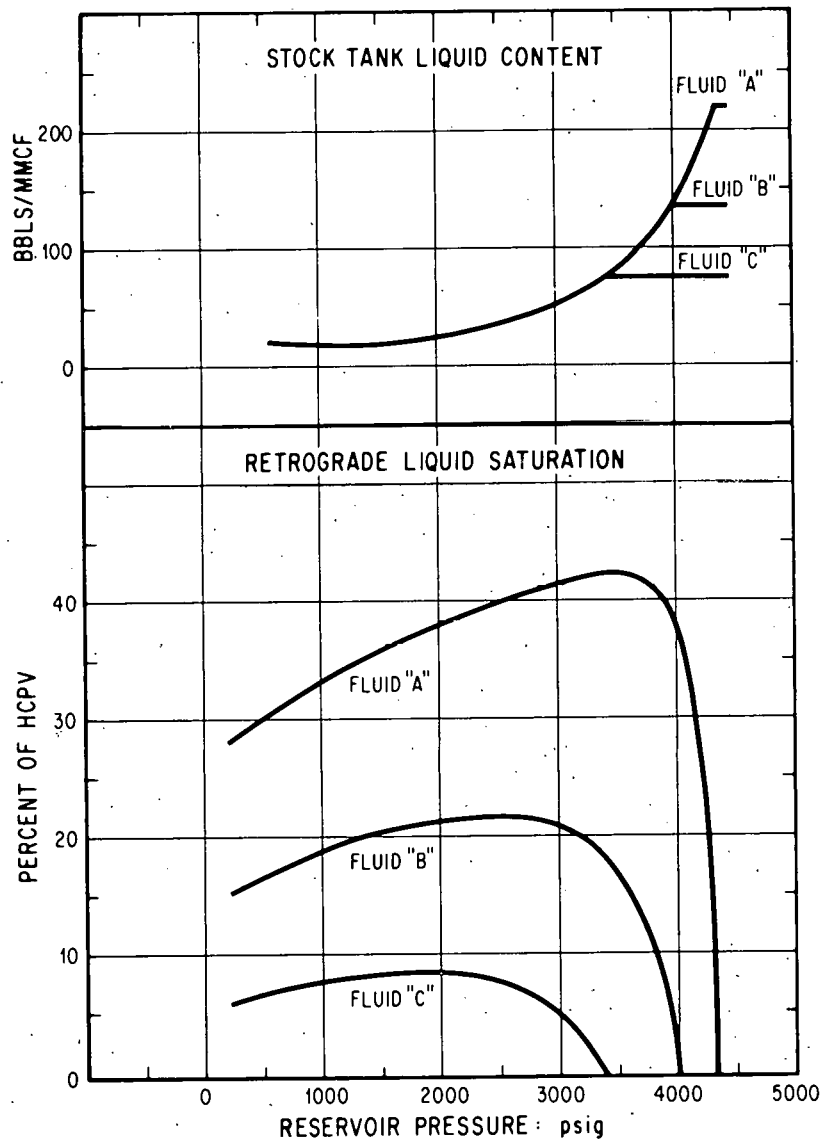

SI Metric Conversion Factors

psi x 6.894757 E - 03 = MPa

bb1/MMSCF x 5.614 E - 06 = m<sup>3</sup>/m<sup>3</sup>

Exhibit 3-15 Stock-tank Liquid Content and Retrograde Liquid Saturation

Source: Ref. 3-7

Performance projections were made for each of the three reservoir fluid systems previously described, assuming three different depletion methods: 1) pressure depletion - no injection, 2) pressure maintenance - nitrogen injection, and 3) pressure maintenance - residue and makeup gas injection. It was assumed that a 33.0 MMCFD (934.56 Mm<sup>3</sup>/day) processing plant would be used. Injection rates were limited by this capacity. Observations indicated that cycling becomes less attractive economically as the reservoir fluids become leaner, and as the reservoir becomes more heterogeneous.

An economic evaluation showed that the cost of nitrogen is dependent upon energy costs, capital and operating costs varying with location, and the nitrogen rejection facility required to remove nitrogen from products. Nitrogen production economics are discussed in Section 5 of this report.

### Conclusions

Nitrogen injection is an economically attractive and effective gas displacement technique for gas condensate reservoirs. The dew point pressure is higher for nitrogen than for natural gas. An extremely unfavorable mobility ratio or pore size distribution could lead to significant mixing within the reservoir. Therefore, fluid and rock properties should be evaluated to determine if mixing caused by these phenomena is likely to be unacceptably high. It may be desirable to plan and control injection and production rates in order to minimize the occurrence of flow pattern changes. Diffusion and dispersion will not, by themselves, be serious problems. Severe retrograde loss will occur where the nitrogen and condensate mix. Packed column displacement studies indicate that very little mixing will actually occur, and that for all practical purposes, nitrogen is as effective as lean natural gas in displacing condensate from porous media.

### 3.2 FLUE GAS INJECTION (Ref. 3-8 through 3-12)

Flue gas (inert gas, exhaust gas) is a loosely used industry term for a gas consisting mainly of CO<sub>2</sub> and nitrogen with some impurities. Sometimes nitrogen is also referred to as an inert gas. The terminology is based usually on the source of the gas. When the gas is produced by the incineration or burning of fuel such as natural gas (or other fossil fuels), the effluent is referred to as flue gas. When the gas is produced from the exhaust of internal combustion engines (that are required for compression of

the injection gas), it is referred to as exhaust gas (see Ref. 3-8 for a differentiation between flue gas and exhaust gas). In general, the composition of flue gas ranges from: CO<sub>2</sub>--10 to 15 percent; nitrogen--80 to 85 percent; and the rest small amounts of impurities.

Flue gas has been used (see Section 4-2) as an injection gas in EOR. The effectiveness of flue gas falls in between CO<sub>2</sub> and nitrogen, depending on its composition and several specific reservoir and process parameters (see Section 6). Flue gas is preferred for heavy oil reservoirs (over nitrogen). The method is founded on the viscosity reducing effect of CO<sub>2</sub> (which is a component of flue gas) dissolved in heavy (low API gravity) crude oil (Ref. 3-9). Exhibit 3-16 shows the results of laboratory tests of various gravity crude oils when subjected to CO<sub>2</sub> at various pressures. These curves show that drastic reductions in viscosity are obtained with small amounts of CO<sub>2</sub> dissolved in the oil at relatively low saturation pressures. The viscosity reduction is considerably greater with CO<sub>2</sub> in solution than through thermal effects.

Flue gas has also been proposed as a chase gas. In this application, the flue gas is used either to push a slug of hydrocarbon gas in a high-pressure, gas-injection operation, or to push a propane slug in a miscible-slug process. Laboratory experiments were conducted using nitrogen instead of flue gas in order to show the effectiveness of this process. As the CO<sub>2</sub> from flue gas dissolves in oil, for practical purposes N<sub>2</sub> is used to study the effectiveness of the process. The reservoir fluid (properties are shown in Exhibit 3-17), was displaced by nitrogen and lean gas through a 123 foot (37.5 m) unconsolidated sand-packed column at various pressures. The flue gas front was considered to be 100 percent nitrogen since CO<sub>2</sub> was stripped from the gas stream by solution in the interstitial water. The miscibility pressure for nitrogen was 3870 psi (26.68 MPa), which was only 370 psi (2.55 MPa) greater than the miscibility pressure for lean gas. Results with other gases indicated that a dilution of the nitrogen with relatively small amounts of hydrocarbon gas can be helpful in reducing the miscibility pressure (Ref. 3-10).

Flue gas has a volumetric advantage over hydrocarbon gas. A given volume of lean hydrocarbon gas uses ten times the volume of air for combustion. The resulting flue gas, after removal of water vapor, still has nine times the original volume of lean gas. Flue gas also has a greater compressibility

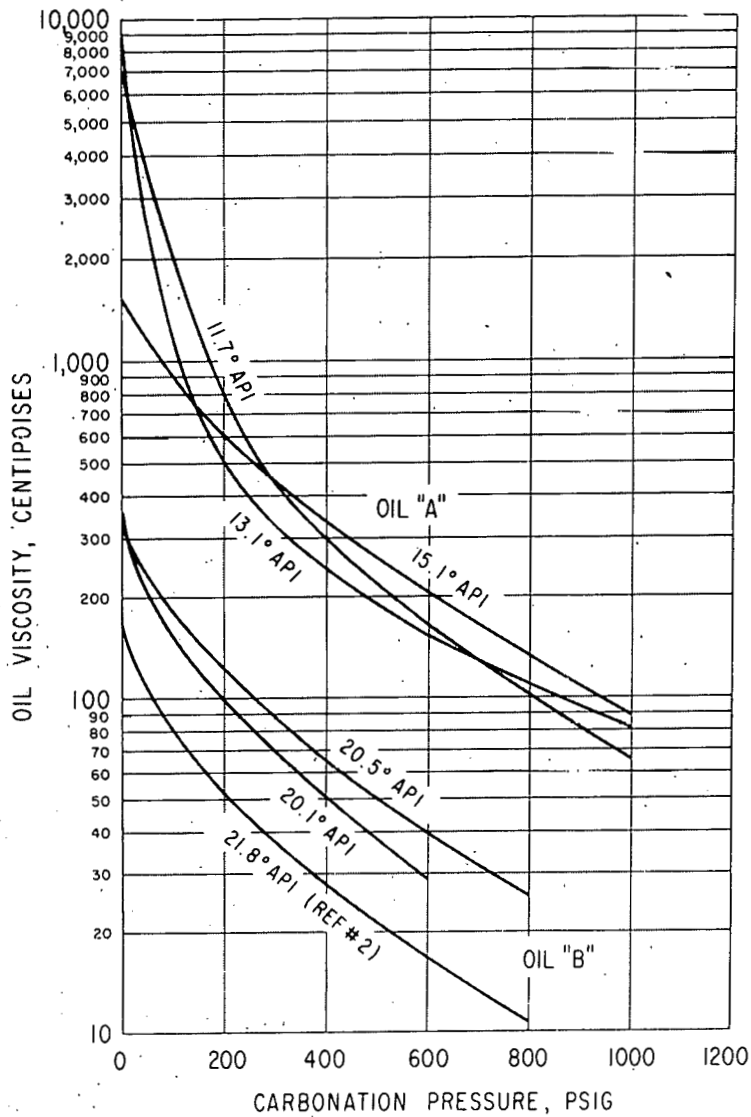

SI Metric Conversion Factors

psi x 6.894757 E - 03 = MPa

CP x 1 = MPa.S

Exhibit 3-16 Reduction in Heavy Crude Viscosity Can Be Obtained from Small Amount of CO<sub>2</sub> in Solution

Source: Ref. 3-9

### Reservoir Fluid Designation

<u>Composition</u>	<u>A</u>	<u>B</u>	<u>C</u>	<u>D</u>
N <sub>2</sub>		0.8	0.3	
C <sub>1</sub>	42.7	13.0	21.2	51.4
C <sub>2</sub>	12.5	13.2	10.0	11.2
C <sub>3</sub>	10.2	13.3	11.3	8.8
C <sub>4</sub> g	6.2	8.4	8.5	5.4
C <sub>5</sub> g	3.8	6.1	6.2	2.6
C <sub>6</sub>	3.3	4.5	5.2	1.8
C <sub>7</sub> <sup>+</sup>	<u>21.3</u>	<u>40.7</u>	<u>37.3</u>	<u>18.9</u>
	100.0	100.0	100.0	100.0
MWC <sub>7</sub> <sup>+</sup>	191	197	194	142
Bubble pt.				
Psig/	2,760/	905/	1,240/	3,780/
(MPa)	(19.03)	(6.24)	(8.55)	(26.06)
Temperature				
°F/	140/	176/	176/	237/
°C	(60)	(80)	(80)	(114)

### GAS COMPOSITION

<u>Component</u>	<u>Flue Gas</u>	<u>Lean Gas</u>
N <sub>2</sub>	88.0	1.0
C <sub>1</sub>		88.0
C <sub>2</sub>		8.6
C <sub>3</sub>		0.3
CO <sub>2</sub>	<u>12.0</u>	<u>2.1</u>
	100.0	100.0

Exhibit 3-17 Properties of Reservoir Fluids and Gas Composition

Source: Ref. 3-10



factor. A unit volume of flue gas occupies about 1.2 times the reservoir volume of that occupied by methane at pressures in the 3500 to 4000 psi (24.13 to 27.58 MPa) range and at a temperature of 105°F (87.2°C). An alternative approach in the application of exhaust gas to a heavy oil reservoir is discussed in Ref. 3-9 and 3-13. In this approach, conditioned exhaust gas or flue gas is injected in the injection well. This gas consists of about 87 percent nitrogen, and 11 to 13 percent CO<sub>2</sub> and inert gases. The CO<sub>2</sub> is readily absorbed into the reservoir oil surrounding the wellbore. Inert nitrogen is not absorbed but fills available pore space further back into the reservoir. The CO<sub>2</sub> not only reduces the reservoir oil viscosity around the wellbore, but also induces a swelling of the oil. The injection process is then reversed, and the injection well is converted into a producing well. Reservoir pressure is artificially induced by the larger volumes of nitrogen which provide the necessary energy to easily push the thinned-out oil around the well. When carbonated oil production reaches a low level, the process is reversed again, and the producing well becomes an injection well. The produced carbonated oil around the wellbore is replaced by the heavier reservoir oil which migrates into the pressure sink caused by production. Movement of reservoir oil toward the wellbore is a result of the natural reservoir energy, supplemented by the energy supplied by the compressed nitrogen.

As exhaust gas enters the oil reservoir, a relative permeability is formed immediately around the wellbore in the reservoir rock. With heavy oil saturating the rock pore-space, the gas saturation remains quite low. As the gas continues to move out into the reservoir, the oil swells with the solution of CO<sub>2</sub>, and the gas saturation remains very low with oil saturation high. At the time of reversal of the flow of carbonated oil back into the same well, the swelling effects of the oil have left the reservoir rock with a high relative permeability to oil and therefore, a low gas-oil ratio. This means that the nitrogen is retained in the reservoir away from the producing well, until a considerable amount of treated oil is back-flowed through the well and recovered.

Flue gas flooding in EOR has been applied in the field with mixed success. Field applications of flue gas flooding are discussed in Section 4.2.

### 3.3 OTHER GASES (EXCLUDING CO<sub>2</sub> AND HYDROCARBON GASES)

Other gases such as air, SO<sub>2</sub>, and acid gas (containing H<sub>2</sub>S) have been proposed and used as injection gases in EOR (see Section 4.3).

#### 3.3.1 AIR INJECTION (Ref. 3-14)

Air is approximately 79 percent nitrogen and 21 percent oxygen. When air is injected into warm reservoirs over a period of time, spontaneous ignition occurs. This converts oxygen into CO<sub>2</sub>. As this gas moves through the reservoir, CO<sub>2</sub> is dissolved by residual oil and connate water, leaving nitrogen as the piercing gas.

The possibility of obtaining a miscible drive with air can be seen from convergence pressure or miscible chart for methane and petroleum fractions (see Exhibit 3-18) assuming nitrogen in air can also achieve miscibility with petroleum fractions. The convergence pressures are fairly high. However, it is possible to achieve miscibility at a lower pressure in a reservoir because of the continuous enrichment process of the piercing gas.

Oil recoveries in excess of 90 percent have been obtained from a 43<sup>o</sup> API gravity crude oil using a 40 foot (12.2 m) sand pack in the laboratory. Initial tests were made at pressures up to 8000 psi (55.16 MPa), but it is believed that substantially the same recovery could be achieved at lower pressures, perhaps as low as 4000 psi (27.58 MPa), depending on the characteristics of the crude oil and the reservoir temperature.

Field applications of air injection in EOR are discussed in Section 4-3.

#### 3.3.2 SULFUR DIOXIDE FLOODING FOR EOR (Ref. 3-15)

The concept of this process is to inject a slug of SO<sub>2</sub> in liquid or gaseous form in the reservoir, generally followed by a water or a gas drive (CO<sub>2</sub>, N<sub>2</sub> or natural gas can be used) that pushes the bulk of SO<sub>2</sub> through the formation. Propane or butane can be used as a light hydrocarbon, liquid solvent vehicle, preferably carrying a major weight proportion of the SO<sub>2</sub>.

Pure dry SO<sub>2</sub> gas or liquid is noncorrosive, and may be safely handled in copper lines with copper or brass fittings. However, very small amounts of water vapor in SO<sub>2</sub> gas or very small amounts of SO<sub>2</sub> dissolved in water are highly corrosive mixtures and must be handled in specially designed systems or in materials fabricated with special alloys or linings. For example, pure dry

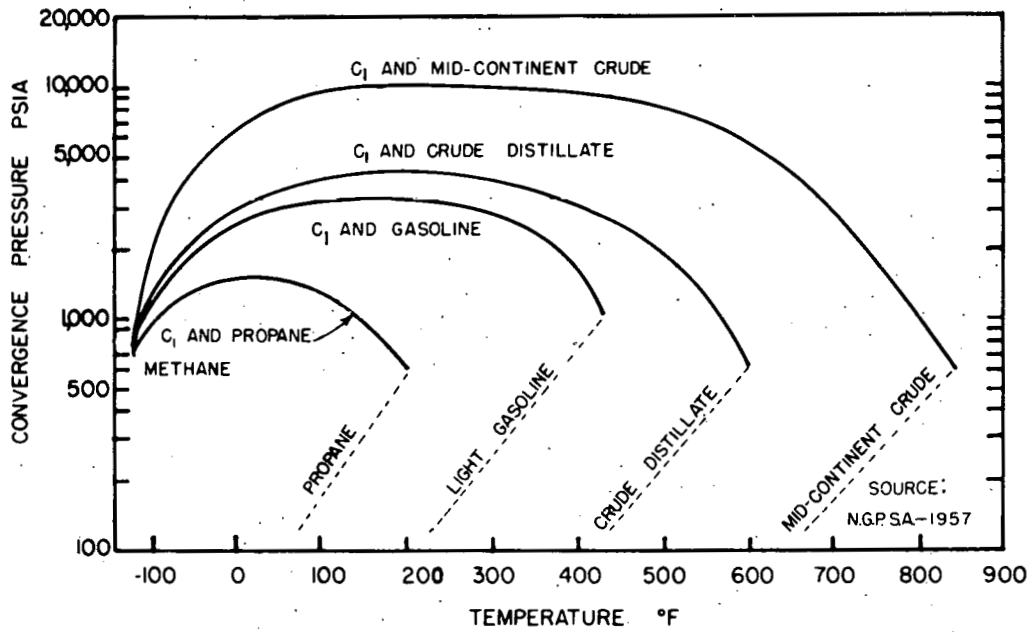

SI Metric Conversion Factors

psi x 6.894757 E-03 = MPa

(°F - 32) 5/9 = °C

Exhibit 3-18 Convergence Pressure of Methane and Petroleum Fractions

Source: Ref. 3-14

liquid or gaseous  $\text{SO}_2$  can be injected by small diameter tubing directly into a well bottom and will commingle and dissolve any solvent vehicle (when such vehicle is pumped down by another tubing). In order to avoid corrosion of the casing above the tubing, a packer may be employed near the the well bottom to close off the area of the well above the packer. This should be done wherever there is a possibility of  $\text{SO}_2$  corrosion. Piping, fittings, valve seats and plugs, gauges, and control elements may be fabricated of, or lined with, lead, plastic, or with an alloy such as "Hastelloy", "Stellite" or Monel metal. These are resistant to corrosive action by  $\text{SO}_2$ .

In carbonate reservoirs, carbon dioxide would be generated in situ through reactions of weak acids (generated by  $\text{SO}_2$ ) with carbonate rocks. Thus,  $\text{CO}_2$  will help to sustain formation pressure and lower oil viscosity as it is dissolved in oil.  $\text{SO}_2$  dissolved in water produces sulfuric acid ( $\text{H}_2\text{SO}_3$ ), which reacts with the limestone or dolomite producing bisulfites, and liberates  $\text{CO}_2$  as shown in the following reactions.

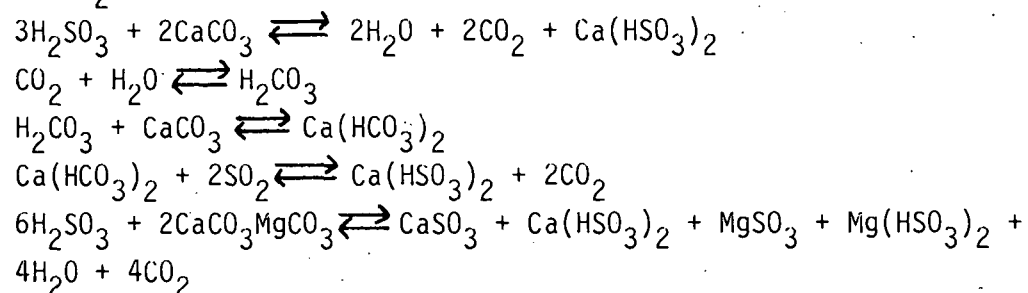

The products are  $\text{CO}_2$ , calcium bisulfite, and magnesium bisulfite, all of which are readily soluble in water. At reservoir conditions, the equilibrium of the above reactions is highly stable, and precipitation (and plugging of channels) is therefore, a relatively insignificant possibility. Permeability of the rock is increased due to reactions of the weak acids with rocks. Any generated  $\text{CO}_2$  assists in reducing the viscosity of the crude oil in which it dissolves. In addition, because the  $\text{SO}_2$  is used up in the above reactions, it is not part of the produced oil. Thus, there is no possibility of corrosion problems at the production well or in surface equipment.

The process has been successfully tested in the laboratory using cores from various reservoir rocks and crude oils. These laboratory studies showed that  $\text{SO}_2$  added to flood water in a proportion as low as one part per thousand by volume results in an improved recovery, amounting to as much as 50 percent of total recovery compared with a pure water flood. The laboratory experiments and the results are further described in Ref. 3-15. The results suggest that the process may be promising for use in EOR.

## References

- 3-1 Rushing, M. D., B. C. Thomasson, B. Reynolds, and P. B. Crawford, "Nitrogen May Be Used for Miscible Displacement in Oil Reservoirs," Journal of Petroleum Technology, December 1978, p. 1715-1716.
- 3-2 Rushing, M. D., B. C. Thomasson, B. Reynolds, and P. B. Crawford, "Miscible Displacement with Nitrogen," Petroleum Engineer, November 1977, p. 26-30.
- 3-3 Peterson, A. V., "Optimal Recovery Experiments with N<sub>2</sub> and CO<sub>2</sub>," Petroleum Engineer International, November 1978, p. 40-50.
- 3-4 O'Leary, J. P., T. H. Murray, T. Guillory, C. Grieve, M. C. Reece, M. Nugent, T. Perkins, and P. B. Crawford, "Nitrogen Driven CO<sub>2</sub> Slugs Reduce Costs," Petroleum Engineer, May 1979, p. 130-140.
- 3-5 Moses, Philip L., and Keith Wilson, "Phase Equilibrium Considerations in Utilizing Nitrogen for Improved Recovery from Retrograde Condensation Reservoirs," SPE 7493, 53rd Annual Technical Conference and Exhibition, SPE/AIME, Houston, Texas, October 1-3, 1978.
- 3-6 Vogal, John L., and Yarborough, Lyman, "The Effects of Nitrogen on the Phase Behavior and Physical Properties of Reservoir Fluids," SPE 8815, First Joint SPE/DOE Enhanced Oil Recovery Symposium, Tulsa, Oklahoma, April 20-23, 1980.
- 3-7 Donohoe, Charles W., and R. D. Buchanan, "Economic Evaluation of Cycling Gas - Condensate Reservoirs with Nitrogen," SPE 7494, 53rd Annual Technical Conference and Exhibition, SPE/AIME, Houston, Texas, October 1-3, 1978.
- 3-8 Wilson, K., "Enhanced Recovery Inert Gas Processes Compared," Oil and Gas Journal, July 31, 1978, p. 162-172.
- 3-9 Clark, Norman J., Thomas G. Roberts, and J. Dorsey Lindner, "Engine Exhaust Gas Boosts Heavy Oil Recovery," Petroleum Engineer, August 1964, p. 43-47.
- 3-10 Hutchinson, C. A., and H. A. Koch, "Miscible Displacement of Reservoir Oil Using Flue Gas," Petroleum Transactions, AIME V. 213, 1958, p. 7-10.
- 3-11 Davison, K., "Inert Gas Generators Stimulate Viscous Oil Flow," Petroleum Equipment, March-April 1966, p. 6-8.
- 3-12 Herbeck, E. F., R. C. Heintz, and J. R. Hastings, "Fundamentals of Tertiary Oil Recovery," Petroleum Engineer, April 1976, p. 66-72.
- 3-13 Glass, Eugene D., and Colonel J. Russell Jr., "Heavy Oil Recovery," U. S. Patent No. 3,373,804, March 19, 1968.

- 3-14 Rushing, Michael D., Bruce C. Thomasson, Bruce Reynolds, and Dr. Paul B. Crawford, "High Pressure Air Injection," Petroleum Engineer, November 1976, p. 52-56.
- 3-15 Mulder, F. R. E., "Formation Flooding by Sulfur Dioxide for Recovering Oil and Gas," U. S. Patent No. 3,359,597, November 21, 1967.

#### 4.0 FIELD BASED ACTIVITIES

Gas injection has long been used in oil recovery. The reinjection of natural gas to maintain pressure and extend the life of solution gas drive production has long been a commercial practice. CO<sub>2</sub> injection in gas miscible displacement is a more recent practice and presently is being used at pilot- and demonstration-scales, primarily because it is cheaper than natural gas. In the last several years, attention has focused on other gases such as nitrogen and flue gas as possible injection gases. Their advantage is that they are even cheaper than CO<sub>2</sub>. Their use has increased from only one project in 1974 to eight projects in 1980, as shown in Exhibit 4-1. This Exhibit shows the downward trend in the use of hydrocarbon miscible gas and the upward trend in the utilization of CO<sub>2</sub>. This Section deals with the use of gases other than CO<sub>2</sub> and hydrocarbon gas for EOR in the field.

EOR METHODS	NUMBER OF ACTIVE PROJECTS				
	1971	1974	1976	1978	1980
Thermal Methods					
Steam	53	64	85	99	133
Combustion in situ	38	19	21	16	17
Chemical Methods					
Micellar-polymer	5	7	13	22	14
Polymer	14	9	14	21	22
Caustic	0	2	1	3	6
Gas Methods					
CO <sub>2</sub> miscible	1	6	9	14	17
Hydrocarbon miscible	21	12	15	15	9
Other gases	0	1	1	6	8

Exhibit 4-1 Active Enhanced Oil Recovery Projects in the United States by EOR Method

Source: Ref. 4-1

## 4.1 NITROGEN INJECTION

Nitrogen can be used as a miscible agent in EOR if reservoir pressures are kept high enough (above 5000 psia or 34.47 MPa). However, most current field projects use nitrogen for pressure maintenance, or to prevent retrograde condensation in the additional recovery of oil from a reservoir. The location, general history, geologic and petrophysical characteristics, and reservoir performance for the following specific projects are summarized below:

- o Nitrogen flooding in Fardoche Field, Louisiana
- o Nitrogen flooding in Ryckman Creek, Uinta County, Wyoming
- o Potential use of nitrogen injection in Painter Reservoir, South Wyoming
- o Potential use of nitrogen WAG injection in Jay/LEC Field
- o Potential use of nitrogen injection in Stonebluff Field, Oklahoma

### 4.1.1 NITROGEN FLOODING IN FORDOCHE FIELD, LOUISIANA (Ref. 4-1,4-2,4-3)

#### Location and General History

The Fardoche Field was discovered in 1965 in southwestern Pointe Coupee Parish, Louisiana (Exhibit 4-2). It is being operated by Sun Oil Company. Forty-seven oil and seven gas completions were registered for the field with a 160 acre (.6475 km<sup>2</sup>) spacing. Oil production from the W-8 and W-12 reservoirs peaked at about 9000 barrels of oil per day (BOPD) (1431 m<sup>3</sup>/d) in 1969. By 1972 it had declined to 500 BOPD (79.5 m<sup>3</sup>/d). Natural gas injection began in 1971, but natural gas supplies and prices forced Sun Oil Company to look into nitrogen injection as an alternative to natural gas injection. There are 19 producing and 3 injection wells in the field.

#### Geologic and Petrophysical Data

The W-8 and W-12 sandstone reservoirs are Wilcox sand of deltaic origin. They vary from slightly shaley and fine-grained to silty sandstone, and they contain varying amounts of clay. They are generally persistent throughout the field and are horizontally continuous. Permeabilities range from 6 to 10 md ( $5.92 \times 10^{-3}$  to  $9.89 \times 10^{-3}$   $\mu\text{m}^2$ ) and the average porosity is 16 percent. The depth of the formation is at 13,250 feet (4039 m); the formation temperature is 270<sup>o</sup> F (132<sup>o</sup> C). The 44<sup>o</sup> API oil has a viscosity of .13 cp ( $1.3 \times 10^{-4}$



# Where Sun is injecting nitrogen

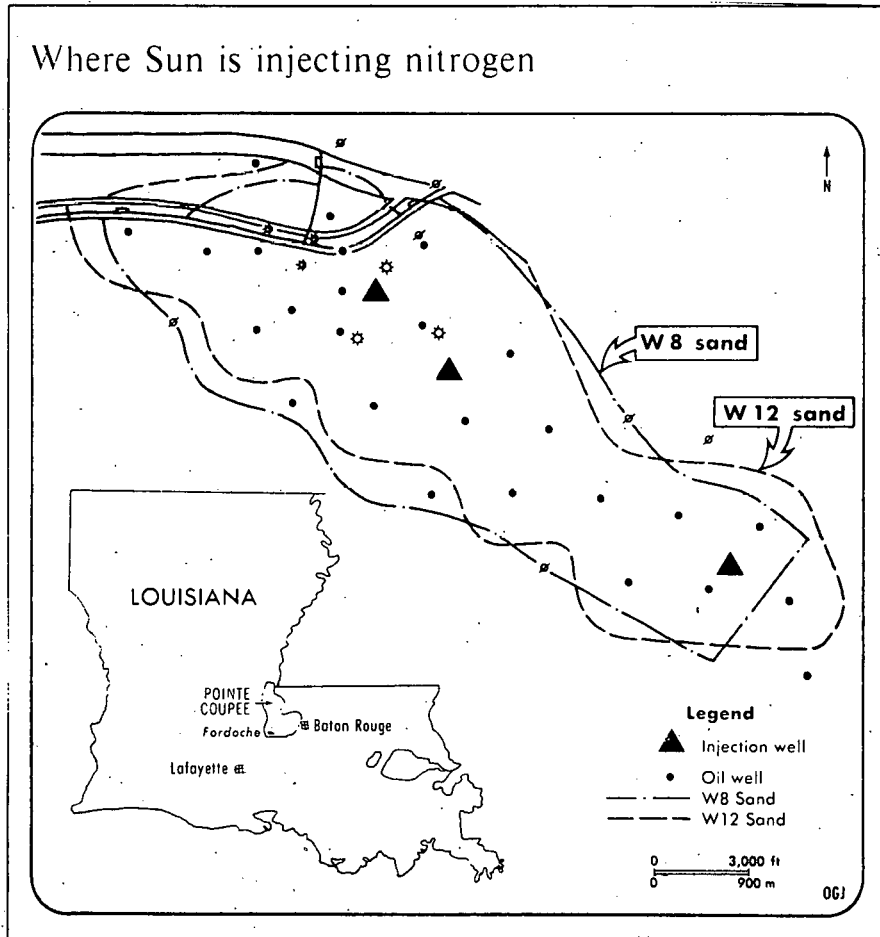

Exhibit 4-2 The Location of Fordoche Field

Source: Ref. 4-2

Pa.S). The residual oil saturation at the start of natural gas injection was 53 percent and was 28 percent when gas injection was completed.

#### Reservoir Performance

Sun Oil Company initiated a nitrogen injection program in two reservoirs in Fordoche Field on January 31, 1977. Sun Oil expects the program to add 18 to 20 million bbl (2.86 to 3.18 million m<sup>3</sup>) to the field's ultimate production, and anticipates substantial savings from the substitution of nitrogen for natural gas. There is one nitrogen plant presently producing in the field with plans for a second. Sun Oil is injecting nitrogen at a rate of 6.1 million cubic feet per day (MMCFD) (.17 MMm<sup>3</sup>/d) and is recovering field produced gas at 15 MMCFD (.425 MMm<sup>3</sup>/d). The nitrogen injection rate will increase to 10 MMCFD (2.83 MMm<sup>3</sup>/d) upon completion of the second plant. The bottom-hole pressure is being maintained at 7000 psig (48.26 MPa) in the two reservoirs.

Oil production was 1,100 BOPD (175 m<sup>3</sup>/d) in 1977, and was expected to rise to 3000 BOPD (477 m<sup>3</sup>/d) upon completion of the second plant. 1979 EOR production was 2,027 BOPD (322 m<sup>3</sup>/d). Nitrogen injection was in progress as of March 31, 1980. The project has been profitable, and is considered successful.

The injection program is expected to keep the field producing at least for another 20 years. If the project were shut down now, the field would be unable to produce in about 1 1/2 years.

Sun Oil chose nitrogen over natural gas because it offers a fast and economical means of boosting the low reservoir pressures that were cutting oil production.

#### 4.1.2 NITROGEN FLOODING IN RYCKMAN CREEK, UINTA COUNTY, WYOMING (Ref. 4-4)

##### Location and General History

The Ryckman Creek Field is located in Uinta County, Wyoming on a complex overthrust belt (Exhibit 4-3). The discovery well was completed in September 1976. The well test showed gas at rates above 3000 MCFD (84.95 Mm<sup>3</sup>/d) from an overlying gas-cap, and oil at 500 BOPD (79.5 m<sup>3</sup>/d) and gas at 700 MCFD (19.82 Mm<sup>3</sup>/d) from the oil zone. Development was begun on an 80 acre (.324 km<sup>2</sup>) spacing. The original oil in place is estimated to be 78 million stock tank barrels (STB) (12.4 MMm<sup>3</sup>) with 110 billion cubic feet (BCF) (3.12 billion m<sup>3</sup>) solution gas and 90 BCF (2.55 billion m<sup>3</sup>) gas-cap gas. High purity nitrogen

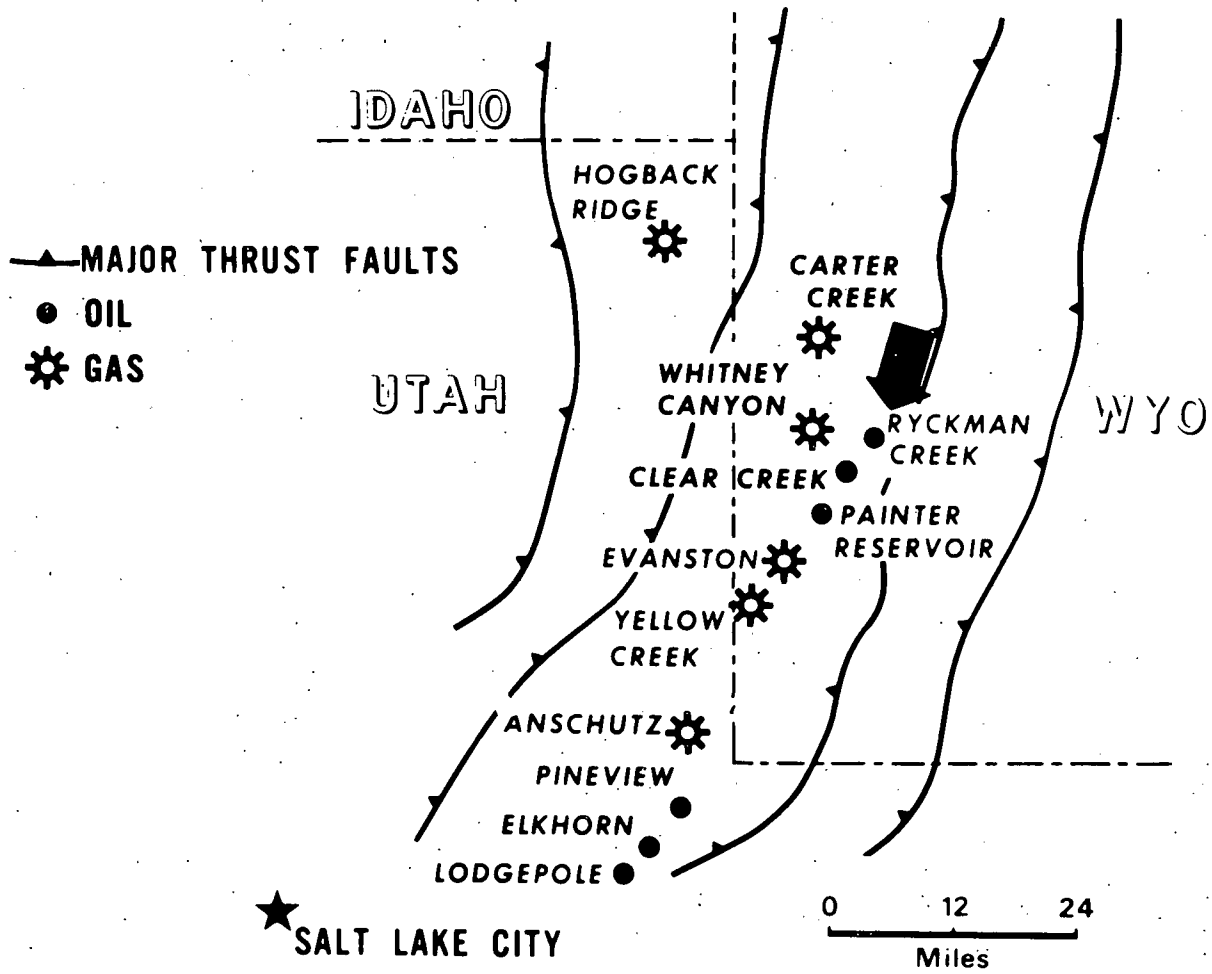

Exhibit 4-3 Location Map of Ryckman Creek Field, Uinta County, Wyoming

Source: Ref. 4-4

will be manufactured at 12 MMCFD (.34 MMm<sup>3</sup>/d) and will be injected into the top of the gas cap. The gas cap will then be simultaneously produced with the oil column. Predictions indicate that a 27 year improvement will be made in the timing of gas-cap gas sales and a minimum of 15 BCF (.415 billion m<sup>3</sup>) gas reserve increase should be seen over the blow-down period.

#### Geologic and Petrophysical Data

The Ryckman Creek Field is an asymmetrical anticline containing a thick gas cap, an oil zone, and a water zone (see Exhibit 4-4). The anticline is approximately three miles long (4828 m) and one and one-half miles (805 m) wide. The overall sand thickness is 815 feet (248.4 m). The maximum gas cap thickness is approximately 400 feet (122 m) and the oil column is about 200 feet (61 m) thick. The field is completely underlain by water, and a strong water drive is expected. The average porosity is 14.7 percent and the average permeability is 90.2 md (.089 μm<sup>2</sup>). The initial reservoir pressure was 2900 psi (20 MPa); the reservoir temperature is 140°F (60°C).

#### Rock and Fluid Properties

The Ryckman Creek Field produces a sweet crude oil with an API gravity of 47°. The solution gas-oil ratio (GOR) is 1420 SCF/bbl (752.9 m<sup>3</sup>/m<sup>3</sup>) and the oil formation volume factor is 1.705. The connate water saturation in the field is 20.6 percent. The producing sand is very clean, containing practically no clays or other impurities. Although the sand is cross-bedded, it is shown to be continuous by the almost complete lack of shale breaks in well logs. The cores that were taken showed consistent porosity and permeability, and a high water displacement efficiency.

#### Reservoir Performance

The oil zone is being produced by a water drive as shown in a computer study. This study also indicated that there would be a severe loss in oil reserves if the gas-cap were blown-down within the first 27 years of depletion. Tests indicated that there would be a very high residual gas saturation of 55 percent if the gas were displaced by water. This would result in gas recovery of 37 1/2 percent in areas contacted by water. An evaluation program was undertaken to find a satisfactory replacement gas which would allow the gas-cap to be immediately placed on production.

Nitrogen was chosen as the replacement gas for the following reasons:

- Favorable physical properties - density, viscosity, and volume.
- Relatively pure, and therefore, corrosion free.

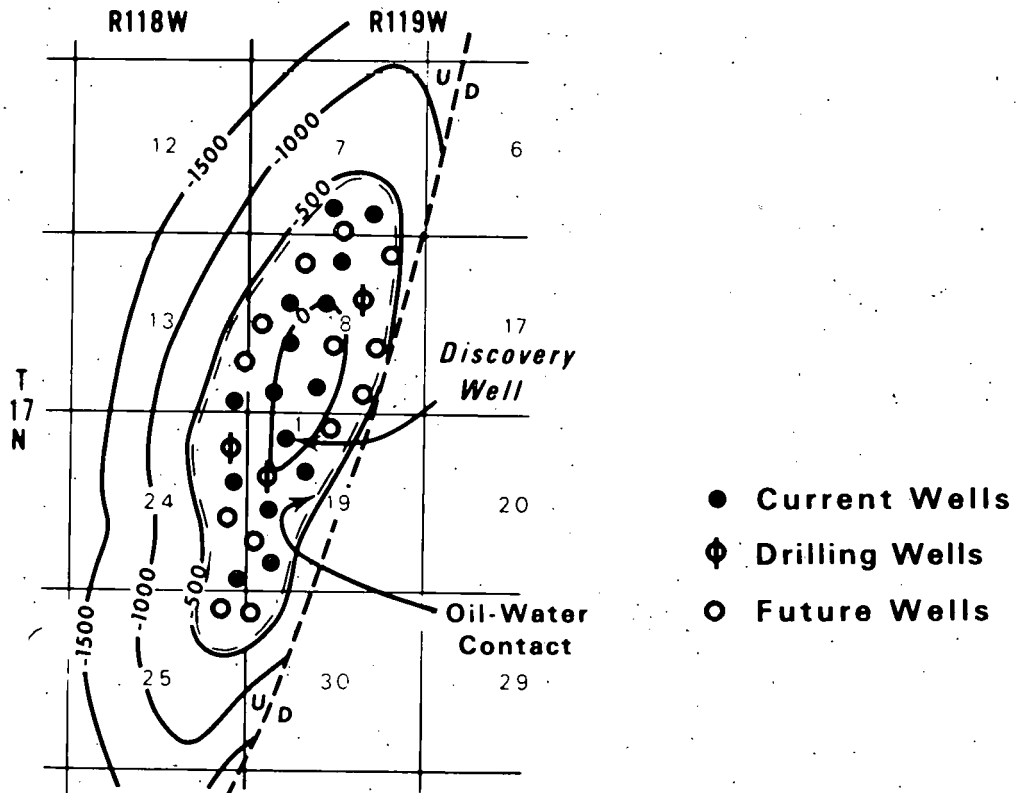

Exhibit 4-4 Status and Structure Map of Ryckman Creek Field

Source: Ref. 4-4

- Readily and dependably available.
- Non-polluting.
- No adverse phase behavior effects.
- Ease of gas processing and cleanup.
- Price.

### Nitrogen Injection Project Results

Estimates for gas production rates without nitrogen injection indicate that the gas-cap blow-down will not commence until the year 2006, when oil production will have decreased to 500 BOPD ( $79.5 \text{ m}^3/\text{d}$ ). Blow-down will occur from nine wells at 3000 MCFD ( $84.95 \text{ Mm}^3/\text{d}$ ), and will be complete by the year 2013. Ultimate recovery will reach 105 BCF ( $2.973 \text{ billion m}^3$ ) with a large percentage obtained in the last few years of the gas cap blow-down. With nitrogen injection of 12 MMCFD ( $.34 \text{ MMm}^3/\text{d}$ ) starting January 1, 1980, an incremental 16 MMCFD ( $.453 \text{ MMm}^3/\text{d}$ ) of hydrocarbon gas can be produced from the gas cap, and ultimate recovery would then reach 120 BCF ( $3.398 \text{ billion m}^3$ ) in 1995. Thus, by January 1, 1990 an incremental 15 BCF ( $.425 \text{ billion m}^3$ ) will have been recovered with the use of nitrogen. When the field is blown-down, much of the gas trapped by the water drive will be inexpensive nitrogen rather than hydrocarbon gas.

### Conclusion

The nitrogen injection project at Ryckman Creek will significantly increase gas reserves and will provide gas to the public more than 27 years earlier than would be the case using historical depletion techniques. Gas reserves will increase by at least 15 BCF ( $.425 \text{ billion m}^3$ ). This process should be applicable at other solution gas gas-cap drive fields located along the Overthrust Belt as well in other areas of the United States. Higher natural gas prices should allow the economic production of much of the hydrocarbon gas now being retained for pressure maintenance.

#### 4.1.3 POTENTIAL OF NITROGEN FLOODING IN PAINTER RESERVOIR, SOUTHWEST WYOMING (Ref. 4-1, 4-2)

##### Location and General History

The production zone in the Painter Reservoir Field is the Jurassic-Triassic Nugget sand. The reservoir is located near Ryckman Creek Field in

South Wyoming (Exhibit 4-3). In one particular well, sand at the top of the formation was at the depth of 9728 feet (2965 m).

#### Geologic and Petrophysical Data

The Nugget sandstone is typically a massive, cross-bedded, cross-laminated, uniformly porous sandstone. The sand grains are very fine to medium, subrounded, and well sorted. It is about 90 to 95 percent quartz and about 5 to 10 percent feldspar with minor amounts of calcitic, dolomitic, and illitic clay. Cores indicate an average porosity of 13 percent and an average permeability of 20 md.

#### Rock and Fluid Properties

The Painter Reservoir discovery well was officially reported to produce 410 BOPD ( $65.18 \text{ m}^3/\text{d}$ ). The initial solution GOR was 2100 SCF/STB ( $374 \text{ m}^3/\text{m}^3$ ). The initial formation volume factor was 2.13 bbl/STB ( $2.13 \text{ m}^3/\text{m}^3$ ). There is no  $\text{H}_2\text{S}$  in either the oil or the gas.

#### Reservoir Performance

Laboratory studies conducted by Chevron using Painter Reservoir crude oil showed that  $\text{CO}_2$  would be considered as a good displacement medium and  $\text{N}_2$  as possibly a better one. Again, the costs of processing and transporting  $\text{CO}_2$ , and the probable costs of corrosion control, are well above the costs of production and use associated with  $\text{N}_2$  injection. The Painter Reservoir Field was being developed on an 80 acre ( $.324\text{km}^2$ ) spacing at the end of 1978. At that time, core analyses and other mechanical studies were underway to determine the optimum method of operation. It appeared that  $\text{N}_2$  had a high potential for utilization in EOR.

A new major project is being studied for initiation in 1981. This will be the largest  $\text{N}_2$  injection program ever proposed. The initial phase of the  $\text{N}_2$  injection will be at a rate of 44 MMCFD ( $1.246 \text{ MM m}^3/\text{d}$ ). The proposal is to inject  $\text{N}_2$  into the gas-cap and to phase out natural gas injection. The project will allow for the sale of approximately 100 MMCFD ( $2.832 \text{ MM m}^3/\text{d}$ ) of natural gas. A large, air separation plant will have to be constructed. Injection pressure will be at 4800 psig (33.1 MPa), compared to 4200 psig (28.96 MPa) for natural gas.

#### 4.1.4 POTENTIAL OF NITROGEN WAG (WATER ALTERNATING GAS) FLOODING IN JAY/LEC FIELD (Ref. 4-6)

##### Location and General History

The Jay/LEC field, located in Florida and Alabama, is producing oil under unitized water flood operations. The field test was undertaken as part of an engineering evaluation of injecting nitrogen and water alternately into the Jay/LEC Field Smackover Reservoir to determine the effect on a tertiary miscible gas process.

##### Geologic and Petrophysical Data

The initial reservoir temperature was 185°F (85°C). Reservoir pressure is 7100 psi (48.95 MPa) and the average porosity is 14 percent. The average core permeability is 95.5 md, and the net thickness of the formation is 12 feet (3.66 m).

##### Predicted Reservoir Performance

Water injectivity decreased significantly in two miscible WAG projects after gas injection, and operators speculated that the precipitation of asphaltenes, the trapped residual gas saturation, or the movement of fine granules of reservoir rock caused these declines. These projects were unable to achieve the forecasted oil production rates because of the additional time required to inject the planned water volumes.

If a reduction in water injectivity occurs due to trapped CO<sub>2</sub> saturation, the high solubility of CO<sub>2</sub> in water should allow water injectivity to increase rapidly during the succeeding water injection cycle. In addition, injection wells may experience a slight permeability and porosity increase due to the solution of CO<sub>2</sub> in water forming a weak acid. In a nitrogen WAG project, the low solubility of nitrogen in water will prevent the trapped gas saturation from changing significantly during the water injection phase. WAG projects using low water soluble gases have shown significant reductions in water injectivity, while reductions were not documented when using high water soluble gases.

The results of laboratory experiments performed with cores from the Jay/LEC Field to determine if water injectivity could be reduced if nitrogen and water were injected alternately were inconsistent, possibly due to changing rock wettability and the movement of formation fines. Since these laboratory tests were inconsistent, a field test was initiated in August 1978. Reservoir injectivities and water and nitrogen transmissibilities were observed during three cycles of nitrogen followed by water injection. A



Horner analysis did not provide definitive answers. The plotting of transmissibility versus the square root of shut-in time was useful in observing fluid banks in the reservoir, and in evaluating changes in water and gas injectivities.

### Conclusions

A substantial decline (40 percent) in well water injectivity indices would occur after nitrogen injection in the Jay/LEC Field. Following nitrogen injection, water injectivity indexes would decline as the less mobile water moves out from the wells, displacing the highly mobile nitrogen. The water injectivity indices would increase as a result of the disappearance of trapped nitrogen due to its solution in the injected water. However, a typical WAG cycle is not long enough to offset the initial decline. The percentage of loss in Jay/LEC Field injectivity could be largely offset by installing larger tubing in a limited number of injection wells. A water flood following the nitrogen WAG project would increase the water injectivities in the Jay/LEC Field to at least pre-WAG levels.

The Jay/LEC data do not support attributing the water injectivity decrease to asphaltene deposition or the movement of formation fines.

## 4.2 FLUE GAS INJECTION

The idea of utilizing flue gas (i.e., exhaust gas, inert gas, acid gas) to recover oil from a reservoir is not new. The idea has been tried in various reservoirs since the 1960s but with mixed results. With the rise in the synthetic fuels industry, large quantities of flue gases will be produced. These gases will have to be expelled into the atmosphere which will pollute the air. These gases are potential injection gases in EOR (which would reduce the air pollution). The use of these gases in EOR processes is discussed in Sections 3, 6 and 7. The location, general history, geologic and petrophysical characteristics, and reservoir performance for the following specific projects are summarized below:

- Flue gas flooding at Block 31 Field, Crane County, Texas.
- Flue gas flooding at Neale Field, Beauregard Parish, Louisiana.
- Inert gas flooding in Elk Basin Field, Park County, Wyoming and Carbon County, Montana.

- Acid gas flooding and N<sub>2</sub> Chase Gas Injection in Slaughter Field, Hockley County, Texas.
- Flue gas flooding in West Heidelberg Field, Jasper County, Mississippi.
- Inert gas flooding in Iberia Field, Iberia Parish County, Louisiana.
- Flue gas flooding at East Binger Field, Oklahoma.
- Flue gas flooding at Hawkins Field, Texas.
- Inert gas flooding in the Bayou Des Glaise Field, Iberville Parish, Louisiana.
- Flue gas flooding at West Heidelberg Field, Mississippi.
- Exhaust gas injection in Weir Sand of Mingo County, West Virginia.

#### 4.2.1 FLUE GAS FLOODING AT BLOCK 31 FIELD, CRANE COUNTY, TEXAS (Ref. 4-1, 4-3, 4-7 through 4-11)

##### Location and General History

The Block 31 Field, nine miles (14.48 km) northwest of Crane, was discovered in 1945. Partial-pressure maintenance was begun in 1949 by reinjecting produced gas. The field was unitized for full-pressure maintenance in 1952.

Beginning in 1955, a high pressure, gas drive process was used in the reservoir. Extensive research showed that EOR, which would increase ultimate recovery to an estimated 60 percent of the OOIP, could be achieved by injecting lean hydrocarbon gas into the reservoir. This indicated that pressures above 3500 psi (24.13 MPa) were needed to maximize the recovery efficiency of this process. These experiments also indicated that flue gas was almost as good as lean gas for use in this process.

A flue gas generation plant was installed in 1966 that manufactured flue gas consisting of 88 mole percent nitrogen and 12 mole percent CO<sub>2</sub>.

The unit began an infill drilling program in 1973 which increased production from 12,000 to 16,000 BOPD (1908 to 2544 m<sup>3</sup>/d). The injection pattern was a 320-acre (1.295 km<sup>3</sup>) nine spot. There were 125 producing and 36 gas injection wells as of March 31, 1980.

Reservoir pressure declined from 1946 to 1949, and it continued to decline from 1950 to 1955 because reinjection was not sufficient to replace production. However, after 1955 the injection program steadily increased field pressure.

### Geologic and Petrophysical Data

The Block 31 unit is a reservoir of Middle Devonian age. The structure on top of the Devonian strata is a northeast-southwest trending anticline bounded on the south and southeast by normal faults (Exhibit 4-5). The unit has three reservoirs: upper, middle, and lower. The major reservoir (the middle) is at a depth of 8500 feet (2591 m) with a net pay zone averaging 170 feet (51.8 m). This pay zone consists of 65 percent tripolitic chert and 20 percent fine crystalline, sucrosic limestone. The remainder of the rock is variable amounts of lime mud, skeletal material, pellets, and quartz silt. The porosity is intercrystalline and averages 15 percent, and the permeability averages 1 md. Connate water saturation is 35 percent. The oil viscosity at initial pressure of 4105 psi (28.3 MPa) was 0.25 cp ( $250 \times 10^{-4}$  Pa.S) and the oil gravity was 48<sup>o</sup> API. The reservoir temperature is 140<sup>o</sup>F (60<sup>o</sup>C).

### Reservoir Performance Data

Miscible displacement was started in Block 31 many years ago, and is continuing using flue gas instead of purchased hydrocarbon gas. This has increased oil recovery and has conserved hydrocarbon gas. In the high pressure gas injection process, miscibility is relatively independent of the composition of the injected gas. The gas acquires the intermediate hydrocarbons needed for miscibility through an exchange of components with the reservoir oil. Thus, the injected gas need not be a hydrocarbon gas. An inert gas such as flue gas is equally effective in displacing certain reservoir oils.

The change to flue gas injection in Block 31 results in a slug operation, since the hydrocarbon gas already injected is about 30 percent of the pore volume. This hydrocarbon gas buffer is an added feature of this operation.

### Conclusions

High ultimate recovery from this reservoir has been achieved by maintaining reservoir pressure. The projected ultimate recovery is greater than 65 percent of the OOIP. Natural gas liquids are recovered at Block 31 and put through a gas plant that is producing a product at about one-third the rate of oil production. To date, about two-thirds of the ultimate oil recovery has been produced, whereas only about one-half of the ultimate gas plant product has been recovered.

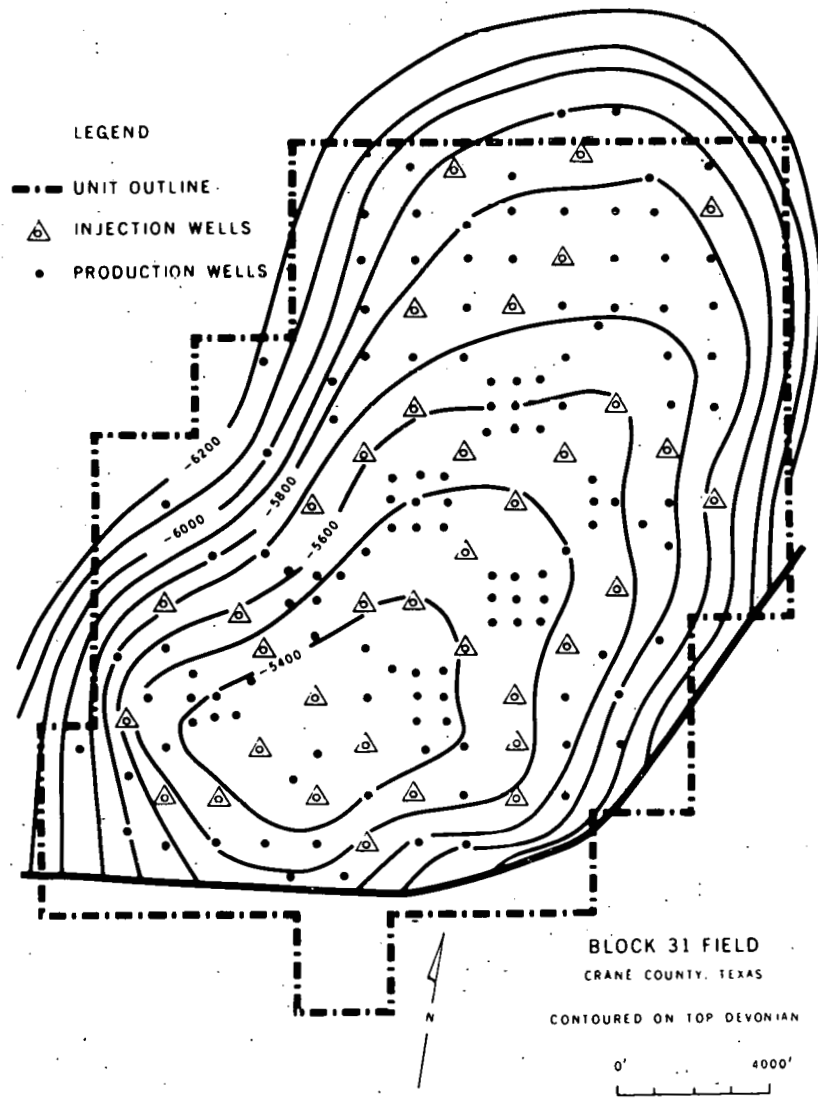

SI Metric Conversion Factors

ft. x 3.048 E - 01 = .m

Exhibit 4-5 Structure Map of Devonian Formation of Block 31 Field

Source: Ref. 4-7

#### 4.2.2 FLUE GAS FLOODING AT NEALE FIELD (Ref. 4-12)

##### Location and General History

Neale Field is located in Beauregard Parish, Louisiana (Exhibit 4-6). The field was discovered in 1940 and reached a peak oil production of about 7500 BOPD ( $1192 \text{ m}^3/\text{d}$ ) in 1944. However, later productivity became so low in individual zones that it was not economical to operate most middle Wilcox completions on a single zone basis. After unitization in 1953, common completions were made in the middle zones of the Wilcox basin, and plans for secondary recovery were initiated.

A high pressure miscible gas injection program was begun in the sand at a depth of 10,400 feet (3170 m) in 1956. In 1962, a pilot miscible slug recovery program was started in the Lilliedoll Sand using propane enriched hydrocarbon gas. This was successful, and in 1964 plans were made to expand the process to the whole reservoir. It was decided that flue gas would replace the more expensive hydrocarbon gas as the displacing medium. A flue gas plant was installed in January 1966. The gas has been used: (1) to displace hydrocarbon gas during blow-down of the sand at 10,400 feet (3170 m); (2) for the displacing phase behind the Lilliedoll Sand, rich gas slugs; and (3) for a high pressure, miscible, flue gas pilot-test in the Upper Spiers oil reservoir. Slugs of water were alternated with slugs of flue gas in order to control mobility.

##### Geologic Data

Neale Field is on an east-west trending anticline and is about five miles (8.045 km) long. There are 14 productive sands in the formation. The Whitmer and Lower Whitmer reservoirs near a depth of 8400 feet (2560 m) are in the Upper Wilcox Formation and are characterized by good water drives, high productivity, and good recovery. The Lilliedoll sand at a depth of 10,100 feet (3078 m) and the Frazar sand at a depth of 11,600 feet (3536 m) are in the Middle Wilcox Formation. These sands have low permeability, weak water drives, and low recovery.

##### Reservoir Performance Data

Flue gases were injected at a rate of 4 MMCFD ( $113.27 \text{ mm}^3/\text{d}$ ) and a pressure of 4500 psi (31 MPa) to displace hydrocarbon gas in the Neale Field. Corrosion problems were encountered in the injection wells. A dual string injection well serving the Lilliedoll and the Upper Spiers Sands was pulled out twice in a two year period (1966-67) because of tubing failure. The

# ATLANTIC RICHFIELD MISCIBLE FLOODS

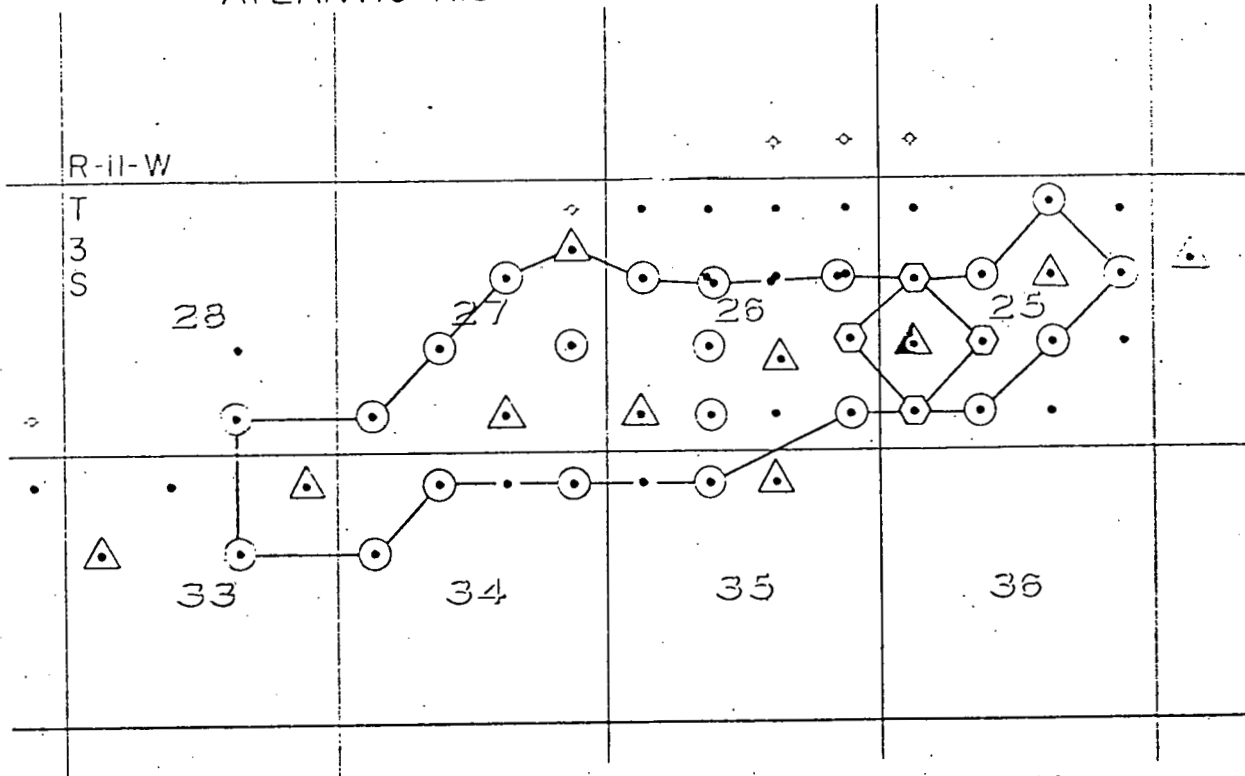

NEALE FIELD, BEAUREGARD PH, LA

- ⊙ PRODUCING WELL (LILLIEDOLL)
- ⊙ PRODUCING WELL (UPPER SPIERS)
- △ INJECTION WELL

Exhibit 4-6 Well Locations in Neale Field

Source: Ref. 4-12

pipings were internally coated and small quantities of inhibitors were injected to minimize the corrosion threat.

### Conclusions

The introduction of flue gas to an oil field injection program can result in perplexing and costly problems in the generating and compression system, in addition to problems in the field. The brief experience at Neale Field has shown that given a good basic design, and given attention to system control, it is possible to operate and maintain a relatively trouble-free flue gas plant.

#### 4.2.3 INERT GAS FLOODING IN ELK BASIN FIELD, PARK COUNTY, WYOMING AND CARBON COUNTY, MONTANA (Ref. 4-13, 4-14)

##### Location and General History

The Elk Basin Field is in the north central portion of the Big Horn Basin in Carbon County, Montana and Park County, Wyoming. The field is approximately 50 miles (80 km) east of Yellowstone Park and 200 miles (320 km) north of Casper, Wyoming. In 1915 the discovery well was completed in the Frontier Sand. Gas reserves were discovered in the Dakota Sand in 1922, the Embar-Tensleep oil reserve was discovered in 1942, and the Madison limestone oil reserve was discovered in 1946.

##### Geologic and Reservoir Fluid Data

The Elk Basin Field lies on an elongated asymmetrical anticline with the major axis trending northwest-southeast (Exhibits 4-7 and 4-8).

The two sands in the Frontier Formation range in depth from 1100 to 1700 feet (335 to 518 m) and produce 43<sup>o</sup> API oil. The Second Frontier has produced 90 percent of the Frontier oil to date. The average thickness of this sand is 50 feet (15.24 m) and it has a productive area of over 400 acres (1.6 km<sup>2</sup>).

The Dakota Formation is approximately 45 feet (13.72 m) thick and lies at an average depth of 2500 feet (760 m). It has a proven productive area of 1080 acres (4.37 km<sup>2</sup>) and, since it is nearly depleted, it is now being used as a storage facility.

The Embar-Tensleep oil reserve lies at an average depth of 4900 feet (1494 m) and has a proven productive area in excess of 6000 acres (24.28 km<sup>2</sup>). The subsurface structure includes more than 2000 feet (610m) of oil filled closures, with strata dipping at an average of 21 degrees on the west flank and 45 degrees on the east. The 30<sup>o</sup> API crude oil has a high sulfur content and was undersaturated with gas at the original pressure. At present, an

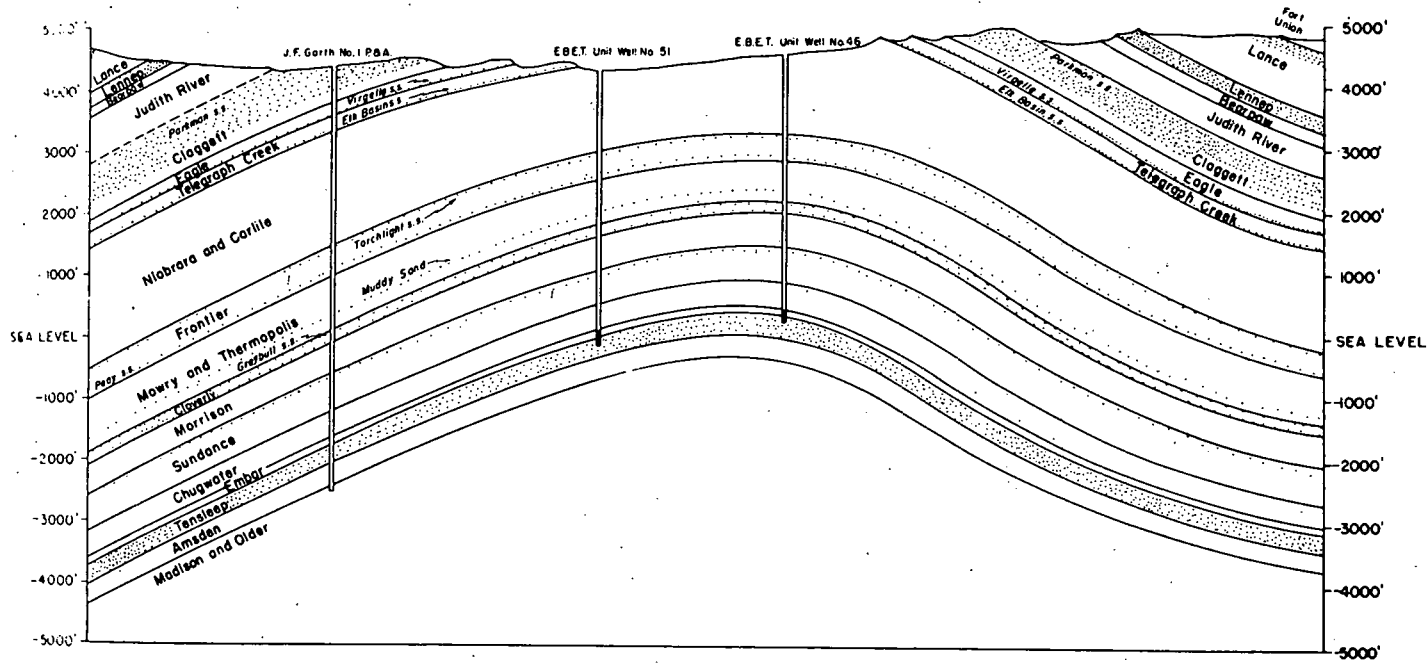

GEOLOGIC CROSS SECTION OF ELK BASIN FIELD



Exhibit 4-7 Geologic Cross Section of Elk Basin Field

Source: Ref. 4-14



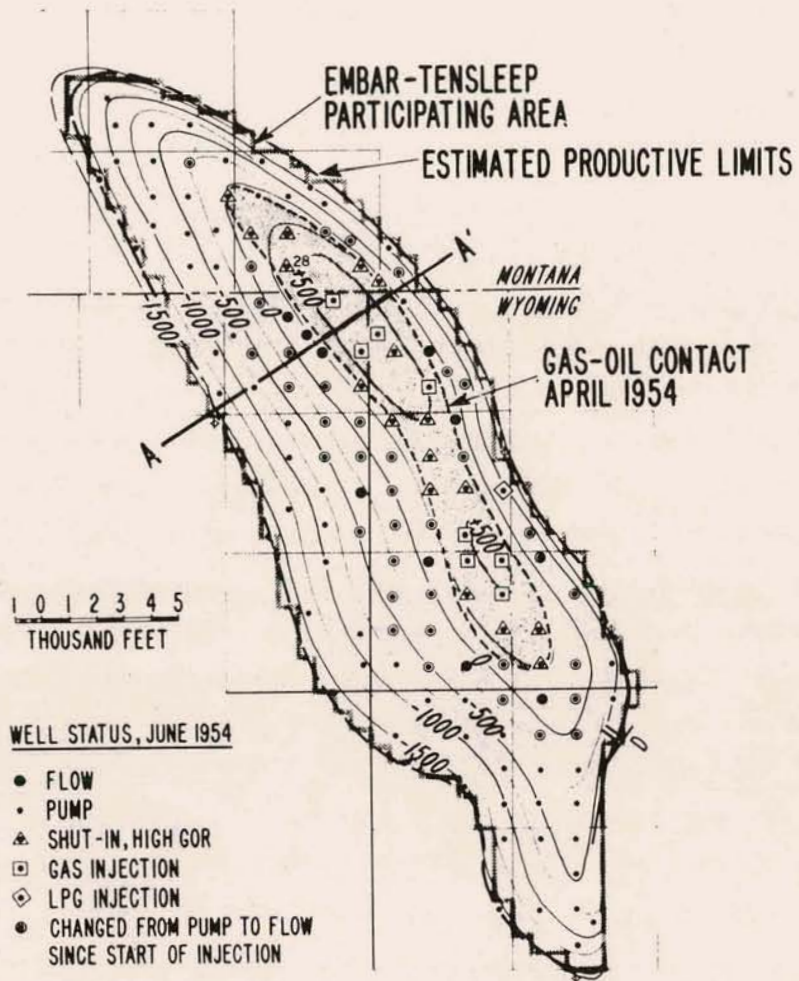

Exhibit 4-8 Sand-Top Isobars, Superimposed on Structure Map, Elk Basin Tensleep Reservoir

Source: Ref. 4-13

inert gas is generated from the produced gas and is injected into the crest of the structure.

The Mississippian age Madison Limestone is 920 feet (280 m) thick, has a productive area in excess of 5000 (20.23 km<sup>2</sup>) acres, and lies at an average depth of 5150 feet (1510 m). The 28<sup>o</sup> API crude oil has a high sulfur content, and was undersaturated at the time of recovery. An active water drive is the producing mechanism in the reservoir.

#### Reservoir Performance Data

The Embar-Tensleep producing and pressure maintenance program is one of the first projects to use inert gas successfully for maintaining reservoir pressure. Prior to the unitization, reservoir pressure was falling rapidly, even though the oil production rate was only 10,000 BOPD (1590 m<sup>3</sup>/d). With selective production following unitization, the rate of pressure decline was reduced, even though the producing rate was increased by 50 percent. The leveling of the pressure decline from the years 1946 through 1949 was attributed to shutting in high gas-oil ratio wells, and selectively producing low gas-oil wells which were producing oil down dip of the reservoir.

Since the commencement of inert gas injection, bottom hole pressure had increased approximately 100 psi, even though oil production rates were stepped up to 19000 BOPD (3020 m<sup>3</sup>/d). GORS remained near the solution GOR that would be obtained if natural gas were used. The gas-cap expanded uniformly with no channeling of injected gas.

In such processes the dominant producing mechanism is gravity segregation which should result in high recovery efficiency. The injection program results in a high producing rate from the existing wells, and allows the oil drained by gravity to be recovered with fewer producing installations.

#### 4.2.4 ACID GAS FLOODING AND N<sub>2</sub> CHASE GAS INJECTION IN SLAUGHTER FIELD, TEXAS\* (Ref. 4-1, 4-2, 4-15)

##### Location and General History

Slaughter Field, located on the North Basin Platform in Cochran, Hockley, and Terry Counties, Texas, is one of the largest fields in west Texas, having 2858 wells in a productive area of 87,150 acres (352.7 km<sup>2</sup>). Production is

\*This project is reported as a CO<sub>2</sub> flood project since acid gas injected in the field consisted of 70 percent CO<sub>2</sub>.

from the San Andres Dolomite at a depth of 4950 feet (1510 m). Discovered in 1937, it had produced 642,687,400 bbl (102.18 MMm<sup>3</sup>) of oil through 1975. Water flood operations were initiated in the Slaughter Estate Unit in 1963. The Central Mallet Unit was formed in 1964, and a pilot project using enriched gas injection is underway. Amoco is the operator of both units. Previous production was from a water flood that started with 53 percent residual oil saturation, and ended with 33 percent.

#### Geologic and Petrophysical data

The San Andres formation is in the lower Guadalupe Series of the middle Permian system, is productive over a large area of West Texas, primarily on the Central Basin Platform, the Northwest Shelf, and the North Basin Platform. It is estimated that one-half of the oil production in the Permian Basin is from Guadalupe-age reservoirs.

Slaughter Field is separated from Levelland Field by a narrow region of nonporous carbonates. It is slightly downdip of Levelland Field. Production is from porous intervals 700 to 800 feet (213 to 244 m) below the top of the San Andres formation. One or two of the four zones of porosity development usually constitute the dominant pay.

Core data indicate that the producing interval is anhydritic dolomite with no fracturing or permeability orientation. The gross pay averages a thickness of 149 feet (45.4 m) while the net pay is 89 feet (27.13 m), with an average porosity and permeability of 10 percent and 8.1 md ( $7.99 \times 10^{-3} \mu\text{m}^2$ ), respectively.

#### Reservoir Fluid Data

Slaughter Field produces essentially through solution gas drive. The original bottom hole pressure was 1710 psi (11.8 MPa); formation temperature is 104°F (60°C). The oil has a 32° API gravity, viscosity of 1.382 cp ( $1.382 \times 10^{-3} \text{ Pa}\cdot\text{s}$ ), and a formation volume factor of 1.228.

#### Acid Flood Project Data

Amoco initiated the pilot-test in the Slaughter Estate Unit in November 1972 comprising two 6.6-acre (26.7 Mm<sup>2</sup>) five-spot patterns. Water was injected into six injectors until August 1976 in order to ensure that the area had been completely watered out. Between August 76 and September 79, acid gas (30 percent H<sub>2</sub>S and 70 percent CO<sub>2</sub>) and water were injected simultaneously into different wells (i.e., water is injected in three wells, gas in three wells, and the injection is alternated). The acid gas was injected at a rate

of 27 MMCFD ( $765 \text{ MMm}^3/\text{d}$ ), which was obtained from Amoco's Slaughter gasoline plant. The acid gas injection phase was completed on September 13, 1979; the  $\text{N}_2$  chase gas injection phase was initiated on October 5, 1979. The performance plots of the two pilot producing wells and six pilot injection wells are shown in Exhibit 4-9.

#### Conclusions:

As of January 1, 1980, EOR from the pilot test was 75 STB/acre ft. ( $9.67 \times 10^{-3} \text{ m}^3/\text{m}^3$ ). It is anticipated that ultimate oil recovery due to this EOR project will be about 116 STB/acre ft. ( $14.95 \times 10^{-3} \text{ m}^3 \text{ oil}/\text{m}^3 \text{ reservoir rock}$ ).

#### 4.2.5 INERT GAS FLOODING AT IBERIA FIELD, LOUISIANA (Ref. 4-16)

Texaco, Inc. is trying to produce oil trapped in the attics (updip) of two steeply dipping reservoirs in Iberia Field, Iberia Parish, Louisiana. The target of the project is oil that is updip from the higher producing wells in the Gralino "A" Sandstone and the Bullock-Burke Sandstone (Exhibit 4-10).

#### General History

The two reservoirs scheduled for the attic recovery project were operating under a strong natural water drive, making it impossible to produce oil without forming an artificial gas-cap. The downdip wells in the Gralino "A" Sandstone were producing water with oil, while the updip wells were still producing clean oil. Experience shows that that was the best time to inject gas for updip oil recovery (i.e., before the updip wells started to produce water). This defers, and perhaps minimizes, the high lifting costs associated with high water cuts.

#### Predicted Reservoir Performance

By injecting gas updip, oil will be displaced for recovery from structurally lower wells. Texaco is conserving natural gas by displacing the oil with an inert gas mixture. The inert gas generator will produce about 1.33 MMCFD ( $.377 \text{ MMm}^3/\text{d}$ ). Recovery is expected to increase by about 10 percent.

#### 4.2.6 FLUE GAS FLOOD AT EAST BINGER FIELD, OKLAHOMA (Ref. 4-1, 4-17)

The East Binger Field, located in Caddo County, Oklahoma, was started in 1977 by Phillips Petroleum. The 12960 acre ( $42.55 \text{ km}^2$ ) field has 61 producing wells, 17 injection wells, and produces from a 27 foot (8.23 m) thick

**SLAUGHTER ESTATE UNIT  
TERTIARY PILOT**

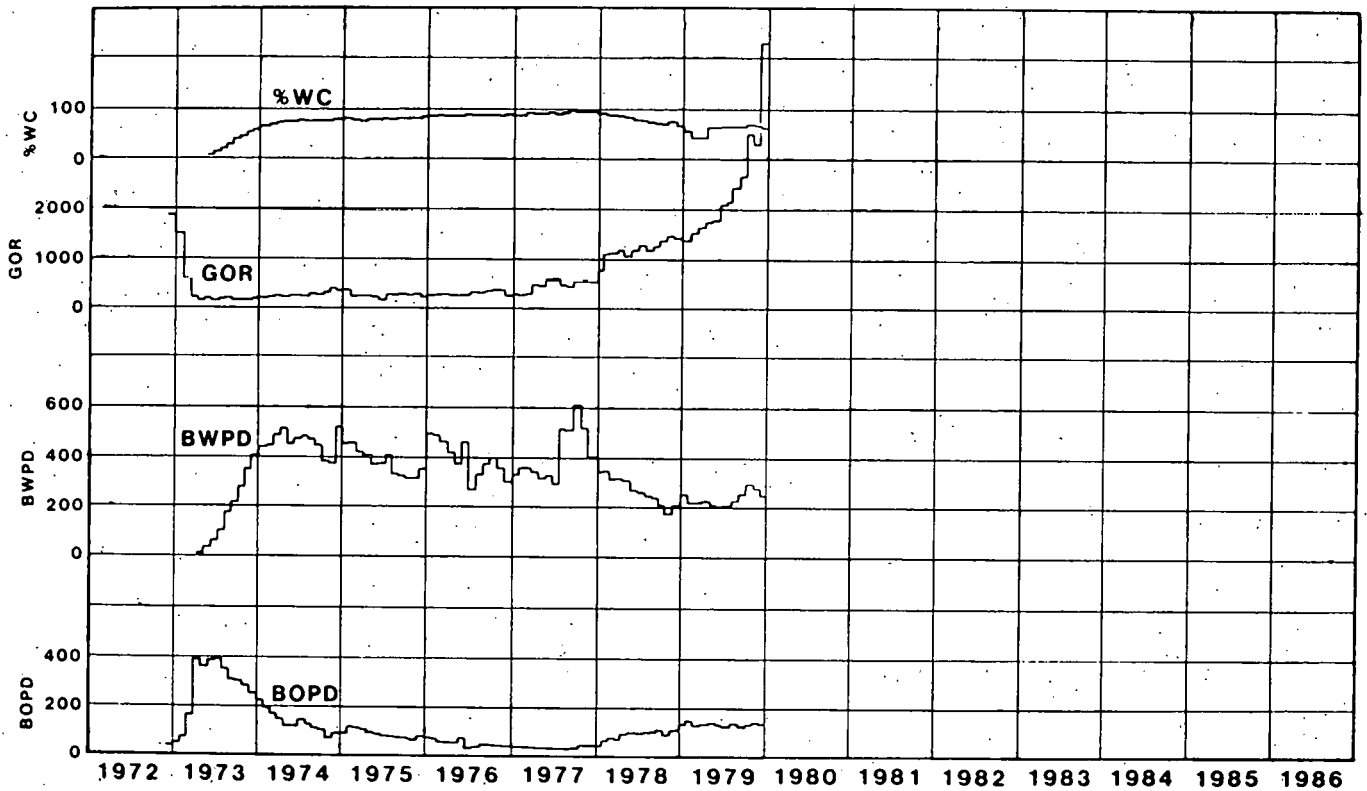

This Curve Represents the Sum of the Performance  
of 2 Pilot Producing Wells

SI Metric Conversion Factors

$$bb1 \times 1.589783 \text{ E} - 01 = m^3$$

$$GOR: SCF/bb1 \times 1.589873 \text{ E} - 01 = GOR: m^3/m^3$$

Exhibit 4-9 Performance Plots of Slaughter Estate Unit Tertiary Pilot Test

Source: Ref. 4-15

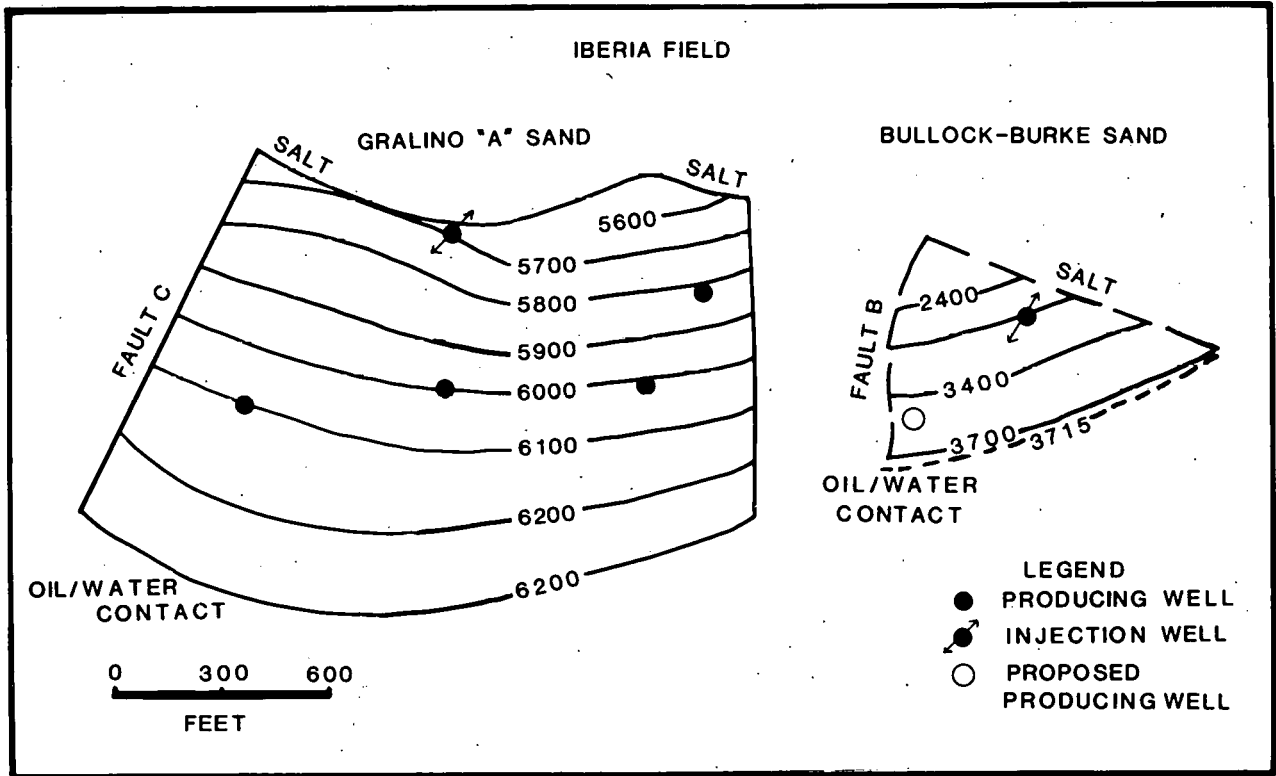

SI Metric Conversion Factors

ft. x 3.048 E - 01 = m

Exhibit 4-10 Structure Contour Map of Gralino 'A' and Bullock-Burke Sand  
Iberia Field

Source: Ref. 4-16

sandstone. It has a porosity of 7.5 percent and a permeability of 0.2 md ( $1.947 \times 10^{-4} \text{ m}^2$ ). The pay zone is at a depth of 10,000 feet (3048 m). The oil has a API gravity of  $38^\circ$ , with a viscosity of 0.3 cp ( $3 \times 10^{-4} \text{ Pa}\cdot\text{s}$ ). The reservoir temperature is  $190^\circ\text{F}$  ( $87.8^\circ\text{C}$ ).

The initial injection rate into the Marchand Sand, was 6 MMCFD (17 MM  $\text{m}^3/\text{d}$ ). With the addition of four other injection units, this rate will jump to 30 MMCFD (85 MM  $\text{m}^3/\text{d}$ ). Phillips expects production from the field to triple, boosting ultimate recovery from 16 million to 44 million bbl (2.54 to 6.99 MM  $\text{m}^3$ ). The Binger flood has experienced early breakthrough of the flue gas and expected production increase will not be obtained. Phillips will use one-third of the gas production to fuel the compressors.

#### 4.2.7 FLUE GAS FLOOD AT HAWKINS FIELD, WOOD COUNTY, TEXAS (Ref. 4-1, 4-23)

The Hawkins Field is located 20 miles (32 km) north of Tyler Texas. There are 351 production wells and 38 injection wells in the 10,590 acre ( $42.86 \text{ km}^2$ ) field. The producing formation is the Woodbine Sandstone which is at a depth of 4530 feet (1381 m). The porosity and permeability are 27.9 percent and 3400 md ( $3.36 \text{ m}^2$ ), respectively. The reservoir temperature is  $168^\circ\text{F}$  ( $75.5^\circ\text{C}$ ), and the  $24^\circ$  API oil has a viscosity of 3.7 cp ( $.0037 \text{ Pa}\cdot\text{s}$ ).

Extensive reservoir studies prior to the Hawkins Field unitization indicated a need to use a gas drive rather than a natural water drive to maximize field recovery and to minimize and then prevent residual oil loss as a result of oil movement into the gas cap, because of the gradual decline in the gas cap pressure. Because of the cost and availability of natural gas, it was decided to use steam boiler exhaust gas for pressure maintenance injection needs. The Hawkins Inert Gas Plant was designed and constructed to inject an average daily volume of 100 MMSCFD (approx. 3.40 MM  $\text{m}^3/\text{d}$ ) of boiler flue gas. The Hawkins Field project was initiated in April 1977 by Exxon Oil Co. Some start up and operating problems were initially encountered in the operation of the inert gas plant. However, the project appears to be promising.

#### 4.2.8 INERT GAS FLOODING IN THE BAYOU DES GLAISE FIELD, IBERVILLE PARISH, LOUISIANA (Ref. 4-18)

##### Location and General History

The Bayou des Glaise Field is located about 40 miles (64 km) west of Baton Rouge, Louisiana. The field lies on the flanks of a piercement salt dome.

Steeply dipping oil and gas producing sands are found at depths between 8000 and 12,000 feet (2438 and 3658 m). Individual sands are divided into separate reservoirs as a result of radial faulting.

In reservoirs of this type which have strong water-drive producing mechanisms, it is common that updip oil remains after the wells water-out. This oil is uneconomical to recover through additional drilling.

To recover attic oil at Bayou des Glaise, a secondary recovery program was initiated. This included injecting inert gas into existing wells.

#### Reservoir Performance

Inert gas injection was begun in April 1960 and continued through September 1964, with a total injection of 350 MMCF (9.91 MMm<sup>3</sup>). Although this was not a large volume, it was large enough to determine if corrosion problems existed. Most problems were mechanical and concerned either cooling water or electricity.

#### Conclusions

Humble (now Exxon) concluded that inert gas is practical for high pressure gas injection. In the 1960's inert gas use required a larger investment and higher operating expenses than natural gas. Because of these factors, the use of inert gas was restricted to fields where the natural gas supply was limited. However, with the increase in natural gas prices in recent years, inert gas should be economical. A large gas engine that drives both the gas compressor and an electric generator would provide sufficient exhaust gas for injection, and it would supply the unit's own electricity. The use of air cooling could reduce the water circulation rate by 90 percent and would practically eliminate any water problems.

#### 4.2.9 FLUE GAS FLOOD AT WEST HEIDELBERG FIELD, MISSISSIPPI (Ref. 4-19)

The Cotton Valley Unit of West Heidelberg Field is being operated by Gulf Oil Company. The West Heidelberg Field was unitized in April 1970. This EOR project was originally started as an in situ combustion project. Compressed air was injected, beginning in December 1971. In May 1977 flue gas was added to the air injection in Cotton Valley No. 5 Sand. Flue gas injection was started in the Cotton Valley No. 4 sand in June 1978. The performance plot of the Cotton Valley No. 4 sand flue gas project is shown in Exhibit 4-11.



GULF OIL COMPANY-U.S.  
 PERFORMANCE CURVE  
**WEST HEIDELBERG COTTON VALLEY UNIT**  
 COTTON VALLEY NO.5 SAND  
 HEIDELBERG FIELD  
 JASPER CO., MISS.

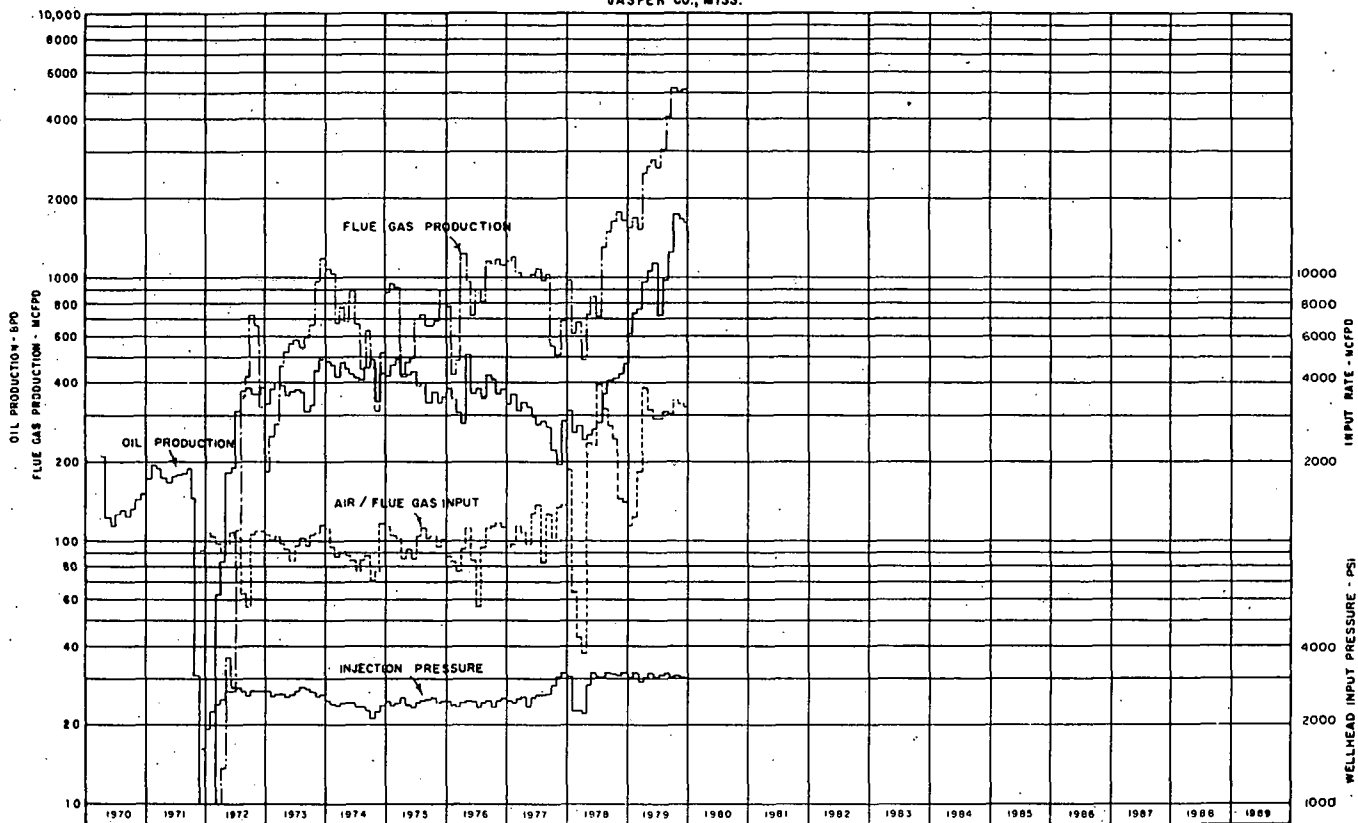

SI Metric Conversion Factors

psi x 6.894757 E - 03 = MPa

ft<sup>3</sup> x 7.831685 E - 02 = m<sup>3</sup>

bbls x 1.589873 E - 01 = m<sup>3</sup>

Exhibit 4-11 Performance Curve of West Heidelberg Cotton Valley Unit

Source: Ref. 4-19

#### 4.2.10 EXHAUST GAS INJECTION IN WEIR SAND OF MINGO COUNTY, WEST VIRGINIA (Ref. 4-22)

Exhaust gas generated from an engine was injected in the Weir Sand of Mingo County, West Virginia by Wieser Oil Company in 1969. The formation had a porosity and a permeability of 14 to 16 percent and less than 1 md ( $.001 \text{ m}^2$ ), respectively. The residual oil saturation was 35 to 40 percent. The exhaust gas was injected for six months. It was not economical, and the project was aborted.

### 4.3 AIR INJECTION

When air is injected in a warm reservoir, the oxygen content of the air will react with the oil if spontaneous combustion occurs. This will produce  $\text{CO}_2$  which will dissolve in the oil.  $\text{N}_2$  will act as a piercing gas and thus, additional oil may be recovered. Air is much cheaper to use than any other gas as only compression and injection costs are involved.

The use of air injection in EOR has been attempted at Willow Draw Field by Oil Services Company, with sponsorship from the U. S. Department of Energy.

#### 4.3.1 ATTIC AIR INJECTION, WILLOW DRAW FIELD, WYOMING (Ref. 4-1, 4-2, 4-21) Reservoir Data

Willow Draw Field is located in Park County, Wyoming. It lies on 400 acres ( $1.62 \text{ km}^2$ ), and has ten producing and two injection wells. The pay zones are the Dinwoody, Phosphoria, and Tensleep Formations which are primarily limestone at a depth of 4400 feet (1341 m) (Exhibit 4-12). The average porosity and permeability are 10.6 percent and 20 md ( $.02 \mu\text{m}^2$ ), respectively. The reservoir oil is  $16^{\circ}$  API and has a viscosity of 37 cp ( $.037 \text{ Pa}\cdot\text{s}$ ). The reservoir temperature is  $146^{\circ}\text{F}$  ( $63.3^{\circ}\text{C}$ ).

#### Predicted Reservoir Performance

This project will demonstrate the technical and economic feasibility of oil recovery from a low productivity reservoir using the attic air injection process. The project is expected to increase the ultimate recovery from one to four percent of the OOIP. Air is injected into the upper portion of the oil reservoir in order to displace the attic or updip oil downward, to replace the produced oil and maintain reservoir pressure, thereby preventing water influx from below the oil zone. Plots of the oil and water production are shown in Exhibit 4-13.

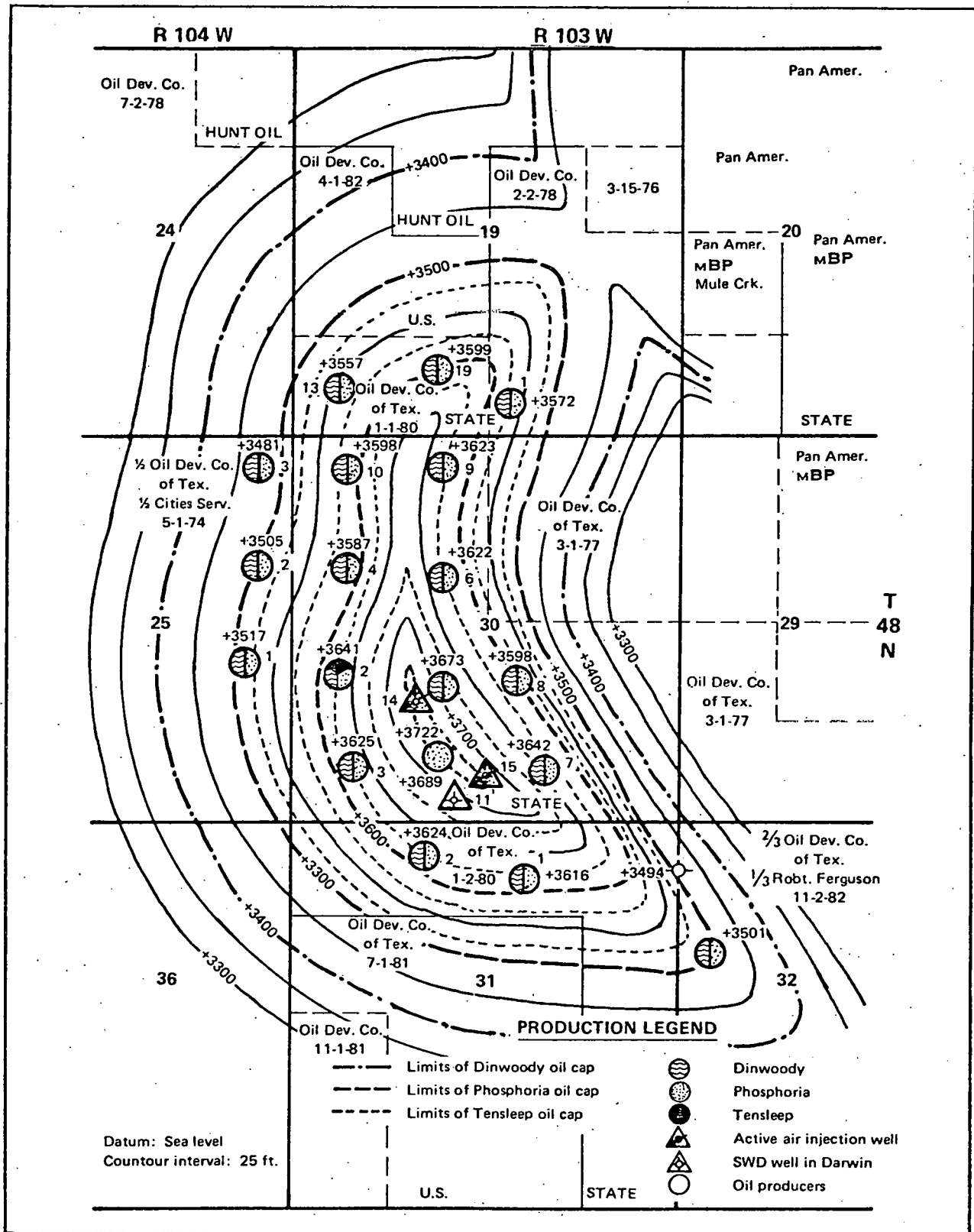
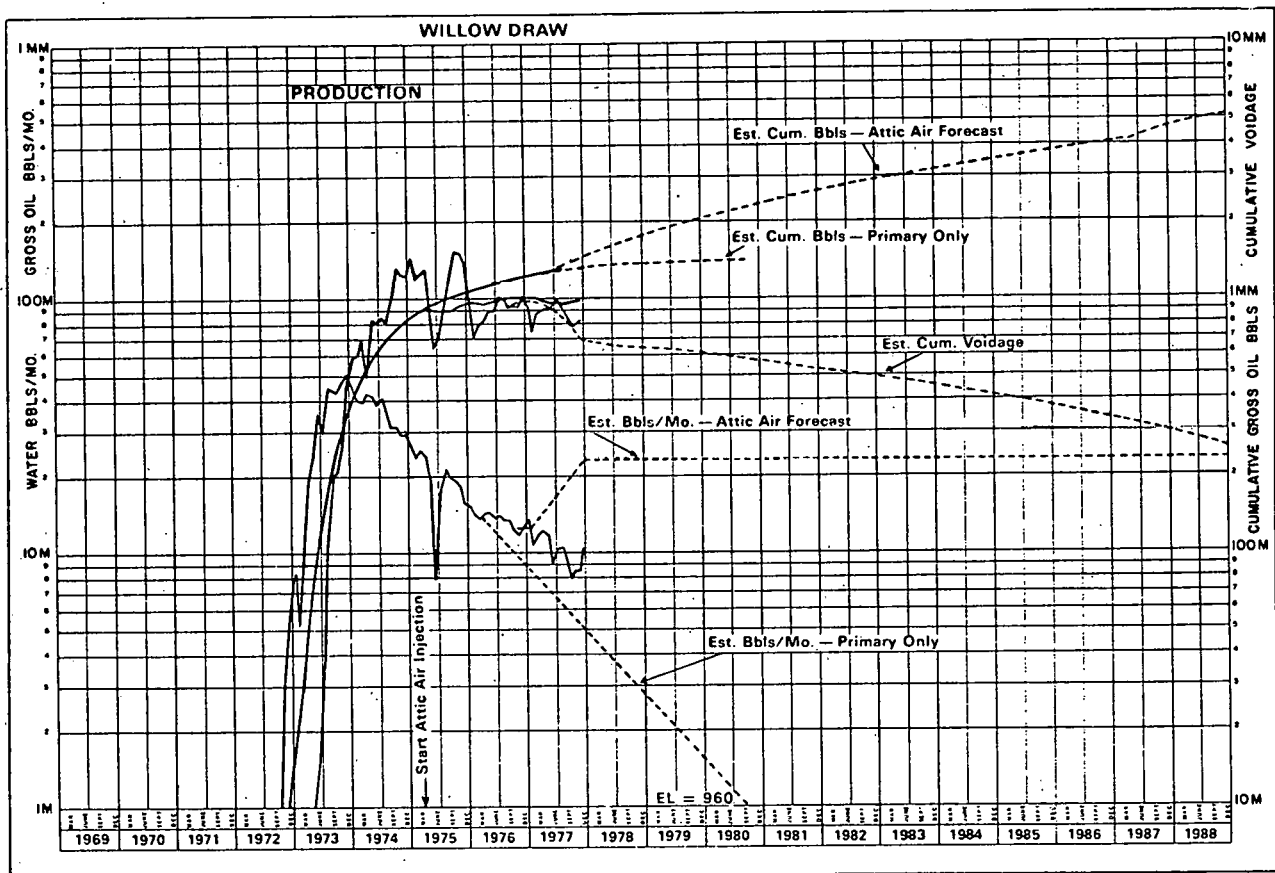

Exhibit 4-12 Structure Map of Willow Draw Field, Park Co., Wyoming

Source: Ref. 4-20



SI Metric Conversion Factor

$$\text{bbl} \times 1.589873 \text{ E} - 01 = \text{m}^3$$

Exhibit 4-13 Oil and Water Production, Willow Draw Field, Wyoming

Source: Ref. 4-20

Air injection was started on December 14, 1976. Adverse weather conditions and mechanical failures caused some delays. Air is injected at 183 MCFD ( $5.18 \text{ Mm}^3$ ), or 2.6 times the current oil withdrawal rate. Cumulative air injection is 20 percent of the cumulative oil production. Air breakthrough occurred in October 1977. Nine wells were recompleted, and air injection was restarted in December 1977. In January 1978, the air compressor was destroyed due to fire. Injection was halted until August 1978 when the new compressor arrived. By December 1978, all primary oil had been produced. Henceforth, all oil production if any will be through EOR methods, and approximately 3.5 STB of oil/acre ft. of reservoir rock ( $4.51 \times 10^{-4} \text{ m}^3/\text{m}^3$ ) is expected to be produced if the project continues.

## References

- 4-1 Matheny, Shannon L., "EOR Methods Help Ultimate Recovery", Oil and Gas Journal, March 31, 1980, p. 79-124.
- 4-2 Anonymous, "Pressure Maintenance Job Uses Nitrogen", Oil and Gas Journal, February 21, 1977, p. 36-37.
- 4-3 Anonymous, "Enhanced Recovery", International Petroleum Encyclopedia, 1979, p. 262-263.
- 4-4 Clavin, James W., and John L. Vogel, "An Evaluation of Nitrogen Injection As a Method of Increasing Gas Cap Reserves and Accelerating Depletion-Ryckman Creek Field, Uinta County, Wyoming," SPE 8384, 1979.
- 4-5 Peterson, A. V., "Optimal Recovery Experiments with N<sub>2</sub> and CO<sub>2</sub>," Petroleum Engineer International, November 1978, p. 40-50.
- 4-6 Greenwalt, Wayne A., "A Field Test of Nitrogen WAG Injectivity," SPE 8816, First Joint SPE/DOE Symposium on Enhanced Oil Recovery, Tulsa, Oklahoma, April 20-23, 1980.
- 4-7 Warner, H. R., Jr., J. H. Hardy, N. Robertson, and A. L. Barnes, "University Block 31 Field Study: Part 1 - Middle Devonian Reservoir History Match," Journal of Petroleum Technology, August 1979, p. 962-970.
- 4-8 Warner, H. R., C. D. Davidson, and J. H. Hardy, "University Block 31 Field Study: Part 2 - Reservoir and Gas Plant Performance Predictions", Journal of Petroleum Technology, August 1979, p. 971-978.
- 4-9 Anonymous, "Flue Gas Injection Underway in West Texas Block 31 Field," Petroleum Equipment and Services, January-February 1967, p. 45-50.
- 4-10 Hardy, J. H., and N. Robertson, "Miscible Displacement by High Pressure Gas at Block 31," Petroleum Engineer, November 1975, p. 24-28.
- 4-11 Caraway, G. E. Jr., and L. L. Lowrey, "Generating Flue Gas for Injection Releases Sales Gas," Oil and Gas Journal, July 18, 1975, p. 126-132.
- 4-12 Tittle, Robert M., et al., "Success of Flue Gas Program at Neale Field," SPE 1907, 42nd Annual Fall Meeting of SPE of AIME, Houston, Texas, October 1-4, 1967.
- 4-13 Steward, F. M., D. L. Garthwaite, and F. K. Krebill, "Pressure Maintenance by Inert Gas Injection in the High Relief, Elk-Basin Field," Petroleum Transactions AIME, V. 204, 1955, p. 49-55.
- 4-14 Harvey, R. J., and F. K. Krebill, "Elk Basin - The Cinderella Field," Petroleum Engineer, February 1954, p. A37-A48.
- 4-15 Anonymous, "EOR Update Report No. 75-12-4/79, Slaughter Field, Slaughter Estate Unit in Acre Pilot, Amoco Production Co., Hockley County, Texas," EOR Field Reports SPE/AIME, V. 5, No. 4, March 1980, p. 617-620.

- 4-16 Anonymous, "Texaco Exploits Reservoir Attics," Oil and Gas Journal, June 14, 1971, p. 75.
- 4-17 Anonymous, "Oklahoma Field Gets Flue-Gas Injection," Oil and Gas Journal, September 12, 1977, p. 54.
- 4-18 Godbold, A. S., "Humble Recovers Attic Oil with Unique Inert Gas System," World Oil, May 1965, p. 151-154.
- 4-19 Anonymous, "EOR Update Report No. 75-25-1/79, West Heidelberg Field, Cotton Valley Unit, Gulf Oil Exploration and Production Co., Jasper County, Miss." EOR Field Reports, SPE/AIME, V. 5, No. 4, March 1980.
- 4-20 Linville, William, Editor, "Attic Air Injection, Willow Draw Field, Wyoming," Enhanced Oil and Gas Recovery and Improved Drilling Methods, Quarterly Progress Report, No. 13, Bartlesville Energy Technology Center, December 31, 1977, p. 76-79.
- 4-21 Anonymous, "Willow Draw," Enhanced Oil Recovery Field Reports, SPE/AIME, June 1979, p. 141-142.
- 4-22 LaRue, C., Weiser Oil Company Company, Personal Communications, January 1980.
- 4-23 Kuehm, Harold G., "Hawkins Inert Gas Plant; Design and Early Operation," SPE 6793, 52nd Annual Fall Technical Conference of SPE/AIME, Denver, Colorado, October 9-12, 1977.

## 5.0 SOURCE, SUPPLY AND COST DATA FOR UTILIZING NITROGEN AND FLUE GAS IN EOR OPERATIONS

In order to promote the commercial acceptance and widespread use of nitrogen and flue gas in EOR, their availability and costs of production and use must be evaluated. A thorough cost analysis is beyond the scope of this Task. However, available information suggests that successful recoveries may be achieved with lower costs using nitrogen or flue gas injection than using CO<sub>2</sub> or hydrocarbon gas injection.

Although inadequate information is available on the relative economics of nitrogen and flue gas injection EOR operations, a generic comparison of cost components in different production scenarios is presented, based on data obtained from selected literature.

Cost ranges for four basic recovery alternatives are presented and compared:

1. On site production and utilization of N<sub>2</sub> for use in nitrogen injection operations assuming nitrogen production and rejection facilities are owned by the field operator or service contractor (see Section 5.1).
2. On site production and utilization of flue gas for use in injection operations assuming the flue gas is generated in an on-site plant (boiler flue gas) owned by the field operator (see Section 5.2).
3. Production and utilization of flue gas produced as exhaust (engine exhaust gas) from diesel or other on site engines (see Section 5.2).
4. Utilization of flue gas recovered in an electric utility and transported to the reservoir by pipeline for use in injection operations (see Section 5.2).

All cost estimates are preliminary in nature and are drawn primarily from the literature. When possible, data were collected and/or verified through communication with industry sources.

### 5.1 AVAILABILITY AND COST OF NITROGEN

The production of nitrogen through cryogenic separation of air components has been in use since the early part of this century and constitutes a flexible and economical method for producing large quantities of pure nitrogen. Nitrogen can be produced by other methods such as the burning of



the oxygen from air using a carbon source, and then removing CO<sub>2</sub> by absorption. Such a gas will not be as pure as the nitrogen from the cryogenic separation of air. Cryogenic nitrogen plants for nitrogen provide a flexible source because the generation process depends on a readily available source (air) whose supply is unlimited.

The fundamental concept in nitrogen generation is to cool air to its liquefaction temperature and then distill it. To provide low temperatures, a refrigeration cycle is used, typically consisting of the following: air compressor, heat exchangers, and an expansion turbine. The distillation column makes up the fourth major component of the cycle. Centrifugal or reciprocating compressors are used to compress the nitrogen to injection pressure. Cryogenic nitrogen plants are typically powered by electricity, natural, gas or diesel fuel. A schematic representation of the cryogenic nitrogen process is presented in Exhibit 5-1.

The costs of nitrogen generation exhibit a wide range because of the sensitivity of process economics to the following parameters:

- Plant capacity
- Energy costs per unit of output
- Project duration
- Injection pressure
- Plant location
- Reservoir characteristics
- Plant complexity
- Process reliability

Technical risk or the current expense of venture capital increase is also a factor in the "uncertain" economics of production.

The costs of nitrogen as used in EOR processes are aptly discussed in an article by Keith Wilson (Ref. 5-2). The fixed cost (1978 dollars) component of a cryogenic nitrogen\* generation process based on a 10 year project life

\*The term cryogenic nitrogen used in this report only indicates that the nitrogen is produced by the cryogenic separation of air.

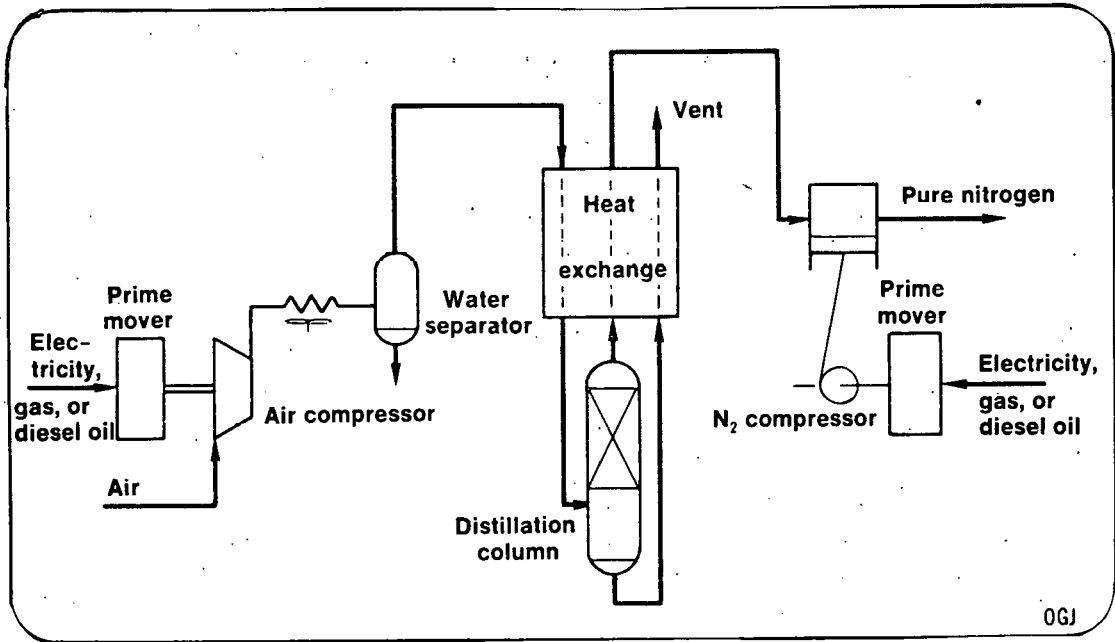

Exhibit 5-1 Schematic Diagram of Cryogenic Process for Nitrogen Production

Source: Ref. 5-2

and a delivery pressure of 3000 psig (20.7 MPa) is shown in Exhibit 5-2. It is assumed that the nitrogen facility is electrically driven. Cryogenic nitrogen plant sizes typically range from 1 MMSCFD (.283 million m<sup>3</sup>/d) to more than 100 MMSCFD (28.31 million m<sup>3</sup>/d) The fixed costs per unit of production capacity are higher in smaller plants but steadily decrease in an exponential manner in plant sizes greater than 60 MMSCFD (1.7 million m<sup>3</sup>/d).

The capital costs for a 25 MMCFD (.7 million m<sup>3</sup>/d) N<sub>2</sub> generation plant built on the Gulf Coast would probably exhibit a cost range of \$10 to 15 million. Investment costs would typically be broken down as follows (Ref. 5-9):

	<u>Percentage</u>
Air compressor	10
2,500 psig (17.24 MPa) N <sub>2</sub> Compressor)	16
Warm Process Equipment	5
Cold Equipment	20
Off Sites (utilities)	5
Buildings	2
Miscellaneous	4
Subtotal	<u>62</u>
Engineering	9
Construction	25
Start-up (and spares)	4
Subtotal	<u>38</u>

The costs of the energy necessary to produce and compress the nitrogen will frequently exceed fixed costs. The large nitrogen generators usually used for injection application require about 14.5 HP-HR/MCF (1.375 MJ/m<sup>3</sup>) to produce 3000 psig (20.7 MPa) nitrogen. Using a gas engine conversion rate of 8,000 Btu/HP-HR (3145 W/KW) this corresponds to 116,000 Btu/MCF (4.322 MJ/m<sup>3</sup>). If electric motors are used, about 11.2 kwh/MCF will be needed. Assuming a gas fired utility with an energy conversion rate of 10,000 Btu/kwh and moderate transmission losses, energy consumption will equal 117,900 Btu/MCF (4.393 MJ/m<sup>3</sup>). Energy costs, as a function of the unit price of electricity are shown in Exhibit 5-3.

The summation of the fixed costs (Exhibit 5-2) and energy costs (Exhibit 5-3) roughly approximate the total costs/MCF of different sized nitrogen injection operations subject to the process and project parameters described

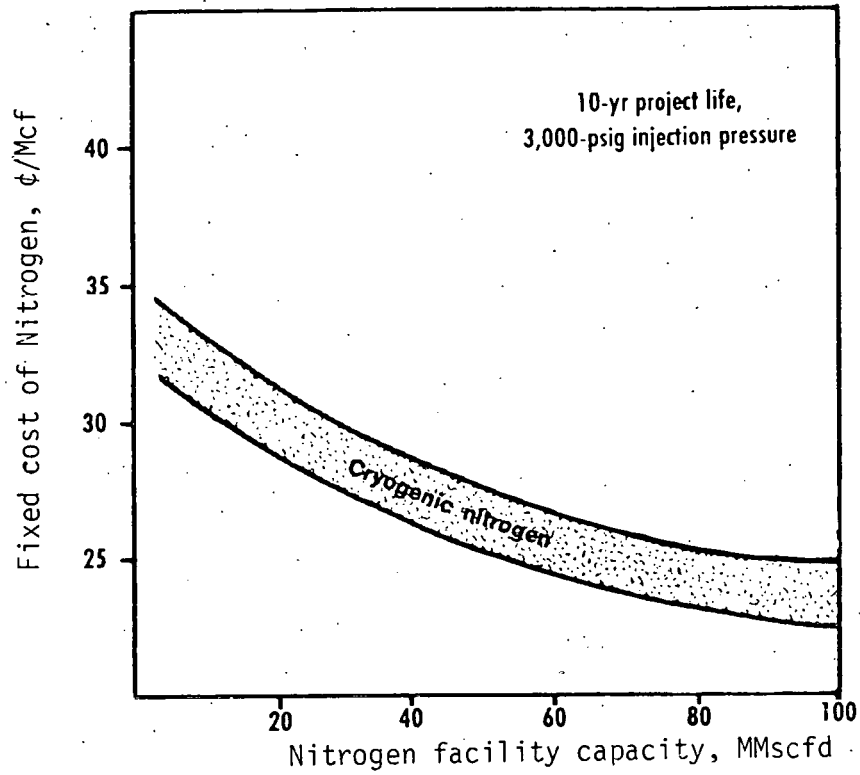

SI Metric Conversion Factors

psi x 6.894757 E - 03 = MPa

SCF x 2.831685 E - 02 = m<sup>3</sup>

Exhibit 5-2 Fixed Cost - Nitrogen Generation

Source: Ref. 5-2

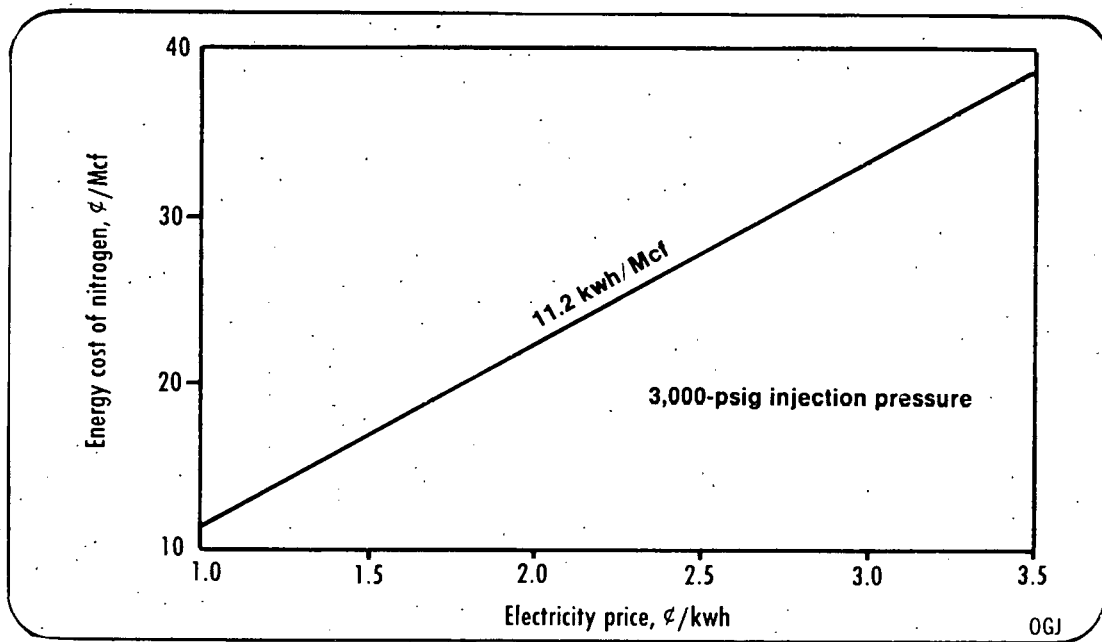

SI Metric Conversion Factors

cu. ft. x 2.831685 E - 02 = m<sup>3</sup>

psi x 6.894757 E - 03 = MPa

Exhibit 5-3 Energy Cost - Nitrogen Generation

Source: Ref. 5-2

above. For example, total costs (1978 dollars) for a 40 MMCFD ( $1.133 \text{ MM m}^3/\text{D}$ ) nitrogen injection operation of 10 years duration utilizing an injection pressure of 3000 psig (20.7 MPa) and electricity valued at 2 cents/kwh is shown to range from 48 cents/MCF ( $1.7 \text{ cents/m}^3$ ) to 51 cents/MCF ( $1.8 \text{ cents/m}^3$ ).

Indeed, industry reports  $\text{N}_2$  injection costs precisely in this range. Costs of 50 cents/MCF ( $1.765 \text{ cents m}^3$ ) are reported (Ref. 5-8) for:

- Chevron's 44 MMCFD ( $1.25 \text{ MM m}^3/\text{d}$ ) electrically driven  $\text{N}_2$  injection facility in Painter Reservoir, Wyoming.
- Sun Oil's 6 MMCFD ( $170 \text{ M m}^3/\text{d}$ )  $\text{N}_2$  injection facility in Fardoche Field, Louisiana.

Since the costs of nitrogen generating equipment and supporting apparatus are high, it is more economical in some cases for an operator to purchase nitrogen from a supplier in order to avoid the initial capital outlay. Charles Donohoe and Robert Buchanan have evaluated the economics of leasing nitrogen injection operations to maintain pressure in gas condensate reservoirs exhibiting losses through retrograde condensation (Ref. 5-1). The potential use of nitrogen in such operations is important because the current value of natural gas and its relative shortage of supply has made its use to maintain pressure in a gas condensate reservoir uneconomical. The economic analysis showed that reservoirs with fluid systems with liquid content between 65 and 96 bbl/MMCF ( $365 \text{ and } 540 \text{ m}^3 \text{ liquid/MM m}^3 \text{ gas}$ ) responded to nitrogen injection economically - generating a net income greater than pressure depletion and/or residue gas cycling techniques. The economic analyses assumed costs for purchase of  $\text{N}_2$  in a leasing agreement covering a 33 MMSCFD ( $0.934 \text{ MM m}^3/\text{d}$ ) all electric plant. Exhibit 5-4 shows the cost breakdown (in 1978 dollars) by cost component in this leasing arrangement. As shown, total costs of injection were estimated to be 49 cents/MCF ( $1.73 \text{ cents /m}^3$ ). It was assumed that the leased facility ran at 100 percent capacity and produced 99.99 percent  $\text{N}_2$  with all water vapor removed. The injection pressure was 5000 psig (34.47 MPa).

The attractiveness of purchasing nitrogen from suppliers is, of course, a direct function of the financial position of the operator, the potential duration and production level of the recovery project, and capital costs. However, purchasing nitrogen from a supplier is a realistic alternative that should be considered in the economic evaluation of any injection operation. This is indicated in the following quotation (Ref. 5-5):

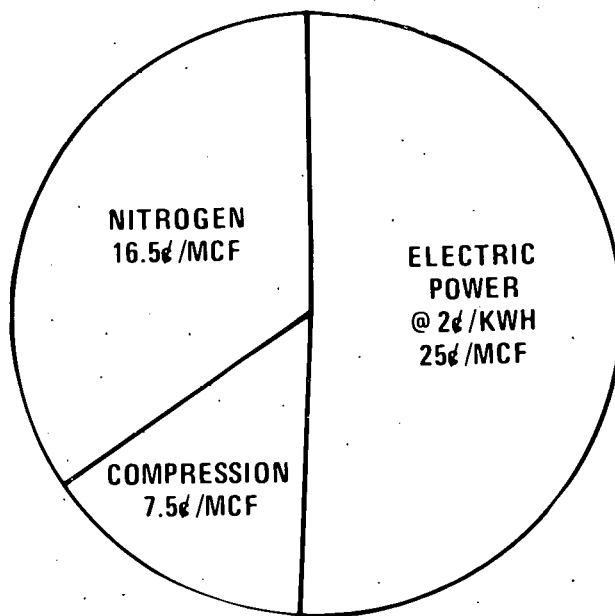

SI Metric Conversion Factors

$$\text{cu. ft.} \times 2.831685 \text{ E} - 02 = \text{m}^3$$

Exhibit 5-4 Typical Cost Component of Nitrogen

Source: Ref. 5-1

"Price: Nitrogen will be purchased on a contract basis at the required 2750 psi (19 MPa) injection pressure from a cryogenic plant being built in the field. Overall cost, including manufacturing, compression and power cost, will be approximately 40 cents per MCF (28.3 m<sup>3</sup>) injected. This amounts to 29 cents per MCF (28.3 m<sup>3</sup>) of hydrocarbon gas produced, because of the favorable nitrogen formation volume factors mentioned earlier.

Estimated costs for other gases considered were 55 cents per injected MCF (28.3 m<sup>3</sup>) for flue gas, \$1.00 - 1.25 per MCF (28.3 m<sup>3</sup>) for CO<sub>2</sub> and approximately \$2.00 per MCF (28.3 m<sup>3</sup>) for makeup hydrocarbon gas if it had been desirable to only cycle the gas cap for NGL\* and condensate recovery".

The value of leasing for small operators is apparent in the following cost approximation for a 1 MMCFD (283,100 m<sup>3</sup>/d) electrically driven nitrogen injection facility provided by AIRCO, a nitrogen supply company. The main facilities included in the cost approximation were:

- Cold box (cryogenic unit)
- Compressors (3500 psia or 24.13 MPa)
- Standby storage tanks (6000 gallons or 22.71 m<sup>3</sup>)
- Vaporizer

The costing assumed a 10 year agreement where the monthly facility fee was \$35,000. The power requirement of the plant including compression was estimated to be approximately 2700 kwh. Assuming the price of electricity to be \$.0414/kwh, the total costs of nitrogen injection were calculated to be \$.38/MCF (1.342 cents/m<sup>3</sup>).

Having approximated the general cost range of nitrogen injection, the costs of actual recovery remain to be considered. Since CO<sub>2</sub> and water content in cryogenic nitrogen is virtually non-existent, there are no costs connected with pollution or corrosion control. However, there will frequently be costs for a nitrogen rejection plant to recover gases such as methane and butane and, in some cases, to recycle the nitrogen. The costs of such a rejection plant vary widely and are very hard to estimate. The cost of rejection plant

\*Natural Gas Liquids



as a component of total injection and recovery costs is estimated to be between 5 and 40 cents/MCF (28.32 m<sup>3</sup>). This large variation is a result of the following factors:

- Feed composition of gas - a CO<sub>2</sub> component can greatly increase costs.
- Feed gas pressure.
- Rejection facility must usually be integrated with other gas processing facilities.
- Energy cost to power the rejection facility.
- Composition of recovered gas frequently changes during the life of the project, thus, changing the rejection plants requirements and costs.

In order to provide a rough estimate of capital investment expense, the costs for a 25 MMSCFD (0.71 MM m<sup>3</sup>/d) nitrogen rejection plant are approximated below. Costs are for a plant built on the Gulf Coast that will accept a feed of produced gas containing 5-50 percent N<sub>2</sub> and 1.5 percent CO<sub>2</sub>. The feed pressure of the recovered gas is assumed to be 800 psig (5.5 MPa) while the product pressure is considered to be 1000 psig (6.9 MPa). Total capital investment for the plant is estimated to range from \$12 to \$20 million (Ref. 5-9). The cost components are:

	<u>Percentage</u>
MEA Unit	15
Molecular Sieve Unit	15
Natural Gas Liquid (NGL) Plant	25
Cold Box	30
Compression	15
Total	<u>100</u>

As previously stated, total costs may vary significantly for plants of similar size. For example, if there were no CO<sub>2</sub> in the gas, MEA would not be needed and the costs of the molecular sieve unit would be much lower. If the feed and product pressures were different, compression costs could change by a factor of two in either direction. Similarly, costs for the NGL facility are widely variable depending on the specifications for liquid recovery and the degree of separation. Finally, details of site location can affect all of these costs.

## 5.2 AVAILABILITY AND COST OF FLUE GASES

Alternate sources of flue gases for use in EOR operations are:

- Generation of flue gas from combustion or incineration of lean gas or other fuel in the boiler (boiler gas) built on the site of the recovery operation.
- Generation of flue gas (exhaust gas) from diesel and/or other engines on site of the recovery operation.
- Generation of flue gas from an electric utility (or other industrial source) and pipelining of that flue gas to the site of the recovery operation.

This Section attempts to evaluate the economics of the these generation processes that are potentially useful in EOR operations.

An article by Keith Wilson (Ref. 5-2) is very useful in assessing the costs of boiler and exhaust gas operations. Exhaust gas and boiler gas systems (Exhibits 5-5 and 5-6) are similar in design but differ in components and in size of operation. The former utilizes the exhaust from diesel and/or other on-site engines as energy sources, while the boiler gas system requires the installation of a combustion chamber to generate the inert gas used in recovery operations. Both processes generate flue gas through the combustion of such products as natural gas, coal, diesel fuel, or gasoline. The sources of such raw materials are, of course, less reliable than air required for the cryogenic nitrogen generation. However, sources of fuel gas are generally more sensitive to economic considerations than to an actually limited supply.

Exhibit 5-7 displays ranges of fixed costs that operators of various sized flue gas operations could expect to incur. Costs are in 1978 dollars and assume a delivery pressure of 3000 psig (20.7 MPa) and a project duration of ten years. Because of the differences in system design and expense, boiler gas is probably impractical in operations that utilize less than 30 MMSCFD (.85 MM m<sup>3</sup>/d), while the largest practical gas engine exhaust train is efficient for less than 10 MMSCFD (.2832 MM m<sup>3</sup>/d). Both systems require that the gas stream be dried before injection into the reservoir in order to control the corrosive nature of the gas oxide components. However, once the gas is injected into the reservoir, it may come into contact with water, thus, potentially revitalizing its corrosive components and subjecting production wells to problems of CO<sub>2</sub> and NO<sub>x</sub> corrosion. Corrosion problems may be greatly

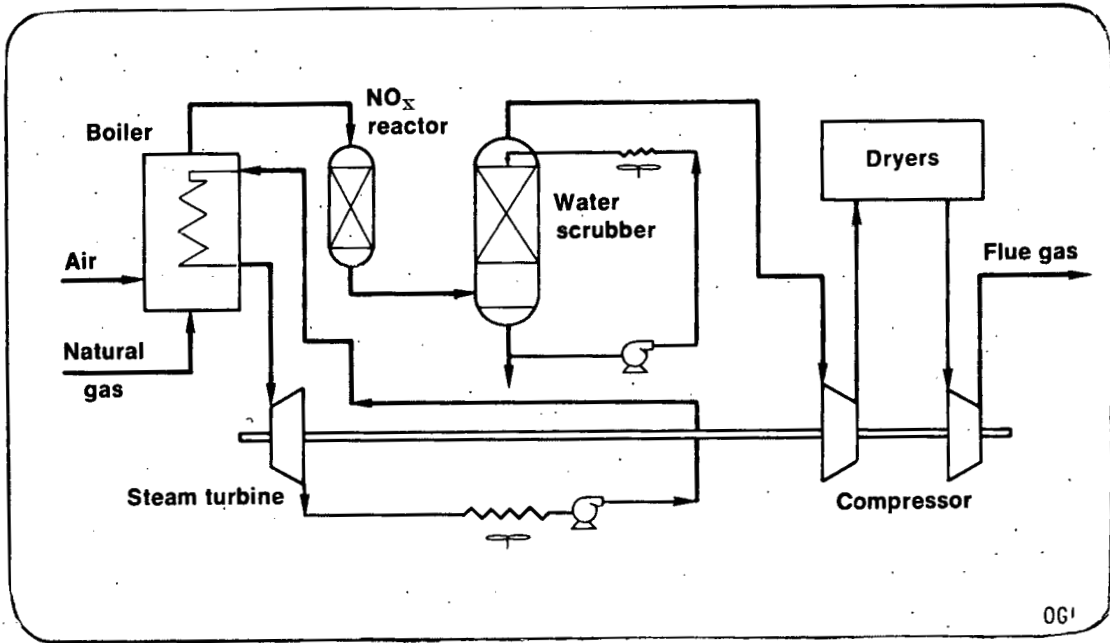

Exhibit 5-5 Schematic Diagram of Flue Gas (Boiler Gas) Generation Process

Source: Ref. 5-2

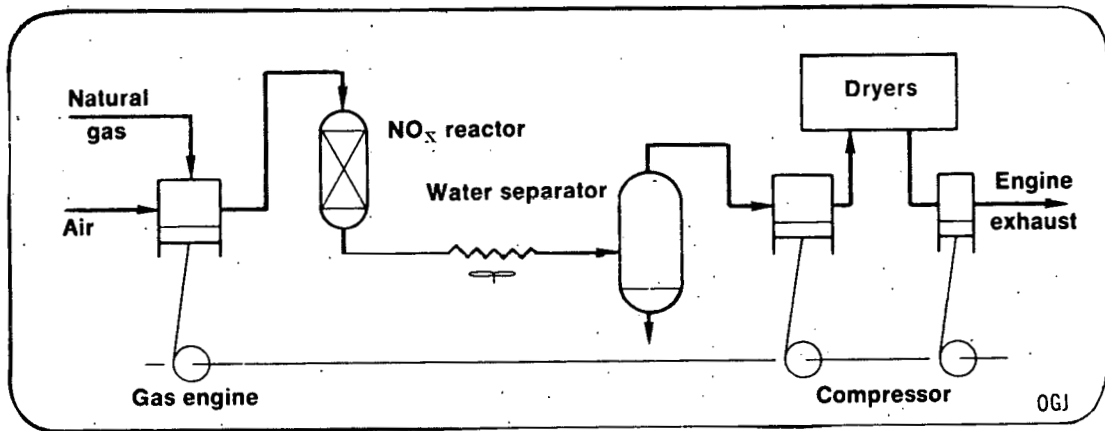
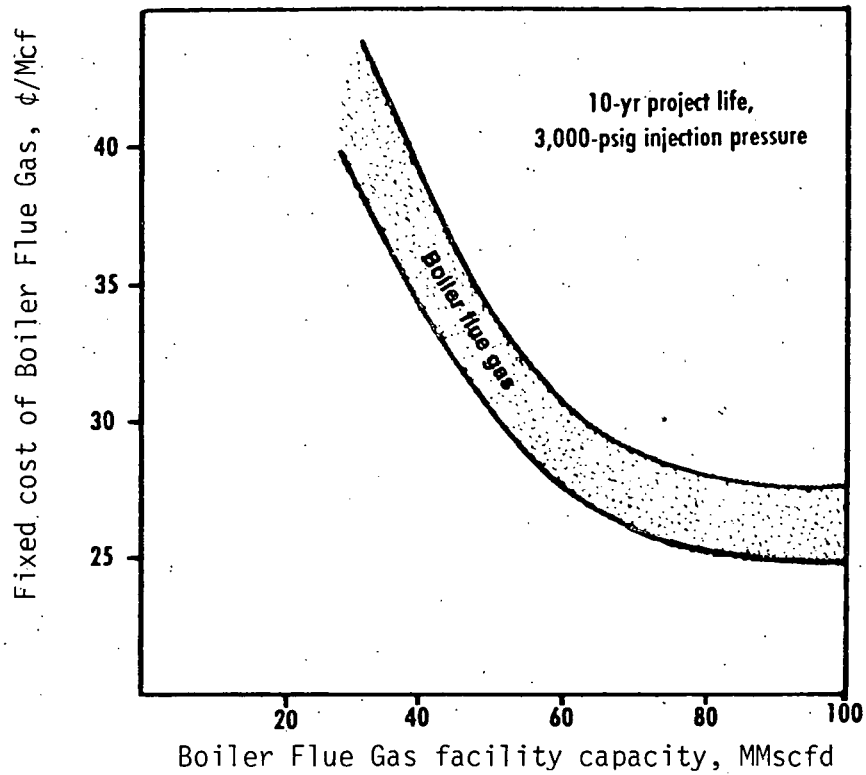

Exhibit 5-6 Schematic Diagram of Flue Gas (Engine Exhaust Gas) Generation Process

Source: Ref. 5-2



SI Metric Conversion Factors

psi x 6.894757 E - 03 = MPa

SCF x 2.831685 E - 02 = m<sup>3</sup>

Exhibit 5-7 Fixed Cost - Boiler Flue Gas Generation

Source: Ref. 5-2

exacerbated if equipment malfunctions allow the presence of liquid in the injection phase. In addition, the use of some fuels as an energy source may require environmental control systems in order to satisfy ambient air quality standards.

The costs of the energy used to generate flue gas will frequently exceed the fixed costs of the flue gas process. Exhibit 5-8 estimates the approximate energy costs of flue gas injection as a function of the unit price of natural gas burned. An injection pressure of 3000 psig (20.7 MPa) is assumed. The costs of natural gas can serve as a rough approximation of energy costs assuming the use of alternative fuels such as diesel or gasoline. Note that flue gas plants (boiler) have inert gas to fuel ratios of 5.5 or 6 to one (based on the experience of ARCO's Block 31 and Exxon's Hawkins operations). Compared to the 8.5 to one ratio common for cryogenic injection operations, the boiler flue gas process is a very inefficient converter of energy. The range of total flue gas injection costs for both boiler and exhaust gas operations can be approximated by adding the fixed costs (Exhibit 5-7) and energy costs (Exhibit 5-8) for any size facility. Assuming a natural gas price of \$2.50/million Btu the total injection costs for a 40 MMSCFD (1.13 MM m<sup>3</sup>/d) boiler flue gas facility will range from 75 to 82 cents/MCF (2.649 to 2.896 cents/m<sup>3</sup>). The costs for a 80 MMSCFD (2.265 MMm<sup>3</sup>/d) injection facility decrease to a range of 66 to 72 cents/MCFD (2.33 to 2.543 cents/m<sup>3</sup>).

The lack of scale economics in exhaust gas processes probably make all but the smallest operations uneconomical. The total injection costs of a 10 MMSCFD (.2832 MM m<sup>3</sup>/d) facility range from 61 to 66 cents/MCFD (2.154 to 2.33 cents/m<sup>3</sup>).

The injection cost ranges quoted above are very rough approximations. The cost of any one injection facility will vary as a function of a host of factors including location and reservoir characteristics. However, these approximations do provide a basis from which more detailed cost analyses could be generated.

In addition to injection costs, there are special recovery costs that can be reasonably expected in flue gas (boiler and exhaust) operations. Problems of corrosion and environmental control could add substantial costs to the operation. In addition, since nitrogen will be the dominant recovered inert gas, a cryogenic unit for nitrogen rejection will be required to maintain the heating value of the sales gas. This will add considerably to gas treating costs.

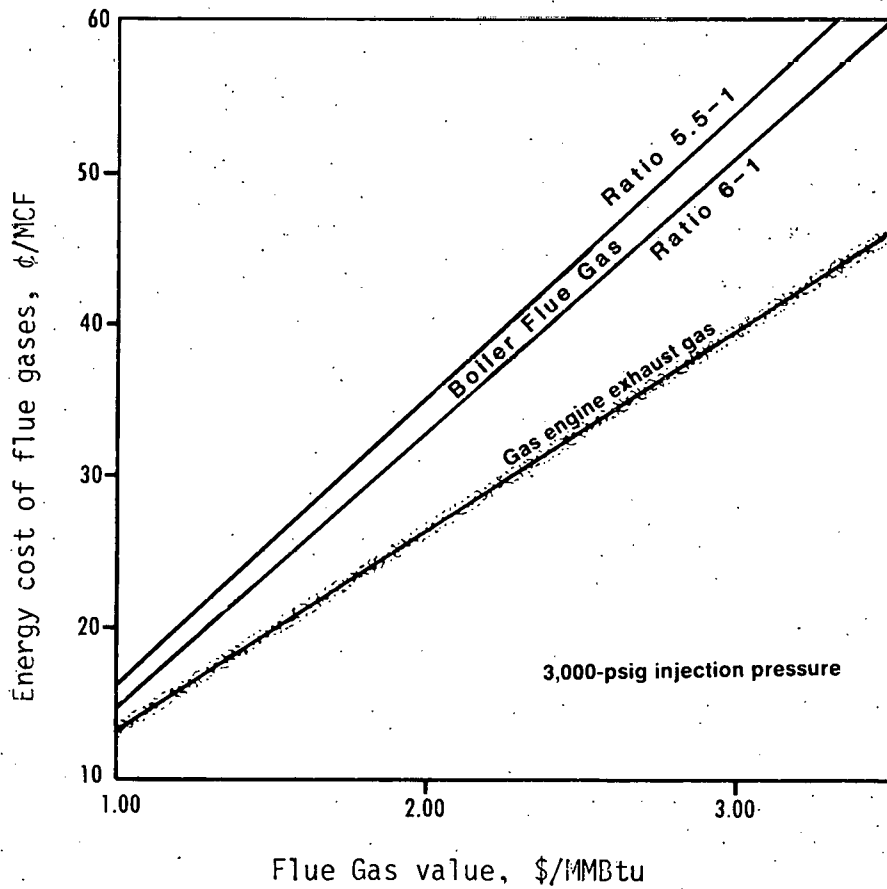

SI Metric Conversion Factors

psi x 6.894757 E - 03 = MPa

SCF x 2.831685 E - 02 = m<sup>3</sup>

Btu x 1.055056 E + 03 = J

Exhibit 5-8 Energy Cost - Flue Gas Generation Facilities as a Function of Natural Gas Price

Source: Ref. 5-2 and 5-9

The utilization of flue gas recovered from power plants and piped to the field has been suggested as a viable production alternative in EOR operations. Its viability, though, is greatly restricted because most large flue gas sources are electric generating facilities that are located near large cities, not crude oil producing areas. Studies (Ref. 5-7) have shown that pipelines of distances greater than 10 miles (16.0km) would probably be prohibitive in any flue gas injection EOR project. However, for those isolated cases where only small distances separate the field and the utility, the pipelining of flue gas from power plant to field may be economical.

A study by Lawrence-Allison and Associates (Ref. 5-7) conducted in 1979 for DOE analyzes the use of power plant flue gas to generate CO<sub>2</sub> for EOR operations. Some of the processes used and costs described are directly applicable to a determination of flue gas generation, compression, and utilization costs.

The composition of the power plant flue gas used in the analysis is:

	<u>Percentage</u>
Nitrogen	74.62
Oxygen	3.30
Carbon Dioxide	12.27
Water	9.80
Sulfur Dioxide	.01
	<u>100.00</u>

In order to utilize flue gas as a flooding mechanism in EOR operations, all water must be removed. Other conditioning is not necessary since sulfur compounds are not corrosive in the absence of water. Exhibit 5-9 shows the process used to compress, dry, and transport the flue gas.

The capital costs of compressing and drying the flue gas in preparation for pipeline transmission is estimated to be approximately \$8.5 million. The capital costs of building a 9 mile (14.5 km) long pipeline to deliver the flue gas is estimated at \$45/foot (\$137.16/m) or more than \$2 million total. It should be noted that the costs of pipeline construction are very sensitive to terrain and could be more than doubled. However, assuming the basic economic parameters outlined above and the amortization of pipeline equipment over a 10 year period, the total cost of flue gas injection from this process and pipeline structure is approximately 71 cents/MCF (2.5 cents/m<sup>3</sup>). This cost figure implies that for isolated cases where the operator and power plant are in close proximity, pipelining utility generated flue gas may be a viable economic alternative.



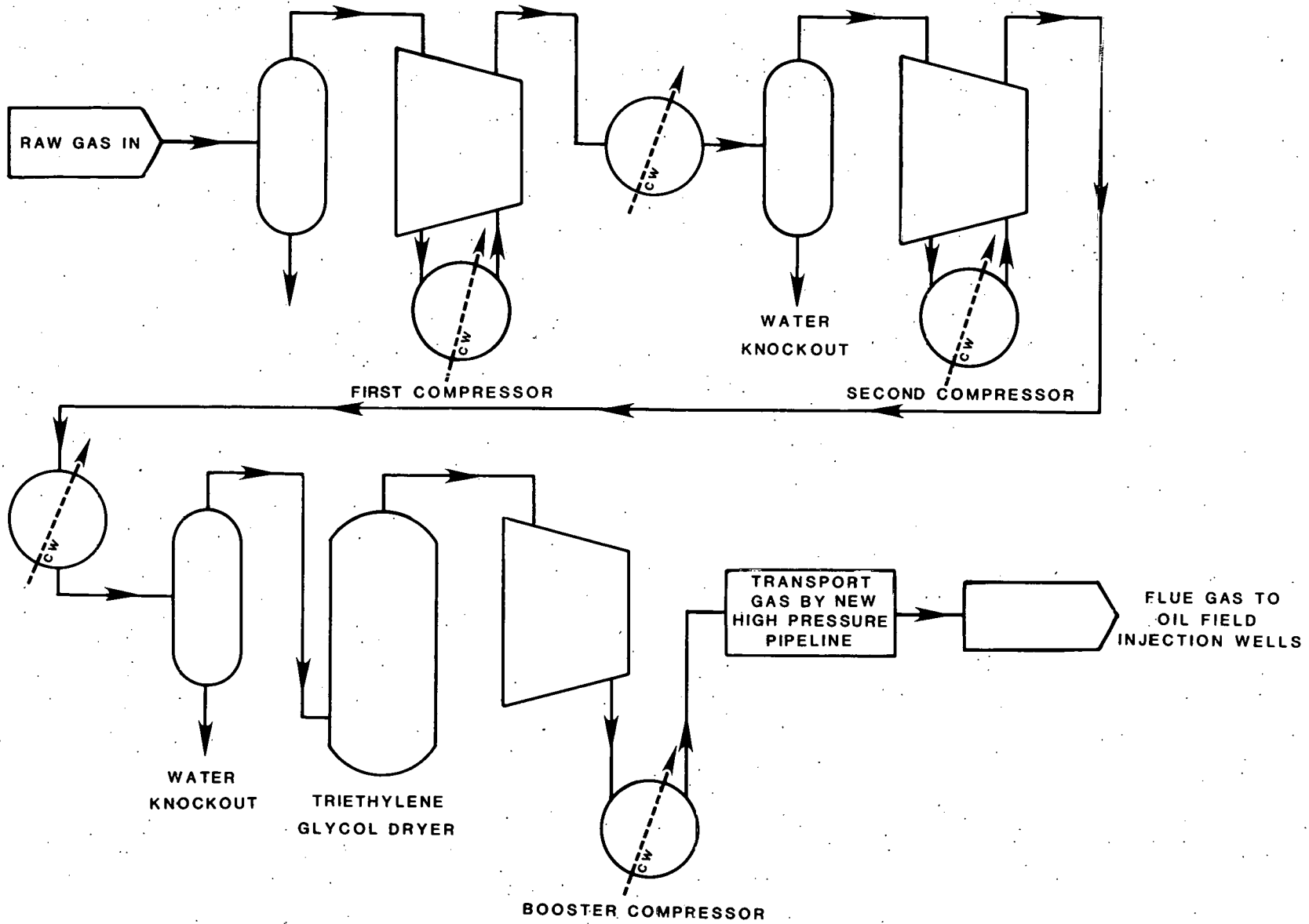

95

Exhibit 5-9 Schematic Diagram of Flue Gas Processing for EOR

Source: Ref. 5-7

### 5.3 COST COMPARISON OF N<sub>2</sub>/FLUE GAS INJECTION FOR EOR

Exhibits 5-10 and 5-11 display the ranges of fixed costs and energy costs operators of cryogenic, exhaust flue gas, and boiler flue gas injection projects can expect to incur. Exhibit 5-12 compares the total costs for these three processes assuming a per unit cost of energy (natural gas) of \$2.50/MMBtu (.237 cents/Mega Joule). Costs are adopted from Ref. 5-3 and Ref. 5-9 and are presented for different sized facilities. Costs are based on a 10 year project life and a delivery pressure of 3000 psig (30.7 MPa). The costs of pipelining flue gas recovered are not included.

The summation of fixed costs and energy costs roughly approximates the total costs of injection. In terms of fixed costs, only in the 20 to 70 MMSCFD (0.5 to 2 MM m<sup>3</sup>/d) range does there appear to be significant differences in the costs of the three processes. The cryogenic process seems likely to represent the lower range of fixed costs for all but the smallest plant size. In terms of energy costs, the cryogenic process usually represents the most competitive alternative. Within a framework where energy costs vary significantly by region and by type of fuel used, the flexibility of the cryogenic process in terms of its source and supply parameters greatly increases its economic viability. The total costs of any of the three processes are very competitive with CO<sub>2</sub> injection costs. It is probable that in many cases nitrogen or flue gas would be less costly than CO<sub>2</sub>.

### 5.4 CONCLUSIONS

- In view of the above considerations, it seems probable that nitrogen and flue gas injection costs compare very favorably with CO<sub>2</sub> injection costs - and in fact are cheaper by 30 to 60 percent. However, a detailed cost analysis should be conducted to determine the cost of nitrogen, flue gas, and CO<sub>2</sub> per bbl (m<sup>3</sup>) of additional oil recovered.
- Nitrogen is more readily available than CO<sub>2</sub>.
- Flue gases would only be economical in regions close to industrial plants, or at in situ combustion oil field operations.

It is recommended that a detailed cost analysis be performed in order to determine the relative costs of nitrogen and flue gases for specific cases. It is also recommended that an economic analysis of flue gas obtained from the byproducts of various fossil fuels and chemical industries be performed.

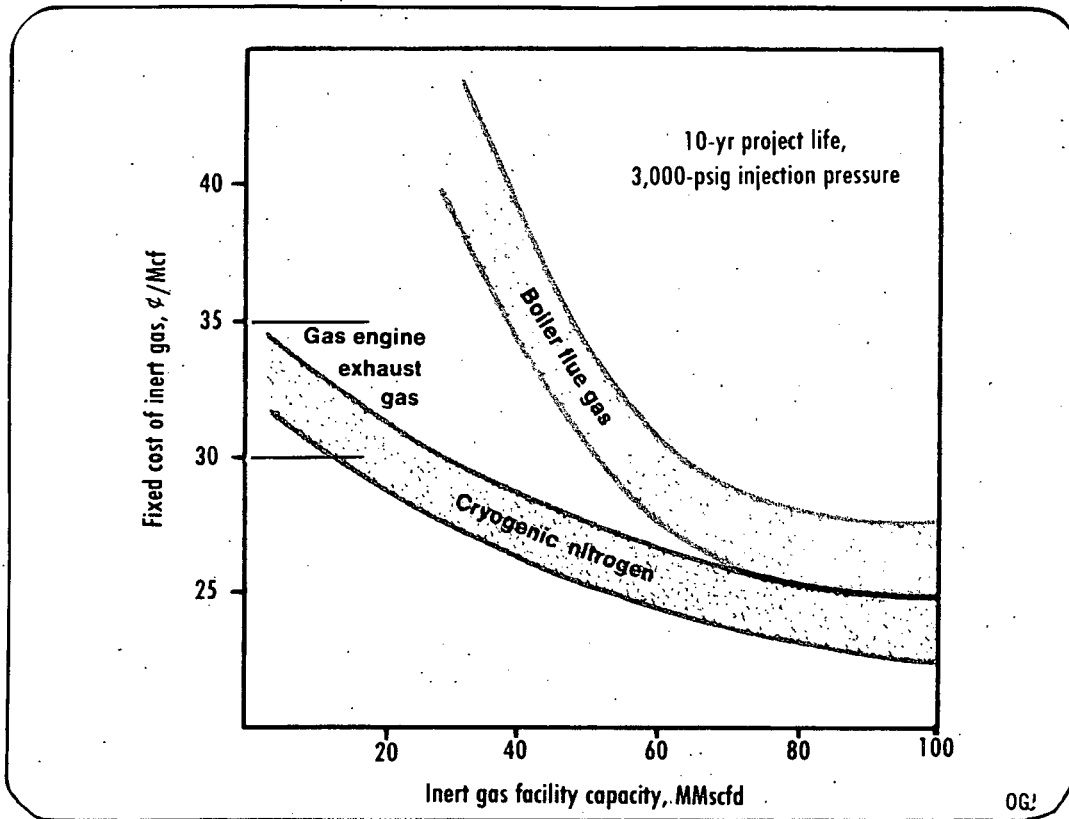

SI Metric Conversion Factors

psi x 6.894757 E - 03 = MPa

SCF x 2.831685 E - 02 = m<sup>3</sup>

Exhibit 5-10 Fixed Cost - N<sub>2</sub> and Flue Gas Production Facilities

Source: Ref. 5-2

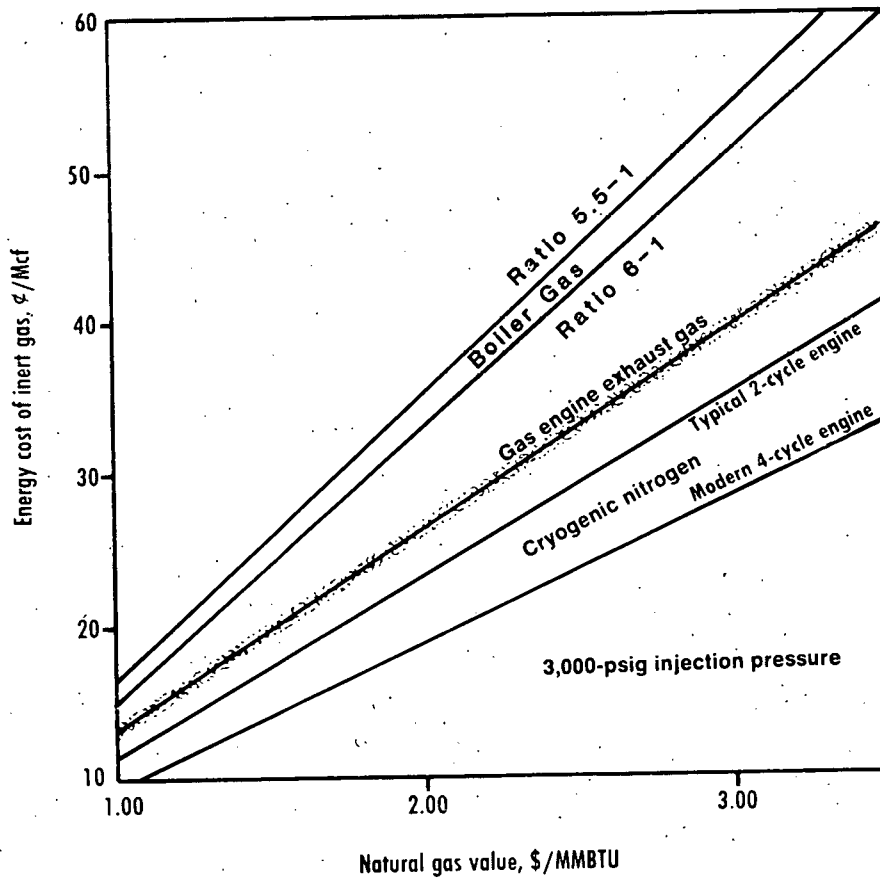

OGJ

SI Metric Conversion Factors

psi x 6.894757 E - 03 = MPa

SCF x 2.831685 E - 02 = m<sup>3</sup>

Btu x 1.055056 E + 03 = J

Exhibit 5-11 Energy Costs - Nitrogen and Flue Gas Production Facilities

Source: Ref. 5-2, 5-9

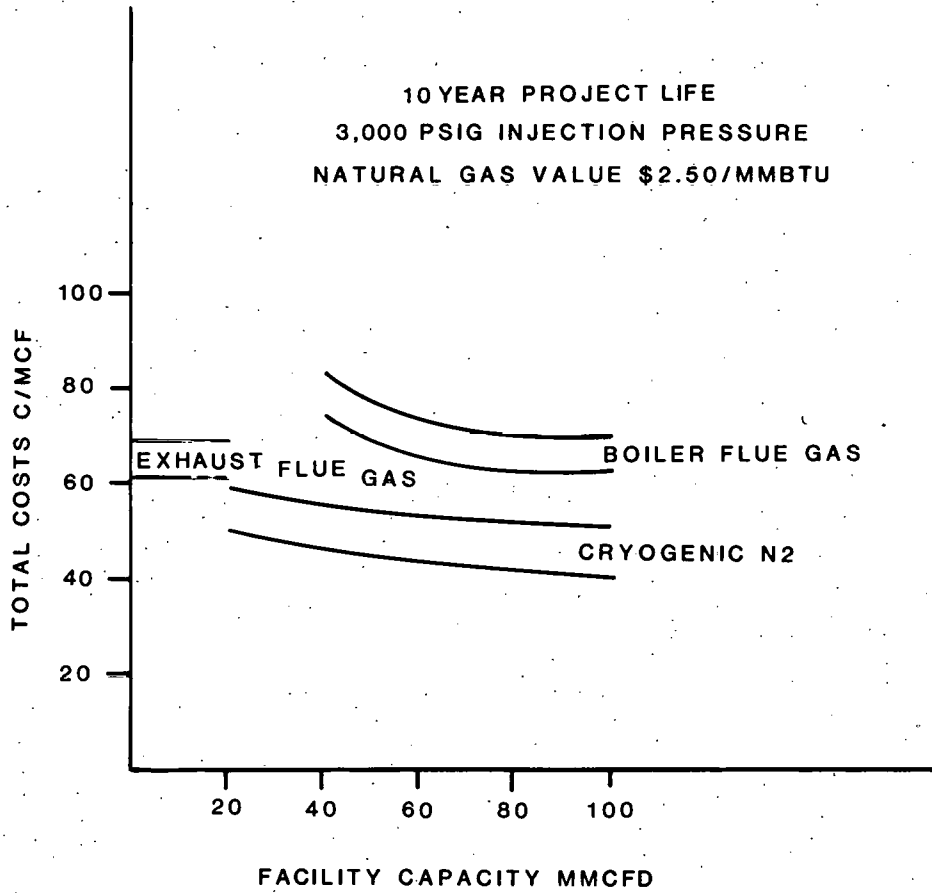

Exhibit 5-12 Approximate Total Costs of N<sub>2</sub> and Flue Gas

Source: Based on Data from Ref. 5-3 and 5-9

## References

- 5-1 Donohoe C. W., and R. D. Buchanan, "Economic Evaluation of Cycling Gas Condensate Reservoirs with Nitrogen," SPE 7494, October 1978.
- 5-2 Wilson, K., "Inert Gas Processes for Enhanced Recovery Compared," Oil and Gas Journal, July 31, 1978.
- 5-3 Anonymous, "Pure Nitrogen Can Make You Money," Air Products and Chemicals Inc., Publicity Brochure, 1977.
- 5-4 O'Leary, J. P., T. H. Murray, et al., "Nitrogen Drive CO<sub>2</sub> Slugs Reduce Costs," Petroleum Engineer International, May 1979, p. 130-140.
- 5-5 Calvin, J. W., and J. L. Vogel, "Evaluation of Nitrogen Injection as a Method of Increasing Gas Cap Reserves and Accelerating Depletion in the Ryckman Field, Uinta Co., Wyoming," SPE 8384, 54th Annual Fall Technical Conference and Exhibition, SPE/AIME, September 1979.
- 5-6 Kaye, S. E., V. C. Ting, and J. C. Fair, "Development of a System to Utilize Flue Gas from Enhanced Recovery Underground Combustion Project," SPE 8360, 54th Annual Fall Technical Conference and Exhibition, SPE/AIME, September 1979.
- 5-7 Anonymous, "A Study of CO<sub>2</sub> Recovery and Tertiary Oil Production Enhancement in the Los Angeles Basin," Lawrence-Allison and Associates Corporation, September 1978.
- 5-8 Heines, Ken, N. L. Industries New York, Y., Personal Communication, June 1980.
- 5-9 Wilson, Keith, Air Products and Chemicals, Inc., Allentown, PA, Personal Communication, July 1980.

## 6. DISCUSSION ON PROCESS AND RESERVOIR PARAMETERS

The process and reservoir parameters considered in this report are restricted to those directly involving gas injection processes. In general, these parameters are derived from the physical and chemical properties of the gas, the results of laboratory experiments, and field tests.

### 6.1 PROCESS PARAMETERS

The parameters of interest are dependent on the type of process to be used. Nitrogen and flue gas are applicable in the following processes:

- Gas Cycling
- Pressure Maintenance
- Attic Oil Recovery
- High Pressure Miscible Displacement
- Driving Gas for CO<sub>2</sub> Slugs
- Foam Fracturing
- Gas Lift

Process parameters and their significance with respect to EOR are discussed below:

<u>Process Parameters</u>	<u>Significance</u>	<u>References</u>
Viscosity of injection gas	Nitrogen has a viscosity factor the same order of magnitude as that of the gas-cap (natural gas) gas.	6.1
Formation volume factor of an injection gas. In general, a larger volume of natural gas will be displaced from a reservoir than the volume of N <sub>2</sub> or flue gas that is injected.	N <sub>2</sub> occupied 38 percent more pore space per unit volume than in-place gas, and the flue gas displaces 18 percent more pore space than in-place gas.	6.1,6.2, 6.3

Flue gas can cause corrosion and fouling problems, depending on the composition of the gas.

Flue gases must be dried to avoid corrosion; introduction of moisture at any point promotes corrosion of injection and production equipment.

6.4,6.5,  
6.6,6.7

A sulfur-removal plant for treatment of residual gas prior to combustion in the flue gas generator may be required to avoid this problem. A catalyst or a chemical compound such as  $\text{NH}_4\text{OH}$  may be used to neutralize carbonate and nitric acids. Ammonium carbonate plugging may be a problem over 600 psi (4.14 MPa) in coolers.

High flame temperature in engines to produce exhaust gas may produce nitrogen oxides, and finally nitric acids that could be corrosive.

Flame temperatures may be lowered by cycling the exhaust gas.

6.4

Flue gas flooding has provided positive results for 10 to 25 degrees API crudes having viscosities of over 100 centipoise (.01 Pa.s).

This may be attributed to the solution of  $\text{CO}_2$  components of flue gas in oil.

6.8,6.9

Flue Gas Components

Injection well plugging can occur due to compressor lubricants and  $\text{FeS}$  formed by the mixing of flue gas and sour crude in the injection well.

6.9

Under some conditions, flue gas injection may cause tight emulsion formation.

This could be due to reactions of gas components of flue gas with formation rock and/or petroleum constituents.

6.9

Nitrogen acts as a source of energy within injected fluids;  $\text{N}_2$  also pressurizes reservoirs.

An increase in reservoir pressure increases the production life of a reservoir.

6.10, 6-11,  
6.12, 6.13,  
6.14, 6.15



Nitrogen is miscible with oil at high pressures (generally over 4000 psi or 27.58 MPa). The miscibility pressure is highly dependent on the reservoir fluids.

In general, pressure requirements for miscibility of  $N_2$  are higher than for miscibility of  $CO_2$  in oil.

The ability of high-pressure gas drive processes to form a conditionally miscible zone is dependent on:

- crude's intermediate ( $C_2-C_6$ ) content
- process efficiency decreasing with decrease in pressure
- instabilities in transition zones
- reservoir fractures in various strata.

The flue gas miscible drive process works in a similar manner to that of  $CO_2$  miscible drive. This process will leave a heavy residual oil stripped of its light components. In a laboratory test using  $N_2$  as an injection gas in a 54.4° API oil that had a gas oil ratio (GOR) of 700 SCF/bbl ( $124.7 \text{ m}^3/\text{m}^3$ ), had an increase in recovered oil with an increase in injection pressure.

6.16

Nitrogen is an effective displacing gas for condensate reservoir cycling.

Nitrogen can be easily removed from the produced gas to increase its Btu content.

6.3, 6.17

Nitrogen has a favorable density-gravity factor.

Generally lighter than the gas-cap gas.

6.1, 6.15

Nitrogen is more soluble in light (higher API gravity) oils.

Greater than 35° API oil.

6.1, 6.18

Pressure and salinity are important in the solubility of  $N_2$  in water and brines.

$N_2$  is less soluble in water and brines than flue gas and carbon dioxide.

6.2

Other process parameters that are important to nitrogen or flue gas injection include:

- Blowdown effects and timing.
- Fuel or energy requirements for the production of injection gas.
- Additional absorbed capacity requirements.
- Nitrogen removal from produced gas and the capacity of cryogenic plant to remove nitrogen.

## 6.2 RESERVOIR PARAMETERS

Reservoir parameters also play an important role in the applicability of a specific process to a specific reservoir. Reservoir parameters and their significance with respect to specific gas injection processes are discussed below.

<u>Reservoir Parameters</u>	<u>Significance</u>	<u>References</u>
Temperature	Nitrogen compressibility is less temperature dependent than CO <sub>2</sub> or methane. Lower temperatures require higher gas injection.	6.2, 6.7, 6.16
Porosity	<p>If average net porosity is considered, nitrogen and flue gas flooding would be applicable in a reservoir that is suitable for CO<sub>2</sub> flooding.</p> <p>Heavily fractured reservoirs are not desirable. Reservoirs with consistent porosity (homogeneity) are desirable.</p>	
Permeability	The average horizontal permeability and the relative permeability behavior of a reservoir are important parameters in determining the applicability of a gas injection process. Reservoir heterogeneity is very important as it affects the conformance or vertical sweep efficiency of the flood. High permeability zones in a reservoir could result in high mobility, resulting in early break through and low sweep. In general, gas injection processes can be applied in lower permeability reservoirs ( $\sim 10$ md or $9.87 \times 10^{-3} \mu\text{m}^2$ ) than can chemical flooding ( $\sim 50$ md or $49.3 \times 10^{-3} \mu\text{m}^2$ ) and thermal recovery ( $\sim 300$ md or $296.1 \times 10^{-3} \mu\text{m}^2$ ) processes.	6.19
Connate Water	Salinity and the composition of connate water are important in gas injection processes. These are more important in flue gas injection processes, because the reaction of the flue gas and connate water components can react to form compounds that may plug a reservoir.	

Saturation Pressure	Saturation pressure is important in determining injection pressure, and whether the gas drive will be miscible or non-miscible.	6.16
Pressure	Nitrogen and methane viscosities are of the same order of magnitude, to 6000 psig (41.37 MPa).	
	The solubility of nitrogen in water and brine is pressure sensitive.	6.2, 6.6, 6.20, 6.15, 6.16, 6.17
	The N <sub>2</sub> dew point change is more pronounced than that for natural gas, given a similar pressure differential.	
	The miscibility pressure of an injected gas is highly dependent on the reservoir depth and pressure.	
	The slow loss of bottomhole pressure is advantageous as it will not require a large volume of injection gas for the rebuild-up of pressure due to process equipment failure. Thus, it will allow for down-time of process equipment without a big penalty.	
	If reservoir pressure drops below the bubble point of the injection gas, phase separation will occur.	
Crude Oil Composition and Properties	N <sub>2</sub> oil miscibility occurs if the crude contains sufficient intermediates (C <sub>2</sub> -C <sub>6</sub> ). The miscibility is believed to be due to the vapor extraction phenomena.	6.6, 6.16
Crude Viscosity and Gravity	Low viscosity and high API gravity oils are preferred for N <sub>2</sub> injection processes.	
	The viscosities and API gravities suitable for CO <sub>2</sub> miscible processes (less than 10 cp (.001 Pa.S) and greater than 35° API) are also suitable for nitrogen and flue gas flooding.	6.19

Stratification and Fracture Heterogeneity

For condensate reservoirs the unfavorable increase in dew point due to nitrogen injection is limited to those areas where nitrogen contacts oil. Mixing is influenced by:

- mobility ratios,
- molecular diffusion and intergranular dispersion,
- pore size distribution,
- changes in flow pattern, and
- change in reservoir pressure.

6.6, 6.20  
6.21

Depth

A shallow reservoir will not tolerate high pressures. The preferred reservoir depth for CO<sub>2</sub> flooding is greater than 2500 feet ( 760 m). Flue gas and nitrogen require a higher pressure for miscible displacement. This may require that the reservoir be deeper than 3000 feet ( 915 m).

6.21, 6.19

Oil Saturation

For reservoirs having less than 20 to 25 percent oil saturation the process may not be effective. Other reservoir parameters that are important for N<sub>2</sub> and flue gas include:

- Lithology of the reservoir,
- Thickness of the reservoir,
- Reservoir fluid properties (PVT relationship),
- Natural water drive, and
- Gas-cap.

In general, the most critical reservoir parameters for EOR gas recovery processes when considering the gas/reservoir interaction are pressure, temperature, permeability, porosity, and the effects on petroleum fluids of the gas utilized at various pressures.

Gas volumes required for injection will increase with lower temperatures and pressures. When flue gas is used, the volume of CO<sub>2</sub> absorbed by connate water is a factor. Nitrogen compressibility is less temperature dependent than that for CO<sub>2</sub>.

Both nitrogen and CO<sub>2</sub> can be used for miscible flooding, although nitrogen requires much higher pressures for miscibility. If a miscible drive is indicated, consideration should be given to the mixing of the nitrogen with reservoir fluids. Mixing and therefore, miscibility, will be enhanced by

those aspects of the reservoir that cause turbulence in the gas- or liquid-driven phase. If reservoir pressures drop below the bubble point of the gas being used, phase separation will occur. Miscibility pressure is also dependent on reservoir temperature. For an oil of a given composition, miscibility pressure increases as systems temperature increases.

Shallow reservoirs will not tolerate high injection pressures, so that a miscible drive using flue gas (13% CO<sub>2</sub>) is more advantageous than that using nitrogen. Flue gas flooding can be applicable in <25<sup>o</sup> API gravity oils.

Gas condensate reservoirs with liquid contents greater than 100 bbl/MMCF (560 m<sup>3</sup>/MMm<sup>3</sup>) should be considered for pressure maintenance by nitrogen injection. Solution gas drive reservoirs with greater than 35<sup>o</sup> API gravity oil should be considered for miscible displacement by N<sub>2</sub> flooding.

#### References

- 6-1 Calvin, James W., and John L. Vogel, "An Evaluation of Nitrogen Injection as a Method of Increasing Gas Cap Reserves and Accelerating Depletion - Ryckman Creek Field, Uinta County, Wyoming," SPE 8384, 54th Annual Fall Technical Conference and Exhibition, SPE/AIME, September 1979.
- 6-2 Anonymous, "Physical Properties of Nitrogen for Use in Petroleum Reservoirs", Air Products and Chemicals, Inc., p.17, A Company Brochure, September 1977.
- 6-3 Koch, H. A. Jr., and C. A. Hutchinson Jr., "Displacement of Reservoir Oil Using Flue Gas," TP 4704, Petroleum Transactions, AIME, V. 213, 1958, p. 7-10.
- 6-4 Caraway, George E. Jr., and Leo L. Lowrey, "Generating Flue Gas for Injection Releases Sales Gas," Oil and Gas Journal, V. 73, No. 30, July 28, 1975, p. 126-132.
- 6-5 Clark, Norman Jr., Thomas G. Roberts, et al., "Engine Exhaust Gas Boosts Heavy Oil Recovery," Petroleum Engineer, August 1964, p. 43-47.
- 6-6 Hardy, Jay H., and Nelson Robertson, "Miscible Displacement by High-Pressure Gas at Block 31," Petroleum Engineer, November 1975, p. 24-28.
- 6-7 Wilson, Keith, "Enhanced-Recovery Inert Gas Processes Compared," Oil and Gas Journal, V. 76, No. 31, July 31, 1978, p. 162-172.
- 6-8 Davison, K., "Inert Gas Generators Stimulate Viscous Oil Flow," Petroleum Equipment, March-April, 1966, p. 6-8.
- 6-9 \_\_\_\_\_, "Inert Gas Boosts Recovery from Heavy Oil Reservoirs," World Oil, March 1967, p. 98-105.

- 6-10 Ott, William K., and E. H. Gras, "Flow Back, Commingled N<sub>2</sub> Fluid Curves Aid Planning," Oil and Gas Journal, V. 77, No. 9, February 16, 1979, p. 103-106.
- 6-11 \_\_\_\_\_, "Effects on Stimulation Fluid Density and Volume," Oil and Gas Journal, V. 77 No. 10, March 5, 1979, p. 160-162.
- 6-12 \_\_\_\_\_, "Perforating, Jetting, Drill-Stem Testing with Nitrogen," Oil and Gas Journal, V. 77 No. 11, March 12, 1979, p. 72-75.
- 6-14 Donohoe, Charles W., and Robert D. Buchanan Jr., "Economic Evaluation of Cycling Gas-Condensate Reservoirs with Nitrogen," SPE 7494, 53rd Annual Fall Technical Conference and Exhibition, SPE/AIME, October 1-3, 1978.
- 6-15 Peterson, Arthur V., "Optimal Recovery Experiments with N<sub>2</sub> and CO<sub>2</sub>," Petroleum Engineer International, November 1978, p. 40-50.
- 6-16 Warner, Harold R. Jr., J. H. Hardy, et al., "University Block 31 Middle Devonian Reservoir Study, Part I History Match," SPE 7468, 53rd Annual Fall Technical Conference and Exhibition, SPE/AIME, October 1-3, 1978.
- 6-17 Anonymous, "Use Low Cost Nitrogen, Manufactured Onsite, as a Substitute Gas for Injection to Increase Recovery," A Company Brochure, Oil and Gas Cryogenics, Inc., Houston, Texas, 8 p.
- 6-18 Rushing, Michael D., Bruce C. Thomasson, et al., "High Pressure Air Injection," Petroleum Engineer, November 1977, p. 52-56.
- 6-19 Aniekan, Willie Iyoho, "Selecting Enhanced Oil Recovery Processes," World Oil, November 1978, p. 61-64.
- 6-20 Moses, Phillip L., and Keith Wilson, "Phase Equilibrium Considerations in Utilizing Nitrogen for Improved Recovery from Retrograde Condensate Reservoirs," SPE 7493, 53rd Annual Fall Technical Conference and Exhibition, SPE/AIME, October 1-3, 1978.
- 6-21 Rushing, M. D., B. C. Thomasson, B. Reynolds, and Dr. P. B. Crawford, "Miscible Displacement with Nitrogen," Petroleum Engineer, November 1977, p. 26-30.

## 7. COMPARISON AND CONCLUSIONS

### 7.1 COMPARISON

In comparing nitrogen and flue gas flooding with respect to CO<sub>2</sub> EOR, emphasis in this report has been given to:

- Comparison of source, supply, and cost;
- Comparison of physical and chemical properties; and
- Comparison of process performance using nitrogen, flue gas, or CO<sub>2</sub> based on laboratory and field data.

Nitrogen has been considered as pure gas (99.995 percent pure) obtained by methods such as cryogenic separation. Flue gas can be obtained from various sources and its composition varies from 10 to 15 percent CO<sub>2</sub>, 80 to 85 percent nitrogen, with the remainder being other gases or impurities (depending on the source).

The major distinction between the physical and chemical properties of nitrogen and CO<sub>2</sub> are discussed. The properties of a flue gas lie between these two, depending on its composition. The major differences between CO<sub>2</sub> and N<sub>2</sub> lie in their volumetric, miscibility, viscosity, and gravity factors. These are discussed below.

- Nitrogen has a compressibility factor that is three times that of CO<sub>2</sub> at average reservoir temperatures and pressures.
- Nitrogen is relatively insoluble in most fluids while CO<sub>2</sub> is soluble in reservoir fluids.
- CO<sub>2</sub> is somewhat miscible with oil (miscibility is dependent on oil composition and reservoir pressure) as is nitrogen. However, nitrogen requires a higher miscibility pressure than CO<sub>2</sub>, given a specific oil. First contact miscibility occurs with CO<sub>2</sub> in reservoir condensate fluids at pressures of >4000 psi (27.58 MPa); first contact miscibility between nitrogen and oil does not occur below 6000 psi (41.37 MPa).
- Lab studies have shown that heavy crudes will not be good candidates for miscible displacement with nitrogen. Crudes of 35° API and higher make better prospects for miscible displacement with high pressure nitrogen injection.
- N<sub>2</sub> is inert and non-toxic; CO<sub>2</sub> is not inert. CO<sub>2</sub> is corrosive in the presence of an aqueous phase. Flue gas is generally more corrosive than CO<sub>2</sub>. Flue gas plants suffer corrosion problems at start-up due to moist air.

- $N_2$  is generally less dense than the gas-cap gas;  $CO_2$  is more dense under injection conditions.
- $CO_2$  increases the oil volume through solubilization by 10 to 40 percent; nitrogen effects on oil volume are negligible (0 to 2 percent).
- $CO_2$  reduces oil viscosity much more than does  $N_2$ .  $CO_2$  is also reported to reduce the viscosity of heavy oils (less than 25° API).
- $N_2$  and flue gas are much more readily available than  $CO_2$ .  $N_2$  can be produced from air using cryogenic plants. Flue gas can be made available from various fossil fuel plants and chemical industries. Cryogenic nitrogen processes are environmentally nondestructive.
- $N_2$  is better for pressure maintenance and gas condensate drive reservoirs than  $CO_2$  or flue gas because it is less soluble and requires less injection gas. The latter two are soluble both in oil and connate water.
- More  $CO_2$  is required to pressurize a reservoir than that required by  $N_2$ . Flue gas falls in between these two.
- The cost of  $CO_2$  is reported to be \$1.00 to \$1.25/MCF (3.53 to 4.41 cents/ $m^3$ ). Flue gas costs are \$0.55 to \$0.85/MCF (1.94 to 3.0 cents/ $m^3$ ), and those of  $N_2$  are \$0.40 to \$0.60/MCF (1.41 to 2.12 cents/ $m^3$ ), depending on the pressure and total amount required.
- Cryogenic plants have 97 to 99 percent on-stream time; thus, they are more reliable. Operating costs are low compared to those for flue gas plants.
- Flue gas needs treatment before injection, the severity of the treatment being dependent on the source of the flue gas (i.e., exhaust gas from an engine, power plant using coal, or refineries).
- Relatively more energy is required to compress nitrogen than for  $CO_2$  or flue gas.
- A laboratory study showed that at relatively low pressures (1200 to 1800 psi or 8.27 to 12.41 MPa), nitrogen driven,  $CO_2$  slugs produced more oil than nitrogen alone. This laboratory study was conducted using 31.4° API crude which showed a 62 percent recovery using  $N_2$  at 1200 psi (8.27 MPa) and 1850 psi (12.75 MPa); 86 percent recovery using  $N_2 + CO_2$  at 1200 psi (8.27 MPa); and over 90 percent recovery using  $N_2 + CO_2$  at 1850 psi (12.75 MPa).



## 7.2 CONCLUSIONS

Nitrogen flooding appears to have several advantages over flue gas and  $\text{CO}_2$  flooding. The reduced cost and noncorrosive nature of nitrogen is in its favor, while the high miscibility pressure requirement is a disadvantage. However, this disadvantage may be overcome by using nitrogen in combination with small amounts of  $\text{CO}_2$  in a process where  $\text{CO}_2$  slugs are followed or pushed by nitrogen injection. To obtain high efficiency in a gas drive process, it is necessary for the injected gas be miscible with oil.  $\text{N}_2$  by itself requires higher pressure for miscibility than does  $\text{CO}_2$ . Because of this, the compression cost would be high. However, the low cost of nitrogen is advantageous, and may offset the cost of compression and the higher volume requirement in specific cases. In order to compare nitrogen, flue gas, and  $\text{CO}_2$  flooding as used in EOR, one must know the requirements of injection gas per barrel of oil recovered and the cost of the gas for the operations. The  $\text{CO}_2$  requirements are reported to range from 5 to 25 MCF/bbl; however, this is still a debatable issue. There has not been enough experience using  $\text{N}_2$  as a miscible flooding agent, and no realistic comparison can be made without such data.

Flue gas flooding falls between  $\text{N}_2$  and  $\text{CO}_2$  flooding as far as the effectiveness of the gas drive is concerned. The cost of flue gas is reported to be about one-half that of  $\text{CO}_2$ . However, flue gas may create more corrosion problems, depending on the amount of sulfur compounds present. This requires special construction material and/or linings of noncorrosive material in pipes and equipment. Cleaning the flue gas of sulfur compounds and moisture is an alternative. However, this could be costly. Probably the best approach would be to use the flue gas with its sulfur compounds but to remove the moisture. Sulfur compounds in the absence of moisture are noncorrosive, although special equipment still may be needed for handling sulfur compounds, specifically  $\text{SO}_2$ . The major disadvantage of flue gas is that the effectiveness of the drive due to its  $\text{CO}_2$  components (miscibility), is reduced because of the presence of large quantities of  $\text{N}_2$ .  $\text{N}_2$  needs to be removed from the product gases. This necessitates a cryogenic plant at the product recovery area which could be costly.

Thus, it seems that flue gas, although available at one-half the cost of  $\text{CO}_2$ , may not be attractive because of associated problems. However, flue gas may be a good alternative for shallow heavy oil reservoirs.

Again, the selection of a specific type of gas injection for a specific reservoir depends on several criteria, including the availability and cost of the gas, and its effectiveness. Nitrogen by itself requires higher pressure, and thus, may be applicable for deep (deeper than 3000 feet or  $\sim$  915 m) reservoirs. A  $\text{CO}_2$  slug followed by nitrogen seems to be a promising process based on laboratory results. Flue gas is cheaper than  $\text{CO}_2$ , but has more problems. More nitrogen and  $\text{CO}_2$  injection schemes for use in EOR processes are being proposed and funded every year. Nitrogen is still new, but its use is expected to rise because it is readily available and is cost competitive.

## APPENDIX A - BIBLIOGRAPHY ON N<sub>2</sub> FLOODING

This bibliography includes articles on physical/chemical properties of nitrogen, source/supply/cost data, and laboratory and field work related to nitrogen injection.

### A-1 Related to Physical/Chemical Properties of N<sub>2</sub>

Anonymous, "Physical Properties of Nitrogen for Use in Petroleum Reservoirs," Air Products and Chemicals, Inc., A Company Brochure, September 1977, p. 1-17.

Basu, R. S., and J. V. Sengers, "Viscosity of Nitrogen Near the Critical Point", Journal of Heat Transfer, V. 101, February 1979, p. 3-7.

Besserer, G. J., and Donald B. Robinson, "Equilibrium-Phase Properties of Nitrogen-Hydrogen Sulfide System," Journal of Chemical Engineering Data, V. 20, No. 2, 1975, p. 157.

Moses, P. L., and Keith Wilson, "Phase Equilibrium Considerations in Utilizing Nitrogen for Improved Recovery from Retrograde Condensate Reservoirs," SPE 7493, 53rd Annual Fall Technical Conference and Exhibition, SPE/AIME, Houston, Texas, October 1-3, 1978.

Robinson, Donald B., Gerald P. Hamaluk, Thamra R. Krishnan, and P. Raj Bishnoi, Journal of Chemical and Engineering Data, V. 20, No. 2, 1975, p. 153-157.

Yaws, Carl L., H. S. N. Setty, J. R. Hopper, and V. Luna, "Physical and Thermodynamic Properties, Part 8, Major Diatomic Gases - H<sub>2</sub>, N<sub>2</sub>, O<sub>2</sub>....," Chemical Engineering, V. 82, No. 2, January 20, 1975, p. 99-106.

### A-2 N<sub>2</sub> Source/Supply and Cost

Donohoe, C. W., and R. D. Buchanan, "Economic Evaluation of Cycling Gas-Condensate Reservoirs with Nitrogen," SPE 7494. 53rd Annual Fall Technical Conference and Exhibition, SPE/AIME, Houston, Texas, October 1-3, 1978.

Joplin, J. L., and J. F. Joplin, "Cryogenic Nitrogen Plants Ready for Offshore," Petroleum Engineer International, May 1978, p. 156-161.

Wuensche, R., Nitrogen Removal from Gas Offers Alternative to LNG, Oil & Gas Journal, September 11, 1978, p. 67-69.

### A-3 N<sub>2</sub> Flooding-Laboratory Work

Chen, Lillian, Lung-Yu Chou, "Binary-Gas Diffusion of Methane-Nitrogen Through Porous Solids," Doctoral Dissertation, Michigan University, February 1974.

Crawford, Paul B., "Pressure Maintenance Needed Here," Journal of Petroleum Technology, November 1967, p. 1449-1450.

Jacobson, Richard T., "The Thermodynamic Properties of Nitrogen from 65 to 2000 K with Pressures to 10,000 Atmospheres," Doctoral Dissertation, Washington State University, December 1972.

Latto, B., and M. W. Saunders, "Viscosity of Nitrogen Gas at Low Temperatures Up to High Pressures: A New Appraisal," Canadian Journal of Chemical Engineering, V. 50, December 1972, p. 765-770.

McShale, J. B. Jr., and Paul B. Crawford, "Stripper Wells, Output Rise; Abandonments Fall," Oil & Gas Journal, May 14, 1979, p. 89.

O'Leary, J. P., T. H. Murray, T. Guillory, G. Grieve, M. C. Reece, M. Nugent, and T. Perkins, "Nitrogen-Driven CO<sub>2</sub> Slugs Reduce Costs," Petroleum Engineer International, May 1979, p. 136-140.

Ott, W. K. and E. H. Gras, "Flow Back, Commingled N<sub>2</sub>, Fluid Curves and Planning," Oil & Gas Journal, February 26, 1979, p. 103-106.

\_\_\_\_\_, "Effects on Stimulation Fluid Density, and Volume," Oil & Gas Journal, March 5, 1979, p. 160-162.

\_\_\_\_\_, "Perforating, Jetting, Drill-Stem Testing with Nitrogen," Oil & Gas Journal, March 12, 1979, p. 73-75.

Peterson, A. V., "Optimal Recovery Experiments with N<sub>2</sub> and CO<sub>2</sub>," Petroleum Engineer, International, November 1978, p. 40-50.

Razo, S. H., "Water and Gas Cyclic Pulsing Method for Improved Oil Recovery," Journal of Petroleum Technology, December 1971, p. 1467-1474.

Rothrock, R. Jr., and P. B. Crawford, "Nitrogen Floods Need Specialized Surface Equipment," Petroleum Engineer, August 1977, p. 22-24.

Rushing, M. D., B. C. Thomasson, B. Reynolds, and P. B. Crawford, "Miscible Displacement with Nitrogen," Petroleum Engineer, November 1977, p. 26-30.

\_\_\_\_\_, "Nitrogen May be Used for Miscible Displacement in Oil Reservoirs," Journal of Petroleum Technology, December 1978, p. 1715-1716.

Vogel, John L., and Lyman Yarborough, "The Effects of Nitrogen on the Phase Behavior and Physical Properties of Reservoirs Floods," SPE #8815, First Joint SPE/DOE Symposium on Enhanced Oil Recovery, Tulsa, Oklahoma, April 20-23, 1980, p. 47-56.

Wagner, W., "A Method to Establish Equations of State Exactly Representing all Saturated State Variables Applied to Nitrogen," Cryogenics, June 1972, p. 214-221.

#### A-4 N<sub>2</sub> Injection - Field Work

Anonymous, "Pressure-maintenance Job Uses Nitrogen," Oil & Gas Journal, February 21, 1977, p. 36-37.

Calvin, J. W., and J. L. Vogel, "An Evaluation of Nitrogen Injection as a Method of Increasing Gas Cap Reserves and Accelerating Depletion-Ryckman Creek Field, Uinta County, Wyoming," SPE8384, 54th Annual Fall Technical Conference and Exhibition, SPE/AIME, Las Vegas, Nevada, September 23-26, 1979.

Greenwalt, Wayne A., Saul Vela, L. D. Christian, and J. A. Shirer, "A Field Test of Nitrogen WAG Injectivity," SPE #8816, First Joint SPE/DOE Symposium on Enhanced Oil Recovery, Tulsa, Oklahoma, April 20-23, 1980.

Griffith, J. D., N. Baiton, R. J. Steffensen, "Ante-Creek - A Miscible Flood Using Separator Gas and Water Injection," Journal of Petroleum Technology, October 1970, p. 1232-1238.

Harvey, R. J., and F. K. Krebill, "Elk Basin - the Cinderella Field," Petroleum Engineer, February 1954, p. A37-A38.

## APPENDIX B - BIBLIOGRAPHY ON FLUE GAS AND/OR INERT GAS FLOODING

This bibliography includes articles related to flue gas source/supply/cost data, and flue gas flooding laboratory and field work.

### B-1 Flue Gas Source/Supply/Cost Data

Bleakley, W. B., "Barge Brings Inert Gas Where Needed," Oil and Gas Journal, April 1, 1968, p. 168-170.

Caraway, George E., Jr., and Leo L. Lowry, "Generating Flue Gas for Injection Releases Sales Gas," Oil & Gas Journal, V. 73, No. 50, July 28, 1975, p. 126-132.

Kaye, S. E., and J. C. Fair, "Development of A System to Utilize Flue Gas from Enhanced Recovery Underground, Combustion Projects," SPE 8360.

### B-2 Flue Gas Flooding - Laboratory Work

Bowman, R. W., A. K. Dunlop, and J. P. Tralmer, "CO/CO<sub>2</sub> Cracking in Inert Gas - Miscible Flooding," Materials Performance, April 1977, p. 28-31.

Clark, Norman, J., Thomas G. Roberts, and J. Dorsey Lindner, "Engine Exhaust Gas Boosts Heavy Oil Recovery," Petroleum Engineer, August 1964, p. 43-47.

Davison, K., "Inert Gas Generators Stimulate Viscous Oil Flow," Petroleum Equipment, March-April 1966, p. 6-8.

\_\_\_\_\_, "Inert Gas Boosts Recovery From Heavy Oil Reservoirs," World Oil, March 1976, p. 98-105.

Herbeck, E. F., R. C. Heintz, and J. R. Hastings, "Fundamentals of Tertiary Oil Recovery," Petroleum Engineer, April 1976, p. 66-71.

Holm, L. W., "Residual Oil - Can We Recover It Economically," Petroleum Engineer, December 1973, p. 17-18.

Koch, H. A., and C. A. Hutchinson Jr., "Miscible Displacements of Reservoir Oil Using Flue Gas," Petroleum Transactions #4704, AIME, July 22, 1957, p. 7-10.

Rushing, M. D., B. C. Thomasson, B. Reynolds, and P. B. Crawford, "High Pressure Air Injection," Petroleum Engineer, November 1976, p. 52-56.

Snyder, Robert E., "World Oil Forecast-Review - Recent Technology Previews New Production Trends," World Oil, February 15, 1970.

Warner, H. R., C. D. Davidson, and J. H. Hardy, "University Block 31 Field Study: Part 2-Reservoir and Gas Plant Performance Predictions," Journal of Petroleum Technology, August 1979, p. 971-978.

Warner, H. R., J. H. Hardy, N. Robertson, and A. L. Barnes, University Block 31 Field Study: Part 1-Middle Devonian Reservoir History Match, Journal of Petroleum Technology, August 1979, p. 962-970.

### B-3 Flue Gas Flooding - Field Work

Anonymous, "EOR Field Reports, Update Report No. 75-25-2/77, West Heidelberg Field - Compressed Air Injection," Gulf Oil Co., Enhanced Oil Recovery Field Reports, V. 2 and 3, September 1977, p. 293-296.

Anonymous, "EOR Field Reports, Update Report No. 75-22-1/78, Slaughter Field - Slaughter Estate Unit 12 Acre Pilot," Amoco Production Co., Enhanced Oil Recovery Field Reports, V. 4, No. 1, June 1978, p. 93-100.

Anonymous, "EOR Field Report, Update Report No. 77-43-1/79, Willow Draw-Attic Air Injection," Oil Development Co, Texas and USDOE, Energy in Enhanced Oil Recovery Reports, V. 5, No. 1, June 1979, p. 141-142.

Anonymous, "First Miscible Flood Tops 100 Million bbl," Oil & Gas Journal, September 1967, p. 66.

Anonymous, "Flue Gas Injection Underway in West Texas Block 31 Field," Petroleum Equipment and Services, January and February 1967, p. 44-50.

Anonymous, "Oklahoma Field Gets Flue Gas Injection," Oil & Gas Journal, September 12, 1977, p. 54.

Anonymous, "Texaco Exploits Reservoir Attics," Oil & Gas Journal, June 14, 1971, p. 75.

Barstow, W. F., "Engine Exhausts Boosts Oil Recovery," Oil and Gas Journal, V. 71, No. 13, March 26, 1973, p. 78-80.

Bleakley, W. B., "Miscible Flood Hikes Block 31's Oil Output," Oil & Gas Journal, October 1969, p. 67-70.

Godbold, F. S., "Humble Recovers Attic Oil with Unique Inert Gas System," World Oil, May 1965, p. 151-154.

Hardy, Jay H., and Nelson Robertson, "Miscible Displacement by High-Pressure Gas at Block 31," Petroleum Engineer, November 1975, p. 24-28.

Harvey, R. J., and F. K. Krebill, "Elk Basin - The Cinderella Field," Petroleum Engineer, February 1954, p. A37-A38.

Stewart, F. M., D. L. Garthwaite, and F. K. Krebill, "Pressure Maintenance by Inert Gas Injection in the High Relief Elk Basin Field," TP 4008, Petroleum Transactions AIME, V. 204, 1955, p. 49-57.

Tittle, Robert M., and Kentall, T., "Success of Flue Gas Program at Neale Field," SPE 1907, 42nd Annual Meeting of SPE, Houston, Texas, October 1-4, 1967.

Wilson, K., "Enhanced Recovery Inert Gas Processes Compared," Oil & Gas Journal, July 31, 1978, p. 162-172.

## APPENDIX C BIBLIOGRAPHY ON PATENT LITERATURE

Patents that are directly or indirectly related to the utilization of nitrogen, flue gas and, other gases (excluding CO<sub>2</sub> and Hydrocarbon gases) in EOR are alphabetically listed below with a brief discussion of their relevance.

1. Allen, Joseph C., "Method for Recovering Viscous Petroleum," US Patent No. 4,099,568, July 11, 1978.

Use of steam in combination with nitrogen and/or flue gas in EOR - Describes a process that uses a non-condensable, non-oxidizing gas ahead of and/or in combination with steam in heavy oil recovery. Nitrogen and flue gases are among proposed gases.

2. Allen, Joseph, C., "Carrier Gas Vaporized Solvent Oil Recovery Method," US Patent No. 4,008,764, February 12, 1977. Also Canadian Patent No. 1,024,066, January 10, 1978.

Use of solvent in combination with nitrogen as a carrier gas in heavy oil recovery. The gaseous mixture injected in the formation consists of a solvent (pentane, hexane, heptane, octane, carbon disulfides, etc.) and nitrogen.

3. Allen, Joseph C., "Recovery of Oil by a Vertical Miscible Flood," Canadian Patent No. 1,060,785, August 21, 1979.

Discloses a miscible displacement process suitable for recovering oil from steeply dipping oil formations. The process consists of injection of a solvent (propane LPG or lean gas containing C<sub>2</sub>-C<sub>6</sub> components) sufficient to form a slug or blanket at the top of the oil column, or at the gas-oil transition zone. After the blanket has been established, the driving fluid is injected to displace the slug downward through the reservoir, thereby displacing the oil ahead of it. The driving fluids proposed include CO<sub>2</sub>, N<sub>2</sub>, flue gas, air, and mixtures thereof.

4. Allen, Joseph, C., "Recovery of Oil by a Vertical Miscible Flood," US Patent No. 3,845,821, November 5, 1974.

Describes a process in which light hydrocarbons are injected to form a miscible slug which is then pushed by driving fluid (see Canadian Patent No. 1,060,785 by same inventor). Nitrogen and flue gas proposed as driving fluids.

5. Allen, Joseph, C., and David A. Redford, "Combination Solvent - Noncondensable Gas Injection Method for Recovering Petroleum from Viscous Petroleum Formations including Tar Sand Deposits," US Patent No. 4,109,720, August 29, 1978. Also Canadian Patent No. 1,018,058, September 17, 1977.

Solvent in combination with nitrogen and/or flue gas flooding. Describes a process for heavy oil or tar sand reservoirs that utilize a solvent for solvent extraction along with non-condensable gas for the gas drive to recover bitumen. The proposed non-combustible gases include nitrogen and flue gas.



6. Braden, William B. Jr., and George H. Agnew, "Method of Oil Recovery Employing Enriched Gas Drive with Control of Evolved Gas," US Patent No. 4,086,961, May 2, 1978.

Utilization of nitrogen and flue gas as supplemental gas.  $N_2$  and flue gas are proposed as make-up gas to supplement reinjected gas in enriched gas drive for use in EOR.

7. Bringham, William E., and John N. Dew, "Tertiary Oil Recovery Method," US Patent No. 3,410,341, November 12, 1968.

Describes a miscible slug process and mainly describes the use of  $CO_2$  and hydrocarbon gas as miscible agents. However, in their claim No. 2, they suggest the use of flue gas and nitrogen as a miscible fluids in their process.

8. Burnett, David B., "Single Well Oil Recovery Method Using Carbon Dioxide," US Patent No. 3,841,406, October 4, 1974.

Flue gas or nitrogen are injected in the reservoir to increase formation pressure before carbon dioxide is injected for miscible displacement of oil.

9. Burnett, David B., Robert B. Alston and Frank H. Lim, "Secondary Recovery Using Carbon Dioxide and an Inert Gas," US Patent No. 3,811,501, May 21, 1974, Also Canadian Patent No. 980,244, December 23, 1975.

Discusses a process using a mixture of carbon dioxide and inert gas. Air, nitrogen, and flue gas are among gases proposed as the inert gas. The mixture of  $CO_2$  and inert gas forms a slug. The slug is then pushed by an inexpensive driving fluid such as air,  $N_2$ , flue gas, separator gas, or mixtures thereof.

10. Chew, Tu-Nam, "Alternate Gas and Water Flood Process for Recovering Oil," US Patent No. 3,525,395, August 25, 1970.

The patent describes a process for additional recovery of oil from watered out reservoirs injecting inert gas and water using the WAG (water alternate gas) mechanism.

11. Crump, James S., "Method of Increasing Recovery of Oil," US Patent No. 2,880,801, April 7, 1959.

Miscible displacement of oil described in this patent consists of injecting hydrocarbon gas to form a miscible slug which is followed by inert gas injection. Nitrogen and air are suggested as inert gases.

12. Dott, Water M. Jr., and Wayne E. Stevens, "Method for High Pressure Selective Absorption of Gases," US Patent No. 3,097,917, July 16, 1963.

Describes a gas separation process using the absorption/desorption technique to produce gases suitable for injection into a formation for use in EOR.

13. Gower, George, H., "Apparatus for Manufacturing High Pressure Inert Gas," US Patent No. 3,579,308, May 18, 1971. Also US Patent No. 3,725,012, April 3, 1973.

Related to apparatus for manufacturing high pressure inert gas by burning a hydrocarbon fuel in an internal combustion engine.

14. Graft, Robert A., "Generation of Inert Gas for Secondary Oil Recovery," Canadian Patent No. 829,227, December 9, 1969.

Describes a method and an apparatus to generate inert gas ( $\text{CO}_2$  and  $\text{N}_2$ ) for use in EOR.

15. Farrell, Howard H., and Robert R. Matthews, "In Situ Preparation of Surface Active Agents in Subterranean Formations," US Patent No. 3,392,782, July 16, 1968.

Discloses an invention that relates to producing in situ surface active agents. This patent also suggests the use of nitrogen as a driving fluid to push the preceding slugs of surface active agent through the formation. A process in which nitrogen can be used as a chase gas to push the surfactant slugs is suggested.

16. Glass, Eugene D., and Colonel J. Russel, Jr., "Heavy Oil Recovery," US Patent No. 3,373,804, March 19, 1968.

Discusses a gas drive process for the recovery of heavy oil. The gas proposed is a mixture of oil soluble and insoluble gases. The patent also indicates that flue gas available could serve as such a mixture because  $\text{CO}_2$  content of flue gas is oil soluble whereas  $\text{N}_2$  content of flue gas is insoluble in oil.

12. Hearn, Charles L., and Charles S. Homès, "Optimum Oil Recovery for Carbon Dioxide Injection," US Patent No. 3,620,304, November 16, 1971.

Suggests a miscible displacement process in which inert gas is introduced after a slug of carbon dioxide is formed; thus, driving the carbon dioxide slug through the reservoir.

18. Hirt, John H., "Method of and Apparatus for Producing Inert Gas," Canadian patent No. 869,925, May 4, 1971.

Relates to an apparatus and method for producing inert gases consisting essentially of  $\text{CO}_2$  and  $\text{N}_2$  by the controlled ignition and combustion of air and gaseous hydrocarbons.

19. Lewis, Warren K., "Petroleum Recovery with Inert Gases," US Patent No. 3,193,006, July 6, 1965.

Describes the injection of nitrogen as a gas-cap drive, concurrently with the injection of carbon dioxide into the oil zone as a miscible displacement drive.

20. Magnie, Robert L., "Enhanced Recoveries of Petroleum and Hydrogen from Underground Reservoirs," US Patent No. 4,183,405, January 15, 1980.

Producer gas flooding is proposed. Describes a process that would use producer gas generated from coal for enhanced oil recovery.

21. Mulder, Fritho R. Eric, "Formation Flooding by Sulfur Dioxide for Recovering Oil and Gas," US Patent No. 3,353,597, November 21, 1967.

Describes a process which uses sulfur dioxide for miscible displacement of oil. The use of nitrogen and/or flue gas to drive the slug of  $\text{SO}_2$  formed in the reservoirs as  $\text{SO}_2$  is also suggested.

22. New, Robert V., "Apparatus for Production Amplification by Stimulated Emission of Radiation," Canadian Patent No. 861,887, January 26, 1971.

Relates to novel equipment that provides radio frequency electrical energy and an admix of carbon dioxide and nitrogen (or gases of different energy levels) for interaction in a transducer to emit the heat of infra-red radiation in a formation that would reduce the viscosity of heavy oils. The patent describes the apparatus that produces exhaust gas ( $\text{CO} + \text{N}_2$  mixture) and the electrical energy (for viscosity reduction) for the recovery of heavy oils.

23. Parrish, David R., "Carbon Dioxide Slug Drive," US Patent No. 3,586,107, June 22, 1971.

Describes a process in which a  $\text{CO}_2$  slug is first injected, then flue gas or air is injected, followed by a water drive.

24. Sharp, Lorld G., "Method of Recovering Oil by In Situ Produced Carbon Dioxide," US Patent No. 3,174,543, March 12, 1965.

Proposes use of flue gas or air to drive a miscible gaseous slug generated by in situ combustion.

25. Speller, Frank N. Jr., "Processes for Secondarily Recovering Oil," US Patent No. 3,675,715, July 11, 1972.

Describes a process to produce flue gas by the in situ combustion method. The flue gas produced in situ is recovered and mixed with a wet casing head gas at the surface, and is then reinjected for EOR.

26. Speller, Frank N. Jr., "Processes for Secondarily Recovering Oil," US Patent No. 3,964,545, June 22, 1976.

Describes a process using air injection to pressurize the formation and maintain the mobility of oil by diluting the oil with  $\text{CO}_2$ .  $\text{CO}_2$  is produced in situ as a byproduct of air injection, either by auto-oxidation of carbonaceous material in the reservoir, or by ignition of oil in the reservoir in situ oxidation process.

27. Squires, Fredrick, "Apparatus for and Method of Recovering Oil and Gas," US Patent No. 1,249,232, December 4, 1917.

Describes an apparatus for generating exhaust gas (from internal combustion engines used in oil fields) suitable for injection into oil-bearing strata, and a process of enhanced oil recovery using such a gas.

28. Stone, Herbert Lesson, "Method of Increasing Oil Recovery," US Patent No. 2,996,373, August 1, 1961.

Describes a process in which light hydrocarbon components are injected using one injection well and inert gases are injected using another injection well. Nitrogen and air are proposed as inert gases.

29. Theobald, Alan, "Production of Liquid Oxygen and/or Liquid Nitrogen," US Patent No. 4,152,130, May 1, 1979.

Related to nitrogen generation; describes an improved process for the production of nitrogen that can be used for injecting a formation.

30. Vairogs, Jris, "Recovery of Oil by Low-Pressure Miscible Gas Injection," US Patent No. 3,623,552, November 30, 1972.

Describes a method for the miscible displacement of oil using carbon dioxide or a mixture of CO<sub>2</sub> and nitrogen gas. It suggests the use of an inert fluid to drive the miscible slug. Inert fluids such as nitrogen, flue gas and air are proposed.

31. Wagner, Robert J., "Method for Recovery of Petroleum Deposits," US Patent No. 3,653,438, April, 1972.

Describes a method that uses inert gas injection for improved oil recovery.

**UNITED STATES DEPARTMENT OF ENERGY**  
BARTLESVILLE ENERGY TECHNOLOGY CENTER  
P.O. BOX 1398  
BARTLESVILLE, OKLAHOMA 74003

OFFICIAL BUSINESS  
PENALTY FOR PRIVATE USE, \$300

POSTAGE AND FEES PAID

UNITED STATES  
DEPARTMENT OF ENERGY



Return this sheet to above address, if you  
do NOT wish to receive this material ,  
or if change of address is needed  (indi-  
cate change, including ZIP code).