

27
10-11-78
20
NTIS

CONF-780663--

SERI/TP-34-048

MASTER

MASTER

Proceedings of the Solar Thermal Concentrating Collector Technology Symposium June 14 & 15, 1978

**Edited by
B.P. Gupta & F. Kreith**

August 1978

**Department of Energy
Contract No. EG-77-C-01-4042**

**Solar Energy Research Institute
Golden, Colorado**

DISTRIBUTION OF THIS DOCUMENT IS UNLIMITED

DISCLAIMER

This report was prepared as an account of work sponsored by an agency of the United States Government. Neither the United States Government nor any agency Thereof, nor any of their employees, makes any warranty, express or implied, or assumes any legal liability or responsibility for the accuracy, completeness, or usefulness of any information, apparatus, product, or process disclosed, or represents that its use would not infringe privately owned rights. Reference herein to any specific commercial product, process, or service by trade name, trademark, manufacturer, or otherwise does not necessarily constitute or imply its endorsement, recommendation, or favoring by the United States Government or any agency thereof. The views and opinions of authors expressed herein do not necessarily state or reflect those of the United States Government or any agency thereof.

DISCLAIMER

Portions of this document may be illegible in electronic image products. Images are produced from the best available original document.

NOTICE

This report was prepared as an account of the meeting sponsored by the United States Government. Neither the United States nor the United States Department of Energy, nor any of their employees, nor any of their contractors, subcontractors, or their employees, makes any warranty, express or implied, or assumes any legal liability or responsibility for the accuracy, completeness or usefulness of any information, apparatus, product or process disclosed, or represents that its use would not infringe privately owned rights.

This report has been reproduced directly from the best available copy.

PROCEEDINGS OF THE
SOLAR THERMAL CONCENTRATING COLLECTOR
TECHNOLOGY SYMPOSIUM

held in
DENVER, COLORADO
June 14 and 15, 1978

Edited and Compiled by
B.P. GUPTA and F. KREITH

NOTICE

This report was prepared as an account of work sponsored by the United States Government. Neither the United States nor the United States Department of Energy, nor any of their employees, nor any of their contractors, subcontractors, or their employees, makes any warranty, express or implied, or assumes any legal liability or responsibility for the accuracy, completeness or usefulness of any information, apparatus, product or process disclosed, or represents that its use would not infringe privately owned rights.

SOLAR ENERGY RESEARCH INSTITUTE
1536 Cole Boulevard
Golden, Colorado 80401

A Division of Midwest Research Institute

for the
U.S. Department of Energy
Division of Solar Technology
Under Contract No. EG-77-C-01-4042

PREFACE

The purpose of this symposium was to review the current status of the concentrating collector technology, to disseminate the information gained from experience in operating solar systems, and to highlight the significant areas of technology development that must be vigorously pursued to foster early commercialization of concentrating solar collectors. The symposium was coordinated by the Solar Energy Research Institute, Golden, Colorado, on behalf of the Thermal Power Systems Program, Division of Solar Energy, within the Office of Assistant Secretary for Energy Technology, U.S. Department of Energy.

The first day of the two-day symposium was used to provide an overview of the technology. Six invited speakers presented the analytical considerations, the commercial designs in use, the thermal and photovoltaic applications of concentrating collectors, and the new developments in progress. A talk on the international developments and applications of concentrators provided the attendees with a bird's-eye view of all significant activity in countries other than the United States. Prepared text of the six invited papers is included in Section I.

As the symposium was intended to be a participating activity, the second day was devoted to two sessions of working groups. The morning session, Session 1, included five parallel working groups. The discussion topics and the discussion leaders were as follows:

Session 1

- Group 1: Reflective Surfaces, Surface Preparation, and Absorber Coatings Performance. Pat Call and Keith Masterson, SERI.
- Group 2: Mechanical and Structural Analysis and Design Consideration. Mel Frohardt, Martin Marietta.
- Group 3: Materials and Fluid Compatibility. Steven Pohlman, SERI.
- Group 4: Performance Standards Development for Concentrating Collectors. Byard Wood, Arizona State University.
- Group 5: System Controls. Jim Tobias, Honeywell, Inc.

The afternoon session, Session 2, included four parallel working groups. The discussion topics and the discussion leaders were as follows:

Session 2

- Group 1: Cleaning and Maintenance Processes and Cost of Time Phased Cleaning. Roscoe Champion, Sandia Laboratories.
- Group 2: High Temperature Receiver Materials Performance. L. Davis Clements, Texas Tech University.
- Group 3: Production and Manufacturing. Dave Feasby, SERI.
- Group 4: Line Focus Receiver Technology. Howard Gerwin, Sandia Laboratories.

At the end of each of the two sessions, the leaders presented a summary of the discussions.

The working groups were well attended, and participation and discussions were lively. Reports describing consensus results of these meetings were prepared by the group leaders and are included in Section II. These reports also provide the conclusions reached and the recommendations made by the participants.

A list of the 175 persons attending the symposium is included in these proceedings. Also, a list of participants in each working group is included at the end of the individual working group summaries.

We hope that this symposium volume will provide to the solar concentrating collector community a review that will help in the generation of new concepts, in production and manufacturing of collectors, and in the widespread application of concentrators with a view toward commercialization of this emerging technology which holds the greatest promise for satisfying a wide range of energy needs of electrical generation, total energy, industrial process heat, heating and cooling, irrigation, and photovoltaic systems.

Many people contributed to this symposium. In particular, the organizers of the symposium wish to express their sincere appreciation to the authors of the six invited papers for diligently preparing the written text and the presentations which provided the attendees with authoritative information of current

interest. Appreciation is also expressed to the leaders of the working groups for undertaking the task of preparing the discussion topics and the consensus summaries after the conference. It is due to the efforts of the speakers and the discussion leaders that the proceedings could be compiled in a timely manner. Of course, the attendees must be recognized for their patience and all-out participation, which made the symposium meaningful.

Special appreciation and recognition are due to the Conferences Group at the Solar Energy Research Institute for its exceptional work in preparing for the symposium as well as for its assistance during the two hectic days of the symposium.

TABLE OF CONTENTS

Section I. Invited Papers

	<u>Page</u>
Optical and Thermal Analysis of Concentrators, Ari Rabl, Solar Energy Research Institute	1
Linear Concentrating Solar Collectors--Current Technology and Applications, James A. Leonard, Sandia Laboratories	43
The Parabolic Concentrating Collector, Vincent C. Truscello, Jet Propulsion Laboratory	73
The Solar Thermal Test Facility Heliostat Development, D. E. Arvizu, Sandia Laboratories	121
Concentrators for Photovoltaics, Charles E. Backus and Byard D. Wood, Arizona State University	157
International Developments in Concentrators, J. D. Walton, Jr., Georgia Institute of Technology	225

Section II. Working Group Summaries

Session 1

Group 1	Absorber Surfaces and Reflective Materials, Pat Call and Keith Masterson, Solar Energy Research Institute	281
Group 2	Mechanical-Structural Analysis and Design Considerations, M. W. Frohardt, Martin Marietta	295
Group 3	Materials-Fluid Compatibility, Steven Pohlman, Solar Energy Research Institute.	303
Group 4	Performance Standards Development for Concentrating Collectors, Byard Wood, Arizona State University	311
Group 5	Controls for Concentrating Collector Systems, James Tobias, Honeywell, Inc.	329

TABLE OF CONTENTS (Continued)

<u>Session 2</u>		<u>Page</u>
Group 1	Cleaning and Maintenance, Roscoe L. Champion, Sandia Laboratories	339
Group 2	High Temperature Receiver Materials Performance, L. Davis Clements, Texas Tech University	349
Group 3	Collector Production and Manufacturing, Dave Feasby, Solar Energy Research Institute	359
Group 4	Line Focus Receiver Technology, Howard Gerwin, Sandia Laboratories	371
	List of Attendees	379

SECTION I

INVITED PAPERS

OPTICAL AND THERMAL ANALYSIS OF CONCENTRATORS

by

ARI RABL

SOLAR ENERGY RESEARCH INSTITUTE

Golden, Colorado

SUMMARY

In Section I the general relation between concentration ratio and acceptance angle is discussed and illustrated with examples for typical designs of solar concentrators. To a good approximation a collector of concentration C accepts $1/C$ of the diffuse solar radiation.

Section II addresses special optical properties of linear concentrators. Whereas the focal length of linear reflectors is constant, the focal length of linear refractors (Fresnel lenses) decreases with angle of incidence (along the concentrator axis); therefore, collectors with Fresnel lens are practical only with north-south tracking axis. A simple method is presented for analyzing the optics of glass tubes.

Section III provides a general framework for analyzing the efficiency of thermal collectors. The instantaneous efficiency can be referred to different bases for insolation measurement (e.g., pyranometer or pyrliometer) or for temperature measurement (e.g., receiver surface temperature or fluid temperature). Conversion factors are given for converting the efficiency from one base to another. The relationship between instantaneous efficiency and long-term average energy delivery is discussed, and use of the long-term average optical efficiency $\bar{\eta}_0$ is recommended as a simple means of incorporating incidence angle effects.

Section IV describes a particular class of concentrators, the CPC (= compound parabolic concentrator), and presents performance data for solar collectors with CPC reflectors and evacuated receiver tubes. The optical efficiency of these collectors is about 0.55 with off-the-shelf components and has been raised above 0.70 by means of silvered reflectors and low-cost antireflection coatings. The \bar{U} -value is on the order of $2/C \text{ W/m}^2 \text{ }^\circ\text{K}$, where C is the concentration ratio. Operating efficiencies above 40% at 150°C have been demonstrated with fixed CPC collectors (concentration $C = 1.5$) and off-the-shelf components (receiver tubes supplied by General Electric and by Owens-Illinois).

I. INTRODUCTION

A. DEFINITION OF CONCENTRATION

Concentration of solar radiation becomes necessary when working fluid temperature above that typically achievable with a flat-plate collector is desired.

Two definitions of concentration are natural and have been in use; to avoid confusion a subscript should be added whenever the context does not clearly specify which definition is meant. The first definition is strictly geometrical as ratio of aperture area* and receiver surface area, and the names

$$C = C_{\text{area}} = \frac{A_a}{A_r} \quad (\text{I-1})$$

geometric concentration, or area concentration for short, are recommended. The second definition, in terms of intensity ratio at aperture and at receiver,

$$C_{\text{flux}} = \frac{I_r}{I_a} \quad (\text{I-2})$$

involves absorption effects in addition to geometry and should be referred to as flux concentration. While flux concentration is a useful concept in photovoltaic work, the geometrical definition is more appropriate for solar thermal collectors because heat losses are to a good approximation proportional to the receiver area, and acceptance of diffuse radiation is inversely proportional to area concentration. Therefore, throughout this paper, "concentration" shall mean "area concentration" even if not explicitly stated.**

* Real aperture area, i.e., without cosine factor.

**On occasion, somewhat arbitrary definitions of concentration have been used, for example, the ratio of aperture width over receiver tube diameter. If concentration is to be a general and useful concept, the conventions of Eq. (I-1) or Eq. (I-2) should be followed consistently.

Closely related to the concentration is the acceptance angle, i.e., the angular range over which all or almost all (say 95%) of the incident rays are accepted without moving all or part of the collector.* The acceptance angle is one of the most important characteristics of a solar concentrator because it determines the tracking requirement. By considering phase space conservation [1] or reciprocity relations for radiation shape factors [2], one can show that the second law of thermodynamics imposes an upper limit on the concentration ratio achievable by any optical system with nonzero acceptance angle; this is sometimes called the thermodynamic (or ideal) limit of concentration. There must be a connection between optics and the second law of thermodynamics because if solar (or any other) radiation could be concentrated onto an arbitrarily small receiver, the receiver temperature could exceed the surface temperature of the sun (source of radiation). This would obviously be a violation of the second law which states that heat cannot flow unaided from a cold surface to a hot surface. The maximum possible concentration [1] for a given acceptance half angle θ_c for two-dimensional (trough-like, line focus) concentrators is

$$C_{\text{ideal, 2D}} = 1/\sin \theta_c \quad (\text{I-3})$$

and for three-dimensional ones (cones, dishes, pyramids, point focus) is

$$C_{\text{ideal, 3D}} = 1/\sin^2 \theta_c \quad (\text{I-4})$$

Since the angular radius of the sun is $\Delta_s \approx 1/4^\circ$, this limit implies a maximum of 200 for the concentration of a single axis tracking solar concentrator whereas for a point focus collector geometry, it is 40,000. However, the concentration achievable in practical systems is reduced by a number of factors [2]:

- (i) Most conventional concentrators, in particular line or point focusing types, are based on optical designs which fall short of the thermodynamic limit by a factor of 2 to 4.
- (ii) Tracking errors, errors in mirror surface and contour, and receiver alignment necessitate design acceptance angles

*The collector is assumed to consist of a receiver and a concentrator (lens or mirror).

considerably larger than the angular diameter of the sun.

(iii) No lens or mirror material is perfectly specular; therefore, the acceptance angle must be enlarged further. This effect is aggravated by dirt and dust.

(iv) Due to atmospheric scattering, a significant portion of the solar radiation may come from directions other than the solar disc itself.

The choice of optimal concentration for a given application involves consideration of these and many other factors (optical, climatic, thermal, economic, etc.), and it is unlikely that any single concentrator type will be desirable for all applications. To allow for meaningful evaluation and comparison of different collector types, it is imperative that a standardized format be adopted for testing and reporting of all collectors. Much of this paper is therefore addressed to the connection between measurement of collector efficiency and long-term performance prediction.

B. CONCENTRATION RATIO ACHIEVABLE IN PRACTICAL SYSTEMS

The choice of concentration ratio in a solar concentrator involves a compromise between optical and thermal performance. The absorber should be chosen as small as possible to reduce heat loss, yet large enough to intercept all, or almost all incident radiation. One therefore has to consider the rays with the largest expected deviation from the design direction i.e., the direction from collector aperture to center of sun. This angular deviation θ_c is due to the finite size of the sun and to mirror and tracking errors. The example of the parabolic trough reflector with cylindrical absorber tube, Fig. 1, serves to illustrate this procedure for focusing collectors; similar considerations apply for other absorber shapes. The absorber tube is placed concentrically around the focal line. If the ray with the largest deviation is to reach the absorber just barely, as shown by the dashed line in Fig. 1, then the concentration must be

$$C_{2D, \text{ parab., cyl. abs.}} = \frac{2X_A}{2\pi a} = \frac{\sin \phi}{\pi \sin \theta_c} = \frac{\sin \phi}{\pi} C_{\text{ideal}} \quad (\text{I-5})$$

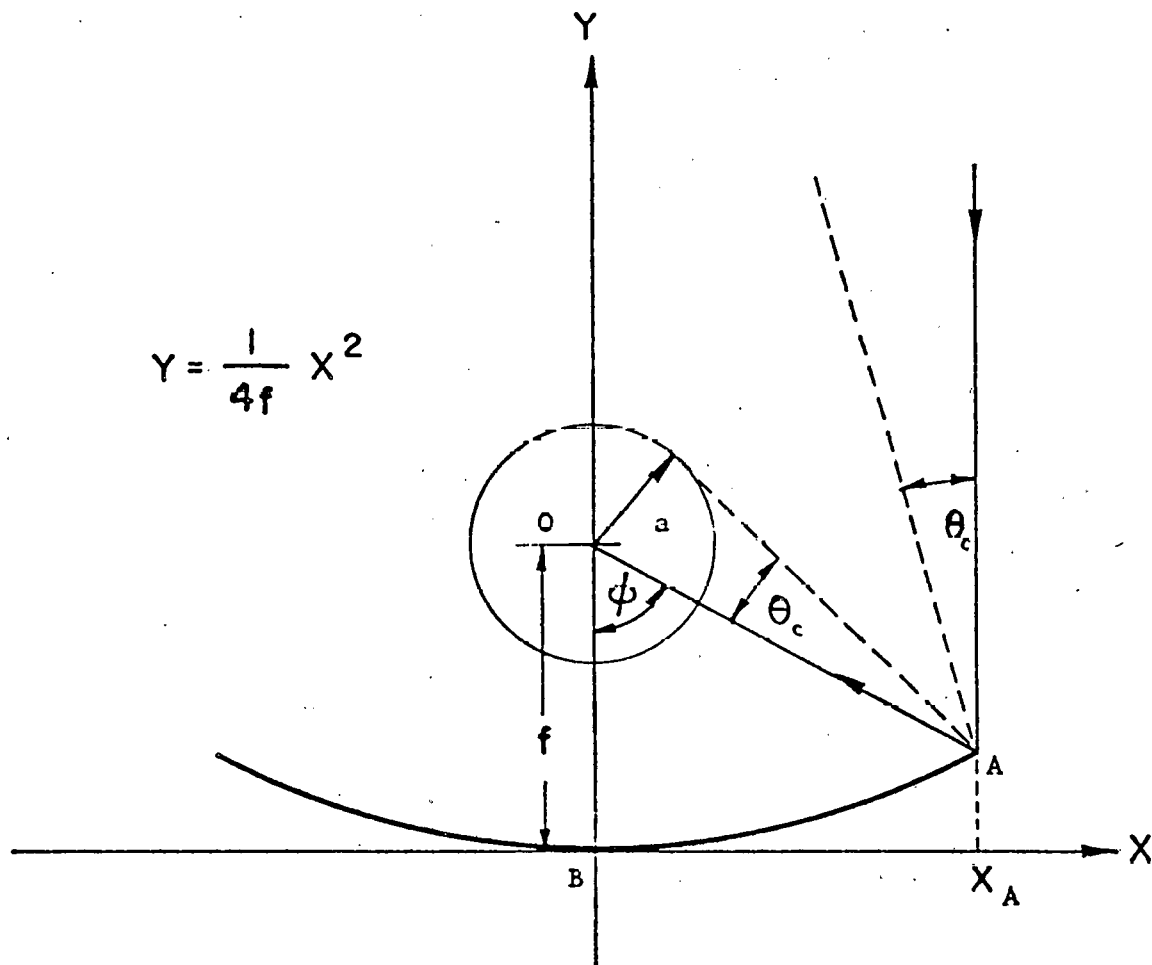

Fig. 1. Focusing parabola

where ϕ is the rim angle $\angle AOB$. The maximum occurs at $\phi = 90^\circ$ and falls a factor π short of the ideal limit. This is typical of all single stage focusing concentrators (i.e., they reach only one-fourth to one-half of the thermodynamic concentration limit). Table 1 lists the appropriate formulas for the most important geometries. The concentration is also expressed in terms of C/C_{ideal} for $C_{\text{ideal}} = 1/\sin \theta_c$ or $1/\sin^2 \theta_c$ for one- or two-axis tracking collectors respectively, and numerical values are given for several values of θ_c . For practical installations, geometric concentration is not the only design criterion, and slightly different rim angles can be substituted. For example, rim angles beyond 90° and undersized absorbers can be used if the incremental reflector cost is low.

TABLE 1

CONCENTRATION C AND MIRROR SURFACE/APERTURE AREA RATIO A_M/A_A AS FUNCTION OF RIM ANGLE ϕ AND ACCEPTANCE HALF ANGLE θ_c FOR PARABOLIC REFLECTOR. FLAT ABSORBER IS ONE-SIDED; CONCENTRATION FOR 2-SIDED FLAT ABSORBER CAN BE OBTAINED FROM $C_{2\text{-SIDED}} = 1/2 (C_{1\text{-SIDED}} + 1)$

type absorber shape	C	C for $\theta_c =$			C/C _{ideal}	A_M/A_A
		1/4°	1/2°	1°		
<u>2D (trough)</u>						
tube	$\frac{\sin \phi}{\pi \sin \theta_c}$				$\frac{\sin \phi}{\pi}$	$\left\{ \frac{1}{\cos(\phi/2)} + \left(\cos \frac{\phi}{2} \right) \right.$ $\left. \times \log \cot \left(\frac{\pi}{4} - \frac{\phi}{4} \right) \right\} / 2$
flat	$\frac{\sin \phi \cos(\phi + \theta_c)}{\sin \theta_c} - 1$				$\sin \phi \cos(\phi + \theta_c) - \sin \theta_c$	
<u>with optimal ϕ</u>						
round tube $\phi_{opt} = \frac{\pi}{2}$	$\frac{1}{\pi \sin \theta_c}$	73	37	18	$\frac{1}{\pi}$	1.15
flat $\phi_{opt} = \frac{1}{2} \left(\frac{\pi}{2} - \theta_c \right)$	$\frac{1}{2 \sin \theta_c} - \frac{3}{2}$	113	56	27	$\frac{1}{2} - \frac{3}{2} \sin \theta_c$	1.03
<u>3D (dish)</u>						
sphere	$\frac{\sin^2 \phi}{4 \sin^2 \theta_c}$				$\frac{\sin^2 \phi}{4}$	$\left\{ \frac{2[1/\cos(\phi/2) - \cos^2(\phi/2)]}{3 \sin^2(\phi/2)} \right.$
flat	$\frac{\sin^2 \phi \cos^2(\phi + \theta_c)}{\sin^2 \theta_c} - 1$				$\sin^2 \phi \cos^2(\phi + \theta_c) - \sin^2 \theta_c$	
<u>with optimal ϕ</u>						
sphere $\phi_{opt} = \frac{\pi}{2}$	$\frac{1}{4 \sin^2 \theta_c}$	13000	3300	820	$\frac{1}{4}$	1.22
flat $\phi_{opt} = \frac{1}{2} \left(\frac{\pi}{2} - \theta_c \right)$	$\frac{1}{4 \sin^2 \theta_c} - \frac{1}{2 \sin \theta_c} - \frac{3}{4}$	13000	3200	790	$\frac{1}{4} - \frac{1}{2} \sin \theta_c - \frac{3}{4} \sin^2 \theta_c$	1.04

There is, however, a class of nonimaging concentrators, the Compound Parabolic Concentrator or CPC, which actually reaches the thermodynamic limit, Eq. (I-3). This is important in practice because it permits the design of concentrating collectors with wide acceptance angle, in particular fixed collectors with concentration ratio up to 2 and nontracking but tilt adjustable collectors with concentration ratio up to about 10. Furthermore, a conventional focusing system with a matching CPC as second stage concentrator can closely approach the thermodynamic limit. An example of such a system is the Fixed Mirror Moving Receiver system built by General Atomic [3].

C. ACCEPTANCE FOR DIFFUSE RADIATION

Solar concentrators which are to require little or no tracking must have a fairly large acceptance angle, and therefore can collect a significant amount of diffuse radiation. A precise calculation of this effect would require detailed information about the angular distribution of diffuse sky radiation. Since, at the present time very little data on this distribution are available, we shall simply assume that the hemispherical insolation I_h is the sum of the direct component I_b (beam) and an isotropic background I_d (diffuse)

$$I_h = I_b + I_d \tag{I-6}$$

The fraction of the isotropic component I_d which is accepted by most solar collectors of concentration C, in particular V-troughs and CPCs is

$$1/C ,$$

independent of the details of the concentrator. (For some focusing parabolas with rim angle $\phi < 90^\circ$ and for Fresnel lenses without side reflectors, the acceptance for diffuse radiation may be as much as a factor 2 smaller than $1/C$. However, such concentrators would be used only in tracking systems with such high values of C that the contribution of diffuse radiation is negligible anyway.)

Due to the predominance of near forward scattering [4] in the atmosphere, the sky radiation tends to be centered around the sun, and therefore, the isotropic model underestimates the actual acceptance for diffuse radiation. Let us designate by γ the fraction of the hemispherical radiation I_h which falls within the acceptance angle of a solar concentrator. In terms of γ the above discussion can be summarized by the lower bound

$$\gamma \geq \frac{I_b}{I_h} + \frac{1}{C} \left(1 - \frac{I_b}{I_h}\right). \quad (I-7)$$

Data taken at Argonne National Laboratory suggest that γ is about 1% larger than this lower bound. Preliminary values [5] of γ for different acceptance angles and weather conditions are listed in Table 2.

The beam component I_b has traditionally been measured with a pyrheliometer, an instrument with a 2.8° acceptance half angle. This angle is much larger than the 0.25° half angle of the solar disk. The difference between the radiation from the solar disk and the total radiation incident within the cone angle of a pyrheliometer is defined as circumsolar radiation. Solar collectors with high concentration have small acceptance half angles, typically between 0.5 to 1° , and will, therefore, miss much of the circumsolar radiation. The severity of this effect depends strongly on sky conditions. Collectors designed with small acceptance angles do not utilize circumsolar radiation. If the receivers were redesigned to use the circumsolar radiation, the collector output may increase by a small amount (about 1%) in very clear climates (e.g., Albuquerque, New Mexico) and as much as 5% in more hazy climates (e.g., Fort Hood, Texas) [4].

TABLE 2

ESTIMATES OF ENERGY COLLECTION FOR DIFFERENT COLLECTOR DESIGNS*

Conditions	Hemispherical Insolation (a) (w/m^2)	Energy Available to Collector as % of Hemispherical Insolation				
		Beam ^(b)	Estimates for ^(c) Focusing Collector	CPC Collector ^(d)		
				(C=10)	(C=5)	(C=3)
Light haze- blue sky	≈ 1000	88	87	89	91	92
Heavy haze- white sky	≈ 920	79	60	82	85	87

(a) pyranometer at normal incidence.

(b) normal incidence pyrhelimeter, 2.3° acceptance half angle.

(c) estimate based on circumsolar data of Lawrence Berkeley Laboratory [4], assuming that focusing collector sees only solar disk.

(d) The values of C heading each column refer to Concentration Factor.

* courtesy of Dr. K. A. Reed of Argonne National Laboratory

II. OPTICAL PROPERTIES OF LINEAR CONCENTRATORS

A. OPTICS OF LINEAR REFLECTORS

The optical analysis of linear or troughlike reflectors is relatively simple because a two-dimensional analysis is sufficient, even at nonnormal incidence. This follows from the law of specular reflection. Suppose the trough is placed, as in Fig. 1, parallel to the z-axis; and suppose a ray entering in the direction $i = (i_x, i_y, 0)$ has been found to reach the receiver with direction vector $s = (s_x, s_y, 0)$. Then a ray entering in the direction

$$\hat{i}' = (i_x \sqrt{1 - (i'_z)^2}, i_y \sqrt{1 - (i'_z)^2}, i'_z), \quad (\text{II-1})$$

with arbitrary i'_z has the same (x,y) projection and leaves with

$$\hat{s}' = (s_x \sqrt{1 - (i'_z)^2}, s_y \sqrt{1 - (i'_z)^2}, i'_z), \quad (\text{II-2})$$

no matter how many reflections have occurred. This implies that, in troughlike reflectors, the ray trace diagram and, in particular, the focal length, is independent of the elevation of the incident ray from the xy plane. This contrasts with linear refractive concentrators whose focal length changes with nonnormal incidence as discussed in the following subsection.

There are, however, two characteristics of troughlike reflectors for which the elevation of the sun from the projection plane do make a difference. Firstly, there is the end effect of finite troughs which can be compensated by the addition of flat end reflectors. It can also be minimized by building long troughs or by using polar mount. Secondly, there is an increase in the projected (on xy plane) angular width[6] of the sun which necessitates a larger absorber. Figure 2c illustrates this feature by showing schematically the position of the sun relative to the

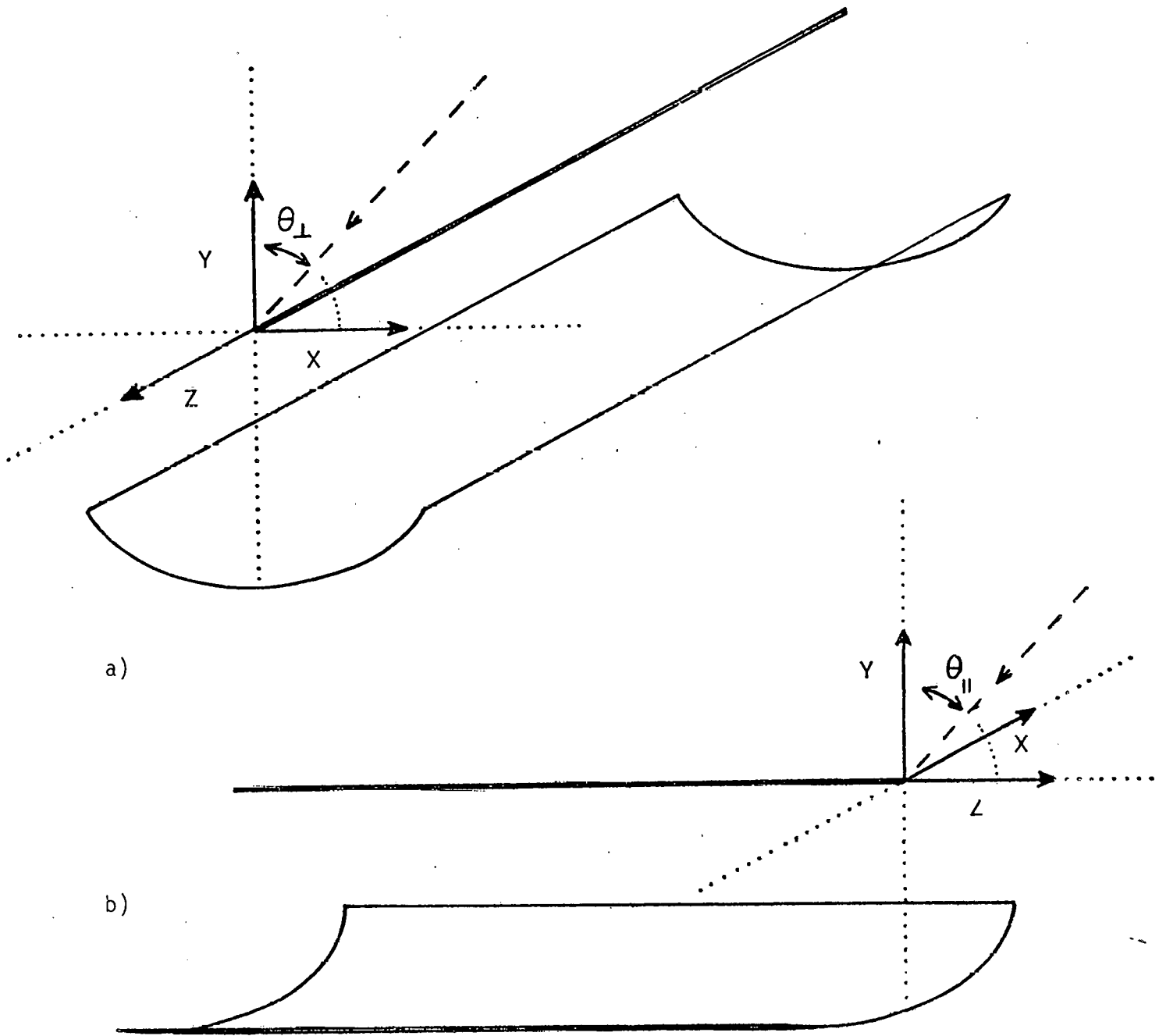

Fig. 2. Definition of the projected incidence angles θ_{\perp} (a), and θ_{\parallel} (b) for two-dimensional concentrators

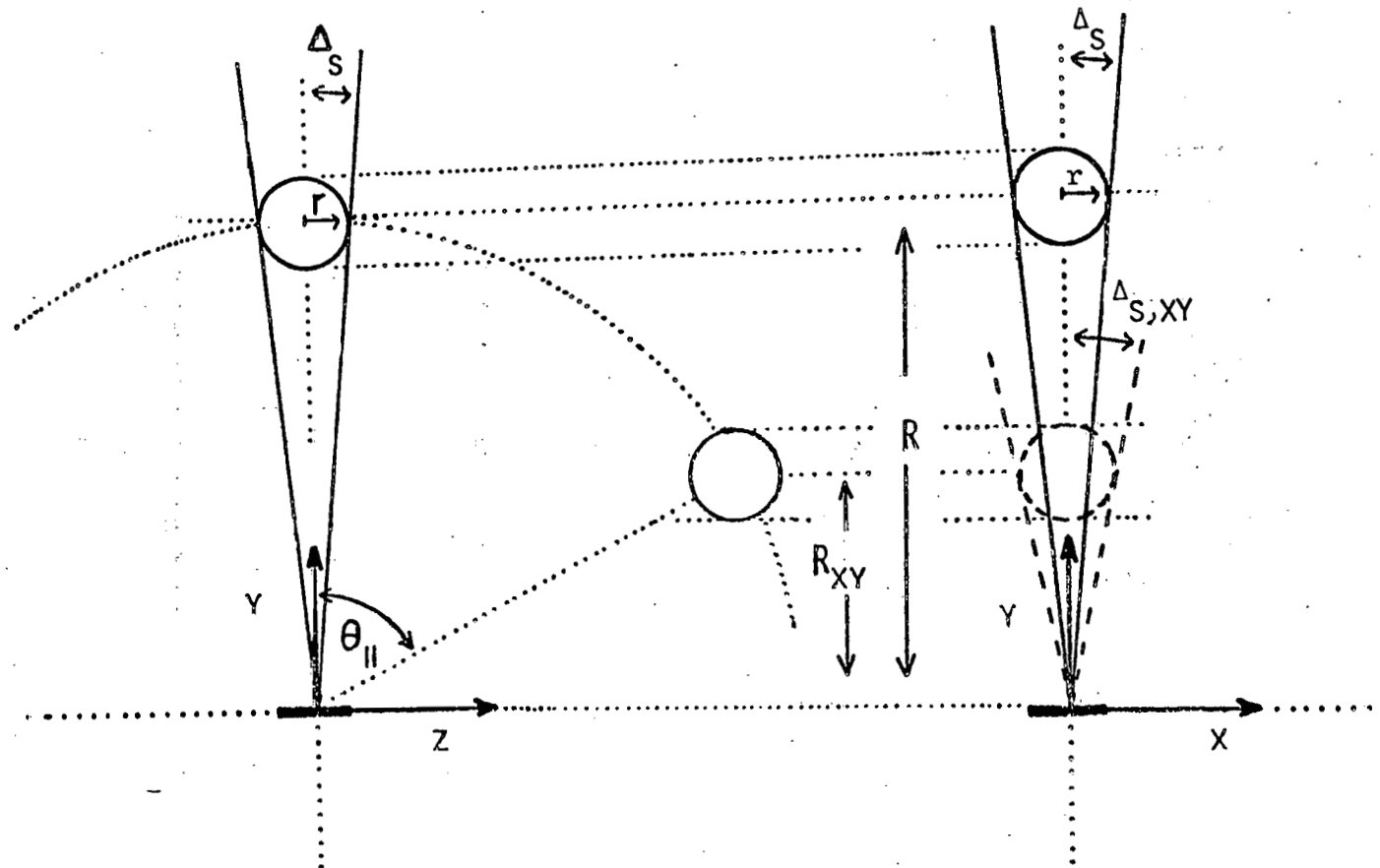

Fig. 2c. Increase in apparent solar width for two-dimensional concentrators at nonnormal incidence

collector. At noon, the sun is in the xy plane and the angular half width Δ_s of the sun is (note $\Delta_s \ll 1$)

$$\Delta_s = \frac{r}{R} \quad \text{with } r = \text{radius of sun} \quad (\text{II-3})$$

$$R = \text{distance earth-sun}$$

In the reference frame of the collector, the apparent diurnal motion of the sun is a circle of radius R around the earth; and therefore, away from solar noon, the projected angular half width of the sun in the xy plane is

$$\Delta_{s,xy} = \frac{r}{R_{xy}} = \frac{\Delta_s}{\cos \theta_{||}} \quad (\text{II-4})$$

where R_{xy} is the projection

$$R_{xy} = R \cos \theta_{||} \quad (\text{II-5})$$

of the sun-earth distance on the xy plane. For a concentrator with east-west axis, the projected angular width of the sun at four hours from noon will be twice as large as at noon.

B. TRACKING AND MIRROR ERRORS OF REFLECTING CONCENTRATORS

All mirror and tracking errors can be characterized by their angular standard deviation σ from the design direction. The standard deviation $\sigma_{\text{reflector}}$ resulting from all optical imperfections is obtained by adding the squares of the individual standard deviations expressed in equation form as:

$$\sigma_{\text{reflector}} = [(2\sigma_{\text{contour}})^2 + (2\sigma_{\text{tracking}})^2 + \sigma_{\rho}^2]^{1/2} \quad (\text{II-6})$$

for reflector systems, σ_ρ is the spread of the reflected ray due to imperfect specularity. Fresnel lenses, by contrast, are a factor 2 to 4 less sensitive to contour and tracking errors; see Section II C.

The finite angular radius $\Delta_{\text{sun}} = 1/4^\circ$ of the sun contributes further to beam spreading and the resulting total beam width for radiation from reflector or lens surface to the receiver is given by

$$\sigma_{\text{tot}} = [\sigma_{\text{sun,eff}}^2 + \sigma_{\text{reflector}}^2]^{1/2} \quad (\text{II-7})$$

Note that the standard deviation of the sun corresponding to its angular radius is

$$\sigma_{\text{sun}} = 1/2 \Delta_{\text{sun}} = 1/8^\circ \quad (\text{II-8})$$

for a line focus system. For troughlike concentrators, the effective angular width of the sun increases at nonnormal incidence and can be expressed by

$$\sigma_{\text{sun,eff}} = \frac{\sigma_{\text{sun}}}{\cos \theta_{\parallel}} \quad (\text{II-9})$$

where θ_{\parallel} is the solar incidence angle projected on the plane spanned by sun and trough axis as explained above. While this effect is negligible for polar mounted concentrators, it makes $\sigma_{\text{sun,eff}}$ twice as large as σ_{sun} four hours from solar noon in concentrators with east-west axis; hence, use of $\sigma_{\text{sun,eff}}$ is recommended in Eq. (II-6).

The simplest procedure for accounting for mirror errors is to first find σ_{tot} and then to choose the receiver size to give the system an acceptance half angle $\theta_c = 2\sigma_{\text{tot}}$ if the optics were perfect. This assures collection of at least 95% of the incoming rays. For high concentration systems, it may pay to further optimize the relation between acceptance angle and fraction of rays collected; but in low concentration systems, the role of error is less important and the

" 2σ is 95%" rule will usually be a good compromise. In fact, the large tolerance to manufacturing and tracking errors is one of the chief advantages of low concentration systems.

For nontracking concentrators, the rule for incorporating mirror errors is slightly different but equally simple: enlarge the design acceptance half angle of a perfect system by $2\sigma_{\text{tot}}$. This rule is justified by the fact that, in a CPC, all rays incident with $\theta_{\text{in}} = \theta_c$, i.e., at the cutoff angle, undergo exactly one reflection on their way to the receiver.

C. OPTICS OF FRESNEL LENSES

The optics of a refractive element (lens) differs in two important aspects from that of a reflective element (mirror): the off-axis aberrations and the effect of surface and tracking errors.

If the incident radiation is not parallel to the optical axis of a Fresnel lens, the focal length shortens; and, due to aberrations, the size of the focal spot increases. Fig. 3b shows the variation in focal length of a line focus Fresnel lens as a function of elevation θ_{\parallel} of incident direction from the plane of the paper in Fig. 3a. For a two dimensional concentration system (line focus or cylindrical geometry) with east-west axis, θ_{\parallel} changes from 0° (at noon) to $+60^\circ$ (at 4 pm); and the corresponding variation in focal length makes the use of Fresnel lenses impractical for this configuration.

On the other hand, in a system with polar tracking axis, the seasonal variation in θ_{\parallel} is less than $\pm 40^\circ$ for the same cutoff times; and a linear Fresnel lens can be used with low concentration ($C \leq 12$, or up to approximately 20 if a second stage concentrator is used). If higher concentration values (20 to 40) are to be reached with line focus Fresnel lens, the tilt of the tracking axis must be adjusted seasonally.

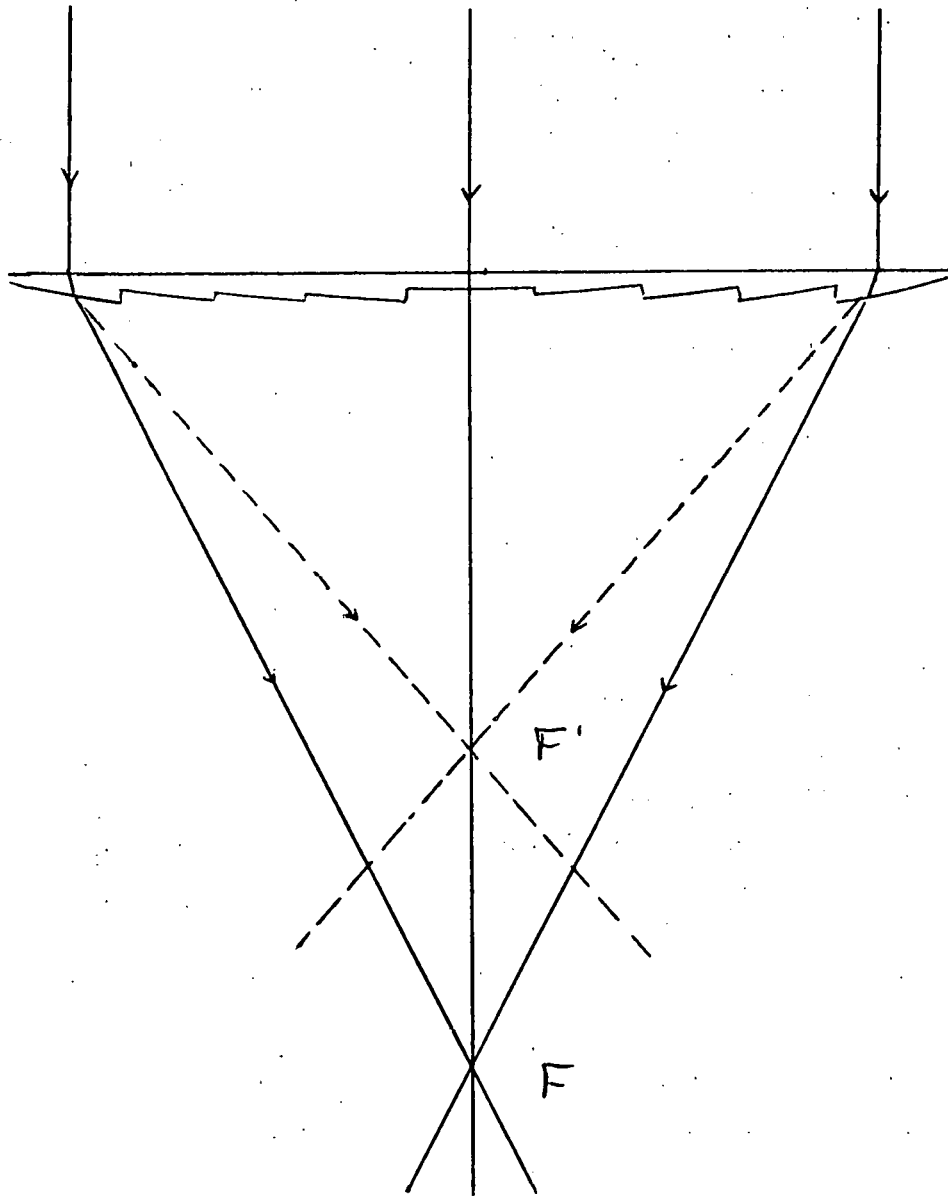

Fig. 3a. Off-axis aberration of linear Fresnel lens. Solid line: beam incident in plane of paper, focus F ; dashed line: beam not in plane of paper, focus F' .

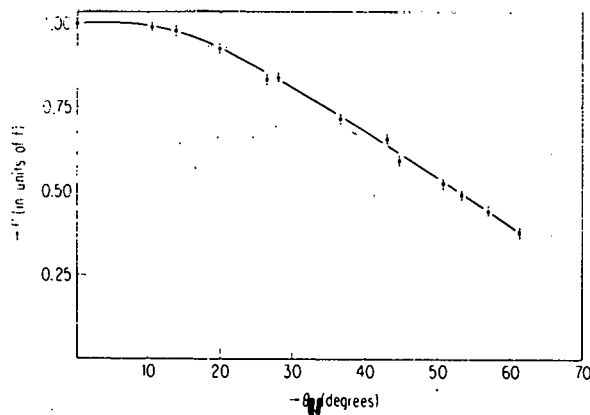

Fig. 3b. Change of focal length of linear Fresnel lens with nonplanar incidence

To understand the effect of tracking and contour errors in a lens, let us recall that, if the slope of a reflector element differs from the correct value by an angle Δ , the reflected ray will deviate from the design direction by 2Δ . In a Fresnel lens, on the other hand, the corresponding deviation from the design direction will be $(n-1)\Delta$ for rays passing through the center of the lens where n is the index of refraction. Near the edge of the lens the deviations will be somewhat larger; but, in general, a Fresnel lens is a factor 2 to 4 less sensitive to surface and tracking errors than a reflector. In practice, this effect will more than compensate for the chromatic aberrations of simple Fresnel lenses as compared to reflectors (which are inherently free from chromatic aberrations).

D. OPTICS OF GLASS TUBES

In order to reduce heat losses in solar thermal collectors, it may be desirable to enclose the absorber tube within a glass tube. The effect which refraction in the glass tube has on the optics of a solar concentrator can be determined by a simple method [7] which follows from the connection between rotational symmetry and angular momentum conservation. This is best expressed in terms of the impact parameter of a light ray, defined as shortest distance between the light ray and

the symmetry axis of the tube. In Fig. 4, the impact parameters r_0 , r_1 , and r_2 of the light ray R outside the tube, in the tube wall, and inside the tube, respectively, are related by

$$r_0 = nr_1 = r_2 \quad (\text{II-10})$$

if R is in the plane of the paper, and by

$$r_0 \sqrt{1 - s_z^2} = nr_1 \sqrt{1 - (s_z/n)^2} = r_2 \sqrt{1 - s_z^2} \quad (\text{II-11})$$

if R is nonplanar with z component s_z . If R would have been tangent to the absorber tube in the absence of the glass envelope, it will also be tangent to this absorber (at a different point) after passing through the envelope. Therefore, the concentration value of the whole system is not changed by the addition of an envelope. This result holds for both planar and for nonplanar rays and is independent of the index of refraction or the diameters.

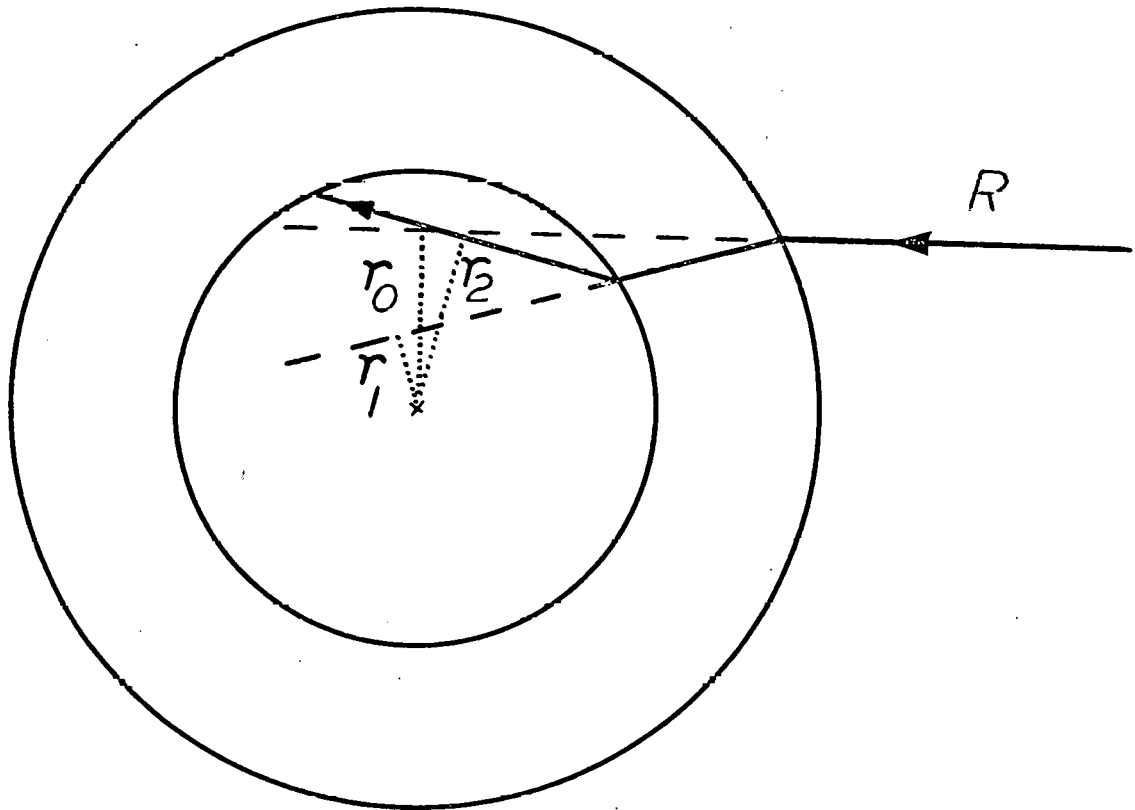

Fig. 4. Refraction of light ray by glass tube. The impact parameters r_0 and r_2 are equal.

III. RELATIONSHIP BETWEEN INSTANTANEOUS EFFICIENCY AND LONG-TERM AVERAGE ENERGY DELIVERY

A. PREDICTION METHODS

The performance of solar collectors is usually specified in terms of instantaneous or peak efficiency, based on clear days and normal incidence. In practical applications, however, one needs to know the long-term energy delivery averaged over all cloud conditions and incidence angles [8]. To fill this need, many researchers have advocated average diurnal efficiency as a collector performance measure. Unfortunately, such average efficiency curves may depend strongly on peculiarities of the weather for the test day and test location, and are therefore limited in their general applicability.

One approach to this problem is to use a computer program with instantaneous efficiency and hourly insolation data as input. Use of real data for a specific place and year provides a performance simulation for that place and year; it is reliable as prediction for the long-term average only if the weather data are representative of long-term weather behavior. After all, fluctuations in monthly total insolation from one year to the next commonly exceed +10%, and the resulting output fluctuations for thermal collectors are even larger.

Computer simulations require time, money, and expertise. Even though the computing time is inconsequential for a few sample simulations, the large number of parameters to be considered will make any meaningful system optimization or comparison study costly and time consuming. Furthermore, one gains little intuitive understanding of functional relationships.

As an alternative one can use a generalized Liu and Jordan model [9] which treats all collector types in a consistent manner and which needs, as meteorological input, only the long-term average daily total hemispherical irradiation \bar{H}_h on a horizontal surface as well as the long-term average daily ambient temperature \bar{T}_a . This information is readily available for a

large number of locations. The method is simple enough for hand calculations. In general, the seasonal variability of the weather will necessitate a separate calculation for each month of the year; however, one calculation for the central day of each month will be adequate. Long-term weather patterns are automatically included in such a model. Since the dependence on individual design variables such as tilt angle, concentration ratio, and operating temperature is displayed explicitly, it is easy to study the effect of changing any of these variables. The influence of climate and location can be assessed systematically. This gain in intuitive understanding can be of great help for system optimization and for comparison studies.

Whichever of these two long-term prediction methods is used, the collector characteristics must be measured and reported in a standardized format; the same format is suitable for both methods. In order for the calculation to be accurate, it is imperative that a sufficient number of collector parameters be measured [10,11]. Most important are the instantaneous efficiency η at normal incidence, the optical efficiency, η_o , the heat loss q_l , and the incidence angle modifier. For the operating temperature and insolation several choices are possible, and the following subsections give formulas for converting from one base to another (e.g., from receiver temperature to fluid inlet temperature, or from beam irradiation to hemispherical irradiation).

B. SPECIFICATION OF INSOLATION

Traditionally, the efficiency of flat-plate collectors has been referred to hemispherical (also called global or total) irradiation I_h , and that of tracking collectors to beam (also called direct) irradiation I_b . To convert from one base to another, it is appropriate to add subscripts to the efficiency. If q_{out} is the collector output [in W/m^2] relative to net collector aperture area A , then the efficiency with respect to hemispherical irradiation I_h is

$$\eta_h = \frac{q_{out}}{A I_h} \quad (III-1)$$

while the efficiency with respect to beam I_b is

$$\eta_b = \frac{q_{out}}{A I_b} \quad (III-2)$$

The conversion from one to the other is

$$\begin{aligned} \eta_b &= \eta_h \frac{I_h}{I_b} \\ &= \eta_h \left(1 + \frac{I_d}{I_b}\right) \end{aligned} \quad (III-3)$$

where $I_d = I_h - I_b$ is the diffuse component. Since efficiency measurements should always be done under clear sky, the ratio I_d/I_b of diffuse over beam is about 0.1 to 0.15. This means that the efficiency curve of a collector is at least 10% higher when stated in terms of beam rather than in terms of hemispherical radiation.

Collectors with low concentration $1 < C \lesssim 10$, e.g., CPC and V-trough, accept a significant fraction, $1/C$, of the diffuse component in addition to I_b , and the insolation available to them is

$$I_c = I_b + \frac{1}{C} I_d \quad (III-4)$$

For these collectors the efficiency may be stated relative to the irradiation I_c (i.e., irradiation within acceptance angle) as

$$\eta_c = \frac{q_{out}}{A I_c} \quad (III-5)$$

The conversion from η_c to η_h is

$$\eta_c = \eta_h \frac{1 + \frac{I_d}{I_b}}{1 + \frac{I_d}{CI_b}} \quad (III-6)$$

C. REFERENCE TEMPERATURE

Several collector temperatures can serve as reference for stating the efficiency, the most useful being

$$\begin{aligned} T_r &= \text{average collector receiver surface temperature} \\ T_{in} &= \text{fluid inlet temperature} \\ T_{out} &= \text{fluid outlet temperature} \\ T_f &= (T_{in} + T_{out})/2 = \text{average fluid temperature} \end{aligned}$$

To a very good approximation, only the difference between the collector receiver surface temperature and

T_a = ambient temperature matters. The heat loss coefficient or U-value U [in $W/m^2 \cdot ^\circ C$] is defined relative to collector aperture area A as

$$U = \frac{q_1}{A(T_r - T_a)} \quad (\text{III-7})$$

where q_1 is the heat loss [in W]. Strictly speaking, U is not constant; but its dependence on temperature, wind, and other environmental factors is fairly weak, and good approximation is obtained by using an average U-value corresponding to the anticipated operating temperature. For a better approximation we recommend Tabor's parameterization [11]

$$U = U_o (T_r - T_a)^p \quad (\text{III-8})$$

where p is a collector dependent coefficient, typically in the range 0.1 to 0.3 for nonevacuated collectors and somewhat larger for evacuated collectors. In terms of U the collector efficiency reads

$$\eta = \eta_o - U(T_r - T_a)/I \quad (\text{III-9})$$

if the average receiver surface temperature T_r is given. η_o is the optical efficiency or efficiency at zero heat loss; it has also been called $\tau\alpha$ product in the flat-plate literature.

Usually it is more practical to measure the fluid temperature than the receiver surface temperature. In terms of the average fluid temperature T_f the efficiency equals

$$\eta = F'[\eta_o - U(T_f - T_a)/I] \quad (\text{III-10})$$

where F' is the heat extraction factor (called collector efficiency factor in Ref. 12) given by the ratio

$$F' = \frac{U_{fa}}{U} \quad (\text{III-11})$$

the thermal conductance U_{fa} from fluid from ambient over the thermal conductance from receiver surface to ambient (in this equation both U values must refer to aperture area). If the fluid inlet temperature T_{in} is specified, the efficiency is

$$\eta = F_R[\eta_o - U(T_{in} - T_a)/I] \quad (\text{III-12})$$

with the heat removal factor [12]

$$F_R = \frac{\dot{m}c_p}{UA} \left[1 - \exp\left(-\frac{UAF'}{\dot{m}c_p}\right) \right] \quad (\text{III-13})$$

\dot{m} is the mass flow rate [kg/s] through the collector and c_p is the fluid heat capacitance [J/kg °C] at constant pressure. Finally, the dependence of efficiency on fluid outlet temperature T_{out} is given by a modification [13] of Eq. (III-12)

$$\eta = \frac{F_R}{\left[1 - \frac{F_R UA}{\dot{m}c_p} \right]} [\eta_o - U(T_{out} - T_a)/I] \quad (\text{III-14})$$

Any of the four expressions for efficiency, (III-9), (III-10), (III-12), or (III-14), can be used as starting points for the calculation of long-term average performance.

D. INCIDENCE ANGLE MODIFIERS

Measurements of instantaneous efficiency are usually carried out (and reported) at normal or nearly normal incidence. In actual operation, on the other hand, the incidence angle on any collector with less than full 2-axis tracking will vary over the course of the day and the year. Usually the optical efficiency decreases with large incidence angles because of increased reflection from cover glazing and because of geometric factors. This effect can be described by an incidence angle modifier $F(\theta_{EW}, \theta_{NS})$ which multiplies the optical efficiency η_o measured at normal incidence

$$\eta_o(\theta_{EW}, \theta_{NS}) = \eta_o F(\theta_{EW}, \theta_{NS}) \quad (\text{III-15})$$

This notation allows for different angular characteristics in the East-West and in the North-South directions for collectors with linear structures such as tubular collectors or CPC troughs. For flat-plate collectors, and for point focus collectors, the angular characteristics can be described by a single angular variable. Collectors differ widely in their angular characteristics. For a parabolic line focus collector with flat end reflectors, tracking about the polar axis, the variation of optical efficiency may be negligible. On the other hand, collectors such as the Owens-Illinois SUNPAK^(TM) collector show variations in excess of 20%.

For greatest accuracy of long-term performance predictions one should measure the functional dependence of $\eta_o(\theta_{EW}, \theta_{NS})$ on θ_{EW} and θ_{NS} . This variation can then be folded into hour-by-hour calculations.

It is, however, much simpler to replace $\bar{\eta}_o$ by its long-term average $\bar{\eta}_o$. In practice $\bar{\eta}_o$ should be determined by measuring the average day long efficiency on a clear day from $t = t_{c-}$ until $t = t_{c+}$

$$\bar{\eta}_o = \frac{\int_{t_{c-}}^{t_{c+}} dt \frac{q_{out}(t)}{A} \Big|_{T_r = T_a}}{\int_{t_{c-}}^{t_{c+}} dt I(t)} \quad (\text{III-16a})$$

with average receiver temperature T_r kept as close as possible to ambient T_a to minimize heat loss. If the condition $T_r = T_a$ cannot be satisfied, one must correct Eq. (III-16a) by adding the daily total heat loss calculated from the known U-value

$$\bar{n}_o = \frac{\int_{tc-}^{tc+} dt \left\{ \frac{q_{out}(t)}{A} + U[T_r(t) - T_a(t)] \right\}}{\int_{-tc-}^{tc+} dt I(t)} \quad (III-16b)$$

if the receiver temperature $T_r(t)$, and

$$\bar{n}_o = \frac{\int_{tc-}^{tc+} dt \left\{ \frac{q_{out}(t)}{AF_f} + U[T_f(t) - T_a(t)] \right\}}{\int_{tc-}^{tc+} dt I(t)} \quad (III-16c)$$

if the average fluid temperature $T_f(t)$ has been monitored.

Some angular scans which have been reported in the literature [14,15] are shown in Figs. 5 and 6.

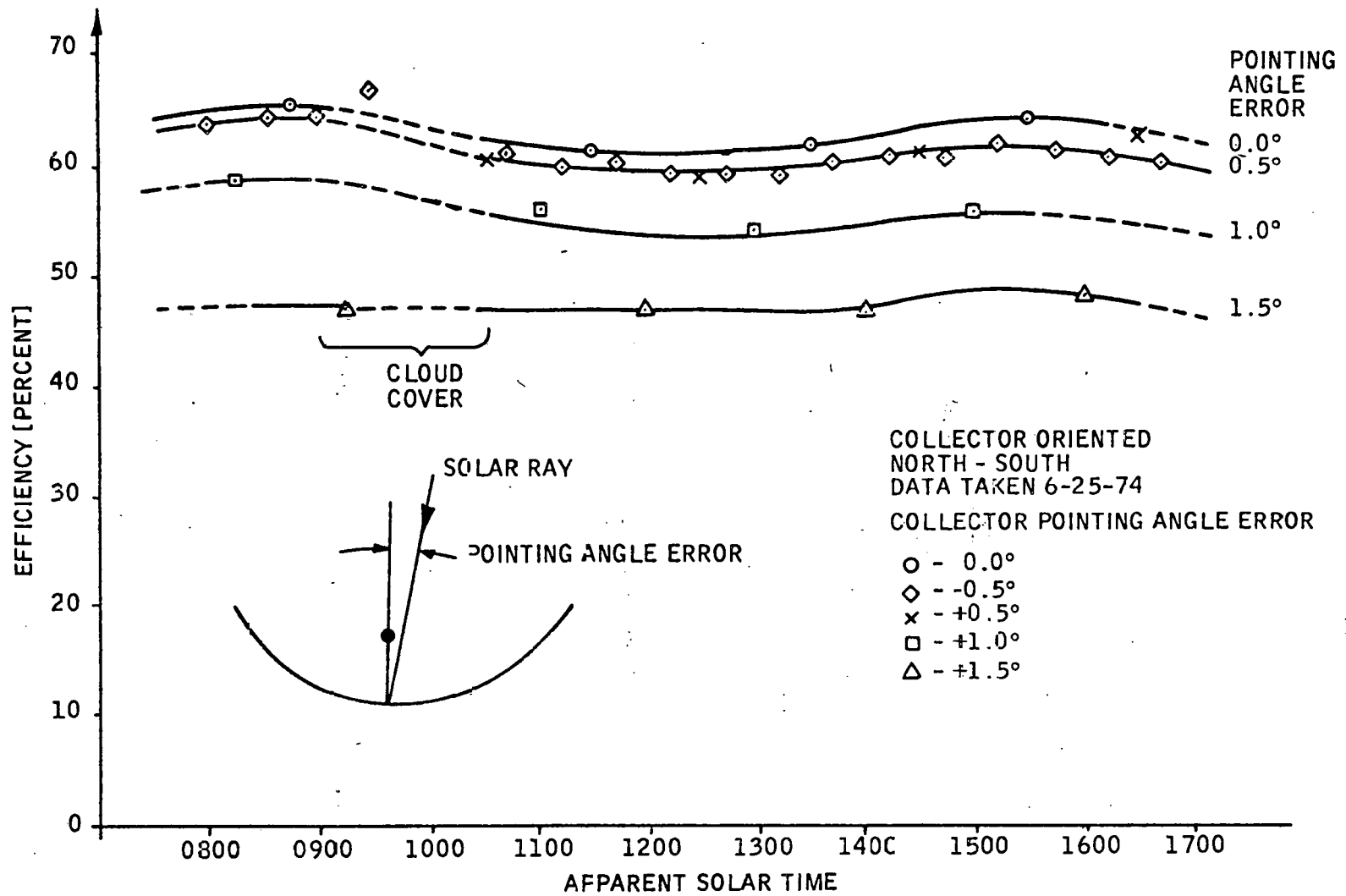
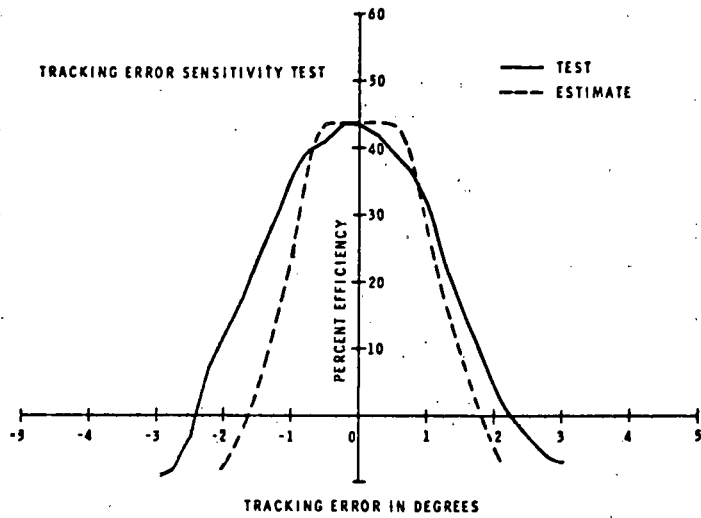
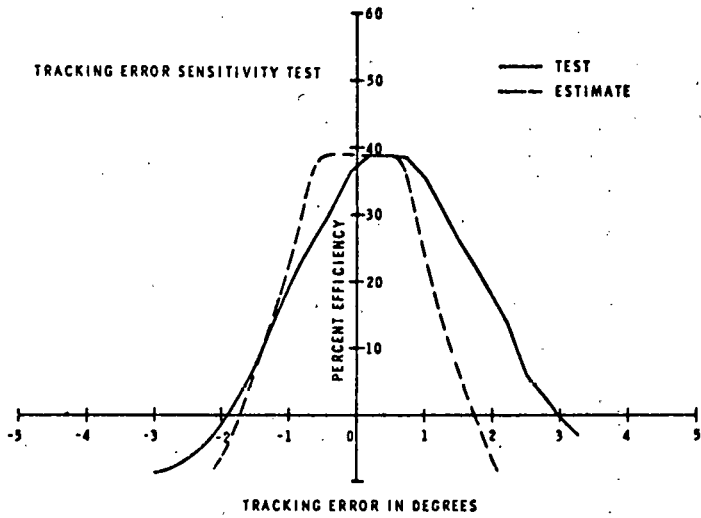

Fig. 5. Efficiency versus Time of Day for North-South Collector Orientation for Parabolic Trough, from Ref. 16.



Tracking Error Sensitivity Test, Southwest Quadrant



Tracking Error Sensitivity Test, Northwest Quadrant

Fig. 6. Angular scan for parabolic trough, from Ref. 15

THIS PAGE INTENTIONALLY LEFT BLANK

IV. PERFORMANCE OF SOLAR COLLECTORS WITH COMPOUND
PARABOLIC CONCENTRATORS AND EVACUATED RECEIVERS*

Compound parabolic concentrators (CPC, also called nonimaging concentrators) achieve the highest possible concentration permissible by the thermodynamic limit of concentration

$$C = \begin{cases} 1/\sin \theta_c & \text{for 2-dimensional or trough-like concentrators} \\ 1/\sin^2 \theta_c & \text{for 3-dimensional or cone-like concentrators} \end{cases}$$

consistent with a given acceptance half angle θ_c . For nontracking solar collectors with maximal concentration, one will use CPC troughs aligned in the east-west direction. It is reasonable to demand at least seven hours operating time [16,17] at solstice, the time of the year with the largest apparent solar motion; the corresponding concentration limit is 10 if tilt adjustments from one day to the next are permitted. A completely fixed collector can have a concentration ratio of 1.5 to 2.0. For some applications, collection of solar energy is required only during half of the year; in that case concentration of 3.0 becomes practical with a fixed collector.

The first example [18] of a CPC shown in Fig. 7 was found independently in the United States, Germany, and the U.S.S.R. about 1966. It consists of parabolic reflectors which funnel the radiation from aperture to absorber. The right and left half belong to different parabolas, as expressed by the name CPC. The axis of the right branch, for instance, makes an angle θ_c with the collector midplane, and its focus is at A. At the end points C and D, the slope is parallel to the collector midplane.

Subsequent to the discovery of the basic CPC, Fig. 7, several generalizations of the ideal concentrator have been described which are relevant for special applications. These generalizations concern

*Contributors to this work are J. Allen, N. Levitz, K. Reed, W. Schertz, of Argonne National Laboratory; J.O. Gallagher and R. Winston of the University of Chicago; and T. Peters of Chamberlain Manufacturing.

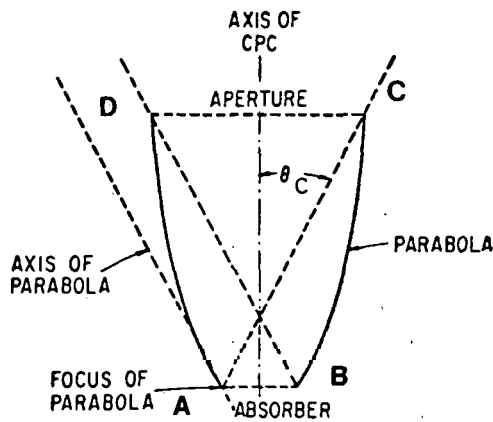

Fig. 7. Cross section of CPC with one-sided flat absorber.

- (i) the use of arbitrary receiver shapes [19,20] for example, fins and tubes (the latter being important because of their ability to carry a heat transfer fluid); see Fig. 8b and 8d.
- (ii) the restriction of exit angles θ_{out} at the receiver to values [21] $\theta_{out} < \theta_2 < \pi/2$ (important because some receivers have poor absorptivity at large angles of incidence); see Fig. 9.
- (iii) asymmetric orientation of source and aperture (for the design of collectors with seasonally varying outputs) [2].
- (iv) the matching of a CPC to a finite source of radiation [21] (second stage concentrators have to collect radiation from a source, the first stage, which is a finite distance away).

All of these reflector geometries are loosely referred to as CPC, even though some of them are not even parabolic. More generally, they may be classified as nonimaging concentrators.

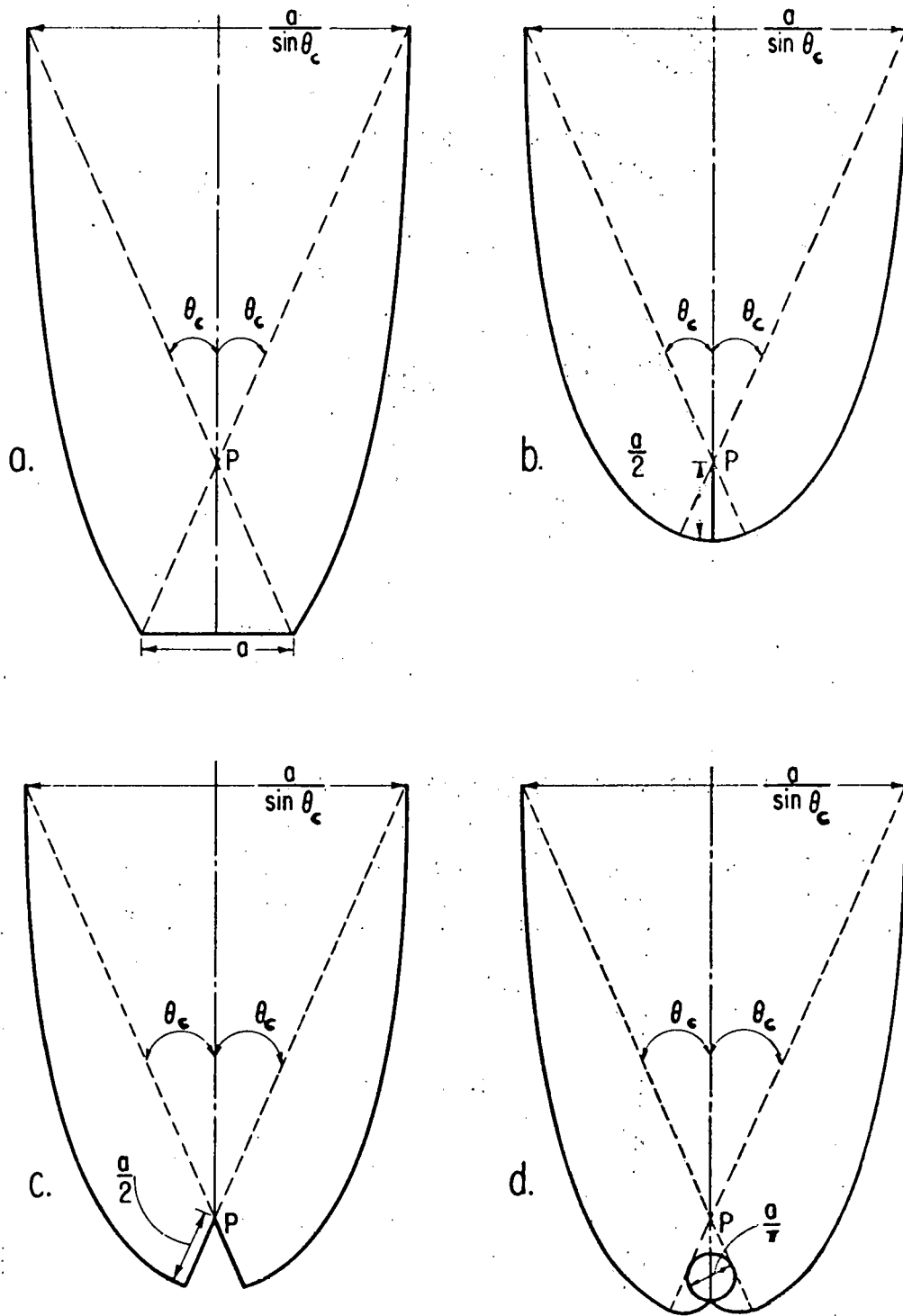
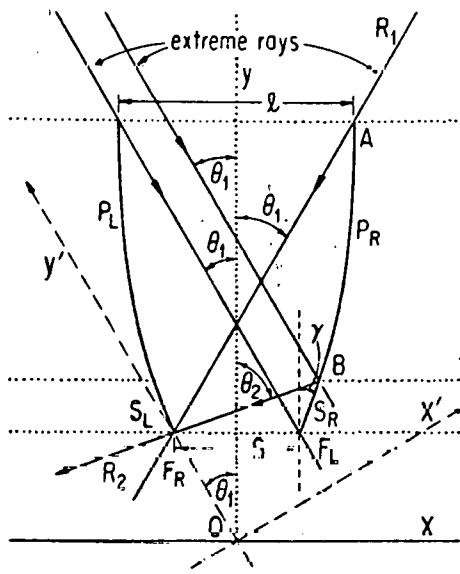

Fig. 8. CPC's for different absorber shapes:
 flat one-sided (a), fin (b), wedge (c), tube (d).



$\theta_1 - \theta_2$ transformer, consisting of parabolic section P_R and P_L and of straight sections S_R and S_L .

Fig. 9. CPC with restricted exit angles $|\theta_{out}| < \theta_2$.

- FULL CPC
- TRUNCATED CPC
- CPC WITH MIRROR ERROR Δ

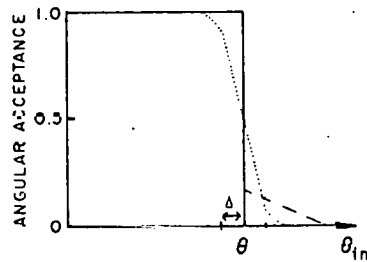

Fraction of the radiation incident on aperture at angle θ , which reaches absorber, for ideal concentrator in two dimensions, with acceptance half angle θ , assuming reflectivity $\rho = 1$.

- , untruncated ideal concentrator with perfect reflectors;
- , truncated ideal concentrator with perfect reflectors;
-, untruncated ideal concentrator with surface errors Δ .

Fig.10. Angular response of CPC (schematic).

As for the choice between different absorber types, the configuration with fin or tube absorbers, Fig. 8b and 8d, will be preferable for [22] most solar applications. Not only is the absorber material used more efficiently than in other designs, but heat losses through the back are low. This will more than compensate for the slightly higher optical losses (the average number of reflections for the configurations of Fig. 8b and 8d is about 0.5 higher than for the CPC of Fig. 7).

In their optical properties, all CPC types are exactly or almost exactly alike. Above all, they have the same relation between concentration and acceptance angle. All rays incident on the aperture within the acceptance angle, i.e., with $\theta_{in} \leq \theta_c$, will reach the absorber, while all rays with $\theta_{in} > \theta_c$ will bounce back and forth between the reflector sides and re-emerge through the aperture. This property is shown schematically by the solid line in Fig. 10.

In this paper, design, construction, and test results are reported for several different solar collectors with CPC reflectors and evacuated receivers. Concentration ratios of 1.5, 3.0, and 5.0 were chosen. (Five times concentration will necessitate about 12 tilt adjustments per year.) Concentration achieves two goals: it improves the high temperature performance, and it reduces collector cost where reflectors cost less than receivers.

The receivers are evacuated tubes, supplied by Corning Glass [23], by General Electric [24], and by Owens-Illinois [25]. Several techniques for low-cost manufacture of the reflectors have been evaluated, in particular vacuum formed plastic, roll formed aluminum sheet, epoxy impregnated fiberglass and aluminized mylar on urethane foam, and aluminized mylar on paper honeycomb. With all these processes, the resulting mirror surface quality was quite satisfactory in view of the large acceptance angle of the CPC. This fact is illustrated by the angular scan shown in Fig. 11. It is the measured angular response of a 1.5x CPC with roll formed aluminum sheet reflector and Owens-Illinois receiver. The most durable reflector is obtained by roll forming anodized aluminum sheet. Even with this process which is the most expensive of the ones considered, the projected cost [26] of the reflector assembly is

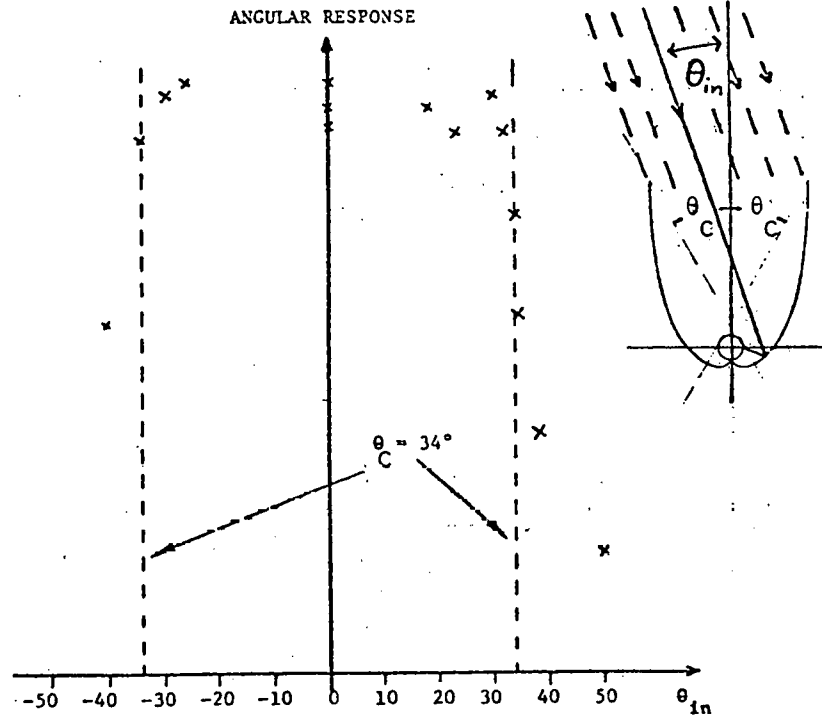

Fig.11. Measured angular response (relative units on y-axis) of 1.5x non-imaging concentrator.

only around $\$25/\text{m}^2$ of the collector aperture. With aluminized vacuum formed plastic, the reflector cost could be reduced to $\$5/\text{m}^2$.

The cross section of the Corning receiver (one-sided flat absorber) with its matching CPC reflector is shown in Fig. 12. The CPC configuration appropriate for the Owens-Illinois and for the General Electric receivers (tubular absorbers) is shown in Fig. 13. In order to prevent the accumulation of dirt and snow in the reflector troughs, we chose to cover the aperture of all collectors with a flat sheet of glass or acrylic. Even though such a cover causes reflection and absorption losses, it enhances the long-term performance by keeping the reflector clean. Furthermore, it allows the use of low-cost lightweight reflector structures which need not be protected against wind loading.

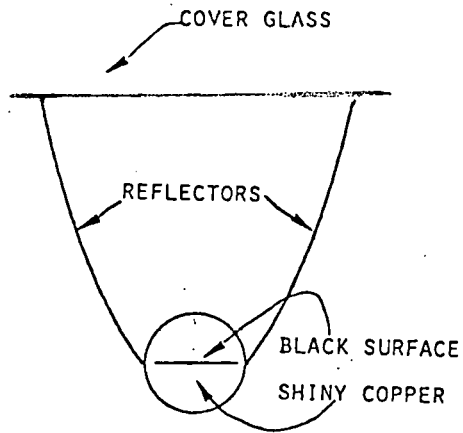

FIGURE 12. CROSS SECTION OF 3x CPC WITH CORNING RECEIVER

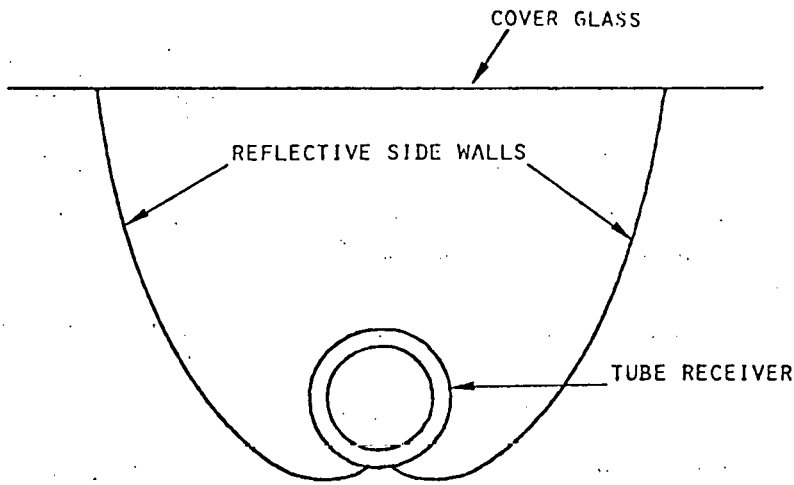

FIGURE 13. NONIMAGING 1.5x CONCENTRATOR COUPLED TO TUBULAR EVACUATED RECEIVER (GENERAL ELECTRIC OR OWENS-ILLINOIS)

The following collectors have been built and tested:

- (i) a 1.5x with General Electric receiver (i.e., geometric concentration ratio $C = 1.5$).
- (ii) a 1.5x with Owens-Illinois receiver.
- (iii) a 3x with Corning receiver.
- (iv) a 5x state-of-the-art version with Corning receiver.
- (v) a 5x advanced technology version with Corning receiver (etched glass used for cover and for receiver; silvered plastic film used for reflector).
- (vi) a 5x with Owens-Illinois tubes (but with heat transfer fluid loop modified to be like that of the General Electric receiver).

Test data for collector (i) are given in Fig. 14; they imply operating efficiencies above 40% at $T = 150^\circ\text{C}$ above ambient with a fixed collector. Note that the efficiency is stated in terms of total insolation on clear days. The quoted efficiency would be about 15% higher (dashed line in Fig. 14) if it were referred to direct insolation as is customary for most concentrators.

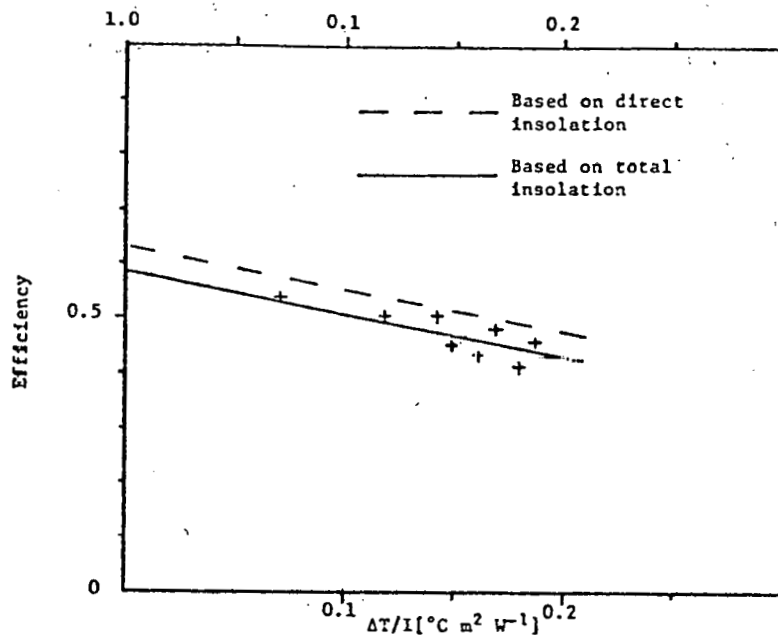

Fig. 14. Measured performance of fixed 1.5x nonimaging concentrator with General Electric receivers.

Data for a 5x CPC with Corning receiver are shown in Fig. 15, with efficiency referred to radiation within the acceptance angle. Two versions were tested, a state-of-the-art collector with untreated glass and aluminum reflectors, and an advanced technology version with etched glass and silvered reflectors. Etching of glass is a low-cost process which can increase specular transmittance by as much as 6 percentage points by reduction of reflection losses from the glass surfaces. By using etched glass [27] and silvered reflectors, the optical efficiency of a 5x CPC has been raised above 70%, as shown in Fig. 15. For the latter, the efficiency curve indicates operating efficiencies above 50% at 250°C, making this nontracking collector a suitable candidate for electric power generation in a total energy plant.

The state-of-the-art collectors, using aluminum reflectors and glass without antireflection surface treatment, have optical efficiencies in the range of 55% to 60%. Their U-values are on the order of $2/C \text{ W/m}^2 \text{ }^\circ\text{K}$ where C is the concentration ratio; the quoted U-value includes heat losses from the collector manifold. The collector efficiency factor F' (in the notation of Duffie and Beckman [12]) is better than 0.95; in other words, the difference between fluid and plate temperature does not significantly reduce the efficiency. This is due to the combination of vacuum and selective coating in collectors of this type.*

*For that reason, air is an excellent heat transfer fluid for evacuated collectors with selective absorbers.

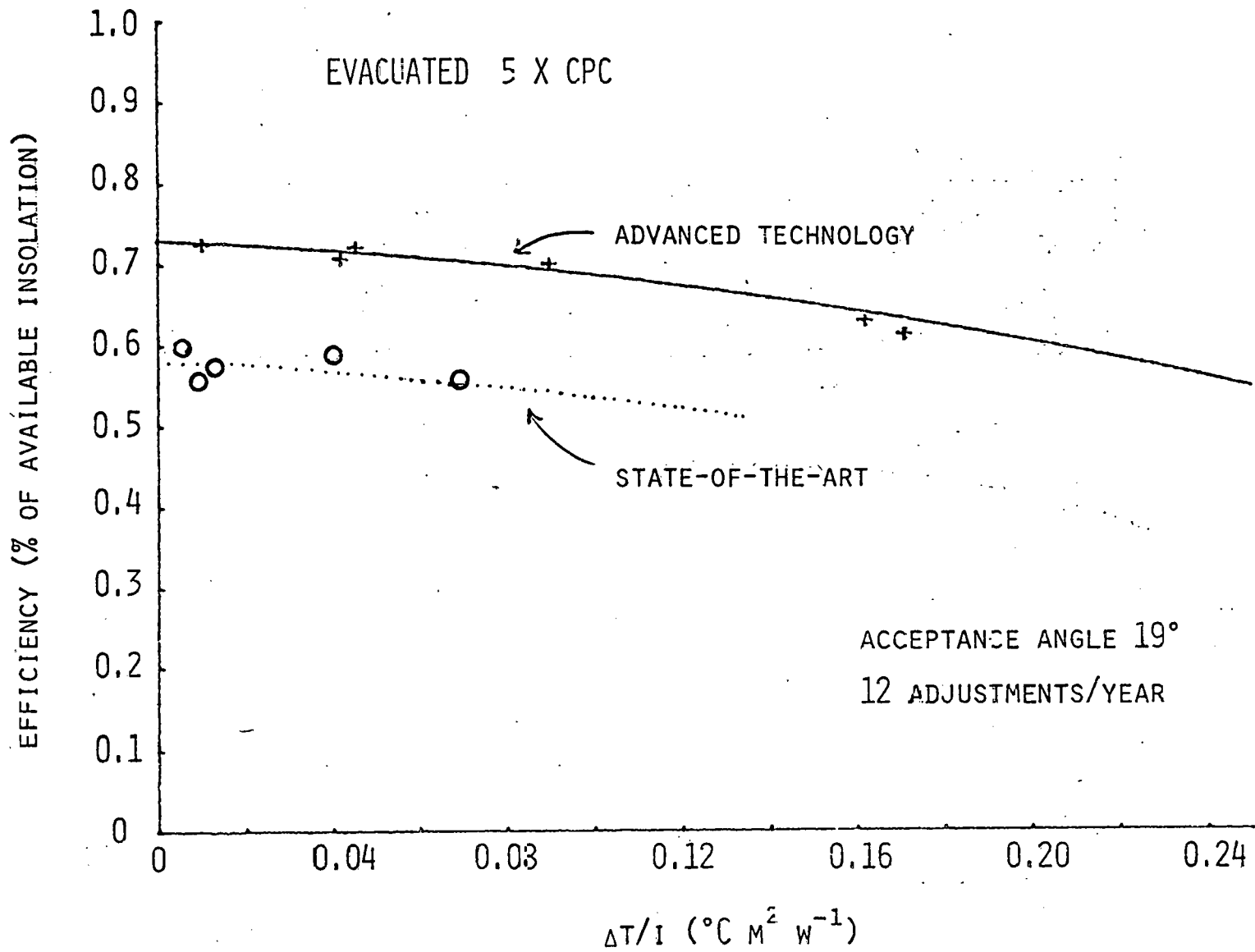

Fig. 15. Efficiency of 5X CPC.

V. REFERENCES

1. R. Winston, "Light Collection within the Framework of Geometrical Optics," J. Optic. Soc. Am., 60, 245 (1970).
2. A. Rabl, "Comparison of Solar Concentrators," Solar Energy, 18, 93 (1976).
3. J. L. Russell, Central Station Solar Power. Power Engng. (Nov. 1974). G. H. Eggers, et al., General Atomic Report GA-A14209 (Rev.) UC-62.
4. Grether, D. F., Hunt, A., Wahlig, M., Results from Circumsolar Radiation Measurements, Proceedings of the Joint Canada-American Conference, ISES, Vol. 1, p. 363, 1976.
5. K. R. Reed, "Instrumentation for Measuring Direct and Diffuse Insolation in Testing Thermal Collectors," Optics in Solar Energy Utilization II, SPIE (1976), Vol. 85.
6. Dr. K. R. Reed, private communication.
7. A. Rabl, "A Note on the Optics of Glass Tubes," Solar Energy 19, 215 (1977).
8. B. Y. H. Liu and R. C. Jordan, "A Rational Procedure for Predicting the Long Term Average Performance of Flat-Plate Solar-Energy Collectors," Solar Energy 7, 53 (1963).
9. M. Collares-Pereira and A. Rabl, "Simple Procedure for Predicting Long Term Average Performance of Nonconcentrating and Concentrating Solar Collectors," Argonne National Laboratory Report ANL-78-67, to be published in Solar Energy.
10. J. E. Hill and E. R. Streed, "A Method of Testing for Rating Solar Collectors Based on Thermal Performance," Solar Energy 18, 421 (1976). F. F. Simon, "Flat Plate Solar Collector Performance Evaluation with a Solar Simulator as a Basis for Collector Selection and Performance Prediction," Solar Energy 18, 451 (1976).
11. H. Tabor, "Testing of Solar Collectors," Solar Energy 20, 293 (1978).
12. J. A. Duffie and W. A. Beckman, "Solar Energy Thermal Processes," John Wiley & Sons, New York, 1974. Frank Kreith and Jan F. Kreider, "Principles of Solar Engineering," McGraw-Hill, New York, 1978.
13. F. deWinter, "Heat Exchanger Penalties in Double-Loop Solar Water Heating Systems," Solar Energy 17, 335 (1976).
14. J.W. Ramsey, B.P. Gupta and G.R. Knowles, "Experimental Evaluation of a Cylindrical Parabolic Solar Collector," American Society of Mechanical Engineers, 76-WA/HT-13 (1976).

15. Sandia Report SAND 76-0662 (April 1977).
16. H. Tabor, "Stationary Mirror Systems for Solar Collectors," Solar Energy 2, 27 (1958).
H. Tabor, "Mirror Boosters for Solar Collectors," Solar Energy 10, 111 (1966).
17. R. Winston, "Solar Concentrators of a Novel Design," Solar Energy 16, 89 (1974).
18. V. K. Baranov and G. K. Melnikov, Soviet Journal of Optical Technology 33, 408 (1966).
H. Hinterberger and R. Winston, Rev. Sci. Instr. 37, 1094 (1966).
M. Ploke, "Lichtfuehrungseinrichtungen mit starker Konzentration-
swirkung," Optik 25, 31 (1967).
19. R. Winston and H. Hinterberger, "Principles of Cylindrical Concentrators for Solar Energy," Solar Energy 17, 255 (1975).
20. A. Rabl, "Solar Concentrators with Maximal Concentration for Cylindrical Absorbers," Applied Optics 15, 1871 (1976).
21. A. Rabl and R. Winston, "Ideal Concentrators for Finite Sources and Restricted Exit Angles," Applied Optics 15, 2880 (1976).
22. A. Rabl, N. B. Goodman, and R. Winston, "Practical Design Considerations for CPC Solar Collectors," (Jan. 1977), to be published in Solar Energy.
23. U. Ortabasi and W. M. Buehl, Analysis and Performance of an Evacuated Tubular Collector, Presented at ISES Conference in Los Angeles, Calif., (July 1975).
24. R. Bingman, Final Report for Contract 31-109-38-3805, General Electric Space Division (1977).
25. D. C. Beekley and G. R. Mather, Jr., Analysis and Experimental Tests of High Performance Tubular Solar Collectors, ISES Conference in Los Angeles, Calif., (July 1975).
26. Estimate of Reflector Cost by Chamberlain Manufacturing Corporation, Waterloo, Iowa 50705, USA.
27. R. E. Peterson and J. W. Ramsey, "Thin Film Coatings in Solar-Thermal Power Systems," J. Vac. Sci. Technol., 12, 174 (1975).

Dup

LINEAR CONCENTRATING SOLAR COLLECTORS--
CURRENT TECHNOLOGY AND APPLICATIONS*

James A. Leonard
Sandia Laboratories
Albuquerque, New Mexico 87185

ABSTRACT

This report surveys linear concentrating collector technology. Included are fundamentals of the technology; descriptions of collectors with particular emphasis on the types tested at the DOE/Sandia Midtemperature Solar Systems Test Facility (MSSTF); performance test results; problems identified through operating experience; cost projections; and a discussion of applications of linear concentrating and midtemperature solar collectors.

*This work supported by the US Department of Energy

Introduction

The objective of the Dispersed Power Systems Program within the Department of Energy's (DOE) Division of Solar Technology is to foster research and development for large-scale commercial implementation of dispersed solar thermal power systems. This comprises irrigation pumping, solar total energy systems, small (less than 10 MW) solar electric power plants, and high-temperature process heat applications. The word "dispersed" distinguishes between applications in which the solar plant is located at the point of use, and centralized (or utility) applications in which a large solar electric power plant serves a grid-connected, widespread market.

Sandia Laboratories manages Solar Total Energy and Irrigation, while the Jet Propulsion Laboratory of Pasadena, California, manages Small Power Systems Applications. Sandia also has two other closely related projects in support of Dispersed Power Systems. These are the Application Technology Development (ATD) project and the Midtemperature Solar Systems Test Facility (MSSTF).

The objective of ATD is the development of components and subsystems and the generation of technical data. This includes materials and process investigations, development of operation and maintenance (O&M) expertise, and characterization and measurement techniques development.

The primary objective of the MSSTF project is to support the application projects of the Dispersed Power Systems Program by:

1. providing a facility sufficiently versatile to be used as an engineering evaluation center or test bed for solar energy components and subsystems,
2. providing realistic system design and integration experience,
3. generating performance and cost data on components and subsystems,
4. accumulating O&M experience,
5. developing expertise in the private sector, including "hands on" experience, and
6. distributing mechanical, cost, and maintenance

information gained from the testing to potential developers and users of solar energy.

The ATD and MSSTF projects together support the application projects of the Dispersed Power Systems Program. Components are developed in ATD based on projected requirements of DOE or commercial application projects--the real installations in the real world. The MSSTF is utilized as a test bed to evaluate these components and to identify, through operating experience, areas requiring additional research and development.

A major activity within both the ATD and MSSTF projects is to develop and evaluate concentrating solar collectors that are efficient at elevated temperatures. Line-focusing collectors constitute the vast majority of concentrators now in service and the type with which Sandia has the most experience. The rest of this report surveys linear concentrating collectors, their performance capabilities, cost projections, and applications.

Linear Concentrating Collector Fundamentals

The fundamental operating concept of all line-focusing solar collectors is the same--solar radiation incident on a concentrating device is concentrated on a receiver through which a heat-transfer fluid flows. The concentrator may be either a reflector or a lens. The receiver is usually round tubing or pipe, but some designs employ non-round cross sections. Although the heat-transfer fluid may be either liquid or gas, no designs using gas are presently in field service.

Except for industrial process heat, all dispersed power system applications involve thermodynamic processes and are therefore subject to Carnot's laws, suggesting that high temperatures are advantageous. These applications will be discussed in more detail later in the report. While collectors designed for high-temperature operation can be considered for lower temperature applications,

the reverse may not be true. A geometric concentration factor of 25 or above is typical of collectors designed for high-temperature operation. Many excellent, cost-effective, concentrating collectors are marketed in the 10 range, but this discussion is limited to collectors designed for operation at temperatures above 235°C. Most of these are, in fact, designed for 300°C. Above this temperature two materials limitations, heat-transfer fluids and selective absorber coatings, presently constrain the technology.

All high-concentration line-focusing collectors track the sun throughout the day to maintain the sun's image on the receiver. Most reflective concentrators track in one axis only because the sun's position is critical relative to the concentrator's cross section only and need not be normal to the longitudinal axis. Collectors may be oriented along an east-west longitudinal axis and track the sun's elevation angle, or along a north-south axis and track the sun in azimuth. Lens concentrators differ from reflectors in that they must track the sun in two axes so that the incident solar radiation is normal to the focal plane of the lens. Nonnormality in the longitudinal axis reduces focal length and correspondingly reduces energy density at the receiver tube.

Throughout the following descriptions of collectors, reference is made to the reflecting surface. Three families of materials--polished metals, metallized films, and silvered glass--are generally employed.

Polished metals typified by Alcoa's Alzak and Kingston Industries' King Lux are moderately expensive (approximately \$20.00/m²) but are very durable, stable over long exposure times, are easily procured in sheet form, and can readily be bent and fastened to a curved substrate. The specular reflectance characteristics of these materials are their major drawback. Although these materials have a total hemispherical reflectance of about 0.85, their specular reflectance to a 10 mrad receiving aperture is only about 0.70.

Metallized films include aluminized and silvered Mylar, Teflon, and acrylic. These reflectors are available under many trade names and a wide price range (\$0.75 to \$3.00/ft² projected cost for high volume production). These materials may be used either as front-surface or back-surface reflectors. If used in a back-surface reflector configuration, the polymeric film must be ultra-violet resistant as are acrylic or Teflon. If used in the front surface configuration, the reflective material must be coated or otherwise protected from environmental degradation. Metallized films are frequently laminated to a secondary film for strength, toughness, or backside protection for the metallic surface. The films may be bonded directly to the concentrator structure or to sheet metal for subsequent attachment to the structure.

Major advantages of metallized films are their light weight, availability, and optical properties which allow specular reflectance (for material properly applied) to approach theoretical values for aluminum or silver. Disadvantages include the difficulty of bonding the films to a substrate without "print-through" of anomalies in the bonding agent or surface irregularities; susceptibility of the surface to damage, both from windblown particles and from inadvertent handling mishaps; and the difficulty of cleaning the polymeric surface. Cleaning techniques developed at Sandia Laboratories to date indicate that any mechanical cleaning method causes surface scratching which results in gradually worsening specular reflectance. Various liquid solvent jet methods appear satisfactory except that as-washed specular reflectance values fall below virgin material values by up to 5%.

Silvered Glass. Glass mirrors probably represent the optimum in performance potential for reflective concentrators. High quality, silvered glass in common (2-3 mm) thicknesses can be readily procured for about \$1/ft² in flat sheets. Unfortunately, flat sheets are not of interest to the designers of solar concentrators except for those concepts which employ relatively small flat facets such as the Fixed Mirror Solar Collector, discussed below.

Glass of common thickness can be bent only to very large radii which are applicable to central receiver applications but not to distributed collectors. Glass can be sagged to any shape (including compound) as in windshields and telescope mirrors, but unit costs are high for low quantities because of tooling and labor costs. The automotive industry amortizes tooling and automated production costs over millions of units.

Description of MSSTF

Most of the linear concentrating collectors described have been installed and evaluated at the MSSTF, either in the System Test Facility (STF), or in the Collector Module Test Facility (CMTF).

The STF (Fig. 1) consists of solar collector fields, high- and low-temperature thermal storage facilities, an electrical power generation subsystem, a lithium-bromide absorption air conditioner, an instrumentation and control system, a weather station, and a cooling tower. The STF can produce 32 kWe and about 200 kWth. As an exercise in operating system feasibility, this energy can be supplied to a nearby 1100 m² office building. The STF emphasizes investigation of the integration and performance of arrays (or fields) of collectors, and the interface tradeoffs and control problems of operating all elements of a solar energy plant. For instance, in addition to peak performance tests, comprehensive system-level tests are conducted. Some of these are all-day efficiency, receiver tube losses, vacuum vs. no-vacuum, sun sensor vs. computer tracking, tracking system sensitivity, concentrator surface mapping, automatic defocus, dirt effects, aging effects, parasitic power, fluid control strategy evaluations, early morning startup, parallel collector string control, and pipeline field heat losses.

The CMTF (Fig. 2) obtains thermal and optical performance data for prototype collectors. This facility presently incorporates three separately controlled fluid loops capable of testing three different

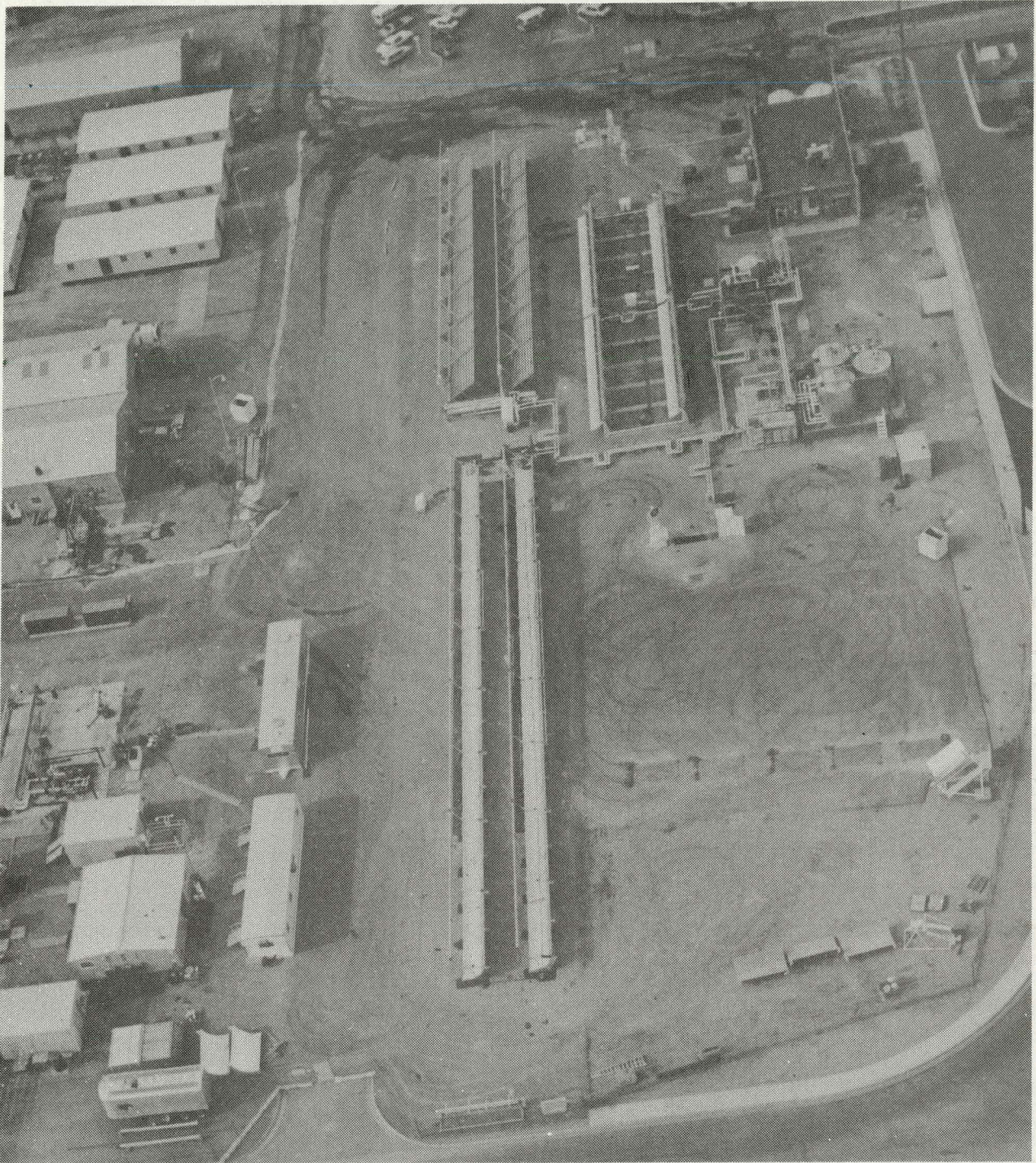

FIGURE 1. Midtemperature Solar Systems Test Facility

collectors simultaneously. The three test stations use Therminol-66 heat-transfer oil to 315°C, high-pressure water to 330°C and 18.3 MPa, and low-pressure water to 110°C and 0.51 MPa. This latter loop is

being modified to provide additional capability to test with heat-transfer oils to 425°C.

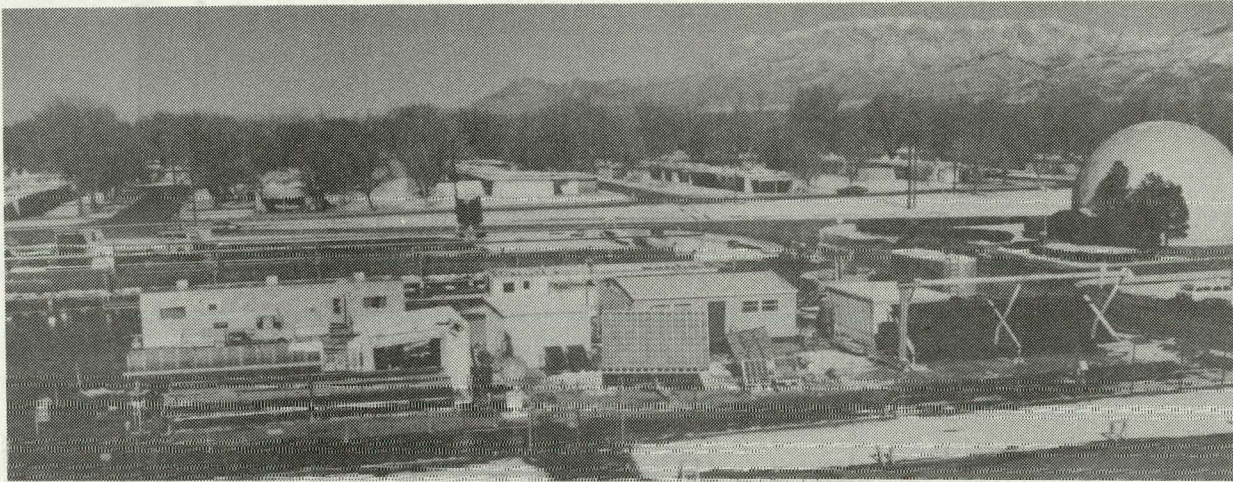

FIGURE 2. Collector Module Test Facility

The prototype collectors tested at the CMTF may be procured as the result of a DOE-sponsored development contract; may be purchased solely for the purpose of evaluating them to broaden the data base available to designers; or, if mutual benefit can be established, may be provided by industry for testing at government expense. Collectors tested during FY78 include modules from Del-Jacobs, FMC, GE, General Atomic, Hexcel, Itek, McDonnell Douglas, Scientific Atlanta, Solar Kinetics, Soltrax, and Suntec Systems. From 3 to 10 weeks are required to complete testing of a collector module, depending on the weather, the nature of the collector, and the complexity of the test plan. After each test, a report is issued to wide distribution. These reports are assembled into a summary report semiannually.

The primary purpose of all collector tests at the CMTF is to determine the peak performance capability of the collector module from about 150°C to 300°C. The collectors are carefully adjusted and cleaned before testing and are tested at performance

optimized flow rates and at near-normal solar incidence angles. Test sequences are designed to minimize degradation. The efficiencies thus derived may, therefore, be considered to be upper bounds. Of nearly equal importance are thermal loss tests to determine the capability of receiver tube designs. A typical test series may also include tests of "secondary" importance such as all-day efficiency, tracking system performance, effects of turbulence plugs, dirty vs. clean performance, vacuum vs. no-vacuum performance, and various other parametric or off-design tests.

Current Linear Concentrating Collector Technology

Six concentrating solar collectors have been evaluated at the CMTF since August 1977, when refurbishing and expansion of the Facility was completed. Two of these, the SLATS collector by Suntec Systems, Inc. and the Fixed Mirror Solar Collector by the General Atomic Co. (GA) were prototypes of collector field subsystems being designed and fabricated for installation in the Systems Test Facility. Three others--a parabolic trough by the Hexcel Corporation, a parabolic trough by Solar Kinetics, Inc., and a fixed mirror collector by Scientific Atlanta--were purchased as the result of a competitive procurement to buy collectors for evaluation. The sixth collector was a line-focusing Fresnel lens collector by McDonnell Douglas Astronautics Company (MDAC). This collector module was fabricated as the end-item of a complete development contract awarded MDAC to design, analyze, build, and test their Fresnel lens collector concept. The Suntec SLATS collector was tested on the high-pressure water loop, while the other five modules all employ Therminol-66 as a heat-transfer fluid and were tested accordingly.

The General Atomic Fixed Mirror Solar Collector¹ (FMSC) employs a precision cast concrete base configured of 5-cm longitudinal facets arranged along a circular cross section (Fig. 3). Silvered glass strips are bonded to the facets. The concrete base is 7.2 m

long and has an aperture width of 2.6 m. Reflected solar radiation forms a focal line above the concentrator; this line moves on a circular arc with the sun. A movable overhead receiver follows this

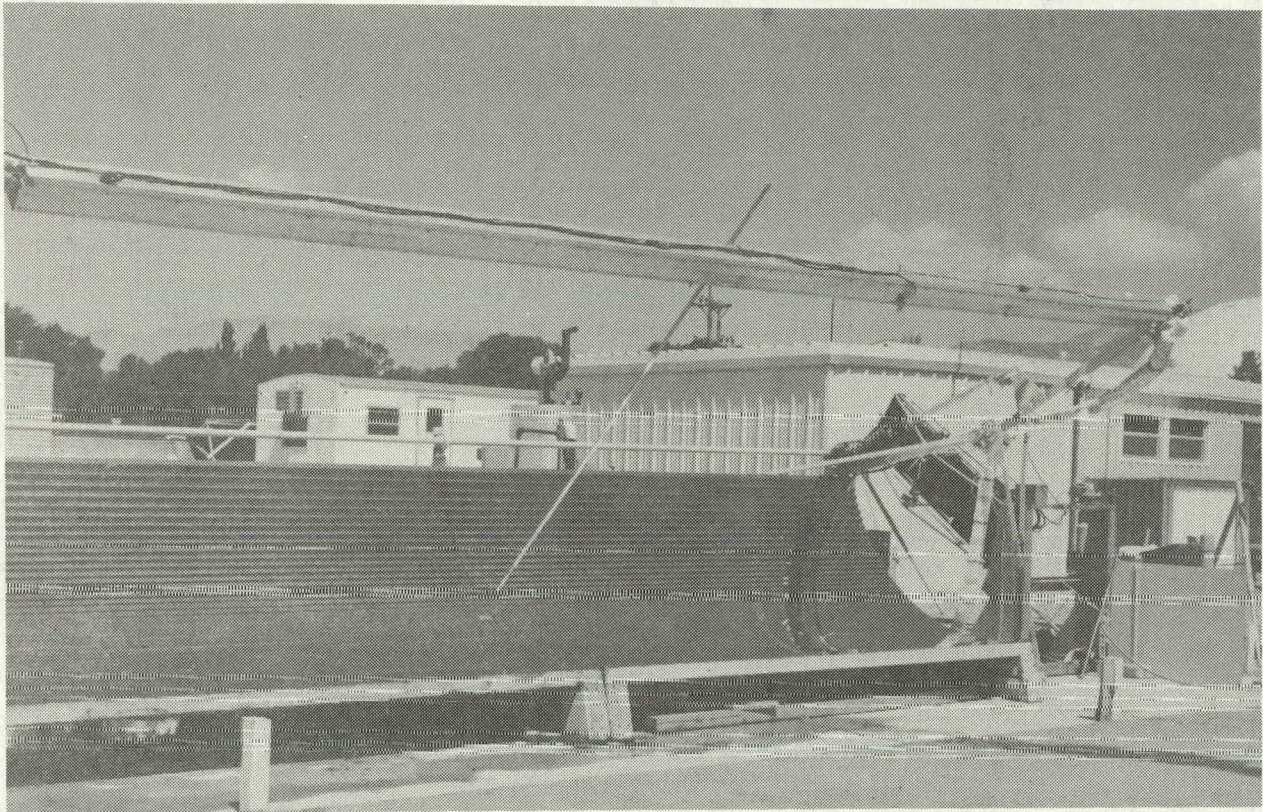

FIGURE 3. General Atomic Fixed Mirror Solar Collector

focal line throughout the day. The receiver assembly consists of flattened steel tubing. The receiver is electroplated with black chrome, a "selective" absorptive coating which has high absorptance over the solar spectrum but low emittance to minimize radiation losses. On the back side the tube is insulated with Microtherm, a silica-foam insulation. The receiver features a polished aluminum secondary concentrator extruded to a compound parabolic shape. At the base of the secondary concentrator is a Teflon window to reduce convective losses.

The Hexcel Corporation has developed a parabolic trough collector² which features aluminum honeycomb concentrator structures (Fig. 4). The module tested at Sandia Laboratories

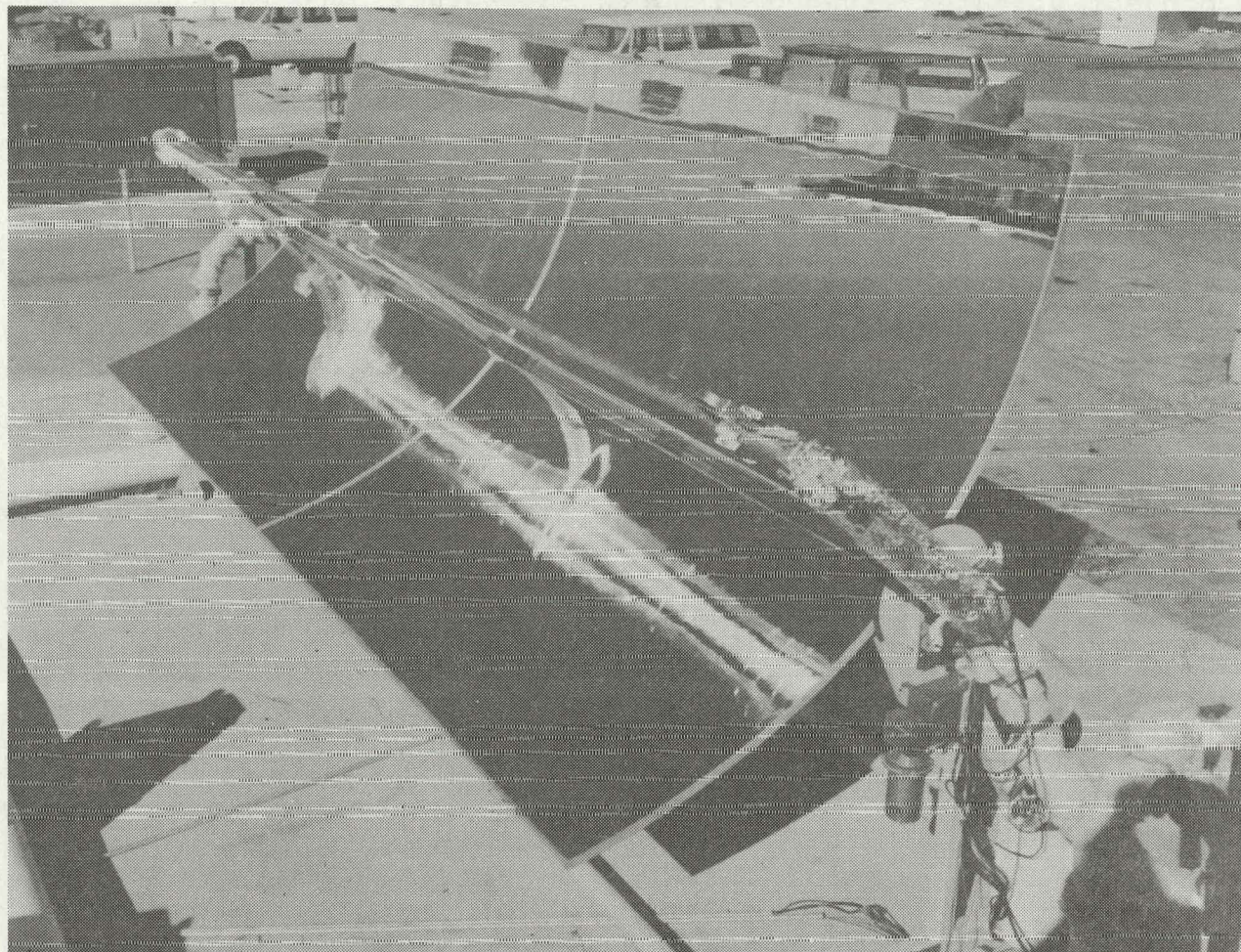

FIGURE 4. Hexcel Parabolic Trough Collector

has an aluminized acrylic film, reflective surface of FEK-163, and an adhesive-backed product developed by the 3M Company for solar application. The concentrator is 7.7 m long with an aperture of 2.6 m and a rim angle of about 70° . The collector is oriented east-west. The honeycomb structure is hinged at the longitudinal axis of the collector to permit some adjustment of the image after installation. The receiver tube is a black-chromecoated steel pipe. The unilluminated side of the receiver is insulated by a double wall cylindrical steel assembly filled with bulk insulation. On the absorbing side of the receiver a non-evacuated glass semi cylinder

interfaces with the steel insulating jacket to minimize convective losses. About 450 m² of an earlier version of the Hexcel collector was installed at Gila Bend, Arizona, in 1977 in a solar irrigation project privately funded by Northwest Mutual Life Insurance Company.

The McDonnell Douglas Fresnel lens collector³ is a prototype of a module which will be deployed in a much larger size--perhaps up to 100 m². The model tested at Sandia (Fig. 5) consists of an aluminum box-shaped structure 5.9 m x 3.6 m x 1.1 m deep. The upper surface of the structure supports four rows of cast-acrylic line-focusing Fresnel lenses. These lenses focus solar radiation on four rows of series-connected receiver tubes mounted in the base of the structure. The receiver tubes are black-chrome-coated steel pipes insulated on the underside by fiber-glass encased in glass cloth "pillows." On the illuminated side the receiver

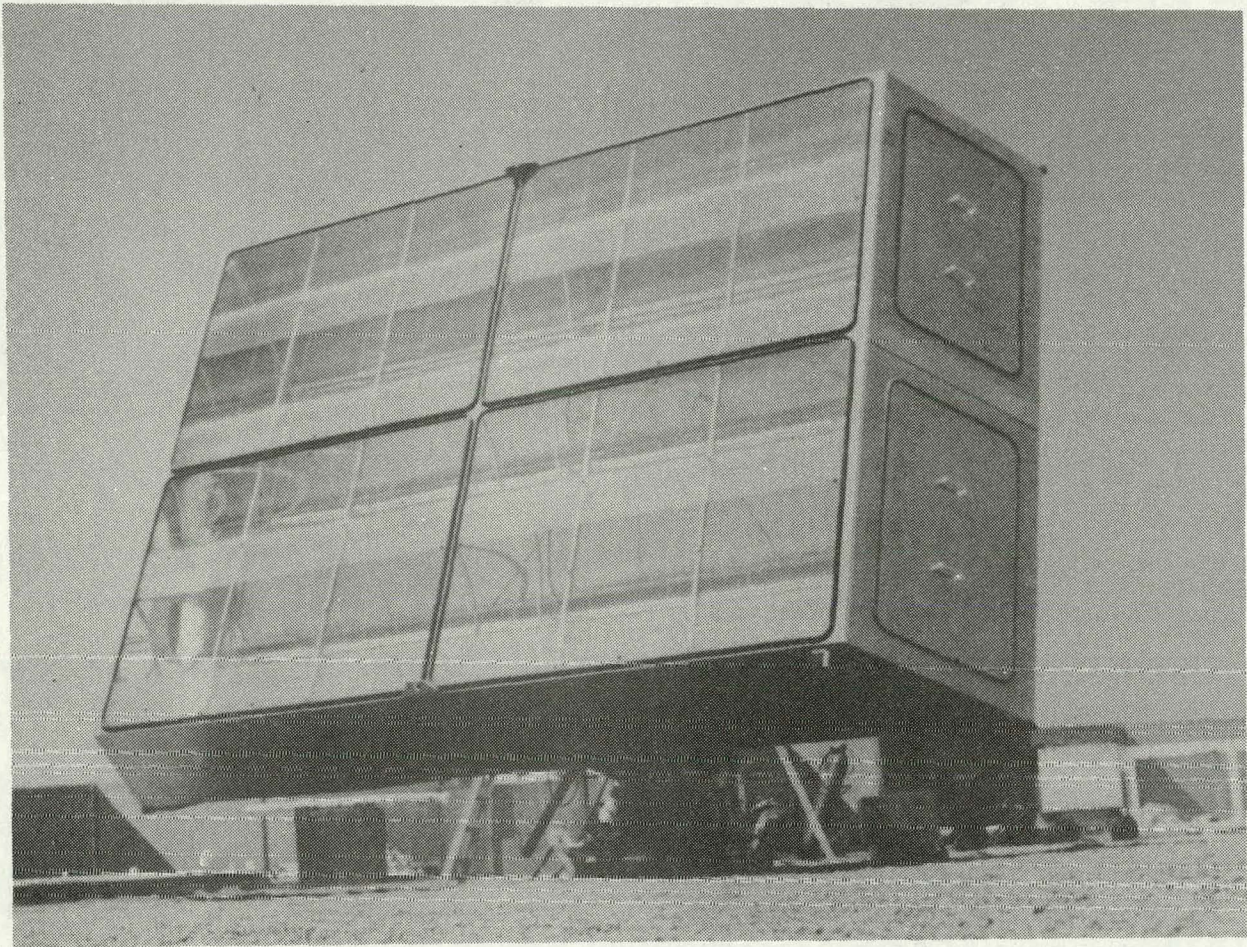

FIGURE 5. MDAC Linear Fresnel Lens Collector

tube is housed in a polished stainless-steel secondary concentrator. A flat glass cover is also supported by the secondary concentrator and minimizes convective losses. The collector tracks the sun in two axes. A single-post pylon mount similar to that designed by MDAC for their heliostat supports the collector. The cast acrylic lenses were developed and fabricated by Swedlow, Inc.

Scientific Atlanta has adopted a different manufacturing approach to the Fixed Mirror Solar Collector (Fig. 6). Whereas General Atomic bonds their mirror strips to concrete bases, the Scientific Atlanta collector structure is a stamped and riveted sheet metal assembly stiffened by braces. The mirror facets are silvered glass strips 7.6 cm wide and 75.6 cm long. These glass strips are attached to the structure by spring clips. The module tested at Sandia is 9.1 m long and has an aperture 2.1 m wide. The collector is oriented east-west. The receiver is of the line cavity type typical of low rim angle collectors. A flat bank of seven 1.0-cm-diameter black-chrome-coated tubes is installed in a sheet-metal housing. The receiver aperture is glazed with flat low-iron glass installed at the base of a conical secondary concentrator. The unilluminated side of the receiver is insulated to minimize thermal losses.

Solar Kinetics, Inc., has also developed a parabolic trough solar collector.⁴ The concentrator has a 1.3 m aperture, is 6.1 m in length, and has a 90° rim angle (Fig. 7). A two-row array of four such collectors oriented east-west formed the configuration tested at Sandia. The concentrator structure is formed of cast aluminum ribs to which aluminum sheet stack is riveted. The reflective surface is FEK-244 aluminized acrylic film, a later generation version of FEK-163 by 3M Company. The receiver tube is black-chrome coated steel tubing enclosed in a sealed borosilicate glass tube. The glass seal is formed by silicone O rings that make it easier to remove or replace the glass jacket. An evacuation port and valve were incorporated on each receiver so that vacuum effects tests could be conducted. For experimental purposes, a

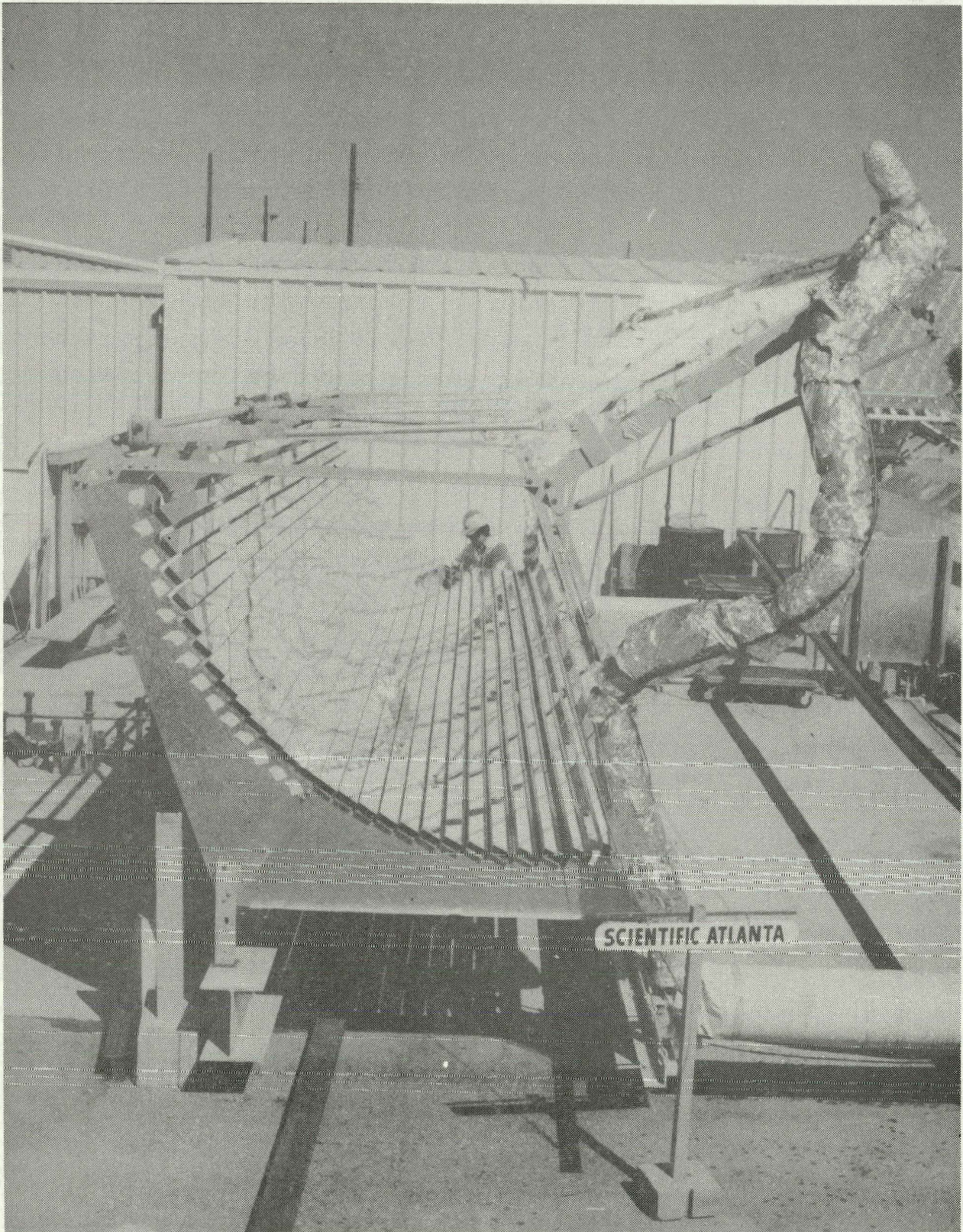

FIGURE 6. Scientific Atlanta Faceted Fixed Mirror Collector

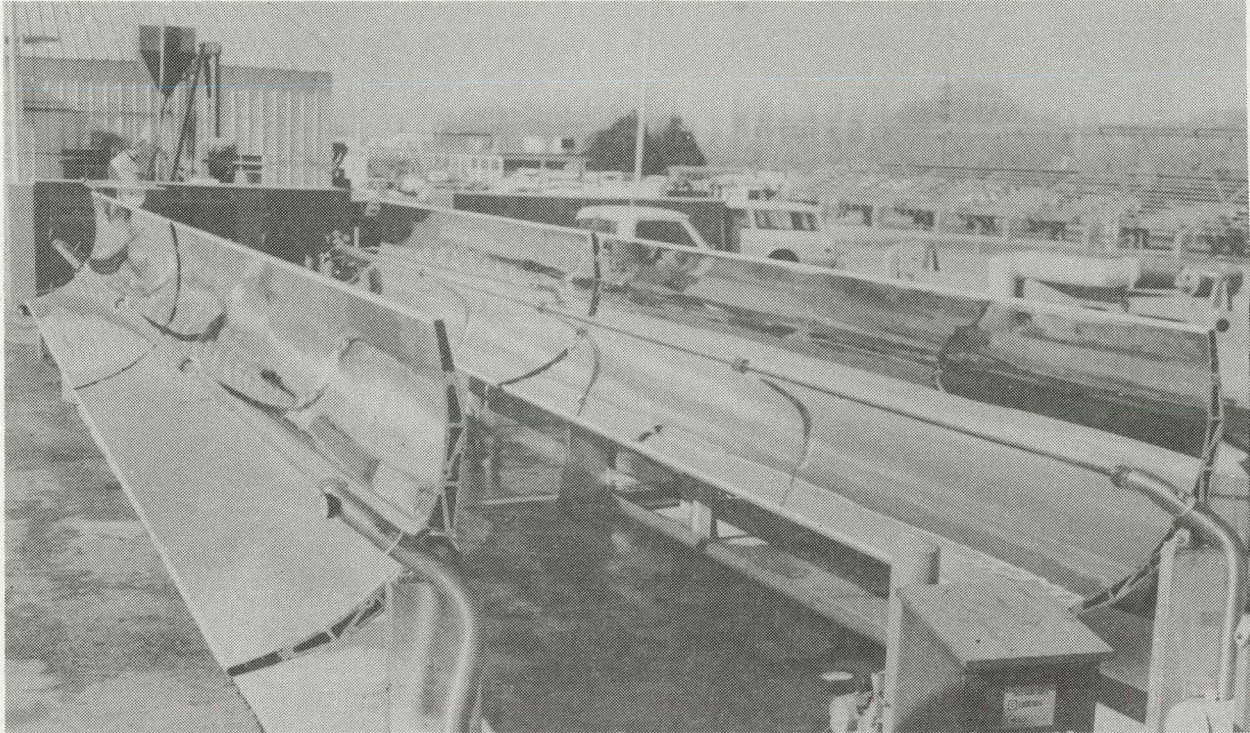

FIGURE 7. Solar Kinetics Parabolic Trough Collector

variety of receiver tube plugs were provided and evaluated. Whereas most collectors use electric motor drive systems, the Solar Kinetics unit employs a hydraulic system. One advantage of such a system is the rapid slew rates that are possible for emergency defocus in case of coolant loss or flow stoppage. Because of the relative ease of receiver tube assembly, one 12 m string of the Solar Kinetics collector will remain installed at the CMTF to act as a test bed collector in support of the black-chrome process development project being conducted within Advanced Technology Development.

The SLATS collector⁵ by Suntec Systems, Inc., features a Fresnel reflector consisting of movable longitudinal facets (slats) or curved silvered glass (Fig. 8). The module tested at the CMTF was 3.5 m wide by 12.5 m long and consisted of two bays of 10 such slats each 30 cm wide and 3. m long. The individual slats are each set at the proper angle at installation and are linked

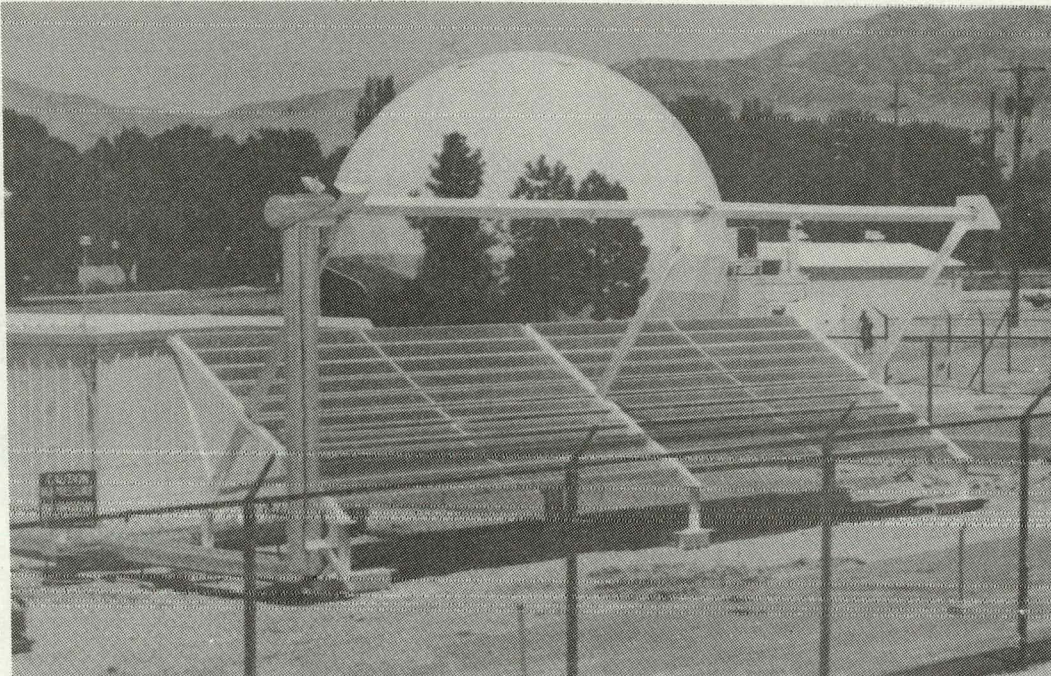

FIGURE 8. Suntec SLATS Collector

mechanically to a drive bar so that the sun's reflected image can be continuously focused on a fixed overhead receiver. The bank of slats are tilted southward at about the latitude angle although this tilt can be varied for application tailoring. The slats can be rotated downward when not in operation. This can be an important feature to prevent hail damage and reduce snow, frost, and dust effects. The line-cavity type receiver consists of two parallel steel pipes which are black-chrome-coated and are configured in a counterflow (down and back) arrangement. The tubes are housed in an insulated strongback structure and lie behind a 10-cm glass aperture.

A summary of collector characteristics is presented in Table 1.

CMTF Test Results

Comparative performance data for the above collectors⁶ are presented in Figs. 9 and 10. Figure 9 shows peak efficiency versus receiver outlet temperature. Figure 10 shows thermal loss for each receiver as a function of collector aperture. Receiver thermal

Table 1. Collector Characteristics

Collector	Aperture Area m ²	Secondary Aperture cm	Receiver Length m	Focal Length cm	Geometric Concentration Ratio	Reflector Surface
General Atomic	16.26	13.3	7.16	302.0	43:1	Silvered Glass
Hexcel	15.91	--	6.40	91.4	67:1	FEK-163 Acrylic
McDonnell Douglas	15.54	7.80	17.34	92.7	24:1	Cast Acrylic Fresnel Lens
Solar Kinetics	12.7	--	12.20	26.7	41:1	FEK-244 Acrylic
Scientific Atlanta	18.75	13.3	9.10	248.9	28:1	Silvered Glass
Suntec	35.97	--	12.20	305.0	35:1	Silvered Glass

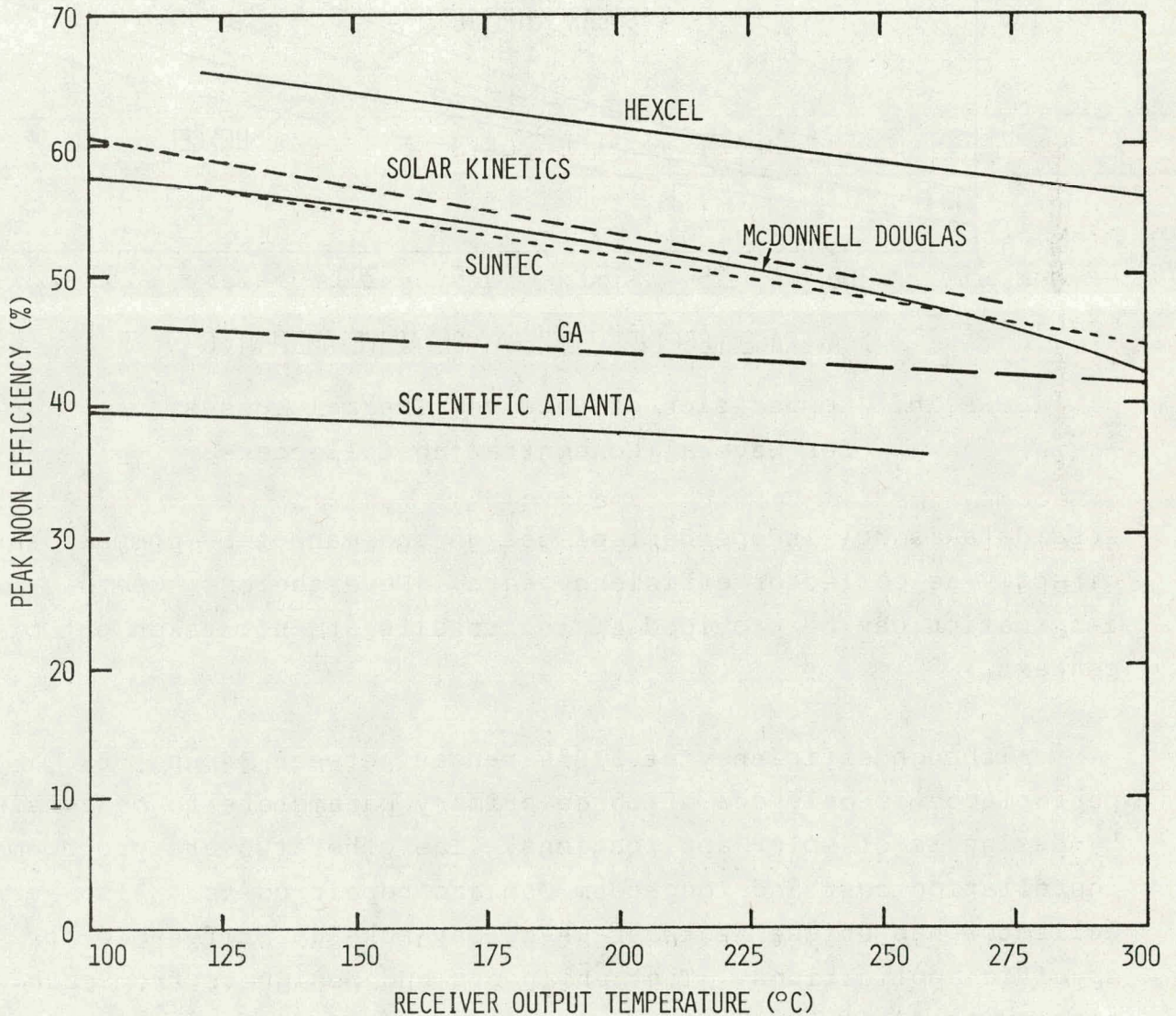

FIGURE 9. Comparison of Peak Efficiency vs. Temperature for Several Concentrating Collectors

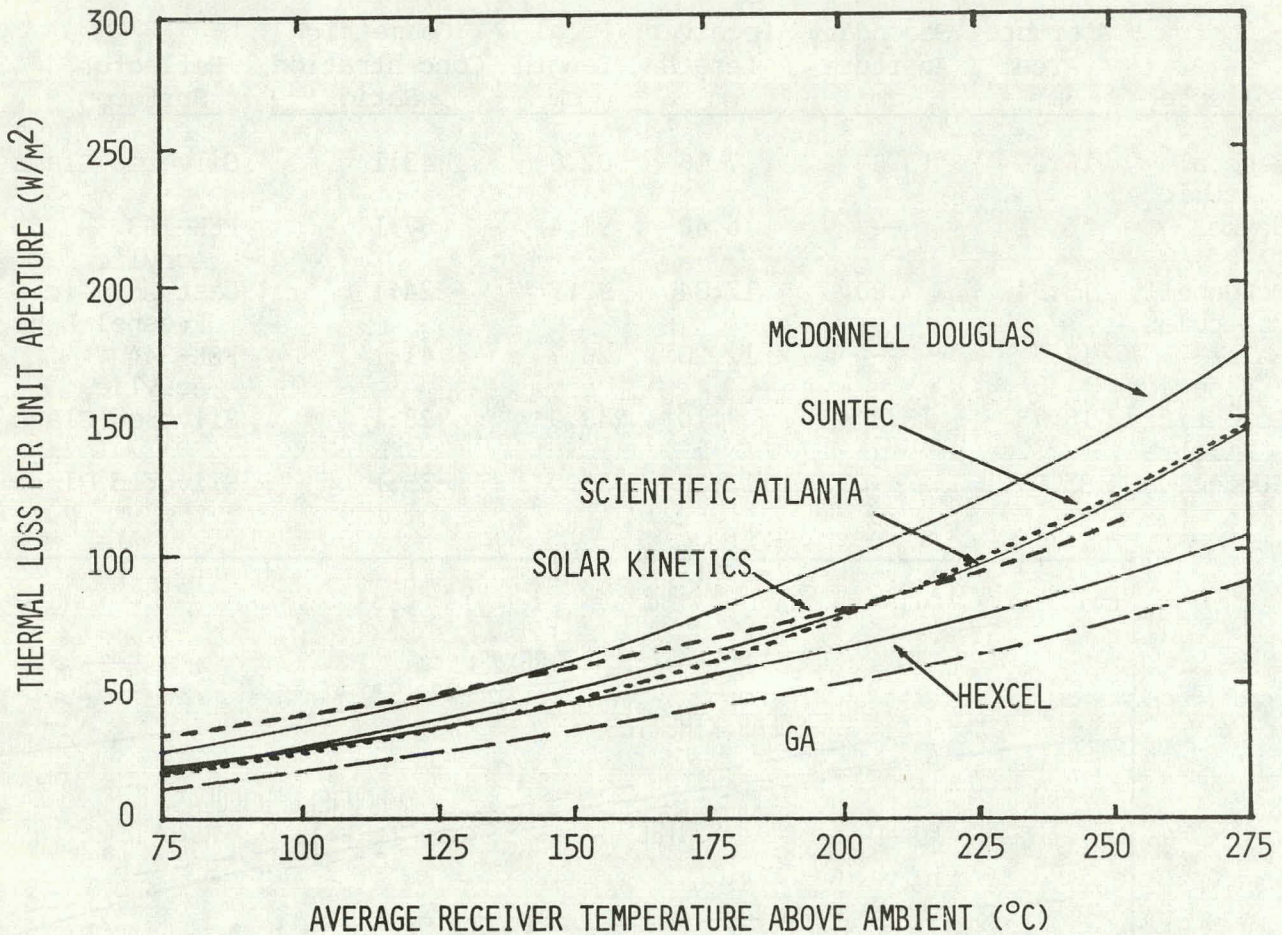

FIGURE 10. Comparison of Receiver Thermal Losses for Several Concentrating Collectors

loss data is not independent of design and cannot be compared as directly as collector efficiency data. Nevertheless, useful information can be provided if the results are not taken out of context.

Although efficiency at 310°C ranges between 34 and 56%, performance is only one of three primary parameters to be considered by designers of solar applications. The other two are procurement/installation cost and long-term O&M and repair costs. Also every collector has unique features which may make it preferable for specific applications. Test engineers and designers from each company participated in their test series and without exception each identified areas for design improvements and cost reductions.

STF Collectors

At the System Test Facility, an array of parabolic trough collectors, designed and installed by Sandia, has been in operation since December 1975. Figure 11 is a view of two of the strings of parabolic trough collectors at the STF. The concentrator is a 2.7 x 3.7 m marine plywood structure with a reflective surface consisting of aluminized Teflon bonded to aluminum sheet. Five modules are ganged to form an 18 m string through which the heat-transfer fluid, Therminol-66, flows in series and which operates with a single tracking and drive system. The receiver tubes, carbon steel pipe with black chrome selective coating, are jacketed in an evacuated glass envelope. The 200 m² collector field is arranged in east-west horizontal strings. The output temperature is 310°C.

Considerable data have been accumulated for this system, both in performance testing and in O&M experience.^{7,8,9} Early performance measurements of the collector field indicated peak noon-time efficiencies of slightly more than 50% at 310°C (Fig. 12).

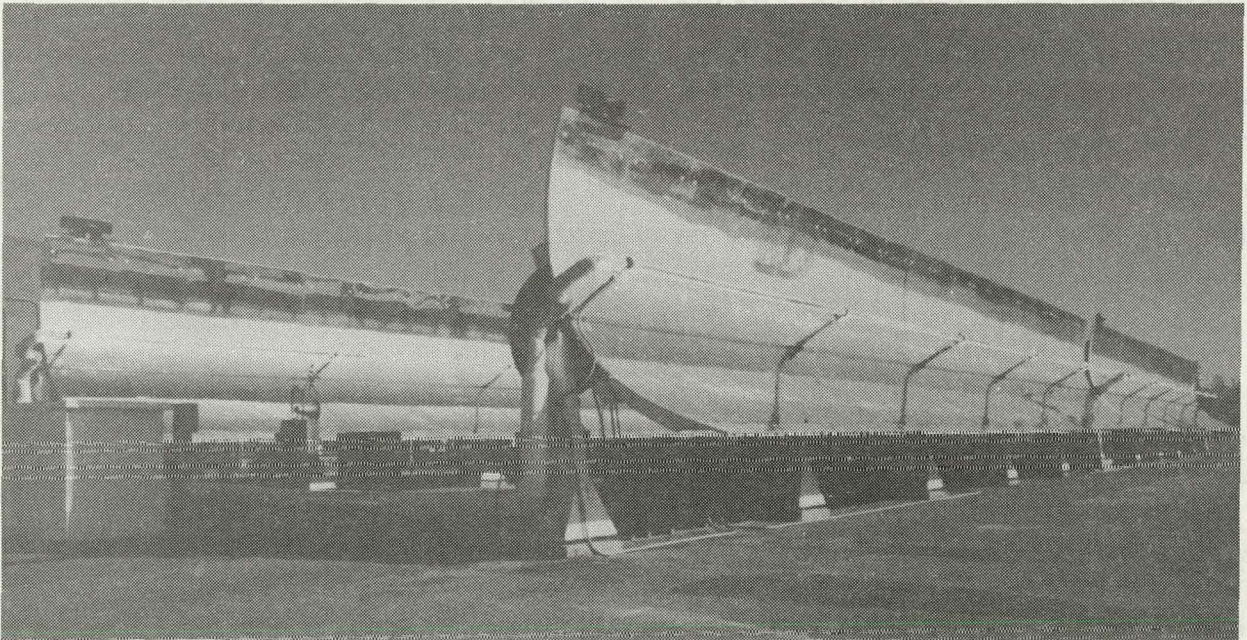

FIGURE 11. Sandia Parabolic Trough Collector Field

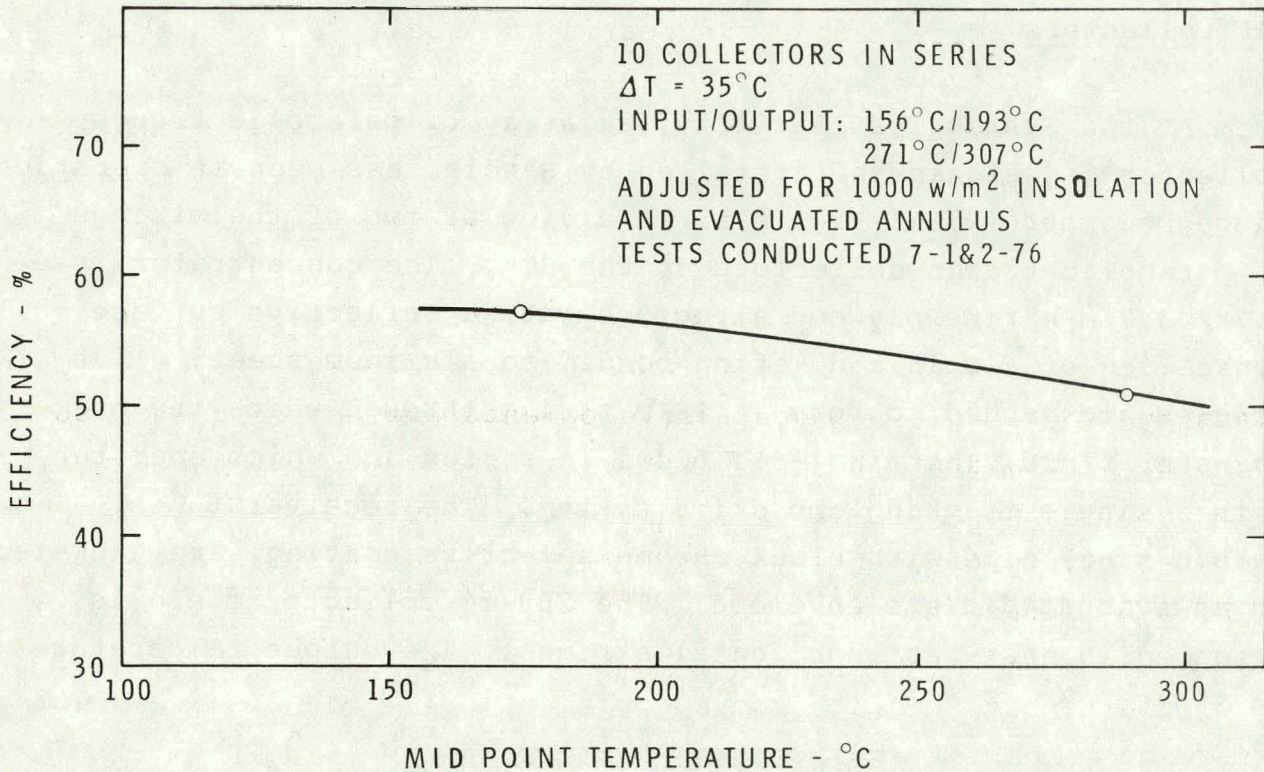

FIGURE 12. Peak Efficiency vs. Temperature for Sandia Parabolic Trough Collector Field

Since its initial operation the collector field has accumulated more than 2000 hours of operation at high temperature. Peak efficiency over this time has degraded to slightly under 40% at 310°C . The major causes of this degradation are loss of specular reflectance in the mirror surfaces, loss of absorptance in the black chrome selective surface on the receiver tubes, and moderate warping of the concentrator structure, which has resulted in increasing surface slope errors.

The aluminized Teflon mirror surface is difficult to maintain in near-new condition. Cleaning is a problem because the softness of the Teflon surface precludes mechanical cleaning techniques. Also, the film is easily damaged and any unrepaired surface break develops rapid environmental degradation. Aluminized acrylic films are somewhat more durable. Sandia, Honeywell Corporation, MDAC, and others are conducting outdoor aging tests to determine long-term degradation of a variety of reflective materials.

The black chrome selective coating degrades at temperatures near 300°C. Absorptance losses of 10-12% within a few hundred hours of high-temperature operation have been observed in the Sandia collectors as well as those of several other firms.^{10,6} Absorptance does seem to stabilize after the initial period of degradation.

Both problems are being addressed within the materials and processes task of Application Technology Development Project. Thin glass and sagged glass process developments are being pursued so that silvered glass can economically be applied to parabolic surfaces. Black chrome process control studies are being conducted to determine the sensitivity of electroplating process parameters relative to high-temperature stability.

Other insights gained as a result of collector field operating experience are as follows:

Early morning startup--Getting a solar plant to steady-state design-temperature operation rapidly each day is vital. For a given daily demand, the collector field size is inversely proportional to the number of hours it can be operated at rated output. Factors which delay start-up are the heat capacity of the pipelines, insulation, and receiver tube walls. Adding to the difficulty is the viscosity of most heat-transfer oils (Therminol-66, for instance) when cold.

Tracking and Drive--Computerized tracking may be superior to systems based on sun sensing. A third method, which involves sensing the energy distribution at the receiver and sending error signals to maximize the flux incident on the receiver, shows promise. Drive train design and motor selection are areas in which a wide variety of designs (often bad) are seen. Care must be exercised in design to achieve simple, low-cost mechanical designs and to devise control strategies and select drive motors which minimize parasitic power demands.

Additional Collectors Under Development

The AAI Corporation, of Baltimore, Maryland, has developed a fixed mirror, movable receiver concentrating collector for which they visualize rooftop or other space limited applications. The collector, called the Modular Solar Roof because it is intended to serve as the roof of a building, features a foam aluminum concentrator structure of parabolic cross section. The concentrator structure is faced with aluminum sheet and 5-cm silvered glass strips are bonded to it. The movable overhead receiver has two 2-cm copper tubes with mechanically selective absorbing surfaces. The tubes are installed in an insulated channel structure with a tempered glass aperture. An array of 16 such modules each 2.4 x 9.7 m are presently in operation on the roof of an office building in Disneyworld where they are primarily used to drive an absorption chiller plus a modest winter heating load.

AAI has also developed a linear concentrator of the movable-mirror, fixed-receiver type. The basic module is 2.7 x 10.7 m and contains 32 silvered glass slats, each are 30 x 244 cm. The overhead receiver consists of a black-chrome-coated pipe installed in an insulated channel. A cover glass and a secondary concentrator can be applied or left off depending on the temperature requirements of the application. The bank of mirrors can be tilted to the south or left flat depending on the application. A field of such collectors has been installed at a concrete block plant in Harrisburg, Pennsylvania, under a DOE solar process heat contract. Also, this collector is being modified for use as a water-cooled photovoltaic concentrator. An array of these collectors will be installed at a hospital in Puerto Rico under a recently awarded DOE contract.

Acurex-Aerotherm has also developed a parabolic trough solar collector. A field of these collectors was installed in 1977 at the DOE/New Mexico Solar Irrigation Experiment in Willard, New Mexico (Fig. 13). Acurex is also the prime contractor for the Deep-Well Irrigation Experiment at Coolidge, Arizona, which will be operational

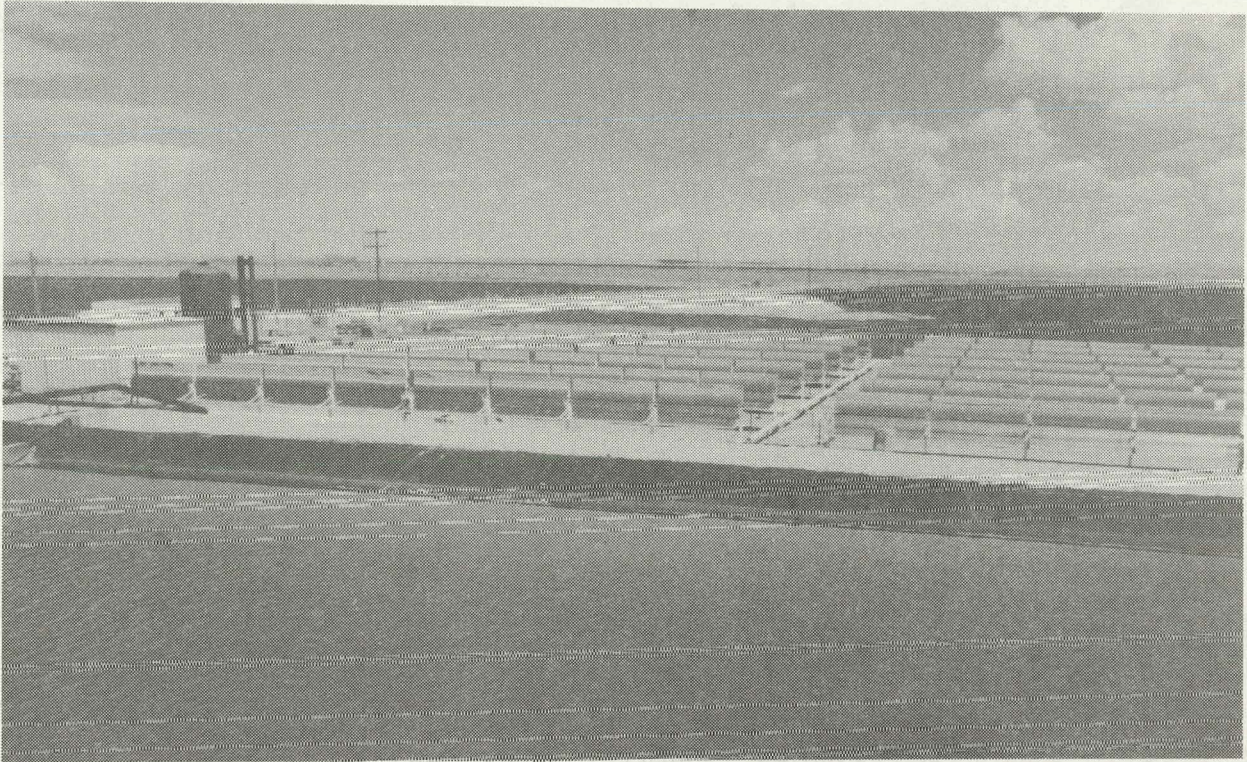

FIGURE 13. Shallow Well Solar Irrigation Experiment at Willard, New Mexico--Acurex Collectors

in 1979. In addition, Acurex has recently completed a solar process heat installation at a Campbell's Soup plant in Sacramento, California, and will soon be starting a 500-kW distributed collector solar power plant in Spain for the IEA. For the Willard irrigation experiment, the collector field is 625 m² and consists of 112 collector modules operating as 14 strings of 8 modules each. The 90° rim angle modules are 1.85 x 3 m in aperture, use Alzak structurally and as the reflective surface, and have a black-chrome-coated, glass-jacketed, non evacuated receiver assembly. The field is arranged in horizontal, north-south rows. The collector field outlet temperature is 215°C. An advanced, higher temperature version of this collector is being designed for the deep-well experiment. A prototype of this collector will be tested at the CMTF in the autumn of 1978.

Del-Jacobs has developed, under contract to Sandia, a small parabolic trough collector featuring sagged silvered glass supported by a structure of stringers and sheet-metal ribs. The concentrator module is 60 cm wide by 240 cm long. The non evacuated, but sealed and desiccated, receiver tube is black-chrome-coated and glass-jacketed. This collector is designed for high-pressure water at 310°C. An array of eight such collectors in two parallel rows (11.5 m²) will be tested at the CMTF during the summer of 1978.

FMC Corporation has also developed, under contract to Sandia, a novel collector which features a movable stainless-steel belt containing a faceted silvered-glass Fresnel mirror embedded in a pliable adhesive. This concept utilizes handling equipment technology in which FMC has expertise. The concentrator has two degrees of freedom, one being a southward tilt of the entire collector and the other an azimuth track achieved by moving the Fresnel belt along a set of rollers and tracks. A fixed overhead receiver tube absorbs the concentrated solar radiation from the mirror. A small model of this system has been delivered to Sandia and will be tested at the CMTF during the summer of 1978.

Honeywell, Inc., has long been active in solar energy development. Their work has touched on nearly all aspects of material development and collector design--flat plates, troughs, dish collectors and central receivers. One of their early designs, a 120° rim angle parabolic trough, was first placed on test at Desert Sunshine Exposure Test in 1974. The receiver has a selective coating and a glass jacket. A more recent design¹¹ features a concentrator consisting of one-half of a parabola constructed of aluminum honeycomb. The reflective surface is aluminized acrylic film. The selectively coated receiver tube is mounted in an insulated metal housing with a glass window at the receiver aperture. The basic module has an aperture 1.3 m wide by 6 m long. A 1900 m² array of these collectors is being installed on the roof of Honeywell's World Headquarters Building in Minneapolis, Minnesota. They will serve the heating and cooling loads of the building.

The Polisolar Company of Switzerland has sold Sandia north-south tilted parabolic trough collectors for evaluation at the CMTF late in 1978. The 21.9-m² system to be tested consists of a bank of 12 collectors, each 0.57 m x 3.2 m. The parabolic troughs are of sheet-metal construction and have a rim angle of 120°. They are installed in a support frame in groups of six modules with common tracking and drive hardware. The reflective surface is saggd silvered glass. The parabolic troughs rotate about a stationary receiver tube. The receiver tube is glass jacketed but non evacuated. A selective absorptive coating is applied. Fluid flow through the system is in series--single pass through each collector.

Collector Costs

Precise costs, particularly projected cost estimates based on assumptions of mass production and the accumulation of production experience, are difficult to address.

The near-term, mid-1980 goals in the national program for solar total energy and small power systems are \$1000/kW (e+th) and \$1500/kWe (1976 dollars), respectively, per installed kilowatt of peak power. Solar installations at that cost should be reasonably competitive; and with moderate federal incentives, the commercialization of these solar energy applications can become reality. These goals imply a collector cost of about \$75/m².

Currently, several companies are offering fixed-price quotations of \$160 to \$230/m² not including installation for line focusing collectors in the 300°C performance range.

A recent study¹² on collector evaluation techniques developed a quantifiable feature list and a figure of merit. Contacts with more than 30 companies were made and about 20 responses tabulated. The elements of the figure of merit include annual performance and installed cost. A very interesting unit called a materials figure of merit was also developed. The materials figure of merit is based

on performance and materials cost only. This is a most significant unit because it sets a lower bound on mass-produced costs and properly suggests the powerful influence of lightweight low-cost materials on production costs. Recall the well-known (and possibly overused) rule of thumb that mass produced machinery such as cars and major appliances cost \$1.50 per pound. This study resulted in projections of total costs which ranged between \$150 and \$220/m² including installation, foundations, and interconnecting pipelines. The materials cost projections ranged between \$38 and \$70/m².

Applications

An aggressive, application-oriented strategy is being implemented within the Dispersed Power Systems Program to push solar technology, gain public acceptance, and displace significant quantities of conventional energy as rapidly as possible. In each subprogram a series of DOE-funded system experiments is under way. These will serve to build private-sector expertise, identify technical and institutional problems, and accumulate long-term performance data and O&M experience.

Two Solar Total Energy Large Scale Experiments are in preliminary design. The first LSE is to provide electrical power and thermal energy to a troop housing complex at Ft. Hood, Texas. Westinghouse Electric Corporation has selected a field of line-focusing parabolic trough collectors which will operate at an outlet temperature of 260°C to drive a steam turbine. The second LSE is for a knitwear factory in Shenandoah, Georgia. General Electric has selected a distributed field of two-axis tracking, point-focusing parabolic dish collectors which will elevate the temperature of a heat-transfer fluid to 300°C or 400°C to drive a steam turbine. Strong consideration is being given to constructing in the near future an LSE which features a small central receiver.

The two solar irrigation projects in Willard, New Mexico, and Coolidge, Arizona, have been discussed previously. The shallow-well

experiment at Willard is being expanded in 1978 to include a quarter-section center pivot sprinkler system and a new collector field of about 650 m². The contract for this new field has been awarded to Solar Kinetics who will install an advanced version of the parabolic trough collector described above and tested at the CMTF.

The first Small Power System Experiment is under way. Three system design contracts have been awarded by JPL and site selection is scheduled for late 1978. This project will be for electrical power only and will produce about 1 MW peak. The initial experiment will employ a point focusing collector system--either parabolic dish or central receiver.

A very active photovoltaic concentrator development project is also under way within DOE. The output of photovoltaic cells is approximately proportional to the incident energy density. Therefore, the use of concentrating solar collectors with arrays of solar cells offers the attractive possibility of providing cost-effective solar power plants before solar cell production costs are reduced to competitive levels. The cells must be maintained at relatively low temperatures, which suggests a total energy system possibility in which the coolant for the solar cells could be applied to a nearly thermal load.

A hybrid photovoltaic/thermal experiment to further develop this concept is being constructed at the Mississippi County Community College in Blytheville, Arkansas. The solar concentrators for this application will consist of flat, line-focusing Fresnel reflectors by Honeywell, Inc. The receiver will be lined with solar cells which will be dynamically cooled by water flowing through the receiver tube. The electricity will be used directly or stored in batteries. The hot water will be applied to heating and domestic hot water needs.

A series of industrial process heat experiments, some of which employ concentrating collectors, are being funded by the Conservation

and Solar Applications Division of DOE. The application projects to date serve thermal demands in the 200°C range and below, but the tremendous energy displacement and cost-effectiveness potential for this market is beginning to be appreciated. New initiatives involving larger installations and higher temperatures are being planned.

Some of the existing process heat experiments are listed in Table 2.

Conclusions

A rapidly building data base is becoming available to the designers of solar thermal application projects in the midtemperature range. Solid performance data is available or can be reasonably well predicted for a variety of well-designed and-constructed collectors. Cost projections are becoming more credible although needed high-volume production experience will be forthcoming only as government and privately funded application projects proliferate. Long-term O&M cost experience is crucial. Accumulating this experience cannot be accelerated, but the MSSTF and the wide range of "real world" system experiments involving different hardware concepts, applications, and geographies will help assure adequate breadth of experience. Problems encountered at the MSSTF and other operating application projects are being addressed by Advanced Technology Development and by the other R&D projects within the Solar Thermal programs.

As operating experience grows over the next several years, it will be interesting to observe the place taken in the spectrum of solar applications by each of the basic collector technologies-- flat plates, linear concentrating, point concentrating, and central receiver.

TABLE 2

PROCESS HEAT APPLICATION PROJECTS

<u>Contractor</u>	<u>Site</u>	<u>Product</u>	<u>Solar Collector</u>	<u>Operating Temp °C</u>	<u>Solar Use</u>
Honeywell, Inc.	Fairfax, AL	Textile Fabric	1/2 Parabolic Trough Hexcel Concentrator	175	Steam for Cylindrical Drying Rollers
Midwest Research Institute	Lawrence, KA	Alfalfa	Staged-Flat Plates Plus Hexcel Parabolic Troughs	250	Preheat Combustion Air
Acurex Corp.	Sacramento, CA	Soup Can Washing Line	Staged-Flat Plates Plus Acurex Parabolic Troughs	90	Hot Wash Water
AAI Corp.	Harrisburg, PA	Concrete Block Curing	AAI Linear Facet Concentrator/ Fixed Receiver	90	Hot Curing Water

References

1. V. E. Dudley and R. M. Workhoven, "Performance Testing of the General Atomic Fixed Mirror Solar Concentrator," Sandia Laboratories Report SAND78-0624, May 1978.
2. V. E. Dudley and R. M. Workhoven, "Performance Testing of the Hexcel Parabolic Trough Solar Collector," Sandia Laboratories Report SAND780381, March 1978.
3. V. E. Dudley and R. M. Workhoven, "Performance Testing of the McDonnell Douglas Fresnel Lens Rotating Array Solar Collector," Sandia Laboratories Report SAND780625 (to be published).
4. V. E. Dudley and R. M. Workhoven, "Performance Testing of the Solar Kinetics Parabolic Trough Solar Collector," Sandia Laboratories Report SAND78-0626 (to be published).
5. Sandia Laboratories, "Performance Testing of the Suntec SLATS Solar Collector," SAND78-9623, (to be published).
6. V. E. Dudley and R. M. Workhoven, "Summary Report: Concentrating Solar Collector Test Results, Collector Module Test Facility," Sandia Laboratories Report SAND78-0815, May 1978.
7. T. D. Harrison "Solar Total Energy Systems Test Facility Project Semiannual Report, April 1976-September 1976, SAND76-0662, April 1977.
8. B. J. Petterson, "Solar Total Energy Test Facility Project Semiannual Report, October 1976-March 1977," SAND77-0738, August 1977.
9. H. J. Gerwin, G. S. Kinoshita, "Solar Total Energy Project Semiannual Report, April - September 1977," SAND78-0109, April 1978.
10. R. R. Sowell, and R. B. Pettit, "Thermal Aging of Electro-deposited Black Chrome," SAND78-0554, April 1978.
11. B. P. Gupta, Honeywell, Inc., "Development and Evaluation of a Medium Temperature Concentrating Collector," presented at ERDA Concentrating Solar Collector Conference, Georgia Institute of Technology, Atlanta, Georgia, September 26-28, 1978.
12. L. E. Torkelson, A. Potter, "Solar Collector Evaluation Studies," presented by L. E. Torkelson at the Advanced Solar Thermal Technology Semiannual Review, SERI, Golden, Colorado, May 9, 1978.

THE PARABOLIC CONCENTRATING COLLECTOR

A Tutorial by Vincent C. Truscello

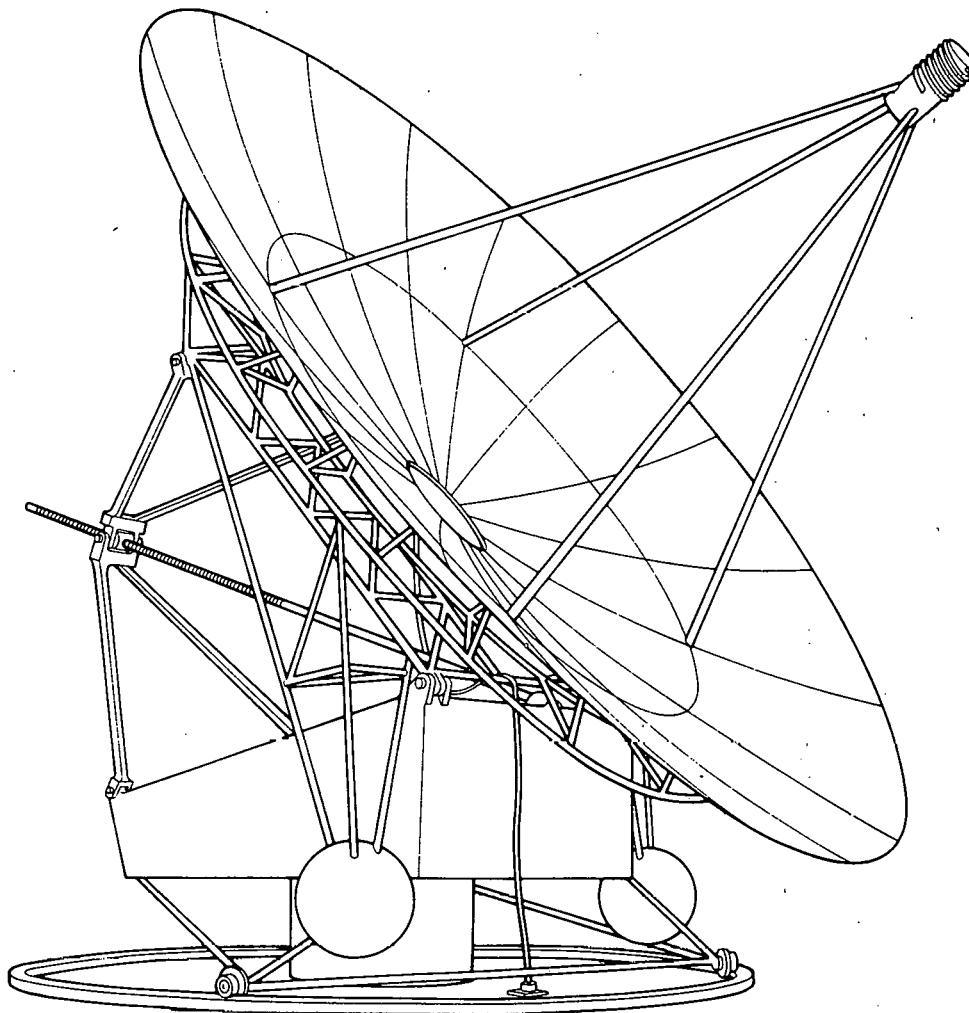

Jet Propulsion Laboratory / California Institute of Technology

THIS PAGE INTENTIONALLY LEFT BLANK

I. Introduction

The point-focusing parabolic concentrator is considered by many as the ultimate form of solar energy collector. It has such attractive features as modularity and high collection efficiency and can provide high-quality thermal energy for conversion into electricity by a variety of large and small heat engines operating over a wide range of temperatures. If desired, temperatures of 2000-3000°F are easily achieved, although most electric systems optimize at temperatures in the 1500-2000°F range. Because of their high temperature potential, it is possible to additionally use these devices as a source of heat for a variety of process heat and fuel and chemical applications.

An early version of a point-focusing parabolic collector was actually built in 1901 and was used for irrigation during the early years in California. However, the availability of cheap fuels curtailed subsequent utilization.

The purpose of this paper is to present a tutorial overview of point-focusing parabolic collectors. In the first section, the optical and thermal characteristics of such collectors are discussed in some detail. Data representing typical achievable collector efficiencies are presented, and the importance of balancing collector cost with concentrator quality is argued through the development of a figure of merit for the collector. The impact of receiver temperature on performance is assessed and the general observation made that temperatures much in excess of 1500-2000°F can actually result in decreased performance. In the second section, various types of two-axis tracking collectors are described, including the standard parabolic deep dish, Cassegrainian and Fresnel, as well as two forms of fixed mirror collectors with articulating receivers. In the third section, the present DOE program to develop these devices is briefly discussed. Finally, the last section discusses present and projected costs of these collectors. Pricing information is presented for the only known (to the author) commercial design available on the open market.

THIS PAGE INTENTIONALLY LEFT BLANK

II. Analytical Considerations

A. Concentrator Optics

In its simplest form, the point-focusing parabolic concentrating collector intercepts solar energy and redirects it to a relatively small focal area as shown in Figure 1. With perfect optics and a point source of light, the focal area would, in fact, be a single point. The sun, however, has a finite diameter and, on a yearly average, subtends a half angle of about 4.6 milliradians (mrad), producing a somewhat enlarged focal point or image. Since a perfect parabolic concentrating surface does not exist, the image will be further enlarged due to misdirection of the light rays by misaligned surface elements caused by macroscopic surface waviness. The mirror quality (perfection of optics) can be statistically specified by both the circumferential and radial standard deviation of the surface normal. A surface error of $\sigma_s = 5$ mrad implies one standard deviation. Because of imperfect optics and the finiteness of the sun, additional enlargement of the sun's image occurs due to the relative location of the focal plane from the apex of the parabolic concentrator. This geometric effect is usually expressed in terms of the f/D ratio (i.e., the ratio of the focal length, f , and the diameter of the concentrator's aperture, D), or in terms of the rim angle (see Figure 1). The image becomes larger at large values of f/D (small rim angles) or at very small values of f/D (large rim angles). The optimum location, producing the smallest image size, occurs at an f/D value of about 0.6 (rim angles of about 45°) (Ref. 1). This optimum is not very sharp, and considerable departure from this value produces little enlargement of the solar image.

Another factor which is important in concentrator optics is the reflectivity of the surface. Not all of the energy that strikes the surface is reflected; some is absorbed. The fraction not absorbed is termed the total hemispherical reflectance. Unfortunately, not all of the energy reflected emerges at an angle demanded by perfect optics but, in fact, can

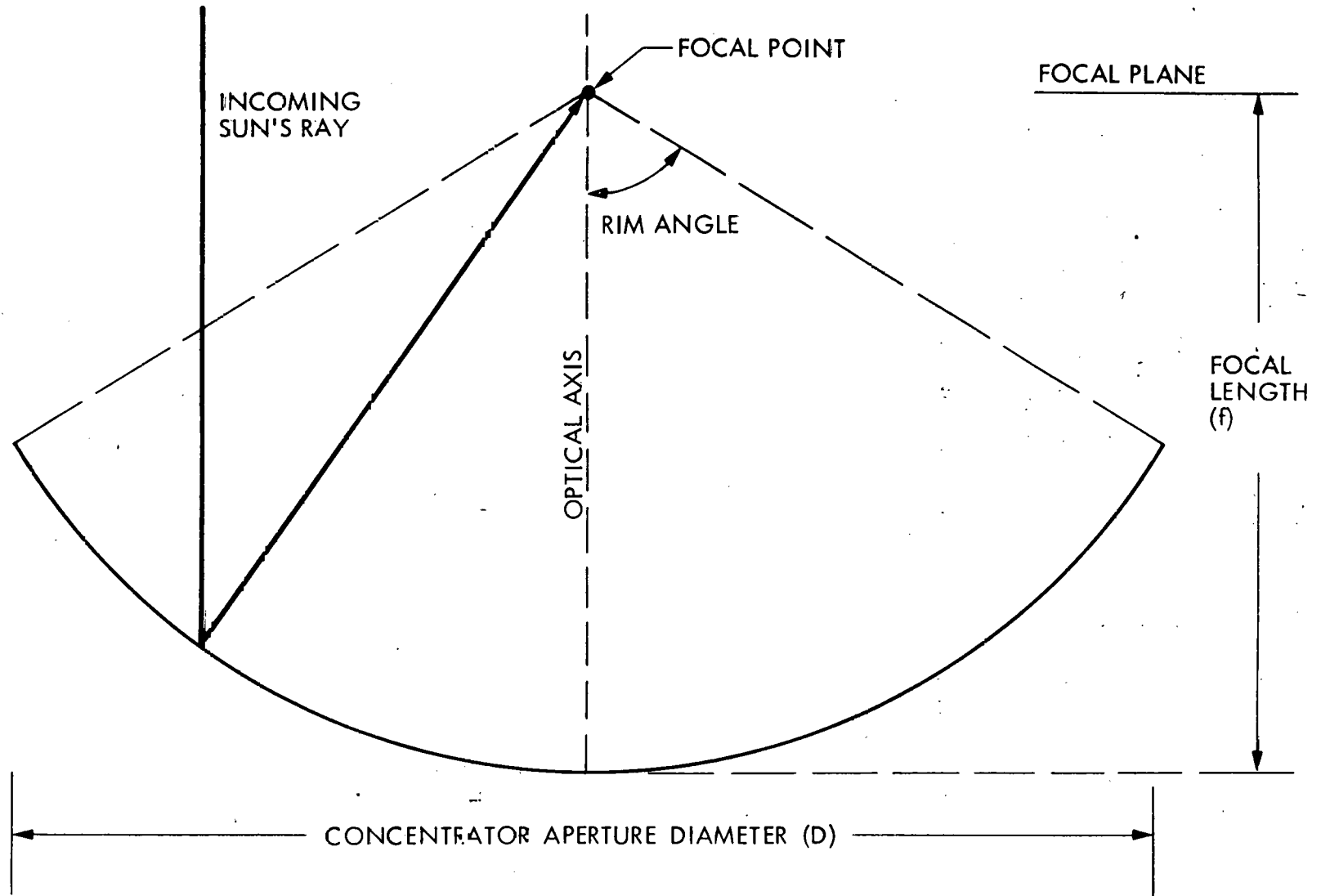
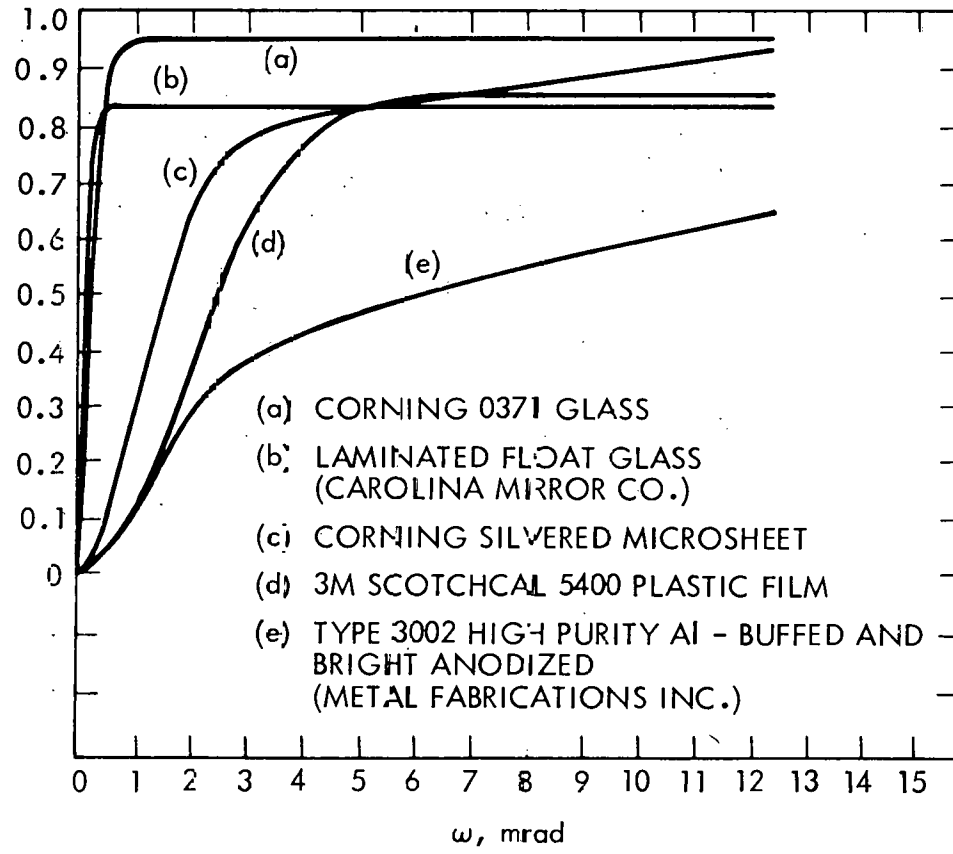
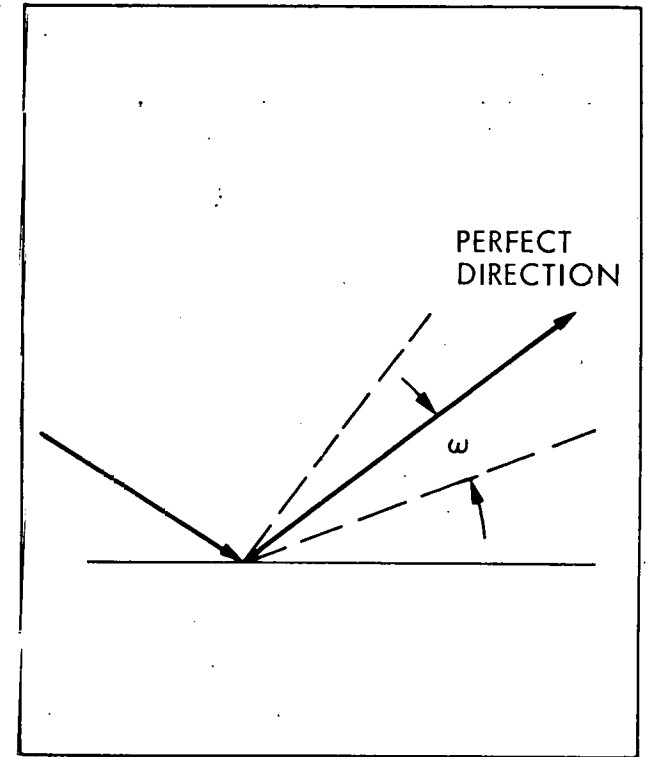

Figure 1. Concentrator Optics

be scattered at an angle considerably different than the perfect direction. This effect also adds to the enlargement of the image at the focal plane. A measure of this effect is shown for a number of different materials in Figure 2(a) taken from Reference 1. The curves indicate a rapid increase of reflectance to the asymptotic value (hemispherical reflectance) with increased spreading angle (ω). The spreading angle is defined as the deviation from the perfect direction (Figure 2(b)). Some materials, such as plastic films, reflect most of the energy within a rather large spreading angle (7-15 mrad) while materials like glass have very little spreading of the beam (i.e., less than 1 mrad). Clearly, the less the spreading, the smaller will be the solar image.

REFLECTED ENERGY CONTAINED IN OPTICAL CONE
ENERGY INCIDENCE

2(a)



2(b)

Figure 2. Reflectivity

B. Collector Efficiency

The importance of the size of the image produced by the reflecting parabolic surface is appreciated when one attempts to determine the collector efficiency defined as the ratio of energy absorbed by the receiver to the energy impinging the concentrator surface (see Figure 3). The efficiency can be defined by the relationship:

$$\eta_c = \frac{\text{energy absorbed by receiver}}{\text{energy impinging concentrator}} = \frac{\rho I_o A_c \phi \alpha_{\text{eff}} - Q_L}{I_o A_c}$$

where

ρ = total hemispherical reflectivity of concentrator surface

ϕ = the interception factor defined as the fraction of the energy reaching the focal plane which enters the receiver aperture

α_{eff} = the effective solar absorptance

Q_L = the thermal losses from the receiver (primarily due to reradiation from the receiver aperture)

I_o = the solar insolation

A_c = the concentrator aperture area

To maximize η_c for a given insolation and concentrator size one can decrease the value of Q_L which is dominated by the reradiation of energy from the receiver aperture. This can be accomplished by decreasing the receiver aperture area. However, decreasing this area impacts the amount of energy which can enter the receiver because of the finiteness of the sun's image produced by the concentrator. Clearly, one wants to make this image size as small as possible to get as much of the image into the receiver aperture. It has been found that for most cases the optimum aperture size is not that which allows all of the energy to enter; rather, an intercept factor of 95-98% (i.e., a 2-5% spillover) is optimum. Typical intercept factors versus receiver aperture radius is shown in Figure 4 (from Ref. 2) for two

$$\eta_c = \frac{\rho I_o A_c \phi \alpha_{eff} - Q_L}{I_o A_c}$$

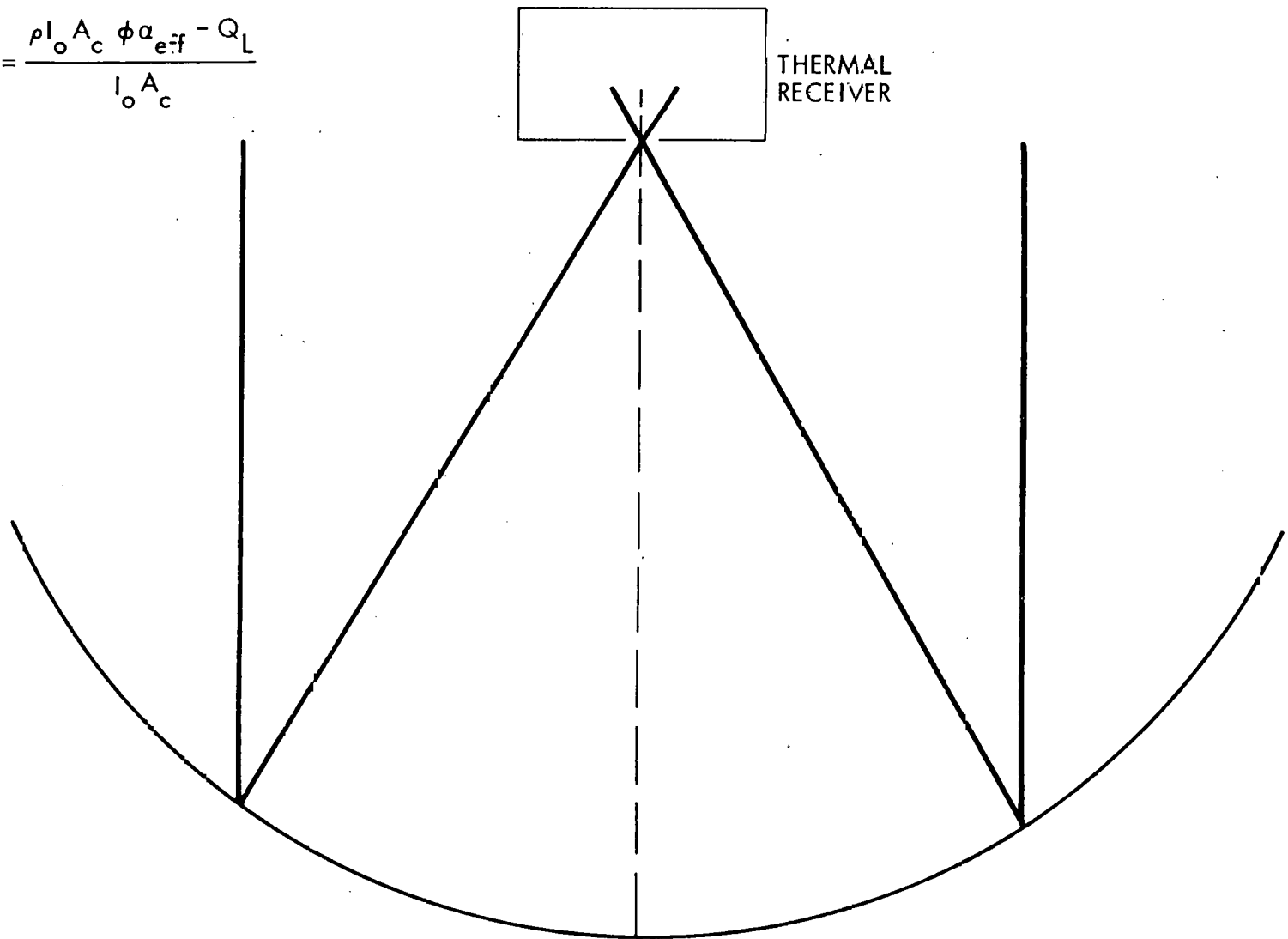

Figure 3. Collector Configuration

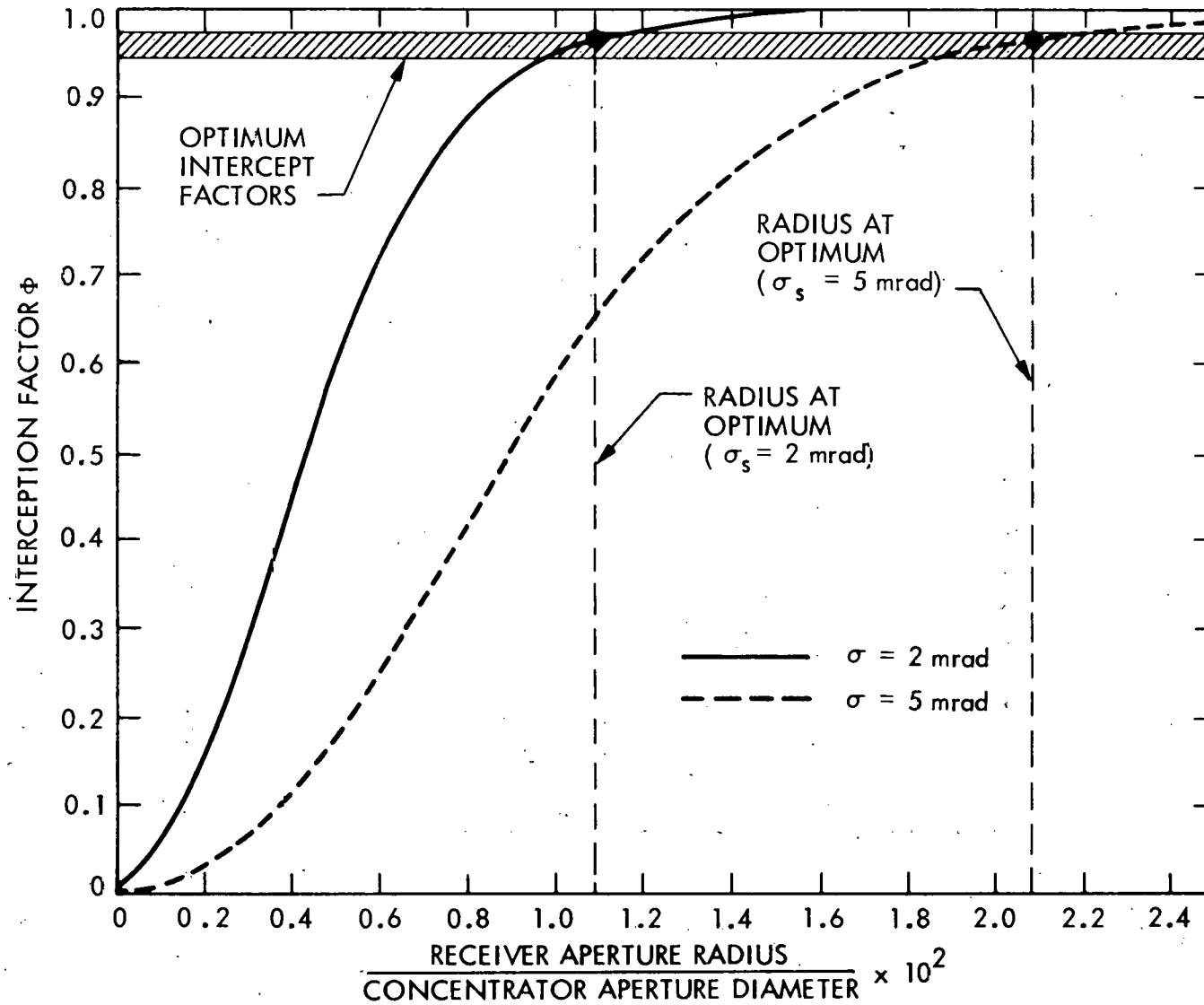

Figure 4. Interception Factor vs Receiver Aperture Radius

different values of concentrator quality. As is clearly shown, the larger the surface errors (i.e., $\sigma_s = 5$ mrad), the larger must be the radius of the receiver aperture to achieve the optimum beam intercept. Note also that most of the energy is found within the middle portion of the beam and little is at the edge. This is why the optimum aperture radius does not correspond to full acceptance of the beam (intercept factor of one).

Values of collector efficiency have been calculated for a concentrator/receiver combination having an f/D of 0.6 under an irradiation of 0.8 kW/m^2 . Figure 5 shows collector efficiency versus concentrator quality expressed in mrad. Data adapted from Reference 2 are presented for four values of receiver temperature and two values of emissivity. The receiver absorption area to aperture area (A_w/A_o) was taken as 5. The concentrator was assumed to have a reflectivity versus spreading angle given by the curve corresponding to Corning 0317 glass shown in Figure 2(a), except that the hemispherical reflectivity was taken as 0.85 to account for potential degradation. At a receiver temperature of about 300°C the collector efficiency varies only from 75% to 83% over the range of 1 to 8 mrad in concentrator quality. At 900°C the collector efficiency is much more sensitive to concentrator quality and requires surface accuracies of 2 to 3 mrad to obtain reasonable efficiencies. Note the importance of surface emissivity (or absorptivity) as receiver temperature is increased. At low temperatures it is not much of a factor, but at receiver temperatures of 1300°C it appears important to have a low emissivity to maintain high collector efficiencies. Unfortunately, for cavity type receivers, it is extremely difficult to achieve a low value of effective emissivity. A plot of effective emissivity as a function of A_w/A_o for various values of surface absorptance or emittance (Ref. 2) is shown in Figure 6. Note that at $A_w/A_o = 5$ a surface emittance of 0.1 results in an effective emittance of nearly 0.4.

The optical parameters that correspond to the curves in Figure 5 are given in Figure 7. At a mirror quality of 8 mrad the optical concentration (ratio of concentrator aperture area to receiver aperture area) is from 250 to 280 at a 500°C receiver temperature. With a high quality concentrator (2 mrad) the concentration ratio is about 1500, meaning that

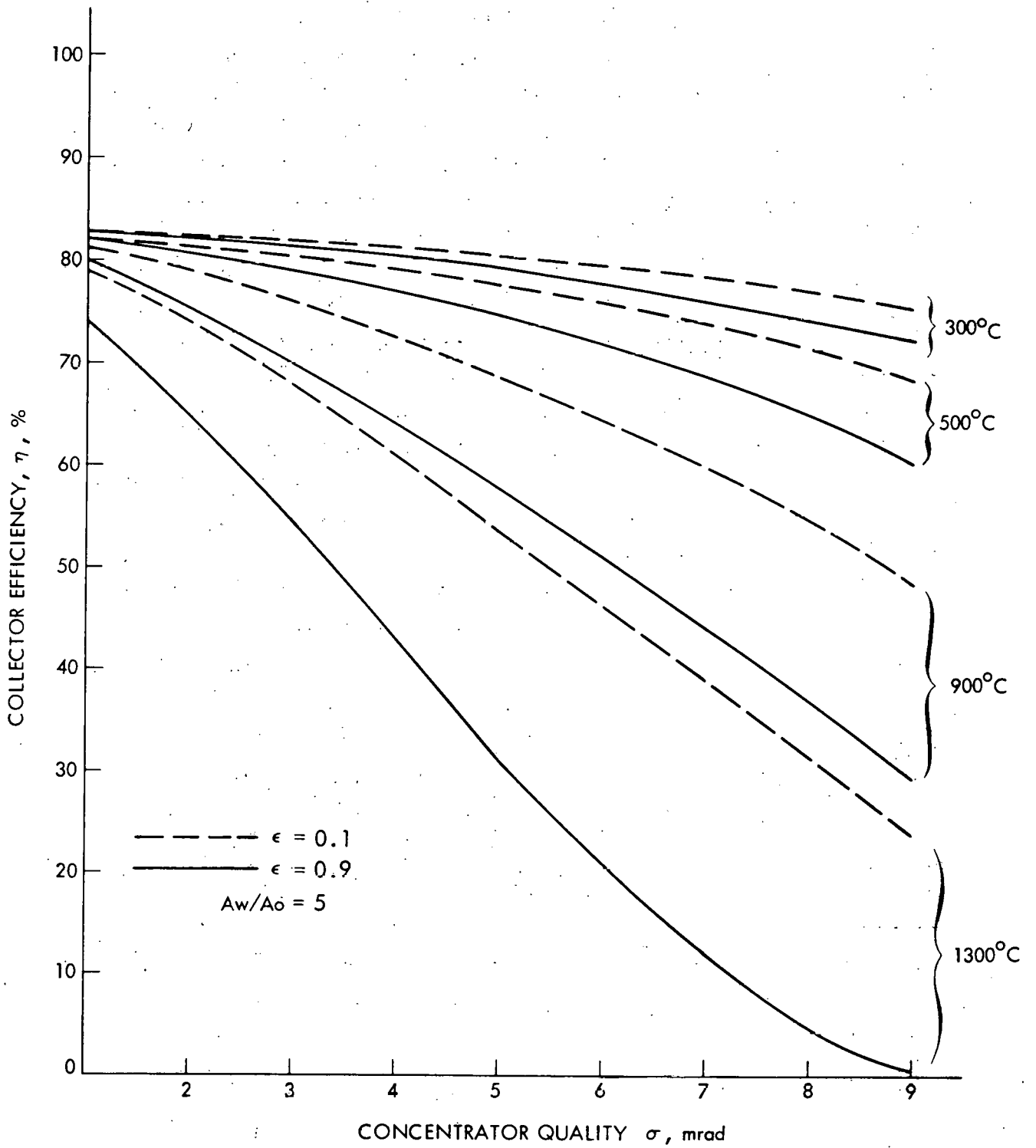

Figure 5. Collector Efficiency vs Concentrator Quality

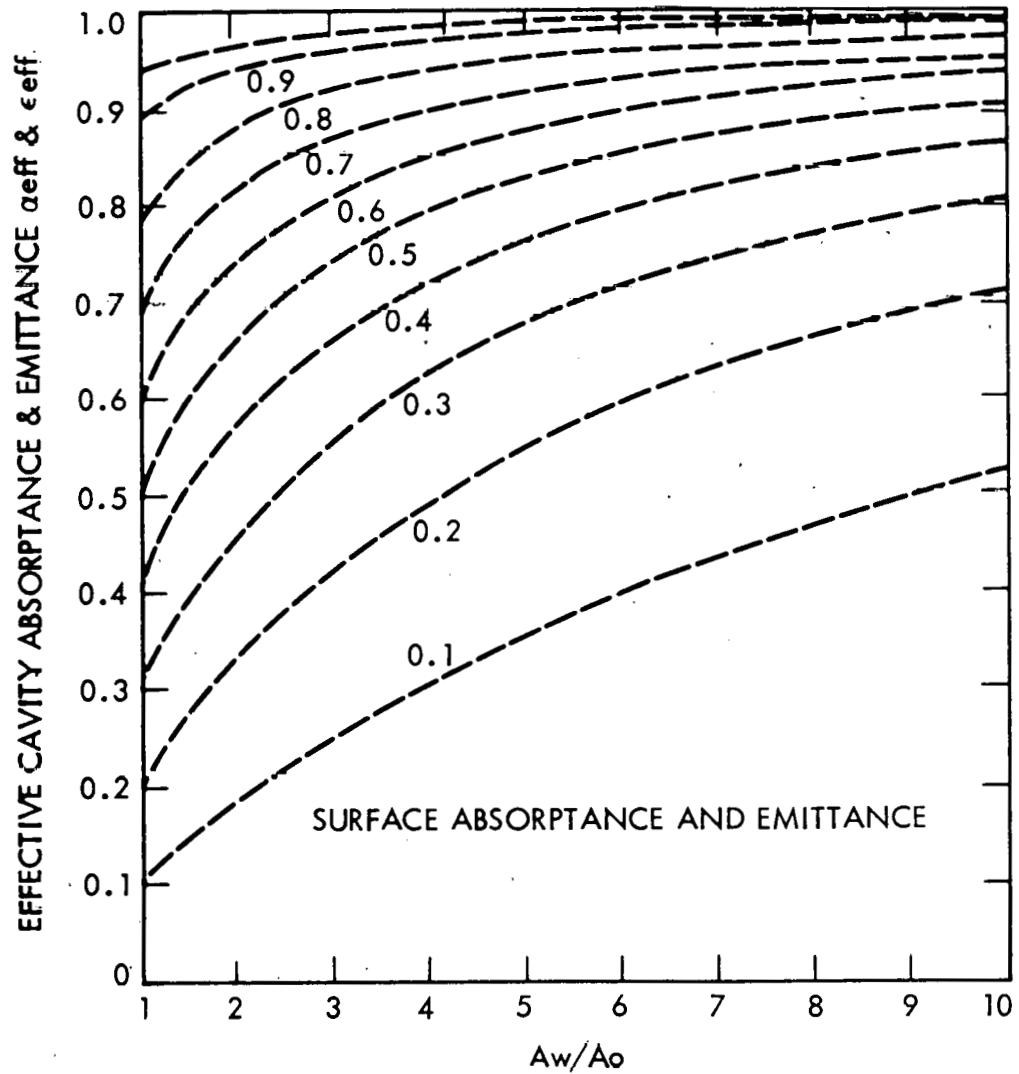

Figure 6. Effective Cavity Absorptance and Emittance vs A_w/A_o

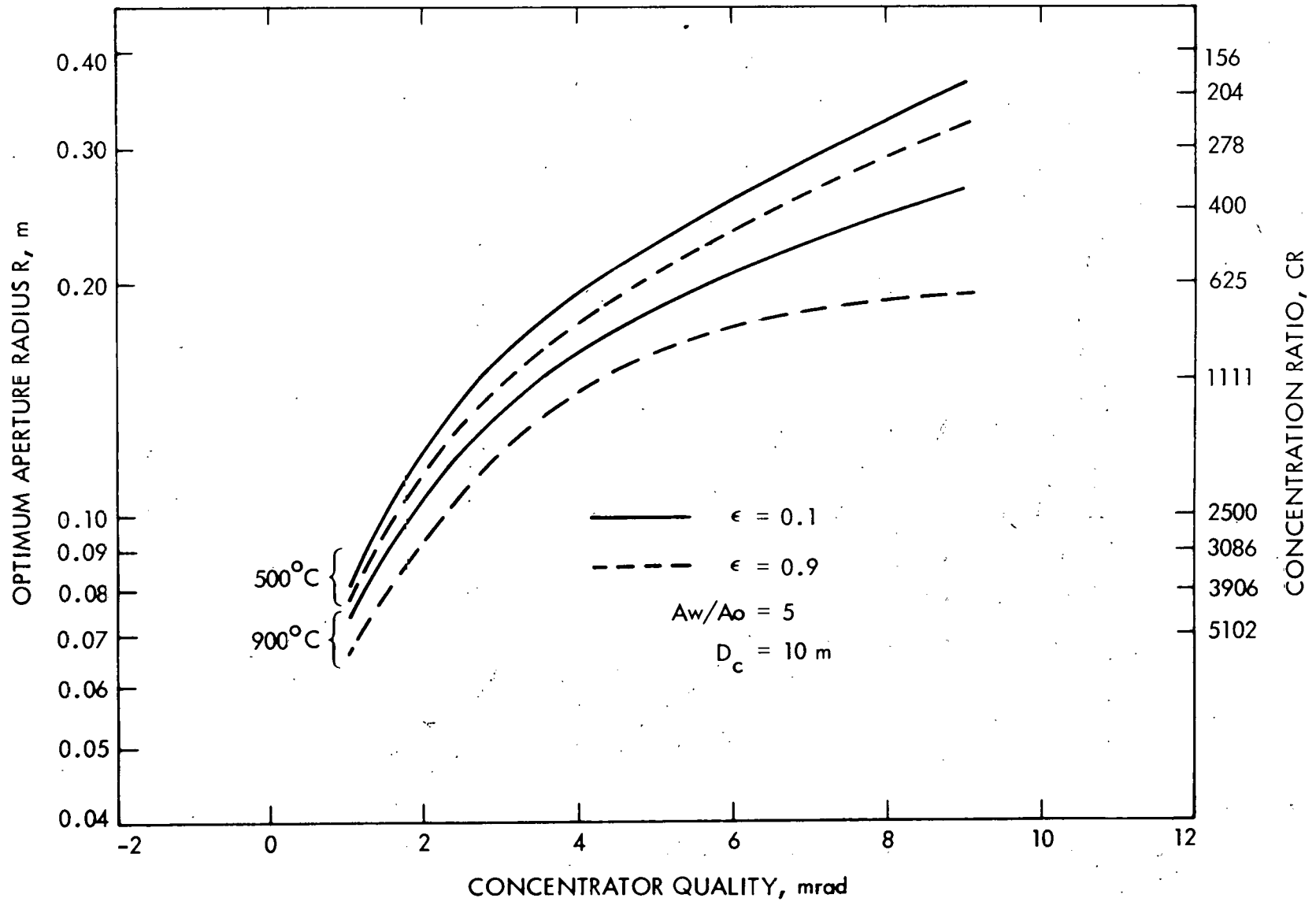

Figure 7. Aperture Radius and Concentration Ratio vs Concentrator Quality for Cavity Receiver

the allowable receiver aperture is much smaller with correspondingly lower reradiation losses and higher collection efficiency.

As was pointed out earlier, the collector efficiency shown in Figure 5 assumed a reflectivity versus spreading angle (ω) based on the top curve of Figure 2(a). This curve assumes very little spreading (< 1 mrad) of beam, i.e., a very specular surface. It is of interest to compare the performance of a collector having a very specular surface with one that is less specular, both having the same value of total hemispherical reflectivity. Referring to Figure 2(a), we note that the reflectivity curves for Corning 0317 glass and that of Corning silvered microsheet show a total hemispherical reflectivity of about 0.95; however, the microsheet is much less specular, i.e., has greater spreading of the beam. The resultant collector efficiencies are compared in Figure 8. Note that even though the specularities are significantly different, there is little difference in collector efficiency. The reason this occurs is that most of the energy is located near the center of the receiver aperture and not near the edge. Thus, the implication is that a modest amount of spreading does not significantly effect performance, and that a highly specular surface is really not required.

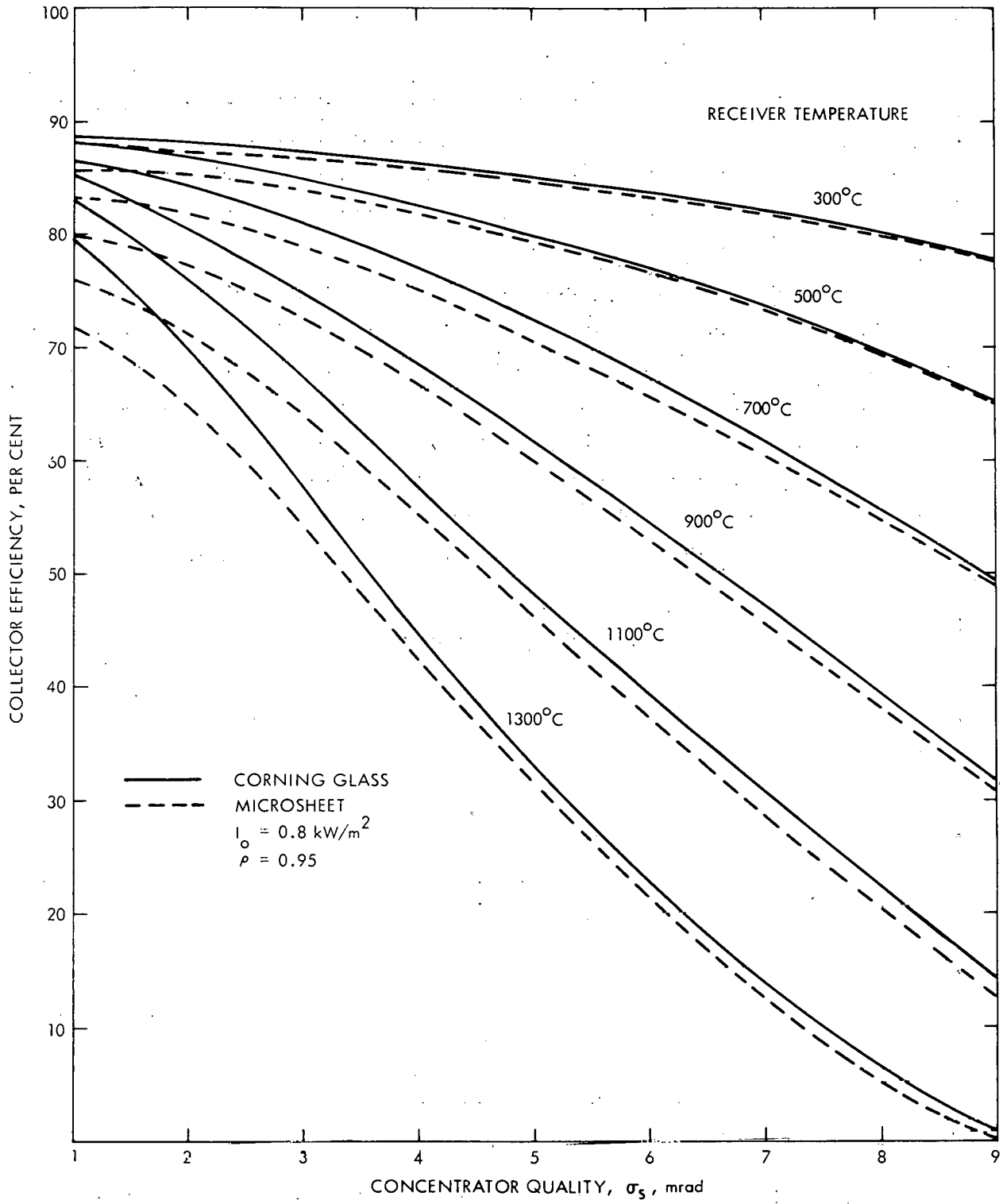

Figure 8. Collector Efficiency

C. Pointing Error

In general, the geometrical center of the receiver does not coincide with the center of the solar image due to the concentrator pointing error. The pointing error includes inaccurate sun tracking, misalignment and receiver supporting structure deflections caused by gravity and wind loads. An expression for intercept factor ϕ has been derived at JPL (Ref. 3) as a function of pointing error (δ), receiver aperture (R), and the flux distribution $f(Z)$ at the focal plane. The geometry is shown in Figure 9. The final result is expressed below:

$$\phi(R, \delta) = \int_{\delta-R}^{\delta+R} 2Z f(Z) \cos^{-1}(\gamma) dZ, \quad \delta > R$$

$$\int_0^{R-\delta} 2\pi Z f(Z) dZ + \int_{R-\delta}^{R+\delta} 2Z f(Z) \cos^{-1}(\gamma) dZ, \quad 0 \leq \delta \leq R$$

where $\gamma = \frac{Z^2 + \delta^2 - R^2}{2\delta Z}$

In the above equation obviously it is necessary to have a description of the flux distribution, $f(Z)$, at the focal plane. If the distribution were assumed Gaussian, it could be expressed analytically. However, in general, $f(Z)$ will not be so simple, and the use of a digital computer analysis is often found to be necessary to evaluate this expression. An example of the results of such an analysis is shown in Figure 10.

Another important aspect of the pointing error problem relates to recent information generated at JPL suggesting that certain pointing errors can be virtually eliminated from consideration through proper sensing and control. These errors would include those due to alignment, receiver sag, atmospheric refraction and steady winds. Transient pointing errors, due to wind gusts, must still be considered, but with a fast response control system such that the concentrator is quickly brought back to accurate pointing, little energy is lost.

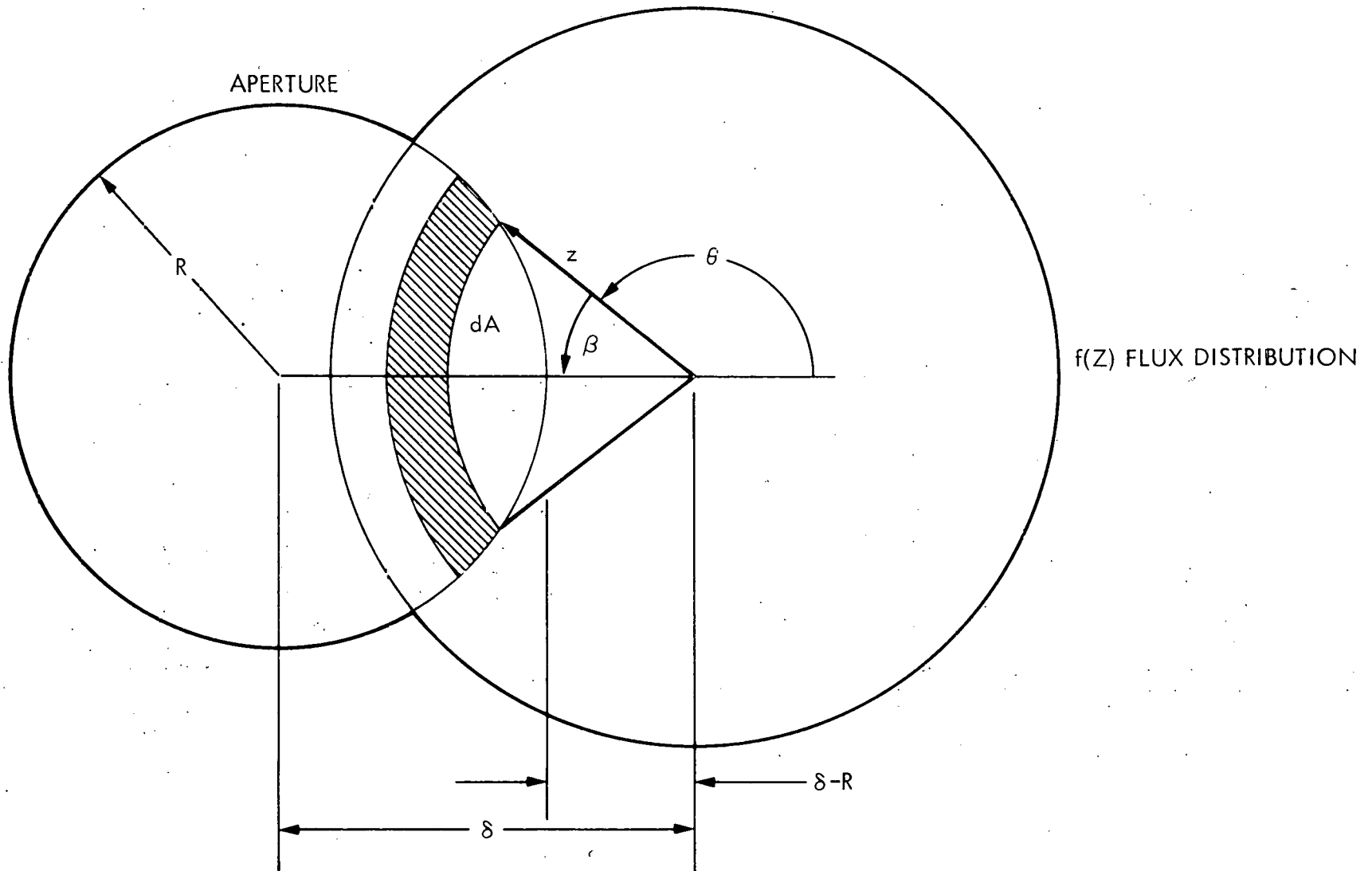

Figure 9. Radially Symmetric Flux Distribution

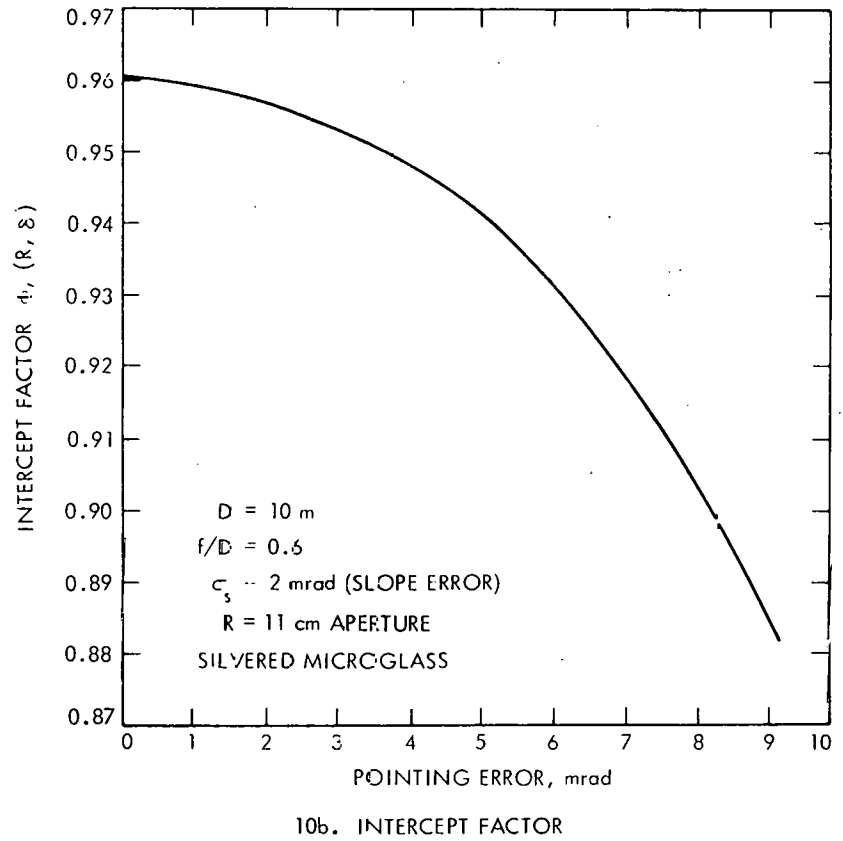
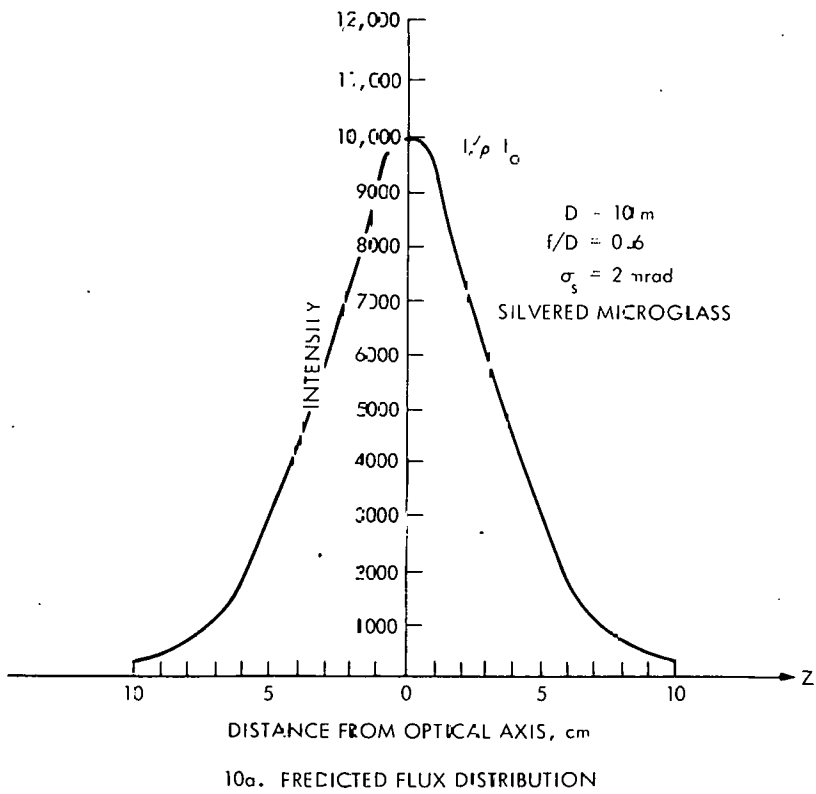

Figure 10. Intercept Factor Evaluation

D. Collector Cost versus Quality

So far we have discussed the performance of concentrating collectors as a function of the quality of the surface. The conclusion one might reach is that the highest quality surface is the best because it gives you the smallest solar image and, thus, the highest collector efficiency. This argument totally disregards cost. In fact, it may well be that a poorer quality concentrator is preferred over one of higher quality if the cost were low enough. To obtain the optimum collector design, a figure of merit can be defined as shown in Table 1. The figure of merit is the ratio of the energy absorbed by the receiver at the specific temperature and the collector cost. The higher this ratio, the better the collector. As shown in Figure 11, as concentrator optical quality is increased, both collector cost and efficiency increase. The optimum quality is that point which maximizes the figure of merit. It is important to recognize that optical quality considers all factors that influence the size and location of the solar image such as surface inaccuracies, surface reflectivity and pointing errors. Moreover, the collector cost must consider all factors such as cost of surface, substrate, structure, tracking mechanisms and bearings as well as the cost of the receiver. Because of the complexity of these considerations, there is little present in the literature regarding the relationship between collector cost and optical quality. The problem becomes even more complex when the issues of receiver temperature and power conversion are introduced. A higher temperature may result in greater system performance because of the increased efficiency of the power conversion unit. However, to collect at higher temperatures, better quality optics are needed which increase collector costs. Clearly, an optimization study can and should be performed. Considerable work in this area needs yet be done before properly optimized systems are developed.

Table 1. Collector Figure of Merit

$$FM = \frac{\text{Btu}}{\$/\text{ft}^2}$$

$\rho(w)$
(REFLECTIVITY)

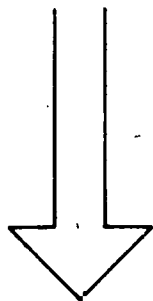

REFLECTIVE SURFACE

- FILM
- GLASS
- POLISHED SURFACE
- CHEMICALLY BRIGHTENED

ϵ_s
(SURFACE QUALITY)

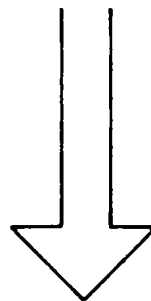

SUBSTRATE FABRICATION

- STRETCH FORMING
- CASTING
- GRINDING
- SPINNING

ϵ_p
(POINTING ERROR)

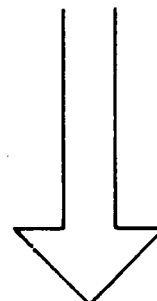

CONTROL AND STIFFNESS

- CONTROL COST
- STRUCTURE COST

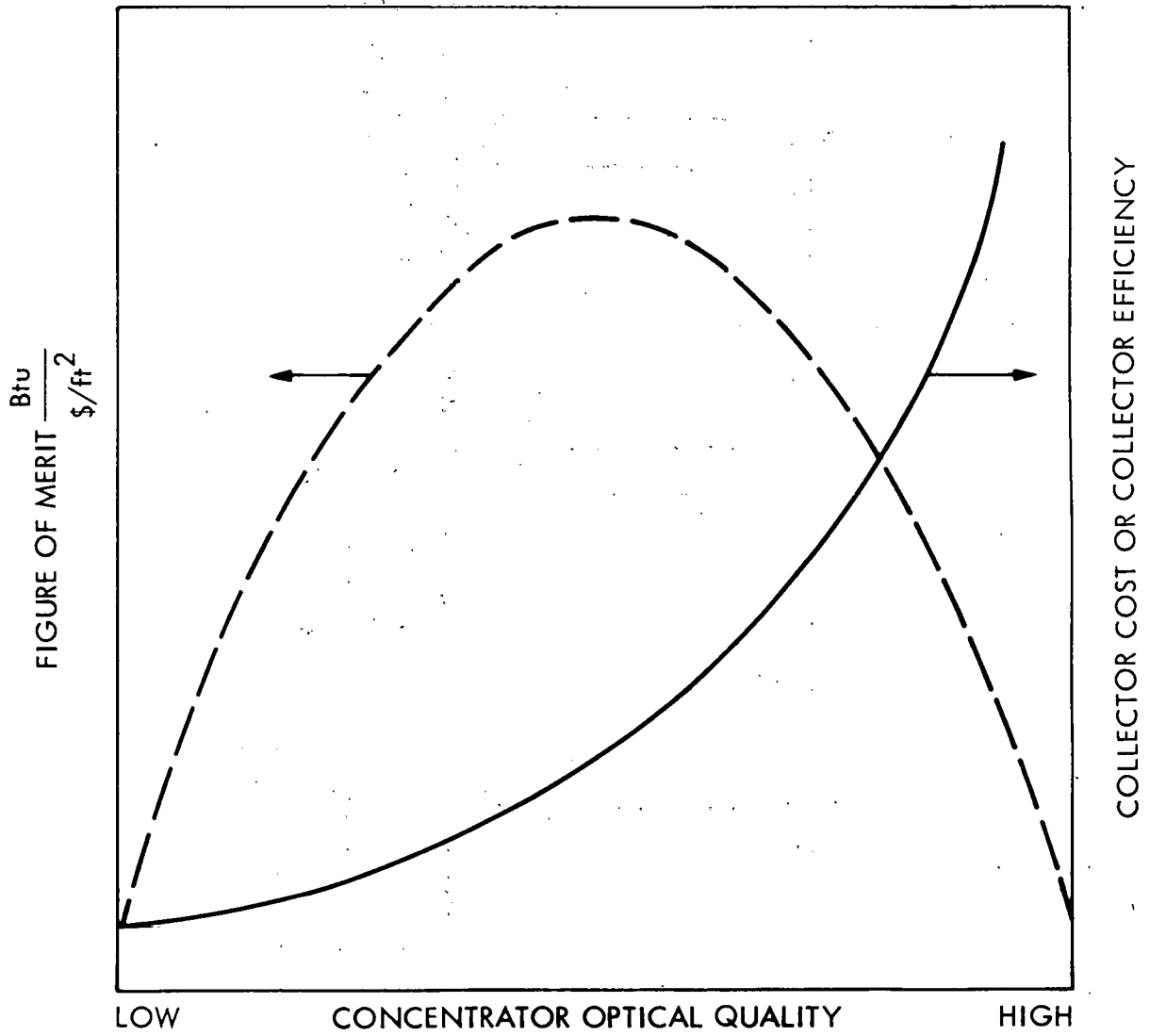

Figure 11. Collector Figure of Merit vs Concentrator Optical Quality

E. System Performance

In the previous section it was implied that increasing receiver temperature can lead to improved system performance, but that cost might also be significantly increased. It can also be shown that, above certain temperatures, little is gained with respect to performance by further increases in temperature. Figure 12 is a plot of system efficiency (product of collector and engine) versus receiver temperature parametric with percent of Carnot efficiency. These curves, based on perfect optics (i.e., the receiver aperture corresponds to the solar image), indicate that, above about 1000-1200°C, little is gained in system efficiency. The reason is that the solar image size is fixed, and going to higher temperatures increases the reradiation from the receiver aperture more rapidly than it increases conversion efficiency. When real optics are considered, the situation is even worse and temperature of about 800-1000°C probably should not be exceeded.

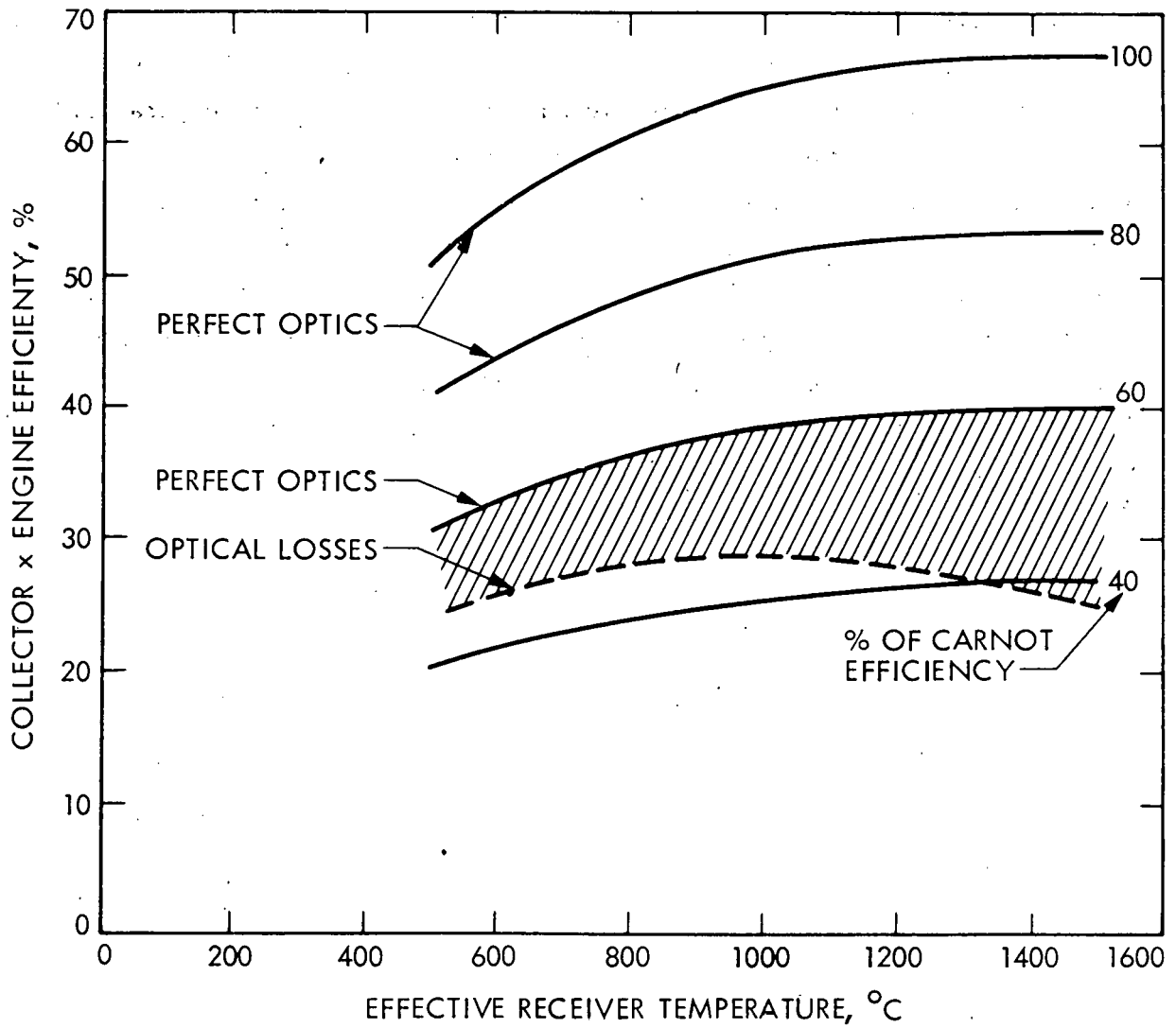

Figure 12. System Performance

THIS PAGE INTENTIONALLY LEFT BLANK

III. Collector Types

There are a number of variations of the point-focusing parabolic concentrating collector. The conventional type is termed a deep dish (Figure 13a) in which the receiver is located at the focal point and accepts energy from single reflections. A variation of this is shown in Figure 13b in which a secondary reflector (CPC) is placed at the receiver to redirect and better focus the energy into the cavity. Such a design enables the use of a poorer quality concentrator with a high concentration receiver. Another version has a secondary reflecting surface (Figure 13c) so that the receiver can be located at or near the tracking axis. This configuration, known as a Cassegrainian, has certain design advantages, but has the basic disadvantage of additional reflections. It is also possible to replace the parabolic reflecting surface with a flat-plate reflecting Fresnel lens (Figure 13d). Finally, a curved refracting Fresnel lens is possible and has many inherent advantages (Figure 13e), the most important being a lightweight structure.

Up to this point the collector types discussed have been two-axis tracking collectors for which the concentrator is continually pointed at the sun, redirecting and concentrating the sun's energy into a receiver which remains at the focal point of the collector. Another class of essentially a point-focusing collector is the fixed mirror concept in which the receiver is the only element of the collector which articulates and maintains itself roughly in the focal region of the rays reflecting from the fixed concentrator surface. At least two versions have been proposed. One version, under development by E-Systems, is known as the Fixed Mirror Distributed Focus Concept (Figure 14), and has an aperture diameter of from 200-300 feet. The collector can produce about 1000°F heat with a concentration ratio of about 1000. A more modest version has recently been suggested by Meinel of the University of Arizona, having an aperture diameter of 5 to 10 feet. It produces temperatures of 300°C at a concentration ratio of only about 10-20. Both of these concepts use a spherical mirror surface and are fashioned after the early work of Steward and Kreith (Ref. 4) on small diameter fixed mirror concepts.

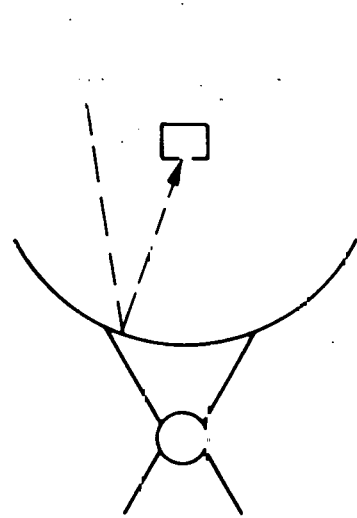

(a) DEEP DISH PARABOLA

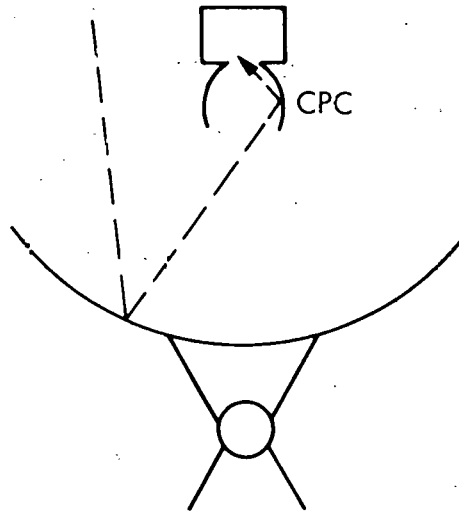

(b) PARABOLIC WITH CPC

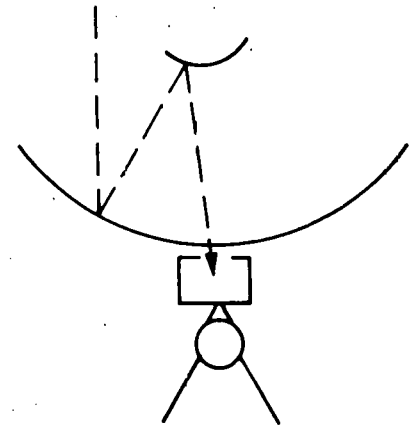

(c) CASSEGRAINIAN

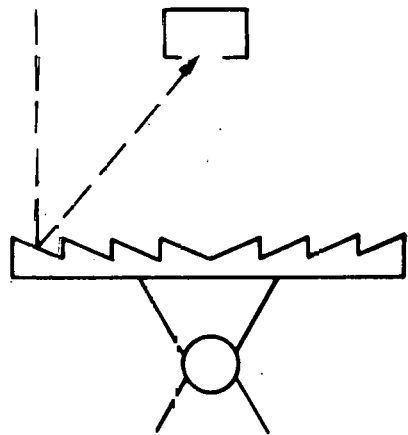

(d) FLAT PLATE REFLECTING FRESNEL

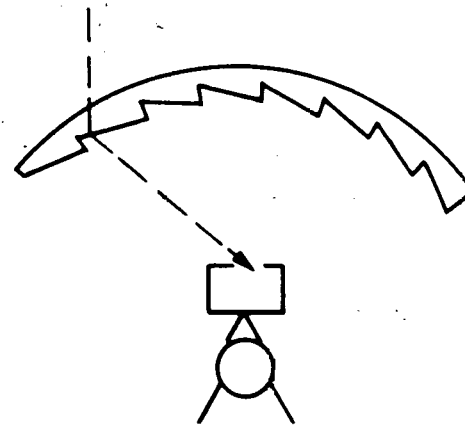

(e) CURVED REFRACTING FRESNEL

Figure 13. Collector Types

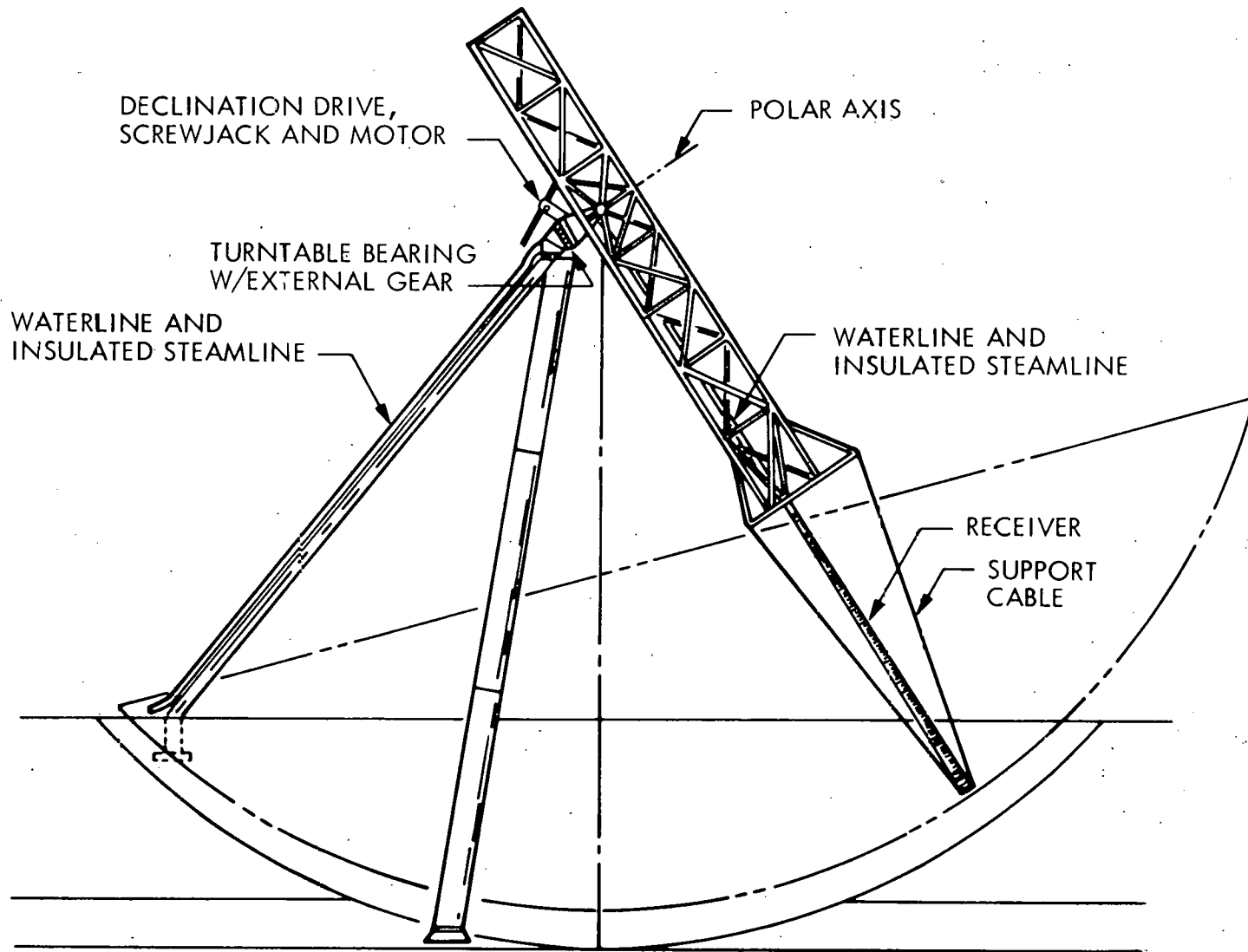

101

Figure 14. Fixed Mirror Distributed Focus Concept

The fixed mirror distributed focus (FMDF) concept does not focus energy at a single point, but rather along a line, either cylindrical or conical surface (see Figure 15). Because of this feature and unavoidable cosine losses, the FMDF system has a lower collection efficiency than those concepts in which the concentrator articulates. Its main advantage is the potential lower cost associated with a concentrator structure that does not need to articulate.

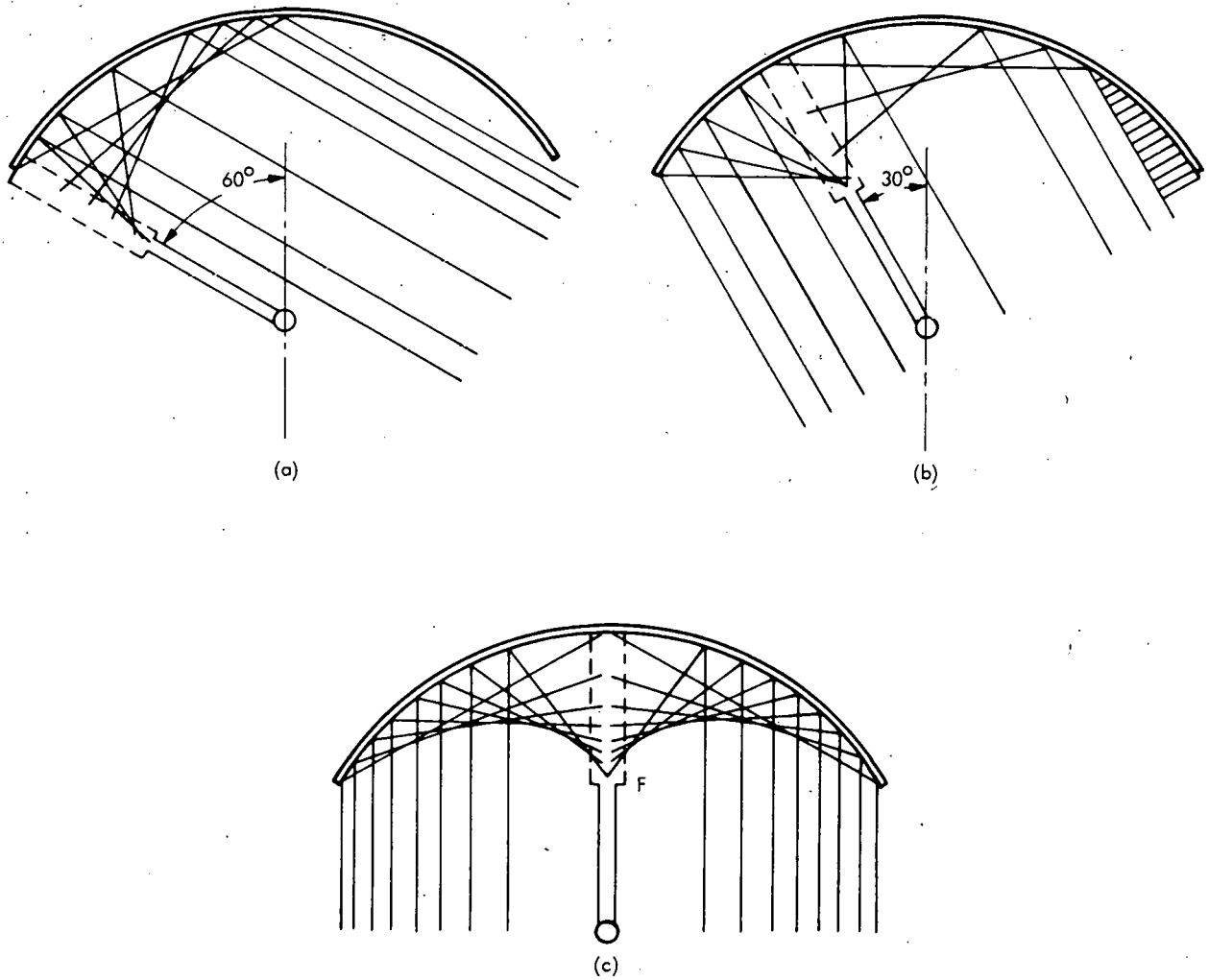

- (a) POSITION OF THE ABSORBER AT 8:00 A.M. OR 4:00 P.M.
- (b) POSITION OF THE ABSORBER AT 10:00 A.M. OR 2:00 P.M.
- (c) POSITION OF THE ABSORBER AT 12:00 NOON

Figure 15. Optical Principles of FMDR System

THIS PAGE INTENTIONALLY LEFT BLANK

IV. Present Development Programs

As indicated in the last section, until recently very little work was done in the development of point-focusing distributed receiver (PFDR) systems. The Government now has a very active program to develop this concept. JPL has been selected by DOE to manage an industrial program that will lead to evolving low-cost, high-performance options of the PFDR. This program recognizes that parabolic concentrators can be coupled with a number of energy transport and power conversion techniques. The energy transport options are

- 1) thermal
- 2) chemical
- 3) electrical

Thermal transport systems, in which a group of collectors are interconnected and thermal energy transported to a central heat engine, are limited to about 1000^oF operation because of the difficulty of transporting high temperature heat by piping. Chemical transport avoids this high temperature transport problem by converting the thermal energy at the receiver into potential energy in a chemical. By removing any sensible heat, relatively low temperature gases or liquids are transported to a central heat engine where reconversion to heat, and then electricity, can occur. In electrical transport, the heat absorbed by the receiver is immediately converted to electricity by a small heat engine located at or near the focal area. Electricity is then transported from each collector. These three concepts are schematically represented in Figure 16.

The power conversion systems that may be coupled with these types of collectors can be based on Rankine, Brayton or Stirling cycles. With our present level of understanding, any of these three conversion systems are felt to be capable of leading to attractive, cost-competitive power plants. The Government's program is presently structured to develop and mature various collector, receiver and heat engine options. A program to develop a low-cost, high-performance point-focusing concentrator has been initiated. Proposals are presently being evaluated in order to

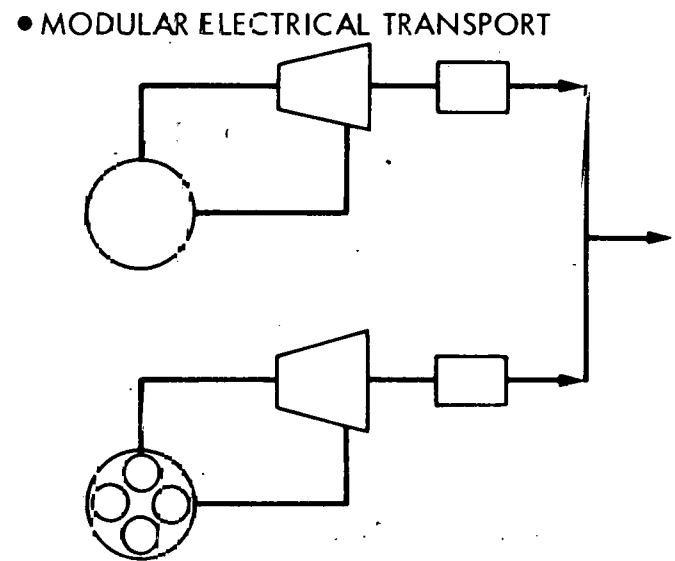
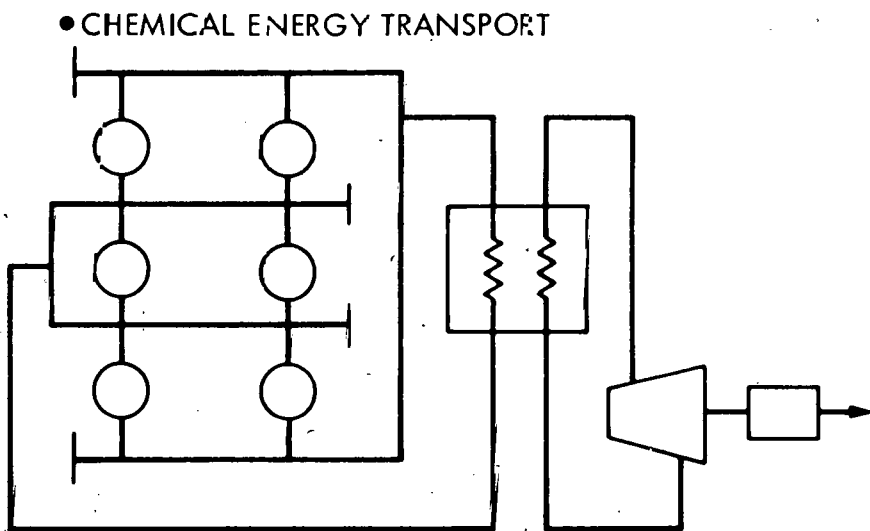
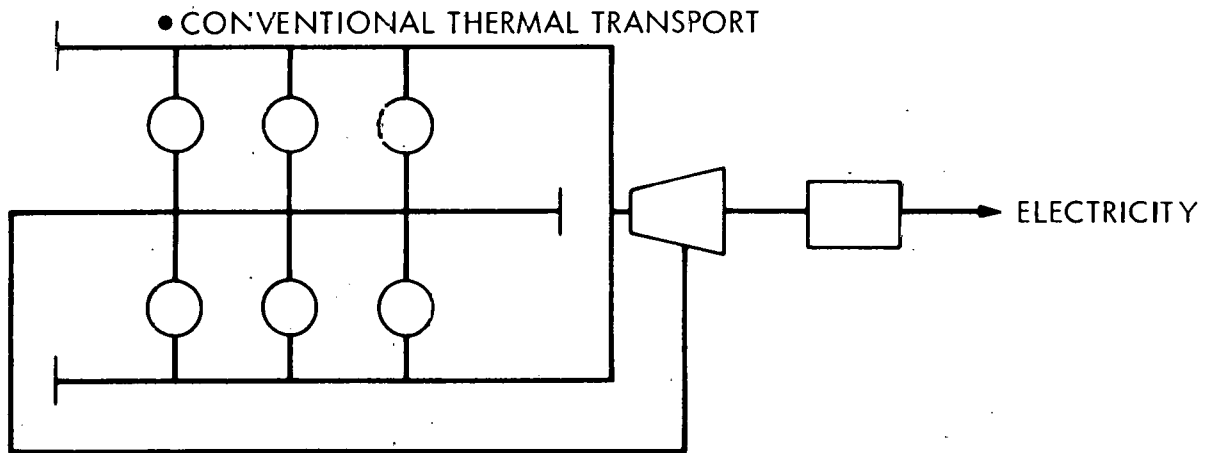

Figure 16. Transportation Concepts for Distributed Dish Concentrators

select three contractors for concept definition and mass production cost estimating. By the end of June 1978, contracts will have been negotiated with a number of industrial firms for the development of gas and steam receivers and the development of small Stirling, Rankine and Brayton heat engines.

An overview of the schedule for hardware development and test program is shown in Figure 17.

In addition to this effort by JPL in developing PFDR concepts for electric power applications, work is underway by Sandia (Albuquerque) to develop the parabolic point-focusing concentrator collector for lower temperature applications (about 600-750°F) for use in irrigation or total energy systems.

Sandia is developing two concepts of the parabolic collector. One is being developed for them by Raytheon and the other by General Electric. The Raytheon collector (Ref. 5) is about 6.7 m in diameter with an f/D of 0.45. It consists of spherical mirror segments hard mounted on an aluminum substructure. The mirrors are sagged, water white crystal glass and back-silvered to provide a specular reflectance of about 0.9. The collector is driven in azimuth and elevation by dc stepping motors. The drives are computer controlled in an open-loop incremental manner. The elevation drive system consists of a ball screw driven by a worm gear reducer from the stepping motor. A double-reduction chain drive and worm gear comprise the azimuth drive system. An artist's conception of the collector is shown in Figure 18. One of these units is presently under test at Sandia.

The GE concentrator is a modified scientific-Altanta antenna with a diameter of about 7 m. It uses aluminized acrylic, FEK-244 (made by the 3M Company) bonded to a solid aluminum substrate. The support structure is a tripod type pedestal. The energy is focused onto a cavity-type receiver with a concentration ratio of about 250. An artist's conception of a field of these collectors is shown in Figure 19. The collector field will power a total energy system for a knitware factory in Shenandoah, Georgia. A five-foot prototype of the collector unit has

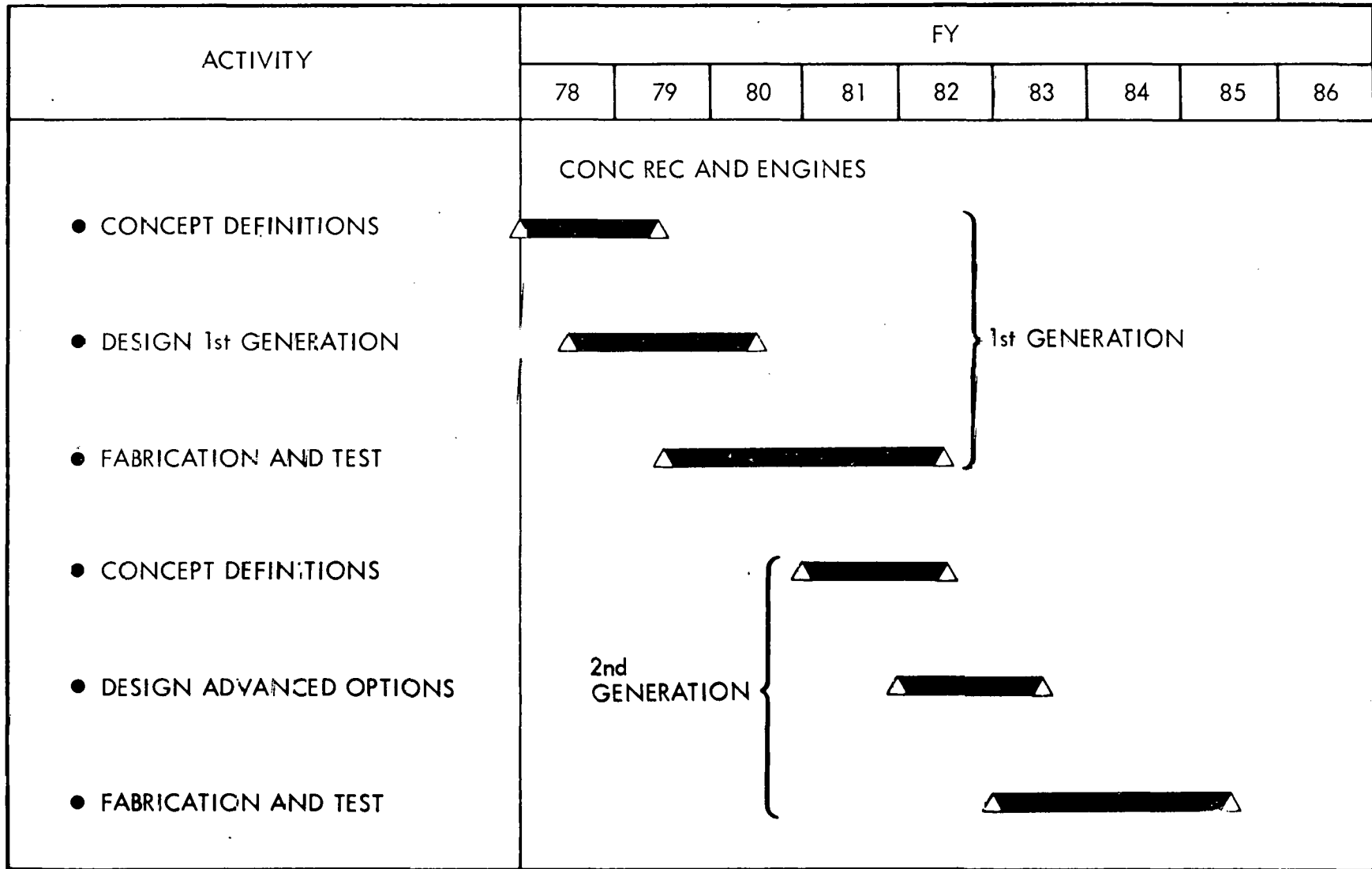

Figure 17. PFDRT Schedule

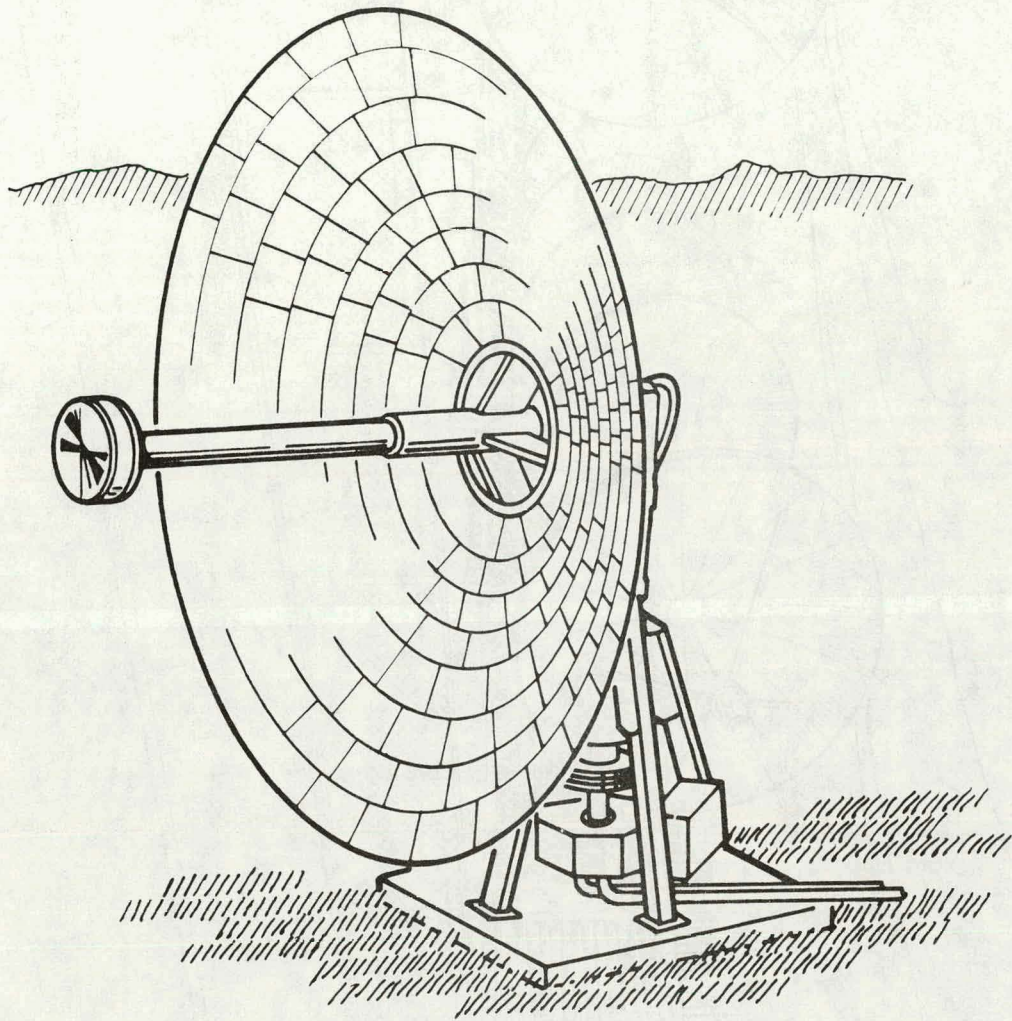

Figure 18. Raytheon Point-Focusing
Concentrator Collector

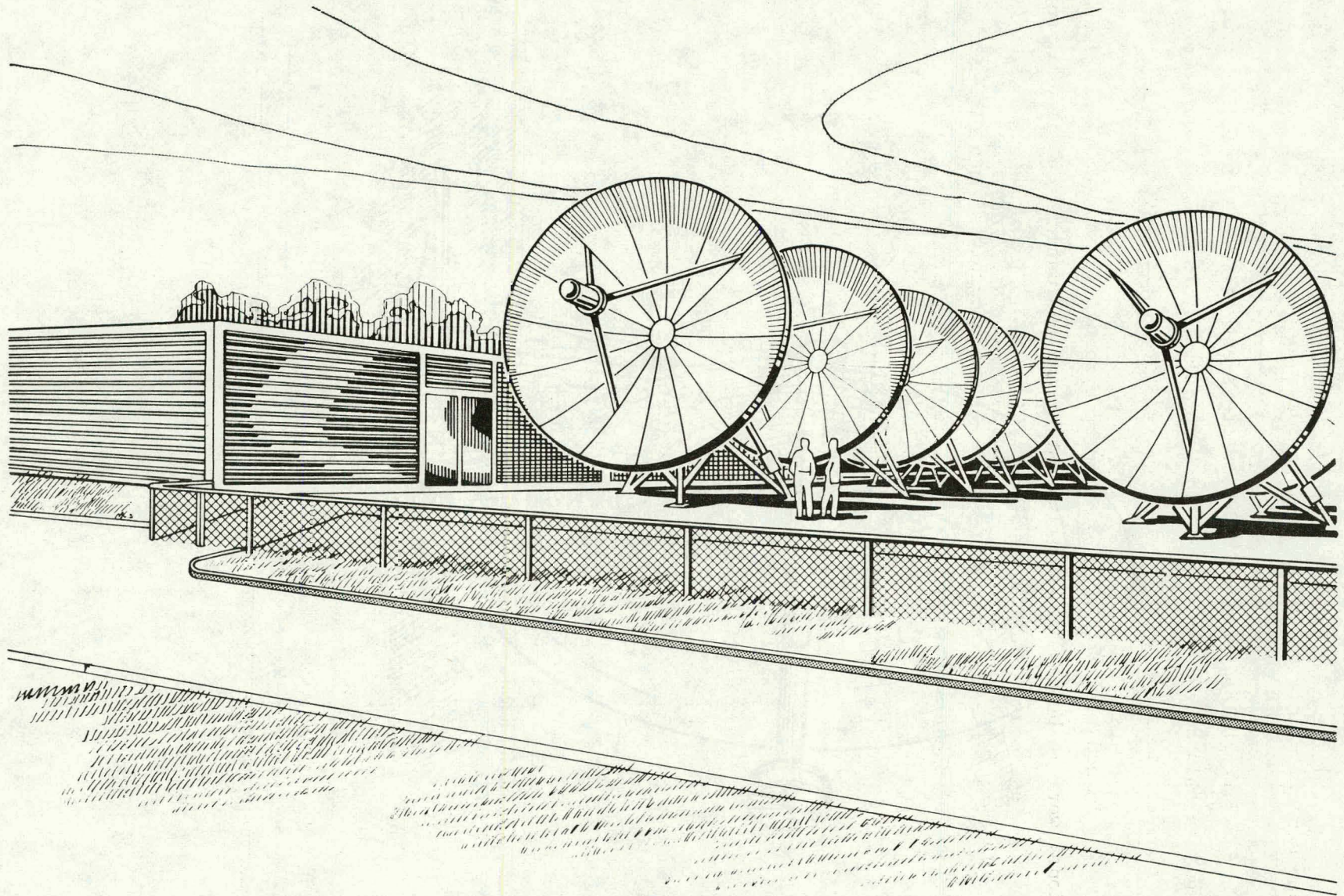

Figure 19. General Electric Parabolic Collectors (Shenandoah)

been sent to Sandia for tests (Figure 20).

Both the Raytheon and GE collectors are designed to collect thermal energy within a cavity receiver. In application, the energy would be transported to a central point for conversion to electricity.

In addition to the efforts in developing PFDR concepts, some additional work is being performed in testing and evaluating the fixed-mirror distributed focus collector concept. This work is being done both by E-Systems and the University of Arizona. A photograph of a prototype version of the E-System collector is shown in Figure 21.

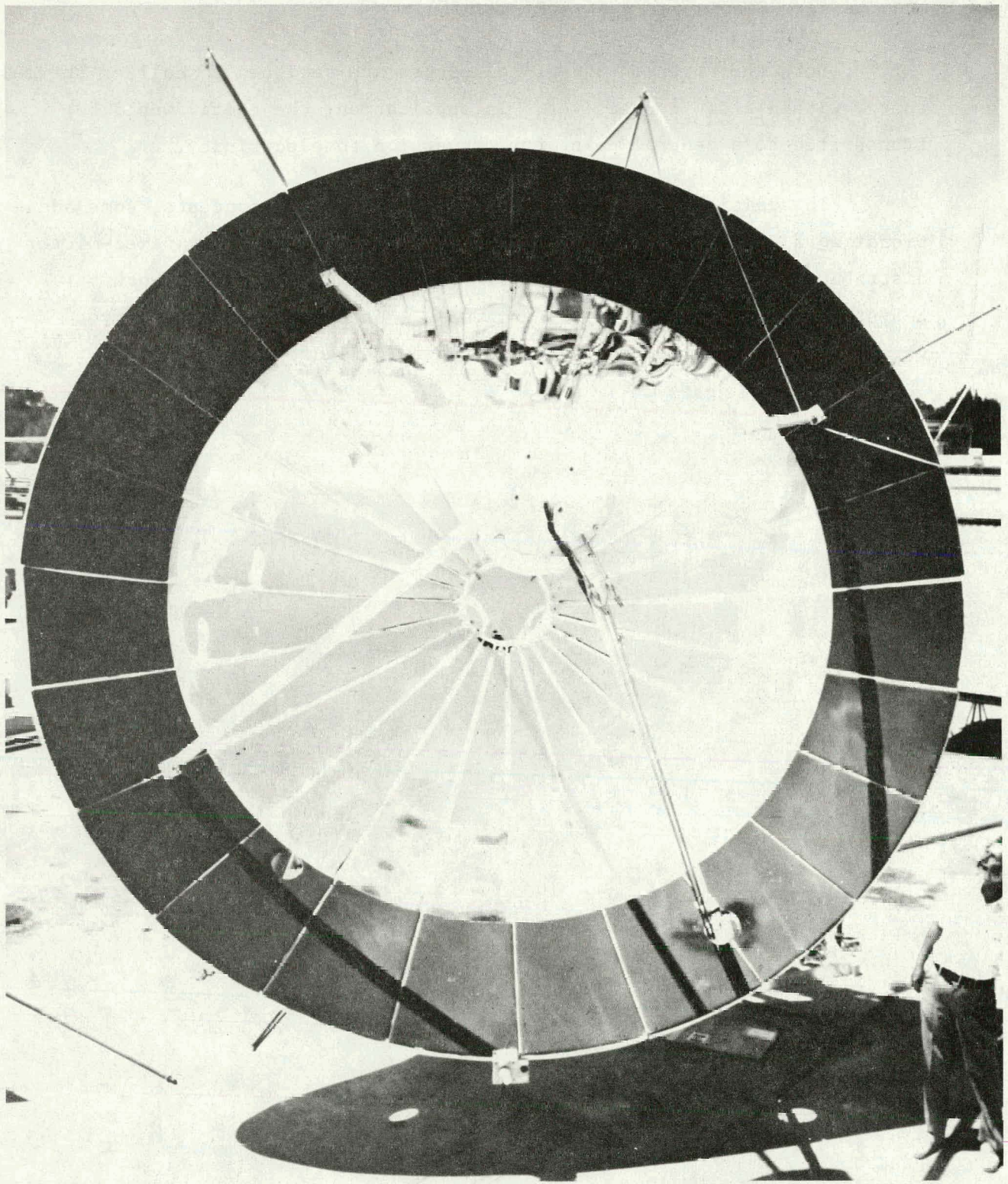

Figure 20. Engineering Prototype Collector

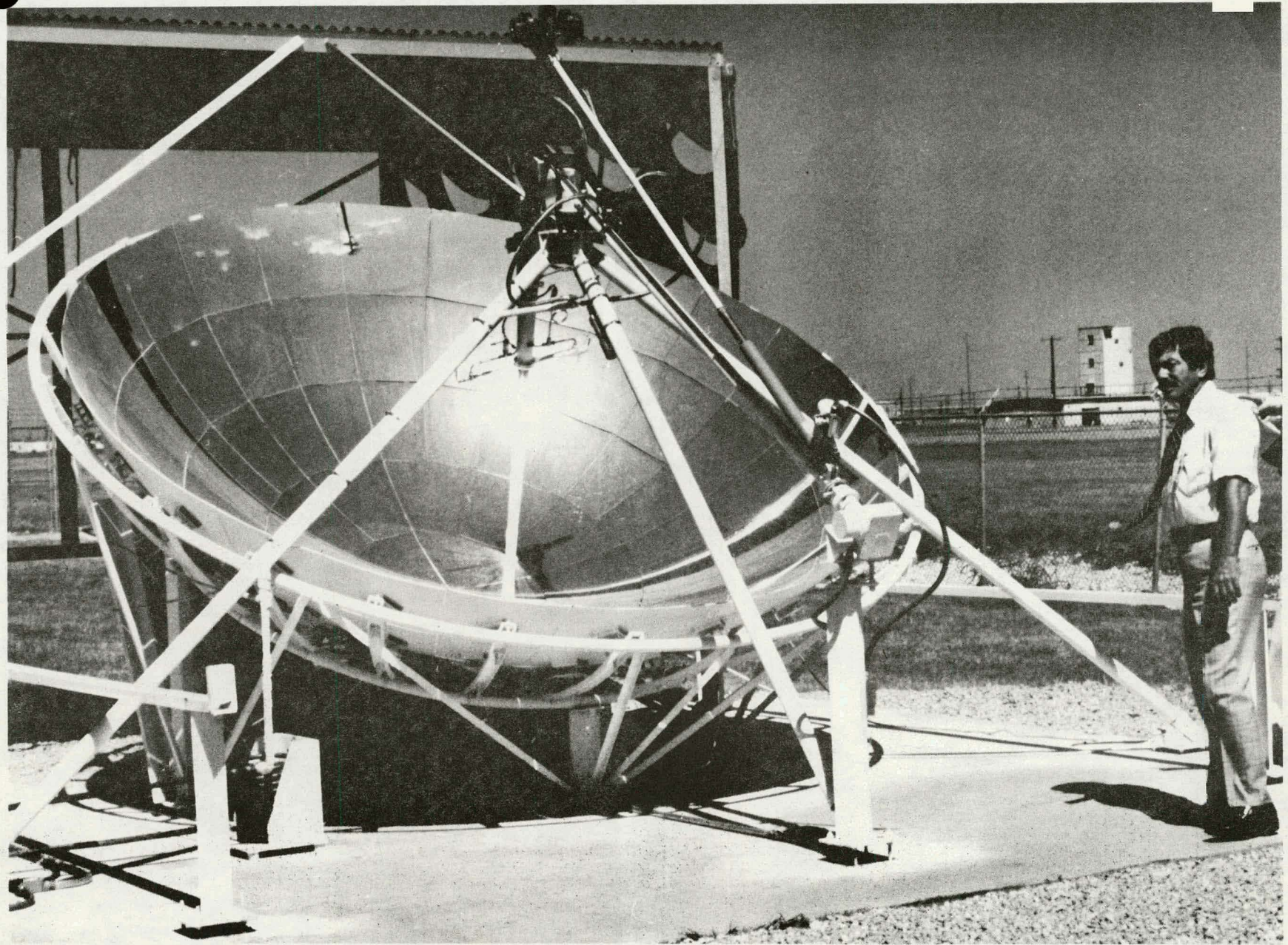

Figure 21. Prototype of Fixed-Mirror Distributed Focus Collector

THIS PAGE INTENTIONALLY LEFT BLANK

V. Cost Estimates

No firm cost data are yet available for the parabolic point-focusing collector in production quantities. In fact, only several of these units have been built to date. The only commercially available parabolic collector is one produced by Omnium-G, located in Anaheim, California (Figure 22). This company is producing a 6m collector in small quantities at a sale price of around 1000 $\$/\text{m}^2$. The collector has an f/D of 0.67 and an electro-polished aluminum surface. The only other units available are the prototype versions of the Raytheon and GE collectors discussed previously. Cost estimates for these units in prototype versions are in the 1000-2000 $\$/\text{m}^2$ range.

Microwave antennas that are similar in construction are being built for 500-750 $\$/\text{m}^2$ in very modest quantities (< 100 per year).

Considerable cost reduction in parabolic collectors is both necessary and probable with mass production and proper structure design.

The Department of Energy's goals for PFDR technology, including the parabolic concentrator, are shown in Table 2. The long-range goal for concentrators in mass production is 70-100 $\$/\text{m}^2$. Present estimates indicate that most of the cost of a parabolic concentrator (~80%) is associated with those parts of the concentrator other than the surface (re the bearings, tracking mechanisms, structure, and foundations). However, the weight and structural stiffness of the concentrator surface can markedly affect the design (thus cost) of the other components. With the use of advanced concentrator surface structural materials, such as cellular glass and high quality reflective surfaces, such as microsheet glass, a total low cost concentrator design is felt possible, one that can meet the cost goals in mass production.

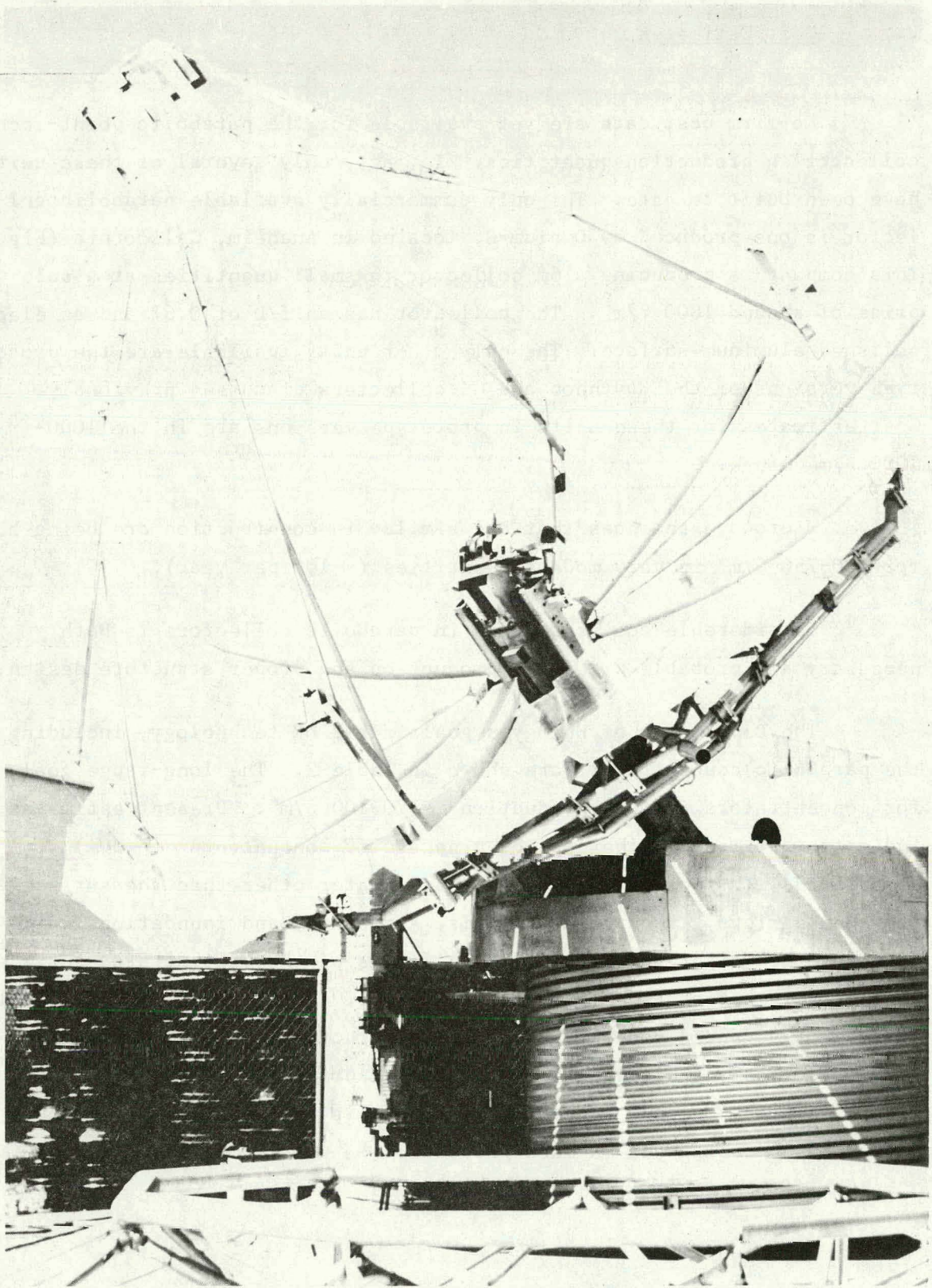

Figure 22. Omnim-G Collector

Table 2. Cost and Performance Targets

TEST AND EVALUATE	TARGETS FOR FY	1982	1985
CONCENTRATORS	COST IN MASS PRODUCTION	\$100-150/m ²	\$70-100/m ²
	REFLECTOR EFFICIENCY	90%	92%
RECEIVERS AND ENERGY TRANSPORT	COST IN MASS PRODUCTION	\$30/kWe	\$20/kWe
	EFFICIENCY	80%	85%
POWER CONVERSION	COST IN MASS PRODUCTION	\$75/kWe	\$60/kWe
	EFFICIENCY	25-35%	35-45%

THIS PAGE INTENTIONALLY LEFT BLANK

VI. References

1. L. Wen, "Thermal Optical Surface Properties and High-Temperature Solar Energy Conversion," Proceedings of AIAA 78:903.
2. Y. Wu, personal communication.
3. R. O. Hughes, personal communication.
4. W. G. Steward and F. Kreith, "Stationary Concentrating Reflector cum Tracking Absorber Solar Energy Collector: Optical Design Characteristics," Applied Optics, Vol. 14, No. 7, July 1975.
5. L. Paradis, et al, "Parabolic Collector for Total Energy Systems Application," Proceedings of ISES, 1977.

ACKNOWLEDGMENTS

Most of the technical information presented in this paper was compiled from papers and memos written by members of my staff over the past year or two.

The author's main contribution has been in reformatting the information in layman's language as a tutorial rather than a rigorous analytical presentation. Some liberties in interpretation were taken in order to accomplish this objective.

The time spent by my staff explaining the more fundamental aspects of this subject to me is greatly appreciated. The support of Drs. L. Wen, M. Adams, Y. Wu and R. Hughes was particularly helpful.

This paper was prepared by the Jet Propulsion Laboratory, California Institute of Technology, for the Department of Energy, Division of Solar Energy under the Interagency Agreement, EX-76-A-29-1060, with the National Aeronautics and Space Administration.

Dup

THE SOLAR THERMAL TEST
FACILITY HELIOSTAT DEVELOPMENT

by

D. E. Arvizu
Sandia Laboratories

INTRODUCTION

The solar concentrator, or heliostat, subsystem is very influential in determining economic and technical effectiveness of a central receiver power plant. Since the heliostat field is projected to account for about one-half the total power plant cost, the heliostat design must be carefully engineered in a cost effective manner for this technology to be competitive. The cost of total annual collected energy is one measure of cost effectiveness.

Heliostat engineering is a relatively new field, and no satisfactory standards are yet available for defining heliostat specifications. In addition, no long term operational data are available to assess heliostat performance. The ideal specifications must include a statement of the intended use of heliostats and the minimum requirements to satisfy those uses. Currently, work is underway to establish some criteria to define the "quality" of heliostat performance. The difficulty in this task becomes apparent when the influence on "quality" of factors such as time of day/year, field location, material type, system construction, and environmental effects is considered.

This paper will present an overview of work that has been accomplished through support of the U.S. Department of Energy in conjunction with Sandia Laboratories at the Solar Thermal Test Facility in Albuquerque, New Mexico and the Technical Coordination Office for the Central Power Systems Program in Livermore, California.

BACKGROUND

Responses to a request for quote to provide the STTF with a Heliostat Array and Control system were received from four potential suppliers in December of 1975. A formal procedure for evaluating the responses was prepared with the objective of awarding the

contract to the offeror who submitted a proposal adjudged to best meet the requirements set forth in the RFQ and in a requirements specification document.

These specifications were written with the purpose of the facility in mind, primarily to provide the flexibility to test prototype components now being developed for the DOE/Utility sponsored 10MW_e Pilot Plant under the Central Power System Program. Other applications, such as test of components and subsystems of advanced solar thermal systems, test of high temperature materials, use of concentrated solar energy for high temperature chemical and metallurgical processing, test of photovoltaic panels, and test and evaluation of prototype heliostats are included in the scope of work for the STTF.

The selection of Martin Marietta as supplier of the STTF Heliostat Array and Control System was made after weighing technical quality, design flexibility, and ease of realignment and focusing. Items addressing technical merit that were included in the evaluation were performance, soundness of design, methods to resolve uncertainties, capability to withstand environments, calibration system, and focusing and alignment system.

Concurrent with the STTF heliostat selection, a two year development and testing program for the heliostats to be used in the DOE/Utility Sponsored Pilot Plant was being conducted. Four contractors built and tested the heliostats shown in Figure 1.

After a careful evaluation process, the McDonald Douglas design was selected as the conceptual design for the Pilot Plant application. With this particular design as the requirement, a request for quotation for heliostat detailed design, including prototypes for performance evaluation, was issued. The responses to this RFQ are presently being evaluated.

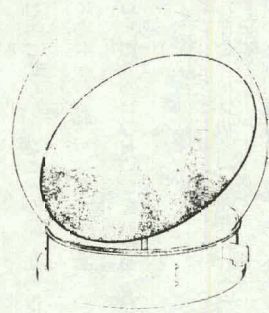

BOEING

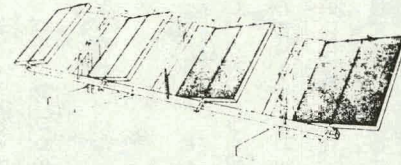

HONEYWELL

HELIOSTATS

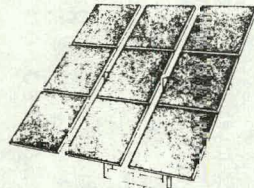

MARTIN MARIETTA

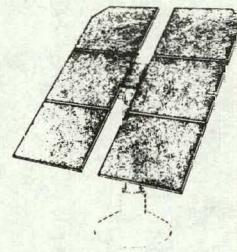

McDONNELL DOUGLAS

SL-18159A



PILOT PLANT HELIOSTATS CONCEPTS

FIGURE 1

STTF HELIOSTAT

The STTF, capable of supplying 5MW_t energy onto a target on the tower, uses an array of 222 heliostats in a north field configuration. From this heliostat array, experience is being gained. Currently the STTF is the primary source of heliostat operational data. The following is a description of the STTF heliostat together with a discussion of the performance data gathered to date.

Description

The heliostat consists of a foundation, an azimuth drive module, a yoke module, and a mirror module. The mirror module includes the elevation drive unit as an integral part of the assembly. Figure 2 shows the major components of the Martin Marietta heliostat.

Figure 3 depicts the STTF installation site and typifies the local conditions. The initial foundation design for the heliostats was modified and approved by Sandia Laboratories. Heliostat tracking and pointing requirements limit the foundation tilt to 0.3 mrad under a 13.5 m/s (30 mph) wind. Load criteria for foundation design are summarized below for a 15.2 m/s (50 mph) uniform wind load.

- 1) Base bending moment $53,709$ N·m ($39,600$ lb_f -ft)
- 2) Base Shear $14,280$ N (3210 lb_f)
- 3) Torque $6,917$ N·m (5100 lb_f -ft)
- 4) Dead Load (axial) $26,690$ N (6000 lb_f)

Figure 4 shows the poured in-place foundations (1.2 m high x 3 m diameter tapered to 1.2 m) utilizing approximately 4 cubic yards of concrete.

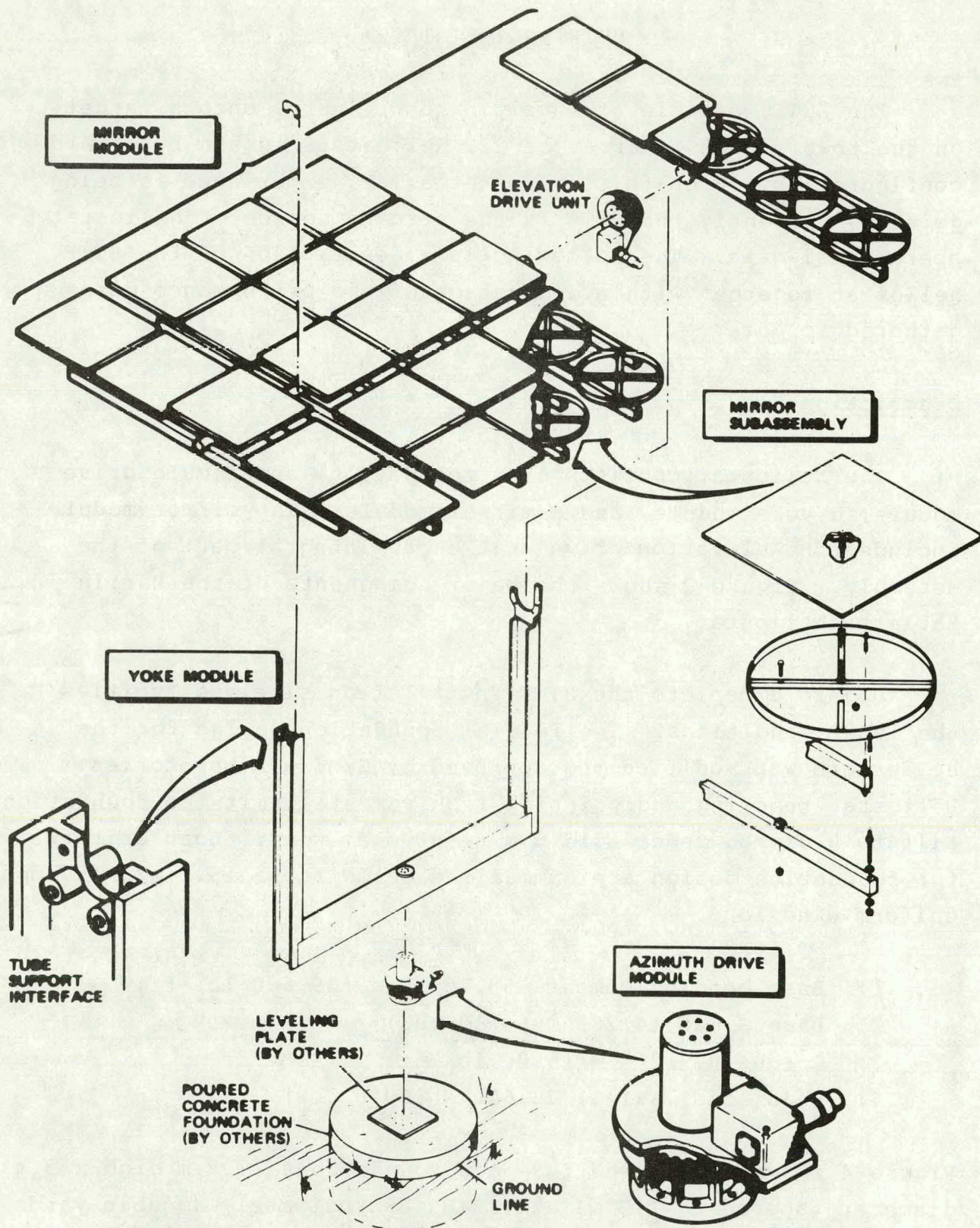

MARTIN- MARIETTA HELIOSTAT DESIGN FOR SOLAR THERMAL TEST FACILITY

FIGURE 2

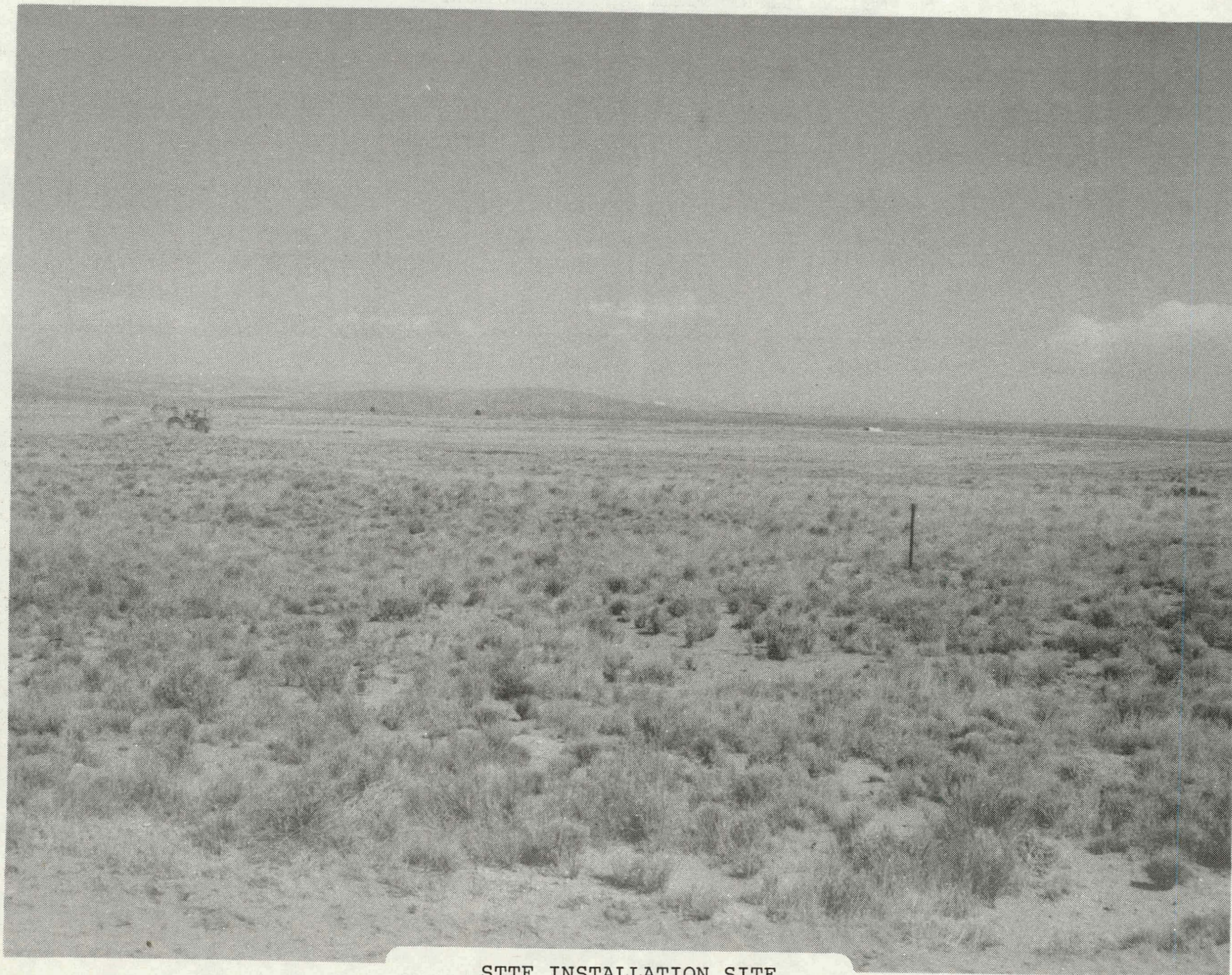

STTF INSTALLATION SITE

FIGURE 3



HELIOSTAT FOUNDATION INSTALLATION

FIGURE 4

The mirror module features an array of 25 mechanically distorted mirrors rigidly mounted in a 5 x 5 symmetrical pattern on gimbaled frames. Each 1.22 m x 1.22 m (4.0 ft x 4.0 ft) square mirror can be individually focused and aligned on its supporting framework. The entire mirror module provides 37.2 m² (400 ft²) of reflective surface and is capable of focusing an aberrated image of the sun on a fixed target. Figure 5 is a photograph of an STTF heliostat in the vertical or wash position.

An individual mirror assembly consists of a 1.2 m square mirror, support ring, stabilizer struts, and attachment accessories. The mirror consists of two sheets of 3.2 mm thick double strength float glass, one of which is silvered, and a polyvinyl butyral (PVB) laminate. The silvered sheet has a layer of copper deposited on the silver and is subsequently painted prior to lamination with the second sheet of float glass.

Each mirror requires a separate warping structure to achieve proper focusing. This technique is based on providing local stiffening in the form of a 1.17 m (46 in.) diameter steel hoop centered on the mirror and mounted on the back. This hoop is securely bonded to the back of the mirror with an elastic bonding agent that remains flexible over wide extremes in temperature. This hoop is reinforced by a planar strut assembly composed of two square tubes welded to the hoop. These tubes, which intersect at the hoop/mirror centerline to form a "cross" structure oriented along the mirror diagonals, provide pickup and attachment points for the mirror. Pads with integral threaded studs are bonded to the mirror at the centerline. The "cross" structure, in conjunction with the hoop stiffener, provides the reaction structure with which the mirror can be warped. The hoop frame becomes the edge support which allows the mirror to act as a simply supported plate free to rotate in circular symmetry. The warping forces are applied at the mirror centerline through the threaded stud fastener and jamb nuts and at the corners by corner-push studs.

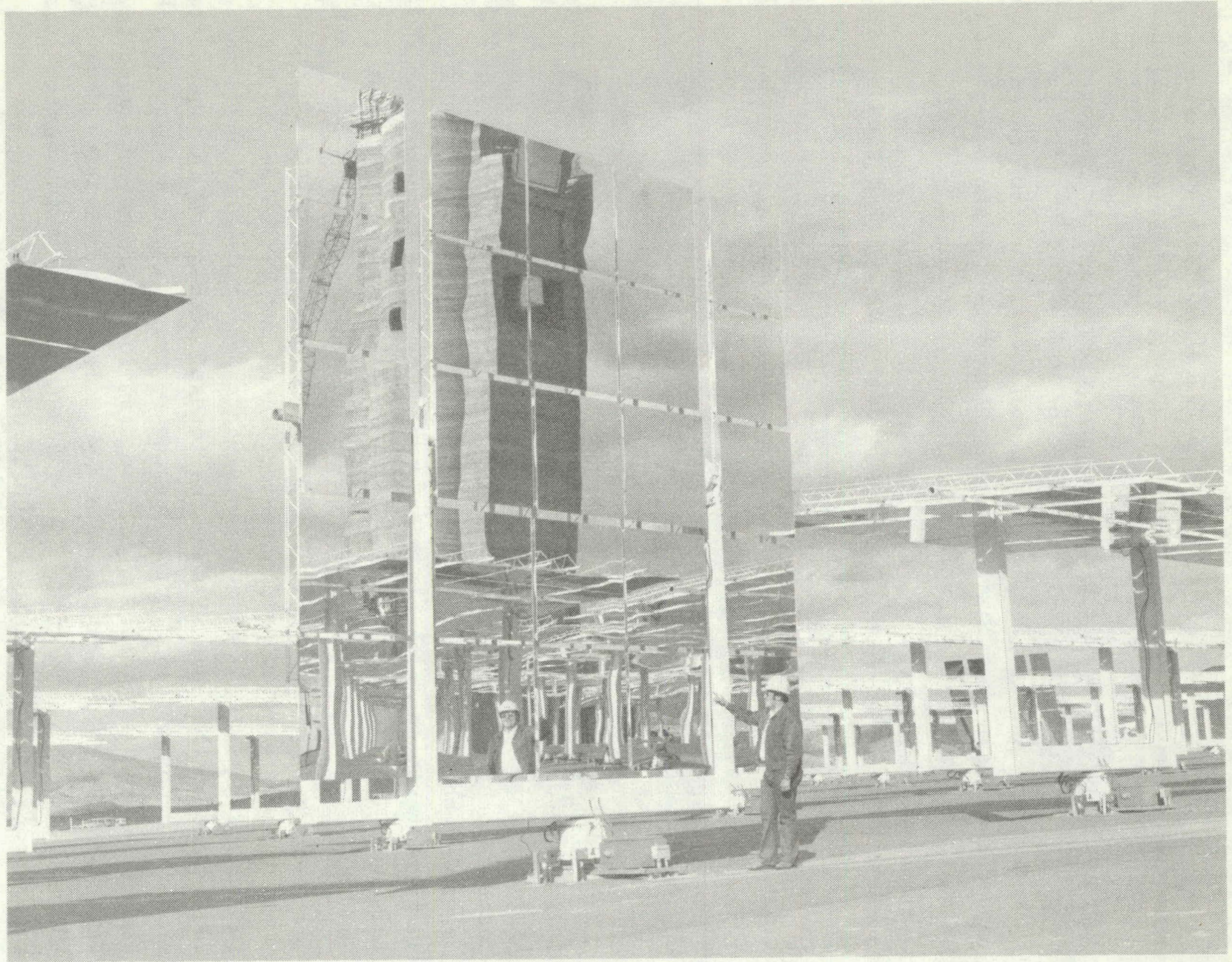

STTF HELIOSTAT IN VERTICAL POSITION

FIGURE 5

The azimuth drive module incorporates the azimuth drive mechanism (which includes an optical position encoder with 2^{13} address locations), azimuth bearing system, and a mounting flange for securing the entire heliostat assembly to the foundation. This module is the first component of the heliostat assembly to be installed in the field. The module is lowered over a ring of threaded anchor studs which are imbedded in the foundation. These studs protrude through a leveling plate that provides a stable mounting base. The yoke module is lowered by crane and attached to the azimuth drive module. The last item to be installed is the mirror module.

The heliostat drive systems are capable of maneuvering the heliostat as follows:

- 1) Azimuth, $\pm 2.40 \pm 0.44$ rad ($\pm 137.5 \pm 2.5$ deg)
- 2) Elevation, $04.71 \begin{smallmatrix} +0.00 \\ -0.09 \end{smallmatrix}$ rad ($-270 \begin{smallmatrix} +0 \\ -5 \end{smallmatrix}$ deg);
- 3) Azimuth slew rate, 13.4 rad/hr (755 deg/hr);
- 4) Azimuth tracking rate, 1.5 rad/hr (89 deg/hr);
- 5) Elevation slew rate, 17.82 rad/hr (1133 deg/hr);
- 6) Elevation tracking rate, 0.84 rad/hr (48 deg/hr).

The yoke module is the major structural element in the heliostat assembly and transfers wind-induced loads directly to the azimuth bearings. The vertical members of the yoke module are fabricated from wide flange sections welded to a horizontal member fabricated from square commercial tubing. At the center of the square tube section, corresponding to the azimuth center of rotation, a steel tube section is welded and provides for centering registration of the yoke module on the stub shaft of the azimuth drive module. After the yoke module has been lowered into position, centered, and properly seated on the azimuth module, the threaded studs are torqued to provide a rigid, self-centering connection to the azimuth drive unit.

The heliostat, in its normal tracking mode, is capable of continuously tracking the sun while maintaining pointing control to ± 1.5 mrad in wind velocities up to 13.5 m/s (30 mph). At higher velocities the heliostat will be returned to the "face-down" stowed position. Structurally, the heliostat is capable of surviving the effects of sustained wind velocities of 32 m/s (71.6 mph) with gusts up to 44.7 m/s (100 mph) without permanent deformation or mechanical degradation.

A Heliostat Control Electronics (HCE) is located on each heliostat and interfaces with the Heliostat Array Control (HAC) through a Heliostat Interface Module (HIM). The HCE performs all of the functions necessary to control the heliostats in the slew and track modes. The electronics contain interface isolation, data check circuits, position comparators, motor drivers, and output data formatting and processing logic. Figure 6 is a photograph of an open HCE mounted on a heliostat.

The HCE is housed in a sealed enclosure located on the lower heliostat yoke. The control electronics circuits are packaged on a separable subchassis together with power supplies mounted within its lower compartments. Two printed circuit board assemblies are (in the basic configuration) located along the top surface of the subchassis and interconnected by an internal wiring harness.

The housing is designed to prevent moisture, sand, or dust intrusion. Access to the electronics is provided by a removable cover secured with captive fasteners. Sealing washers are used in conjunction with the fasteners for a weatherproof seal.

The HCE has the capability for 16 operation modes. Currently 14 specific functions are defined. The following list categorizes the functions into 6 classes:

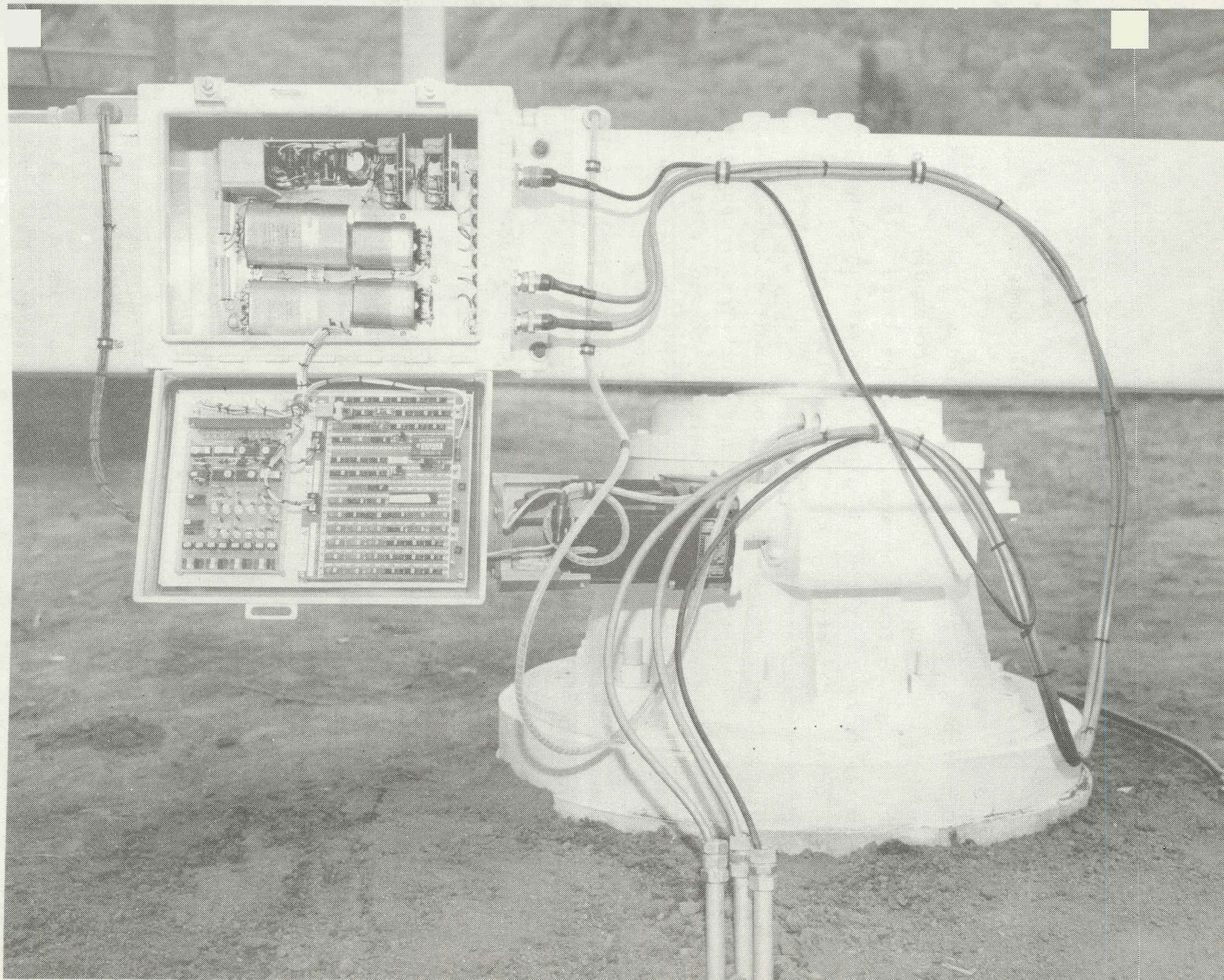

HELIOSTAT CONTROL ELECTRONICS UNIT

FIGURE 6

- 1) Status - HCE status returned to HAC;
- 2) Clear - All HCE mode registers are cleared and all motors stopped;
- 3) Coarse track - Slew motor of specified axis is activated in closed-loop operation (one azimuth command, one elevation command);
- 4) Fine-track - Track motor of specified axis is activated (one azimuth command, one elevation command);
- 5) Direct stow - Four commands allow specified axis track motor to be activated in either clockwise or counter-clockwise direction. Only limit switches or clear command will turn the motor off;
- 6) Direct slew - Four commands allow specified axis slew motors to be activated in either clockwise or counter-clockwise direction. Only limit switches or clear command will turn the motor off.

To assure safe operation of the heliostats for both personnel and equipment, the following features are incorporated in the design:

- 1) Pointing limits - HAC control programs preclude pointing the reflected beam of any heliostat toward any position located out of a preselected region.
- 2) Limit switches - Limit switches are located at each end of azimuth and elevation travel of the heliostat axes. These are provided to avoid twisting ground straps and associated cabling.
- 3) Manual Control Box - Local control of the heliostat is possible only when this box is connected to the HCE unit. When it is connected, HAC control of the heliostat can be locked out.

Focus and Alignment

Focusing of STTF heliostat facets is accomplished by first dividing the heliostat field into 7 focusing zones. The facets

are focused during assembly to correspond to the focal zone in which they will be installed.

The alignment subsystem consists of a laser collimator (L/C) (shown in Figure 7), control and monitoring equipment at the heliostat, and a display target.

The beam from the L/C is approximately the size of the 1.2 m square mirror facet. The control system is used to position the heliostat so that the laser reflection from the center facet is displayed on the center of the target. The heliostat position is noted and encoder biases are recorded. For the remaining 24 facets, the heliostat is oriented and the L/C is repositioned by the computer to form the proper geometry. Each facet is subsequently aligned to reflect the laser beam to the target center. Figure 8 shows this alignment activity.

Control

The heliostat pointing commands from a preprogrammed test sequence or from the facility operator are analyzed by the Master Control System (MCS) and distributed to the heliostats for execution. Heliostat Array Controllers (HAC) communicate with up to 128 heliostats in their jurisdiction. Each HAC sends MCS generated commands, and HAC generated azimuth and elevation pointing information to its four associated Heliostat Interface Modules (HIM) to be transmitted to the appropriate heliostats. Each heliostat receives an aiming vector update once every second and responds with its own status. The HACs also process alarm messages such as tracking or communication errors.

The commands and data transmitted to the individual heliostats are received and executed by the Heliostat Control Electronics (HCE). The HCE provides power to the drive motors until the position

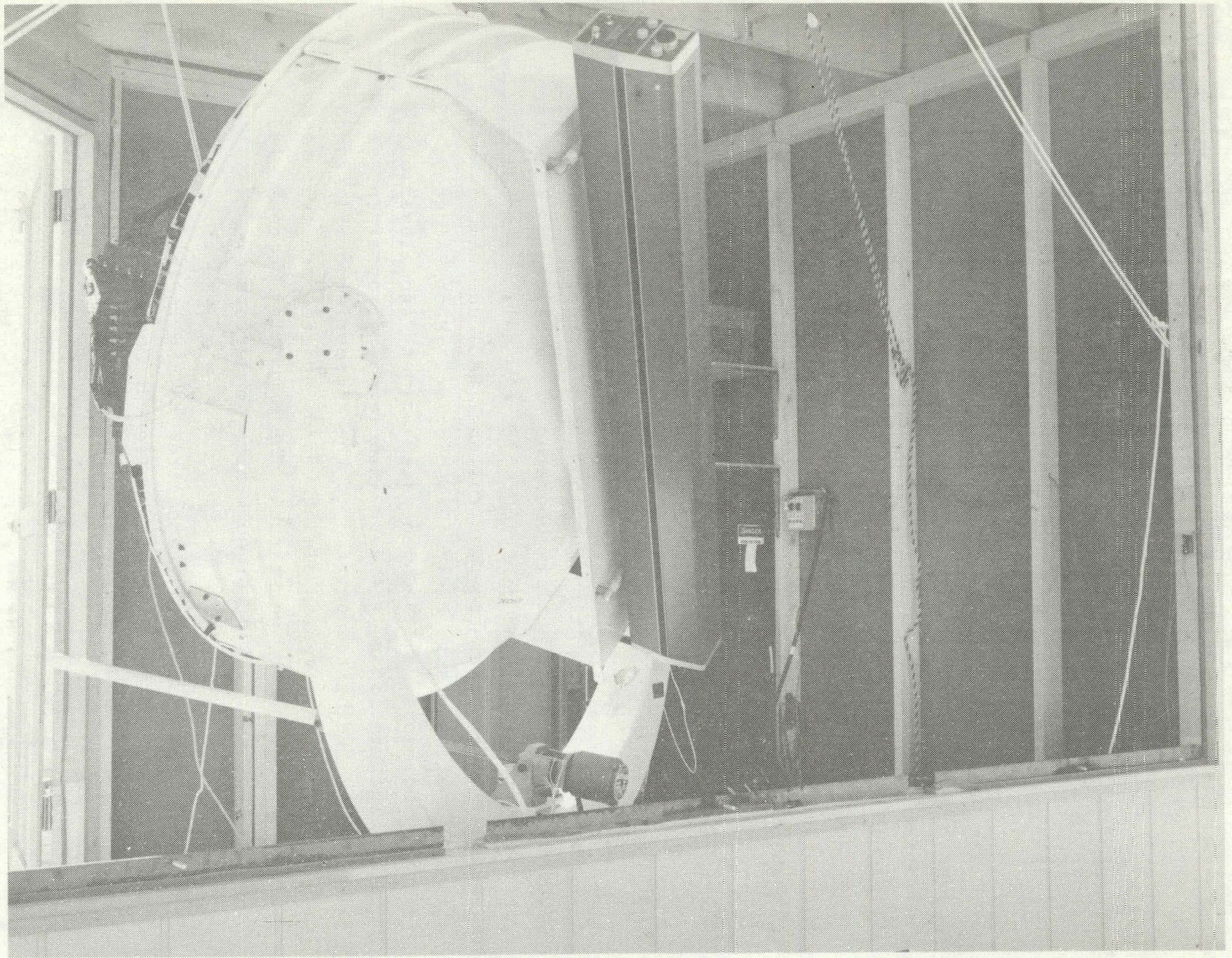

STTF LASER COLLIMATOR
ALIGNMENT SYSTEM

FIGURE 7

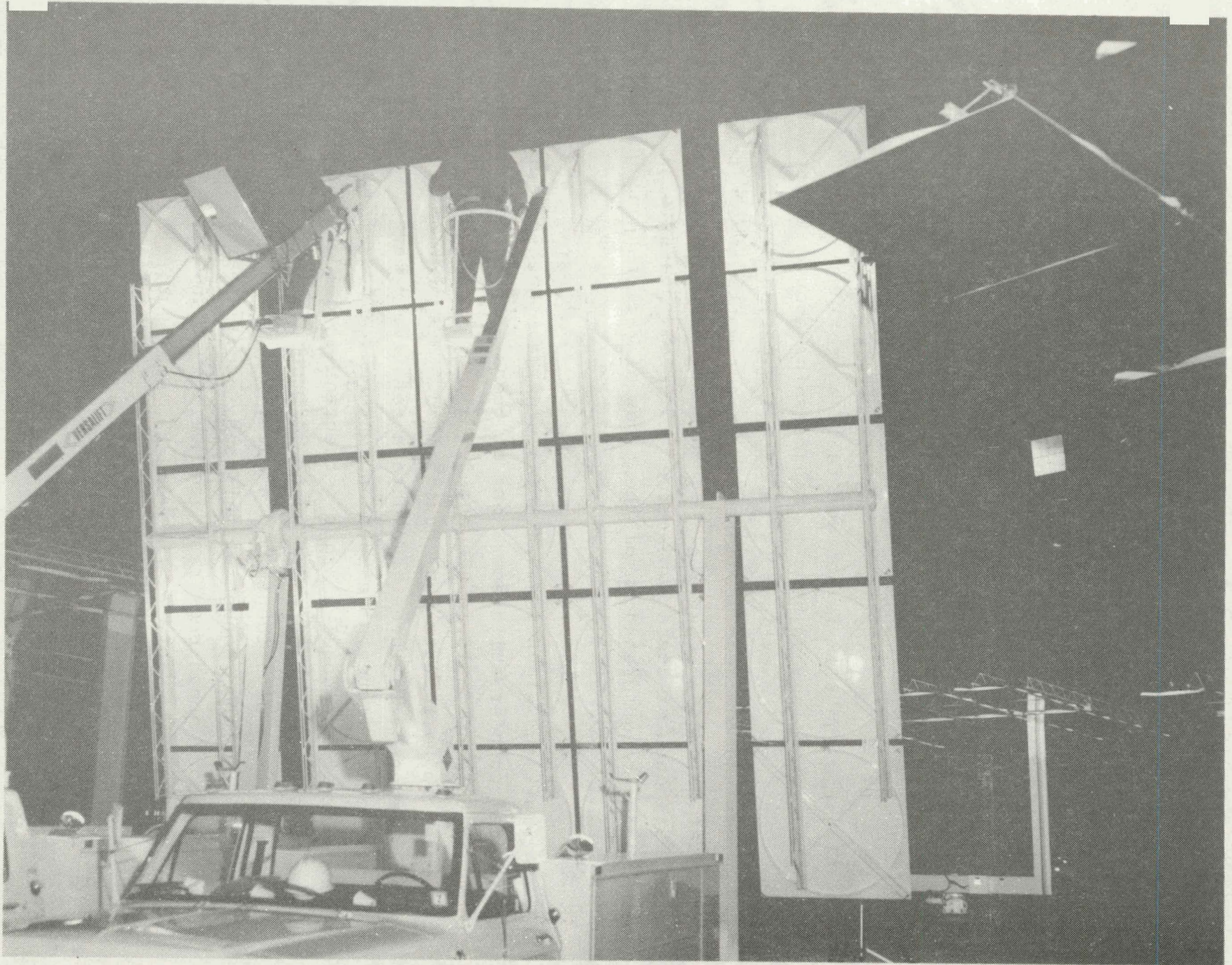

STTF ALIGNMENT ACTIVITY

FIGURE 8

encoders indicate that the appropriate heliostat attitude has been attained. The HCE and heliostat motors then await the next command.

Figure 9 shows the facility operator console with video displays. Figure 10 shows a closeup of the heliostat field status display with the information available to the facility operator.

HELIOSTAT PERFORMANCE

Maintenance and Repair

Although the STTF is not yet fully operational, nighttime heliostat operation has been in progress for about 8 months. The purpose of these operations is to obtain experience with failure mechanisms and to incur any inherent infant mortality in the heliostat hardware. Figure 11 presents a summary of the cumulative heliostat-hours of operation, percent of field operational with time, and a rough breakdown of the types of failures encountered thus far.

Azimuth and elevation drive failures have been primarily related to optical encoder failures. Most of these encoder failures are due to an adjustment fault in the encoder alignment and have been corrected on heliostats that have failed. HCE problems involve mainly component failures. To date a relatively large number of intermittent failures have been encountered. These failures are observed to be seasonal (larger percentage in colder months) which suggests some temperature dependence. Other failure causes include items that have been identified as design deficiencies (i.e., inadequate sealing, connector failures, etc.) and serve to give input to those areas requiring engineering attention. In particular, moisture and the resulting rust on the metal surfaces, has been found in almost all of the heliostats which have failed.



STTF CONTROL ROOM
OPERATOR CONSOLE

FIGURE 9

1977 DAY 322 12:51.5 NKT.



ZONES A & B.
394 HELIOSTATS.

CHDS = HU HD SB DT HS OS ES /M TERM & ??
EXIT PAUSE & CONTINUE AFFECT SCHED OPERATION

CHD FORMAT = CHD;HEL(S)E;PARAMETERS; "RETURN"
COMMAND

SHUTDOWN FORMAT = ES # "RETURN" (# = 0-3)

COMMAND IN ERROR IS:

SELECTION VIA CRG 1 & ENTER.

CLEAR COM AREA
STATUS LEGEND
HELIOSTAT INFO
DIN HEL STATUS

HEAT REJ. SW
WARNING MODE.

- X = NO POWER
- . = Deselected
- ← = STON NODE
- ↑ = UP NODE
- ↓ = DOWN NODE
- S = STANDBY MODE
- T = ON-TARGET MODE

HELIOSTAT IN TRANSIT

WITH OFF-SET

ALARM COND. CAUTION

ALARM COND. WARNING

HELIOSTAT FIELD DISPLAY MONITOR

FIGURE 10

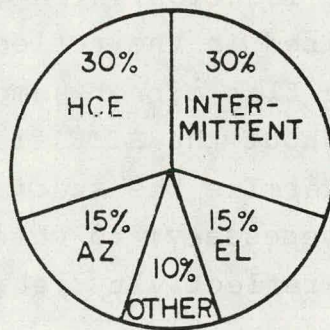
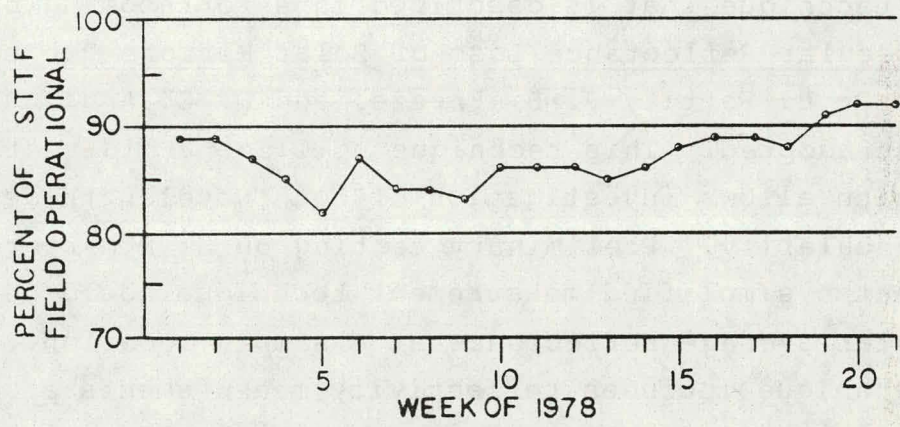
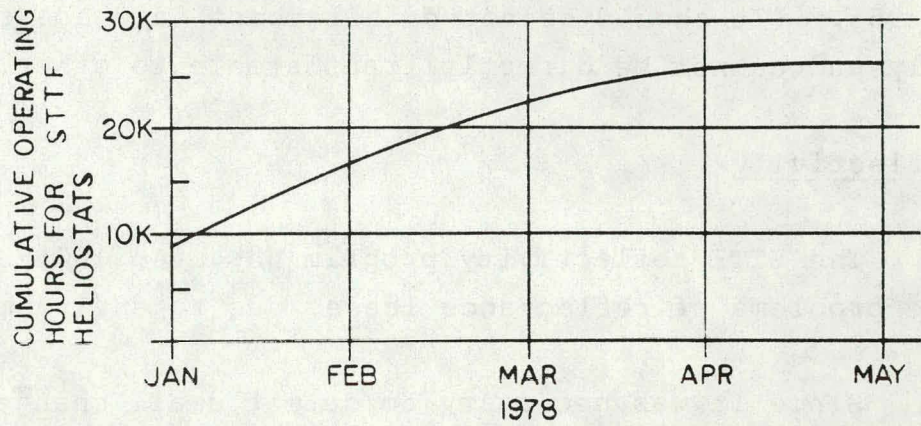

HELIOSTAT REPAIR

STTF HELIOSTAT OPERATION AND REPAIR

FIGURE 11

It is anticipated that correction of these and similar problems and a continued decrease in failures due to infant mortality will improve the field operational status in the future to 95%. (It should be noted that these data are for STTF heliostats only and cannot be directly translatable to other type heliostats.)

Reflectivity

The STTF reflectivity program has been initiated to address the problems of reflectance losses due to environmental influences.

Since it was necessary to detect small changes in reflectivity, an accurate technique for reflectivity measurements was required. A technique that is described in a forthcoming publication entitled Specular Reflectance Loss of Solar Mirrors Due to Dust Accumulation by R. B. Pettit, J. B. Freeze, and D. E. Arvizu of Sandia Laboratories was adopted. This technique utilizes a bidirectional reflectometer which allows investigation of both wavelength dependence and surface specularity. Preliminary testing on STTF mirror samples indicated that a simplified measurement technique could be used to characterize solar average reflectance at a sample location. This measurement technique includes reflectivity measurements at only 1 or 2 wavelengths per sample location which greatly reduces the number of measurements required in the reflectivity program. This program includes 54 6-inch flat mirror samples mounted on heliostats and distributed throughout the STTF field, see Figure 12. Work is progressing to determine the statistical requirements (number of random locations necessary) to characterize an entire mirror surface based on measured reflectivity variances and a specific source beam diameter.

The parameters under investigation include reflectivity degradation as a function of time, field location, and stowage orientation; influences on reflectivity by natural cleaning phenomena, cleaning agents, and wash/rinse procedures.

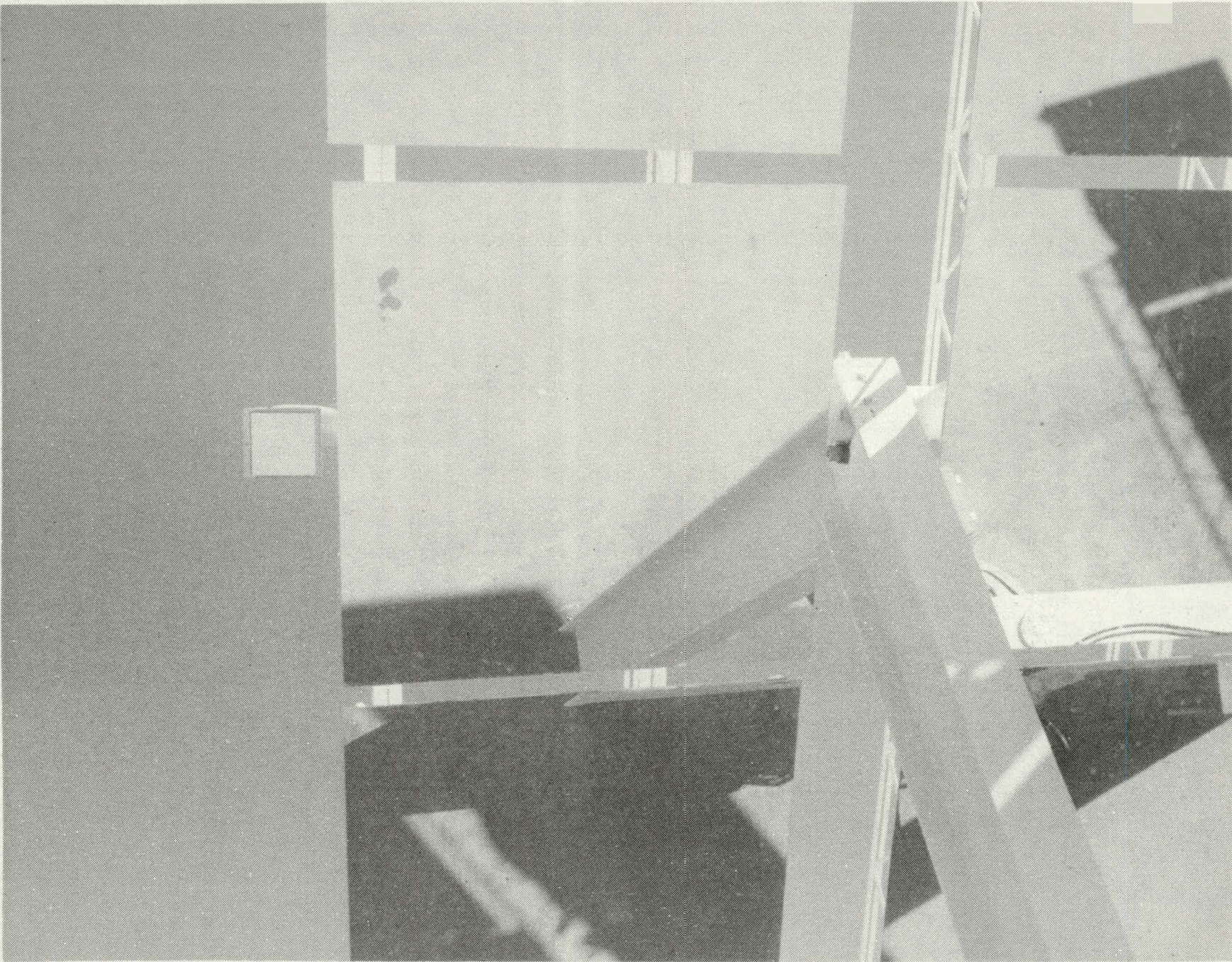

INSTRUMENTATION MIRROR MOUNTED
ON HELIOSTAT FRAME

FIGURE 12

There is a vast amount of work still necessary to develop optimum cleaning procedures. However, in the interest of acquiring data and developing experience with a specific technique, it was decided to commit, at least initially, to a high pressure water/detergent application technique. This decision was based on testing done at the STTF where mirror samples were cleaned using a 300 psi and 3 GPM water stream with several detergents and solvents. This testing indicated that with a high pressure application technique it was possible to recover a high percentage (80 - 90%) of the reflectance loss due to short term environmental influences. During a recent trip to Tritan Corporation of Houston, Texas (contracted to supply STTF with a mirror washing vehicle) some dirty mirror samples were subjected to 500, 1500, and 10,000 psi tap water streams. Reflectivity tests showed that there were no significant differences in recovered losses with these three pressures. All recovered about 95% of the original 0.81 average solar reflectance.

Figure 13 shows the influence on average solar reflectance of stowage orientation with time. These data show that a "face-down" stowage is not as influenced by environmental conditions as the "face-south" or "face-up" stowage orientation. It should be noted that in this test the mirror samples remained in their respective stowage orientation over the entire test period.

Beam Characterization System

As part of the STTF heliostat evaluation program a Beam Characterization System (BCS) is under development. Several alternatives have been and continue to be investigated. Work that is underway specifically addresses evaluation of the 10MW_e Pilot Plant heliostat prototypes.

As a measurement of beam "quality", the BCS will verify that a heliostat can concentrate reflected energy within a specified

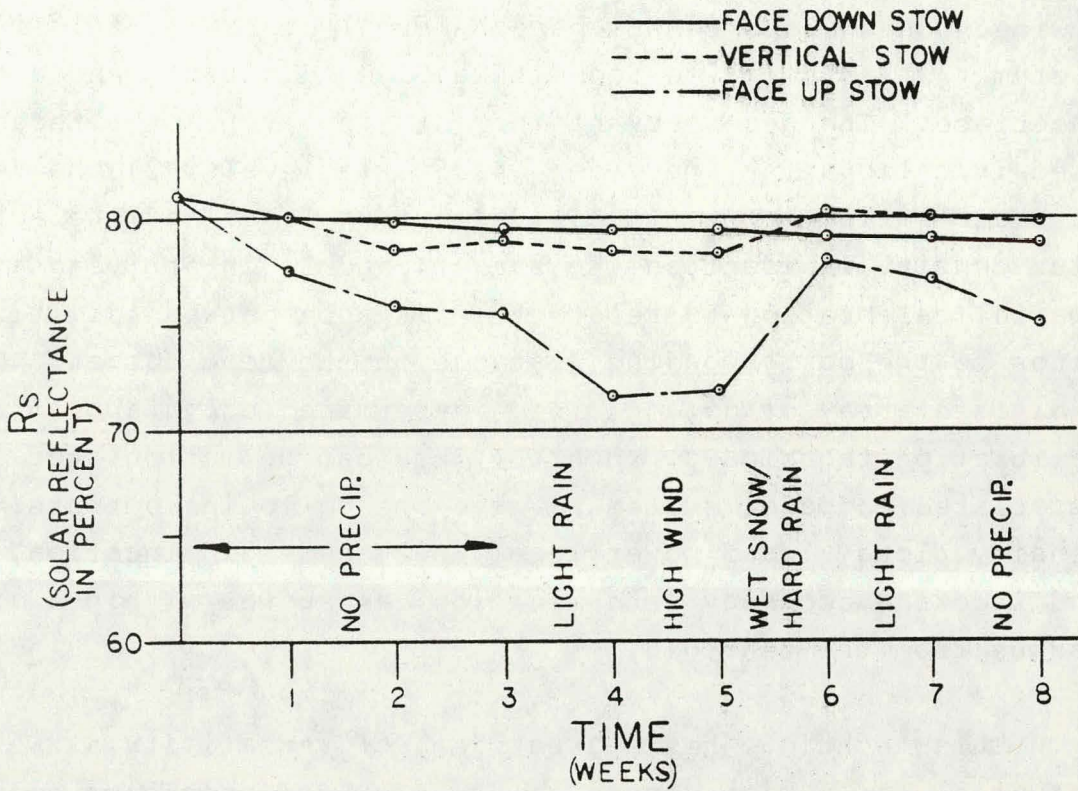

REFLECTIVITY VS. TIME FOR
DIFFERENT STORAGE ORIENTATIONS
IN STTF HELIOSTAT FIELD

FIGURE 13

area. This will be accomplished by first calculating the theoretical beam shape for the given geometry and test conditions using the Sandia provided HELIOS program. A 1.4 mrad fringe will be added to this theoretical beam shape and then a comparison to the beam shape measured by the BCS will be made.

The proposed BCS technique is basically a refined version of a widely used video camera based thermal or radiometric imaging system that is complimented with a video digitizer and a computer interface. The necessary refinements involve 1) the techniques used in calibrating the video gray scale levels, 2) the determination of the relation between the video output level and the actual heat flux density incident on the target, and 3) in arriving at a spatial calibration to relate the distance between digitized scan lines to the corresponding distance on the beam target. Once the digitized array of data has been determined using appropriate calibration techniques, then the data can be manipulated in an associated computer system to give the following outputs: 3-D flux density plots, total power level, beam centroid location, pointing and tracking accuracy determination, and power within a given radius from the centroid.

This technique has a great deal of versatility as well as potential for a high degree of accuracy and precision. Advantages include a wide range of target intensity measuring capability (accomplished by adding appropriate neutral density filters to the camera), possible use of the system as a heliostat alignment tool, and possible use for infrared scanning of receivers as a check for hot spots.

A second technique that is under study is a photographic technique that utilizes appropriately selected film that can subsequently be digitized in a manner similar to the video generated data using a photodensitometer. A limitation of this technique is its inability to process data in real time.

A third alternative for a BCS involves the use of circular foil heat flux gages. Since the cost, calibration, and maintenance of a 2-dimensional array of gages is untenable, an instrumented sweeping bar technique has been investigated. To demonstrate this technique the STTF has developed a Cal-bar system designed to measure single heliostat flux density profiles. The measurement hardware requires the use of a ground target and thus introduces constraints in the heliostat orientations to be tested.

The measurement procedure involves either sweeping the instrumented bar horizontally across a beam projected onto a ground target or sweeping the beam across a stationary bar. The instrumented bar is approximately 5 meters in length and can accommodate 64 gages spaced at 7.6 cm (3 in.) intervals. The bar is water cooled to keep the gages within their specified operating range during measurements.

The heat flux gages used are the circular foil type covered with a quartz window. Their ranges are 0.1 w/cm^2 and 0.2 w/cm^2 full scale with linear response over the entire spectral and thermal range and they have a nominal response time of 250 milliseconds.

Beam Measurements

Several tests utilizing the Cal-bar have been conducted on facility heliostats. In these tests, the heliostat beams were swept across the bar to eliminate tracking influences. Figure 14 shows the Cal-bar in position with a heliostat beam just prior to sweep. Figure 15 presents some data from this device in the form of a typical heliostat beam contour plot.

A series of 6 tests was run. Three heliostats, selected along the northeast edge of the field, were measured both with alignment conditions matched and mismatched to the run conditions. (i.e., aligned for day 344 measured on day 56 and aligned for day 70

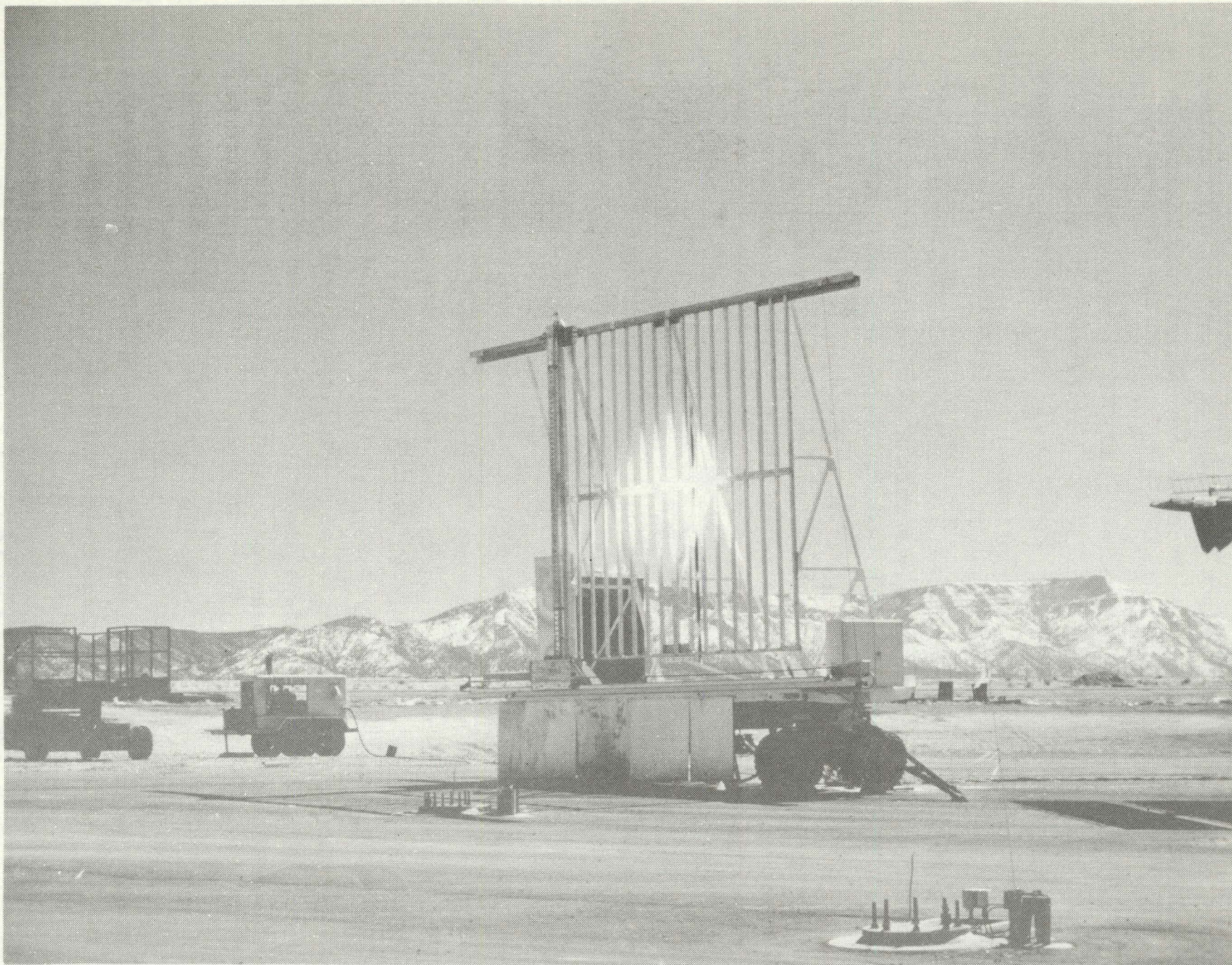

CAL-BAR BEAM MEASUREMENT SYSTEM

FIGURE 14

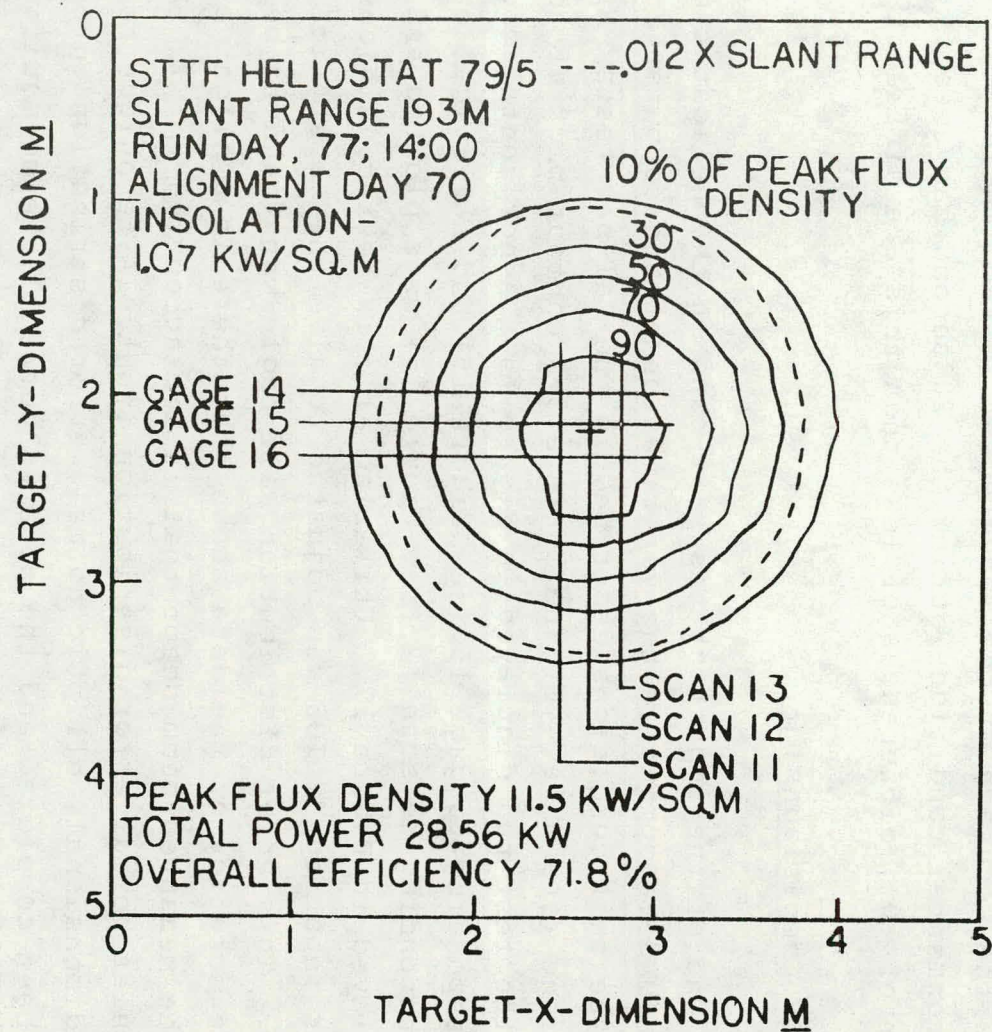

HELIOSTAT CONTOUR PLOT

FIGURE 15

measured on day 77.) Improvement of reflected energy into a specified area, primarily a 12 mr circle, was detected to be only a few percent from the matched alignment conditions to the mismatched alignment conditions. One heliostat was measured before and after cleaning. No difference was detected, however a heavy thunderstorm had "naturally cleaned" the test heliostats (which were stowed in the vertical wash position) prior to testing the uncleaned condition. Since the accuracy of the measurement system (including the changing environmental conditions during the 20 second bar sweep) is on the order of 10%, differences of less than this are difficult to quantify.

HELIOS Comparisons

One of the important tasks at hand in the heliostat evaluation program development is the verification of the computer code HELIOS. For the test conditions described in the Cal-bar tests, HELIOS predictions were made. Figure 16 is a 3-D contour plot of the prediction for the test run displayed in Figure 15. A horizontal cross section corresponding to gage 15 (see Figure 15) and a vertical cross section corresponding to scan 12 (see Figure 15) were plotted and are displayed in Figure 17. Utilizing all six test conditions, the error input to HELIOS was adjusted to give the "best fit" on all data. This error distribution half angle was found to be 2 mrad. Close scrutiny of the data shows that there is a slight ellipticity of the measured beam shape that is not accounted for in the HELIOS circular normal error distribution input. A technique for specifying a 2-dimensional, elliptic normal, error distribution into HELIOS has been completed and the code is currently being modified to include this capability. (Again, the accuracy of the measurements will only allow qualitative statements about beam ellipticity and handling of 2-dimensional error distribution inputs into HELIOS to be made.)

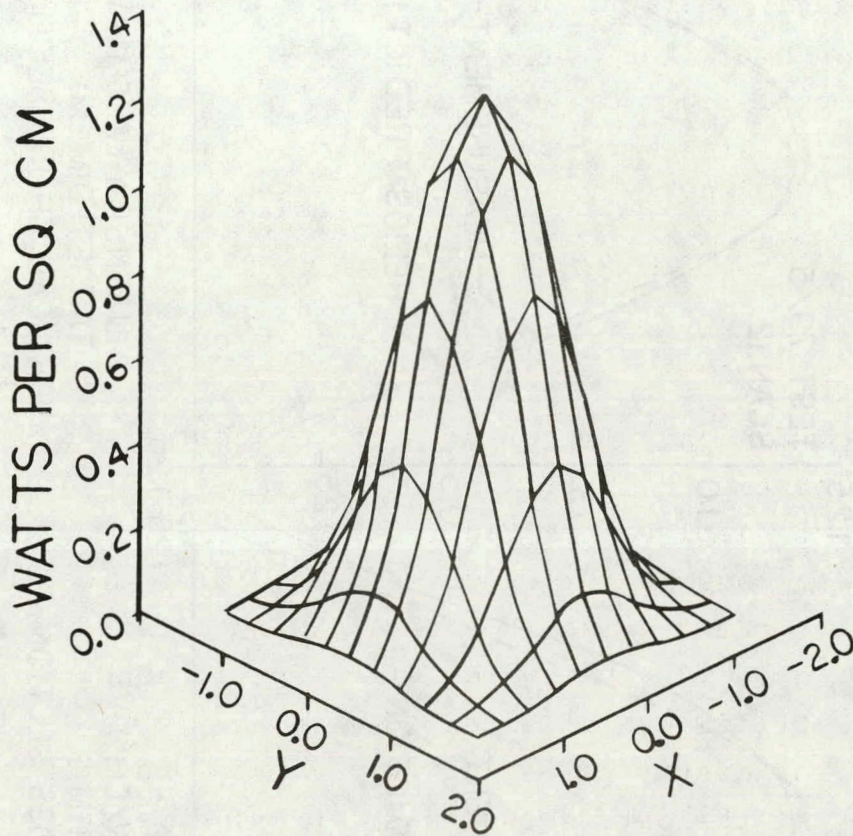

ALIGNED FOR DAY 70
DAY = 77.00
TIME = 2.0

HELIOS PREDICTION FOR
TEST CONDITIONS
OF HELIOSTAT 79/5

FIGURE 16

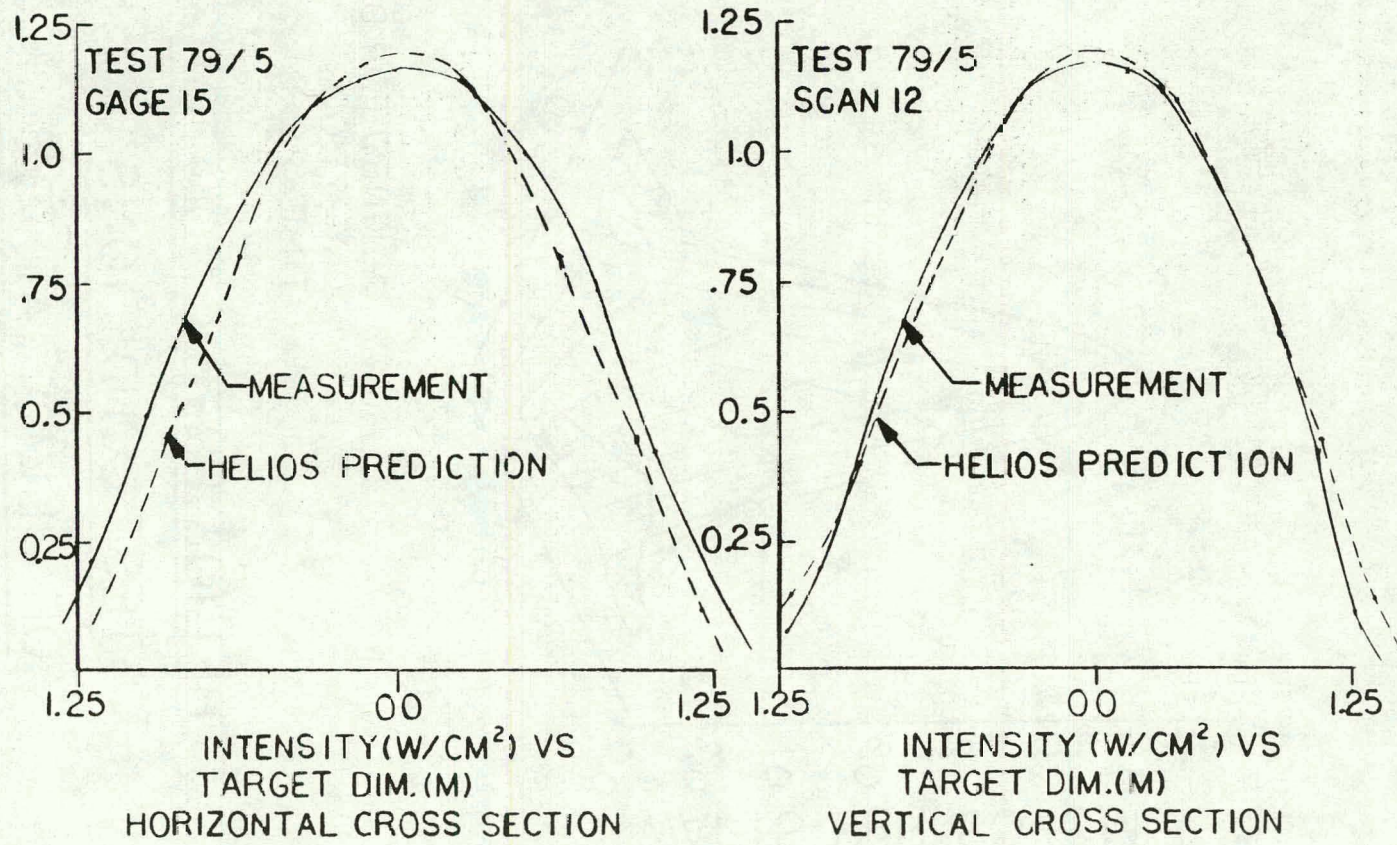

MEASURED VS. PREDICTED BEAM SHAPE

FIGURE 17

SUMMARY

The importance of the heliostat subsystem in power plant application has made it necessary to devote much attention to heliostat engineering. The intended use of a heliostat array figures as an important input to its design requirements. "Quality and performance" must be defined with respect to the subsystem requirements.

The STTF is currently one of the largest sources of heliostat performance data. Operational experience is being gained that will develop expertise in this relatively new field. Failure mechanisms are beginning to be identified and this input to new designs is judged to be significant in improving maintenance and repair intervals.

In addition, the heliostat evaluation program that is currently underway has promoted development of a versatile Beam Characterization System that will provide information concerning heliostat "quality and performance." The use of this measurement tool, together with the computer code HELIOS will establish a good basis for heliostat evaluation of not only the DOE/Utility sponsored 10MW_e Pilot Plant prototypes, but also many new and advanced heliostat, or concentrator, subsystems.

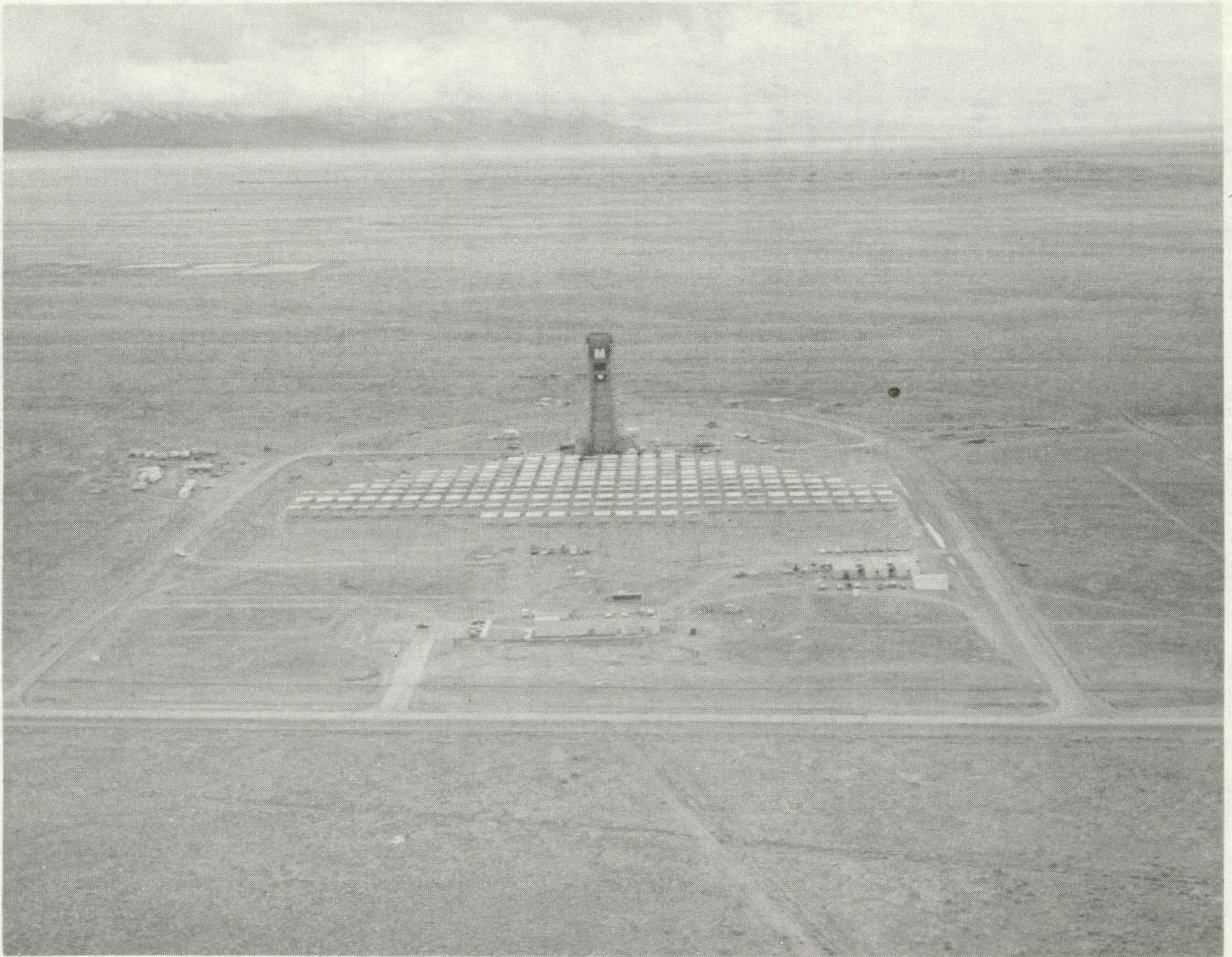

SOLAR THERMAL TEST FACILITY

References

1. Eason, E. D., "A Heliostat Cost/Performance Model for Trade-Off Studies", Division 8122 Memo, Sandia Laboratories, Feb. 22, 1978.
2. Mavis, C. L., "Technical Evaluation of Responses to Request for Quotation D3-3731 for Solar Test Facility Heliostat Array and Control System", Division 8184 Memo, Sandia Laboratories, Dec. 31, 1975.
3. Biggs, F., Vittitoe, C. N., "On the Evaluation of Heliostats", Division 5231 Memo, Sandia Laboratories, Dec. 5, 1977.
4. "Solar Thermal Test Facility Experiment Manual", Division 5713, Sandia Laboratories, October 1977, SAND77-1173.
5. Vittitoe, C. N., Biggs, F., Lighthill, R. E., "HELIOS: A Computer Program for Modeling the Solar Thermal Test Facility - A Users Guide", SAND76-0346, March 1977.
6. Martin Marietta, "Technical Proposal for Heliostat Array and Control System for 5MW Solar Thermal Test Facility", December 1975.

THIS PAGE INTENTIONALLY LEFT BLANK

CONCENTRATORS FOR PHOTOVOLTAICS

by

Charles E. Backus and Byard D. Wood
College of Engineering and Applied Sciences
Arizona State University
Tempe, AZ 85281

Essentially all of the more than 1000 space satellites that have been launched utilize photovoltaic power systems. Photovoltaics has proven itself as a highly reliable, predictable system in these applications. They are also the lowest cost systems compared with the other alternatives for space power systems. For terrestrial applications, however, photovoltaic power systems are usually very expensive compared to terrestrial alternatives. The most expensive part of these power systems is in the solar cells used which are the actual direct converters of sunlight to electricity. It would seem that cheaper cost per unit area concentration devices could be used in conjunction with the more expensive cells to produce lower cost electricity.

During the 1960's before the present blossoming of solar activities, a number of studies were conducted to investigate concentration photovoltaics (1-6). Most of this activity was due to E. L. Ralph of Spectrolab, Inc. In 1963 a joint Spectrolab/University of Wisconsin program produced a small solar cell concentration system. A 5X4 cm array of 8 series-connected cells was mounted on a copper tubing substrate. This array was tested outdoors in sunlight using a 6' square heliostat and a 4' diameter parabolic reflector shell. The individual cells in this array had quite good efficiencies and showed an optimum efficiency of about 12 1/2% at about 3-5 suns concentration. The eight cell array was used to operate a small water pump and produced 1.1 amps at 3 volts with a solar insolation of about 55 suns. A second generation system utilizing an array of 18 series-connected cells which were each 1X2 cm, was capable of producing 50 watts at a cell of 25°F at about 280 suns concentration. Although these early studies were of very limited scope and utilized solar cells of crude design they nevertheless provided important information on critical design parameters. Projections were made of cost reductions down to about \$10/peak watt for concentrated photovoltaic systems compared with over \$100/peak watt for the flat plate array systems available at that time.

A more extensive investigation was initiated in January 1974 as a joint investigation by Arizona State University and Spectrolab, Inc. (7). The purpose of this investigation was to determine how to design cells for high

concentration and to identify the limits of the cell or any other of the components of the system. At that time it was generally thought that increasing the sunlight intensity significantly above one sun on silicon cells would seriously degrade their performance. Also the technical problem of heat removal had not been seriously addressed. The excess heat generated when sunlight is concentrated on cells will tend to cause the cell temperature to increase which decreases the electrical output of the cell. Either this energy must be removed from the cell and dissipated into the atmosphere or utilized for some low temperature thermal applications.

The investigations at ASU on concentration photovoltaic systems has been continuously funded since January 1974 through sponsorship by NSF, ERDA, and now DOE. The encouraging results that have come from this and other studies have led to a fairly substantial part of the national photovoltaic program being devoted to photovoltaic concentration systems. Sandia Laboratories in Albuquerque, NM has the program responsibility for photovoltaic concentration systems in the national program for DOE.

The Uniqueness and Principles of Photovoltaics

There are several major differences in the considerations one must make when designing photovoltaic concentrator systems as opposed to solar-thermal concentration systems. The two major concerns are in heat retention in the receiver and sensitivity of the solar cell response to the spectral content of sunlight. In a thermal concentration system one is interested in obtaining higher temperatures than flat plate collectors and one would like to collect the fluid at as high a temperature as possible without significant sacrificing of efficiency. However in photovoltaic receivers it is desired to keep the temperature as low as possible for maximum electrical output. The characteristics of solar cells are such that the efficiency essentially linearly decreases with increasing temperatures. Of course if one would wish to utilize the thermal energy removed from the cells for some useful purpose then one must make a trade off of the usefulness of the rejected fluid temperature and the electrical output of the cells. The second major difference in photovoltaic concentration systems concerns the spectral content of the energy. Whereas a good flat black absorber will absorb thermal energy equally efficiently for all wavelengths, photovoltaic devices are very sensitive in their spectral response characteristics. In order to appreciate the dependence of solar cells on spectral content, and how the design of the

collector may influence spectral content, one must understand the basic principles governing photovoltaic devices. The following tutorial discussion on the basics of photovoltaics is essentially that given in Ref. 8.

The photovoltaic effect is defined as the generation of an electromotive force as result of the absorption of ionizing radiation. Energy conversion devices which are used to convert sunlight to electricity by use of the photovoltaic effect are called solar cells. The photovoltaic effect can be observed in a variety of materials, but the materials that have shown the best performance in sunlight are the semiconductors. The material which has been used for the vast majority of solar cells to date is the semiconductor silicon. When photons from the sun are absorbed in the semiconductor they create free electrons at higher energies than the electrons which provide the bonding in the base crystal. Once these free electrons are created there must be an electric field to induce these higher energy electrons to flow out of the semiconductor to do useful work. The electric field in most solar cells is provided by junctions of materials which have different electrical properties. These two materials may be the same base material, such as silicon, but treated in different ways such that the electrical properties are different from one side of the silicon to the other.

Electrons in isolated atoms can exist only at discrete or quantized energy levels. Furthermore, the Pauli exclusion principle limits the number of electrons that can exist at any allowed energy level. When atoms are brought close together, as in a crystal, so that their potential functions overlap, the exclusion principle still holds and the energy level must split and form clusters of acceptable energy levels. These clusters, or bands, consist of a large number of closely packed discrete energy levels. There are as many levels in the bands as there are atoms in the crystal and as many bands as there are energy levels in an isolated atom of that material. Since there may be 10^{22} atoms in a crystal, the allowed energy levels within the bands can be considered as continuous. The energy of the electrons in the material can be represented on a one-dimensional energy diagram (Fig. 1) showing various ranges of energies that electrons are allowed to have, and the ranges of energies in between the allowed bands where electrons are forbidden to exist. The energy widths of these allowed and forbidden bands depend on the particular material and its atomic spacing.

The number of electrons in a material is a small percentage of the allowed

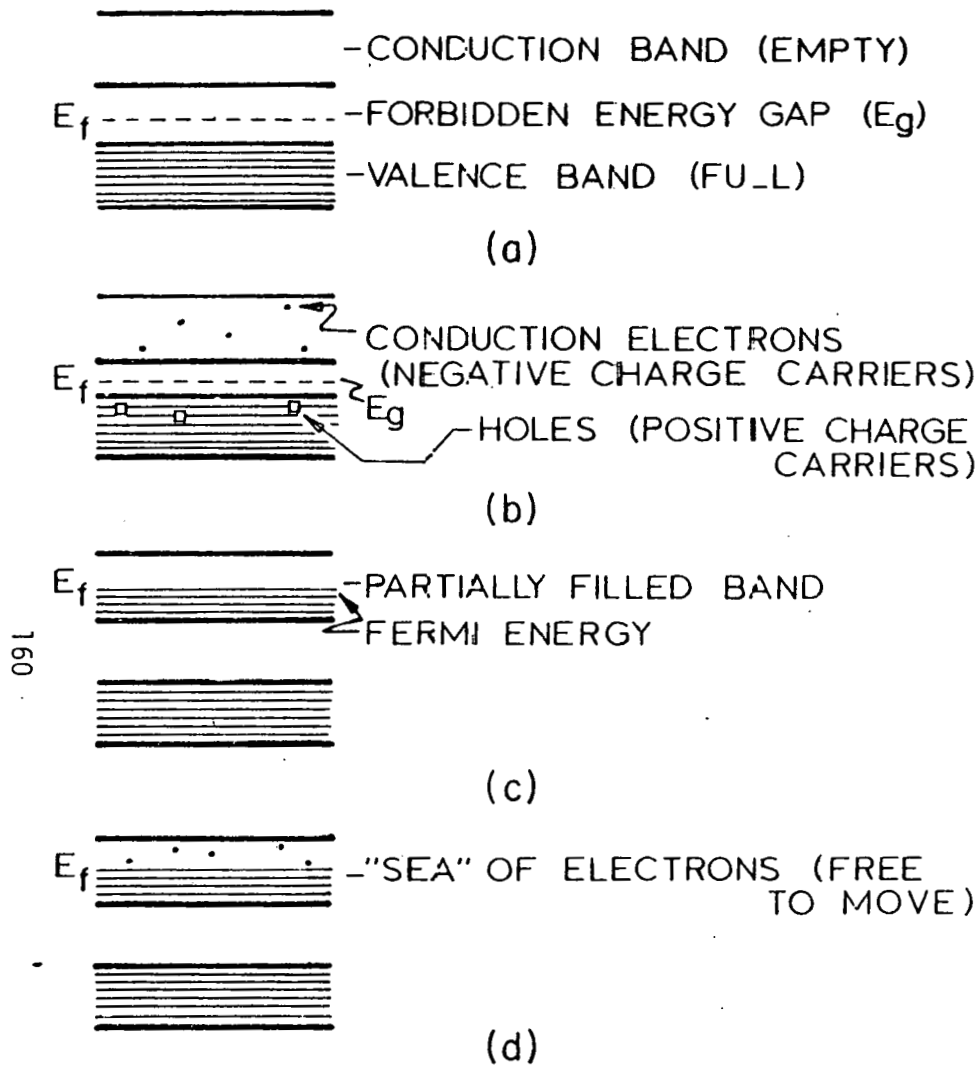

Fig. 1. One-dimensional energy band diagrams for different types of materials. (a) Intrinsic insulator or semiconductor at 0°K ; (b) intrinsic semiconductor at $T > 0^\circ\text{K}$; (c) metal or good conductor at 0°K ; (d) conductor at $T > 0^\circ\text{K}$.

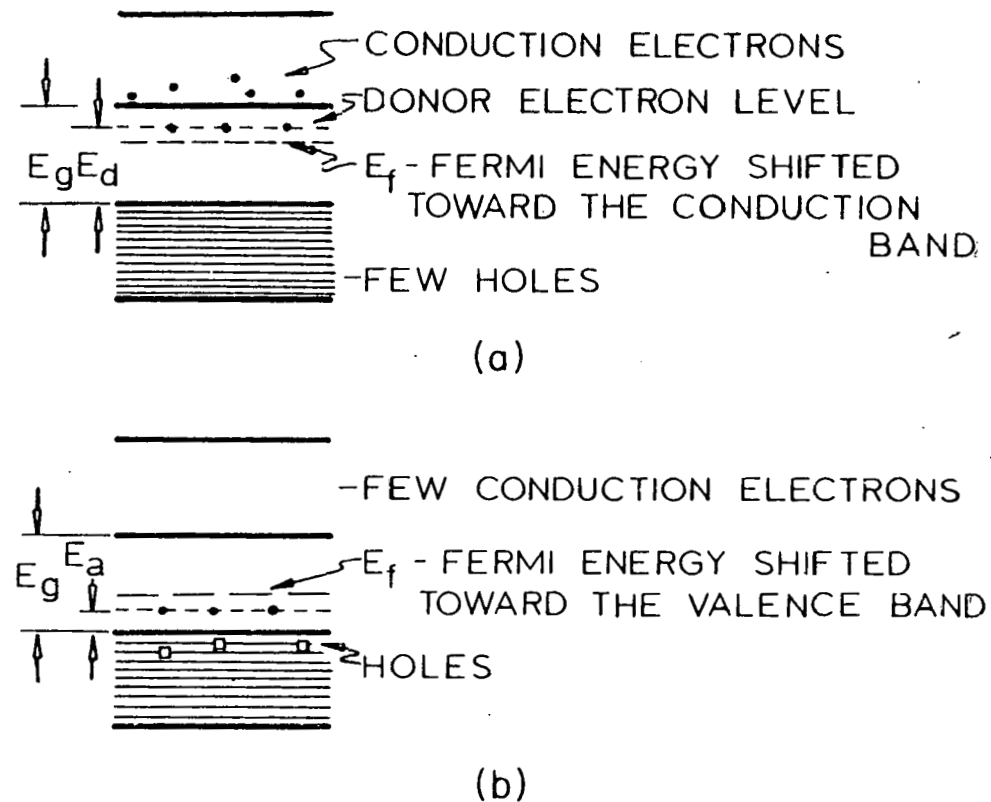

Fig. 2. Extrinsic semiconductor materials. n-type material results from impurities with excess electrons that can be donated to the conduction band. p-type material results from impurities with a deficient number of electrons which can accept electrons from the valence band. (a) n-type electron conductor; (b) p-type hole conductor.

energy locations that are available. The electrons are constantly seeking the lower energy levels but are constantly being excited to higher states by interactions such as with phonons and photons. For most cases the electron distribution in the allowed levels can be described by the Fermi function. Applying the Fermi-Dirac statistics, the probability $f(E)$ that a state of energy E is occupied by an electron is given by

$$f(E) = \frac{1}{\exp[(E - E_f)/kT] + 1}$$

where $f(E)$ is the Fermi function, E the energy of an allowed state, E_f the Fermi energy, k Boltzmann's constant, and T the absolute temperature. At room temperature the product of kT is equal to about 0.025 eV. The Fermi energy or Fermi level is by definition the energy at which the probability of a state being filled is exactly one-half. Another way of looking at it is the highest energy state an electron can have at 0°K. Perhaps the most important characteristic of the Fermi level is that, in thermodynamic equilibrium, it is always continuous across the contact between two materials.

The distribution of electrons in the outermost or highest energy bands determine most of the electrical and thermal properties of the material. This is similar to the outermost electrons in an atom, the valence electrons, that mostly determine the atom's chemical characteristics. If a crystal (for example, most metals) contains an outermost band which is partially filled, an externally applied electric field can shift the occupation of the energy levels and cause a current to flow. If a band of energy states is completely empty, there can, of course, be no contribution to an electric current by that band. Similarly, if a band is completely filled, there can be no contribution to an electric current by the band. These materials are then good electrical insulators (see Fig. 1).

The highest occupied band corresponds to the ground state of the outermost or valence electrons in the atom. For this reason the upper occupied band is called the valence band. In an insulator, the valence band is full. In addition, the width of the forbidden energy gap between the top of the valence band and the next allowed band, called the conduction band, is so large that under ordinary circumstances a valence electron can accept no energy at all from an applied field, because there are no empty allowed states accessible to it. Semiconductors are similar to insulators, except that in

semiconductors the forbidden gap is much narrower. For example, alumina (Al_2O_3) at room temperature has an energy gap (E_g) of 10 eV while the semiconductor germanium has an energy gap of only 0.7 eV. In a semiconductor at room temperature, though the valence band is full, some electrons have enough thermal energy or may receive enough energy from light so that they may jump the narrow forbidden energy gap into the empty conduction band. The higher the temperature or the higher the intensity of the light source, the larger the number of electrons that will be excited across the gap. (Recall the Fermi function.) The electrons that are so raised are then free to accept electrical energy from an applied field and to move through the crystal. In addition, the sites or "holes" left vacant in the valence band become charge carriers themselves. An electron near a hole can jump in and fill it, leaving a new hole in the place it had occupied, and this in turn can be filled by a neighbor, and so on. Current is actually carried by electrons moving in relays but it can equally well be pictured as a flow of positively charged holes moving in the opposite direction. Thus conduction is done by both electrons and holes. When the conduction of current is due only to those electrons excited up from the valence band to the conduction band, the material is called an intrinsic semiconductor.

Any disruption of the perfect crystal will disturb the periodicity of the system and result in additional energy levels within and between the allowed bands. Imperfections in crystals usually come from four sources:

- (1) foreign atoms substituted into lattice sites;
- (2) vacant lattice sites and interstitial atoms;
- (3) dislocations of the crystal (or grain boundaries);
- (4) the crystal surface.

The technology for producing low-defect crystals, has been developed by using ultrahigh purity material and in slowly growing large, single grain crystals. However, with carefully controlled impurity levels it is possible to obtain desirable properties for semiconductors. By adding small amounts of impurities called dopants to semiconductor crystals, it is possible to choose the dominant type of conduction (either electrons or holes) in a material. When the conduction is due to impurities, the material is called an extrinsic semiconductor (Fig. 2). Impurities can supply extra electrons, negative charge carriers, in which case they are called n-type materials (Fig. 2a). If the impurities are deficient in valence electrons, they are

called p-type, positive charge carriers (Fig. 2b).

Figure 3 shows the physical arrangement of added impurities to a two-dimensional silicon crystal. Figure 3a shows the normal bonds that exist by the shared electrons in a perfect silicon crystal. By substituting a phosphorous atom as in Fig. 3b, there is an extra electron available. Since it is only held in position by the coulomb attraction to the phosphorus nucleus, it can be removed and made a conduction electron with far less energy than that required to move a valence electron across the band gap (i.e., remove a shared electron used in normal bonding). In a similar way, an impurity such as the aluminum in Fig. 3c has a deficiency of one electron that a silicon neighbor would like to share. A valence electron can jump into the location with far less energy than would be required to jump the forbidden energy gap, thus creating a hole in the valence band for positive charge conduction. These types of impurities thus provide allowable energy levels for an electron which are within the forbidden gap of the basic crystal. The extra electron case of Fig. 3b provides a "donor level" as in Fig. 2a that donates electrons as the majority charge carrier in this material called n-type. The extra hole case of Fig. 3c results in providing an acceptor energy level E_a as in Fig. 2b that accepts electrons from the valence band, thus making the holes the majority charge carrier in this p-type material.

In intrinsic semiconductors the Fermi energy is exactly in the middle of the forbidden energy gap ($E_f = E_g/2$) and there are the same number of conduction electrons as there are holes. As seen in Fig. 2, the Fermi energy in an extrinsic semiconductor is shifted toward the acceptor energy level (E_a) or the donor level (E_d) depending on the nature of the impurity. The exact location of the Fermi energy in these materials depends on the doping level (impurity atoms per cubic centimeter) and the absolute temperature. This dependence is qualitatively shown in Fig. 4. Each impurity site provides one electron or acceptor location. Once these sites have been used, the material acts as an intrinsic semiconductor. This can be seen in Fig. 4. As the temperature increases, more impurity sites are used and eventually the number of electrons thermally excited across the forbidden energy gap is large compared with the impurity doping level and the Fermi energy approaches the intrinsic level of $E_g/2$. The effect increasing temperature would have on a p-n junction solar cell is to bring the Fermi energies of both sides closer, thus reducing the output voltage and efficiency.

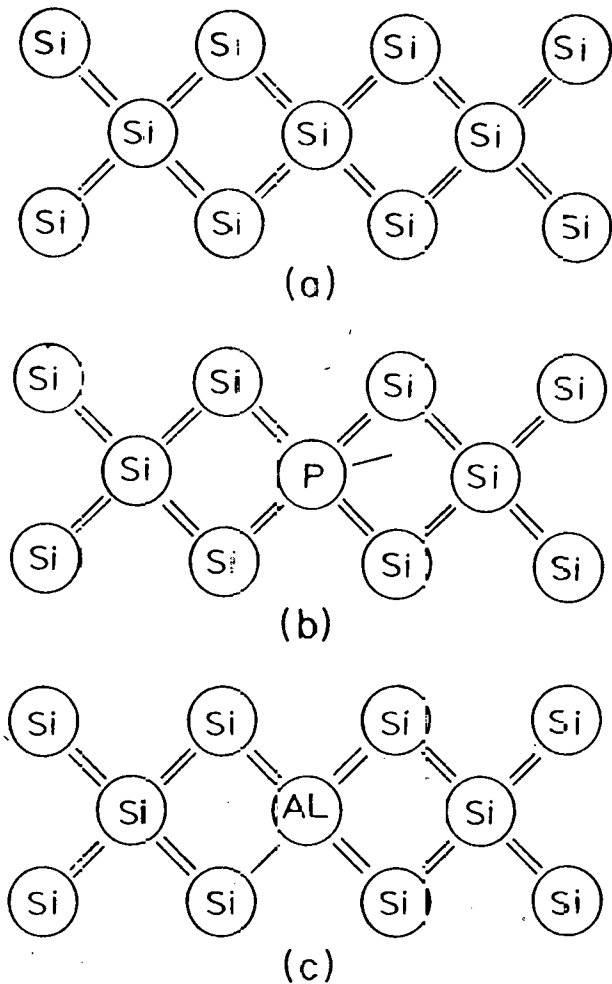

Fig. 3. Impurity atoms in a silicon lattice. (a) Normal silicon bonding. All 4 valence electrons in silicon form bonds with their silicon neighbors. (b) Excess electron impurity. Impurities such as phosphorus have 5 valence electrons and thus have an excess electron that can be easily removed to become a conduction electron. (c) Deficient electron impurity. An impurity such as aluminum has 3 valence electrons, providing a temporary site for one of the normal bonding electrons.

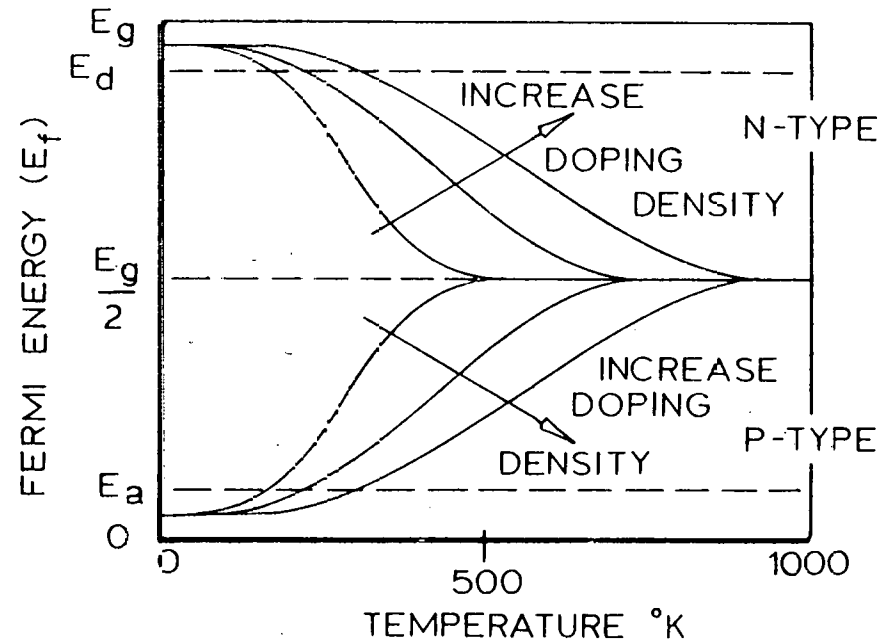

Fig. 4. Qualitative dependence of the Fermi energy on the temperature and doping level of the impurity. As all of the acceptor sites get filled with increasing temperature, or all the donor electrons get excited to the conduction band, the material approaches its intrinsic characteristics with the Fermi energy approaching the middle of the forbidden energy gap.

In order to obtain useful power from photon interactions in a semiconductor, three processes are required:

(1) The photon has to be absorbed and result in electrons being excited to a higher potential.

(2) The electron-hole charge carriers created by the absorption must be separated and moved to an edge to be calculated.

(3) The charge carriers must be removed to a useful load before they recombine with each other and lose their added potential energy.

The absorption of photons in a material is given as a function of distance into the material, x , as

$$I(x) = I(0)e^{-\alpha x}$$

where $I(x)$ is the intensity of photons at depth x , $I(0)$ the intensity incident on the material, and α the absorption coefficient. For example, if one takes a typical α of 10^4 cm^{-1} , then 90% of the photons would be absorbed in the first $2.3 \text{ }\mu\text{m}$ of the material.

The incoming photons with energies greater than the forbidden energy gap can be completely absorbed by an electron and jump the gap. Any excess energy the photon has over the minimum required ($E_{ph} - E_g$) is quickly given up to the lattice as thermal energy as the electron drops down to the bottom of the conduction band. For photons with energies less than the band gap, the material will appear transparent since there is no mechanism that would allow an electron to interact. Thus one would expect a step change in the absorption coefficient to take place as a function of incident photon energy at the energy of the band gap. This is indeed the case in many semiconductors and they are called direct absorbers. The steep absorption edge of several materials can be seen in Fig. 5. In order to explain the behavior of semiconductors that do not exhibit an abrupt change in α , one must go into band theory in more detail than in the simplified presentation above.

When one solves the quantum mechanical equations for a periodic potential in a crystal, the allowed energy bands are, in general, a function of a lattice parameter k . This parameter is a geometric factor related to the periodicity of the crystal, but it can be shown to be related to the momentum. Figure 6 shows the allowed bands as a function of k for two different types of semiconductors. The forbidden gap is always defined as the minimum vertical distance on this type of plot between the bottom of the conduction band and the top of the valence band. For an indirect absorption of a photon to

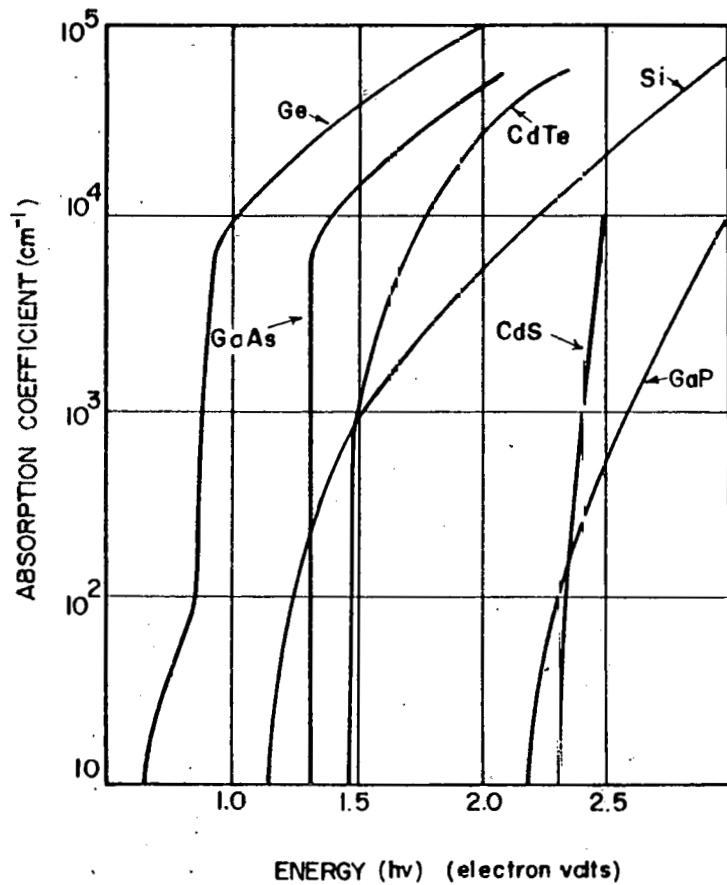

Fig. 5. The optical absorption coefficients as a function of photon energy for a number of materials of interest for solar cells. Materials having steep curves (sharp absorption edges) are indicative of direct absorbers and could be made into thin film solar cells.

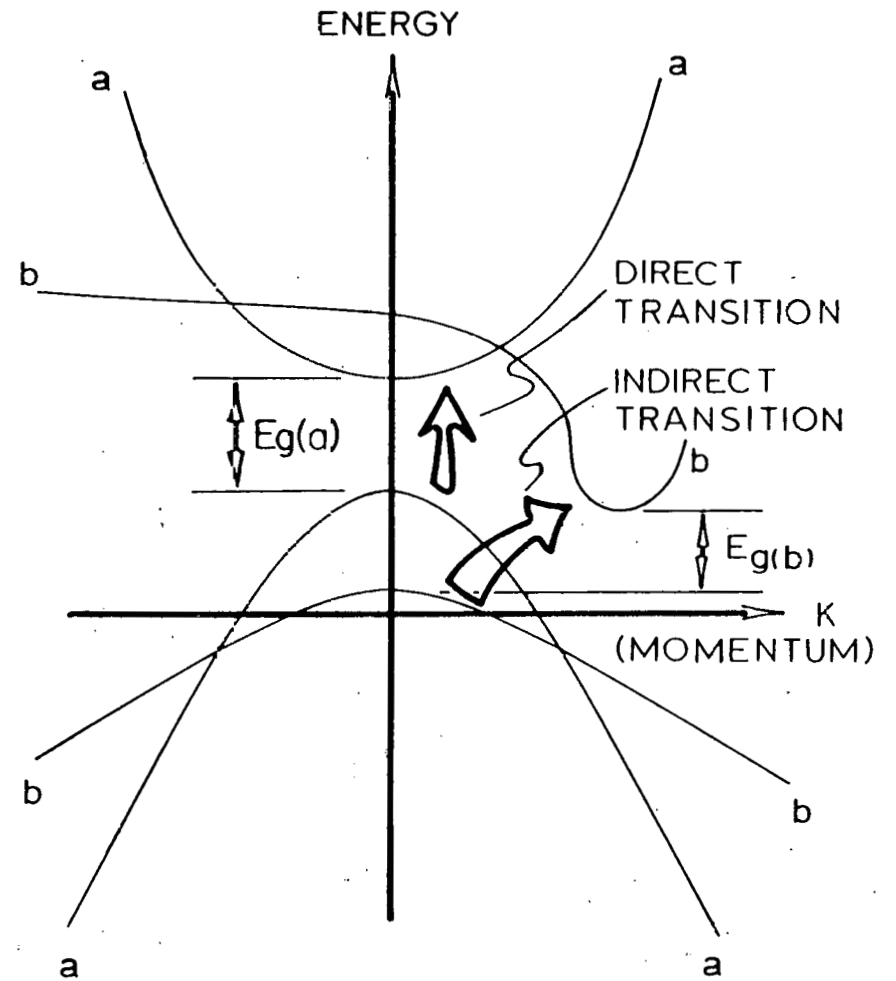

Fig. 6. The forbidden energy gap as a function of the lattice parameter k (related to the momentum) for 2 different semiconductor materials, a and b. Material a is a direct absorber. Also depicted are the electron transitions across the gap. Direct transition does not involve a change in momentum.

take place, it requires the interaction of a photon, an electron, and a phonon from the lattice to provide the momentum change. A photon having an energy greater than E_g may have a rather deep penetration before the interaction conditions are met. This results in an absorption coefficient that depends on the energy of the photon, and only starts to increase at the band gap energy and slowly increases to large values that would allow a direct transition to take place at the $k=0$ distance between bands. Semiconductors that have their minimum in the conduction band and their maximum in the valence band at $k=0$ are called direct absorbers. Semiconductors which have the maxima and minima at different k values are called indirect absorbers. Many of the materials being considered for solar cells are direct absorbers which will allow cells to be made from thin films. Silicon and germanium are indirect absorbers.

After the photons are absorbed and electron-hole pairs are created, the charges must be separated. In a typical solar cell this is done by use of p-n junction. Figure 7 demonstrates how this p-n junction provides an electric field that sweeps the electrons in one direction and the positive holes in the other. If the junction is in thermodynamic equilibrium, then the Fermi energy must be uniform throughout. Since the Fermi level is near the top of the gap of an n-doped material and near the bottom for the p-doped side, an electric field must exist at the junction providing the charge separation function for the cell.

A solar cell usually uses a p-n junction, as described earlier, in a physical configuration as shown in Fig. 8. The relationship between the current and voltage in an ideal p-n junction is given by

$$J_j = J_0 [\exp(Ve/kT) - 1] \quad (1)$$

where V is the voltage imposed across the junction, e the electronic charge, k Boltzmann's constant, and T the absolute temperature. The saturation current J_0 (sometimes called the dark current), is obtained when a large negative voltage is applied across the diode. When light impinges on the junction, electron-hole pairs are created at a constant rate providing an electrical current flow across the junction. The net current is thus the difference between the normal diode current and the light generated current J_L . Figure 9 shows the simplified equivalent circuit for the cell. The internal

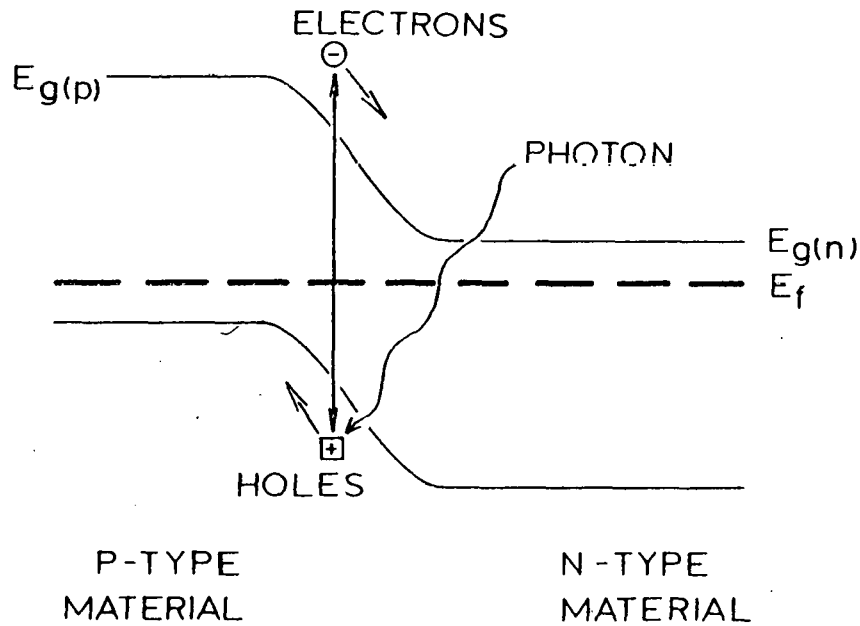

Fig. 7. The inherent electric field provided by a p-n junction which will separate the charge carriers after their creation by the absorption of a photon.

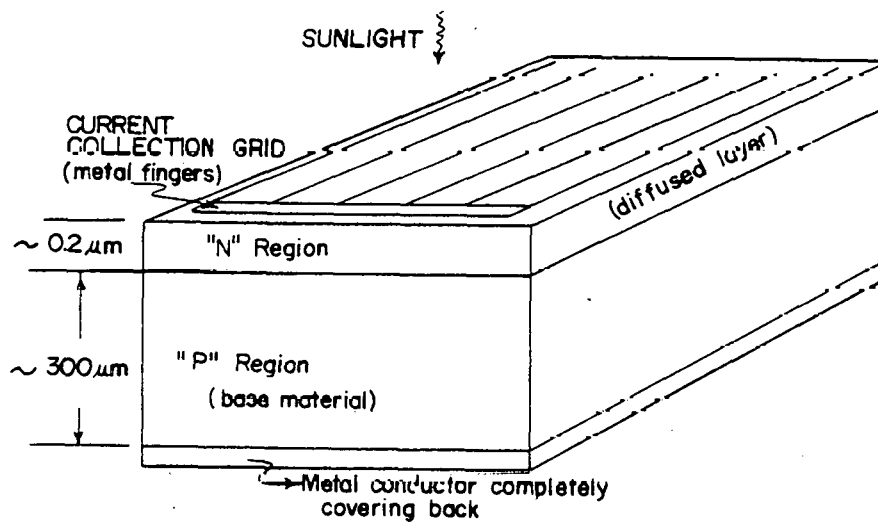

Fig. 8. Schematic of the physical configuration of a typical solar cell.

resistance R_s is mostly due to the high sheet resistance of the diffused layer which is in series with the junction. The net current J is given by

$$J = J_L - J_j = J_L - J_0 \{ \exp[(V + JR_s)e/kT] - 1 \} \quad (2)$$

The internal voltage drop in a cell can usually be minimized, and the assumption that is used for an ideal cell is that $R_s=0$. The corresponding J-V curve and electron potential diagram for an ideal solar cell are given in Fig. 10. It can be shown that the open circuit voltage V_{oc} for the ideal cell is given by

$$V_{oc} = (kT/e) \ln[(J_L/J_0) + 1] \quad (3)$$

For normal operation, J_L is several orders of magnitude higher than J_0 and the 1 in the equation can be neglected. Care must be taken in the use of Eq. (3) for predicting the temperature dependence of V_{oc} , because J_0 is a strong function of temperature. In practice the open circuit voltage of a cell usually decreases linearly with increasing temperature.

The point P_{max} on the J-V curve in Fig. 10 represents the maximum power point. The corresponding current and voltage for this point cannot be explicitly solved, but it can be seen that the maximum efficiency for the cell is obtained by dividing $J_{mp}V_{mp}$ by the total power density of the sunlight P_{sun} . In the evaluation of solar cells it is often convenient to use the terms defined in the equation

$$\eta = J_{mp}V_{mp}/P_{sun} = \underbrace{(J_L E_g / e P_{sun})}_{\text{Fill factor (curve factor)}} \underbrace{(J_{mp} V_{mp} / J_L V_{oc})}_{\text{Voltage factor}} (e V_{oc} / E_g) \quad (4)$$

The fill factor is used as a measure of how well a junction was made in a cell and how low the series resistance has been made. A typical value of the fill factor for a good silicon cell is about 0.8. The voltage factor is determined by the basic properties of the materials in the cell and is typically about 0.5 for a silicon cell.

Inspection of the above equations in light of the properties of semi-conductors, can give insight into characteristics of solar cells. First, the short circuit current is directly proportional to the light-generated current which in turn is linearly proportional to the intensity of sunlight on the

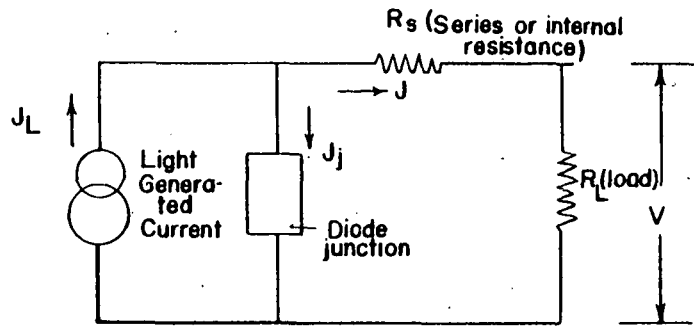

Fig. 9. The equivalent circuit for a solar cell showing the internal series resistance. The light-generated current acts as a constant current source supplying the current to either the junction or a useful load depending on the junction characteristics and the value of external load resistance.

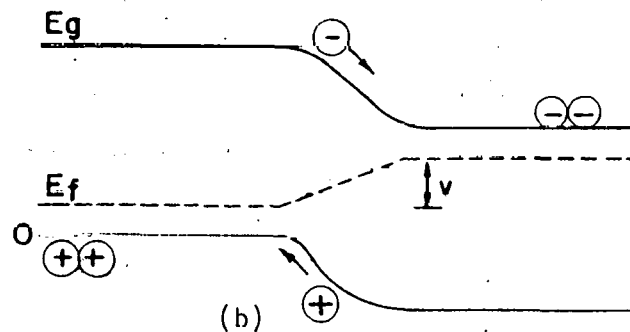
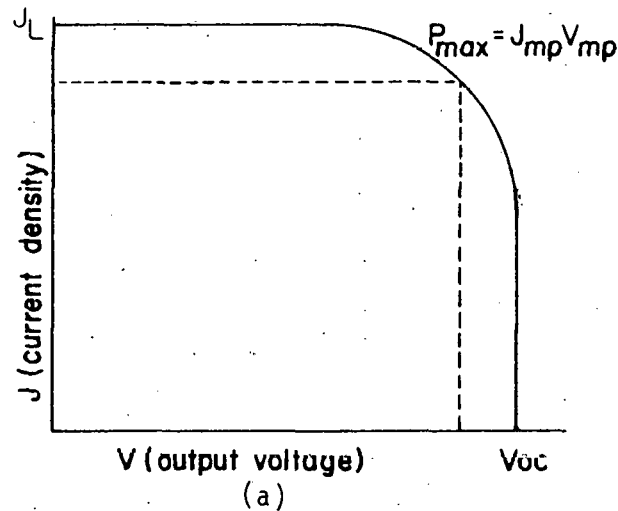

Fig. 10. (a) a typical current-voltage curve for an ideal solar cell with the short circuit approaching the constant light-generated current J_L . The maximum power point is shown as P_{max} . (b) A typical electron energy diagram for a p-n junction under illumination of sunlight with the external resistance set such that the output voltage is at value V . This same voltage V is thus imposed on the junction which will reduce the current delivered to the external load.

cell. The open circuit voltage increases as the log of the light intensity if the temperature is constant. Thus if the fill factor remains the same, one should expect the efficiency to increase as the log of the intensity of sunlight. Also as the forbidden energy gap of the semiconductor is increased, the open circuit voltage of the cell and its efficiency should increase. However, the light-generated current is due to the electron-hole pairs created by the absorption of photons whose energies are greater than the band gap of the semiconductors. When sunlight is used as an energy source, the number of photons available is a function of photon energy. The light-generated current will monotonically decrease with increasing semiconductor band gap values. Thus as a function of band gap energies, the expected cell efficiencies should first increase due to the increase in voltage, pass through a maximum, and then decrease due to the decrease in the light-generated current available. These expected efficiency curves have been calculated by assuming typical p-n junction characteristics and the solar spectrum. Figure 11 gives the results of one of these calculations with various semiconductor materials identified at their appropriate band gaps. As can be seen from this figure, p-n junction solar cell efficiencies cannot be expected to exceed the 20-25% range. Most of the limitation on efficiency is due to the energy spectrum of sunlight. The excess of energy that photons have above the band gap of the semiconductor is lost to thermal heating as the excited electrons drop down to the bottom of the conduction band. Photons with energies less than the band gap are all lost since they cannot excite any electrons. Because of this frequency mismatch, only about 44% of the energy in the solar spectrum is available to silicon for possible conversion to electricity (10). Figure 12 gives a bar chart of the energy losses in a typical silicon solar cell. As can be seen from this chart, significant increases could be made in cell efficiencies if they are used with a monochromatic source or if the solar spectrum could be modified to different wavelengths.

Performance Predictions for Photovoltaic Concentrator Cells

Until the last two or three years all solar cells produced have been optimized for a one sun illumination level. In the last two years the developing field of photovoltaic concentration systems has resulted in at least four manufacturer's developing and essentially commercially selling, silicon concentration cells. These four companies are listed in Table 1. The principle

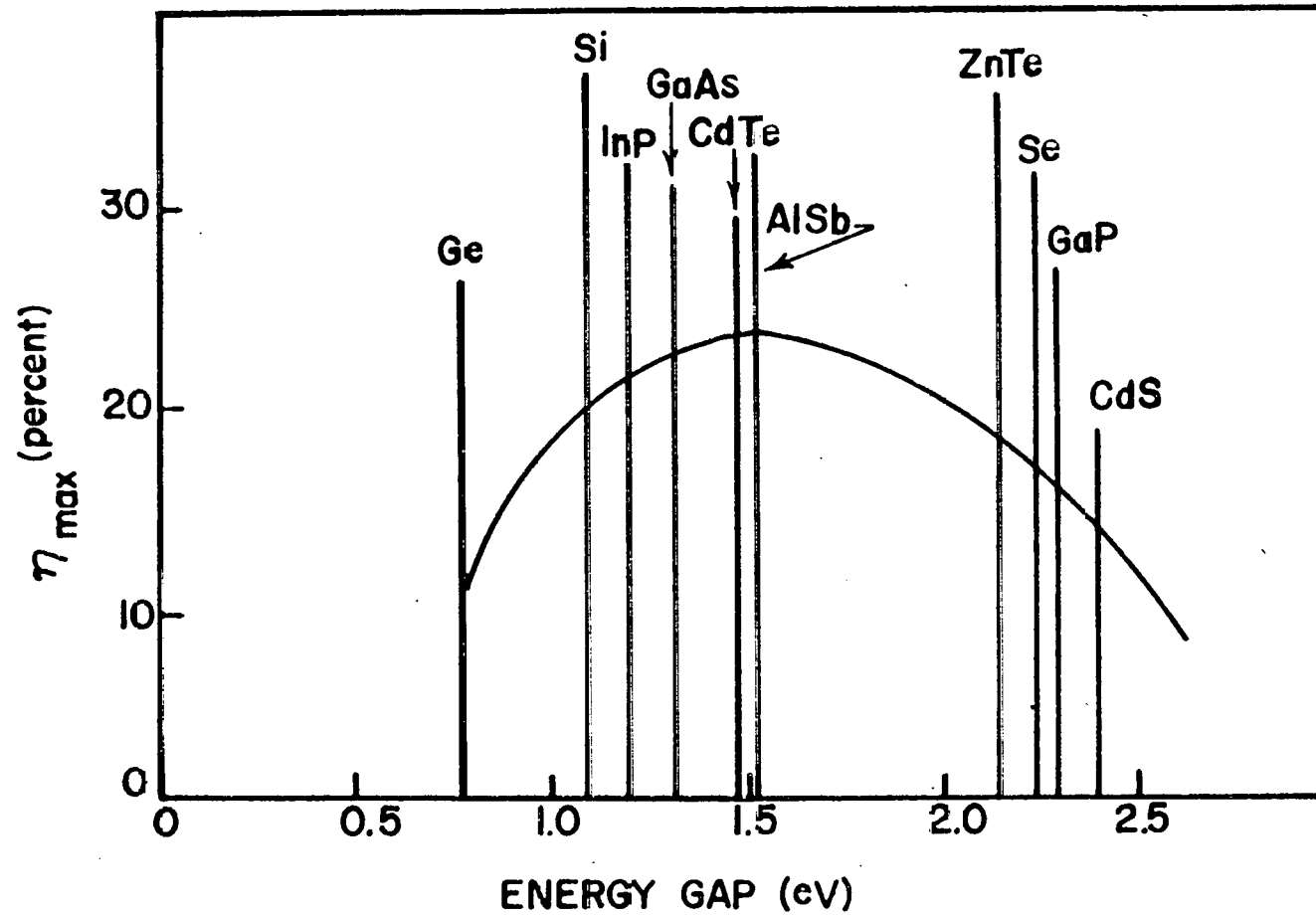

Fig. 11. A calculated curve of the maximum efficiency that can be obtained as a function of the energy gap of the semiconductor made into a p-n junction and illuminated with the solar spectrum outside the atmosphere, AMO (Loferski, 1963).

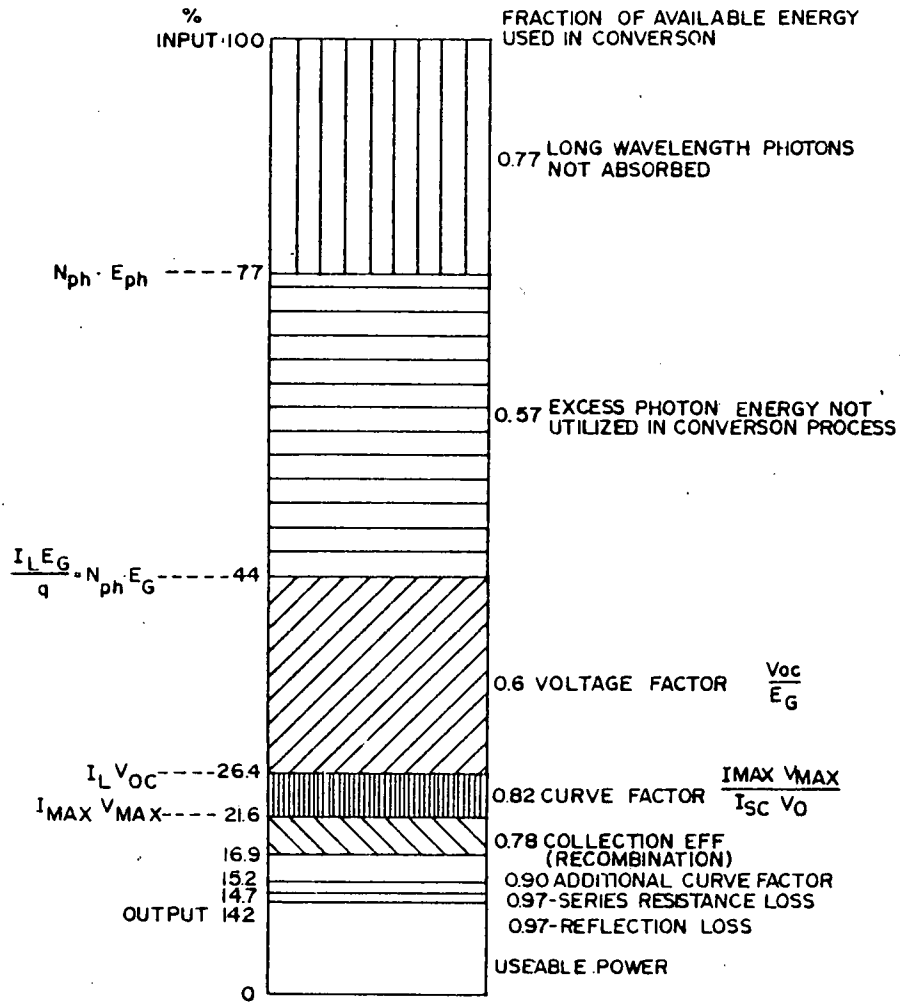

Fig. 12. Bar chart of the distribution of energy losses in the 1 ohm-cm p on n cell under illumination of an air mass one (AM1) spectrum sunlight. N_{ph} represents the number of photons in AM1 whose energies are greater than the bandgap of silicon, E_g . E_{ph} is the average energy of the photons in N_{ph} . The numbers on the left refer to the percent of the energy remaining after all of the losses above it have been counted. The numbers on the right refer to the fractional factor associated with the appropriate loss mechanism. I_{max} and V_{max} are the current and voltage at the maximum power point. The short circuit current (I_{sc}) is usually taken as identical with the light generated current, I_L (10).

TABLE 1
Suppliers of Silicon Concentration Cells

Company name	Address	Principal Contact
Optical Coating Laboratory, Inc.	2789 Giffen Ave. P. O. Box 1599 Santa Rosa, CA 95402	Ken Ling 707-545-6440
RCA Research Labs	Princeton, NJ 08540	Lou Napoli
Solarex, Corp.	1335 Piccard Dr. Rockville, MD 20850	Joseph Lindmeyer 301-948-0202
Spectrolab, Inc.	12484 Gladstone Ave. Sylmar, CA 91342	Eugene Ralph 213-365-4611

TABLE 2
Calculated Performances of Intrinsic n+p Silicon Solar Cells
With Various Base Resistivities at X = 1 and X = 50 Suns (T = 27°C)

ρ_{base} ($\Omega\text{-cm}$)	N_{AA} (cm^{-3})	X = 1 sun				X = 50 suns			
		J_{SC} (mA/cm^2)	V_{OC} (V)	FF	η (%)	J_{SC} (mA/cm^2)	V_{OC} (V)	FF	η (%)
10.	1.2×10^{15}	33.1	0.529	0.804	15.2	1820.	0.603	0.715	17.0
0.9	2.0×10^{16}	32.3	0.590	0.813	16.8	1670.	0.702	0.809	20.5
0.3	1.0×10^{17}	31.5	0.598	0.812	16.5	1590.	0.729	0.802	20.1
0.1	5.0×10^{17}	28.9	0.591	0.814	15.0	1450.	0.718	0.810	18.2

TABLE 3
Calculated Performances of Intrinsic n-p-p+
and p+-n-n+ BSF Silicon Solar Cells
($N_{\text{B}} = 1.2 \times 10^{15} \text{ cm}^{-3}$) at X = 100 Suns
Compared to the Performances of Their
n+-p and p+-n Counterparts (T = 27°C)

Structure	J_{SC} (A/cm^2)	V_{OC} (V)	FF	η (%)
n+-p	3.68	0.615	0.725	17.7
n+-p-p+	3.66	0.742	0.792	23.3
p+-n	3.8	0.71	0.73	21.3
p+-n-n+	3.76	0.777	0.795	25.1

consideration for the design of concentration cells comes from the high electric currents expected. If 100 suns of intensity is incident on a solar cell, then 100 times the electrical current is generated in the cell at essentially the same voltage as a one sun illumination. The high currents generated require changes in the basic cell design.

As discussed in the previous section concerning Eq. (1), (2) and (3), one would ideally expect the efficiency of a solar cell to increase with concentration. If the fill factor remains the same, the open circuit voltage increases as the log of the intensity and thus the efficiency should increase logarithmically with increasing light intensity. This is experimentally observed. If one tests a cell under increasing concentration it is observed that this logarithmic increase initially occurs but eventually the efficiency decreases due to the effects of high current flow. The decrease may be due to the effective increase in temperature, thus reducing the open circuit voltage, or to a increase in the voltage drop across the series resistance of the cell causing a decrease in the fill factor. Figure 13 shows the effect of increasing the series resistance, R_s , given in Eq. (2) on the electrical output of a typical solar cell (11). Calculations in the figure assumes electric currents indicative of a one sun illumination. As the current increases under higher illumination, the effect on the IV curve and power output are similar but for much lower values of R_s . Therefore, a solar cell with an acceptable value of R_s for one sun illumination may not have sufficiently low R_s to be acceptable for higher illuminations.

The value of R_s in a solar cell is mostly due to the high electrical resistance in the top thin layer on the cell (see the "n" region in Fig. 8). The current generated by the absorption of light must pass through this thin layer before it reaches a good electrical conductor represented by the grid fingers. There are three approaches that would seem obvious for the reduction of R_s . One approach would be to increase the junction depth such that the cross sectional area in the "n" region seen by the flow of electrons would be much larger and therefore have a lower resistivity. The second approach would be to use a very low electrical resistivity material in the "n" region. The third approach would be to have a more complete coverage of the surface by the metal grid fingers. Analytical and experimental investigations have shown that increasing the junction depth makes the cell less responsive to the short wavelength photons in the solar spectrum. Thus deeper junctions

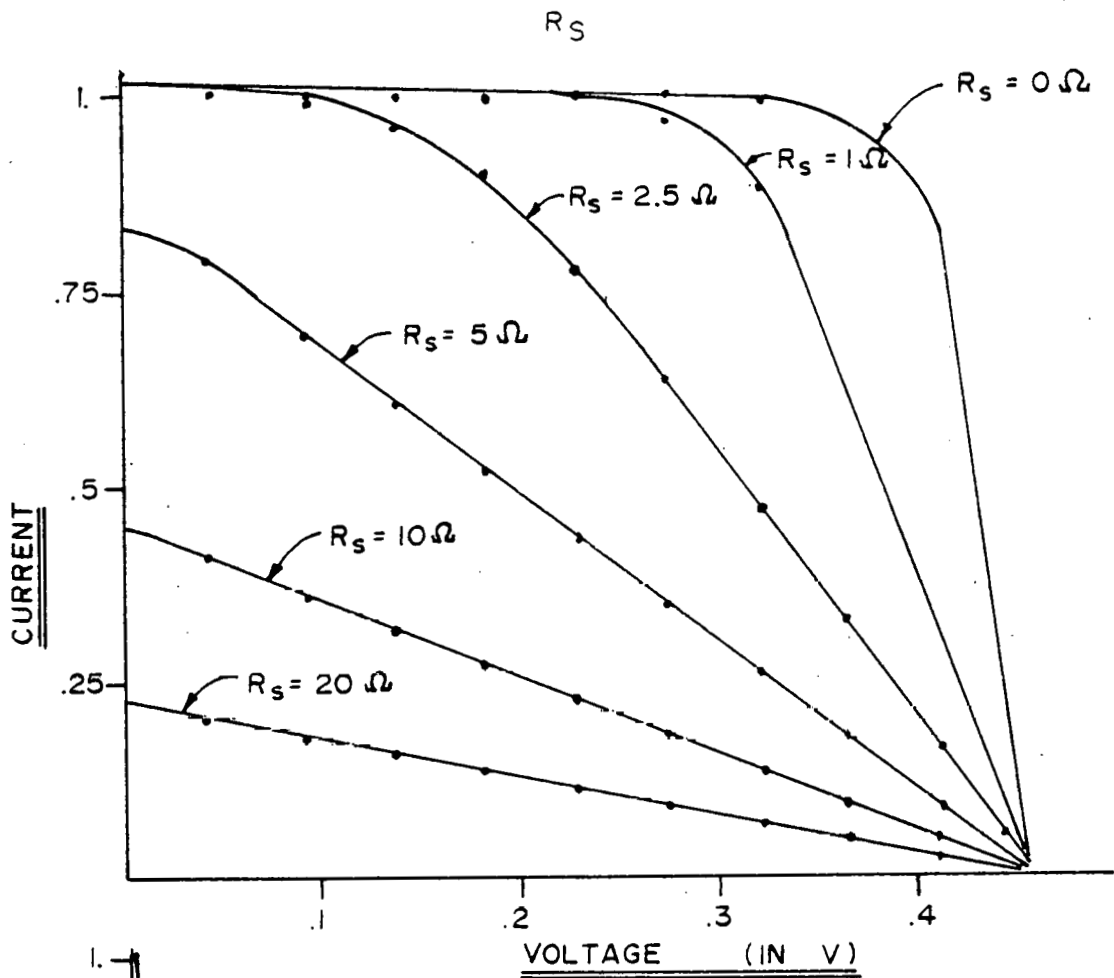

(a)

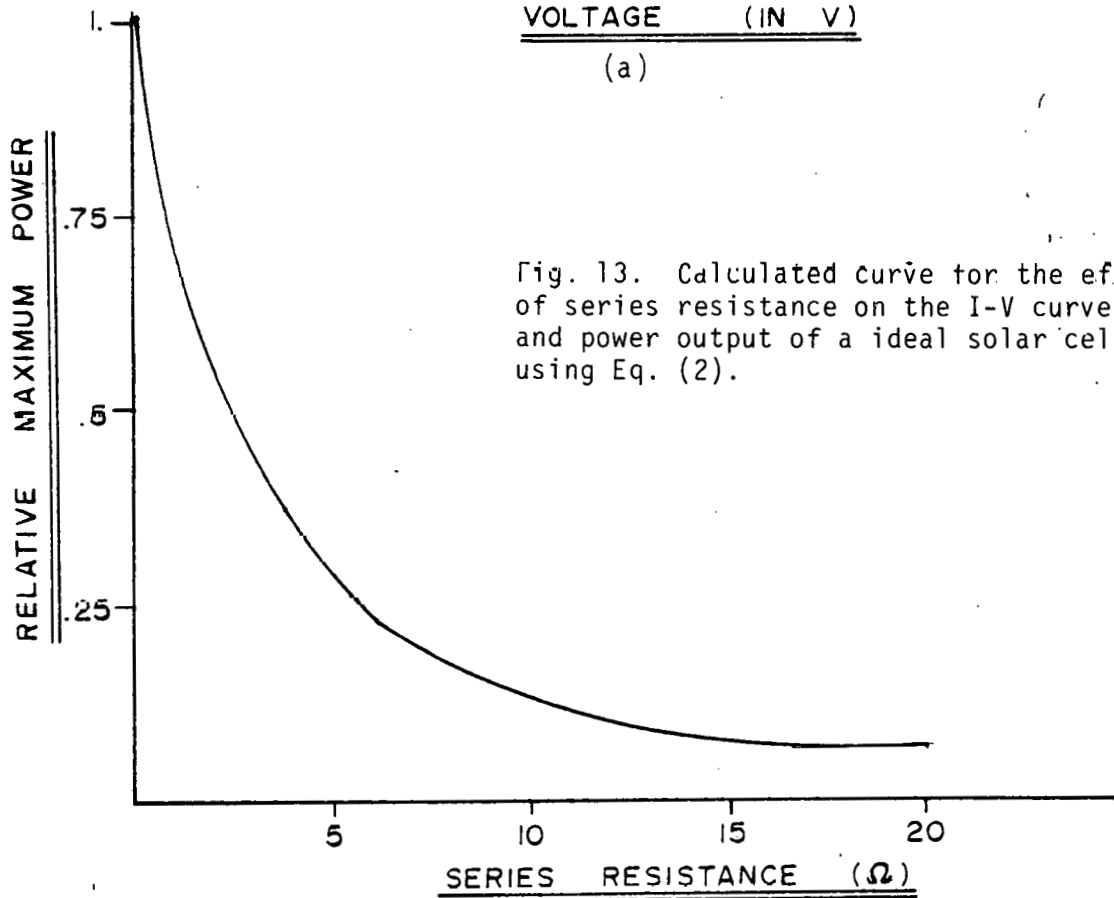

(b)

result in greater losses in the output of the cell than is gained from the reduction of the R_S value. The conductivity of both the "p" and "n" regions can be increased by increasing the doping level of impurities in those regions and lower values of R_S can indeed be achieved. There is a limit, however, of the R_S value that can be achieved by this method because of detrimental effects of extremely high density levels of impurities in these regions. The most successful approach to date for lowering R_S is in going to a very fine but closely spaced grid configuration on the surface. Since the grid fingers shadow the junction beneath them and thus decrease the output proportional to the area coverage of the grid fingers, it is desirable to go to very fine fingers that are just spaced close together. Most cells designed for one sun illuminations have about 5% of the surfaces covered by the grid fingers. Present day concentration cells also use only 5% of the surface area for the grid fingers.

One flexibility that is available in the design of concentration cells is that the focused beam of light on the cell may not cover the entire area of the front surface. For example, the main collecting grid on the bar going down the side of the cell as seen in Fig. 8 may be out of the focal zone. That would allow this main collecting bar to be designed large without the penalty of shadowing the junction underneath. It is thus becoming common now to report the efficiency of a concentration cell as the electrical output of the cell divided by the energy incident inside these large collecting bars. This basis for calculation of efficiency can increase the reported cell efficiency by one or two percentage points (e.g., from 15.5% to 17%).

In the design of cells especially made for concentration applications, one can consider trying to optimize the standard configuration used in making cells or consider a complete change in the geometrical configuration that may be more desirable for high illumination applications. Table 2 gives the results of a calculation showing the effect of changing the resistivity of the base region in a standard planar design silicon solar cell (12). This model would indicate that an optimum base resistivity is between 0.3 to 1 ohm-cm silicon material. One can also see in this table the increased efficiencies obtained by concentration compared to one sun level. One can also enhance the output of concentration cells by slight variations of the structure of the device as seen in Table 3. These calculations show that the existence of a back surface field (BSF) considerably increases the output of the cells

compared with the conventional n on p or p on n cell.

Another way of trying to reduce the series resistance effects at high illumination levels is to completely change the geometry of a converter. The vertical multi-junction solar cells shown schematically in Fig. 14 have been studied by many investigators (13, 14, 15). Although the early work in the investigation of VMJ cells was aimed at developing devices for high efficiency at one sun illumination, more recently their configuration has been studied for concentrator applications (16, 17, 18, 19, 20). This configuration has the edge of the junction exposed to the incoming solar radiation. The original intent of this design was to improve the efficiency since there would be a junction near where a photon was absorbed regardless of the depth of absorption. It was expected that the spectral response of this configuration would be superior to a conventional planar cell as seen in Fig. 8. In practice the VMJ cell did not show superior efficiencies to the conventional cells. They did, however, show greater tolerance of radiation damage in space and have been produced especially for that application. For concentration applications, this cell configuration has the advantage of reducing the overall current since typically these cells are connected electrically in series. With the edges illuminated by the sunlight, the total current going through all of the cells is very small but the voltage is additive. Therefore a given area VMJ cell may produce 1 milliamp of current at 100 volts whereas a same area conventional cell would produce 200 milliamps at 1/2 volt. Even as the intensity is increased a factor of 100 or 1000 the currents flowing through the cells would still be sufficiently low that series resistance would not have much effect on voltage reduction. To date these cells have not experimentally yielded any higher conversion efficiencies under concentrated sunlight than conventionally designed cells (2).

Another geometrical configuration shown schematically in Fig. 15 is called the interdigitated solar cell (21, 22). The advantage of this cell for concentration applications is that it does not have a thin layer of material that the current has to flow through as the case in the conventional design, therefore, it does not have a serious series resistance problem. Although this cell has received little development work it has already shown experimental efficiencies comparable to other concentration cells.

Another major parameter of interest in concentration cell applications is their performance relative to temperature. Figure 16 shows the calculated

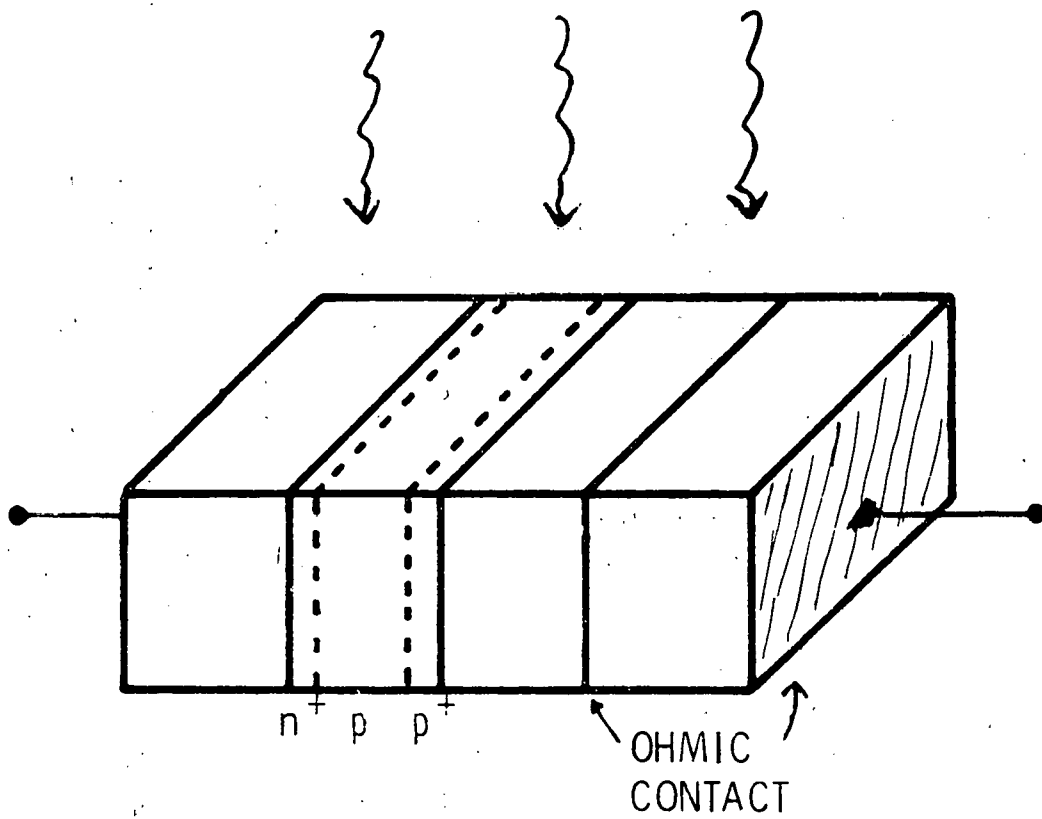

Fig. 14. Vertical multijunction solar cell (23)

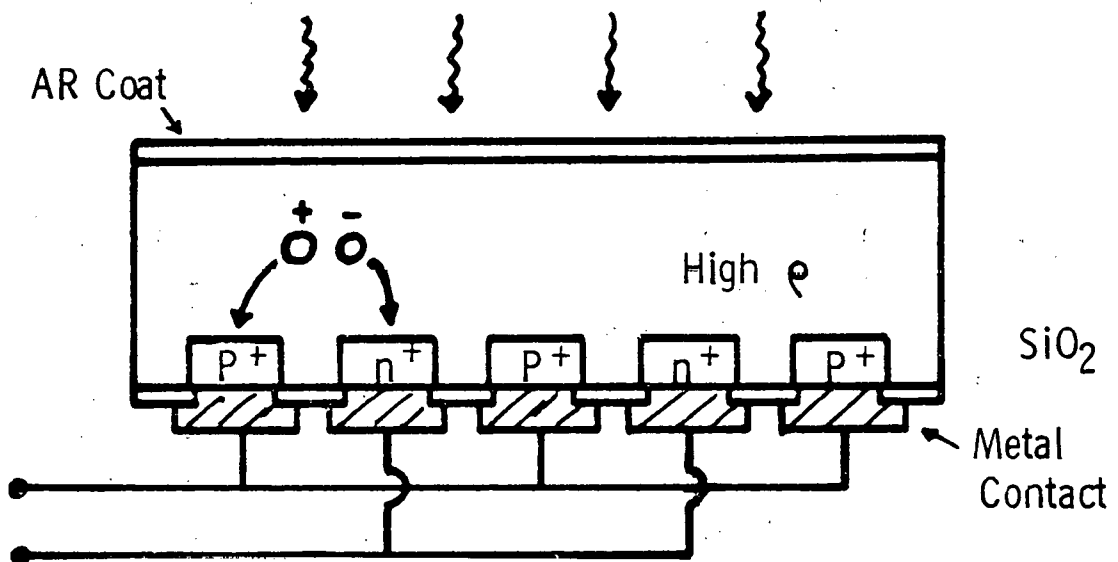

Fig. 15. Interdigitated solar cell (23)

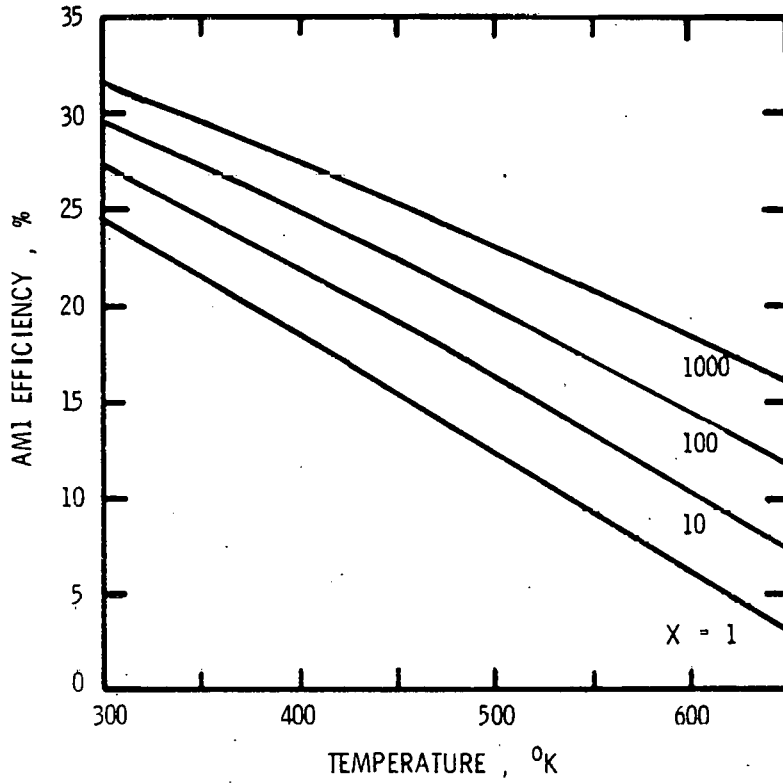

Fig. 16. Calculated inherent efficiency vs. temperature (23)

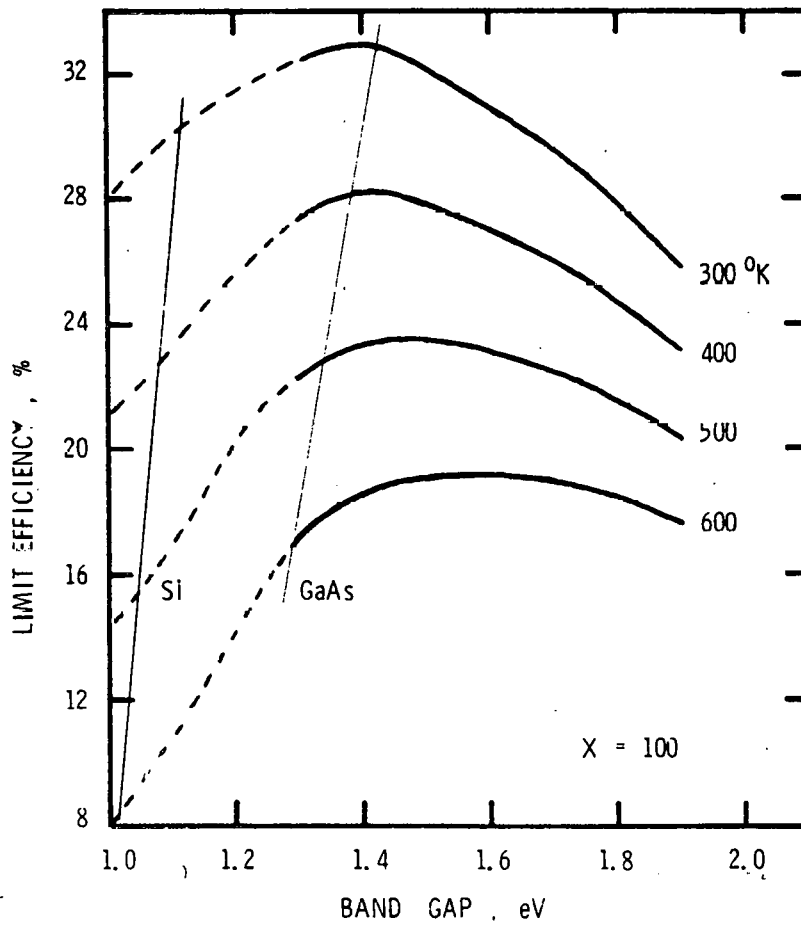

Fig. 17. Limit conversion efficiency at 100 AMI suns vs. bandgap and temperature. The straight lines represent the Si and GaAs bandgaps (23)

efficiency as a function of temperature for various concentrations of sunlight onto a silicon solar cell. This predicted linear decrease with temperature is primarily due to the drop in the open circuit voltage of the cell which is linear with temperature. Figure 17 shows a comparable plot as seen in Fig. 11 for various temperatures above ambient conditions. It is seen that as the temperature increases the optimum bandgap energy also increases. Thus for higher temperature operation, large bandgap materials such as gallium arsenide would have considerably better performance than with a lower bandgap material such as silicon. For this temperature resistance and also its high potential efficiency at room temperatures, gallium arsenide has received a great deal of attention for concentrator applications. A major change in the design of gallium arsenide cells in the early 1970's has led to a significant increase in their efficiencies (24, 25, 26, 27).

In May 1977 a workshop was held in Scottsdale, AZ to determine the current status and future of photovoltaic concentrator systems (28). The conclusions and recommendations of the silicon cell technology group at that workshop are given in Appendix A. Appendix B contains the problem areas and recommendations of the gallium arsenide and novel approach working group.

Current State of Technology

The field of photovoltaic concentration systems is rapidly changing. It is emerging from a laboratory, small component testing phase into a system design and field testing stage. For the reporting of the current state of technology in these systems it is presumed that the reader is more familiar with the optical concentrator state of technology and emphasis will be placed on concentrator cell testing and performance to date.

On cell testing considerations:

The standardized testing of solar cells for a normal terrestrial environment has been the subject of several papers and workshops (29-31). The major uncertainty in the testing procedure is the spectral distribution of the light source. A cell's output may vary considerably when tested under two different solar simulators that have the same energy intensity output. The varying atmospheric effects on the spectral distribution of sunlight also makes it difficult to test the cells in "standard" sunshine. The testing of solar cells under concentrated sunlight is considerably more complex than for one sun testing and no attempts have been made to establish standard testing procedures. Uncertainty in testing comes from energy intensity determination, the controlling and measurement of effective cell temperature and the problems introduced by high electrical currents.

The spectral distribution of the energy in concentrated sunlight will be somewhat different than the conditions of one sun, and will depend upon the type of concentration system used. A minor reason for the difference is that only the uncollided direct component of sunlight is concentrated and not the diffuse sunlight. A more major difference in spectral content is due to the effects of the reflective surface or refractive material. All of the materials used will have reflectance and transmittance characteristics which are a function of wavelength. These properties can, of course, be measured and as a result the spectral content of the energy incident on the cell can be predicted. If the spectral response of the cell is known then one can predict how the spectral shift will affect the output of the cell.

The prediction or measurement of the energy density in a concentrator is difficult because it depends upon the geometrical accuracy of the reflector and/or refractor, the reflective and refractive properties of the concentrator and how they change with time, and the type and accuracy of the tracking method used. The large intensity gradients encountered near the focal point or line of the concentrator makes it difficult to make and to interpret the measurements of intensity. The geometry and spectral response of the measuring instrument is critical when trying to predict the actual intensity on a cell that has a geometry different from that of the detector. The detectors used are usually thermal detectors involving calorimeters, or radiometers that involve a thermal-pile. To have reliable measurements one must have a flat, wide band response detector with the exact aperture of the solar cell, positioned in the exact position in the concentrator as the solar cell. If this test procedure requires only partial illumination of the active area of the detector then the calibration of the detector cannot be considered reliable. Experience at ASU has indicated that these types of detectors are not highly accurate. For example, two detectors from the same manufacturer designed for different ranges but calibrated over an overlapping range indicated a difference in energy density of 20% between the two detectors. It is not clear how a steep energy gradient across a thermal detector affects its calibration. It is also not clear how the cell will respond when exposed to a steep intensity variation across the cell.

In essentially all concentration systems, cells will be exposed to the non-uniformity of illumination across the cell. Traditional space type cells have shown a variation in output depending on the location and uniformity of

of the illumination. To a large part this variation was due to the series resistance in the diffusion layer which resulted in a difference in output whether a spot of illumination was mid-way between contact fingers or near a collecting finger. The design of cells for high concentration has resulted in lowering the series resistance and one would expect these cells to be less sensitive to the uniformity of coverage. However the effect of variation of intensity has not been experimentally investigated. It may well be that the "effective" illumination level may be estimated by just averaging the energy density at the cell surface.

The determination of the cell's efficiency under concentrated sunlight is complicated by the geometry of the cell and the uncertainty in its actual illumination. The geometry concern is about what the active area of the cell really is. Cells designed for high concentration will probably have large bussbars on the edge of the cell to carry the high currents generated. Although these large ohmics cover a reasonable area of the cell, the systems will probably be designed such that the concentrated sunlight will fall between the bussbars. All of the efficiency data reported from ASU thus far has assumed the total area of the cell including the bussbars, which is the traditional way of reporting efficiencies for one sun cells. If only the area between the bussbars were used it would represent perhaps a 10% increase in the efficiency percentage. For concentration cells it is probably better to use the area inside the busses as the active area of the cell. This area will, of course, include the small collecting grid across the cell. The area correction is taken into account during the calibration of the cell under one sunlight of intensity.

As mentioned previously, it is usually difficult to determine the actual intensity on a cell from a measurement using a separate radiometer in the concentrated zone. For cells tested at ASU to date, a number of experiments have been performed which indicate that the short circuit current of the cell is perhaps the most accurate method of determining incident energy on the cell. During the one sun testing the short circuit current which corresponds to 100 mw/cm^2 is determined for the cell. It is then assumed that the ratio of incident energy and short circuit current remains constant at higher concentrations. Thus if a short circuit current is read for a cell under illumination whose short circuit current is 10 times that of the one sun level, then the concentration ratio is defined as 10 suns. This method has proven successful for concentrations up to 100.

suns. It has also been used for concentrations over 1000 suns but data has not been collected which will substantiate its validity. This linear relationship may well be dependent upon the particular cell being tested. We have established more confidence in the short circuit current method of determining intensity than any other method currently tried.

The temperature dependence of silicon concentration cells tested to date have indicated that they respond in the same way as one sun silicon cells. Figures 18, 19 and 20 give the temperature dependence of the open circuit voltage, the short circuit current and overall efficiency respectively (32). Figure 18 shows the linear dependence of open circuit voltage on temperature with only a slight change in slope as the intensity increases. Figure 19 shows that the short circuit current is essentially constant with temperature at various illumination levels. This is especially reassuring when one is using the short circuit current as a measure of the incident energy on the cell. The efficiency dependence on cell temperature shown in Fig. 20 is essentially linear for the low concentration levels indicated by the data points on this plot. The efficiency being about the same for a given temperature at a variety of different concentration ratios in this plot indicates that the decrease in open circuit voltage as a result of increased temperature is just about offset by the increase in efficiency due to higher concentrations.

The temperature characteristics of GaAs cells has not been extensively reported in the available literature. Preliminary data in Fig. 21 on the temperature dependence of the GaAs cells indicates that the slope of the temperature dependence decreases with increasing illumination (33).

For purposes of collecting experimental data it would be desired to test cells at a constant temperature as one increases the intensity. As cooling is increased with increasing intensity the temperature gradients become more severe and the effective temperature of the cell becomes more questionable. The method of cooling the cell and the method and location of monitoring cell temperature becomes more crucial at higher illuminations. Figure 22 shows a schematic of the system used to collect data reported in Figs. 18-20. In this system, the cell was heated from the back with an electric resistance heater and partially cooled by a slow flow of argonne gas above the cell. The purpose of the gas was primarily to provide an inert atmosphere for high temperature operation of the cell rather than for cooling

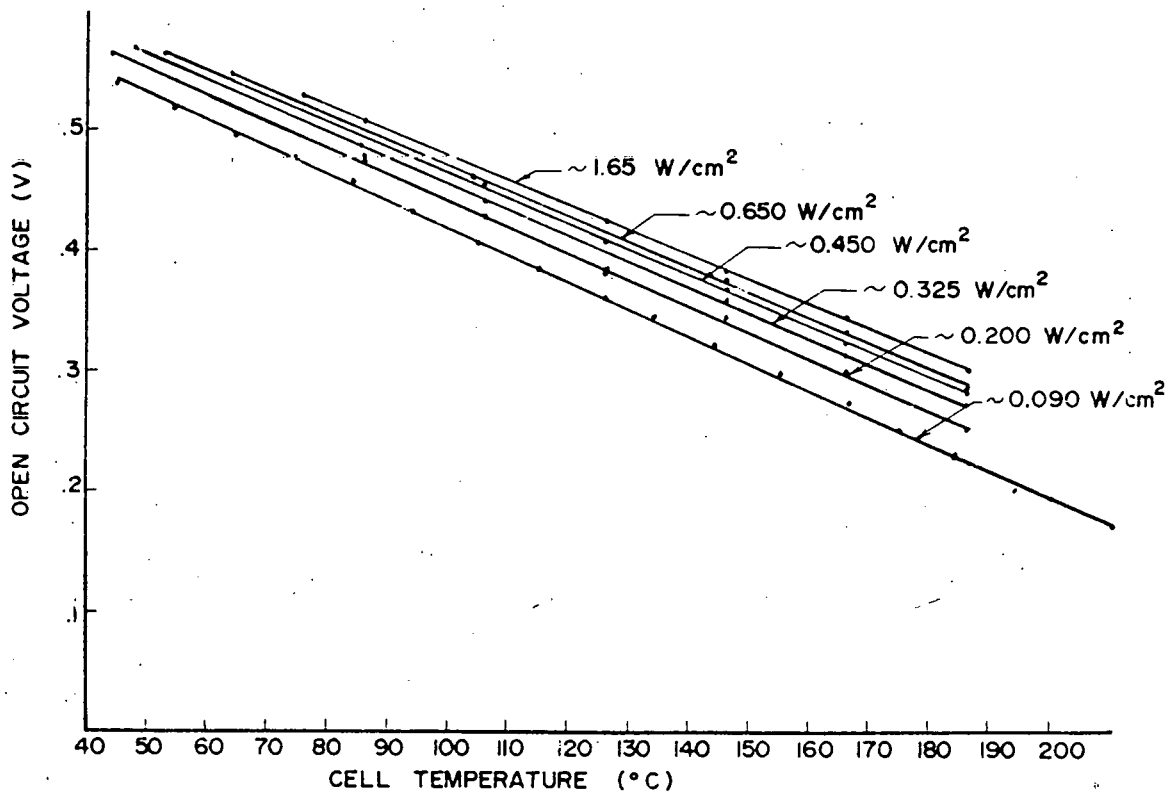

Fig. 18. Temperature dependence of open circuit voltage at varying intensity levels for a 2x2 cm concentration solar cell.

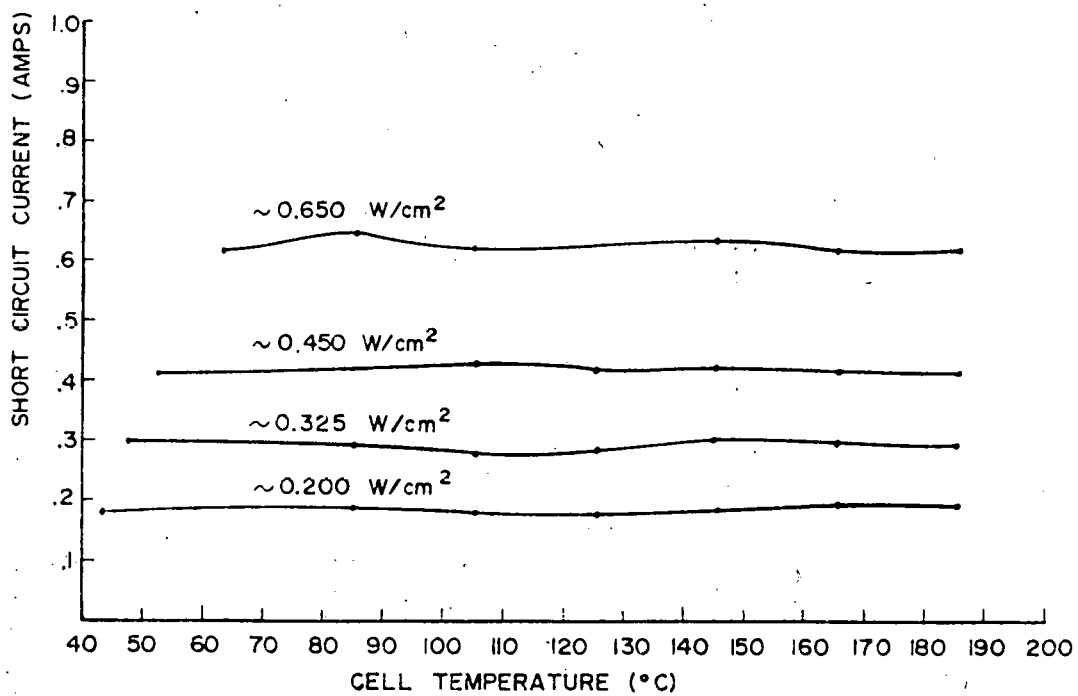

Fig. 19. Temperature dependence of short circuit current at varying intensity levels for a 2x2 cm concentration solar cell.

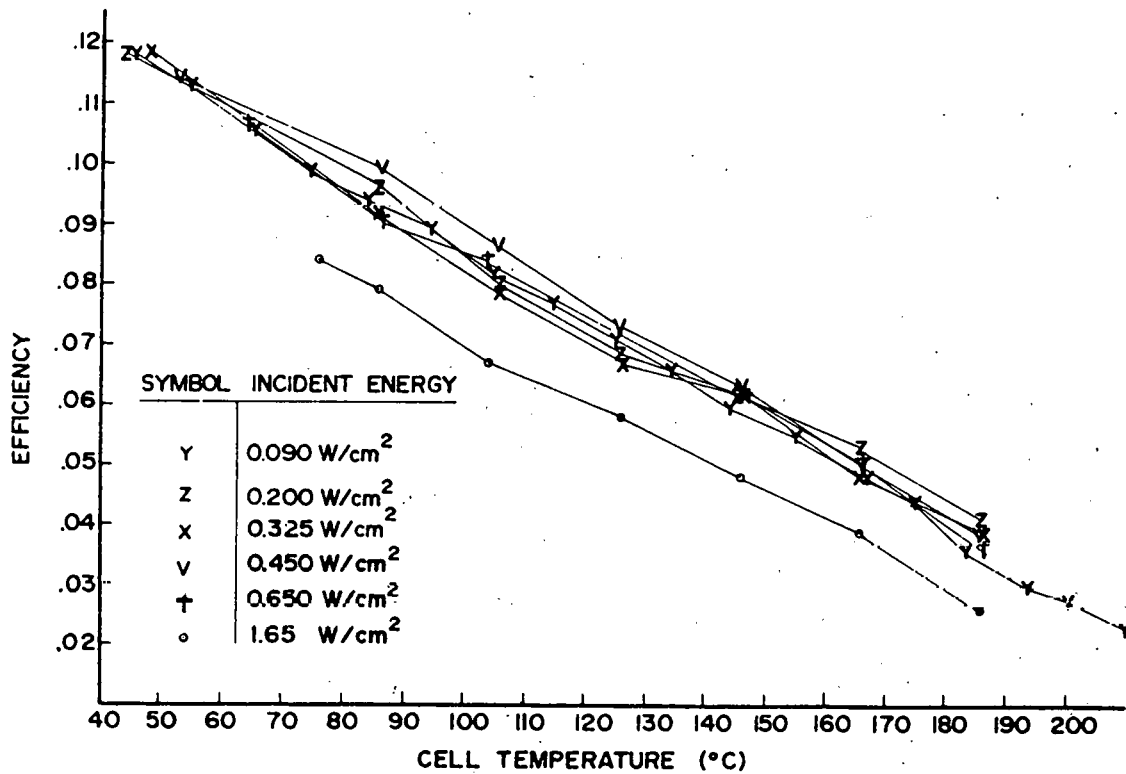

Fig. 20. Temperature dependence of efficiency at varying intensity levels for a 2x2 cm concentration solar cell.

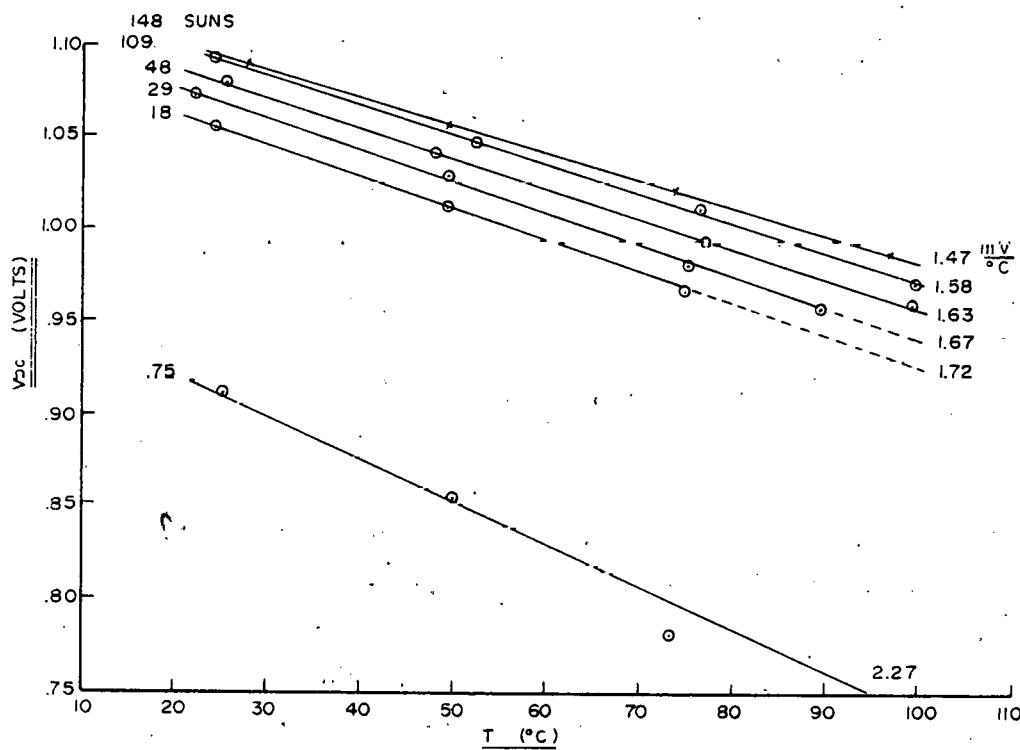

Fig. 21. The open circuit voltage for the Varian Ga-Al-As cell (10-11-77J RF1) as a function of temperature up to about 150 suns. The voltage temperature coefficient decreases considerably as intensity increases.

cell. The temperature was measured by an thermocouple mounted on the back of the solar cell. For concentrations under high illumination the heating is done by sunlight absorbed in the cell and cooling must be provided by either gaseous flow across the surface or cooling on the back surface of the cell or mounting plate. If the cell base plate is directly cooled with water under high illumination, the thermocouple located in this position may well monitor the temperature of the cooling plate rather than the cell temperature. Most testing at ASU has been done with the thermocouple mounted against the edge of the cell in such a way that it does not shadow the cell. Separate thermal experiments have indicated that a silicon cell of 2" diameter, illuminated under 100 suns intensity, will have a temperature of perhaps 30° C higher in the center than at the edge of the cell. Therefore the effective temperature of the cell may be difficult to estimate. One method that has been done by other experimenters is to assume the open circuit voltage dependence on intensity as logarithmic and adjust the cooling such that the open circuit voltage is the value that corresponds to the predicted value for that concentration. Experiments are underway to evaluate the validity of this approach.

There are additional temperature considerations for testing solar cells under concentrated light. The main thing is to ensure that none of the other components are adversely affected by the sunlight. For example, the electrical leads and thermocouple leads coming from the cell may be exposed to very high intensity sunlight without adequate cooling. It is very easy to melt electrical leads or burn insulation on the leads while the cell remains at an acceptable temperature. For cell testing at ASU the surrounding area near the cell is covered with a highly reflective tape to protect adjacent components from overheating.

Special consideration needs to be given to the electrical measurement of cell characteristics under concentrated sunlight. One of the uniquenesses of concentration cells is that the output current of a small cell can be in amperes rather than in milliamperes. This implies the need for proper measuring equipment and lead wires coming from the cell to ensure that the characteristics being recorded are due to the cell's output only. With high currents small contact resistances may become very significant. For testing at ASU we usually solder heavy wires onto the bussbars of the cell with at least two wires connecting the cell with the electronic load. The voltage monitoring of the cell is done with completely separate lines from that

used to carry the current. Again this is done with two separate lines in parallel going to the electronic load. The current lead coming off the back surface of the cell should usually be soldered onto the cell to ensure low contact resistance. Techniques such as using the cell mounting block for the cell electrical lead pickup can give misleading information due to the voltage drop across the adhesive. A better method would be the soldering of the cell directly onto the mounting plate. This may, however, present a problem during temperature cycling if the coefficient of expansion of the cell is different than that of the substrate. We have used Molybdenum substrates for a lot of the testing since Moly and silicon have similar expansion coefficients. There is, however, difficulty in soldering onto Molybdenum.

Results of Concentration Cell Testing;

The efficiency of cells not especially designed for concentration falls off very rapidly with increased intensity due to the voltage drop across the series resistance. Designing cells for high concentrations involves lowering the series resistance, primarily by the design of a fine grid pattern on the surface of the cell. The ideal cell would show an increase of efficiency as concentration increases due to the logarithmic increase of open circuit voltage with intensity and the linear dependence of a short circuit current. Typical cells, however, beyond a certain point of concentration start experiencing voltage drops due to the high currents and their series resistance levels which results in a decreasing efficiency as concentration continues to increase. Figure 23 shows the family of IV curves for concentrating varying from 11 to 36 suns. The peak efficiency is about constant for this range of concentration. This data was obtained through testing in a concentrator sunlight simulator (34). Taking the data by Spectrolab in Fig. 23 and plotting the maximum efficiency as a function of concentration results in Fig. 24. Also shown in Fig. 24 is the result of an experimental measurement at ASU on a similar but different cell made in actual concentrated sunlight. As one can see, they have the same general shape indicating the good approximation by the simulator. These cells from Spectrolab are 2 cm X 2 cm in dimension with large ohmic contacts going down two sides with 40 grid fingers crossing between the ohmics. The efficiencies reported are for the entire area of the cell including the large bussbars going down the edges. If only the active area of the cell is used for efficiency calculations then the peak efficiency goes from 15.2% to 17.8%.

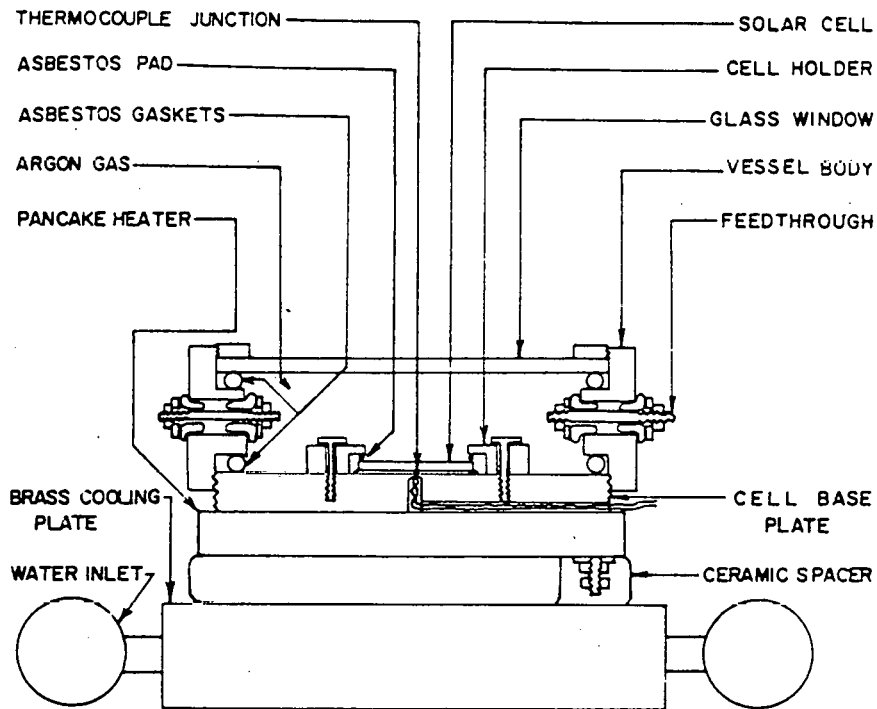
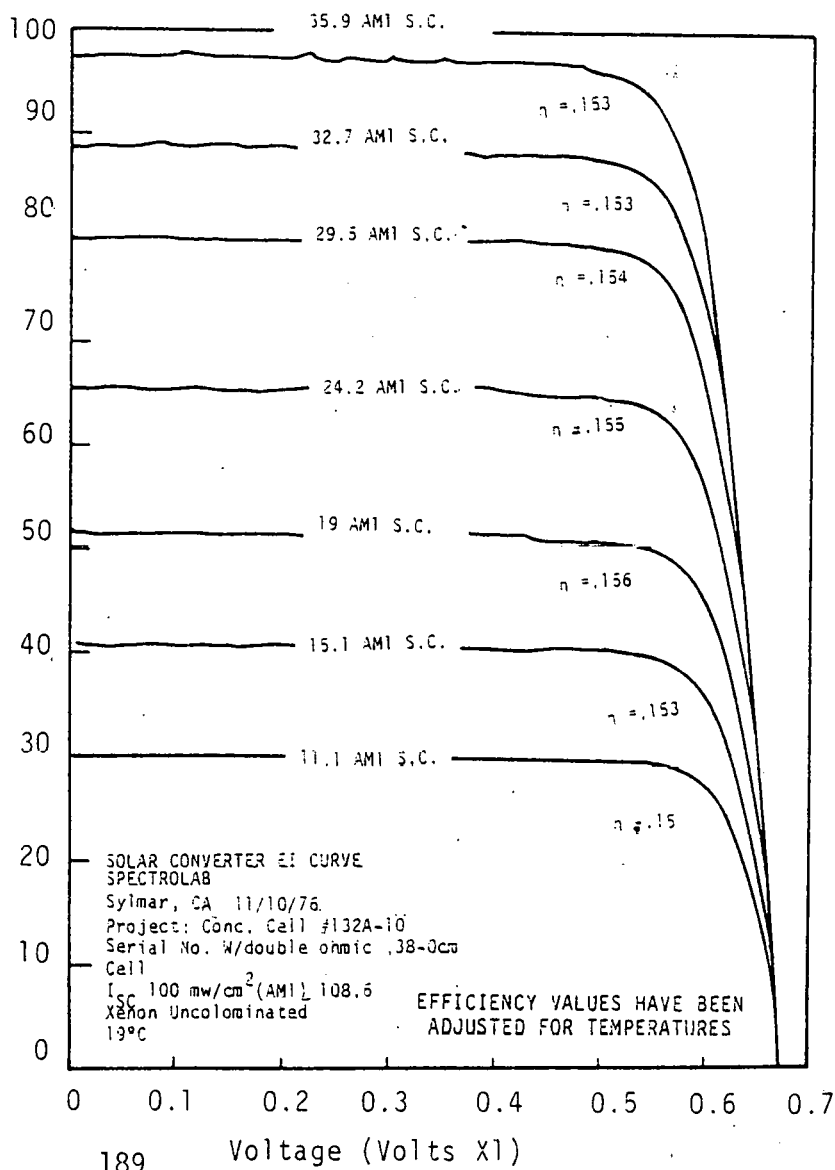

Fig. 22. Cutaway view of experimental arrangements for Cell Temperature Experiments.

Fig. 23. Current-voltage curves for a silicon concentration cell under test in a solar simulator (34).



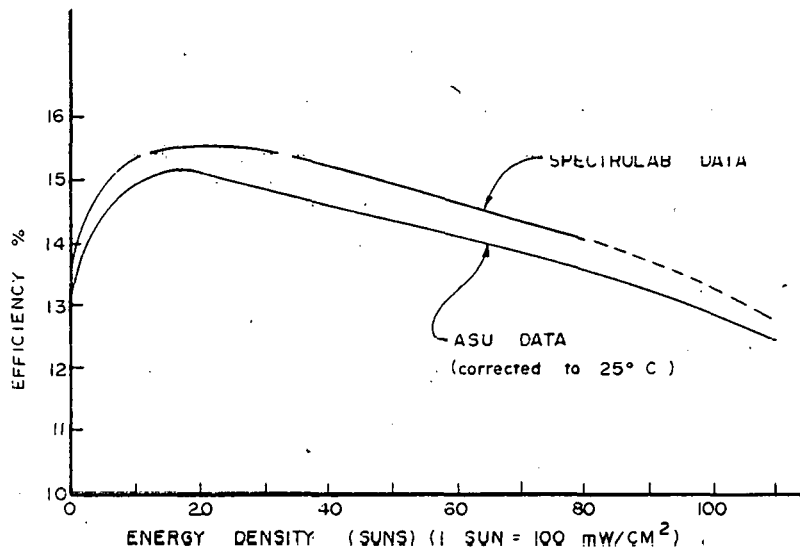

Fig. 24. Comparison of the temperature corrected data on similar cells tested at Spectrolab and at ASU.

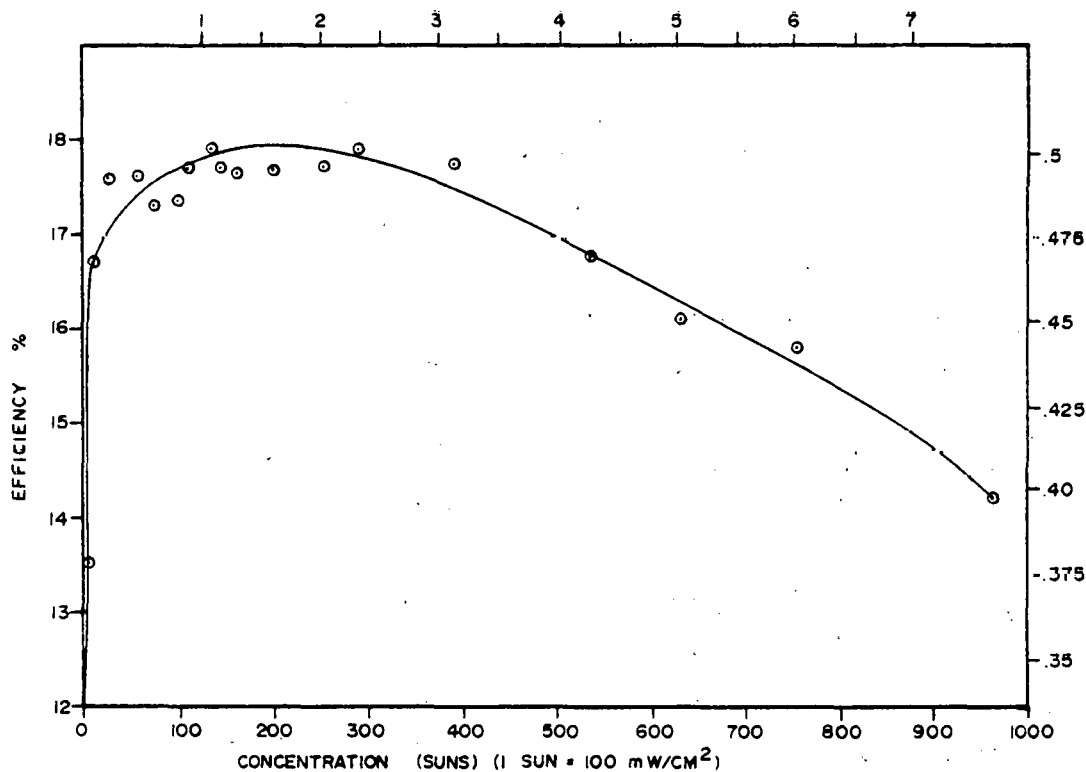

Fig. 25. The measured efficiency of the RCA silicon cell obtained from Sandia using the short circuit current for the determination of concentration ratio. All data was taken at 25°C+6°C (except the 960 point was at 41°C) and plotted after corrected to 25°C. The efficiency calculation used the entire area of the cell minus the area of the ohmic around the outside of the cell.

Figure 25 shows the efficiency performance of an RCA cell tested at ASU. These RCA silicon concentration cells are 0.25 X 0.25 inches square but with ohmics at the four corners are such that the active area of the cell was a .533 cm diameter circle. This cell was mounted by RCA onto a transistor base substrate. The one sun efficiency of this cell was 13.5%. The cell's peak efficiency was approximately 17.8% at 250 suns. The efficiency of the cell remains above the one sun efficiency level after 1000 suns concentration.

Gallium arsenide cells are of special interest for concentration applications due to their high efficiencies and their tolerance of higher temperatures. Figure 26 shows some I-V curves from Varian Associates taken on one of their gallium arsenide cells. A somewhat similar cell from Varian Associates tested at ASU gave the performance seen in Fig. 27. The one sun efficiency at 25°C was 17.6%. The peak efficiency was at 21.7% at less than 50 suns. This cell showed the efficiency dropping at 1000 suns to approximately 14%. Typical GaAs concentration cells show peaking at much higher concentration ratios. The plot of open circuit voltage as a function of short circuit current showed a decrease in voltage at the higher concentration levels indicating that perhaps the effective temperature of the cell was higher than the monitored temperature at the back of the cell. A more effective cooling technique might result in much higher efficiencies indicated at the higher concentrations. Figure 28 shows the linear decrease of open circuit voltage with temperature for concentrations up to about 150 suns. One should note that the temperature coefficient appears to decrease as the concentration increases. At 1000 suns the slope of the curve decreased to -1.18 mv per degree C.

A number of photovoltaic concentrator modules have recently been built and are starting to be tested. Very little of the data has been reported on these modules. Figures 29 and 30 show the 1 kW array built and tested by Sandia Laboratories (32). Figures 31 and 32 show the nominal 1 kW system built and tested by Varian Associates (36). Figure 33 shows the modules delivered to Sandia by RCA Laboratories that involve lenses which provide concentration of about 300 suns on the RCA cells. The overall system efficiency of this unit of electrical output to energy incident on the lens is about 10% (37). Figure 34 shows the CPC solar cell concentration array built by Argonne National Laboratories and delivered to Sandia for testing. Again the overall efficiency of this system is about 10%. Figure 35 shows the I-V curve for the entire array showing the fairly sharp knee of the curve (38).

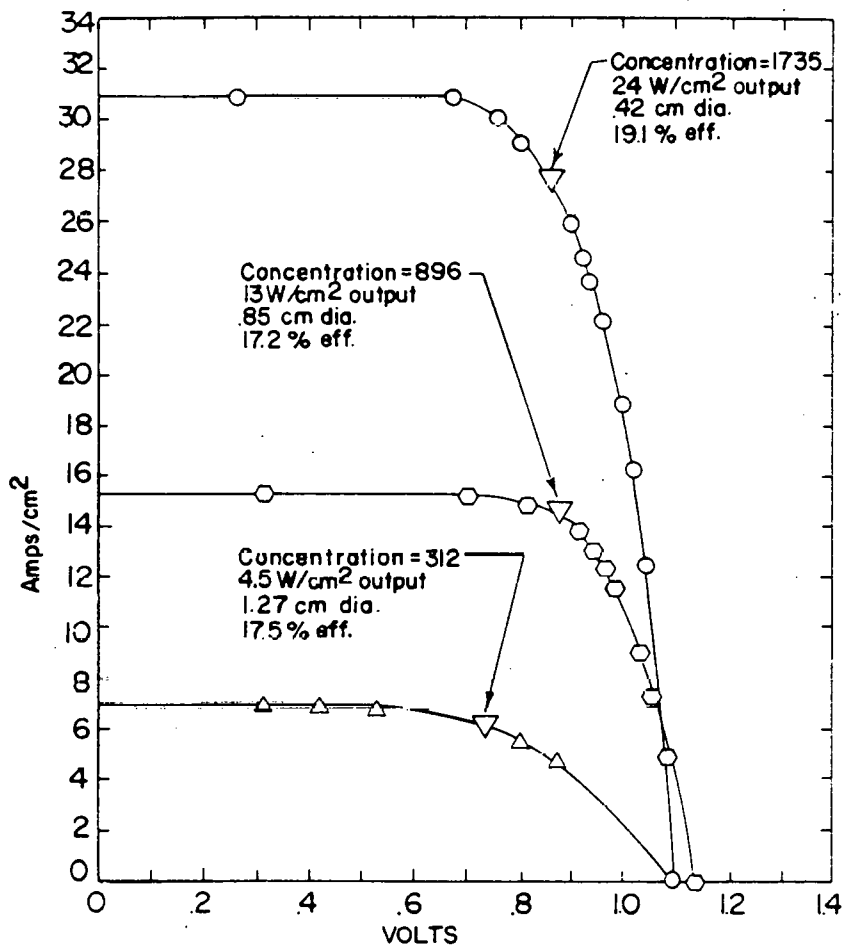

Fig. 26. Current-voltage curves for a GaAs concentration cell made and tested by Varian Assoc. (26)

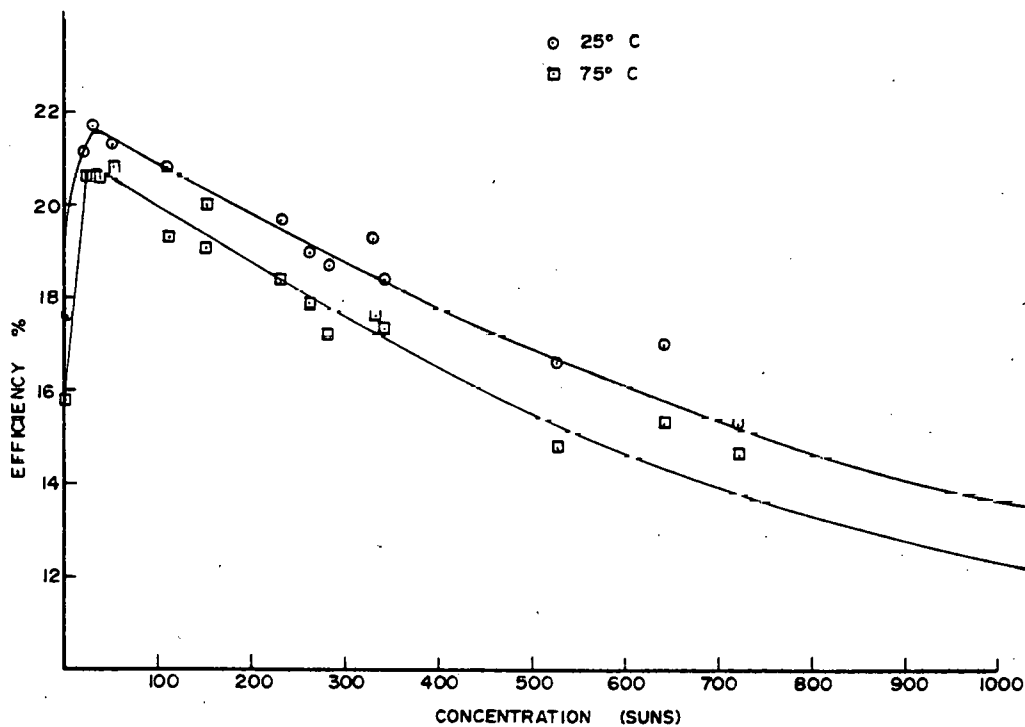

Fig. 27. Data on the Varian GaAs cell (10-11-77RF1). The circled data points were taken at a cell temperature of 25°C and the squared points were taken at 75°C. The solid lines are approximate fit curves.

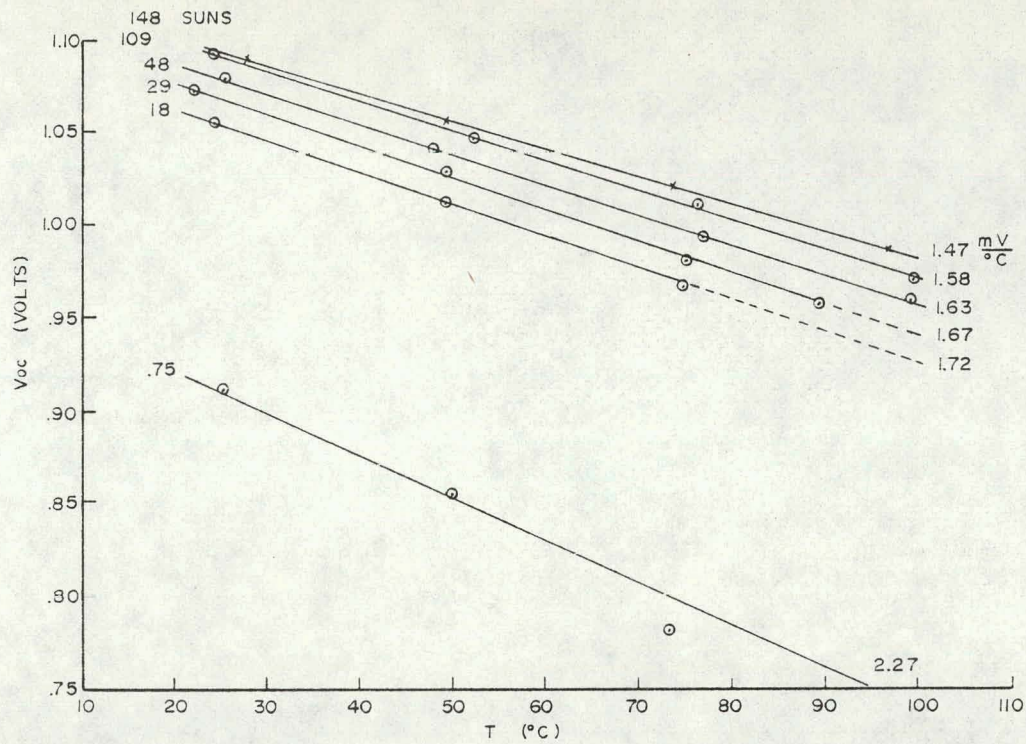

Fig. 2.28. The open circuit voltage for the Varian GaAl-As cell (10-11-77J RF1) as a function of temperature up to about 150 suns. The voltage temperature coefficient decreases considerably as intensity increases.

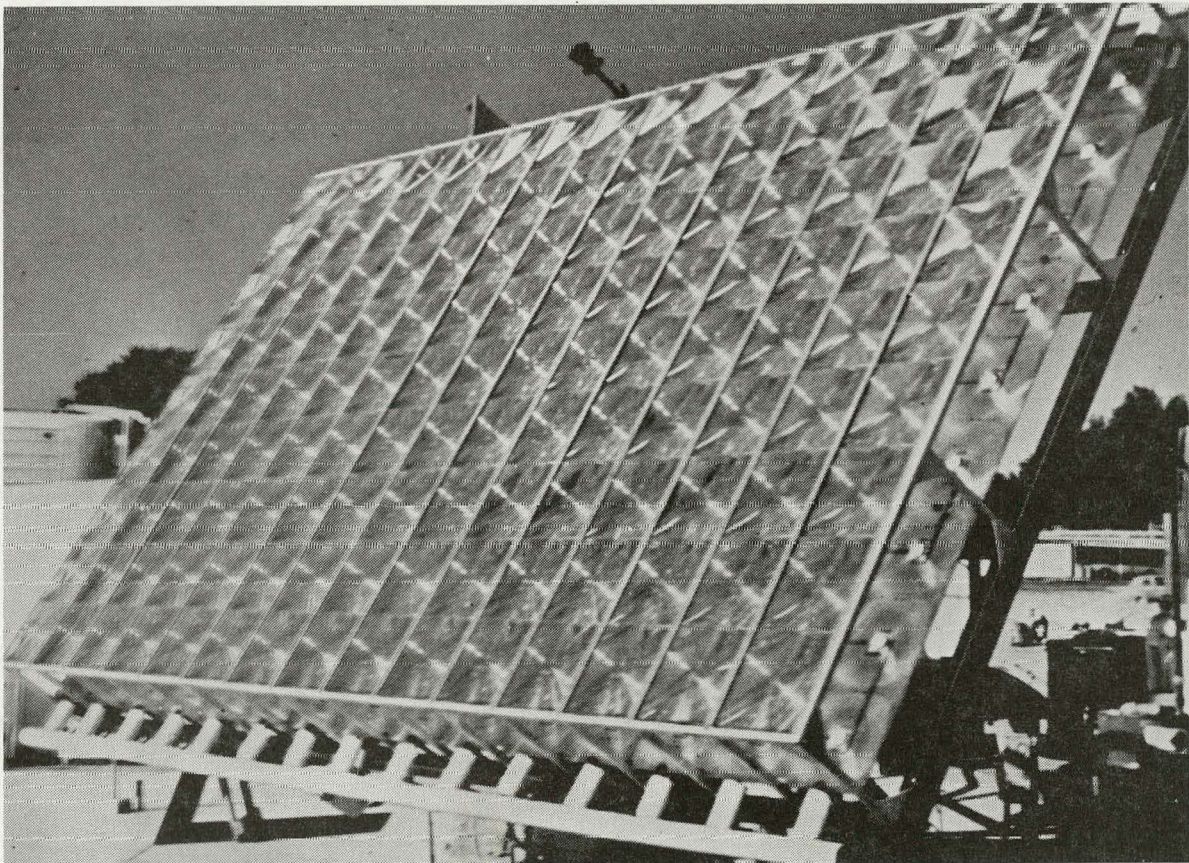

Fig. 29. The 1 kW peak photovoltaic concentration system utilizing circular Fresnel lenses built by Sandia Labs.

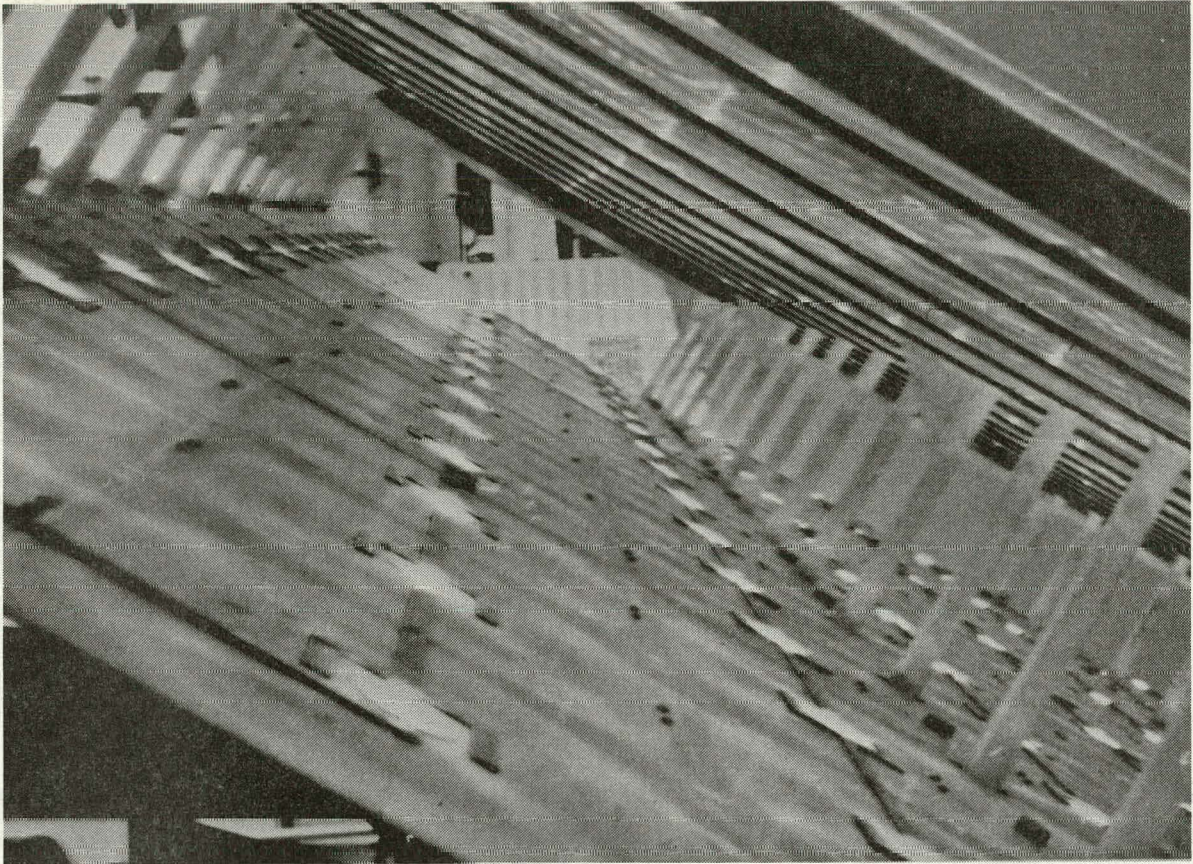

Fig. 30. Close up of the Solar cells in the Sandia 1 kW system

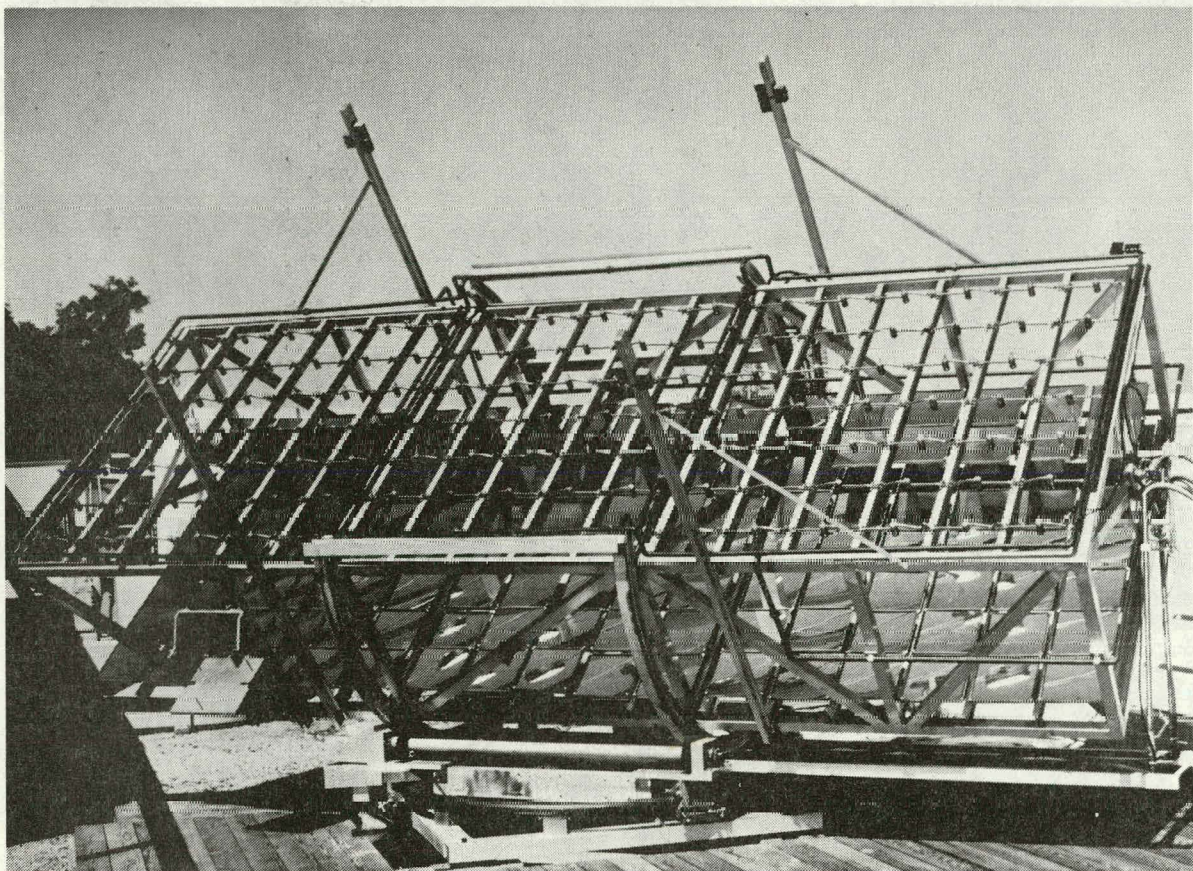

Fig. 31. Nominal 1kW Photovoltaic Concentration system built and tested by Varian.

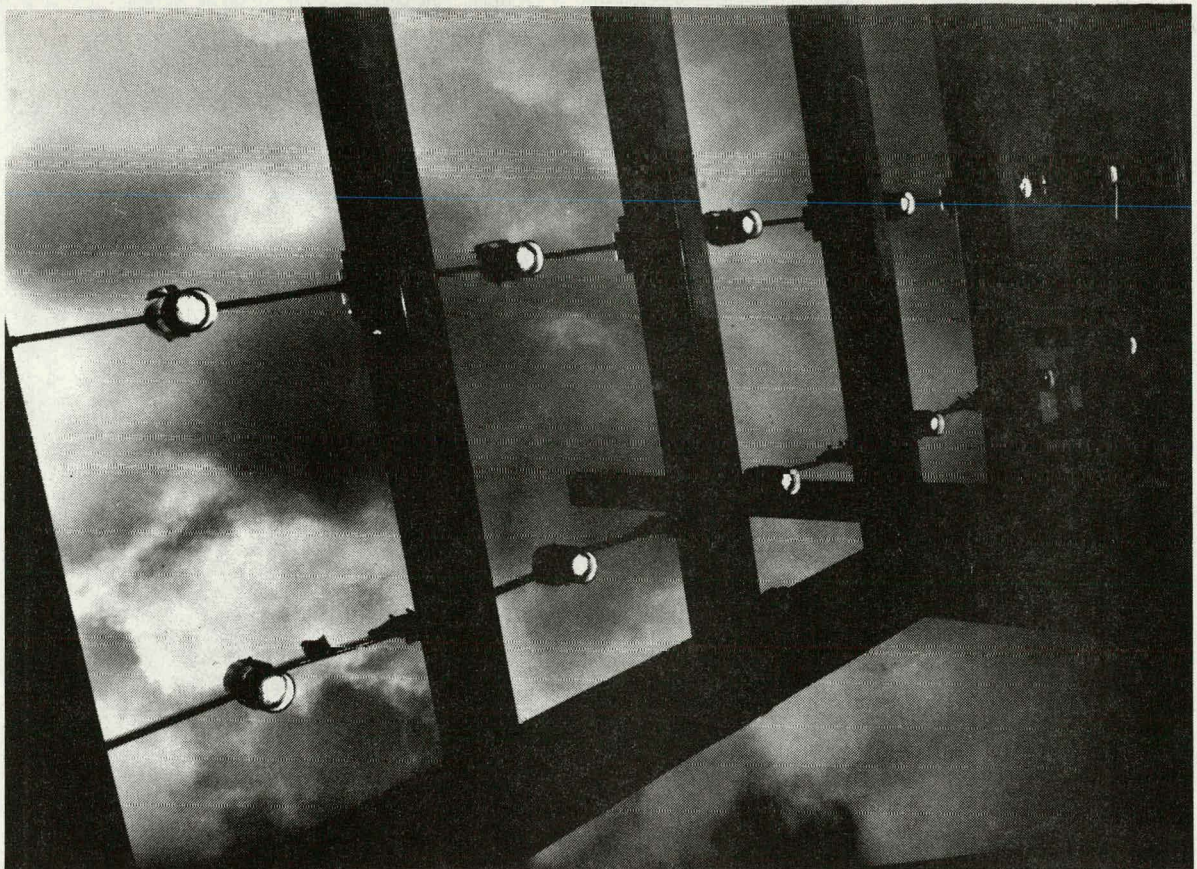
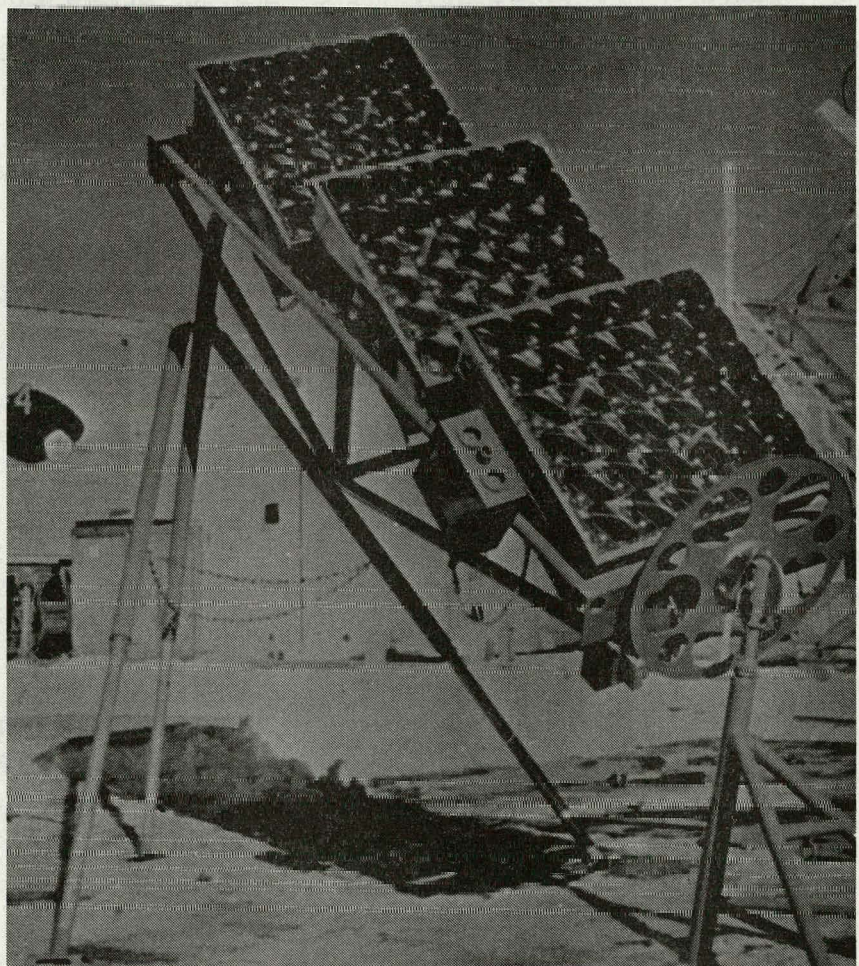

Fig. 32. Close up of the GaAs cells in the Varian, 1 kW system.

Fig. 33 Three RCA modules of lenses which provide a concentration of about 300 suns onto silicon cells.



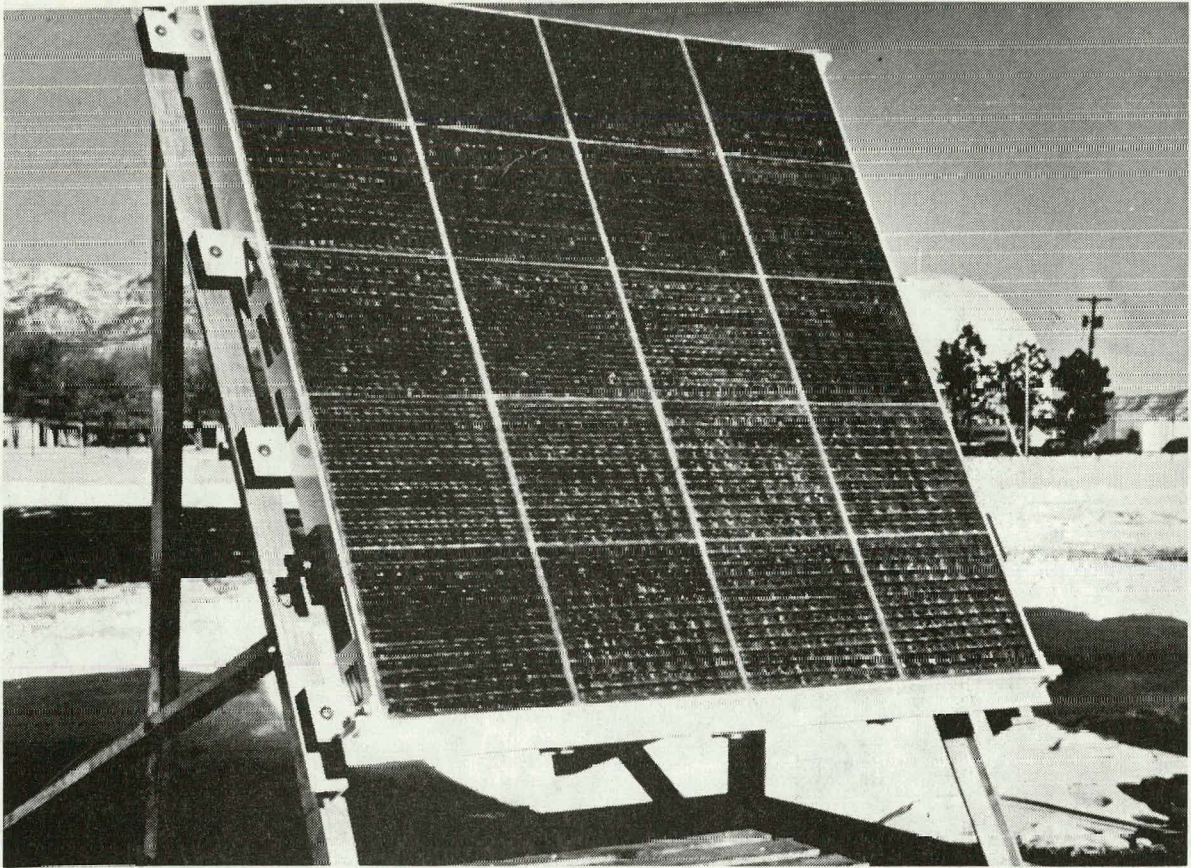

Fig. 34. A photovoltaic concentration panel utilizing compound parabolic concentrators (CPC) designed by Argonne Labs.

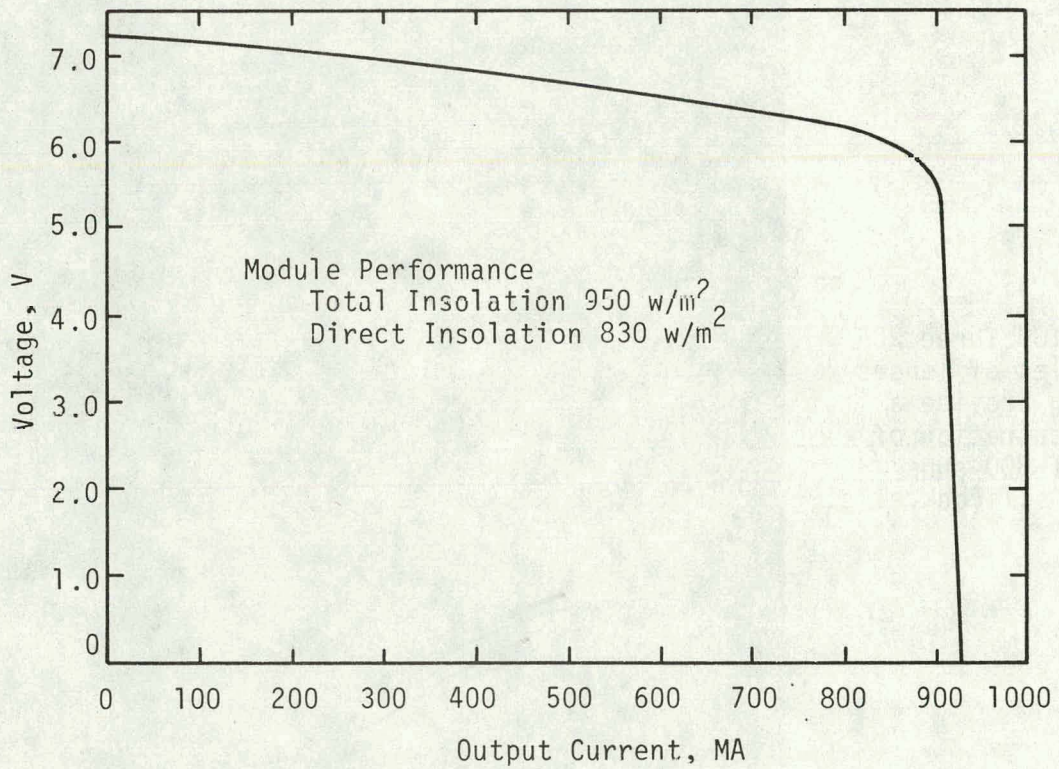

Fig. 35. The current voltage characteristics of the Argonne panel shown in Fig. 34.

Sandia Laboratories in Albuquerque, NM have the program responsibility to DOE for the development of concentrator photovoltaic systems. They are in the process of acquiring several modular units of photovoltaic concentrator systems. Table 4 is a listing of the types of modular arrays being acquired with the corresponding rated peak output and supplier indicated. One of the uniqueness of photovoltaic converters is that their efficiency is essentially independent of the size of the system, therefore, photovoltaics can be combined with any concentrator configuration in a modular type of way such that the testing of a module can be representative of any size system made from that basic module.

Sandia has contracted to have three separate 10 kW photovoltaic systems designed and built. Figure 36 shows the configuration being built by Martin Marietta. The upper left hand corner shows what an individual module of this system would look like. It utilizes circular fresnel lenses with an approximately 40 suns of concentration. It tracks the sun in two axes and is passively cooled. Each of these main arrays would consist of 34 detachable modules mounted on the support tube. Each module assembly encloses four silicon solar cells made by OCLI, mounted with a single Fresnel lens containing four focal point focusing patterns. The module size is 1 ft X 4 ft. The complete array is 42 ft long, 9 ft high and contains all the necessary drive mechanisms to control the electronics. This individual array is designed to have a peak power of 2.3 kW being delivered at 114 volts. Its overall efficiency is about 9%. Figure 37 shows test results for one of these modules.

A separate 10 kW concentrator system is being designed and built by Spectrolab in Sylmar, CA. The optics in this system consist of a reflective parabolic trough with a compound elliptical secondary reflector and absorber element. The modules are oriented on a carousel for azimuth tracking and are ganged together in a venetian blind approach for elevation tracking. A geometrical concentration of 25 is used. The design utilizes passive cooling which provides a nominal cell operating temperature of less than 74°C. The entire carousel concept can be seen in Fig. 38. The specifications for this system are shown in Table 5.

Figure 39 shows the conceptual design for a 10 kW system by the AAI Corp. of Baltimore, MD. This system utilizes a 200-1 optical concentrator with cells being provided by Solarex, Corp. It utilizes a fluid loop heat

TABLE 4

CONCENTRATOR ARRAY TESTING

ARRAY TYPE	RATED OUTPUT (PEAK)	SUPPLIER	TEST PERIOD
NON-TRACKING REFLECTIVE CPC	100 W	ARGONNE NATIONAL LABS	12 MO
NON-TRACKING DIELECTRIC CPC	100 W	ARGONNE NATIONAL LABS	13 MO
TWO-AXIS HIGH CONCENTRATION REFRACTIVE	100 W (TWO ARRAYS)	RCA	12 MO
TWO-AXIS HIGH CONCENTRATION REFRACTIVE	300 W	RCA	7 MO
TWO-AXIS LOW CONCENTRATION REFLECTIVE	50 W	SUN-TRAC	11 MO
TWO-AXIS FRESNEL CONCENTRATOR ARRAY	1000 W	SANDIA LABS	12 MO
TWO-AXIS FRESNEL CONCENTRATOR MODULE	34 W	MARTIN-MARIETTA	3 MO

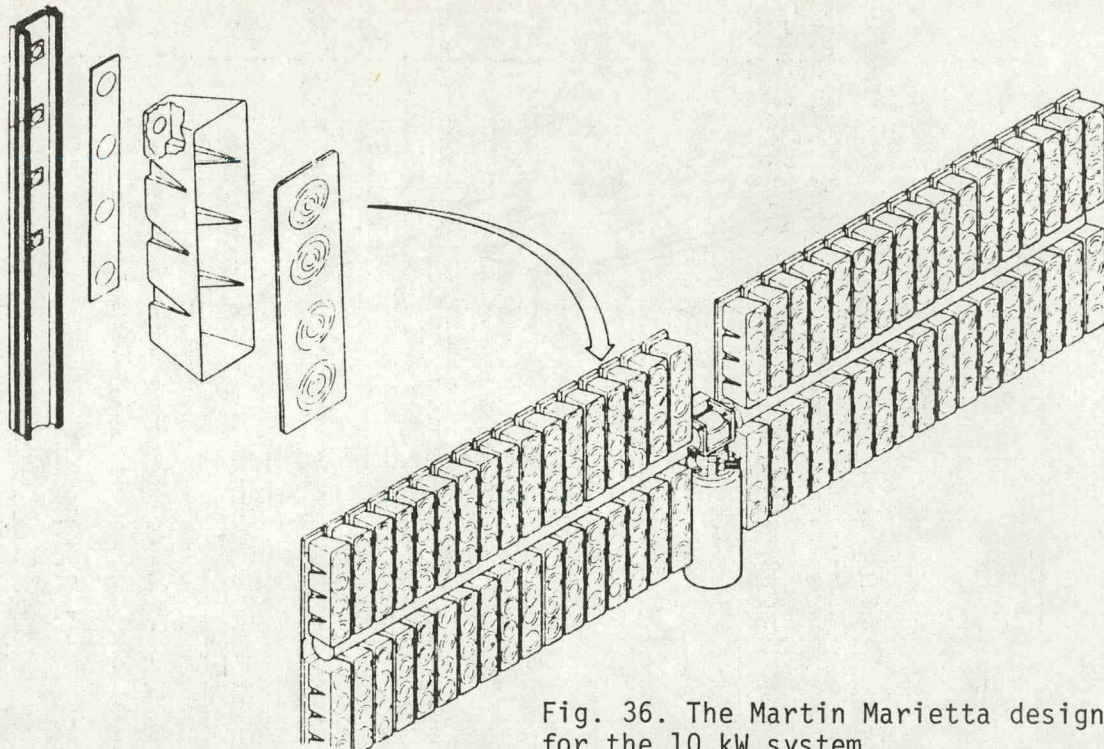

Fig. 36. The Martin Marietta design for the 10 kW system.

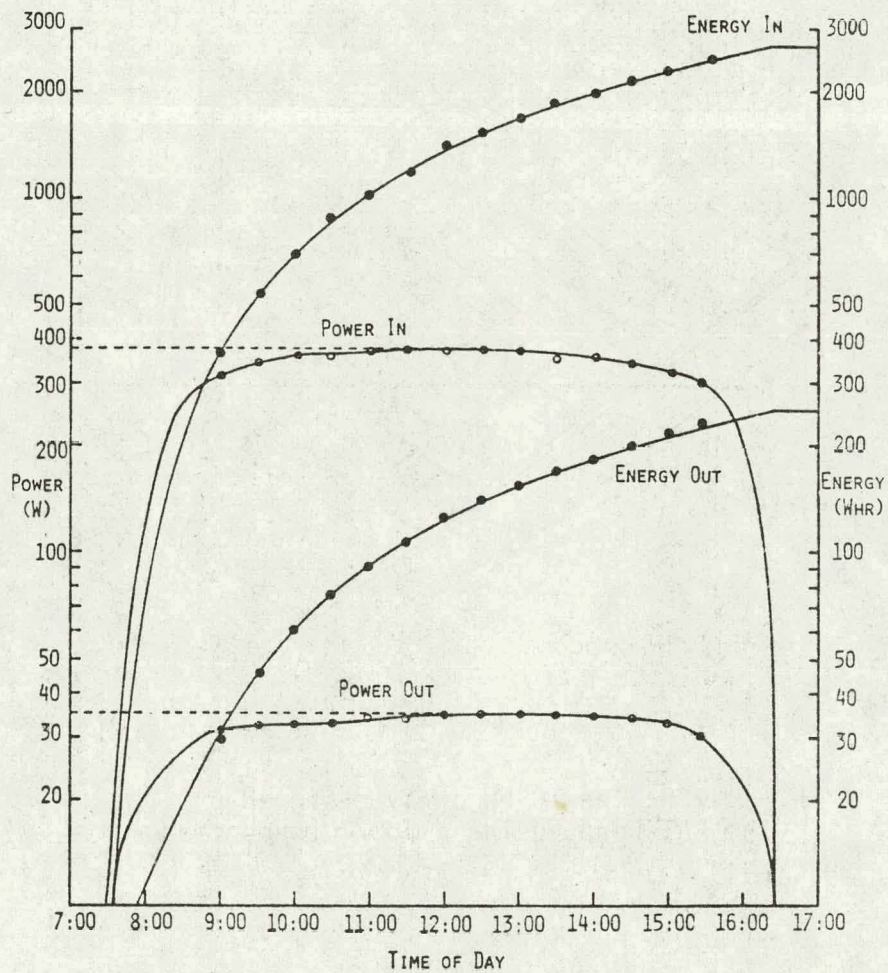

Fig. 37. Martin Marietta module performance test results.

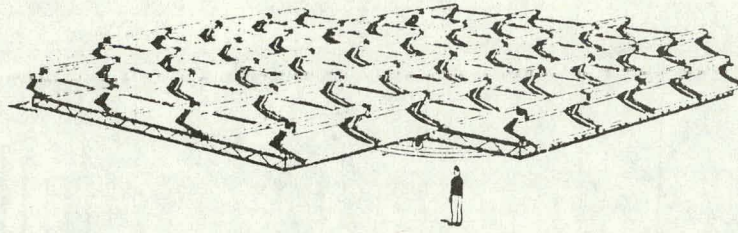

Fig. 38. The 10 kW steerable solar concentrator designed by Spectrolab.

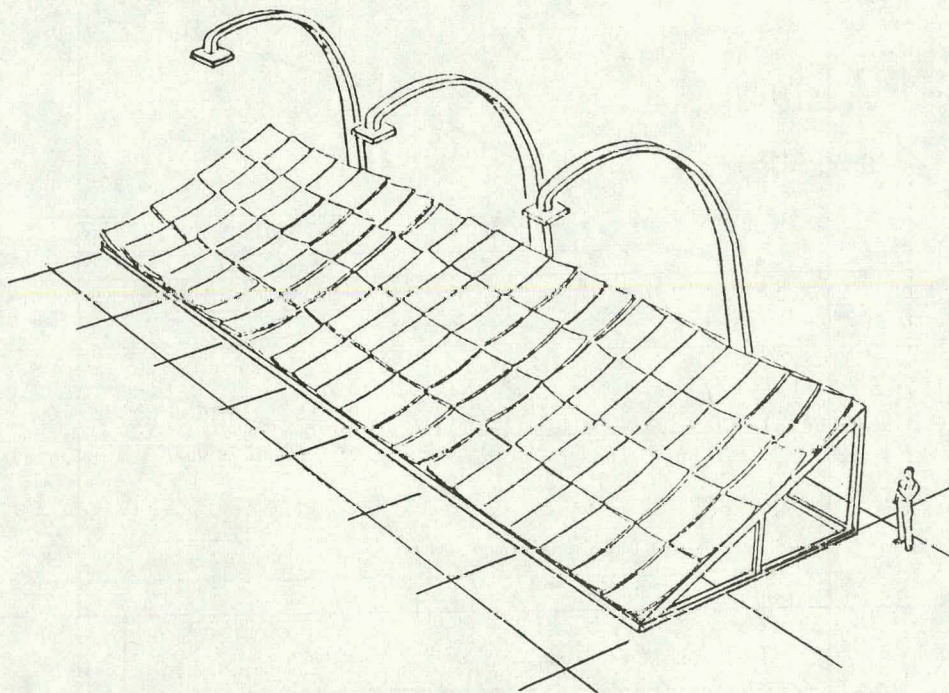

Fig. 39. The 10 kW array designed by the AAI Corp. using a 200/1 concentrator.

transfer system for cooling the cells. The 200-1 system consists of a mounting frame, second surface glass mirrors, a receiver photovoltaic cell assembly and a two axes solar tracking system. The mirrors are relatively small (3 ft. X 5 ft) shallow parabolic mirrors mounted on a fixed frame to minimize structural mounting problems.

There is a large photovoltaic concentration system being designed for installation at the Mississippi County Community College in Arkansas. This system will produce a peak electrical output of 362 kW. It is scheduled for opening August 15, 1979. The concentration system is a linear fresnel reflector made by Honeywell. Each module is 16 ft long and provides a concentration of 20 suns onto the silicon solar cells being provided by Solarex, Corp. The cells will be actively cooled with the waste heat being utilized in the building structure. These cells will have an operating efficiency of over 15%.

Developing Technology for Photovoltaic Concentrator Systems

There are a large number of different approaches being pursued in the national photovoltaic concentrator program. Many of these are the necessary design innovations and test and demonstration programs required for the maturing of any technical field. The major contribution to the advancement of photovoltaic concentration systems will, of course, be made in the cost reduction of electrical power. There are, however, some technical concepts being pursued which could contribute significantly to the future of photovoltaic concentration systems. The main developmental effort is in the production of cell systems that may be capable of 30-35% conversion efficiencies.

One major advantage of photovoltaic concentrator systems is that at high concentrations the costs of the solar cells are very small compared with other components of the system. However, the cost per electrical output of the entire system is inversely proportional to the efficiency of the solar cells. Therefore it could economically pay to have high efficiency solar cells even if their costs are high. It is quite conceivable that for concentration systems a cell configuration seen either in Fig. 40 or 41 could greatly increase the overall efficiency of the converter. Variations of these two concepts have been recently studied by a number of investigators (39-49) These techniques are used to try to utilize a greater percentage of the solar spectrum than do present day, one junction solar cells. If two, or more, different band gap material cells are used together then efficiencies of

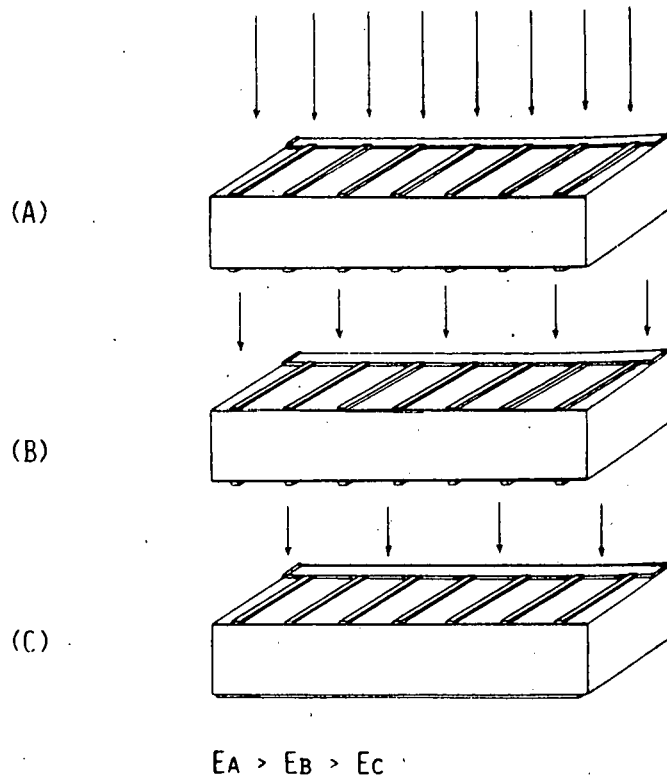

Fig. 40. Optical series operation of solar cells to utilize a greater percentage of the solar spectrum (39).

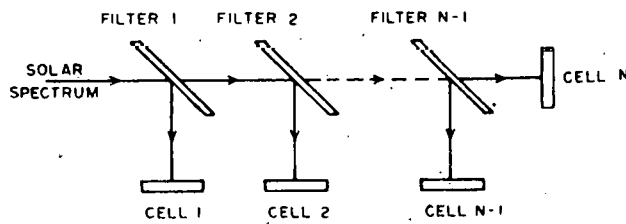

Fig. 41. Multiple cell converter system incorporating filters to separate spectrum. (39)

30-40% can be calculated as possible. If the cells are put in optical series then the higher band gap material would go first with the transmitted light incident on subsequent lower gap material cells. An alternate way to stacking the cells optically is to use selective mirrors to divide the solar spectrum into energy bands that would be exposed to selected band gap solar cells. The latter approach has the advantage from the design point of view because the problems associated with each cell and the cooling of it could be solved independent of the other components of the system. The most desired configuration, if technically feasible, would be to combine all of the different band gap materials into one composite structure.

In addition to making cells that utilize different parts of the solar spectrum, one could use the approach of converting the frequencies in the solar spectrum to one that a solar cell could convert more efficiently. A frequency converter concept that was investigated some years ago by Purdue University through the sponsorship of the US Army, and more recently by Stanford University through the sponsorship of EPRI, is one called thermal photovoltaics. This is a concept by which sunlight is concentrated into a thermal absorber which is designed to get sufficiently hot that it radiates its energy as a black body radiation spectrum more in compliance with the spectral response of the cell than is the solar spectrum. This usually requires very high temperatures implying solar concentrations of about 10,000 suns. The cells could be designed for the black body radiation spectrum and a number of advantages could be derived. For example, an infrared reflector could be put on the back of a silicon cell which would reflect normally wasted energy back to the radiation source for recycling. Calculations on these systems predict efficiencies in the 30-40% range.

Another frequency converter-concentrator being pursued utilizes a flat plastic sheet which contains absorbing dyes that will re-emit absorbed energy in a limited spectrum. This re-emission from inside the sheet of plastic could be optically trapped by the critical angle of the plastic such that concentration would result at the edge of the plastic sheet. A solar cell could be mounted at the edge which responds to the emission frequency of the dye material. The technical and economic feasibility of these luminescent solar concentrators is being investigated by Owens-Illinois of Toledo, OH.

Cost Goals and Estimates

The objective of the general photovoltaic program of DOE is to ensure that photovoltaic systems play a significant role in the nation's energy supply. They have a goal of providing 50,000 MW of installed electrical generating capacity by the year 2000. The near term goal (1982) is to bring the cost of photovoltaic systems down to \$2/peak watt array price. By 1986 it is hoped that the array price will be 50¢/peak watt. This should correspond to 50-80 mills per kW hour. The far term goal (2000) is to achieve 10-30¢/peak watt for the array price. All of the price goals are quoted in 1975 dollars.

The photovoltaic concentrator technology development project being carried out by Sandia Laboratories for DOE is one option being pursued to obtain the general goals stated above. While it is clear that concentrating arrays offer significant potential for near term array cost reduction, the overall project goals are also aimed at developing arrays which are cost competitive in the long term. The DOE budget authority for this concentrator technology development program in FY 78 was \$3.3 million. In FY 79 it is anticipated that a large increase will occur in this program. Table 6 shows the near term cost goals set by Sandia Laboratories for each of the components in the concentration systems. Figure 42 shows how these cost goals relate to projected experience in concentrator prices quoted recently. Table 7 gives the major conclusions from the photovoltaic concentrator program to date with projected cost numbers.

Table 8 shows the advantage in economics gained by concentration. This table was compiled by AAI, Corp. and is what led them to their system concept utilizing a 200-1 concentration ratio. The first part of the table gives the estimated cost under a very high production schedule and would result in a total cost of \$1.51/peak watt. At more moderate production rates, indicated in the bottom part of the table, the cost of the 200-1 system would be \$2.58/peak watt.

The Sun Trac Corp. of Wheeling, IL is perhaps the only company which commercially offers photovoltaic concentration systems at this time. They contend that they can build a photovoltaic power module ready for production in 1978 and at the sales price of less than \$5/peak watt with the volume of 500 peak kW. Each of these modules would have a rating of about 450 peak watts. Their module consists of a number of conical CPC concentrators

TABLE 6
CONCENTRATOR TECHNOLOGY 5-YEAR GOALS
(1975 dollars)

<u>Technology Area</u>	<u>Units</u>	<u>Fiscal Year</u>				
		<u>78</u>	<u>79</u>	<u>80</u>	<u>81</u>	<u>82</u>
1. Silicon Concentrator Cell Subsystems						
Technical Feasibility:	Efficiency, %	16		18		20
	\$/m ²	2,000		1,500		500
Production Technology:	Efficiency, %	13.5	15	16	17	18
	\$/m ²	12,000	7,000	4,000	2,500	2,000
2. Concentrator Subsystems						
Technical Feasibility:	Efficiency, %	80		83		85
	\$/m ²	210		130		70
Production Technology:	Efficiency, %	70	75	80	82	83
	\$/m ²	1000	400	270	230	200
	Volume, m ²	250	4,500	12,000	14,000	23,000
3. Array Subsystems						
Technical Feasibility:	Concentration Ratio	50		50		30
	Array Efficiency	12.8		15		17
	\$/m ²	250		160		85
	\$/W _p	<u>2.00</u>		<u>1.00</u>		<u>0.50</u>
Production Technology:	Concentration Ratio	30	40	50	50	50
	Array Efficiency	9.4	11.2	12.8	14	15
	Volume, kW _p	25	500	1,500	2,000	3,500
	\$/m ²	1,400	575	350	280	240
	\$/W ₀	<u>15</u>	<u>5.00</u>	<u>2.75</u>	<u>2.00</u>	<u>1.60</u>

EQUIVALENT EXPERIENCE (PEAK POWER)

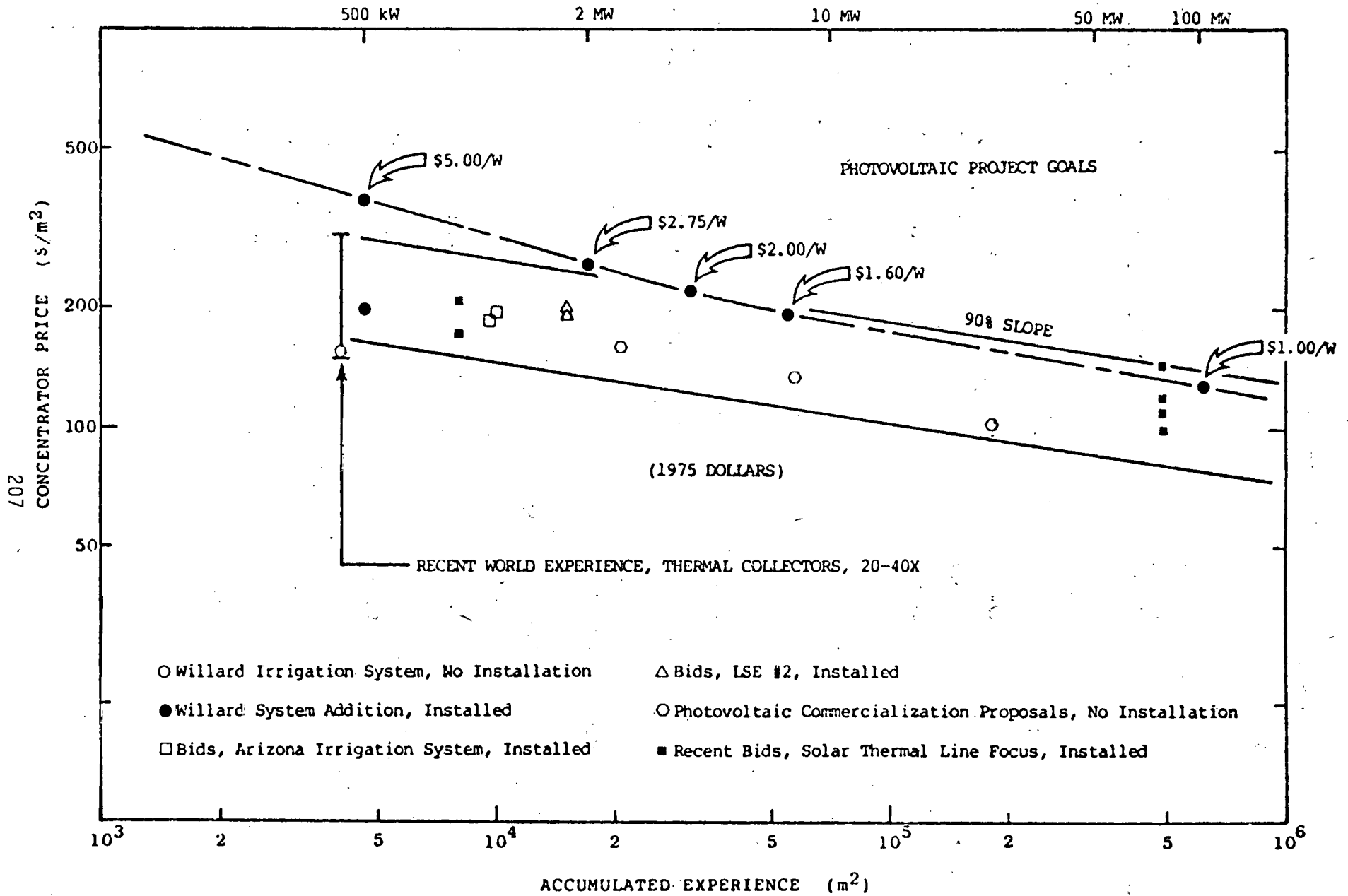

Fig. 42. The projected cost of photovoltaic concentration systems based on contractors quotes and bids for concentrators as a function of accumulated volume of production. Compiled by Sandia Laboratories.

TABLE 7
SUMMARY OF MAJOR CONCLUSIONS

- BASED ON THE MOST LIKELY PROGRAM STRATEGY,
\$2/W CAN BE ACHIEVED IN 1981
- \$2/W CAN BE ACHIEVED AT AN ACCUMULATED EXPERIENCE OF
APPROXIMATELY 4MW_p
- NO CELL TECHNOLOGY BREAKTHROUGHS ARE REQUIRED TO REACH AN
ARRAY PRICE OF \$1/W
- A \$2/W SOLAR CELL TECHNOLOGY (UNCONCENTRATED) IS REQUIRED TO
ACHIEVE \$0.50/W
- THE THRESHOLD FOR ESTABLISHING A PRICE--
EXPERIENCE CURVE IS 100-500 kW_p

TABLE 8
ADVANTAGE IN ECONOMICS GAINED BY CONCENTRATION

1978 Simplified Cost Comparison
Effect of Power Ratio on Cost of 10 KW System

Power Ratio	1/1	20/1	40/1	200/1
Area - Sq. Ft.	1300	1350	1400	1500
Reflector \$ @ \$8/sq. ft.	0	10,800	11,200	12,000
Number of Cells	315,000	16,400	8,502	1,821
Cost per Cell (\$) (Tooling Amortized)	1.00	1.20	1.40	1.70
Cost of Cells (\$)	315,000	19,677	11,903	3,096
Total Cost (\$)	315,000	30,477	23,103	15,096

HIGH PRODUCTION RATE

Power Ratio	1/1	20/1	40/1	200/1
Area - Sq. Ft.	1300	1350	1400	1500
Reflector \$ @ \$8/sq. ft.	--	12,150	12,600	13,500
Number of Cells	315,000	16,400	8,502	1,821
Cost per Cell (\$) (Tooling Amortized)	4.00	4.80	5.60	6.30
Cost of Cells (\$)	1,260,000	78,720	47,611	12,333
Total Cost (\$)	1,260,000	90,870	60,211	25,833

MODERATE PRODUCTION RATE

providing a 50-70 sun concentration onto silicon cells. These are mounted in a transparent weather-tight sphere that minimizes wind loading and corrosive environmental effects. Table 9 gives the 1978 costs for solar cells quoted to Sun Trac Corp. from three different solar cell manufacturers.

Table 10 shows the cost of various components of a solar concentration system compiled by Sun Trac showing the breakdown of DOE projections, a system costed out by Boeing Engineering, and the breakdown of their estimated costs.

It should be clear from the predictions of the price of electricity from photovoltaic concentration systems given herein, that these systems could become competitive for certain applications in the near future. They will be especially competitive where low power level systems are needed and may even compete with solar thermal power systems at all power levels. Like most other solar systems, the system costs are dominated by the cost of the surface which first intercepts the sunlight. Therefore photovoltaic concentrator systems are inherently limited by the cost of the concentrator. The main advantage that photovoltaic systems have over thermal systems is the greater flexibility to accommodate any low cost concentrator. They can be designed to operate very efficiently at any concentration level from one to about 1000 suns. A present day photovoltaic concentrator system would probably economically compete with any concentrator thermal system that is to deliver either electrical or mechanical power. The photovoltaic concentrator systems of course have all the drawbacks of other concentration systems. These drawbacks include the reliance primarily on direct insolation and the more complex system implied if there is a need for tracking.

Major Problems

The major problem associated with photovoltaic concentrator systems is, of course, system cost. All of the figures quoted in this paper and in the goals of the DOE program are for cost of the photovoltaic array system at the factory outlet. They do not include installation or other operating system component costs such as energy storage.

Shadowing of the photovoltaic array is perhaps not a major problem but it is unique to the photovoltaic concentration system. The problem arises since the systems are typically designed with several small cells that are in electrical series connection. This means if a shadow, for example from a structural component of the concentrator, is cast on one cell in the cell

TABLE 9
SOLAR CELL DATA

COSTS ARE STATED FOR 1978 \$	COMPANY A	COMPANY B	COMPANY C
2 INCH DIAMETER ACTIVE AREA - COST EACH CELL			
QUANTITY			
100	\$ 51.00	\$ 54.00	\$ 114.00
1,000	36.00	-	38.00
40,000	24.00	13.00	20.00
FOR 400KW POWER CELL COST \$ PER WATT ≈	\$ 2.40	\$ 1.30	\$ 2.00
EFFICIENCY	%	%	%
50X @ 28°C.			
MINIMUM	11.5	-	13.0
AVERAGE	13.5	14.5	-
0.9 INCH DIAMETER ACTIVE AREA - COST EACH CELL			
QUANTITY			
100	\$ 15.00	\$ 13.50	\$ 28.00
1,000	11.00	-	8.50
50,000 up	7.00	3.50	5.50
FOR 400KW POWER CELL COST \$ PER WATT ≈	\$ 2.69	\$ 1.40	\$ 2.11
EFFICIENCY	%	%	%
50X @ 28°C			
MINIMUM	-	-	13.0
AVERAGE	14.0	15.0	-
0.3 INCH DIAMETER ACTIVE AREA - COST EACH CELL			
QUANTITY 500,000	-	\$.70	\$.28
50X @ 28°C			
FOR 400KW POWER CELL COST \$ PER WATT ≈	-	\$ 2.00	\$.80
0.25 INCH DIAMETER ACTIVE AREA - COST EACH CELL			
QUANTITY 500,000	-	-	\$.195
70X @ 28°C.			
CELL COST \$ PER WATT ≈	-	-	\$.60

TABLE 10
SYSTEM COST COMPARISONS

<u>Item</u>	<u>D.O.E. Breakdown \$ per KW</u>	<u>Ref. No. 1*</u>	<u>Proposed Sun Trac System</u>
Silicon Solar Cell and Assembly (including cooling)	\$400.		
Solar Cells		\$2000.	\$277.
Power Collection Circuit		800.	44.
Cooling		1416.	88. (1)
Solar Cell In-House Cost		1332.	92.
Cables & Wiring		Not Specified	11.
Concentrator Optics	\$500.		
Fresnel Lens		\$1370.	N/A
Sun Trac Concentrator Matrix		N/A	44.
Array Structure & Tracking	\$600.		
Structure Material		\$739.	36. (1)
Structure Fab. Labor		774.	32.
Tracking Electronics		1000.	15.
Gimbals & Motors		470.	50.
Sun Trac Sphere		None	200.
Support Structure		250.	38.
Assembly & Testing	<u>\$500.</u>	<u>1000.</u>	<u>60.</u>
Total Cost	\$2000.	\$11151.	\$927.
Net watts (peak)	1000	3828.5	442.6
Cost \$ per peak watt	\$2.	\$2.91	\$2.09

* Ref. No. 1 D. K. Zimmerman and C. J. Bishop "Concentrating Photovoltaic Solar Array (CPSA) Conceptual Design Study" Final Report, May, 1977 prepared for Sandia Laboratories, Contract No. 05-4467, by Boeing Engineering and Construction, Document D 277-10045-1

(1) Sun Trac Cooling System is an integral and major part of the array structure.

string, then the electrical output for the whole string is lost. If not designed for, this could reduce the total system output by a large percentage. An additional shadowing problem might be the imposed voltage across the shadowed cell which could create either electrical or thermal problems in the array. The shadowing condition also has implications on the placement of individual modules in a concentration field. If one module would shadow part of another module during any part of the day or year it is conceivable that the entire output of the partially shadowed module would go to zero. These problems have been studied and do not appear to be major problems other than requiring engineering ingenuity (48,49).

THIS PAGE INTENTIONALLY LEFT BLANK

References

1. P. Schoffer and C. Pfeiffer, "Performance of Photovoltaic Cell at High Radiation Levels," *Trans. ASME*, 85A, p. 208, 1963
2. E. L. Ralph, P. Berman, "Silicon Cells for Use in Concentrated Sunlight," *Proc. 17th Power Sources Conference*, May 1963
3. P. Berman, E. L. Ralph, "Improved Solar Cells for Use in Concentrated Sunlight," *Proc. 18th Power Sources Conference*, May 1964
4. W. A. Beckman, et.al., "Design Considerations for a 50-Watt Photovoltaic Power System Using Concentrated Solar Energy," *Solar Energy*, Vol. 10, No. 3, 1966
5. E. L. Ralph, "Use of Concentrated Sunlight with Solar Cells for Terrestrial Applications," *Solar Energy*, Vol. 10, No. 2, 1966
6. E. L. Ralph, "A Plan to Utilize Solar Energy as an Electric Power Source," *Conf. Record #70C32ED 8th IEEE Photovoltaic Specialist Conf.*, 1970.
7. *Terrestrial Photovoltaic Power Systems With Sunlight Concentration, 1974 Annual Progress Report*, NSF/RANN/SE/GI-418941/RR/74/4, Arizona State University and Spectrolab, Inc., Jan 1975
8. C.E. Backus, "Photovoltaic Conversion," Ch. 12, *Solar Energy Engineering*, Edited by A.A.M. Sayigh, Academic Press, Inc., 1977
9. J.J. Loferski, "Recent Research on Photovoltaic Solar Energy Converters," *Proc. IEEE*, 1963
10. M. Wolf, "A New Look at Silicon Solar Cell Performance," *Energy Conversion*, Vol. 11, Jun 1971
11. D.T. O'Donnell, Arizona State University, personal communication
12. J. G. Fossum, et al., "Silicon Solar Cell Designs Based on Physical Behavior in Concentrated Sunlight," *Proc. Photovoltaic Concentrator Workshop*, Scottsdale, AZ, May 1977
13. T.B.S. Chadda and M. Wolf, *Conf. Rec. 9th IEEE Photovoltaic Specialists Conference*, Silver Spring, 1972, p. 87.
14. W. P. Rahilly, *Conf. Rec. 9th IEEE Photovoltaic Specialist Conference*, Silver Spring, 1972, p. 44.
15. A. Gover and P. Stella, *IEEE Trans. El. Dev.*, ED-21, 351, 1974
16. B.L. Sater, et al., *Conf. Rec. 11th IEEE Photovoltaic Specialist Conference*, Scottsdale, May 1975, p. 356
17. B.L. Sater and C. Goradia, *Conf. Rec. 12th IEEE Photovoltaic Specialist Conference*, Baton Rouge, Nov 1976, p. 781

18. C. Goardia, et al., Conf. Rec. 12th IEEE Photovoltaic Specialist Conf., Baton Rouge, Nov 1976, p. 781.
19. C. Goardia and B. L. Sater, IEEE Trans. El. Dev., ED-24, 342, 1977.
20. T.T. Rule, et al., "The Testing of Specially Designed Silicon Solar Cells Under High Sunlight Illumination, 12th IEEE Photovoltaic Specialists Conference, Baton Rouge, Nov 1977, p. 744
21. M.D. Lammert and R. J. Schwartz, IEEE Trans. El. Dev. ED-24, 337, 1977.
22. R.J. Schwartz and M.D. Lammert, Tech. Digest, 1976 Intern. Electron Dev. Mtg., Washington, Dec 1975, p. 350.
23. H.J. Hovel, "The Use of Novel Materials and Devices for Solar Concentrating Systems," Photovoltaic Concentrator Systems Workshop, Scottsdale, AZ, May 1977
24. J. M. Woodall and H.J. Hovel, "High Efficiency $Ga_{1-x}As-GaAs$ Solar Cells," Appl. Phys. Lett. 21, 1972.
25. H.J. Hovel and J.M. Woodall, Conf. Rec. 10th IEEE Photovoltaic Specialist Conference, Palo Alto, Nov 1973, p. 25
26. L. W. James and R.L. Moon, Conf. Rec. 11th IEEE Phot. Spec. Conf., Scottsdale, AZ, May 1975, p. 402.
27. J. M. Woodall and H.J. Hovel, Appl. Phys. Lett. 30, 492, 1977.
28. Proceedings of the DOE Photovoltaic Concentrator Systems Workshop, May 24-26, 1977, Scottsdale, AZ (sponsored by Sandia Laboratories).
29. H. Brandhorst, et al., "Interim Solar Cell Testing Procedures for Terrestrial Application," NASA TM X71771, 1975.
30. Proceedings of the 2nd Annual Photovoltaic Measurements Workshop, Baton Rouge, LA, Nov 1976.
31. R.G. Ross, "Array and Component Testing," Proceedings of the ERDA Photovoltaic Concentrator Systems Workshop, Scottsdale, AZ, May 1977.
32. T.T. Rule, et al., "The Testing of Specially Designed Silicon Solar Cells Under High Sunlight Illumination," 12th Photovoltaic Specialist Conference, Baton Rouge, LA, Nov 1976.
33. D.T. O'Donnell, et al, "Performance of Silicon and Gallium Arsenide Concentration Cells," Proceedings 13th Photovoltaic Specialist Conference, Washington, June 1978.
34. J. A. Castle, "Design Criteria for High Efficiency Silicon Solar Cells with Concentration," 12th Photovoltaics Specialist Conference, Baton Rouge, LA, Nov. 1976.

35. E. L. Burgess and M. W. Edenburn, "One Kilowatt Photovoltaic Subsystem Using Fresnel Lens Concentrators," 12th Photovoltaic Specialists Conference, Baton Rouge, LA, Nov. 1976.
36. L. W. James et al., "Progress Report on a 1-KW Terrestrial Array of AL-GaAs/GaAs Concentrator Solar Cells," 12th Photovoltaic Specialist Conference, Baton Rouge, LA, Nov 1976.
37. Louis S. Napoli, RCA Labs, Personal communication.
38. A. Gorski, et al., "Novel Versions of the Compound Parabolic Concentrator for Photovoltaic Power Generator, 12th Photovoltaic Specialists Conference, Baton Rouge, LA, Nov. 1976.
39. N. S. Alvi, et al., "The Potential for Increasing the Efficiency of Photovoltaic Systems by Using Multiple Cell Concepts," 12th Photovoltaic Specialists Conference, Baton Rouge, LA, Nov. 1976.
40. J. J. Loferski, "Tandem Photovoltaic Solar Cells and Increased Solar Energy Conversion Efficiency," 12th Photovoltaic Specialists Conference, Baton Rouge, LA, Nov. 1976
41. G.W. Masden and C.E. Backus, "Increased Photovoltaic Conversion Efficiency Through Use of Spectrum Splitting and Multiple Cells," 13th Photovoltaic Specialist Conference, Washington, June 1978.
42. R.L. Moon, et al., "Performance of Individual Solar Cells With Different Bandgaps, Applicable to Multigap Solar Cells," 13th Photovoltaic Specialist Conference, Washington, June 1978.
43. A. Bennett and L. C. Olsen, "Analysis of Multiple-Cell Concentrator/Photovoltaic Systems," 13th Photovoltaic Specialist Conference, Washington, June 1978.
44. M.F. Lamorte and D. Abbott, "Studies of Two-Junction Monolithic Cascade Solar Cells," 13th Photovoltaic Specialist Conference, Washington, June 1978.
45. J. A. Cape, et al., "Spectrally Split Tandem Cell Converter Development," 13th Photovoltaic Specialist Conference, Washington, June 1978.
46. L.M. Fraas and R.C. Knechtli, "AlGaAs/GaAs/Ge Monolithic Dual Junction Solar Cell," 13th Photovoltaic Specialist Conference, Washington, June 1978.
47. A.G. Milnes, "Concepts for Rheotaxially-Grown Thin-Film Tandem III-V Solar Cells," 13th Photovoltaic Specialist Conference, Washington, June 1978.
48. M. Arienzo and J. J. Loferski, "Investigation of Potentially High Efficiency Photovoltaic Cells Consisting of Two Heterojunctions on a Common Wide Band Gap Semiconductor Base," 13th Photovoltaic Specialist Conference, Washington, DC. June 1978.
49. R.C. Williams and B.D. Wood, "Passive Cooling for Linearly Concentrated Solar Cell Arrays, 13th Photovoltaic Specialist Conference, Washington, June 1978

THIS PAGE INTENTIONALLY LEFT BLANK

APPENDIX A

CONCLUSIONS AND RECOMMENDATIONS SILICON TECHNOLOGY GROUP DOE PHOTOVOLTAIC CONCENTRATOR SYSTEMS WORKSHOP Scottsdale, Arizona May 24-26, 1977

Current Performance and Costs

There was general agreement that, at the present time, solar cells can be operated in the 50-300 sun range with conversion efficiencies of approximately 15% (cell conversion efficiency). At the present time cell sizes range from the relatively small RCA cells with dimensions of $.25 \text{ cm}^2$ (operating at 200 suns) to the Sandia cells (operating at 50 suns) which are approximately 2 in. in diameter.

The data in Table 1 were presented by Vic Dalal, University of Delaware. It summarizes some of the requirements and estimated costs of solar cell production in various concentration ranges. These cost figures were supported by various members of the group presently involved in the production of solar cells.

Major Problems and Identification of Unknowns

Major problem areas which were identified during the discussions are presented below.

There appears to be relatively little experience associated with optimal design of solar cells to operate at high intensities. Those cells which have been designed to operate at high intensities have performed quite well. However, there was general agreement among the participants that there are a number of effects which occur at high intensities which are either unimportant or non-existent in cells operating at low intensities. There is a need for basic studies on solar cell device physics dealing with lifetime at high intensities, and voltage saturation effects at high intensities. Further study of "heavy doping effects" which are important at low and high concentration ratios should be pursued.

Cell design, taking into account the device physics differences which occur when operating under high intensity conditions, will need to continue. There is general agreement that free carrier lifetime is an extremely crucial parameter, and, that if very high conversion efficiencies are to be expected from

concentrator solar cells, the lifetime will have to be significantly increased over present values in completed devices. This means that basic understanding of free carrier lifetime at high intensities must be developed. A study of processing techniques which will allow the fabrication of solar cells with very long lifetimes must be undertaken.

The area of antireflection coatings and encapsulation materials will need considerable work. There is relatively little information available on the properties of these materials under extreme intensity conditions and under the extreme thermal cycling which is expected to occur in solar cells operating under high intensity conditions. Also, corrosion data under these conditions are not available.

It does not appear that major technological breakthroughs are required to significantly improve the performance capabilities of silicon solar cells operating at high intensities. However, it does appear that considerable attention will need to be paid to processing techniques. In many cases, the use of very thin solar cells (100 microns or less) is being contemplated and handling techniques, particularly for very large wafers in this thickness range, are not readily available. Also, if thicker devices which utilize deep back diffusions to provide back surface fields are to be used, techniques for obtaining devices with a long lifetime under these processing conditions will need to be developed.

Recommendations and Projections

The recommendations for further technical development are as follows:

1. Continue cell development programs on BSF and IBC cells. Both of these cell designs appear to offer significant advantages over conventional solar cell design and the possibility of obtaining cell conversion efficiencies in excess of 20%.
2. Initiate work on transparent layer MIS cells for high concentration applications. This type of cell offers the possibility of low sheet resistance, reduced grid shadowing, and low temperature processing for the preservation of lifetime.
3. Initiate accelerated life test programs to determine failure modes and the possible need for encapsulation at high concentration ratios. In particular, the results of corrosion studies would be valuable in the selection of contact metals for high concentration solar cells.

4. Support work on encapsulation and anti-reflecting layer systems suitable for use on high concentration cells.

5. Support work on cell diagnostics. Little is known about the basic physical parameters of the cells under high illumination levels. Since these parameters determine the efficiency of the solar cell, which in turn strongly influences the electrical energy cost, it is important to mount an effort to study the cell parameters under high illumination levels. Such activities as studies of the effects of high lifetime starting materials, heavy doping effects, and techniques for the measurement of lifetime under high intensity conditions should be supported.

6. Support work on novel device fabrication technologies as a parallel effort to item 5. Undertake programs to study the influence of different device fabrication technologies such as ion implantation, diffusion and epitaxy on lifetime and emitter efficiencies. Suitable gettering techniques which enhance lifetime should also be studied.

Table 2 summarizes the projected performance of alternate cell design approaches.

Table 3 contains projections on performance and cost for silicon solar cells in the years 1980 and 1986. It should be emphasized that the projected cell efficiencies are for laboratory cells and the time scale is for laboratory devices. It is expected that production capabilities with these performance and cost figures in the quantities projected by ERDA will lag these times by approximately two years.

Table 1

Concentration	1-20	50	200
Wafer Diameter	4"	2"	4"
Base width (μm)	250	200	100
Breakage	Low	Low	Higher
Photolithography	No	Yes	Yes
Thick film	Yes	No	No
Contact diffusion	Np	No?	Yes
Dicing	Yes	No	Yes
# Steps	10	15	20
Polishing	No	?	Yes

(Assuming 15% cells, today's technology)

\$/k ²	6k	12K	15K-10K
\$/m ²	400	800-1K	1500

Table 2

PROJECTED RELATIVE PERFORMANCE OF ALTERNATE CELLS

Conventional	n
BSF	18-20%
IBC	20-22%
	20-22%

Table 3

PROJECTIONS

1980**	Concentration	Cell Size	\$/M ²	Comments
Cell Efficiency ^A				
18	300	.5-1 cm ²	2000	Good Si
17	50	5-15 cm ²	1000	Good Si
15	4	---	200	Low Cost Si
1986**				
Cell Efficiency*	Concentration	Cell Size	\$/M ²	Comments
20	300	.5-1 cm ²	1000	Good Si
20	50	5-10 cm ²	500	Good Si
15	4	---	24	Low Cost Si***

* Laboratory Cell Efficiency

** 2 Year Delay in Production

*** Success of the low cost sheet growth program is assumed

APPENDIX B

PROBLEM AREAS AND RECOMMENDATIONS OF THE GALLIUM ARSENIDE AND NOVEL APPROACH WORKING GROUPS DOE PHOTOVOLTAIC CONCENTRATOR SYSTEMS WORKSHOP Scottsdale, Arizona May 24-26, 1977

Problem Areas and Recommendations

Since almost all of the approaches of this Working Group are photovoltaic, many problem areas are general. Some problems which the Group felt should be addressed include: (1) materials and substrate quality, (2) encapsulation, (3) metallization and contact resistance, (4) lifetime testing under high illumination and (5) much improved costing estimates for large scale production of cell and optical systems.

It was also felt that there is a potential problem in obtaining concentration systems for low enough cost with concentrations above 500--particularly for thermophotovoltaics, which will require several thousand for the primary collector. An array cost allocation was estimated for two different approaches representing two different cost goals and time frames for attaining those cost goals. The nearer term goal (1986) of \$500 per peak kW was matched to the conventional GaAs concentrator cell program and a 1990 goal of \$250 per peak kW was geared to the multi-color higher efficiency schemes. The price allocations are presented in Table I.

An additional problem comes to mind when working with pricing or system costing--that of using the correct means of computing system efficiencies. Clearly costs per peak watt are much less satisfactory for concentrator systems where the energy collected per day may vary considerably between different optical systems and their means of tracking, or even between different days for the same system because of varying atmospheric conditions.

Since the desired cell area is of the order of one cm^2 , the high concentration factor implies very small ($\sim 1 \text{ ft}^2$) uneconomical mirrored concentrator systems, as there is some question as to the feasibility of obtaining a concentration of 1000 with fresnel lenses. Thus, matrix arrays of cells are needed, perhaps with non-circular geometry, with schemes to eliminate the busbar contacts from the illumination area. The use of secondary low concentrators, such as compound parabolic concentrators, may be useful for this purpose.

The multi-junction cells require considerable development with regards to material compatibility and the required ohmic heterojunctions, whereas the spectrum splitting scheme requires less cell development, but the development of very selective bandpass filters which can operate for long periods at high concentration.

The thermophotovoltaic device appears very sound as to its modeling, but will require major improvements in maintaining high carrier lifetimes, low absorption of IR at the backsurface, and reflectivity and stability of the radiator material.

Table I. Array Cost Allocations
Array Price Goals

Cost Element	<u>\$500/KW (1986)</u> (GaAs Solar Cell)		<u>\$250/KW (1990)</u> (Multi-Color)	
	X = 500, CELL = 25%		X = 1000, CELL = 35%	
	\$/m ²	\$/KW _p	\$/m ²	\$/KW _p
Solar Cell and Assembly	20 (10,000)	100 (50,000)	20 (20,000)	71 (71,000)
Conc. Optics	30	150	20	71
Array Structure and Tracking	35	175	20	71
Assembly and Test	15	75	10	37
	<u>\$100.00</u>	<u>\$500.00</u>	<u>\$70.00</u>	<u>\$250.00</u>

() = UNCONCENTRATED COST

INTERNATIONAL DEVELOPMENTS IN CONCENTRATORS

By

J. D. Walton, Jr.
Solar Energy and Materials Technology Division
Engineering Experiment Station
Georgia Institute of Technology
Atlanta, Georgia 30332

I. INTRODUCTION

This paper discusses the international development of concentrating collectors primarily as related to the applications for which they are being developed. Although the paper emphasizes recent and on-going activities, it is important to remember that there is more of a history of solar concentrating technology in Europe and particularly in France than in the United States. This, at least in part, is due to the fact that high temperature solar concentrators were being developed in support of the scientific revolution which was so active in Europe in the 18th and 19th centuries at a time when the United States was more occupied with the problems of developing a nation. Also, it should be noted that the basic devices used in these early experiments were rather sophisticated and that variations of these concentrators form the basis for a number of the systems being developed today. For that reason a brief review of significant past accomplishments is presented here.

Two of the more famous concentrating devices developed in France during the 18th and 19th centuries were those of Lavoisier and Mouchot. Figure 1 shows the apparatus used by Lavoisier during the 1770's 1. The large concentrating lense was 52 inches in diameter and was made of two convex sheets of glass clamped together with the space between them filled with white wine. With this furnace Lavoisier was able to melt platinum and to identify the composition of diamond. Such devices (burning glasses) became very popular in Europe and the United States during the 18th century. Benjamin Franklin carried out many high temperature experiments using a similar, but smaller device and Priestly, an admirer of Franklin, used a

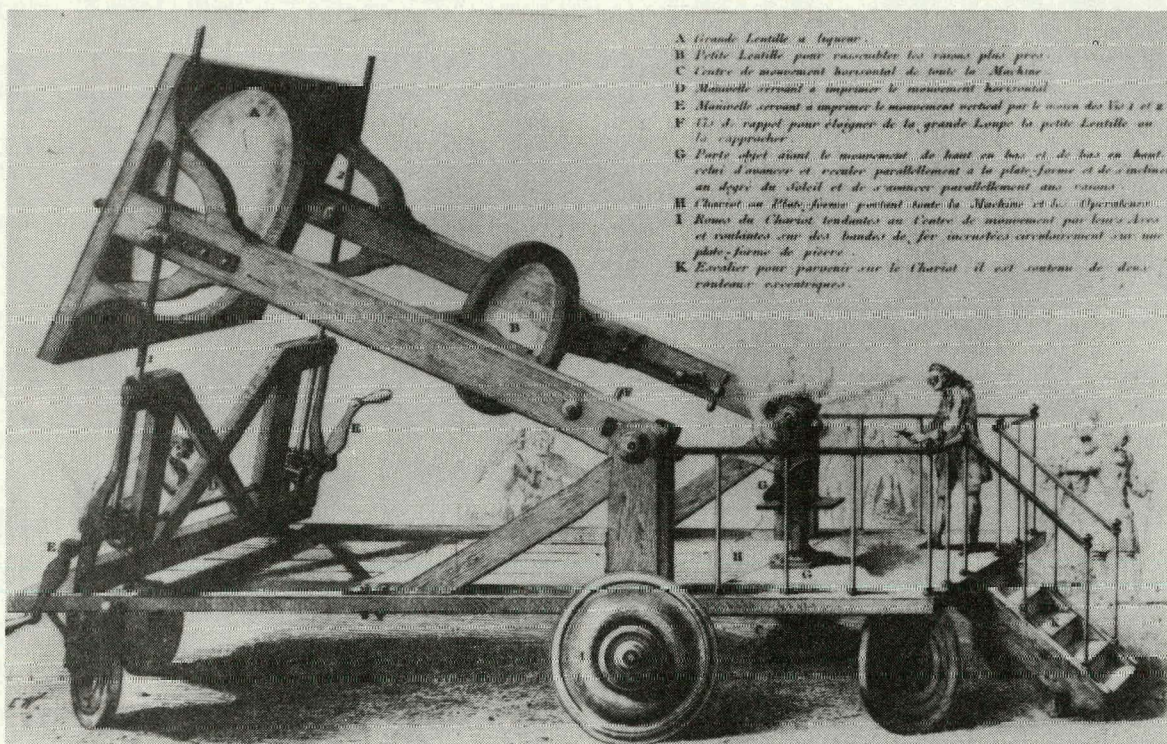

Figure 1. Apparatus Used by Lavoisier for High Temperature Chemical Experiments.

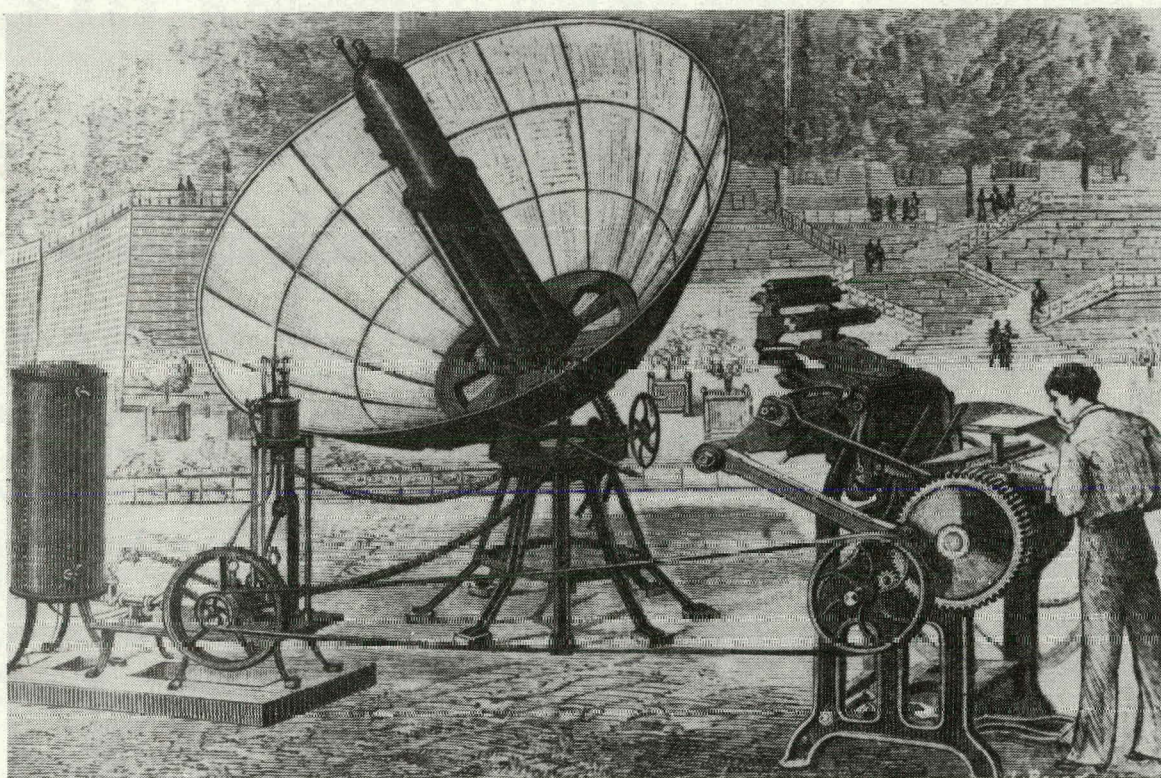

Figure 2. Solar Boiler of Mouchot Used to Power a Printing Press in the Tuileries Gardens in 1861.

burning glass in his experiment which led to the discovery of oxygen in 1774. Although lenses have the ability to provide very high concentration ratios, large glass lenses are difficult to fabricate and thus are very expensive. Probably the most recent relatively large scale furnace using multiple glass lenses was the one built by Professor Pol Duwez at Cal Tech during the 1950's. In India there is at least one current effort to develop a large concentrating lense using two convex sheets of acrylic plastic filled with water 2/. Unfortunately, because of the weight of the liquid and the strength of large sheets of glass or plastic such lenses probably will be limited to sizes not much larger than the one used by Lavoisier. However, this concept might be used to develop very large and optically good lenses for applications in space where gravity does not present the problem it does on earth.

A forerunner of some of today's solar thermal conversion systems, the concentrating collected used by Mouchot in 1861 to power a steam driven printing press is shown in Figure 2 3/. A contemporary of Mouchot, John Ericsson pioneered the development of solar concentrators for mechanical power applications in the United States 4/. However, in addition to mechanical power, Mouchot successfully demonstrated the usefulness of concentrating collectors for such processes as the distillation of sulfuric acid, the preparation of benzoic acid and the purification of linseed oil 3/.

Although most current applications for concentrating collectors in the United States are related to commercial or industrial thermal processes, it is likely that in the future increasing attention will be given to chemical processes, high temperature materials processing and to the development of synthetic fuels. It is for that reason that space is given here to the historial development of concentrating collectors; and that is why the next section describes the large scale solar collector systems built and operated during the past 25 years in France, Algeria, Italy and Japan, since they were developed for such applications. For that reason they provide a rich resource of practical experience which can assist U. S. programs in the areas of high temperature technology, as well as component development, system demonstration and experimentation.

II. BACKGROUND

This section: (1) describes and characterizes the five large solar furnaces (over 10 kWt) built outside of the United States since 1950, (2) reviews the major solar thermal conversion systems which were built and demonstrated during the past 15 years with emphasis on the activities of the past two years, and (3) describes the use of the CNRS 1000 kWt solar furnace to evaluate the Martin Marietta cavity type receiver for steam generation and the CNRS oil cooled receiver used to produce electric power through a steam turbine.

A. Solar Furnaces

The five solar furnaces described in this section are of two basic types: (1) direct solar concentration using a paraboloid concentrator, and (2) redirection of solar radiation from one or more heliostats to a paraboloid or spherical concentrator. These furnaces were developed primarily for high temperature research and development. They are described in chronological order and the characteristics, type of construction, significant features and available performance data considered to be of importance to U. S. programs are summarized.

1. Montlouis Solar Furnace

The first large solar furnace was developed by the Centre National de la Recherche Scientifique (CNRS), France under the direction of Professor F. Trombe and was constructed at Montlouis in the French Pyrenees 5/. This furnace, shown in Figure 3, was completed in 1952 and became the prototype for other large high temperature solar furnaces. This design utilizes a single large heliostat 13 meters wide and 10.5 meters tall that contains 540 flat second surface silvered mirrors each 50 x 50 cm. The concentrating collector is made up of 3500 second surface silvered glass mirrors 16 x 16 centimeters arranged on a parabolic framework 11 meters wide and 9 meters high with a focal length of 6 meters. Each of the 3500 fat mirror elements in the concentrator was mechanically contoured and aligned to focus the radiation received from the heliostat onto the focal point of the parabola.

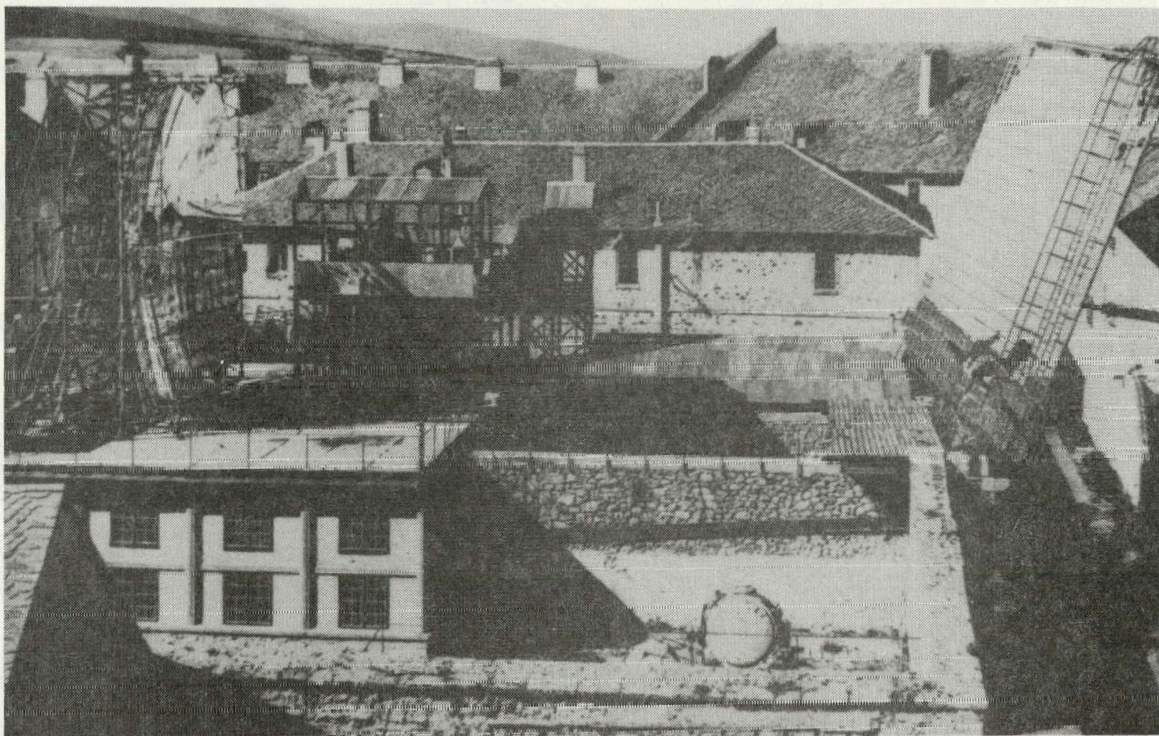

Figure 3. First Large Scale Solar Furnace Built by CNRS at Montlouis France.

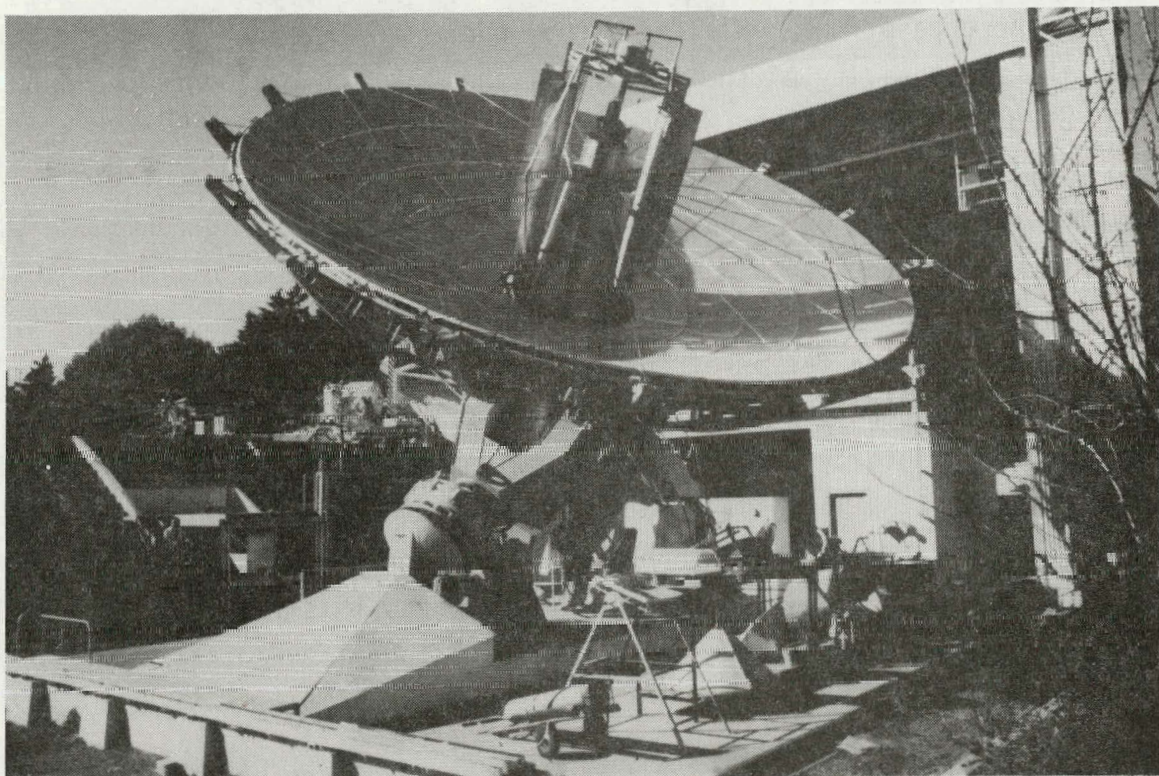

Figure 4. Paraboloid Dish Solar Furnace at Bouzareah Near Algiers.

This furnace develops about 45 kW of thermal power and provides a maximum temperature in excess of 3000°C with a peak heat flux of 1200 w/cm^2 . The successful use of this facility led to the use of its design as the prototype for the next three large, single heliostat solar furnaces built during the next 20 years.

2. Bouzareah

At the same time that the Solar Energy Laboratory was being established at Montlouis, the Organisme National de la Recherche Scientifique (ONRS) was developing a reflecting paraboloid dish solar furnace at Bouzareah, Algeria 6/. This furnace does not use a heliostat since it follows the sun directly. Electropolished aluminum was used as the reflecting surface. In order to protect the aluminum surface from excessive corrosion tracks are located on each side of the concentrator so that a building mounted on wheels can move on this track to cover the concentrator when not in use. Figure 4 is a photograph of this furnace which began operation in 1954. The diameter of the paraboloid dish is 8.14 meters and the focal length is 3.14 meters. The surface area of the collector is 50 square meters. During the past 15 years the reflectivity of the electropolished surface has decreased from 0.83 to about 0.7. Efforts presently are underway to repolish this surface. Also during these 15 years, the focal area has changed from a circle 6 centimeters in diameter to an elliptical shape about 20 x 10 centimeters. Currently it produces about 12 kW of thermal power. It is estimated that the original power provided by this facility was of the order of 25 kWt. With a concentration factor of about 17,000 this furnace provides a maximum temperature of about 3500°C . The system utilizes a massive support structure for rigidity and has a gross weight of 40 tons. It currently is being used for high intensity photochemical research and in heat exchanger experiments related to the French CNRS Solar Thermal Power program. The electropolished uncoated reflective surface makes this facility particularly useful for research requiring concentrated ultraviolet radiation.

3. Sendai

The Tohoku University operates a 35 kWt solar furnace at Sendai,

Japan 7/. Although it is constructed on the same general principal as the CNRS Solar Furnace at Montlouis, there are significant differences in construction. These are: (1) the mirrors on both the heliostat and the paraboloid concentrator are front surface aluminized glass, and (2) the heliostat is composed of seven rows of flat mirrors in a stair step arrangement. Since aluminized first surface mirrors are used, this facility is particularly well suited for high power, high concentration photo chemical experiments. However, in order to overcome the relatively poor corrosion and scratch resistance of the aluminized mirror surface it was necessary to provide some sort of surface protection. This was accomplished by developing a vinyl coating. Using a ratio of solute to solvent of 1:3 and dipping the mirrors in this solution a coating of several microns was obtained with a surface of sufficient smoothness to meet the desired reflectivity of 1 milliradian. The coated mirror provided essentially the same reflectivity as the uncoated freshly aluminized surface and has proven durable and protective, and when washed with water and gauze no loss in reflectivity has been observed over a period of about two years. The paraboloid concentrator is located inside of a protective shelter and the heliostat is provided with a cover to protect the mirrors when not in use. Figure 5 is a photograph of the paraboloid concentrator, and Figure 6 is a photograph of the heliostat of the Sendai Solar Furnace. The concentrator contains 181 mirrors 80 x 75 centimeters and the heliostat seven rows of 34 mirrors (238) each 200 x 91 centimeters. The proper paraboloid contour was ground into the surface of each of the concentrating mirrors. This furnace has been used extensively in the measurement of the high temperature properties of materials, for high temperature x-ray diffraction studies, and currently is being used in the study of high temperature dissociation of water to produce hydrogen.

4. Odeillo-CNRS 1000 kW Solar Furnace

The world's largest solar furnace, the CNRS 1000 kW Solar Furnace 8/ was constructed at Odeillo about 10 kilometers west of Montlouis, France. Probably the best known of the large solar furnaces, it was built on the same principal as its predecessor at Montlouis and its success is undoubtedly related to the experience gained at Montlouis. The most notable differences

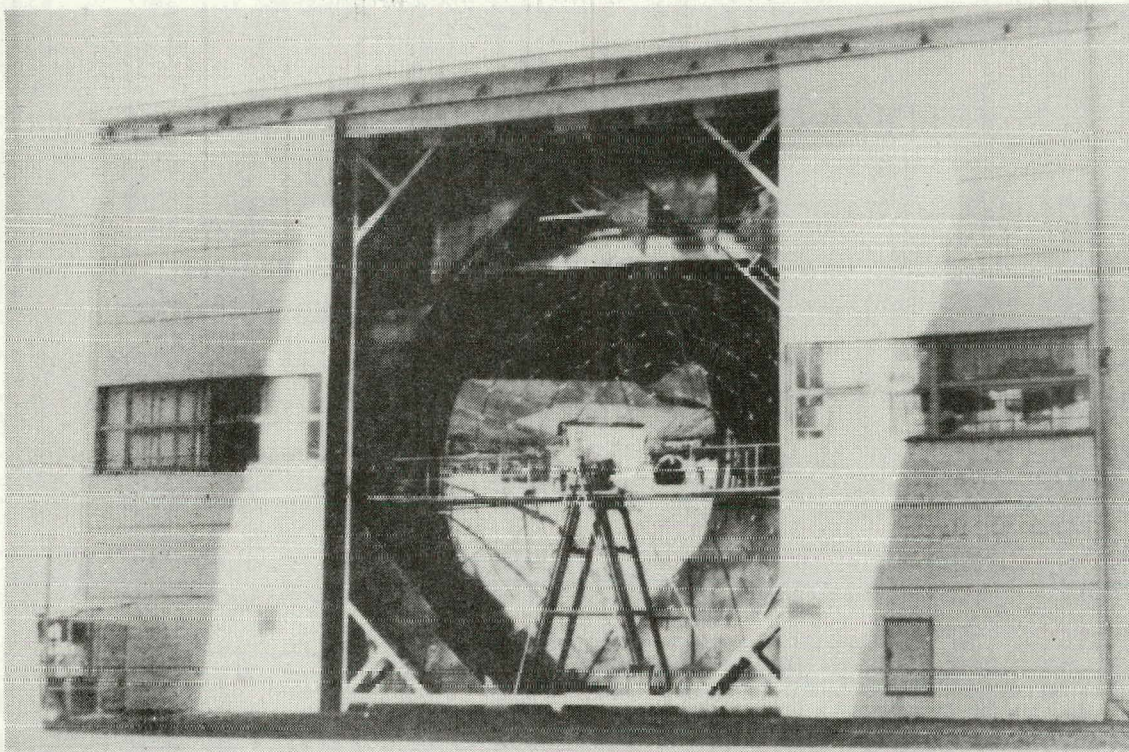

Figure 5. Paraboloid Concentrator of Tohoku University Solar Furnace at Sendai, Japan.

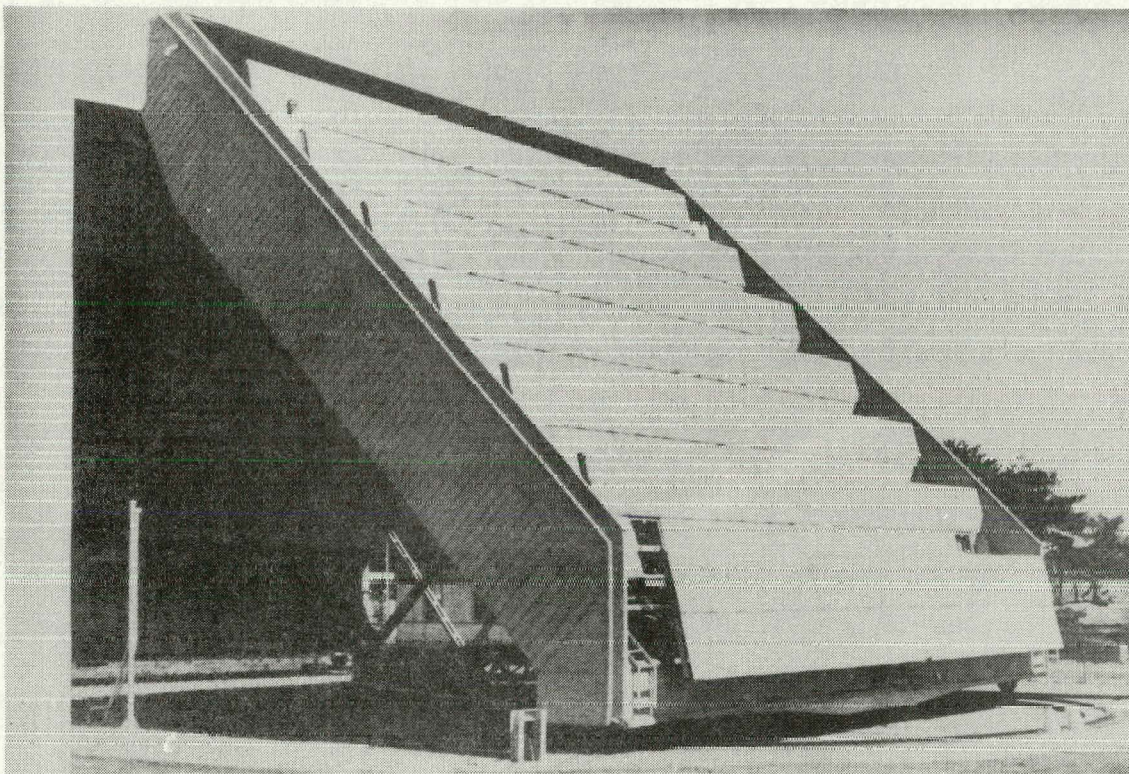

Figure 6. Heliostat of Tohoku University Solar Furnace at Sendai, Japan.

between the CNRS 1000 kW Solar Furnace and the Montlouis furnace are: (1) its size, and (2) the number of heliostats. The Odeillo facility was the first solar furnace to use multiple heliostats and provided a prototype situation for present day central receiver solar power concepts. Also, it is interesting to note that the size of the heliostat at Odeillo, much smaller than the single heliostat at Montlouis, is essentially the same size as those currently being designed for central receiver solar power systems, about 40 square meters. The CNRS 1000 kW Solar Furnace was constructed over almost a ten year period, beginning operation in 1970. It was designed primarily for the study of high temperature processing of refractory material and for high temperature chemistry. Figure 7 shows schematically the principal of operation of this facility. Figure 8 is a photograph of the parabolic concentrator which is incorporated into the north side of the laboratory and office building of the CNRS Solar Energy Laboratory.

The 63 heliostats are each 7.5 meters wide by 6 meters high and contain 180 flat mirrors, each 50 x 50 centimeters. Each heliostat is designed to illuminate a specific arc of the parabola (along a line parallel to the axis of the parabola) and is provided with a dual mode, optical control system which maintains the proper orientation of the heliostat through a hydraulic drive system. This dual system permits each heliostat to be operated in either a "search" or "track" mode. In both cases the optical guidance system is an optical tube with four photodiodes that control the heliostat motion in east-west, up-down directions, through a closed loop system. When operating in the "search" mode a short (10 centimeters) tube with a 40 degree acceptance angle is used to activate the "fast" hydraulic system in an on-off mode to quickly bring the heliostat within the operating range of the "track" system. In the "track" mode a 100 centimeter tube is used to control a slower acting hydraulic system which operates in a proportional control mode. The size of the image of the sun at the base of the 100 centimeter tube is 1.25 centimeters and the accuracy of control is one minute of arc.

The concentrating parabola has a focal length of 18 meters, is 40 meters high and 54 meters wide. It consists of 9500 initially flat glass second surface silvered mirrors 45 x 45 centimeters. Each mirror was mechanically

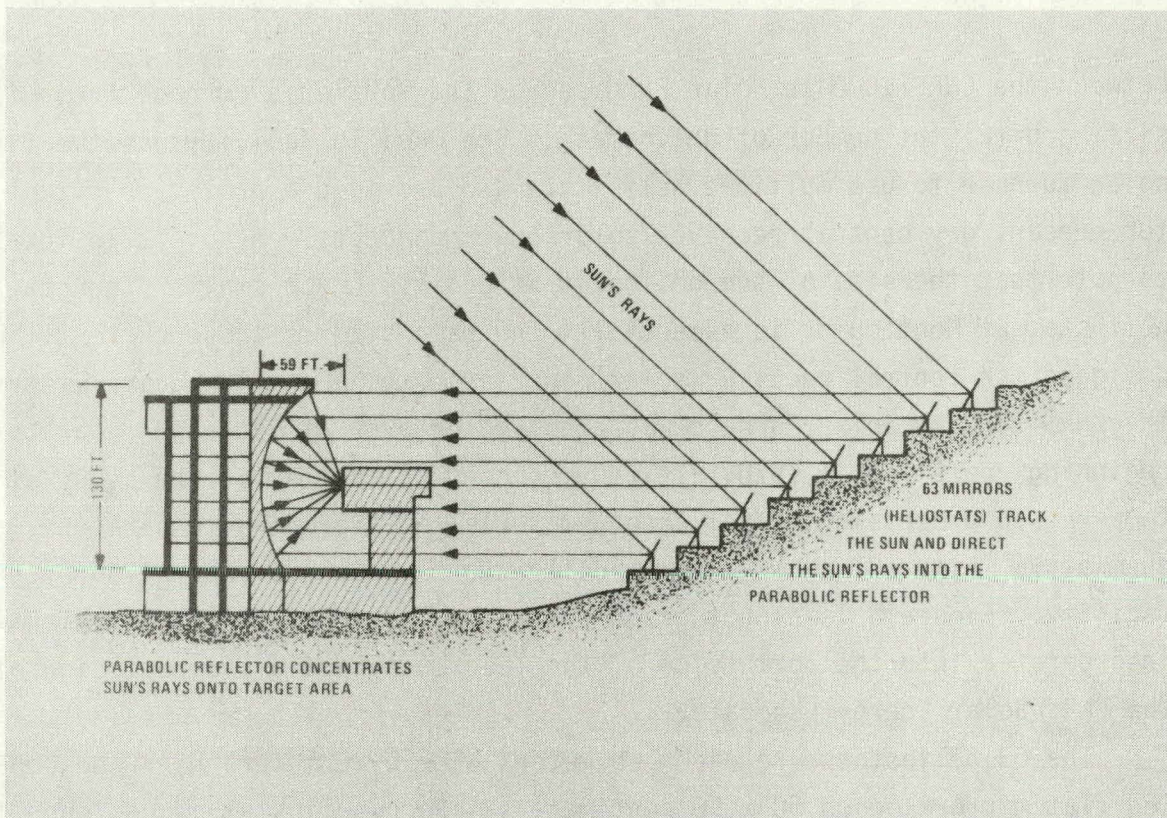

Figure 7. Schematic Showing Operation of CNRS 1000 kW Solar Furnace at Odeillo, France.

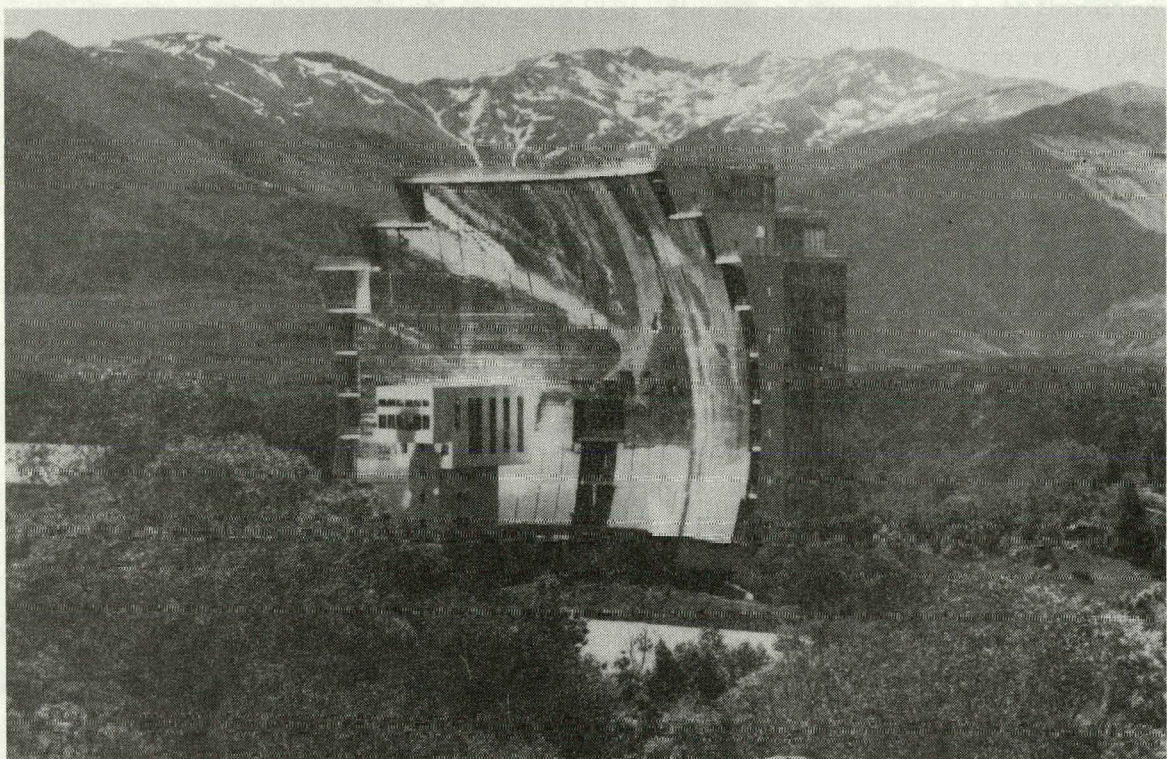

Figure 8. Paraboloid Concentrator of CNRS 1000 kW Solar Furnace at Odeillo, France.

curved and adjusted to provide a solar image of minimum diameter at the focal point. Two years were required to accomplish the two precise adjustments on each of the 9500 mirrors which was accomplished on 1 October 1970. The precision with which the CNRS 1000 kW Solar Furnace is constructed, together with its size, provide it with the highest heat flux and temperature of any large scale solar furnace in the world. Although only one-fifth the power of the DOE 5 MWt Solar Thermal Test Facility at Albuquerque, the maximum heat flux is almost an order of magnitude higher and it can provide a peak temperature about 1500°C higher. Heat flux data in watts per square centimeter obtainable in the focal zone of the CNRS 1000 kW Solar Furnace is presented graphically in Figure 9. Curve 0 is for a vertical plane through the focal point, curve d/2 is for a plane one-half the diameter of the solar image (8.5 centimeter) behind the focal plane and curve d is for a plane removed one diameter of the solar image (17 centimeters) behind the focal plane. Figure 10 is an energy contour map showing the heat flux distribution in watts per square centimeter on a plane inclined at 25 degrees (away from the parabola) from the vertical with its center at the focal point of the parabola. The maximum temperature obtained with this furnace is about 3600°C .

5. Odeillo, French Army

In 1972, the French Army began operating a 45 kWt solar furnace at Odeillo, only a few hundred yards from the CNRS 1000 kW Solar Furnace. Built on the same principal as the Montlouis furnace it was designed primarily for the study of nuclear thermal effects 9/. Figure 11 is an overall view of this facility. The heliostat is shown on the left and the concentrator is in the building on the right. Significant features of this facility are: (1) The concentrator is a spherical configuration using first surface aluminized mirrors, and (2) the heliostat is the largest, single plane heliostat ever used (13.2 x 17.5 meters). This heliostat is shown in Figure 12.

Table 1 lists the principal characteristics of the five large scale solar furnaces, described in this section. Although developed over a 25 year period, all five of these furnaces are still in active use and each is contributing to the advancement of solar energy technology.

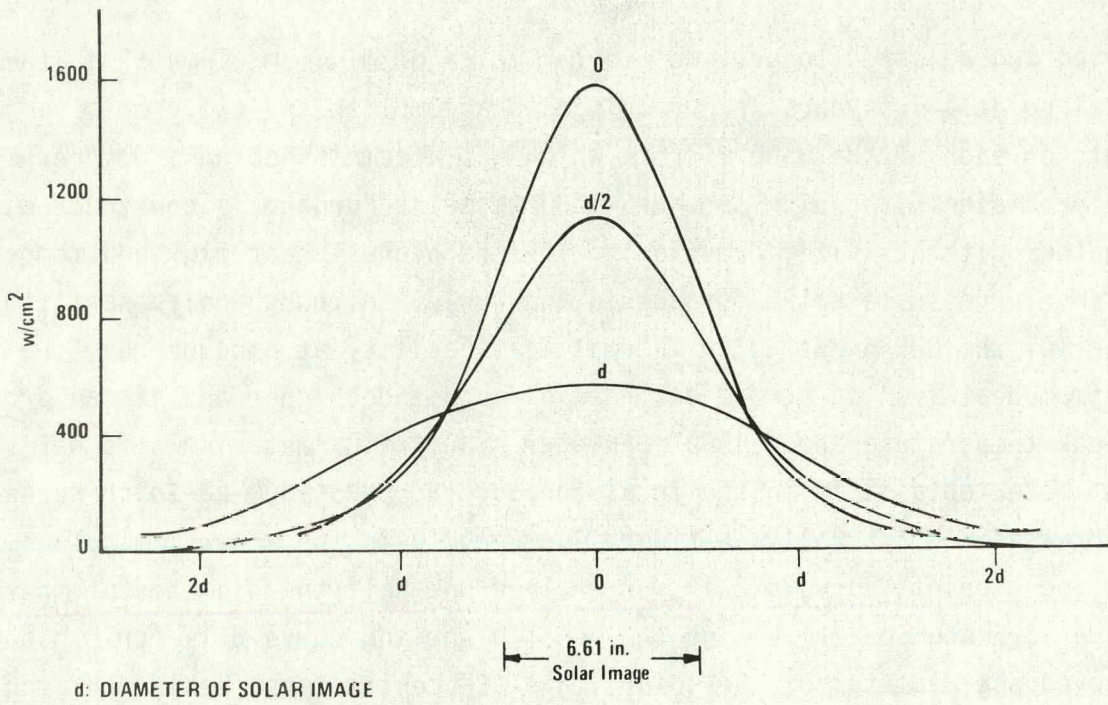

Figure 9. Heat Flux in Focal Zone of the CNRS 1000 kW Solar Furnace.

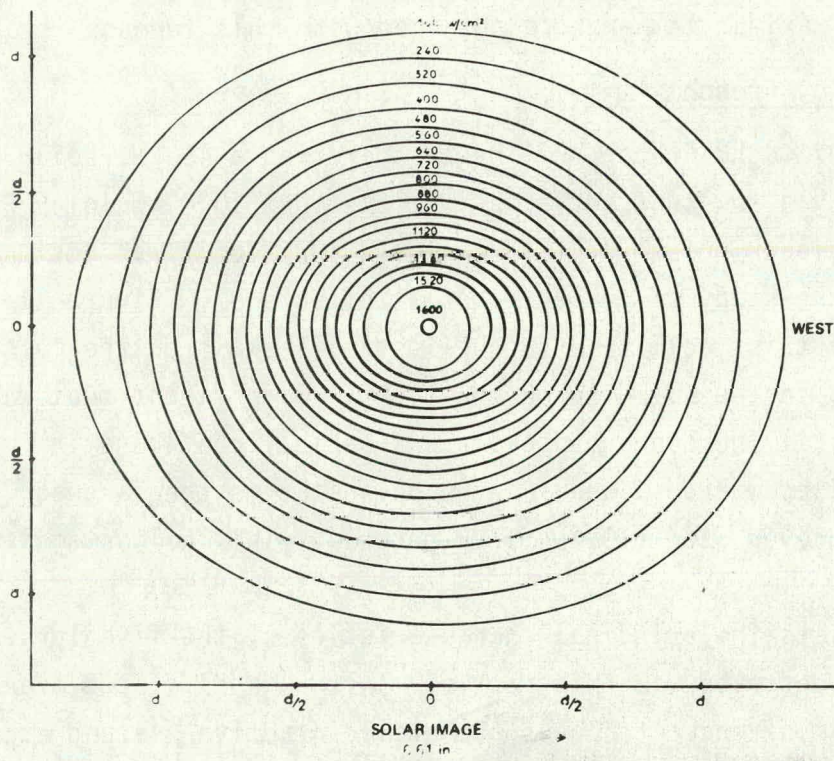

Figure 10. Heat Flux Contour Map of the CNRS 1000 kW Solar Furnace.

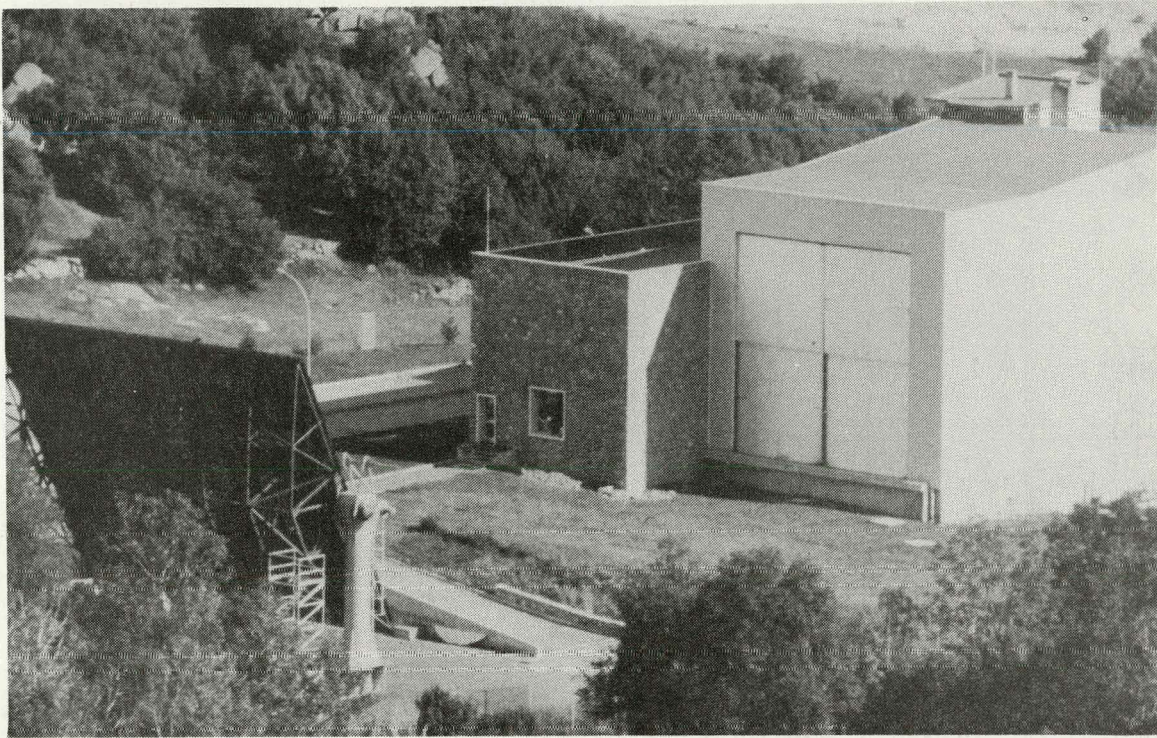

Figure 11. French Army Solar Furnace at Odeillo, France.

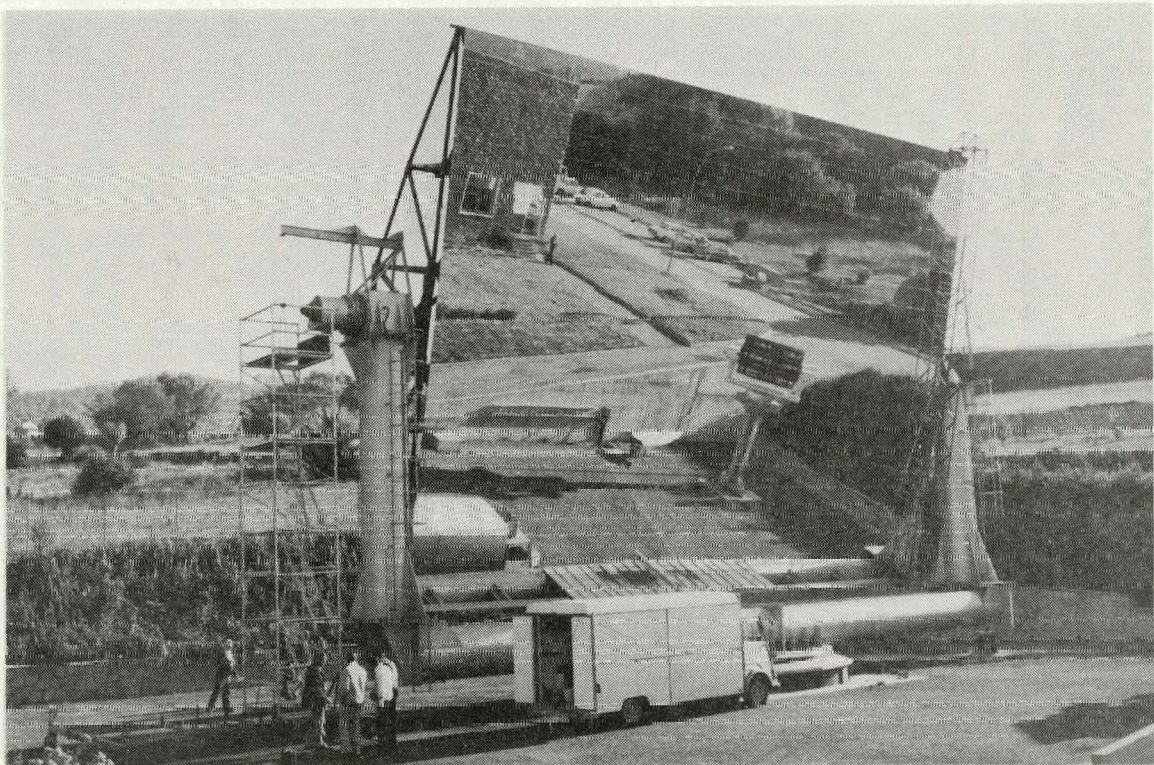

Figure 12. Heliostat of French Army Solar Furnace at Odeillo, France.

TABLE 1

CHARACTERISTICS OF LARGE SOLAR FURNACES

	CNRS Montlouis France	ONRS Bouzareah Algiers, Algeria	Tohoku University Sendai Japan	CNRS Odeillo, France	French Army Odeillo, France
<u>Date First Operated</u>	1952	1954	1962	1970	1972
<u>HELIOSTAT</u>					
Number of Heliostats	1	---	1	63	1
Heliostat Size (meters)	10.5 x 13	---	14 x 15.5	6 x 7.5	13.2 x 17.5
Type of Mirror	2nd Ag	---	1st Al	2nd Ag	2nd Ag
Number of Mirror Elements in Each Heliostat	540	---	238	180	638
Mirror Element Size (centimeters)	50 x 50	---	90 x 100	50 x 50	50 x 50
Mirror Area in Each Heliostat (square meters)	135	---	214	45	159.5
Total Number of Heliostat Mirror Elements	540	---	238	11,340	638
Total Heliostat Mirror Area (square meters)	135	---	214	2,835	159.5
<u>CONCENTRATOR</u>					
Configuration	Paraboloid	Paraboloid Dish	Paraboloid	Paraboloid	Spherical
Size (meters)	9 x 11	8.14 (Diam)	10 (Diam)	40 x 54	10 x 10
Type of Mirror	2nd Ag	Electropolished Aluminum	1st Al	2nd Ag	1st Al

(Continued)

TABLE 1 (Continued)

CHARACTERISTICS OF LARGE SOLAR FURNACES

	CNRS Montlouis France	ONRS Bouzareah Algiers, Algeria	Tohoku University Sendai Japan	CNRS Odeillo, France	French Army Odeillo, France
<u>CONCENTRATOR (Continued)</u>					
Number of Mirror Elements	3500	---	181	9,500	384
Mirror Element Size (centimeters)	16 x 16	---	80 x 75	45 x 45	50 x 50
Total Mirror Area (square meters)	89.6	50	109	1,923	96
<u>THERMAL PERFORMANCE*</u>					
Total Thermal Power (kW)	45 (est)	25 (est)	35 (est)	1,000	42.5
Maximum Thermal Efficiency (%)	55 (est)	---	50 (est)	58	48
Maximum Heat Flux (w/cm ²)	1,200	---	---	1,600	580
* Based on Insolation = 900-950 w/m ² .					

B. Solar Thermal Conversion Systems

This section briefly reviews the development of relatively large scale experimental solar systems built during the past 10 years for the purpose of demonstrating or studying various techniques for concentrating solar energy for thermal power applications.

1. Italy

The first large scale (100 kWt) demonstration of the production of high temperature, high pressure steam using concentrated solar energy was that of Professor Giovanni Francia, University of Genoa, Italy. This was accomplished with a central receiver "power tower" type solar thermal system built at St. Ilario, Italy, in 1967. A more advanced facility was constructed at the same site in 1972. This facility, shown in Figure 13, used 271 flat mirrors, each one meter in diameter, arrayed in a hexagonal pattern to direct the sun's rays onto a cavity type steam boiler-superheater suspended 9 meters above the center of the mirror field. With a direct insolation of 900 watts per square meter, this facility produced 150 Kg of steam per hour at 150 atmospheres and 500⁰ C giving an overall efficiency of 70 percent.

A unique feature of Professor Francia's facility was his design of the mechanical system used for supporting the mirrors and tracking the sun. The individual mirror support-tracking system is referred to as a "kinematic motion" (KM) device. All of the KM devices are mechanically linked together to a common drive shaft so that they move together to follow the sun by means of a single clockwork drive mechanism.

Because of the excellent performance of this facility, the simplicity of the tracking device and the suitability of the overall design for providing an intermediate size test facility for evaluating advanced central receivers, components and materials, Georgia Tech proposed to ERDA that a somewhat larger version of this facility be constructed at Georgia Tech for use as an ERDA research and test facility. This proposal was approved and a 400 kWt test facility of Professor Francia's design was funded by the Department of Energy. It was engineered by Ansaldo, Spa, Genoa, Italy, installed by Georgia Tech and is being operated by Georgia Tech for the Department of Energy as an

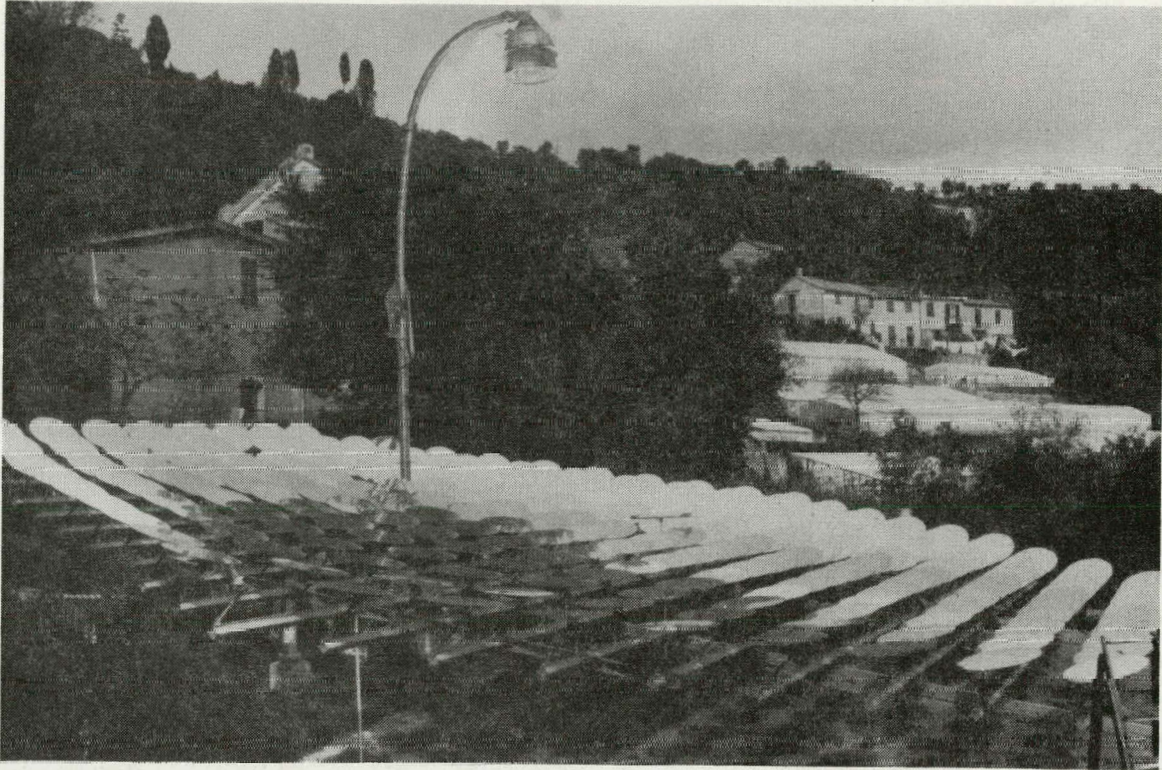

Figure 13. Solar Steam Generating Plant at St. Ilario, Italy.

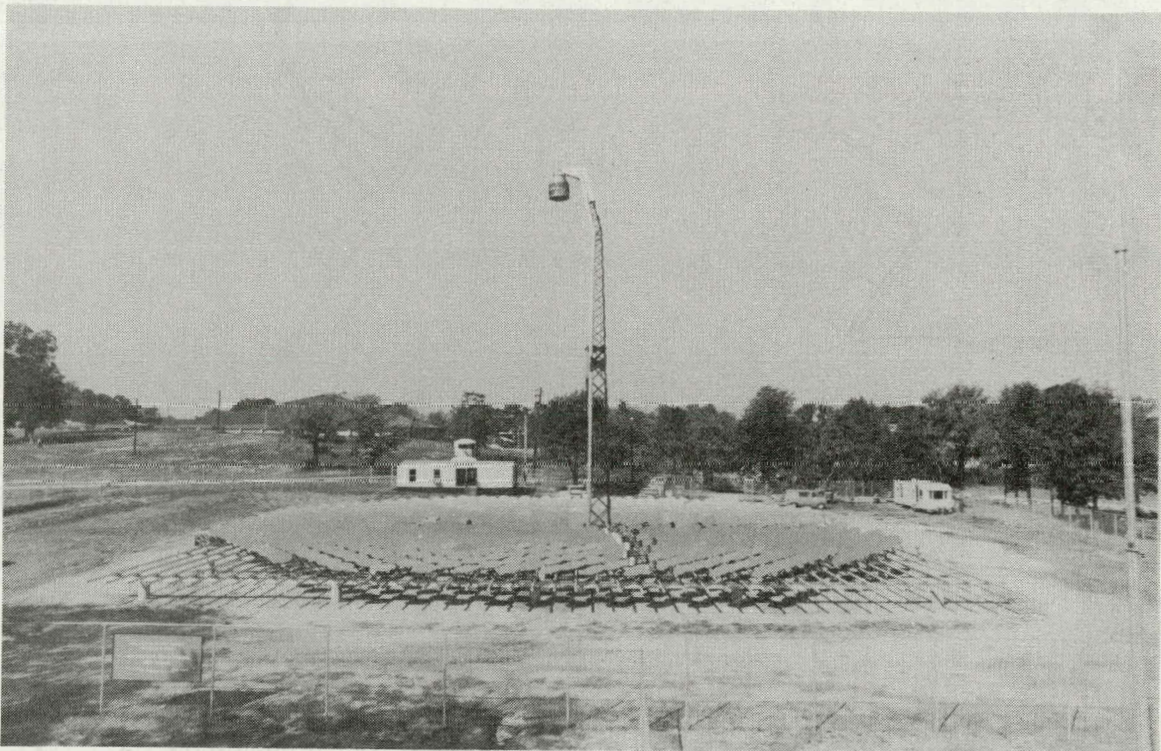

Figure 14. DOE Advanced Components Test Facility at Georgia Tech Designed by Professor Francia, Genoa, Italy.

Advanced Components Test Facility. Figure 14 is a photograph of this facility on the Georgia Tech campus 11/.

Since the kinematic motion device is one of the most significant features of these facilities and since its basic design is used in the Japanese central receiver system (discussed in the next section), it is described here. Figure 15(a) shows the principle of operation of the KM device. Point A is used as a reference point. Line AB is the extension of a line drawn from the sun through point A. Line CA is the extension of a line drawn from the receiver through point A. Lines CA and AB are of equal length and form the equal sides of the equilateral triangle ACB. A mirror is placed at point M perpendicular to line MCB. Since line MCB is parallel to the bisector of angle SAR, the mirror surface will reflect the light from

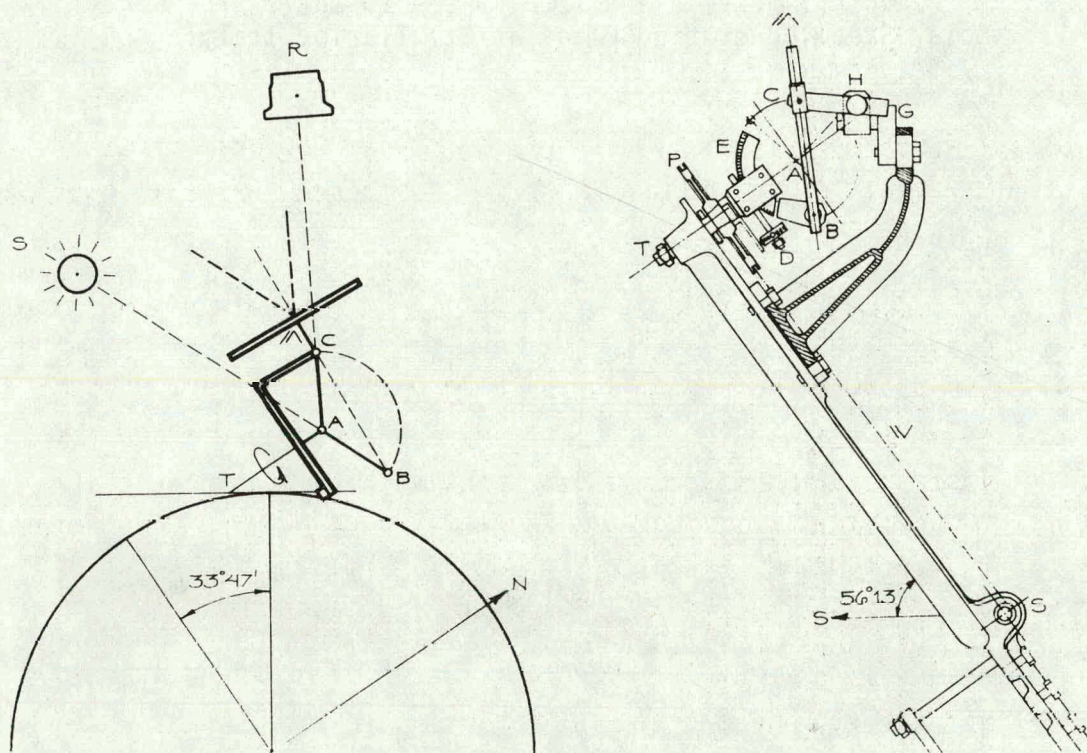

Figure 15. (a) Schematic Showing Operation of Kinematic Motion Device, (b) Drawing of Kinematic Motion Device for DOE Advanced Components Test Facility at Georgia Tech, Designed by Professor Francia.

the sun (point S) onto the receiver (point R). Point B rotates about axis TA, (parallel to the earth's axis) at $15^{\circ}/\text{hr}$ and MCB rotates around point C. This figure is oriented so that axis TA is parallel to the earth's axis when located at the latitude of Atlanta ($33^{\circ} - 47'$). Figure 14(b) is a drawing of the kinematic motion and support arm for the Georgia Tech test facility. The axis of rotation is shown by line AT which is located parallel to the earth's axis. Rotation is provided by a cable W around the pulley at P and driven through the shaft S. Alignment with the sun (line AB) is provided by a worm gear at D acting on the circumferential gear arm E. Declination adjustments also are provided through D. Alignment of the receiver (line AC) is provided through point H attached to a movable collar on the fixed rod G.

The major components of the facility include an octagonally shaped mirror field which contains 550 mirrors 111 cm in diameter. The field of mirrors focus sunlight into a focal zone 21.4 meters over the center of the field. The mirrors may be individually adjusted to tailor the heat flux distribution and intensity to particular experimental needs. The maximum radiation flux density is approximately 214 w/cm^2 in the central focal zone, and the total power into the focal zone is 400 kWt. The original test stand was an articulated truss located in the center of the field that was capable of supporting a 700 kg (1540 lb) test device. Early in 1978, this stand was replaced with a rigid tower capable of supporting a 9100 kg (20,000 lb) test device.

During the process of completing the assembly and checkout of the facility, a program was undertaken to determine the various errors associated with the heliostat system and from these data determine the potential performance of the facility. The results of this program are summarized in Table 2. From these data an estimate was made of the radiant heat flux and power distribution at the focal plane. These estimates are based on a mirror reflectivity of 0.9, blocking and shadowing factor of 0.98 and a cosine factor of 0.95. They are summarized in Table 3.

During its initial operation, the heliostat field performance was outside the limits previously described. The most important source of error have been identified as: (1) alignment technique, (2) alignment tooling inaccuracies,

TABLE 2
 ERRORS ASSOCIATED WITH THE HELIOSTAT FIELD

<u>Error Source</u>	<u>Error</u> (milliradians)
Aiming	3
Tracking	3.9
Total Tracking	4.9
Mirror Image	4.7
Total Mirror Field	6.6

TABLE 3
 ESTIMATED HEAT FLUX AND POWER DISTRIBUTION AT THE
 FOCAL PLANE OF THE GT/STTF

<u>Diameter of Circle at Focal Plane</u> (cm)	<u>Intensity At Perimeter of Circle</u> (w/cm ²)	<u>Total Power in Circle</u> (kW)	<u>Power In Circle</u> (%)
0	214	0	0
12.7	200	26	6
25.4	163	95	24
38.1	115	183	46
50.8	71	265	66
63.5	39	326	82
76.2	18	264	91
88.9	7	384	97
101.6	2.5	393	99
114.3	0.8	396	99
127.0	0.25	398	100

and (3) mirror frame design. Steps are being taken to remove all three error sources. As a result of the learning period during the installation of the facility, the alignment technique has been revised and is being applied to the readjustment of the KM devices. The alignment tooling required in this task has been recalibrated to further reduce systematic errors. Finally, sturdier mirror frames are being designed and built. With these actions, the heliostat field is expected to operate according to its design specifications.

The Georgia Tech facility is being operated initially as a solar steam generating system. The principal component of this system is the central receiver (solar boiler and superheater). This receiver represents another area in which Professor Francia has made a significant contribution to concentrating collector technology. Figure 16 is a cutaway drawing of the receiver designed for the Georgia Tech facility which consists of a preheater section, two boiling sections and a superheater. The inside surface of the preheater section is chromium plated. This provides essentially a secondary concentrator which redirects incoming radiation into the cavity. Because of the open spacing of the two bundles of boiling tubes (all with specular surfaces) the incoming radiation is scattered throughout the receiver minimizing hot spots and increasing the uniformity of heating of all sides of all boiling tubes. The superheater consists of a clover leaf-serpentine coil of tubes buried inside the dome top of the receiver. The inside space between the boiling tubes and the tubes and preheater section is filled with hanging borosilicate glass tubes. The end of the tube facing the incoming radiation is open. These tubes are used to create what Professor Francia describes as a "honeycomb anti-radiating structure." Because of the high capture efficiency of this system a relatively large aperture "cavity" receiver can be designed. This is particularly important for the mechanically driven mirror system which provides less accurate mirror aiming than with electronically driven heliostats. In this case the diameter of the open end of the receiver is approximately $1\frac{1}{2}$ meters, almost equal to the height of the receiver. Figure 17 is a photograph of the Georgia Tech receiver in operation. In a similarly designed, but smaller

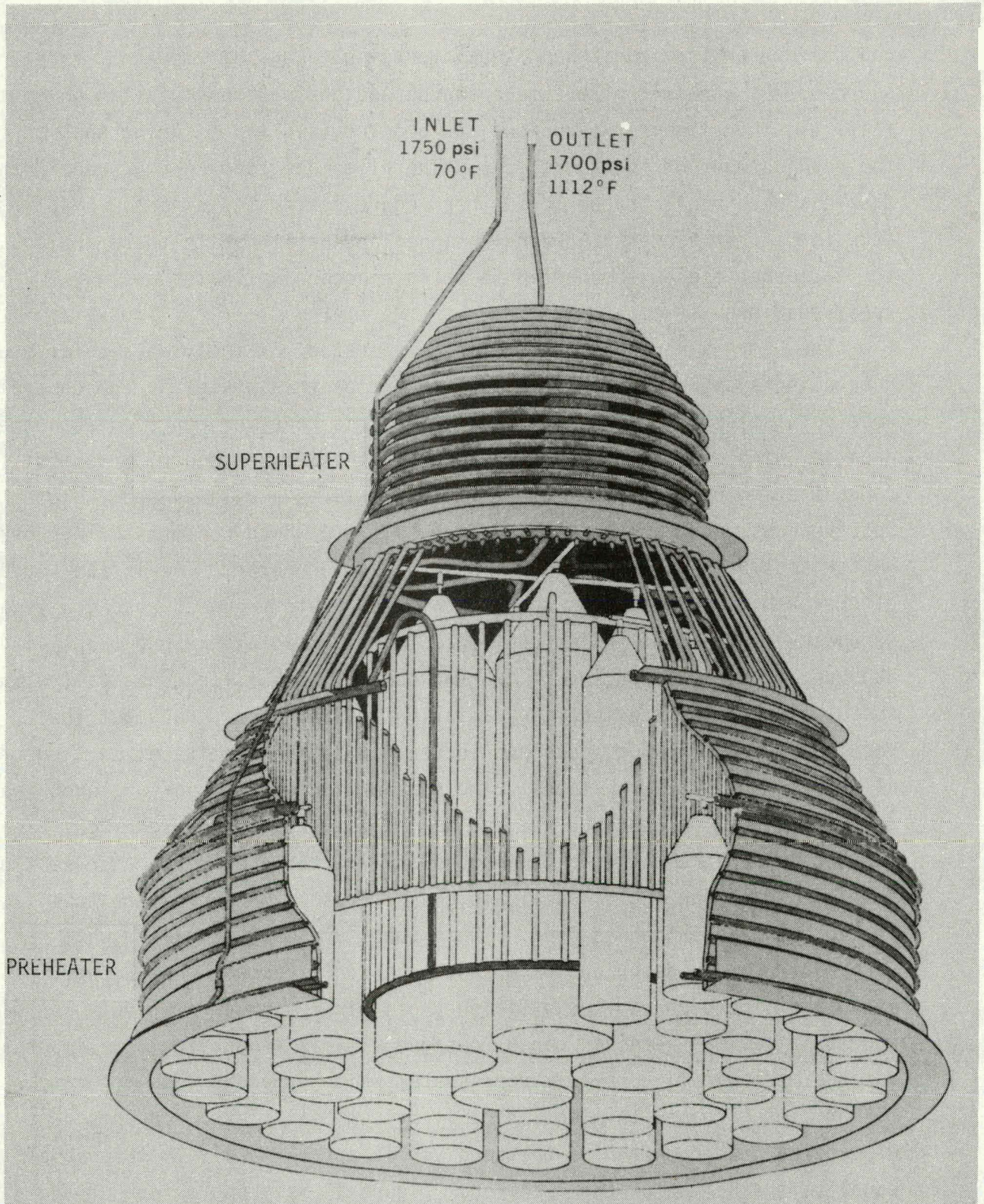

Figure 16. Cutaway View of Boiler-Superheater Cavity Receiver of the DOE Advanced Components Test Facility - Georgia Tech - Designed by Professor Francia.



Figure 17. Photograph of Boiler-Superheater of the DOE Advanced Components Test Facility at Georgia Tech - Designed by Professor Francia.

receiver at St. Ilario, Italy (Figure 13) Professor Francia reported a cavity efficiency of 90 percent.

2. Japan

As part of Japan's "Project Sunshine" is the development of solar power plants. Both a distributed system utilizing a plane-parabola concept and a central receiver system are being developed. The plane-parabola system is being developed by Hitachi, Ltd. in Tokyo and the Tower system by Mitsubishi, Hiroshima, Japan. The pilot plants will be constructed at Nio Town, Kagawa Prefecture, Shikoku, Japan. This section describes the test models which are being constructed in support of these systems.

a. Plane-Parabola System. Figure 18 is a schematic representation of the concept being developed for the plane-parabola collector system being

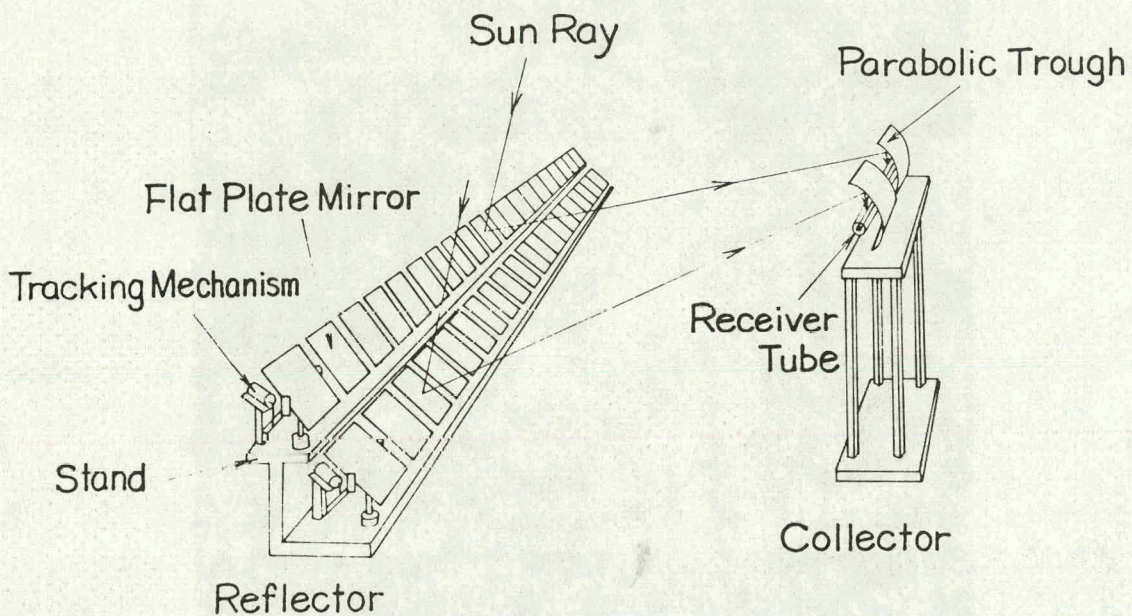

Plane-Parabola Solar Collector Model

Figure 18. Drawing of Plane-Parabola Solar Collector Developed by Hitachi, Tokyo, Japan.

developed by Hitachi 12/. Five rows of 20 flat mirrors, each 3.0 x 1.5 meters will be used to track the sun and direct its radiation onto five parabolic trough concentrators each 3.5 meters wide and 4.0 meters long. Each paraboloid trough in turn concentrates the solar radiation onto an absorber tube 0.054 meters in diameter surrounded by an evacuated glass tube envelope. This system is designed to provide a concentration ratio of 152. Twenty of the above units (each unit containing 100 flat mirrors and five parabolic trough concentrators) will provide a total flat mirror reflector area of 9000 square meters. This system is expected to provide 6300 Kg/hr of steam at 15 atmospheres and 343⁰ C to power a steam turbine to produce 1000 kW of electric power. The pilot plant using this concept will be only 30 percent of the 1000 kW system and is scheduled to begin operation in July 1980.

b. Tower System. Figures 19-21 are photographs of the concentrating solar energy test apparatus built by Mitsubishi Heavy Industries, Ltd., Hiroshima Technical Institute, Hiroshima, Japan 13/. This system was developed in support of the Japan Solar Tower program. Figure 19 is an overall view of the facility which provides about 40 kW of thermal power. It consists of a test tower 15 meters high, 88 heliostats each of which contain nine flat mirrors each 35 x 35 centimeters square (giving a total mirror area of 97 square meters), a test receiver and thermal loop.

This system was constructed during 1976, and has been used to evaluate both air cooled and steam receivers. Figure 20 shows the heliostat used in this facility. Although somewhat different in design, it operates on the same principle as the kinematic motion device developed by Professor Francia in Italy (Figure 15). Figure 21 is a photograph of the test receiver. Data obtained with this receiver predict an absorbing efficiency of 78 percent would be achieved at a heat flux of 170 kW/m^2 and a surface temperature of 300° C .

The 1000 kWe pilot plant which will be based on this facility will use 850 heliostats with a total mirror area of 13,600 square meters (4 x 4 meters per heliostat). The heliostats will be arranged in a circular field 160 meters in diameter. The steam receiver will be located on the top of a cylindrical tower, 68 meters high and produce 12,000 Kg/hr of steam at 40 atmospheres and 248° C . The turbine will use 9790 Kg/hr of steam at 12 atmospheres and 187° C . The 1000 kWe tower system is scheduled to start operation in November 1980 14/.

3. France

Many experimental efforts are underway in France to study and demonstrate the use of concentrated solar energy in solar thermal conversion systems. Most of these are associated with component development, i.e., receiver, heliostat, storage, etc., and are part of one of various national programs which are discussed in Section III. There is, however, one relatively large system which has been constructed and which is undergoing test and evaluation. This is a tracking solar concentrator-receiver unit developed by J.-L. Pierrier, Angers, France 15/. Figures 22 and 23 are photographs of

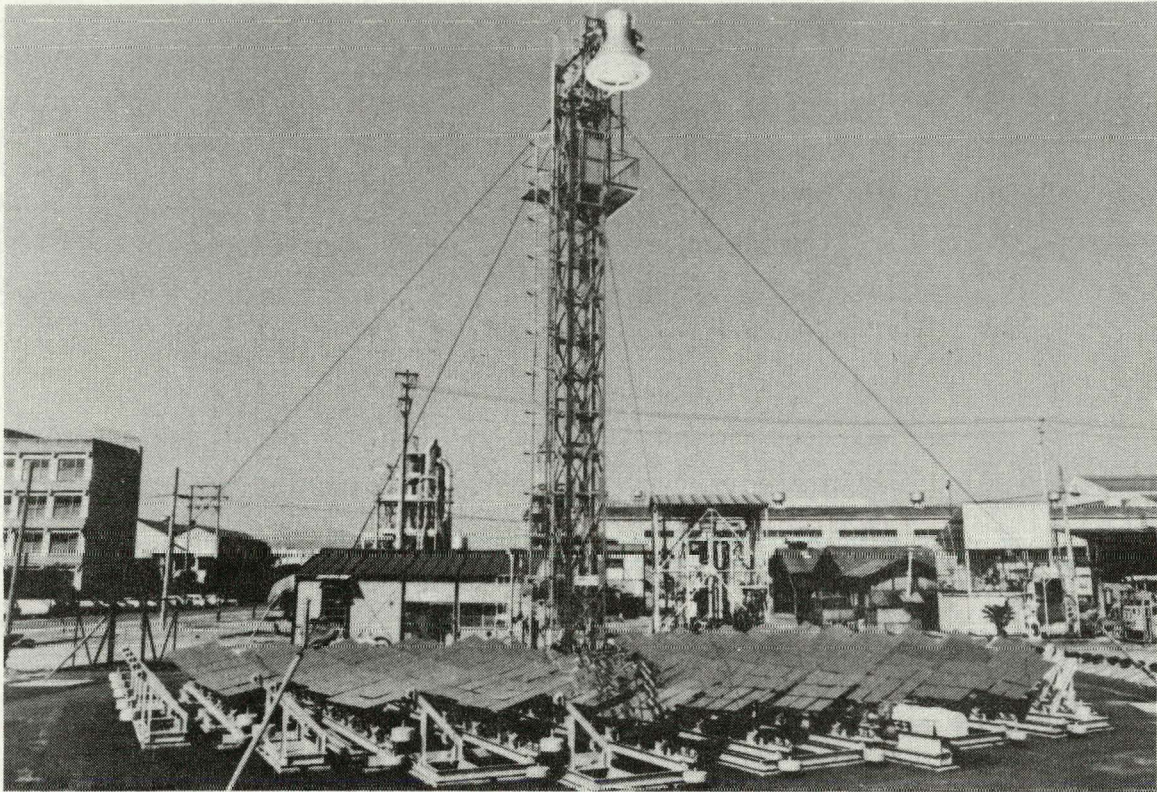

Figure 19. Central Receiver Test Facility Developed by Mitsubishi Heavy Industries, Hiroshima, Japan.

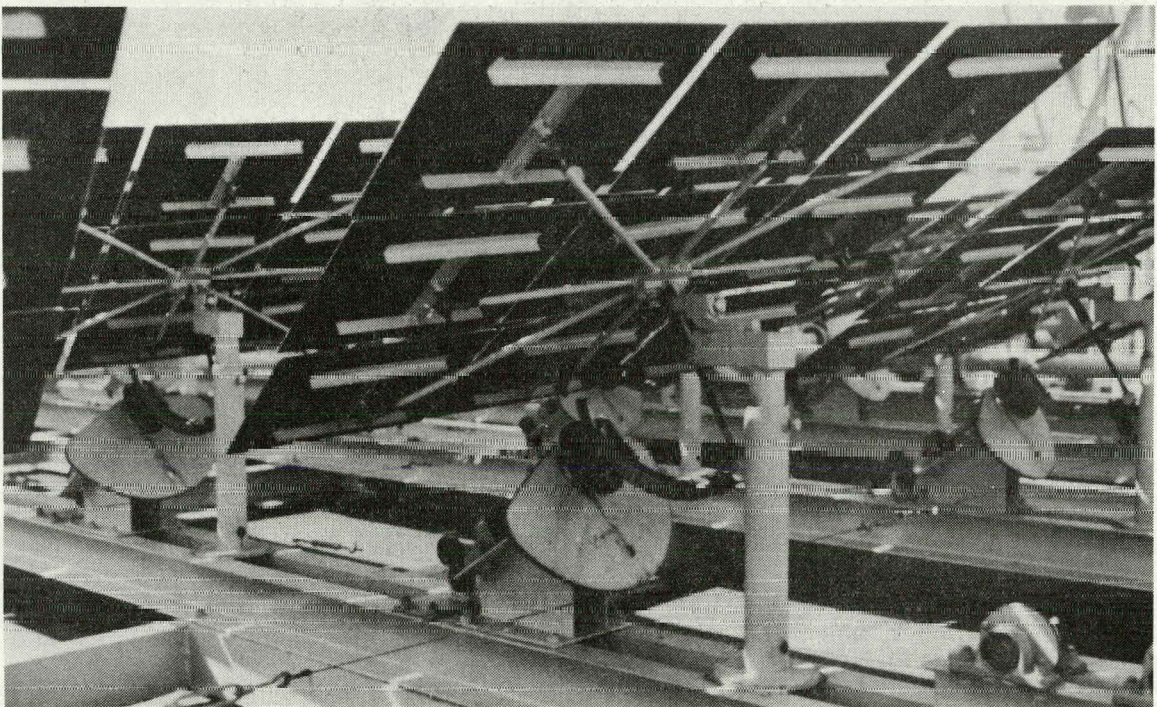

Figure 20. Heliostat Design Used in Central Receiver Test Facility Developed by Mitsubishi Heavy Industries, Hiroshima, Japan.

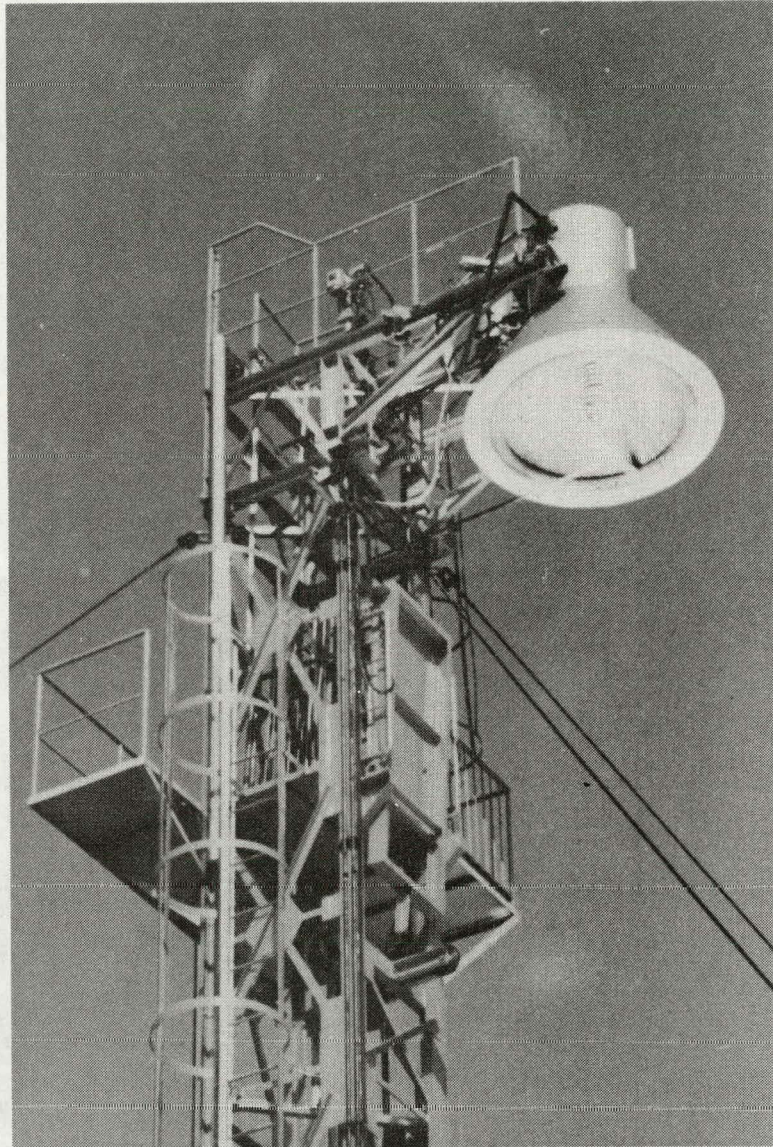

Figure 21. Photograph of Test Receiver at the Central Receiver Test Facility Developed by Mitsubishi Heavy Industries, Hiroshima, Japan.

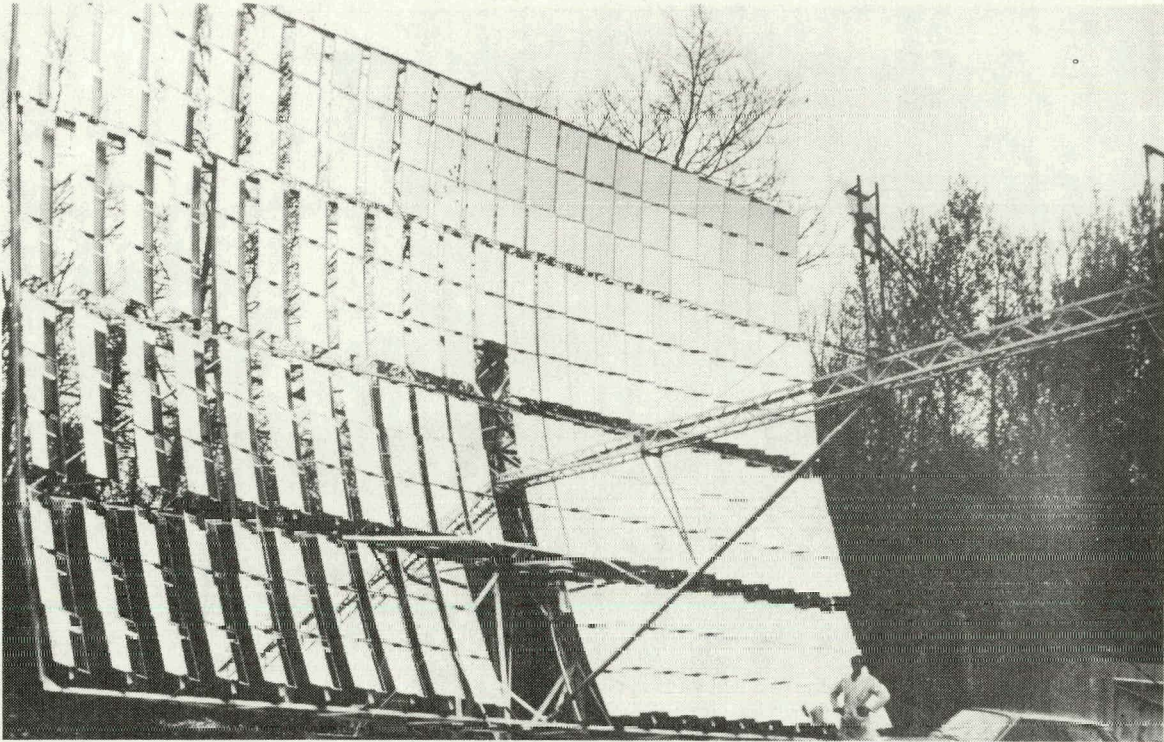

Figure 22. Tracking Concentrating Collector-Receiver Solar Power System of J.-L. Pierrier, Angers, France.

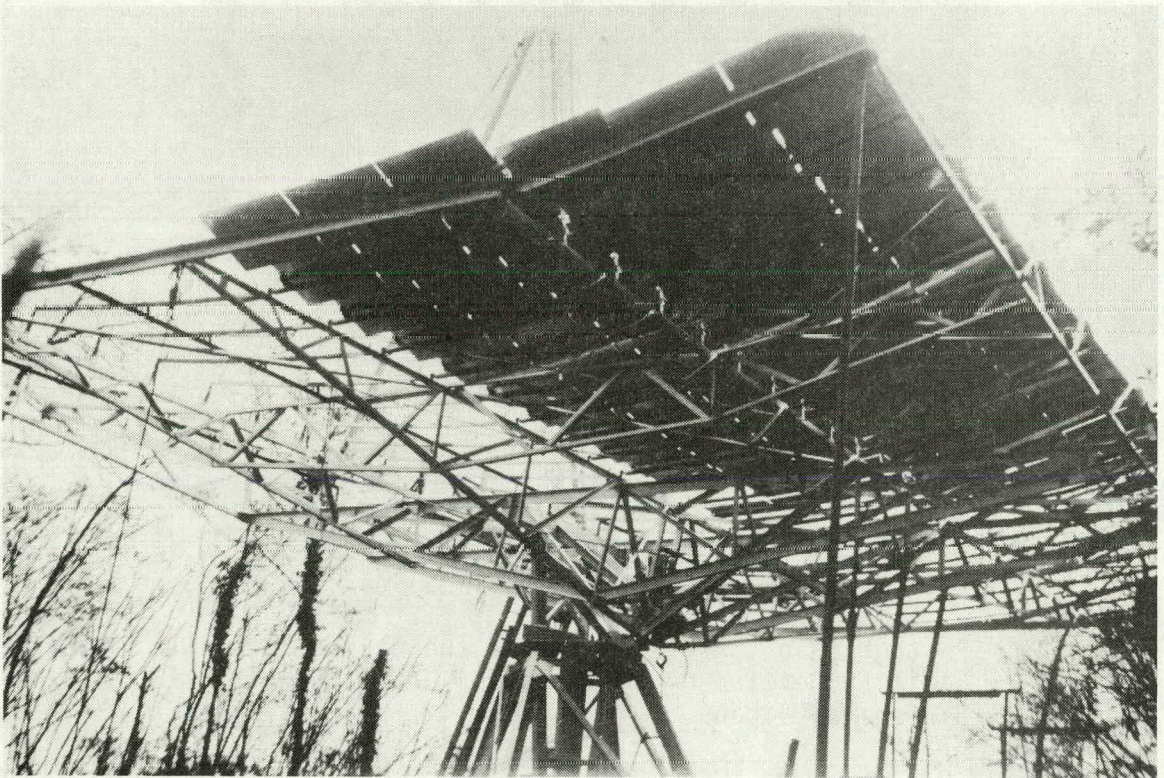

Figure 23. Supporting Structure of Tracking Concentrating Collector-Receiver Solar Power System of J.-L. Pierrier, Angers, France.

this system. The overall dimensions of the concentrator are 8.6 meters high by 12 meters wide. The concentrator contains 263 second surface silvered mirrors. The thermal power collected by this system is about 50 kW_t. The concentration ratio is of the order of 200, but this has not been measured with precision. Tracking is provided by small three phase AC motors which are actuated by altazimuth signals from five photo-resistance cells used to acquire the position of the sun. The focal zone is located approximately five meters from the plane of the concentrator.

The first phase of the experimental program which was to construct the collector/concentrator system has been completed. The second phase concerns the utilization of the concentrated energy. Presently an oil cooled receiver is being considered which will use Gilotherm TH at 340⁰ C with a secondary heat exchanger to provide steam at 25 atmospheres.

This system is considered important for this paper since there appears to be growing interest in smaller self-contained solar power systems. These may be used alone in certain small power applications (5-10 kWe), for example, in developing countries, or used in multiple units for the production of larger quantities of power as in certain total energy system. In that connection this system is typical of the type which might be considered in order to extend the small-power, stand alone system beyond the power level provided by readily available tracking paraboloid dish concentrators.

C. Major Solar Thermal Conversion Experiments

Two major experiments have been conducted to evaluate cavity type heat exchanger receivers for central receiver solar power systems: (1) a solar steam generator, and (2) an oil cooled receiver. Both receivers were evaluated using the CNRS 1000 kWt Solar Furnace at Odeillo, France.

1. Solar Steam Generator

A one megawatt cavity type solar steam generator was designed and constructed by the Martin Marietta Corporation 16/. The receiver design was based on the concept of a cavity receiver facing an all north field of heliostats. Therefore, from orientation considerations this receiver was well suited for testing at the Odeillo facility since the axis of the

paraboloid concentrator is essentially horizontal. However, the receiver was designed to accept radiation over a maximum view angle of about 90 degrees while the energy arrives at the focal point of the solar furnace from a maximum viewing angle of about 150 degrees. Therefore, it was necessary to design and build a flux redirector to intercept the wide angle radiation and redirect it into the receiver at more suitable angles. This redirector concept is shown schematically in Figure 24. Figure 25 is a photograph of the flux redirector being set up at the focal point of the solar furnace. The development and fabrication of the flux director was carried out at Georgia Tech. After a number of experiments using a 60-inch searchlight type solar furnace a suitable reflector surface was developed. This consisted of a base material of polished copper, nickel plated for hardness, repolished and coated with evaporated aluminum to provide a front surface mirror. The entire reflective cone was then provided with a water cooling jacket. The solar test program was conducted during June through August 1976. Figure 26 is a photograph of the Martin Marietta steam generating cavity receiver and flux redirector during test at the CNRS 1000 kW Solar Furnace. The successful performance of the flux redirector suggests that this materials system might serve as a starting point to use in designing high temperature secondary concentrating collectors.

2. Oil Cooled Receivers

During October-December 1976, the CNRS successfully demonstrated the production of electric power using the 1000 kW Solar Furnace at Odeillo 17/. In this system the receiver was used to heat oil which was fed to a storage tank. Hot oil drawn from the storage tank was used to generate steam through a series of heat exchangers. The steam in turn powered a turbogenerator which provided electricity to the power grid at Odeillo. A schematic of the Odeillo Power Plant is shown in Figure 27. The peak electric power provided by this system was 100 kW.

The receiver was designed to operate essentially as a black body with solar radiation entering the cavity through a relatively small aperture. The working fluid, Gilotherm, a high temperature oil (therphenyl hydrogen) circulated in a single spiral tube which formed the inside wall of the receiver.

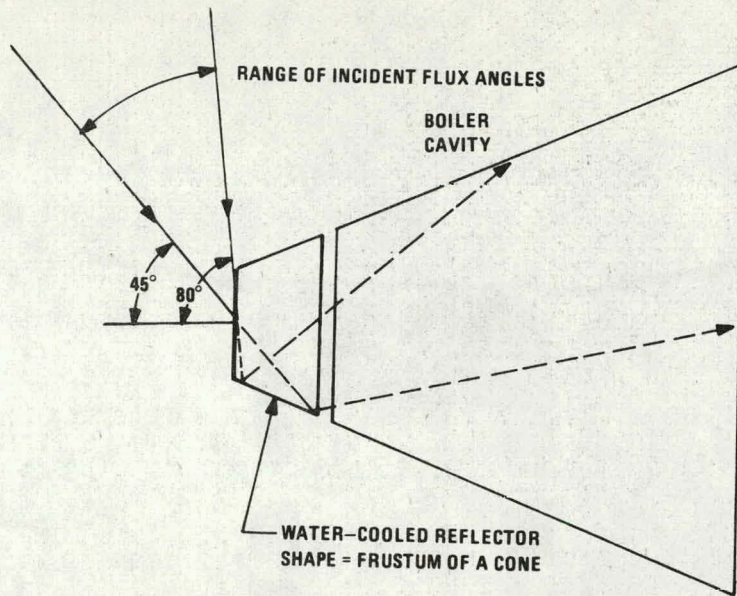

Figure 24. Schematic Showing Function of Flux Redirector Used With Martin Marietta Cavity Receiver at CNRS 1000 kW Solar Furnace, Odeillo, France.

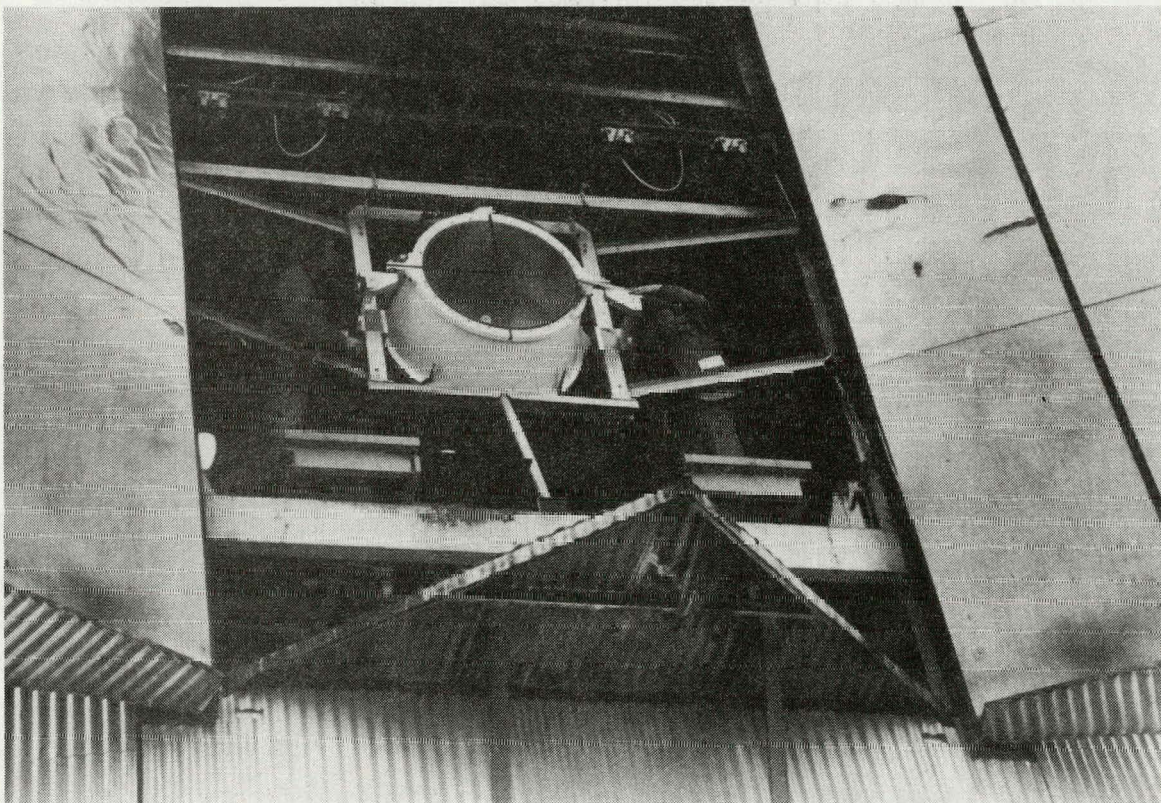

Figure 25. Flux Redirector Being Set-Up at CNRS 1000 kW Solar Furnace, Odeillo, France.

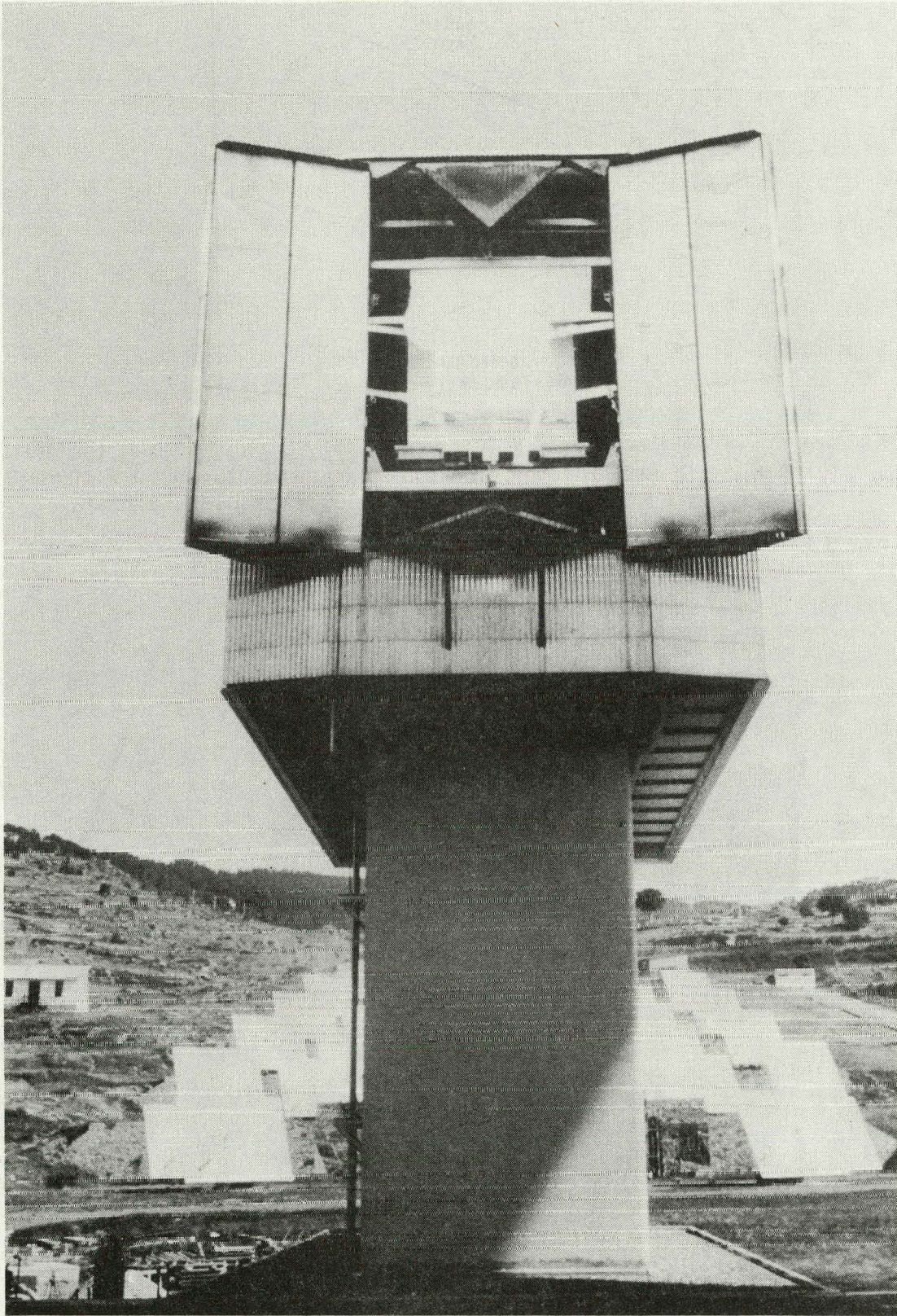

Figure 26. Martin Marietta Cavity Receiver Undergoing Test at the CNRS 1000 kW Solar Furnace, Odeillo, France.

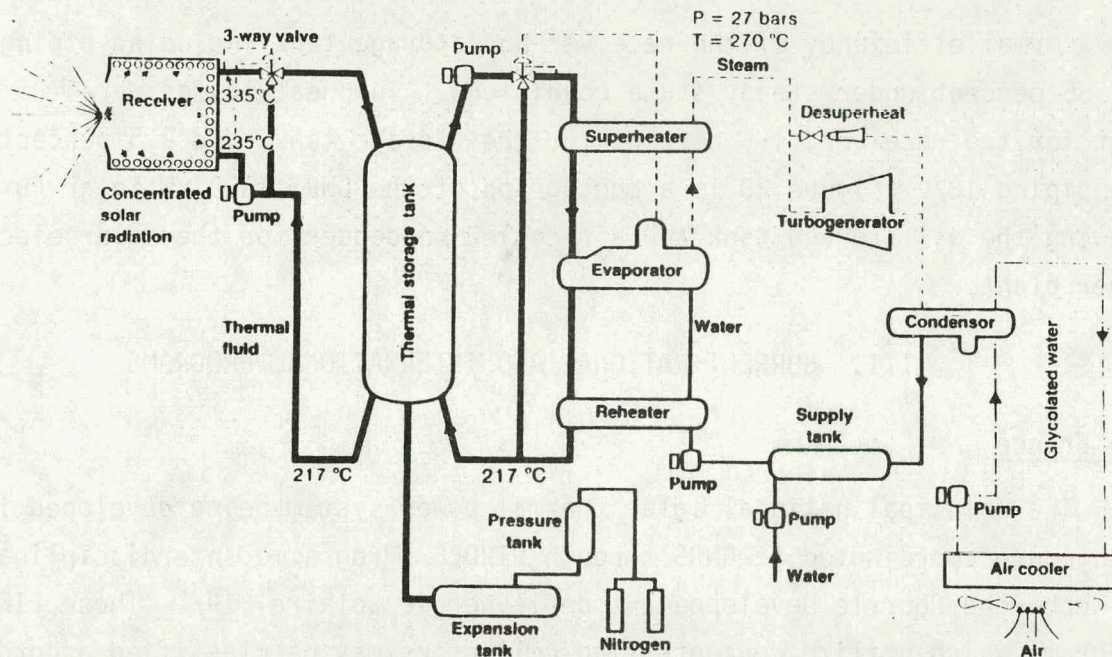

Figure 27. Schematic of Solar Thermal Power Cycle Using Oil Cooled Receiver at CNRS 1000 kW Solar Furnace, Odeillo, France.

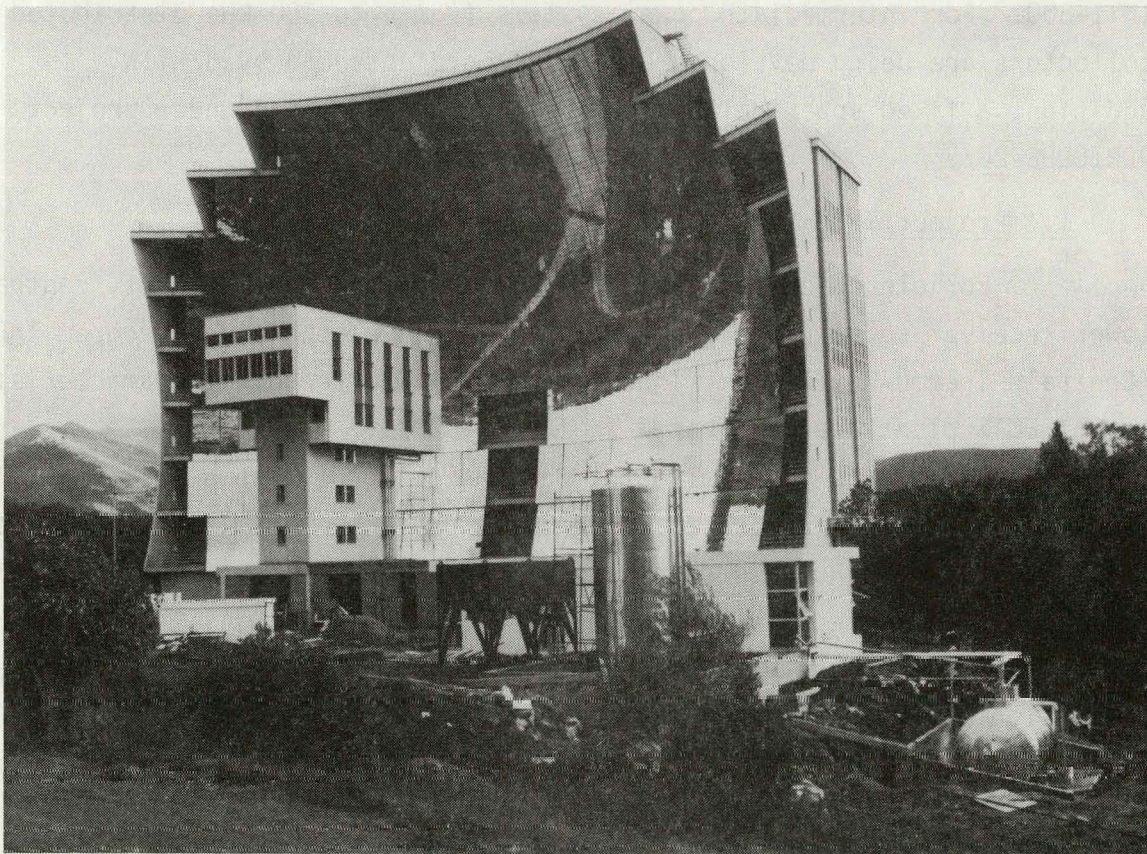

Figure 28. Oil Storage Tanks and Auxiliary Equipment for Oil Cooled Receiver Experiments at CNRS 1000 kW Solar Furnace, Odeillo, France.

The thermal efficiency of the receiver and storage tank including piping was 85 percent under steady state conditions. The heat losses were: 5 percent for the receiver, 1.5 percent for the storage tank, and 9.5 percent for the piping 18/. Figure 28 is a photograph of the CNRS 1000 kW Solar Furnace showing the oil storage tank and air cooled condenser for the solar electric power plant.

III. CURRENT NATIONAL AND INTERNATIONAL PROGRAMS

A. France

The principal national solar thermal power system being developed in France are coordinated at CNRS through PIRDES (Programme Interdisciplinaire de Recherche Pour le Developpement de l'Energie Solaire) 19/. Those PIRDES programs which utilize concentrating collectors may be classified according to type of collection system and design power output. For power levels above one MWe central receiver systems are being developed under projects THEM and INTI-800. For intermediate power systems from 5 to 100 kWe distributed collectors are being developed under THEK projects and by BERTIN. In addition, a fixed spherical collector is being developed under project PERICLES 20/.

1. Project THEM

For electric power production above about one megawatt, central tower receiver solar power systems are being developed under program THEM (Centrale Thermo-Helio-Electrique-Megawatt). The technical characteristics of a THEMIS plant are summarized in Table 4 20/.

Sketches of the four heliostat designs being developed on the THEMIS program are shown in Figure 29. The first prototype THEMIS is planned to begin operation at Hute-Cerdagne, France in 1980, and is a joint project of CNRS and EDF (Electricite de France). This project will be a continuation of the INTI 800 project which is being conducted by the industrial group CETHEL (an association for the construction of solar central receiver-heliostat type power plants). Participants in that program are St. Gobain-Pont-A-Mousson and Renault Engineering for the heliostat, Renault Engineering

TABLE 4
THEMIS PROJECT

Heliostat Field

- Approximately 360 heliostats placed north of a 100m tower
- Area of installed glass: 17,500 m²
- Ground area: about 6 hectares (15 acres)
- Nominal power received by the collectors is 14 MW (Solar flux of 800 W/m² at noon at equinoxes)

Heliostats

- Four prototypes are shown in Figure 29
- Area: approximately 50 m²
- Focusing
- Operating in winds up to 50 km/h
- Tracking precision: 4 millirad. in the reflected beam

Receiver

- Cavity type, 50 m² aperture, tube walls
- A molten salt receiver in which the storage fluid is heated indirectly

Storage

- Fluid: eutectic mixture of KNO₃, NaNO₂, NaNO₃ (53%, 40%, 7%)
melting point: 140⁰ C
- Storage temperature: 300-415⁰ C
- Capacity: 600 tons, distributed between two 400 m³ reservoirs

Cycle

- Water/superheated steam: 50 bars, 410⁰ c
- Nominal turbine power: 2 MW
- Output condensor: 60⁰ c, 0.2 atm

(Continued)

TABLE 4 (Continued)

THEMIS PROJECT

Conversion

- For nominal characteristics (800 W/m ² at noon at the equinoxes)	
- Collector field	0.95
- Glass	0.85
- Receiver	0.85
- Net cycle	<u>0.26</u>
Overall	18%

for the tower, Heurtey for the thermal system and Fives-Cail-Babcock for the boiler. The INTI 800 project will be operational in 1979, and will generate 800 KWe. Its thermal system is a scaled up version of that used in the Odeillo oil cooled receiver-electric power generation experiment described in the previous section (Figure 27). The 150 heliostats used in the INTI 800 project will be in principle those used in THEMIS.

The second generation of tower systems should lead to a 10-20 MWe power station in 1983, with an energy cost of 100 mils/kWh or less. This CNRS program is being conducted in liaison with EDF and with the cooperation of CEA (Commissariat a l'Energie Atomique) and the ONERA (Office National d'Etudes et de la Recherche Aerospatiale).

2. Project THEK

Project THEK (Thermo-Helio-Electrique-Kilowatt) is one of several CNRS projects to develop solar systems for power requirements below the megawatt level 21/. These projects use distributed collector systems made up of smaller and less sophisticated mirrors with concentration factors in the range of 20 to 300. Other distributed system programs besides THEK are PERICLES and the program of Bertin.

In the THEK program each solar thermal conversion module is made up of a parabolic collector which tracks the sun and has a receiver at its focus.

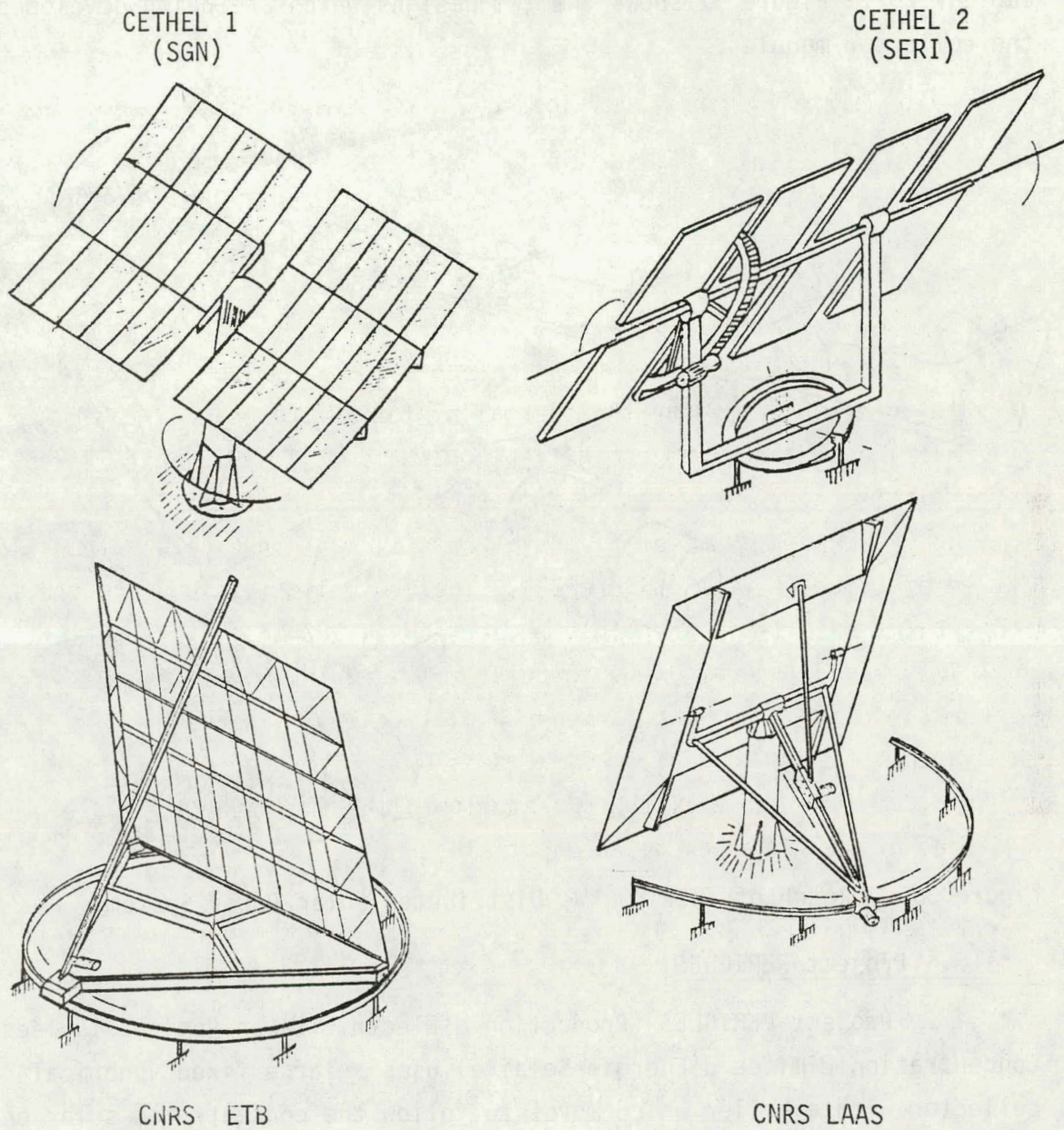

Figure 29. Four Heliostat Designs Being Developed on Project THEM and INT 800.

A thermal loop links all of the conversion modules to a common control and storage system. A sketch of the THEK 80 kWe facility to be completed in 1978, is shown in Figure 30, and its technical characteristics are given in Table V 20/. Figure 31 shows the two designs which are being developed for the collector modules.

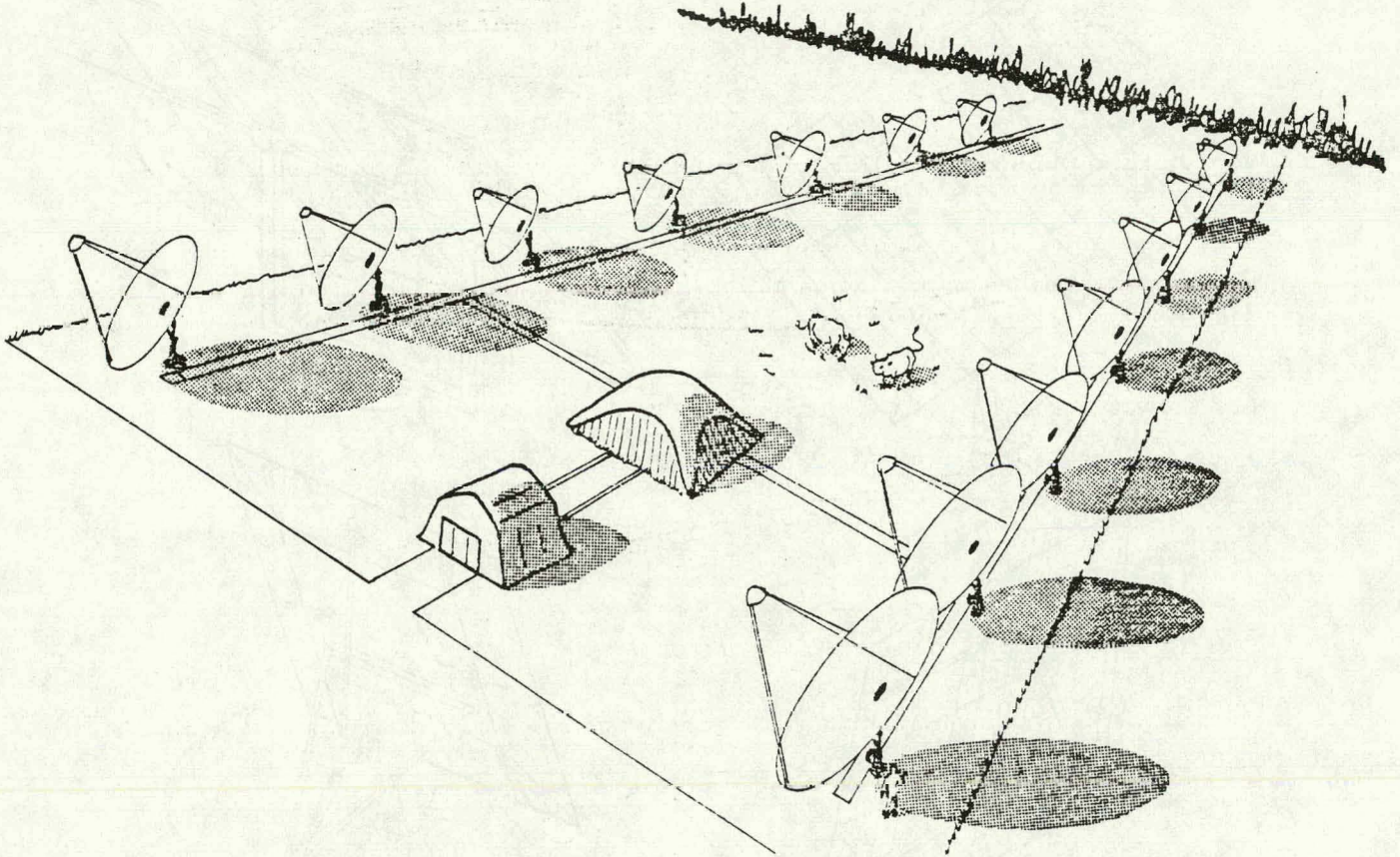

Figure 30. Sketch of THEK 80 kWe Distributed Solar Power System.

3. Project PERICLES

Project PERICLES (Production d'Electricité en Regions Isolées par Concentration Limitée d'Energie Solaire) uses a large fixed spherical collector with a boiler which moves to follow the concentrated solar energy produced in the collector. The receiver is divided into two sections, one roughly cylindrical which receives low concentration radiation and a cavity receiver for the high flux concentration. A 10 meter diameter laboratory mock up was completed in 1977 20/.

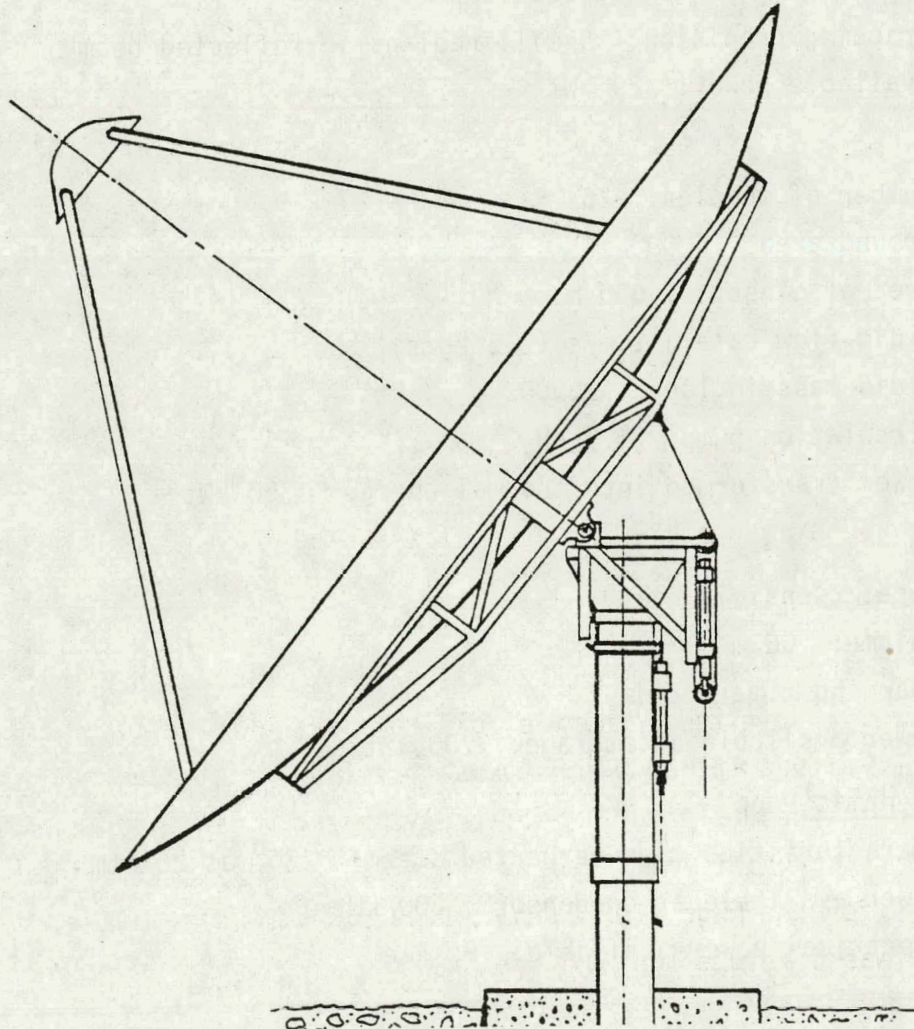
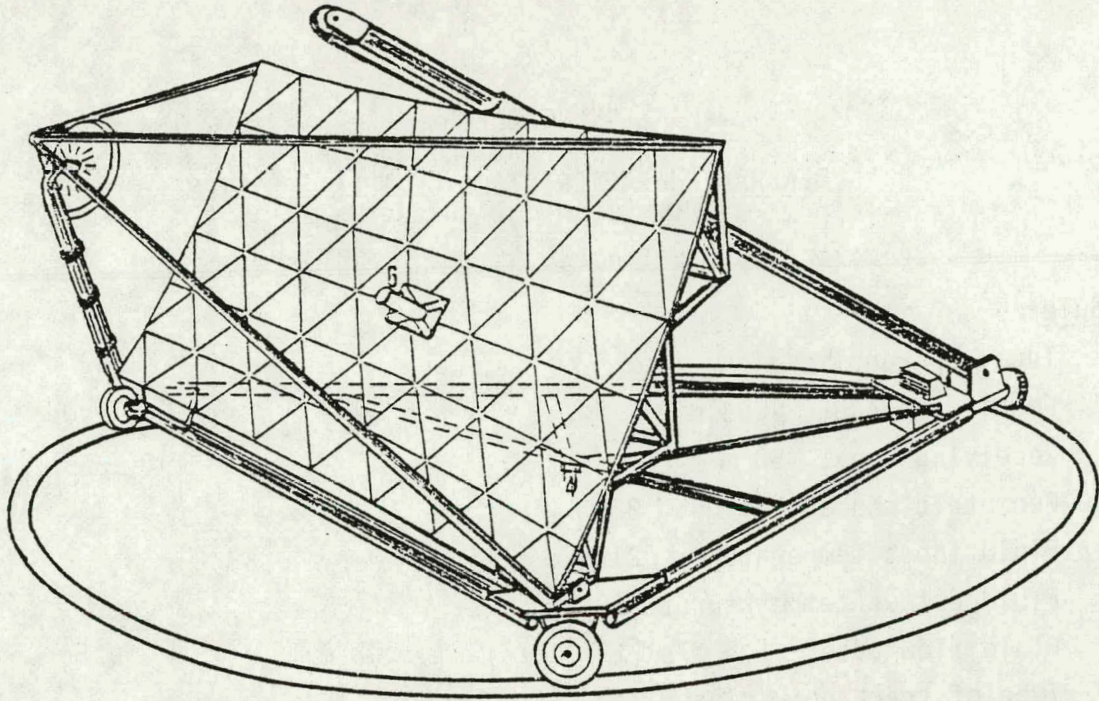

Figure 31. Concentrating Collector-Receiver Design Being Developed for THEK System.

TABLE 5
GENERAL CHARACTERISTICS OF THEK 2 SYSTEM

Module

Type: parabolic dish
Focal distance: 4.83 m
Receiving area: 50 m²
Geometric concentration: 230
Fluid input temperature: 217⁰ c
Fluid output temperature: 300⁰ c
Fluid flow rate: 1.5 m/s (124 kg/s)
Type of tracking: closed loop
Tracking precision: 5 milliradians in reflected beam
Available power: 29 kWt

System

Number of modules: 26
Ground area: 6,000 m²
Area of glass: 1,300 m²
Fluid flow rate: 1 m/s (3.5 kg/s)
Fluid mass in loop: 2,900 kg
Circulation pump: 1.5 kW
Power transformed into thermal energy: 750 kWt

Storage

Type: sensible heat
Volume: 56 m³
Charging time: 2 days
Power available at storage: 700 kWt

Thermodynamic Loop

Characteristics of superheated steam: 280⁰ at 26 atm
Power available at condensor: 600 kWt
Electrical power available: 93 kWe

For the reflecting surface of this collector a new fabrication technique was developed. Thin curved hexagonal glass sheets 60 cm diagonal were bonded to large self supporting mirror carriers 3 x 2 meters. These carriers were made of a lightweight mixture of emulsified concrete and small expanded glass beads. The curvature radius can be as small as 5 meters and developments are in progress to increase the dimensions of both elementary mirrors and mirror carriers 22/. A photograph of the 10 meter diameter model is shown in Figure 32. A 50-meter diameter version is currently planned with a concentration factor of 250 and an electrical power output of 250 kWe.

4. Bertin Company Project

The Bertin Company is leading a team of four members in the development of a medium size solar electric power plant in the 100-1000 kWe range 23/. The other members are Renault Moteurs Development, Commissariat a l'Energie Atomique and Pechiney Ugine Kuhlman.

Two kinds of linear focus solar collectors are being considered. The first uses a fixed boiler pipe and moving parabolic trough mirror set up in a greenhouse. The greenhouse provides dust, corrosion, and wind protection and permits the use of a much lighter solar collector structure. The second system is a segmented mirror fixed reflector built of silvered glass mirrors on concrete blocks in an east-west orientation. The heat collector is adjusted on solar declination, thus requiring a few degrees per day of scanning. Mirror blocks are designed for on site production. The system is being designed for 24 hour operation using oil storage heated directly from the collectors. Power will be provided through an organic cycle turbo-alternator.

Table 6 summarizes the status and some of the more important characteristics of the major French solar power systems being developed under the CNRS-PIRDES programs.

B. Japan

The major Japanese solar energy programs utilizing concentrating collectors are being developed under the national program "Project Sunshine."

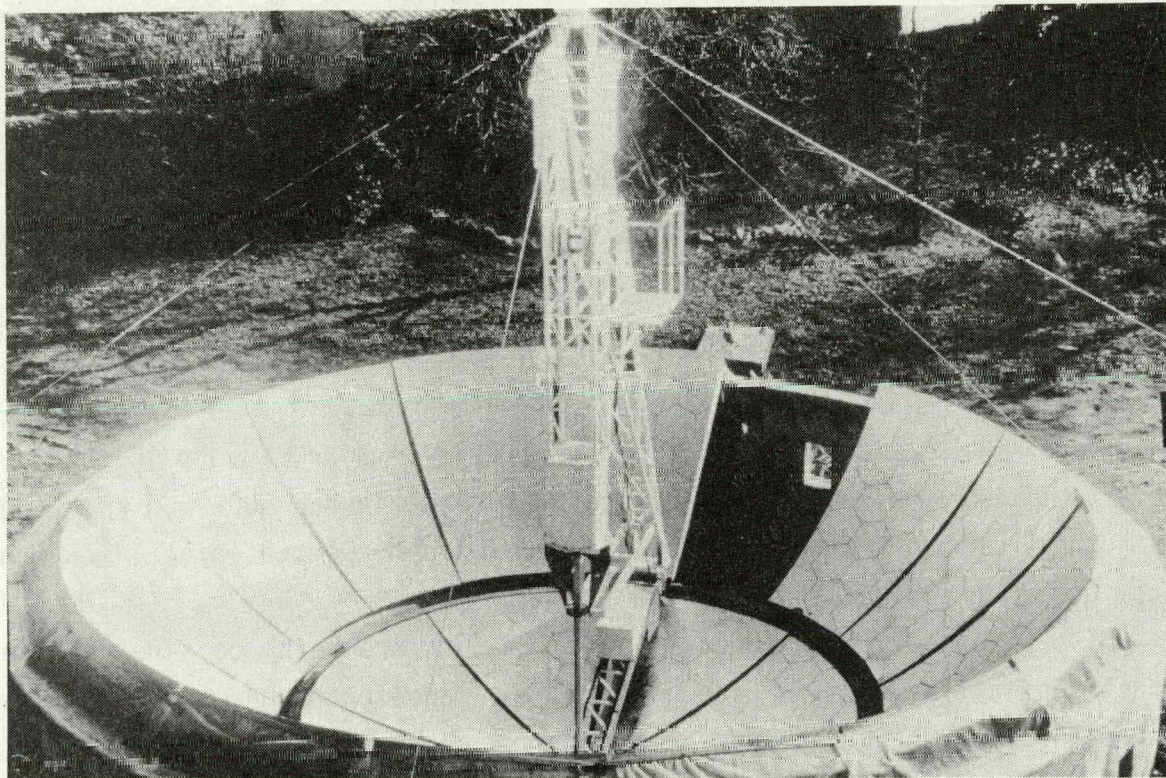

Figure 32. Photograph of 10 Meter Laboratory Model of PERICLES Fixed Spherical Dish Concentrator.

Inaugurated in July 1974, the objective of this program is to promote R&D on alternative sources of energy which might meet the energy demand of Japan after the year 2000 24/.

Mitsubishi Heavy Industries is developing a central receiver solar electric power plant concept in Japan. A one MWe plant is scheduled for completion in 1980 and its characteristics were briefly summarized in Section II.B.2. The general specifications for the 10 MWe plant planned for 1985 are similar to the DOE 10 MWe Pilot Plant project to be built at Barstow, California.

Hitachi, Ltd. is developing a distributed system utilizing a plane-parabola concept. A 300 kWe pilot plant, scheduled to begin operation in 1980 also is described in Section II.B.2.

TABLE 6

SUMMARY OF FRENCH SOLAR ELECTRIC POWER PROGRAMS USING CONCENTRATING COLLECTORS

Project	THEMIS	INT-800	THEK-1	THEK-2	PERICLES	BERTIN
	CNRS-EDF	Industry	CNRS	CNRS	CNRS-LAS	Industry
Date First Operated	1980	1979	1977	1978	1977	1979
No. of Heliostats	260 50 m ²	150 50 m ²	---	---	---	---
Concentrating System	---	---	2 ea Paraboloids	25 ea Paraboloids 50 m ²	Sphere	Paraboloid Trough or Segmented
Concentration	500-1000	300-500	250-300	250-300	250	21
Receiver Fluid	Molten Salt 420° C	Gilotherm 335° C	Gilotherm 300° C	Gilotherm 300° C	---	Gilotherm 200°-250° C
Storage Fluid	Molten Salt 420° C	Gilotherm 335° C	Gilotherm 300° C	Gilotherm 300° C	---	Gilotherm-Rocks 200°-250° C
Working Fluid	Steam 410° C-50 atm	Steam 270° C-27 atm	Water- Steam	Water- Steam	---	Organic Fluid 200°-250° C
Conversion Device	Turbine	Turbine	Piston Motor Spilling	Turbine	---	Turbine
Power Delivered KWe	2,000	800	5	80	8	200-300

Other major projects include the 40 kW_t high temperature solar furnace of the University of Tohoku at Sendai and the 40 kW_t solar thermal test facility of Mitsubishi at Hiroshina, Japan. These facilities were described in Section II.A.3 and II.B.2, respectively.

C. Federal Republic of Germany

In contrast to the situation in some other countries there was essentially no background in concentrating collector technology in West Germany prior to 1973. However, this situation has changed dramatically during the past four years. Most activities in the Federal Government are joint industry-government projects and Germany has become particularly active in international cooperative programs 25/.

An association between Messerschmidt-Bolkow-Blohm (MBB) and the Italian firm Ansaldo was formed to develop solar electric power plants of two types. One is a scaled up version of the central receiver plant design by Professor Francia at St. Ilario (see Section II.B.1), the other is a 100 kWe system of a design similar to the one being developed by J. L. Perrier 15/.

A 10 kWe power system using concentrating collectors is being developed by Dornier Systems 26/. This plant is being designed to provide electricity to small villages for pumping water for irrigation, running of small machines and for communications and is being supported by the Ministry of Science and Technology of the FRG with the assistance of the National Research Center (NRC) of Egypt. The system will use 400 square meters of flat plate collectors and 200 square meters of tracking parabolic trough concentrators to heat water in the primary cycle. The collected energy is transferred to a secondary cycle in which Freon R113 is vaporized to drive a turbogenerator. The overall efficiency of the plant is calculated to be about 3 percent and it is expected to begin operation in 1978.

M.A.N. Corporation of Munich is developing a small scale modular solar thermal power station with a capacity of 15 to 1000 kWe using concentrating collectors with steam as the working fluid 27/. The collector module consists of a platform of approximately 150 square meters of collector area oriented in a north-south direction. A prototype power plant with a maximum output of

50 kWe and with integrated waste heat utilization will be erected in Spain in 1978/79. It will use parabolic trough concentrators with a concentration factor of 30-40 to produce a working fluid temperature of 250⁰-300⁰ C to drive a steam turbine. One collector platform of 150 square meters was scheduled to be installed in early 1978 with the total system being operational in early 1979 (see Section III.G.2.).

Numerous concentrating collector devices are being studied, developed and demonstrated by the Research and Development Laboratory of Hans Kleinwächter in Lörrach. Of interest to this review is a single axis tracking, polar axis mounted paraboloid dish concentrator. Solar thermal systems with dish diameters up to 8 meters are being designed with a projected total system cost as low as \$13,500 for a 5 kWe unit 28/.

D. Spain

Spain's official activities in the field of solar energy were initiated in 1958 when the Comision National de Energias Especiales (CNEE) was appointed to study the potential of non-conventional energies. The main solar projects involving concentrating collectors within the CNEE program are: (1) a solar thermal plant (boiler) capable of producing 1000 Kg/h of steam at about 145 atmospheres coupled to a conventional thermoelectric power plant, (2) a 1 MWe central receiver solar electric power plant, and (3) a 30 kW_t solar furnace for materials research 29/.

The 1 MWe central receiver solar power plant is being constructed at Almeria in Southern Spain and is scheduled to begin operation in 1980. This plant will use 600 heliostats each with a surface area of 10.667 square meters. A semi cylindrical cavity type boiler-superheater receiver will be mounted on a tower 30 meters high. The thermal power is predicted to be 5.15 MW_t 30/. With this pilot plant Spain expects to be among the first countries to demonstrate the use of solar energy for the large scale production of electricity. The selection of Spain for the two IEA (International Energy Agency) 500 kWe solar electric power plants adds further support to Spain's efforts to be one of the leading countries in the development of solar electric power.

E. Italy

The most significant accomplishment in concentrating collector development in Italy has been the work of Professor Francia previously described (Section II.B.1.). However, at the present time numerous individual industrial and university activities are rapidly developing throughout the country. Unfortunately these activities are not being coordinated and a national solar energy program has yet to be developed. Probably one of the most active laboratories is that of the University of Calabria 31/ at Cosenza in southern Italy where a linear parabolic trough concentrator is being set up in a greenhouse (similar to the Bertin project in France). A cooperative project with Fiat has the objective of developing low cost linear concentrators using curved plexiglass sheets backed with aluminized mylar to make a second surface mirror.

Sicily has been selected as the site for the EEC (European Economic Community) 1 MWe central receiver solar electric power plant.

F. Multi National Programs

Two major multi-national programs are making significant contributions to the advancement of concentrating collector technology. These are the solar power plant of the European Economic Community (EEC) and two power plants of the International Energy Agency (IEA).

1. European Economic Community (EEC)

The EEC is proceeding to build a 1 MWe central receiver type solar power plant near Catania in Sicily. This facility will use 250 heliostats, designed by MBB (FRG), with a total mirror area of 7,000 square meters. The receiver will be a cavity type boiler-superheater, similar to the design of Professor Francia, on a 50-meter tower. Steam conditions will be 510⁰ C at 50 atmospheres. Storage will consist of a steam-water accumulator with a molten salt sensible heat superheater 32/.

2. International Energy Agency (IEA)

The IEA is constructing two 500 kWe solar power plants in southern Spain. One will be a distributed system and the other a central receiver

system. Acurex of California is providing most of the solar input for the distributed system and Martin Marietta, Denver Division most of the solar input for the central receiver system 33/. The M.A.N. (FGR) two-axis tracking concentrating collector will be used on 30 percent of the field for the distributed system. Various heat transfer fluids were studied for the central receiver system including molten salts, sodium vapor and liquid sodium, with liquid sodium having been selected for this application 34/.

IV. CONCENTRATING COLLECTOR ACTIVITIES IN LESS DEVELOPED COUNTRIES (LDCs)

During the past decade mounting concern has developed over the problem of meeting the energy needs of the less developed countries. Development requires energy and most of the LDCs are unable to afford conventional sources of energy, and are poorly equipped for its transport and/or distribution even if they could afford them. However, since most of these countries are in areas of high solar insolation and since solar energy is naturally distributed attention has been turning to solar energy as one of the most promising sources of energy for the LDCs.

The principal requirements for energy in less developed countries are mechanical power for pumping irrigation water and for generating electricity, and thermal energy for drying agricultural products, for industrial processes and for cooking. Since it is well known that solar energy can meet all of these requirements, there has been a rapid increase in solar energy R&D in almost all of the LCDs. However, until recently most of these activities have been concerned with the development and evaluation of systems using flat plate, non-concentrating collectors. Recently it has begun to be recognized that the very low efficiencies (about one percent) obtained with such collectors makes these systems prohibitively expensive. Therefore, many of the less developed countries are beginning to experiment with the use of concentrating collectors. Such collectors typically are being developed for water pumps and cooking since typically these countries are situation in arid climates where irrigation water is badly needed and where fuel wood is in short supply. The lack of water for crops and animals and excessive cutting of wood for cooking have compounded the energy problem by adding an extra

burden to the land which is resulting in deforestation and desertification. Therefore, by developing efficient, reliable and affordable solar concentrators it would be possible not only to provide the energy so urgently needed for water pumping and cooking, but would help in the fight against deforestation and desertification 35/.

Activities in four of the less developed countries are given here as examples of the types of programs that may be expected from the LDCs and through which they are likely to make significant contributions to concentrating collector technology in the near future.

A. India

The solar energy activities in India are the most numerous and diversified of any of the less developed countries. The Indian solar thermal conversion program gives top priority to water pumps for irrigation. Those using concentrating collectors are: (1) a 200 watt hot air engine using a tracking concentrator and Sterling cycle at Bhavanagar, and (2) a 2 KW pump using fixed linear parabolic concentrator and steam Rankine cycle at Baroda 36/. Other concentrating collector programs include solar furnaces at the Indian Institute of Science and Vikram Sarabhai Space Center, paraboloid collectors at the Annamalai University and solar cookers at the National Physical Laboratory, the Central Arid Zone Research Institute and the Annamalai University. All together there are more than thirty Centers of solar energy research in India. At the 1977 International Solar Energy Congress in New Delhi, researchers presented 15 papers dealing with concentrating collectors.

B. Mexico

The Institute of Engineering of the National University of Mexico has undertaken a program to develop a small power station for remote districts with an underdeveloped infrastructure and insufficient energy supply 37/.

A 1 KW prototype water pumping system was constructed as part of a program to develop a 20-40 KW system. The system uses 30 square meters of linear parabolic trough concentrators. Experimental collectors were oriented in N-S and E-W directions. The N-S collectors rotate around the absorber and

in the E-W system both the collector and absorber rotate simultaneously around the center of gravity which is below the system. Four different reflective materials are being evaluated. Preliminary experiments have shown that second surface aluminized acrylic and vacuum deposited aluminum on polished stainless steel with acrylic coating give the best reflectivity with both having a value of about 0.8. The thermomechanical system uses steam at 170⁰ C and 3 to 5 atmospheres as the working fluid to drive a steam piston engine. This system has been connected to a pump in a shallow water well and is currently undergoing evaluation.

C. Egypt

Several concentrating collector projects are being carried out at the National Research Center (NRC) near Cairo. The more significant ones are concerned with steam generation using point focusing systems. Figure 33 is a photograph of a large scale solar furnace under construction at the NRC 38/. The framework for the concentrating collector mirrors is at the left. The three heliostat frames are shown in stair step fashion at the right. The three level construction was necessary because of the low latitude of Cairo and the high tilt angle required during the summer. This is a reminder that the heliostat-concentrator type of solar furnace becomes a marginal design concept as the site location approaches the area between the Tropic of Cancer and Capricorn. This is also a reminder that caution must be exercised when considering the direct transfer of solar devices from one area of the world to another.

D. Niger

Solar energy programs in Niger are carried out through ONERSOL (l'Office de l'Energie Solaire) in Niamey. Those involving concentrating collectors are related to developing cookers and thermomechanical power generation equipment. Figure 34 is a photograph of a paraboloid dish solar cooker produced by ONERSOL. Similar cookers introduced into Upper Volta have been used by village women to prepare all of their native dishes including broiled chicken. The low cost, ease of operation, simplicity and versatility give this cooker the potential of being able to significantly reduce the



Figure 33. Construction of Solar Furnace Test Facility at National Research Center, Cairo, Egypt.

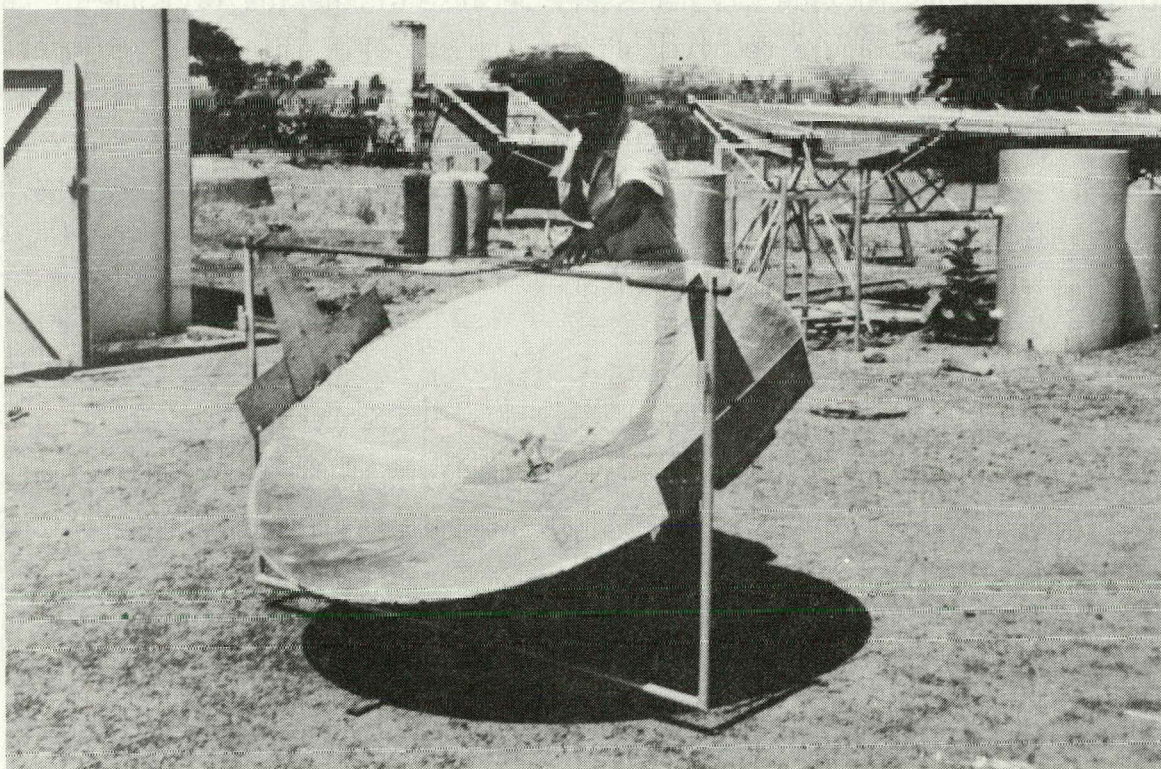

Figure 34. Concentrating Collector Solar Cooker at ONERSOL, Niamey, Niger.

deforestation caused by the excessive cutting of firewood for cooking. Of major importance in the potential success of this cooker is the relatively large collector area (about two square meters) needed to cook sufficient food for a family of four to six and the use of aluminized plastic reflector which is easily cleaned.

V. CONCLUSIONS

International developments in concentrating collector technology cover a broad range of applications over a relatively long period of time. Developments in high temperature technology in Europe, Algeria and Japan provide a background of experience and technology which should assist future developments in the United States concerned with high temperature chemistry and materials processing.

The developing programs in solar thermal electric power generation in France, Italy and Spain will provide much needed information concerning the performance of various types of collector-concentrator systems, heat transfer fluids, and receiver designs as well as the effect of different geographic locations and climates on performance and economics.

Activities in less developed countries provide information concerning energy needs and circumstances very different from those of the United States. They suggest a new area for applying existing technology to meet small, dispersed primarily thermal energy needs where simplicity, reliability and minimum cost are paramount. They identify a potentially large market to challenge U. S. industrial know how. Also, because of the large number of laboratories becoming involved in collector technology throughout the less developed countries the LDCs provide a future resource of diverse activities from which new and innovative ideas are likely to come.

THIS PAGE INTENTIONALLY LEFT BLANK

VI. REFERENCES

1. Antoine Laurent Lavoisier, "Premier essai du grand verre ardent" Mémoire de l'Académie Royale des Sciences, 1782, p 62.
2. K. S. Salariya, "Solar Concentrators" Extended Abstracts, Vol. 2, ISECC 77 International Solar Energy Congress, New Delhi, India, 16-21 January 1978, pp 922-924.
3. V. B. Veinberg, Optics in Equipment for the Utilization of Solar Energy, State Publishing House of Defence, Moscow (1959).
4. J. I. Yellott, "Captain John Ericsson: Pioneer in Solar Energy" The Sun at Work in four parts, Vol. I, No. 3, Sept. 1956, pp 6-13; Vol. I, No. 4, Dec. 1956, pp 8-14; Vol. II, No. 1, March 1957, pp 10-14 and Vol. II, No. 2, June 1957, pp 12-15.
5. F. Trombe, "Les Installations de Montlouis et le Four Solaire de 1000 kW d'Odeillo-Font-Romeu" Colloques Internationaux du Centre National de la Recherche Scientifique, No. LXXXV, Applications Thermiques de l'Energie Solaire dans de Domaine de la Recherche et de l'Industrie, Montlouis, June 23-28, 1958, pp 87-128, CNRS, Paris, 1961.
6. M. Sadat, Bouzareah Laboratory, Algiers, October 17, 1977, private communication.
7. T. Sakurai, "Study on the Solar Furnace Instrumentation in Tohoku University," Proceedings NSF International Seminar on Large Scale Solar Energy Test Facilities, New Mexico State University, Las Cruces, New Mexico, November 18-19, 1974, pp 67-97.
8. F. Trombe and C. Royere, "CNRS 1000 kW Solar Furnace" Proceedings NSF International Seminar on Large Scale Solar Energy Test Facilities, New Mexico State University, Las Cruces, New Mexico, November 18-19, 1974, 137-186.
9. R.-M. Meunier, "Caractéristiques et Objectifs des Fours Solaires du Laboratoire Central de l'Armement" Rev. Int. Htes Tempér, et Réfract. 1973, t. 10, pp 297-302.
10. G. Francia, "University of Genoa Solar Furnace," Proceedings NSF International Seminar on Large Scale Solar Energy Test Facilities, New Mexico State University, Las Cruces, New Mexico, November 18-19, 1974, pp 99-136.
11. J. D. Walton, C. T. Brown, S. H. Bomar and N. E. Poulos, "Preliminary Results from the Georgia Tech 400 kWth Solar Thermal Test Facility," presented at the ISES International Solar Energy Congress, New Delhi, India, 16-21 January 1978.

12. A. Uenishi, Hitachi Research Laboratory, March 30, 1977, Private communication.
13. N. Nakamura, "Solar Energy Collecting Test Apparatus," In-house paper of Mitsubishi Heavy Industries, Ltd., 1976-1977.
14. N. Nakamura, "A Study on Solar Tower Power Plant," In-house paper of Mitsubishi Heavy Industries, Ltd., March 1977.
15. J.-L. Perrier, "Capteur Solaire à Concentration," Revue Internationale d'Helio-technique, 2, 1977, pp 54-55.
16. T. R. Tracey, F. A. Blake, C. Royere and C. T. Brown, "One MWth Solar Cavity Steam Generator Solar Test Program," Proceedings of the 1977 Annual Meeting American Section of The International Solar Energy Society, Orlando, Florida, June 6-10, 1977, Volume I, pp 21-15 through 21-20.
17. "France Feeds a Utility," Business Week, McGraw-Hill, October 11, 1976, pp 29-30.
18. B. D'Utruy, D. Blay, Coeytaux, "The French C.N.R.S. One Megawatt Solar Power Plant," Extended Abstracts, Vol. 3, ISEC 77 International Solar Energy Congress, New Delhi, India, 16-21 January 1978, pp 1338-1340.
19. Programme Interdisciplinaire de Recherche pour le Developpement de l'Energie Solaire, P.I.R.D.E.S., Rapport d'Activite, Juillet 1975 - Aut 1976, CNRS and Activités en Cours Au 1 Juillet, 1977, CNRS.
20. H. F. Budd, "Survey of Solar Thermodynamic Energy Conversion," CNRS, 972 5th Avenue, New York, 1977, pp 7-13.
21. M. Rodot, "The CNRS Interdisciplinary Research Program for Solar Energy Development," CNRS Research, No. 6, 1977, pp 8-14.
22. B. F. Authier, "Design of a Stationary Spherical Collector," Extended Abstracts, Volume 2, ISES 77 International Solar Energy Congress, New Delhi, India, 16-21 January 1978, pp 1034-1036.
23. J. L. Boy Marcott, "Thermosolar Plant with Linear Focusing," Extended Abstracts, Volume 3, ISES 77 International Solar Energy Congress, New Delhi, India, 16-21 January 1978, pp 1351-1352.
24. T. Noguchi, "Project Sunshine," Proceedings NSF International Seminar on Large Scale Solar Energy Test Facilities, New Mexico State University, Las Cruces, New Mexico, November 18-19, 1974, pp 187-216.
25. F. de Winter and J. W. de Winter, "Description of the Solar Energy R&D Programs in Many Nations," Final Report, ERDA, Contract E(04-3)-1122, Altas Corp, Santa Clara, California, February 1976, pp 261-270.

26. H. Gehrke, "10 kW Solar Power Plant," Extended Abstracts, Volume 3, ISEC 77 International Solar Energy Congress, New Delhi, India, 16-21 January 1978, pp 1324-1327.
27. J. Feustl and M. Simon, "Exploitation of Solar Energy via Modular Power Plants and Multiple Utilization of Waste Heat," Extended Abstracts, Volume 3, ISEC 77 International Solar Energy Congress, New Delhi, India, 16-21 January 1978, pp 1305-1308.
28. H. Kleinwachter, "Parabolic-Mirror Solar Concentrator (PSK) with Cavity Light-Trap and Synchronous Motor-Drive of the Sidereal Axis," KLERA, 7850 Lorrach (Baden) West Germany, in house publication, 1977.
29. F. de Winter and J. W. de Winter, "Description of the Solar Energy R&D Programs in Many Nations," Final Report, ERDA Contract E(04-3)-1122, Altas Corp, Santa Clara, California, February 1976, pp 165-172.
30. Coopération Méditerranéenne Pour l'Energie Solaire (COMPLES), Bulletin de Liaison, No. 30, Janvier 1978, pp 29-34.
31. Roberto Visentine, Università Degli Studi della Calabria, Cosenza, Italy, April 22, Rome, Italy, Private communication.
32. H. F. Budd, "Survey of Solar Thermodynamic Energy Conversion," CNRS, 972 5th Avenue, New York, 1977, p 42.
33. C. S. Selvage, DFVLR, Cologne, West Germany, May 17, 1978, Private communication.
34. Coopération Méditerranéenne Pour l'Energie Solaire (COMPLES), Bulletin de Liaison, No. 30, Janvier 1978, pp 29-34.
35. J. D. Walton, Jr., A. H. Roy and S. H. Bomar, Jr., "A State of the Art Survey of Solar Powered Irrigation Pumps, Solar Cookers and Wood Burning Stoves for Use in Sub-Sahara Africa," Final Report for AI Dir'Iyyah Institute of Geneva Switzerland, Georgia Institute of Technology, January 1978.
36. H. F. Budd, "Survey of Solar Thermodynamic Energy Conversion," CNRS, 972 5th Avenue, New York, 1977, p 49.
37. R. Almanza, A. Diaz, A. Gonzalez and S. Lopez, "1 kW Solar Pump System," Proceedings of the ERDA Conference on Concentrating Collectors, Georgia Institute of Technology, 1977, pp 8-47 through 8-53.
38. I. H. Sakr, Director Solar Energy Laboratory, NRC, Dokki, Cairo, October 25, 1977, Private communication.

THIS PAGE INTENTIONALLY LEFT BLANK

SECTION II

WORKING GROUP SUMMARIES

ABSORBER SURFACES AND REFLECTIVE MATERIALS

Session 1, Group 1

Pat Call and Keith Masterson, Leaders

Solar Energy Research Institute
Golden, Colorado 80401

Recognizing the diversity of subject areas to be discussed in this working group, two sections were formed. Sections A & B addressed the Absorber Surfaces and Reflective Materials respectively. The discussion summaries are presented below for each section.

SECTION A: ABSORBER SURFACES

Introduction

The working group on Absorber Surfaces discussed three issues listed below and the results are summarized in the following report:

- 1) commercial absorber surfaces for concentrating collectors;
- 2) degradation mechanisms of Black Chrome;
- 3) durability and lifetime testing for absorber surfaces.

Commercial Absorber Surfaces

The demonstrated temperature stability of commercial absorber surfaces for concentrating solar collector applications is described in Table 1. The most experience has been obtained with Black Chrome. Sandia, Al. has recently produced Black Chrome films under laboratory conditions with improved temperature stability. A technical note has been submitted to Plating and Surface Finishing which describes the experiments in detail.

The status of R&D absorber coatings, including the work currently funded as part of the Advanced Solar Thermal Technology Absorber Surface Program (Table 2), was reviewed. Work on CuO/Ag (SIU/U of Illinois Urbana-Champaign), cermet development (MIT Lincoln-Labs, University of Sidney), and molybdenum films from molten salt deposition (Climax) was described.

Degradation of Black Chrome

Changes in film morphology and film chemistry were posed as mechanisms for decreased solar absorptance at operating temperatures greater than 300°C. A model for Black Chrome describing the film as an agglomeration of Cr and CrO_x particles leads to the proposed thermal degradation mechanism of redistribution of the oxide content (U. of Houston). Studies using SEM and TEM have indicated that a change in particle size may also be involved (LBL).

Work contracted by SERI at Clarkson College will study the degradation mechanisms of Black Chrome utilizing a microgravimetric balance in liaison with optical and surface characterization.

Durability and Lifetime Testing

The factors influencing the durability and useful lifetime of absorber surfaces are listed in Table 3. The discussion of the working group concentrated on the first three issues listed there.

Durability testing can be used to compare coatings or to predict the lifetime of a given coating on the basis of a short term experiment. Knowledge of the degradation mechanisms of a coating is essential for the construction of a meaningful accelerated lifetime test. No coatings currently are well enough characterized to design such tests and therefore the discussion was directed toward comparative testing.

Comparative testing consists of two types:

- 1) Prescreening tests at the research level, and
- 2) standardized functional tests based on end use.

The prescreening tests should be conducted by the experimenter or integrated as part of a larger program of evaluation and must be flexible enough to fit the coating or intended application. The standardized functional tests must be designed to allow the user of an absorber coating to compare coatings for an application. Such a test may be used by the producer or the user, measuring the time to failure (predetermined criteria) of optical properties or adhesion. A strong recommendation of the working group was that such functional tests be constructed using synergistic environments, i.e. high temperature, solar radiation, and moisture must be applied in combination rather than in isolation.

Two classes of environments appear adequate to describe the linear focus concentrating systems: the vacuum environment and the humidity environment. A proposed functional test which emerged from the discussion for each of these environments is described in Table 4. The operating temperature (T) can be assumed to be 300°C for the vacuum and 200°C for the humidity environment. The temperature difference, ΔT , which represents the safety margin, is assumed to be 100°C. It was pointed out that in the case of the loss of power to a system, the ΔT margin is not intended to simulate long term stagnation. Stagnation temperatures of many concentrating collectors are high enough to destroy current commercial selective absorber surfaces. E-W tracking single axis collectors are protected from overheating conditions more than the N-S single axis tracking collectors. The thermal cycling for the humidity environment simulates freezing and thawing. Solar irradiation of X10 and humidity equivalent to 90% at 100°F were proposed as standard values. The need for a standardized irradiation spectrum was emphasized.

TABLE 1

COMMERCIAL ABSORBER SURFACES

<u>COATING</u>	<u>DEVELOPER/SUPPLIER</u>	<u>T. STABILITY (°C)</u>	<u>TEST</u>
BLACK CHROME	(MANY)	285	FIELD
	SANDIA-ALB.	400(?)	LAB
INTERFERENCE } FILMS } (VACUUM)	OCLI	>400(?)	LAB
	GE		
	OWENS-ILLINOIS		
NI FOIL	ERGENICS	<400	LAB

TABLE 11

CURRENT ABSORBER SURFACES CONTRACTS

1. SELECTIVE ABSORBERS FOR APPLICATIONS $> 300^{\circ} \text{C}$.

- CVD SEMI-CONDUCTOR/METAL STACKS (U. OF ARIZONA)
- METALLO-ORGANIC SOLUTIONS (ENGELHARD INDUSTRIES)
- AMORPHOUS SILICON-COMPLETED (ARGONNE NATIONAL LABORATORY)
- GRANULAR SEMI-CONDUCTORS (RCA LABORATORIES)
- DISPERSED METAL PARTICLES (CORNELL UNIVERSITY)

ACCOMPLISHMENTS

- STABLE COATINGS AT TEMPERATURES $> 500^{\circ} \text{C}$. DEVELOPED WHICH HAVE $\alpha_s = 0.94$, $\epsilon_T = 0.16$ (Ni/Al₂O₃ CERMET)
- Ag/CuO/Rh₂O₃ METALLO-ORGANIC WITH $\alpha_s = 0.91$ AND $\epsilon_T = 0.06$

Current Absorber Surfaces Contracts

II. High Temperature Coatings

- Optical Properties of Alloys-Completed (U. of Arizona)
- High Temperature Paints (Exxon)

Accomplishments

- High Temperature Alloys with α_s between .8 and .9 Were Identified
- Seven Inorganic Pigments Have Been Identified Which Have α_s between .95 and .98 (not selective) and Appear Stable at 700° C.

Current Absorber Surfaces Contracts

III. Basic Mechanisms

- Morphologies of Absorber Surfaces (U. of Houston)
- Optical Properties of Metals, Metal Particles and Composites (Cornell)
- Composition Profiling of Solar Coatings (U. of Minnesota)

Accomplishments

- Black Chrome Microstructure Characterized
- Mean Field Continuum Model Developed
- Advanced Coatings Have Been Analyzed for ANL, U. of Arizona, etc.

TABLE III
FACTORS INFLUENCING DURABILITY OF COATINGS

1. Solar Radiation	4. Atmospheric Contaminants
Total Solar Spectrum UV Band	Oxygen NO _x Ozone SO _x
2. Temperature	5. Dust
Normal Operation No-flow Conditions Cycling	6. Contamination from other system components HCl, Cl ₂ from gaskets and glazings
3. Water	7. System Compatibility
Humidity Condensation Rainfall	Thermal expansion Outgassing

TABLE IV

VACUUM ENVIRONMENT

- a. Solar radiation (x10) + high temperature ($T + \Delta T = 400^{\circ}\text{C}$)
- b. Thermal cycling (-20°C to $T + \Delta T = 400^{\circ}\text{C}$, 2 hr period)

HUMIDITY ENVIRONMENT

- a. Solar radiation (x10) + humidity (90% RH at 100°F) + high temperature ($T + \Delta T = 300^{\circ}\text{C}$)
- b. Thermal cycling (-20°C to $T + \Delta T = 300^{\circ}\text{C}$, 2 hr period)

SECTION B: REFLECTIVE MATERIALS

Two general areas of concern were addressed, namely reflector specularity and life testing/degradation. The following reports the discussion in each area.

Reflector Specularity

The use of a bidirectional reflectance distribution function is too complex for most users and too expensive to implement for the majority of the industrial community.

The reflectance functions defined by R.B. Pettit (SAND 76 0537) and B.L. Butler and R.B. Pettit (SPIE Vol. 114, Optics Applied To Solar Energy, 1977) defines the surface's optical properties by a sum of normal distributions having standard deviations that characterize the amount of scattering from the surface and integrated areas equal to the directional-hemispherical reflectance. In practice one or two terms are all that are required for characterization. Some participants from industry indicated that these measurements requirements were also too demanding and expensive to implement at their level.

At the industrial level, a simple instrument that would be adopted as a standard and provide a reflectance distribution was suggested. Some discussion as to the appropriateness of this approach revealed that the meaningful data is contained in the wings of the reflectance profile and hence is extremely sensitive to instrument parameters. Use of such an instrument in an industrial environment may not yield reliable results.

Sample curvature is extremely difficult to separate from surface scattering effects in the reflectance distribution. Probably the only suitable way of performing this separation is by using

techniques of Fourier Transform optics. This should be explored more fully.

The instrumentation that was desired by collector manufacturers should be inexpensive and simple to operate. The increasing use and declining price of microprocessors would seem to justify their inclusion into the measuring equipment. They could remove some of the operator and data handling errors associated with the characterization. It was recommended that DOE fund the initial development of such an instrument through one of the laboratories and that production be licensed to industry. The effect of wavelength on the scattering function is quite well known and so a monochromatic device would probably be adequate, especially if adopted as a standard.

Life Testing/Degradation

Less time was spent on this topic. Nevertheless, several mechanisms for degradation were identified. Thermal cycling and stresses associated with different coefficients of thermal expansion were identified with a large number of concentrator failures.

Effects of moisture, especially coupled with marine salt or alkaline dust, was identified as causing rapid degradation in surface optical properties.

Tests to characterize durability should also include the effects of spillage of heat transfer fluid on the optical surfaces. Also important is the effect of galvanic corrosion that may take place due to the interaction of the reflector material and the mounting structure. Hence, lifetime or weatherometer tests should be carried out with reflector materials in sample mountings.

There was limited confidence by the participants that results of accelerated testing could be used to adequately predict field life.

Degradation rates determined in carefully controlled experiments that fix all but one environmental parameter may change considerably under synergistic effects of simultaneous exposure to several degrading environments. Some mechanism may involve failure thresholds that accelerated testing exceeds.

Rates accelerated by a factor greater than 2 or 4 become suspect for long-term prediction.

Some of the present testing such as thermal cycling between -29°C and $+52^{\circ}\text{C}$ with 8 hr cycles was criticized as being too severe.

WORKING GROUP ATTENDEES

Session 1 - Group 1

Section A

<u>Name</u>	<u>Affiliation</u>
Hugh C. Barnes	Reynolds Metal Co.
Calvin C. Beatty	Berry Solar Products
Albert C. Benning	Harshaw Chemical Co.
John D. Garrison	San Diego State University
John C. Kiminas	Olympic Solar Plating
Donald J. Levy	Lockheed Research Laboratory
Don Mattox	Sandia Laboratories
Matt McCargo	Lockheed Research Laboratory
Albert F. Naccach	ATON Solar Manufacturing
M. Resner	Department of Energy
Aharon S. Roy	Oak Ridge National Laboratory
Daniel V. Sallis	Custom Engineering
R. R. Sowell	Sandia Laboratories
Alfred J. Thelen	Optical Coatings Laboratory, Inc.
R. Viswanathan	Hughes Aircraft Company

WORKING GROUP ATTENDEES

Session 1 - Group 1

Section B

<u>Name</u>	<u>Affiliation</u>
Miriam Beesing	Honeywell, Inc.
Joseph Bezborodko	Mechanical Mirror Works, Inc.
Arnold F. Clark	Lawrence Livermore Laboratories
William D. K. Clark	International Nickel Company
Kirk Collier	LASL
G. R. Cunnington	Lockheed Palo Alto Research Laboratories
C. R. Frownfelter	PPG Industries, Inc.
Gus Hutchison	Solar Kinetics, Inc.
I. Earl Lewis	Ford Aerospace
Michael A. Lind	Battelle Northwest
M. G. Motnyk	Horizon Solar Corporation
R. D. Pottl	Gardner Mirror Corporation
John Powers	Alcoa
Kent M. Price	Stanford University
Roger E. Riggs	Thermal Dynamics, Incorporated
Aaron S. Roy	Oak Ridge National Laboratories
Bill Saylor	General Electric Company
Johanna Schruben	Westinghouse Research & Development
B. D. Shafer	Sandia Labs
A. F. Shoemaker	Corning Glass Works
Karl Sterne	Direct Energy Corporation
J. D. Walton	Georgia Technical Institute
Paul L. White	Owens-Illinois
Jeff Zimmerman	General Electric Company

MECHANICAL-STRUCTURAL ANALYSIS AND DESIGN CONSIDERATIONS

Session 1, Group 2

M. W. Frohardt, Leader

Martin Marietta Aerospace Division
Denver, Colorado 80201

Introduction

The agenda for the workshop was discussed and it was generally agreed to use the handout as a guide. Each attendee identified himself with a description of his interests in relation to the workshop. The objective set for this session was to determine the technological barriers that exist and to identify areas needing basic and applied research. The session limited its considerations to concentrating collector technology applicable to solar heating and cooling, process heat, electrical generation and photovoltaics.

Review of Concentrating Collector Technology

In addition to the concentrating collector technology discussed in the invited papers during the symposium, several other programs and technologies were presented to this working group:

1. The Mississippi County Community College design uses a set of flat plates covered with a fresnel reflector strip (3M Co.) of about 100 Mils thickness to simulate a parabolic trough. At the line focus, approximately 288 photovoltaic cell panels produce a peak output of about 1 KW_e . The one-axis tracking, one-axis orientation

produces a 20/1 concentration ratio. Active cooling is provided using a water/glycol mixture. The photocell cost is approximately \$3.50 per peak watt, with a cell efficiency between 12.5% and 14%, at an operating temperature of 55°C.

2. A concentrating collector manufactured by SUN TRAC for photovoltaic application is presently undergoing testing by Sandia Laboratories. The cells require passive cooling and are presently operating at about 14 1/2% efficiency. The design incorporates a matrix of cone-shaped collectors with the cells at the base, below a thin diffuser plate. To date, nineteen units have been manufactured, with a present system cost of \$10 per watt. The most expensive part of the enclosed unit is the cover bubble. A realistic bubble life is considered to be about three to five years.

3. Other Types of Collectors

The possibility of reviving a concept first developed in 1913 where the parabolic trough rests on a flat surface and is moved by an attached pivot arm was discussed. The receiver is a basic cone shape. In 1960 Boeing revived the idea using an inflated cover to protect the mirror surface.

A wagonwheel design where the trough collector can be rotated on support rollers to provide single-axis tracking, thereby eliminating the need for flex hoses or slip joints, was discussed.

Rolling type structures were considered but it was decided that they are too expensive and therefore not competitive.

Technology Problems

A group discussion brought out the problem areas listed below:

1. Problem of using inflatable covers with high-temperature systems (<1700°F). Presently environmental degradation of dome is not a problem. The problem of wind loads vs sandblasting damage to dome in terms of required stiffness was mentioned.
2. Collector design problems were described in terms of microwave antenna technology, notably the use of elliptical shaping for receiver struts to minimize shading.
3. The gusting problem was discussed in terms of its effect on windmill design, notably the need to consider complete reversal of flow conditions.
4. There may be an over-design in many collector subsystems i.e., too many safety margins applied at too many levels of design review.
5. It was mentioned that A&E firms estimate that over-design results in about a 15% increase in total cost. Vortex shedding could be a problem, and there is a need to consider edge effect versus middle-of-field effect in designing collector supports. Hail design alternatives i.e., whether to design collectors to withstand 3/4 - inch

diameter hailstones, or to go to a stow position (like European designs) were discussed.

6. Statement was made that it would be possible to reduce costs by providing site-specific designs i.e., natural wind barriers and site environmental data.
7. A question was asked about the effect of hailstone "dimpling" on collector performance. It was stated that the flux distribution resulting from "dimpling" is not known.
8. The problem of designing to withstand multiple load conditions was addressed with emphasis on specifying a combined loading effect.
9. The problem of forming glass/mirror was discussed and related to sagged glass method. Air sag (free form) is used for semi-accurate production, like windshields. More precise techniques use a vacuum form with a male or female mandril, with preference for the male based on thermal stress considerations.
10. Concern was expressed that gaskets and seals may be a problem.
11. The need for caution in developing design standards so early that they may result in unnecessary costs was expressed.
12. The need to involve utilities and other user organizations in setting design requirements, and the possible development of a design practices handbook was discussed.

13. The need for a Collector Performance Simulation Workshop to address problems of normalizing or standardizing system performance was discussed.
14. The use of cheap (\$100/ton) ceramic materials for solar applications, as well as the investment requirement for manufacturing facilities was mentioned.

Summary of Major Problem Areas

The problems discussed were separated into two categories to identify those that the group considered major problems areas and those that were considered less urgent.

1. Major Problem Areas:

- a) Windloading

Gusting, vortex shedding, edge vs center field effect, windbreak utilization, pressure differential.

- b) Hail effects

Requirement for withstanding the hail impact in the stowed position rather than operating position.

- c) Curved collector fabrication methods

Sag glass method is not accurate enough.

d) Seals, gaskets and equipment design support.

e) Simulation workshop

Standardize performance and analysis codes.

f) Development of manufacturing facilities for mirrors, fresnel lens, ceramics and other materials used.

2. Secondary Areas:

a) Definition of environmental load combinations.

b) Standards development for spectral reflectivity, black coatings, environments and blockage.

c) Definition of user/utility interface.

d) Development of a design practices handbook and standard terminology.

WORKING GROUP ATTENDEES

Session 1 - Group 2

<u>Name</u>	<u>Affiliation</u>
Marc A. Adams	Jet Propulsion Laboratory
Walter J. Apley	Battelle Pacific Northwest Labs
Kirt W. Bailey	Colorado Technical College
Jerry O. Bradley	Desert Research Institute
George P. Branch	Hexcel Corporation
Harry J. Brax	W. R. Grace & Co., Cryovac Div.
Doug Danielson	Morse Div. Borg Warner
Edgar Drubin, Jr.	BDM Corporation
James Eibling	Battelle-Columbus
Melvin W. Frohardt	Martin Marietta Corporation
Peter B. Grytness	Mann-Russell Electronics, Inc.
Ray S. Horrall	Morse Chain Borg Warner
Stephen I. Kaplan	Oak Ridge National Lab
James A. Leonard	Sandia Laboratories
George Lymbouris	Economist
Roy W. Miller	American Science & Engineering
W. D. Mitchell	Solaramics, Inc.
Luther E. Rhoades	ESSCO
Maxwell M. Small	Brookhaven National Laboratory
Dan Stolarczyk	Morse Brg Warner
Lloyd Wartes	Solar Energy Industries Association
John C. Yeoman	Oak Ridge National Laboratory
Peter P. Zemanick	Westinghouse Advanced Energy Systems

THIS PAGE INTENTIONALLY LEFT BLANK

MATERIALS - FLUID COMPATIBILITY

Session 1, Group 3

Steven Pohlman, Leader

Solar Energy Research Institute
Golden, Colorado 80401

Introduction

The main objective of the discussion group was to identify the major materials-fluid compatibility problems that exist in thermal power solar energy systems and to outline the problem areas that should be investigated to insure reliability of the various systems. The discussion was divided into the following areas:

- 1) Thermal conversion, including flat plate collectors, line focusing receiver systems, power tower (STTF) and advanced receiver designs.
- 2) Reflector durability, including protective coatings, sealants, and mirrored surface degradation.
- 3) Thermal storage systems, including sensible heat storage, latent and chemical heat storage.
- 4) Structural degradation.

The list of problems may not be complete, but does represent a fairly comprehensive overview of the compatibility problems expected in thermal conversion solar energy systems.

Thermal Conversion

1. General corrosion of flat plate collectors (Al, Cu, Fe) is a serious problem. Development of an inexpensive solution, including line monitoring systems, inhibitor evaluation, and inexpensive coatings development should be sought.
2. Localized attack of space heating systems are caused by a) heavy metal and Cl-contamination of the heat transfer fluid, b) presence of crevices and stagnant areas, and c) poor system evaluating and design considerations.
3. Environmental and mechanical interactions, including corrosion fatigue, stress corrosion cracking, temper embrittlement, sensitization, creep, and fretting fatigue, accelerated by the cyclic temperature nature of solar receivers in the presence of air, water, Na, NaK, molten salts and high temperature gases are important. (This also includes chemical changes caused by the cyclic ΔT leading to potential grain boundary cracking or localized attack of the heat exchanger materials.)
4. Cyclic breakdown of protective films, natural as well as man-made, are caused by interaction with the environment and large cyclic ΔT . This includes advanced receiver fluids (e.g. Na, NaK, etc.). Their effect on the internal walls depletion of elements and plating out on cooled surfaces was mentioned.
5. Protective schemes for high temperature and/or high pressure power generating systems are needed. Evaluation of inhibitors and development of new ones, monitoring systems, directed research on pilot plants,

pulsating cathodic/anodic protection, water chemistry control, and any combination of the above should be pursued.

6. General corrosion attack of high temperature and/or pressure systems, involving various heat transfer fluids (i.e., water, Na, molten salt, gas, air) and their general effect on the various forms of corrosion (i.e. galvanic, crevice, erosion, wastage, H₂ embrittlement, SCC, mass transfer, intergranular attack, caustic cracking) was discussed.
7. Chemical contamination or degradation of heat transfer fluids is caused by the environment and its effect on the container materials (e.g. creation of organic acid caused by breakdown of synthetic oil) can be serious.
8. An evaluation of start-up/shut-down procedures and their applications to solar energy systems, including cleaning procedures, possible residue effects, O₂ ingress and changes in water chemistry, should be undertaken.
9. Stability of the heat transfer fluid is an important research topic. This includes the development of inexpensive high temperature synthetic fluids that resist degradation and will maintain their heat transfer properties.

Reflector Durability

1. Compatibility of the protective outside coating (glass and organic polymers) with respect to leaching by natural environments (alkali dust plus water), cleaning solutions or contaminants from leakage in the receiver

tubes should be studied. Possible degradation of glass coatings occur by an ion exchange mechanism with the above solutions. Abrasion and corrosion/erosion resistance, mechanical stability and permeation resistance to aggressive fluids or vapors, resistance to U.V. degradation, and compliance of optical properties are important.

2. General heliostat corrosion caused by non-protective edge seals, adhesive outgassing, crevice concentrations, wind/sand erosion, and freezing/thawing cycles of sealed areas, and delamination caused by corrosion product wedging can cause problems.
3. Chemical resistance of the mirrored surface needs to be improved by alloying or protective techniques.

Thermal Storage

The following topics deserve attention:

1. Sensible heat storage - heat fluid interaction with storage mass (e.g. rocks) and its interaction with the container materials (250-900°C) - general corrosion problems.
2. Latent heat storage-material compatibility (molten salts, fluorides, chlorides, carbonates) with container material (800-1200°C) - general corrosion problems.
3. Reversible chemical reactions - high temperature metal/gas reactions and possible formation of acidified solutions such as H_2SO_4 .

Structural Degradation

The following are potential problems:

1. General corrosion of structural members.
2. Reliability of seals.
3. General protection of mechanical and electrical components.

Conclusion

1. It was the general concern of the attendees that not enough information is being generated to solve the unique problems that exist in solar energy power systems. It was felt that a concentrated effort should be made to gather pertinent information from existing technology and then supplement this existing technology with new research that would take into account the unique parameters experienced in solar energy systems (e.g. cyclic ΔT).
2. Standards are required that can describe solar energy material requirements.
3. Evaluation and correlation of accelerated testing is needed.
4. Determination of critical parameters unique to solar energy systems and their impact on service and reliability is necessary.

5. An organization such as SERI needs to take the lead role in developing a uniform reporting technique that should then be used by all laboratories and provide an information retrieval system unique to solar.

WORKING GROUP ATTENDEES

Session 1 - Group 3

<u>Name</u>	<u>Affiliation</u>
L. Davis Clements	Texas Tech University
William R. L. Thomas	Exxon Research and Engineering
Robert W. Jones	Hughes Aircraft Co.
L. G. "Ray" Rainhart	Sandia Labs
William E. Rogers	Rensselaer Polytechnic Institute
Barry D. Symmonds	NPD Energy Systems
Albert F. Naccach	ATON Solar Mfg.
Steven Pohlman	Solar Energy Research Institute

THIS PAGE INTENTIONALLY LEFT BLANK

PERFORMANCE STANDARDS DEVELOPMENT FOR CONCENTRATING COLLECTORS

Session 1, Group 4

Byard D. Wood, Leader

Mechanical Engineering Department

Arizona State University

Tempe, Arizona 85281

Introduction

A standard exists when an agreement has been obtained on its content. The level of agreement ranges from a small group of interested parties to national or international standards which have been developed through the consensus process. An excellent overview of a standard is presented by the National Bureau of Standards in Ref. 1. This publication summarizes the types of standards, the development of standards, the building regulatory process, solar standards development, solar standard implementation, and further recommendations for standard development and implementation. While this publication was prepared for solar heating and cooling applications, it has general applicability to all solar applications.

The purpose of this workshop was to determine the status of performance standards that have been developed or which should be developed for concentrating collectors. It is recognized that there is a distinction between testing to characterize the performance of the collector as opposed to testing for rating or certifying the performance of a collector relative to another collector. Also there are durability and reliability standards which relate to the long term effects on the performance of

collectors. This workshop dealt only with the performance standards for determining the thermal and/or electrical* performance of a concentrating collector.

The workshop discussions included many aspects of testing concentrators, but emphasized the following:

1. Environmental sensitivity of the collector module to ambient temperature, wind speed and direction, tilt angle and the amount of diffuse solar irradiation.
2. The temperature range of a particular collector absorber design.
3. The minimum solar irradiation level allowed for a given test.
4. The reporting format for the test data.
5. Tracking errors and concentrator slope errors.
6. Concentrator optics.
7. Absorber optics.
8. Reference test conditions, i.e., minimum insolation, maximum amount of diffuse radiation, a maximum temperature for test, etc.

* Even though the conference emphasized thermal collectors there was sufficient interest in photovoltaic collectors that the discussions included aspects appropriate to both.

9. Classification of concentrators: non-tracking, linear focus, point focus, and central receiver.

Previous Workshops on Concentrating Collectors

In September 1977, ERDA (DOE) sponsored a conference on concentrating solar collectors (2). This conference included a workshop on testing and standards conducted by Dr. James E. Hill of the National Bureau of Standards. Several recommendations came from this workshop.

1. DOE should publish information on (a) who is or has tested concentrating collectors, (b) what facilities exist for such tests, and (c) what test procedures are currently being used.
2. DOE should organize a formal working group consisting of those who are actually involved with testing concentrating collectors. The group should be expected to develop specific recommendations for the adoption of a standard thermal test method for concentrators. Specific technical areas to be addressed by this working group are: (a) how to handle multi-directional effects of incidence angle modifier, (b) how to handle the way in which concentrator efficiency varies with change in the percentage of diffused or scattered radiation, (c) the correct way to measure the incidence solar radiation onto a concentrator, (d) determine the applicability of ASHRAE Standard 93-77, and (e) should separate tests be required to measure the optical properties of the reflector and absorber.

Arizona State University hosted a photovoltaic concentrator systems workshop May 24-26, 1977 (3). This workshop, sponsored by DOE through Sandia Laboratories, included a workshop on array and component testing for photovoltaic concentrator systems. The emphasis of the discussions was on identification of the availability and the inadequacy of test measurement standards, test equipment and instrumentation and test results. The topic which received the most attention at this workshop was solar cell performance testing. The discussions centered on the availability and adequacy of cell measurements, standards and definitions. The overall conclusion of the testing working group was that a great deal needs to be done in the area of test standards and procedures generation. This is true for both performance and environmental testing at all hardware levels. It was recommended that an organization be assigned the responsibility and granted the funding to start work immediately on developing test standards and procedures.

Existing Standards For Testing Solar Collectors

The American Society of Heating, Refrigerating and Air-Conditioning Engineers has published ASHRAE Standard 93-77 which is a consensus standard for determining the thermal performance of solar collectors. It is primarily for collectors which are designed for use in solar heating and cooling systems for buildings. While ASHRAE 93-77 clearly states that it is applicable for concentrating as well as flat plate collectors, it should be noted that the technical data base for developing the standard was primarily performance data for flat plate collectors. Very little concentrator performance test data were available at

the time ASHRAE 93-77 was developed. This performance standard includes three tests:

1. Collector time constant test. The time constant of the collector is important in determining the time rate of response of the collector to a change in either environmental or thermal input conditions. Also, the length of the thermal performance test is dictated by the time constant.
2. Near normal incidence instantaneous efficiency test. The collector is maintained at quasi-steady state conditions at near normal solar irradiation for at least 5 minutes or one time constant, whichever is greater. The test data are then used to plot the measured efficiency vs. a parameter which is the difference between the collector inlet temperature and ambient temperature divided by the total solar irradiation as shown in Fig. 1. This curve characterizes the collector in terms of its near normal incident optics and its heat loss characteristics (4). An additional test is needed to determine what happens when the collector is operated at solar irradiation incident angles other than near normal.
3. Incident angle modifier test. Instantaneous efficiency tests are conducted for the collector such that the inlet fluid temperature is approximately equal to ambient, thereby holding the heat loss term to a minimum and measuring the thermal performance for several incident angles which can then be used in conjunction with the near normal incidence test to calculate an all day thermal performance of a given collector.

Several major problems have been identified for this performance standard. Collectors which do not have optical symmetry may have a multi-directional incident angle modifier. The test is based on the Hottel-Whillier-Bliss collector model (5), which assumes that the heat loss coefficient for the collector is independent of temperature. However, this is not the case and because of this the test results can have considerable scatter at the higher values of $(T_{fi} - T_a)/I_t$. The applicability of this standard to concentrating standards is not fully understood at this time, particularly in being able to predict all day performance based upon the instantaneous test in conjunction with the incident angle modifier test. Moreover, this standard does not address the problems of tracking error or slope errors associated with the concentrators, nor does it separate out the absorber characteristics from the concentrator characteristics.

Specific Points of Discussion

Participants in the workshop were invited to make brief presentations describing their concerns and their recommendations for a consensus standard for testing concentrating collectors.

Ari Rabl, SERI

1. Use net aperture area as the basis for all measurements and as a basis for cost estimates. It is easier to measure and define aperture area than it is to define or measure gross area because many collectors include mounting brackets and support arms in a way that it makes it difficult to define the gross area.
2. The concentration ratio should always be defined as the ratio of the aperture area to the receiver surface area.

The energy collected and the thermal losses should be reported in terms of watts/m² of aperture area.

3. Heat loss tests should be conducted at night. This gives a conservative design criteria since the measured heat loss coefficient at night will be somewhat greater than the heat loss coefficient during the daytime.
4. Direct beam radiation measured with a pyrheliometer should be used for concentration ratios greater than two and the total hemispherical solar irradiation measured with a pyranometer should be used for those concentrators which have a concentration ratio less than two. This approach minimizes scatter due to atmospheric haze which exists at many test facilities.
5. Optical efficiency tests should be made when the receiver surface temperature is equal to the ambient temperature and there are no heat losses from the absorber.
6. The average all day optical efficiency η_o , should be calculated from the following equation:

$$\eta_o = \frac{\int_{\text{clear day}} [q_{\text{out}}(t) + q_{\text{loss}}(t)] dt}{A \int_{\text{clear day}} I(t) dt}$$

7. The incident angle modifier or angular acceptance test indicates that the efficiency is a function of the east-west view angle and the north-south view angle. This information is thus needed for hourly simulation and for assessment of tracking and mirror errors. (Fig. 2)

William C. Thomas, Virginia Polytechnic Institute

1. Efficiency from a thermodynamics point of view is defined as the useful energy output from a device divided by the energy which we pay for. The solar irradiation is available for free--it is the collector we pay for. This implies that gross area is the appropriate term for expressing efficiency.
2. The performance of a concentrator can be expressed in terms of the near normal incidence efficiency as discussed in ASHRAE 93-77 and a bi-directional incident angle modifier using north-south and east-west view angles. This concept is illustrated in Fig. 3.
3. Tests conducted under clear sky irradiation conditions for which the diffuse radiation could consist primarily of forward scattering and test conducted under hazy conditions where the diffuse is more uniform, give an upper and lower limit of the collector performance as it relates to diffuse radiation.
4. Indoor testing can obviously lead to better control of the data, but some concern expressed that indoor testing with artificial sunlight often skews the spectral intensity distribution on the absorber. This is an adverse condition, particularly for photovoltaic absorbers.
5. A thirty day stagnation requirement is a real problem for concentrators.

William J. Putman, Desert Sunshine Exposure Tests, Inc.

1. DSET has conducted approximately 50 concentrator tests. The data are presented in terms of efficiency as a function of temperature with the direct insolation as a parameter. However, he suggested that efficiency be plotted as a function of the difference between the inlet fluid temperature and the ambient temperature divided by the direct beam radiation. This is the recommendation in ASHRAE 93-77.
2. For collectors used in the DOE demonstration program there is a specification for a 30 day stagnation test in order to establish durability and reliability measurements. However, for concentrating collectors this is a real problem since concentrators are not designed for stagnation exposure. Most concentrators will defocus at a preset absorber limit temperature.
3. The use of the incident angle modifier as specified in ASHRAE 93-77 should be used with considerable care for concentrating collectors.

M. E. Felix, Solaramics

Component testing should be developed as well as total system testing. There are many manufacturers who provide only a specific component of the collector module, i.e., concentrator or reflector/refractor, receiver, and tracking mechanism. He recommended that there should be testing procedures for evaluating the concentrator separate from the absorber and both of these separate from the particular tracker mechanism.

George Schrenk, University of Pennsylvania

Performance standards should be related to the application or end use anticipated for the particular collector module.

Concentrators should be classified in terms of the temperature limits, the amount of tracking required, the focus and non-focus characteristics, the concentration ratio and non-imaging characteristics of concentrating collectors. A given standard should specify the types of collectors for which it is appropriate.

Ronald Bracewell, Stanford University

The use of the aperture area and receiver area in specifying a concentration ratio is independent of the optical characteristics of a particular collector. He recommended the use of a flux concentration ratio which takes the reflectance and surface quality of a concentrator surface into account.

Art Ratzel, Sandia Laboratories

At the Sandia test facility, the major areas of concern were: (a) large uncertainties in small differential temperature measurements, (b) indoor heat loss tests not being related to outdoor heat losses that the collector experiences under test, (c) difficulty of getting quasi-steady state conditions for large arrays, and (d) uncertainties in the properties of heat transfer fluids at elevated temperatures, particularly ethylene glycol and Thermanol 66.

Jack Cherne, TRW Energy Systems

The ASTM standards committee E44 on solar energy conversion is being chaired by Gene Zerlaut, Desert Sunshine Exposure Tests, Inc. Anyone interested in participating in this standard committee should contact Mr. Cherne.

Jim Castle and Ari Rabl, SERI

The calorimetric technique for measuring $\dot{m}C_p$ for a given concentrating collector eliminates the large uncertainty in C_p (the specific heat). This concept is illustrated in Fig. 4.

None of the 8 participants who identified themselves as having actual test experience with concentrators made separate measurements on the tracking accuracy of the particular concentrator under test, i.e., concentrator tracked only as it was delivered from the manufacturer or client.

Acknowledgements

The author wishes to acknowledge the help of William C. Thomas and Frank Folino for their help in taking notes and reviewing the discussions for this writing.

Specific Recommendation by the Workshop Participants

There seemed to be a consensus concerning the major points that need to be addressed and solved for the development of test standards for concentrating collectors. They are:

1. Classification of concentrating collectors in terms of their application and unique design characteristics (end-use).

2. Uniform definitions for reflector, absorber, tracker, concentration ratio, slope errors, tracking errors, incident angle effect, etc.
3. Use two measurements for determining the concentration ratio: area ratio and flux ratio.
4. The calorimeter test procedure for determining $\dot{m}C_p$ should be further investigated to determine its accuracy relative to the techniques of measuring C_p and \dot{m} separately.
5. This is the third workshop with the same basic recommendations as the other two. It is urged that SERI take the lead to get the recommendations implemented, i.e., test labs should agree on how to report data, standard definitions should be developed, and the sensitivity of test results to test parameters should be determined.

References

1. Waksman, D., Pielert, J. A., Dikker, R. D. and Streed, E. R.; "Plan for the Development and Implementation of Standards for Solar Heating and Cooling Applications," NBSIR 76-1143, National Bureau of Standards, April 1976.
2. Solar Concentrating Collectors, Proceedings of the ERDA Conference on Concentrating Solar Collectors, Georgia Institute of Technology, Atlanta, GA, Sep 26-28, 1977, Tucker-Castleberry Printing, Inc., 226 Luckie St., NW, Atlanta, GA 30303.

3. Proceedings, DOE Photovoltaic Concentrator Systems Workshop, College of Engineering and Applied Sciences, Arizona State University, Tempe, AZ, May 24-26, 1977.
4. Sayigh, A.A.M., Solar Energy Engineering, Academic Press, 1977.
5. Duffie, J. A. and W. A. Beckman, Solar Energy Thermal Processes, John Wiley & Sons, 1974.

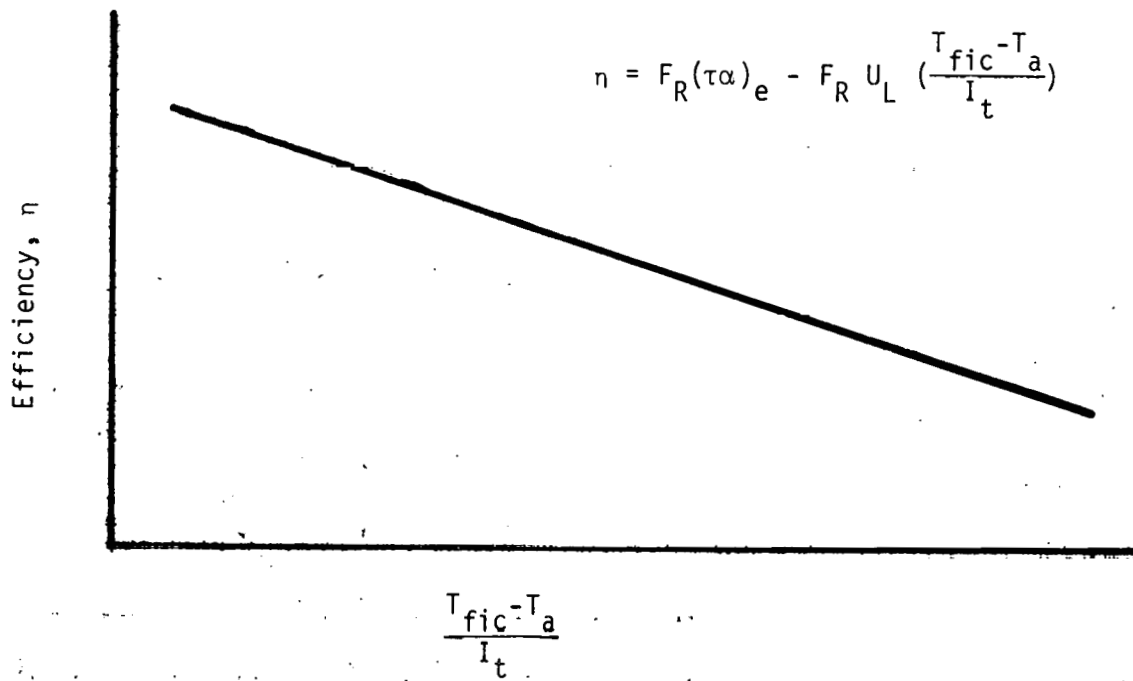

Fig. 1. Characteristic efficiency curve of those collectors which can be described by the Hottel-Whillier-Bliss equation.

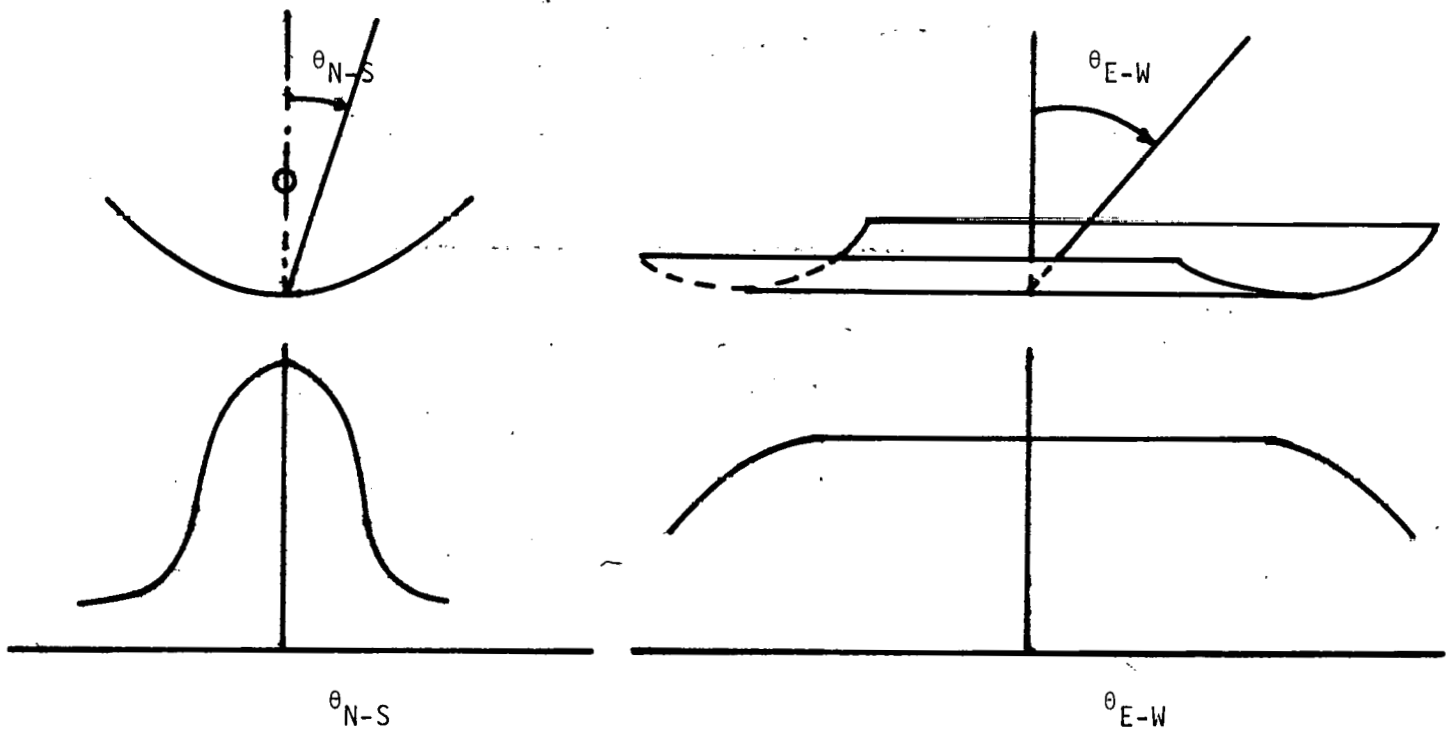

Fig. 2. The incident-angle-modifier for linear concentrators, whose major axis is oriented East-West, can be given in terms of the North-South view angle (tracking error) and the East-West view angle (reflector/refractor optics).

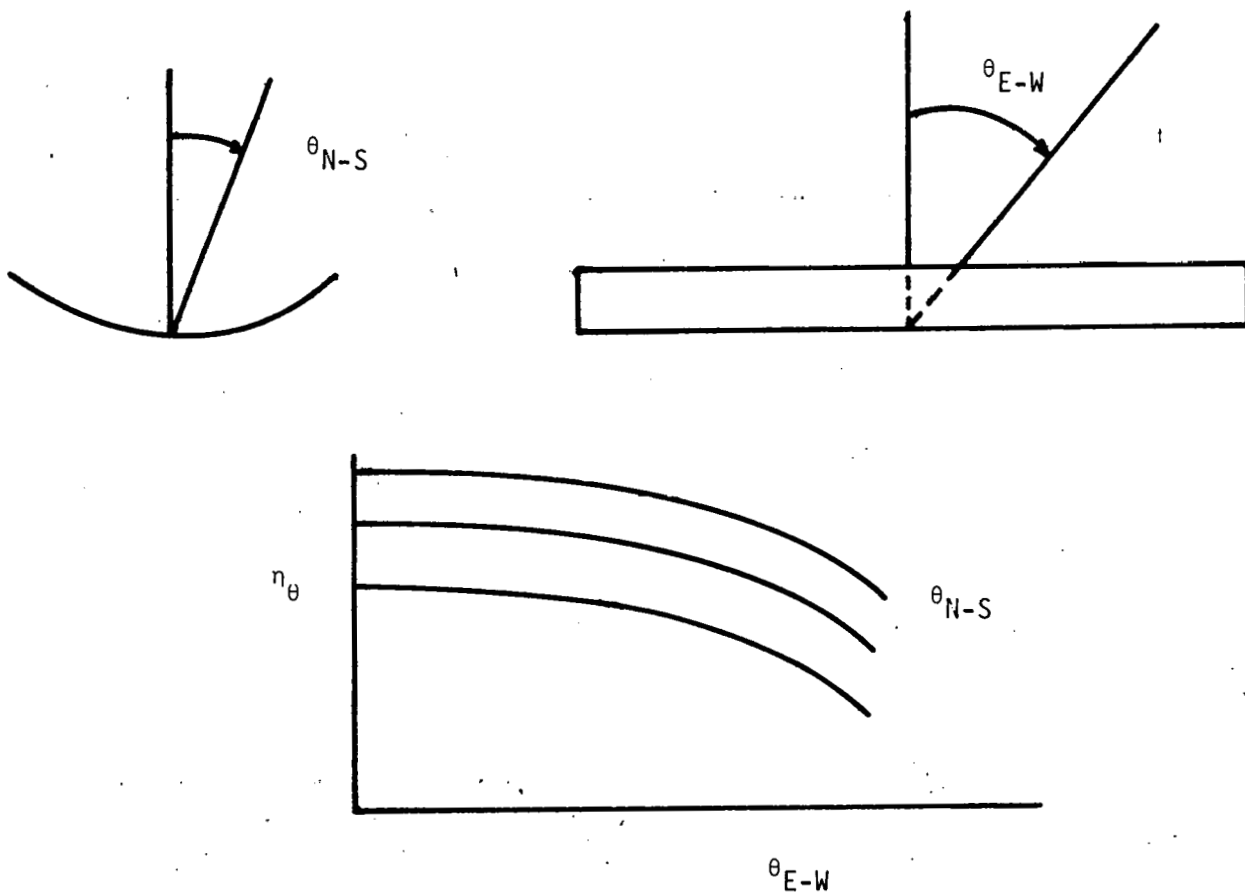
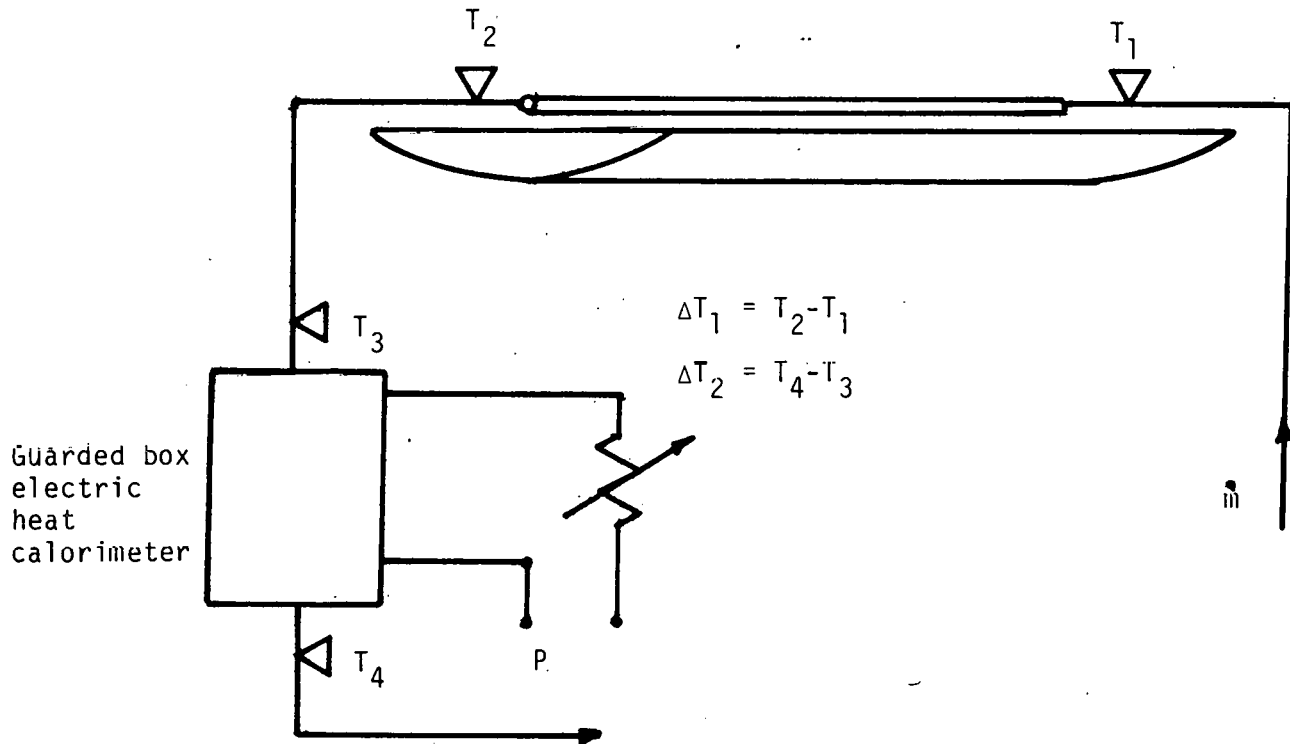

Fig. 3. For those collectors which have a bi-directional incident-angle-modifier, the off-normal efficiency can be described in terms of the East-West view angle, θ_{E-W} and the North-South view angle, θ_{N-S} .



For collector $Q_{\text{useful}} = \dot{m} C_p \Delta T_1$
 For calorimeter $Q = P = \dot{m} C_p \Delta T_2$
 Therefore: $Q_{\text{useful}} = (P/\Delta T_2) \Delta T_1$

Fig. 4. Illustration of the calorimetric technique for measuring $\dot{m} C_p$ insitu.

WORKING GROUP ATTENDEES

Session 1 - Group 4

<u>Name</u>	<u>Affiliation</u>
Ronald N. Bracewell	Stanford University
Lynn S. Brock	Harrison Radiator Div. GMC
Jim Castle	Solar Energy Research Institute
Jack M. Cherne	TRW Corporation
Jeffrey E. Christian	Oak Ridge National Lab
Terence B. Clark	Ford Aerospace & Communications Corp.
Milan H. Cobble	New Mexico State University
John R. Egger	Optical Sciences Group
Frank Faelino	MIT - Lincoln Laboratory
Dave Feasby	Solar Energy Research Institute
H. E. Felix	Solaramics, Inc.
Derrick P. Grimmer	Los Alamos Scientific Lab
E. Michael Henry	TEAM, Inc.
Brian Howard	Sun Heet, Inc.
Steve A. Ingham	Pikes Peak Solar Energy Association
David R. Johnston	Planning Research Corporation
Robert F. Mattson	EIA
William D. Miller	Martin Marietta Corporation
W. D. Mitchell	Solaramics, Inc.
William J. Putman	Desert Sunshine Exposure Tests, Inc.
Ari Rabl	Argonne National Lab
Arthur C. Ratzel	Sandia Labs
LaVerne W. Rees	Suntec Systems, Inc.
George L. Schrenk	University of Pennsylvania
Roger W. Taylor	Arizona Public Service Co.
William C. Thomas	Virginia Polytechnic Institute
L. Wen	Jet Propulsion Laboratory
Solomon Zwerdling	Northeast Solar Energy Center

THIS PAGE INTENTIONALLY LEFT BLANK

CONTROLS FOR CONCENTRATING COLLECTOR SYSTEMS

Session 1, Group 5

James Tobias, Leader

Honeywell, Inc.
Minneapolis, Minnesota

Introduction

The working group discussed:

1. tracking control;
2. drive control;
3. safety control; and
4. system controls.

A substantial amount of time was devoted to tracking control and the consensus seemed to be that this is the most prevalent problem facing concentrating solar collectors, but that systems control engineering was also sometimes lacking.

It was concluded that many problems can be avoided if the control engineer is brought to the job very early. If the controls and systems design work is done properly, 30% of the field problems can be eliminated.

Tracking Control

There were engineers from several collectors manufacturers in attendance and a lot of discussion centered on tracking. A key issue was whether the control should be open or closed loop.

An open loop control system uses a computer or clock mechanism to calculate the sun's position and then the motor, which may or may not have position feedback, drives the collector to that angular position. The problem with this type of system is mechanical compliance. The flexibility of the members and the backlash of the gear drive mechanism contribute to errors that usually are great enough to destroy the optimum receiving characteristics.

In a closed loop control system, a sun tracker views the sun and its feedback is used to position the solar collector so that the collector faces the sun. The normal accuracy of these types of systems is desired to be about 1/4 of an angular degree. If the controller could actually sense the insolation received at the collector as opposed to the usual separate sensor mechanism the best accuracy could be obtained. A practical implementation has not yet been achieved. One of the schemes that is being tried is based on measuring the temperature of the collector. Presently the technology is making use of photo cells or photo transistors to sense the sun and arranged with a shadow band to create the error signal for the drive system.

Conclusion: Closed loop control seem to be favored most heavily by the group.

Drive Control

The main concern is the selection of the motor. A small motor has to be geared, but produces a high accuracy in tracking. A large motor can move fast, but tends to overshoot quite severely. The best compromise is to build the drive mechanism either with pulse and modulation circuit or use a motor speed control that can slow a large motor to make it track accurately, but retains the advantage of the speed and torque of a large motor when needed in an emergency and for stowing the collectors in the evening.

DC motors are gaining momentum. Most people are using them because they are suitable for battery backup. They can be connected directly to the battery and the collectors can move to stow position even under a power loss. This is an advantage over AC motors because they have to be interfaced through an inverter or a motor-generator set to a battery. This added cost is easily offset by just using the DC motors. The consensus specifications for a drive mechanism is that motors have to drive at least 90 degrees per minute for fast stow; whereas for tracking they have to have a tracking accuracy of $1/4$ degree.

Safety Control

Safety control is a complex problem. Highly reliable parts are needed so that all the collectors can be defocused under any type of failure. Then the sun can't over-heat any of the collecting elements. If the collectors were left in the face up position, it is possible for the sun to move into a position where energy is focused onto the receiver. Individual temperature sensors are required on each collector. The surest way of maintaining reliability and high safety is to require manual reset after potentially serious types of failure. Over-temperature failures occur frequently during installation of the collector system. The

installation personnel often forget that the sun moves and if the sun moves into focus it can destroy the collector by generating excessively high pressure and temperatures.

Another critical area is the control of liquid level. First, there should always be enough liquid in the system to avoid collector burnouts. Secondly, the liquid pressure usually changes quite significantly because of the large temperature excursions. Therefore, to insure safe operating pressure in the systems, the pressure has to be maintained above a certain level so that the liquid will not flash or boil.

System Control

The group unanimously agreed that a lot of work has to be done in this area. System considerations seems to be the most often overlooked design activity and usually is done after the fact. System control should be integrated into system design. This would eliminate problems such as the collectors not providing the right amount of heat or electricity when it is needed. Therefore, the requirement for a control engineer to work early on the job to provide the system input and system design perspective to the problem is required. In addition, to test the advanced concepts of system control theory and design, a system test facility with load control features would be helpful.

Features offered by microprocessor are of advantage in insuring applications because they normally can be easily customized through changes in software. Most solar applications are special designs and therefore the control system has to be easily adaptable to each situation. The idea of applying a microprocessor with standard input/output hardware including actuators and yet having flexible functionality is a good one for potential cost savings.

The system engineer would appreciate a system that has instrumentation capability. Approximately 60 points of measurement including temperature, flow, and power are required. A comfort system that can offer control logic and instrumentation is a good consideration, but does not offer the reliability or flexibility of separate systems to do these specialized tasks. One of the problems of implementing a general purpose computer based controller is lack of configuration data. There are a number of installations being planned, designed and installed, yet there is no feedback defining the configurations and there are no standards and general purpose parts.

Suggested Action

The previous discussion led to the following conclusions.

1. Further optimization of the collector unit controllers is still required. A lot of work remains to be done in tuning and cost reduction of the collector control, drive, tracking and safety mechanisms. This work should be funded adequately to maintain the current momentum that already exists in developing these types of controls.
2. Develop a flexible controller that could meet the needs of various situations. This control could be based on a microprocessor and other general purpose standard hardware with specialized software for each particular installation. The software could be designed in modular fashion, similar to the hardware. Then, the controller could be customized for each application.

3. In support of the flexible system controller, a project should be started to define the configurations of the solar systems that are being installed and have been installed in the past. This input can be used to determine what control functions and sensors are really necessary, and to define the type of instrumentation that is required.
4. To insure that adequate system design is done on each new project, an environmental facility should be available and some design guidelines for solar collector field and its local controls should be established. These guidelines could be a checklist or a recommended design process that includes all the various considerations that go into the design. In other words, it's a step-by-step procedure definition for designing solar collector fields and systems.

Other Technological Problems

The first paragraphs summarized the various discussions of the symposium and workshop but some interesting quotations were missed. Following is a list of such items that might be interesting to the reader.

- The cost of a microprocessor or the logic for any system control is about one tenth (1/10) of the transducer or sensor costs.
- Modulating flow control is usually required if maintaining the temperature difference across the collector is necessary. But a large field requires many control valves. It was suggested that automatic flow balancers could alleviate this problem and reduce the number of flow control valves needed.

- There is a problem with oil in the 600°F range. It generates deposits and there is a requirement for oil scrubbers to keep the impurities out of the systems.
- Stagnation heat problems frequently occur during installation. The workmen leave the collector up, forgetting that the sun moves. Once in the right position to focus on the device, it will raise the temperature to the stagnation point. This temperature can immediately destroy collectors of some specific designs.
- The tracking and drive mechanism, and the sun seeking controls make up 15% of the cost of the collectors. This does not include the system control.
- Photovoltaic systems use fluids for cooling. When it is possible to use this fluid as process heat, the flow should be modulated to control certain temperatures to make it useful.
- There is a lack of system configuration data that is necessary to establish concentrating solar collector standards.
- There is a need for a set of design guidelines to ensure that control and system design are a part of the project plan.
- The instrumentation requirements should be specified early because sub-system manufacturers may more efficiently install sensors in the factory. Factory installed subsystem instrumentation can save on total system cost, but usually each subsystem is considered independently. This is a clear case illustrating why systems engineering is required for each new design.

THIS PAGE INTENTIONALLY LEFT BLANK

WORKING GROUP ATTENDEES

Session 1 - Group 5

<u>Name</u>	<u>Affiliation</u>
Graham H. Alexander	Battelle-Columbus Laboratories
Porter Arbogast	North American Sun, Inc.
M. M. Delgado	Jacobs-Del Solar Energy Systems, Inc.
Robert L. French	American Technological University
Howard J. Gerwin	Sandia Labs
George G. Goranson	DEL Manufacturing Co.
Louis C. P. Huang	Navy Civil Engineering Lab
Robert O. Hughes	Jet Propulsion Laboratory
H. R. Hull	Hexcel Corporation
Steve A. Ingham	Pikes Peak Solar Energy Association
Conrad Lanza	IBM Research Lab
John H. Laakso	Boeing Engineering & Construction
Stanley W. Moore	Los Alamos Scientific Lab
Edward L. Rossiter	ACUREX Corp! Alternate Energy Div.
Jack Ruff	Honeywell Energy Resources Center
George F. Russell	Mann-Russell Electronics, Inc.
Wayne Walters	Honeywell Energy Resources Center

THIS PAGE INTENTIONALLY LEFT BLANK

CLEANING AND MAINTENANCE

Session 2, Group 1

Roscoe L. Champion, Leader

Sandia Laboratories
Albuquerque, New Mexico

This working group decided that the purposes of the sessions should be to share experiences regarding cleaning of collectors, to identify problem areas, and to formulate recommendations for future efforts. At the beginning of the session the chairman presented an outline of important topics to be considered. These topics are:

- 1) Why is cleaning necessary;
- 2) What portions of a collector require cleaning;
- 3) What are the contaminants which accumulate;
- 4) What cleaning techniques have been tried, and which ones were successful;
- 5) How can the rate of dirt accumulation be slowed;
- 6) What frequency of cleaning may be necessary;
- 7) What is "clean" and how is it measured;
- 8) What are cost considerations and environmental limitations.

After a brief statement regarding the above stated purposes of the meeting and the desired output, the participants were invited to share their own experiences regarding the effects of dirt accumulation and the various cleaning techniques utilized. Detailed responses were encouraged to allow those who had actually cleaned collectors to share with others their successes and failures, their techniques, detergents, etc.

Although the second objective was to identify cleaning problem areas, this portion of the meeting could not be left to a later time. As the discussions evolved, these problem areas were noted for inclusion in the summary and for use in formulating recommendations.

1) Why is cleaning necessary? The effects of an accumulation of contamination on reflector (or refractor) surfaces, or on the transparent envelope surrounding the receiver tube, are decreased specular reflectance and decreased performance. Subsequent to severe weather conditions, samples from parabolic trough concentrators have exhibited a drop of 20 to 25 percentage points in specular reflectance. Particulate contaminants such as dust, sand, soot, etc., tend to scatter light and decrease specular intensity. With this effective decrease in reflectance, collector performance is degraded eventually to unacceptable levels. Then cleaning must be performed.

2) What portions of a collector require cleaning? Obviously the reflector or refractor panels must be cleaned. In some collector designs that utilize a transparent cover sheet such as the glazing of a flat plate collector, that sheet must be cleaned just as the reflector of a typical open parabolic trough. Of specific note is the fact that the transparent envelope surrounding (or in front of) the receiver tube must also be cleaned. The personnel responsible for operation of the troughs of the solar irrigation

field at Willard, New Mexico, felt that cleaning of the receiver envelope was perhaps more important than cleaning of the reflector panels.

A separate but associated problem is that of sealing the glass envelope which surrounds or is otherwise in front of the receiver tube. The seal design should prevent, insofar as possible, the infiltration of dust into the interior space between the receiver and its envelope. Dust which settles on the inside surfaces of these glass envelopes is virtually impossible to wash. The design of these receiver assemblies should consider both the preventive aspects as well as the effects of the washing or cleaning process. The Willard, New Mexico, installation has encountered dust infiltration, as have several of the small rim angle receivers which use long, narrow, flat sheets of glass as the transparent envelope. Seals which accommodate the movement due to large temperature excursions are important design challenges.

3) What are the contaminants which accumulate? The contaminants are typically those local soil and other particles which become airborne under windy conditions. Local air pollution studies should provide basic information for cleaning investigations. Other substances such as smog and hydrocarbons condense as films on reflector surfaces. The contaminants may be very dependent on the specific locale and weather conditions of the collector installation.

One of the major areas requiring additional investigation is that of identifying the contaminants which do accumulate and to determine the adhesion mechanisms which develop between collector surface and the foreign particle.

4) How do we clean collectors? The variety of contour and size of reflectors is so broad that providing mechanical scrubbing or agitation, as in a car wash with a rotary brush, will be difficult. Access to the reflector surfaces will be virtually impossible due to the receiver tubes, their supports, guy wires and other items which are unique and necessary. With access denied, the next option appears to be a spray-on/rinse-off approach. Adaptation of spray systems, either fixed or moveable, should be technically feasible for the wide variety of sizes, shapes, and configurations of solar collectors.

The problems of the mechanics of washing were discussed by Dan Arvizu of Sandia. With over two acres of mirror installed at the STTF and getting dirty, there is an immediate need for commitment to a cleaning system. Based on some preliminary investigation, a large roadable piece of high pressure spray equipment was procured for cleaning operations and investigation of cleaning parameters. The unit can supply six gallons per minute at pressures up to 300 psi, with a variety of nozzles and direct injection of the detergent into the spray nozzle at various ratios. The unit has large tanks for deionized water. Operational use of this equipment over the next few months should provide excellent data on problems of cleaning heliostats. Much of this information should be applicable to other types of collectors.

5) How can we decrease the rate of dirt accumulation? Several approaches were mentioned, including storage positions in which the reflector surfaces look downward, preventing settling of particles on the reflector. Some data is available on this design approach. Antistats may be included in the final rinse water to inhibit electrostatic attraction of dirt particles. Glass reflectors may allow baked-on surface coatings which function as antistats. Other more sophisticated approaches were briefly mentioned.

Some measure of the rate of contamination build-up is needed for the various sites of major installations. It was recommended that small test racks might be set up at these sites as soon as possible after selection to provide data on the type of contamination and rates of accumulation for use in planning cleaning cycles and materials. Site-specific contaminants will probably require adjustments in cleaning solutions.

6) How often should we clean? Cleaning frequency is a function of locale, weather, stowage position, reflector material, etc. Estimates of interval range from one week to one month, with two to three weeks predominant. One comment suggested that a regular interval be established and then let the system performance tell you if the cleaning frequency is adequate or not. Certainly, reflectance measurements must be taken to provide correlation with the performance and cleaning data.

7) What is "clean" and how is it measured? In any investigation of cleaning of solar collectors, instrumentation to analyze the efficiency of the cleaning process is vital. Standard reflectance measurement instruments should be used so that the solar community can use data from all sources, on original, dirty, and as-cleaned reflectors. More sophisticated measurements are needed to ascertain what is left on a reflector after the cleaning process; this type of determination would provide information on the efficiency of the cleaning process and on the residue left by it. Both are important parameters.

8) What are cost considerations? Cost considerations are extremely important in developing cleaning processes for large solar fields. Preliminary estimates of the cost of deionized water indicate one cent per gallon of water and $.015\$/ft^2$ per cleaning for spray-on/rinse-off techniques. Detergent costs average about $.035\$/ft^2$ per cleaning. Labor costs are the

potentially large costs requiring from 0.3 to 0.6¢/ft² per washing. Total cleaning costs should not exceed 0.5¢ per ft² per washing for it to be economically viable. Permanently installed sprinkler systems should be investigated to avoid the high labor cost of cleaning by driving a large spray vehicle through the collector field.

Battelle NW has investigated cleaning agents. Manufacturers were contacted for agents, recommended formulations, and washing techniques. Fifty or sixty samples were evaluated. Wetting ability was measured. Most did not leave a residue. Very few were suitable for plastic film reflector materials. Battelle NW ranked the cleaning agents and will furnish information on request.

Environmental protection requirements were only mentioned briefly. The limitations imposed on cleaning systems are real and must be considered in developing cleaning systems.

IDENTIFICATION OF PROBLEM AREAS

1. Contamination and decreased performance is a real problem. Cleaning will be required.
2. Understanding of contamination and adhesion mechanisms is vital.
3. Design must consider both prevention of contamination buildup and adaptation to simple cleaning procedures.
4. Receiver envelopes require cleaning also.
5. Chemical agents to do job will be required. EPA considerations apply.
6. Cleaning techniques must be developed. Minimum water usage is a requirement. Minimum labor is vital.
7. For cleaning system development, instrumentation to measure cleaning efficiency will be required. Residue left by cleaning process must be measured.
8. Cost must be low.

RECOMMENDATIONS

1. Design for cleaning must be an initial design consideration.
2. Investigations are needed into:
 - a. Identification of contaminants: particulate, films, etc.
 - b. Adhesion mechanisms formed between contaminant and reflector.
 - c. Residue left after cleaning.
3. Stowage position and coatings may reduce frequency of cleaning by preventing buildup.
4. Future sites could use data on:
 - a. Types of contamination to be expected.
 - b. Rate of contamination buildup.
 - c. Cleaning requirement projection.

WORKING GROUP ATTENDEES

Session 2 - Group 1

<u>Name</u>	<u>Affiliation</u>
Dan E. Arvizu	Sandia Laboratories
Ronald N. Bracewell	Stanford University
Frank A. Folino	MIT Lincoln Laboratory
Robert L. French	American Technological University
Charles R. Frownfelter	PPG Industries, Inc.
B. P. Gupta	Solar Energy Research Institute
Dave Holdridge	Swedlow, Inc.
Robert O. Hughes	Jet Propulsion Laboratory
Robert W. Jones	Hughes Aircraft Co.
I. Earl Lewis	Ford Aerospace & Communications Corp.
Michael A. Lind	Battelle Pacific Northwest Labs
Bill Saylor	General Electric Co.
Arthur F. Shoemaker	Corning Glass Works
Gardner Weber	Weber Engineering Co.
Paul L. White	Owens-Illinois, Inc.

THIS PAGE INTENTIONALLY LEFT BLANK

HIGH TEMPERATURE RECEIVER MATERIALS PERFORMANCE

Session 2, Group 2

L. Davis Clements, Leader

Department of Chemical Engineering
Texas Tech University
Lubbock, Texas 79409

The group discussions, and this report, center on four primary topics:

- 1) What constitutes high temperature
- 2) Ceramics as receiver materials
- 3) Metals as receiver materials
- 4) Special coatings for solar receivers

The report which follows is an attempt to capture both the emphasis and the flavor of the group discussions.

What Constitutes "High Temperature?"

The first task the group addressed was to decide what constitutes a high temperature receiver on the basis of materials capabilities. The first breakpoint noted is at about 400°C. This constitutes the upper limits for organic heat transfer oils as a working fluid. More importantly the 400°C limit represents the range where austenitic steels replace ferritic steels as a material of construction.

In a materials of construction sense, then, high temperature should encompass the working range for the austenitic steels, the high temperature nickel-based alloys and the super alloys. This suggests a materials high temperature range of about 400°C to 1000°C. Under this definition the Barstow Central Receiver Project, the Crosbyton Fixed Mirror, Distributed Focus system, and a number of lower temperature Brayton cycles would be classed as high temperature receivers. This same range is where high pressure steam, liquid metals, and fused salts appear most attractive as heat transfer media.

At temperatures somewhat below the 1000°C metals limit and for a considerable temperature span above that, ceramics offer tantalizing possibilities as receiver materials. As will be discussed further later, the ceramicists present felt strongly that the primary impediment to development of very high performance ceramic receiver materials is not so much the state of the ceramics art as it is the definition of receiver performance requirements. The group agreed that in terms of materials, temperatures in excess of 1000°C should be considered as ultra-high temperatures. The most common working fluids in this ultra-high temperature range are gases.

It is interesting to note that while the group suggested a temperature breakdown of

intermediate	<	400° C
high		4000° C-1000° C
ultra-high	>	1000° C

the Department of Energy has temperatures classed as

low	<	300° C
intermediate		300-650° C
high	>	650° C

The DOE designations have more to do with the types of energy cycle favored in each range than with the materials requirements. It is recommended that some compromise designation which better matches materials and energy cycles would be more useful.

Ceramics as Receiver Materials

Much of the group's discussion centered on the design and use of ceramics as materials of construction for what we termed ultra-high temperature receivers. It was emphasized that it is difficult, if not improper, to be too specific with regard to the design of a ceramic for a particular receiver situation. The science (art?) of ceramics formulation is still in its youth. However, the problems we are facing in receiver design are such that the receiver materials performance is paramount leaving the economic considerations as secondary. A few specific ceramics and their potential applications and limitations are summarized in Table I.

Table I: Candidate Ceramics for Ultra High
Temperature Solar Receivers

Silicon carbide - A prime candidate material for a coal-powered
Brayton cycle engine.

Properties: $T < 2700^{\circ}\text{F}$
low thermal expansion
high strength
good thermal conductivity
good absorptivity
compatible with many heat
transfer fluids
can be slip cast

Silicon nitride - Compatible with molten aluminum which is a
potential heat transfer fluid.

Cordierite - A magnesium-aluminum silica glass ceramic
for an SO_2 , SO_3 gas receiver.

Properties: $T < 2300^{\circ}\text{F}$
limited to low pressures

Although the pervasive attitude of the ceramicist present seemed to be "tell me your needs and I will design to meet them," there are some non-trivial problems associated with using ceramic receivers. Ceramics have a very real upper limit on internal working pressures of about ten atmospheres. By their nature, ceramics are brittle and this factor must be included as special consideration in any mechanical design.

Also to be included in mechanical design for ceramics is the problem of making joint connections. It is critical that all joints, whether between ceramics or between ceramics and metals, be capable of surviving large temperature variations. The problem of making survivable ceramic/metal joints was identified as critical in the furtherance of ceramic receiver technology.

Although there is a considerable body of knowledge available for ceramics, the transfer of this technology to solar high temperature receivers was identified as a difficult area. For example, ceramics have been used for centuries as refractories, but typically in a reducing atmosphere. When we design a ceramic receiver, it must perform - and survive - in an oxidizing atmosphere and perhaps in contact with a potentially destructive heat transfer medium. As another example, the behavior of ceramics under cyclic temperature conditions is well known, but the response of ceramics to thermal shocking has not been nearly as well explored.

On the positive side, a ceramic receiver provides the prospect of tailoring the material of construction to the performance requirements. Also, the optical properties of some ceramics offer very interesting possibilities. For example, it is well known that in traditional conductive/convective heat transfer, alumina (Al_2O_3) is something less than ideal as a heat exchanger material.

If this same alumina is exposed to radiant energy it is actually somewhat transparent to the energy. The result is that the surface is not overheated relative to the core of material, reducing thermal stresses. There exists, then, the possibility of transferring concentrated heat energy through a receiver directly into the working fluid. The radiant heat transport properties of many candidate receiver materials remain essentially unexplored.

In summary, ceramics are most attractive as a receiver material at temperatures greater than 1000°C, at low pressures, with gaseous heat transfer media. There are significant problems in the brittle design for ceramic receivers and in forming durable mechanical joints, particularly ceramic/metal joints. There are problems also in thermal cycling and thermal shocking and in fluid and ambient environmental compatibility. Ceramic receiver design from both materials and design standpoints is a very young science which seems to be in need of definition of what are the specific receiver performance requirements to be met, and in need of support to find ways to best meet these requirements.

Metals as Receiver Materials

The group's discussion of the role and associated problems of using metals as receiver materials was considerably less lively than the ceramics discussion. The metals industry is a mature industry characterized by a fairly slow, stable rate of development of new materials. In the solar receiver applications area it appears that the nickel-based alloys are the most popular, with the Barstow receiver being fabricated of Incalloy 800 and the Crosbyton receiver being either Inconel 617 or 625.

Several particular problem areas in metal receiver design were noted. Probably the greatest problem is that long term performance data for environmental exposure, corrosion fatigue and

creep/rupture properties under conditions of wide and frequent cycles of temperature and pressure are totally lacking. As with joining ceramics, the transitional junction between metals and the fabrication of the junction is a continuing problem, particularly for the very high temperature metals.

Although exotic, high temperature metals are the subject of an extensive research program, and it appears that the temperature limit for metals is increasing at the rate of about 5°C per year. Typically, the exotic metals are difficult to work with and difficult to join to other metals, although powder metallurgy offers some hopes in receiver fabrication. It was noted that there has been little real transfer of technology for high performance metals such as tantalum and titanium from the chemical process industry to solar application.

A partially non-technical problem encountered in metal receiver design is the lack of an appropriate set of design codes and materials codes. At the present time when designing solar receivers, the designer chooses a procedure based on similarity to conventional pressure vessels, direct fired high pressure boilers, or nuclear power boilers. Efforts towards developing an appropriate code for solar receivers and for expanding the list of code certified metals must be fostered.

Metals are most immediately attractive as a receiver material because of the designer's long term familiarity with them. However, metals have a very definite upper temperature limit which will not likely change significantly with time. Also, the effects of continual thermal and mechanical stress cycling on the metals strength and corrosion performance are effectively unknown.

Special Coatings for Solar Receivers

A number of special coatings for use in solar receivers have been developed or proposed. As the operating temperature range for the receiver changes, the degree and type of selectivity required of a coating also changes. Work done at JPL suggests that below 600°C the primary requirement for a coating is that it be highly selective. In the range 600-1200°C a high absorptivity is most important. For temperatures above 1200°C the coating selectivity is not as important as the receivers for these temperatures tend to be of the cavity type.

The performance required of a coating is highly dependent upon receiver configuration. In the Crosbyton FMDF concept the coating must maintain a high absorptivity up to very large incidence angles and at the same time be able to endure direct environmental exposure. In a cavity receiver a more specular coating is advantageous.

A number of coatings are available which maintain their properties up to about 800°C, but the designer's choices are limited. SERI is presently administering an extensive research program in receiver coating materials and it is hoped that these results will help broaden the choices available. An attractive possibility for some metal receivers is to take advantage of the naturally formed dark oxide coating developed by many metals upon exposure to air. Unfortunately both the optical and the mechanical properties of these oxides have not been adequately characterized. There is a real need to better characterize the temperature limits in absorptivity/selectivity for receiver coatings as well.

WORKING GROUP ATTENDEES

Session 2 - Group 2

<u>Name</u>	<u>Affiliation</u>
Marc A. Adams	Jet Propulsion Laboratory
Porter Arbogast	North American Sun, Inc.
John E. Brzuskiwicz	IIT Research Institute
Larry A. Chick	Battelle Northwest Labs
Terence B. Clark	Ford Aerospace & Communications Corp.
William D. K. Clark	International Nickel Co.
Davis L. Clements	Department Chem. Energy-Texas Tech.
George Cunningham	Lockheed Palo Alto Research Lab
Peter B. Grytness	Mann-Russell Electronics, Inc.
Robert O. Hughes	Jet Propulsion Laboratory
Steve A. Ingham	Pikes Peak Solar Energy Association
Matthew McCargo	Lockheed Palo Alto Research Lab
Kent M. Price	Stanford University
Aaron S. Roy	Oak Ridge National Laboratory
Douglas Rusta	TRW Defense & Space Systems Group
George L. Schrenk	University of Pennsylvania
William R. L. Thomas	Exxon Research & Engineering Co.
J. D. Walton	Georgia Institute of Technology
L. Wen	Jet Propulsion Laboratory

THIS PAGE INTENTIONALLY LEFT BLANK

COLLECTOR PRODUCTION AND MANUFACTURING

Session 2, Group 3

Dave Feasby, Leader

Solar Energy Research Institute

1536 Cole Boulevard

Golden, Colorado 80401

INTRODUCTION

The Production and Manufacturing Workshop was conducted to discuss topics relevant to the production and manufacturing of concentrating collectors. The audience consisted of manufacturers of concentrating collectors, representatives of glass producers, persons active in concentrating collector analysis and research, and persons with general interest within the concentrating collector industry.

The workshop was conducted as a dialogue among the participants to present issues that industry considered important, to facilitate information dissemination among the participants, and to obtain input to various planning efforts. This workshop was particularly important since there is a national plan for commercialization of solar technologies currently being prepared by DOE with input from SERI and others. Therefore, the various comments received during the workshop will be considered for their effect and practicality in assisting the commercialization of concentrator collectors.

ISSUES FOR DISCUSSION

To provide a basis from which to pursue discussion during the workshop, the meeting was open to solicit the relevant issues for this workshop. Following are the issues which were presented for consideration:

- Can the government build a market for materials so that materials manufacturers would be willing to provide materials to the concentrating collector industry at discounted costs for testing and evaluation?
- Can the government provide superficial markets for collectors so the industry can gain access to technologies currently available (i.e., sagged glass)?
- What should be the government's role in demonstrations and what has been the experience of manufacturers regarding the demonstration program to date?
- What are the production problems that currently exist, and how do they relate to the flexibility needed to scale up to mass production?
- What is considered to be mass production and is the industry ready to move into mass production?
- What incentives can be provided by the government to reduce the cost of collectors through mass production?
- What are the values of standards and will they assist the collector industry?

Each of these issues were generally discussed, followed by a detailed discussion on some of the selected issues. Following are some of the general comments which focused on each of the above issues.

Government-Built Material Market

There are various materials available today which must be tested and evaluated to determine their applicability to concentrating collectors. Additionally, there are materials which need to be produced which could have a positive effect on the concentrating collector industry both in terms of flexibility of the material and improved concentrator efficiency. However, because the solar related market for materials is not significant at this time, the collector industry does not get a price break on materials. The materials manufacturers are unwilling to provide significant amounts of materials for test and evaluation and/or unwilling to develop improved materials for collector designs in significant quantities.

To assure material manufacturers that there is a significant market, there is, perhaps, a role that the government could play by purchasing large quantities of materials and providing them to the collector industry at a reduced cost due to the volume purchased. This could help to reduce the overall cost of concentrating collector systems.

Government-Built Artificial Collector Market

The technology for glass manufacturing and forming is available but, if these materials were made available to the collector industry at a reduced cost, the production of a lower cost and more efficient collector unit is possible. The glass industry is currently operating at capacity in providing sagged glass for car windshields. Since the collector market is relatively small or non-existent at this time compared to the auto market, they are unwilling to provide this sagged glass technology to the concentrating collector industry.

If the government could assist in developing an initial market through demonstration programs or large collector procurements, the glass industry would be willing to provide sagged glass for collector manufacturing. The results of this action could help provide lower cost concentrating collectors which could then aid in the commercialization of the solar technologies.

Demonstrations

Demonstrations utilizing concentrating collectors of various types and for various applications are in progress. These demonstrations have been built in several locations throughout the United States and have included different sizes of collector fields. The applications addressed by these demonstrations vary from agricultural uses such as irrigation pumping to food processing and central receiver applications.

Since the demonstrations have an impact on the numbers of collectors produced and consequently can have an impact on driving down the cost of collectors, there may be a role that the government can play and an incentive that the government can provide to the industry. By continuing to conduct demonstrations for various applications of concentrating collectors and by increasing sizes of collector fields, the industry can move into mass production and thus reduce the collector cost.

However, because of the overall question of the government role in commercialization, there seems to be uncertainty within the industry as to the effects of a demonstration program. Moreover, without an experimental facility to validate design and optimization criteria, the demonstration program can not achieve its full potential.

Production Considerations and Problems

The low market penetration at this point in time presents a problem associated with the production of concentrating collectors. Also, the collector production technique needs to have a certain degree of flexibility to accommodate larger production quantities in the future. However, at this time most of the production techniques do not provide for this flexibility because the materials used require a specific process and technique for production which may become antiquated as new materials become available.

Industrial representatives expressed the concern that some of the current production techniques may become outdated and require extensive cost and modification to accommodate materials that are expected to become available in the near future. They are also concerned that by developing a specific collector design based on existing materials, it may not allow them the flexibility to move into other production techniques without incurring significant cost to do so.

Mass Production Problems

Furthermore, most collectors are produced by soft tooling or by hand. There is no current manufacturer who has invested large sums of money for mass production of concentrating collectors. However, some have made a commitment to do so and will soon be moving into a hard tooling mode to increase the amount of collectors they can produce. A concurrent problem that may exist is the availability and the ability of ancillary industries to produce materials or equipment required in the production of collectors. For example, the production of mirror surfaces, the production of gears for tracking systems, or the production of components required for control systems, etc. One of the glass

manufacturers present indicated that they currently have excess capacity that could be devoted to new production of mirrors for the concentrating collector industry. However, based on the current market demand, there is little prospect of cost reduction from the glass manufacturers to help reduce the cost of the collector systems.

Standards

Some of the manufacturers raised the issue of the advantages or disadvantages of providing standards for the concentrating collector industry. Since the government in the past has provided requirements for standards, the question is whether the standards would be an incentive or a disincentive for the collector industry. The standards that were discussed included performance standards as well as equipment and component standards.

DETAILED DISCUSSIONS

Following the general comments about the above issues, there were primarily four issues that were selected for more detailed discussion. These four issues were: Industry Concerns and/or Problems, Incentives for Consumers and Industry, Demonstration Projects, and Standards.

Industry Concerns and/or Problems

Representatives of the glass manufacturing industry, collector and system manufacturers, and others present at this workshop discussed some of the problems associated with mass production of concentrating collector systems. One of the glass manufacturers indicated that they currently have the production capability to produce larger quantities of mirrored surfaces. They are currently producing about 100,000 square feet of mirrors per day

and could easily build to 250,000 square feet per day. However, the allocation of that mirror production to the concentrator collector industry would be dependent upon an indication of a significant demand for the solar collectors.

Of particular interest was the silvering of surfaces; curved surfaces particularly. If the industry were to move into mass production, there would be a need for automation of the process for silvering of mirrored surfaces--a process which is currently done manually. To develop the automation capability would require the design of equipment to perform this function. The automation equipment can be designed and built and could possibly result in a guarantee of a 20-year life on the mirrored surfaces.

Of major concern within the industry is a way of creating the demand for concentrating collector systems. If the customers existed, the industry could move rather quickly into mass production to meet the consumer demand.

Incentives for Consumers and Industry

In addition to the government purchase of materials, other ways of providing incentives to consumers and the industry were discussed. One of the consumer incentives suggested was a tax rebate, similar to what is being proposed in the national energy program for heating and cooling. This would include direct subsidies to consumers from the government by providing them a sum of money to participate in solar, a means of better financing for purchase of solar equipment by making loans available to consumers at favorable interest rates, and allowance to expense the solar equipment in one year rather than the present regulation requiring amortization over a long period of time.

Another way to increase consumer participation in solar is to provide consumer publicity or information which is in the proper format so that the consumer can understand it and assure that it is correct. It seems that many facts are thrown around regarding solar; particularly the costs, lifetime applications, etc., which cause the consumer to get a rather unclear picture or erroneous picture about what they can expect from solar. Proper and authoritative information dissemination would be a way of correcting this problem.

Among the recommendations for governmental incentives which could be made available to industry are funding of programs for the development of advanced materials and/or production development techniques, the declining investment tax credit, and direct government buys of concentrating collector systems.

Demonstration Projects

The government has participated in demonstration programs for various solar technologies, including those utilizing concentrating collectors. The existing demonstration programs and those of the future are important to the industry because they develop a market for concentrating collector systems. Additionally, demonstrations can be used as a means of bringing the technologies and applications to consumers by showing that these technologies work and have application on a wider basis. To get broader visibility, it might be advantageous to have many small demonstrations spread out throughout the country so that consumers could see within their "neighborhoods" that solar is here now and works. With large demonstration projects, the government can assist in increasing the demand for collectors.

Some of the attendees expressed their concern about the possibility of the demonstration projects winding down. The demonstration programs to date have helped to bring new manufacturers into the industry, and the possibility of reduced funding for demonstrations could have just the opposite effect. Additionally, the demonstration projects can provide a broad base for data collection which, if properly disseminated, can assist consumers in realistically evaluating the performance, costs, lifetime, and other data on how various collectors perform in specific regions.

Standards

Two opposing views were prevalent in the group. However, the majority sided with the viewpoint that standards in collector design are an evolutionary process which will be developed by the industry as it matures, and if imposed too quickly on a developing industry, can have some unpredictable and possibly negative effects. Standards, if too restrictive, can limit future systems from qualifying for industrial applications. Since there is a continuing need for innovative approaches, materials, and systems to help reduce the cost of collectors standards may limit this innovation.

The other viewpoint was the positive effect of design standardization. If such standards are not too severe and are properly emphasized, then they could help move the industry into mass production by dealing only with standardized components. This argument may be particularly true if the mass production process or tooling used can provide the necessary flexibility of modifications in the future.

CONCLUSION

In conclusion, there are some acknowledged manufacturing and production problems which exist in the concentrating collector industry. However, the most significant of these is the lack of early market penetration of what appears to be a large market potential. Any action that can be taken by the government (i.e., incentives to the industry itself or direct incentives to consumers to procure concentrating collector systems) to assist the industry in reducing the apparent collector costs can have a positive effect in the near term.

WORKING GROUP ATTENDEES

Session 2 - Group 3

<u>Name</u>	<u>Affiliation</u>
Joseph Bezborodko	Mechanical Mirror Works, Inc.
Lynn S. Brock	Harrison Radiator Div. GMC
Martin DeVries	Donnelly Mirrors, Inc.
Edgar Durbin, Jr.	BDM Corporation
John R. Egger	Optical Sciences Group
James Eibling	Battelle-Columbus
Jim Henderson	Motorola
Gerald Litzinger	Acurex Corp.-Alternate Energy Div.
George Lymbouris	Economist
William D. Miller	Martin Marietta Corporation
George Motnyk	Horizon Solar Corporation
R. D. Pohl	Gardner Mirror Co.
Roy Rainhart	Sandia Laboratories
Roger Riggs	Thermal Dynamics, Inc.
Hugh Smith	Ford Aerospace & Communications Corp.
Dan Stolarczyk	Morse Borg Warner
Jeffrey J. Zimmerman	General Electric Co.

THIS PAGE INTENTIONALLY LEFT BLANK

LINE FOCUS RECEIVER TECHNOLOGY

Session 2, Group 4

Howard Gerwin, Leader

Sandia Laboratories
Albuquerque, New Mexico

This subject area was of interest to a number of participants at the symposium and, therefore, a lively discussion took place in this working group. A few topics were selected for discussions, a summary of which is presented here.

Line Focus Receiver Application

Line focus receivers are employed in various collector designs. The upper temperature limit of application of line focus receivers depends on the actual collector design but the consensus was that for high temperatures, point focus collectors may be better suited. Selective coating materials and heat transfer fluids are the primary limitations for both line and point focus high temperature solar systems. Line focus collectors require less critical tracking and control sensitivities relative to the point focus collectors. For photovoltaic applications, a line focus receiver provides uniformity of concentrated flux which results in improved cell output. The cooling water, used in case of active cooling of solar cells, can provide thermal energy for secondary use.

Tracking Receivers Versus Tracking Reflectors

Considerations for comparing which part of the collector does the moving centered on the hardware. If flexible tubes or swivel pipe connections are reliable in the system, both approaches are viable. No flexible hose failures were reported; however, swivel connector availability is considered a problem, especially above 300°C. To make available more design flexibility, swivel connectors should be studied and developed further.

Absorber and Receiver Sagging

When receiver tubes sag between supporting structures the optimum receiver focus line is shifted and enlarged. This effect is accentuated in the early morning and late afternoon because of the larger incidence angles depending on orientation. Besides gravity, thermal gradients absorber sag. One design, using 3.8-cm diameter tube on 3-m supports, had a sag of 0.25 mm. A Sandia design had 4.1-cm tubes on 3.7-m supports but is being redesigned with closer spacing of the support members to reduce the amount of sag.

Glass Envelopes

Nearly all linear receiver designs use glass envelopes to reduce convective conductance losses. Experience at the Gila Bend irrigation project was reported where improved performance was observed after glass envelopes were replaced by semicircular insulation on the back side of the absorber tubes. The original glass had been losing transmissivity because of internal moisture and dust. The main problem with the concentric glass tubes appears to be with the end seals for dust and moisture while still providing allowance for the differential expansion between metal absorbers and glass enclosures.

Inflated Transparent Cover

A transparent cover enclosing the entire collector should offer several advantages and Boeing is completing a study of this approach. Convection losses are thought to be the same as with glass envelopes except for wind conditions. Estimates suggest that due to the wind, thermal losses may increase by a factor of five. A significant advantage is that selective coatings and reflective surface would be shielded by the cover from the dust and other environmental effects.

Transfer Fluid - Water Versus Oil

Since water has about 18 times the heat capacity of oil, water should be better. For high temperature operation, significant pressures are then required to prevent the generation of steam. Using the receivers as boilers was discussed, however, with mostly negative comments because of increased safety concerns plus the fact that steam has a lower heat capacity. The cross section for thermal input would be lower than with liquid in the receiver tubes.

One study had concluded that the pumping power required in case of oil exceeds that required for water for an equivalent amount of heat transferred. When water is used in the receivers, special water treatment becomes necessary to minimize corrosion problems. The water treatment need gets more significant at higher temperature operation.

Heat Pipes

Although no experience in the use of heat pipes in receivers was shared, some participants expressed interest in the approach. Lighter receivers might be obtained, thus sagging might be

reduced. Heat pipe was used in a parabolic trough collector used in research activities but the potential for heat pipe use in commercial solar collectors needs to be fully evaluated.

Collector Design With Low Rim Angle Reflectors and Secondary Concentrators

Relative effectiveness of low rim angle ($<40^\circ$) collector designs is not clearly understood. The discussions brought forth the following important characteristics of such designs:

- Smaller receiver tubes can be used if secondary concentrators are incorporated.
- Large rim angles will have larger total reflector surface area compared to low rim angle reflectors of the same aperture size.
- With low angle and secondary concentrators, higher temperatures can be achieved since the heat loss may be reduced more effectively.
- Extra obscuration of the primary reflector can be eliminated by using a secondary concentrator with only backside insulation e.g., compound parabolic concentrator (CPC).
- Low rim angle designs offer an advantage for photovoltaics (PV).

Flux Mapping

Solar flux maps of linear receivers can be especially useful for PV applications because of the sensitivity of solar cell output to flux uniformity. Three methods of mapping were offered:

- Variable collimation and corresponding power measurement.

- Infrared scanning, but glass covers would be a problem because IR is not transmitted.
- Photographic film in conjunction with a shutter to control exposure time.

THIS PAGE INTENTIONALLY LEFT BLANK

WORKING GROUP ATTENDEES

Session 2 - Group 4

<u>Name</u>	<u>Affiliation</u>
Graham H. Alexander	Battelle-Columbus Laboratories
Jerry O. Bradley	Desert Research Institute
Jeffrey E. Christian	Oak Ridge National Lab
Arnold F. Clark	Lawrence Livermore Laboratory
Milan H. Cobble	New Mexico State University
Costa G. Constantino	Pikes Peak Solar Energy Association
Howard J. Gerwin	Sandia Labs
Brian Howard	Sun Heet, Inc.
Louis C. P. Huang	Navy Civil Engineering Lab
H. R. Hull	Hexcel Corporation
Steve A. Ingham	Pikes Peak Solar Energy Association
Stephen I. Kaplan	Oak Ridge National Lab
Conrad Lanza	IBM Research Lab
Robert F. Mattson	EIA
Ari Rabl	Argonne National Lab
Arthur C. Ratzel	Sandia Labs
George F. Russell	Mann-Russell Electronics, Inc.
Johanna S. Schruben	Westinghouse R & D
Karl E. Sterne	Direct Energy Corporation
William C. Thomas	Virginia Polytechnic Institute
Byard D. Wood	Arizona State University

THIS PAGE INTENTIONALLY LEFT BLANK

CONCENTRATING COLLECTOR SYMPOSIUM

List of Attendees
June 14 - 15, 1978

Marc A. Adams
JPL
4800 Oak Grove Drive
Pasadena, CA 91103
213-354-2056

Graham H. Alexander
Battelle-Columbus Laboratories
505 King Avenue
Columbus, OH 43201
614-424-7709

Raymond H. Anderson
3M Company
3M Center, Bldg 735-2N
St. Paul, MN 55101
612-733-2023

William D. Antrim
American Science
955 Nass Ave.
Cambridge, MA 02139
617-868-1600 x414

Walter J. Apley
Battelle Pacific Northwest Labs
Battelle Blvd.
Richland, WA 99352
509-946-3748

Porter Arbogast
North American Sun, Inc.
Box 379
Marshall's Creek, PA 18335
717-588-9762 (evenings)

Dan E. Arvizu
Sandia Laboratories
Div. 5713
Albuquerque, NM 87110
505-264-7844

Kirt W. Bailey
Colorado Technical College
3100 N. Wood Ave. F14
Colorado Springs, CO 80907

Donald H. Baltzer
3M Visual Products Div.
235-3D
St. Paul, MN 55101
612-736-0522

Calvin B. Beatty
Berry Solar Products
P.O. Box 327
Edison, NJ 08817
201-549-3800

Miriam E. Beesing
Honeywell, Inc.
2600 Ridgeway Parkway
Mn19-T123
Minneapolis, MN 55410
612-378-5413

Joseph Bezborodko
Mechanical Mirror Works, Inc.

Connie Blake
7102 S. Franklin St.
Littleton, CO 80122
303-798-0368

John Blake
7102 S. Franklin St.
Littleton, CO 80122
303-798-0368

Ronald N. Bracewell
Stanford University
E. E. Department
Stanford, CA 94305
415-497-3545

Jerry O. Bradley
Desert Research Institute
1500 Buchanan Blvd.
Boulder City, NV 89005
702-293-4217

George P. Branch
Hexcel Corporation
11711 Dublin Blvd.
Dublin, CA 94536
415-828-4200

Harri J. Brax
W. R. Grace & Co., Cryovac Division
P. O. Box 464
Duncan, SC 29334
803-433-2700

Lynn S. Brock
Harrison Radiator Div., GMC
Upper Mountain Road, Bldg. 6
Lockport, NY 14094
716-439-3115

Ken Brown
Solar Energy Research Institute
1536 Cole Blvd.
Golden, CO 80401
303-234-7400; FTS-327-7400

John E. Brzuskiwicz
IIT Research Institute
10 W. 35th St.
Chicago, IL 60616
312-567-4369

Jim Castle
Solar Energy Research Institute
1536 Cole Blvd.
Golden, CO 80401
303-234-7128; FTS-327-7128

John A. Castle
Spectrolab, Inc.
12500 Gladstone Ave.
Sylmar, CA 91342
213-365-4611

Roscoe L. Champion
Sandia Labs Div. 5722
Albuquerque, NM 87185
505-264-8643

Jack M. Cherne
TRW
1 Space Park
Redondo Beach, CA 90278
213-536-1955

Larry A. Chick
Battelle Northwest Labs
BNW, Battelle Blvd.
Richland, WA 99352
509-946-2076

Percy E. Chorley
Avica Equipment, LTD
Hemel Hempstead
England
0442-64711

Jeffrey E. Christian
Oak Ridge National Lab
P. O. Box X
Oak Ridge, TN 37921
615-483-6811

Arnold F. Clark
Lawrence Livermore Laboratory
P. O. Box 808 L-47
Livermore, CA 94550
415-422-1458

Terence B. Clark
Ford Aerospace & Communications Corp.
Aeronutronic Division
Ford Road
Newport Beach, CA 92663
714-759-5993

William D. K. Clark
International Nickel Co.
Sterling Forest
Suffern, NY 10901
914-753-2761 x275

Davis L. Clements
Department of Chemical Energy
Texas Technology University
Lubbock, TX 79409
806-742-3553

Milan H. Cobble
New Mexico State University
Las Cruces, NM 88003
505-616-3501 x505

Kirk R. Collier
Los Alamos Scientific Lab
Box 1663 MS 571
Los Alamos, NM 87545
505-667-2241

Costa G. Constantino
Pikes Peak Solar Energy Association
P. O. Box 4913
Colorado Springs, CO 80930
303-633-9404

George Cunnington
Lockheed Palo Alto Research Lab
3251 Hanover St.
Palo Alto, CA 94304

Doug Danielson
Morse Div. Borg Warner
7594 S. Willow Circle
Englewood, CO 80112
303-770-1965

M. M. Delgado
Jacobs-DeI Solar Energy Systems, Inc.
905 Monterey Pass Road
Monterey Park, CA 91754
213-264-5900

Paul A. Delgado
DeI Manufacturing Co.
905 Monterey Pass Road
Monterey Park, CA 91754
213-264-5900

Martin DeVries
Donnelly Mirrors, Inc.
49 W. Third Street
Holland, MI 49423
-394-2348

Edgar Drubin, Jr.
BDM Corporation
7915 Jones Branch Drive
McLean, VA 22101
703-821-5130

Alan L. Edgecombe
Solar Energy Research Institute
1536 Cole Blvd.
Golden, CO 80401
303-234-7244; FTS 327-7244

John R. Egger
Optical Sciences Group
24 Tiburon St.
San Rafael, CA 94901
415-453-8980

James Eibling
Battelle-Columbus
505 King Ave.
Columbus, OH 43201
614-424-7898

James G. Frommeyer
Sun Trac Corp.
1674 S. Wolf Road
Wheeling, IL 60090
312-541-2095

H. E. Felix
Solaramics, Inc.
1301 East El Segundo Blvd.
El Segundo, CA 90245
213-322-9302

James K. Fisher
Honeywell Energy Resources Center
2600 Ridgway Parkway, MN17-T789
Minneapolis, MN 55413
612-378-5437

Frank A. Folino
MIT Lincoln Laboratory
Wood St.
Lexington, MA 02173
617-862-5500 x7424

Robert L. French
American Technological University
P. O. Box 1416
Killeen, TX 76541
817-526-1271/1171

Melvin W. Frohardt
Martin Marietta Corporation
P. O. Box 179
Denver, CO 80201
303-973-4988

Charles R. Frownfelter
PPG Industries, Inc.
One Gateway Center
Pittsburgh, PA 15222
412-434-2644

John D. Garrison
San Diego State University
Physics Department
San Diego, CA 92182
714-286-6240

Harry W. Gaul
Solar Energy Research Institute
1536 Cole Blvd.
Golden, CO 80401
303-234-7246; FTS 327-7246

Howard J. Gerwin
Sandia Labs
Division 5721 KAFB-East
Albuquerque, NM 87185
505-264-6394

Robert W. Gilmer
Institute for Energy Analysis
Oak Ridge Associated Universities
Oak Ridge, TN 37830
615-483-8411 x354

George G. Goranson
DEL Manufacturing Co.
905 Monterey Pass Road
Monterey Park, CA 91754
213-264-5900

Derrick P. Grimmer
Los Alamos Scientific Lab
Q-11, MS-571
Los Alamos, NM 87545
505-662-6441

Petter B. Grytness
Mann-Russell Electronics, Inc.
1401 Thorne Road
Tacoma, WA 98421
206-383-1591

B. P. Gupta
Solar Energy Research Institute
1536 Cole Blvd.
Golden, CO 80401
303-234-7140; FTS 327-7140

Jim Henderson
Motorola
8201 East McDowell Road
Scottsdale, AZ 85252
602-949-4171

E. Michael Henry
TEAM, Inc.
P. O. Box 672
Springfield, VA 22150
703-971-3050

Samuel L. Hensel
Electronic Space Systems Corporation
Old Powder Mill Road
Concord, MA 01742
617-369-7200

Dave Holdridge
Swedlow, Inc.
12122 Western Ave.
Garden Grove, CA 92642
714-893-7531

Ray S. Horrall
Morse Chain Borg Warner
4650 N. Steele
Denver, CO
303-825-7134

Brian Howard
Sun Heet Inc.
2624 S. Zuni
Englewood, CO 80110
303-922-6179

Louis C. P. Huang
Navy Civil Engineering Lab
Code L63, CEL, NCRC
Port Hueneme, CA 93043
805-982-5974 or 4207

Robert O. Hughes
Jet Propulsion Laboratory
4800 Oak Grove Drive
Pasadena, CA 91103
213-577-9274

H. R. Hull
Hexcel Corporation
11711 Dublin Blvd.
Dublin, CA 94536
415-828-4200

Gus Hutchison
Solar Kinetics, Inc.
147 Parkhouse St.
Dallas, TX 75207
214-747-6519

Steve A. Ingham
Pikes Peak Solar Energy Association
P. O. Box 4913
Colorado Springs, CO 80930
303-633-9404

Richard W. Jaminski
Honeywell, Inc.
2600 Ridgway Parkway, MN17-T540
Minneapolis, MN 55413
612-378-5496

David R. Johnston
Planning Research Corp.
7600 Old Springhouse Rd.
McLean, VA 22101
701-893-1822

Robert W. Jones
Hughes Aircraft Co.
Culver City, CA 90230
213-391-0711 x2311

Stephen I. Kaplan
Oak Ridge National Lab
P. O. Box X
Oak Ridge, TN 37830
615-483-8611 x3-1987

John C. Kiminas
Olympic Solar Plating Corp.
208 15th St., SW
Canton, OH 44707
216-452-8856

James Knister
Donnelly Mirrors, Inc.
49 W. Third Street
Holland, MI 49423
-394-2321

John H. Laakso
Boeing Engineering & Construction
Mail Stop 8K-70
P. O. Box 3707
Seattle, WA 98124
206-773-9853

Conrad Lanza
IBM Research Lab
T. J. Watson Research Center
P. O. Box 218
Yorktown Heights, NY 10598

W. R. Lee
Swedlow, Inc.
12122 Western Avenue
Garden Grove, CA 92645
714-893-7531

James A. Leonard
Sandia Laboratories
Albuquerque, NM 87185
505-264-8508

Donald J. Levy
Lockheed Research Laboratories
3251 Hanover
Palo Alto, CA 94304
415-493-4411 x5616 or 5408

I. Earl Lewis
Ford Aerospace and Communications Corp.
3939 Fabian Way
Palo Alto, CA 94303
415-494-7400 x4429

Michael A. Lind
Battelle Pacific Northwest Labs
Battelle Blvd.
Richland, WA 99352
509-946-3676

Gerald Litzinger
ACUREX Corp. Alternate Energy Division
485 Clyde Ave.
Mt. View, CA 94042
415-964-3200

Gorge Lymbouris
Economist
2915 Hudson St.
Colorado Springs, CO 80910
303-633-9404

Herman Malone
Rocky Mountain Electric
3121 E. Colfax Ave.
Denver, CO 80207
303-399-5852

Keith Masterson
Solar Energy Research Institute
1536 Cole Blvd.
Golden, CO 80401
303-234-7111; FTS 327-7111

Robert F. Mattson
EIA
2681 S. Zurich Ct.
Denver, CO 80219
303-935-5151

Matthew McCargo
Lockheed Palo Alto Research Lab
3251 Hanover St.
Palo Alto, CA 94304
415-493-4411, x45193

Michael McGrail
Mansfield State College
Box 457 Maple B
Mansfield, PA 16933

Roy W. Miller
American Science & Engineering
955 Massachusetts Ave.
Cambridge, MA 01775
617-868-1600

William D. Miller
Martin Marietta Corporation
SOSSO
P.O. Box 179
Denver, CO 80201
303-973-4267

W. D. Mitchell
Solaramics, Inc.
1301 E. El Segundo Blvd.
El Segundo, CA 90245
213-322-9302

Stanley W. Moore
Los Alamos Scientific Lab
Los Alamos, NM 87545
505-667-6441

George Motnyk
Horizon Solar Corp.
328 Link Lane #5
Ft. Collins, CO 80521
303-221-1232

Albert F. Naccach
Aton Solar Manufacturing
20 Pamaron Way, G
Novato, CA 94947
415-883-0866

Dean O. Phillips
A & J Manufacturing Co.
2801 South Tejon
Englewood, CO 80110
303-781-5597

Steven Pohlman
Solar Energy Research Institute
1536 Cole Blvd.
Golden, CO 80401
303-234-7226; FTS 327-7226

S. A. Pollack
TRW Systems, Inc.
One Space Park
Redondo Beach, CA 90278
213-536-2260

Rolf-Dieter Pohl
Gardner Mirror Corp.
P. O. Box 638
No. Wilkesboro, NC 28659
919-838-2111

Kent M. Price
Stanford University
Electrical Engineering Department
Stanford, CA 94305
415-497-3548

John Powers
ALCOA
Alcoa Tech. Center
Alcoa Center, PA 15069
412-339-6651

William J. Putman
Desert Sunshine Exposure Tests, Inc.
Box 185, Black Canyon Stage
Phoenix, AZ 85020
602-465-7525, 21

Ari Rabi
Argonne National Lab
Argonne, IL 60439
312-972-6240

Roy Rainhart
Sandia Laboratories
P. O. Box 5800
Albuquerque, NM 87185
505-264-6222

Arthur C. Ratzel
Sandia Laboratories
Albuquerque, NM 87115
505-264-4256

LaVerne W. Rees
Suntec Systems, Inc.
2101 Wooddale Drive
St. Paul, MN 55119
612-735-7600

Michael E. Resner
Department of Energy
Washington, DC 20545
202-376-1941

Luther E. Rhoades
ESSCO
Old Powder Mill Road
Concord, MA 01742
617-369-7200 x43

Roger Riggs
Thermal Dynamics, Inc.
2285 Emerald Heights Court
Reston, VA 22091
703-620-3014

Charles F. Ritter
Morse Chain Div. Borg Warner
3366 Fruitland Ave.
Los Angeles, CA 90058
800-372-6435

William E. Rogers
Rensselaer Polytechnic Institute
EC 2049-Mechanical Engineering
Troy, NY 12181
518-270-6427

Edward L. Rossiter
ACUREX Corp. Alternate Energy Div.
485 Clyde Ave.
Mt. View, CA 94042
415-964-3200

David Rostoker
Pittsburgh Corning Corp.
800 Presque Isle Dr.
Pittsburgh, PA 15239
412-327-6100 x242

Aaron S. Roy
Oak Ridge National Laboratory
P. O. Box X
Oak Ridge, TN 37830
615-483-8611, x3-6558

Jack Ruff
Honeywell Energy Resources Center
2600 Ridgway Parkway
Minneapolis, MN 55112
612-378-4175

George F. Russell
Mann-Russell Electronics, Inc.
1401 Thorne Road
Tacoma, WA 98421
206-383-1591

Dan Sallis
Custom Engineering
2805 S. Tejon
Englewood, CO 80110
303-761-7585

J. Matthew Sandor
Solar Energy Research Institute
1536 Cole Blvd.
Golden, CO 80401
303-234-7232 FTS 327-7232

Stephen L. Sargent
Program Manager
Department of Energy
20 Massachusetts Ave.
Washington, DC 20545
202-376-9642

Bill Saylor
General Electric Co.
P. O. Box 8555
Philadelphia, PA 19101
215-962-5230

George L. Schrenk
University of Pennsylvania
41 Spring Mill Lane
Cherry Hill, NJ 08003
609-428-7767

Johanna S. Schruben
Westinghouse Research and Development
1310 Beulah Road
Pittsburgh, PA 15235
412-256-3611

Blynn D. Shafer
Sandia Labs
Kirtland Air Force Base East
Albuquerque, NM 87185
505-264-8221

Arthur F. Shoemaker
Corning Glass Works
Advanced Products Dept. Bldg. 8-5
Corning, NY 14830
607-974-7630

Barry Skolnick
National Metalizing of New Jersey
Cranbury, NJ
609-655-4000

Maxwell M. Small
Brookhaven National Laboratory
Bldg. 318
Upton, NY 11973
516-345-2490

Hugh Smith
Ford Aerospace & Communications Corp.
3939 Fabian Way
Palo Alto, CA 94303
415-494-7400

Robert W. Spotts
University of Colorado
Colorado Springs Campus
226 E. Madison Ave.
Colorado Springs, CO 80907
303-633-4862

Shirley A. Stadjuhar
Solar Energy Research Institute
1536 Cole Blvd.
Golden, CO 80401
303-234-7110; FTS 327-7110

Karl E. Sterne
Direct Energy Corporation
16221 Construction Circle W.
Irvine, CA 92714
714-552-6211

Dan Stolarczyk
Morse Borg Warner
305 Mission St.
San Rafael, CA 94901
415-453-0623

Barry D. Symmonds
NPD Energy Systems Inc.
Farmington Commons
Farmington, CT 06107
203-677-7667

Roger W. Taylor
Arizona Public Service Co.
P. P. Box 21666 Station 1795
Phoenix, AZ 85036
602-271-2431

Alfred J. Thelen
Optical Coating Laboratory, Inc.
2789 Giffen Ave.
Santa Rosa, CA 95401
707-545-6440

William C. Thomas
Virginia Polytechnic Institute
Mechanical Engineering Department
Blacksburg, VA 24061
703-951-6953

William R. L. Thomas
Exxon Research & Engineering Co.
Room B129, Bldg. 28
Linden Avenue
Linden, NJ 07036
201-474-2180

William E. Tragert
NPD Energy Systems Inc.
1455 Research Blvd.
Rockville, MD 20850
301-424-4870

Jim Tobias
Honeywell
2600 Ridgway Parkway
Minneapolis, MN 55413

Kenell J. Touryan
Sandia Laboratories
Kirtland Air Force Base
Albuquerque, NM 87115
505-264-5341

Vincent Truscello
Jet Propulsion Laboratory
4800 Oak Grove Dr.
Pasadena, CA 91103
FTS 792-9367

R. Viswanathan
Hughes Aircraft Co.
Mail Station D-133
Culver City, CA 90230
213-391-0711 x21575

Wayne Walters
Honeywell Energy Resources Center
2600 Ridgway Parkway
Minneapolis, MN 55413
612-379-1141

J. D. Walton
Georgia Institute of Technology
Atlanta, GA 30332
404-894-3661

Lloyd Wartes
SEIA
550 E. 12th Avenue
Denver, CO 80302

Gardner Weber
Weber Engineering Co.
904 N. Weinbach Ave.
Evansville, IN 47711
812-473-0064

Laura S. Welch
Spectrolab, Inc.
12500 Gladstone Ave.
Sylmar, CA 91342
213-365-4611

L. Wen
Jet Propulsion Laboratory
4800 Oak Grove Dr.
Pasadena, CA 91103
213-577-9270

Gregory M. White
Solar Energy Research Institute
1536 Cole Blvd.
Golden, CO 80401
303-234-7246; FTS 327-7246

Paul L. White
Owens-Illinois, Inc.
P. O. Box 1035 - NTC
Toledo, OH 43666
419-247-8859

Roland Winston
University of Chicago
Chicago, IL 60637
312-753-8654

Byard D. Wood
Arizona State University
College of Engineering
Tempe, AZ 85287
602-965-7298

John C. Yeoman
Oak Ridge National Laboratory
Oak Ridge Term. Box X
Oak Ridge, TN 37830
615-483-8611 x3-1784

Peter P. Zemanick
Westinghouse Advanced Energy Systems Div.
P. O. Box 10864
Pittsburgh, PA 15236
412-892-5600 x5148

Jeffrey J. Zimmerman
General Electric Co.
P. O. Box 8661 Rm. 7524
Philadelphia, PA 19101
215-962-3776

Solomon Zwerdling
Northeast Solar Energy Center
70 Memorial Drive
Cambridge, MA 02142
617-661-3500

Hugh C. Barnes
Reynolds Metals Co.
1519 Summit Ave.
P. O. Box 27003
Richmond, VA 23261
804-788-7519

A. C. Benning
Harshaw Chemical Co.
1945 E. 97th Street
Cleveland, OH 44106
216-721-8300

Ed Christenson
Solar Engineering Tech. Department
Colorado Technical College
655 Elkton Dr.
Colorado Springs, CO 80907
303-598-0200

Frank Kreith
Solar Energy Research Institute
1536 Cole Blvd.
Golden, CO 80401
303-234-7109; FTS 327-7109