

535
12-18-81
EW

①
STOCK
#6 cys

I-480 DL 151

LBL-13260
UC-66b



Lawrence Berkeley Laboratory

UNIVERSITY OF CALIFORNIA

EARTH SCIENCES DIVISION

MASTER

RECENTLY DEVELOPED WELL TEST INSTRUMENTATION FOR
LOW-TO-MODERATE TEMPERATURE HYDROTHERMAL RESERVOIRS

R. Solbau, C.B. Goranson, and S.M. Benson

August 1981

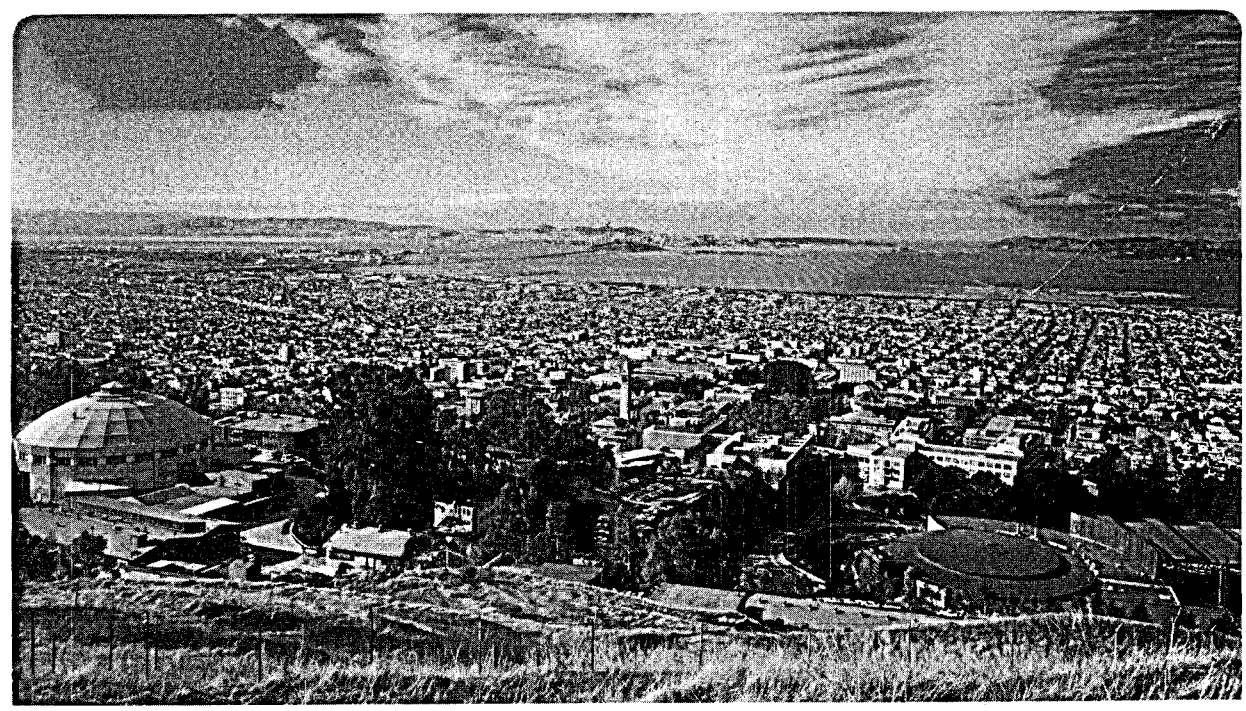

Prepared for the U.S. Department of Energy under Contract W-7405-ENG-48

DISTRIBUTION OF THIS DOCUMENT IS UNLIMITED

DISCLAIMER

This report was prepared as an account of work sponsored by an agency of the United States Government. Neither the United States Government nor any agency Thereof, nor any of their employees, makes any warranty, express or implied, or assumes any legal liability or responsibility for the accuracy, completeness, or usefulness of any information, apparatus, product, or process disclosed, or represents that its use would not infringe privately owned rights. Reference herein to any specific commercial product, process, or service by trade name, trademark, manufacturer, or otherwise does not necessarily constitute or imply its endorsement, recommendation, or favoring by the United States Government or any agency thereof. The views and opinions of authors expressed herein do not necessarily state or reflect those of the United States Government or any agency thereof.

DISCLAIMER

Portions of this document may be illegible in electronic image products. Images are produced from the best available original document.

LEGAL NOTICE

This book was prepared as an account of work sponsored by an agency of the United States Government. Neither the United States Government nor any agency thereof, nor any of their employees, makes any warranty, express or implied, or assumes any legal liability or responsibility for the accuracy, completeness, or usefulness of any information, apparatus, product, or process disclosed, or represents that its use would not infringe privately owned rights. Reference herein to any specific commercial product, process, or service by trade name, trademark, manufacturer, or otherwise, does not necessarily constitute or imply its endorsement, recommendation, or favoring by the United States Government or any agency thereof. The views and opinions of authors expressed herein do not necessarily state or reflect those of the United States Government or any agency thereof.

Printed in the United States of America
Available from
National Technical Information Service
U.S. Department of Commerce
5285 Port Royal Road
Springfield, VA 22161
Price Code: A03

**Recently Developed Well Test Instrumentation
for Low-to-Moderate Temperature Hydrothermal Reservoirs**

R. Solbau, C. B. Goranson* and S. M. Benson

**Earth Sciences Division
Lawrence Berkeley Laboratory
University of California
Berkeley, California 94720**

August, 1981

DISCLAIMER

This book was prepared as an account of work sponsored by an agency of the United States Government. Neither the United States Government nor any agency thereof, nor any of their employees, makes any warranty, express or implied, or assumes any legal liability or responsibility for the accuracy, completeness, or usefulness of any information, apparatus, product, or process disclosed, or represents that its use would not infringe privately owned rights. Reference herein to any specific commercial product, process, or service by trade name, trademark, manufacturer, or otherwise, does not necessarily constitute or imply its endorsement, recommendation, or favoring by the United States Government or any agency thereof. The views and opinions of authors expressed herein do not necessarily state or reflect those of the United States Government or any agency thereof.

***Present address: Berkeley Group, Inc., 245 Gravatt Drive, Berkeley, California, 94705**

This work was supported by the Assistant Secretary for Conservation and Renewable Energy, Office of Renewable Technology, Division of Geothermal and Hydropower Technologies of the U.S. Department of Energy under Contract No. W-7405-ENG-48.

1945

1946

1947

1948

1949

1950

Since 1975, the Geothermal Group of the Earth Sciences Division has tested many geothermal wells. Because there was a lack of commercially available instruments suitable for geothermal well testing, a suite of instruments, especially designed for this purpose, was developed. This paper provides the engineering drawings, assembly instructions, and recommended usage for several of the instruments developed for low and moderate temperature ($< 150^{\circ}\text{C}$) hydrothermal well testing. Included in this paper are the drawings for:

- o a downhole pressure and temperature instrument
- o a multi-conductor cablehead
- o a line driver to be used with the downhole pressure and temperature instrument, and
- o a fluid-level detector.

The downhole pressure and temperature instrument uses a high resolution quartz crystal pressure transducer manufactured by Paroscientific Inc. The transducer is rated for continuous use at temperatures up to 107°C (225°F) with a maximum pressure rating of 900 psia. A thermistor is used to measure temperature. The downhole pressure and temperature instrument is run on a four-conductor armored logging cable. A specially designed multi-conductor cablehead uses an epoxy pressure seal and a grease barrier and can be fabricated to operate at temperatures up to 150°C (300°F). The cablehead provides a pressure-tight, mechanical and electrical connection between the cable and the instrument. The circuit diagram for a line driver, used to transmit the pressure data to a central data acquisition site, is also included. The fluid-level indicator was designed to eliminate the difficulties encountered

when using conventional conductivity-type water level detectors. The probe will not give erroneous readings due to thick steam layers, pump spillage, casing leaks, or nonconductive fluids.

The transducer incorporated in the pressure and temperature instrument is commercially available at relatively reasonable cost. Mention of specific brands of transducers does not imply that other types of transducers could not be substituted if the appropriate design changes were made. All of the instruments have been successfully tested under a variety of operating conditions. To ensure the successful operation of the instruments, the fabrication and assembly instructions should be followed carefully. Failure to do so could result in the destruction of the transducers and components incorporated in these instruments.

DOWNHOLE PRESSURE AND TEMPERATURE INSTRUMENT

Description

The Paroscientific Digiquartz Pressure Transducer has been used for many years in measuring precise changes in wellhead pressure, pressure differential across orifice plates, and in conjunction with "Perk" tubes and Sperry Sun downhole pressure chambers. In order to obtain precise pressure data during interference testing and accurate downhole pressure data in the production wells, the Lawrence Berkeley Laboratory Reservoir Engineering Group decided to incorporate the Paroscientific Digiquartz Pressure Transducer in a downhole pressure and temperature instrument (Figures 1 and 2).¹ The instrument can be used at the wellhead or downhole at temperatures up to 107°C (225°F).

NO.	QTY	UNIT NUMBER	DESCRIPTION
1		18B4433	HOUSING
2		18B4442	THERMISTOR GUARD
3		18B4453	HOUSING CAP
4		18B4462	THERMISTOR LEAD CONDUIT
5		18B4472	THERMISTOR WELL
6		18B4482	PRESSURE TRANSFER TUBE ASSEMBLY
7		18B4492	CONNECTOR, MODIFIED BURNDY IO PIN
REF		18B4563	CABLE HEAD
			A QUARTZ PRESSURE TRANSDUCER ASSEMBLY
			B FOAMED URETHANE SHOCK ABSORBER
			C
			D 1/8" TUBE TO 1/8" FPT ADAPTER, SWAGelok SS-200-1-2.
			E O RING, VITON, PARKER SIZE 2-144 (2 1/2 I.D. x 3/32 SECTION)
			F O RING, VITON, PARKER SIZE 2-017 (1 1/16 I.D. x 1/16 SECTION)
			G O RING, VITON, PARKER SIZE 2-177 (5/16 I.D. x 3/32 SECTION)

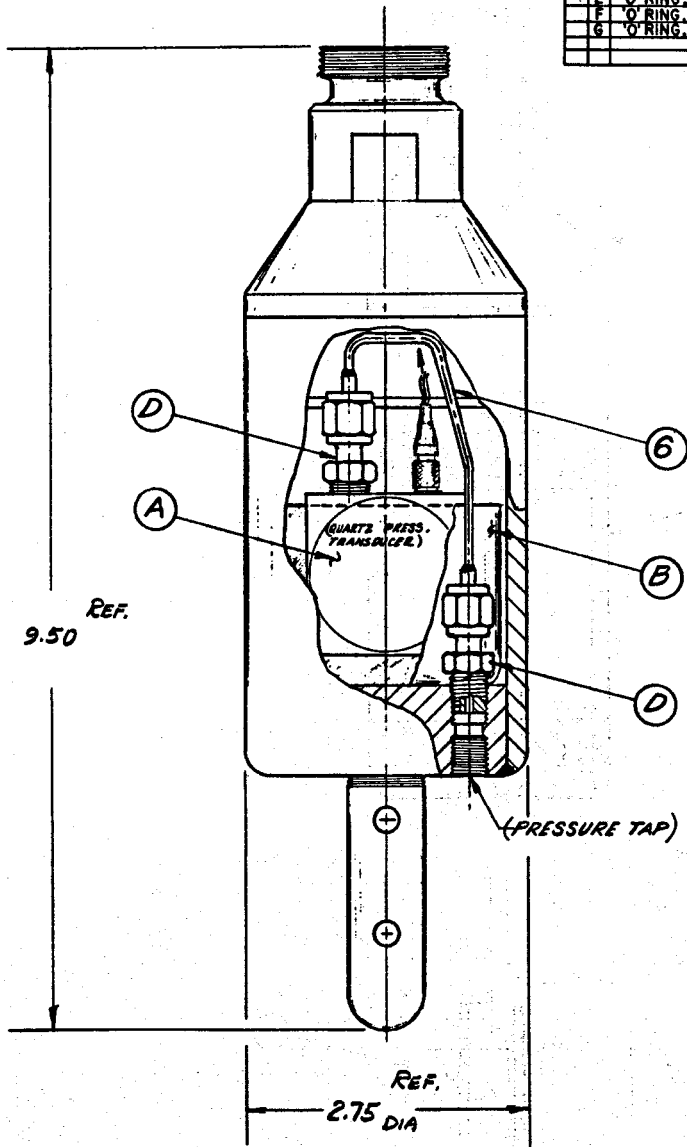

XBL 816-10102

Figure 1. Assembly drawing for the downhole pressure and temperature instrumentation.

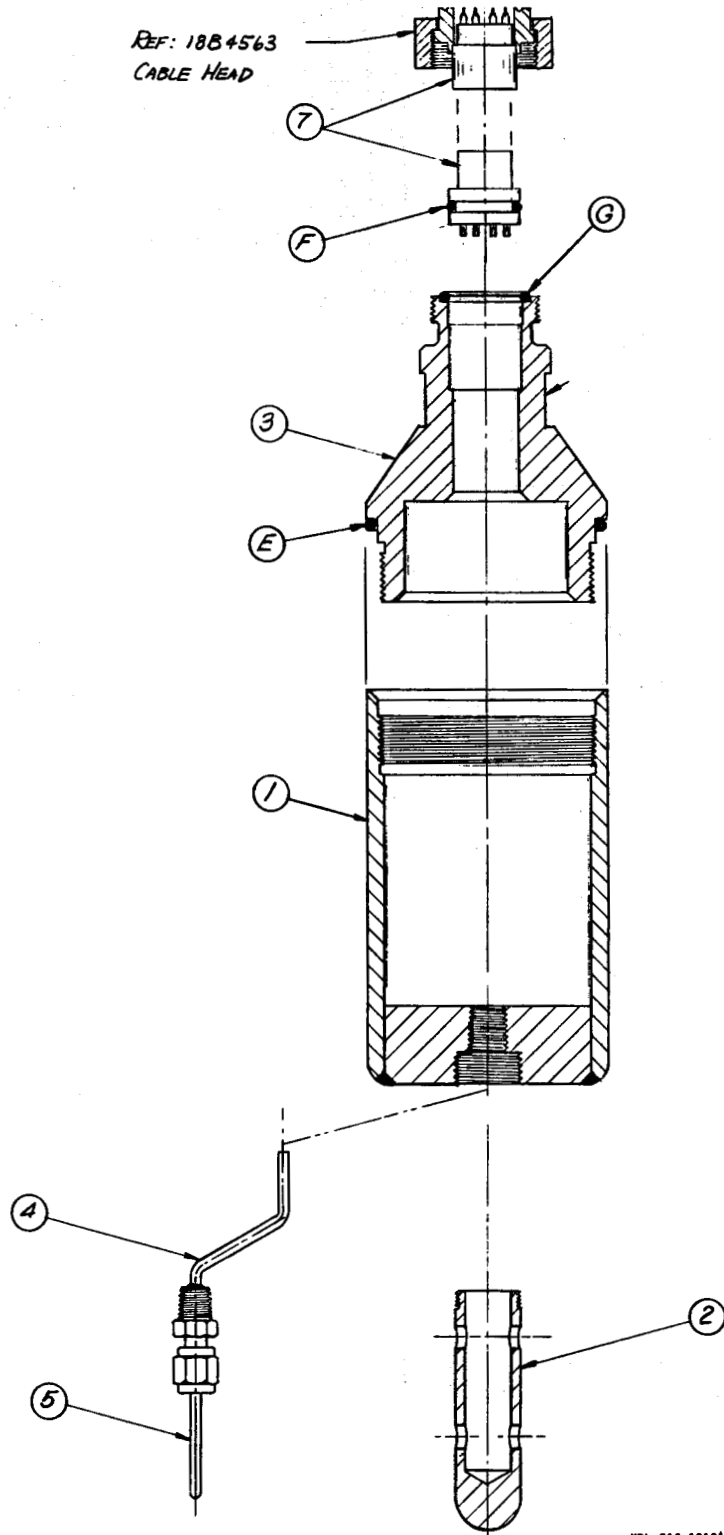

XBL 816-10101

Figure 2. Assembly drawing for the downhole pressure and temperature instrumentation.

The downhole instrument incorporates the Paroscientific 400 psia (2.8 MPa) Model 2400-A or 900 psia (6.2 MPa) Model 2900-A Paroscientific Digiquartz Pressure Transducer (Item A). The transducer is shock mounted inside the instrument package and connected to the pressure port with a stainless steel capillary tube filled with Dow Corning f.s. 1265, 300 centistoke fluid. The transducer, when interfaced with a Paroscientific Digiquartz Computer and a Hewlett Packard 5150A Thermal Printer, can display and record pressure data at intervals of one second to two hours. The combination pressure and temperature instrument is constructed from stainless steel and has an outside diameter of 2.75 inches and a length of 9.5 inches. The combination pressure and temperature instrument is suspended by an armored four-conductor cable and a specially designed multi-conductor cablehead. The temperature sensing element is a 100 K-ohm @ 25°C thermistor, protected from the well fluid by a stainless steel tube with a 0.010 inch wall thickness. The resistance of the thermistor, which is temperature dependent, is read at the surface with an ohmmeter.

The downhole pressure and temperature instrument has been successfully field tested at Klamath Falls, Oregon and Susanville, California.^{2,3}

Fabrication and Preparation for Assembly

The detail drawings (Figures 3 through 9) contain the information necessary for the complete fabrication of the downhole pressure and temperature instrument (Figure 1). The instrument is intended to be used in conjunction with the Lawrence Berkeley Laboratory cablehead. If a commercial cablehead will be used, the threaded fitting on the neck of the housing cap (Item 3) and the electrical connector (Item 7) should be changed to conform to the commercial cablehead.

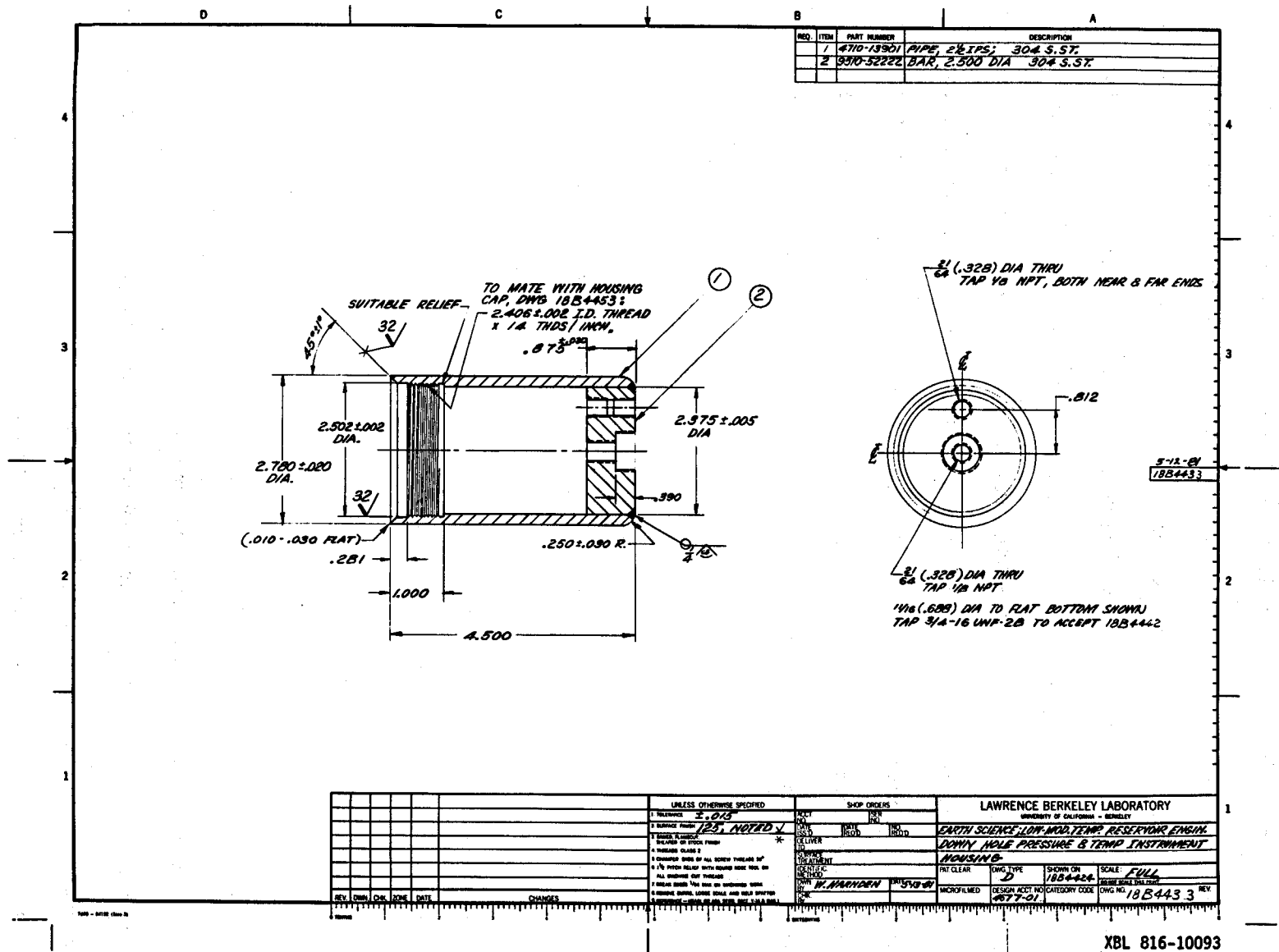
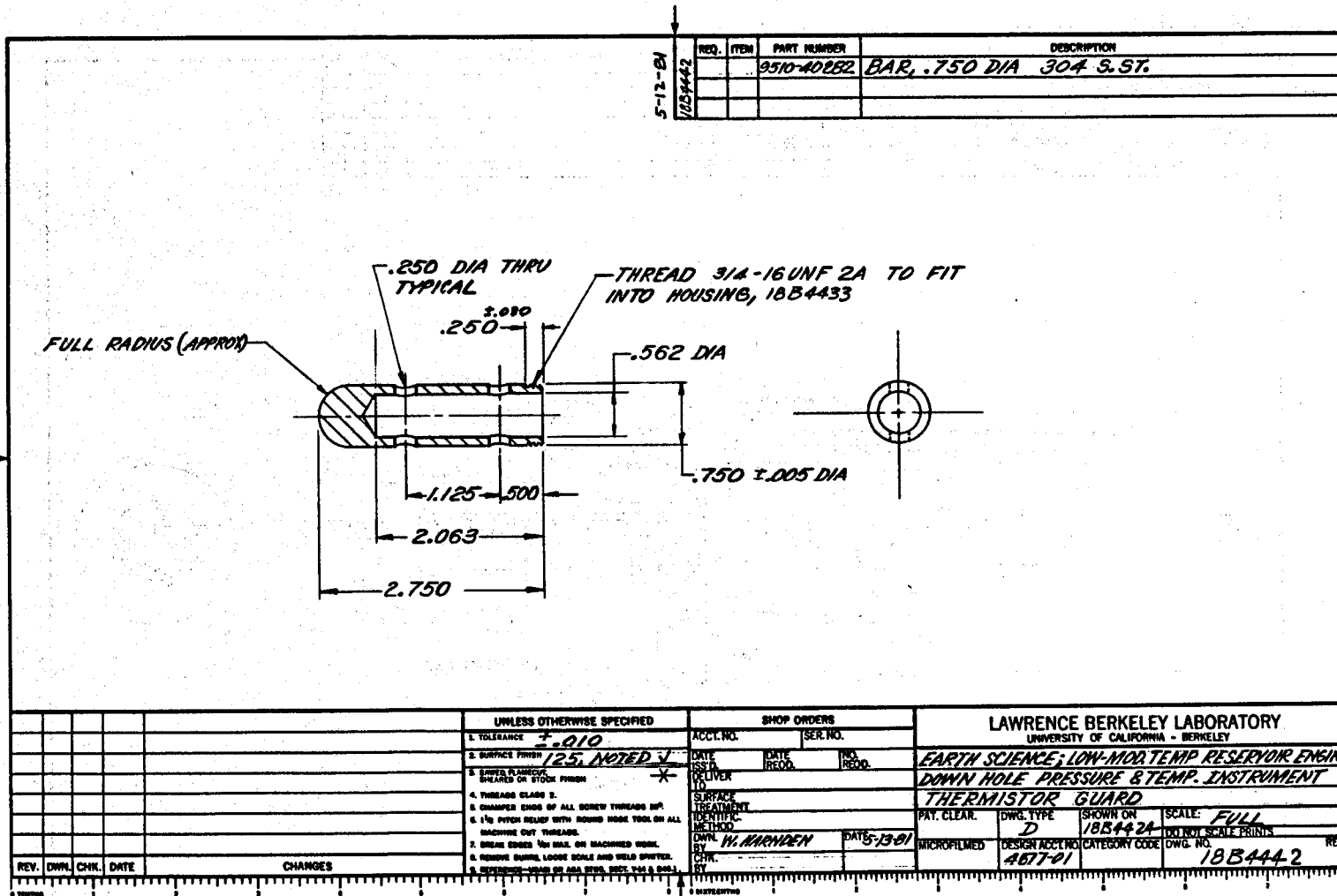

Figure 3. Detail drawing of the housing (Item 1) for the downhole pressure and temperature instrument.

XBL 816-10093



XBL 816-10087

Figure 4. Detail drawing of the thermistor guard (Item 2) for the downhole pressure and temperature instrument.

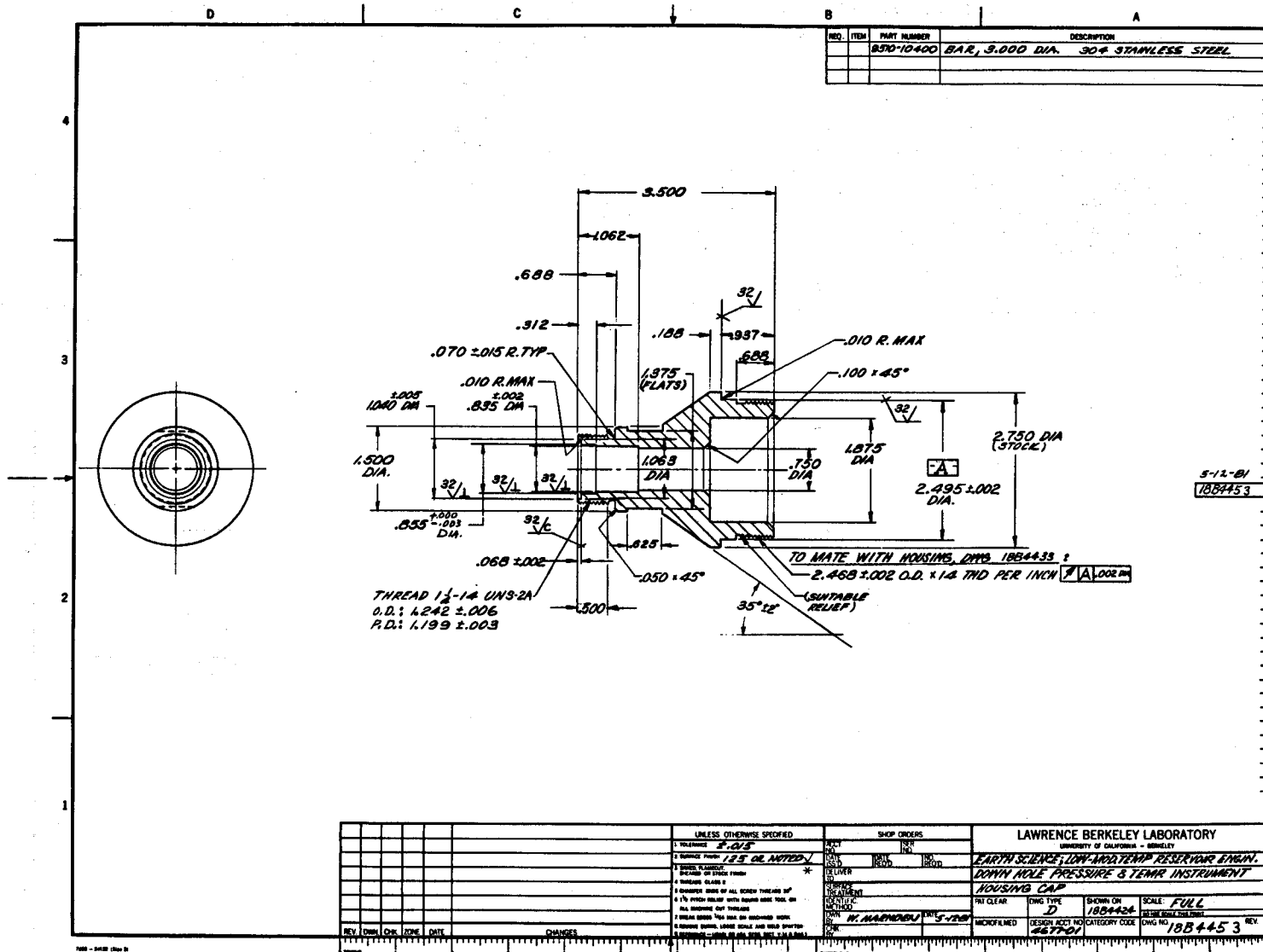

XBL 816-10094

Figure 5. Detail drawing of the housing cap (Item 3) for the downhole pressure and temperature instrument.

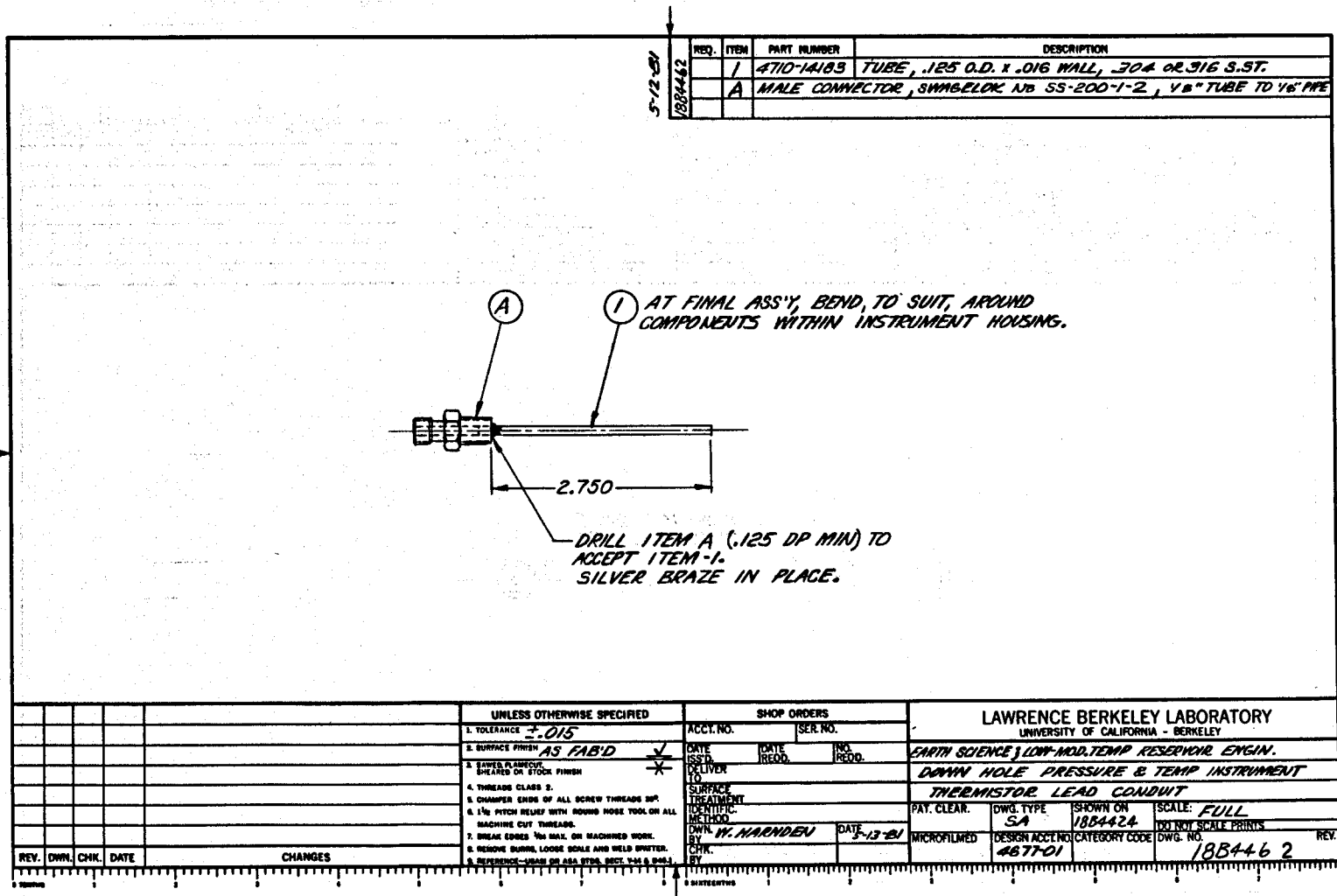

XBL 816-10088

Figure 6. Detail drawing of the thermistor lead conduit (Item 4) for the downhole pressure and temperature instrument.

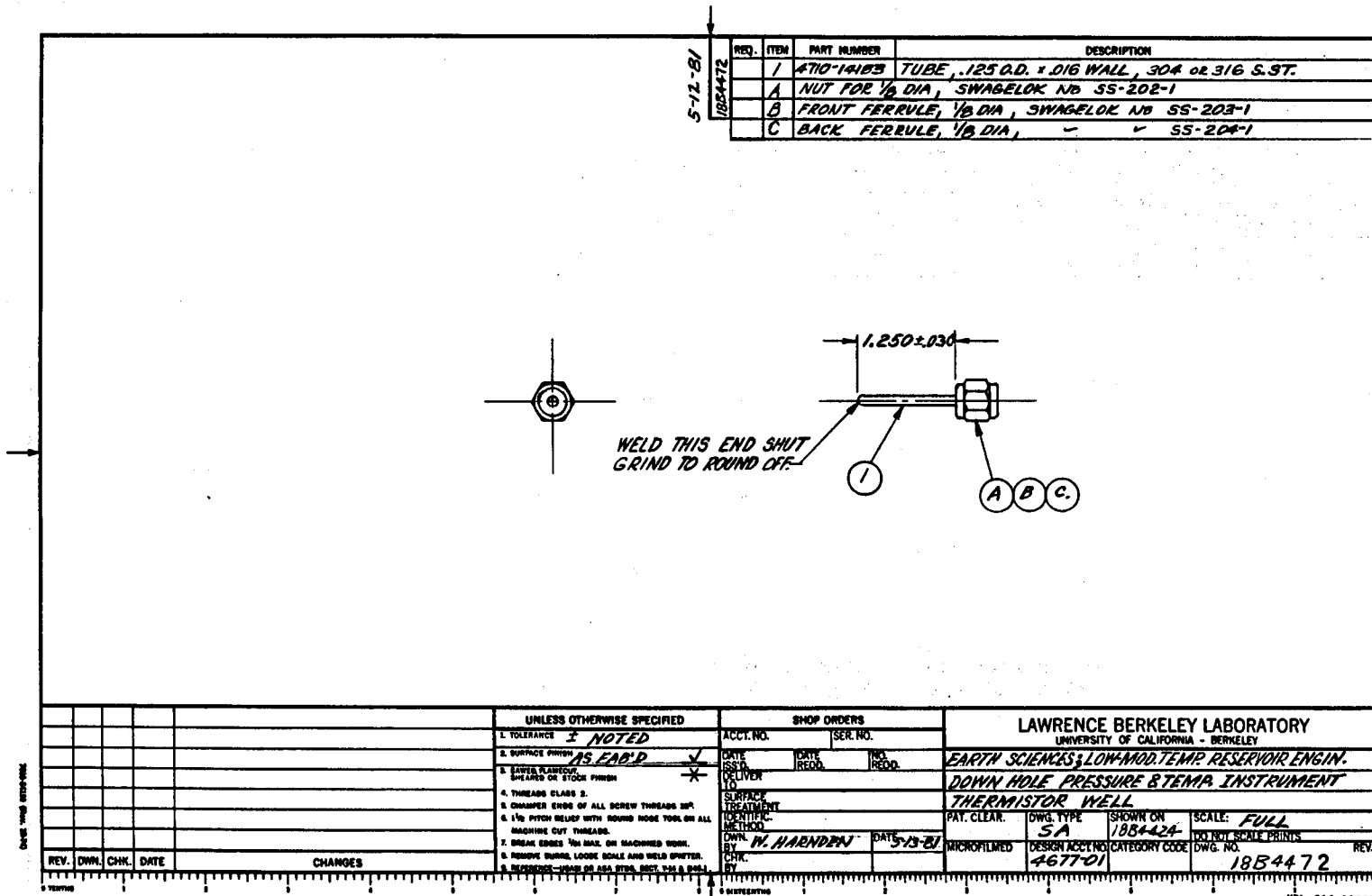

Figure 7. Detail drawing of the thermistor well (Item 5) for the downhole pressure and temperature instrument.

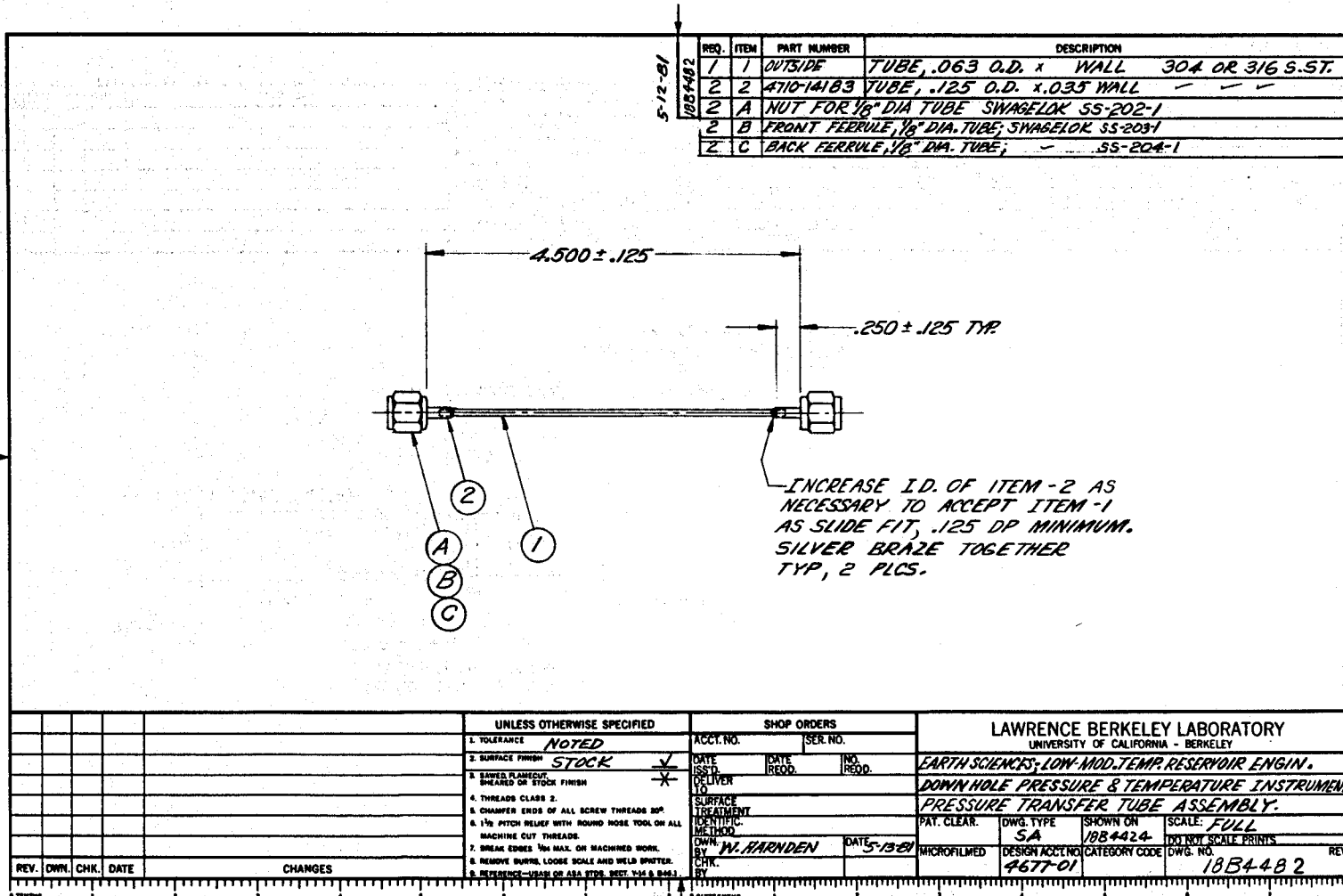

Figure 8. Detail drawing of the pressure transfer tube assembly (Item 6) for the downhole pressure and temperature instrument.

XBL 816-10090

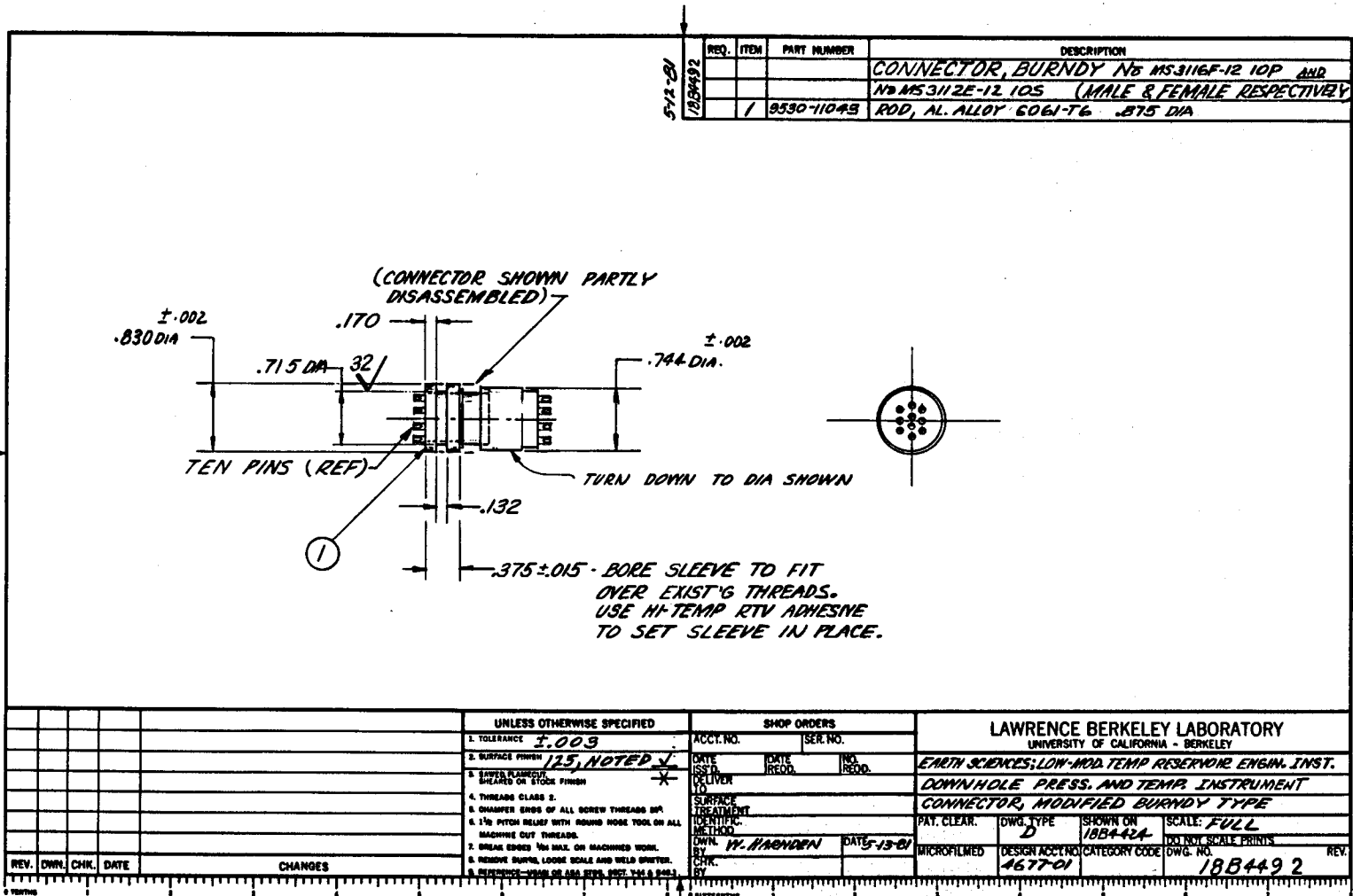

Figure 9. Detail drawing of the modified Burndy plug (Item 7) for the downhole pressure and temperature instrument.

XBL 816-10091

After all the parts needed to assemble the downhole instrument have been fabricated, cleaned, and thoroughly inspected, the housing should be assembled with the cablehead attached and pressure checked for leaks. The final assembly should be done with utmost care. Leakage of the completed downhole instrument will usually result in damage to the transducer. Manufacturer's instructions pertaining to threaded and compression fittings, use of teflon thread-tape, and O-ring preparation and installation should be followed exactly. To identify the pressure transducer that was installed, its serial number should be scribed or stamped on the outside of the housing (Item 1 in Figure 2).

Assembly Instructions for Downhole Pressure and Temperature Instruments

Refer to Figure 1 and Figure 2 for the identification of all the parts. Items identified by letter are commercially available, while items identified by number must be fabricated.

1. Wrap the pipe threads on the thermistor lead conduit (Item 4) with teflon thread sealing tape and tighten it into the housing (Item 1). Bend the stainless-steel tube extension of the thermistor lead conduit so that it is flush against the inside wall of the housing. This will facilitate the installation and replacement of the thermistor while the pressure transducer is in place.
2. Wrap the pipe threads on the compression fitting (Item D) with teflon-thread sealing tape and tighten it into the housing. Screw one end of pressure transfer tube assembly (Item 6) to the compression fitting.
3. Insert the pressure transducer (Item A) and its foamed-urethane shock absorber (Item B) into the housing.

4. Bend the pressure transfer tube assembly so that it is aligned with the compression fitting on the pressure transducer. Fill the pressure transfer tube assembly with Dow Corning f.s. 1265 fluid with the aid of a syringe. Also fill the compression fitting attached to the pressure transducer. Connect the fluid-filled pressure-transfer tube assembly to the compression fitting on the pressure transducer.
5. Insert the thermistor and its 9-inch long, 26-gauge insulated leads into the thermistor well (Item 5). Insert the thermistor leads into the compression fitting and push the leads up inside the thermistor lead conduit (Item 4). Fasten the thermistor well to the compression fitting on the thermistor lead conduit. Install the thermistor guard (Item 2).
6. Fit the housing cap (Item 3) with a silicone-greased* O-ring (Item E). Pass all of the electrical leads through the center of the housing cap. Screw the housing cap into the housing.
7. Terminate all of the electrical leads one inch above the topmost thread of the housing cap. Solder the leads to the modified Burndy male 10-pin connector (Item 7) in an electrically compatible sequence with the modified female Burndy receptacle 10-pin on the cablehead. Solder the ground lead from the pressure transducer to the braided shielding of the electrical leads from the transducer. The armor of the logging cable provides the ground path for the downhole instrument.
8. Install two silicone-greased O-rings (Item F) in the groove on the male electrical plug and push the plug into the seat with a rotating motion. This plug serves as a secondary pressure seal should the O-ring connecting the instrument to the cablehead fail.

*Dow Corning Silicone Vacuum Grease (or equivalent)

Use

The downhole pressure and temperature instrument can be attached to the previously assembled cablehead. The O-ring (Item G) should be coated with silicone grease and installed around the lip provided on the cablehead connector. Hold the instrument package stationary, mate the modified Burndy connectors and screw the nut on the cablehead securely onto the neck of the housing cap. The logging cable and the cablehead are now attached to the instrument with a mechanical, electrical, and pressure-tight connection.

The Paroscientific Digiquartz Computer can be attached to the power, signal, and ground leads of the armored logging cable. The downhole pressure and temperature instrument is now ready for use. Make certain that the pressure and temperature limits of the transducer are not exceeded. This is monitored with the pressure read-out of the computer and resistance of the thermistor as the instrument is lowered into the well. Performance specifications for the Paroscientific Digiquartz Pressure Transducer used with the downhole pressure and temperature instrument are listed in Table 1^{4,5}.

GEOHERMAL CABLEHEADDescription

A cablehead is a connector used to make a pressure tight mechanical and electrical connection between an armored logging cable and a downhole instrument. Commercially available cableheads perform properly in non-corrosive environments, but when subjected to the corrosive brines and the elevated temperatures found in geothermal wells, the brine will eventually enter the cablehead assembly. This will short the electrical conductors and corrode the steel armor. Loss of data and the eventual loss of the downhole instrument could result.

Table 1. Performance Specifications for the Paroscientific 400 psia and 900 psia Digiquartz Transducers (from Paros, J.M.)

Repeatability	0.005% full scale
Hysteresis	0.005% full scale
Temperature null shift*	0.0004% full scale/°F 0.0007% full scale/°C
Temperature span shift*	0.0026% of reading/°F 0.0049% of reading/°C
Overpressure	1.2 times full scale
Operational temperature range	-65 to +225°F -54 to +107°C

*Temperature null shift and temperature span shift can be corrected by using the appropriate constants supplied by Paroscientific, Inc.

The Geothermal Group at Lawrence Berkeley Laboratory has designed an inexpensive multi-conductor cablehead (Figure 10). The body is machined from stainless steel and has a length of 9 inches and a 1.5 inch diameter. It has an overshoot provision for retrieval should the cablehead and attached instrument be lost downhole. The mechanical strength of the fastening mechanism is obtained by forcing a brass cone against the unbraided cable strands inside an internally-tapered sleeve.

The cablehead incorporates an epoxy* pressure seal. The epoxy used has excellent corrosion, chemical, and solvent resistant properties. The epoxy seal is formed by pouring the epoxy mix around the electrical conductors inside the tapered, conductor seal cavity. Should it become necessary, the epoxy seal can be removed with an electric drill. The cable can then be re-headed and a new epoxy seal poured in place. This can be carried out even under field conditions. Using an epoxy seal has several advantages over conventional cablehead seals. It adapts itself to single conductor as well as multi-conductor cable. It does away with the tedious job of installing rubber boots and teflon-tape wrapped conductor seals. It also has a high operating temperature limit. Epoxy with an operating temperature of up to 600°F (315°C) is available.

The cablehead also incorporates a grease barrier. A high-temperature grease is pumped through a removable zerk fitting to fill all the voids within the cablehead assembly. This prevents the adverse effect of the brine on the support-strand connections of the cable, thus reducing the frequency of reheading the cable due to corrosion of cable inside the cablehead assembly.

*Shell 826 Epoxy (or equivalent) for low-to moderate temperature application

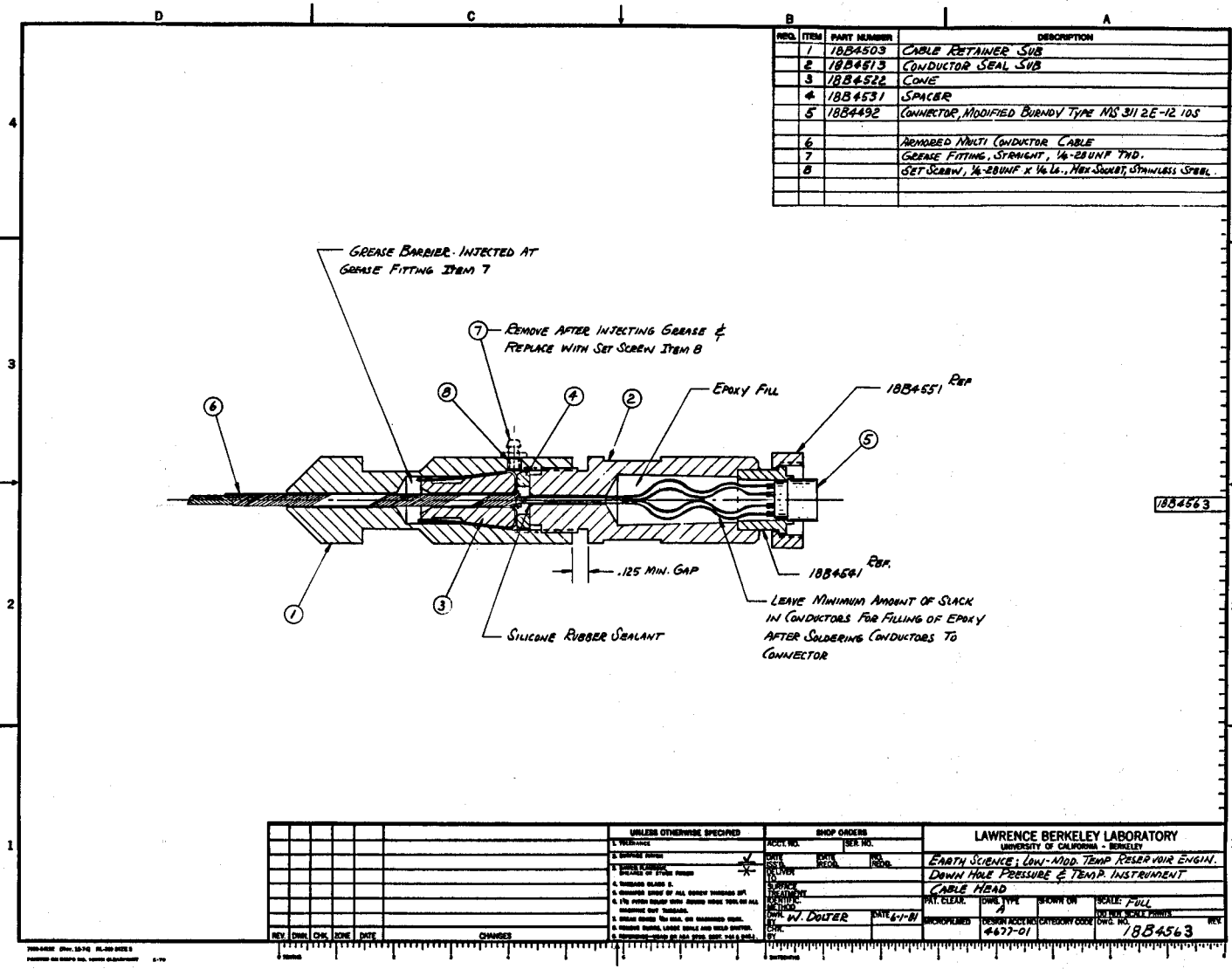

XBL 816-10097

Figure 10. Assembly drawing of the geothermal cablehead.

The mechanical connection of cablehead to downhole instrument is made with a threaded union type fastener incorporating an O-ring seal, and multi-conductor electrical connector.

Fabrication and Preparation for Assembly

All the parts may be fabricated from the detail drawings (Figures 11 to 16). The fabricated parts should be carefully inspected to make certain that all mating parts fit properly. The braze joint on the conductor-seal subassembly (Item 2) should be checked for mechanical strength and pressure tightness. All parts should be thoroughly degreased with a solvent, and the epoxy cavity for the conductor-seal subassembly should be sand-blasted to ensure maximum adhesion of the epoxy. The manufacturer's directions for mixing and curing the epoxy should be followed. The detail drawing for the modified female Burndy type connector is shown on Figure 9 (Item 7).

Assembly of the Cablehead

Refer to Figure 10 for identification of all the parts which are needed for the assembly of the cablehead.

- 1) Attach the logging cable to the cable retainer sub (Item 1) using the same general procedure as used for heading up the Gearhart-Owen single-conductor cablehead. Normal precautions should be taken to insure that the armor strands do not cross each other around the cone (Item 3).
- 2) Remove the surface gloss on the conductor insulation of the logging cable with steel wool to ensure good adhesion to the epoxy. Degrease the conductors.
- 3) Install the spacer (Item 4) and place a small amount of silicone-rubber* sealant at the location inside the spacer as shown in the assembly drawing.

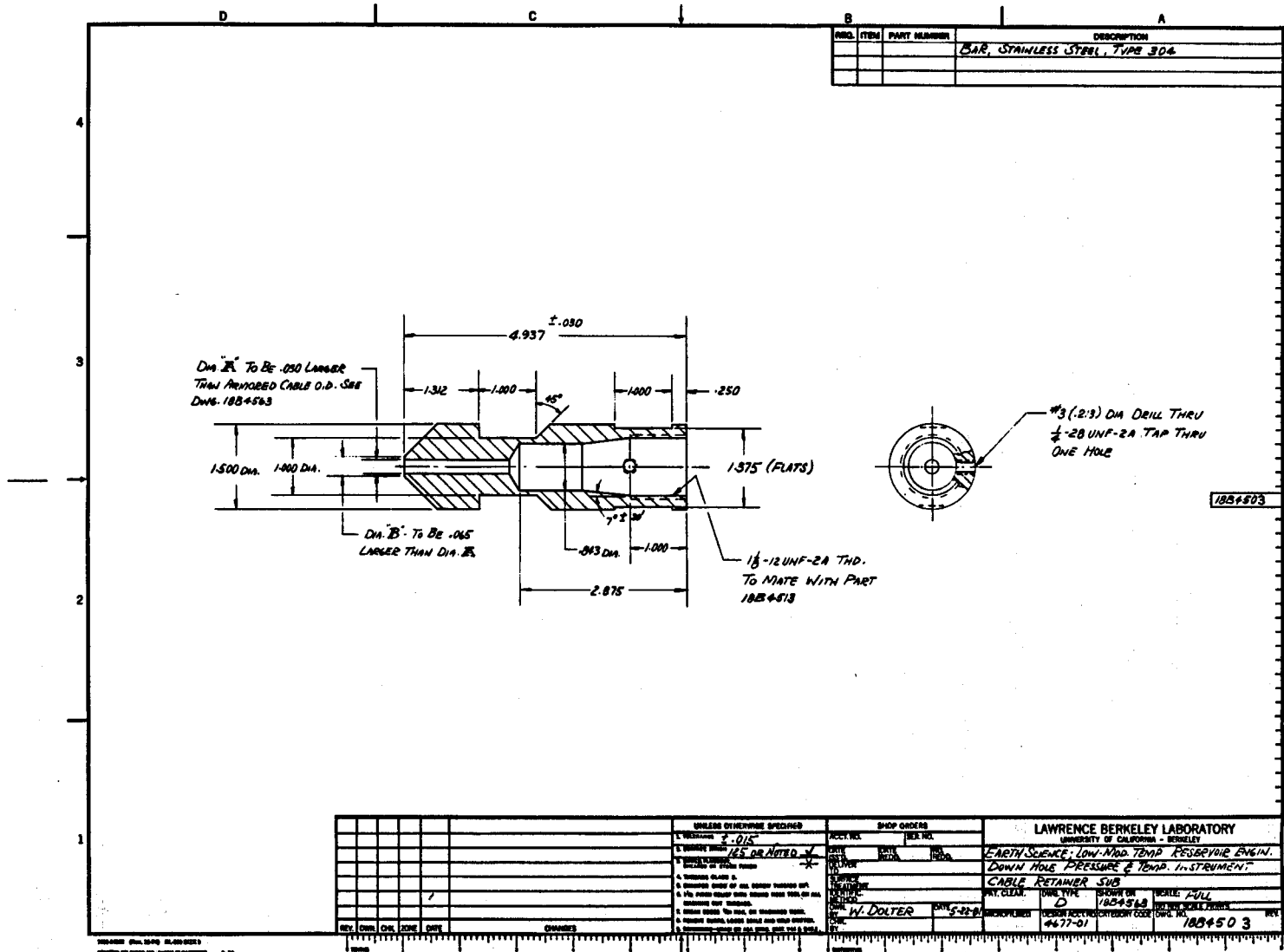

Figure 11. Detail drawing of the cable retainer sub (Item 1) of the geothermal cablehead.

XBL 816-10096

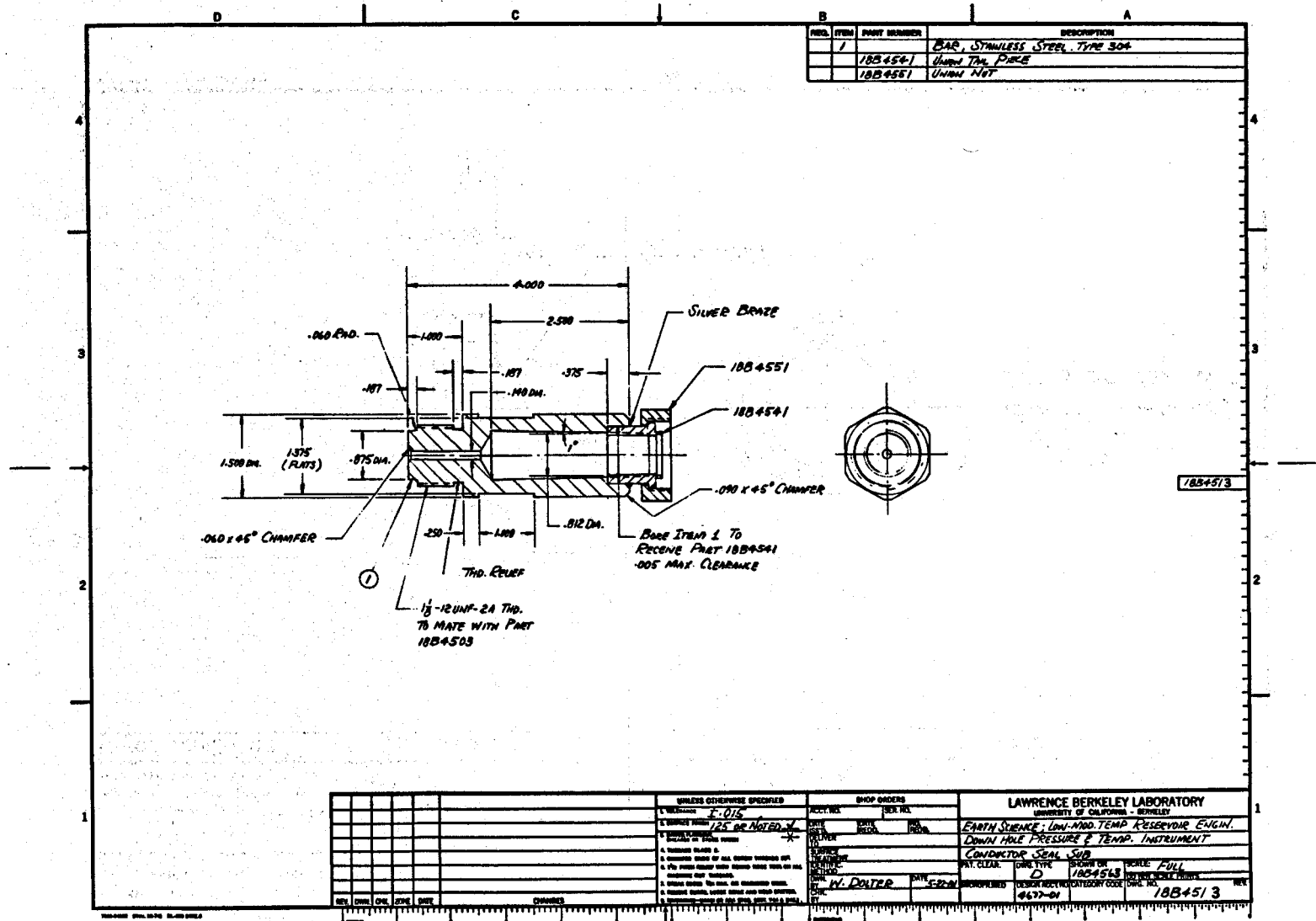

Figure 12. Detail drawing of the conductor seal sub (Item 2) of the geothermal cablehead.

UNLESS OTHERWISE NOTED			SHOP ORDERS			PATENT CL'R	DWG. TYPE	SHOWN ON	DWG. NO.	REV.	
X± —	XX± —	XXX± —	ACCT. NO.	SER. NO.			D	18B4513	18B455 1		
Angles ± —	Finish 125 ✓		DATE ISS'D.	DATE REQ'D.	NO. REQ'D.	MICROFILMED	DES. ACCT. NO.	CATEGORY	SCALE (Do not scale prints)		
Threads are class 2. Chamfer ends of all screw threads 30 Cut 1.5 pitch thr'd relief with round nose tool on machine cut threads. Break edges .016 max. on machined work. Remove burrs weld spatter & loose scale. References: ANSI Y14.5 & B46.1.			DEL. TO	LAWRENCE BERKELEY LABORATORY U.C. BERKELEY							
			SURFACE TREATMENT	EARTH SCIENCE; LOW-MOD. TEMP. RESERVOIR ENGIN.							
			IDENTIF. METHOD	DOWN HOLE PRESSURE & TEMP. INSTRUMENT							
			DWN BY W. DALTER	DATE 5-28-81	UNION NUT						
			CHK BY	MATERIAL UNION NUT - FROM A UNION PIPE FITTING.							
REV.	DWN	CHK	DATE	CHANGES			1/2 IPS STAINLESS STEEL, LBL STOCK #4730-15495				

7600-54168 (REV. 4-80) RL-230-1

XBL 816-10099

Figure 13. Detail drawing of the union nut (part of Item 2) of the geothermal cablehead.

UNLESS OTHERWISE NOTED			SHOP ORDERS			PATENT CL'R	DWG. TYPE	SHOWN ON	DWG. NO	REV.
X±	XX±	XXX±.005	ACCT. NO.	SER. NO.			D	18B4513	18B454	1
Angles±	Finish	125 ✓	DATE ISS'D.	DATE REQ'D.	NO. REQ'D.	MICROFILMED	DES. ACCT. NO	CATEGORY	SCALE (Do not scale prints)	
Threads are class 2. Chamfer ends of all screw threads 30 Cut 1.5 pitch thr'd relief with round nose tool on machine cut threads. Break edges .016 max. on machined work. Remove burrs weld spatter & loose scale. References: ANSI Y14.5 & B46.1.			DEL. TO	LAWRENCE BERKELEY LABORATORY U.C. BERKELEY						
			SURFACE TREATMENT	EARTH SCIENCE; LOW-MOD. TEMP. RESERVOIR ENGIN.						
			IDENTIF. METHOD	DOWN HOLE PRESSURE & TEMP. INSTRUMENT						
			D'WN BY	W. DOLTER	DATE	5-22-81	UNION TAIL PIECE			
			CHK BY		MATERIAL MALE TAIL PIECE FROM A UNION PIPE FITTING.					
REV.	DWN	CHK	DATE	CHANGES			1/2 IPS STAINLESS STEEL, LBL STOCK #4730-15495			

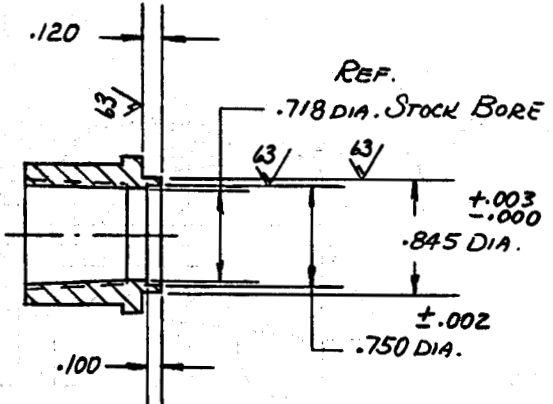

7000-24148 (REV. 4-80) BL-530-1

XBL 816-10100

Figure 14. Detail drawing of the union tail piece (part of Item 2) of the geothermal cablehead.

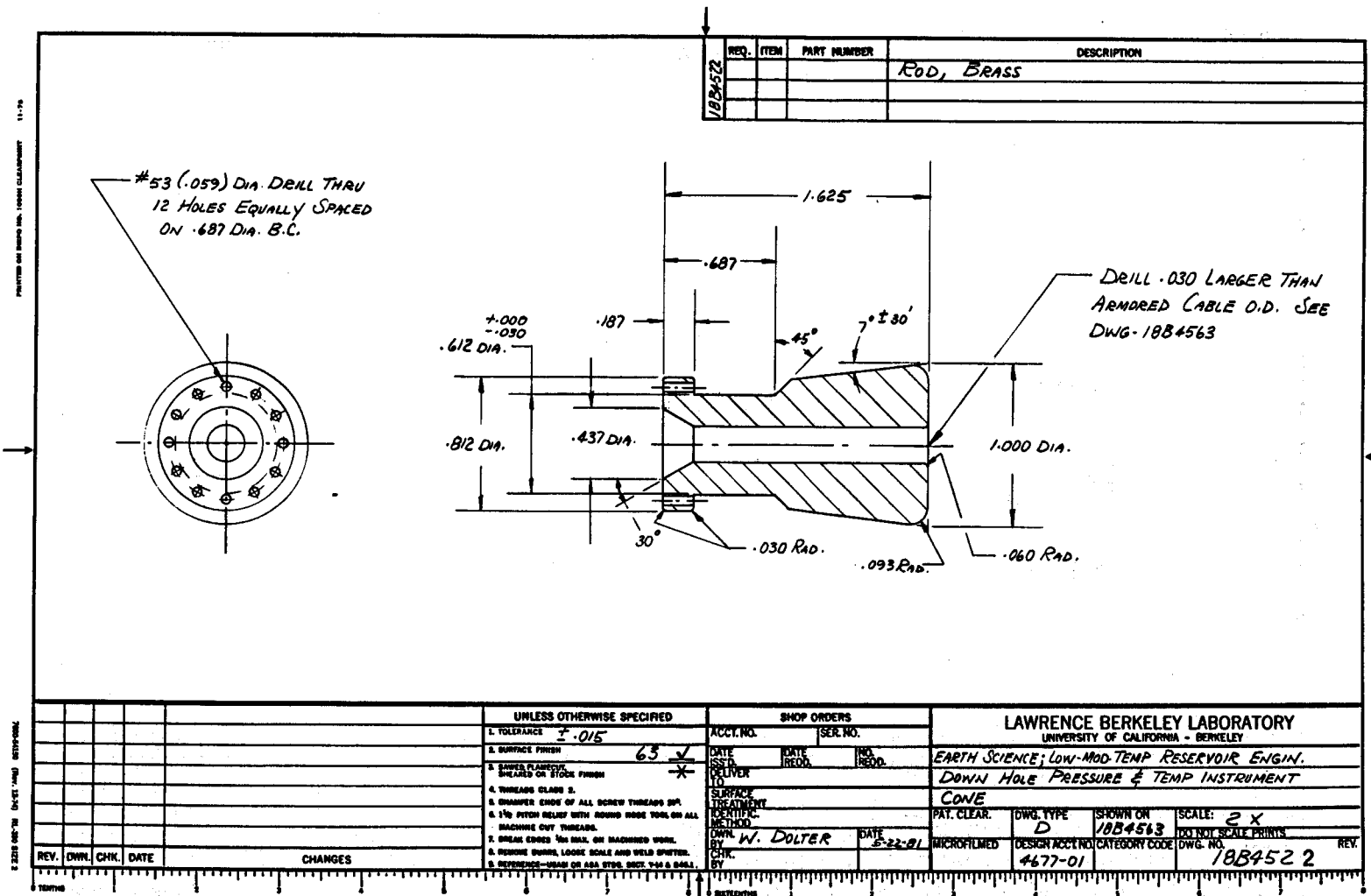
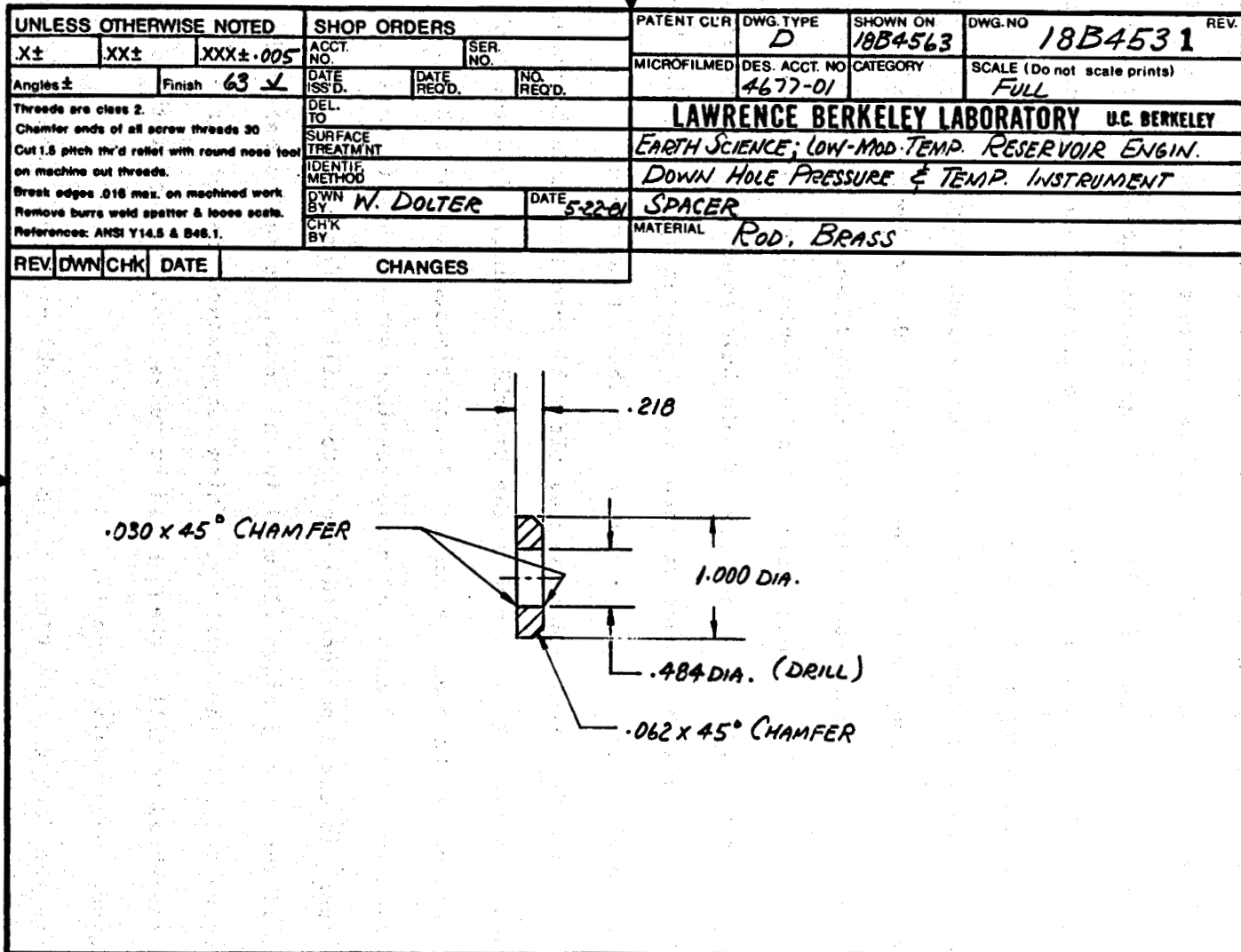

Figure 15. Detail drawing of the cone (Item 3) of the geothermal cablehead.

XBL 816-10092



7000-26148 (REV. 4-90) BL-230-1

XBL 816-10098

Figure 16. Detail drawing of the spacer (Item 4) for the geothermal cablehead.

- 4) Screw the conductor-seal subassembly (Item 2) into the cable-retainer subassembly (Item 1). Make sure that the insulated strands are pulled through the center of the conductor-seal subassembly (Item 2) as shown in the assembly drawing. If a minimum gap between the two subs as shown in Figure 10 cannot be maintained, a second spacer (Item 4) should be installed. The two parts should be screwed together securely and checked to ensure that a gap is maintained.
- 5) Terminate the conductor leads to leave just enough length to solder them to the modified female Burndy plug (Item 5). Use solder that has the appropriate temperature rating for the intended use.
- 6) Fill the cavity in the conductor-seal subassembly (Item 2) with epoxy using a plastic syringe. The epoxy should have good adhesive properties to both metal and the conductor insulation. The epoxy should also have the appropriate operating temperature for the intended use.
- 7) Push the modified female Burndy plug (Item 5) into the conductor-seal subassembly (Item 2) as shown in the assembly drawing. Hold the plug in place until the epoxy is cured. Do not tighten the conductor-seal subassembly (Item 2) into the cable-retainer subassembly (Item 1) after the epoxy is cured because the conductors will be damaged.
- 8) Install the zerk fittings (Item 7) in the conductor-seal subassembly (Item 2) and fill the cavity with high temperature silicone grease^{**}. The cablehead is filled when grease extrudes from the top of the cable-retainer subassembly (Item 1).
- 9) Remove the zerk fitting (Item 7) from the cable-retainer subassembly (Item 1) and replace it with a set screw (Item 8).

*Dow Corning Silicone Rubber Sealant (or equivalent)

**Dow Corning Silicone Vacuum Grease (or equivalent)

Use

This cablehead can be used in conjunction with any downhole instrument requiring a single or multi-conductor armored cable, as long as Item 1 and Item 3 are machined to fit the cable being used. At the Lawrence Berkeley Laboratory this cablehead is used to connect a four-conductor armored cable to a downhole pressure and temperature instrument.

Before each use the cablehead should be regreased by following Step 8 of the assembly procedure. This will protect the internal parts of the cablehead and unbraided armored strands of cable from the corrosive properties of the brine.

An O-ring seal is used to prevent fluid from entering the cablehead and downhole instrument. The O-ring (Figure 2, Item G) should be coated with silicone grease and slipped over the lip provided on the conductor-seal subassembly. To connect the cablehead to the instrument, insert the female electrical connector on the cablehead into the male connector on the instrument. Without rotating the instrument or the cablehead, tighten the nut on the cablehead to the instrument. Make sure that the connection is made securely. The armored cable, cablehead and instrument are now joined with a pressure tight mechanical and electrical connection.

LINE DRIVERDescription

When using Paroscientific Digiquartz Pressure Transducers for simultaneous interference test measurements, it is desirable to transmit the data from the measurement site to a central data-acquisition location. This

allows for accurate clock synchronization, observation of all instrument functions, and rapid fault detection and isolation. Because the pressure transducer has a limited transmission range, it is necessary to amplify the signal before it is transmitted. The Field Systems Group at Lawrence Berkeley Laboratory designed and built a line driver for use with the Paroscientific Digiquartz Pressure Transducer. The signal from the transducer is detected, amplified, and transmitted by the line driver circuit.

The line-driver circuitry is housed in a small instrument enclosure (Figure 17). The line driver and two 12-volt automotive batteries are placed at the well where the pressure transducer is being used and connected to it with a three-conductor lead. An inexpensive two-conductor wire is used to transmit the signal from the line driver to the central data acquisition location. The signal from the line driver can be transmitted for a distance of four miles.

Circuitry

Power is supplied to the line driver and Paroscientific transducer by two 12-volt automotive batteries. The line driver circuit (Figure 18) contains a pair of diodes to ensure that the power is supplied from the battery with the highest charge and also provides reverse voltage protection. Over-voltage and transient protection for the pressure transducer and line driver electronics are provided by a fuse and zener diodes. Voltage is supplied to the integrated circuits by an LM309 (or equivalent) voltage regulator.

The signal from the transducer is detected and amplified by a SE 555 (or equivalent) timer IC. The timer IC is not used for its typical application as an oscillator or timer. Instead it is incorporated into an amplifier

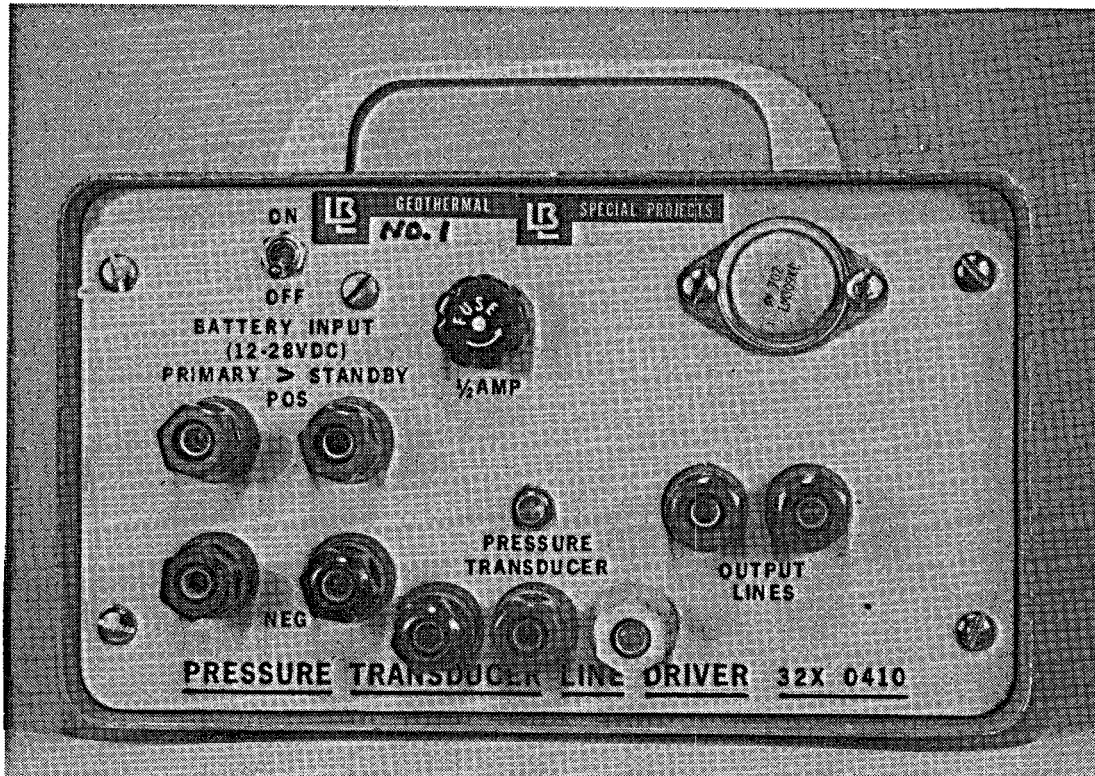

XBB 816-5545

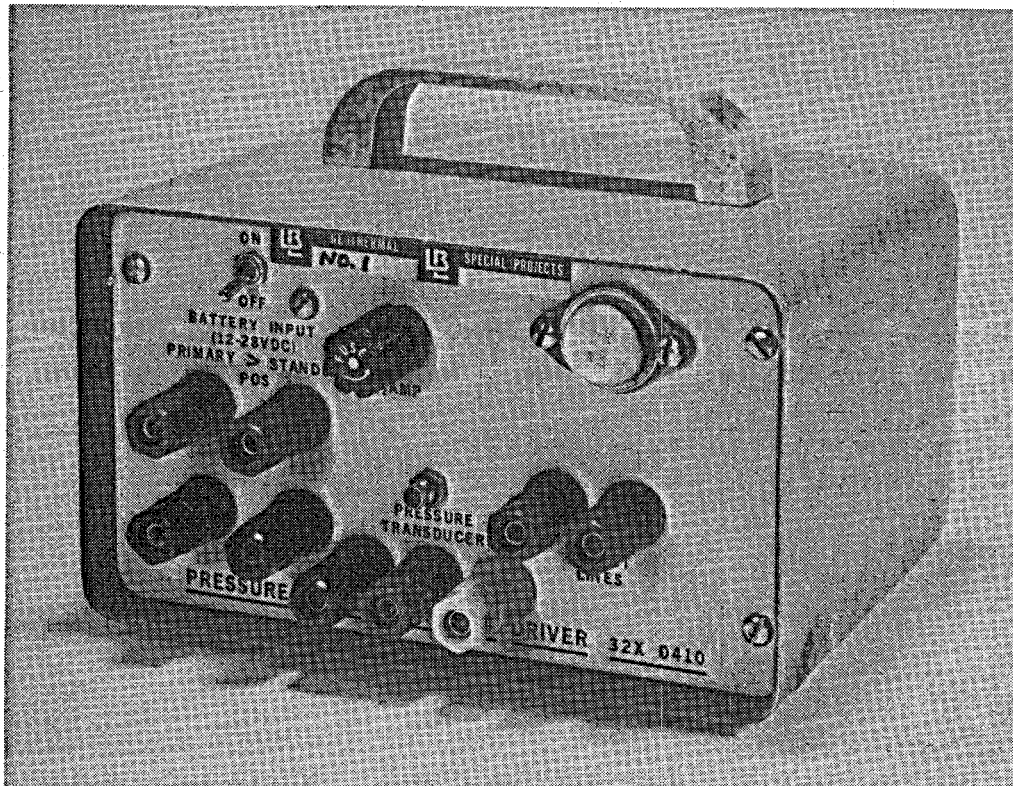

XBB 816-5546

Figure 17. The instrument housing for the line driver.

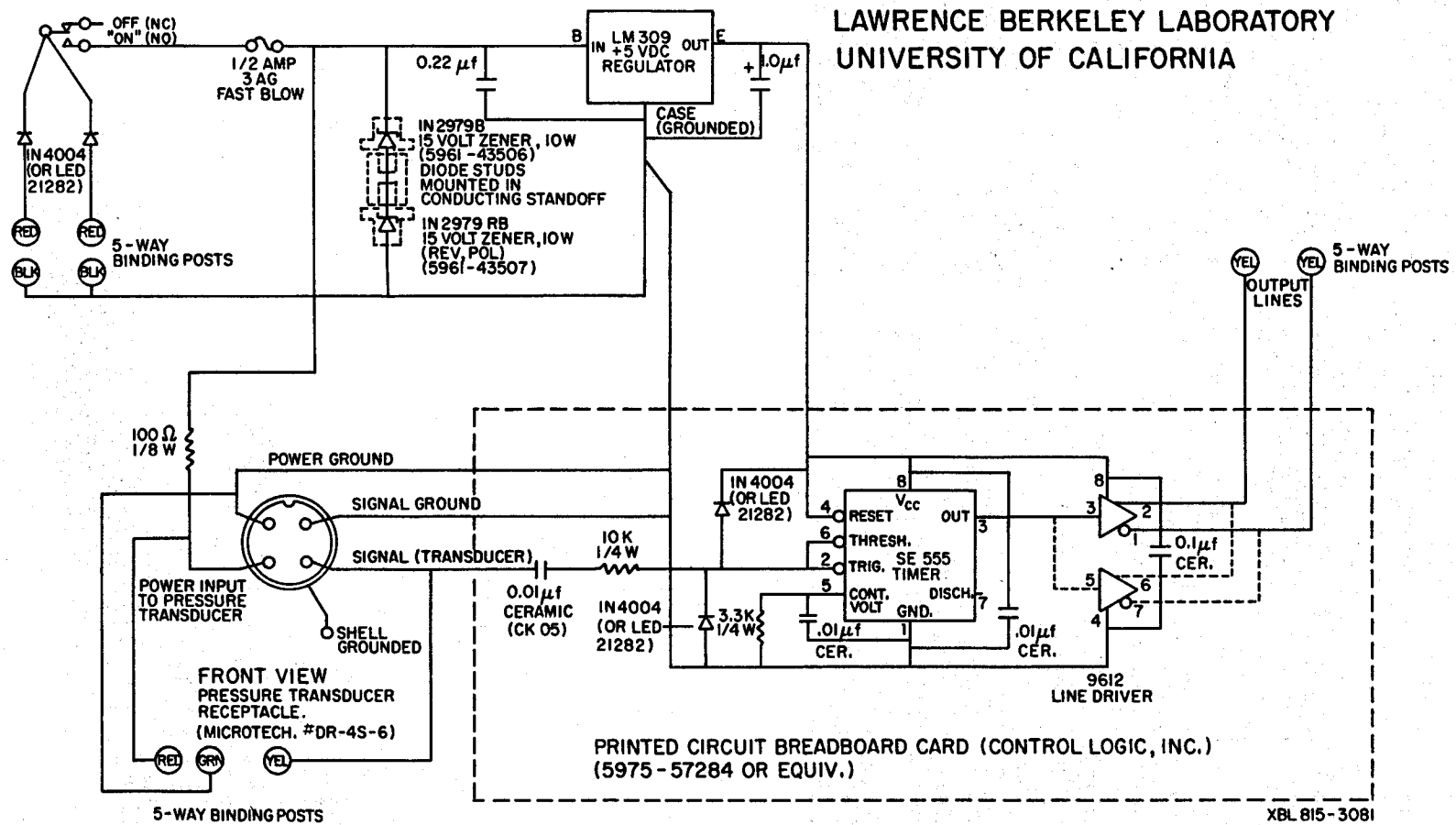

Figure 18. Circuit diagram for the line driver.

input circuit which is designed to simulate the same impedance seen by the output of the pressure transducer when it is connected directly to the Paroscientific Digiquartz Transducer. The circuit configuration, which is shown in Figure 18, provides relatively high input impedance and threshold detection with hysteresis for noise immunity.

The signal is transmitted from the line driver to the central data acquisition system with a 9612 (or equivalent) differential line driver manufactured by Fairchild Semiconductor. It provides balanced drive for the signal transmission over low-cost, twisted-pair military surplus field telephone wire. The dashed line in Figure 18 shows an emergency wiring configuration provided in case of first driver failure without total destruction of the IC. The output of the line driver is a square wave.

Use

The line driver in its metal housing is placed close to the well instrumented by a Paroscientific Pressure Transducer. Two 12-volt automotive batteries are connected to the electrical connectors on the line driver (Figure 17). The batteries provide power for the pressure transducer and line driver. One battery at a time can be replaced without interruption of data. The power, signal, and ground leads from the pressure transducer are also connected to the electrical fittings on the line driver (Figure 17). Inexpensive two conductor wire connects the line driver to the input and ground receptacles of the Paroscientific Computer.

WATER LEVEL INDICATOR

Description

Fluid level indicators, as used in well testing, are portable instruments used to detect the water level in the wellbore. The most commonly used probe is a conductivity-type gauge. The weighted probe attached to a two conductor cable is run down a well. When the probe contacts the water an electrical circuit is completed and the current flow is detected at the surface. When used in cold water wells, such a probe performs adequately; but for hot wells it is often unreliable. Because a conductivity-type gauge relies solely on the conductivity of the downhole fluid to complete the electrical circuit, erroneous readings may result due to heavy steam layers, spill over from pumps, and casing leaks. Nonconductive fluids floating on the water surface, such as liquid paraffin or oil, can also cause erroneous readings.

We have found that by replacing a conventional conductivity-type probe with a GEMS model LS-1700 liquid-level switch, these problems can be avoided. In the GEMS unit a magnet-equipped float rises with the fluid level and closes a reed switch encased in the unit's central stem. An electrical circuit is completed and the current is detected at the surface.

Fabrication

The assembly and fabrication drawings are as shown in Figure 19. The GEMS liquid-level switch (model LS-1700) is inexpensive and readily available. The parts surrounding the unit, Parts 3 and 4 (see assembly drawing) should be made of a nonmagnetic material to avoid interference with the operation of the probe.

Assembly

Refer to Figure 19 for identification of all the parts mentioned in this section.

- 1) Insert the GEMS liquid level switch into the fabricated housing (Items 3 and 4) letting the leads and threaded portion of the GEMS unit protrude through the hole (Item 4). Slip the hose fitting (Item 2) over the leads.
- 2) Fill the hose fitting with silicone rubber sealant and screw it securely to the GEMS unit.
- 3) Insert the two-conductor cable with the conductivity type probe removed through a one-foot section of appropriately-sized heat shrink tubing.
- 4) Solder the leads from the GEMS Unit to the leads of the two-conductor cable approximately two inches beyond the end of the hose fitting. Cover the solder joint, the cable, and the end of the hose fitting with silicone rubber sealant.
- 5) Slip the shrink tubing over the cable solder joint and hose fitting. Heat the shrink tubing until it fits snugly on the cable. Do not use the probe until the silicone rubber sealant has set.
- 6) Add split-type lead weights to the cable to facilitate running the probe down a well.

Use

The unit described here can be substituted on the end of a conventional conductivity-type water-level indicator. When the fluid level is reached, an electrical circuit is completed and will be detected on the surface read-out provided with the water level indicator. If an entire water level indicator is to be constructed, a suitable substitute for the surface readout is an ohmmeter.

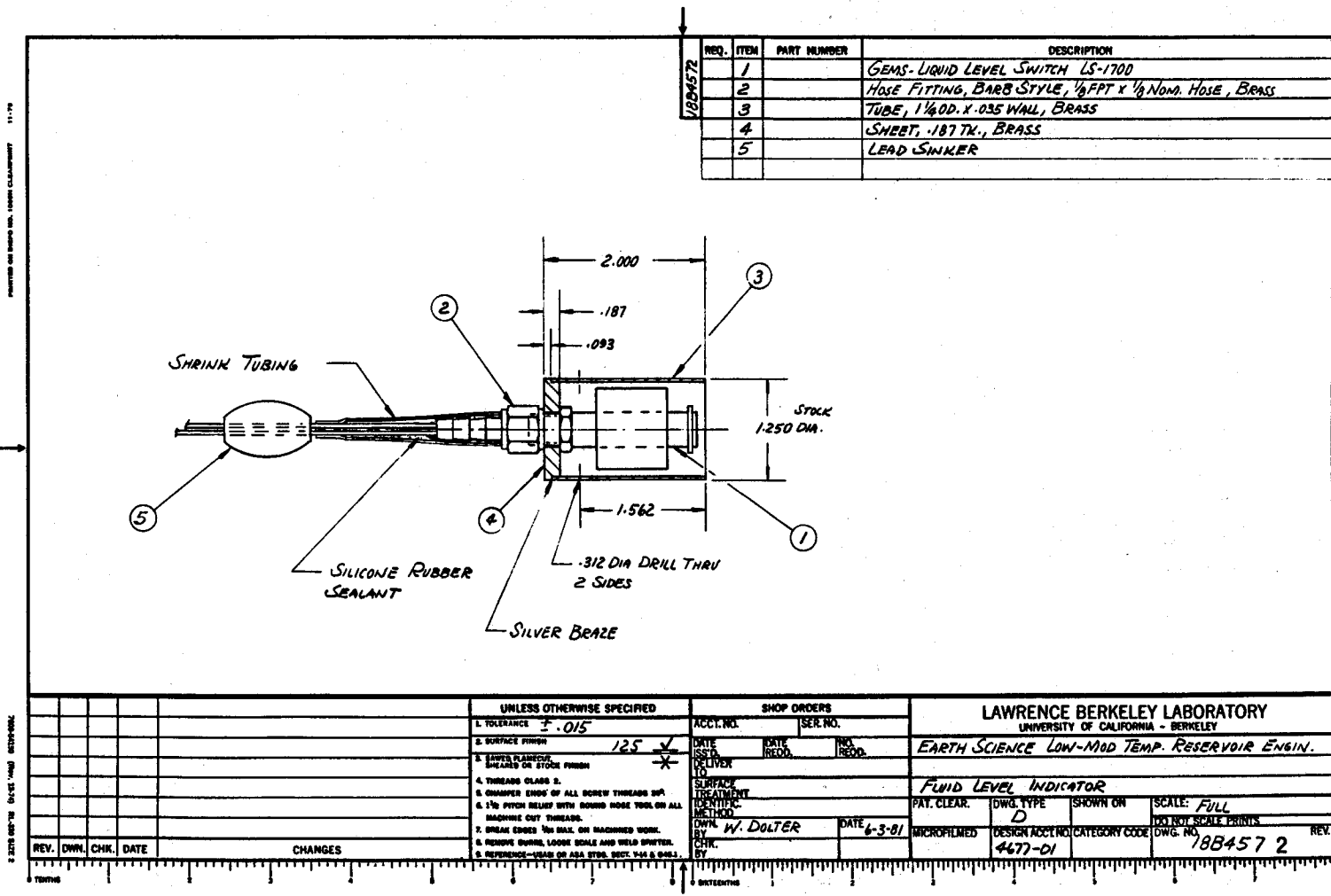

Figure 19. Assembly drawing of the fluid level indicator.

XBL 816-10189

ACKNOWLEDGMENTS

We would like to thank Mr. Eugene Binnall of the Field Systems Group for his contributions to the development of the line driver. We also want to express our appreciation to Mr. Ron Schroeder for supporting this work and for helping provide us with the opportunity to test the instrumentation in the field. We also acknowledge the assistance of Mr. Donald Lippert and Mr. Robert Davis in field testing all of the instruments in Klamath Falls, Oregon, Cerro Prieto, Mexico, East Mesa, California, and Susanville, California.

This work was supported by the Assistant Secretary for Conservation and Renewable Energy, Office of Renewable Technology, Division of Geothermal and Hydropower Technologies of the U.S. Department of Energy under Contract No. W-7405-ENG-48.

REFERENCES

1. S.M. Benson, "A Downhole Pressure/Temperature Probe for Low-Temperature Geothermal Applications," Earth Sciences Division Annual Report 1980, Lawrence Berkeley Laboratory Report LBL-12100, July 1981.
2. S.M. Benson, C.B. Goranson, J. Noble, R. Schroeder, D. Corrigan, and H. Wollenberg, "Evaluation of the Susanville, California Geothermal Resource," Lawrence Berkeley Laboratory Report LBL-11187, 1981.
3. S.M. Benson, C.B. Goranson, and R.C. Schroeder, "Evaluation of City Well 1, Klamath Falls, Oregon," Lawrence Berkeley Laboratory Report LBL-10848, 1980.
4. J.M. Paros, "Digital Pressure Transducer," Measurements and Data, Vol. 10, No. 2, March-April 1976.
5. R.B. Wearn and N.G. Larson, "The Paroscientific Pressure Transducer: Measurements of Its Sensitivities and Drift," University of Washington Applied Physics Laboratory Report APL-UW 8011, August 1980.