

SEP 11 1985



# Lawrence Berkeley Laboratory

UNIVERSITY OF CALIFORNIA

## Accelerator & Fusion Research Division

LBL--18963

DE85 017642

Presented at the 1985 Particle Accelerator  
Conference, TRIUMF, Vancouver, B.C., Canada,  
May 13-16, 1985

THE METAL VAPOR VACUUM ARC (MEVVA)  
HIGH CURRENT ION SOURCE

I.G. Brown

May 1985

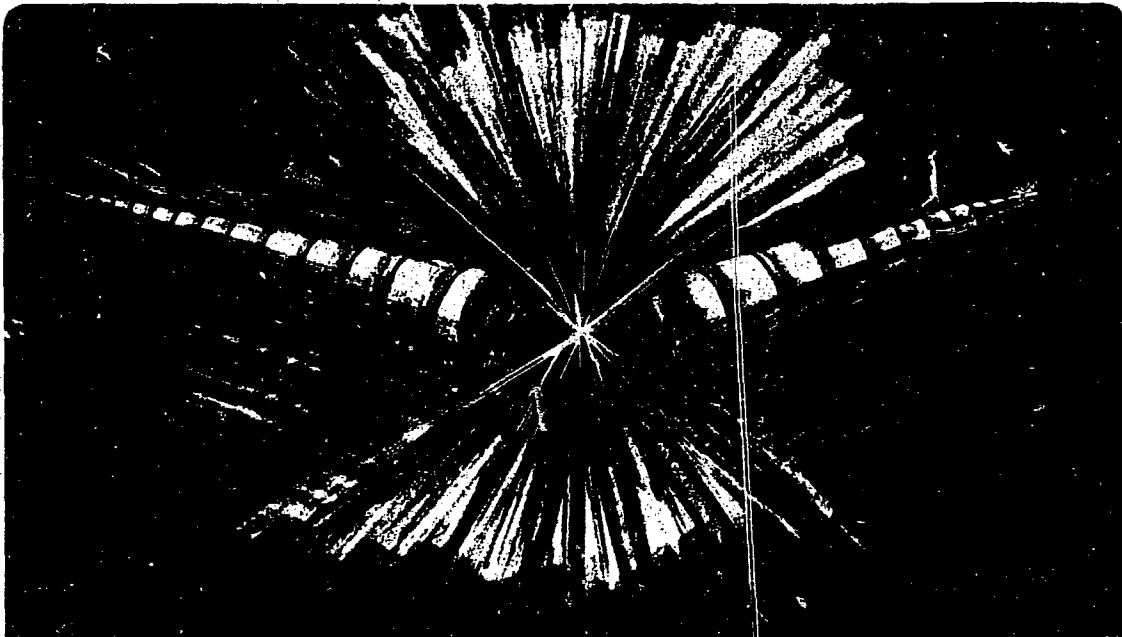

This report was done with support from the Department of Energy. Any conclusions or opinions expressed in this report represent solely those of the author(s) and not necessarily those of The Regents of the University of California, the Lawrence Berkeley Laboratory or the Department of Energy.

Reference to a company or product name does not imply approval or recommendation of the product by the University of California or the U.S. Department of Energy to the exclusion of others that may be suitable.

Ian G. Brown  
Lawrence Berkeley Laboratory  
University of California  
Berkeley, CA 94720

### ABSTRACT

An ion source is described in which a metal vapor vacuum arc is used to create the plasma from which the ions are extracted. Beams of a variety of ions have been produced, ranging from lithium up to uranium. At an extraction voltage of 25 kV we've measured an ion beam current of over 1 Ampere, with over 550 emu of the beam in an emittance of  $0.07 \pi$  cm. mrad (normalized). The ion charge state distribution varies with cathode material and with arc power; for uranium a typical distribution is peaked at  $U^{5+}$ , with up to 40% of the beam current in this charge state.

### INTRODUCTION

Progress in the development of high current ion sources has been significant in the last decade. The requirements of the magnetic fusion research program have fostered the development of neutral beam sources capable of delivering beams of hydrogen isotopes having equivalent currents up to the 100 Amp range [1,2]. The heavy ion fusion research program has seen the development of sub-microsecond beams with current approaching 1 MA [3-5]. The production of long pulse or dc ion beams from solids has not witnessed similar progress however. These kinds of beams have to-date been obtained by employing vaporization of the solid [6-9], or surface ionization [6,10], or sputtering [6,11,12]. Beams of uranium ions have been produced by a PIG source using sputtering, of intensity up to several tens of milliamperes [11].

The source that we've developed makes use of a dense plasma created directly from the solid material, as the medium from which ions are extracted. The plasma is created using a metal vapor arc discharge in vacuum. Extraction of ions from the plasma is accomplished using an accel-decel, multi-aperture grid system, and an intense ion beam composed of the cathode material is thereby produced. The application of metal vapor arcs to the production of beams of metal ions has been recognized recently by several workers [13,14]. This paper describes the embodiment of the concept that we've developed at LBL. Distinguishing characteristics of our source include a high quality beam and a long-pulse or dc extraction system.

### DESCRIPTION OF THE SOURCE

The MEVVA ion source is comprised of a metal vapor vacuum arc plasma source, a drift or plasma-shaping region, and a set of grids for ion extraction. The structure is housed within a simple vacuum chamber having a base pressure in the  $10^{-6}$  Torr range. A schematic of the source is shown in Figure 1.

\*Work supported by the Director, Office of Energy Research, Office of High Energy and Nuclear Physics, Nuclear Science Division, U.S. Department of Energy, under contract number DE-AC03-76SF00098.

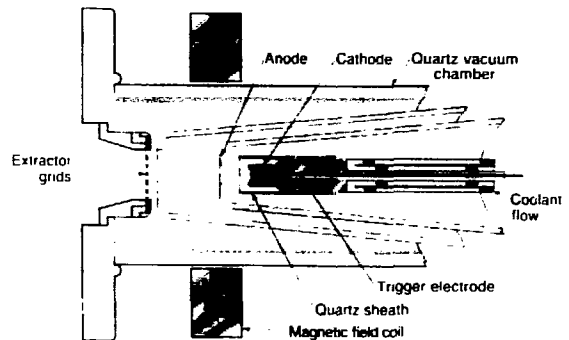

Figure 1. MEVVA ion source. Outline of the arc and extractor regions.

The metal vapor arc is a plasma phenomenon that has been well investigated for many years [15,16]; it is a field of research that has largely been the domain of the high current switching community. We've drawn upon this body of work, and most especially from the work of Gilmour and Lockwood [17] who have described a configuration which is particularly well-suited to the requirements of an ion source. In the metal vapor arc discharge, material is vaporized and ionized at the cathode surface through the formation of 'cathode spots' - minute regions of intense current concentration (though! to be of order  $10^6$  Amps/cm<sup>2</sup> or greater). Many such cathode spots participate in a typical vacuum arc discharge, the net result of which is the formation of a dense plasma of cathode material. This quasi-neutral plasma plumes away from the cathode toward the anode. A portion of the plasma plume impinges upon the anode, completing the electrical circuit and allowing the arc to persist for as long as the external current drive is maintained. The central part of the plasma plume, however, is allowed to flow through a central hole in the anode, and it is this component of the plasma that forms the medium from which ions are extracted. The plasma plume drifts through the post-anode region to the set of grids that comprise the ion extractor.

The ion extraction system consists of a set of three grids, each of which is an array of about 100 or more small holes of diameter about 1 mm or so, with an array diameter of 2 cm. The first grid (closest to the anode) is connected to the anode via a 500 Ohm resistor; the second (middle) grid is the electron suppressor and is held at about -1 kV; the third (outermost) grid is tied to ground. The arc (cathode-anode circuit) and the first grid are floated to extractor potential, which for our work to-date has been in the range 10 - 25 kV. Thus the ion accelerating voltage appears across the gap between grids one and two. This kind of grid system is well-understood and has been described by a number of authors [18,19].

MASTER

The arc is initiated by a trigger electrode located coaxially within the cathode and separated from it by a thin alumina sheath. A short pulse of several microseconds duration and of amplitude 10 - 20 kV causes sufficient initial ionization to allow the main arc to grow. Various other means of triggering the arc, apart from this coaxial trigger electrode configuration, are possible and we are currently investigating alternatives.

A magnetic field coil located at the anode plane serves to establish a small field throughout the plasma region, of strength up to a few hundred Gauss. The plasma plume is thereby guided maximally through the anode hole. This feature also adds an additional control over the density and radial profile of the plasma plume at the extractor, and thus allows for optimization of the extraction optics and production of a high quality beam. It is also possible that the magnetic field helps to suppress the growth of mhd instabilities in the arc plasma because of the favorable field curvature [20,21]; this would in turn produce a more quiescent beam than might otherwise occur. None-the-less, the magnetic field is not an essential feature of the source, and we've often operated with the magnet off.

We've constructed and tested several versions of the MEVVA ion source. Figure 1 is a schematic outline of the arc and extractor region of MEVVA II, that embodiment with which we've carried out most of our work. A photograph of the disassembled MEVVA II source is shown in Figure 2. We've also made a smaller version, MEVVA III, and a photograph of this source is shown in Figure 3.

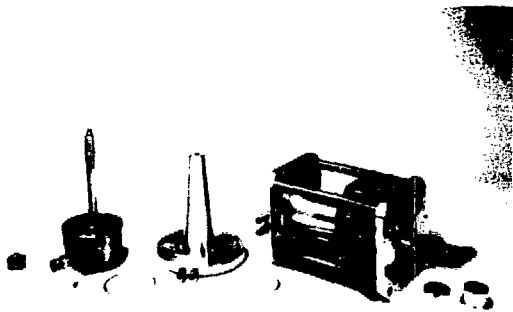

Figure 2. Photograph of the disassembled MEVVA II source.

#### SOURCE PERFORMANCE

For accelerator application at Lawrence Berkeley Laboratory we're mainly interested in producing intense uranium beams in the SuperHILAC (8.5 MeV/amu) and the Bevalac [22,23,24] ( $\approx 1$  GeV/amu), and thus we've run the MEVVA source using a cathode fabricated of depleted uranium. For simplicity in handling, however, most of our development work was done using tantalum. The complete range of cathode materials that we've tried includes: lithium, carbon, aluminum, silicon, titanium, iron, niobium, tantalum, gold, lead, uranium, and lanthanum hexaboride. In all cases, we've extracted beam and sampled the ion charge state distribution (CSD) using a time-of-flight diagnostic.

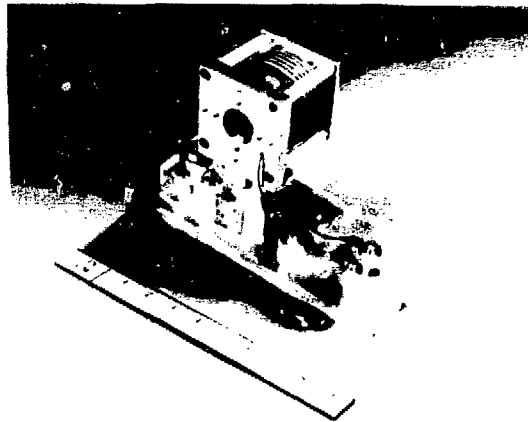

Figure 3. Photograph of MEVVA III.

In these tests the arc was driven by a 300 microsecond, 6-section, LC pulse line of impedance 0.5 Ohms with a Gibbs section on the front end to sharpen the rise-time. We've also run with an arc pulse length as long as 3 milliseconds, and we've operated the arc alone, without extraction of beam, for an on-time of 20 seconds. Repetition rate was typically about 2 pulses per second; the maximum rate of about 10 pps was set by the electronics available to us. The main concern to be addressed at high duty cycle or dc is the provision of adequate cooling.

Some conditioning of a newly-assembled source is needed. As is usual for high voltage, high current ion sources it is necessary to "bake in" the extractor grids in a preliminary conditioning run in order to obtain full voltage holding capability. The source is run repetitively while slowly increasing the arc current and extractor voltage. Once the grids have been conditioned in this way they'll hold full voltage indefinitely, requiring only minimal re-conditioning after exposure to atmosphere or handling. The cathode itself also needs a similar bake-in before a clean spectrum can be obtained. Interestingly, we observe that the small fraction of impurity ions present in the beam spectrum is further reduced as the pulse repetition rate is increased, presumably because of the reduction in cathode surface impurity level build-up, and perhaps also due to pumping of the arc environment by freshly deposited metal.

A bright and well collimated plasma plume is generated by that part of the arc plasma that flows through the anode hole. Figure 4 is a photograph of a uranium plasma plume in the MEVVA I source.

Note that the apparent blow-up of the beam is not a space charge effect since the plume is a quasi-neutral plasma, but is due to the magnetic ducting of the plasma; the plasma radius obeys the flux conservation rule  $B r^2 = \text{constant}$ . A thin aluminum foil was located so as to collect the mass of tantalum transferred by the plume. The mass of the foil was determined before and after a series of several hundred shots with an arc current of 440 Amps. The specific mass transfer was found to be  $4 \times 10^{-9}$  Kg/Coulomb of arc current. Note that this refers not to the total mass evolved from the cathode, but just to that component that streams

through the anode hole and is thus available to the extraction grids for the creation of beam. This value is only about 5% of the total cathode mass evolution, in the form of ions, as estimated by previous workers [17,25], and might be taken as an indication of the efficiency with which the plume transfers mass (and charge) out of the arc for our geometry. One might thus speculate that an improvement in this efficiency might be possible, of up to about an order of magnitude, by judicious choice of geometry.



Figure 4. Uranium plasma plume streaming through the anode hole (left) and expanding along the magnetic field en route to the extractor (right). MEVVA I.

We have used a gridded electrostatic energy analyzer to measure the longitudinal ion temperature of the plasma in the plume. We obtained a value of 15 eV, and this may be taken as a minimum value of the energy spread of the extracted ion beam also. Further, if we assume that the transverse ion temperature equals the longitudinal temperature (equilibration within the cathode spot plasma), then we can estimate a lower bound for the angular divergence of the extracted beam:

$$\theta_{\min} = v_{\perp} / v_{\parallel} = (T_{\perp} / \bar{Q} V_{\text{ext}})^{1/2}$$

which for  $\bar{Q} = 3$  for tantalum and an extraction voltage of 20 kV gives  $\theta_{\min} = 0.9^\circ$ , or an emittance  $\epsilon_{\min} = 0.013 \pi$  cm.mrad.(normalized). This is the minimum emittance obtainable, in the case that the extraction is ideal.

The current in the extracted beam has been measured using several different kinds of Faraday cups and calorimeters. These different techniques all agree with an uncertainty of no more than  $\pm 20\%$ . We have not measured beam current for all cathode materials and all operating conditions, but we have a fair sampling. The highest current that we've measured was 1.1 Amps; this was a tantalum beam (all charge states) extracted at 25 kV. We've also measured 0.5 Amps of niobium at 14 kV and 0.8 - 1.0 Amps of lithium at 17 kV. (These data were taken under different operating conditions, and should not be compared quantitatively to each other).

Another important diagnostic that we've employed is a 16-cup beam profile monitor [26]. An example of output from this diagnostic is shown in Figure 5. The smooth curve is a fitted Gaussian, from which the beam parameters were derived.

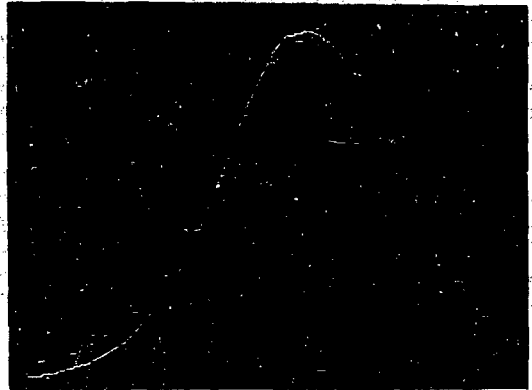
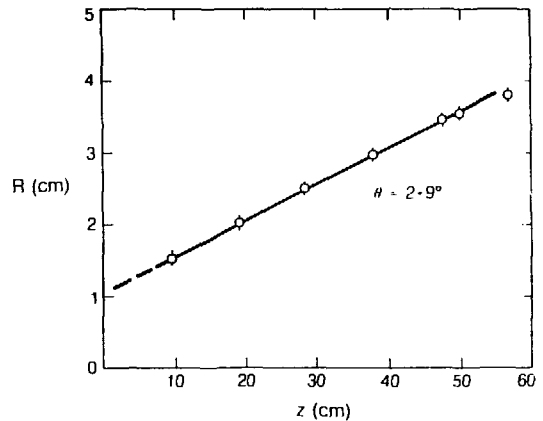

Figure 5. Radial current profile as measured by 16-cup profile monitor, with fitted Gaussian.

We have yet to carry out a detailed study of beam emittance using the traditional scanning technique [6]. We have however used beam profile measurements and the known geometry to obtain a reasonable estimate of emittance; on-line computer analysis of the beam profile monitor data [27] provides this emittance calculation. For the profile shown in Figure 5 the emittance is  $0.067 \pi$  cm.mrad.(normalized) measured to the half width of the radial current profile. Further measurements of beam quality are shown in Figure 6, where the beam half-width is plotted as a function of distance.



XBL 854 9939

Figure 6. Beam half-width vs. distance from extractor.

Here it's clear that the beam diverges linearly, that the envelope extrapolates back to the extractor radius, and that the divergence half-angle is 50 mrad or  $2.9^\circ$ . For the extraction voltage of 15 kV and taking an average charge state of 3+ for this tantalum beam, this corresponds to an emittance of  $0.036 \pi$  cm.mrad.(normalized). This is close to the best emittance we've been able to obtain to-date, without collimation.

The charge state distribution of the extracted ion beam has been measured by the time-of-flight method. The spectra obtained are typically very pure, containing a low component (less than a few percent) of species other than the cathode material; we can take this fortuitous behavior as evidence that the plasma originates solely at the cathode spots, and that the trigger electrode, trigger insulator and anode do not generate

significant impurities. The fit of the measured spectra to the calculated drift times is excellent. We've also measured the CSD using a magnetic analysis for some cases, and the data obtained in this manner confirm the time-of-flight spectra. We have noticed however that there can be some charge exchange of the beam ions after extraction.

Figure 7 shows the CSD for the case of uranium. The distribution is peaked at  $U^{5+}$ , with about 40% of the total beam current in this charge state. The CSD obtained varies with cathode material and with arc power. Higher Z materials burn with a higher arc voltage and the average charge state is concomitantly higher also: for uranium the arc voltage is up to about 100 volts, while for carbon it is about 10 - 15 volts and only the singly ionized  $C^+$  is seen in the CSD. The power dissipated in the arc also determines the CSD to some extent, and a plot of the average charge state as a function of arc power, for tantalum, is shown in Figure 8. Note that the range of arc power spanned is about 2 - 100 kW; for low Z cathodes the power dissipated can be an order of magnitude less.

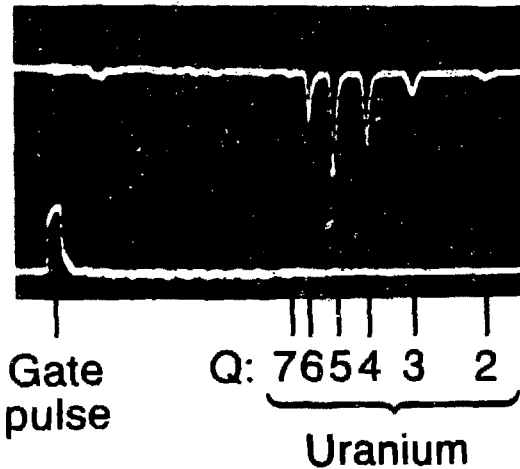

Figure 7. Uranium ion beam charge state distribution as measured by time-of-flight diagnostic.

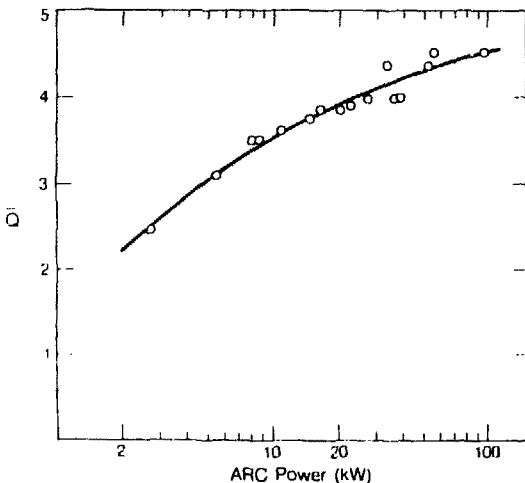

Figure 8. Mean charge state vs. arc input power, for tantalum.

It is interesting to note that a cathode fabricated from lanthanum hexaboride produces a spectrum containing both lanthanum ( $La^{2+}$ ,  $La^{3+}$ ) and boron ( $B^+$ ,  $B^{2+}$ ), this even though boron itself is non-metallic. One might thus generalize that the MEVVA source can produce beams containing species from non-conducting materials when that material is incorporated into a conducting compound, and this might also hold for cathodes of alloyed materials.

It is important that the beam intensity and CSD remain intact throughout the entire duration of the beam pulse, and that this hold true for extraction times longer than our usual 300 microsecond pulse. To address these concerns we've run some tests with a 3 millisecond pulse line, monitoring the time-of-flight spectra at a sequence of times throughout the pulse. In Figure 9 is shown the arc current pulse used and markers indicating the times at which time-of-flight spectra were monitored; these spectra are shown in Figure 10. We can make the following observations: (i). The beam CSD is similar throughout the 2.5 msec span monitored; (ii). The average charge state is higher earlier in the arc pulse when the arc current is higher; (iii). There is a gradual decrease in beam intensity throughout the pulse, as the arc pulse line current droops. Moreover, apart from a smooth decrease due to the falling arc current, very little jitter in the beam intensity and in CSD is seen; shot-to-shot-variation is minimal. (There is a small jitter in flight times because of imperfect extractor supply regulation).

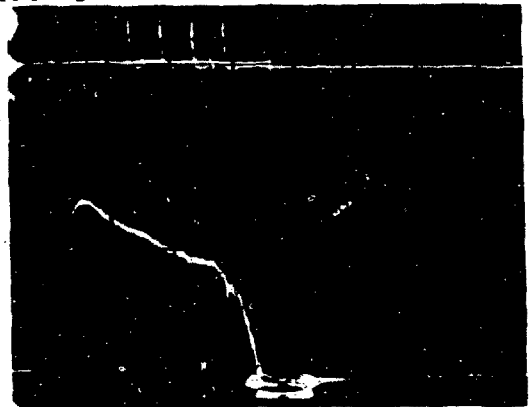

Figure 9. Long pulse arc current and time-of-flight timing markers. Sweep speed 0.5 msec/cm.

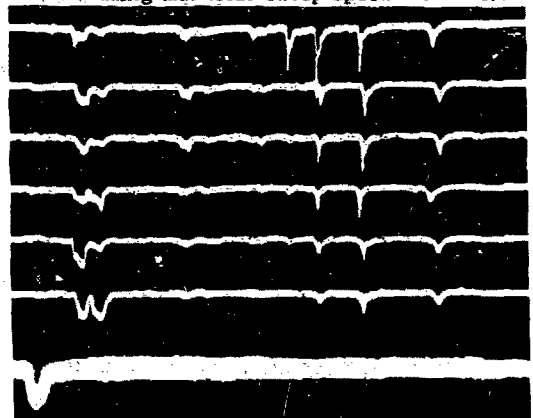

Figure 10. Time-of-flight CSD for the times indicated in Figure 9. Early times top, late times bottom.

## CONCLUSION

The metal vapor vacuum arc provides a means of creating a dense plasma from a conducting solid material, from which a high current ion beam can be extracted. The source described here is one embodiment of this concept. A great deal of research and development remains to be carried out to fully characterize and understand the MEVVA ion source behavior. Improvements in design parameters will be necessary for full exploitation of the concept. A major concern that is not so peripheral is the transport of these intense heavy ion beams in neutralization-unfriendly environments (eg, magnetic fields and accelerating columns). Given the potential of this kind of ion source, we might be confident that these developments will take place in the near future.

## ACKNOWLEDGEMENTS

This work is the result of a team effort, and I am deeply indebted to Jim Galvin, Jack Gavin and Bob MacGill for a steady stream of invaluable contributions without which this project would not have been possible.

## REFERENCES

1. "Proceedings of the Second Symposium on Ion Sources and Formation of Ion Beams", Berkeley, CA, Oct 22-25, 1974.
2. W. B. Kunkel in "Fusion", E. Teller, ed., Academic Press, New York (1981).
3. S. Humphries, Jr., Nuclear Fusion 20, 1549 (1980).
4. S. Humphries, Jr., R. N. Sudan and L. Wiley, J. Appl. Phys. 47, 2382 (1976).
5. S. Humphries, Jr., C. Eichenberger and R. N. Sudan, J. Appl. Phys. 48, 2738 (1977).
6. L. Valyi, "Atom and Ion Sources", John Wiley and Sons, New York, 1977.
7. J. Ishikawa and T. Takagi, Japanese J. Appl. Phys. 22, 534 (1983).
8. J. Ishikawa, Y. Takeiri and T. Takagi, Rev. Sci. Instrum. 55, 449 (1984).
9. A. Rockett, S. A. Barnett and J. E. Greene, J. Vac. Sci. Technol. B2, 306 (1984).
10. R. K. Feeney, W. E. Sayle, II, and J. W. Hooper, Rev. Sci. Instrum. 47, 964 (1976).
11. B. Gavin, S. Abbott, R. MacGill, R. Sorensen, J. Staples and R. Thatcher, IEEE Trans. Nucl. Sci. NS-28, 2684 (1981).
12. Y. Saito, Y. Mitsuoka and S. Suganomata, Rev. Sci. Instrum. 55, 1760 (1984).
13. S. Coffey, G. Cooper, S. Humphries, Jr., M. Savage and D. Woodall, Bull. Am. Phys. Soc. 29, 1314 (1984).
14. R. J. Adler and S. T. Picraux, Nucl. Instrum. and Methods B6, 123 (1985).
15. "Vacuum Arcs - Theory and Application", J. M. Lafferty, ed., John Wiley and Sons, New York, 1980.
16. IEEE Trans. on Plasma Science, Special Issue on Vacuum Discharge Plasmas, IEEE PS-11, Sep. 1983.
17. A. S. Gilmour, Jr. and D. L. Lockwood, Proc. IEEE 60, 977 (1972).
18. J. R. Coupland, T. S. Green, D. P. Hammond and A. C. Riviere, Rev. Sci. Instrum. 44, 1258 (1973).
19. T. S. Green, IEEE Trans. Nucl. Sci. NS-23, 918 (1976).
20. J. D. Jukes, Reports on Progress in Physics 31, 333 (1968).
21. W. M. Manheimer and C. Lashmore-Davies, "MHD Instabilities in Simple Plasma Configurations", Naval Research Laboratory, Wash. D.C., 1984.
22. J. R. Alonso, IEEE Trans. Nucl. Sci. NS-30, 1988 (1983).
23. J. R. Alonso et al, Science 217, 1135 (1982).
24. H. Gould, D. Greiner, P. Lindstrom, T. J. M. Symons and H. Crawford, Phys. Rev. Letters 52, 180 (1984).
25. C. W. Kimblin, J. Appl. Phys. 44, 3074 (1973).
26. J. E. Galvin and I. G. Brown, Rev. Sci. Instrum. 55, 1866 (1984).
27. J. E. Galvin and I. G. Brown, Lawrence Berkeley Laboratory Report LBL-18815. (Submitted for publication in Rev. Sci. Instrum.)

## DISCLAIMER

This report was prepared as an account of work sponsored by an agency of the United States Government. Neither the United States Government nor any agency thereof, nor any of their employees, makes any warranty, express or implied, or assumes any legal liability or responsibility for the accuracy, completeness, or usefulness of any information, apparatus, product, or process disclosed, or represents that its use would not infringe privately owned rights. Reference herein to any specific commercial product, process, or service by trade name, trademark, manufacturer, or otherwise does not necessarily constitute or imply its endorsement, recommendation, or favoring by the United States Government or any agency thereof. The views and opinions of authors expressed herein do not necessarily state or reflect those of the United States Government or any agency thereof.