

ANALYTICAL APPLICATIONS OF RESINS CONTAINING
AMIDE AND POLYAMINE FUNCTIONAL GROUPS

Gene Michael Orf

Ph.D. Thesis Submitted to Iowa State University

Mead Bond
Cocklefish

Ames Laboratory, DOE
Iowa State University
Ames, Iowa 50011

Date Transmitted: December 1977

NOTICE

This report was prepared as an account of work sponsored by the United States Government. Neither the United States nor the United States Department of Energy, nor any of their employees, nor any of their contractors, subcontractors, or their employees, makes any warranty, express or implied, or assumes any legal liability or responsibility for the accuracy, completeness or usefulness of any information, apparatus, product or process disclosed, or represents that its use would not infringe privately owned rights.

PREPARED FOR THE U.S. DEPARTMENT OF ENERGY
UNDER CONTRACT NO. W-7405-eng-82

EB

DISCLAIMER

This report was prepared as an account of work sponsored by an agency of the United States Government. Neither the United States Government nor any agency Thereof, nor any of their employees, makes any warranty, express or implied, or assumes any legal liability or responsibility for the accuracy, completeness, or usefulness of any information, apparatus, product, or process disclosed, or represents that its use would not infringe privately owned rights. Reference herein to any specific commercial product, process, or service by trade name, trademark, manufacturer, or otherwise does not necessarily constitute or imply its endorsement, recommendation, or favoring by the United States Government or any agency thereof. The views and opinions of authors expressed herein do not necessarily state or reflect those of the United States Government or any agency thereof.

DISCLAIMER

Portions of this document may be illegible in electronic image products. Images are produced from the best available original document.

NOTICE

This report was prepared as an account of work sponsored by the United States Government. Neither the United States nor the United States Department of Energy, nor any of their employees, nor any of their contractors, subcontractors, or their employees, makes any warranty, express or implied, or assumes any legal liability or responsibility for the accuracy, completeness, or usefulness of any information, apparatus, product or process disclosed, or represents that its use would not infringe privately owned rights.

Available from: National Technical Information Service
U. S. Department of Commerce
P.O. Box 1553
Springfield, VA 22161

Price: Microfiche \$3.00

Analytical applications of resins containing
amide and polyamine functional groups

by

Gene Michael Orf

A Dissertation Submitted to the
Graduate Faculty in Partial Fulfillment of
The Requirements for the Degree of
DOCTOR OF PHILOSOPHY

Department: Chemistry
Major: Analytical Chemistry

Approved:

In Charge of Major Work

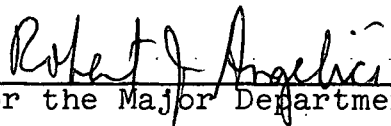
For the Major Department

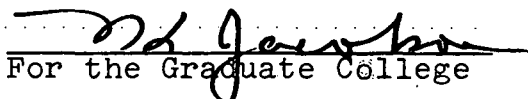
For the Graduate College

Iowa State University
Ames, Iowa

1977

TABLE OF CONTENTS

	Page
I. INTRODUCTION	1
II. SURVEY OF THE LITERATURE	4
A. Introduction	4
B. Resins Selective for Uranium, Thorium and Zirconium	5
C. Resins Selective for Noble Metals	12
D. Resins Containing Polyamine Functional Groups	19
III. THEORY OF COMPLEXING RESINS	26
A. Introduction	26
B. Equilibrium	27
C. Effect of Polymer Structure	32
D. Effect of Solution Medium	35
IV. N,N-DIBUTYL AMIDE RESIN FOR THE CONCENTRATION AND SEPARATION OF METAL IONS	38
A. Apparatus and Reagents	38
B. Synthesis and Characterization	40
C. Sorption Properties of Amide Resins Prepared	49
D. Separation Scheme	54
E. Interference Studies	55
F. Analysis of Ore Samples	71
G. Concentration of Gold	73
H. Capacity Studies	76
I. Conclusions	79

v

V. TRIETHYLENETETRAMINE RESIN FOR THE CONCENTRATION AND SEPARATION OF METAL IONS	81
A. Apparatus and Reagents	81
B. Synthesis, Characterization and Capacity Studies	81
C. Separation Schemes	86
D. Interference Studies	88
E. Sorption of Anions	106
F. Preparation of Higher Capacity Resins	108
G. Conclusions	110
VI. LITERATURE CITED	112
VII. ACKNOWLEDGEMENTS	118

Analytical applications of resins containing
amide and polyamine functional groups

Gene Michael Orf

Under the supervision of James S. Fritz
From the Department of Chemistry
Iowa State University

Resins are prepared by chemically bonding N,N-dialkyl amides and polyamine functional groups to Amberlite XAD-4. These resins are applied to the concentration of metal ions from dilute aqueous solution and the rapid separation of metal ions by high-speed liquid chromatography with continuous on-line detection of the eluent stream.

A dibutyl amide resin is used for the separation of uranium(VI), thorium(IV), and zirconium(IV) from each other and several other metal ions. Uranium(VI) and thorium(IV) are determined in the presence of large excesses of foreign metal ions and anions. A practical application of the amide resin is studied by determining uranium in low grade uranium ores. The amide resin is also used for the selective concentration of gold(III) from sea water.

Work performed for the U.S. Energy Research and Development Administration under Contract No. IS-T-784.

A triethylenetetramine resin is used for the separation of copper(II) from equal molar amounts and large excesses of nickel(II), cobalt(II), zinc(II), cadmium(II), iron(III) and aluminum(III). Copper(II), nickel(II), zinc(II), cobalt(II) and cadmium(II) are determined in the presence of large excesses of calcium(II) and magnesium(II). The resin was found to be selective for silver(I) and mercury(II) at low pH values and a rapid separation of equal molar amounts of copper(II) and silver(I) was performed. The resin was also found to have an affinity for anionic metal complexes such as iron(III)-tartrate when the resin is in the hydrogen form. A study of the retention of the anions chromium(III)-tartrate and dichromate at various pH values was performed to better understand the anion exchange properties of the resin.

Triethylenetetramine resins were also prepared from polystyrene gel to make a resin with higher capacities for copper(II).

I. INTRODUCTION

Literally hundreds of different functional groups have been bonded to inert matrices or have been incorporated into inert matrices by polycondensation in an attempt to prepare ion-exchange resins selective for particular metal ions. Most of the functional groups incorporated into resins are ones found to be selective for metal ions by solvent extraction. In almost all cases these have been metal chelating agents rather than coordination compounds.

The usual goals in preparing a selective ion-exchange resin are to make a resin that is selective for one particular metal ion or one from which several metal ions can be retained and successively eluted. Many resins are selective only for groups of ions and are used for the separation or concentration of a group of ions for subsequent analysis by techniques such as X-ray fluorescence, neutron activation analysis or atomic absorption. Also, of the many selective resins prepared there are only a few studies on the use of these resins for the rapid chromatographic separation and continuous on-line determination of metal ions. In the present work two different resins are prepared with the intention of filling some of the gaps mentioned above.

Certain N,N-disubstituted amides have been shown to be very selective reagents for the solvent extraction of uranium, thorium and zirconium (1). These amides coordinate

to metal ions through the basic oxygen atom in the molecule in the same manner as trialkyl phosphates, ketones, and sulfoxides. The amides were found to have an order of selectivity of uranium(VI)>thorium(IV)>zirconium(IV). The extracting power of these amides is due both to inductive effects and steric effects. Other work reported the best amide extractant for uranium and thorium to be N,N-dibutylacetamide (2,3).

The great selectivity of these reagents made it desirable to prepare an amide resin, the goals being to obtain equal selectivity, and to make rapid separations of uranium, thorium and zirconium from each other and from other ions. Also, little has been done on the synthesis and use of a selective resin containing functional groups that coordinate to a metal ion only through an electron donating group. The only example found of such a resin was one made by Kennedy (4). He synthesized a resin by polymerizing di-allyl allylphosphonate with benzoyl peroxide. From one to three meq/g of iron(III), uranium(VI), cobalt (II) and lithium (I) were taken up by the resin from nonaqueous solvents such as ketones and primary alcohols. Lesser amounts of metal ion were taken up from aqueous solution.

Amines have long been known to be selective for copper and other transition metals, and resins containing polyamine functional groups have been prepared previously (5-13).

However, these resins have never been used for rapid separation of heavy metals from each other and from other groups of metals. Also, little has been done to examine the use of these resins for the sorption of anions. Therefore, an amine resin was prepared. The objectives were to make rapid separations of copper from other transition metals, to separate several transition metals from large excesses of alkaline earth metals, and to study the sorption of some anions by the amine resin. In the separations performed on both resins, the metal ions are determined by continuous on-line monitoring of the eluent stream.

II. SURVEY OF THE LITERATURE

A. Introduction

The development of complexing resins began in 1939 when Erlenmeyer and Dahn chromatographed various cation mixtures on powdered 8-hydroxyquinoline (14). Also in 1939, the possibility of synthesizing resins that contained active functional groups selective towards particular ions was first suggested (15). Skogseid first attempted to make such a resin in 1940 when he prepared a polystyrene resin containing a group similar to dipicrylamine that was selective for potassium ions (16). Since these first attempts a great deal of progress has been made in both the synthesis and application of selective resins for the concentration and separation of metal ions.

Publications on selective ion exchange resins since 1939 are so numerous that an attempt to discuss all of them would be impractical. Therefore, only those articles which have a direct bearing on the present research will be mentioned. A more comprehensive examination of the history and recent development in selective resins can be found in a number of review articles. Reviews on the early developments of selective resins are given by Hale (17) and Millar (18). Reviews on the development of selective resins from the 1960's to the present are given by Riemann and Breyer (19),

Schmuckler (20), Blasius and Brozio (21), Hering (22), Marhol (23), Myasoedova, Eliseeva and Savvin (24), Saldadze and Kopylova (25), and Walton (26).

B. Resins Selective for Uranium,
Thorium and Zirconium

A large number of selective resins have been prepared for the concentration of uranium, thorium, and zirconium, and for the separation of their ions from each other and several other metal ions. The concentration and separation of uranium from several matrices has been of particular interest because of the increasing use of uranium as a source of energy.

Kennedy and Davies prepared polymers of partially esterified phosphates and phosphonates and found them to be selective for thorium(IV), uranium(VI), iron(III) and rare earths (III) at low pH values (27). This selectivity was attributed to the fact that these ions are bound to the resin by covalent or partially covalent bonds, forming complexes of

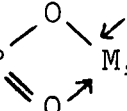
the type Resin-P  M, whereas alkali, alkaline earth and

divalent transition elements are bound by mainly ionic bonds. Using a mono-acidic allyl phosphonate resin, uranyl ion was sorbed to saturation capacities of 120 mg uranium/gram of resin from 0.1 to 0.2 N nitric acid solutions containing

calcium(II), copper(II) and cobalt(II). The uranium was eluted quantitatively from the resin with solutions of 0.1 - 0.3 M sodium carbonate but could not be separated from iron(III) or lanthanum(III) which were also strongly sorbed under acidic conditions. Another phosphorus-containing resin used for the selective sorption of uranium and thorium is one containing the group HO-C-C=C-COOH which takes up uranium and thorium selectively from acidic media greater than 0.4 M in nitric or hydrochloric acid (28). Cellulose phosphate has a very high affinity for certain ions like thorium(IV), titanium(IV), cerium(IV), iron(III), zirconium(IV) and uranium(VI); divalent cations are not sorbed. This resin is very useful for analytical separations because it can sorb these ions from 1 M acid solutions. Work with this ion exchange material has shown that it can extract uranyl ion from very dilute solutions (29) and it has been used for the separation of uranium from copper, lead, cadmium, and zinc (30).

A number of resins have been synthesized in which very specific chelating agents are incorporated into macromolecules. A resin prepared by the copolymerization of methacrylactone (1-hexene-2-methyl-3,5-dione) and glycol dimethacrylate was found to be selective for ferric and uranyl ions under acidic conditions (31). No attempts were made to perform any separations or to make any capacity or

equilibrium studies with this resin. A salicylic acid-formaldehyde polymer also shows high selectivity for uranium(VI) and iron(III) (32). No separations were attempted but determinations of distribution ratios between solutions of various pH values and the polymer suggest the separation of these ions from several other ions.

Manecke and Danhauser synthesized a resin by the nitrosation and oximation of carbinols which forms stable complexes with nickel(II), copper(II), cobalt(II) and uranium(VI) ions (33). This resin has the following structure.

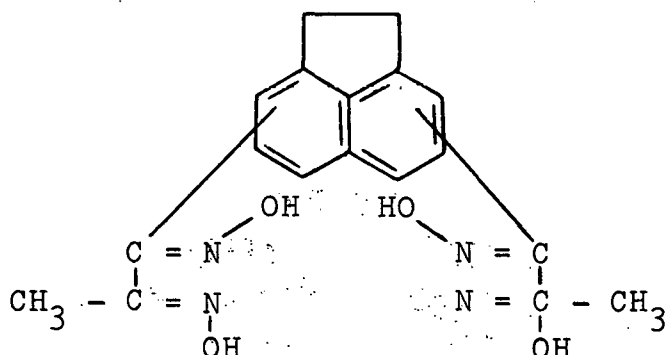

Bayer condensed o-aminophenol with glyoxal and obtained a polymer of glyoxal-bis-2-hydroxyanil (34). This polymer

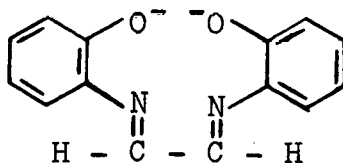

showed a high affinity for copper, uranyl, and nickel ions.

Myasoedova and Bol'shakova condensed phenols with formaldehyde to produce resins that concentrate elements for which precipitates of the tannates of organic cations have been observed (35). These elements include beryllium, gallium, germanium, titanium, tin, zirconium, niobium, tantalum, molybdenum, tungsten, uranium and thorium.

A number of 8-hydroxyquinoline-based resins have been prepared. Depending on the type of synthesis, these are selective for several different heavy metals. One of these obtained by the polycondensation of 8-hydroxyquinoline, resorcinol and furfural was used for the separation of uranium and several radioactive isotopes of the elements (36). Condensing the 8-hydroxyquinoline in the presence of different metal ions also changes the properties of the resin. A sodium hydroxyquinolate resin can be used for separating uranium and zirconium; zirconium and cerium; ruthenium, zirconium and cerium; and strontium and yttrium, whereas the barium hydroxyquinolate is suitable for the separation of ruthenium, zirconium, uranium and cerium (37).

Myasoedova et al. also synthesized a number of resins by introducing selective functional groups onto polystyrene-divinylbenzene copolymers. One such resin was prepared by nitration and reduction followed by diazotization of the amino styrene to produce a resin containing the o-arsono-o'-hydroxyazo group (38). This resin was very selective for

uranium, thorium and zirconium at very low pH values. They also synthesized similar resins by cyanurating hydroxy containing polymers such as cellulose, polyvinyl alcohol, and dextrans, then aminating, diazotizing, and coupling as with the polystyrene (39). The results obtained with these resins were very similar to those obtained with the other resins.

Marhol and Cheng synthesized a number of resins by incorporating other reactive functional groups into polystyrene-divinylbenzene resins containing iminodicarboxylic acid groups (40). The addition of groups such as carbonyls, sulfides and phosphates altered the selectivity of the iminodicarboxylic acid group and made possible some separations that could not be done on the original resin. These resins included some which were very selective for thorium and uranium.

Vernon and Eccles attached 8-hydroxyquinoline (41) and 4-(2-pyridylazo) resorcinol (42) to Amberlite XAD-2 and found them to be quite selective for uranium at low pH values, but the resin's capacity for uranium was very low.

Marhol et al. synthesized a resin by copolymerization of α -phenylvinylphosphonic acid and acrylic acid (43). The selectivity of this resin decreased in the order thorium(IV) > scandium(III) > iron(III) > uranium(VI) divalent metal ions. This differed from other resins in which the phosphonic acid

group was directly on the benzene ring, in which case the resin was more selective for uranium than iron. It was shown that thorium, scandium, iron and uranium could be easily separated from the lanthanides and divalent elements.

Fritz and Moyers prepared arsonic acid (44) and diamine-tetraacetic acid resins (45) that were selective for uranium and thorium in very acidic media. One hundred percent recovery of thorium and uranium from aqueous solution by the arsonic acid resin could be obtained at pH 1 and pH 2, respectively. Thorium could be separated from all other metal ions by the addition of EDTA to complex foreign metal ions. The diamine tetraacetic acid resin retained copper(II); uranium(VI), thorium(IV) and zirconium(IV) from acidic solutions. Uranium, thorium and zirconium could be separated from each other and from other metal ions by sorption of the three metals from 0.01 M hydrochloric acid and then sequential elution with 0.1 M hydrochloric acid, 4.0 M hydrochloric acid and 1.0 M sulfuric acid.

Davies et al. investigated the extraction of uranium from sea water with several organic and inorganic adsorbents (46). Since uranium is in the form of a very stable uranyl tricarbonate complex in sea water, a large number of functional groups were investigated in an attempt to find some which could compete with the carbonate complex. The resins investigated contained mono- and di-basic phosphoric and phosphonic

acid groups, 8-hydroxyquinoline, kojic acid, salicylic acid, aminophosphonic acid, aminophosphoric acid, and arsonic acid groups. The uptake of uranium by some of the organic resins is shown in Table 1. Only the arsonic acid resin reached values high enough to be of practical interest. However,

Table 1. Uptake of uranium by complexing resins.

Resin	Functional Group	Time of Contact (days)	Uptake ($\mu\text{g/g}$ of dry H^+ form)
Deacidite FF	$-\text{R}_3\text{NCl}$	84	0.2
Zeo-Karb 226	$-\text{COONa}$	36	1.5
Polystyrene methylene phosphonic acid	$-\text{CH}_2\text{PO}(\text{ONa})_2$	88	25.0
8-Hydroxyquinoline	$-\text{N}=\text{CN}_9\text{H}_5\text{NONa}$	81	13.0
Resorcinol arsonic acid	$-\text{AsO}(\text{ONa})_2$	112	1010.0

slow hydrolytic attack on the carbon-arsenic bond of the resin causing a steady loss of capacity makes this resin economically unsuitable for the recovery of uranium from sea water. Another resin that is suitable for concentrating trace amounts of uranium from sea water is a poly Schiff base prepared by Bayer (47).

Resins synthesized for the selective sorption of zirconium are not nearly as common as resins selective for uranium and thorium, but one interesting resin is one made of Blasius and Kynast (48). They introduced the following

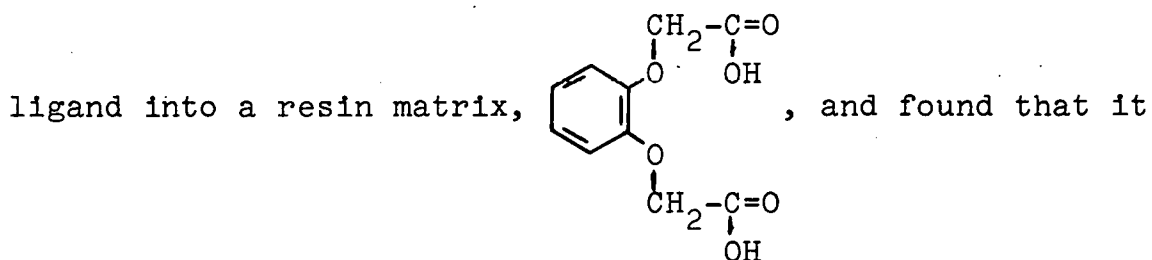

formed very strong octahedral complexes with zirconium and used it to separate zirconium from hafnium. Other resins have also been suggested for the separation of zirconium from other metal ions (49,50).

C. Resins Selective for Noble Metals

Noble metals are usually found in natural materials in very low concentrations and for this reason a preliminary separation and concentration is often necessary for their determination. Several selective resins have been prepared for this purpose. The most widely used of these resins is a benzylisothiuronium resin first prepared by Koster and Schmuckler (51). This resin has been sold commercially under the trade names SRXL resin and Sraflon NMRR resin. Koster and Schmuckler noted that the noble metals have the important property that in a certain environment they may be stabilized in a d^8 electronic configuration and form

square-planar complexes with various ligands. They used this principle to prepare chelating resins on a styrene-divinylbenzene copolymer matrix which would bind osmium(VIII), rhodium(III), iridium(IV), palladium(II), platinum(IV), and gold(III) strongly but did not bind the base metals at all. The ligands studied were the benzylisothiuronium chloride (BTU) ligand and sulphaguanidine (N'-amidinosulfanilamide) (SG). The resins contain double bonds that give them redox properties. Therefore, the metals are reduced by the resin to the oxidation state at which square complexes are formed, namely metallic osmium, rhodium(I), iridium(I), palladium(II), platinum(II), and gold(III). The resins are also capable of reducing gold(III) to metallic gold. The resins were found to bind the metals in the following ways; using palladium as the example:

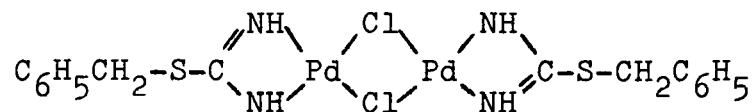

and

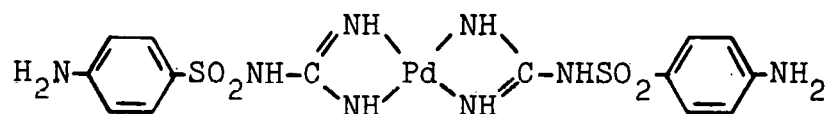

Green et al. used paper disks containing the BTU resin prepared by Koster and Schmuckler to collect trace noble elements for X-ray spectrographic and neutron activation determinations (52). They found that the resin could

quantitatively collect milligram quantities of gold from solutions containing up to 200 grams per liter of common metals and high concentrations of hydrochloric and nitric acids.

Gulko, Feigenbaum and Schmuckler used the sulfaguanidine resin to separate palladium(II) and platinum(II) since the resin has a much greater affinity for palladium than platinum under certain conditions (53). The separation was performed by passing a mixture of the two metals through a column at pH 2. Any platinum adsorbed along with the palladium was washed out with 0.5 M hydrochloric acid and the palladium was then quantitatively eluted from the resin with 3-4 M hydrochloric acid.

Nadkarni and Morrison used Srafion NMRR resin for the concentration of noble metals and silver from geological materials so that they could be determined by neutron activation analysis (54,55). The metals were taken up from solutions of pH 1.5-2. It was found that the metals could be eluted from the resin with a 5% aqueous solution of thiourea which was 0.05 N in hydrochloric acid.

Trace amounts of gold, platinum, iridium, palladium, ruthenium, osmium and silver were determined in USGS standard rocks, and the same metals were also determined in a meteorite and a lunar soil sample.

Blount et al. also used the NMRR resin for the trace analysis of gold in geological samples by collecting the gold on the resin, pressing it into pellets, and determining the gold by X-ray fluorescence (56).

Sundberg found that the purification of gold from meteorites could be greatly simplified by directly sorbing solvent extracted gold onto the NMRR resin (57). He found that gold halide complexes could be quantitatively sorbed from ethyl acetate, isopropanol and MIBK and then readily eluted from the resin with 5% thiourea in 0.5% hydrochloric acid.

Myasoedova et al. prepared chelate sorbents containing various nitrogen and sulfur functional groups from cross-linked dextrans for the concentration and separation of noble metals (58). The monomeric reagents used were pyrazalone derivatives, rhodanine, 8-amino and 8-mercaptoquinoline, and dithizone. The metals studied were

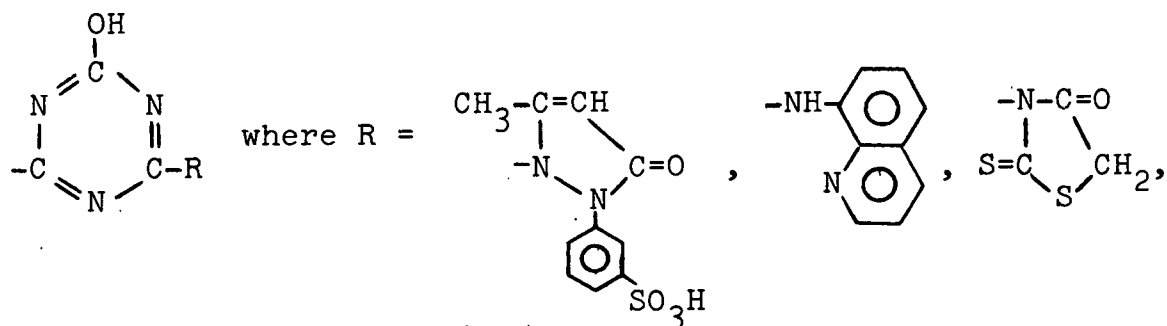

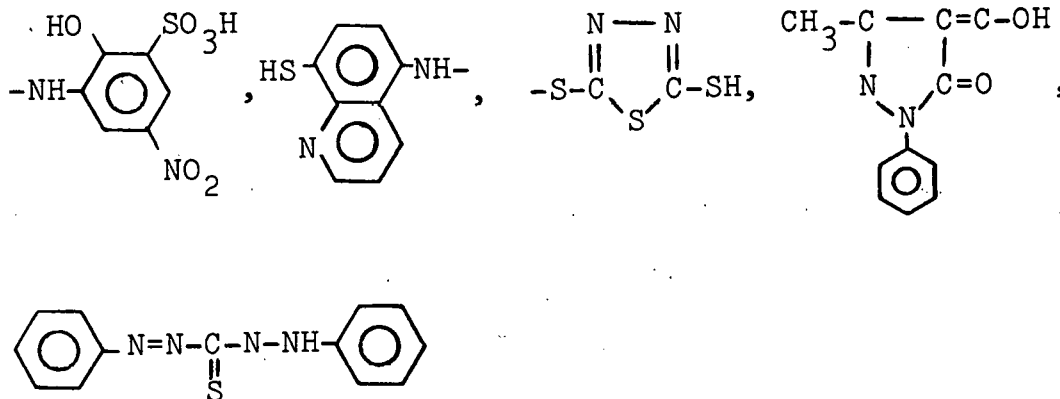

palladium(II), platinum(II), rhodium(III) and gold(III).

All the sorbents extracted palladium from 1 N sulfuric acid solutions. Platinum and gold were extracted only by resins containing rhodanine and 8-mercaptoquinoline groups. None of the resins sorbed rhodium. No method was given for eluting the sorbed ions from the resin, and determination of the amount of ions sorbed by the resin was done after wet ashing of the resin in perchloric and nitric acids.

Myasoedova et al. also prepared similar resins from polystyrene-divinylbenzene copolymers and studied the sorption of the same ions from hydrochloric, sulfuric and perchloric acid solutions (59). Palladium and gold were almost completely sorbed by all of the sorbents. Palladium was sorbed from all of the acids. Gold was only studied in hydrochloric acid. Platinum was absorbed to the greatest extent from hydrochloric acid solutions. Rhodium was not

completely sorbed by any of the resins. Desorption of the ions from the resin was a problem. The resins often decomposed in acid, but they found that palladium and platinum could be eluted from 8-aminoquinone and sulfophenylmethylpyrazolone resins with 3% solutions of thiourea in 0.1 N hydrochloric acid on heating.

Savvin et al. also prepared similar resins on styrene-divinylbenzene macroporous copolymers (60). The most interesting of these was one prepared by aminating the chloromethylated matrix with 8-aminoquinoline. This structure favors the formation of cyclic complexes with the noble metals. The chloro complexes $[\text{PdCl}_4]^{2-}$, $[\text{PtCl}_3\text{H}_2\text{O}]^-$ and $[\text{PtCl}_4]^{2-}$ were completely sorbed by the resin independent of the nature of the acid, but $[\text{PtCl}_6]^{2-}$ and $[\text{PtCl}_5\text{OH}]^{2-}$ were sorbed completely only from hydrochloric and sulfuric acid. The sorption of platinum from perchloric acid was only slight. This was probably because platinum(IV) can be reduced to platinum(II) in hydrochloric and sulfuric acids, but not in perchloric acid. Rhodium(III) and iridium(III) were not retained. This was attributed to the fact that their complexes retained an octahedral configuration and could not complex with the resin because of steric factors. These factors allowed the separation of milligram amounts of palladium, platinum and gold from microgram amounts of rhodium and iridium. The separation was achieved by passing

a solution of the metals in 3 N hydrochloric acid through a column of the resin, under which conditions the rhodium and iridium were eluted. The palladium, platinum and gold ions were then eluted with a hot solution of thiourea in 0.1 N hydrochloric acid.

Dedkov et al. prepared a resin selective for noble metals by coupling aminopolystyrene with the diazonium salt of 2-sulfo-4-nitro-6-aminophenol (61). They studied the sorption

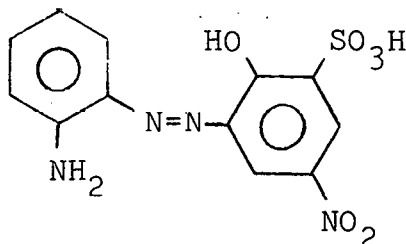

of the metals from sulfuric and hydrochloric acid media. The resin readily sorbed palladium and gold from sulfuric acid while platinum was only partially sorbed and rhodium was not sorbed at all. Rhodium and platinum were not sorbed at all from hydrochloric acid and the range over which palladium and gold were sorbed was very restricted. The order in which the metals were sorbed was palladium>gold>platinum>rhodium. The fact that palladium was sorbed from sulfuric acid and rhodium was not, was used to separate the two and to determine the amount of rhodium in palladium metal.

Moyers and Fritz prepared a hexylthioglycolate resin by bonding the group to Amberlite XAD-4 through an ester linkage (62). This resin was selective for silver(I), mercury(II), gold(III), and bismuth(III) from acidic solution. All of the ions were retained from 0.1 M perchloric or hydrochloric acid solutions. The ions were then separated by eluting bismuth with 0.5 M hydrochloric acid, silver with 2 M hydrochloric acid, mercury with 6 M hydrochloric acid, and gold with 10^{-3} M thiourea in pH 3 hydrochloric acid.

D. Resins Containing Polyamine Functional Groups

Many resins containing various amine functional groups have been prepared for the sorption of heavy metals and some anions. However, little work has been done on the separation of cations or anions with these resins.

In 1957 Shepherd and Kitchener prepared rods of a resin based on poly(ethyleneimine), $-[\text{CH}_2\text{CH}_2\text{NH}]_n-$, cross-linked with ethylene dibromide (5). The resin was used to prepare titration curves for different anions. This was done by immersing 50-100 mg of resin in acids of different concentrations, shaking until equilibrium was obtained, and measuring the pH of the external solution. The acids studied were acetic, nitric, hydrochloric, toluene-p-sulphonic, naphthalene-2-sulphonic acid, the free acids of Orange II

[4'-(2-hydroxy-1-naphthyl) azo-benzene-4-sulphonic acid], and Chlorazol Sky Blue {3:3'-dimethoxydiphenyl-4:4'-ylenebis-[azo-7-(4-amino-8-hydroxynaphthalene-1:3-disulfonic acid)]}. The affinity of the resins for the anions was found to be Chlorazol Sky Blue>acetate>chloride>nitrate>toluene-p-sulphonate>naphthalene-2-sulphonate>Orange II. They also found that the resin sorbed transition elements such as mercury, cobalt, nickel, and copper, with the strongest affinity for copper.

In 1958, Nonabaki et al. prepared a similar resin, complexed the resin with copper(II) and cobalt(III) ions, and studied the $\text{OH}^- - \text{Cl}^-$ exchange equilibria of the metal-polyamine complexes (6). They concluded that metal ions can be used as polyvalent centers of anion-exchange if they are introduced into the resin phase as the complex. However, for practical purposes there were many problems such as the precipitation of cupric hydroxide inside the resin when the resin was treated with sodium hydroxide.

Kopylova et al. also studied the complex-forming properties of a ethylenediamine resin (7). They found that when this resin came into contact with solutions of the amine, glycine, tartrate, citrate, oxalate, and acetate complexes of copper(II), these complexes break down to form complexes in the resin phase. They used this fact to determine the stability constants of copper(II), zinc(II),

nickel(II) and cadmium(II) by the competitive reactions method, using ethylene diamine as the monomeric ligand. The average stability constants for the four ions with the ethylene diamine resin were as follows:

<u>Ion</u>	<u>K_{MR}</u>
Cu^{2+}	1.93×10^8
Ni^{2+}	7.08×10^5
Zn^{2+}	5.83×10^4
Cd^{2+}	4.96×10^4

Egawa and Saeki prepared resins containing diethylenetriamine, triethylenetetramine, and tetraethylenepentamine functional groups (8). These resins were prepared from polystyrene beads which varied from 0.5 - 7% in divinyl benzene cross-linking. They studied the effects of cross-linking and pH on the sorption of several metal ions. They found that a decrease in resin cross-linking caused an increase in the uptake of metal ions. This was attributed to steric hindrance with high cross-linking which prevented chelate formation. The minimum pH values at which various metal ions began to complex with the triethylenetetramine resin were as follows:

<u>Ion</u>	<u>pH</u>
Hg ²⁺	0.5
Cu ²⁺	2.5
Zn ²⁺	3.2
Ni ²⁺	3.7
Cd ²⁺	4.0
Co ²⁺	4.0
Mn ²⁺	5.0

They also found that the resins had a great affinity for gold(III) from hydrochloric acid solutions and had no affinity for magnesium(II), strontium(II), or thorium(IV). The possibilities of separating mercury(II) and copper(II) at pH 1-2 and copper(II) from nickel(II) and zinc(II) at pH 3-4 were also suggested.

Saldadze et al. attached 4-vinylpyridine and 2,5-methylvinylpyridine to divinylbenzene copolymers in an attempt to prepare resins with great selectivity for silver(I) over copper(II), cobalt(II), nickel(II), cadmium(II), and zinc(II) (9). By introducing an alkyl substituent into the α -position with respect to the pyridine nitrogen, the coordination properties of the resin with respect to di- and trivalent transitional metals which form square, tetragonal or octahedral complexes are reduced. On the other hand, silver forms linear complexes and the introduction of an alkyl group

promotes complex formation because of the inductive effect. These resins did have a much higher affinity for silver than the other ions and made it possible to selectively sorb silver from solutions of the alkali, alkaline earth, and several transitional elements.

Dingman and co-workers cross-linked ethylenediamine, triethylenetetramine, tetraethylenepentamine, and polyethyleneimines with toluene-2,4-diisocyanate and studied the chelation of copper(II), nickel(II), zinc(II) and cobalt(II). They found that the metallic elements could be concentrated and measured in the presence of large quantities of alkali and alkaline earth elements. The strength of the metal amine complexes were in the order copper>nickel>zinc>cobalt. The pentamine resin was found to be the most efficient in copper uptake per amino content, and the tetramine was next. The polyethyleneimines were well below their expected capacities. Their findings on the effects of cross-linking and pH were similar to those in the work discussed earlier.

Leyden and co-workers prepared polyamine-polyurea resins and also amine and carbamate resins on silica gel matrices to concentrate transition metals from dilute solution and determine them by X-ray fluorescence (11,12). The polyamine-polyurea resin was used to concentrate and determine cobalt(II), zinc(II), copper(II), nickel(II), iron(III) and chromium(III) from sea water. The effect of pH on the

chelation of the above metal ions with the amine resins was studied by equilibrating 2 mmoles of cation perchlorate with 100 mg of resin and adjusting the pH and ionic strength with perchloric acid, sodium hydroxide and sodium perchlorate. The pH for 50% extraction of various ions with an ethylenediamine resin were as follows:

<u>Ion</u>	<u>pH for 50% extraction</u>
Hg ²⁺	1.7
Cu ²⁺	4.5
Zn ²⁺	5.5
Ni ²⁺	6.0
Pb ²⁺	6.8
Eu ³⁺	6.9
Mn ²⁺	9.2
Fe ³⁺	4.0
Ag ¹⁺	6.0
Cd ²⁺	6.8
Cr ³⁺	7.0
Co ²⁺	7.6

Melby prepared polymers containing chelating ligands based on derivatives of N,N''-bis(2-pyridylmethyl)-2,2'-diaminobiphenyl

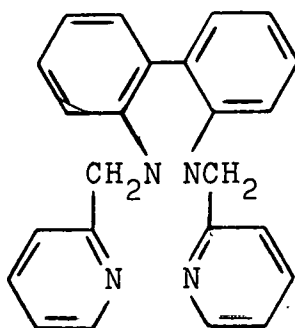

and N-(2-pyridylmethyl)-2,2'-diaminobiphenyl

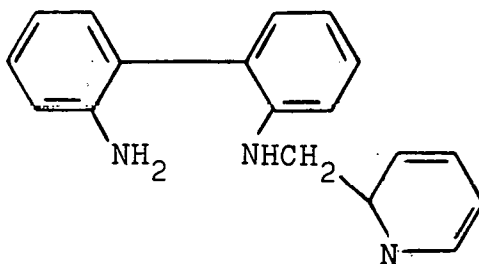

to selectively remove copper(II) and silver(I) or nickel(II) from acidic aqueous transition metal ion mixtures (13).

III. THEORY OF COMPLEXING RESINS

A. Introduction

Conventional ion exchange resins separate ionic constituents in the following ways (63):

1. They sorb ionic constituents in the presence of nonionic substances.
2. Anionic substances are taken up by ion exchange resins, and cationic substances by cation exchange resins.
3. Ions of higher valence are preferentially sorbed in dilute solutions.
4. With resins of high degrees of cross-linking, the ion having a smaller (hydrated) ionic volume is preferentially sorbed.
5. Organic ions may be sorbed by the hydrocarbon matrix of resins.

Complexing ion exchangers are distinguished from conventional ion exchangers by three main properties (20);

1. Selectivity. The affinity of a particular complexing resin for a particular metal ion depends mainly on the complexing ligand on the resin and on the size of the ion, its charge or other physical properties which determine the order of preference in the case of ordinary ion exchangers.
2. Bond strength. In ordinary ion exchangers, the Van der Waal forces are of the order of 2-3 kcal/mole while

in complexing resins the binding energy is on the order of 15-25 kcal/mole.

3. Kinetics. With conventional ion exchangers, the exchange process is rapid and is controlled by diffusion. The exchange process with complexing resins is slower and its rate is controlled either by a particle diffusion mechanism or by a second order chemical reaction. These differences open the door to the preparation and application of an unlimited number of selective sorbents which can be used for the concentration and separation of metal ions.

Determining the mechanism of metals binding to a complexing resin is a very complex problem. The ligands involved in the complex formation are fixed to a stationary matrix. This makes it necessary to take into account factors such as the spatial arrangement of the ligands on the matrix, the rigidity, the swelling properties and porosity of the matrix, and the inductive effects the matrix may have on the complexing ligand. These factors amplify the effects that factors such as pH and temperature have on the equilibrium.

B. Equilibrium

To gain a better understanding of the equilibrium taking place between metal ions in aqueous solution and a solid complexer, Lowenschuss and Schmuckler studied the properties

and behavior of the chelating ion exchanger Dowex A-1 (64). The stoichiometry of the reaction between the metal ions with Dowex A-1 was studied by measuring the maximum capacity of the resin using a known weight of dry resin in contact with increasing concentrations of copper(II), lead(II), iron(III) and thorium(IV). In all cases it was found that the metal ions were complexed to the iminodiacetic acid (IDAA) groups in a stoichiometric ratio of 1:1. This is different than the behavior of iminodiacetic acid in solution, where metal was combined with more than one molecule of IDAA, in accordance with their valency. From this it was concluded that the complexes in the resin are more stable than those formed in solution.

To study metal and ligand sorption by the resin, Lowenschuss and Schmuckler also studied the relation between the concentration of ligands in solution and the resin's adsorptive capacity for metal ions. In this study the ligand in solutions was IDAA.

The significant equilibria involved were as follows:

In Solution

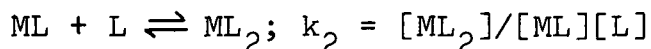

In Resin Phase



Over-all Reaction

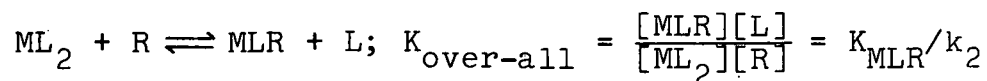

logarithmically

$$\log [L] = \log [ML_2][R]/[MLR] + \log K_{\text{over-all}}$$

where [MLR] = mmoles of metal present in resin

[L] = mmoles/100 ml of uncomplexed ligand

[ML₂] = mmoles/100 ml of metal complex remaining
in solution after phase separation

[R] = mmoles of functional group not bound to
the complexing metal ion

Plotting $\log [L]$ vs $\log [ML_2][R]/[MLR]$ then gives a straight line of unit slope whose intersection with the x-axis gives $K_{\text{over-all}}$. Values for k_2 can be found in the literature; K_{MLR} can then be determined. It was then concluded that the structure of the complex formed was

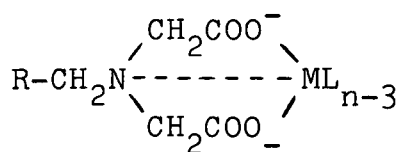

where n is the coordination number of the metal ion.

To determine a constant of the type K_{MR} , the resin must be brought into contact with a solution containing metal ions bound to a large polydentate ligand such as EDTA. Because of its bulkiness and stereospecificity, EDTA forms

metal complexes that will not enter the resin. Then only the hydrated metals alone can enter the resin.

In this system, the competing reactions are:

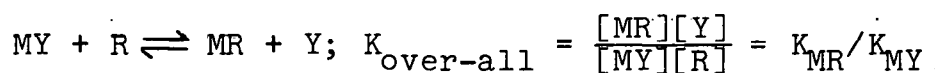

$$\log [R] = \log \frac{[MR][Y]}{[MY]} - \log K_{\text{over-all}}$$

K_{MR} can then be found by plotting $\log [R]$ vs $\log \frac{[MR][Y]}{[MY]}$

The conclusions from these studies were:

1. The stability constants of mixed complexes of the type MLR are higher than the sum of the stepwise complexation constants of the metals with the ligands in the solution.

2. The stability constants of complexes of the type MR are lower than those of the corresponding metals with HEDTA, but higher than the sum of the stability constants of the metals with IDAA in aqueous solution. The reason for this higher stability is that in aqueous solution binding to IDAA is accomplished in two steps, but in the resin, binding is accomplished in one step only.

When Dowex A-1 is in contact with trace quantities of metal ions, complexes of the ratio of one metal ion to two IDAA groups are formed, just as those formed between the

metals and iminodiacetic acid in solution. Hering determined the first constant of these complexes by potentiometric titrations for nickel and copper ions and found them to be very close to the first constant between iminodiacetic acid and these metals in solution (65).

Leyden and Underwood determined the apparent ionization constants of the iminodiacetic acid groups of Dowex A-1 by potentiometric titration of the resin with sodium hydroxide (66). The measured values were of the same order of magnitude as those of benzyliminodiacetic acid. However, the pH dependence of metal ion distribution coefficients were not predictable from the pK_a values of the monomeric chelates. With monomeric chelates the effective stability constant of a metal chelate increases with increasing pH, becoming maximal and equal to the absolute stability constant when the ligand is essentially completely ionized. For Dowex A-1 the maximum stability should occur around pH 10 or 11. However, it actually occurred at pH 4, which is in the region that the first ionization of Dowex A-1 became complete. They believed that this may have been because both ionogenic groups of Dowex A-1 are not involved in chelating metal ions. This is quite uncertain, however, since little is known about what is occurring within the pores of the resin.

C. Effect of Polymer Structure

The structure of the polymer which contains the selective functional groups plays a very important role in the formation of a bond between the metal ion and the functional group. In a review by Saldadze and Kopylova the dependence of complex formation on the nature of the resin was discussed at length (67). They discussed how monomeric chelates form complexes with coordination numbers of six and four, whereas with a resin the insolubility and low mobility of the highly cross-linked macromolecular skeleton impedes the formation of complexes whose stereochemistry is determined by the media. This often results in the formation of complexes which have lower stability constants than those of monomeric ligands.

Saturation of the coordination sphere of a metal ion by the functional groups of the resin depends on the nature of the coordination sphere, the structure of the monomer unit, the concentration and regularity with which the groups are arranged along the polymer, and the flexibility of the macromolecular skeleton. As the polymer chain approaches the ligand group, the complex-forming properties of the resin decrease because of the limitations placed on the mobility of the ligand and because of steric hindrance. More stable complexes can be formed when there are comparatively small gaps between the ligand groups and they have regular repetition. In this way cyclic structures involving the

metal ions can be formed, the saturation of the coordination sphere of the metal becomes greater and the stability of the complex increases. When a metal ion diffuses into a resin, ligand groups from adjacent polymer chains come within the coordination sphere of the metal ion. The ligand groups are not all in the most favorable configuration for forming a complex and therefore a shift in conformation of the polymer chains is required. This change in conformation is accompanied by an expenditure of energy. The less flexible the polymer chain, the greater the amount of energy expended. Because the coordination energy of the metal ion and the ligands is constant, the stability of the polymer complexes is related directly to the deformation energy, which is a result of the rigidity of the macromolecular skeleton. This means that as the percentage cross-linking increases in the resin, the electron-donor properties of the ligand groups decrease and therefore the stability constants of the resin complexes decrease. These conclusions were made about gel-type resins, and no mention was made of macropous resins.

The homogeneity of the functional groups in the resin phase also play an important role in complex formation. When a resin contains only one type of ligand group, the complexes formed differ only in the number of resin ligand groups coordinated to each metal ion. This difference can make a large difference in the stability of the ligand-ion

complex and can significantly effect the separation of metal ions.

Kopylova, Saldadze and Makvabishvili used infrared-spectroscopic and potentiometric methods to study the complex formation occurring between transition metals and a phosphoric acid resin cross-linked with various amounts of divinyl benzene and a similar resin with varying porosity (68). They showed that the stability constants of the polymer complexes decreased with both an increase in cross-linking and porosity of the resin. However, the effect of the porosity was much less than that of the cross-linking.

Moyers studied the effect of pore size and surface area of macroporous polystyrene-divinyl benzene copolymers on the synthetic yield and kinetics of arsonic acid resins prepared from these polymers (45). Both the yield and kinetics appeared to depend on pore size and surface area. The resins prepared from matrices with largest pore size and large area gave the best yields. The resins prepared from matrices with large surface area and small pore size complexed with metal ions most rapidly.

Resins prepared by condensation usually have a low capacity and slow kinetics and in some cases are both mechanically and chemically unstable. The complexing properties of these resins are often inferior to those of the corresponding monomeric reagents, because the functional

groups of the monomer have been involved in the condensation and also because of steric hinderance which develops during complex formation between the elements and cross-linked resins (24). The early styrene-divinylbenzene copolymers were also inferior because of swelling problems which makes them inadequate for column work, and causes damage to the matrix (69).

Vernon and Eccles concluded that although modern highly cross-linked macroporous polymers are very sterically hindered, they do have advantages over resins prepared on other matrices and by polycondensation (70). They compared four different 8-hydroxyquinoline resins and found that those prepared from the macroporous Amberlite XAD-2 had lower capacities than those prepared by condensation. However, for column work, XAD-2 was superior because of its much faster rate of equilibration with metal ions.

D. Effect of Solution Medium

One final factor which affects the formation of a complex between a metal ion and the ligands on a resin is the composition of the solution medium. It was shown by Schmuckler that there is competition between ligands in solution and the resin ligands for a particular metal ion (71). This means that there are "conditional capacities" for metal complexes with a resin just as there are conditional stability constants of metal ions in solution.

Kopylova et al. studied the effect of the ionic composition of the solution medium on the sorption of cations by polyethylene-polyamine ion-exchange resins (72). The possibility of formation of coordination compounds with this resin depends primarily on the state of the amino groups of the resin. The amino groups can exist in the salt form ($R_3NH^+An^-$) and the hydrated form ($R_3N \cdots HOH$). The salt form does not form coordination compounds with metals since the nitrogen-hydrogen bond is stronger than the nitrogen-metal bond. Therefore, any change in the ionic composition of the resin which results in an increase of its content of amino-groups in the hydrated form should increase the capacity of the resin for cations.

To study the effects of ionic composition of the resin on its sorption of cations, the hydrated form of the resin was treated with different volumes of 0.1 N nitric acid, washed with water, air dried and equilibrated with a 0.1 N copper nitrate solution at pH 4.3. An increase in the amount of amino groups in the hydrated form led to an increase in the degree of sorption of copper. However, this was observed only up to a certain limit above which the degree of sorption depended on both complex formation and formation of precipitates. The optimum ionic composition of the resin for complex formation depends mainly on the nature of the cation sorbed. The greater the stability of the complex and the

lower the pH of formation of the hydroxide, the higher the number of amino groups in the hydrated form for optimum sorption.

From the discussion of the effects of the nature of the resin on complex formation, it appears that the best resin would be one with high capacity, flexible functional groups, fast kinetics and a matrix that is very stable. A polymer with all of these properties has not yet been made, however, Amberlite XAD-4 does have some of these properties and was used for the preparation of the resins in this work.

Although the XAD-4 matrix is highly cross-linked and resins of very high capacity cannot be prepared, it does have fast kinetics, is very stable and appears to be the best compromise for column work.

IV. N,N-DIBUTYL AMIDE RESIN FOR THE CONCENTRATION AND SEPARATION OF METAL IONS

A. Apparatus and Reagents

The liquid chromatograph (Figure 1) has been previously described (73,74) and modified (75).

A Cary 16 spectrophotometer was used to measure the absorbance of samples determined by conventional spectrophotometric methods.

Zirconium solutions were prepared from hafnium-free $ZrOCl_2 \cdot 8 H_2O$ prepared at the Ames Laboratory of the Energy Research and Development Administration. All other solutions of metal ions were prepared from reagent grade metal salts.

Dibutylamine, m.p. 156-158 °C, was purchased from Eastman Organic Chemicals. 4-Chlorobutyryl chloride, b.p. 173-174 °C, n_D^{20} 1.4609, d 1.258, was purchased from Aldrich Chemical Company. 3-(2-Aminoethylamino)propyltrimethoxysilane, b.p. 146°C/15 mm, n_D^{25} 1.4418, was purchased from PCR Incorporated.

The Amberlite XAD-4 resin was supplied by Rohm and Haas Company. The resin was Soxhlet extracted with methanol, ground, and sieved before use. Porasil A and Porasil C were supplied by Waters Associates.

The color-forming reagent chosen for the chromatographic determination of uranium(VI), thorium(IV), zirconium(IV) and

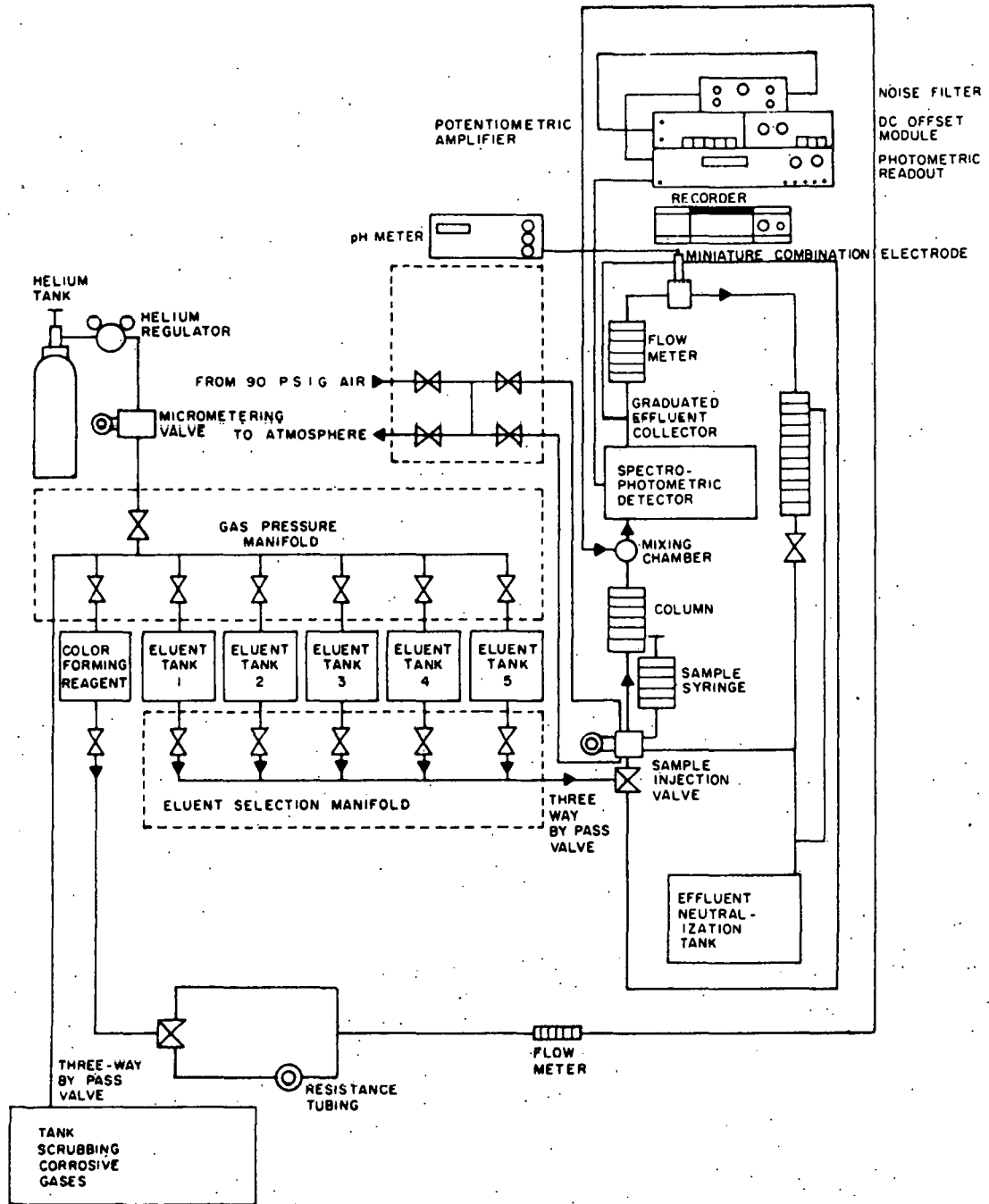

Figure 1. Schematic diagram of forced-flow chromatograph

the rare earth metals was Arsenazo III (1,8-dihydroxy-naphthalene-3,6-disulfonic acid-2,7-bis((azo-2-phenylarsonic acid)) at pH 0.5 (76). Experiments were performed where Arsenazo I, Arsenazo III and PAR were tested as color-forming reagents for uranium, thorium and zirconium ions in the presence of several different anions and at several different pH values. All of the reagents were affected by large amounts of salts, but Arsenazo III at very low pH was the best choice of the reagents examined.

PAR (4-(2-pyridylazo)resorcinol) was used for the chromatographic determination of iron(III), zinc(II), nickel(II), cobalt(II), cadmium(II), manganese(II), lead(II) and copper(II) (77).

Arsenazo I (3-(2-arsonophenylazo)-4,5-dihydroxy-2,7-naphthalene-disulfonic acid) was used for the determination of uranium in the capacity studies (78).

B. Synthesis and Characterization

Several attempts were made to synthesize an amide resin with the highest capacity for uranium and one on which separations of uranium, thorium and zirconium could be performed. The first attempts were made with silica based matrices. The synthesis of these resins were based on the following reactions:

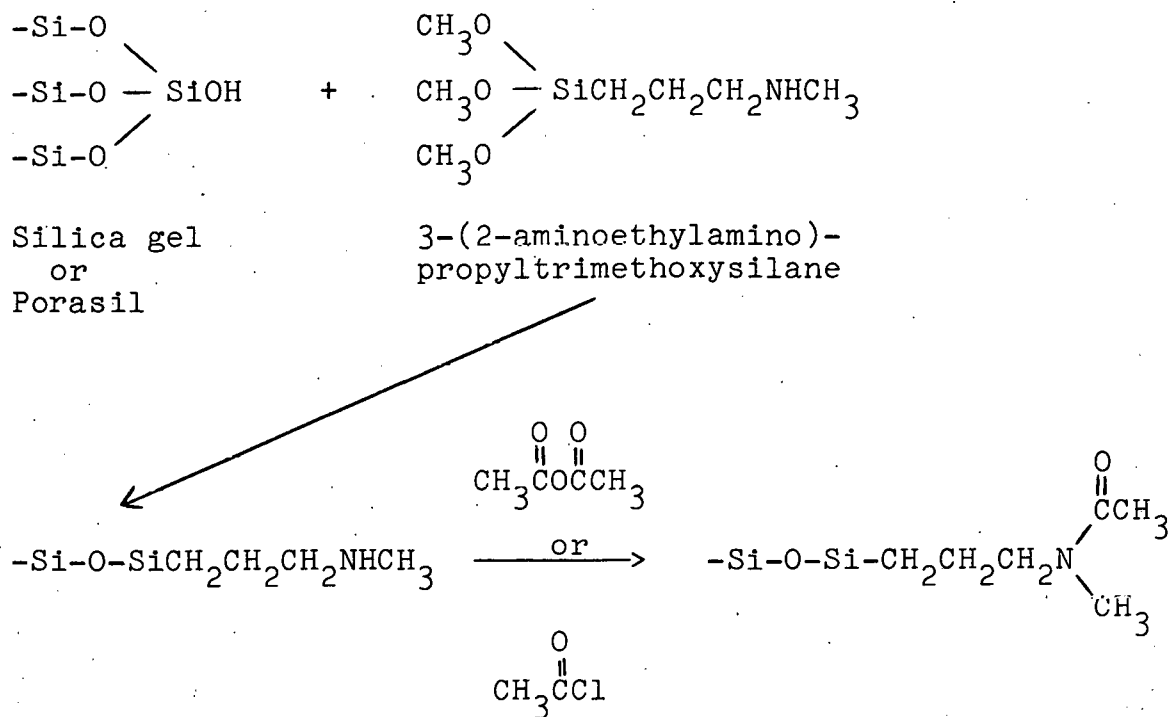

Activation of the silica before silylation was necessary to obtain products with the highest capacity for uranium. This was accomplished by refluxing the silica in concentrated hydrochloric acid for 4 hours, washing with water and drying at 120°C. This was to assure that all hydroxyl groups on the gel were free to react with the silane. The silylation step was performed in two ways. One was to stir the silica with a 10% aqueous solution of the silylation reagent adjusted to pH 4.0 (12). The other method was to reflux the silica with the silylation reagent in toluene. The toluene method gave the products with the highest yield. The acetylation

procedure was performed with both acetic anhydride and acetyl chloride, with and without addition of small amounts of sodium acetate. The use of the anhydride or acid chloride did not have much effect on the product, but the addition of sodium acetate did give better yields. Resins prepared from silica gel gave higher yields than those prepared from Porasil. Complete deactivation of the active sites remaining on the final products was attempted by stirring the resin in a solution of trimethylchlorosilane.

The resins prepared on silica matrices did not prove to be very useful for good separations of uranium, thorium and zirconium so three different resins were prepared with Amberlite XAD-4 matrices. The first two modified resins were prepared as follows:

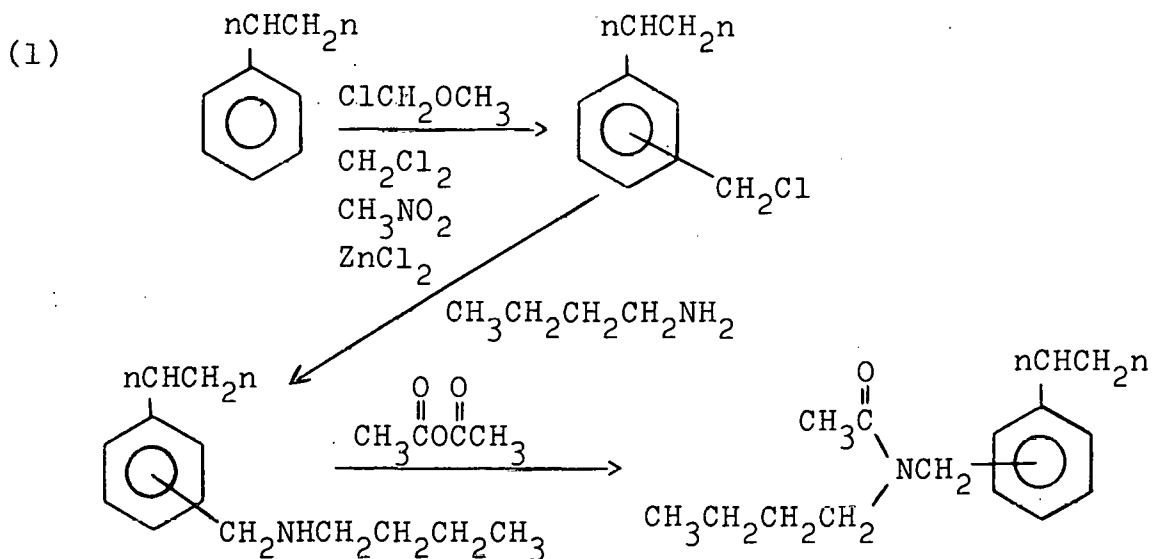

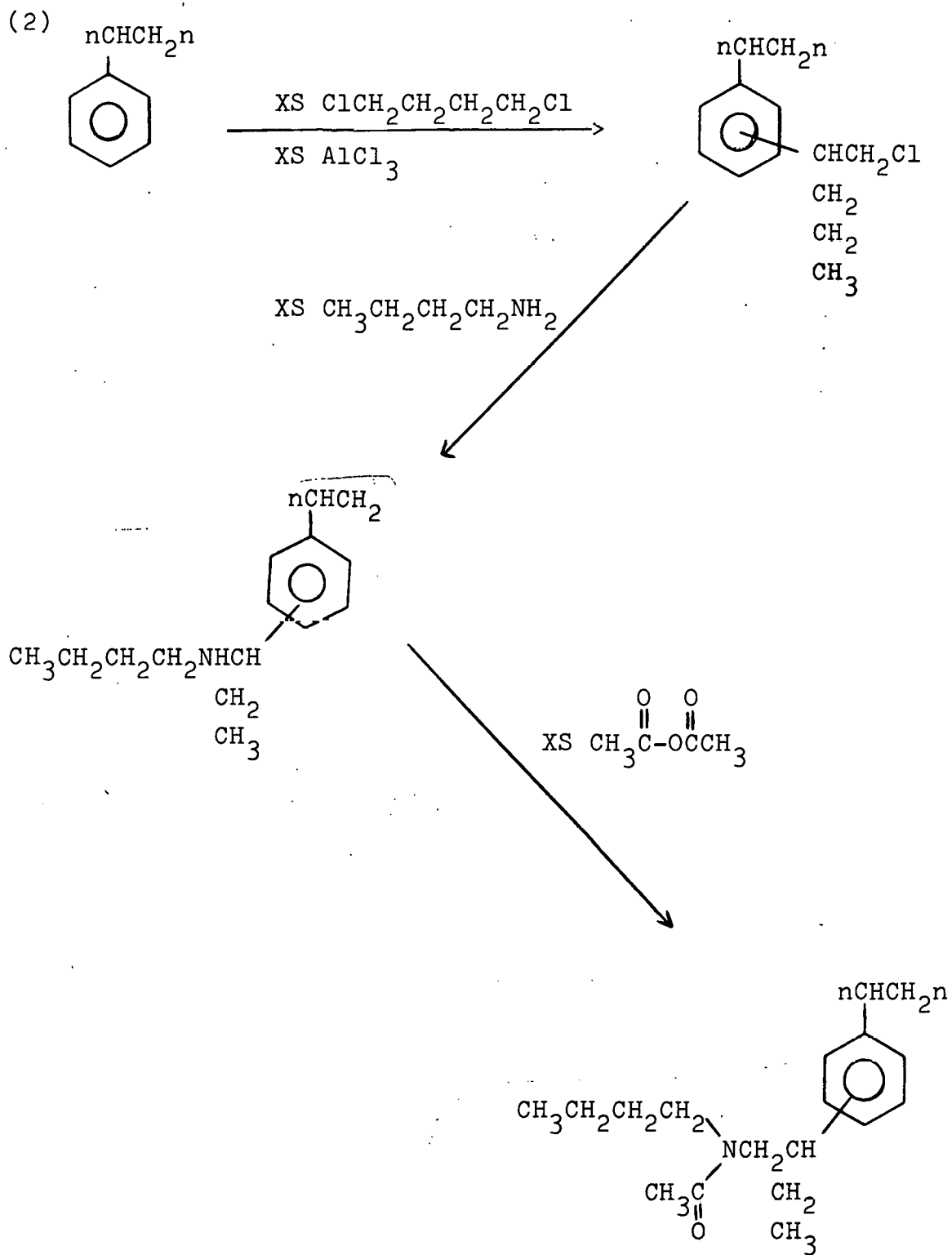

The third modified XAD resin, the one used for the present work, was prepared by the following sequence of reactions:

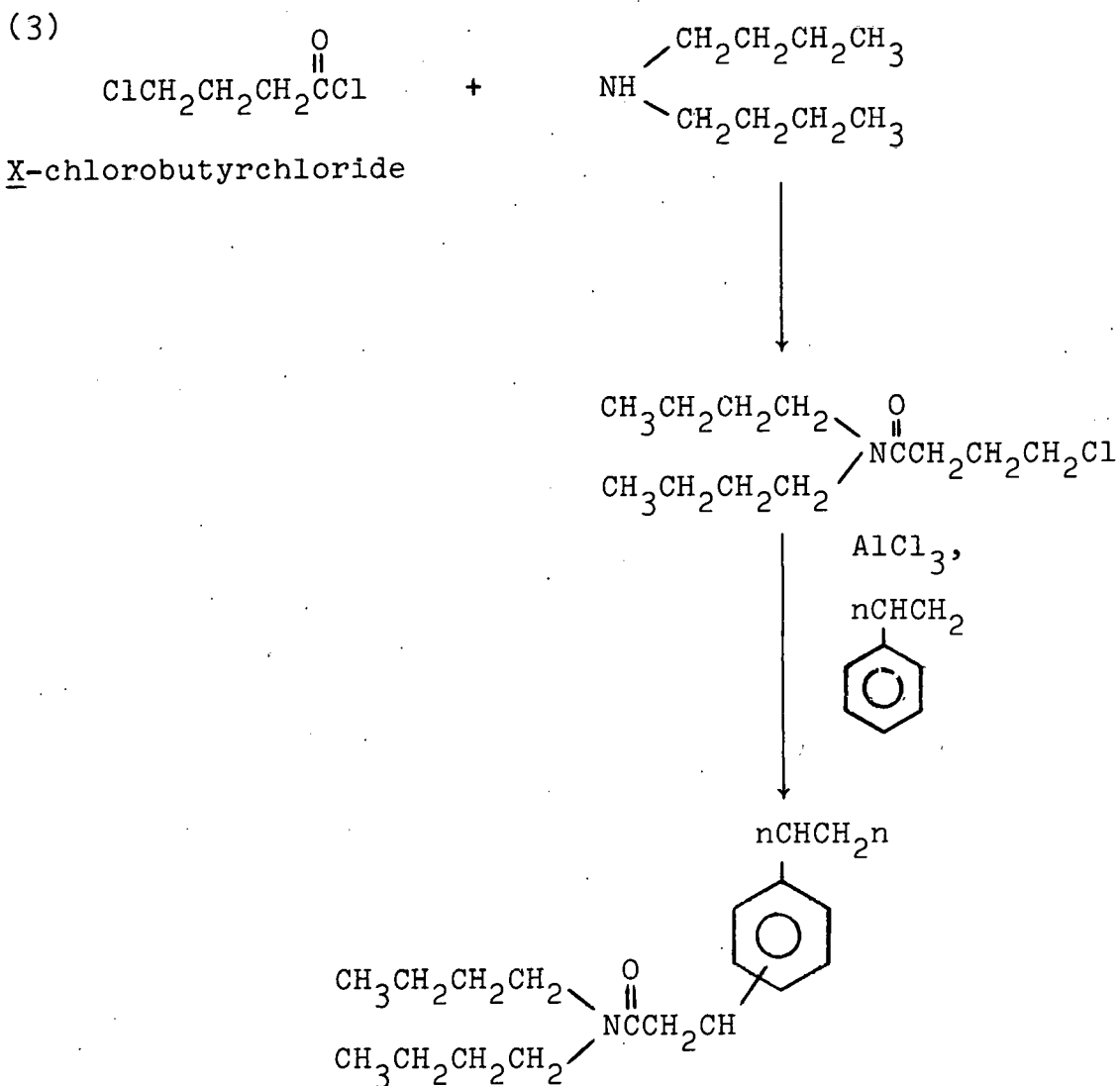

The first product of the synthesis was prepared as described by Falbe, Paatz and Korte (79). This was accomplished by stirring 28 ml of γ -chlorobutyrylchloride into a solution of 84 ml of dibutylamine in 150 ml of petroleum ether which had been cooled in an ice bath. The reaction mixture was stirred for two hours in the ice bath and then allowed to stand overnight. The salt was then filtered off and washed with petroleum ether. The ether was distilled from the product by rotovaporization and the product was purified by vacuum distillation at 150°C and 0.001 mm Hg. The IR and NMR spectra (Figure 2 and Figure 3) confirm the structure of the first product.

The final product was prepared by slowly adding 15 ml of the first product to a mixture of 9 g of XAD-4 which had been dried in a vacuum at 120°C for 24 hrs, 21 g of anhydrous aluminum chloride and 200 ml of carbon disulfide. The reaction mixture was then poured into an ice bath and the resin was finally filtered and washed with dilute hydrochloric acid and acetone. The presence of an amide group on the resin was confirmed by an IR spectra of the final product (Figure 4).

The nitrogen content of the resin was determined by the Dumas method (80). This showed the resin to contain 2.88% nitrogen, which indicates 2.05 meq of amide functional group per gram of resin.

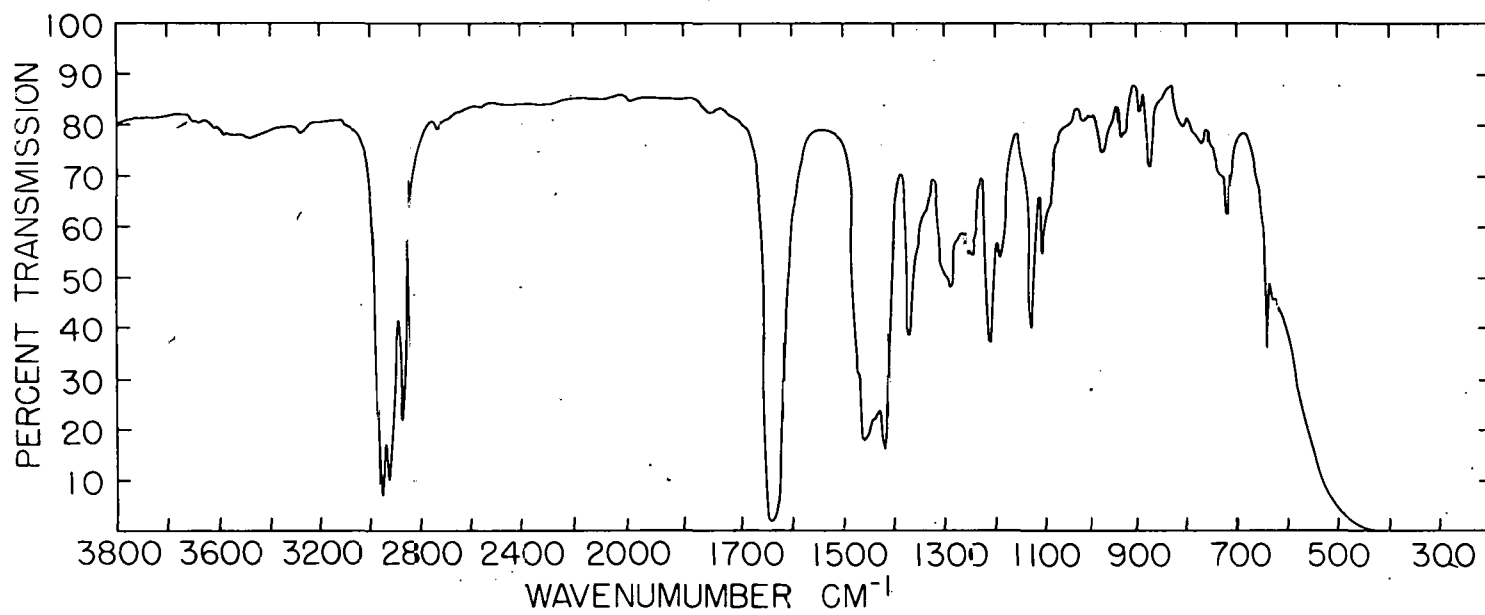

Figure 2. Infrared spectrum of first product of amide resin synthesis

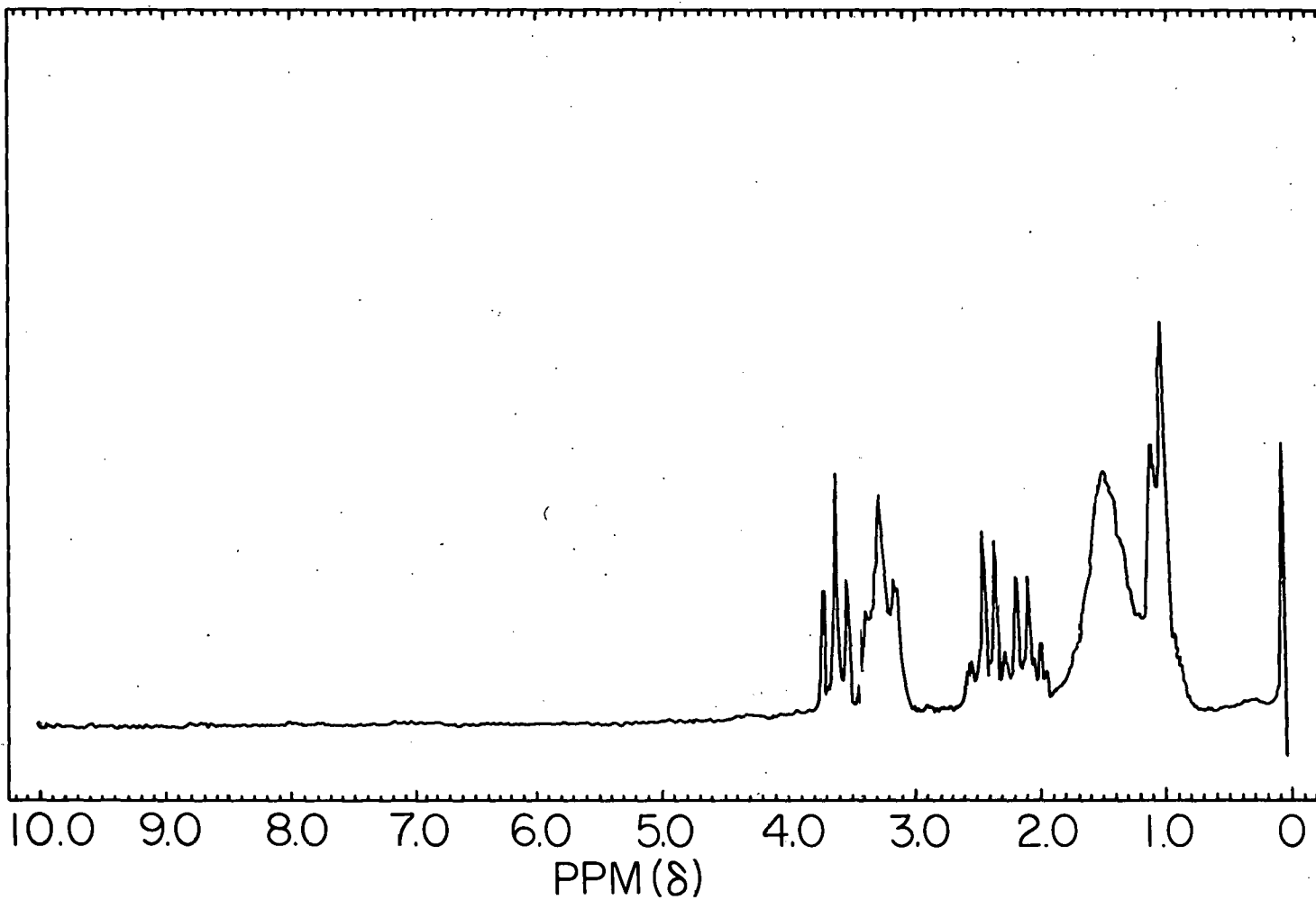

Figure 3. NMR spectrum of first product of amide resin synthesis

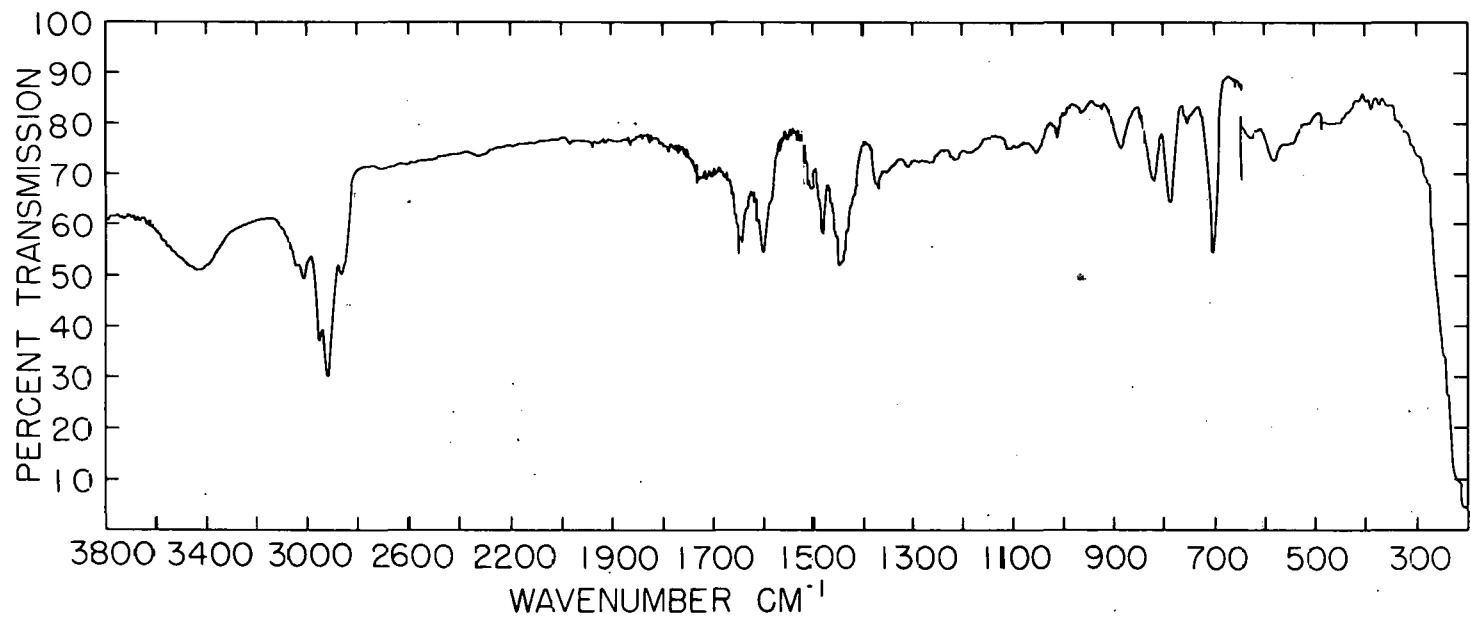

Figure 4. Infrared spectrum of amide resin

C. Sorption Properties of Amide

Resins Prepared

Attempts to separate uranium(VI), thorium(IV) and zirconium(IV) on the silica based resins were not very successful. All three metal ions were retained by the resin at pH values greater than 4.0 when nitrate or perchlorate salts were present in high concentrations. However, the metal ions could not be eluted from the resin cleanly, apparently because they were being held on this resin by two different mechanisms. For example, when uranyl ion was retained on the resin from 2 M sodium nitrate solution, part of the uranium could be eluted with 0.05 M HEDTA while the rest required 10^{-3} M hydrochloric acid. This was believed to be due to unreacted hydroxyl groups on the silica gel that were complexing with the metal ions in addition to the metal complexes with the amide functional groups. Attempts to deactivate the resin completely with trimethylchlorosilane improved the separations some, but quantitative results could not be obtained.

The work with the silica based resins indicated that metal ions were being retained by the amide functional groups. However, the presence of unreacted hydroxyl groups on the silica matrix made quantitative separations impossible. Therefore, amide resins were prepared on a matrix that

contained no active ion exchange sites. Amberlite XAD-4 was the matrix chosen.

The first XAD resin retained uranium(VI), thorium(IV) and zirconium(IV) from sodium nitrate or sodium perchlorate solutions that were 2.0 M or greater but reduction of the salt concentration or addition of complexing reagents to the solution caused all three ions to be eluted.

The problems with this resin were believed to be caused by the structure of the amide group. Solvent extraction studies had shown that N,N-dibutylacetamide was the best reagent for the extraction of uranium and thorium. Therefore, an attempt was made to prepare a second resin with a structure similar to N,N-dibutylacetamide.

The problems with this resin were the same as with the previous one. The problems were believed to be caused by the synthetic route used in its preparation. The major problem may have been caused by cross-linking of the 1,4-dichlorobutane molecules between the phenyl groups of the resin. This causes lower capacity and greater steric hindrance for complexation. Also, with this resin and the previous one, three different reactions were performed on the XAD-4 matrix before the final product was obtained. Since the polymer cannot be purified after each reaction there is the possibility of undesirable functional groups on the final product. Also, with each reaction taking place on

the macroporous matrix, some of the pores become plugged with reagent. This lowers the capacity of the final product.

The final amide resin was prepared by synthesizing a chlorinated amide that could be purified by distillation and then bonded to the resin matrix in one step by a Friedel-Crafts alkylation. With this resin it was then possible to make clean separations without interference from other groups bonded to the resin. A summary of the retention of uranium(VI), thorium(IV) and zirconium(IV) ions from eluents containing varying amounts of salting out agents, complexers and acids is shown in Table 2. These data indicate that all three metal ions could be retained from pH 3 perchloric acid, pH 3 hydrochloric acid or dilute acid containing a high concentration of salt. Perchloric acid was chosen as the eluent for work on the separation of the ions. The metal ions were retained more strongly from a noncomplexing acid such as perchloric acid than with a complexing acid such as hydrochloric acid. Also, making separations using only differences in retention due to pH were chosen over the use of salting out agents and complexing agents because this would minimize interferences in the detection of the ions.

Table 2. Retention of uranium, thorium and zirconium by dibutyl amide resin

Eluent	UO ₂ ²⁺	Th ⁴⁺	ZrO ²⁺
1 M NaNO ₃ + 10 ⁻³ M HNO ₃	retained	eluted in sharp band	retained
1 M NaNO ₃ + 10 ⁻² M HNO ₃	eluted in broad band	tailed badly	tailed badly
HNO ₃ pH 1	eluted in sharp band	some tailing	some tailing
1 M NaNO ₃ + 10 ⁻³ M HCl	retained	retained	retained
1 M NaNO ₃ + 10 ⁻² M HCl	eluted in broad band	tailed badly	tailed badly
1 M NaNO ₃ + 10 ⁻¹ M HCl	eluted in sharp band	eluted in sharp band	tailed badly
HCl pH 3	begins to tail after long period	retained	retained
HCl pH 2	eluted in sharp band	eluted in sharp band	eluted in sharp band
1 M NaNO ₃ + 10 ⁻² M H ₂ SO ₄	eluted in sharp band	eluted in sharp band	eluted in sharp band
1 M NaNO ₃ + 10 ⁻² M HClO ₄	eluted in broad band	tailed badly	retained
1 M NaNO ₃ + 10 ⁻³ M EDTA	retained	tailed badly	tailed badly

Table 2. (Continued)

Eluent	UO ₂ ²⁺	Th ⁴⁺	ZrO ²⁺
0.5 M NaNO ₃ + 2.5 x 10 ⁻² M EDTA	tailed badly	eluted in sharp	tailed badly
HClO ₄ pH 3	retained	retained	retained
HClO ₄ pH 2.5	eluted in sharp band	retained	retained
HClO ₄ pH 2.0	eluted in sharp band	retained	retained
HClO ₄ pH 1.5	eluted in sharp band	eluted in sharp band	retained
HClO ₄ pH 1.0	eluted in sharp band	eluted in sharp band	retained
HClO ₄ pH 0.5	eluted in sharp band	eluted in sharp band	retained

The retention of several other metal ions from pH 3 perchloric acid were then studied. The results are summarized in Table 3.

Table 3. Retention of various heavy metals by dibutyl amide resin

Metal ion	Indicator	Retention
Cu^{2+}	PAR	None
Ni^{2+}	PAR	None
Co^{2+}	PAR	None
Pb^{2+}	PAR	None
Zn^{2+}	PAR	None
Hg^{2+}	HCl	None
Sn^{2+}	HCl	Hydrolyzed
Fe^{3+}	HCl	None
Ce, Gd, Dy, Lu	Arsenazo III	Tailed badly

D. Separation Scheme

The method chosen for the separation of uranium, thorium and zirconium from each other and from several other heavy metals was as follows: A sample containing uranium, thorium,

zirconium and foreign ions is injected into an eluent stream of pH 3 perchloric acid. Under these conditions most foreign ions are eluted and the three ions of interest are retained. The uranium is then eluted with pH 2 perchloric acid, the thorium is eluted with pH 0.5 perchloric acid and the zirconium is eluted with 1 M sulfuric acid. Zirconium could be eluted with any mineral acid with a concentration of 1 M or greater, but the sharpest elution was obtained with sulfuric acid.

Separations of standard solutions of uranium, thorium and zirconium of various concentrations gave linear calibration curves for uranium and thorium. However, zirconium could not be determined quantitatively. The reason for this is not certain, but it could possibly be due to polymerization of the ion or it could be from an interference in the eluent which prevents quantitative complexation of the zirconium with the dye. There is also the possibility of partial hydrolysis of zirconium at pH 3. The separation of uranium, thorium and zirconium by the method described above is shown in Figure 5.

E. Interference Studies

To study the effect of large excesses of foreign ions on the determination of uranium and thorium, the two metals were determined in the presence of 20-fold excesses of several

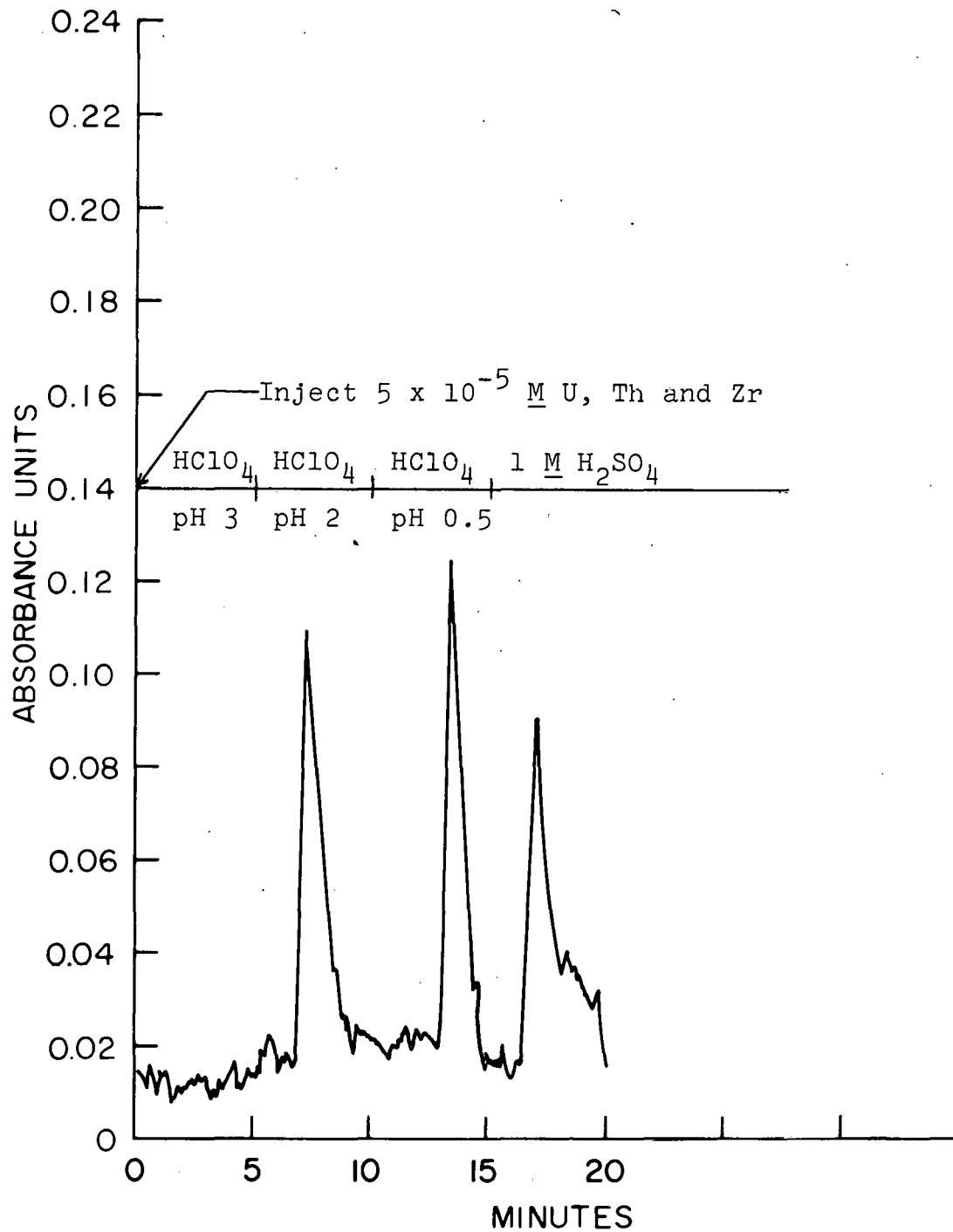

Figure 5. Separation of $5 \times 10^{-5} \text{ M}$ uranium(VI), thorium(IV) and zirconium(IV)

metal ions and anions and 200-fold excesses of some complexing anions. The recovery of uranium and thorium in the presence of these potential interfering ions are shown in Tables 4 and 5. Figures 6 through 16 show chromatograms of several of the interference studies. All of the separations performed on the amide resin were with a 6 cm x 6 mm column. The eluent flow rate was 1.2 ml/min, the dye flow rate 0.8 ml/min, and the sample loop was 54 μ l.

These studies show the separation of uranium(VI) and of thorium(IV) to be quite selective. Rare earths are the major cationic interferences. At pH 3.0 the rare earths tail so badly that their separation from uranium is not possible. At pH 2.0 rare earths elute more rapidly, although there is still some tailing. Thorium can be separated from rare earths at pH 2.0 with subsequent elution of thorium at pH 0.5, but the recoveries of thorium are still somewhat low.

Large excesses of tin(IV) also interfere with the separation and determination of uranium and thorium. This is probably due to hydrolysis of tin at pH 3.0 during the separation. Addition of tartrate to complex the tin increased the recovery of uranium from 81% to 94%.

A large excess of tartrate causes slightly low results and excess citrate causes quite low recoveries of uranium and thorium. This could be caused by repression of the

Table 4. Determination of uranium in the presence of foreign ions

Foreign ions	% Recovery (Avg. of two trials)
10^{-3} <u>M</u> Fe^{3+} , Al^{3+} and Co^{2+}	99.1
10^{-3} <u>M</u> Mg^{2+} , Pb^{2+} and Ni^{2+}	99.5
10^{-3} <u>M</u> Zn^{2+} , Cu^{2+} and Cd^{2+}	99.5
10^{-3} <u>M</u> V^{5+} , 5×10^{-5} <u>M</u> Th^{4+} and Zr^{4+}	100.0
10^{-3} <u>M</u> Sn^{2+}	81.4
10^{-3} <u>M</u> Hg^{2+} , 5×10^{-5} <u>M</u> Th^{4+} and Zr^{4+}	99.0
10^{-3} <u>M</u> Sn^{2+} + 10^{-3} <u>M</u> tartrate	94.0
10^{-3} <u>M</u> NO_3^- , 5×10^{-5} <u>M</u> Th^{4+} and Zr^{4+}	97.9
10^{-3} <u>M</u> Cl^- , 5×10^{-5} <u>M</u> Th^{4+} and Zr^{4+}	100.0
10^{-3} <u>M</u> SO_4^{2-} , 5×10^{-5} <u>M</u> Th^{4+} and Zr^{4+}	99.4
10^{-2} <u>M</u> tartrate	91.5
10^{-2} <u>M</u> citrate	76.0
10^{-2} <u>M</u> phosphate	99.2
10^{-3} <u>M</u> Ho^{3+}	not reproducible
10^{-3} <u>M</u> Ce^{4+}	not reproducible
10^{-3} <u>M</u> Gd^{3+}	not reproducible
10^{-4} <u>M</u> Ce^{4+}	not reproducible

Table 5. Determination of thorium in the presence of foreign ions

Foreign ions	% Recovery (Avg. of two trials)
10^{-3} <u>M</u> Fe, Al, Co, 5×10^{-5} <u>M</u> U and Zr	97.2
10^{-3} <u>M</u> Mg, Pb, Ni, 5×10^{-5} <u>M</u> U and Zr	99.4
10^{-3} <u>M</u> Zn, Cu, Cd, 5×10^{-5} <u>M</u> U and Zr	98.9
10^{-2} <u>M</u> tartrate, 5×10^{-5} <u>M</u> U and Zr	94.6
10^{-2} <u>M</u> citrate, 5×10^{-5} <u>M</u> U and Zr	85.6
10^{-2} <u>M</u> phosphate, 5×10^{-5} <u>M</u> U and Zr	0
10^{-3} <u>M</u> Ho, 5×10^{-5} <u>M</u> U and Zr	83.3
10^{-3} <u>M</u> Ce, 5×10^{-5} <u>M</u> U and Zr	90.7
10^{-3} <u>M</u> Gd, 5×10^{-5} <u>M</u> U and Zr	92.6
10^{-3} <u>M</u> V, 5×10^{-5} <u>M</u> U and Zr	97.2
10^{-3} <u>M</u> Sn, 5×10^{-5} <u>M</u> U and Zr	77.6
10^{-3} <u>M</u> Hg, 10^{-5} <u>M</u> U and Zr	100.0
10^{-3} <u>M</u> sulfate, 5×10^{-5} <u>M</u> U and Zr	127.0
10^{-3} <u>M</u> nitrate, 5×10^{-5} <u>M</u> U and Zr	104.0
10^{-3} <u>M</u> chloride, 5×10^{-5} <u>M</u> U and Zr	98.2

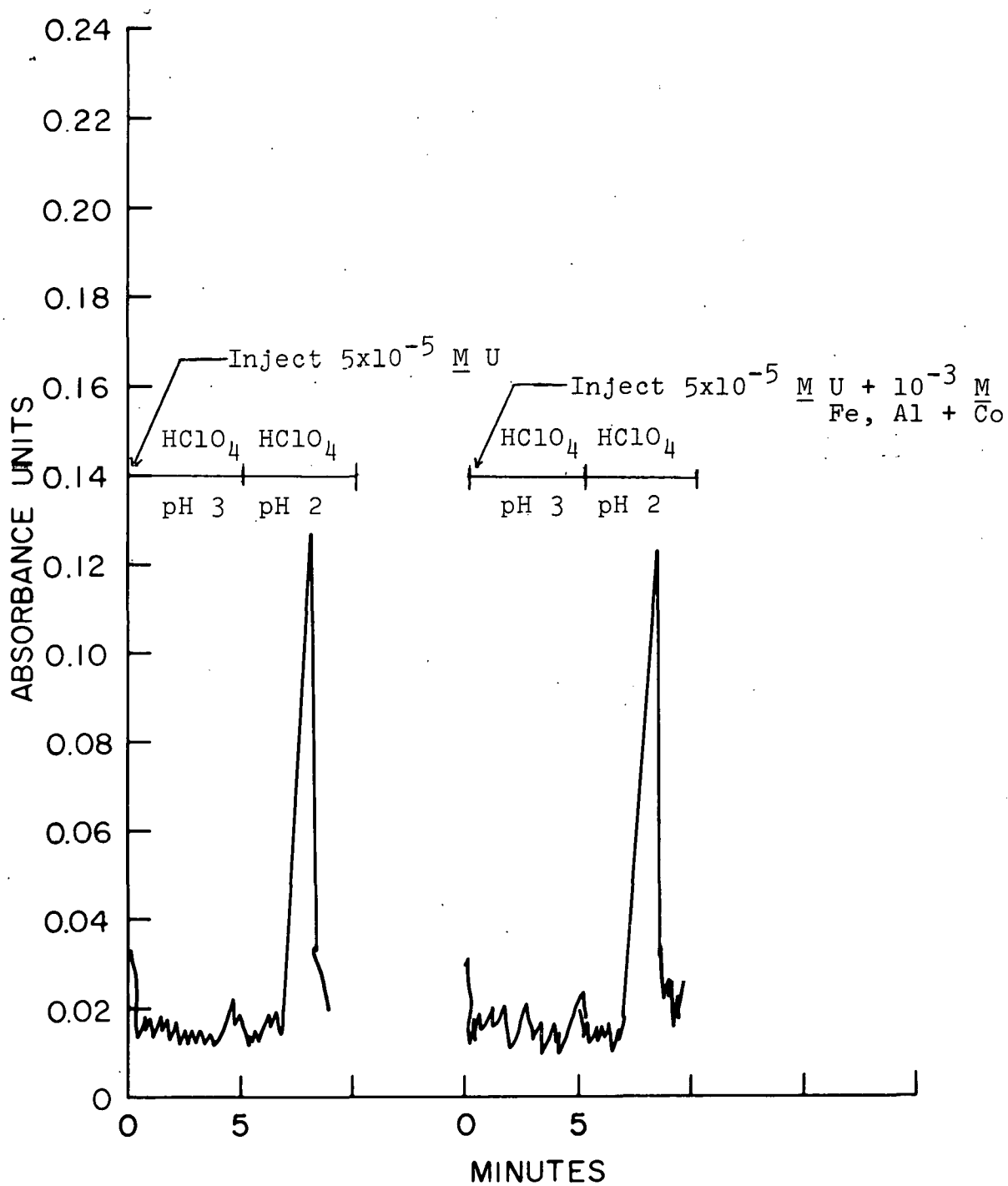

Figure 6. Determination of uranium in the presence of iron, aluminum and cobalt

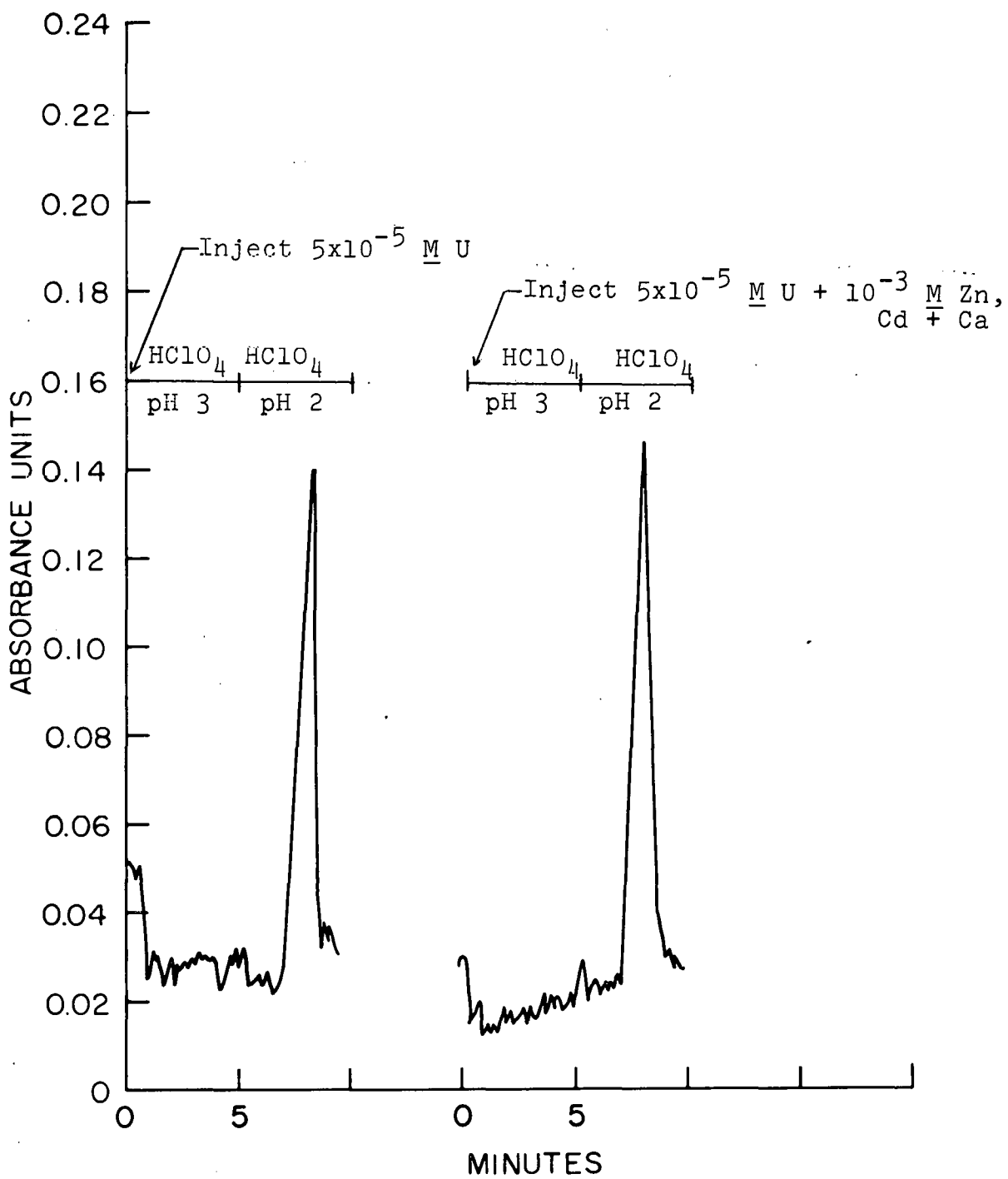

Figure 7. Determination of uranium in the presence of zinc, cadmium and copper

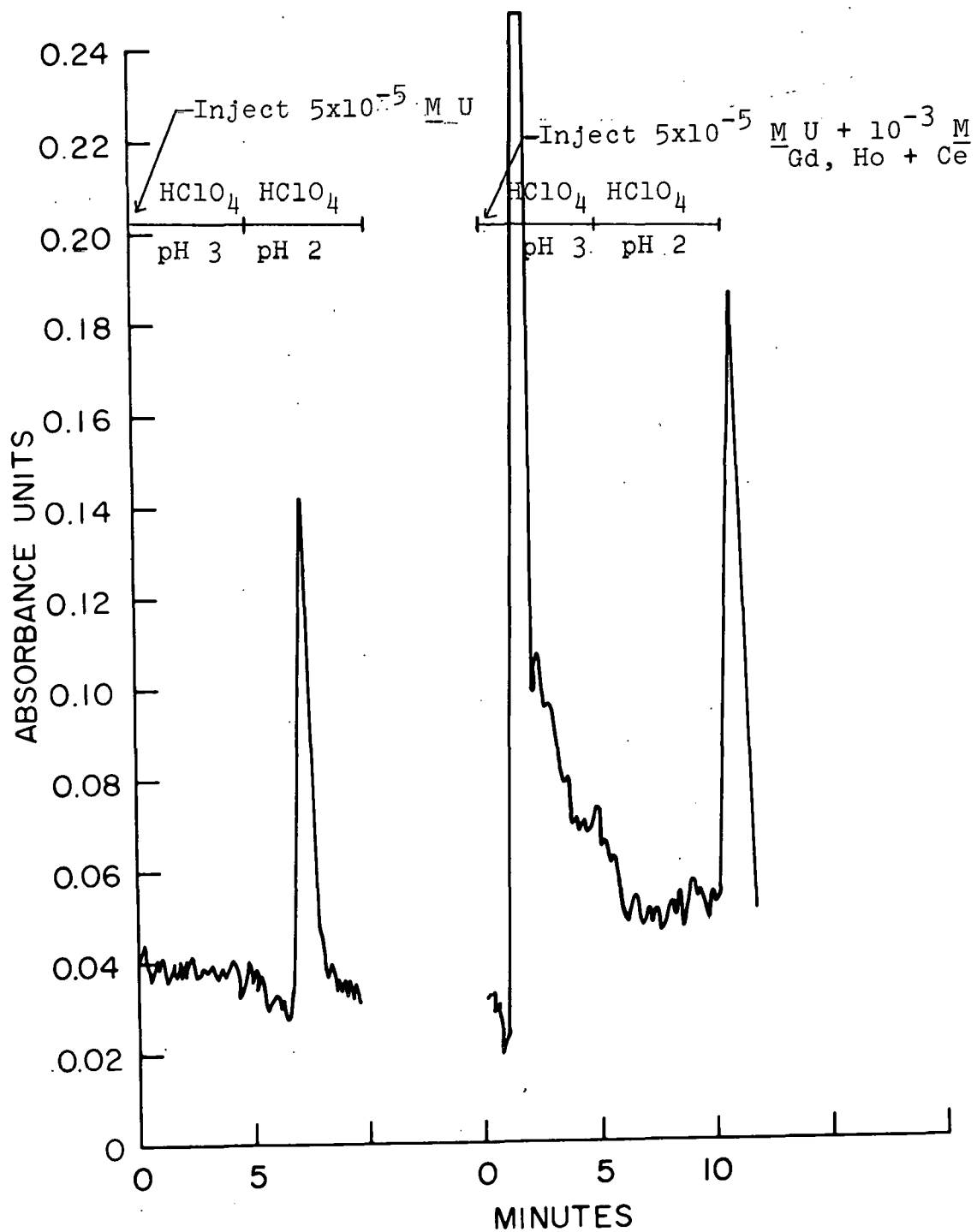

Figure 8. Determination of uranium in the presence of cerium, holmium and gadolinium

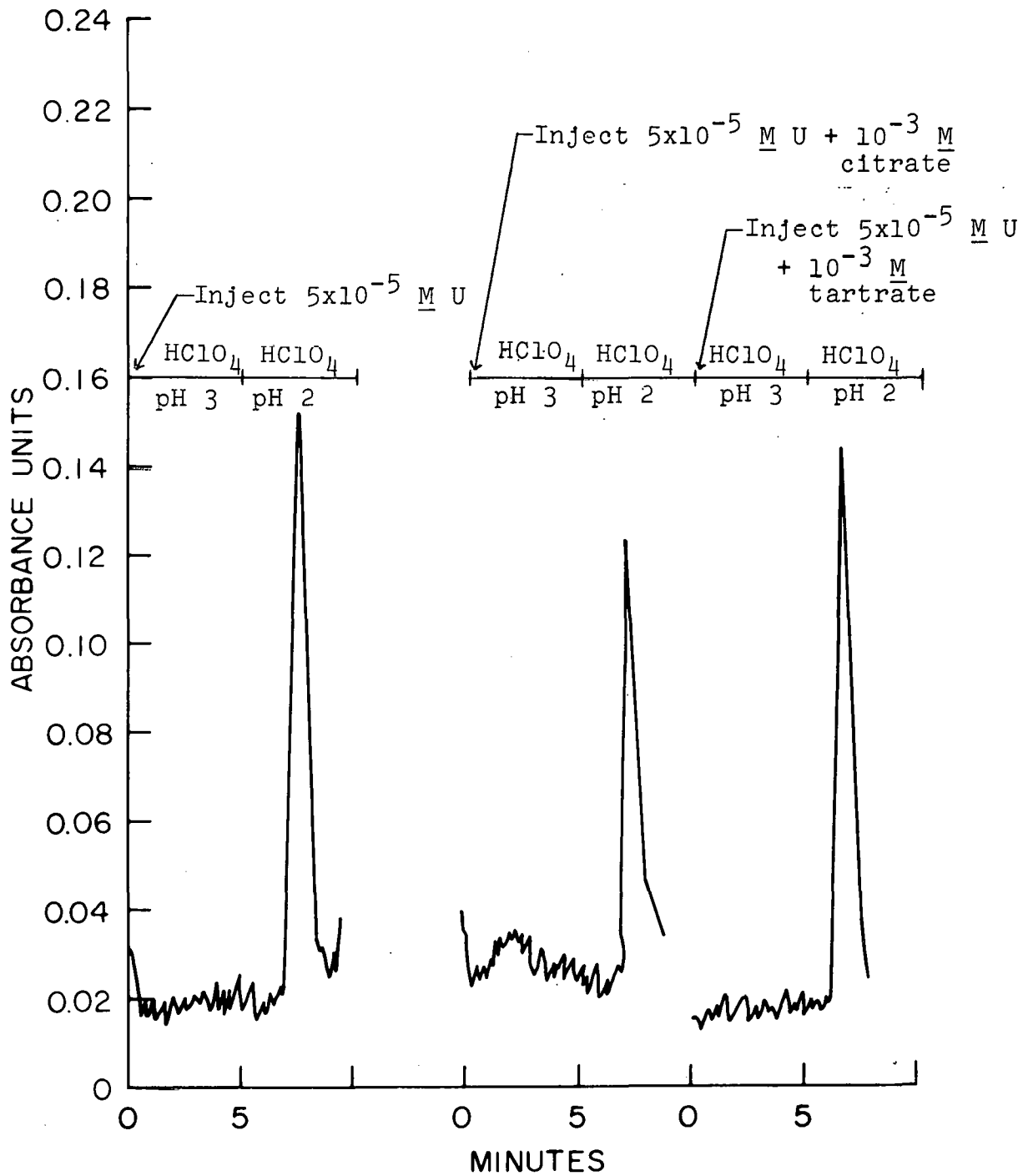

Figure 9. Determination of uranium in the presence of citrate and in the presence of tartrate

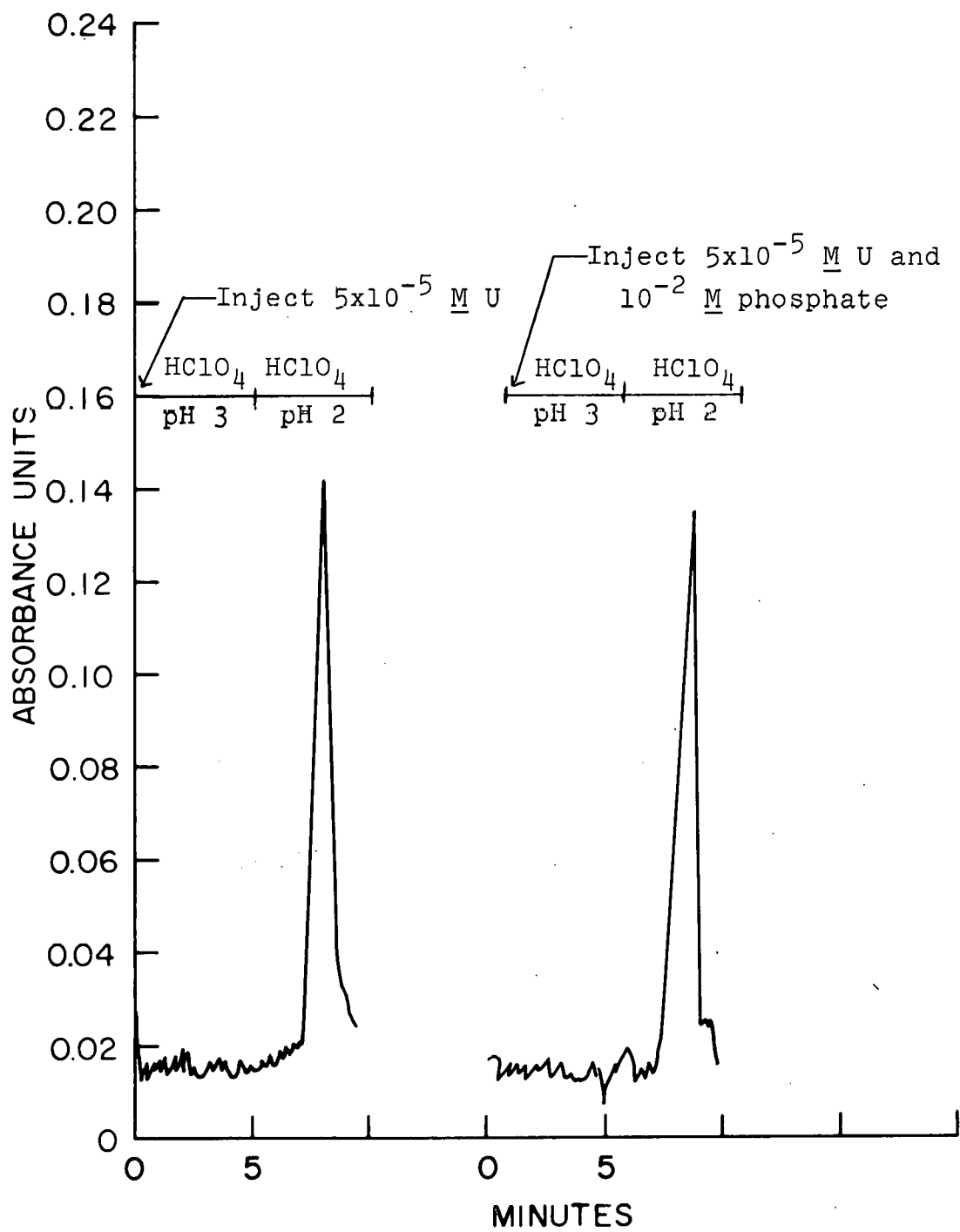

Figure 10. Determination of uranium in the presence of phosphate

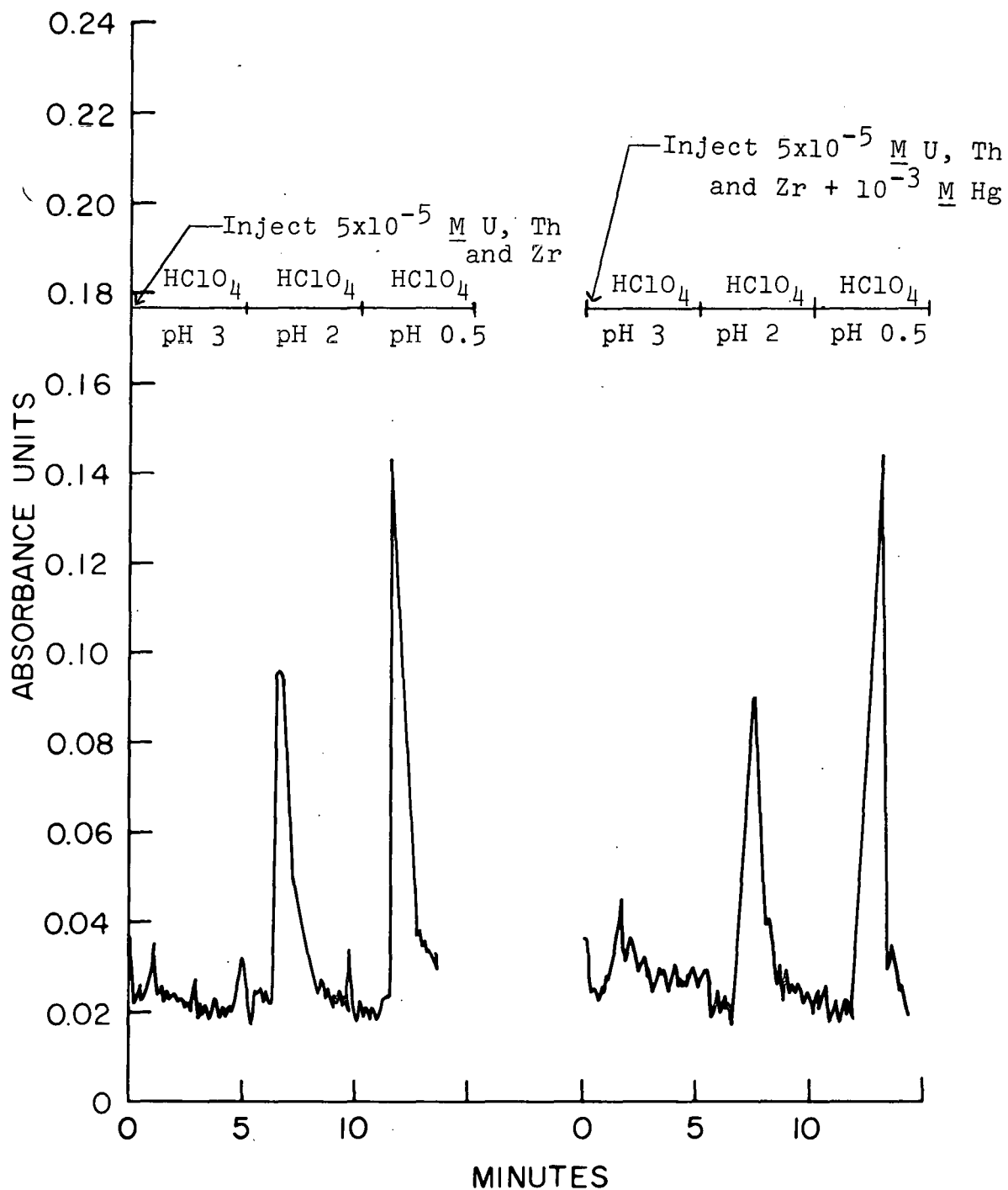

Figure 11. Determination of uranium and thorium in the presence of mercury

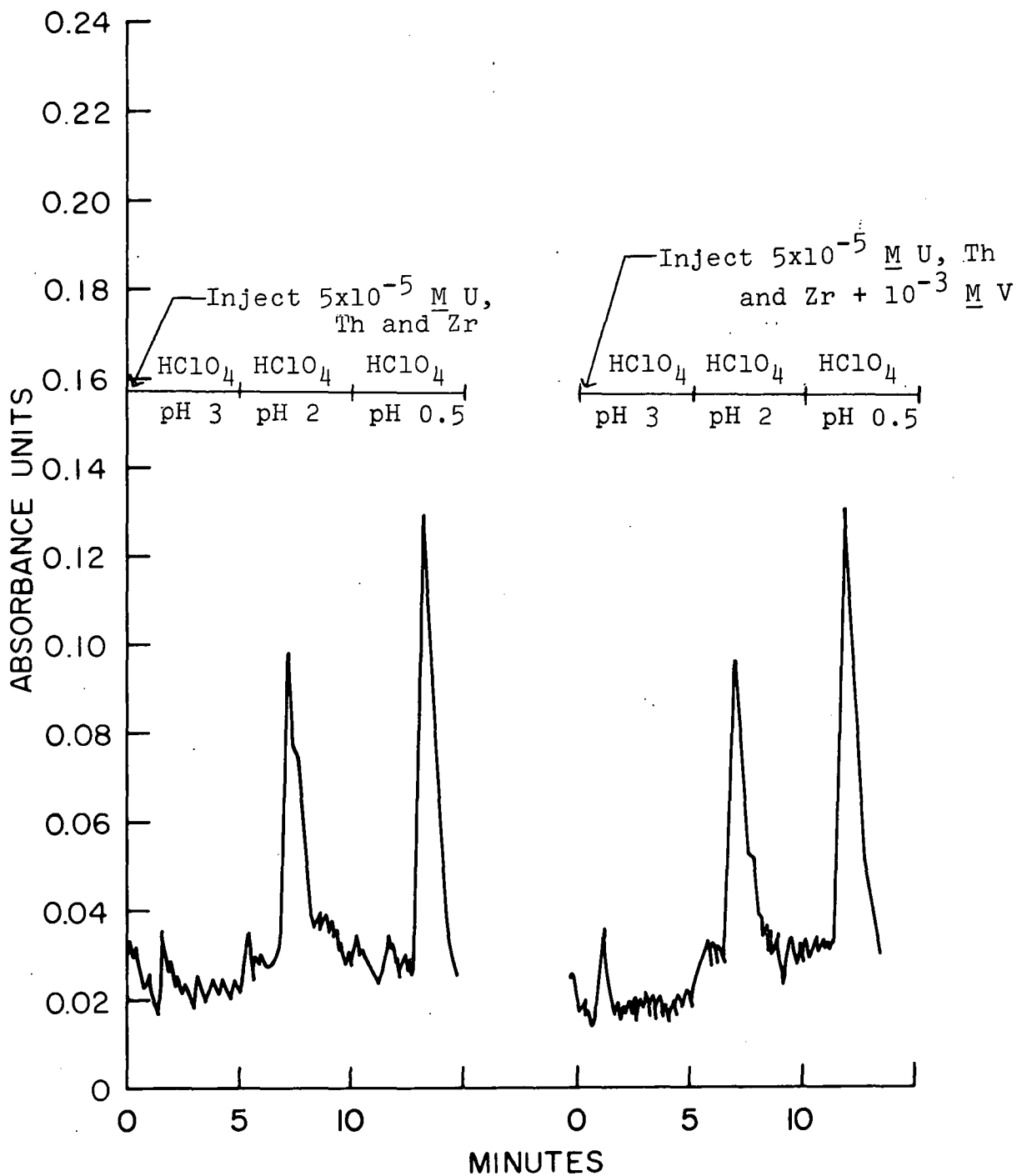

Figure 12. Determination of uranium and thorium in the presence of vanadium

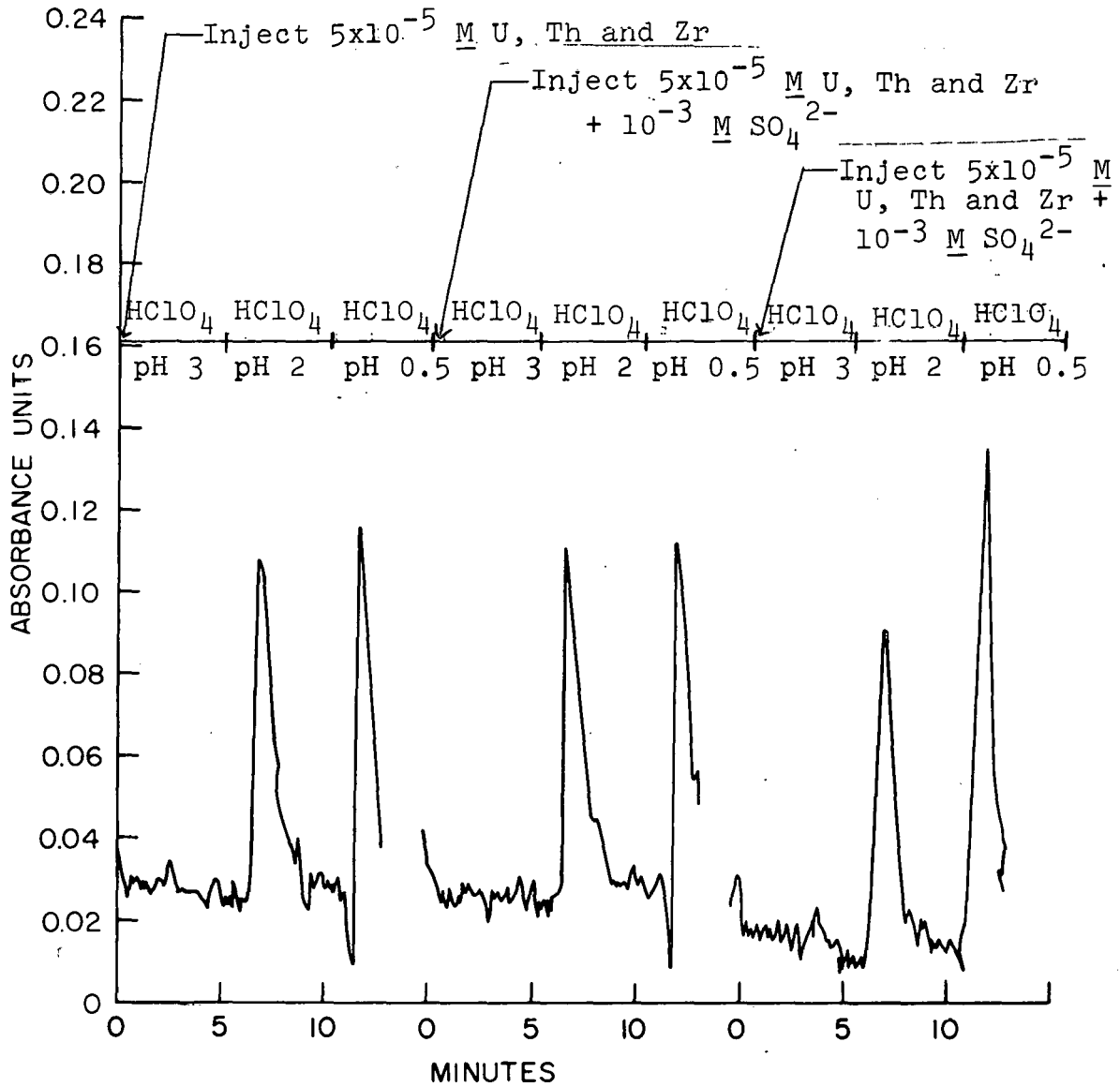

Figure 13. Determination of uranium and thorium in the presence of chloride and in the presence of sulfate

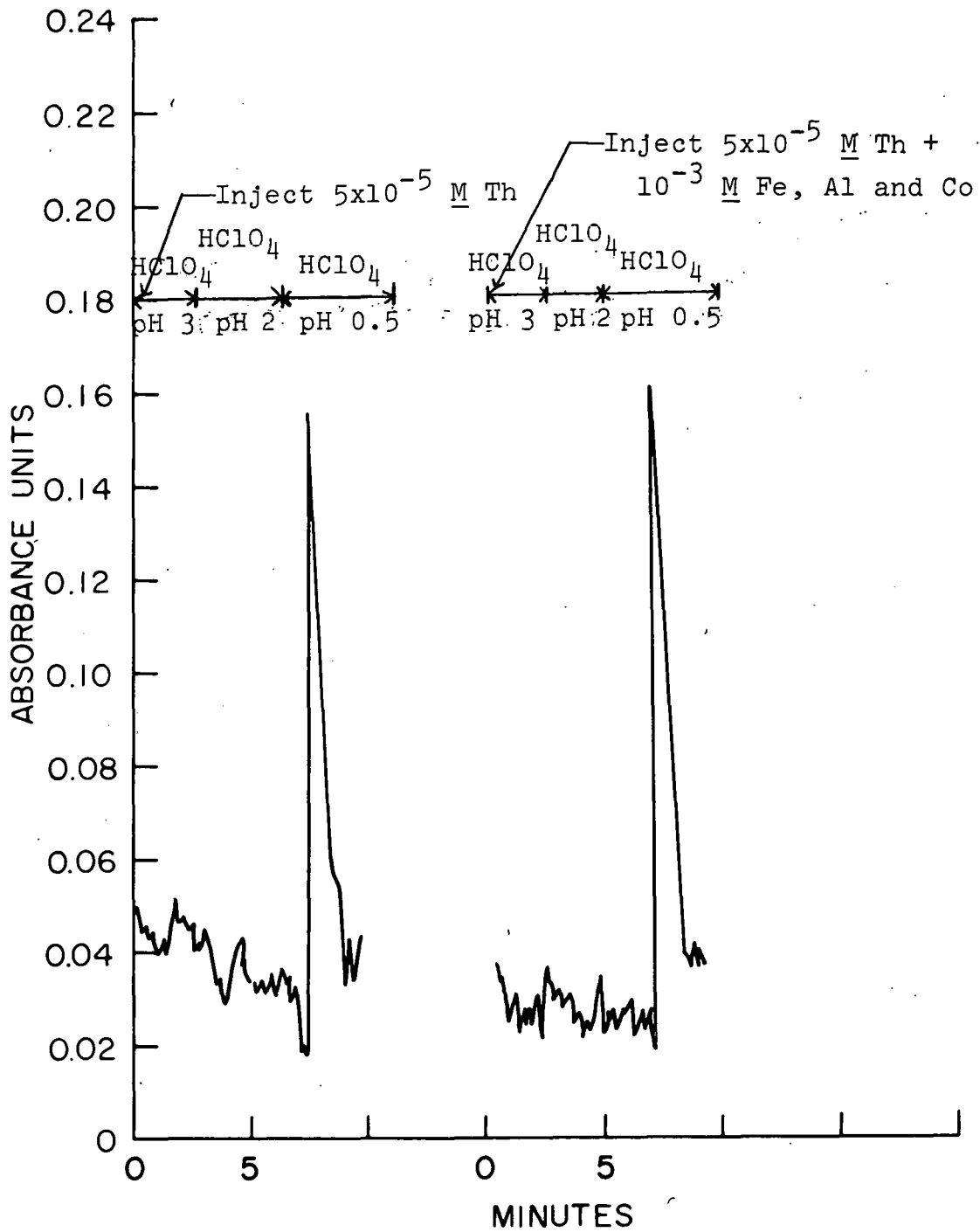

Figure 14. Determination of thorium in the presence of aluminum, iron and cobalt

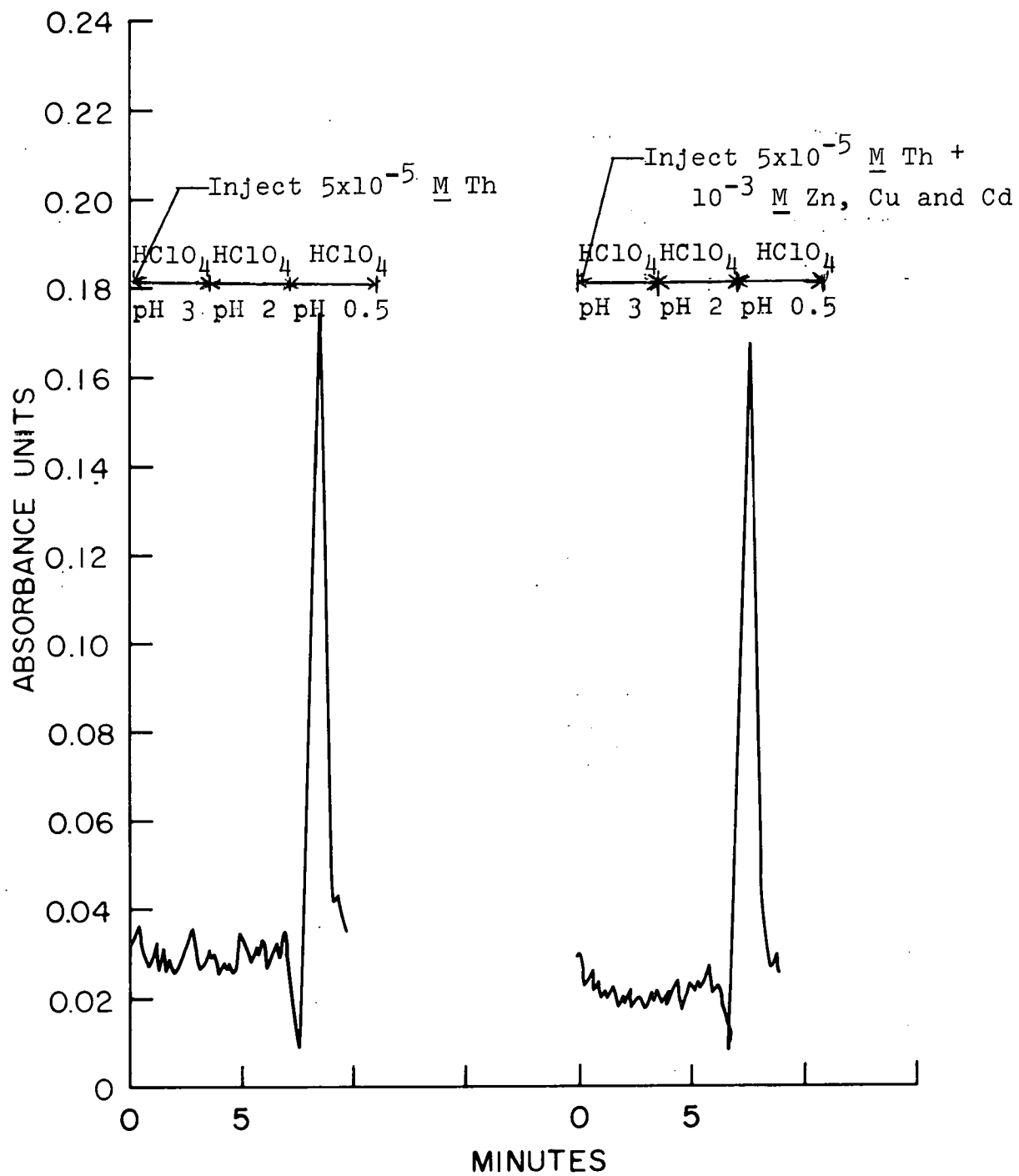

Figure 15. Determination of thorium in the presence of zinc, copper and cadmium

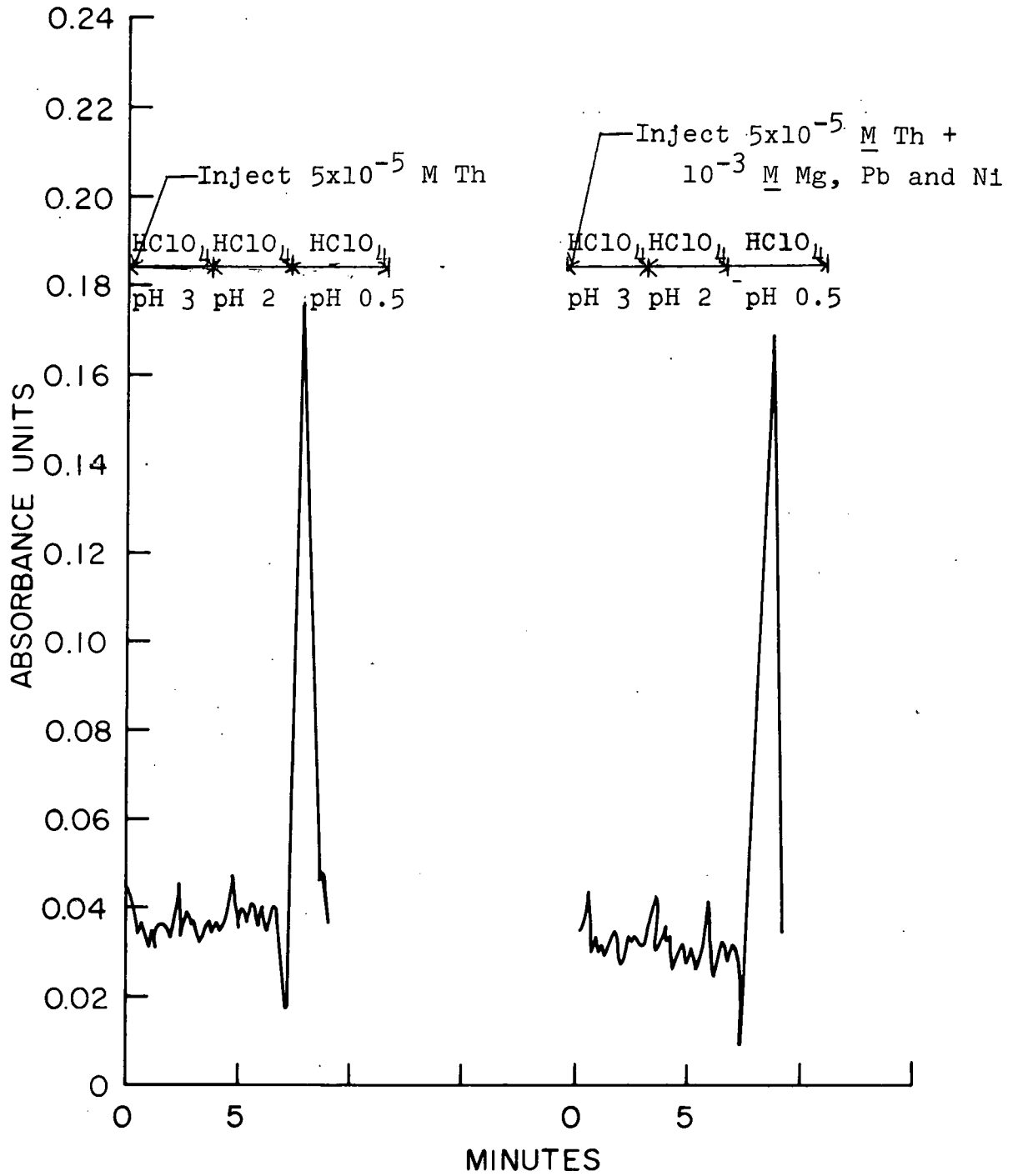

Table 16. Determination of thorium in the presence of magnesium, lead and nickel

absorbance of the metal-Arsenazo complex used to detect uranium and thorium. Phosphate does not effect uranium recovery but inhibits completely the recovery of thorium. Sulfate also interferes with the determination of thorium.

F. Analysis of Ore Samples

Low grade ores were analyzed for uranium and thorium to see if the resin had a practical use for the determination of trace amounts of the metals in real samples. About 10 mg of monazite sand was digested to dryness in a solution containing 10 ml of concentrated sulfuric acid and 10 ml of concentrated nitric acid and then dissolved in 100 ml of distilled water. Carnotite and uraninite were digested as recommended by Hildebrand et al. (81). Carnotite samples of 0.1 g were digested in 20 ml of concentrated hydrochloric acid and then digested to dryness in a solution of 15 ml of concentrated hydrochloric acid and 15 ml of concentrated nitric acid. The residue was then dissolved in 100 ml of distilled water. Uraninite samples of 0.1 g were digested in a solution containing 15 ml each of concentrated sulfuric and nitric acids and also diluted to 100 ml. The samples were analyzed in the same way as all previous samples. The results are shown in Table 6.

The results of the monazite sand analysis are what would be expected from the results of the interference studies. Monazite sand contains large quantities of rare earth

Table 6. Analysis of low grade uranium and thorium ores

Sample	Species Determined	% Found	% Previously Found
Monazite Sand	U_3O_8 and ThO_2	could not be determined quantitatively	---
Uraninite (International Atomic Energy Survey Reference Sample #S4)	U_3O_8	0.371 ± 0.053	0.375
Carnotite (USERDA Reference Materials Section, New Brunswick, NJ, Carnotite Sample #4)	U_3O_8	0.19 ± 0.02	0.18

elements which interfere with the determination of both uranium and thorium. The ore also contains a large amount of phosphate which totally inhibits the determination of thorium. However, the method is satisfactory for the determination of uranium in low grade ores such as uranite and carnotite. These ores contain large amounts of silica and other metals such as iron and vanadium which do not interfere with the determination of uranium.

G. Concentration of Gold

Work in our laboratory has shown that resins with functional groups containing atoms with free electrons have an affinity for gold and other noble metals. A problem with most of these resins is that the functional group is oxidized by the noble metal ion and is of little use after one sorption and desorption of the ion. The amide molecule is not easily oxidized, and does contain free electrons on the oxygen and nitrogen atoms. For this reason the affinity of the amide resin for the noble metals and silver was studied.

Solutions containing 10^{-3} M rhodium(III), platinum(II), silver(I), palladium(II) and gold(III) were injected into eluent streams of 1 M and 4 M hydrochloric acid. The chloride complexes of the eluted ions were monitored at 225 nm (74). Under both conditions the gold and palladium were retained while the others were eluted.

Attempts were made to separate gold and palladium on a gravity column but the ions were held so strongly that the idea of separating them was put aside. Both ions could be eluted very slowly with saturated thiourea in 0.1 M hydrochloric acid, and both could be eluted rapidly with 0.1 M sodium cyanide, but no compromise in these concentrations could be made so that the two could be separated.

Because the resin was so selective for these ions at low pH values and because it retained them so strongly, it was decided to try to use the resin for the concentration of trace amounts of gold from deionized water and sea water.

The concentration of gold from deionized water was performed by pumping 2 ℓ of deionized water containing 1 ppm of gold(III) through a 6 mm x 6 cm column of the amide resin. The gold was eluted from the resin with 50 ml of 0.1 M sodium cyanide, and the gold in the eluent determined by Walt Sutherland on the Plasma Emission Spectrophotometer at the Ames Laboratory.

The concentration of gold from sea water was performed by pumping 2 ℓ of sea water through the same column at 5 ml/min. Then, 100 ml of 0.1 M hydrochloric acid was pumped through the resin to remove any other cations that may have been sorbed, and then 100 ml of deionized water was pumped through the column to remove any acid in the resin.

The gold was then eluted with 50 ml of 0.1 M sodium cyanide, and the eluent analyzed for gold by plasma emission. This sample served as a blank. The same procedure was then performed with 2 l of sea water which was spiked with 1 ppm of gold(III) and allowed to equilibrate for 24 hours. The results of these studies are shown in Table 7.

Table 7. Recovery of gold from dilute solution

Sample	mg Au ³⁺ Taken	mg Au ³⁺ Found	% Recovery
Spiked deionized water	1.97	1.97	100
Sea water	0.00	faint trace	---
Spiked sea water	1.97	1.89	96

The problems with many resins that are selective for gold are that they are oxidized by the gold when it is sorbed and/or they must be decomposed to remove the gold once it has been sorbed. Also, most of these resins retain all of the noble metals along with the gold. When the amide resin was left in contact with gold(III) solutions for a long period of time, the yellow-gold band on the resin began to turn black. This may indicate that the gold is being reduced.

However, the black band is readily eluted from the resin with sodium cyanide, and there is no apparent change in appearance or any difference in the utility of the amide resin after many sorptions and elutions of the gold. Therefore, it would appear that this resin has an advantage over other gold selective resins in that it can be used over and over and it has greater selectivity.

H. Capacity Studies

The maximum capacities of the resin for uranium(VI), thorium(IV) and gold(III) were determined to help determine the mechanism of the complex formation between the resin and the three metal ions. The capacities of the resin for uranium were determined by both batch and column extraction techniques. Thorium capacities were determined by column extraction and gold capacities by batch extraction.

The batch extractions of uranium were performed by adding 5 ml of 1.02×10^{-2} M uranyl nitrate to 25 ml of solvent and equilibrating with 0.5 g of resin for 24 hours. The uranium remaining in solution after the extraction was determined spectrophotometrically with Arsenazo I (78).

The column extraction of uranium(VI) and thorium(IV) were performed by passing standard solutions of the ions through columns containing 0.5 g of resin until saturation of the resin was reached. The excess metal was removed

from the column by washing with petroleum ether. The metal ions were then eluted from the resin with 0.1 M perchloric acid. The uranium was analyzed with Arsenazo I. Thorium was analyzed by an EDTA titration using Xylenol Orange indicator (82).

Gold capacities were determined by equilibrating 10 ml of 0.1 M gold(III) with 30 ml of varying concentrations of hydrochloric acid and 0.5 g of resin for 24 hours. The resin was filtered from the solution, and an aliquot of the solution was diluted to 50 ml with 10^{-3} M thiourea in 10^{-3} M hydrochloric acid. The absorbance of the thiourea complex was measured at 260 nm. The uranium and thorium capacities are shown in Table 8. The gold capacities are shown in Table 9.

Table 8. Capacity of amide resin for uranium and thorium

Metal Ion	Type of Capacity	pH	Capacity (meq/g)
UO_2^{2+}	Batch	3	0.0295
UO_2^{2+}	Batch	4	0.0247
UO_2^{2+}	Column	3	0.0780
UO_2^{2+}	Column	4	0.0463
Th^{4+}	Column	2	0.0472
Th^{4+}	Column	3	0.0429

Table 9. Capacity of amide resin for gold

HCl concentration	Au capacity (mmoles/gram)
0.5 <u>M</u>	1.74
1.0 <u>M</u>	1.80
2.0 <u>M</u>	1.32
4.0 <u>M</u>	1.88

The sorption of uranium is very pH-dependent. At pH values less than 3, uranium is not retained. At pH 3, the capacity of the resin for uranium is maximum. The capacity of the resin decreased in going from pH 3 to pH 4. The sorption of thorium is not as pH-dependent, but there is a slight decrease in capacity in going from pH 2 to pH 3, and at pH 1.5 thorium is not retained.

The capacity of the resin for uranium and thorium is very low compared to the number of amide functional groups on the resin. It is likely that the only time complexes are formed between the resin and the metal ions is when the functional groups are so arranged that more than one amide group can coordinate to a metal ion. The highly cross-linked XAD-4 matrix would make the probability of such an arrangement small and may explain the low capacity of the resin for uranium and thorium.

The hydrochloric acid concentration had little effect on the capacity of the resin for gold(III). The capacity of the resin for gold indicates the formation of 1:1 amide-gold complexes. It is likely that the AuCl_4^- complex is coordinating to either the oxygen or nitrogen atom of the amide molecule with the loss of a chloride ion.

I. Conclusions

The amide resin was prepared with the goal of preparing a resin with a high capacity for uranium. The resin was quite selective for uranium and proved to be useful for the rapid analysis of low grade uranium ores. However, the capacity of the resin for uranium was not nearly as high as was intended. Attempts were made to prepare an amide resin with a larger capacity for uranium. Because the low capacity was believed to be caused by the inability of more than one amide group on the resin to coordinate with uranyl ions, a resin was prepared that contained amide groups on a longer, more flexible chain. This resin was prepared by aminating chlormethylated XAD-4 with triethylenetetramine and then acetylating the amine groups. However, this resin had no affinity for uranium at all.

Although the uptake of gold by the resin was not one of the original goals of the resin, it proved to be one of its most interesting and useful features. The high selectivity

and capacity of the resin for gold make it very useful for the concentration of gold from dilute solution. Also, the resin has the advantage over many other gold-selective resins of being very stable. The resin can be used many times for the sorption and desorption of gold without any apparent loss in capacity.

V. TRIETHYLENETETRAMINE RESIN FOR THE
CONCENTRATION AND SEPARATION
OF METAL IONS

A. Apparatus and Reagents

The liquid chromatograph was the same as the one used for the work with the amide resins with one modification. The detector used in this work was a Tracor 970 variable wavelength detector.

Ethylenediamine was purchased from Fisher Scientific, and triethylenetetramine, b.p. 266-267°C, n_D^{20} 1.4971, d 0.982, was purchased from Aldrich Chemical Company. Chromatographic determinations of calcium(II) and magnesium(II) were monitored with PAR.

All other apparatus and reagents used have been described in Section IV.

B. Synthesis, Characterization and
Capacity Studies

A resin containing ethylene diamine groups, and a resin containing triethylenetetramine groups were prepared. The scheme of the synthesis is as follows:

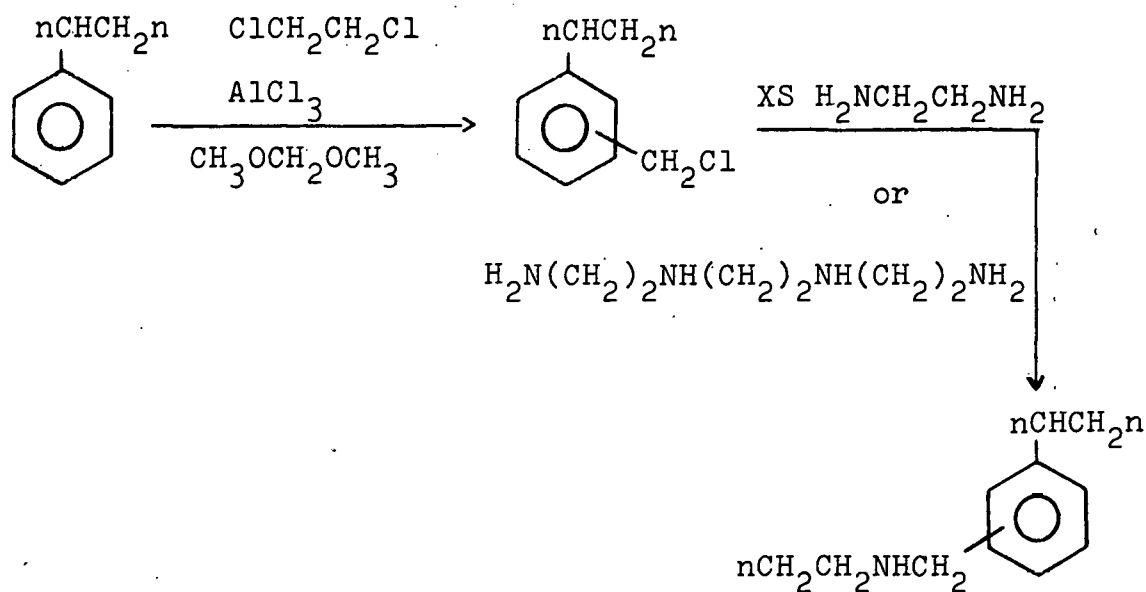

The chloromethylation procedure was a modification of that of the Permutit Co. Ltd. (83). To 5 g of dry 80-100 mesh XAD-4 was added 50 ml of ethylene chloride. The resin was allowed to swell for 2 hours. To 7 g of anhydrous aluminum chloride was added 100 ml of ethylene chloride and this mixture was placed in an ice bath. Then, 5 ml of methylal was added to the aluminum chloride mixture. The resin slurry was then added to this mixture and allowed to stand overnight. The resin was then washed with 0.1 M hydrochloric acid, water, and methanol. The chloromethylated resin was air dried and aminated by refluxing with a large excess of the appropriate amine for 4 hours. The resins were then washed with water, 0.1 M hydrochloric acid and methanol.

The chlorine content of the chloromethylated resin was determined by the method of Cheng (84) and found to contain 1.3 mmoles of chlorine per gram of resin. The nitrogen content of the resins was determined by the Dumas method.

The capacities of the amine resins for copper(II) were determined by a column extraction technique. Approximately 0.2 g of resin was added to a small gravity column. The resin was washed with 0.1 M hydrochloric acid, water and the appropriate buffer. To the column was then added 5 ml of 0.1 M copper(II) in the appropriate buffer. The resin was then washed with the buffer, and the amount of copper remaining in the eluent determined by an EDTA titration with NAS indicator (82).

To determine the hydrogen capacity of the amine resins, 0.5 g of the resin was allowed to stand in 30 ml of 0.1 M sodium hydroxide for 8 hours. The resin was then washed with water until neutral and then allowed to stand in 30 ml of 0.1 M hydrochloric acid for 8 hours. The excess acid was then filtered from the resin and titrated with sodium hydroxide.

Infrared spectra of the amine resins were inconclusive because the N-H stretching vibrations were covered by bands from water entrapped in the resin. Table 10 summarizes the characterization of the amine resins.

Table 10. Characterization of amine resins.

Resin	Nitrogen ^a content	H ⁺ capacity	Cu ²⁺ Capacity				
			pH 3 HCl	pH 5 acetate	pH 6 acetate	pH 7 acetate	pH 8 acetate
Ethylenediamine	2.71	1.09	0.00	0.453	0.608	0.548	0.502
Triethylenetetramine	3.50	1.79	0.171	0.456	0.559	0.512	0.536

^aAll values in mmoles of element/g of resin.

From the chlorine content of the resin one would predict that if all of the chloromethyl groups on the resin reacted with the amines, the ethylenediamine resin would have a nitrogen content of 2.6 mmole/g and the triethylenetetramine resin would have a nitrogen content of 5.2 mmole/g. The data in Table 10 indicate that there is one ethylenediamine group on the resin for every chloromethyl group that was on the chloromethylated resin. However, the nitrogen analysis of the triethylenetetramine resin indicates that the reaction of the chlorine on the chloromethylated resin with the amine was not in a 1:1 ratio in all cases. This was probably due to cross-linking of the polyamine between two chloromethyl groups on the resin.

The hydrogen ion capacities of the resin indicate that only half of the amine nitrogens are basic enough to be titratable in aqueous solution. The sorption of copper by the diamine resin is much more pH dependent than the sorption of copper by the tetramine resin. This indicates that the copper complexes of the tetramine resin are more stable than those of the diamine resin, as would be expected from data on the amine monomers. The maximum copper capabilities of the two resins indicate that the amine/copper ratios for sorbed copper are approximately 4:1 for the diamine and 8:1 for the tetramine. This may indicate that chelates of the following type are being formed:

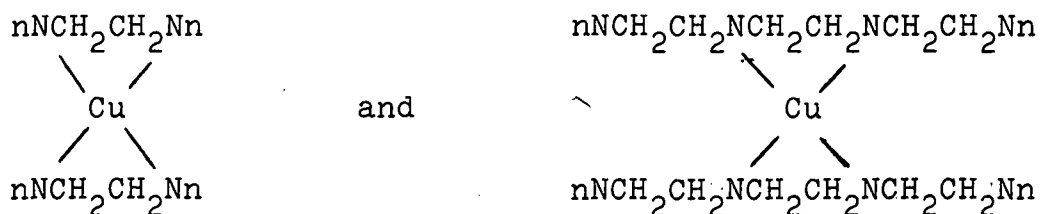

C. Separation Schemes

The stability constants of monomer ligand-metal complexes and similar resin ligand-metal complexes are often of the same order of magnitude. Therefore, it seemed feasible to separate copper from other transition metals with these resins. Data on the stability constants for the monomeric amines with various transition metals indicate that the order of stability of the metal amine complexes for both amines is copper(II) > nickel(II) > zinc(II) > cobalt(II) > cadmium(II) (85,86). The differences in K_1 for the copper and nickel amine complexes are three orders of magnitude for ethylenediamine and six orders of magnitude for triethylenetetramine. These data indicate that it should be possible to separate copper from the other metal ions with both resins. However, good separations were possible only with the tetramine resin.

The retention of copper(II), nickel(II), cobalt(II), cadmium(II), zinc(II), iron(II) and aluminum(II) from several different eluents were studied for the two resins. None of the ions were retained by the diamine resin from pH 3 hydrochloric acid solutions. Copper was retained from pH 4 acetate buffer, but severe tailing of other ions made

separations impractical. Changing the salt concentrations of eluents with pH values between 3 and 4 failed to produce good separations, so work was concentrated on the tetramine resin.

The tetramine resin showed much greater selectivity for copper. With pH 3 hydrochloric acid as the eluent, copper was only partially retained while the other ions were completely eluted. However, with the addition of 0.02 M sodium chloride to the pH 3 acid the copper was completely retained and the other ions were still rapidly eluted. The addition of salt was probably necessary for the neutralization of the copper-amine complex. It was also found that copper(II), cobalt(II), nickel(II), cadmium(II) and zinc(II) were retained from pH 5.5 acetate buffer while calcium(II) and magnesium(II) were eluted at these conditions. Once the ions were sorbed by the resin, they could all be rapidly eluted with 1 M mineral acids. It was also noted that the addition of sulfate, nitrate or perchlorate salts to the pH 3 hydrochloric acid rather than the addition of sodium chloride made no difference in the retention of copper by the resin.

Earlier work with amine resins (8,12,13) indicated that they also have a strong affinity for silver(I) and mercury(II). Therefore, experiments were performed to examine the affinity of the tetramine resin for silver(I) and mercury(II), and also for lead(II), uranium(VI) and

dysprosium(III). The affinity of the resin for calcium(II) and magnesium(II) at pH 8 was also examined. Table 11 summarizes the results of these experiments.

Because the resin had such a high affinity for silver, a separation of silver and copper was performed by injecting a solution of the two into an eluent stream of pH 2 perchloric acid. At this pH silver is retained and copper passes through the column. The silver was then eluted with 1 M perchloric acid. The chromatogram is shown in Figure 17. These data also indicate that the tetramine resin has a strong affinity for mercury(II) at low pH values. This should make it possible to separate mercury(II) from all of the ions studied.

D. Interference Studies

Tables 12 and 13 summarize the effects of foreign ions on the determination of copper(II). Table 14 summarizes the effect of 100-fold excesses of calcium(II) and magnesium(II) on the determination of copper(II), cobalt(II), nickel(II), cadmium(II) and zinc(II). Figures 18 through 29 are chromatograms of several of these studies. In all cases the eluent and dye flow rates were each 1 ml/min and a 50 μ l sample loop was used.

All of the determinations were within the limits of experimental error except for the determinations of copper in the presence of 100-fold excesses of iron, cadmium and

Table 11. Affinity of tetraamine resin for several cations

Eluent	Ag ¹⁺	Ca ²⁺	Pb ²⁺	Mg ²⁺	Hg ²⁺	Dy ³⁺	UO ₂ ²⁺
10 ⁻³ <u>M</u> HNO ₃	---	---	E ^a	---	R ^b	---	---
10 ⁻² <u>M</u> HNO ₃	---	---	E	---	R	---	---
10 ⁻¹ <u>M</u> HNO ₃	---	---	---	---	R	---	---
pH 3 HCl 0.02 <u>M</u> NaCl	---	---	E	---	R	---	E
1 <u>M</u> HCl	---	---	E	---	E	---	---
1 <u>M</u> HClO ₄	E	---	---	---	---	---	---
10 ⁻¹ <u>M</u> HClO ₄	E	---	---	---	---	---	---
10 ⁻² <u>M</u> HClO ₄	R	---	---	---	---	---	---
10 ⁻³ <u>M</u> HClO ₄	R	---	---	---	---	E	---
pH 5.5 acetate buffer	---	---	---	---	---	E	R
pH 8 acetate buffer	---	E	---	E	---	---	---

^aE = eluted.

^bR = retained.

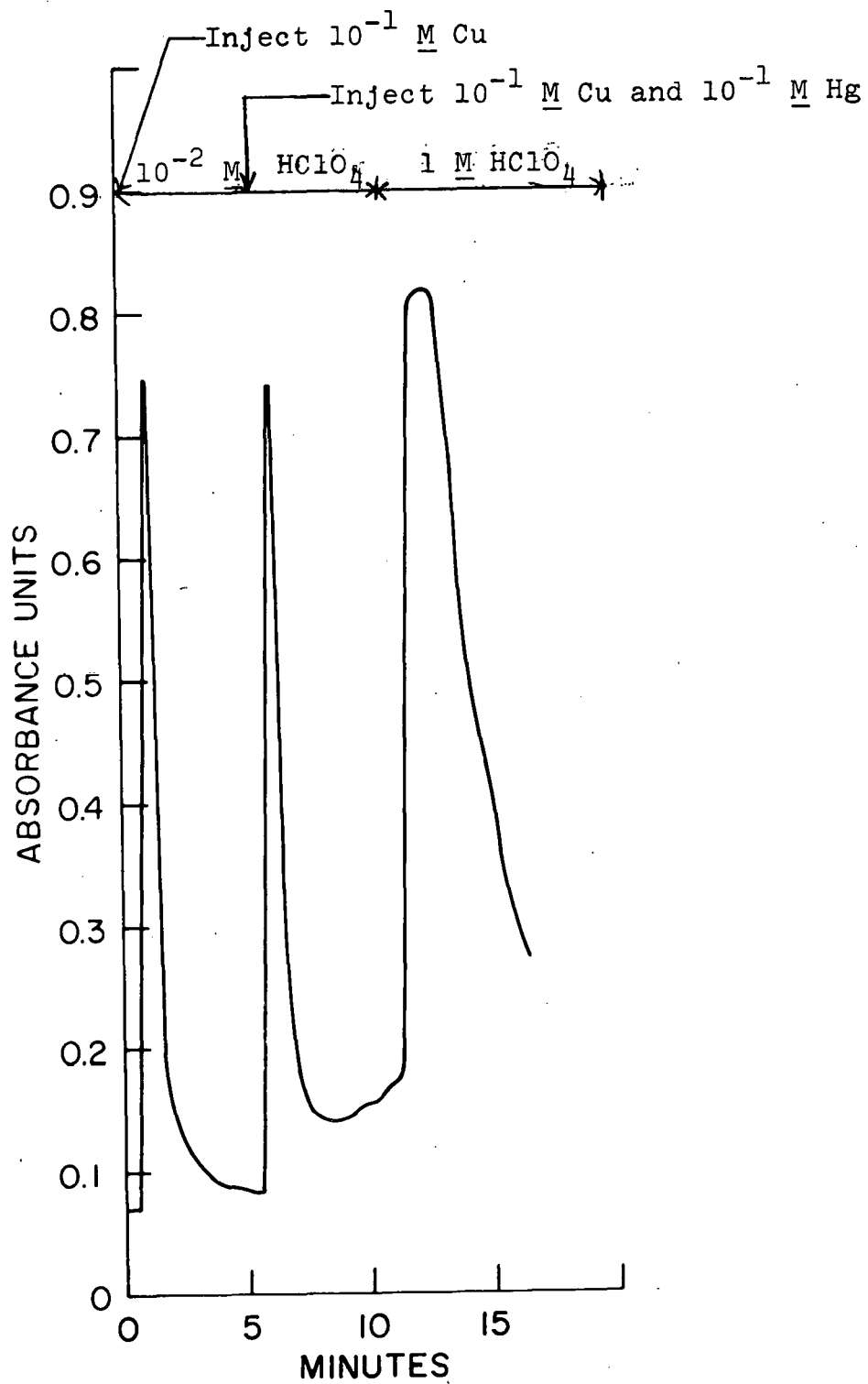

Figure 17. Separation of copper and silver

Table 12. Determination of copper in the presence of 100-fold excesses of foreign ions

Interfering Ion	mg Cu taken column 1 ^a	mg Cu found column 1	% recovery	mg Cu taken column 2 ^b	mg Cu found column 2	% recovery	Average recovery
Cd ²⁺	3.18x10 ⁻⁵	2.94x10 ⁻⁵	92.5	3.18x10 ⁻⁴	3.12x10 ⁻⁴	98.2	95.3
Fe ³⁺	3.18x10 ⁻⁵	3.35x10 ⁻⁵	105.5	3.18x10 ⁻⁴	3.27x10 ⁻⁴	103.0	104.2
Ni ²⁺	3.18x10 ⁻⁵	3.18x10 ⁻⁵	100.0	3.18x10 ⁻⁴	3.22x10 ⁻⁴	101.2	100.6
Co ²⁺	3.18x10 ⁻⁵	3.10x10 ⁻⁵	97.6	3.18x10 ⁻⁴	3.10x10 ⁻⁴	97.6	97.6
Zn ²⁺	3.18x10 ⁻⁵	2.81x10 ⁻⁵	88.5	3.18x10 ⁻⁴	2.81x10 ⁻⁴	88.5	88.5
Al ³⁺	3.18x10 ⁻⁵	3.21x10 ⁻⁵	101.0	3.18x10 ⁻⁴	3.22x10 ⁻⁴	101.2	101.1

^aColumn 1: 3 mm x 15 cm.

^bColumn 2: 6 mm x 4.5 cm.

Table 13. Determination of copper in the presence of equal molar amounts of foreign ions

Interfering Ion	mg Cu taken ^a	mg Cu found	% Recovery
Zn ²⁺	3.18×10^{-3}	3.16×10^{-3}	99.5
Cd ²⁺	3.18×10^{-3}	3.21×10^{-3}	101.1
Ni ²⁺	3.18×10^{-3}	3.17×10^{-3}	99.8
Fe ³⁺	3.18×10^{-3}	3.13×10^{-3}	98.3
Co ²⁺	3.18×10^{-3}	3.28×10^{-3}	103.1
Al ³⁺	3.18×10^{-3}	3.24×10^{-3}	101.8

^aAll determinations on column 2.

Table 14. Determination of transition metals in the presence of 100-fold excesses of calcium and magnesium

Interfering Ion	mg taken column 1	mg found column 1	% recovery	mg taken column 2	mg found column 2	% recovery	Average recovery
Cu ²⁺	3.18x10 ⁻³	3.18x10 ⁻³	100.0	3.18x10 ⁻³	3.06x10 ⁻³	96.2	98.1
Co ²⁺	2.94x10 ⁻³	2.81x10 ⁻³	95.5	2.94x10 ⁻³	2.95x10 ⁻³	100.4	97.9
Ni ²⁺	2.93x10 ⁻³	2.86x10 ⁻³	97.5	2.93x10 ⁻³	2.87x10 ⁻³	98.0	97.7
Cd ²⁺	5.62x10 ⁻³	5.31x10 ⁻³	94.5	5.62x10 ⁻³	5.77x10 ⁻³	102.6	98.5
Zn ²⁺	3.27x10 ⁻³	3.12x10 ⁻³	95.5	3.27x10 ⁻³	3.27x10 ⁻³	100.0	97.7

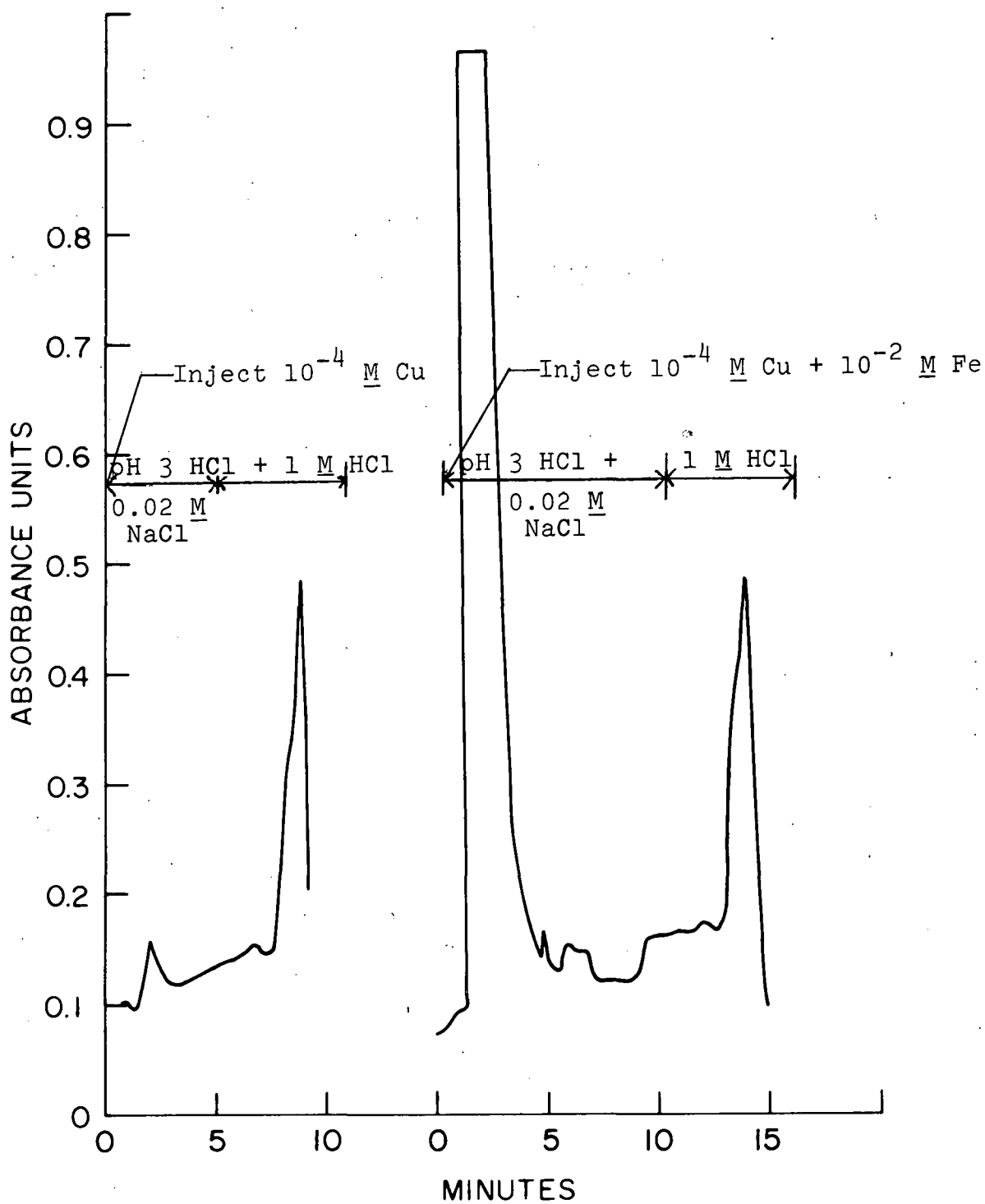

Figure 18. Determination of copper in presence of 100-fold excess of iron

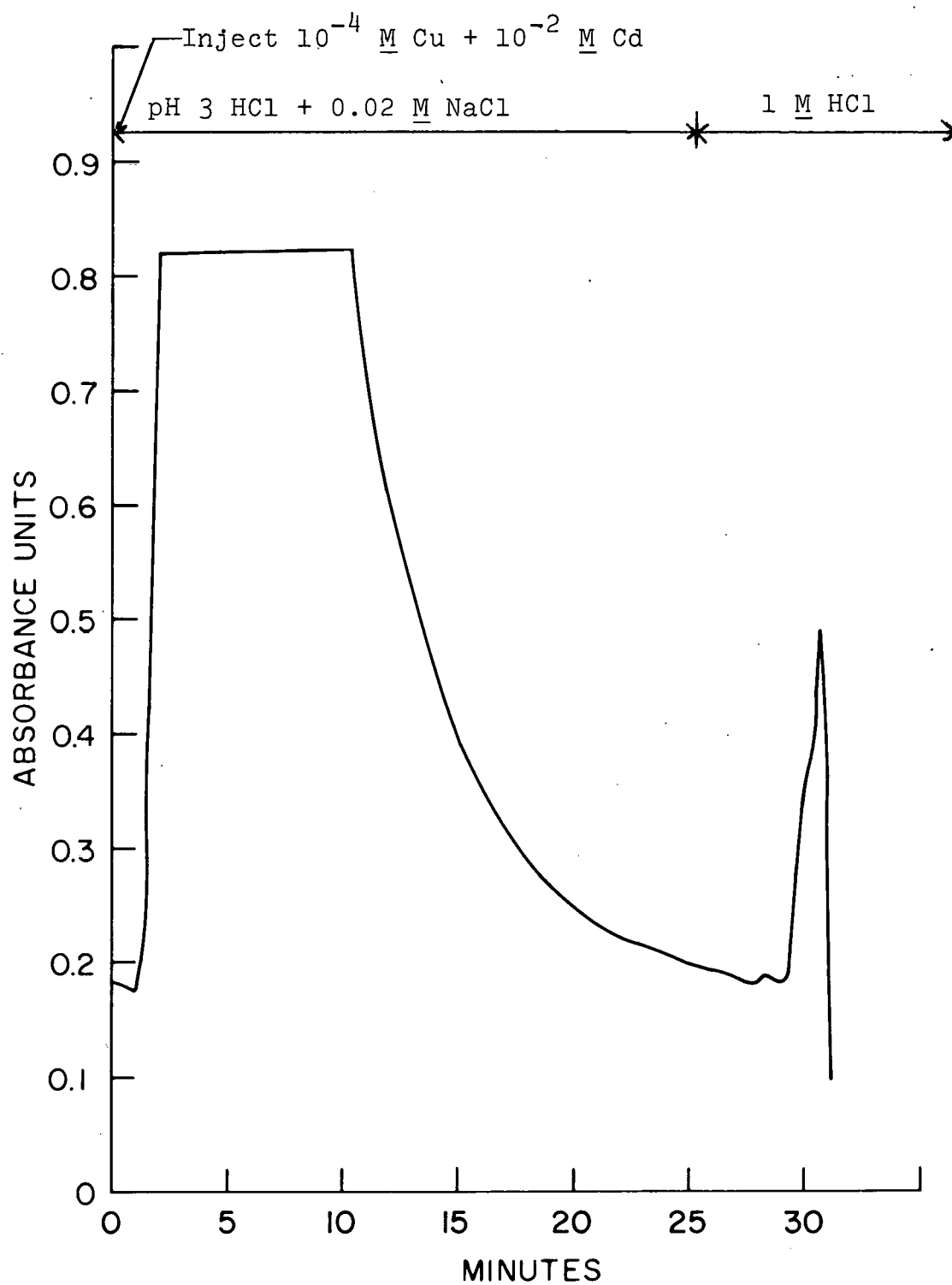

Figure 19. Separation of copper and 100-fold excess of cadmium

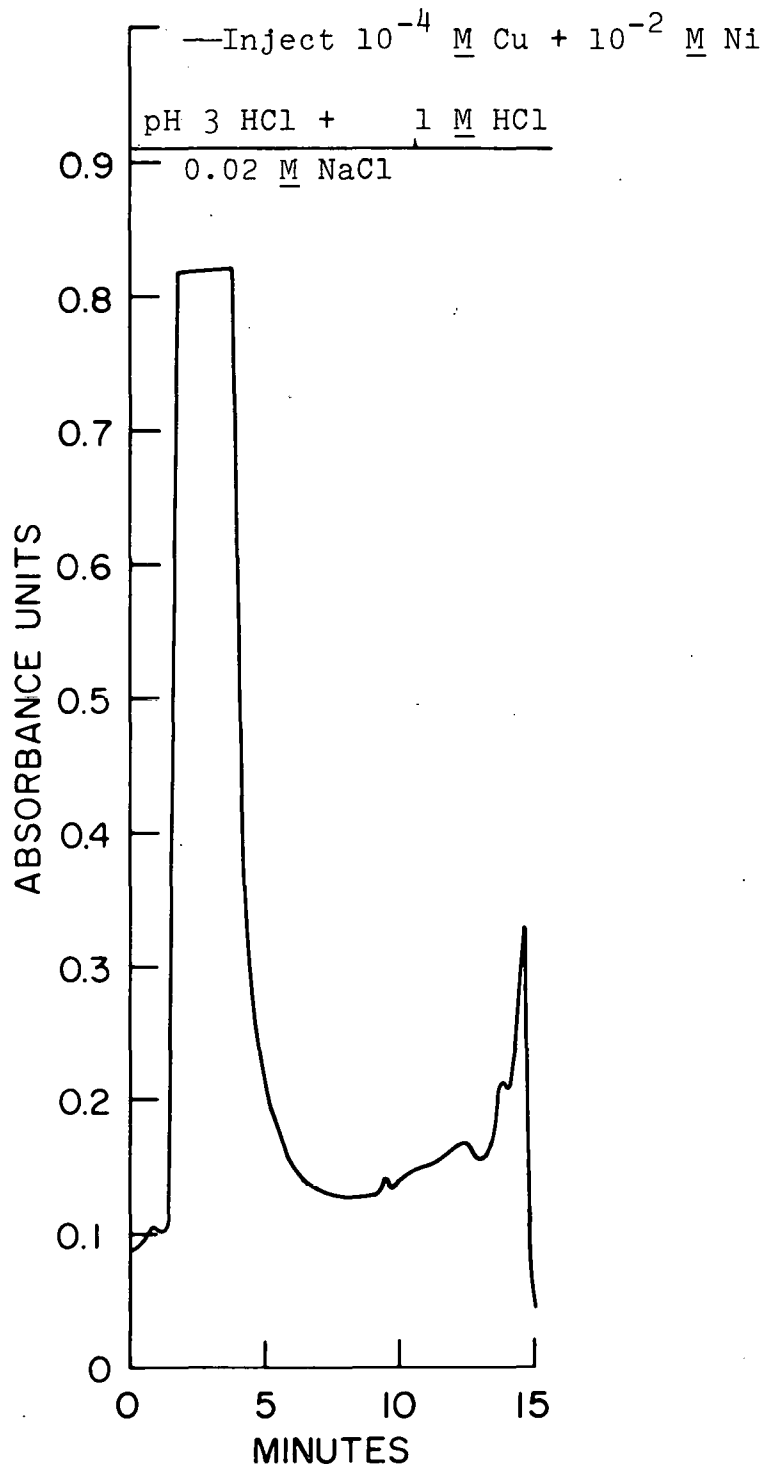

Figure 20. Separation of copper and 100-fold excess of nickel

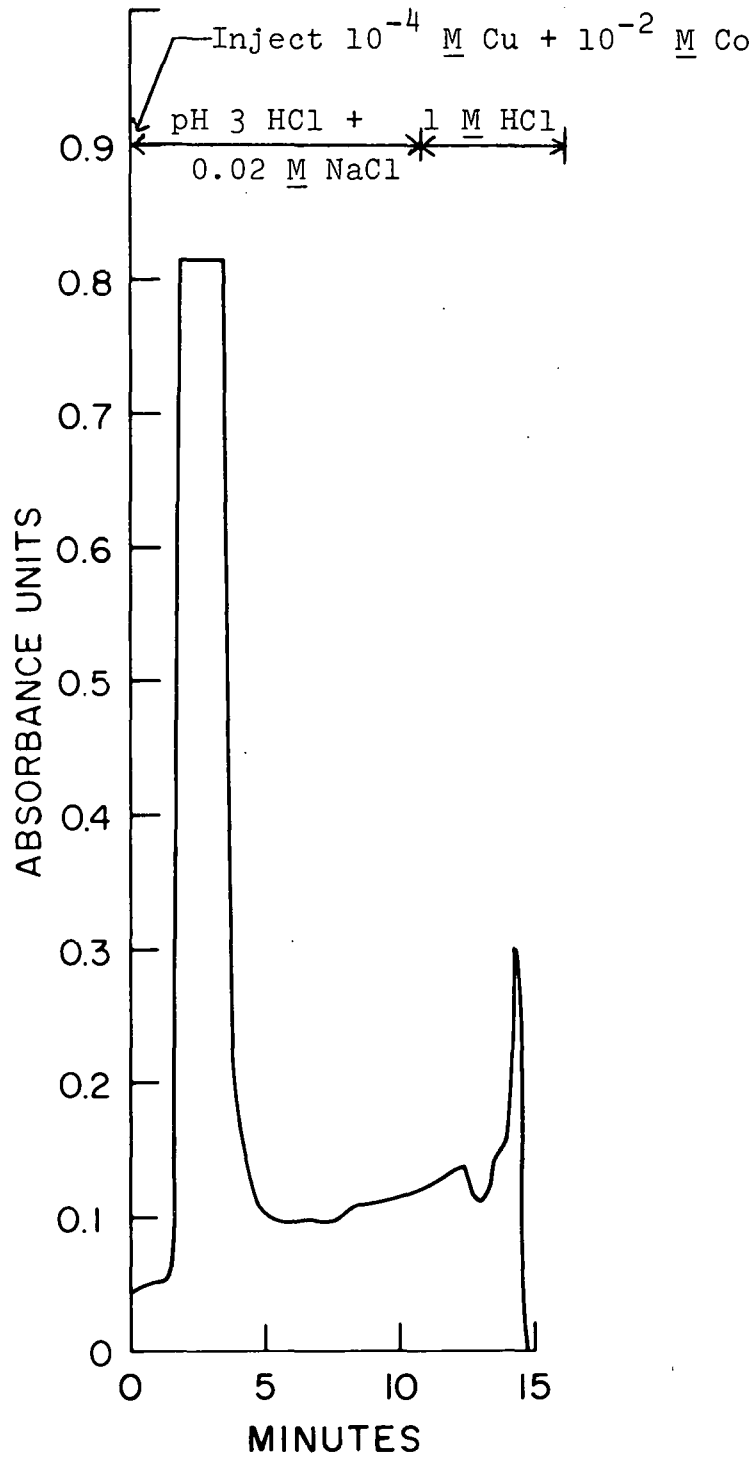

Figure 21. Separation of copper and 100-fold excess of cobalt

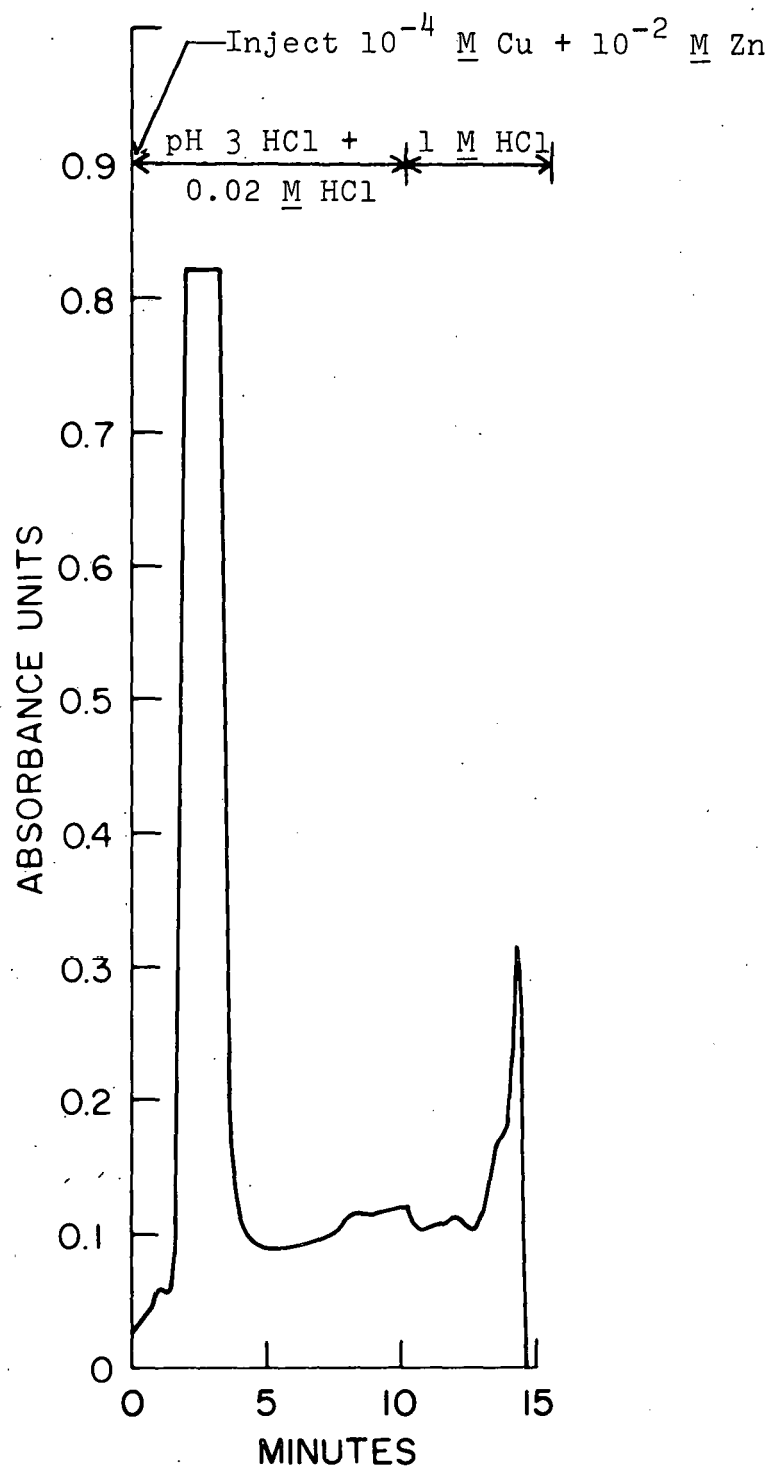

Figure 22. Separation of copper and 100-fold excess of zinc

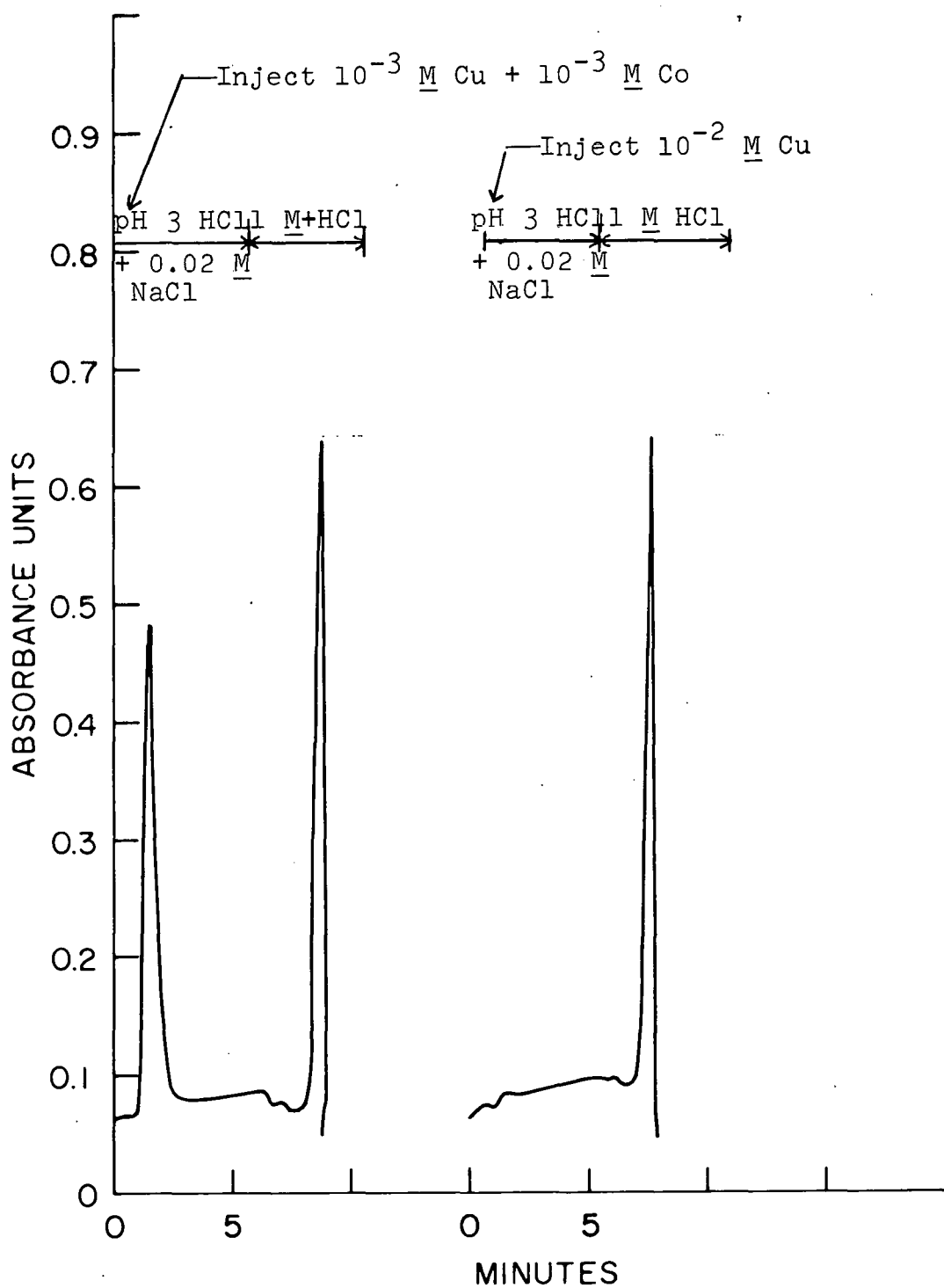

Figure 23. Determination of copper in the presence of an equal molar amount of cobalt

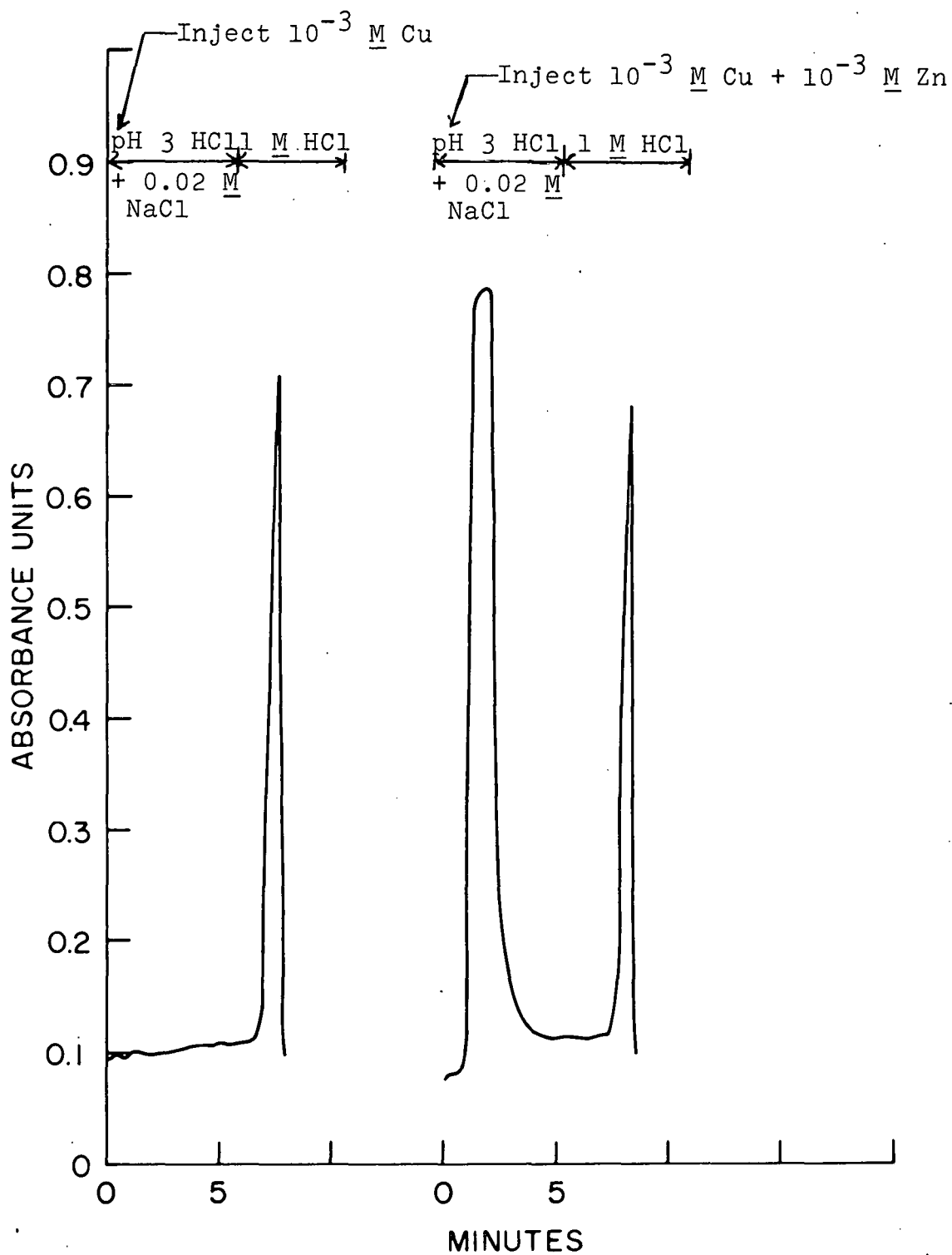

Figure 24. Determination of copper in the presence of an equal molar amount of zinc

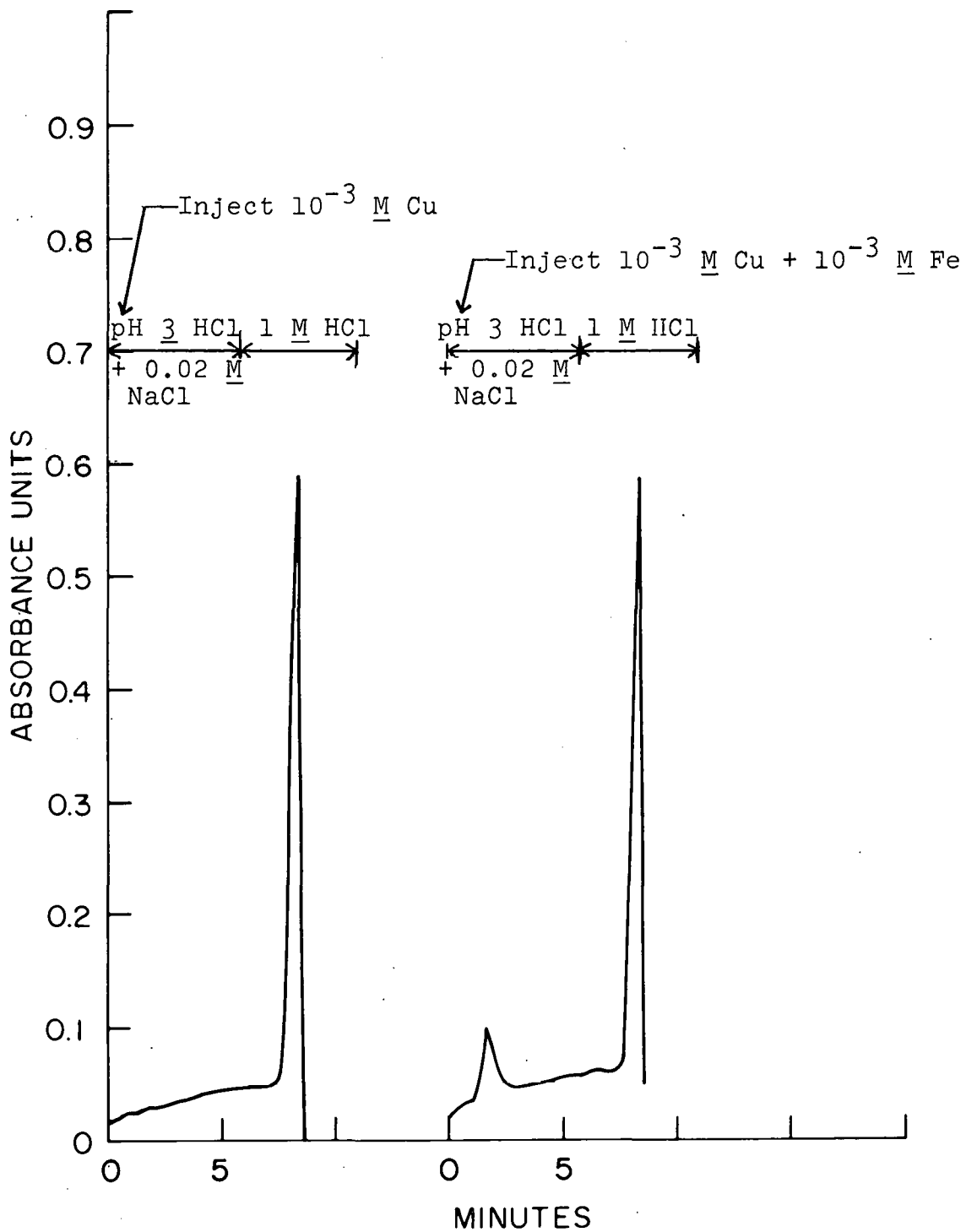

Figure 25. Determination of copper in the presence of an equal molar amount of iron

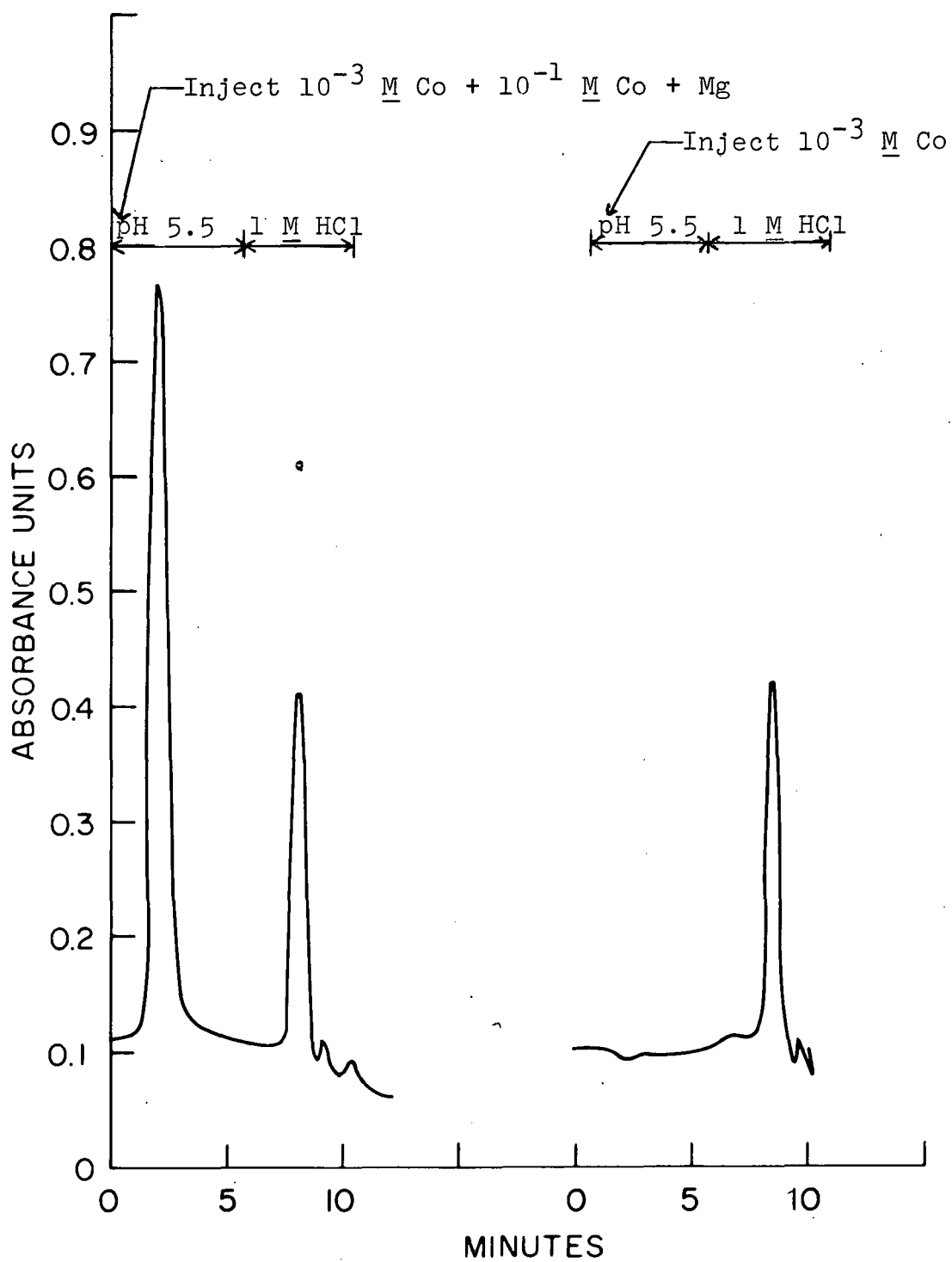

Figure 26. Determination of cobalt in the presence of 100-fold excesses of calcium and magnesium

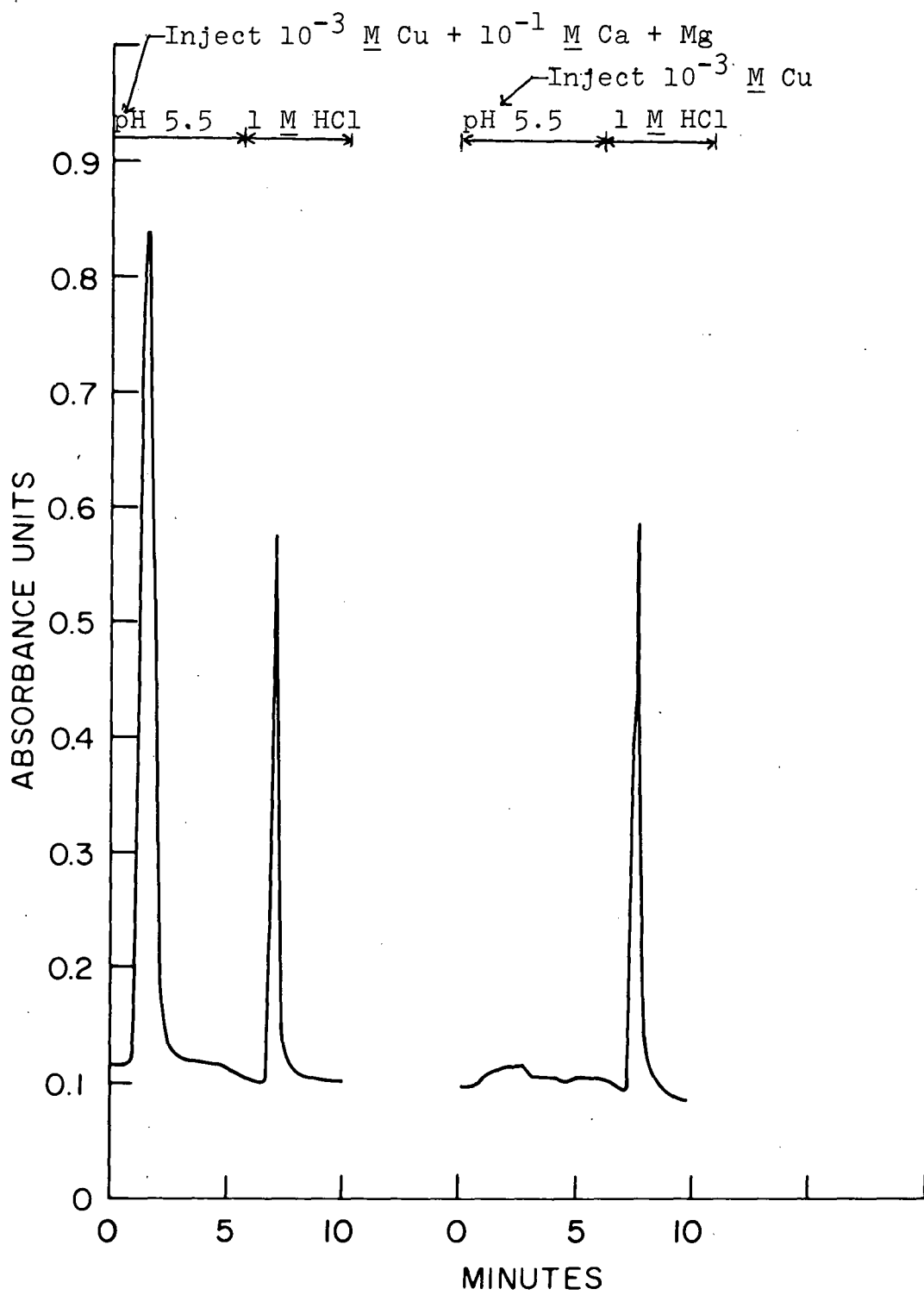

Figure 27. Determination of copper in the presence of 100-fold excesses of calcium and magnesium

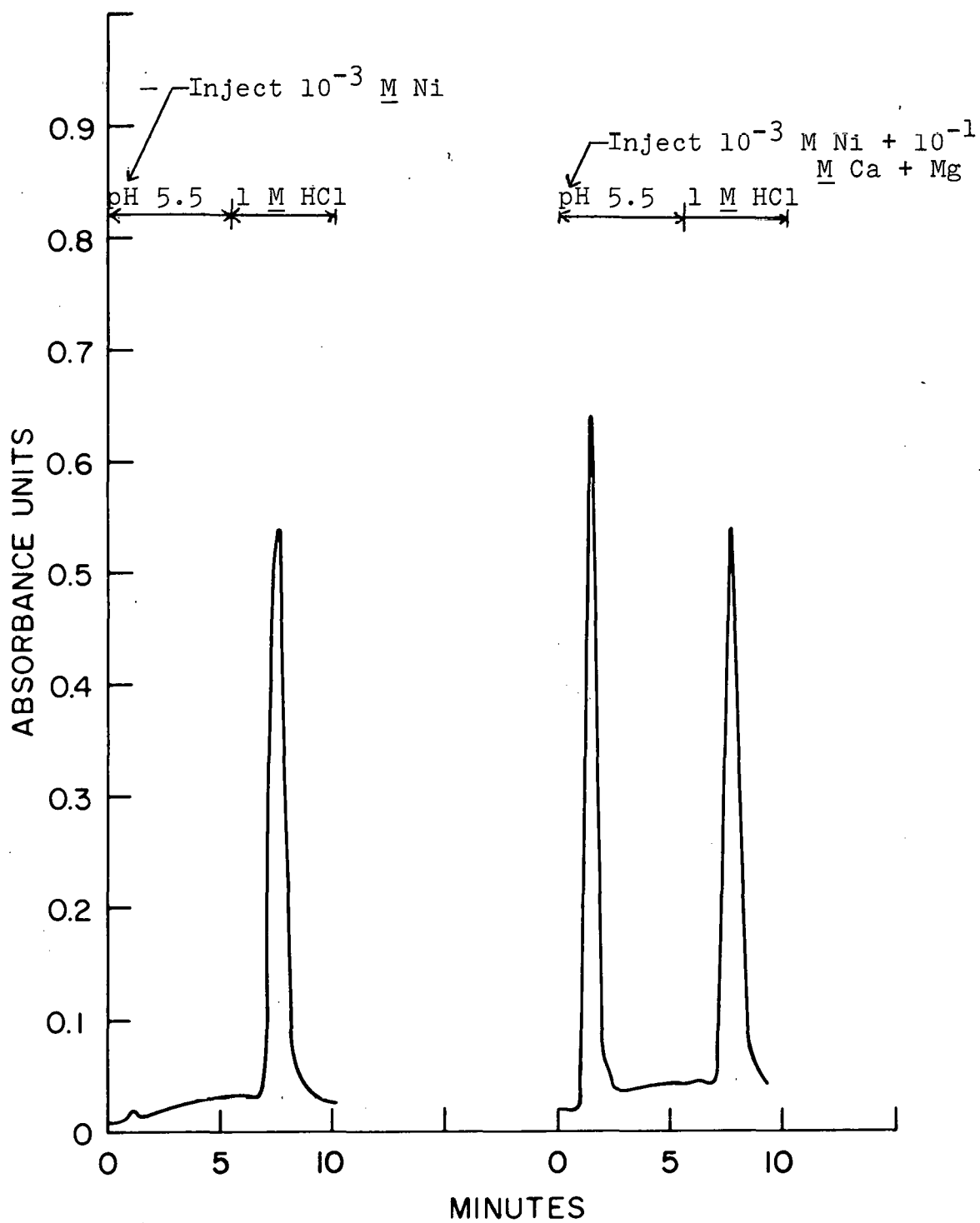

Figure 28. Determination of nickel in the presence of 100-fold excesses of calcium and magnesium

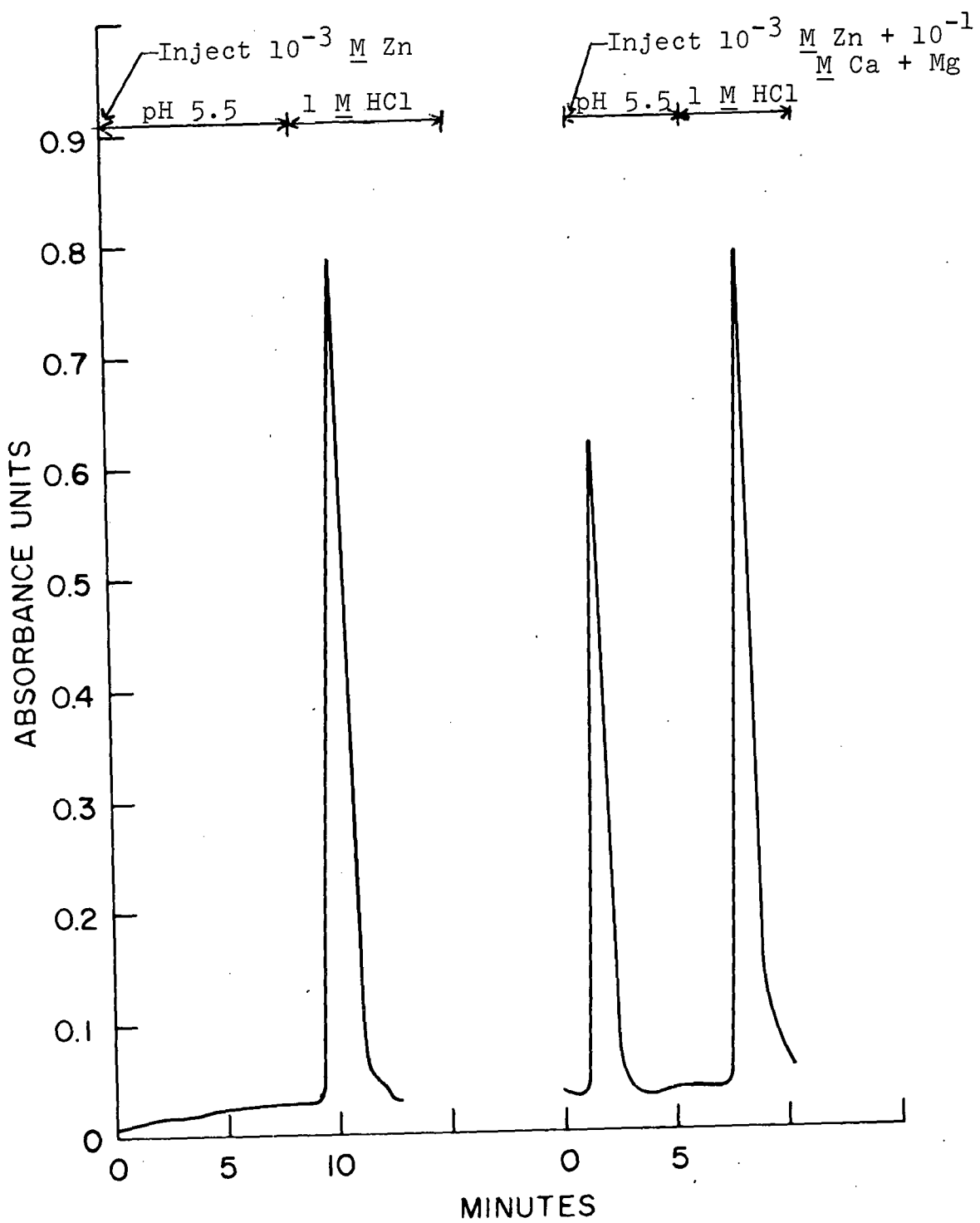

Figure 29. Determination of zinc in the presence of 100-fold excesses of calcium and magnesium

zinc. This is difficult to explain because quantitative results were obtained in the separation of equal molar amounts of copper and these ions. Hydrolysis of these ions when they are in high concentrations could be the cause of the problem.

E. Sorption of Anions

When studying the retention of several metal ions on the tetramine resin, it was noted that copper(II), zinc(II), cobalt(II), cadmium(II), nickel(II) and iron(III) were all sorbed from an eluent stream of pH 7 acetate buffer that was 10^{-3} M in sodium tartrate. It was also noted that the iron(III)-tartrate complex was sorbed from pH 5 acetate buffer. This behavior might be explained by the fact that the amine-metal ion complexes are stronger than the tartrate metal ion complexes. There is also the possibility that the resin is functioning as an anion exchange resin. The pK_a values for triethylenetetramine have been reported to be 3.3, 6.7, 9.2 and 9.9, which would indicate that the resin should be in the hydrogen form at pH values of approximately 10 or less (87). Therefore, the resin should function as an anion exchange resin at pH values of less than 10 and could retain anionic tartrate complexes at pH 7 and at pH 5.

To gain a better understanding of the mechanism of the resin-ion complexation, the retention of the chromium tartrate and dichromate anions were studied at several

conditions. The results of these studies are summarized in Table 15.

Table 15. Affinity of tetramine resin for chromium tartrate and dichromate

Eluent	Chromium tartrate	Dichromate
pH 10 ammonia buffer	E ^a	E
pH 8 ammonia buffer	R ^b	R
pH 5 acetate buffer	R	R
pH 3 HClO ₄	R	R
pH 2 HClO ₄	R	R
pH 1 HClO ₄	E	R
pH 0 HClO ₄	E	Precipitates

^aE = Eluted.

^bR = Retained.

The retention of chromium tartrate at pH 2, pH 3, pH 5, pH 8 and dichromate at pH 1, pH 2, pH 3, pH 5 and pH 8 would indicate that the resin is working as an anion exchange resin, because at these pH values the resin is probably in the hydrogen form. At pH 10 the resin is probably in the basic form and can no longer function as an anion exchange

resin, and the anions are eluted. The elution of chromium tartrate at pH 0 and pH 1 is probably due to the instability of the tartrate complex at these low pH values and the slow kinetics of the formation of chromium(III)-amine complex would prevent the formation of a chromium(III)-amine chelate on the resin.

F. Preparation of Higher Capacity Resins

Because the tetramine resin is very selective for copper, it could be very useful for batch extractions of copper. However, the resin prepared on XAD-4 did not have a high enough capacity to make such extractions economically feasible. Therefore, resins of higher capacity were prepared with a commercial chloromethylated resin that was only 1% cross-linked with divinylbenzene (Biorad SX-1). This resin contained 4.5 meq of chlorine per gram of resin. Several different conditions for the synthesis were attempted to obtain a resin with maximum capacity. Table 16 summarizes the different procedures used to prepare such a resin, and the copper capacities of these resins at pH 5 are given.

These data indicate that it is important to allow the resin to swell and to allow the amine to get into the resin matrix for the maximum capacities. The resin with the highest copper capacity is comparable with the resin prepared by Egawa and Saeki (8) who allowed a 0.5% cross-linked chlormethylated resin to swell overnight in benzene and then

Table 16. Synthesis of low cross-linked triethylenetetraamine

Resin #	g Resin	ml Amine	Solvent	ml Solvent	Conditions	Cu capacity pH 5 (mmole/g)
1	10	28	Benzene	200	Resin swelled in 150 ml benzene 3 hrs. Amine added, stirred 1 hr, refluxed 3 hrs.	1.03
2	---	---	---	---	Resin soaked in XS amine 30 hrs.	0.054
3	1	5	Benzene	50	Reflux 4 hrs.	0.559
4	1	5	DMF	50	Reflux 2 hrs.	0.00
5	1	5	Benzene	50	Swell resin overnight. Add amine and reflux for 4 hrs.	1.08
6	1	5	Benzene	20	Swell resin 1 hr. Add amine. Reflux 4 hrs.	0.716
7	1	5	Benzene	20	Swell resin overnight. Add amine. Reflux 4 hrs.	0.896
8	1	20	Benzene	20	Let mixture stand overnight. Reflux 4 hrs.	1.67
9	1	5	Benzene	50	Let mixture stand 24 hrs. Reflux 4 hrs.	1.45

added 2-14 volume percentages of amine, capped and heated the solution at 100°C for 2 hours. They prepared a resin that had a copper capacity of about 1.5 meq/g at pH 5.

G. Conclusions

The tetramine resin has proven to be very selective for copper(II), silver(I) and mercury(II) at low pH values. The resin is useful for the rapid separation and determination of copper(II) in the presence of large excesses of many other transition metals. However, the method does not have the accuracy of the determination of copper by electrodeposition. The resin is also very useful for the separation of heavy metals from large excesses of alkaline earth metals. Preliminary studies indicate that the resin could be very useful for the selective concentration of trace amounts of silver(I) and mercury(II) from aqueous solution. Also, further work could prove the resin to be useful for the separation of many anionic species.

Preparation of the tetramine resin with polystyrene gel rather than XAD-4 produced resins with significantly higher capacities for copper. However, the capacities of these resins still were not high enough to make the resin useful for batch extraction of copper. The reason for the low capacities could be due to cross-linking of the tri-ethylenetetramine between the phenyl group of the polymer.

Preparation of an ethylenediamine resin with the low cross-linked polystyrene could produce a resin with sufficient capacity for batch copper extraction with some loss in selectivity.

VI. LITERATURE CITED

1. J. S. Fritz and G. M. Orf, *Anal. Chem.*, 47, 2043 (1975).
2. H. M. Feder and M. Ader, Solvent Extraction of Uranium Values, U.S. Patent 2,872,285 (1959).
3. W. H. Baldwin, C. E. Higgins, and J. M. Schmitt, Chem. Div. Ann. Prog. Rept. ORNL-3679,56 (1964).
4. J. Kennedy, *Chem. and Ind.*, 1956, 378 (1956).
5. E. J. Shepherd and J. A. Kitchener, *J. Chem. Soc.*, 1957, 86 (1957).
6. S. Nonabaki, S. Makishima and Y. Yoneda, *J. Phys. Chem.*, 62, 601 (1958).
7. V. D. Kopylova, K. M. Saldadze, and G. D. Asambadze, *Zh. Anal. Khim.*, 26, 31 (1971).
8. H. Egawa and H. Saeki, *Kogyo Kagaku Zasshi*, 74, 772 (1971).
9. K. D. Saldadze, V. V. Kargman, V. D. Kopylova and T. P. Launa, *Zh. Anal. Khim.*, 27, 246 (1972).
10. J. Dingman, Jr., S. Siggia, C. Barton, and K. B. Hiscock, *Anal. Chem.*, 44, 1351 (1972).
11. D. E. Leyden, T. A. Patterson, and J. J. Alberts, *Anal. Chem.*, 47, 733 (1975).
12. D. E. Leyden and G. H. Luttrell, *Anal. Chem.*, 47, 1612 (1975).
13. L. R. Melby, *J. Am. Chem. Soc.*, 97, 4044 (1975).
14. H. Erlenmeyer and H. Dahn, *Helv. Chim. Acta*, 22, 1369 (1939).
15. R. Griessbach, *Z. Ver. dtsh. Chem.*, Beiheft No. 31 (1939).
16. A. Skogseid, Thesis, Oslo (1948).
17. D. K. Hale, *Research*, 9, 104 (1956).

70. F. Vernon and H. Eccles, *Anal. Chim. Acta*, 63, 403 (1973).
71. G. Schmuckler, *Talanta*, 10, 745 (1963).
72. V. D. Kopylova, K. M. Saldadze, and G. D. Asambadze, *Russ. J. Inorg. Chem.*, 15, 549 (1970).
73. M. D. Seymour, Ph.D. Thesis, Iowa State University, Ames, IA (1972).
74. L. Goodkin, Ph.D. Thesis, Iowa State University, Ames, IA (1974).
75. M. D. Arguello, Ph.D. Thesis, Iowa State University, Ames, IA (1977).
76. S. B. Savvin, *Talanta*, 8, 673 (1961).
77. J. N. Story, Ph.D. Thesis, Iowa State University, Ames, IA (1973).
78. J. S. Fritz and M. J. Richard, *Anal. Chim. Acta*, 20, 164 (1959).
79. J. Falbe, R. Paatz, and F. Korte, *Berichte*, 97, 2544 (1964).
80. A. Steyermark, Quantitative Organic Microanalysis, The Blakistan Company, New York, 1961, p. 56.
81. W. F. Hildebrand, G. E. F. Lundell, H. A. Bright, and J. I. Hoffman, Applied Inorganic Analysis, 3rd ed., John Wiley and Sons, New York, 1953, p. 453 and 465.
82. J. S. Fritz, J. E. Abbink, and M. A. Payne, *Anal. Chem.*, 33, 1381 (1961).
83. Permutit Co. Ltd., *Brit.* 816,583, July 15, 1959; *Chem. Abst.*, 53, 230791 (1959).
84. K. W. Cheng, *Microchem. J.*, 3, 537 (1959).
85. J. Bjerrum, G. Schwarzenbach, and L. G. Sillen, Stability Constants, Part I, The Chemical Society, London, 1957.
86. H. B. Jonassen, G. G. Hurst, R. B. LeBlanc, and A. W. Meibohm, *J. Phys. Chem.*, 56, 16 (1952).

87. D. D. Perrin, Organic Complexing Reagents: Structure, Behavior, and Applications to Inorganic Analysis, in Chemical Analysis, Edited by P. J. Elving and I. M. Kolthoff, Interscience Publishers, New York, 1964, Vol. XVIII, p. 116.

VII. ACKNOWLEDGEMENTS

The author wishes to thank Professor James S. Fritz for his helpful advice and guidance throughout the course of this work.

I would also like to thank John Richard and Gary Austin for the elemental analysis of the resins and Mike Gaul for his help in the synthesis of the amide resin.