

A MAGNETIC BEAM POSITION MONITOR*

J. Claus
Brookhaven National Laboratory
Upton, New York

Summary

We give the theory and describe the execution of the magnetic beam position monitors in use in the AGS injection line. These are strictly linear devices of very low impedance with a rise time of the order of 1 μ sec. They do not require electronics close to the device and have been constructed to withstand considerable radiation. Their construction is simple and not critical.

Introduction

The beam transport system between the 200-MeV injection linac and the Alternating Gradient Synchrotron at Brookhaven National Laboratory contains 18 non-destructive beam position monitors (PM's) with which the transverse position of the beam with respect to some fixed coordinate system may be determined during normal operation. Sixteen of these are arranged in groups of 4, each group yielding values for the 4 coordinates of the beam axis in transverse phase space. Two others are placed at points of high dispersion in bends and used to measure the momentum error averaged with the beam. Our purpose is to describe these PM's.

Design Considerations

Our prime goal is a PM with a resolution of ≤ 0.1 mm for the center of charge of proton beams with beam currents between 10 and 100 μ A, bunched at 200 MHz, independent of charge distribution or bunching factor. Signal rise times should be short compared to the AGS revolution period of 4.75 μ sec, we chose 1 μ sec. Sensitivity to beam current was preferred above sensitivity to beam charge because this gives a measure of discrimination against low energy rest gas ions. A low impedance was thought desirable because this should reduce problems associated with charge accumulation due to rest gas ions or direct hits.

The device was to be cheap, mechanically simple and maintenance free. It should not require electronics in radiation areas, so that that equipment may be serviced independent of the operational status of the accelerator.

Solution

The monitors that finally evolved may be regarded as a development of a surveying device used at SLAC.¹ It is a magnetic dipole structure formed of a single turn pick-up loop (a structure brazed of 3 mm thick sheet copper) inside a ferrite picture frame yoke (Fig. 1). A beam passing asymmetrically through the aperture develops a signal in the pick-up loop that is proportional to beam current and beam offset, a current through the loop bends the beam as any bending magnet does. The signal is sent to the electronic equipment via a matching transformer and a shielded twisted pair. The transformer is an integral part of the device and has a passband that cuts off beyond 4 MHz, so that the "dc" component of the signal is passed unharmed but its 200 MHz structure is lost.

Linearity and Sensitivity

It is well known that any position monitor will

*-Work done under the auspices of the U.S. AEC.

detect the location of the center of charge if it has a linear characteristic of response. Since our beam dimensions are not necessarily small compared to the aperture we paid special attention to that linearity. There are several proofs for the statement that the response will be linear if the device, when operated as a bending magnet, produces a perfect dipole field; i.e., $\int_{-\infty}^{\infty} B dl$ independent of transverse location. One, for which I am indebted to Dr. R.A. Beth, is particularly nice. It depends on the bidirectionality of the mutual inductance of two coils. If the field produced by the pick-up coil when driven by a current yields a perfect dipole the signal induced in a long search coil is independent of the latter's transverse location. Therefore its mutual inductance with the pick-up coil is position independent. Dr. Beth remarked that this leads to a simple bench test for linearity: demonstrate that independence of transverse position experimentally.

Part of the magnetic flux generated by an excited pick-up coil returns to the left, the remainder to the right of a dividing plane in the air gap parallel to the field's direction (Fig. 2). It is easy to show that the mutual inductance of a pencil beam and the pick-up coil is linearly proportional to the distance of that beam (averaged over the effective length of the device) to that dividing plane. But then the signal induced by that beam in the pick-up coil must be proportional to that averaged distance also. In formulae:

$$M = \mu_0 \frac{lx}{g} (4nH/mm)$$

$$L = \mu_0 \frac{lw}{g} (300 nH)$$

$$\frac{e_s}{e_b} = \frac{d}{dt} (Mi) = \mu_0 \frac{l}{g} \left(4 \frac{d(xi)}{dt} \mu V \right)$$

Here M is the mutual inductance, L the self-inductance of and $\frac{e_s}{e_b}$ the signal induced in the pick-up coil. l (~ 24 cm) is the effective length of the device, w (~ 7.5 cm) its width and g (~ 7.5 cm) its gap height. x represents the distance to the dividing plane and i the beam current. The numbers in brackets apply to a typical example at BNL. These formulae assume that the reluctance of the path through the ferrite is negligible compared to that of the air gap, permissible if the permeability of the ferrite is sufficiently high (in our case ~ 300) and the ferrite cross section not too small. It may be seen that the device acts as a beam transformer whose coupling factor to the beam depends upon the beam position.

Transformer

The beam signal on the pick-up coil is transported to the electronic equipment, which is installed in a radiation-free area via a transformer and a long cable. The transformer serves several functions:

- 1) It separates the pick-up coil galvanically from the signal circuit, so that the coil may be grounded locally without causing ground loop problems,
- 2) the secondary winding floats, so that the cable and electronics may be run balanced to ground; this reduces common mode noise,
- 3) it acts as a filter, passing the "dc" component of the signal but stopping its very pronounced 200 MHz

MASTER

DISTRIBUTION OF THIS DOCUMENT IS UNLIMITED

Jeg

- 3) bunching structure,
- 4) it causes some partial integration, reducing thereby the high frequency content of the "dc" signal and the high frequency requirements on cable and electronics.

It consists of a tape wound toroidal core of 0.025 mm supermalloy tape (Arnold part number 4T-4635-S1) wound with a secondary winding and housed in a toroidal copper can with a cylindrical capacitive gap (Fig. 3). The gap is filled with epoxy, making the can vacuum tight. The inductance of the can resonates with the capacitance of the gap at about 4 MHz. Signal components with frequencies below 4 MHz will primarily flow through the inductance, pass through the aperture of the toroid and couple with the secondary winding while signal components beyond 4 MHz will pass through the capacitance and not couple to the secondary. The primary winding is formed by a stem through the center of the toroid. Together with the pick-up coil it forms a closed loop with inductance L of 0.3 μH and a resistance r_p of 40 $\mu\Omega$. (Transformer secondary shorted.) The inductance of a single transformer turn is 5 μH , thus its coupling inductance is much larger than the inductance of the pick-up loop. The number of secondary turns, i.e., the transformer turns ratio n is chosen to suit the purpose. Below the break point frequency $\omega_{bp} = (Z_0/n^2 + r_p)/L$ the transfer function from beam to cable is given by $e_{sc1} = nL \frac{d}{dt} (xi/w)/(1 + n^2 r_p/Z_0)$, above it by $e_{sc2} = Z_0 xi/(nw)$ and above the resonant frequency of the can $e_{sc3} \approx 0$.

For $Z_0/nl \gg r_p$ this reduces to

$$\bar{\omega}_{bp} = Z_0/(Ln^2)$$

$$\bar{e}_{sc1} = nL \frac{d}{dt} \left(\frac{xi}{w} \right)$$

$$\bar{e}_{sc2} = Z_0 xi/(nw) .$$

From this it may be seen that increasing n reduces the break point frequency, and the sensitivity beyond that frequency. E.B. Forsyth pointed out that the signal to noise ratio is improved if the integration necessary to obtain a signal proportional to xi is performed as a final step because then all the noise in the system is integrated also and thereby reduced in magnitude. This is equivalent with choosing ω_{bp} high and consequently n low. ω_{bp} should not be chosen too high however to prevent taxing the high frequency response of cable and electronics too severely. At present we have $\omega \approx 2\pi \cdot 0.50 \times 10^8$ rad/sec. This makes the cable voltage of the order of 100 μV at minimum resolution. The noise of the cable must be developed across the transformed r_p , i.e., $\approx 1 \Omega$.

Electronics

The electronics equipment consists of conventional operational amplifiers, used as amplifiers and gated integrators. The integrator should act as integrator for $0 < \omega < \omega_{bp}$ and as amplifier for $\omega > \omega_{bp}$. A prime problem has been zero drift of the integrators, causing triangular waveforms even with no beam present. The problem has been partly cured by amplifier selection. Automatic compensation is under consideration.

Additional Considerations

Although the permeability of the ferrite should be high, it should not be too high in order to prevent magnetic saturation of the yoke by the beam current. If this unlikely problem occurs, the yoke may be pro-

vided with a thin gap in the magnetic symmetry plane mentioned above.

In principle the beam is steered by the dipole field set up by the current in the pick-up loop. At worst this current equals half the beam current. In our case the dipole field would be $\int B dl = 2 \times 10^{-8}$ Tm per ampere of beam current or 10^{-8} rad/A per monitor.

Practical Experience

Our PM appear to behave to within a few percent as calculated. In particular the linearity as measured with a current in a sketched copper wire remains with a few tenth's percent to the edges of the aperture. This result was our accuracy limit.

We cannot state that our design goal has been reached. Because the performance is more than adequate for our present needs, the electronics have not yet been fully developed, nor have the cables been installed in seamless metal conduit, essential to reduce interference from external sources to a minimum. All monitors contain a sketched calibration wire in one corner of the aperture.

Acknowledgment

Special thanks are due to Dr. F.E. Mills for a mathematical proof of the relation between uniformity and linearity and to R.H. Larson, A. Otis, E.B. Forsyth, and R.E. Lockey for their parts in this project.

Reference

1. W.K.H. Panofsky and W.F. Marshall, "The Use of a Magnetic Pick-up as an Alignment Indicator With a Stretched Wire Technique", SLAC Rep. TN-65-74, September 1965.

NOTICE

This report was prepared as an account of work sponsored by the United States Government. Neither the United States nor the United States Atomic Energy Commission, nor any of their employees, nor any of their contractors, subcontractors, or their employees, makes any warranty, express or implied, or assumes any legal liability or responsibility for: the accuracy, completeness or usefulness of any information, apparatus, product or process disclosed, or represents that its use would not infringe privately owned rights.

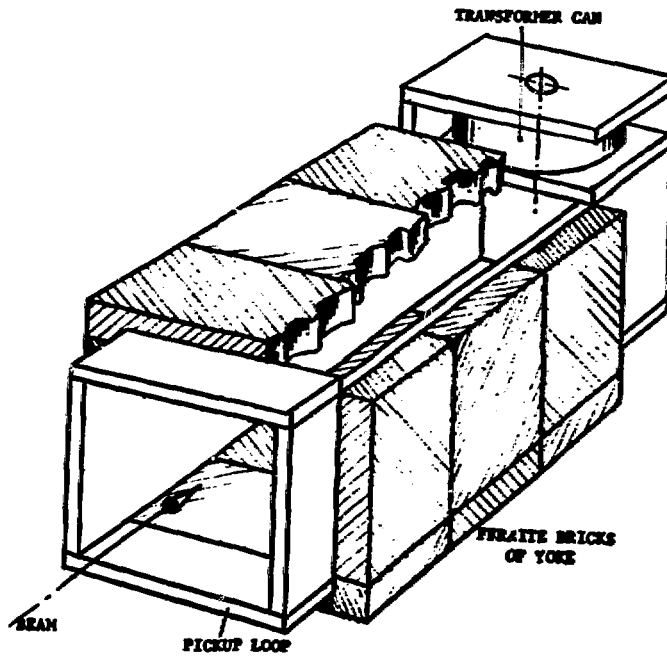

Fig. 1. Magnetic Position Monitor (right hand part of top bricks left off to show interior).

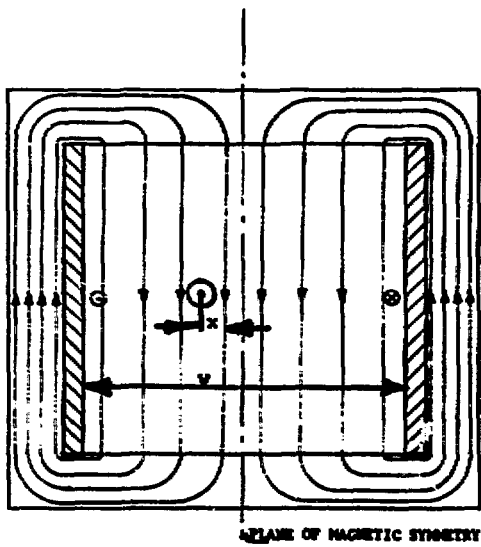

Fig. 2. Dipole Field.

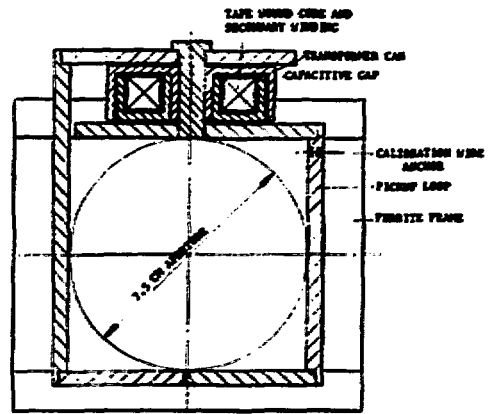

Fig. 3. Section Through Transformer.