

WT-1509

AEC Category: HEALTH AND SAFETY  
Military Category: 28

OPERATION  
**PLUMBBOB**

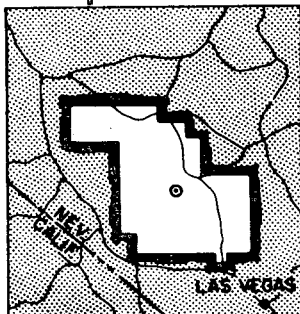

NEVADA TEST SITE  
MAY-OCTOBER 1957

Project 39.9

REMOTE RADIOLOGICAL MONITORING

Issuance Date: May 1, 1959

CIVIL EFFECTS TEST GROUP

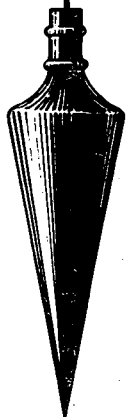

401 601

## NOTICE

This report is published in the interest of providing information which may prove of value to the reader in his study of effects data derived principally from nuclear weapons tests.

This document is based on information available at the time of preparation which may have subsequently been expanded and re-evaluated. Also, in preparing this report for publication, some classified material may have been removed. Users are cautioned to avoid interpretations and conclusions based on unknown or incomplete data.

Price \$2.25. Available from the Office of  
Technical Services, Department of Commerce,  
Washington 25, D. C.

402 002

## **DISCLAIMER**

**This report was prepared as an account of work sponsored by an agency of the United States Government. Neither the United States Government nor any agency Thereof, nor any of their employees, makes any warranty, express or implied, or assumes any legal liability or responsibility for the accuracy, completeness, or usefulness of any information, apparatus, product, or process disclosed, or represents that its use would not infringe privately owned rights. Reference herein to any specific commercial product, process, or service by trade name, trademark, manufacturer, or otherwise does not necessarily constitute or imply its endorsement, recommendation, or favoring by the United States Government or any agency thereof. The views and opinions of authors expressed herein do not necessarily state or reflect those of the United States Government or any agency thereof.**

## **DISCLAIMER**

**Portions of this document may be illegible in electronic image products. Images are produced from the best available original document.**

**Report to the Test Director**

# **REMOTE RADIOLOGICAL MONITORING**

By

S. C. Sigoloff

and

H. M. Borella

Approved by: **R. L. CORSBIE**  
Director, Program 39  
Director, Civil Effects Test Group

Division of Biology and Medicine  
U. S. Atomic Energy Commission  
November 1958

402 003

L

## ABSTRACT

A gamma-radiation telemetering system was utilized by Civil Effects Test Group personnel to measure fallout levels at the Nevada Test Site from the vicinity of Ground Zero out to, and including, an area bounded by Reno, Nev.; Salt Lake City, Utah; Kingman, Ariz.; and Barstow, Calif. Two methods of signal transmission were used: direct-coupled field lines for on-site installations and commercial telephone lines for areas out to 330 miles.

Graphic and tabular data cover on-site and off-site residual gamma-radiation dose rate measurements taken as a function of time after selected events.

## ACKNOWLEDGMENTS

The authors are indebted to the following members of the project whose assistance and keen interest made the successful field operations possible:

C. Amandon, Reynolds Electrical & Engineering Co., Inc.  
H. O. Cline, National Bureau of Standards  
Louis Costrell, National Bureau of Standards  
R. L. Darneal, U. S. Atomic Energy Commission  
W. Dawson, Reynolds Electrical & Engineering Co., Inc.  
R. W. Johnston, U. S. Atomic Energy Commission  
R. Stadlander, Reynolds Electrical & Engineering Co., Inc.  
D. Stewart, Reynolds Electrical & Engineering Co., Inc.

Of equal significance to any project are those whose encouragement, advice, and specialized abilities contributed to the objectives. In this respect the authors express their appreciation to the following:

G. Barrows, U. S. Atomic Energy Commission  
R. L. Corsbie, U. S. Atomic Energy Commission  
L. J. Deal, U. S. Atomic Energy Commission  
L. C. Logie, U. S. Air Force, School of Aviation Medicine  
E. R. Saunders, Federal Civil Defense Administration  
W. Thompson, Reynolds Electrical & Engineering Co., Inc.



## CONTENTS

ABSTRACT . . . . .	5
ACKNOWLEDGMENTS . . . . .	6
1 INTRODUCTION . . . . .	11
2 INSTRUMENTATION . . . . .	11
3 PROCEDURE . . . . .	12
3.1 On-site Operations . . . . .	12
3.2 Off-site Operations . . . . .	12
4 RESULTS . . . . .	12
4.1 Installation and Maintenance of Equipment . . . . .	12
4.2 On-site Results . . . . .	12
4.3 Off-site Results . . . . .	13
5 SUMMARY . . . . .	13
REFERENCES . . . . .	13
APPENDIX A REMOTE RADIATION-MONITORING SYSTEM . . . . .	47
APPENDIX B PROJECT 39.9 MAINTENANCE REPORT . . . . .	85

## ILLUSTRATIONS

1 Effect of 1000 Rep of Neutrons on RDS-1A (No. 8) and LR Detector No. 26 . . . . .	14
2 Decay Pattern for Project 4.1 and Project 30.2, Shot Priscilla . . . . .	15
3 Decay Pattern Outside Program 33 Blast Shelter, Shot Kepler . . . . .	16
4 Decay Pattern for Project 39.5 Recovery Route, Area T-2c, South Line, 400 Yd, Shot Smokey . . . . .	17
5 Decay Pattern for Butler Building, Center Forward, Shot Shasta . . . . .	18
6 Decay Pattern for Butler Building, Right Aft, Shot Shasta . . . . .	19
7 Decay Pattern for Butler Building, Left Aft, Shot Shasta . . . . .	20
8 Decay Pattern for Butler Building, Inside, Shot Shasta . . . . .	21
9 Decay Pattern for Project 32.3 Manned Shelter, Right Pad, Shot Shasta . . . . .	22
10 Decay Pattern for Project 32.3 Manned Shelter, Left Pad, Shot Shasta . . . . .	23
11 Decay Pattern for Project 32.3 Manned Shelter, Center Pad, Shot Shasta . . . . .	24
12 Decay Pattern for Butler Building, Center Forward, Shot Diablo . . . . .	25
13 Decay Pattern for Butler Building, Right Aft, Shot Diablo . . . . .	26
14 Decay Pattern for Butler Building, Left Aft, Shot Diablo . . . . .	27

## ILLUSTRATIONS (Continued)

15	Decay Pattern for Butler Building, Inside, Shot Diablo . . . . .	28
16	Decay Pattern for Project 32.3 Manned Shelter, Right Pad, Shot Diablo . . . . .	29
17	Decay Pattern for Project 32.3 Manned Shelter, Left Pad, Shot Diablo . . . . .	30
18	Decay Pattern for Project 32.3 Manned Shelter, Center Pad, Shot Diablo . . . . .	31
19	Decay Pattern for Projects 39.5 and 39.6 Recovery Route, Area T-3b, 1000 Yd, Shot Fizeau . . . . .	32
20	Decay Pattern for Projects 39.5 and 39.6 Recovery Route, Area T-3b, 1250 Yd, Shot Fizeau . . . . .	33

### APPENDIX A

1	Typical Radiation-monitoring Station Installation . . . . .	61
2	Radiation-monitoring Station (Without Detectors) . . . . .	62
3	Control Station . . . . .	63
4	Typical Read-out Tape . . . . .	64
5	Radiation-monitoring Station Showing Batteries, Remote Data Station, and Ring Box . . . . .	64
6	Remote Data Station, Front View . . . . .	65
7	Remote Data Station, Rear View . . . . .	65
8	Remote Data Station Showing How Unit Is Disassembled by Removing Front Panel and Rear Cover . . . . .	66
9	Voltage Divider Networks for Remote Data Stations . . . . .	67
10	Battery Box Showing High-voltage Supply Mounted on Partition . . . . .	68
11	Ring Box for Use with Telephone Lines . . . . .	69
12	Detectors and Integrators . . . . .	70
13	Detector Circuits . . . . .	71
14	Calibration Jig in Place for Calibration of VLR Detector . . . . .	71
15	Typical Detector Calibration Curves . . . . .	72
16	Radiation-monitoring Switchboard . . . . .	73
17	Multiple-station Selector for Operation of Several Radiation-monitoring Stations over a Single Pair of Field Lines . . . . .	73
18	Radiation-monitoring Switchboard Circuit Diagram . . . . .	74
19	Remote Data Station RDS-1A . . . . .	75
20	Calibration Source Containers . . . . .	76
21	Oscillator Stability . . . . .	77
22	Line Terminating Equipment, Remote Station . . . . .	78
23	Line Terminating Equipment, Control Station . . . . .	78
24	Battery Wiring for Remote Data Station RDS-1A . . . . .	79
25	Voltage-Current Characteristics of BS-1 Counter Tube . . . . .	80
26	Energy and Directional Response of LR Detectors to Gamma Radiation . . . . .	81
27	Energy and Directional Response of VLR Detectors to Gamma Radiation . . . . .	82

### TABLES

1	On-site Remote Radiological Monitoring Station Locations (Counter- measures Studies) . . . . .	34
2	On-site Remote Radiological Monitoring Station Locations (Early Recovery Studies) . . . . .	34
3	Off-site Remote Radiological Monitoring Station Locations . . . . .	35
4	Off-site Fallout Data (Shot Boltzman) . . . . .	36
5	Off-site Fallout Data (Shot Priscilla) . . . . .	37
6	Off-site Fallout Data (Shot Kepler) . . . . .	38
7	Off-site Fallout Data (Shot Smokey) . . . . .	39
8	Off-site Fallout Data (Shot Shasta) . . . . .	40

## TABLES (Continued)

9	Off-site Fallout Data (Shot Fizeau)	. . . . .	41
10	Off-site Fallout Data (Shot Newton)	. . . . .	42
11	Off-site Fallout Data (Shot Whitney)	. . . . .	42
12	Off-site Fallout Data (Shot Charleston)	. . . . .	43
13	On-site Monitoring (Shot Whitney)	. . . . .	43
14	Comparative Radiation Intensity Readings (Shot Diablo)	. . . . .	45
15	Comparative Radiation Intensity Readings (Shot Shasta)	. . . . .	45

### APPENDIX A

1	Detector Calibrations for SR, MR, SB, and MB Sources	. . . . .	60
2	Adjustment Procedure for Remote Data Station RDS-1A	. . . . .	60



# REMOTE RADIOLOGICAL MONITORING

## 1 INTRODUCTION

The advantages of a remote system for radiologically monitoring areas that might be contaminated by radiation fallout and/or induced activity have been under consideration for some time. Two of the most important advantages of such a system are: (1) the reduction in, or elimination of, the exposure to personnel needed to assess the degree of contamination and (2) the more efficient collection of larger amounts of radiological data in a shorter time.

A wire-controlled radiation telemetering system<sup>1</sup> was employed by the National Bureau of Standards (NBS) for on-site measurement of gamma rate as a function of time during Operation Buster-Jangle in the fall of 1951. This activity was sponsored by the Armed Forces Special Weapons Project.

During Operation Upshot-Knothole in the spring of 1953, a radio-controlled telemetering system,<sup>2</sup> designed by NBS and Motorola, Inc., for the U. S. Atomic Energy Commission, was tested. The results of these tests demonstrated the feasibility of remote radiological monitoring.

A wire-controlled unit was designed for Operation Teapot<sup>3</sup> (see also Appendix A) utilizing the experience gained at previous operations. This remote data-station unit, designated as RDS-1, had provision for adaptation to commercial telephone lines and provided a relatively inexpensive and reliable method for covering areas close to Ground Zero (GZ) as well as the off-site communities adjacent to the Nevada Test Site (NTS).

### Objectives

As a result of the field experience gained in Operation Teapot, the remote data-station units were modified and designated as RDS-1A units. These modified units were used in Operation Plumbbob to meet the following specific objectives:

1. On-site measurement by direct-coupled field-line stations of residual gamma activity in, or adjacent to, structures being studied by various Civil Effects Test Group (CETG) projects and immediate measurements on radiation levels for use by postshot recovery parties.

2. Off-site measurements of gamma activity were made, utilizing telephone-controlled stations, in 30 selected communities ranging in distance from 50 to 300 miles from NTS (Table 3).

In addition to the above, CETG personnel also had the following objectives in mind regarding the equipment per se: (1) to determine operational limitations and the effect these limitations might have on present and future field use (NTS) of the equipment; (2) to obtain, under severe field conditions, information that would adequately describe design criteria for new and/or restyled remote radiological-monitoring equipment; and (3) to ascertain the reliability of telemetered radiological data using comparative techniques.

## 2 INSTRUMENTATION

The equipment and its operation are described in NBS Report 5471, Remote Radiation-Monitoring System (see Appendix A).

### 3 PROCEDURE

#### 3.1 On-site Operations

Direct-coupled field-line remote data stations were located at various distances from GZ for 13 shots. The locations (see Tables 1 and 2) for each shot were in, or adjacent to, structures being studied by various CETG projects and were selected on the basis of the early recovery requirements of these projects. After each detonation these stations were challenged at various time intervals to determine the radiation intensity. These data were used to ascertain Rad-Safe routes suitable for early recovery in hot areas and to determine the time of recoveries and the necessity for countermeasures.

#### 3.2 Off-site Operations

Telephone-controlled RDS-1A units with plug-in ring boxes were installed in the 30 communities listed in Table 3. Placement of the off-site stations was based on the fallout patterns from previous tests as well as on population density. The stations were generally located in such a manner as to supplement the manned teams of off-site Rad-Safe. Stations were challenged postshot according to their proximity to NTS, as described by the predicted fallout pattern at shot time. Frequency of challenge and station selection were dictated by the activity reported. All off-site stations were routinely challenged for every event, even in areas where no fallout was predicted.

### 4 RESULTS

#### 4.1 Installation and Maintenance of Equipment

Technicians were assigned to install and maintain the equipment used on this project. At the request of CETG, Reynolds Electrical & Engineering Co., Inc., prepared a report based on the experience of these technicians; this report is included in this report as Appendix B.

#### 4.2 On-site Results

For shots Diablo, Shasta, and Whitney the RDS-1A units were located in areas where the initial radiation was negligible and where the residual radiation was expected to be high (see Table 1). Significant fallout was received in these areas on shots Diablo and Shasta; low-intensity fallout was found on shot Whitney.

Figures 2 to 20 show the decay patterns obtained with the RDS-1A equipment for close-in fallout. Table 13 shows the fallout recorded on the two Butler buildings exposed on shot Whitney.

When the radiation intensities decreased to a permissible entry level, comparative readings were made adjacent to the field stations with Juno meters and Rad-Safe T-1b meters. As shown by the comparative data in Tables 14 and 15, the agreement between instruments is very acceptable.

Use of the RDS-1A units on shots Diablo, Shasta, and Whitney verifies the fact that acceptable radiation-intensity data can be collected by telemetering techniques.

When the telemetering system was designed for Operation Upshot-Knothole, there were no plans for close-in use in which there would be exposure to large neutron doses. Since these detectors, halogen-quenched G-M counters, have stainless-steel walls, they can be neutron activated. This severely limits close-in operations. Neutron activation of the tubes was first observed during Operation Teapot. Again, during this series, this effect limited the usefulness of the system in areas of high neutron fluxes. Quantitative results of neutron activation are shown in Fig. 1. The detector was exposed to 1000 rep of neutrons, after which it was removed from the field to an area of normal background where successive calibration runs were made at 8, 36, and 48 hr after exposure. These curves are compared to the original calibration curve made prior to the activation.

402 010

### 4.3 Off-site Results

Tables 4 to 15 list, by event and time of challenge, the radiation intensities deemed valid and within the range of capability afforded by the detector.

Equally as important as the significant data listed in Tables 4 to 15 are the unlisted "insignificant" data. Radiation intensities too low to be measured by the units imply that the fallout, if in existence, was less than a given level, namely, 0.3 mr/hr. These negative reports aided in describing the fallout history for a given event and served as valuable cross checks for other data-collection units and programs.

### 5 SUMMARY

1. The value of a remote radiation telemetering system was again demonstrated.
2. On-site direct-coupled field-line RDS-1A units provided radiological data that aided in the postshot recovery operations of CETG projects and helped minimize radiation exposure in contaminated areas.
3. Telephone-controlled RDS-1A units, installed off-site, provided data that can be used in documenting the radiation intensities experienced in the surrounding communities.
4. Information obtained on the installation, maintenance, and operation of the RDS-1A units provided guidance for improvement in design of future equipment.
5. Comparative field measurements indicated that reliable radiation-intensity data can be collected by telemetry techniques.

### REFERENCES

1. Louis Costrell, Gamma Radiation as a Function of Time and Distance, Operation Buster-Jangle Report, WT-329.
2. R. W. Johnston, Test of a Radiation Telemetering System, Operation Upshot-Knothole Report, WT-796, August 1953.
3. R. W. Johnston, Utilization of Telemetering Techniques in Evaluating Residual Radioactive Contamination, Operation Teapot Report, WT-1182.

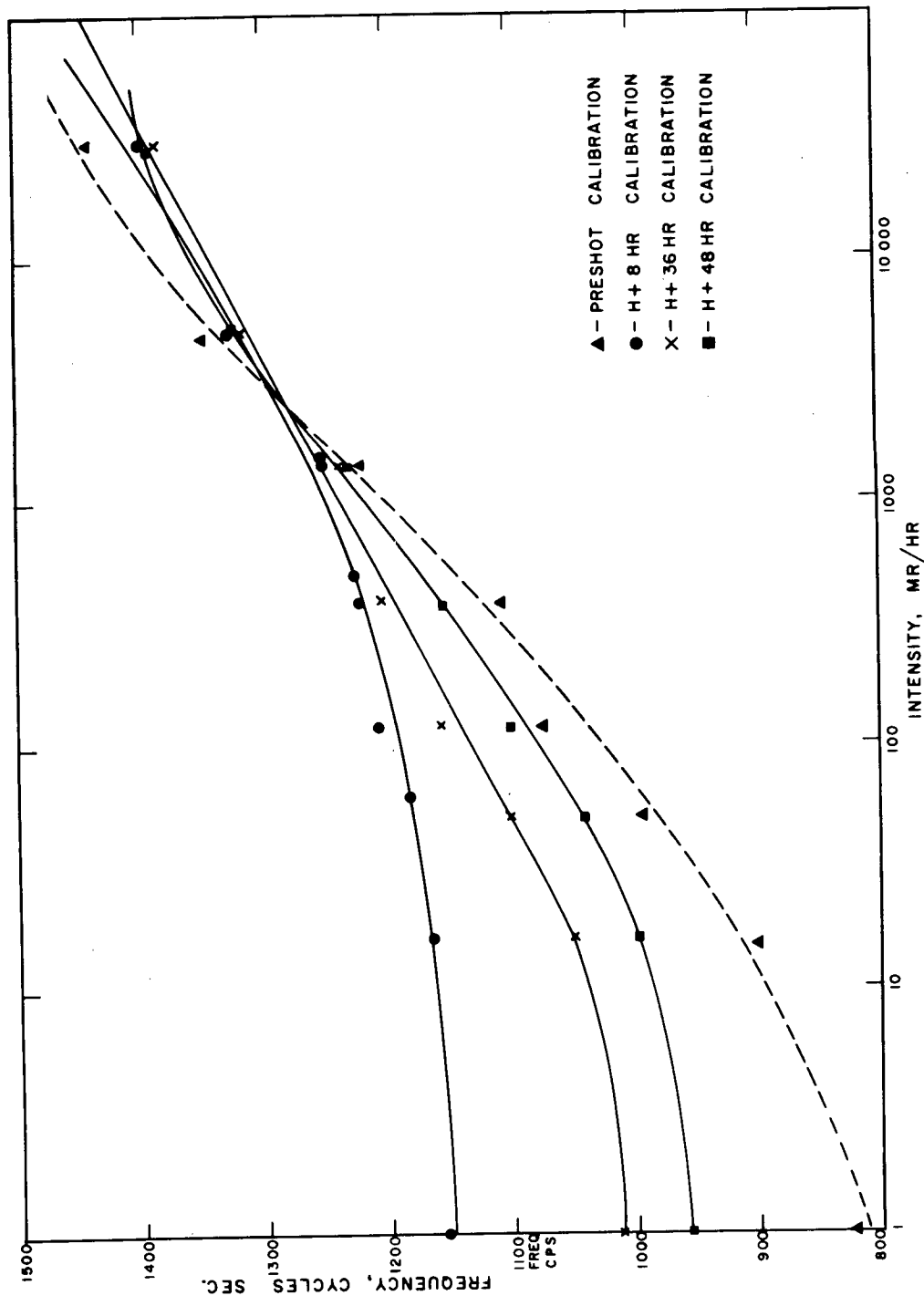

Fig. 1 — Effect of 1000 rep of neutrons on RDS-1A (No. 8) and LR detector No. 26.

402 012



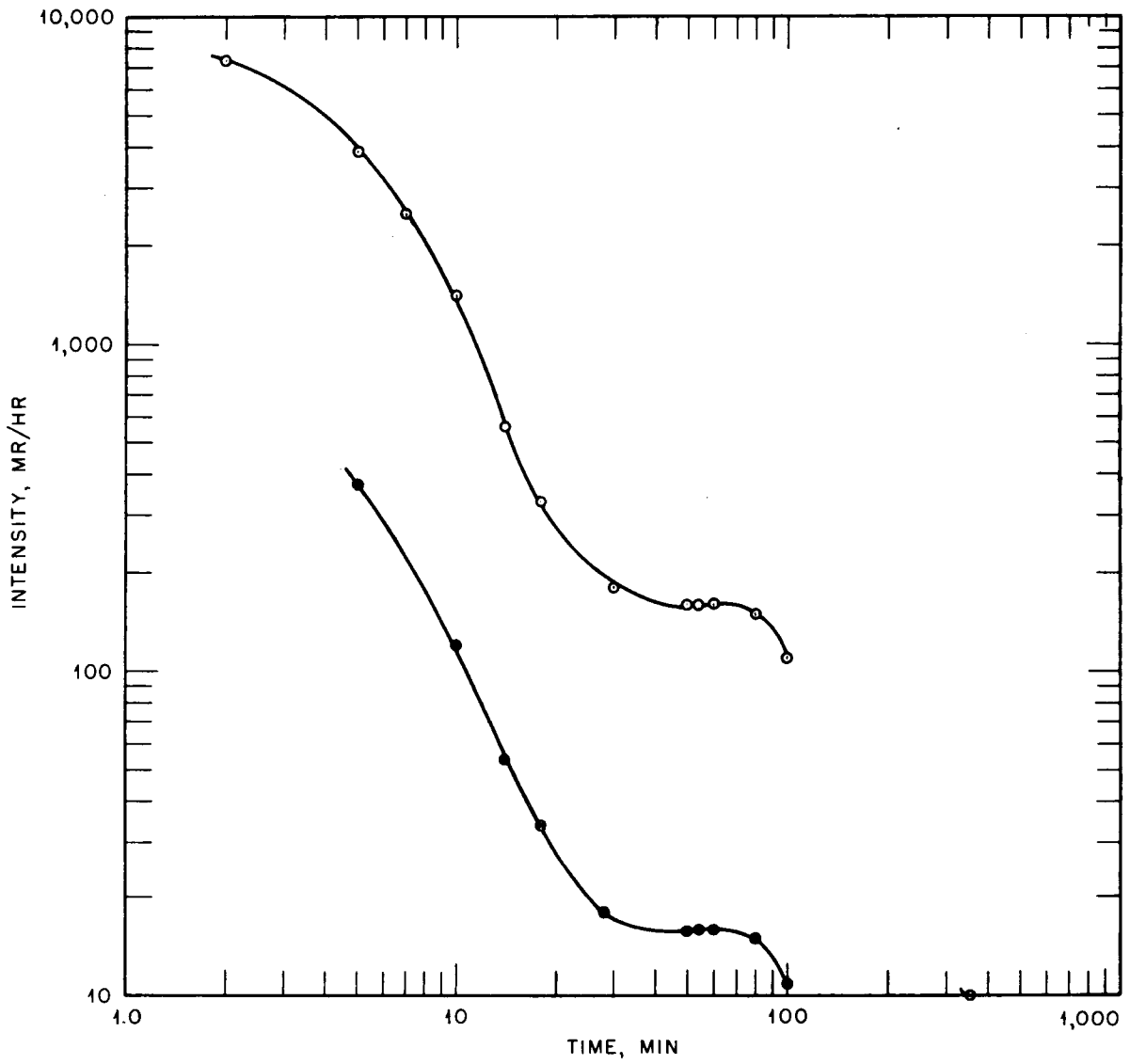

Fig. 2—Decay pattern for Project 4.1 (O, pig pen No. 6) and Project 30.2 (●, garage), shot Priscilla.

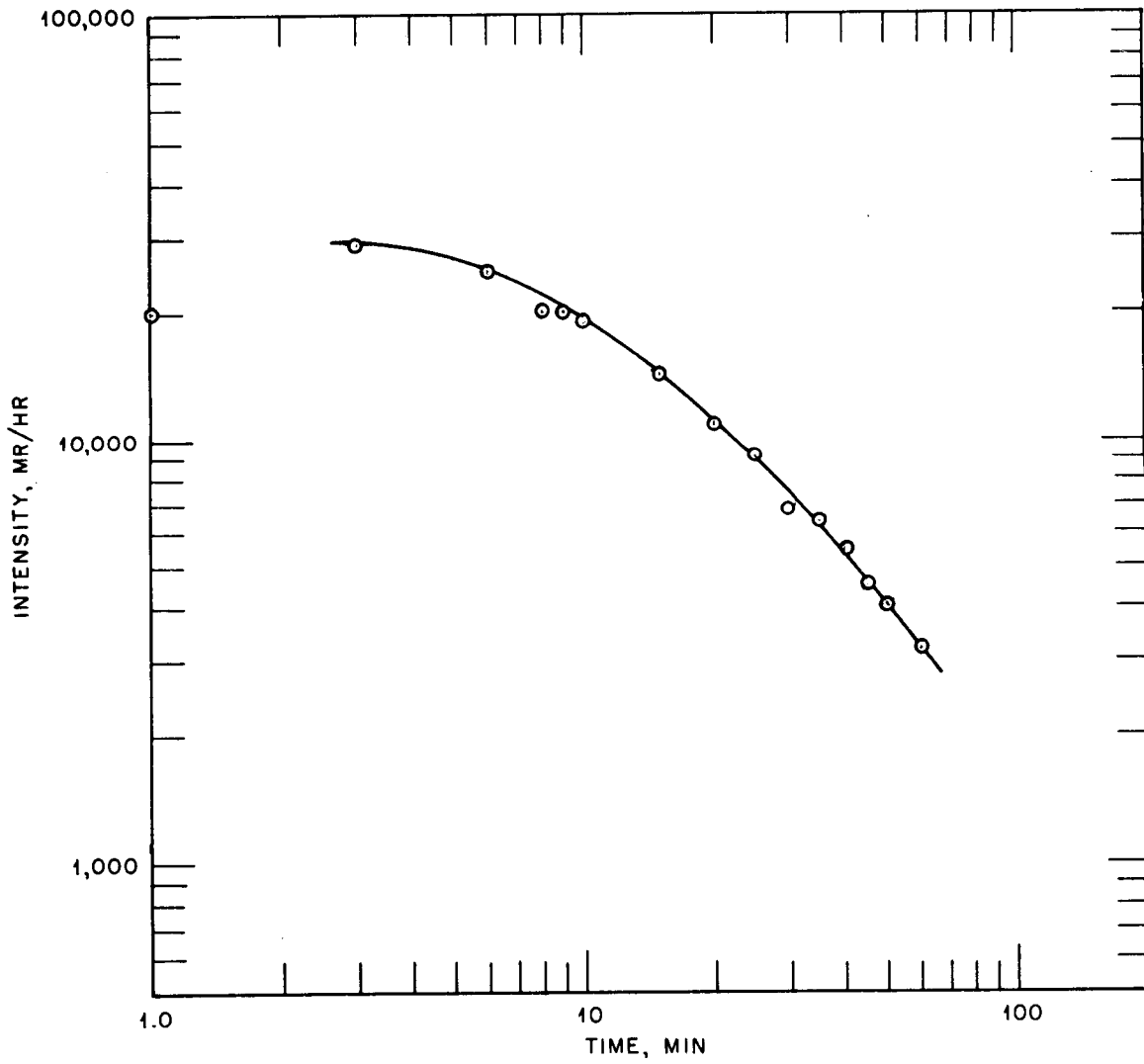

Fig. 3 — Decay pattern outside Program 33 blast shelter, shot Kepler.

1602 014

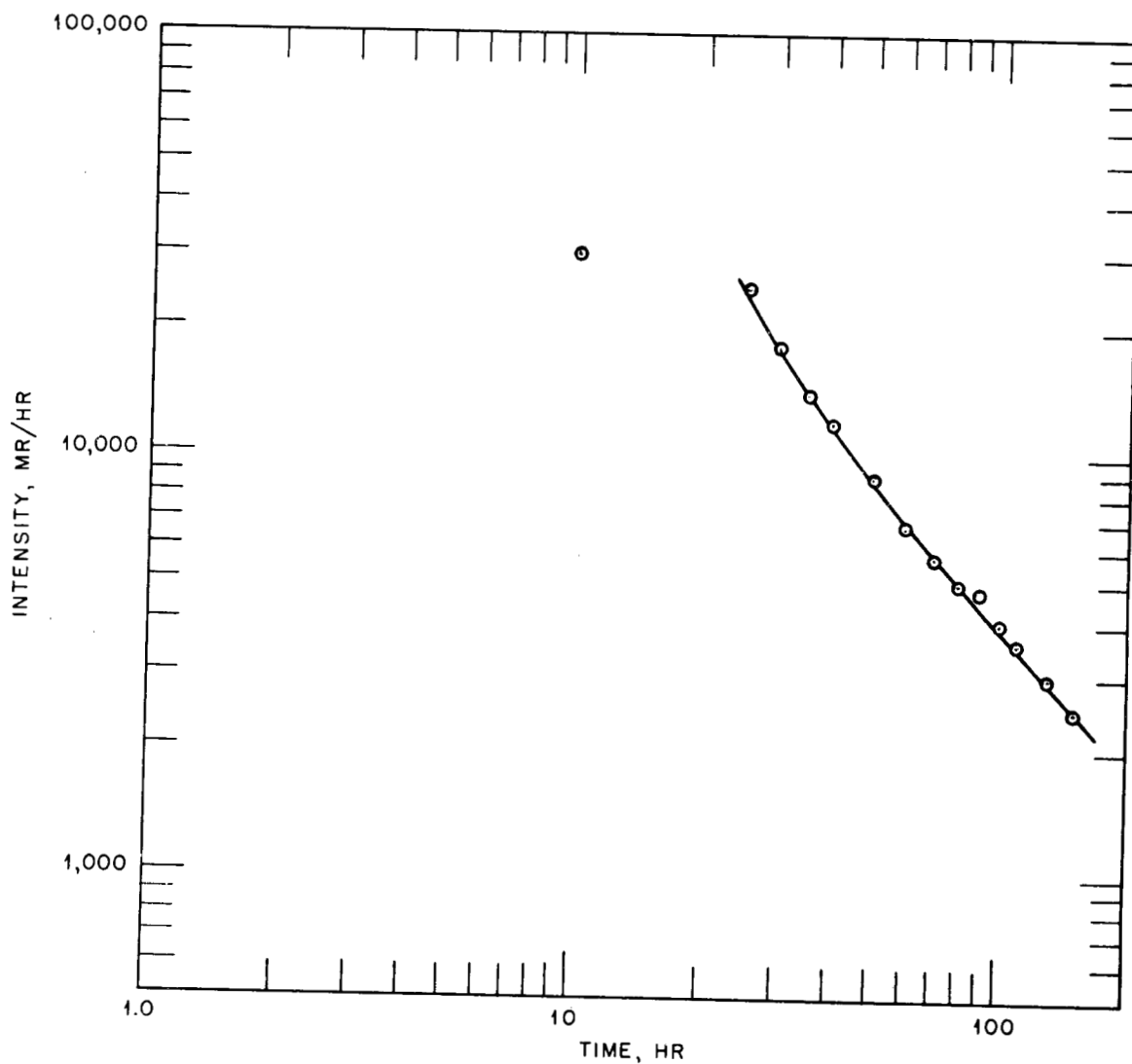

Fig. 4—Decay pattern for Project 39.5 recovery route, area T-2c, south line, 400 yd, shot Smokey.

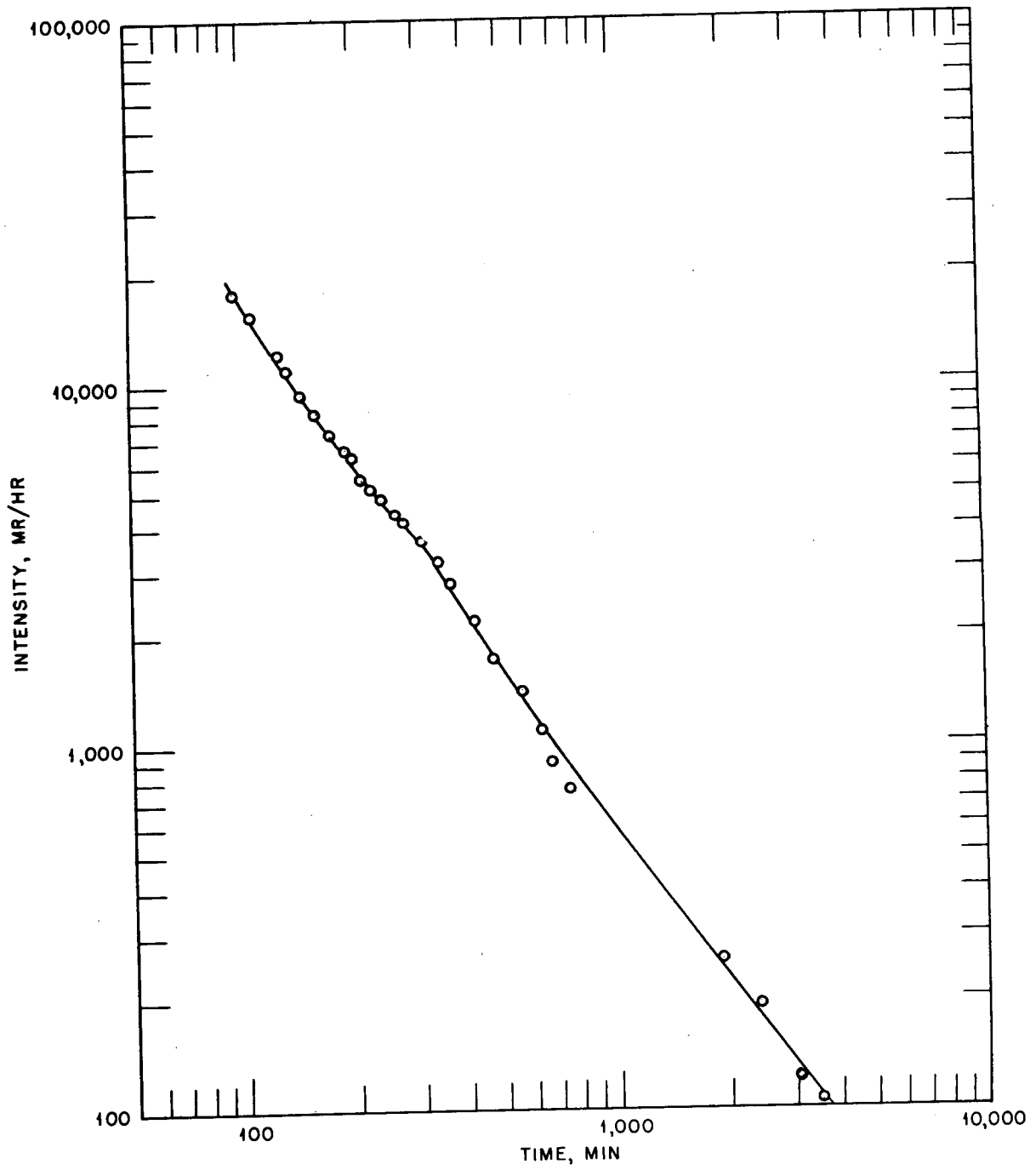

Fig. 5—Decay pattern for Butler building, center forward, shot Shasta.

402 016

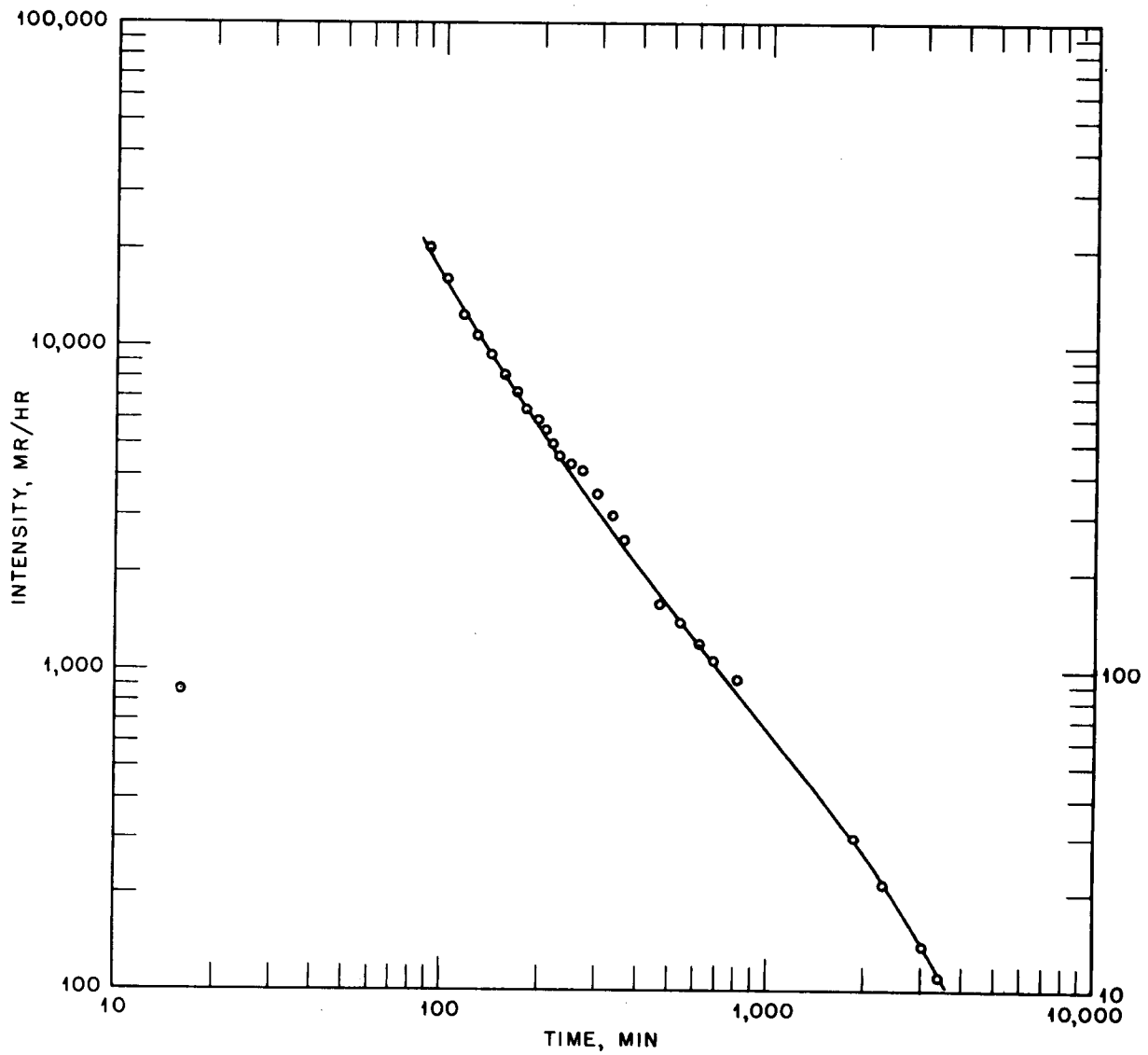

Fig. 6—Decay pattern for Butler building, right aft, shot Shasta.

402 017

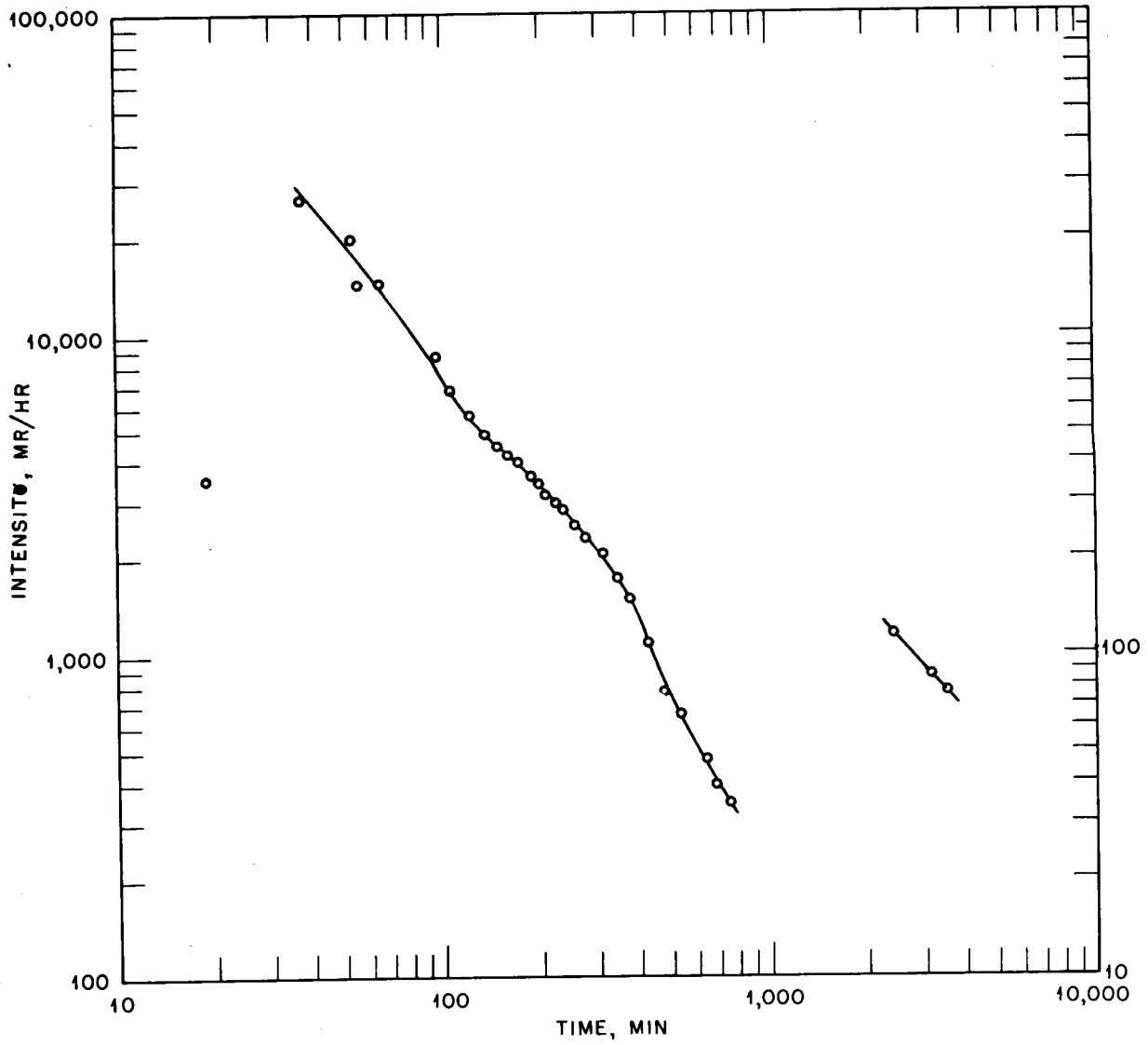

Fig. 7—Decay pattern for Butler building, left aft, shot Shasta.

402 018

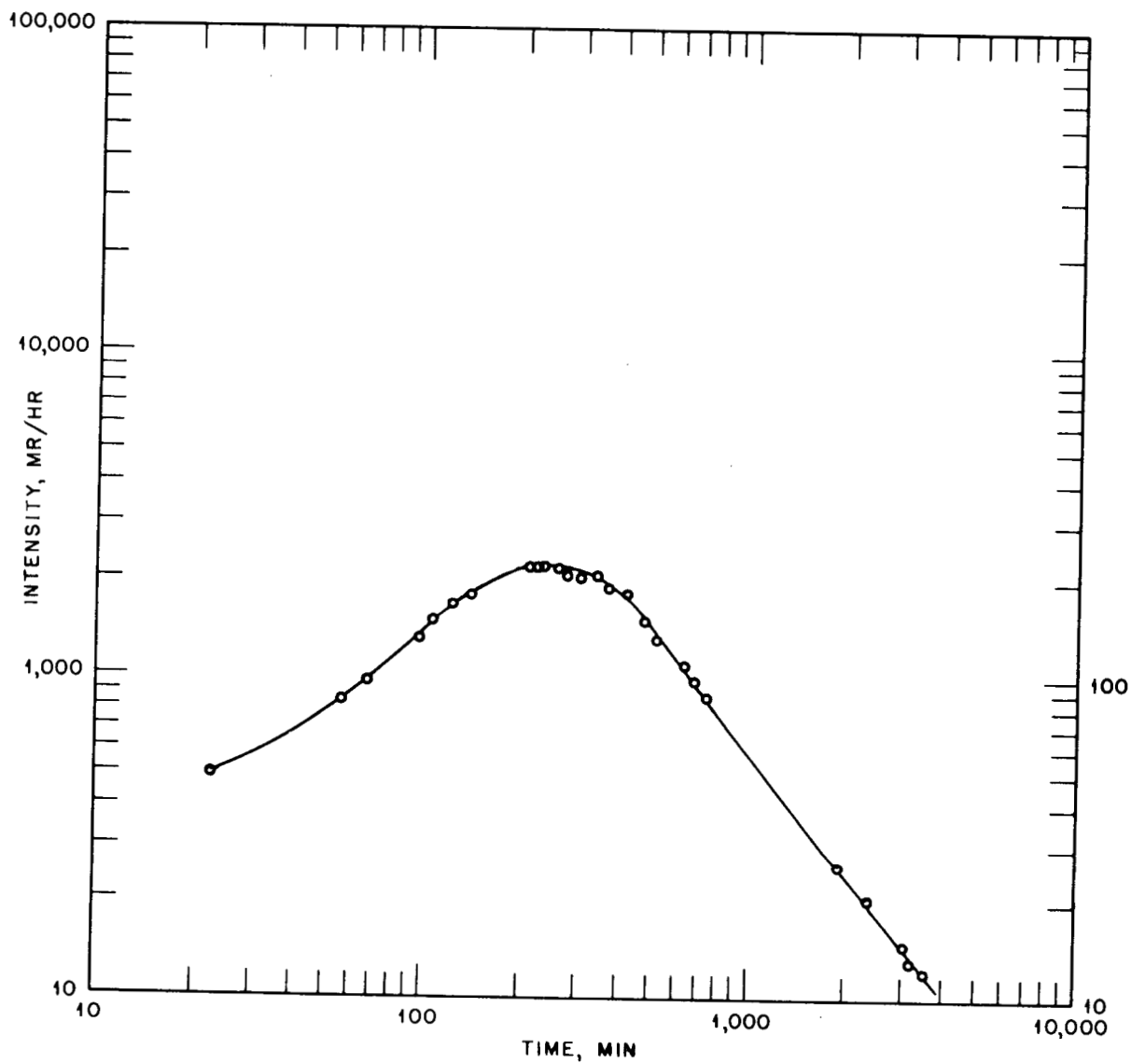

Fig. 8—Decay pattern for Butler building, inside, shot Shasta.

402 019

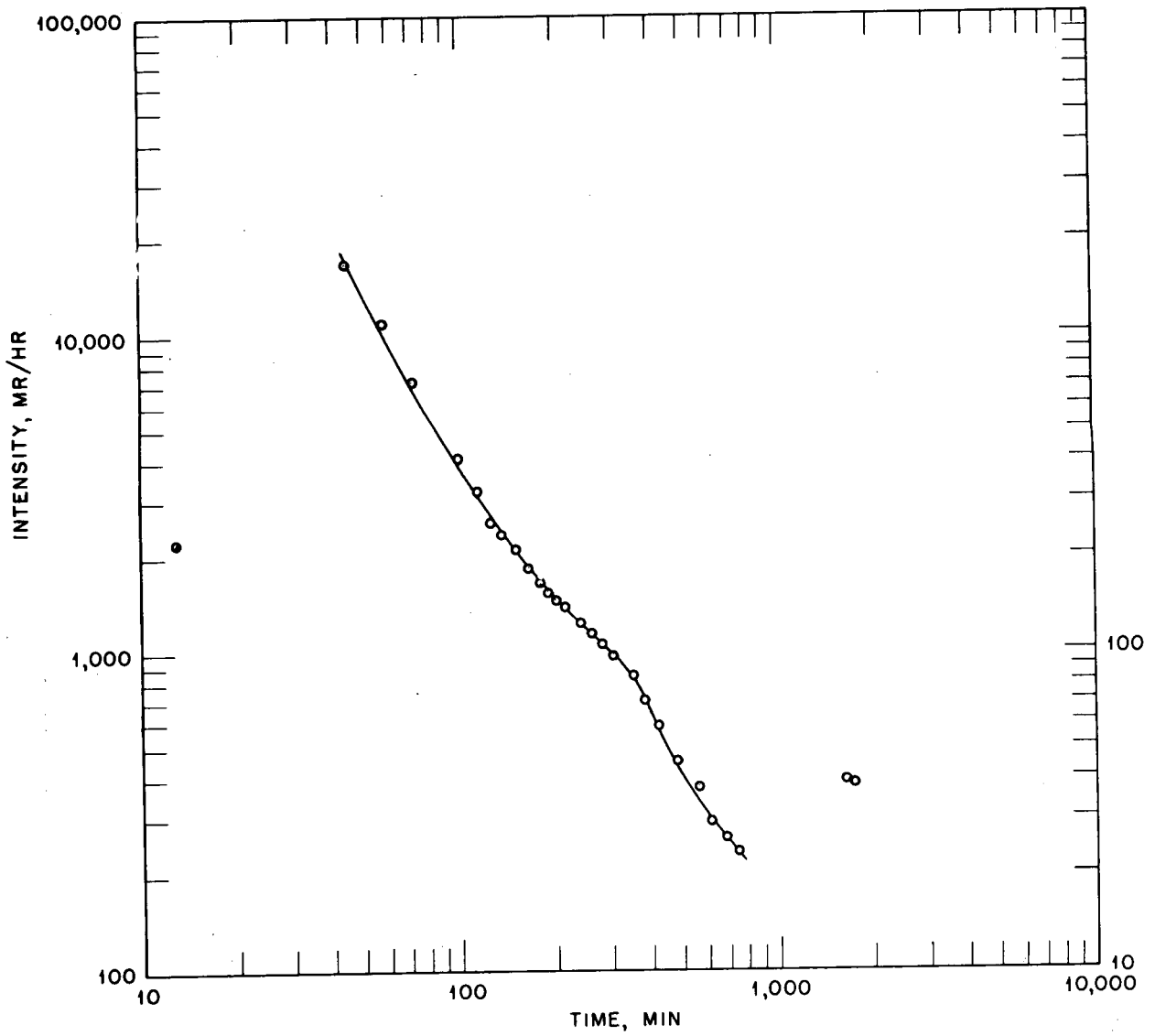

Fig. 9—Decay pattern for Project 32.3 manned shelter, right pad, shot Shasta.



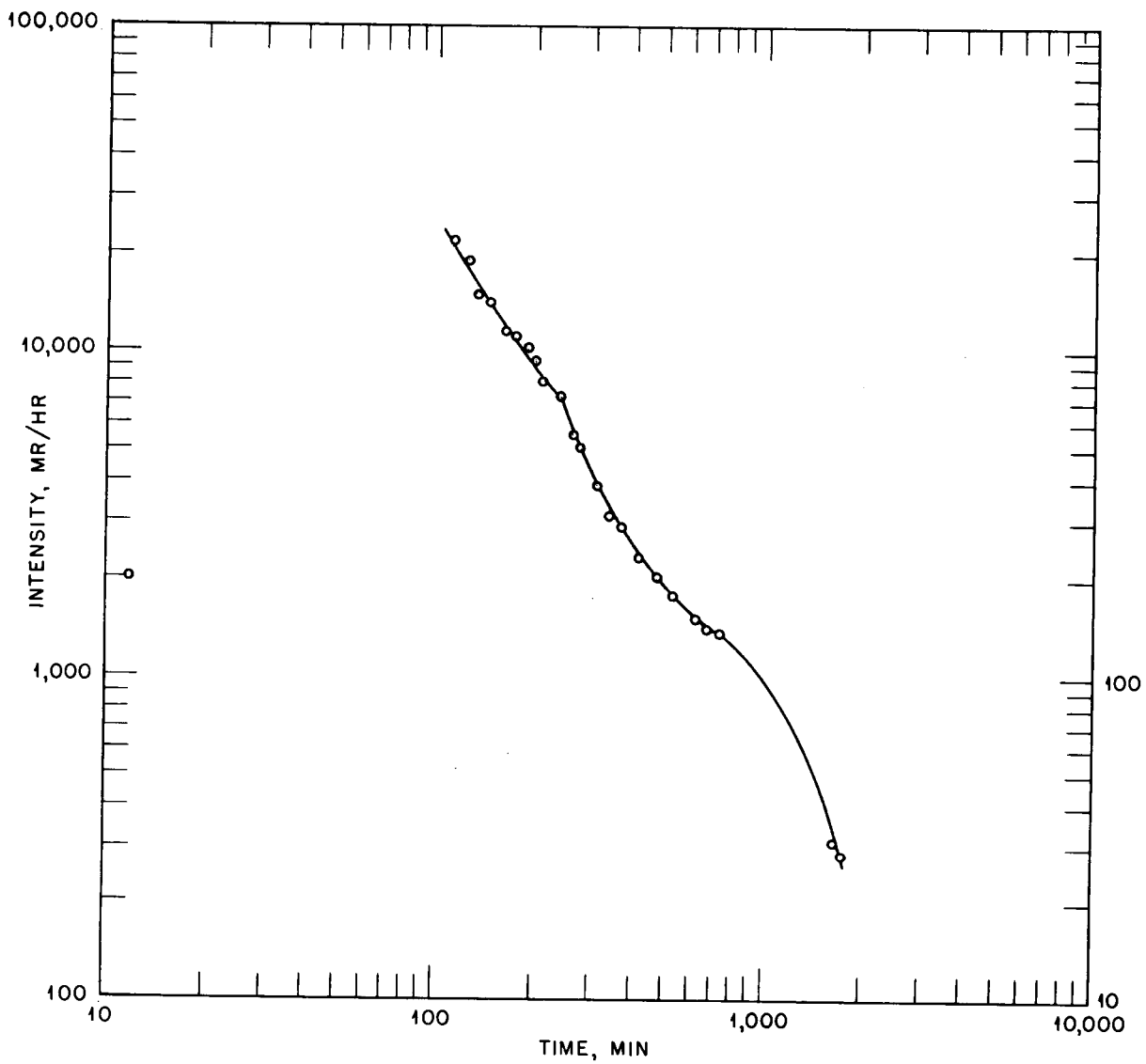

Fig. 10—Decay pattern for Project 32.3 manned shelter, left pad, shot Shasta.

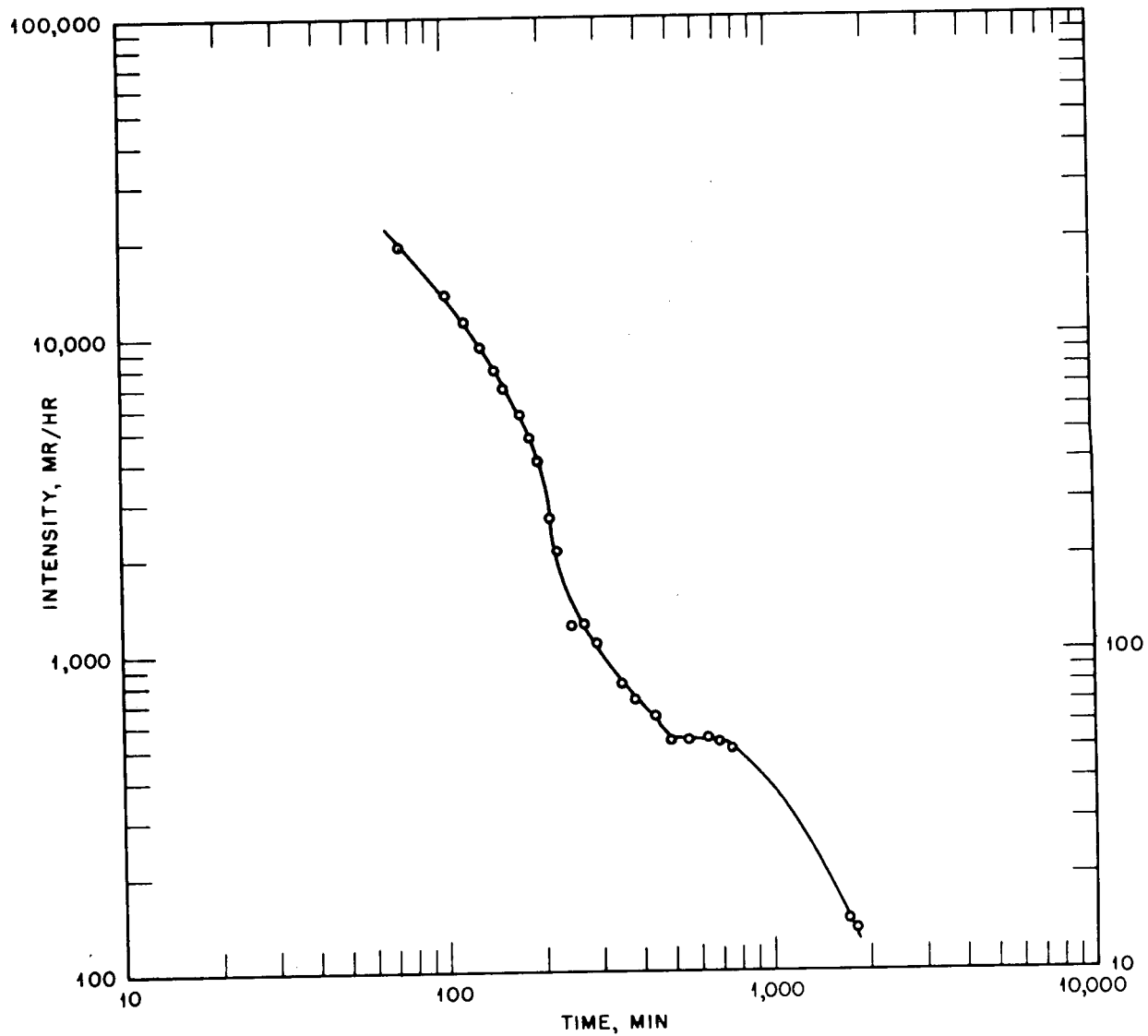

Fig. 11 — Decay pattern for Project 32.3 manned shelter, center pad, shot Shasta.

402 022 24

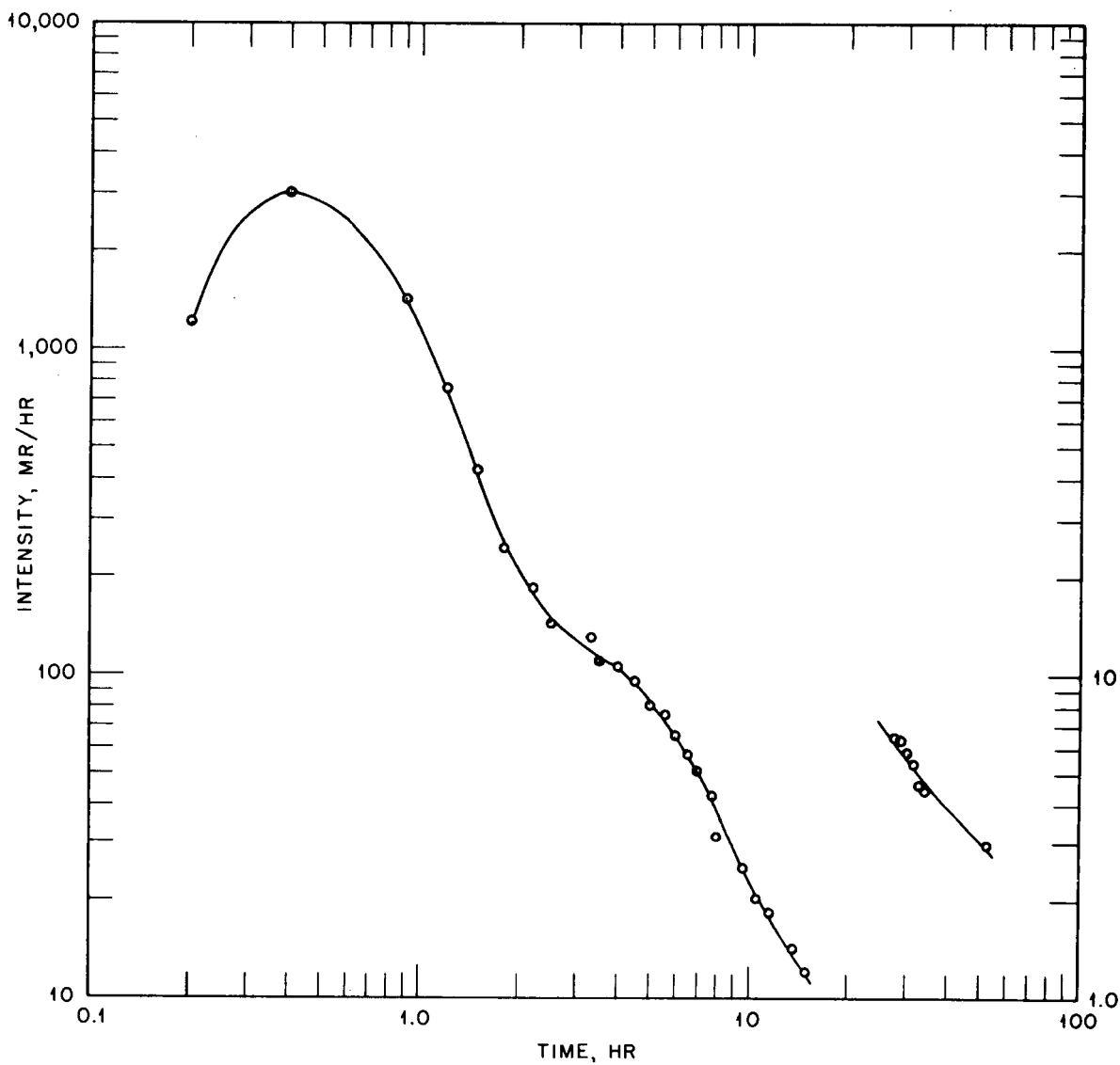

Fig. 12—Decay pattern for Butler building, center forward, shot Diablo.

402 023

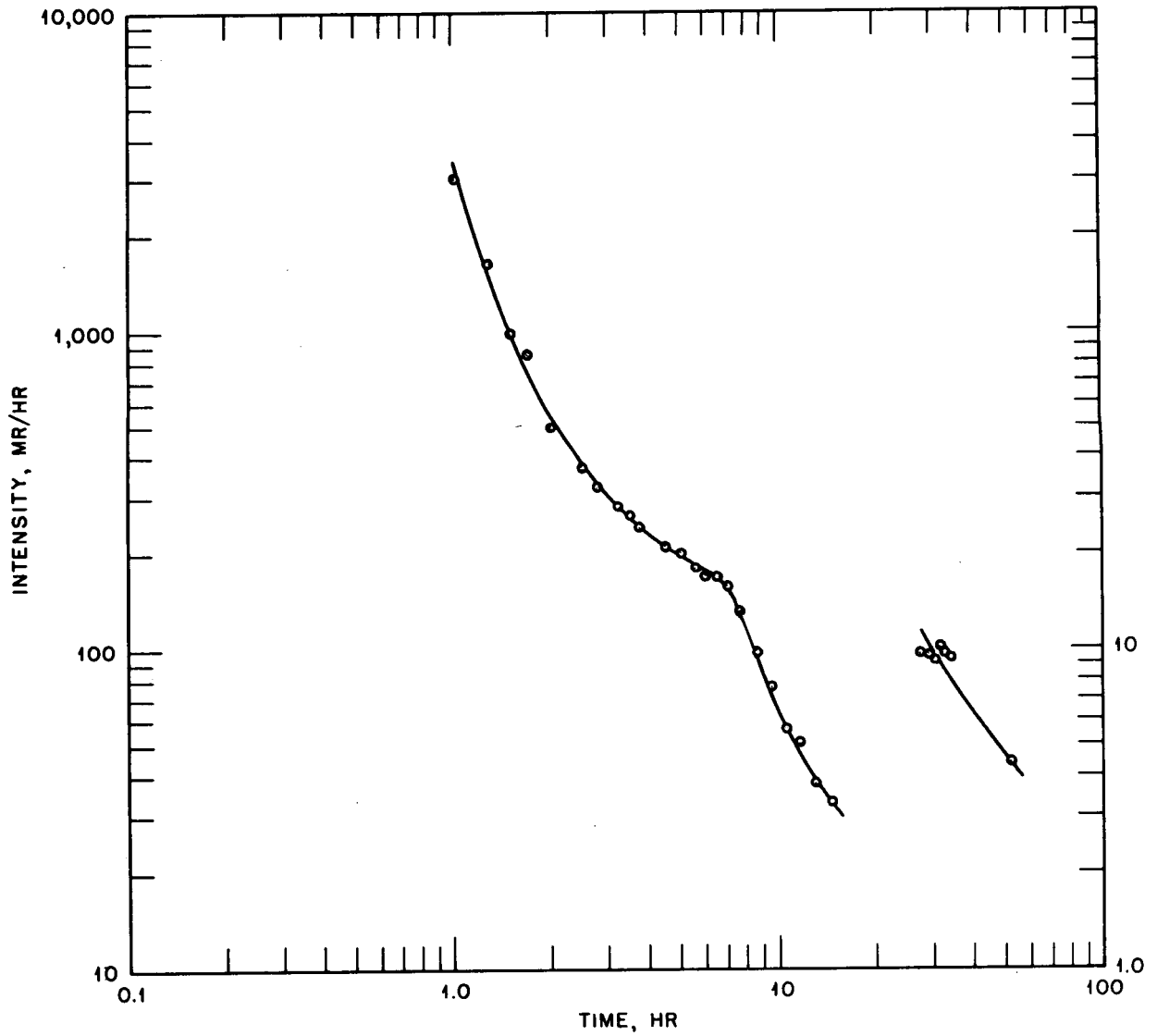

Fig. 13—Decay pattern for Butler building, right aft, shot Diablo.

402 024

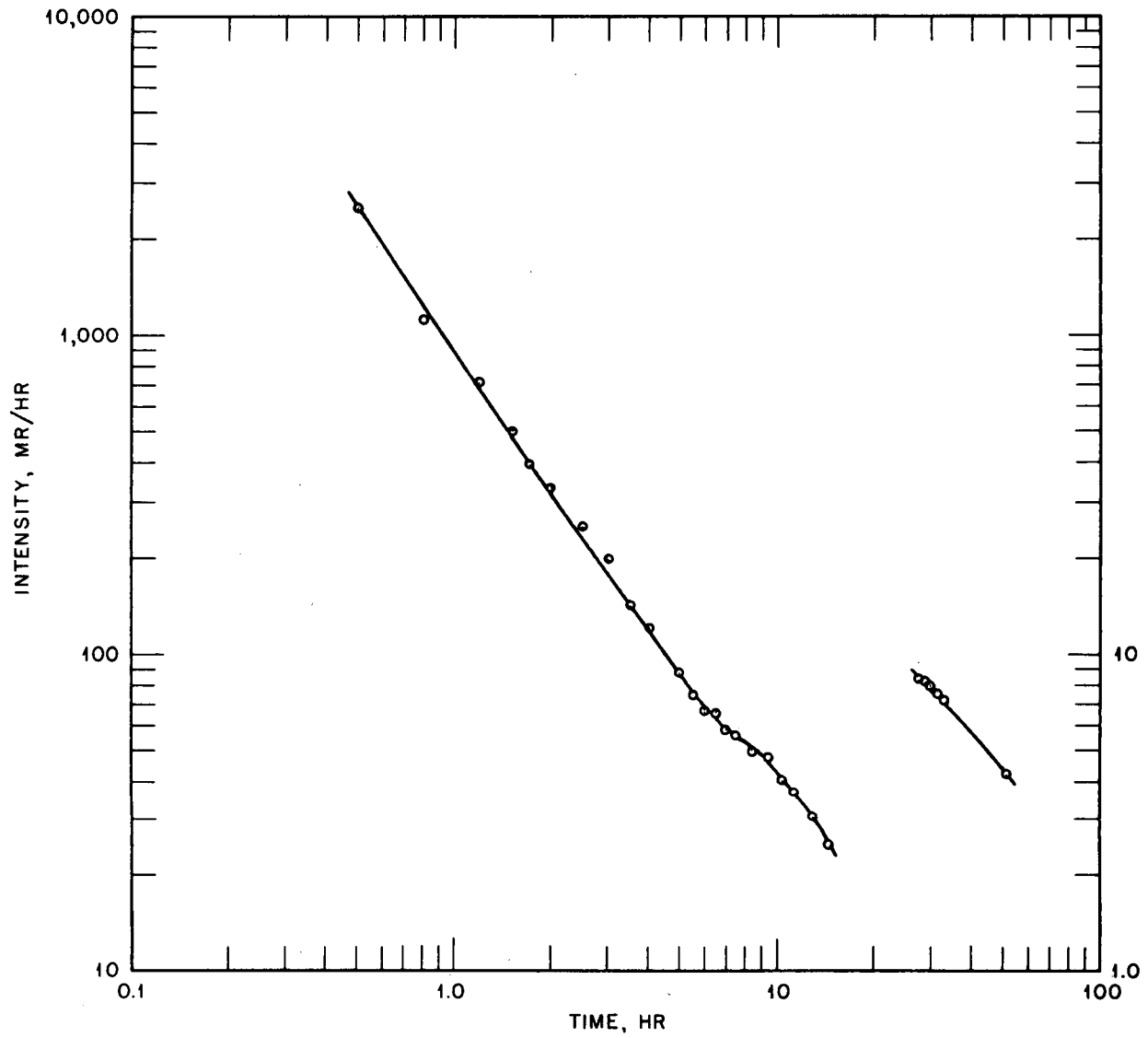

Fig. 14—Decay pattern for Butler building, left aft, shot Diablo.

402 025

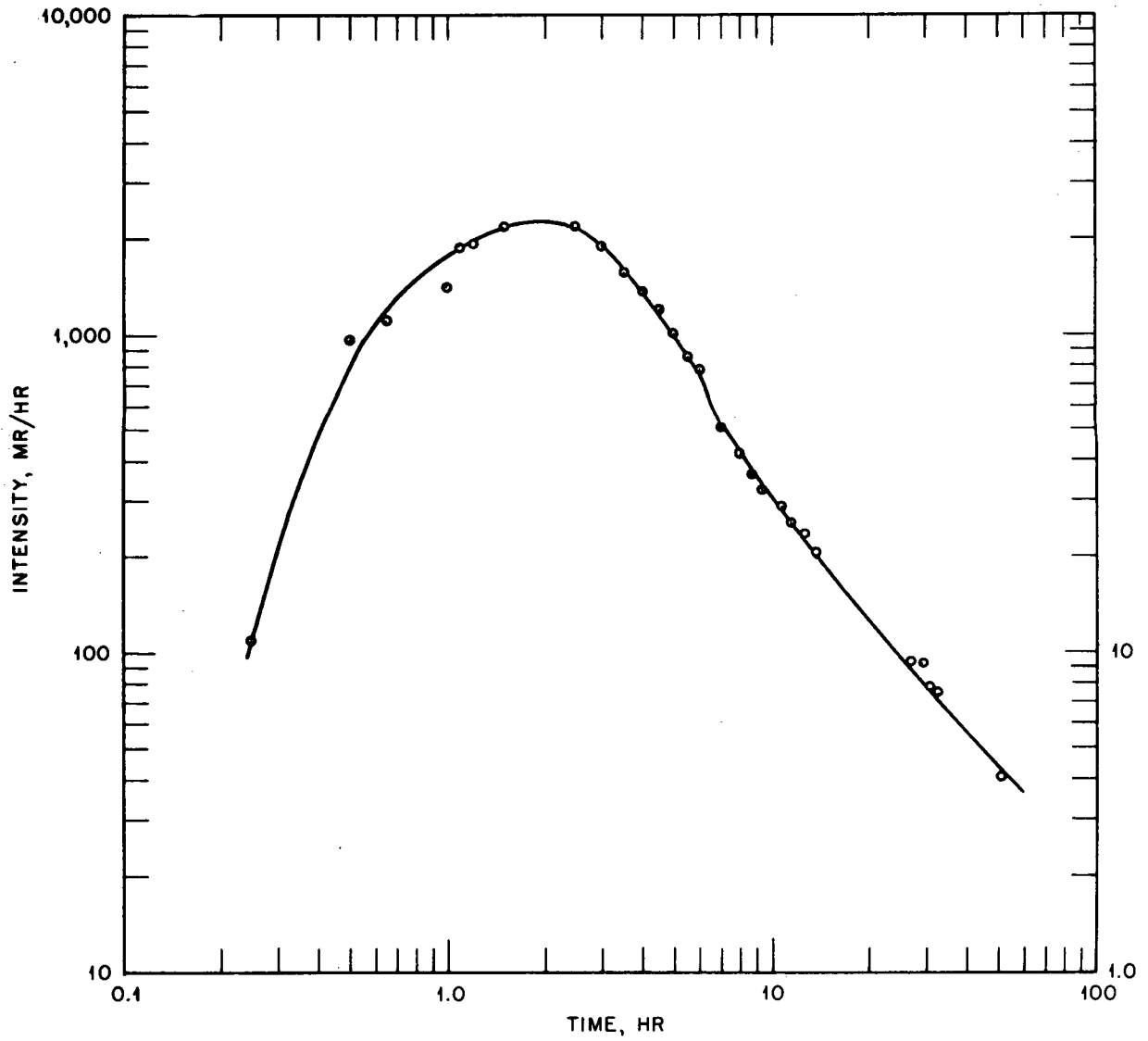

Fig. 15—Decay pattern for Butler building, inside, shot Diablo.

402 026

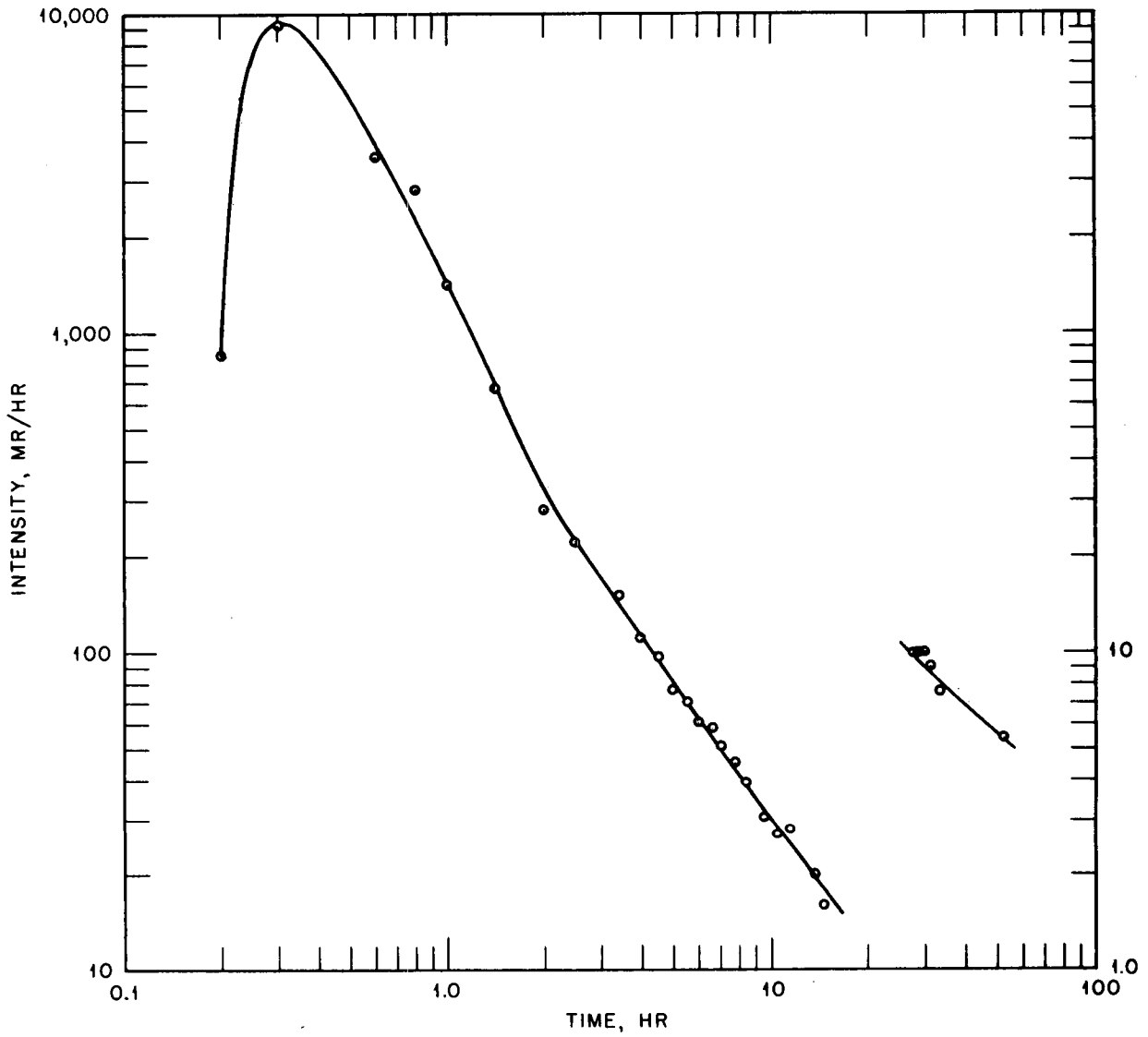

Fig. 16—Decay pattern for Project 32.3 manned shelter, right pad, shot Diablo.

402 027

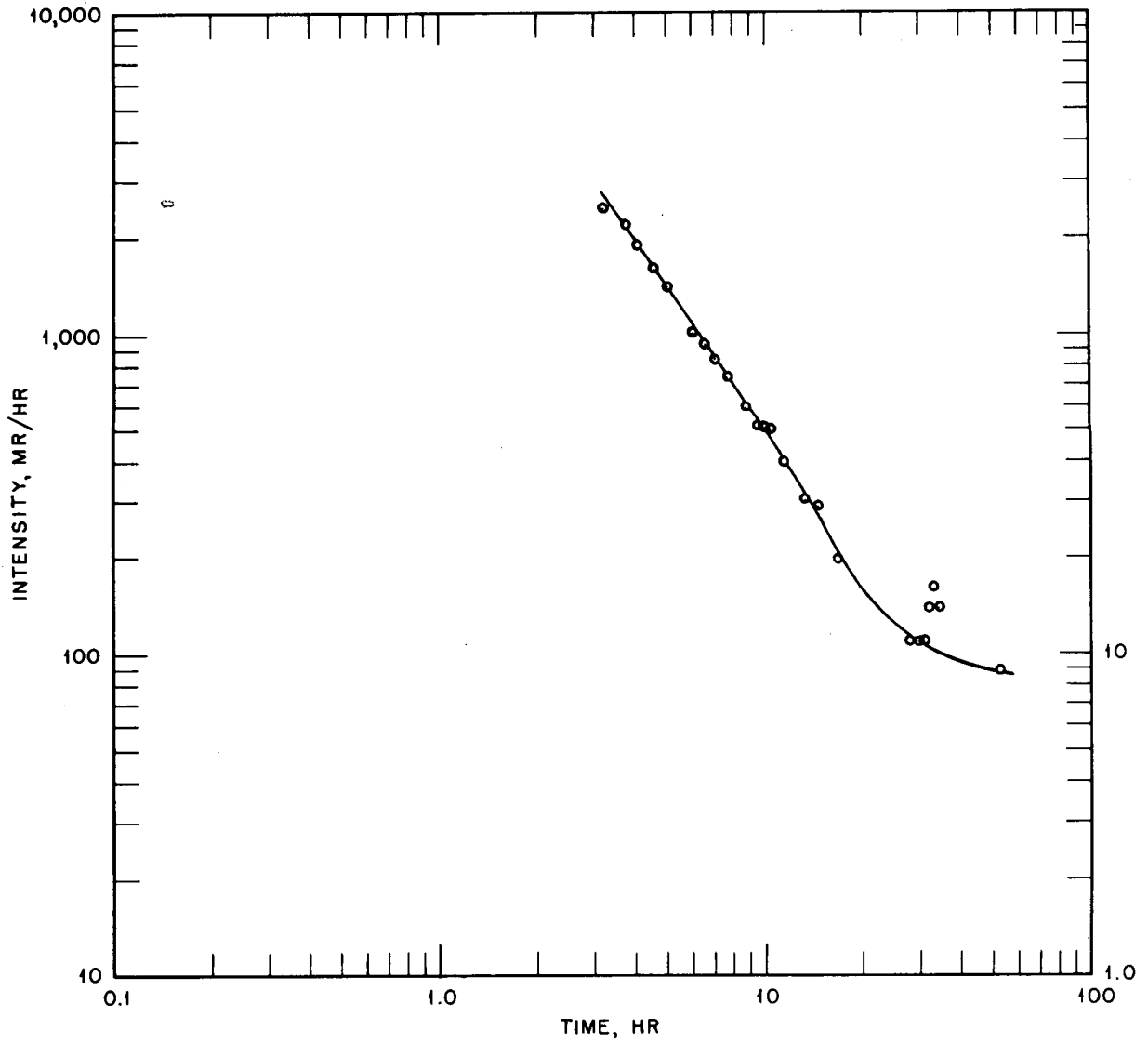

Fig. 17—Decay pattern for Project 32.3 manned shelter, left pad, shot Diablo.

402 028



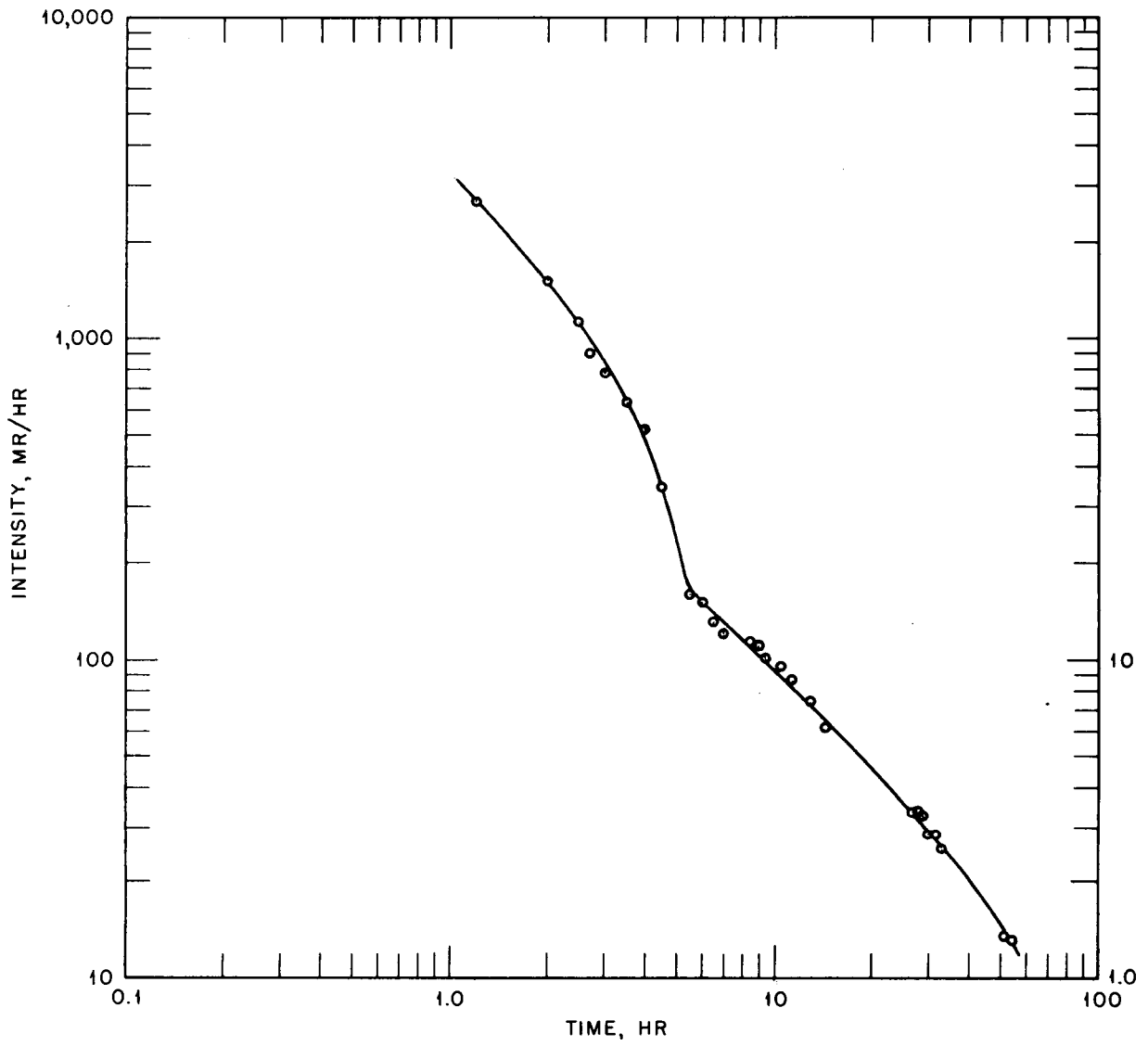

Fig. 18—Decay pattern for Project 32.3 manned shelter, center pad, shot Diablo.

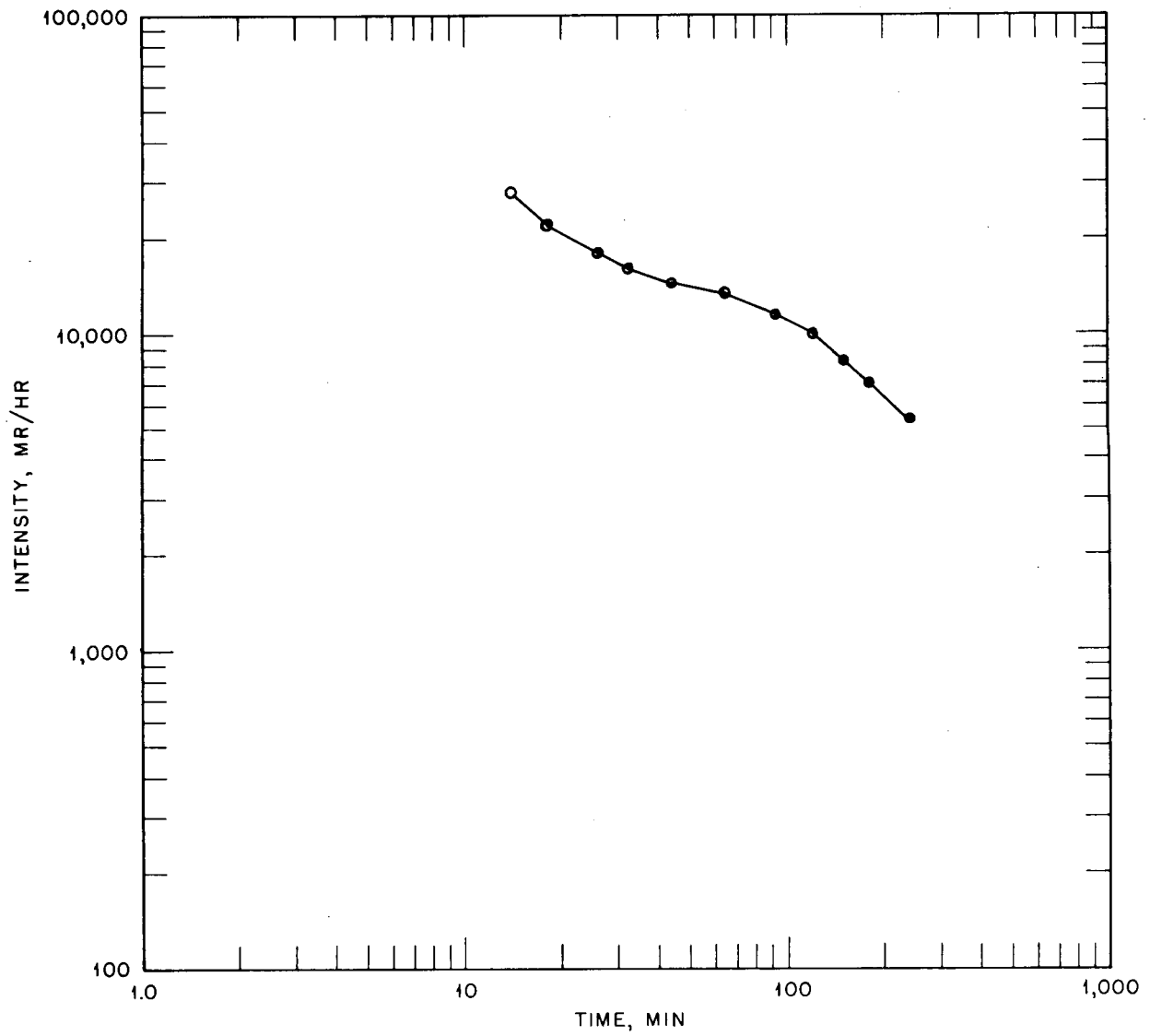

Fig. 19—Decay pattern for Projects 39.5 and 39.6 recovery route, area T-3b, 1000 yd, shot Fizeau.

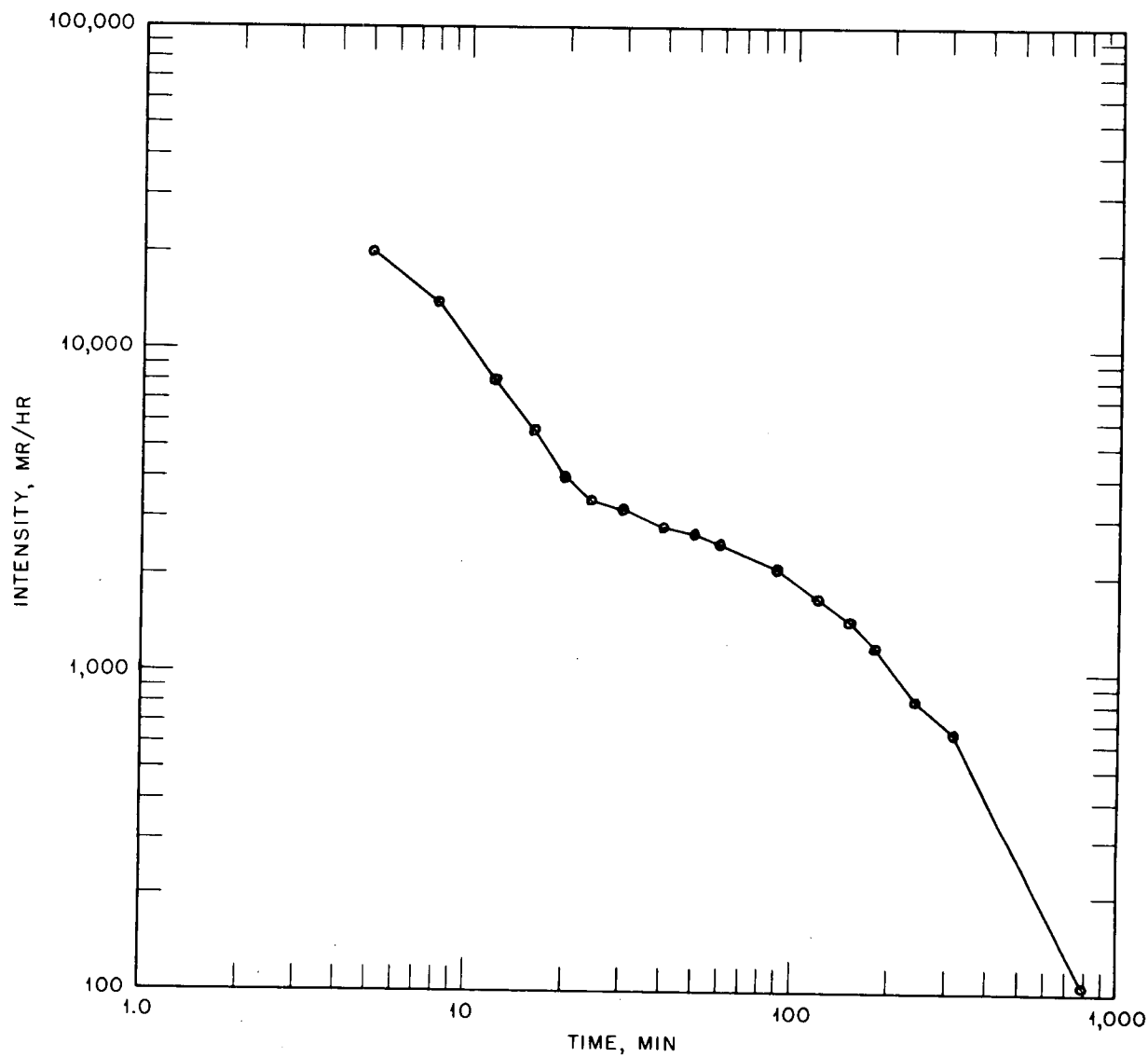

Fig. 20—Decay pattern for Projects 39.5 and 39.6 recovery route, area T-3b, 1250 yd, shot Fizeau.

402 031

TABLE 1—ON-SITE REMOTE RADIOLOGICAL MONITORING STATION LOCATIONS (COUNTERMEASURES STUDIES)

Shot	Area	Project	RDS location
Diablo	T-2b	32.3	3 units outside manned shelter, 200 yd on a bearing of 120°, 240°, 360°; shelter located in a line 10° east of north
		32.4	3 units outside and 1 inside Butler building ~10,000 ft from T-2b on a bearing 10° east of north; outside units on a bearing 120°, 240°, 360° 200 ft away from the structure
		35.1	6 units inside vault box for concrete attenuation study
Shasta	T-2a	32.3	Same as Diablo
		32.4	Same as Diablo
		35.1	Same as Diablo
Whitney	T-2	32.4	3 units outside and 1 inside each of 2 Butler buildings; outside units on a bearing 120°, 240°, 360° 200 ft away from the structure

TABLE 2—ON-SITE REMOTE RADIOLOGICAL MONITORING STATION LOCATIONS (EARLY RECOVERY STUDIES)

Shot	Area	Project	RDS location
Franklin	T-3a	39.5	N 17° 40' 40", 500 and 1000 yd
		39.6	S 120°, 720 and 875 yd from GZ
Wilson	9	39.5	S 60° E, 500, 750, 1000, 1250 yd from GZ
Priscilla	FF	39.7	W 240°, 500, 1000, 1500 yd from GZ
Hood	9	39.5	S 60° E, 750, 1000, 1250, 1500 yd from GZ
Kepler	4	33.1	Inside and outside Program 33 shelter
Stokes	7b	39.5	S 20° W, 750, 1000, 1250, 1500 yd from GZ
Doppler	7b	39.5	S 20° W, 750, 1000, 1250, 1500 yd from GZ
Galileo	1	33.1	Inside and outside Program 33 shelter
Smokey	T-2c	39.1	S 350 yd from GZ
Fizeau	T-3b	39.5	S 20° W, 500, 750, 1000, 1250
		39.6	yd from GZ
		39.6a	

TABLE 3—OFF-SITE REMOTE RADIOLOGICAL  
MONITORING STATION LOCATIONS

Station location	Distance from NTS, miles	Station location	Distance from NTS, miles
Alamo, Nev.	50	Kingman, Ariz.	160
Austin, Nev.	180	Logandale, Nev.	80
Barstow, Calif.	156	Menti, Utah	275
Beaver, Utah	195	Mt. Pleasant, Utah	290
Carson City, Nev.	245	Parowan, Utah	175
Cedar City, Utah	165	Pioche, Nev.	110
Lone Pine, Calif.	115	Provo, Utah	315
Delta, Utah	240	Reno, Nev.	260
Elko, Nev.	260	Richfield, Utah	240
Ely, Nev.	170	St. George, Utah	135
Eureka, Nev.	170	Salt Lake City, Utah	330
Eureka, Utah	280	Tonopah, Nev.	100
Hawthorne, Nev.	175	Wells, Nev.	280
Henderson, Nev.	80	Winnemucca, Nev.	280
Kanab, Utah	205	Needles, Calif.	150

402 033

TABLE 4—OFF-SITE FALLOUT DATA (SHOT BOLTZMAN)

Location	Time, hr	Reading, mr/hr*
Alamo, Nev.		
Austin, Nev.	H + 8	3.5
	H + 10	3.0
Barstow, Calif.		
Beaver, Utah		
Carson City, Nev.		
Cedar City, Utah		
Lone Pine, Calif.		
Delta, Utah		
Elko, Nev.		
Ely, Nev.		
Eureka, Nev.		
Eureka, Utah		
Hawthorne, Nev.		
Henderson, Nev.		
Kanab, Utah		
Kingman, Ariz.		
Logandale, Nev.	H + 2 $\frac{1}{3}$	0.30
Manti, Utah		
Mt. Pleasant, Utah		
Parowan, Utah		
Pioche, Nev.		
Provo, Utah		
Reno, Nev.		
Richfield, Utah		
St. George, Utah		
Salt Lake City, Utah		
Tonopah, Nev.	H + 4	1.0
	H + 10	0.45
Wells, Nev.		
Winnemucca, Nev.		
Needles, Calif.		

\*Where no readings are given, the intensities were less than 0.3 mr/hr.

TABLE 5—OFF-SITE FALLOUT DATA (SHOT PRISCILLA)

Location	Time, hr	Reading, mr/hr*
Alamo, Nev.		
Austin, Nev.		
Barstow, Calif.		
Beaver, Utah		
Carson City, Nev.		
Cedar City, Utah	H + 13	1.0
Lone Pine, Calif.		
Delta, Utah		
Elko, Nev.		
Ely, Nev.		
Eureka, Nev.		
Eureka, Utah		
Hawthorne, Nev.		
Henderson, Nev.		
Kanab, Utah		
Kingman, Ariz.		
Logandale, Nev.		
Manti, Utah		
Mt. Pleasant, Utah		
Parowan, Utah	H + 13	1.0
Ploche, Nev.		
Provo, Utah		
Reno, Nev.		
Richfield, Utah		
St. George, Utah		
Salt Lake City, Utah		
Tonopah, Nev.		
Wells, Nev.		
Winnemucca, Nev.		
Needles, Calif.		

\*Where no readings are given, the intensities were less than 0.3 mr/hr.

402 035

TABLE 6—OFF-SITE FALLOUT DATA (SHOT KEPLER)

Location	Time, hr	Reading, mr/hr*
Alamo, Nev.		
	H + 14	0.32
Austin, Nev.	H + 4 <sup>1</sup> / <sub>3</sub>	0.5
	H + 10	0.3
Barstow, Calif.		
Beaver, Utah		
Carson City, Nev.	H + 10	0.5
Cedar City, Utah		
Lone Pine, Calif.		
Delta, Utah		
Elko, Nev.		
Ely, Nev.		
Eureka, Nev.	H + 10	1.0
	H + 14	0.6
Eureka, Utah		
Hawthorne, Nev.		
Henderson, Nev.		
Kanab, Utah		
Kingman, Ariz.		
Logandale, Nev.		
Manti, Utah		
Mt. Pleasant, Utah		
Parowan, Utah		
Pioche, Nev.		
Provo, Utah		
Reno, Nev.		
Richfield, Utah		
St. George, Utah		
Salt Lake City, Utah		
Tonopah, Nev.	H + 10	0.30
Wells, Nev.		
Winnemucca, Nev.		
Needles, Calif.		

\*Where no readings are given, the intensities were less than 0.3 mr/hr.

402 036



TABLE 7—OFF-SITE FALLOUT DATA (SHOT SMOKEY)

Location	Time, hr	Reading, mr/hr*
Alamo, Nev.		
Austin, Nev.		
Barstow, Calif.		
Beaver, Utah		
Carson City, Nev.		
Cedar City, Utah	H + 8	1.0
	H + 8 <sup>1</sup> / <sub>2</sub>	0.9
	H + 9 <sup>1</sup> / <sub>4</sub>	1.1
	H + 10	1.7
	H + 12	2.5
	H + 15	1.5
	H + 36	1.0
	H + 40	0.6
	H + 46	Trace
Lone Pine, Calif.		
Delta, Utah		
Elko, Nev.		
Ely, Nev.		
Eureka, Nev.		
Eureka, Utah		
Hawthorne, Nev.		
Henderson, Nev.		
Kanab, Utah		
Kingman, Ariz.		
Logandale, Nev.	H + 8	1.0
	H + 8 <sup>1</sup> / <sub>2</sub>	0.6
	H + 9 <sup>1</sup> / <sub>4</sub>	0.4
	H + 10	0.3
Manti, Utah		
Mt. Pleasant, Utah		
Parowan, Utah		
Pioche, Nev.		
Provo, Utah		
Reno, Nev.		
Richfield, Utah		
St. George, Utah	H + 8	10
	H + 8 <sup>1</sup> / <sub>2</sub>	14
	H + 9 <sup>1</sup> / <sub>4</sub>	14
	H + 10	13
	H + 12	11.5
	H + 15	9
	H + 36	4
	H + 40	3.6
	H + 46	2.9
	H + 52	1.8
Salt Lake City, Utah		
Tonopah, Nev.		
Wells, Nev.		
Winnemucca, Nev.		
Needles, Calif.		

\*Where no readings are given, the intensities were less than 0.3 mr/hr.

TABLE 8—OFF-SITE FALLOUT DATA (SHOT SHASTA)

Location	Time, hr	Reading, mr/hr*
Alamo, Nev.		
Austin, Nev.		
Barstow, Calif.		
Beaver, Utah		
Carson City, Nev.		
Cedar City, Utah		
Lone Pine, Calif.		
Delta, Utah		
Elko, Nev.	H + 10	0.85
	H + 12	0.60
	H + 16	0.12
Ely, Nev.	H + 12	0.4
	H + 16	0.60
	H + 23	1.1
	H + 27	1.1
Eureka, Nev.	H + 7	2.0
	H + 10	4.9
	H + 11	11.5
	H + 12	9.2
	H + 16	6.5
	H + 23	4.9
	H + 27	4.2
Eureka, Utah		
Hawthorne, Nev.		
Henderson, Nev.		
Kanab, Utah		
Kingman, Ariz.		
Logandale, Nev.		
Manti, Utah		
Mt. Pleasant, Utah		
Parowan, Utah		
Pioche, Nev.		
Provo, Utah		
Reno, Nev.		
Richfield, Utah		
St. George, Utah		
Salt Lake City, Utah		
Tonopah, Nev.		
Wells, Nev.		
Winnemucca, Nev.	H + 10	0.3
Needles, Calif.		

\*Where no readings are given, the intensities were less than 0.3 mr/hr.

038

TABLE 9—OFF-SITE FALLOUT DATA (SHOT FIZEAU)

Location	Time, hr	Reading, mr/hr*
Alamo, Nev.		
Austin, Nev.		
Barstow, Calif.		
Beaver, Utah		
Carson City, Nev.	H + 8	0.7
	H + 15	0.7
	H + 20	0.7
	H + 25	0.7
Cedar City, Utah		
Lone Pine, Calif.		
Delta, Utah		
Elko, Nev.		
Ely, Nev.		
Eureka, Nev.		
Eureka, Utah		
Hawthorne, Nev.	Inoperative after second call	
Henderson, Nev.		
Kanab, Utah		
Kingman, Ariz.		
Logandale, Nev.		
Manti, Utah		
Mt. Pleasant, Utah		
Parowan, Utah		
Pioche, Nev.		
Provo, Utah		
Reno, Nev.	Inoperative	
Richfield, Utah		
St. George, Utah		
Salt Lake City, Utah		
Tonopah, Nev.	H + 6	10
	H + 6 <sup>1</sup> / <sub>2</sub>	10
	H + 8	8
	H + 15	3.8
	H + 20	2.5
	H + 25	2.2
Wells, Nev.		
Winnemucca, Nev.		
Needles, Calif.		

\*Where no readings are given, the intensities were less than 0.3 mr/hr.

TABLE 10—OFF-SITE FALLOUT DATA (SHOT NEWTON)

Location	Reading, mr/hr
All off-site stations challenged	All intensities were less than 0.3 mr/hr

TABLE 11—OFF-SITE FALLOUT DATA (SHOT WHITNEY)

Location	Time, hr	Reading, mr/hr*
Alamo, Nev.		
Austin, Nev.	H + 21	0.5
Barstow, Calif.		
Beaver, Utah		
Carson City, Nev.		
Cedar City, Utah		
Lone Pine, Calif.		
Delta, Utah		
Elko, Nev.		
Ely, Nev.		
Eureka, Nev.		
Eureka, Utah		
Hawthorne, Nev.		
Henderson, Nev.		
Kanab, Utah		
Kingman, Ariz.		
Logandale, Nev.		
Manti, Utah		
Mt. Pleasant, Utah		
Parowan, Utah		
Pioche, Nev.		
Provo, Utah		
Reno, Nev.		
Richfield, Utah		
St. George, Utah		
Salt Lake City, Utah		
Tonopah, Nev.	H + 8	5.4
	H + 9 <sup>1</sup> / <sub>2</sub>	13
	H + 10 <sup>1</sup> / <sub>2</sub>	13
	H + 13 <sup>1</sup> / <sub>2</sub>	10
	H + 16	8.2
	H + 18	7
	H + 21	6.2
	H + 25	5
	H + 27	4.2
Wells, Nev.		
Winnemucca, Nev.		
Needles, Calif.		

\*Where no readings are given, the intensities were less than 0.3 mr/hr.

TABLE 12—OFF-SITE FALLOUT DATA (SHOT CHARLESTON)

Location	Reading, mr/hr
All off-site stations challenged	All intensities were less than 0.3 mr/hr

TABLE 13—ON-SITE MONITORING (SHOT WHITNEY)

Location	Time, min	Reading, mr/hr
New Butler Building		
Right forward (200 ft)	H + 9	17
	H + 30	17
	H + 65	16
	H + 110	15
	H + 148	15
	H + 222	14
	H + 304	14
Center aft (200 ft)	H + 11	12.5
	H + 32	12.5
	H + 68	12
	H + 112	12
	H + 150	12
	H + 224	12
	H + 306	12
Inside building	H + 13	4.6
	H + 34	4.4
	H + 70	4.4
	H + 114	4.6
	H + 152	4.6
	H + 226	4.5
Left forward (200 ft)	H + 308	4.5
	H + 16	15
	H + 36	15
	H + 72	17
	H + 115	17
	H + 153	16
	H + 228	16
	H + 310	15

402 041

TABLE 13—ON-SITE MONITORING (SHOT WHITNEY) (Continued)

Location	Time, min	Reading, mr/hr
Old Butler Building		
Right aft (200 ft)	H + 20	10
	H + 50	10
	H + 135	10
	H + 210	10
	H + 295	11
Left aft (200 ft)	H + 22	10
	H + 52	10
	H + 138	12
	H + 214	10
Center forward (200 ft)	H + 296	10
	H + 24	10.5
	H + 55	10.5
	H + 145	10.5
Inside building	H + 215	10.5
	H + 298	10.5
	H + 26	0.4
	H + 57	0.4
	H + 125	0.4
Left pad	H + 150	0.4
	H + 217	0.4
	H + 300	0.4
	H + 5	24
	H + 26	24
	H + 42	24
	H + 75	24
	H + 105	24
	H + 142	22
	H + 219	22
Right pad	H + 301	22
	H + 7	11
	H + 29	11
	H + 46	11
	H + 80	11
	H + 108	13
	H + 155	12
	H + 220	12
	H + 302	12

TABLE 14—COMPARATIVE RADIATION INTENSITY READINGS (SHOT DIABLO)

Time, hr	RDS, mr/hr	Juno, mr/hr	T-1b, mr/hr
H + 29	9.4	6	8
	81	77	80
	96	115	110
H + 54	4.2	5.5	5
	44	40	33
	44	45	40
H + 100	19	17	18
	21.5	22.5	22
	11	20.5	20
H + 128	18	17	17
	16	11.5	15
	1.0	0.8	1.2

TABLE 15—COMPARATIVE RADIATION INTENSITY READINGS (SHOT SHASTA)

Time, hr	RDS, mr/hr	Juno, mr/hr	T-1b, mr/hr
H + 12	480		540
	250		275
	535		580
H + 27	140		150
	230		280
	1400		1800
H + 32	80	68	90
	65	50	70
	40	45	57

402 043



4  
3

2

1





**Appendix A**

**REMOTE RADIATION-MONITORING SYSTEM**

**NATIONAL BUREAU OF STANDARDS REPORT**

**By**

**L. Costrell  
Radiation Physics Laboratory**

**To**

**Radiation Instruments Branch  
Division of Biology and Medicine  
U. S. Atomic Energy Commission  
Washington, D. C.**

The material presented in this appendix has been taken directly from Report NBS-5471. The format has been changed slightly for its presentation as an appendix to this report.

402 044



## FOREWORD

This report describes a radiation-monitoring system designed for the monitoring of radioactive fallout. The system was developed for the Radiation Instruments Branch of the Division of Biology and Medicine of the Atomic Energy Commission and has been used for the remote monitoring of gamma radiation during atomic bomb tests in Nevada.

LOUIS COSTRELL, Chief  
Nucleonic Instrumentation Section

H. O. WYCKOFF, Chief  
Radiation Physics Laboratory

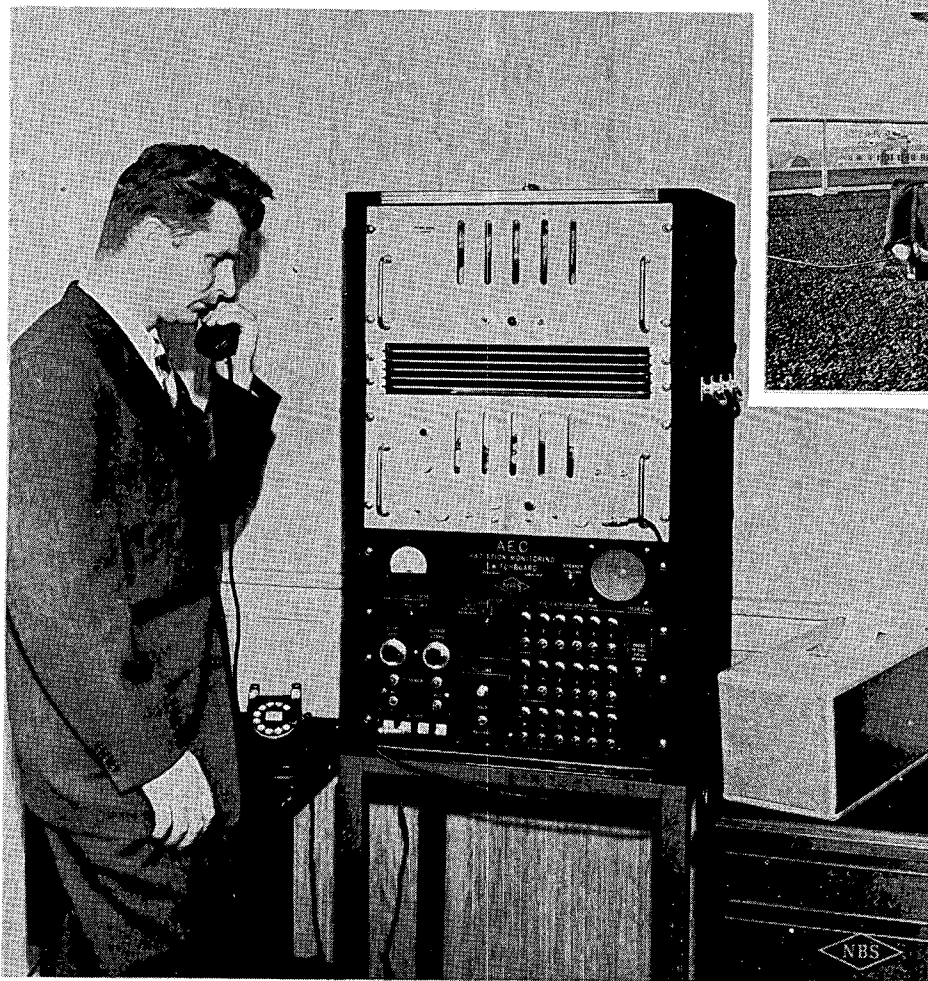

## PREFACE

Report NBS-4148 described a remote radiation-monitoring system developed for the Atomic Energy Commission and placed in operation at the Nevada Test Site in 1955. Since that time the equipment has been modified, and the modified equipment has been used in the 1957 test series at the Nevada Test Site. Report NBS-5124 describes these modifications and is therefore supplemental to NBS-4148. Since the demand for NBS-4148 has exhausted the supply, the question of reprinting it has arisen. However, it is considered preferable to incorporate in the reprint the modifications described in NBS-5124 and to delete or properly modify superseded parts. This has been done in this report. This report is therefore self-sufficient and will in general supersede reports NBS-4148 and NBS-5124.

The basic system was designed by the author and E. R. Saunders (now with the Federal Civil Defense Administration). Contributions were also made by H. O. Cline and W. Pearlman of the National Bureau of Standards and by R. W. Johnston of the Atomic Energy Commission.

# REMOTE RADIATION-MONITORING SYSTEM

## INTRODUCTION

At the request of the Division of Biology and Medicine, of the U. S. Atomic Energy Commission, a system has been developed by the National Bureau of Standards for the remote monitoring of gamma radiation. The equipment was first placed in operation to monitor fallout radiation during the Nevada bomb tests in the early part of 1955, and the latest equipment has been used in the 1957 tests. The system involves transmission of the radiation data by means of long-distance telephone lines for detector sites accessible by phone line and by means of direct field wire for stations within approximately 15 miles of the control stations and not accessible by commercial phone lines.

The equipment permits a single operator to obtain radiation data from stations located anywhere in the United States without leaving his desk. To challenge a station connected to a commercial telephone line, the operator simply phones the station in the usual manner for placing a long-distance call. The station automatically answers, sends in its data, and then hangs up. Field-line stations are similarly challenged by the operator from the control console.

## GENERAL DESCRIPTION

The remote radiation-monitoring system is comprised of several radiation-monitoring stations (Figs. 1 and 2) and one or more control stations (Fig. 3).

The radiation-intensity data from the detectors (Fig. 12) is in the form of a d-c voltage that is a function of the radiation intensity. This d-c voltage controls the frequency of an oscillator at the radiation-monitoring station. The oscillator frequency is thus a function of the radiation intensity and varies between about 800 and 1400 cps. The oscillator output is transmitted by means of long-distance telephone lines or direct field lines to the control station where the output frequency is read by means of a frequency counter and is printed on paper tape. A typical "read-out" tape is shown in Fig. 4. Zero calibrations (Cal 0), other calibrations (Cal 1, Cal 2, Cal 3), and a station identification signal (SI) are shown as well as readings from two detectors (Det 1 and Det 2) that cover different ranges. [Usually only one detector is used, the low-range detector being used for monitoring stations located outside the test area and the high-range detector (or both detectors) being used close in.] The radiation-intensity data are determined from the tape by comparing the readings with a calibration curve for the station.

402 047

The radiation-monitoring stations are completely under the control of the control station and consume no power except when challenged by the control station. Power is applied to the station for about two minutes for each challenge. Battery drain is therefore quite low, enabling the stations to remain unattended for long periods of time. With rare exception, the stations used over long-distance telephone lines in the 1955 and 1957 Nevada tests required no battery changes for the duration of the test series. (Of course, this was not the case for stations connected by direct field lines that were challenged at very frequent intervals.)

## RADIATION-MONITORING STATIONS

### General

The radiation-monitoring station shown in Figs. 1 and 2 is remotely challenged and "read out" by the control-station operator over long-distance telephone lines or over direct field lines. Figure 5 is a view with the lid of the battery box open. The battery box contains all the batteries required for operation of the equipment and also houses the remote data station unit (RDS-1A), the high-voltage supply for the detectors, and a ring box for use with telephone lines. Detectors and integrators, shown in Fig. 12, are also included with each radiation-monitoring station.

### Remote Data Station RDS-1A

(a) General. The remote data station includes the oscillator and relay circuitry and is shown in Figs. 6, 7, 8, and 18. Though it is a compact unit, it has been so designed that it is readily disassembled for maintenance. As will be noted in Fig. 8, the shelf that includes the electronic circuitry slides out once the back of the unit is removed.

(b) Oscillator. The oscillator (Fig. 18) converts the d-c signal from the detector-integrator circuit into a frequency shift. It consists of an input cathode follower and a d-c controlled multivibrator followed by a filter network and an output amplifier. For a d-c voltage change from 0 to 50 volts, the oscillator frequency shifts from about 800 to about 1400 cps. The frequency increases linearly with input voltage at the rate of approximately 12 cps per volt. Curves of the frequency stability of the oscillator are given in Fig. 21.

(c) Control-relay Circuitry. The control-relay circuitry has been designed to provide high reliability with minimum power consumption. A d-c signal of at least 22 volts is required across the "field-line" terminals (Fig. 18) to turn on the station. This direct current is fed down the line from the control station and must be of the proper polarity to actuate the particular station since a rectifier is included in the circuit to make the stations polarity sensitive. The polarity-sensitive circuit makes possible the use of two stations on the same line. The operator selects the station to be challenged by use of the proper polarity. A typical instance in which this feature results in line economy is one where it is desired to locate a station 10 miles from the control station and a

second one at half this distance. In this case a single 10-mile line can be run to the far station, and the close-in station can be tapped into the line.

Since the same field lines are used for both the challenging signal and the returning audio-information signal, RY1 is inserted between the two halves of the split balanced winding of the output transformer and is by-passed by a large capacitor. When RY1 is energized, its contacts close and apply  $7\frac{1}{2}$  volts to the thermal time relay RY2 through a pair of normally closed contacts of RY4. RY2 provides a 2-sec time delay and therefore serves to prevent line transients from energizing the stations.

Relays RY3 and RY4 serve to prevent multiple challenging if the d-c challenging signal is left on the line after the data transmission has been completed.

After voltage has been applied for 2 sec to the coil of RY2 through the contacts of RY1, the contacts of RY2 close and apply voltage to the coil of RY3. One set of RY3 contacts then applies voltage to the latch coil of RY5 and another set of RY3 contacts applies voltage to the coil of RY4 through the contacts of RY1. The normally closed contacts of RY4 then open and break the circuit of RY2, allowing the contacts of RY2 to open and drop out RY3. The thermal lag, or drop-out, of RY2 is sufficient to permit RY4 to operate despite the interruption of its coil circuit due to the opening of its normally closed contacts in series with the RY2 coil.

As long as the challenging signal is applied to the coil of RY1, RY4 is locked on through its own normally open contacts, and the normally closed contacts of RY4 remain open preventing operation of RY2. Under such circumstances, RY3 cannot be operated nor can the latch coil of RY5 be relatched. Therefore, even though the challenging voltage may remain on the line for a period longer than it takes for the station to complete its program and deenergize itself, the station will not become reenergized. When the contacts of RY1 open, RY4 drops out, and the station is then receptive to another challenge.

When the station has been successfully challenged, relay RY5 is latched on to completely energize the station. The timer motor, which is energized through contact RY5D, applies voltage every 10 sec to the stepper coil (RY6), causing the stepper to advance one position every 10 sec. As the rotor of RY6 is stepped around, the wiper on deck A applies d-c voltages to the oscillator input corresponding to station identification and calibrations. On steps 8 and 9 the deck A wiper is connected to the detector-integrator circuits of detectors 1 and 2, respectively, to obtain voltages corresponding to the radiation intensities.

The wiper of deck A is connected to the input of the oscillator; thus the oscillator frequency is dependent upon the values of the station identification, calibration, and detector output voltages that are applied to the various steps. When the stepper is in the "home" position the oscillator input floats. Step 1 provides a zero calibration (Cal 0), causing the oscillator to generate the base frequency of about 800 cps. Station-identification voltage (SI) is applied on step 2, followed by Cal 0 on step 3, Cal 1 on step 4, Cal 2 on step 5, Cal 3 on step 6, Cal 0 on step 7, Det 1 output on step 8, and Det 2 output on step 9. The SI and calibration voltages are obtained from the precision resistive divider network shown in Fig. 9 which is across a voltage regulator tube.

402 049

When the stepper leaves step 9, all the data have been received, and the unit is ready to be deenergized. On step 10 the D-deck wiper applies  $7\frac{1}{2}$  volts to the reset coil of RY5, which releases the mechanical latch and allows the contacts to return to normal. This removes power from the oscillator and high-voltage supply. The armature of RY5D then makes contact with its back contact and picks up  $7\frac{1}{2}$  volts to run the timer. The timer therefore continues to run until it has advanced the stepper one more step to the home position. The entire station is then completely reset and is in stand-by condition ready for another challenge.

(d) Panel Controls. The several front panel controls have been included to facilitate station installation, calibration, and test. The start push button (PB1, Figs. 6 and 18) is paralleled across the contacts of RY1 for energizing the station manually. The step push button (PB2) enables manual stepping of the program stepper to any desired step. The motor switch (TG1) enables removal of power from the timing motor so that the stepper can remain on any desired position during calibration or test. The detector ground switch is used to ground momentarily the oscillator input during calibration and test. The home indicator light and push button are used to indicate when the stepper is on the home position. The output-amplitude adjustment (AMPL) is also mounted on the front panel.

#### High-voltage Supply

The high-voltage supply for the detectors is shown mounted on the battery box partition in Fig. 10, and the circuit diagram is shown at the right in Fig. 18. A regulated relaxation oscillator type high-voltage supply (Nucleonics Company of America, type HV1) with a positive 900-volt output is followed by two separate regulating networks to provide doubly regulated and adjustable high voltage for the two detectors that can be operated at each station. The  $1\frac{1}{2}$ - and 180-volt supplies provide power for the 900-volt supply.

Each of the high-voltage regulator networks consists of a dropping resistor, a temperature-compensating thermistor, a condenser, and an adjustable voltage-regulator tube (Anton BS404) that permits adjustment of the voltage between the limits of 620 and 720 volts. With the arrangement used, an output of 50  $\mu$ amp is obtainable from the 900-volt supply.

#### Battery Requirements

Twelve  $1\frac{1}{2}$ -volt dry batteries (General Dry Battery 4LIS or equivalent) and four 45-volt dry batteries (Burgess 5308 or equivalent) are required for each radiation-monitoring station. They are used as follows: ten  $1\frac{1}{2}$ -volt batteries (two series strings of five each paralleled) for the  $7\frac{1}{2}$ -volt supply; one  $1\frac{1}{2}$ -volt battery for filaments (negative grounded); one  $1\frac{1}{2}$ -volt battery for cathode follower filament (V2 of Fig. 18); and four 45-volt batteries connected in series for 180-volt supply.



## Ring Box

The ring box RB1 (Fig. 11) is a self-answering plug-in device used when operating radiation-monitoring stations over telephone lines. When a normal telephone call is placed, the operator (or automatic dial board) places a 20-cps ring signal on the line. The ring box essentially answers the phone by responding to this 20-cps signal. In response to the ring signal, the ring box connects a low resistance across the line, thereby extinguishing the operator's supervisory light as would occur when a normal telephone is answered. The ring-box circuit also energizes the radiation-monitoring station and connects the station output to the telephone line for transmission of its program. When the program is completed, the station is automatically deenergized and the ring box "hangs up."

The detailed operation of the ring box is as follows: The 20-cps ring signal is applied to the "Tel Line" terminals of Fig. 18. This signal is fed to the ring box through pins 8 and 9 of the Jones plug connector and is applied across the coil of relay RY12 through a 2- $\mu$ f condenser. This closes the contacts of RY12 and applies 7 $\frac{1}{2}$  volts from pin 3 of the connector to the coil of RY11 through the normally closed contacts of RY13. RY11 then pulls in and locks its coil across the 7 $\frac{1}{2}$ -volt circuit through one of its own normally open contacts, RY11C. RY11B connects a 50-ohm 1-henry retardation coil directly across the line. The low resistance of the retardation coil serves to supply the answering signal as mentioned above. The coil inductance is sufficient to prevent loading of the a-c circuit. The closing of contacts RY11A shunts the contacts of RY1 in the remote data station (through pin 4) and thus turns on the station. The station then proceeds through its program as described, transmitting its signals down the telephone line through pins 6 and 10 and the d-c blocking condensers.

When the program stepper reaches step 10, 7 $\frac{1}{2}$  volts is applied to the reset coil of RY5 and through pin 2 to the coil of RY13. This turns off the station and opens the RY13 contacts. The opening of the RY13 contacts allows RY11 to drop out, disconnecting the retardation coil from the line, thus simulating the hanging-up of a telephone. This indicates a completed call to the telephone operator (or automatic dial board), and the proper steps are taken at the telephone switchboard to restore the line. Relay RY13 is deenergized when the program stepper advances to the home position. Upon the completion of this sequence of operations, the station is completely reset.

## Detectors

The detectors used are shown in Fig. 12, and the detector circuits are shown in Fig. 13. The rectangular detector (type LR) at the top covers the range from 10 to 30,000 mr/hr and the cylindrical detector (type VLR) in the center covers the range from 0.3 to 100 mr/hr. These figures, of course, are quite arbitrary since both types of detectors are capable of detecting, with reduced accuracy, radiation levels below and above these limits. The detectors are halogen-filled Geiger counters, Anton type BS-212 for the LR detector and Anton type BS-1 for the VLR detector. Both are used as current integrators with integrating networks of roughly 5-sec time constant. The LR detector used an external integrator (small cylinder at bottom of Fig. 12); whereas the inte-

grator for the VLR is contained in the detector housing. The detectors are supplied with regulated high voltage from the high-voltage assembly in the battery box as shown in Fig. 18.

The detectors are operated to give a maximum d-c output voltage of about 50 volts, which corresponds to a maximum current of about 7  $\mu$ amp for the LR detector and 5  $\mu$ amp for the VLR detector. The halagon counters are wrapped in approximately 0.012 in. of lead before being inserted in the lucite housings to reduce the energy dependence. The over-all accuracy of the detectors, as operated, is estimated to be approximately 20 per cent.

### Calibration

The primary calibration consisted of calibrating the detectors on the standard  $\text{Co}^{60}$  calibrating range at the NBS. For radiation levels below the lower limit of the range,  $\text{Co}^{60}$  sources were used together with thimble-chamber type ionization chambers.

As discussed earlier, the output frequency of the remote data stations is a function of the radiation intensity. Therefore the frequency output was plotted as a function of the known radiation intensity at the detector. Then the field calibration sources SR and MR were inserted in the holes in the LR detector, and the output frequencies were noted and located on the primary calibration curve to give the radiation intensities corresponding to the different calibrating holes. This was done for a number of detectors to determine that the LR detectors were reasonably similar. Table 1 was then prepared. The column of mr/hr for the SR source gives the radiation intensity that exists at the detector with the SR source in the various calibrating holes 1 through 5\* (source position 1 is the hole closest to the detector). For low radiation levels the sources were located at distances of 1, 2, and 4 meters from the detectors; the corresponding radiation levels are recorded in Table 1.

The radiation intensities for the SR and MR sources were obtained in the manner described above. The intensities for the SB and MB sources were calculated from the SR and MR source data by multiplying by the ratios of the source strengths. Since the SB,MB source set and the SR,MR source set are of approximately equal intensities, two similar sets of sources were available for field use.

The primary calibration procedure for the VLR detectors was similar to that for the LR detectors except that a calibrating jig was slipped over the detec-

---

\*This statement is not strictly accurate since the radiation levels indicated in Table 1 are the intensities of isotropic radiation from a uniformly distributed field that would give the same detector output as the calibrating source. This differs from the intensity at the detector resulting from the calibrating source since the detectors are most sensitive to radiation for a source normal to the detector and least sensitive to radiation from a source along the axis of the detector. The intensities given in Table 1 are, therefore, corrected values using a weighted integration of the detector response (Figs. 26 and 27), based on a plane isotropic source.

tor as shown in Fig. 14 because it was not practical to make the jig a part of each VLR detector. The VLR-detector calibration data are also given in Table 1.

The energy and directional dependence of the detectors are shown in Figs. 26 and 27. The data were obtained using heavily filtered X radiation.

In field operations the field calibration sources were used to obtain curves of output frequency vs. radiation intensity as shown in Fig. 15. The calibrating holes in the LR detectors and two jigs identical to that shown in Fig. 14 for the VLR detectors were used for this purpose. In addition, the various voltage calibration points, Cal 0, Cal 1, Cal 2, Cal 3, and SI, were located on the curves. Subsequently, shifts in the calibration were indicated by shifts in the calibration points. Since the calibration data are automatically received at the control station together with the radiation-intensity data, the corrections for calibration shifts can be made without revisiting the detectors. This calibration does not compensate for shifts in the detector sensitivity, but this has been found to be quite stable.

### CONTROL STATION

The control station (Fig. 3) serves to control all stations in the radiation-monitoring system. It consists of the radiation-monitoring switchboard (Figs. 3, 16, and 19), read-out equipment, and a standard commercial telephone.

Stations to be challenged are selected by the control-station operator, and all data are routed through the control station. The route-selector switch on the radiation-monitoring switchboard is switched to the proper position to select either stations on commercial telephone lines (Tel Line) or stations connected by field lines (Field Line).

In order to challenge a station on a long-distance telephone circuit, the control-station operator switches the route selector to Tel Line and then places a regular station-to-station long-distance telephone call to the station to be challenged. The station automatically answers and sends in its data. The incoming data are fed through a band-pass filter and amplifier on the switchboard and then to the read-out equipment. In order to avoid noise from the telephone transmitter while data is being received, the control-station operator switches the hold-release switch to hold and then hangs up the telephone receiver. The hold-release switch places a low resistance across the telephone line simulating the off the hook position of the telephone so that the telephone operator (or automatic telephone switchboard equipment) does not disconnect the line. After the remote-station data have been received, the control-station operator switches the hold-release switch to "release" to release the telephone line.

To challenge a field line station, the operator sets the route-selector switch on Field Line, depresses the field-station selector corresponding to the desired station (A, B, C, etc.) and then presses the "field call" key. The field call key connects 45 volts direct current to the selected field line to challenge the station. The incoming data are routed through the band-pass filter (the 400-2000 cps band pass of the filter is a result of past history; 700-1500 cps is now more appropriate) and amplifier to the read-out equipment.

Two identical and independent filter-amplifier combinations are included on the switchboard so that one can serve as a stand-by. The output level can be set by means of a front panel control and monitored visually on the output-level meter and audibly by means of the speaker. The information transmitted from the radiation-monitoring stations to the control station is decoded by determining the frequency of the transmitted signal by means of a time-gated frequency counter [such as the EPUT Meter manufactured by the Berkeley Scientific Company, Richmond, Calif. (center bottom, Fig. 3)]. The frequency counter counts the incoming cycles for a 1-sec interval, then displays the count in digital form, and repeats this mode of operation continuously. In addition, the output of the frequency counter is applied to a digital scanner (center top, Fig. 3) and then to a printer (at right, Fig. 3) to provide a printed record of the frequency data as shown in Fig. 4. The radiation intensity is determined by comparing these data with the calibration curve for the station as shown in Fig. 15.

It is sometimes desired, in the interest of economy, to operate several radiation-monitoring stations over a single field-line pair. Such an occasion would arise where several stations are relatively close together but are located an appreciable distance from the control station. In such a situation a single field-line pair can be run to a multiple-station selector (Fig. 17), in the vicinity of the stations, and radial lines can be run from the multiple-station selector to the data stations.

When the common field line is selected at the control station and the call key is depressed, relay RY20 pulls in, pulling in RY21 and advancing the stepper RY22 one position. This places 45 volts across the field-line pair that connects step 1 to a remote data section. If the stepper remains on this step for at least 2 sec, permitting the time delay relay (RY2 of Fig. 18) to operate, the data station is energized and transmits its program to the control station. After the program is completed, the station turns itself off in the usual manner except that the 45-volt battery remains connected across the line so that the relays RY1 and RY4 of Fig. 18 remain energized. However, by momentarily depressing the call key 10 more times, the operator advances the stepper in the multiple-station selector to its home position. This removes the 45 volts from the line, completely deenergizing the data station so that it is prepared to accept additional challenges.

To select a station that is connected to some other step position, the operator momentarily depresses the control-station call key a number of times corresponding to the desired step. Though the 45-volt energizing signal is then applied to each of the steps as it passes through them, the stations will not be energized unless the stepper is permitted to rest on the step for at least 2 sec. Thus the operator is able to select any station that is routed through the multiple-station selector without energizing any other stations. The polarized relay feature can be used with the multiple-station selector, just as it can for direct field-line connection, to operate two stations over a single field-wire pair. The  $7\frac{1}{2}$ -volt battery is connected across the line through the stepper off-normal contacts so that this voltage appears at the control station whenever the stepper is on the home position. This enables the operator to properly reset the multiple-station selector.

## COMMENTS

The 1400-cps upper frequency limit was selected because of the increasing use of a 1600-cps disconnect signal on telephone lines. The lower limit of 800 cps was chosen because of unexplained difficulties encountered on some telephone lines below 700 cps.

Carrier shifts as high as 40 cps have been experienced on suppressed carrier lines, but they vary slowly and are therefore essentially constant during the challenge of a monitoring station. The shift is therefore corrected for by the calibration readings (see Fig. 15).

Because of company policy, the American Telephone and Telegraph Company has proposed that the Bell System telephone companies supply ring boxes (Fig. 22) similar to those of Figs. 11 and 18 rather than have the ring boxes supplied by the Government. In addition, they propose that the telephone hold switch be supplied by the telephone company (Fig. 23). The American Telephone and Telegraph Company has issued instructions to its personnel in this matter in their letter dated June 7, 1955 (Appendix I to this appendix). This is a policy matter to which there are no technical objections.

TABLE 1—DETECTOR CALIBRATIONS FOR  
SR, MR, SB, AND MB SOURCES\*

Source position†	SR source, mr/hr	MR source, mr/hr	SR source, mr/hr	MR source, mr/hr
VLR Detector Calibration‡				
4 meters	0.02	0.27	0.02	0.30
2 meters	0.08	1.1	0.07	1.2
1 meter	0.31	4.2	0.29	4.8
5	2.5	28	2.4	32
4	6.8	79	6.4	90
3	18		17	
2	52		49	
1	170		160	
LR Detector Calibrations‡				
4 meters	0.02	0.25	0.02	0.29
2 meters	0.09	1.0	0.08	1.2
1 meter	0.35	4.8	0.33	5.4
5	16	180	15	200
4	50	600	47	690
3	120	1,700	120	1,900
2	380	4,800	360	5,500
1	1,400	19,000	1,300	22,000

\*Relative source strengths: SR = 1.00 (approx. 0.2 mc); MR = 13.6; SB = 0.94; MB = 15.5; SO = 0.96; B = 141.

†Source position 1 is calibration hole closest to detector.

‡As of May 15, 1957; at later dates, correction should be made for decay of the Co<sup>60</sup> sources.

TABLE 2—ADJUSTMENT PROCEDURE FOR  
REMOTE DATA STATION RDS-1A

- 1 Install ring box
- 2 Install 820-ohm resistor across field-line terminals
- 3 Connect: (a) Field-line terminals to radiation-monitoring switchboard  
(b) Telephone line terminals to scope  
(c) Telephone line terminals to voltmeter (2.5-volt a-c scale)
- 4 Test remote start
- 5 Set on Cal 3; adjust R1 for 1400 cps; press Det ground and adjust R2 for 800 cps  
Readjust Cal 3 to 1400; press Det ground and readjust to 800 cps  
Repeat until 1400 cps and 800 cps are both obtained
- 6 Tighten lock pots
- 7 Recheck Cal 3 = 1400 cps, Cal 0 = 800 cps (Cal 0 obtained by depressing Det ground)
- 8 Remove field-line connection
- 9 Adjust choke (VIC-12) for Cal 0 amplitude = Cal 3 amplitude
- 10 Set amplitude potential for Cal 0 = 1.2 volts RMS as read on voltmeter (see 3c)
- 11 Observe Cal 0 and Cal 3 wave form and peak-to-peak voltage (~3 volts) on scope
- 12 Tighten amplitude lock potential
- 13 Check Cal 2 wave form and peak-to-peak voltage (~5½-6 volts) on scope
- 14 Check timer motor

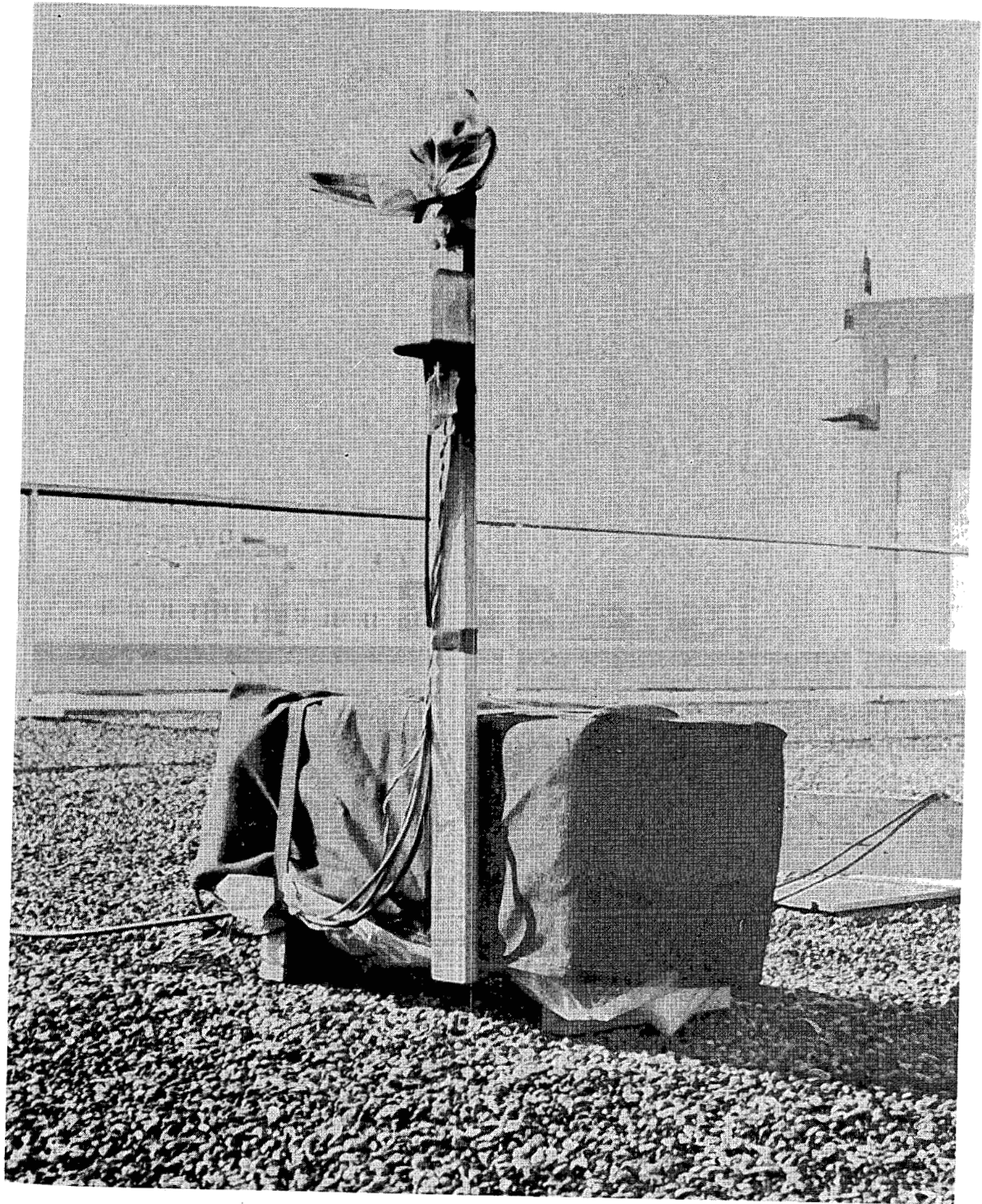

Fig. 1—Typical radiation-monitoring station installation.

402 057

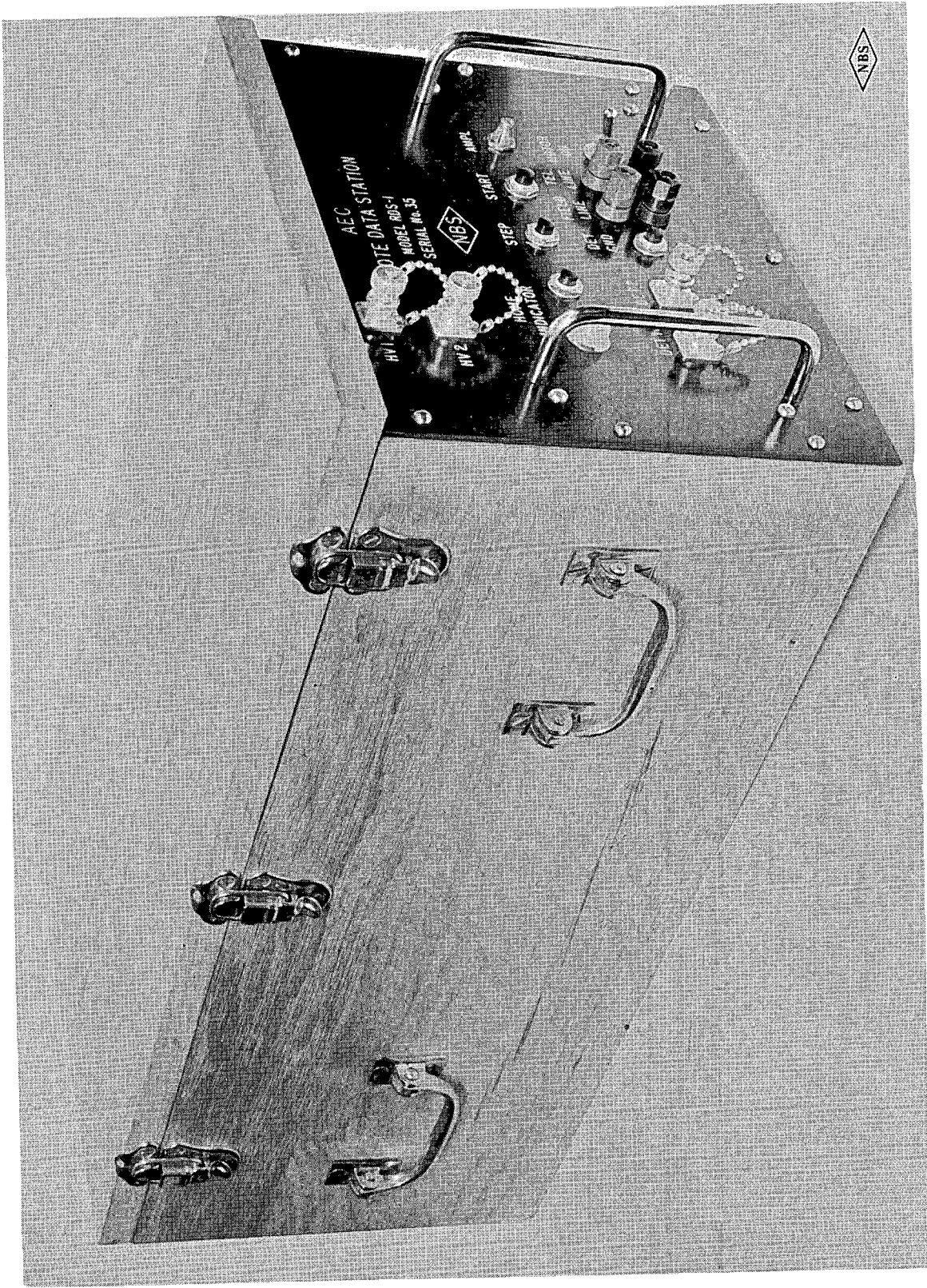

Fig. 2 — Radiation-monitoring station (without detectors).

402 058



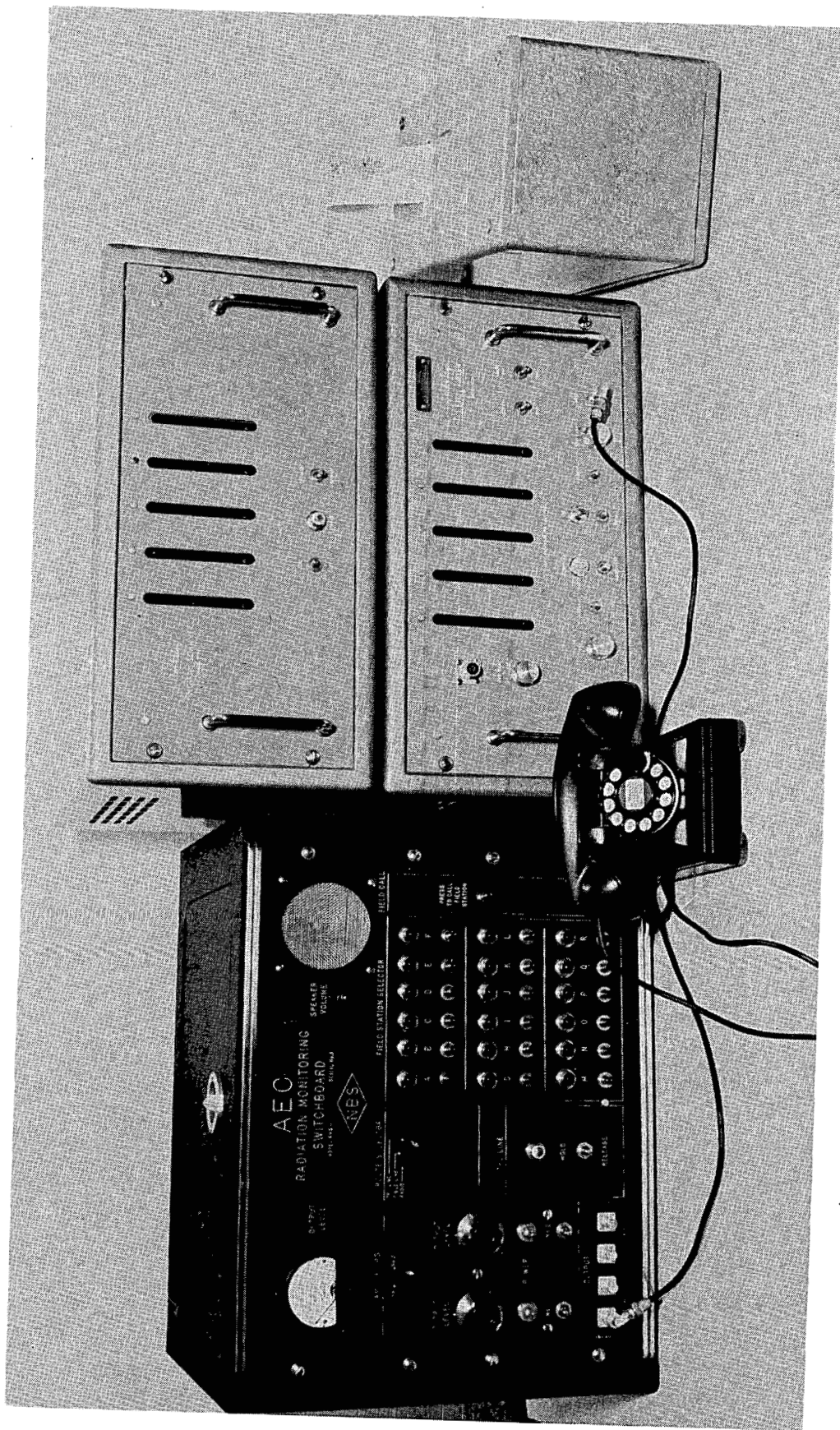

Fig. 3—Control station. Radiation-monitoring switchboard at left; frequency counter and digital scanner in center; printer at right.

402 059

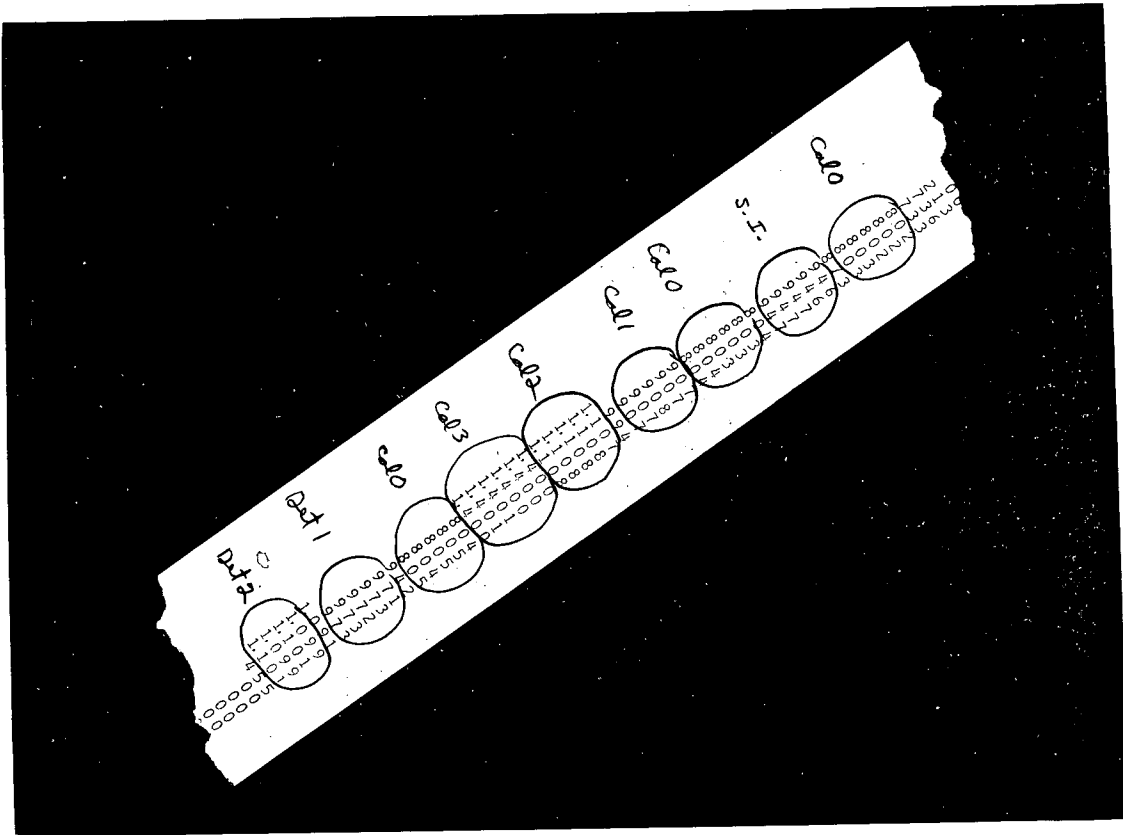

Fig. 4—Typical read-out tape.

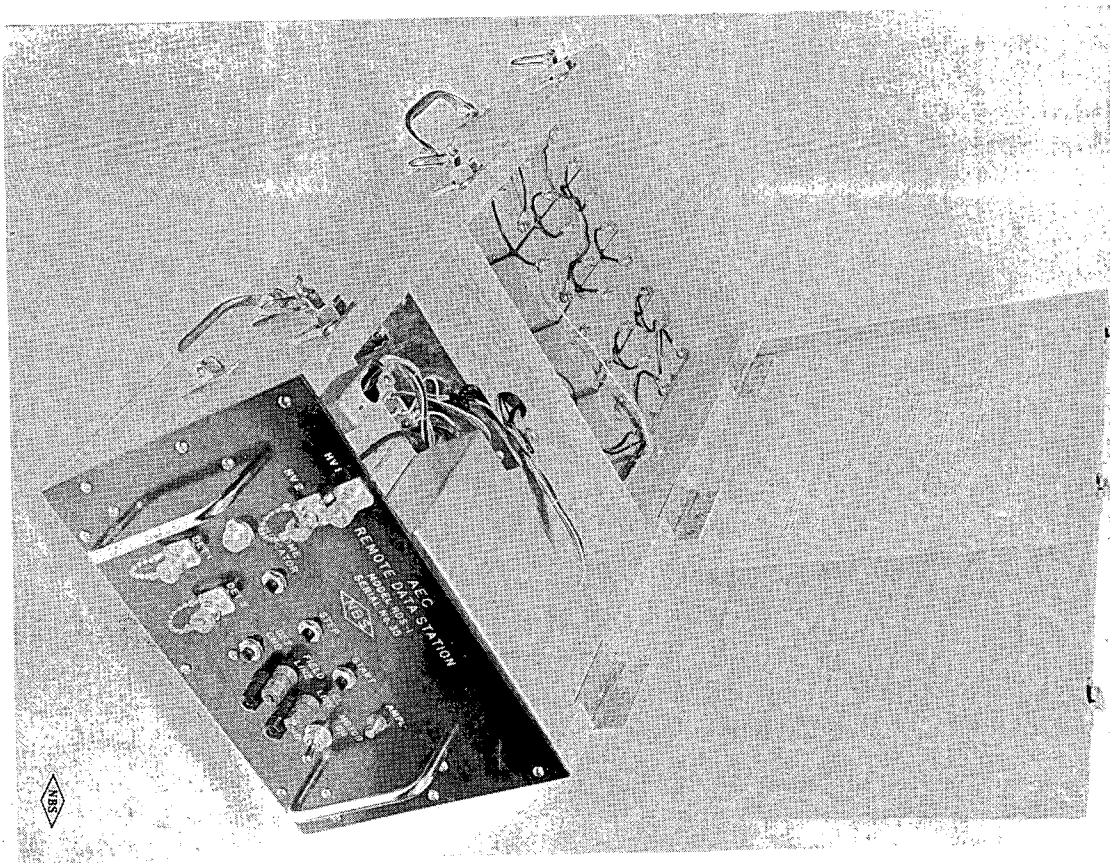

Fig. 5—Radiation-monitoring station showing batteries, remote data station, and ring box.

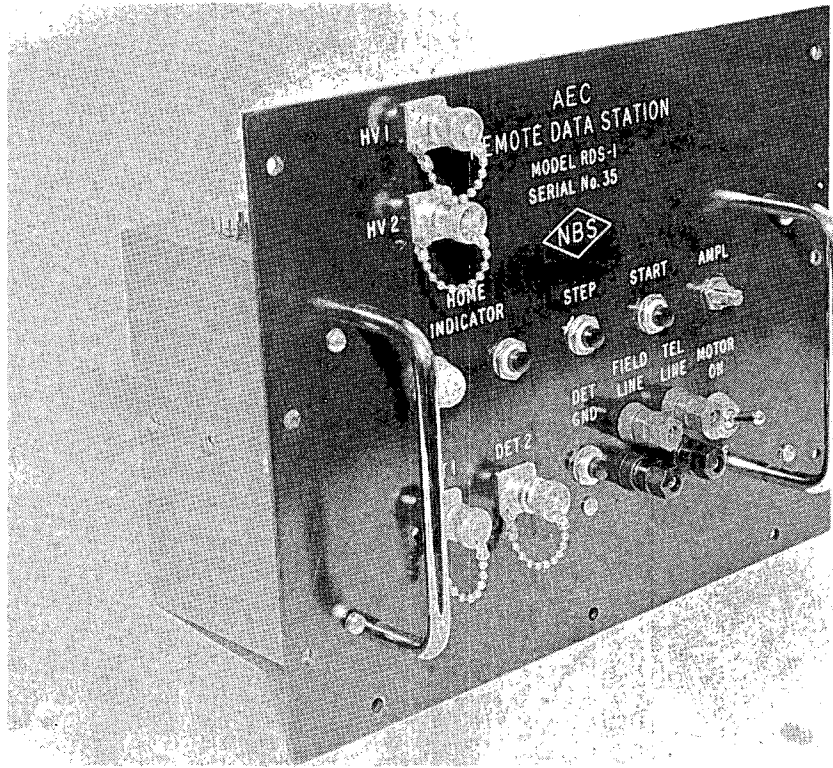

Fig. 6—Remote data station, front view.

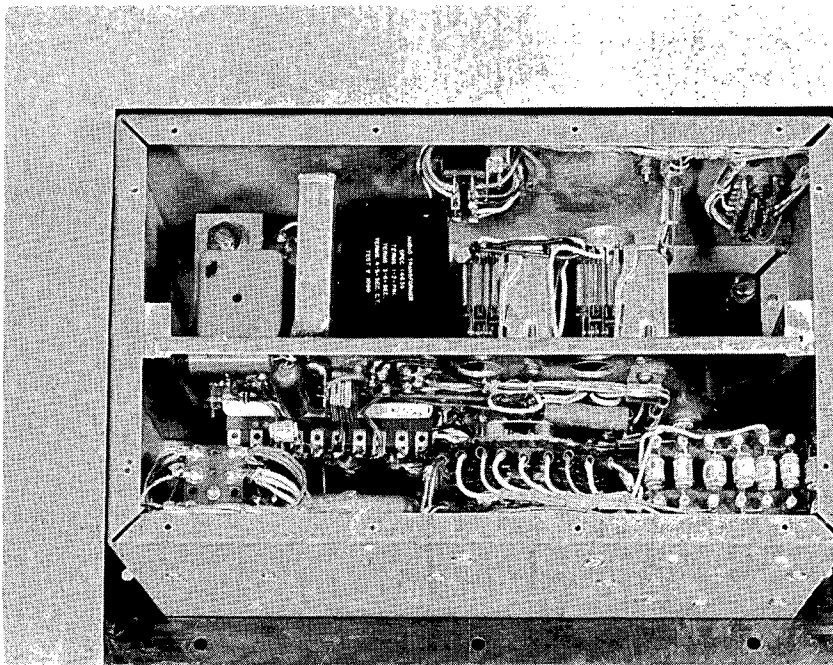

Fig. 7—Remote data station, rear view.

402 061

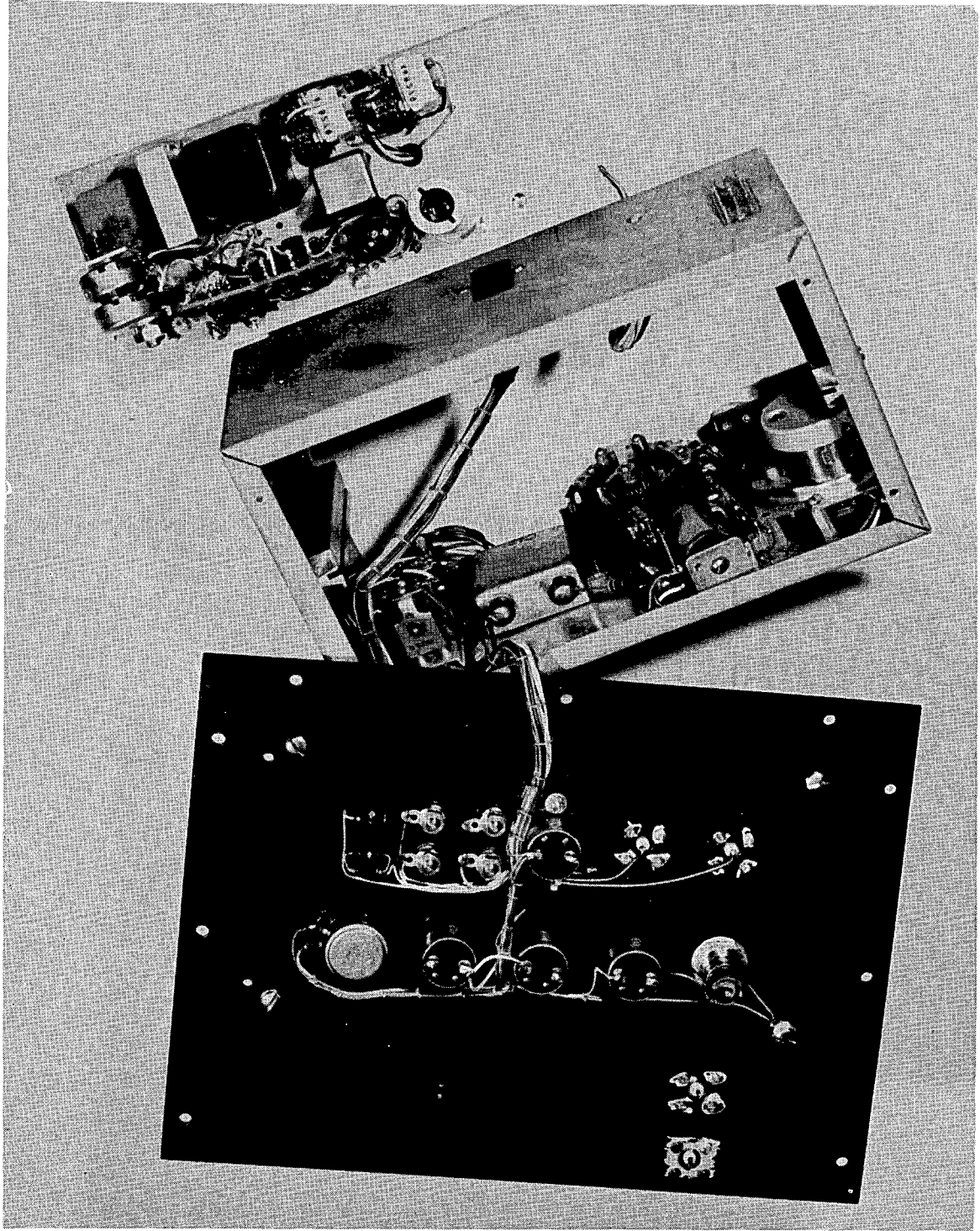
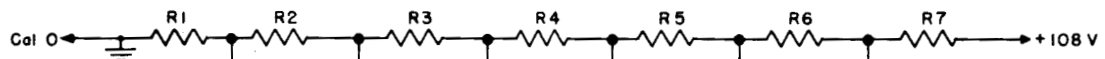

Fig. 8—Remote data station showing how unit is disassembled by removing front panel and rear cover.



RDS NO	R1	R2	R3	R4	R5	R6	R7			
1	1	SI	4	5	Cal 1	20	Cal 2	30	Cal 3	▲
2	2	3	—	—	—	—	—	—	—	—
3	3	2	—	—	—	—	—	—	—	—
4	4	1	—	—	—	—	—	—	—	—
5	5	—	—	—	—	—	—	—	—	—
6	—	1	SI	4	—	—	—	—	—	—
7	—	2	3	—	—	—	—	—	—	—
8	—	3	2	—	—	—	—	—	—	—
9	—	4	—	—	—	—	—	—	—	—
10	10	Cal 1	—	—	—	—	—	—	—	—
11	—	1	4	—	15	—	—	Cal 2	30	—
12	—	2	3	—	15	—	—	—	—	—
13	—	3	2	—	5	—	10	—	—	—
14	—	4	1	—	5	—	—	—	—	—
15	—	5	—	—	5	—	—	—	—	—
16	—	—	1	SI	4	—	—	—	—	—
17	—	—	2	3	—	—	—	—	—	—
18	—	—	3	2	—	—	—	—	—	—
19	—	—	4	1	—	—	—	—	—	—
20	—	10	—	—	—	—	—	—	—	—
21	—	—	1	4	—	5	—	—	—	—
22	—	—	2	3	—	—	—	—	—	—
23	—	—	3	2	—	—	—	—	—	—
24	—	—	4	1	—	—	—	—	—	—
25	—	15	—	—	—	—	—	—	—	—
26	—	10	5	—	—	SI	4	—	—	—
27	—	—	—	—	2	—	3	—	—	—
28	—	—	—	—	3	—	2	—	—	—
29	—	—	—	—	4	—	—	—	—	—
30	—	20	—	—	—	—	—	—	—	—
31	—	—	Cal 2	1	SI	4	—	25	—	—
32	—	—	2	3	—	—	—	—	—	—
33	—	—	3	2	—	—	—	—	—	—
34	—	—	4	1	—	—	—	—	—	—
35	—	—	5	—	—	—	—	—	—	—
36	—	—	—	—	1	SI	4	—	20	—
37	—	—	—	—	2	—	3	—	—	—
38	—	—	—	—	3	—	2	—	—	—
39	—	—	—	—	4	—	1	—	—	—
40	—	—	10	—	—	—	—	—	—	—
41	—	—	—	—	1	—	4	—	15	—
42	—	—	—	—	2	—	3	—	—	—
43	—	—	—	—	3	—	2	—	—	—
44	—	—	—	—	4	—	1	—	—	—
45	—	—	—	—	5	—	5	—	10	—
46	—	—	15	—	1	—	4	—	—	—
47	—	—	—	—	2	—	3	—	—	—
48	—	—	—	—	3	—	2	—	—	—
49	—	—	—	—	4	—	—	—	—	—
50	—	—	—	20	—	—	—	—	—	—

SEE NOTE 4

**NOTES**

1. ALL VALUES OF RESISTANCE GIVEN IN KILO-OHMS (K)
2. ALL RESISTORS IRC - W W10 - J 1%
3. COLOR CODE (WIRE)
  - a. ORANGE - STATION IDENTIFICATION
  - b. YELLOW - CALIBRATION NO. 1
  - c. GREEN - " NO. 2
  - d. BLUE - " NO. 3
  - e. WHITE - " NO. 0 (GRD)
- ▲ 4. FOR RDS-1 R7 = 50K  
FOR RDS-1A R7 = 75K

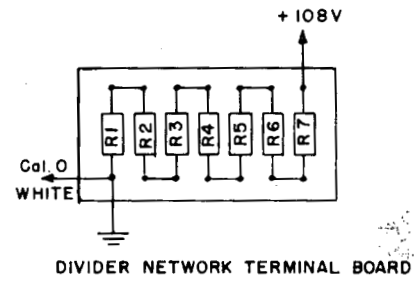

Fig. 9 — Voltage divider networks for remote data stations.

402 063

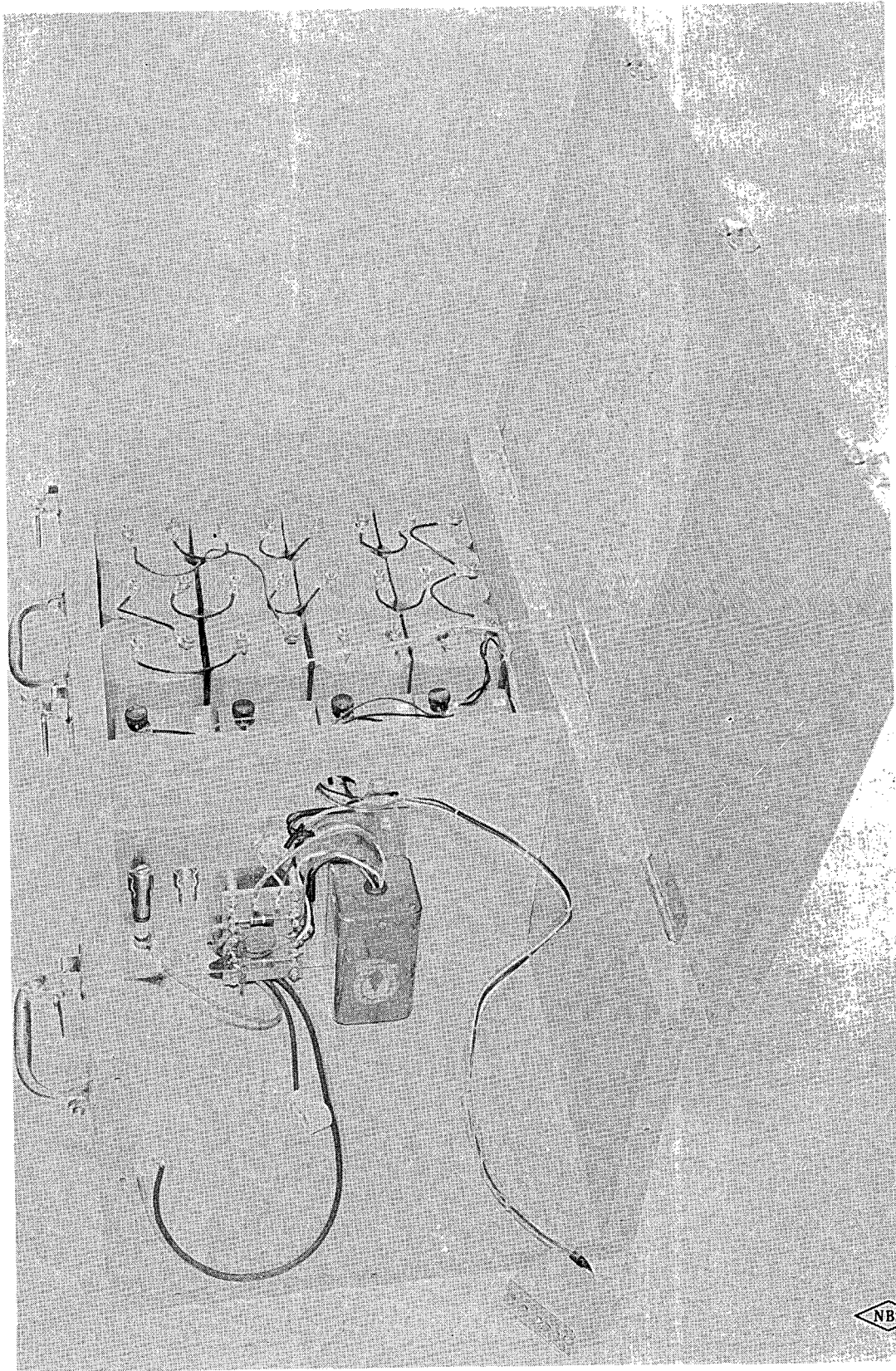

Fig. 10—Battery box showing high-voltage supply mounted on partition.

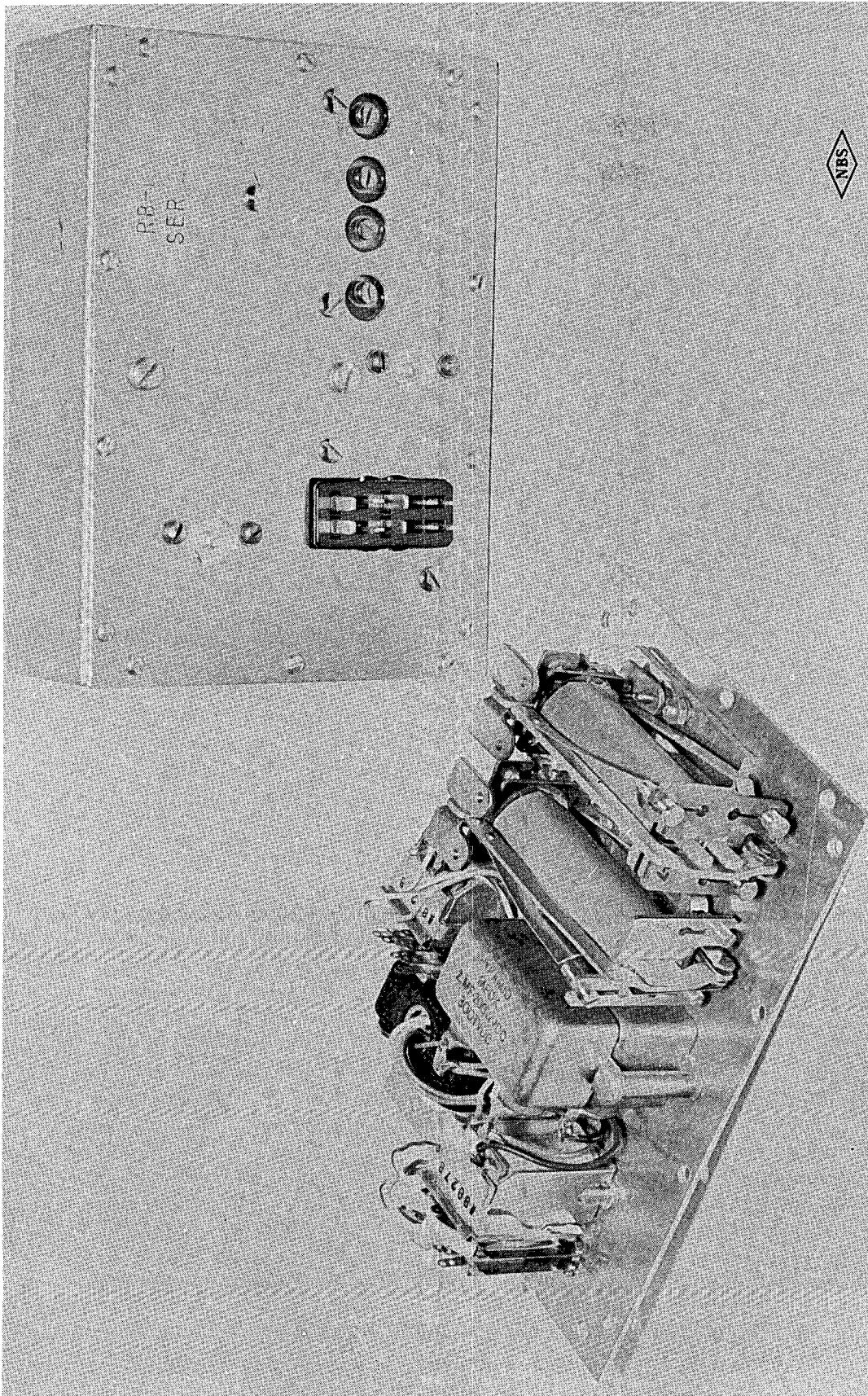

Fig. 11 — Ring box for use with telephone lines.

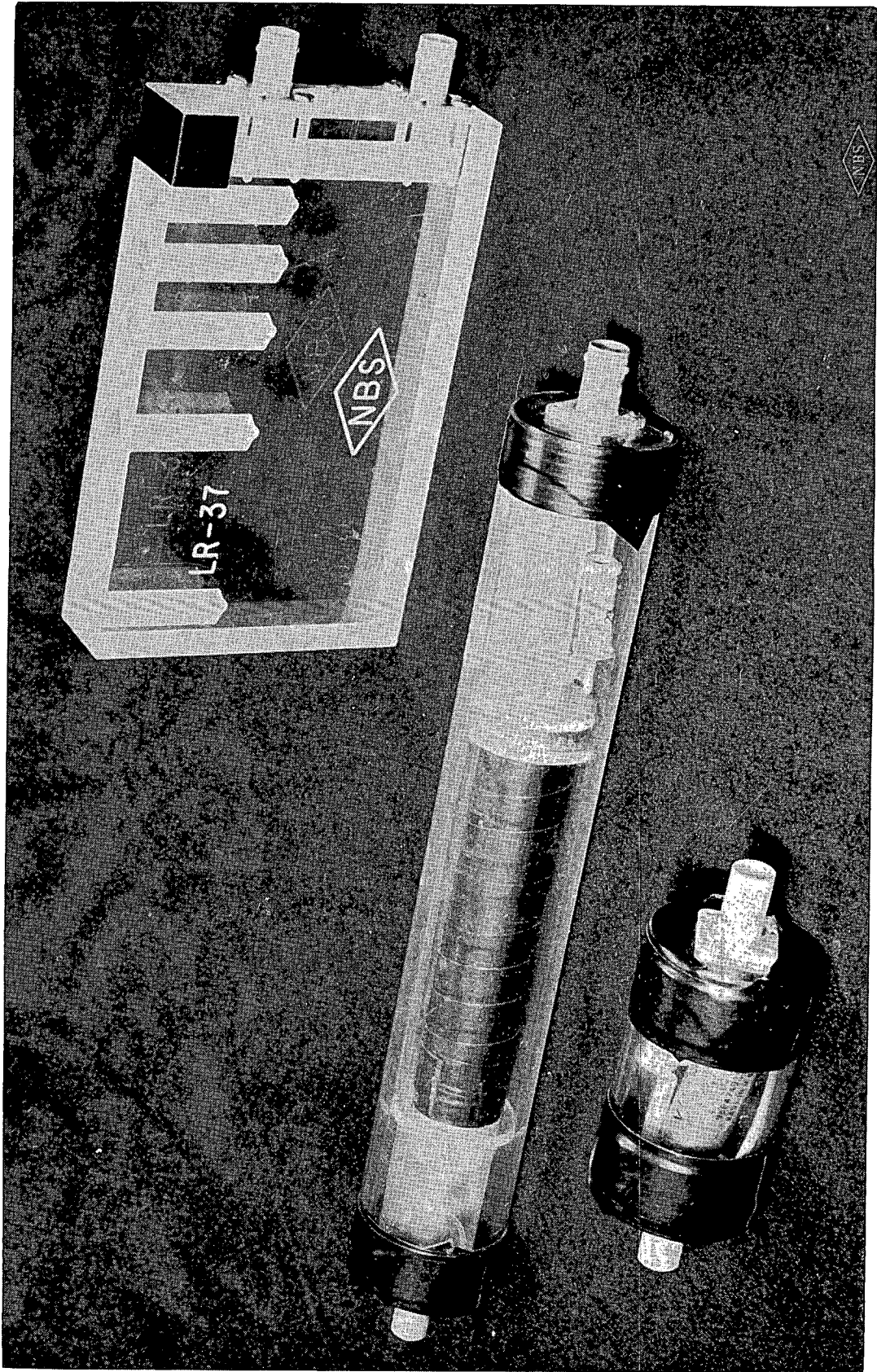

Fig. 12—Detectors and integrators. At rear is the moderate sensitivity detector (type LR), its integrator is shown in front; the sensitive detector (type VLR) is shown in the center.



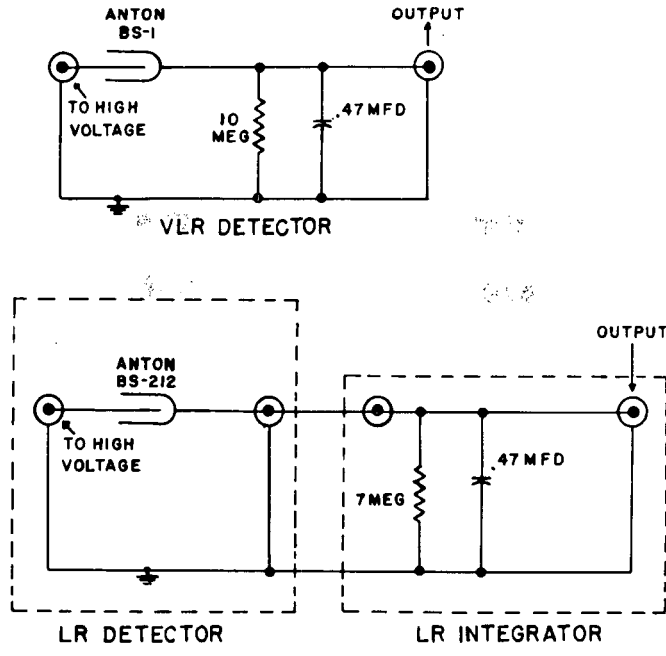

Fig. 13—Detector circuits.

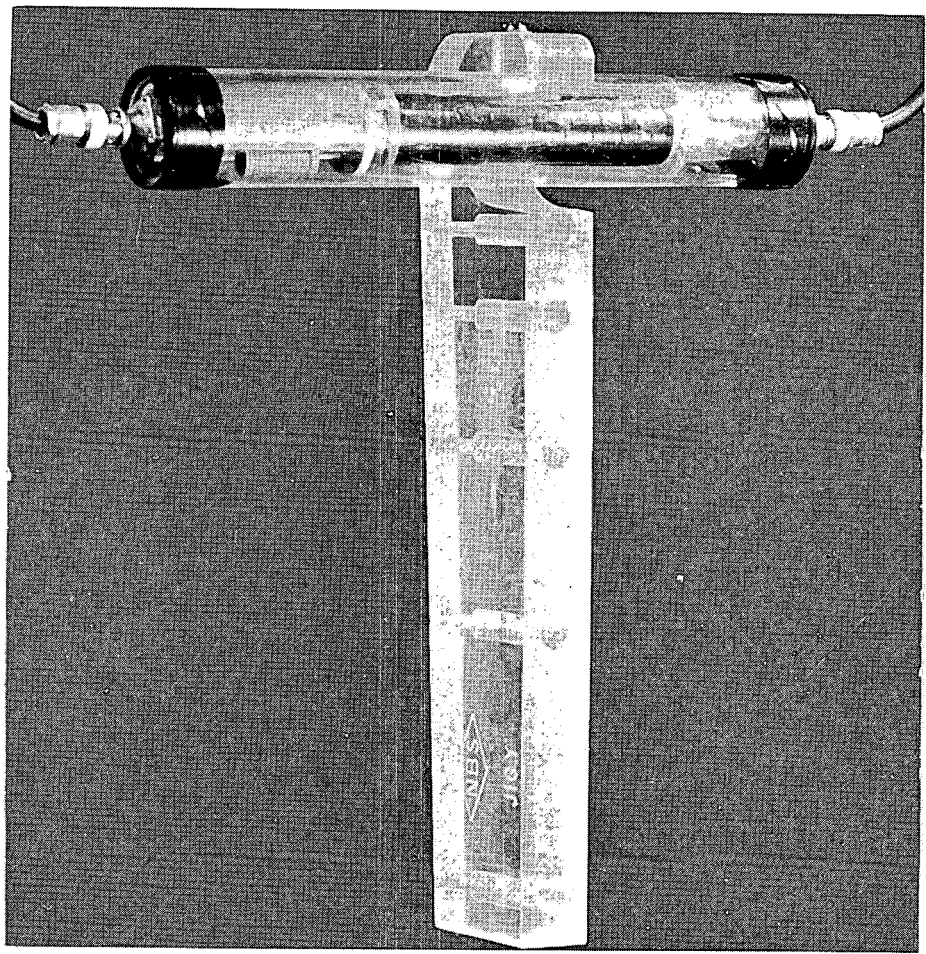

Fig. 14—Calibration jig in place for calibration of VLR detector.

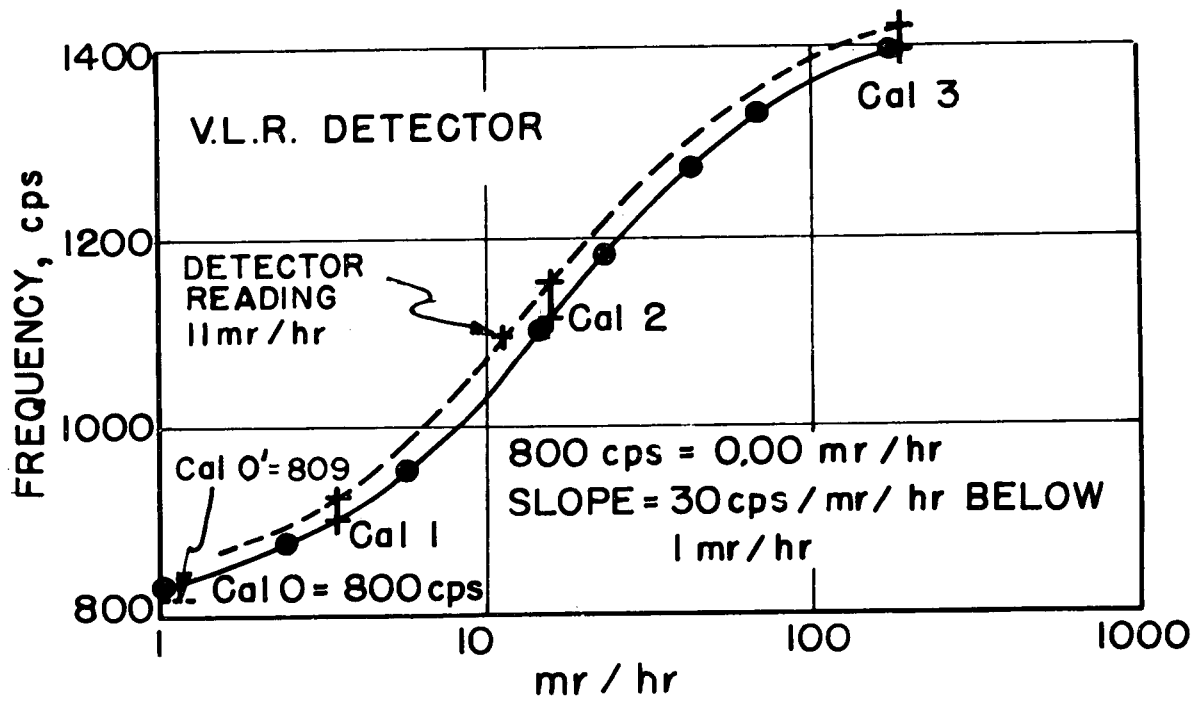
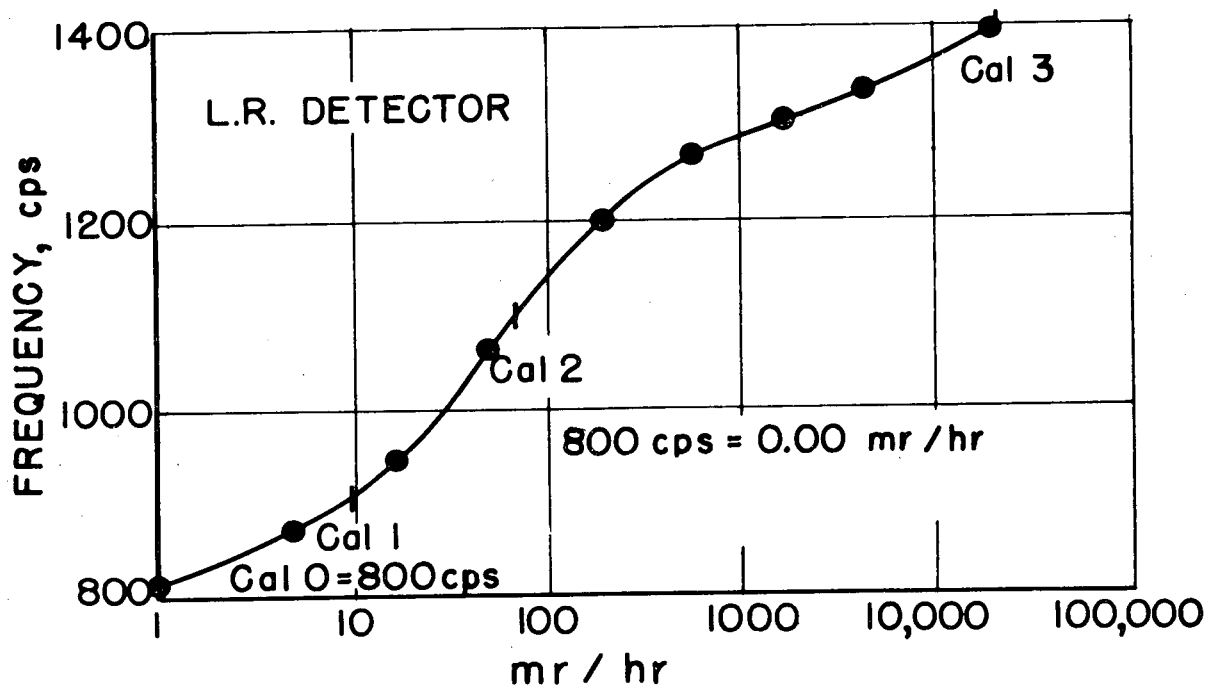

Fig. 15—Typical detector calibration curves. Solid curves are original calibration curves; dashed curve is plot of read-out and shows how calibration points are used to obtain corrected curve.

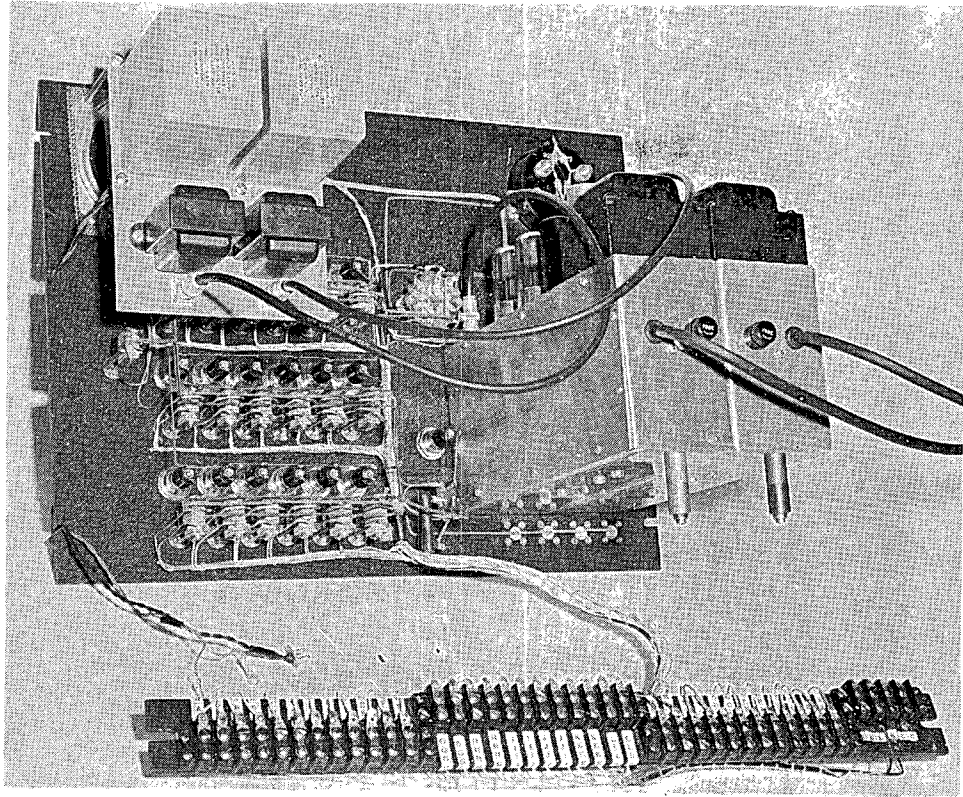
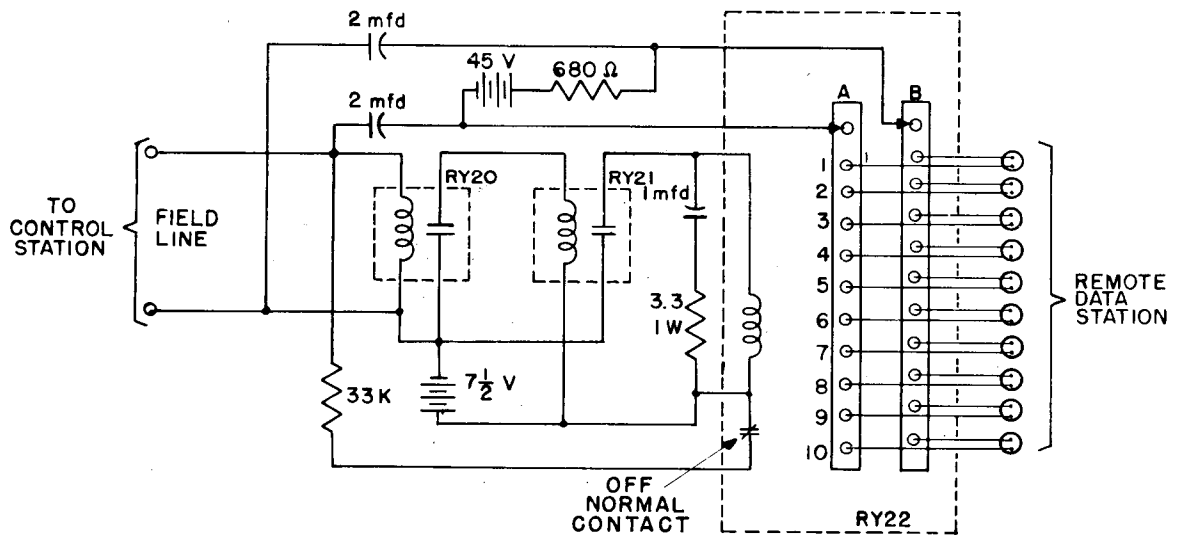

Fig. 16—Radiation-monitoring switchboard, rear view. (Front view is shown in Fig. 3.)



- RY20— ALLIED CONTROL CO. INC., TYPE RHS-DC, 5000  $\Omega$
- RY21— C. P. CLARE & CO., TYPE N, 40  $\Omega$
- RY22— AUTOMATIC ELECTRIC, STEPPER TYPE 44, 2  $\Omega$



Fig. 17—Multiple-station selector for operation of several radiation-monitoring stations over a single pair of field lines.

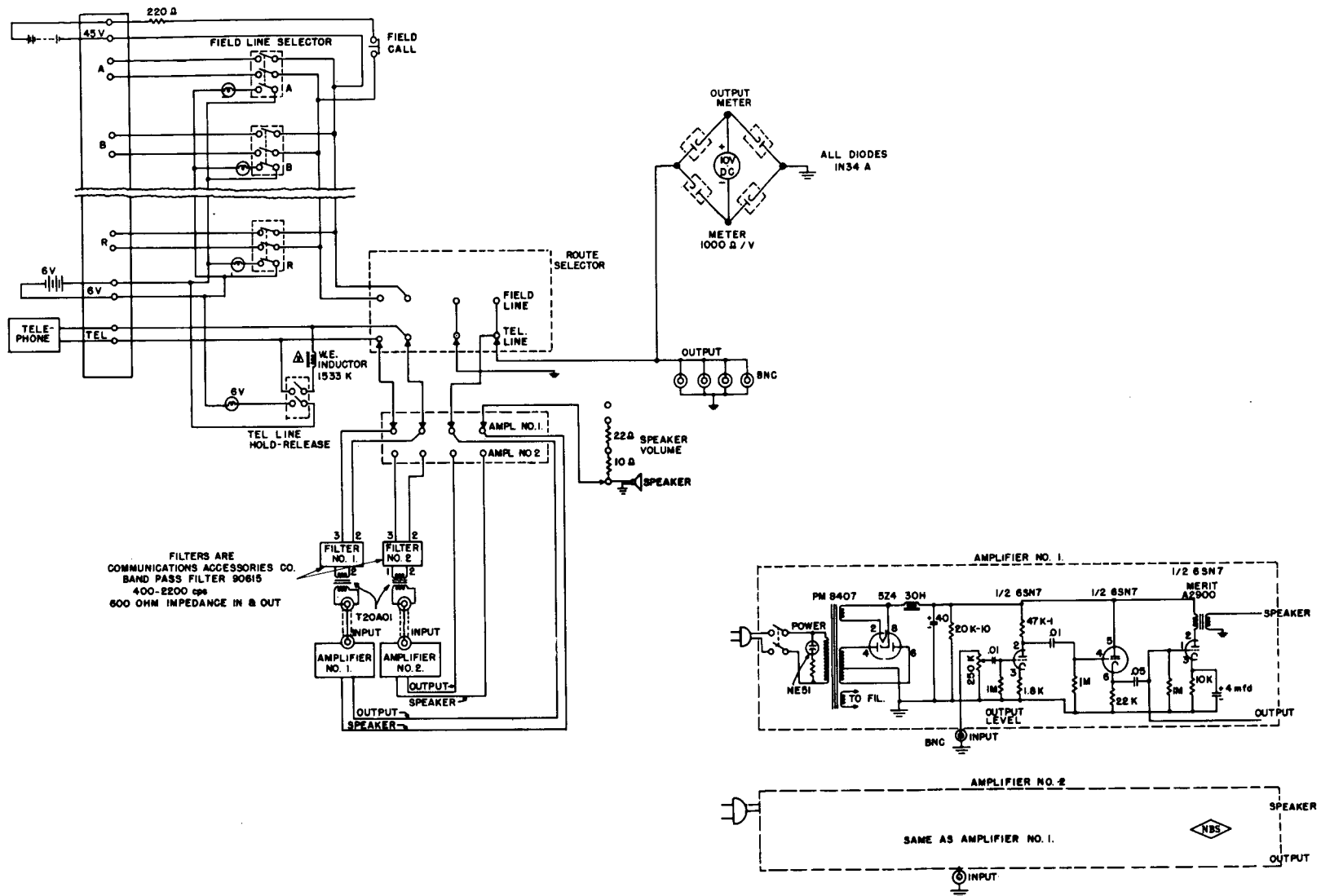
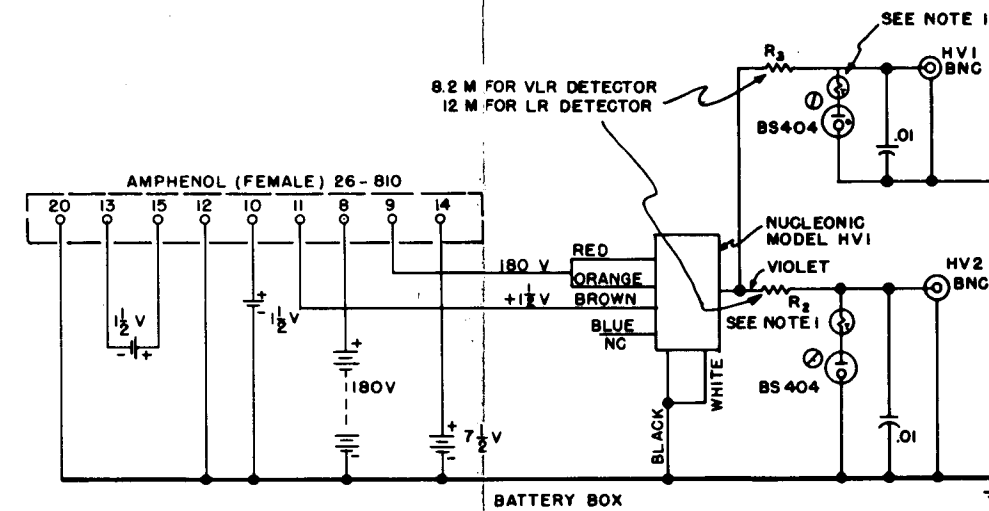
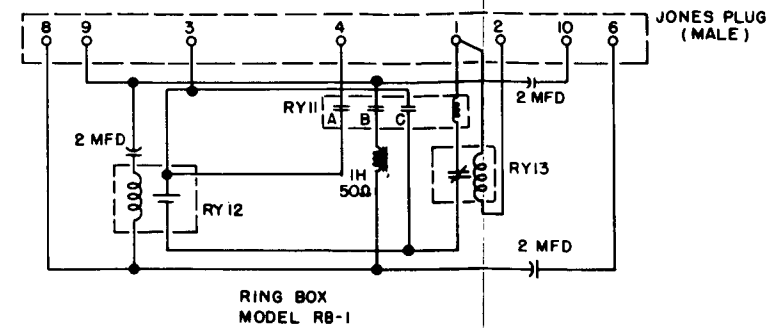
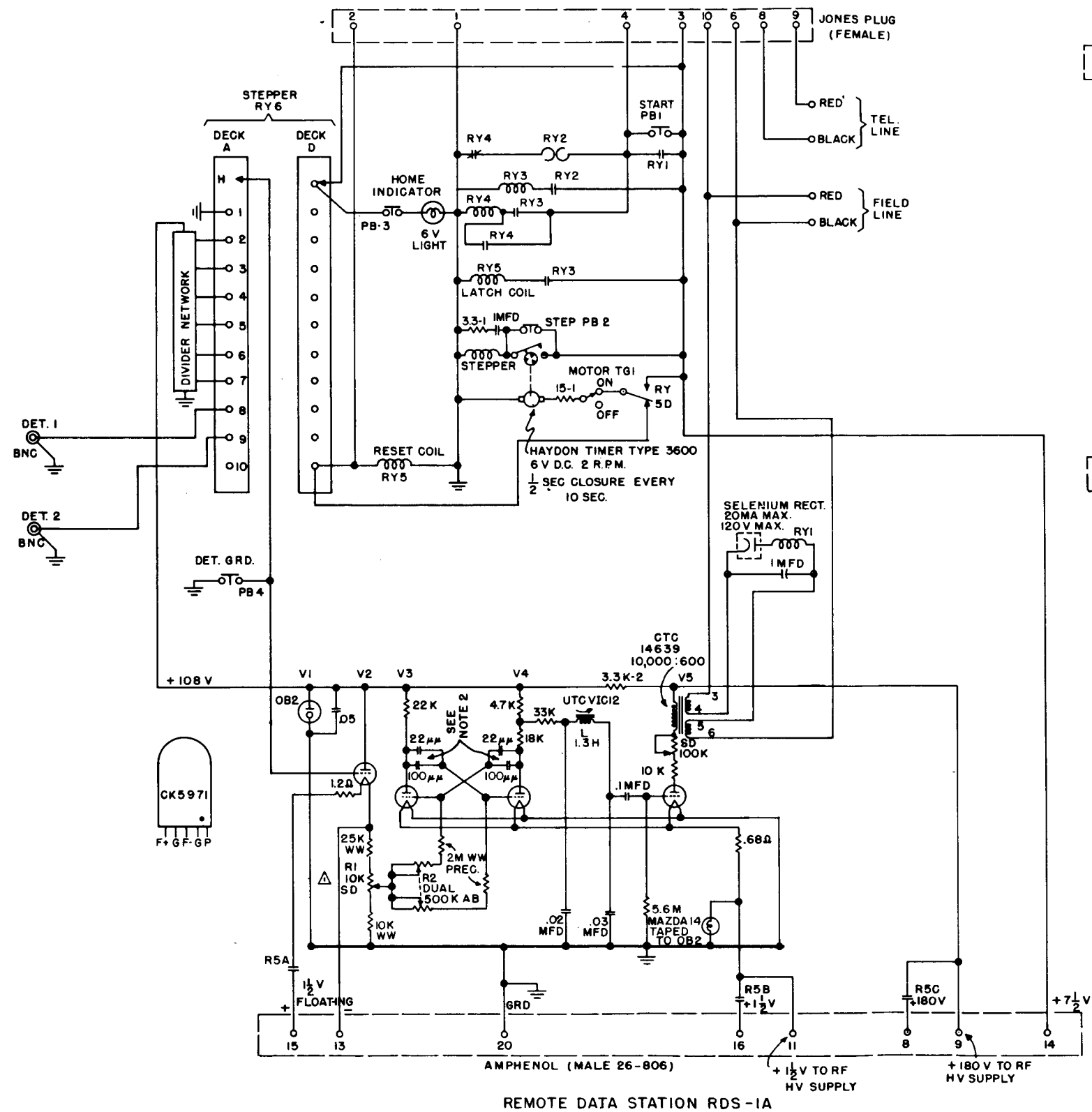

Fig. 18—Radiation-monitoring switchboard circuit diagram.



RELAY NO.	MFG'R	TYPE	COIL VOLTAGE	COIL RES. (OHMS)	REMARKS
RY1	SIGNAL ENG'G ALLIED CONT'L	100 RHS-DC	22 V. D.C.	5000	USE EITHER TYPE
RY2	AMPERITE CO.	6N02T	6V. D.C.	8	2 SEC. DELAY
RY3	C.P. CLARE & CO.	N	6V. D.C.	40	
RY4	C.P. CLARE & CO.	N	6V. D.C.	40	
RY5	POTTER & BRUMFIELD	LK17D	6V. D.C.	40	LATCHING WITH ELEC. RESET
RY6	AUTOMATIC ELECTRIC	44	6V. D.C.	2	STEPPING SWITCH
RY11	C.P. CLARE & CO.	N	6V. D.C.	40	
RY12	WESTERN ELECTRIC	J7	20 cps 45V RMS	1000	RING RELAY
RY13	C.P. CLARE & CO.	N	6V. D.C.	40	

- NOTES:
- GLOBAL THERMISTOR TYPE 763F, R=120K AT 25°C, B=2050
  - 125 μμ = SILVER MICA  
22 μμ = CERAMIC N750
  - V2, V3, V4, & V5 = CK5971
- REFERENCE PLANS
- NC-114 VOLTAGE DIVIDING NETWORK
  - NA-169 BATTERY WIRING
  - NA-170 CONVERSION PLAN

Fig. 19—Remote data station RDS-1A.

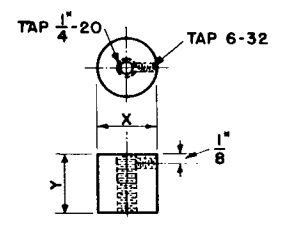
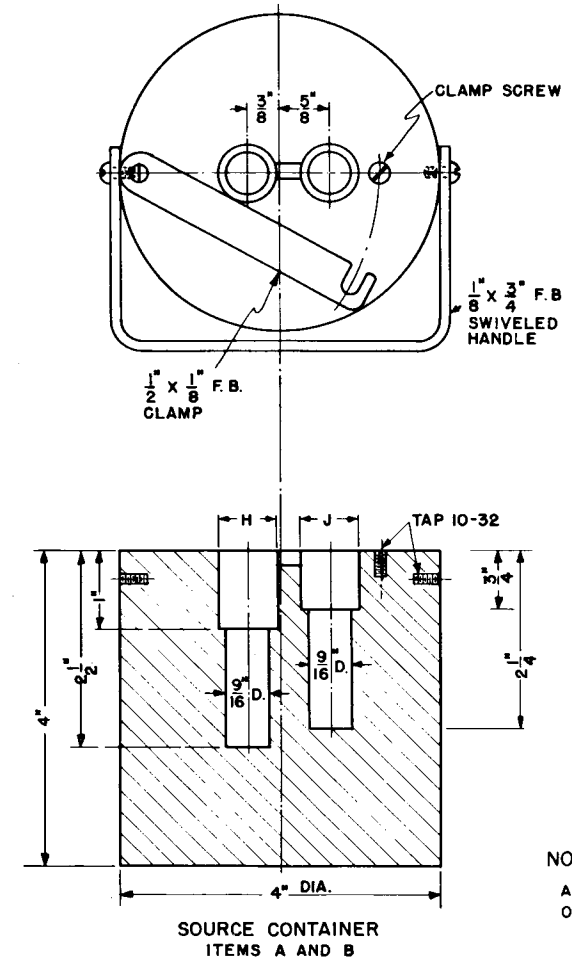

PLUGS  
ITEMS C, D, E, & F

ITEM	X	Y
C	.740"	3/4"
D	.740"	1"
E	.690"	3/4"
F	.690"	1"

X TOLERANCE ± .002"

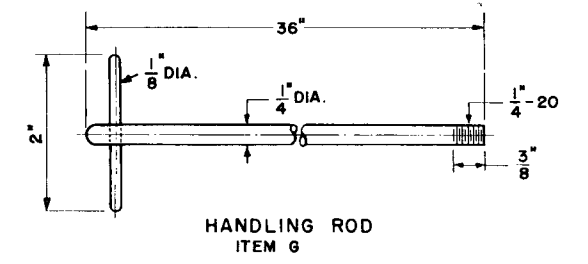

HANDLING ROD  
ITEM G

NOTE:  
ALL ITEMS TO BE MADE  
OF STAINLESS STEEL

ITEM	H	J	TOLERANCE
A	.750	.750	± .002
B	.700	.700	± .002

Fig. 20—Calibration source containers.

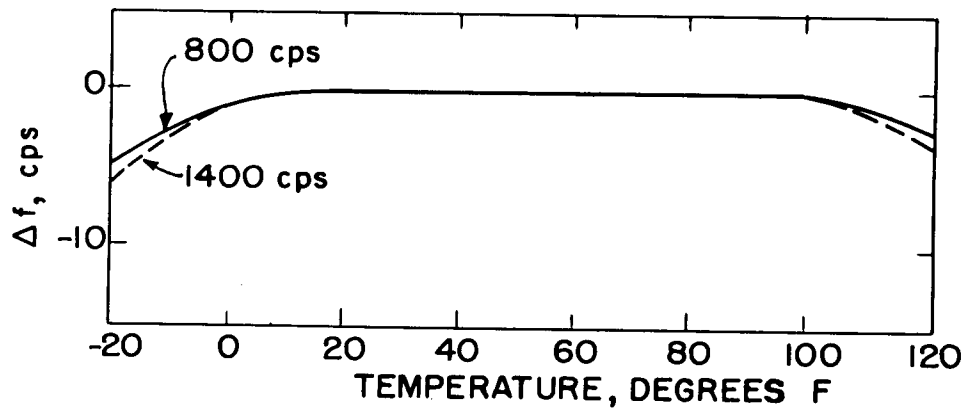
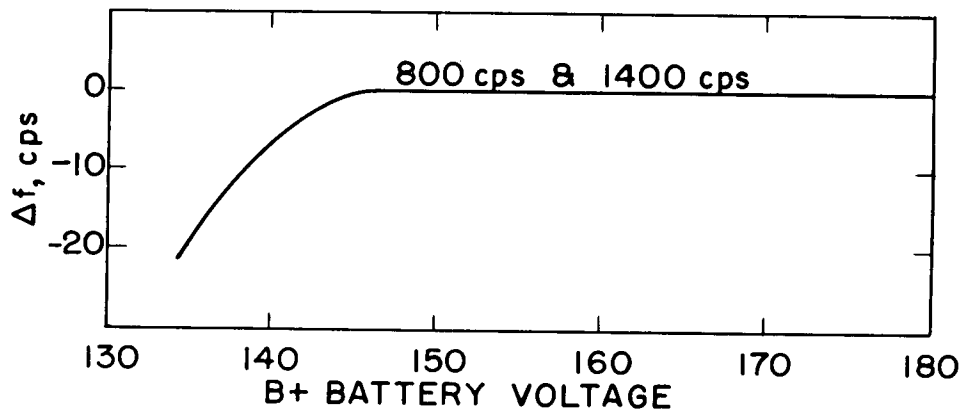
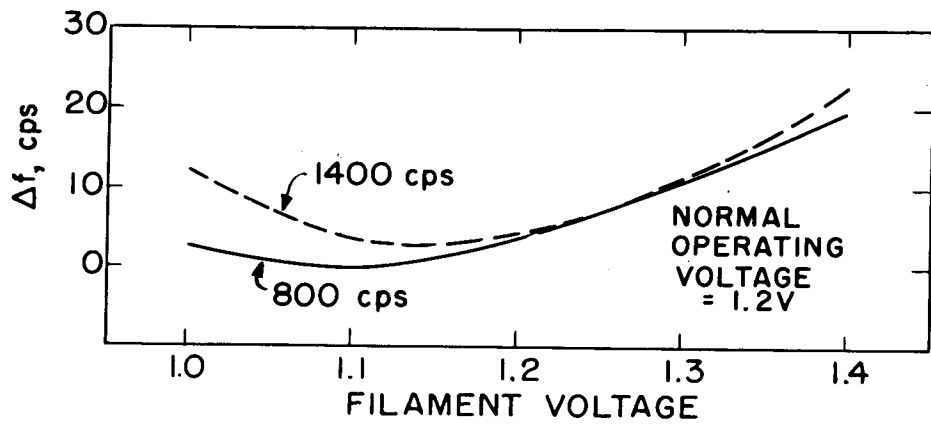

CHANGE IN FREQUENCY VS  
 FILAMENT VOLTAGE  
 B+ BATTERY VOLTAGE  
 TEMPERATURE

Fig. 21—Oscillator stability.

402 073

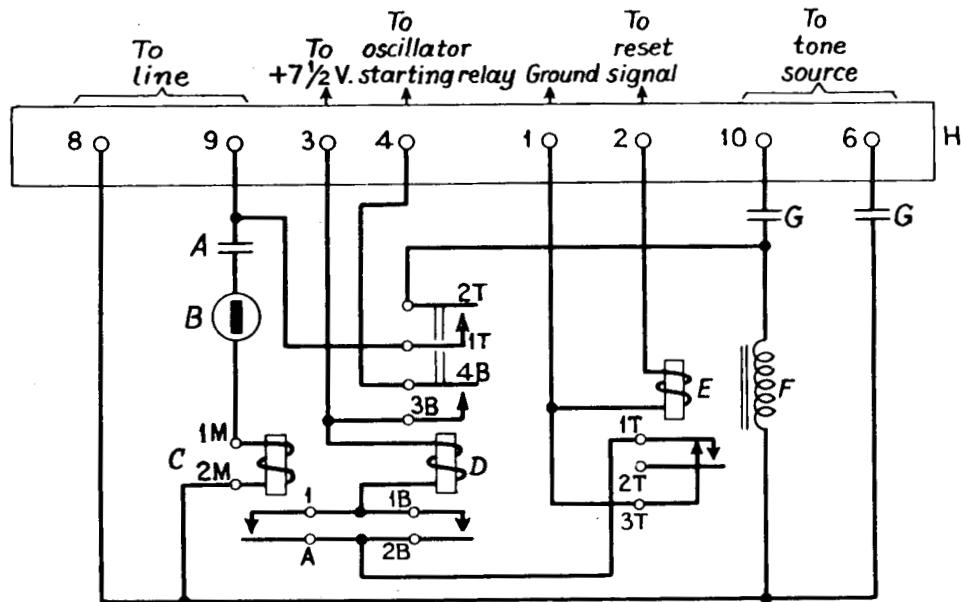

**NOTES:**

Designation	Part	
A	441A	Condenser - 1Mfd.
B	8A	Thermistor
C	J7	Relay
D	U1350	Relay
E	U1230	Relay
F	274C, D, R or U	Inductor
G	473E	Condenser - 2Mfd.
H		Jones Plug (Male)

Fig. 22—Line terminating equipment, remote station (American Telephone & Telegraph Co.).

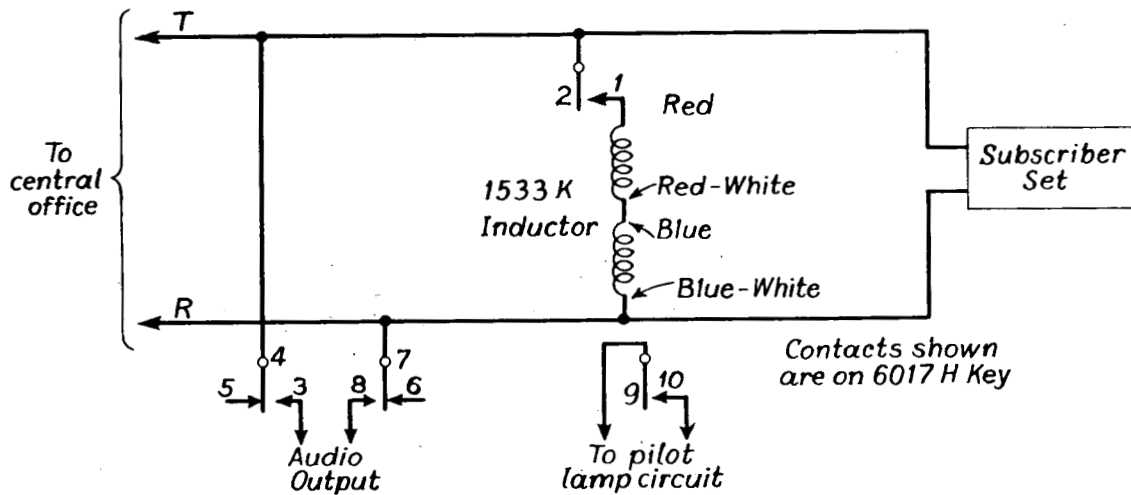

**NOTE:** 1533K Inductor may be mounted inside 6017H Key Box if Section 11-12 of terminal strip inside box is cut away.

Fig. 23—Line terminating equipment, control station (American Telephone & Telegraph Co.).



12 EACH  
4L1S

4 EACH 5308

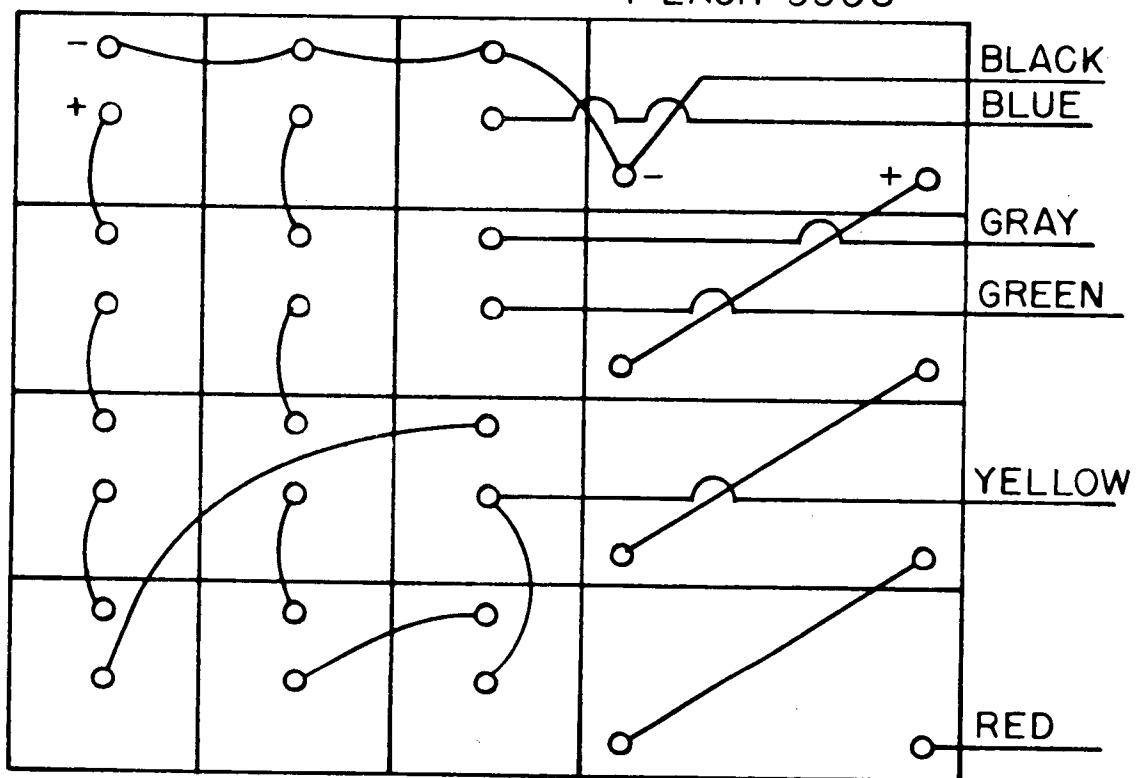

Fig. 24—Battery wiring for remote data station RDS-1A.

402 075

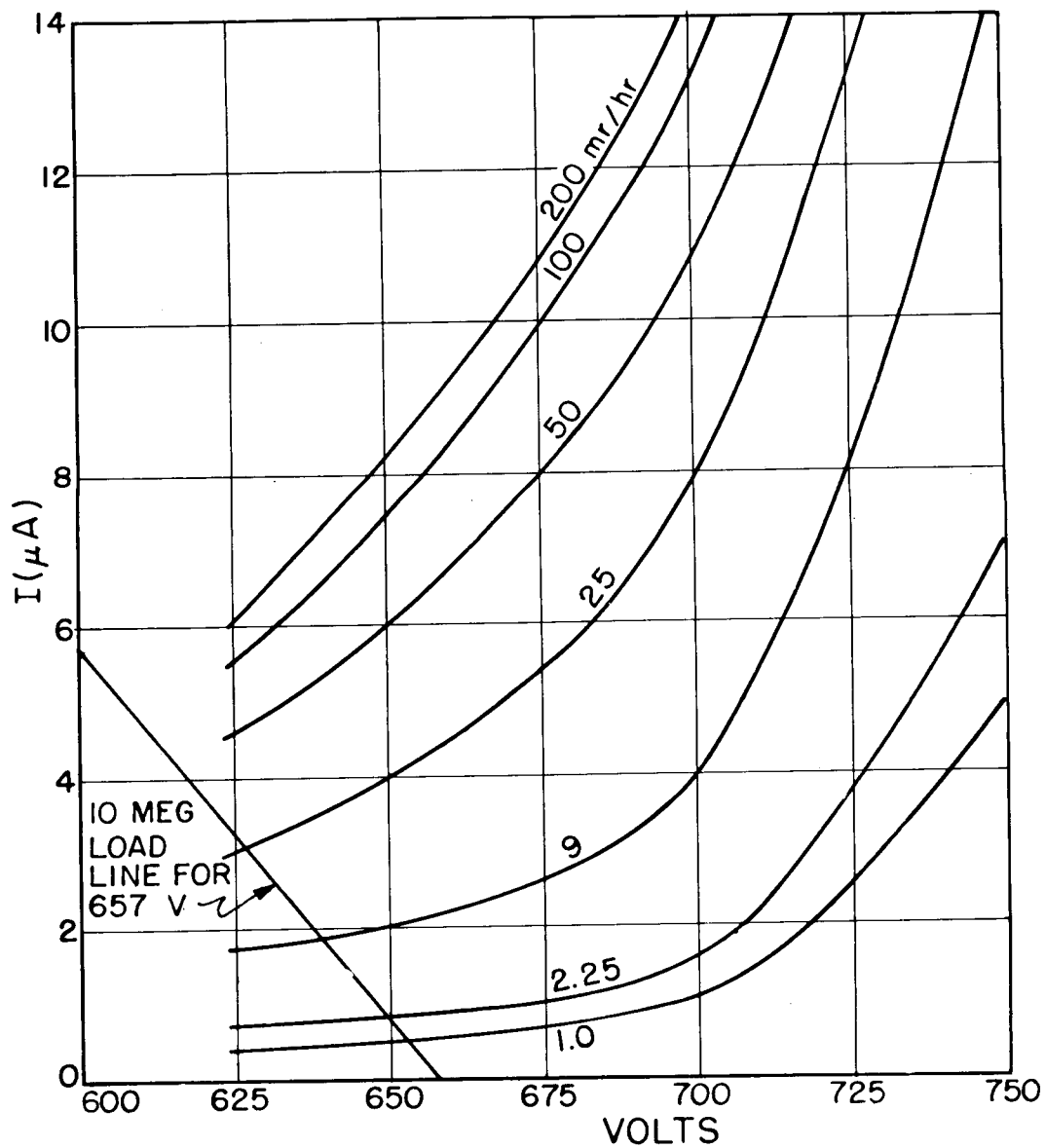

Fig. 25—Voltage-current characteristic of BS-1 counter tube (Anton).

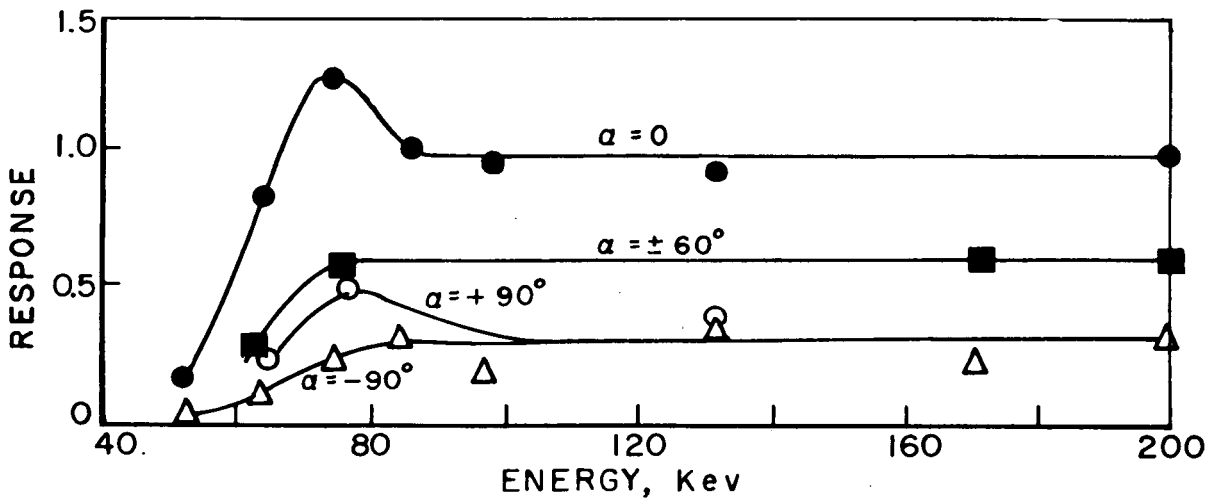
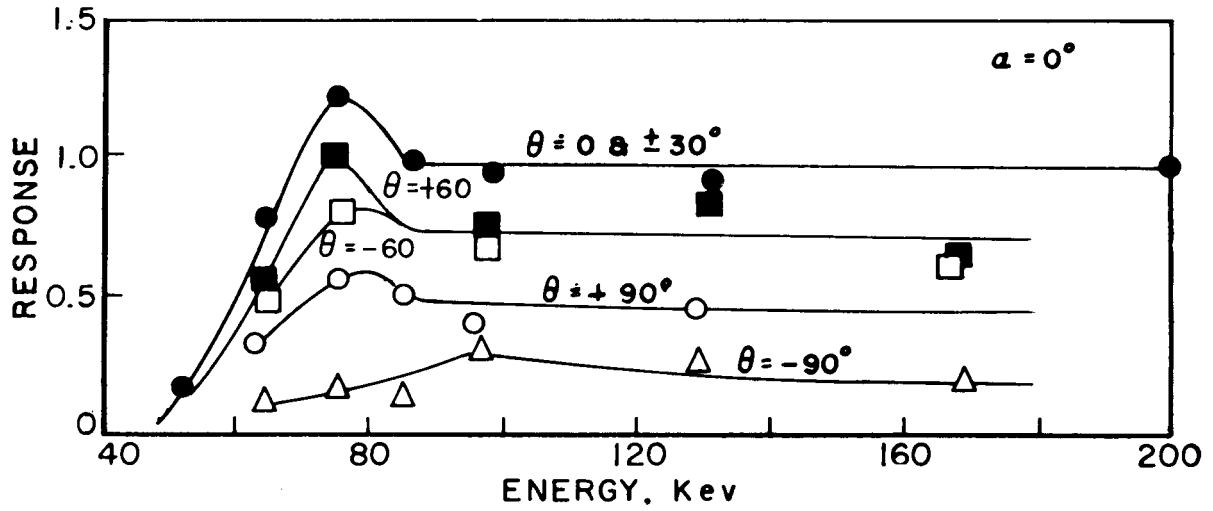
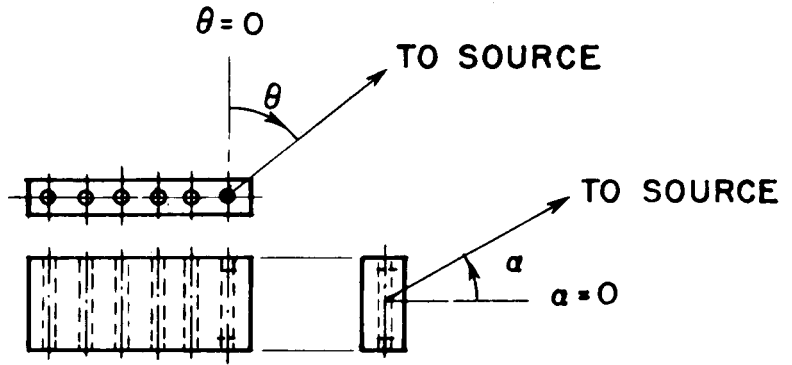

Fig. 26—Energy and directional response of LR detectors to gamma radiation.

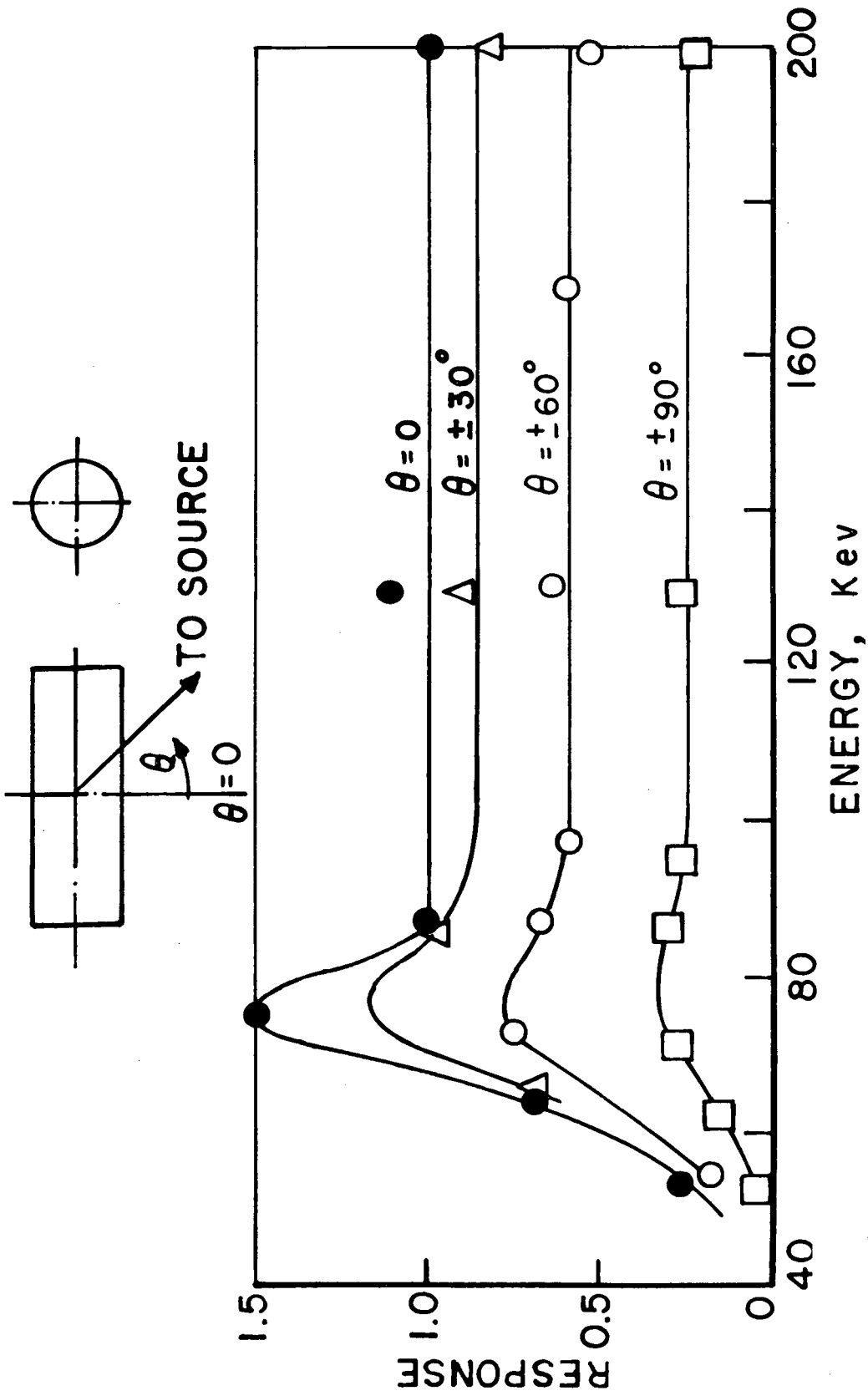

Fig. 27—Energy and directional response of VLR detectors to gamma radiation.

204  
078

## Appendix I

# STATION EQUIPMENT—LINE TERMINATING FOR REMOTE RADIATION MEASUREMENTS

AMERICAN TELEPHONE AND TELEGRAPH COMPANY

195 BROADWAY, NEW YORK 7, N. Y.

EXCHANGE 3-9800

C. M. MAPES  
ASSISTANT CHIEF ENGINEER

June 7, 1955

The Atomic Energy Commission has tested, during the recent atomic test series in Nevada, telemetering equipment developed for them by the National Bureau of Standards which permits the measurement of radiation levels remotely. The A.E.C. may be asking the Telephone Companies to furnish non-published individual business or P.B.X. station lines equipped with line terminating (unattended station) equipment for use with the apparatus developed by the Bureau of Standards.

We understand that the Federal Civil Defense Administration has expressed an active interest in this arrangement and has discussed with the National Bureau of Standards the possibility of developing similar arrangements for Civil Defense use. We have been assured that any equipment developed for Civil Defense use will also be arranged to use Telephone Company unattended station equipment.

Basically, the A.E.C. remote data station now in use is a telemetering transmitter which is connected through the line terminating equipment (remote station) to the telephone line. The line terminating equipment which is shown on the attached drawing is assembled and wired locally. In operation, an attendant at a control point places a telephone call to the remote unattended station. The remote equipment trips the ring and begins transmitting a series of 10-second bursts of tone. Some of these tones are for calibration purposes and the remainder indicate, by variations of their pitch, the reading of an associated radiation intensity meter. Frequency measurements made at the calling point determine the radiation intensity at the remote point. After its two-minute cycle is completed the remote equipment disconnects itself and the operator receives normal disconnect supervision.

Referring to Fig. 1 (Line Terminating Equipment - Remote Station) its operation may be described as follows. When the remote station is called, 20-cycle ringing current will pass through the 1 mfd capacitor (A) and an 8A thermistor (B) to operate relay (C). This in turn will cause the operation of relay (D) through normal contacts on relay (E). Relay (D) in operating will: (1) lock operated through its own contact (2) connect the inductor (F) across the line to produce an off-hook condition (3) supply 7-1/2 volts to energize the oscillator sequence system.

A sequence of operation then follows to calibrate the telemetering system and then to send tones back to the control station whose frequency is determined by the measured radiation level. All tones are within the range from 700 to 1400 cycles per second. As a final step in the operating sequence 7-1/2 volts is applied momentarily to relay (E) to operate

[Editor's Note: Figures 1 and 2 referred to in this Appendix are Figs. 22 and 23 in Appendix A.]

it and release relay (D). This removes inductor (F) from the line to restore the on-hook condition and removes 7-1/2 volts from the oscillator sequence system. Relay (E) then releases when 7-1/2 volts is removed from its windings and all apparatus is normal.

Referring to Fig. 2 (Line Terminating Equipment - Control Station) its operation may be described as follows. When the apparatus is assembled and wired as shown and the key is in its normal position, the regular station set only is connected to the line. When the key is in the operate position, the inductor (1533K) is connected across the line and contacts 3 and 8 are energized. The inductor provides an off-hook condition so the station handset may be replaced to reduce sidetone while frequency measurements are being made. Contacts 3 and 8 bridge the A.E.C.'s amplifier, band pass filters, isolating transformers and frequency measuring equipment across the line. Contacts 9 and 10 may be connected to a pilot light in the A.E.C.'s equipment which serves to indicate that a call is in process on the remote indicating equipment even though the handset is on the hook.

The arrangements as described above should function either directly on a subscriber's line or through a P.B.X. Precautions should be taken to see that levels do not exceed the maximum allowable over Bell System lines. Where a telephone instrument is to be provided it may be bridged across the line with its ringer disconnected.

At the request of Mr. Greber and Mr. Hanselman, copies of this letter are included for General Plant and Commercial Managers. Mr. Hanselman will write to the General Commercial Managers regarding the commercial aspects of this matter. Copies are also being sent, at Mr. Armstrong's request, to all Defense and Military Coordinators.

Yours very truly,

*C. M. Maper*

Assistant Chief Engineer

**Appendix B**

**PROJECT 39.9 MAINTENANCE REPORT**





# PROJECT 39.9 MAINTENANCE REPORT

by

Donald G. Ludlum  
Reynolds Electrical & Engineering Co., Inc.

## PURPOSE AND BACKGROUND

The purpose of Project 39.9 was to measure fallout from various tests during Operation Plumbbob. Project manager was Sanford C. Sigoloff, a consultant to the Division of Biology and Medicine, AEC. The program was sponsored by the Civil Effects Test Group.

Fallout measurements were made with equipment designed by Louis Costrell, W. Pearlman, and H. O. Cline of the National Bureau of Standards. The equipment will be referred to as RDS-1A units and consisted of an ion chamber type detector with a system to convert the ion chamber output to a frequency shift. Information from the RDS-1A units was transmitted over commercial telephone lines and consisted of oscillator calibration points and detector radiation level.

CETG requested Reynolds Electrical & Engineering to interview the technicians that were assigned to the project and find what maintenance was done on the RDS-1A units and, from the maintenance man's view point, how the system could be improved.

Technicians associated with 39.9 were:

Employee	Now Employed at
Robert J. Stadlander	UCRL, H&N Operation, Livermore
Charles Amandon	UCRL, H&N Operation, Livermore
Donald Stewart	Unknown
William Dawson	REECO, Nevada Test Site

Of the technicians, Stadlander was generally in charge of the maintenance and installation during the majority of the operation.

## OPERATION OF THE UNIT

The RDS-1A units were installed at both on-site and off-site locations. As the environmental and handling conditions were so varied from on-site to off-site, the comments will be broken down into two parts.

### OFF-SITE INSTALLATION, MAINTENANCE, AND OPERATION

Off-site installation went quite smoothly. The units were normally installed on the roofs of the local telephone buildings. Check-out procedure was occasionally complicated by lack of power for the test equipment, requiring the check out to be performed at places other than the final installation point. In one case, the check out had to be made in an adjoining town.

No problems resulted from the check out procedure.

Off-site maintenance consisted of replacing the unit as a whole at the installation. The units were not repaired at the time of replacement.

In one case, the installation had to be moved from Death Valley Junction, Calif., to Lone Pine, Calif. Line noise and frequent outage rendered the unit useless at Death Valley Junction.

Operation of off-site units was normally without problem. The oscillator gave the appearance of temperature dependence in that the calibration check frequencies would vary through the day. Data could still be used by extrapolating new conversion curves from the check frequencies.

Occasionally, reliable data could not be obtained from the off-site locations owing to noise from the telephone circuits, but this could usually be cleared up by rerouting the challenge call.

A second form of line problem was very short term line transients, generally attributed to operator busy check monitoring. This would cause erratic count in any of the check-out and reading modes. As a result, the call would have to be placed a second or third time to challenge the unit.

### ON-SITE OPERATIONS

On-site operations had the purpose of measuring fallout at various distances from Ground Zero. Installation was in standard blast cans. Communication was by field wire to the Bell cable stations and then on to the read-out station which was normally at CP-2.

The RDS-1A units were handled and operated much more frequently on-site than off-site, and some maintenance problems developed.

It was found that the on-site units would develop a drift in calibration frequency with usage. This drift was attributed to the 1.5-volt battery and old tubes. Replacing 1.5-volt batteries and the full tube compliment, the units would maintain calibration through the test. A shortage of CK5971 tubes developed; so the procedure of maintenance was to recalibrate the units until the change in tube characteristic would put the oscillator out of the calibration range. Tube aging was evident in all stages; however, the cathode follower and oscillator stages were the only ones that would affect the calibration capabilities. This

procedure was used in the units that did not get a new tube compliment. Toward the end of the operation, some units were "cannibalized" for parts (particularly tubes) to keep the majority of the units in operation.

Other failures of electrical nature were output transformers shorting in two units, and stepping switch failures in a "few" units. Battery failure occurred in one unit (open), but no other battery problems developed. Fresh 1.5-volt batteries would sometimes be used to bring "old tube" units back up to the calibration range.

No cause of the output transformer failure was found.

Stepping switch problems were a result of the motor losing its torque capabilities. This problem would show up in an abnormally long read-out time. The motors were not opened, but the technicians thought that the motors became dust filled and bogged down.

Two mechanical problems developed during on-site operation. The CK5971 tubes would vibrate out of their sockets during delivery to the test site location and, sometimes, during the blast. The friction catch of the high-voltage lead (inside the unit at the front cover) would disconnect during transportation and during the blast. Some data were lost owing to the above mechanical failures during the blast.

To overcome the problems, the technicians used electrical tape to hold down the tubes and high-voltage lead.

#### GENERAL TECHNICIAN COMMENTS ON THE RDS-1A UNITS

The following proposals were made by the technicians to simplify maintenance, installation, and operation.

1. A portable self-powered frequency meter should be made available for installation checks of the unit. This would greatly simplify the installation of the units where power is not available.

2. A challenge circuit should be provided at the read-out station to simplify getting data from off-site locations. This would eliminate the necessity of placing more than one call to a station when line transients are encountered or data are doubtful.

3. Hold downs for the tubes should be incorporated. All wiring should have positive type connections (such as the front panel H.V. wire). Plug-in modular construction of the various electrical subassemblies was highly desirable to simplify installation point service. Calibration control at the front panel was felt necessary, especially, for test site installation where rough mechanical usage was encountered.

4. For on-site use, the instrument weight was very objectionable. If the instrument weight could be lowered, the unit would be subjected to much less mechanical abuse from simpler handling procedure. It was suggested that the battery pack be housed in a separate package with good cable interconnections of a least 6 ft. This would greatly simplify blast-can installations.

5. It was felt that the RDS-1A units needed complete reconditioning before they can be used in another operation. This would include complete tube compliment and stepper switch cleaning.

The units are presently located in a storage container at the Bureau of Standards, Washington, D. C. They will be moved in the near future to the Germantown Operation Area, AEC, Washington, D. C. Robert Darneal, Radiation Instrument Branch, AEC, Washington, D. C., Ext. 5355, has knowledge of storage of the units.

RDS-1A units were installed at the following off-site communities:

Arizona

1. Kingman

California

2. Baker
3. Barstow
4. Death Valley Junction
5. Lone Pine

Nevada

6. Alamo
7. Austin
8. Carson City
9. Elko
10. Ely
11. Eureka
12. Hawthorne
13. Henderson
14. Logandale
15. Pioche

Nevada

16. Reno
17. Tonopah
18. Wells
19. Winnemucca

Utah

20. Beaver
21. Cedar City
22. Delta
23. Eureka
24. Kanab
25. Manti
26. Mt. Pleasant
27. Parowan
28. Provo
29. Richfield
30. Salt Lake City
31. St. George