

NACA RM E53K20

~~CONFIDENTIAL~~

CLASSIFICATION CHANGED
UNCLASSIFIED



By Authority of 107136 Date 12/5/70

RESEARCH MEMORANDUM

Declassified by authority of NASA
Classification Change Notices No. 212
Dated ** 1971

INVESTIGATION OF THREE LOW-TEMPERATURE-RATIO COMBUSTOR
CONFIGURATIONS IN A 48-INCH-DIAMETER RAM-JET ENGINE

By Carl L. Meyer and Henry J. Weina

Lewis Flight Propulsion Laboratory
Cleveland, Ohio

FACILITY FORM 602	<u>N71-70503</u> (ACCESSION NUMBER)	(THRU)
	<u>41</u> (PAGES)	<u>None</u> (CODE)
	<u>1</u> (NASA CR OR TMX OR AD NUMBER)	(CATEGORY)

NATIONAL ADVISORY COMMITTEE FOR AERONAUTICS

WASHINGTON
March 10, 1954

~~CONFIDENTIAL~~

NATIONAL ADVISORY COMMITTEE FOR AERONAUTICS

RESEARCH MEMORANDUMINVESTIGATION OF THREE LOW-TEMPERATURE-RATIO COMBUSTOR CONFIGURATIONS
IN A 48-INCH-DIAMETER RAM-JET ENGINE

By Carl L. Meyer and Henry J. Welna

SUMMARY

A preliminary evaluation was made of three types of combustor configuration in a 48-inch-diameter ram-jet engine in order to select the one with the greatest promise of efficient and stable combustion at low fuel-air ratios and low combustor-inlet pressures. The combustor configurations evaluated include (1) a can-piloted configuration using a gutter-type flame holder with can-type pilot burners for stability, (2) an annular-piloted configuration using a gutter-type flame holder with an annular pilot burner to provide stability and to serve as a flow divider for confined fuel-air mixing, and (3) a can-type configuration using a flow divider for confined fuel-air mixing. No modifications were made to optimize the performance of any configuration.

On the basis of this preliminary evaluation at an inlet-air temperature of about 990° R, the annular-piloted combustor configuration gave the greatest promise of providing combustion efficiencies and combustor total-pressure ratios in excess of 0.90 at low fuel-air ratios with combustor-inlet pressures as low as 700 pounds per square foot absolute. At a combustor-inlet total pressure of approximately 1200 pounds per square foot absolute, the combustion efficiency of this configuration reached a maximum of about 0.90 at a fuel-air ratio of 0.025 and was higher than that of the other configurations at all fuel-air ratios investigated below about 0.040. This combustion efficiency was not greatly affected by a reduction in combustor-inlet pressure to about 800 pounds per square foot absolute. The combustor total-pressure ratios were not appreciably different for the three configurations, being about 0.905 ± 0.01 at a fuel-air ratio of 0.035, the annular-piloted configuration having the highest pressure ratio.

INTRODUCTION

As part of a general research program on ram-jet combustors, an investigation is being conducted at the NACA Lewis laboratory to

evaluate various ram-jet combustor designs and thus to determine design criteria that will permit efficient and stable combustion at combustor flow conditions representative of those during the cruise phase of the flight plan of a long-range missile. The performance objectives of the investigation include the attainment of combustion efficiencies and combustor total-pressure ratios above 0.90 at the following operating conditions with grade JP-1 fuel: (1) fuel-air ratios between 0.03 and 0.04 (design point, 0.035), (2) combustor-inlet pressures as low as $1/3$ atmosphere, (3) combustor-inlet Mach number of about 0.14, and (4) combustor-inlet temperature of about 990° R.

A previous investigation of ram-jet combustors having typical gutter-type flame holders and operating at combustor-inlet pressures on the order of $1/2$ atmosphere and less indicates that the use of a stable heat source or pilot flame improves the stability limits (ref. 1). Therefore, an initial phase of the investigation was an experimental study of some of the design features of can-type pilot burners (ref. 2). Consideration of the combustion-efficiency and fuel-air-ratio objectives, together with the results of other investigations, leads to the conclusion that it is advantageous to confine the injected fuel to a portion of the combustor air in such a way that an optimum fuel-air ratio is maintained for mainstream combustion. The use of such a method is reported in references 3 and 4, which show that large gains in combustion efficiency at low fuel-air ratios can be obtained by properly controlling the fuel-air mixing process. This method has also been used to improve the low-fuel-air-ratio combustion efficiencies of ram-jet combustors required to operate over a wide range of combustor temperature ratios (refs. 5 to 8). As a second phase of the investigation, an experimental evaluation (reported in ref. 9) was made of a rectangular segment of an annular-piloted combustor with baffle-type flame holder that incorporated the features of confined fuel-air mixing and a high-air-flow stable pilot burner.

Following these initial phases of the investigation, a preliminary evaluation was made of three types of low-temperature-ratio combustor configurations in a 48-inch-diameter ram-jet engine and is reported herein. The combustor configurations selected for investigation include: (1) can-piloted, (2) annular-piloted, and (3) can-type configurations. The can-piloted combustor configuration incorporated a gutter-type flame holder with six can-type pilot burners to provide stability; the design of the pilot burners was based on the results of reference 2. The design of the annular-piloted combustor configuration was based on the results of reference 9 and is described therein; the annular pilot burner served both as a flow divider that permitted confined fuel-air mixing and as a continuous source of ignition and thus stability for a gutter-type flame holder. The can-type combustor configuration incorporated a flow divider for confined fuel-air mixing. One of each type of combustor configuration was investigated;

no modifications were made to optimize the performance of any configuration. This preliminary evaluation was intended to indicate the most promising configuration for the previously stated performance objectives.

The investigation was conducted in a direct-connect installation in an altitude chamber over a limited range of fuel-air ratio at combustor-inlet total pressures from about 700 to 1300 pounds per square foot absolute with an inlet-air temperature of about 990° R. This inlet-air temperature corresponds to the standard total temperature at a flight Mach number of 2.75 for altitudes above the tropopause.

APPARATUS

Installation

A schematic diagram of the direct-connect installation of the ram-jet engine in an altitude chamber of the NACA Lewis propulsion systems laboratory is shown in figure 1. Inlet air entered the chamber and passed through angle-iron blockage and smoothing screens before entering the engine through a bellmouth inlet. A bulkhead and a labyrinth seal prevented leakage of inlet air into the test section. The hot gases from the engine passed into the exhaust section through an extension that prevented recirculation of the hot exhaust gases into the test section. The combustion was observed through a periscope directly behind the engine.

Engine

A schematic drawing of the 48-inch-diameter ram-jet engine is shown in figure 2. The engine station numbers indicate the number of inches from the engine inlet, which is designated station 0. The engine-inlet diffuser was a cone with an included angle of 30°. The 48-inch-diameter combustion chamber extended from the diffuser outlet (station 30.6) to the exhaust-nozzle inlet (station 89.5) and was water-jacketed from station 40.6 to station 89.5. Affixed to the exit of the combustor was a 19-inch-long convergent water-jacketed exhaust nozzle with a cylindrical throat 6 inches long and 32.75 inches in diameter.

Details of the instrumentation used to measure pressures and temperatures at the various stations are also shown in figure 2.

Combustor Configurations

The three types of combustor configuration investigated are described in the following paragraphs.

Can-piloted configuration. - The can-piloted combustor configuration used a conventional baffle- or gutter-type flame holder into which six can-type pilot burners were incorporated as continuous sources of ignition to provide stable combustion.

A schematic diagram and photographs of the can-piloted combustor configuration are presented in figures 3(a) to (c). An 8-inch-diameter can-type pilot burner was located in the center, and five 5-inch-diameter can-type pilot burners were equally spaced in a circle with a mean diameter of 21 inches. An annular gutter interconnected the five outer pilot burners; ten sloping radial gutters connected the center pilot burner with the outer pilot burners and their interconnecting annular gutter. An outer annular gutter, which had a mean diameter of 35.5 inches, was connected with the outer pilot burners and their interconnecting annular gutter by 15 sloping radial gutters. Fifteen 3-inch-long radial stub gutters extended from the outer edge of the outer annular gutter. All gutters were 2 inches wide at the downstream edge. The projected area of the can-piloted combustor configuration was about 43 percent of the combustor cross-sectional area.

Details of the pilot-burner cans, the design of which was based on the results of reference 2, are given in figure 3(d). The surface open area of each pilot-burner can was about 125 percent of its discharge cross-sectional area.

Two fuel systems were used in the can-piloted combustor configuration, one supplying fuel for the pilot burners and the other for mainstream combustion (fig. 3(a)). The center and outer pilot burners were each fitted with single fuel-spray nozzles rated at about 80 and 40 gallons per hour, respectively, at a differential pressure of 100 pounds per square inch.

Fuel for mainstream combustion was injected at two locations well upstream of the flame holder to aid vaporization and mixing (fig. 3(a)). A 21-inch-diameter ring, fitted with 26 fuel-spray nozzles installed to spray in the downstream direction, was located about 14 inches upstream of station 0. In addition, six sets of radially adjustable fuel-spray bars were located about 18 inches upstream of station 0; each set of fuel bars included an inner and outer bar fitted, respectively, with 2 and 3 circumferentially spaced fuel-spray nozzles installed to spray in the upstream direction. The radial position of the inner and outer fuel-spray bars could be altered independently to vary fuel distribution. All fuel-spray nozzles of the mainstream fuel-injection system were of the variable-area type and were rated at about 35 gallons per hour at a differential pressure of 100 pounds per square inch.

CONFIDENTIAL

Annular-piloted configuration. - The annular-piloted combustor configuration used a baffle- or gutter-type flame holder with a large annular pilot burner as a continuous source of ignition to provide stable combustion. The large annular pilot burner was designed to permit higher pilot-burner air flow, together with more uniformly distributed pilot flame, than in the case of the six can-type pilot burners of the previous configuration. The annular-piloted configuration is shown in figure 4. The gutter-type flame holder was placed in the center of the combustor downstream of the pilot region to receive beneficial stabilization from the pilot flame. The annular pilot burner also served as a flow divider. Mainstream fuel injection, and thus mainstream combustion, was confined to that portion of the combustion-chamber air that passed through the circular flow area formed by the pilot; dimensions were selected so that mainstream combustion would occur at an approximately stoichiometric fuel-air ratio at a low over-all fuel-air ratio.

3111

The design of the annular-piloted combustor configuration was based on the results of reference 9 and is described therein. In cross section, the shape of the annular pilot burner (fig. 4) was that of an asymmetric V. The outer surface was perforated by four rows of 1/2-inch-diameter holes; the surface was carried downstream of these holes to act as a flow divider and to provide a protected combustion zone. The inner surface of the pilot burner was cut longitudinally, and the cuts were spread at the downstream end by forming the metal into V-shape; the resulting openings provided additional air entry for pilot combustion and permitted a gradual mixing of the mainstream fuel-air mixture with the pilot combustion process. Eight slanted radial V-gutters were attached to the trailing edge of the inner surface of the annular pilot burner and were joined at their trailing edges by an annular gutter with a mean diameter of 8 inches; these slanted radial gutters and the small annular gutter formed additional flame seats for mainstream combustion.

Two fuel systems were used (fig. 4(a)), one supplying fuel for the annular pilot burner and the other for mainstream combustion. The annular pilot burner was fitted with 32 fuel-spray nozzles rated at 5 gallons per hour at a differential pressure of 100 pounds per square inch. Fuel for mainstream combustion was injected well upstream of the exit of the annular pilot burner to aid vaporization and mixing. The mainstream fuel-injection system included 10- and 18-inch-diameter fuel rings fitted with 8 and 18 fuel-spray nozzles, respectively, installed to spray in the downstream direction; the fuel rings were located just downstream of engine station 0. The mainstream fuel-spray nozzles were rated at 40 gallons per hour at a differential pressure of 100 pounds per square inch.

CONFIDENTIAL

Can-type configuration. - The maximum piloting is obtained by a configuration in which all of the fuel is burned in the pilot burner; the can-type combustor may be considered such a configuration. A schematic diagram and photographs of the can-type combustor configuration used in the present investigation are presented in figure 5. Details of the can are given in figure 5(a); the surface open area of the can was about 115 percent of the combustor cross-sectional area. A flow divider (or control sleeve) was used to confine the injected fuel to a portion of the combustion-chamber air so as to achieve an approximately stoichiometric fuel-air ratio for mainstream combustion at a low overall fuel-air ratio; the flow divider also permitted use of an existing fuel-injection system.

A single fuel-spray nozzle, rated at 40 gallons per hour at a differential pressure of 100 pounds per square inch, was located in the dome of the can. Mainstream fuel was injected well upstream of the can to aid vaporization and mixing. The mainstream fuel-injection system consisted of the fuel ring and fuel-spray bars used with the can-piloted combustor configuration; all mainstream fuel nozzles sprayed in the upstream direction.

PROCEDURE

Test Conditions

The investigation reported herein was conducted at an inlet-air total temperature of approximately 990° R, which corresponds to the standard temperature at a flight Mach number of 2.75 for altitudes above the tropopause. Gas-fired indirect heaters were used to raise the temperature of the inlet air, so that the air was not contaminated in the heating process.

A choked throttling valve in the inlet-air line was used to set selected air flows; therefore, air flow was independent of engine operating conditions. The pressure into which the engine exhausted was maintained at a value below that required to choke the engine exhaust nozzle for engine operation with mainstream burning; thus flow conditions in the engine were independent of the facility exhaust pressure.

Data were obtained at air flows of approximately 40 and 60 pounds per second and over a range of fuel-air ratio from about 0.020 to 0.045 at each air flow. At a given engine-inlet air flow, the combustor-inlet total pressure varied with exhaust-gas temperature (fuel-air ratio); the combustor-inlet total-pressure range was from about 700 to 900 and 1000 to 1300 pounds per square foot absolute at air flows of about 40 and 60 pounds per second, respectively.

Initiation of Combustion

Before ignition of the combustor, the desired air flow was set by means of the choked throttling valve in the inlet-air line and the exhaust pressure was adjusted to provide a combustor-inlet Mach number of approximately 0.15. The pilots, pilot, or piloting region was then ignited. After pilot combustion was stabilized, mainstream fuel was introduced and the fuel flow was increased until stable combustion was obtained; the exhaust pressure was reduced simultaneously as mainstream fuel flow was increased until the exhaust nozzle was choked.

T111

Fuel Flow

For the can-piloted combustor configuration, the fuel flows to the can-type pilot burners, fuel ring, and adjustable bars were independently controlled. For the annular-piloted combustor configuration, the fuel flows to the annular pilot burner and to each of the two fuel rings were independently controlled. Control of fuel flow for the can-type combustor configuration was accomplished in a manner similar to that for the can-piloted configuration. For the can-piloted and annular-piloted combustor configurations, independent control was used to permit pilot fuel-flow variations from 0 to as high as 20 percent of the total fuel flow.

In general, the fuel temperature was about 640° R; however, most of the data for the annular-piloted combustor configuration were obtained with fuel heated to about 750° R. The fuel used throughout the investigation conformed to specification MIL-F-5616, grade JP-1, with a lower heating value of 18,600 Btu per pound and a hydrogen-carbon ratio of 0.162.

Methods of Calculation

The symbols and methods of calculation are given in appendixes A and B, respectively. Air flow was calculated from pressures and temperatures measured at station 2 (fig. 2). Exhaust-gas temperature was calculated with the gas flow, total pressure measured at the exhaust nozzle, and a flow continuity expression that assumed a choked exhaust nozzle. Combustion efficiency was calculated as the ratio of actual to theoretical enthalpy rise. The net thrust coefficient was based on the combustor cross-sectional area.

RESULTS AND DISCUSSION

Inlet Conditions

In order to define the combustor environment of the present investigation, typical inlet total-pressure profiles, together with the variation of average combustor-inlet total pressure and Mach number with fuel-air ratio, are presented in figure 6 for the three configurations investigated. Radial and circumferential inlet total-pressure distributions (fig. 6(a)), in general, were uniform. At a given air flow, the combustor-inlet total pressure (fig. 6(b)) increased, and the combustor-inlet Mach number (fig. 6(c)) decreased as fuel-air ratio was raised. The inlet total pressure varied from about 1020 to 1320 pounds per square foot absolute at an air flow of 60 pounds per second and from about 700 to 880 pounds per square foot absolute at an air flow of 40 pounds per second within the range of the present investigation. Combustor-inlet Mach number varied from about 0.16 to 0.13 within the range of fuel-air ratio investigated; this Mach number range corresponds to velocities from about 245 to 200 feet per second at the inlet temperature of 990° R.

Performance

Combustion efficiency. - The variation of combustion efficiency with fuel-air ratio is presented in figure 7(a) for the three combustor configurations investigated. The combustion efficiency of the can-piloted combustor configuration varied from about 0.70 to 0.80 and, in general, increased as fuel-air ratio was raised within the range of fuel-air ratio and fuel distribution investigated; maximum combustion efficiency would have been obtained, therefore, at a fuel-air ratio beyond the range of interest in the present investigation. With a given fuel-injection system, the data obtained at air flows of about 40 and 60 pounds per second indicate that combustion efficiency was not appreciably affected by combustor-inlet pressure (fig 6(b)) within the range investigated. At a fuel-air ratio of about 0.034, there was a trend of increased combustion efficiency with decreased pilot fuel flow.

The combustion efficiency of the annular-piloted combustor configuration reached a maximum of about 0.90 at a fuel-air ratio of 0.025, decreased to about 0.65 at a fuel-air ratio of 0.045, and was not appreciably affected by combustor-inlet pressure (fig. 6(b)) within the range investigated. Most of the data were obtained with heated fuel (about 750° F); however, data obtained at a fuel-air ratio of 0.035 with unheated fuel (about 640° R) indicate that fuel temperature had essentially no effect on combustion efficiency within the range investigated. Combustion efficiency was also essentially unaffected by variations in pilot fuel flow within this range at a fuel-air ratio of about 0.035.

3111

The combustion efficiency of the can-type combustor configuration reached a maximum of about 0.78 at a fuel-air ratio of 0.035 and decreased to about 0.70 at fuel-air ratios of about 0.028 and 0.044. Data were obtained only at an air flow of approximately 60 pounds per second. Visual observation of the combustion by means of the periscope indicated there were six regions of flame within the can in line with the fuel-spray bars, which may be indicative of nonuniform circumferential fuel distribution.

The combustion efficiency of the annular-piloted combustor configuration was higher than that of the other configurations at fuel-air ratios below about 0.04. The maximum combustion efficiency of the annular-piloted configuration was of approximately the desired level (0.90) but at a fuel-air ratio below that which was considered as the design-point fuel-air ratio (0.035) in the present investigation. The maximum combustion efficiency of the can-type combustor configuration was obtained at the design-point fuel-air ratio but was lower than desired. The combustion efficiency of the can-piloted combustor increased as fuel-air ratio was raised within the range investigated, was lower than that of the other configurations at the design-point fuel-air ratio of the present investigation, and was higher than that of the other configurations at fuel-air ratios above about 0.04.

Combustor total-temperature ratio. - The variations of combustor total-temperature ratio with fuel-air ratio are presented in figure 7(b) for the three combustor configurations. In general, the trends of temperature ratio with fuel-air ratio reflected the trends of combustion efficiency with fuel-air ratio.

The combustor total-temperature ratio obtained with the can-piloted combustor configuration increased continuously as fuel-air ratio was raised, as did combustion efficiency, within the range investigated. The temperature ratio of the annular-piloted configuration was a maximum at a fuel-air ratio of about 0.038, and that of the can-type combustor configuration appeared near a maximum at a fuel-air ratio of 0.046; that the temperature ratio reached a maximum value, within the fuel-air-ratio range investigated, was due to the trend of decreased combustion efficiency. The temperature ratio of the annular-piloted combustor configuration was higher than that of the other configurations at fuel-air ratios below about 0.038; at richer fuel-air ratios, the can-piloted combustor permitted higher temperature ratios than the other configurations.

Combustor total-pressure ratio. - The variation of combustor total-pressure ratio with fuel-air ratio is presented in figure 7(c) for the three combustor configurations. The total-pressure ratio varied only slightly with fuel-air ratio and was not appreciably different for the three configurations.

Net thrust coefficient. - In providing thrust, combustion efficiency (or combustor total-temperature ratio) and combustor total-pressure ratio are both important factors and should be high for a given fuel-air ratio. The effects of these factors are combined in the net thrust coefficient, the variation of which with fuel-air ratio is presented in figure 7(d) for the three combustor configurations (flight Mach number, 2.75). Inasmuch as combustor-inlet pressure, pilot fuel flow, and fuel temperature did not have appreciable effects on combustion efficiency and, therefore, would not appreciably affect the net thrust coefficient, these variables are not identified in the figure; all data are shown for each configuration, and a portion of the data scatter is attributed to the aforementioned variables. The dashed curve shows the theoretical maximum net thrust coefficient that would be obtained with a combustion efficiency of 1.0, a combustor total-pressure ratio of 1.0, and the exhaust-nozzle velocity and flow coefficients used for the actual data.

For the three combustor configurations investigated, the trend of net thrust coefficient with fuel-air ratio reflects primarily the trend of combustion efficiency with fuel-air ratio, inasmuch as the combustor total-pressure ratios were not appreciably different. The net thrust coefficient of the can-piloted combustor configuration increased continuously as fuel-air ratio was raised within the limits investigated, as did combustion efficiency; that of the annular-piloted combustor configuration reached a maximum value at a fuel-air ratio of about 0.04 and decreased as fuel-air ratio was further raised because of reduced combustion efficiency; and that of the can-type combustor configuration was approaching a maximum value at the highest fuel-air ratio investigated because of the trend of decreased combustion efficiency at high fuel-air ratios. The annular-piloted combustor configuration had the highest net thrust coefficient of the configurations investigated at fuel-air ratios below about 0.041; at richer fuel-air ratios, the can-piloted configuration had the highest net thrust coefficient of the three configurations.

Comparison of Configurations

The performance of the three combustor configurations, evaluated in the present investigation, is compared in the following table at the design-point fuel-air ratio of 0.035:

Combustor configuration	Combustion efficiency, η	Total-temperature ratio, T_6/T_2	Total-pressure ratio, P_6/P_2	Net thrust coefficient, $F_n/A_b q_0$
Annular-piloted	0.83	2.78	0.915	0.53
Can-type	.78	2.66	.895	.49
Can-piloted	.74	2.62	.905	.45

The best performance characteristics at the design-point fuel-air ratio and the highest combustion efficiency within the range of fuel-air ratio investigated were obtained with the annular-piloted combustor configuration. The maximum combustion efficiency of this configuration was approximately 0.90 at a fuel-air ratio of about 0.025. Of the three combustor configurations investigated, the annular-piloted combustor configuration, therefore, appears to have the most promise of attaining the desired combustion efficiency at the design-point conditions.

One of the major differences that exist among the three combustor configurations investigated is the method of controlling fuel distribution. In the annular-piloted and can-type combustor configurations, the mainstream fuel was confined mechanically to a portion of the combustor air to achieve an approximately optimum fuel-air ratio for mainstream combustion at low over-all fuel-air ratio. In the can-piloted combustor configuration, the radial position of the mainstream fuel-injection system was controlled in an attempt to establish optimum local fuel-air ratios for mainstream combustion without mechanical means of confining the fuel to a portion of the combustor air. Maximum combustion efficiency was obtained at low over-all fuel-air ratio with the annular-piloted and can-type combustor configurations; whereas, the optimum fuel-air ratio for maximum combustion efficiency of the can-piloted combustor configuration was above the limits of interest in the present investigation. The results indicate the importance of mechanically confining the mainstream fuel to a portion of the combustor air in order to obtain maximum combustion efficiency at low over-all fuel-air ratio. The use of flow dividers as a means of fuel-air mixture control to improve low-fuel-air-ratio performance has been reported in references 3 to 8.

The major differences, other than fuel system, that exist among the three combustor configurations are the design and arrangement of the flame holders and the available burning length. Gutter-type flame holders were used in the can-piloted and annular-piloted combustor configurations. The can-piloted combustor configuration used conventional annular V-gutters with interconnecting sloped radial V-gutters.

CONFIDENTIAL

In the annular-piloted combustor configuration, sloping radial V-gutters were used both as the inner surface of the annulus and downstream of the annulus to permit gradual mixing of the mainstream fuel-air mixture with the combustion process. Combustion within the annulus was protected by the outer surface and took place in a zone of expanding volume that provided low flow velocity and thereby permitted combustion to be completed in a relatively short length. The investigation of reference 8 indicated somewhat higher combustion efficiency at low fuel-air ratio for a configuration that used sloping-channel gutters with a protected combustion region than for one using conventional annular V-gutters. Since the available burning length (figs. 3(a) and 4(a)) was not appreciably different for the can-piloted and annular-piloted combustor configurations, the performance differences between these two configurations are attributed to the method of controlling fuel distribution and to the design and arrangement of the flame-holding system.

The can-type combustor configuration used a conventional can-type flame holder. The available burning length for this configuration (fig. 5(a)) was shorter than that for the other two combustor configurations, as would be expected for installations in a given over-all length. The short burning length, together with the previously mentioned possible nonuniform circumferential fuel distribution, caused the maximum combustion efficiency of the can-type combustor configuration to be lower than that of the annular-piloted combustor configuration.

The annular-piloted combustor configuration was designed specifically for the present type of installation and operating conditions as a result of the investigation, reported in reference 9, of a rectangular segment of a similar configuration. This configuration, therefore, was more highly developed for the specific application than were the can-piloted and can-type combustor configurations. In order to permit comparison of the combustion efficiencies of the full-scale annular-piloted combustor configuration and of the rectangular segment of a similar configuration, data from reference 9 are presented in figures 8 and 9 of the present report.

Figure 8, which is based on figure 9 of reference 9, presents the variation of combustion efficiency with fuel-air ratio for a rectangular segment of the annular-piloted combustor configuration developed during the investigation reported therein. Combustion efficiencies of 0.90 or higher were obtained at the design-point fuel-air ratio of 0.035 at combustor-inlet pressures of about 700 to 850 pounds per square foot absolute. These results further indicate the potential combustion efficiency of the full-scale annular-piloted combustor configuration at the design-point conditions. Figure 9, based on figure 8 of reference 9, shows that the configuration evaluated in that investigation

was sensitive to fuel distribution, in that variation in the fuel-injection system changed the fuel-air ratio at which maximum combustion efficiency was obtained; however, such changes did not appreciably affect the maximum combustion-efficiency level.

In the present investigation of the full-scale annular-piloted combustor configuration, only one fuel-injection system was used. The fuel-air ratio (0.025) for maximum combustion efficiency corresponded very closely to that for the configuration of reference 9 (fig. 9) for which fuel was sprayed in the downstream direction. From the results of reference 9, it would appear that optimization of fuel distribution may permit attainment of maximum combustion efficiency at the design-point fuel-air ratio of 0.035. If optimization of the fuel distribution does not prove adequate as a means of permitting maximum combustion efficiency at the desired fuel-air ratio, it is believed that this objective can be accomplished through proper sizing of the annular pilot burner as a flow divider. An effect of flow-divider size, together with the required fuel-distribution modification, on the optimum fuel-air ratio for maximum combustion efficiency may be noted in reference 3.

CONCLUDING REMARKS

Of the three combustor configurations evaluated at an inlet-air temperature of about 990° R in the present investigation, the annular-piloted combustor configuration had the highest combustion efficiency, combustor total-temperature ratio, and net thrust coefficient at the design-point fuel-air ratio of 0.035. The combustor total-pressure ratios of the three configurations were not appreciably different. A maximum combustion efficiency of about 0.90 at a fuel-air ratio of 0.025 was obtained with the annular-piloted configuration at a combustor-inlet total pressure of approximately 1200 pounds per square foot absolute; the combustion efficiency of this configuration was not appreciably affected by reduction in combustor-inlet total pressure to about 800 pounds per square foot absolute. In the annular-piloted combustor configuration, the outer surface of the annular pilot burner provided a protected region for combustion within the surface and served as a flow divider to provide a mainstream combustion region with an approximately stoichiometric fuel-air mixture at low over-all fuel-air ratio. This configuration used sloping radial V-gutter flame holders.

A maximum combustion efficiency of about 0.78 at a fuel-air ratio of 0.035 was obtained with the can-type combustor configuration at a combustor-inlet total pressure of approximately 1200 pounds per square foot absolute. This configuration used a conventional can-type flame holder and also incorporated a flow divider to provide a mainstream

3111

CONFIDENTIAL

combustion region with an approximately stoichiometric fuel-air mixture at low over-all fuel-air ratio. Circumferential distribution of fuel within the flow divider may have been nonuniform for the can-type combustor configuration, and the burning length of this configuration was shorter than that of the other configurations investigated.

A maximum combustion efficiency of about 0.80 was obtained at the highest fuel-air ratio (0.045) investigated with the can-piloted combustor configuration. This configuration used a flame holder consisting of conventional annular V-gutters interconnected with sloping radial V-gutters and included can-type pilot burners to provide combustion stability. In the can-piloted combustor configuration, the radial position of the mainstream fuel-injection system was controlled in an attempt to provide optimum local fuel-air ratios for mainstream combustion at low over-all fuel-air ratio without a mechanical flow divider.

3111

The annular-piloted and can-type combustor configurations, which incorporated mechanical flow dividers for control of the fuel-air mixing process, achieved maximum combustion efficiency at low fuel-air ratio. The combustion efficiency of the can-piloted combustor configuration, which did not incorporate a mechanical flow divider, increased continuously as fuel-air ratio was raised within the range investigated. The results indicate the importance of mechanically confining the mainstream fuel to a portion of the combustor air in order to obtain maximum combustion efficiency at low over-all fuel-air ratio. The design and arrangement of the flame holders and the available burning length also influence the performance differences among the three combustor configurations.

On the basis of the performance capabilities demonstrated in the present preliminary evaluation, the annular-piloted combustor configuration has the greatest promise of permitting combustion efficiencies in excess of 0.90 at low fuel-air ratio with combustor-inlet pressures as low as 700 pounds per square foot absolute. It is believed that, through optimization of fuel distribution or through a combination of sizing the annular pilot burner properly as a flow divider and optimizing of fuel distribution, the desired performance can be obtained with the annular-piloted combustor configuration at the design-point fuel-air ratio.

Lewis Flight Propulsion Laboratory
National Advisory Committee for Aeronautics
Cleveland, Ohio, December 4, 1953

APPENDIX A

SYMBOLS

The following symbols are used in this report:

A	area, sq ft
a	speed of sound, ft/sec
C_A	exhaust-nozzle area coefficient
C_V	exhaust-nozzle velocity coefficient
F_N	net thrust, lb
f/a	fuel-air ratio
g	acceleration due to gravity, 32.2 ft/sec ²
H	enthalpy, Btu/lb of air
h	lower heating value of fuel, Btu/lb
M	Mach number
P	total pressure, lb/sq ft abs
p	static pressure, lb/sq ft abs
q	dynamic pressure, lb/sq ft abs
R	gas constant, 53.4 ft-lb/(lb)(°R)
T	total temperature, °R
V	velocity, ft/sec
W	flow rate, lb/sec
γ	ratio of specific heats
η	combustion efficiency
λ_r	term accounting for the difference between enthalpy of carbon dioxide and water vapor in burned mixture and enthalpy of oxygen removed from air by their formation, Btu/lb

Subscripts:

- a air
- b combustor
- f fuel
- g gas
- w water
- x exit of theoretical diverging exhaust nozzle
- 0 theoretical flight condition
- 2 air-flow measuring station (engine station -28)
- 4 combustion-chamber inlet (48-in. diam.)
- 5 exhaust-nozzle inlet (engine station 83)
- 6 exhaust-nozzle throat (engine station 103)
- 7 exhaust section of test chamber

3111

APPENDIX B

CALCULATIONS

Air flow. - The air flow at station 2 was calculated from pressure and temperature measurements by use of the equation

$$W_a = P_2 A_2 \sqrt{\frac{2\gamma g}{(\gamma-1)RT_2} \left(\frac{P}{p}\right)^{\frac{\gamma-1}{\gamma}} \left[\left(\frac{P}{p}\right)^{\frac{\gamma-1}{\gamma}} - 1 \right]}$$

where $\gamma = 1.4$. Leakage through the engine flanges was approximately accounted for through use of a calibration technique.

Fuel-air ratio. - The fuel-air ratio was calculated directly from the measurement of fuel flow and air flow:

$$f/a = \frac{W_f}{W_a 3600}$$

where W_f was measured in pounds per hour.

Combustor-inlet Mach number. - The combustor-inlet Mach number was computed from the pressure readings at station 2 and the area ratio A_2/A_4 , with isentropic flow between station 2 and 4 assumed.

Combustion-chamber-outlet total temperature. - The combustion-chamber-outlet total temperature was calculated from total-pressure readings at the exhaust-nozzle throat, the gas flow, and the nozzle throat area. It was assumed that the nozzle was choked and that the exhaust-nozzle area coefficient C_A was equal to 0.995. The area blocked by the rake at the nozzle throat was accounted for in A_6 . The expression for T_6 is

$$T_6 = \left(\frac{P_6 A_6 C_A}{W_{g,6}} \right)^2 \frac{g}{R} \frac{\gamma_6}{\left(\frac{\gamma_6+1}{2} \right)^{\frac{\gamma_6+1}{\gamma_6-1}}}$$

In the calculation of T_6 , γ_6 was first assumed, and by trial-and-error method the final value of γ_6 was determined for the final T_6 and the appropriate fuel-air ratio. The gas flow $W_{g,6}$ is the sum of the air flow $W_{a,2}$ and fuel flow W_f .

Combustion efficiency. - Combustion efficiency was defined as

$$\eta = \frac{\text{actual enthalpy rise across the engine}}{\text{heat input}}$$

$$\eta = \frac{(H_{a,6} - H_{a,2}) + \frac{f}{a} \lambda_r + H_w}{\frac{f}{a} h_f}$$

where the first term in the numerator represents the change in enthalpy of the air; and the second term, the difference between the enthalpy rise of the exhaust gases and the enthalpy rise of the air between temperatures T_2 and T_6 . The value of H_w represents the enthalpy rejected to the engine water jackets.

Net thrust coefficient. - The net thrust coefficient used in the present report is defined as $F_N/A_b q_0$. The net thrust F_N was calculated from

$$F_N = C_V \left(\frac{W_{g,6}}{g} V_x \right) + A_x p_x - \frac{W_a}{g} M_0 a_0 \left(\frac{A_x}{\gamma A_0 M_0^2} + 1 \right)$$

and $A_b q_0$ was determined from

$$A_b q_0 = \frac{A_b W_a M_0 a_0}{2g A_0}$$

where C_V was assumed equal to 0.950; A_x , V_x , and p_x are the area, theoretical velocity, and static pressure at the exit of a convergent-divergent exhaust nozzle (which would be used in flight but was not used in this investigation); A_x was assumed equal to A_b , the combustor area; $W_{g,6}$ and W_a are the engine gas and air flows, respectively; M_0 was assumed equal to 2.75; a_0 is the speed of sound at the NACA standard static temperature for altitudes above the tropopause; A_0 is the capture area; and A_b/A_0 was assumed equal to 2.193.

REFERENCES

1. Shillito, T. B., and Nakanishi, Shigeo: Effect of Design Changes and Operating Conditions on Combustion and Operational Performance of a 28-Inch Diameter Ram-Jet Engine. NACA RM E51J24, 1952.
2. Farley, John M., Smith, Robert E., and Povolny, John H.: Preliminary Experiments with Pilot Burners for Ram-Jet Combustors. NACA RM E52J23, 1953.

3. Cervenka, A. J., and Dangle, E. E.: Effect of Fuel-Air Distribution on Performance of a 16-Inch Ram-Jet Engine. NACA RM E52D08, 1952.
4. Dangle, E. E., Cervenka, A. J., and Bahr, D. W.: Effects of Fuel Temperature and Fuel Distribution on the Combustion Efficiency of a 16-Inch Ram-Jet Engine at a Simulated Flight Mach Number of 2.9. NACA RM E52J14, 1953.
5. Trout, Arthur M., and Wentworth, Carl B.: Free-Jet Altitude Investigation of a 20-Inch Ram-Jet Combustor with a Rich Inner Zone of Combustion for Improved Low-Temperature-Ratio Operation. NACA RM E52L26, 1953.
6. Cervenka, A. J., Bahr, D. W., and Dangle, E. E.: Effect of Fuel-Air Ratio Concentration in Combustion Zone on Combustion Performance of a 16-Inch Ram-Jet Engine. NACA RM E53B19, 1953.
7. Cervenka, A. J., Perchonok, Eugene, and Dangle, E. E.: Effect of Fuel Injector Location and Mixture Control on Performance of a 16-Inch Ram-Jet Can-Type Combustor. NACA RM E53F15, 1953.
8. Henzel, James G., Jr., and Wentworth, Carl B.: Free-Jet Investigation of 20-Inch Ram-Jet Combustor Utilizing High-Heat-Release Pilot Burner. NACA RM E53H14, 1953.
9. Rayle, Warren, D., and Koch, Richard G.: Design of Combustor for Long-Range Ram-Jet Engine and Performance of Rectangular Analog. NACA RM E53K13, 1954.

T112

CU-3 back

CONFIDENTIAL

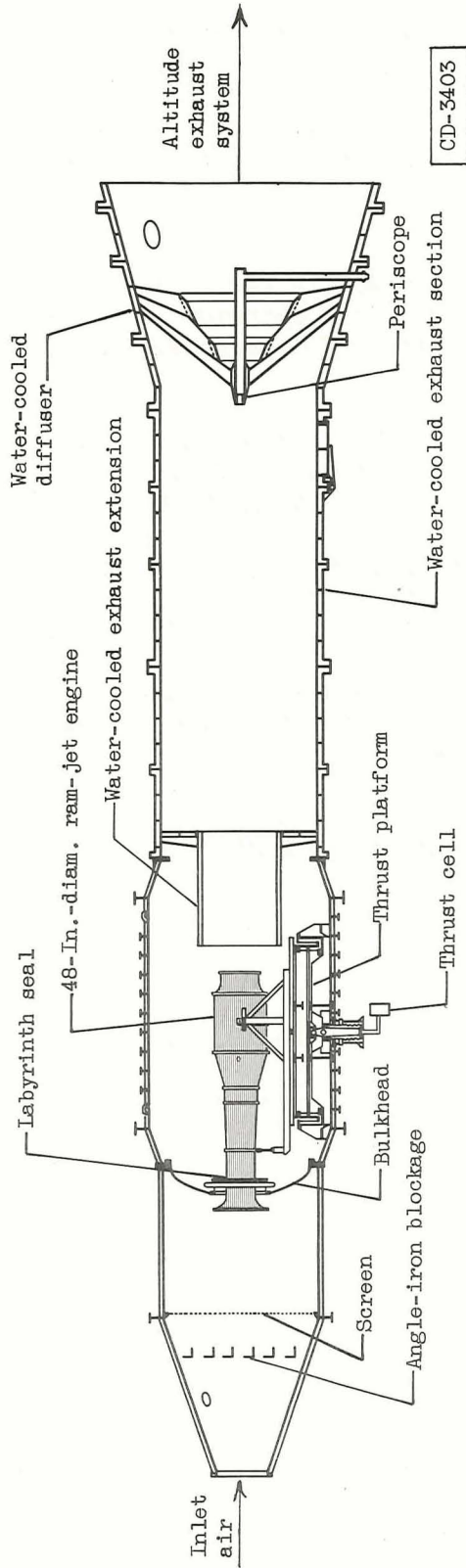
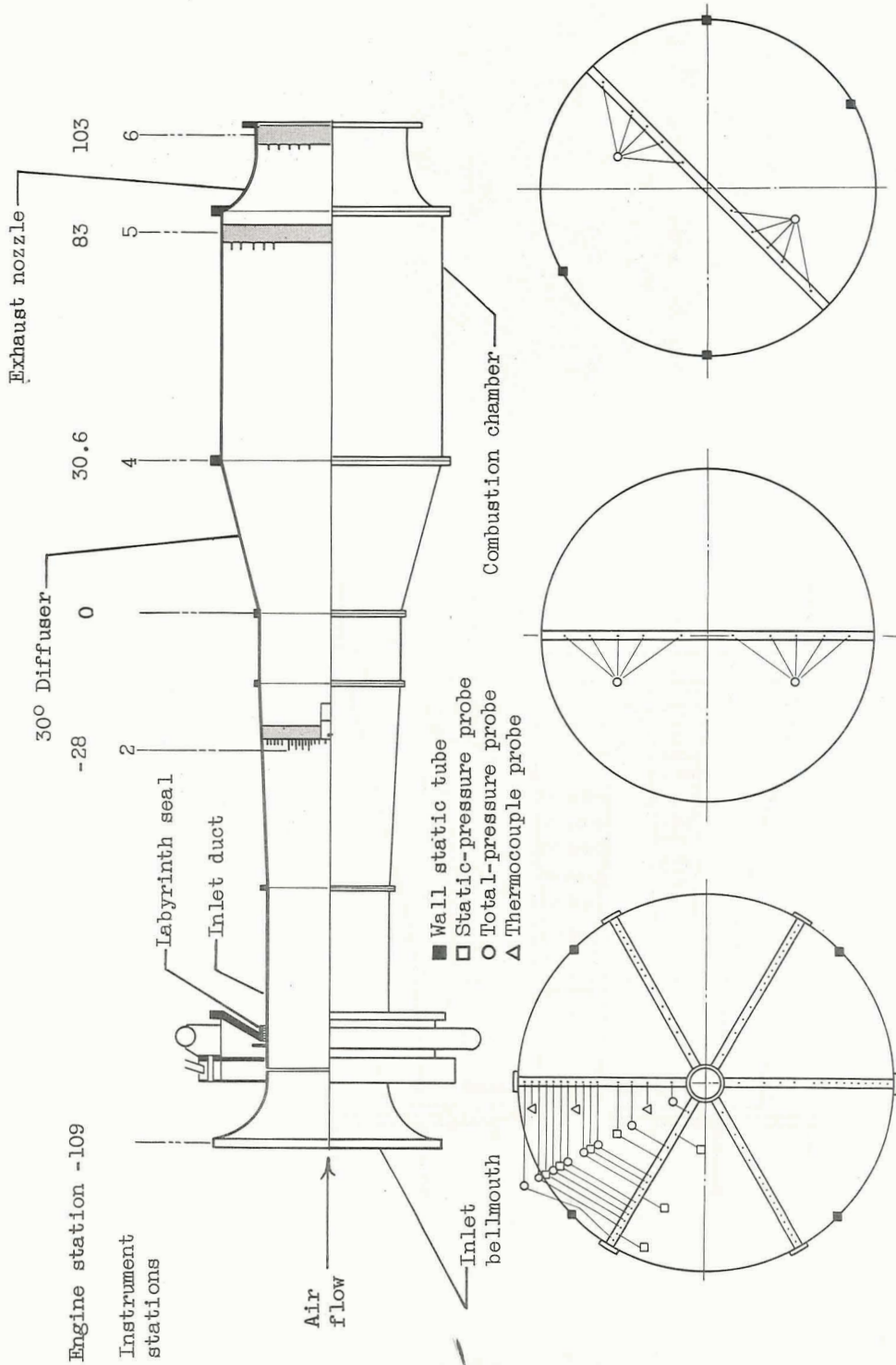

Figure 1. - Schematic diagram of installation of 48-inch-diameter ram-jet engine in 14-foot-diameter altitude chamber.

CONFIDENTIAL

3111



CD-3402

Figure 2. - Schematic diagram of 48-inch-diameter ram-jet engine showing instrumentation and station locations.

CONFIDENTIAL

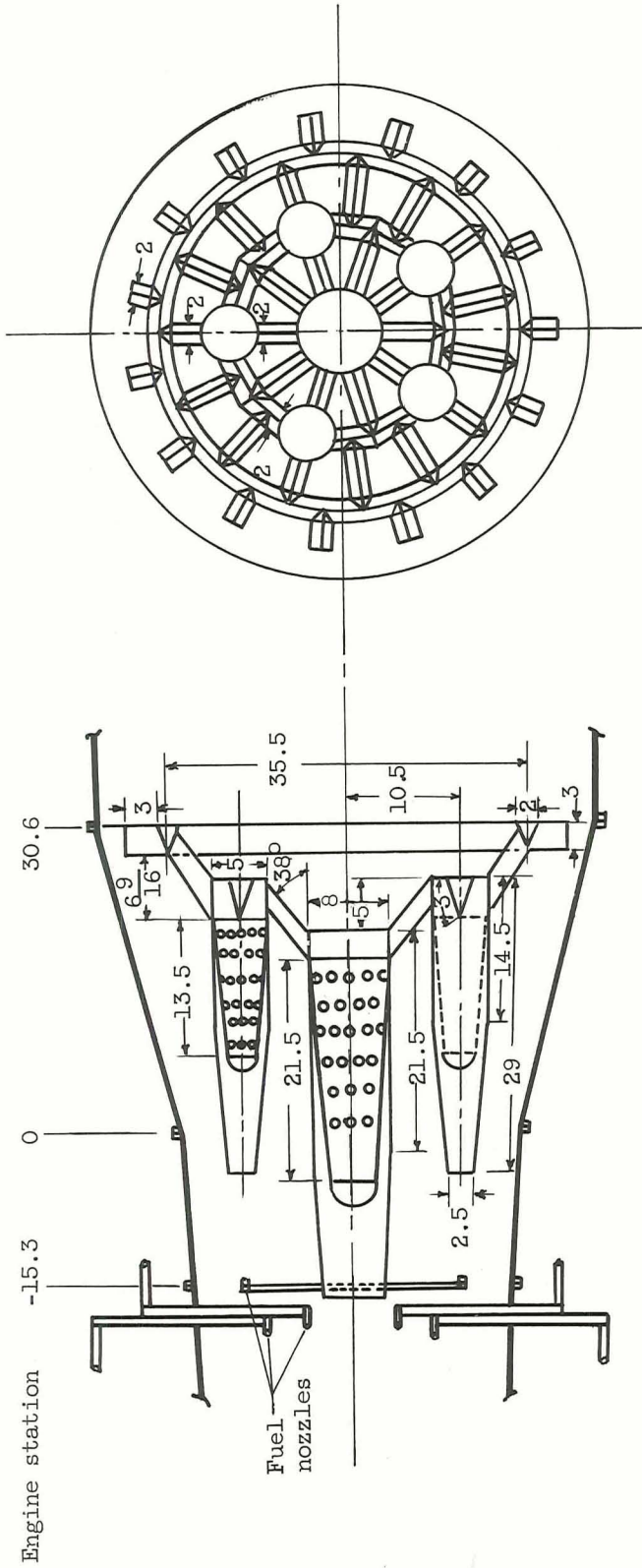

(a) Schematic diagram. (All dimensions in inches.)

Figure 3. - Can-piloted combustor configuration.

CONFIDENTIAL

3111

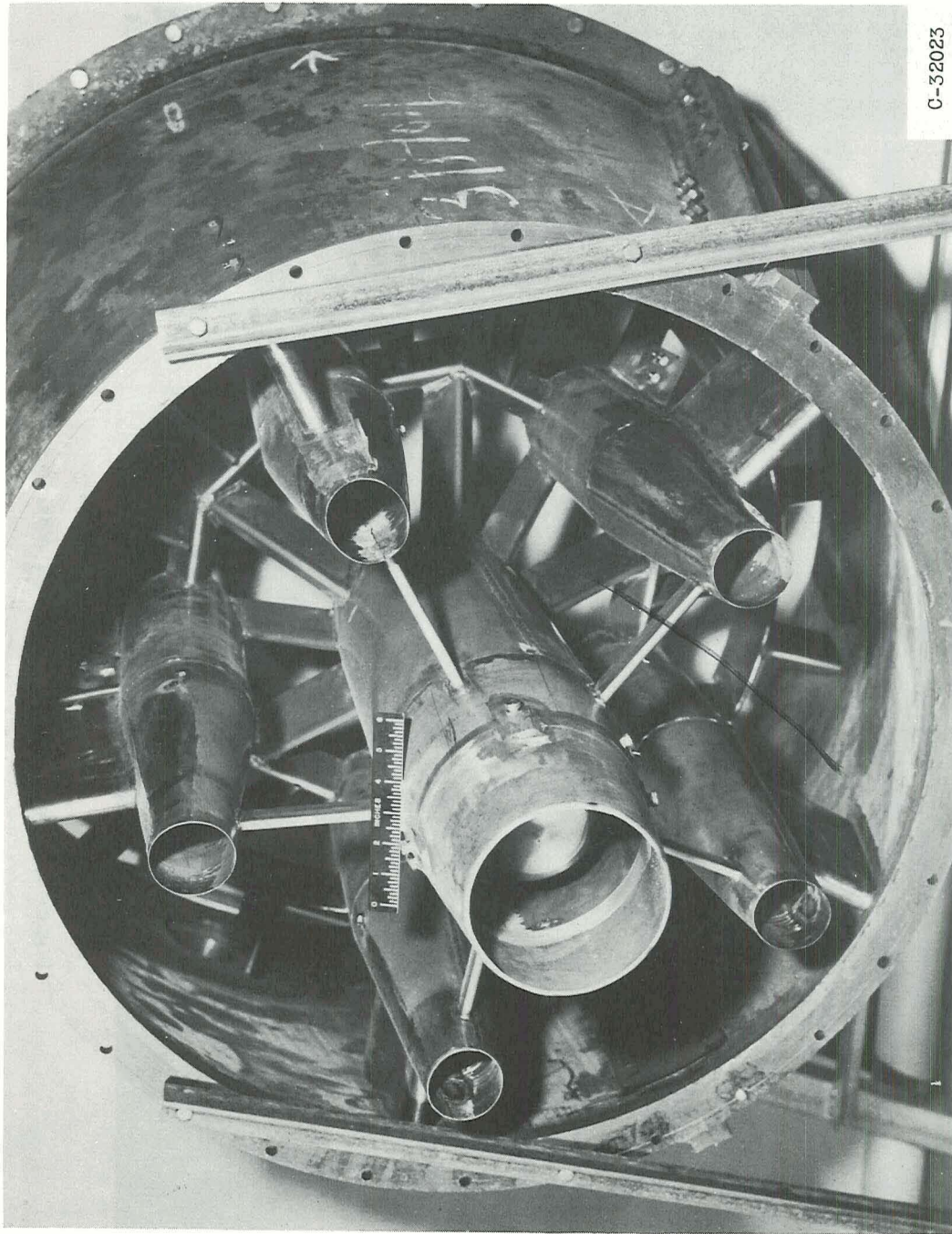

C-32023

(b) View from upstream.

Figure 3. - Continued. Can-piloted combustor configuration.

~~CONFIDENTIAL~~

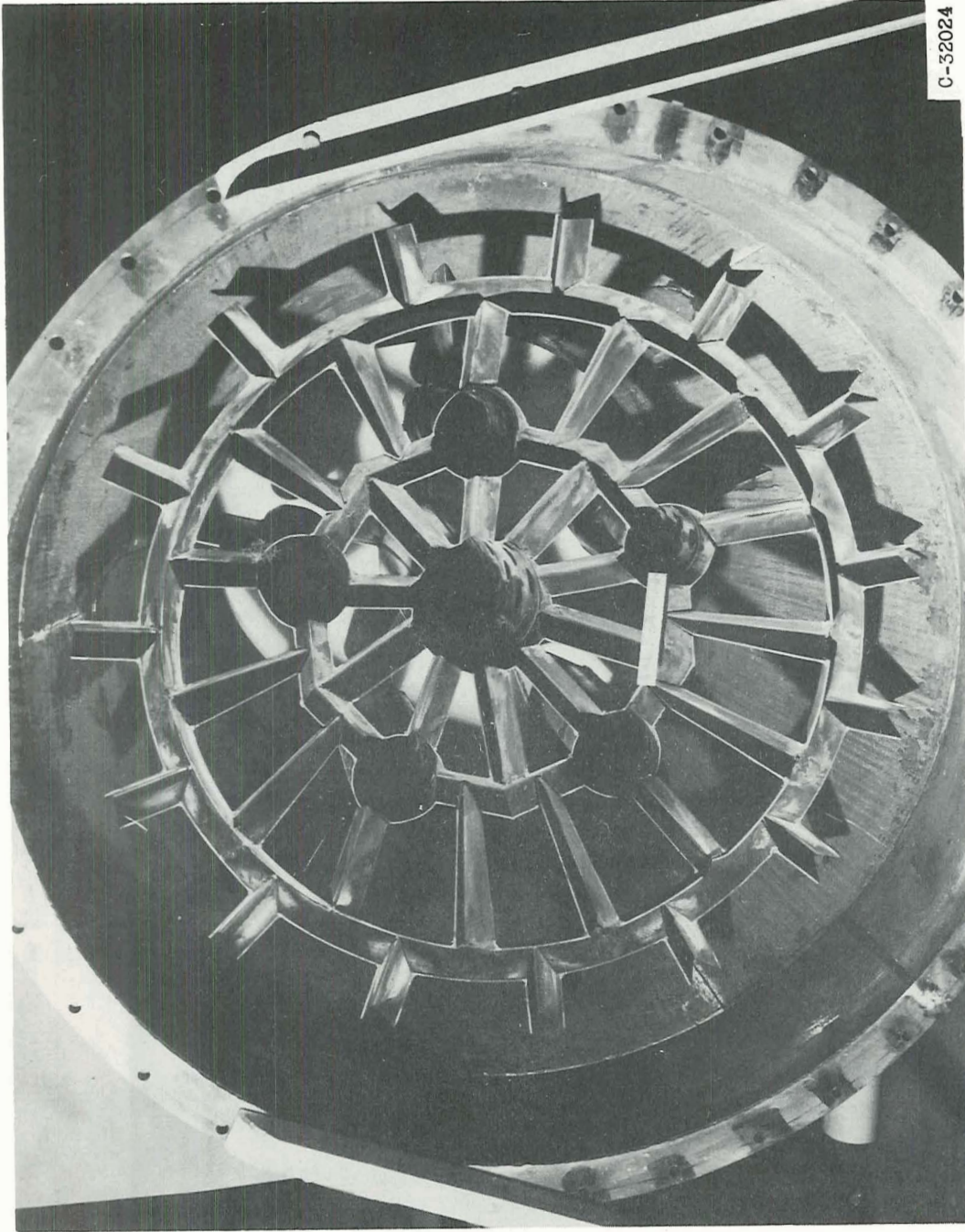

C-32024

(c) View from downstream.

Figure 3. - Continued. Can-piloted combustor configuration.

3111

~~CONFIDENTIAL~~

3111

CU-4

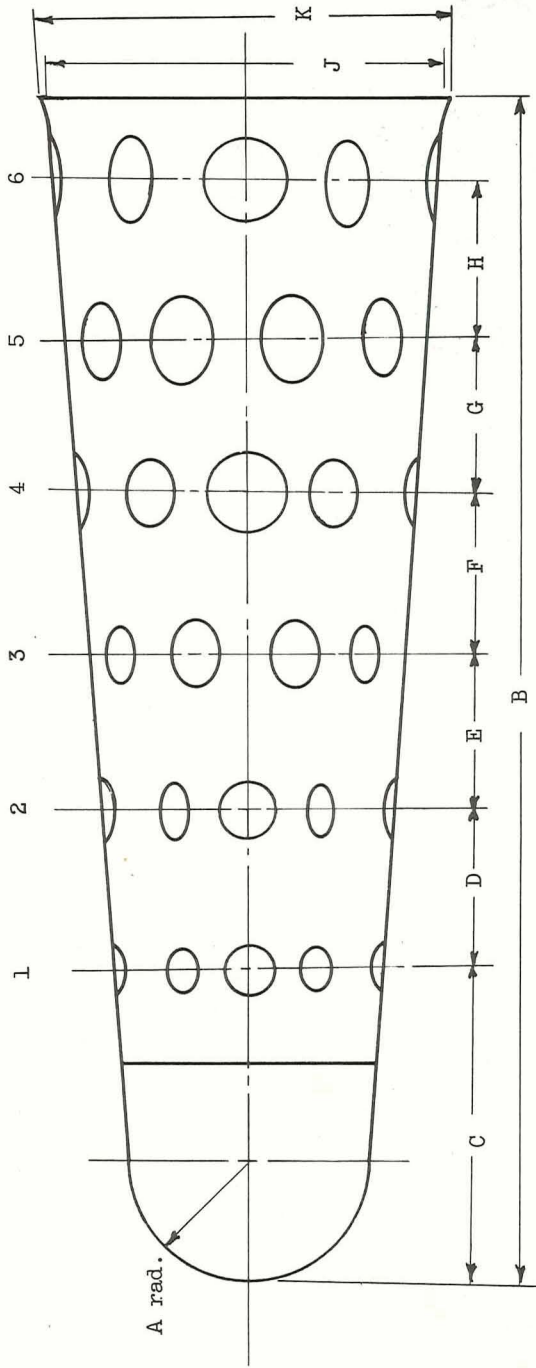

Pilots	Distance, in.										
	A	B	C	D	E	F	G	H	J	K	
Outer	$1\frac{1}{2}$	15	4	2	2	2	2	2	4.8	5	
Center	$2\frac{3}{8}$	24	$6\frac{3}{8}$	3.2	3.2	3.2	3.2	3.2	7.8	8	

All pilots	Row					
	1	2	3	4	5	6
Number of holes	9	8	8	8	8	8
Outer-pilot hole diam., in.	$1\frac{1}{2}$	$\frac{5}{8}$	$\frac{3}{4}$	$\frac{7}{8}$	$\frac{15}{16}$	1
Center-pilot hole diam., in.	$2\frac{3}{8}$	$\frac{13}{16}$	1	$\frac{3}{16}$	$\frac{1}{2}$	$\frac{5}{8}$

(d) Details of cans used.

Figure 3. - Concluded. Can-piloted combustor configuration.

CONFIDENTIAL

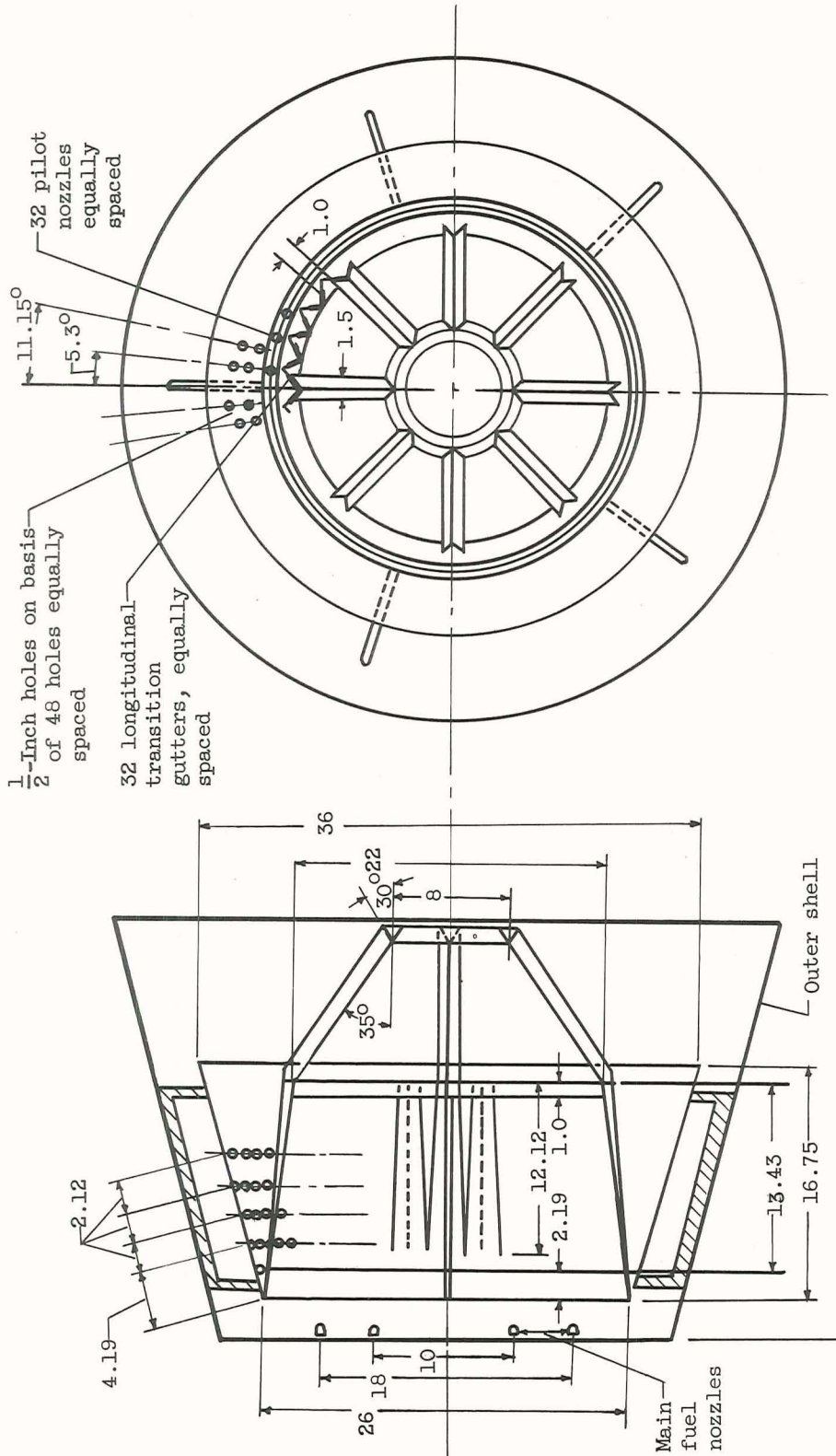

(a) Schematic diagram. (All dimensions in inches.)

Figure 4. - Annular-piloted combustor configuration.

CONFIDENTIAL

3111

CU-4 back

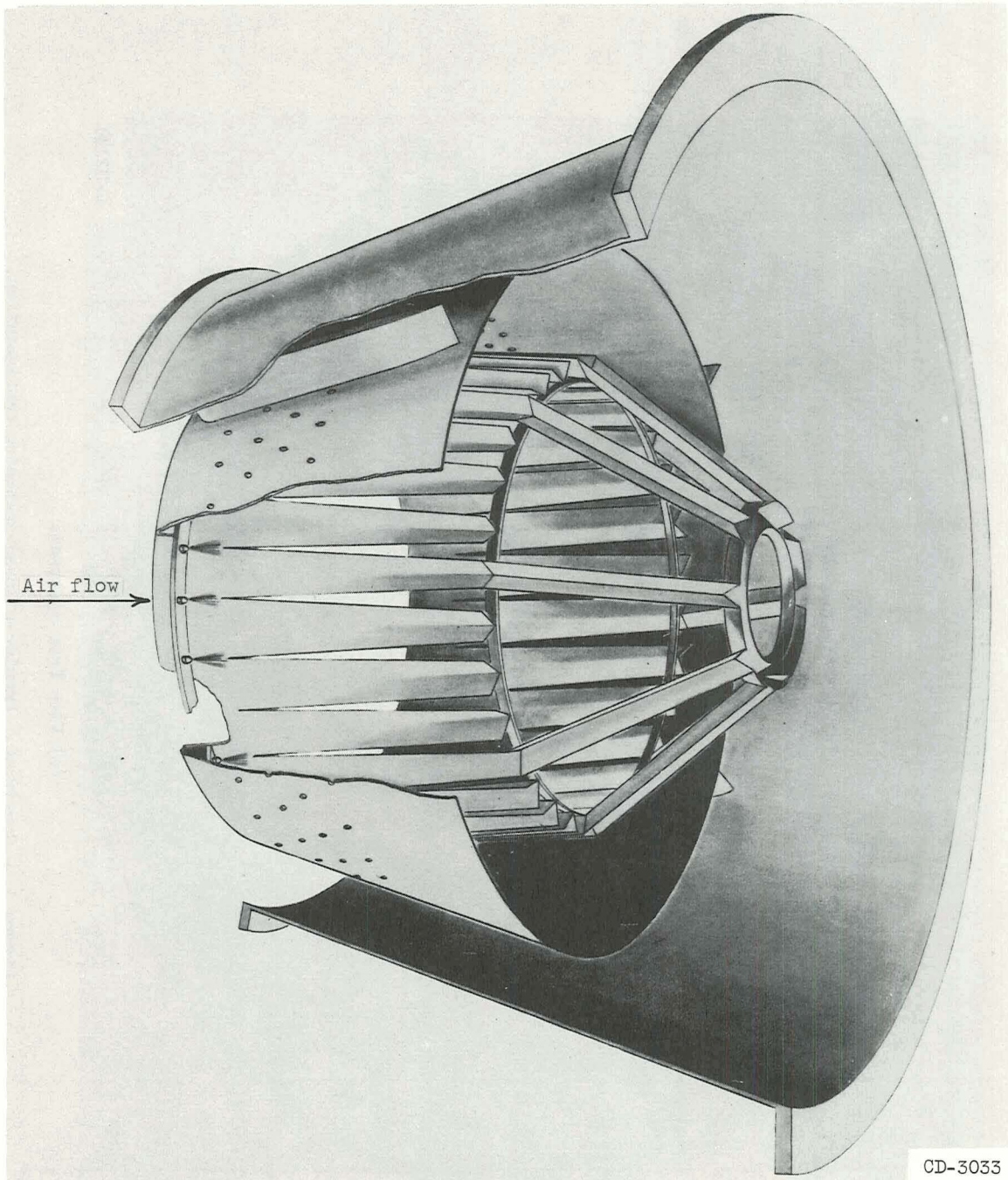

CD-3033

(b) Cutaway view.

Figure 4. - Continued. Annular-piloted combustor configuration.

~~CONFIDENTIAL~~

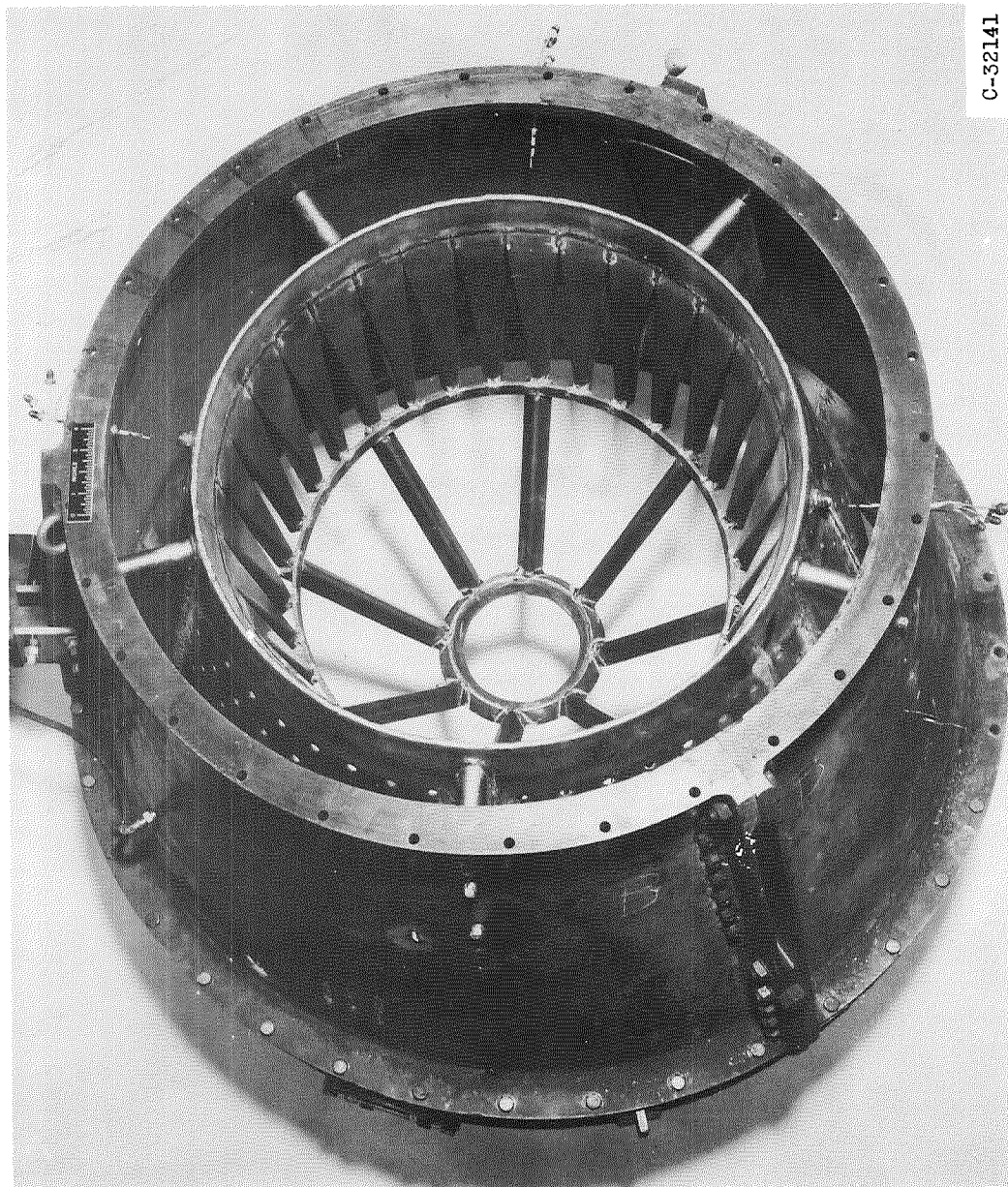

C-32141

(c) View from upstream.

Figure 4. - Continued. Annular-piloted combustor configuration.

~~CONFIDENTIAL~~

~~CONFIDENTIAL~~

3111

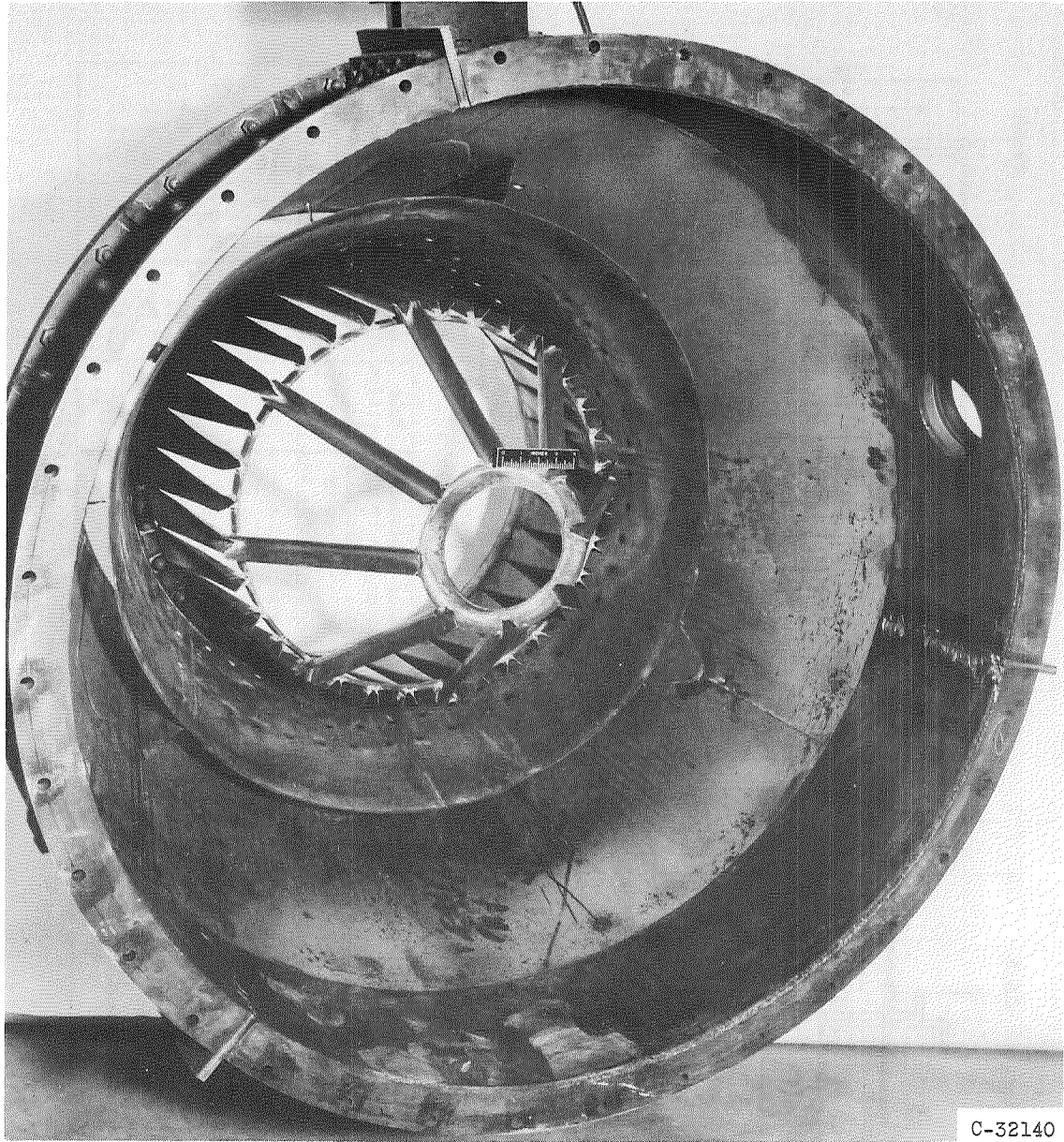

C-32140

(d) View from downstream.

Figure 4. - Concluded. Annular-piloted combustor configuration.

~~CONFIDENTIAL~~

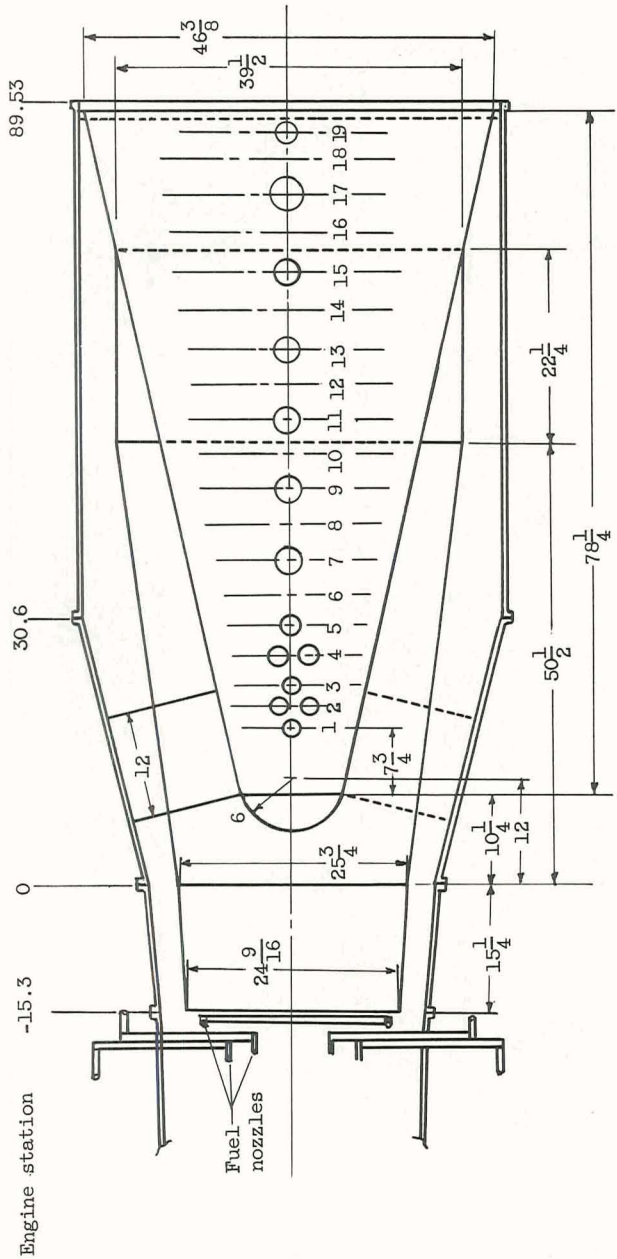

Hole position	Number of holes equally spaced	Hole diam., in.	Distance from previous row of holes, in.	Hole position	Number of holes equally spaced	Hole diam., in.	Distance from previous row of holes, in.	Hole position	Number of holes equally spaced	Hole diam., in.	Distance from previous row of holes, in.
1	12	1.5	---	7	24	2.5	4.0	14	24	3.0	4.5
2	12	1.5	2.5	8	24	2.5	4.0	15	24	3.0	4.5
3	24	1.5	2.5	9	24	2.5	4.0	16	24	3.0	4.5
4	24	2.0	3.5	10	24	2.5	4.0	17	24	3.0	4.5
5	24	2.0	3.5	11	24	2.5	4.0	18	24	3.0	4.0
6	24	2.0	3.5	12	24	2.5	4.0	19	48	1.5	3.0
				13	24	2.5	4.0				

(a) Schematic diagram. (All dimensions in inches.)

Figure 5. - Can-type combustor configuration.

3111

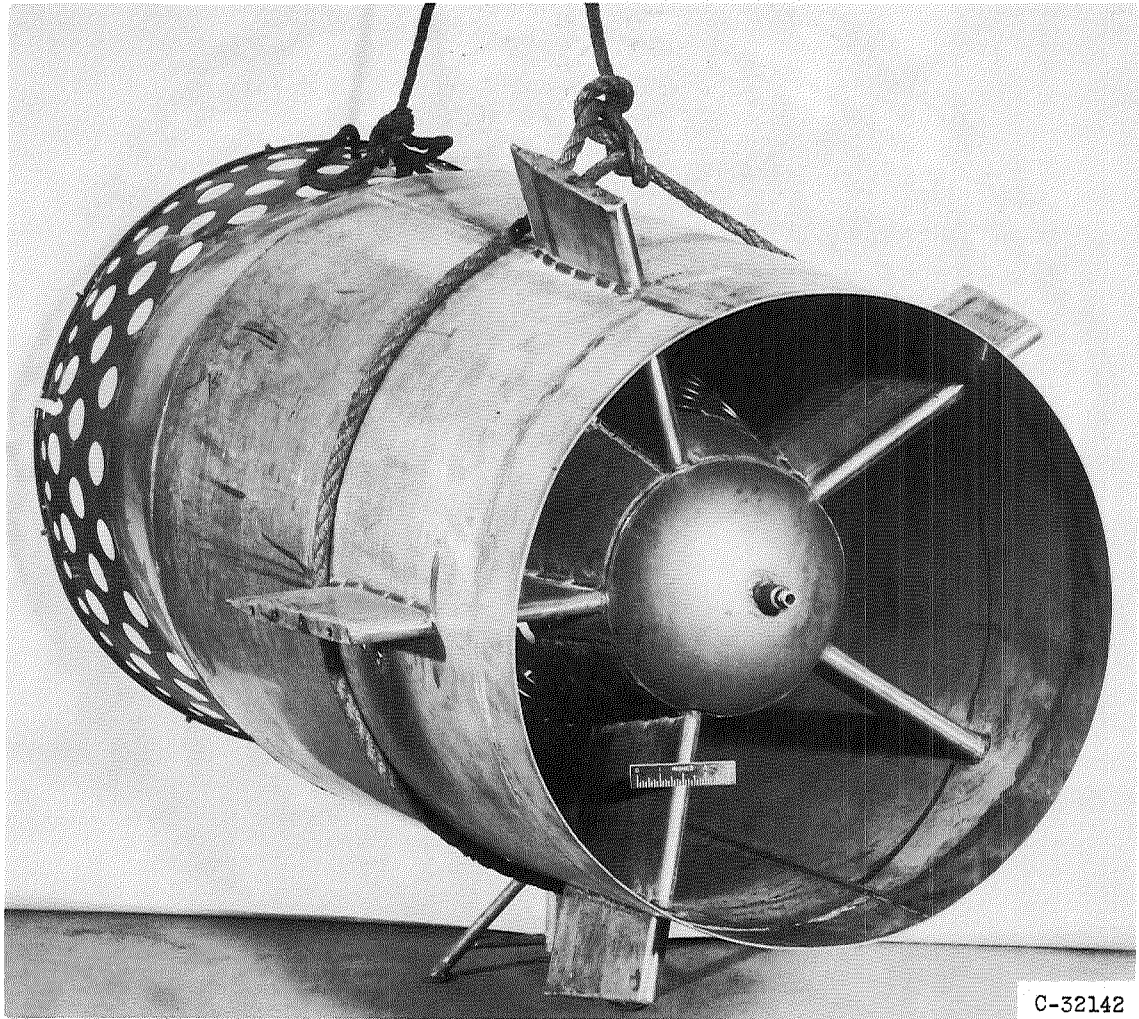

(b) View from upstream.

Figure 5. - Continued. Can-type combustor configuration.

~~CONFIDENTIAL~~

3111

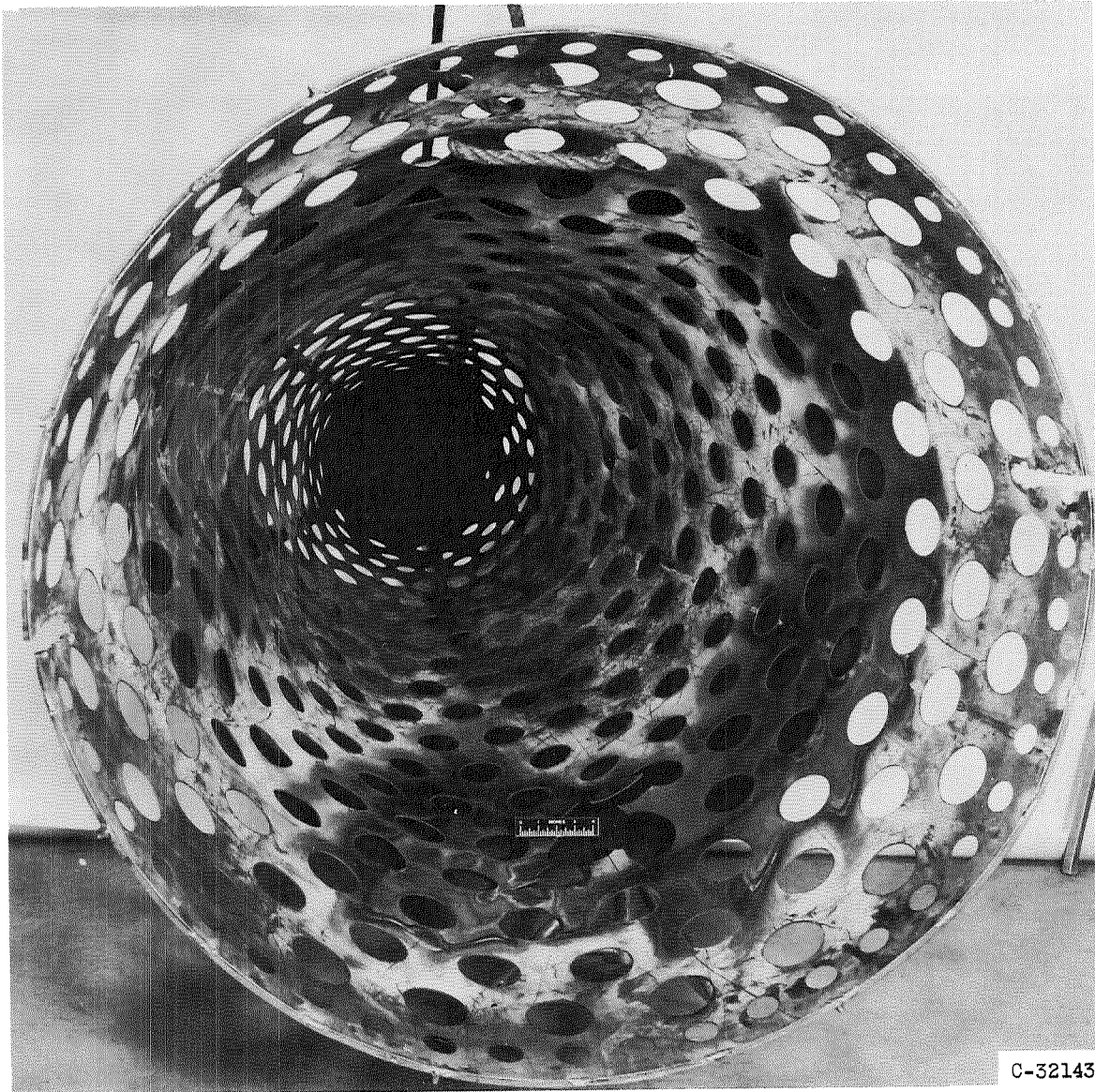

(c) View from downstream.

Figure 5. - Concluded. Can-type combustor configuration.

~~CONFIDENTIAL~~

~~CONFIDENTIAL~~

3111

CU-5

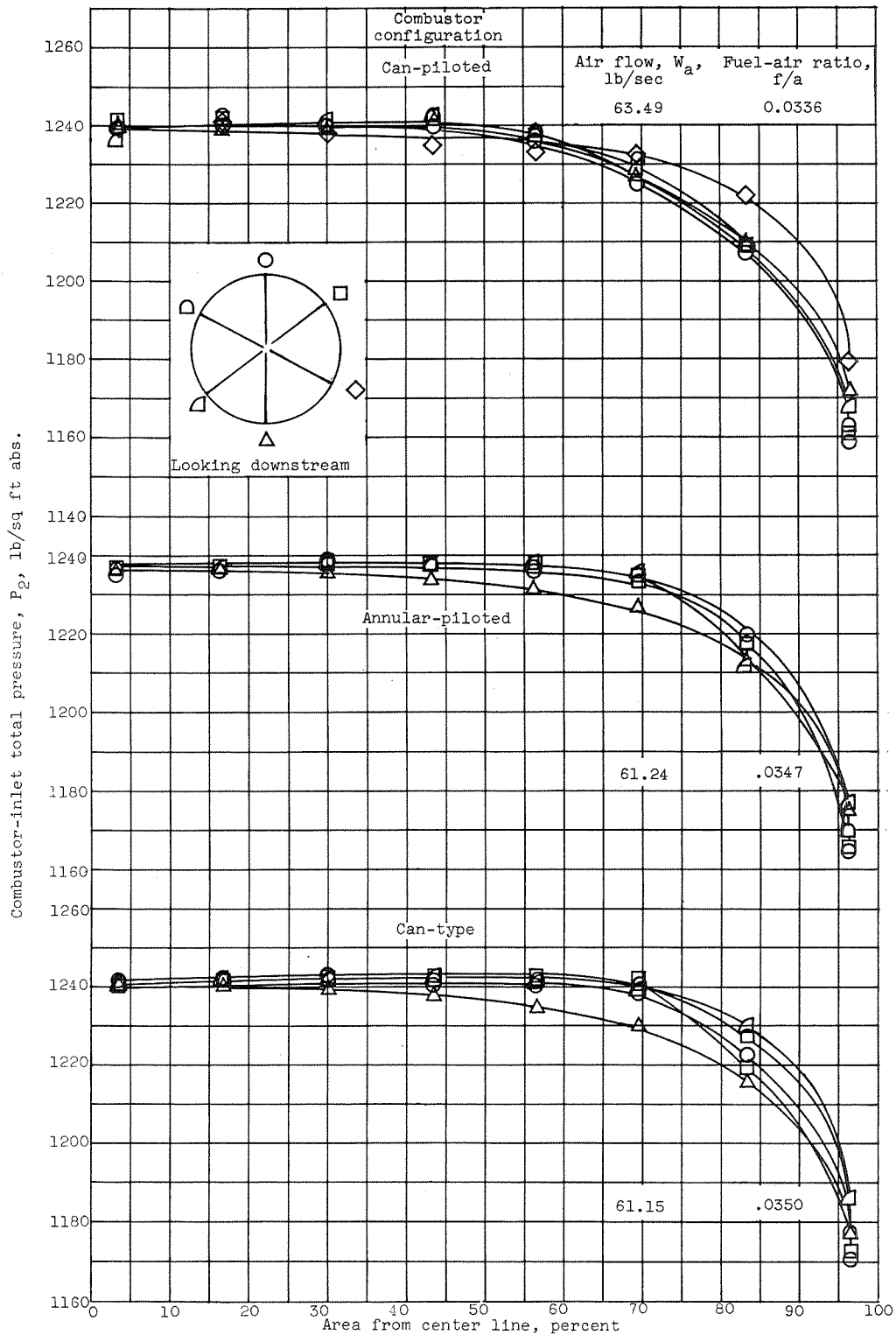

(a) Radial total-pressure distribution.
 Figure 6. - Combustor-inlet conditions for three low-temperature-ratio combustor configurations. Inlet-air temperature, 990° R.

~~CONFIDENTIAL~~

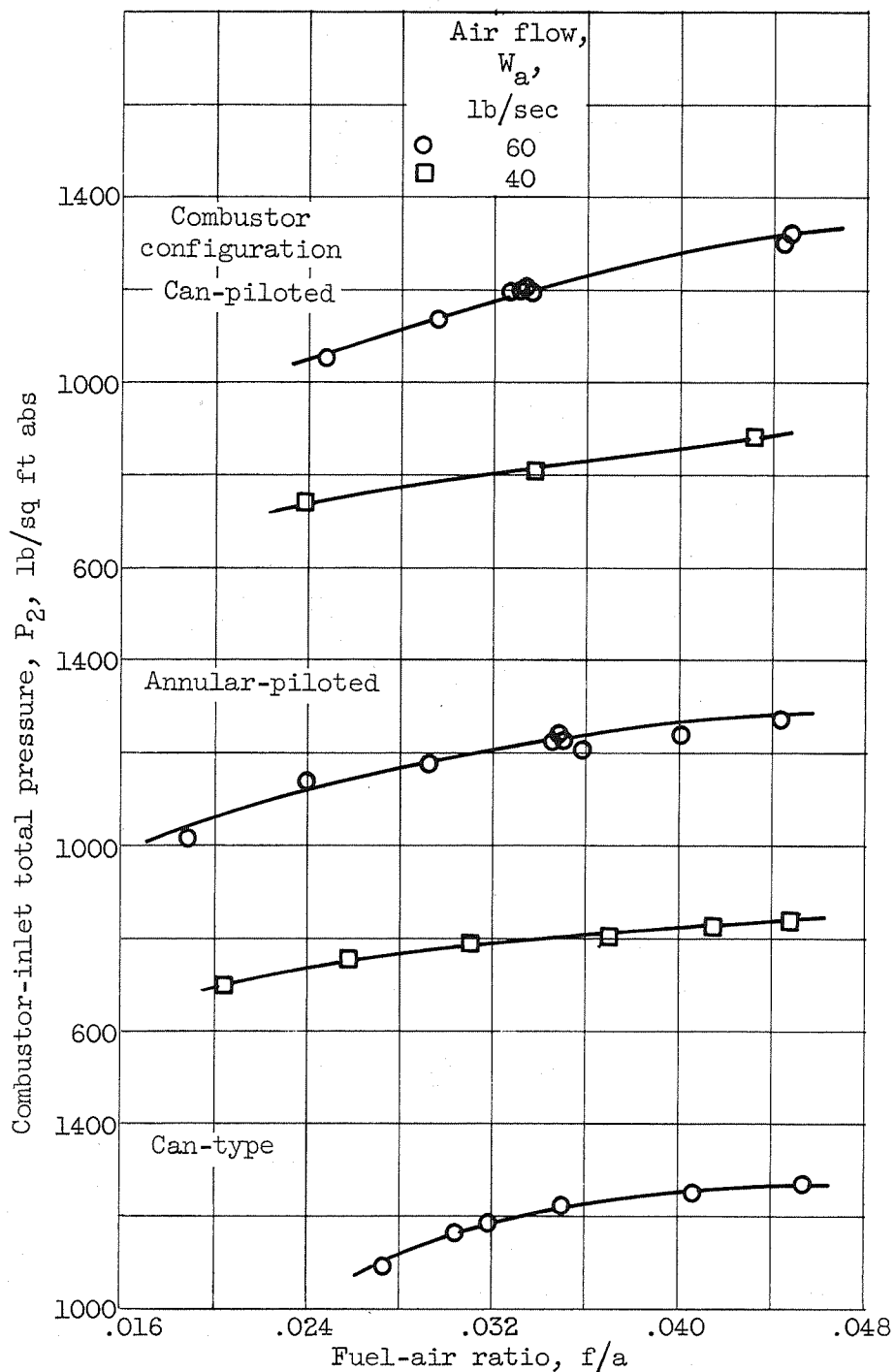

(b) Total-pressure variation.

Figure 6. - Continued. Combustor-inlet conditions for three low-temperature-ratio combustor configurations. Inlet-air temperature, 990°R .

3111

CU-5 back

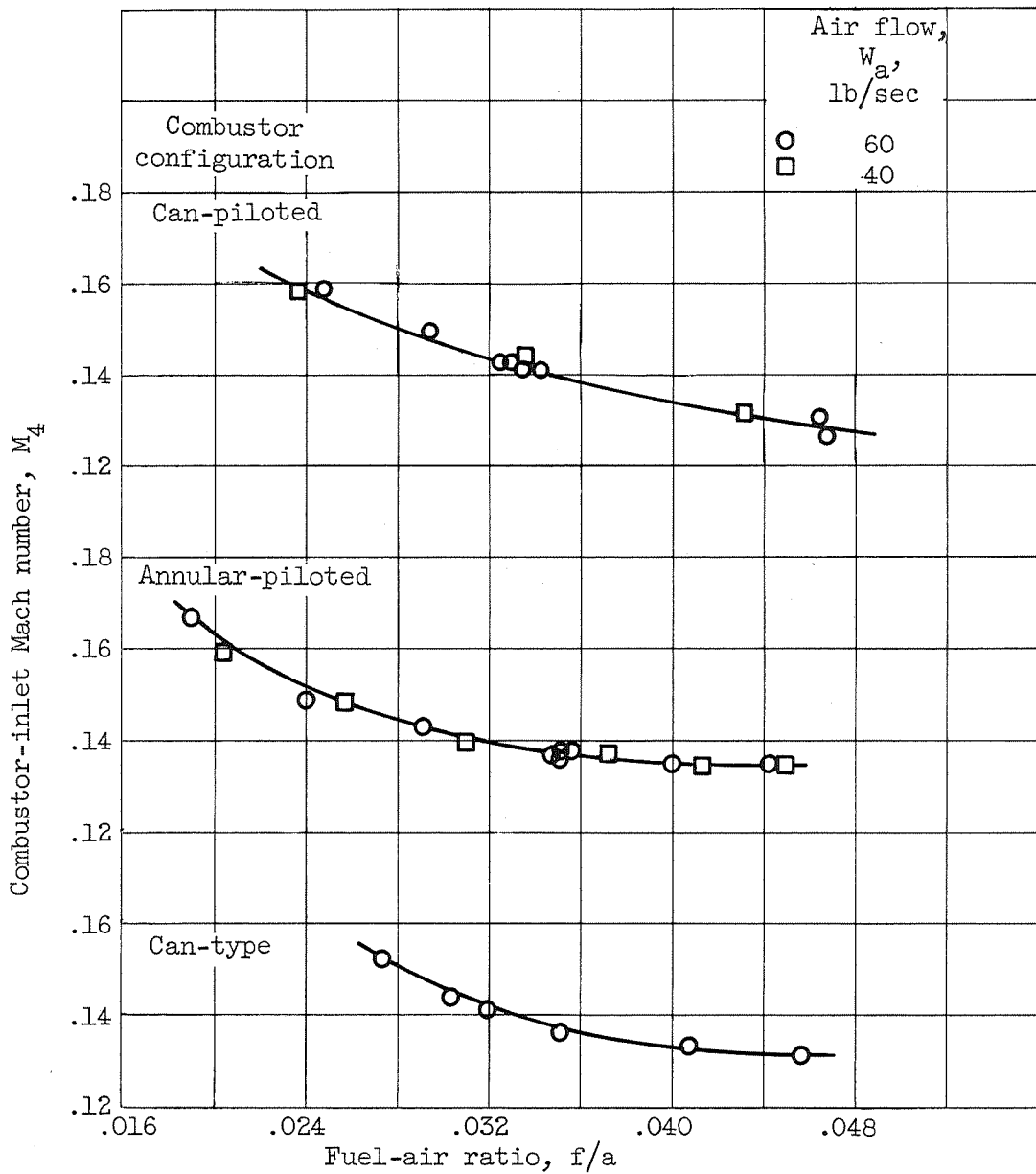

(c) Mach number variation.

Figure 6. - Concluded. Combustor-inlet conditions for three low-temperature-ratio combustor configurations. Inlet-air temperature, 990° R.

CONFIDENTIAL

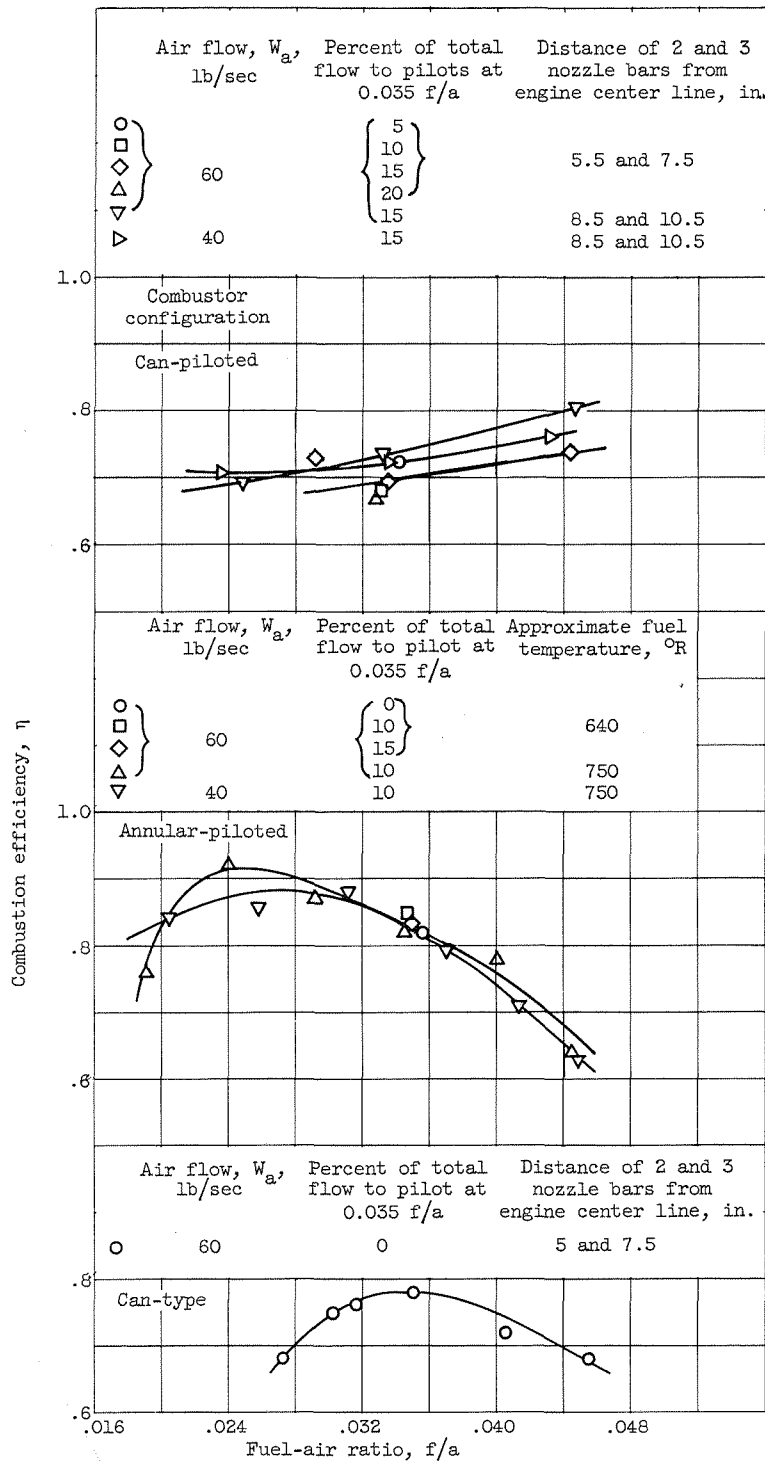

(a) Combustion efficiency. Approximate fuel temperature for can-piloted and can-type combustors, 640° R.

Figure 7.-- Performance of three low-temperature-ratio combustor configurations. Inlet-air temperature, 990° R.

3111

~~CONFIDENTIAL~~

3111

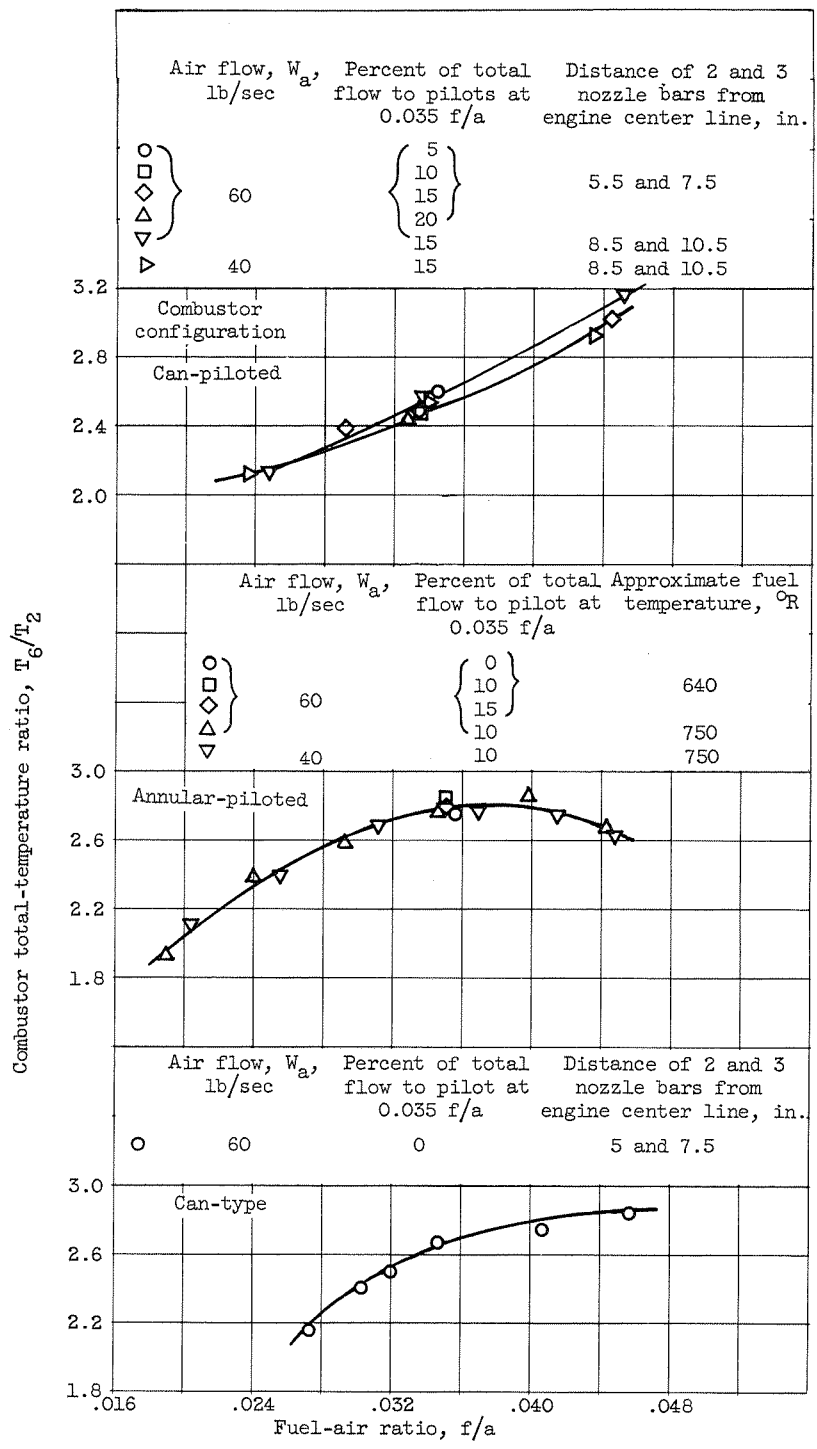

(b) Total-temperature ratio. Approximate fuel temperature for can-piloted and can-type combustors, 640° R.

Figure 7. - Continued. Performance of three low-temperature-ratio combustor configurations. Inlet-air temperature, 990° R.

~~CONFIDENTIAL~~

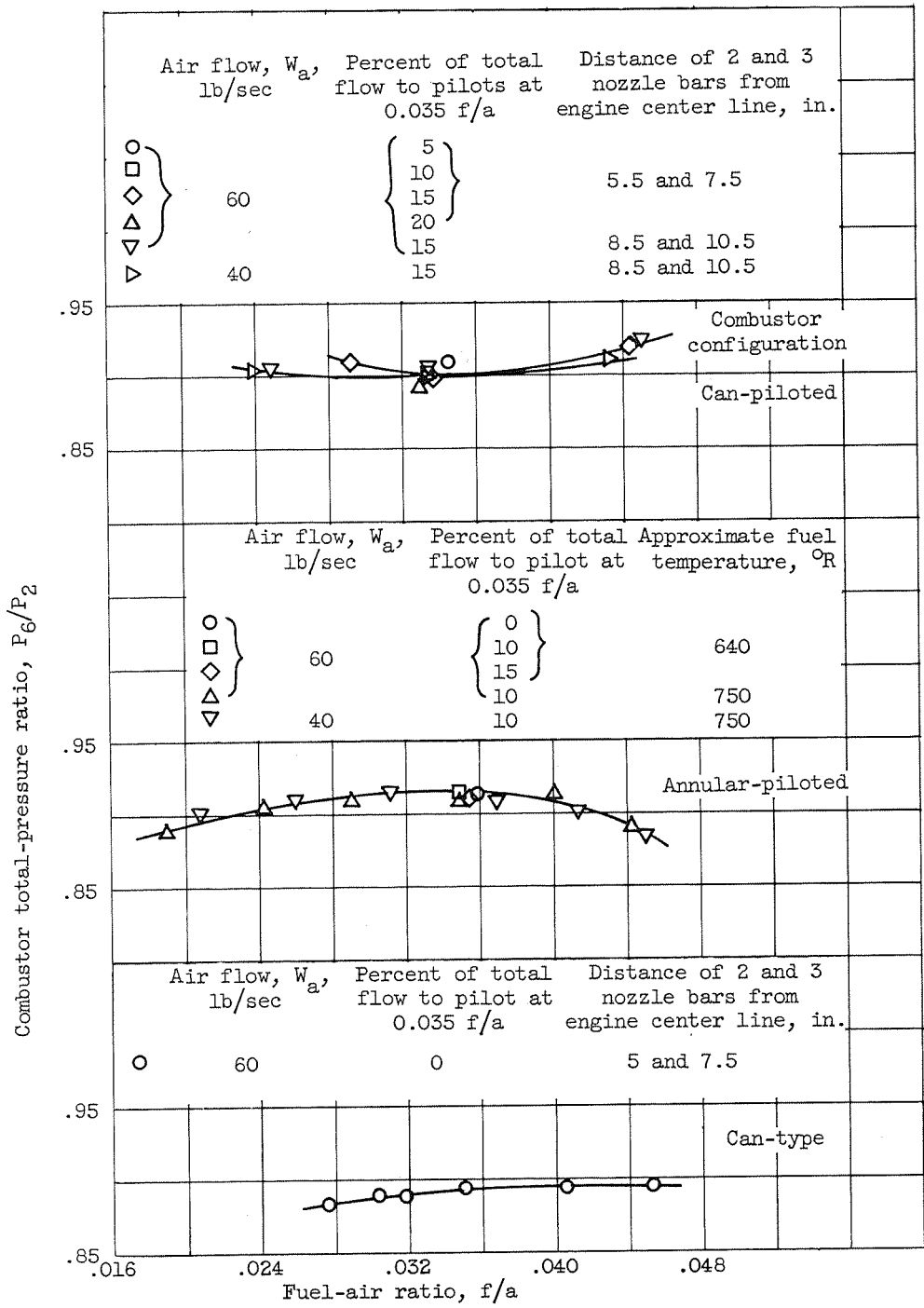

(c) Total-pressure ratio. Approximate fuel temperature for can-piloted and can-type combustors, 640° R.

Figure 7. - Continued. Performance of three low-temperature-ratio combustor configurations. Inlet-air temperature, 990° R.

CONFIDENTIAL

5111

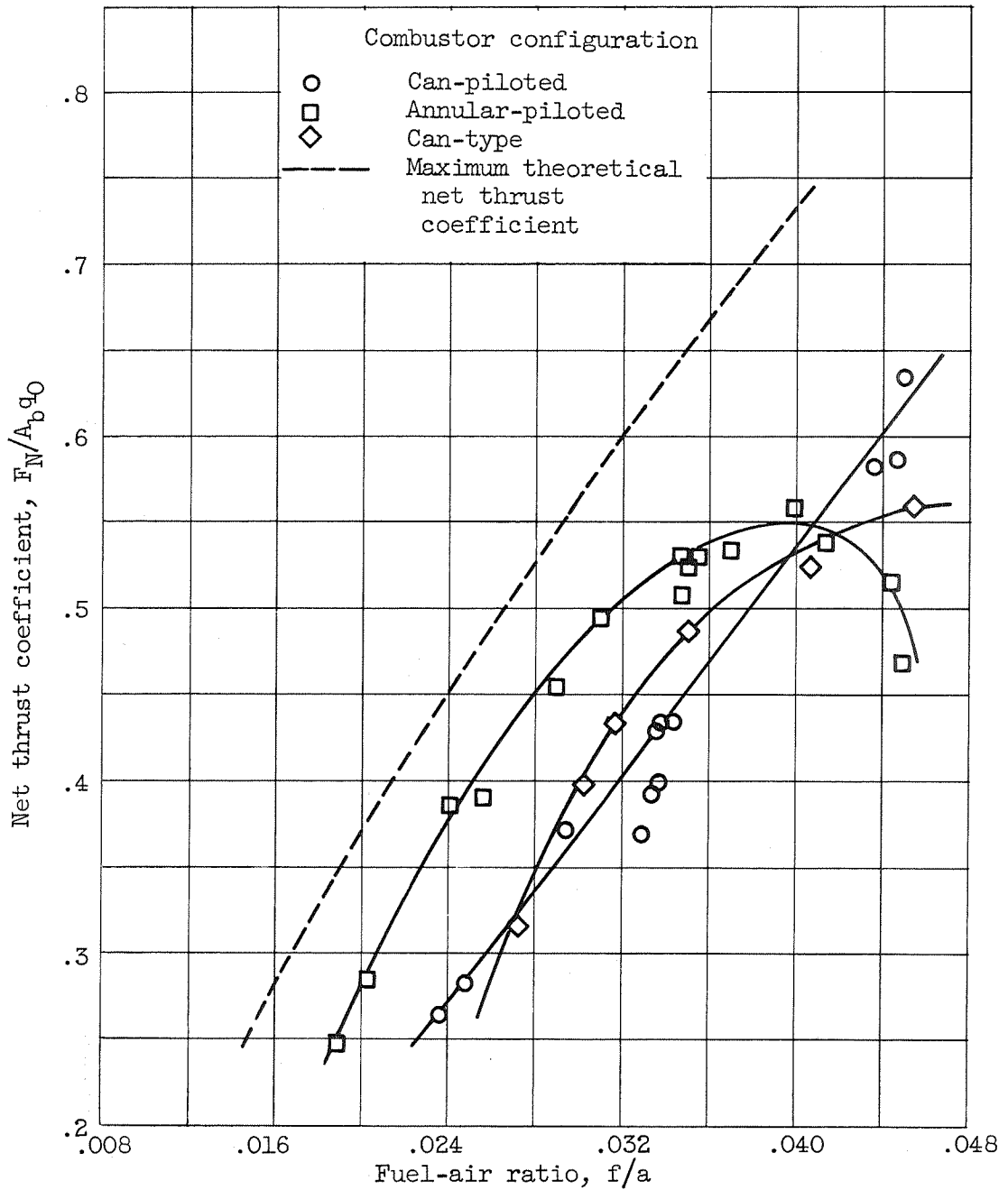

(d) Net thrust coefficient.

Figure 7. - Concluded. Performance of three low-temperature-ratio combustor configurations. Inlet-air temperature, 990° R.

CONFIDENTIAL

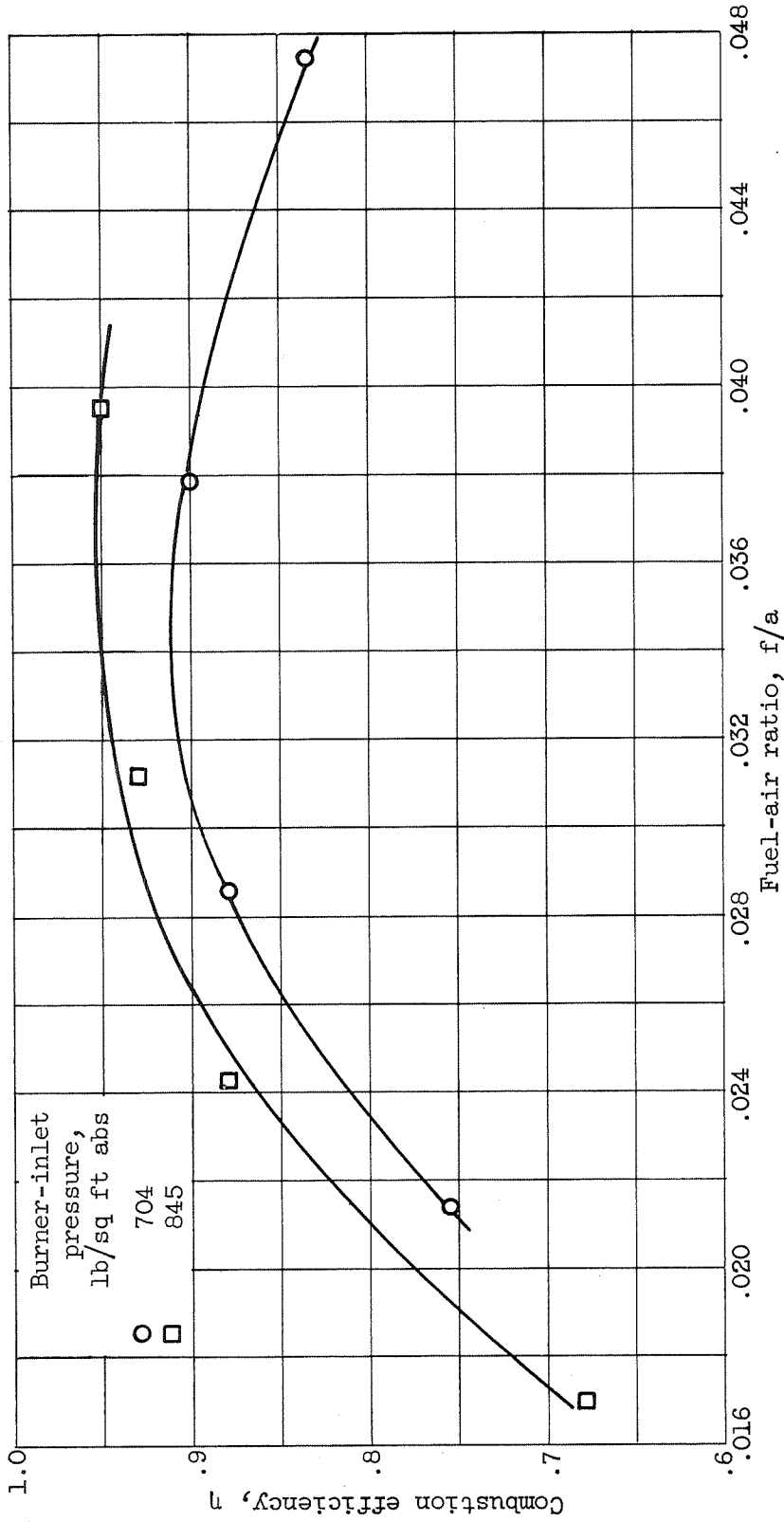

Figure 8. - Variation of combustion efficiency with fuel-air ratio at two burner-inlet pressures for rectangular segment of annular-piloted combustor configuration. Burner-inlet temperature, 530° F; burner-inlet Mach number, 0.150. (Based on fig. 9 of ref. 9.)

~~CONFIDENTIAL~~

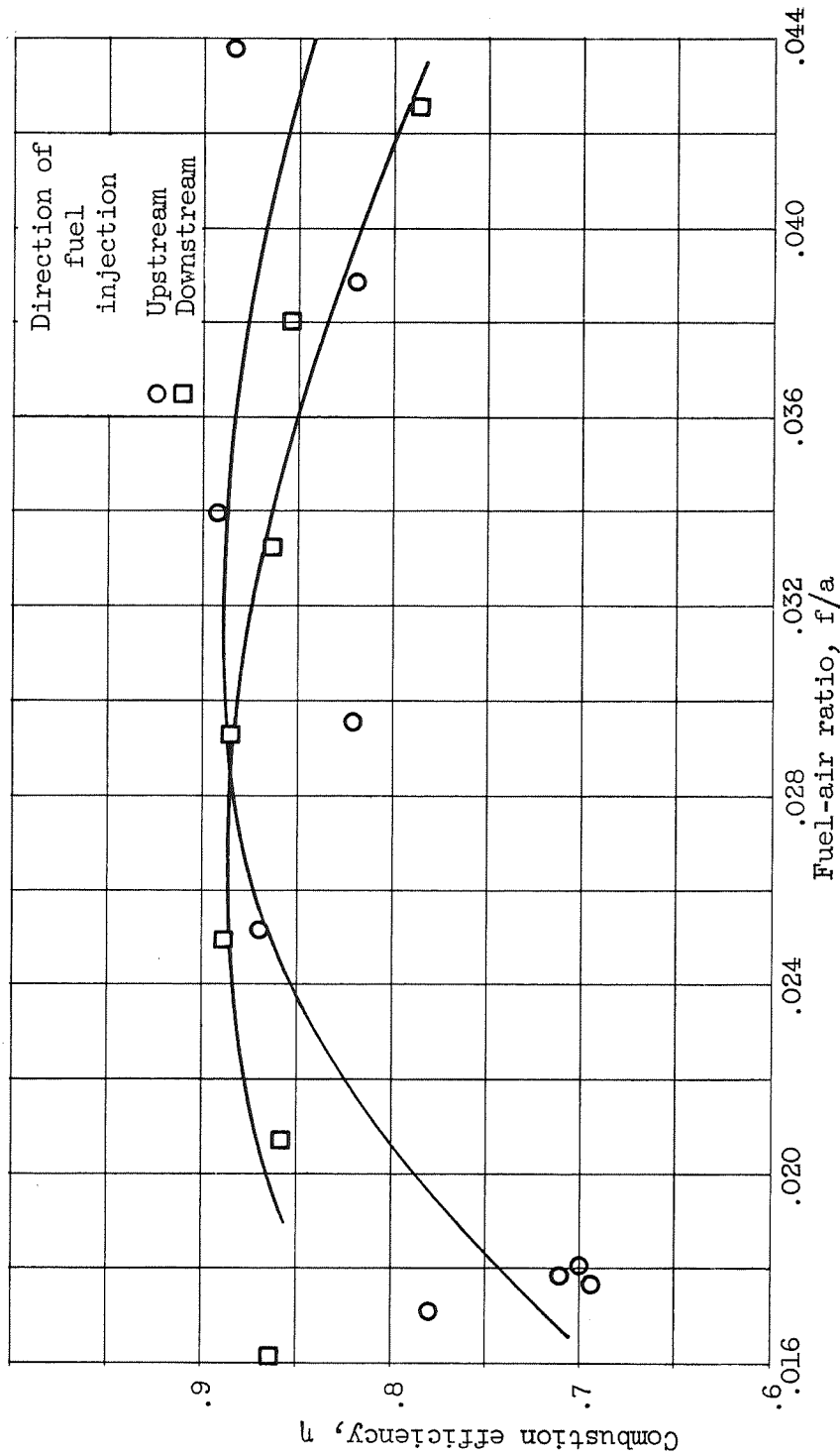

Figure 9. - Effect of method of fuel injection on variation of combustion efficiency with fuel-air ratio for rectangular segment of annular-piloted combustor configuration. Burner-inlet pressure, 704 pounds per square foot absolute; burner-inlet temperature, 530° F; burner-inlet Mach number, 0.150. (Based on fig. 8 of ref. 9.)

~~CONFIDENTIAL~~

CONFIDENTIAL

CONFIDENTIAL